

# **Frequency-Agile LIDAR Receiver for Chemical and Biological Agent Sensing**

**Bogdan R. Cosofret, Ian M. Konen, and Ankit H. Patel**

**Physical Sciences Inc., 20 New England Business Center, Andover MA 01810**

**Patrick Cobler**

**VTech Engineering Corporation**

**Raphael P. Moon**

**U.S. Army Edgewood Chemical Biological Center, RDCB-DRD-L, E5560,  
Aberdeen Proving Grounds, MD 21010**

**Jeffrey L. Ahl**

**JLA Technology Corporation, 371 O St. SW, Washington, DC 20024**

# Report Documentation Page

Form Approved  
OMB No. 0704-0188

Public reporting burden for the collection of information is estimated to average 1 hour per response, including the time for reviewing instructions, searching existing data sources, gathering and maintaining the data needed, and completing and reviewing the collection of information. Send comments regarding this burden estimate or any other aspect of this collection of information, including suggestions for reducing this burden, to Washington Headquarters Services, Directorate for Information Operations and Reports, 1215 Jefferson Davis Highway, Suite 1204, Arlington VA 22202-4302. Respondents should be aware that notwithstanding any other provision of law, no person shall be subject to a penalty for failing to comply with a collection of information if it does not display a currently valid OMB control number.

1. REPORT DATE <b>JUN 2010</b>		2. REPORT TYPE		3. DATES COVERED <b>00-00-2010 to 00-00-2010</b>	
4. TITLE AND SUBTITLE <b>Frequency-Agile LIDAR Receiver for Chemical and Biological Agent Sensing</b>				5a. CONTRACT NUMBER	
				5b. GRANT NUMBER	
				5c. PROGRAM ELEMENT NUMBER	
6. AUTHOR(S)				5d. PROJECT NUMBER	
				5e. TASK NUMBER	
				5f. WORK UNIT NUMBER	
7. PERFORMING ORGANIZATION NAME(S) AND ADDRESS(ES) <b>Physical Sciences Inc,20 New England Business Center,Andover,MA,01810</b>				8. PERFORMING ORGANIZATION REPORT NUMBER	
9. SPONSORING/MONITORING AGENCY NAME(S) AND ADDRESS(ES)				10. SPONSOR/MONITOR'S ACRONYM(S)	
				11. SPONSOR/MONITOR'S REPORT NUMBER(S)	
12. DISTRIBUTION/AVAILABILITY STATEMENT <b>Approved for public release; distribution unlimited</b>					
13. SUPPLEMENTARY NOTES <b>2010 International Symposium on Spectral Sensing Research, June 21-24, 2010, Springfield, MI. U.S. Government or Federal Rights License</b>					
14. ABSTRACT					
15. SUBJECT TERMS					
16. SECURITY CLASSIFICATION OF:			17. LIMITATION OF ABSTRACT <b>Same as Report (SAR)</b>	18. NUMBER OF PAGES <b>20</b>	19a. NAME OF RESPONSIBLE PERSON
a. REPORT <b>unclassified</b>	b. ABSTRACT <b>unclassified</b>	c. THIS PAGE <b>unclassified</b>			

# Overview

- **Objective: Improve standoff range and chem-bio agent detection limits of direct detection LWIR differential absorption LIDAR systems**
  - Standoff range: ~ 2x increase for fixed chem-bio sensitivity; scales as  $1/\sqrt{\text{NEP}}$
  - CB agent sensitivity: ~ 4x increase for fixed standoff range, scales as NEP
  - Compatible with 200 Hz line-tuned CO<sub>2</sub> laser
- **Technical Approach:**
  - Develop ultra-low noise receiver module (RM)
  - Critical elements of receiver design – required to achieve objectives:
    - Reduce baseline (background) photon flux on detector: Tunable Fabry-Perot etalon in optical train
    - Reduce input-referenced amplifier noise: custom amplifier
    - Reduce detector dark current: High impedance detector
- **Performance Metrics:**
  - Noise equivalent power of receiver system (NEP)
  - Etalon tuning speed/bandwidth and wavelength positioning accuracy
  - Electronics bandwidth

# LIDAR Receiver Concept

## Conceptual Design

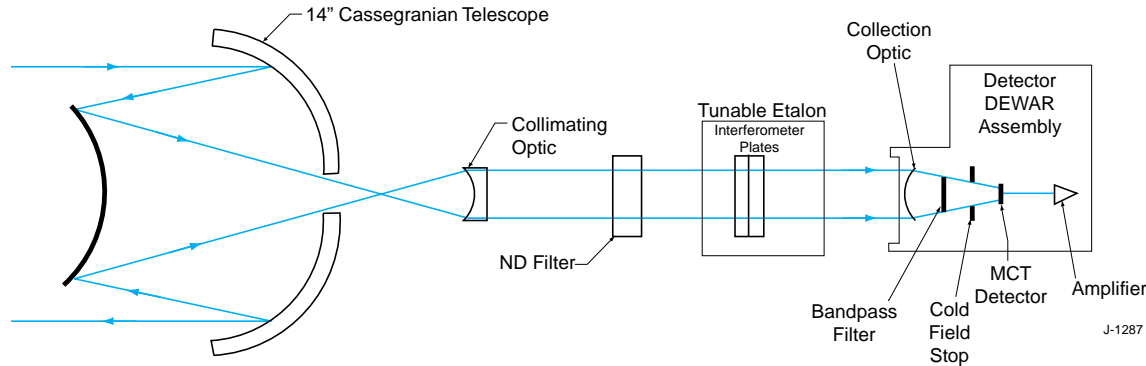

## FP Etalon Transmission

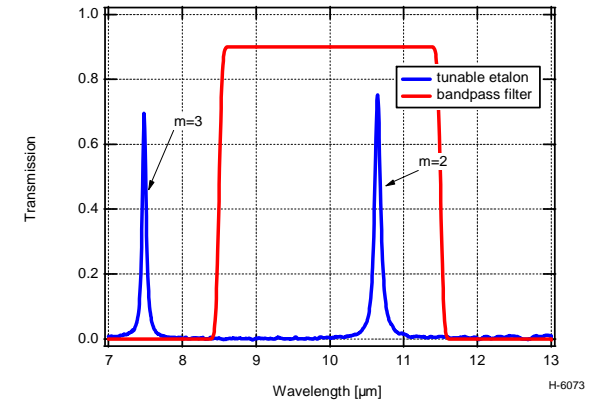

$$NEP_{total} = \left[ NEP_{Jsn+Amp+leak}^2 + NEP_{BLIP}^2 \right]^{1/2}$$

- Single element detector (HgCdTe) with band pass filter coupled to low noise custom amplifier → **reduce  $NEP_{Jsn+Amp+Leak}$**
- Insert tunable Fabry-Perot etalon in afocal region of optical train to reduce baseline flux on detector (~30x reduction) → **reduce  $NEP_{BLIP}$** 
  - Etalon tracks 200 Hz CO<sub>2</sub> laser emission wavelength
  - Tunable etalon is PSI innovation
- f/0.9 optical system for full integration with the existing 14'' Cassegrainian telescope currently employed in the ECBC's FAL system

# Fabry-Perot Etalon: Overview

- **Reduction of baseline flux on detector via tunable etalon insertion reduces system noise**

- Photon statistical noise:  $NEP \propto (\text{flux})^{0.5} / (\text{optics transmission})$

- **Transmission maxima fulfill Fabry-Perot resonance condition:**

$$\lambda_m = \frac{2d}{m}$$

← mirror spacing  
← interference order (integer)

- **Tuning range = Free Spectral Range:**

$$\Delta\lambda \equiv \lambda_{\max,m} - \lambda_{m+1}(\lambda_{\max,m}) \approx \frac{\lambda_{\max,m}}{m+1}$$

- **PSI etalon design:**

- Optics: 50 mm dia x 8 mm thick ZnSe, central 36 mm HR-coated
  - Electronics: FPGA-based control system increases the bandwidth of the etalon control loop and maintains active, continuous alignment of the etalon mirrors (control bandwidth between 2 kHz and 5 kHz)

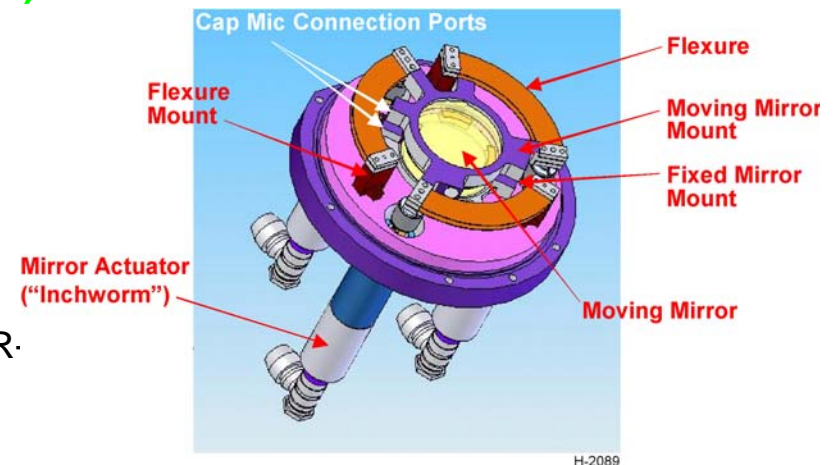
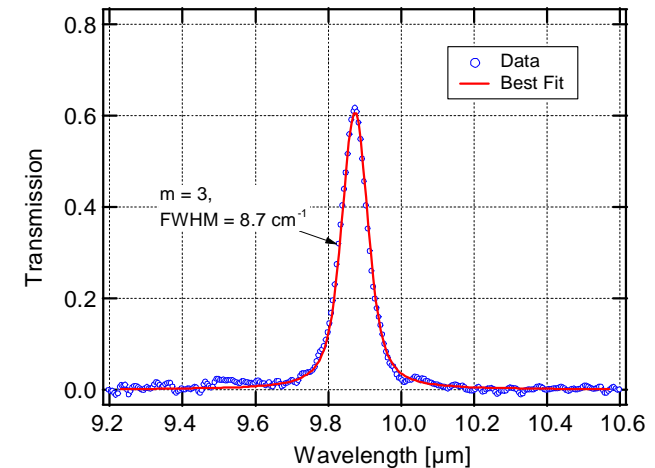

# Fabry-Perot Etalon: Spectral Performance Characteristics

1559 Etalon Performance, December 09

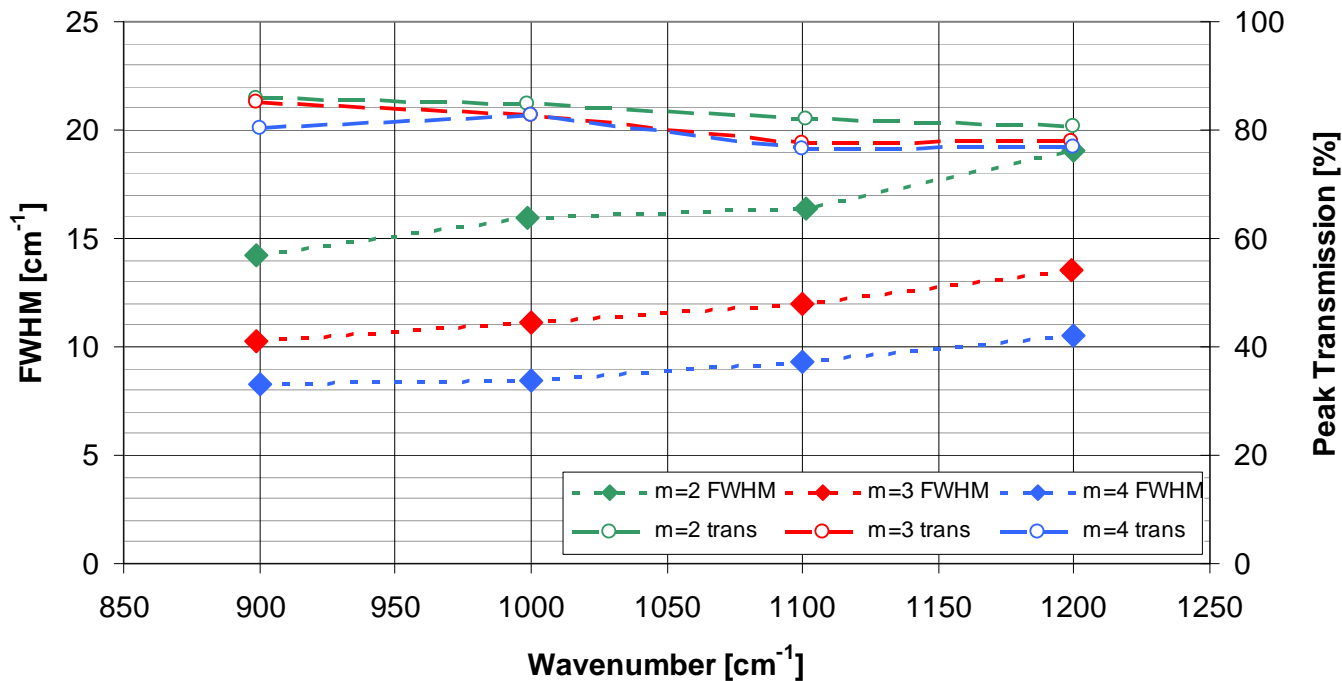

## Conclusions:

- Transmission ~ 80% for all orders across tuning range
- FWHM (m=2): 15 – 19  $\text{cm}^{-1}$
- FWHM (m=3): 10 – 14  $\text{cm}^{-1}$
- FWHM (m=4): 8 – 11  $\text{cm}^{-1}$

# Fabry-Perot Etalon: Derived Requirements

VG10-117-5

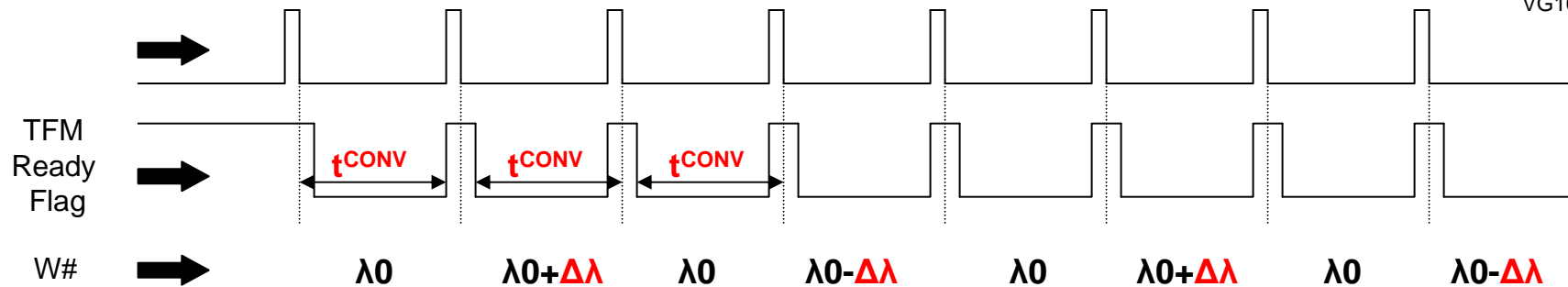

- **Etalon transmission fringe needs to track CO<sub>2</sub> emission wavelength**
  - 200 Hz laser → etalon needs to reach commanded wavelength in < 5 msec
  - CO<sub>2</sub> laser lines:
    - Four branches: 9R, 9P, 10R, 10P
      - ~ 50% CO<sub>2</sub> lines require < 5 cm<sup>-1</sup> jumps
      - ~ 80% CO<sub>2</sub> lines require < 10 cm<sup>-1</sup> jumps
- **Achieve < 1% transmission error due etalon wavelength position uncertainty**
  - If the transmission varies from shot to shot, then the wavelength variation aliases as measurement noise and degrades CB agent detection sensitivity

$$\sigma_p \propto \frac{\sigma_{I/I_0}}{(I/I_0)} = \frac{\sigma_T}{T}$$

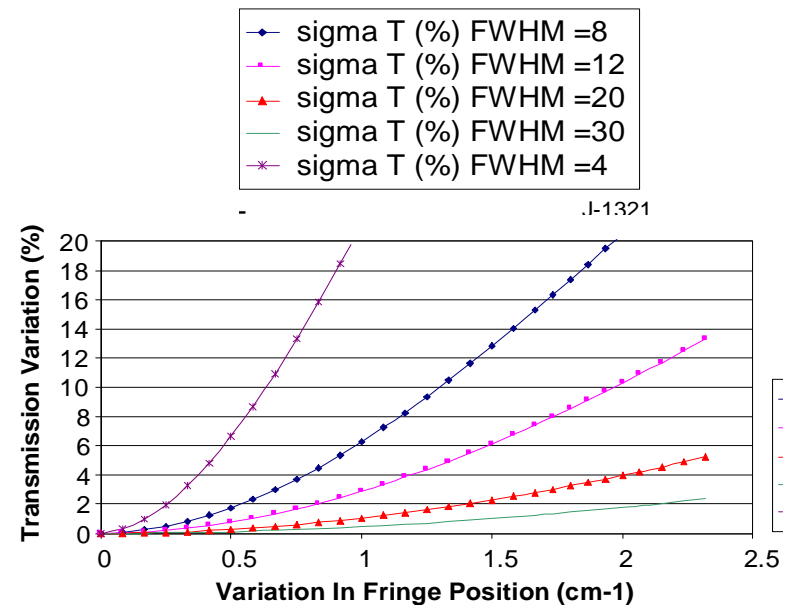

# Fabry-Perot Etalon: Tuning Speed

VG10-117-6

	m=2	m=3	m=4
5cm <sup>-1</sup> Jump	< 4ms	< 3.5ms	< 3ms
10cm <sup>-1</sup> Jump	< 5ms	< 4ms	< 4ms
40cm <sup>-1</sup> Jump	< 10ms	< 15ms	< 20ms
ECBC Wavelength List	< 5ms (80%)	< 5ms (85%)	< 5ms (85%)

- **Etalon Tuning Performance:**

- Less than 5 ms convergence time for 10cm<sup>-1</sup> and smaller jumps
- Technical requirement successfully achieved
- Non-lasing laser trigger pulses are required for jumps greater than 10cm<sup>-1</sup>
  - Slightly reduced the system duty cycle

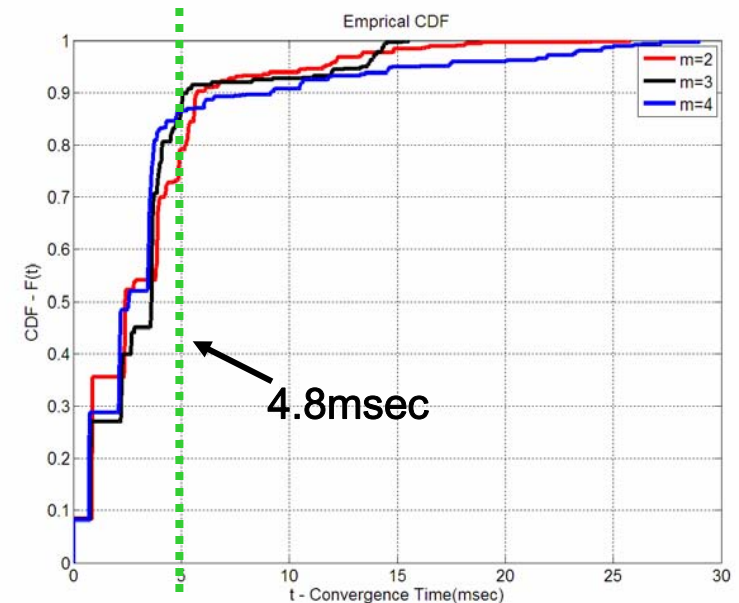
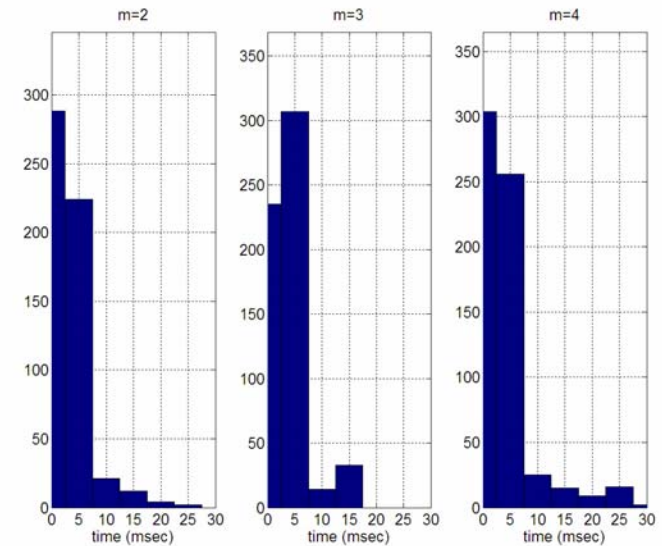

# Fabry-Perot Etalon:

## Transmission Uncertainty Measurements (1)

VG10-117-7

- **Make use of Quantum Cascade Laser (QCL, Maxion P/N M784) which emits at 9.6  $\mu\text{m}$** 
  - Direct measurement of the desired performance one can expect with the ECBC's FAL CO<sub>2</sub> laser
  - Multiple etalon scans over laser line
- **Laser output was directed onto a roughened gold scattering screen**
  - QCL was mounted to a cooling block and directed through a collimating lens onto the screen
  - A N<sub>2</sub>(l)-cooled LWIR camera was used to monitor the onset of lasing and to adjust the lens
- **The laser power supply was modulated with a square wave to +/- 30mA at 10 kHz**
  - Laser turned on and off in a binary fashion with a 50% duty cycle
  - Produced a detectable AC signal well above the detector's high pass cutoff frequency of 500 Hz

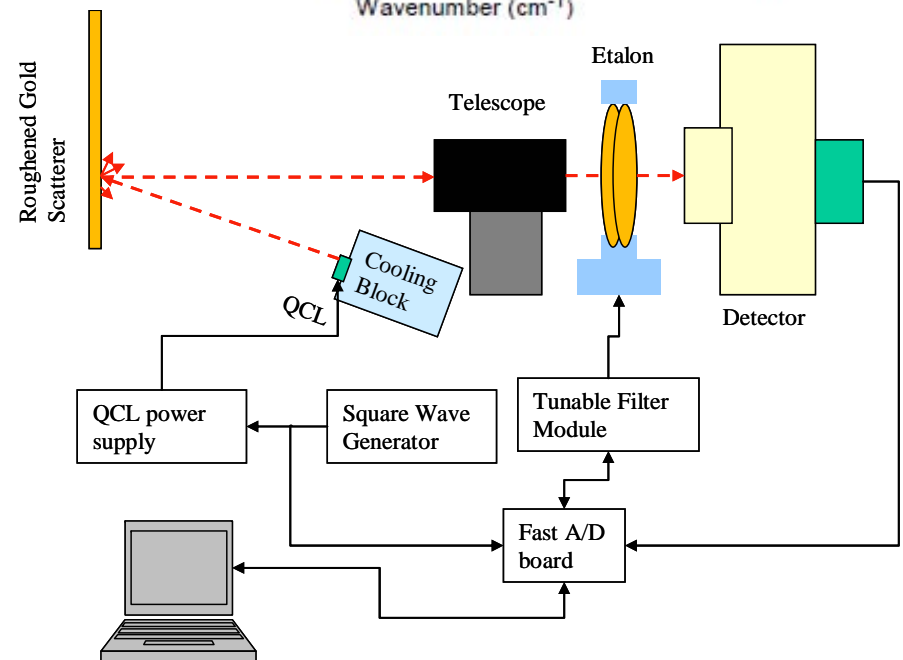
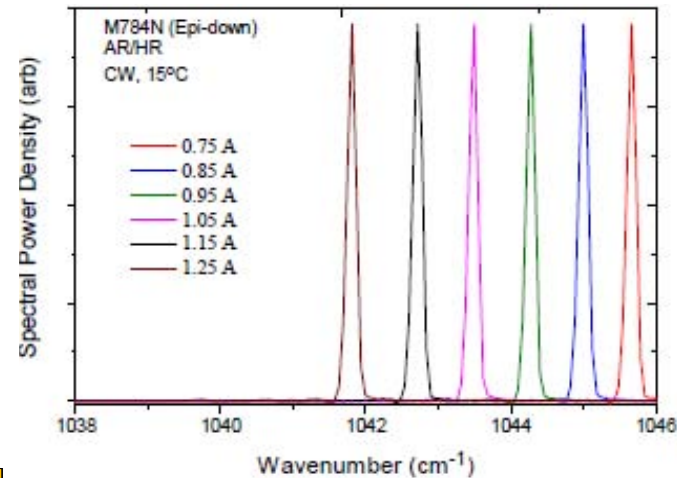

# Fabry-Perot Etalon:

## Transmission Uncertainty Measurements (2)

- The QCL emission is significantly narrower than the etalon transmission bandwidth
  - Shape of the peak represents the etalon transmission function
- Each wavelength data point is an average of 32 separate measurements (etalon scans) and error bars are the standard deviation:

$$\% Error = \left( \frac{\sigma(stdev)}{Mean} \right) \cdot 100$$

- The transmission error due to etalon wavelength position uncertainty is ~ 0.5%
  - Successfully meet derived requirement
- The etalon convergence criteria is determined based on optimization of both tuning speed and position accuracy

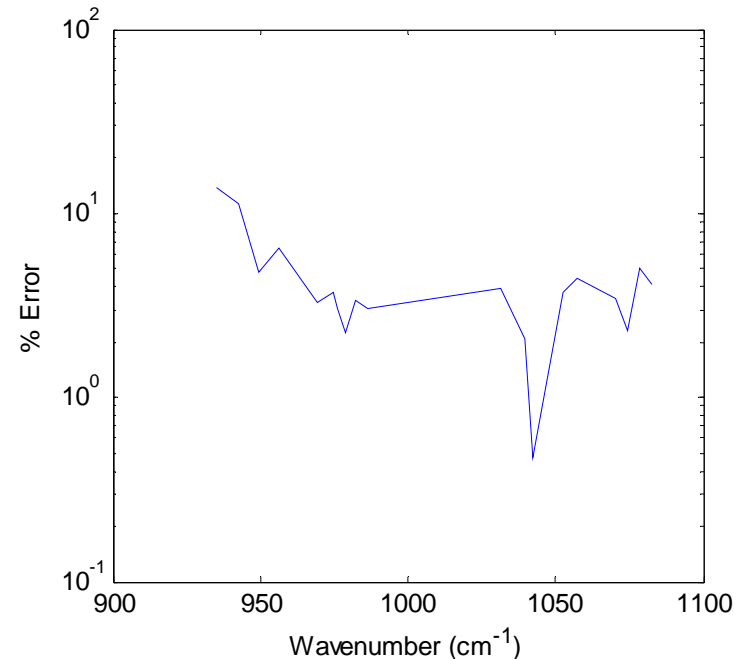
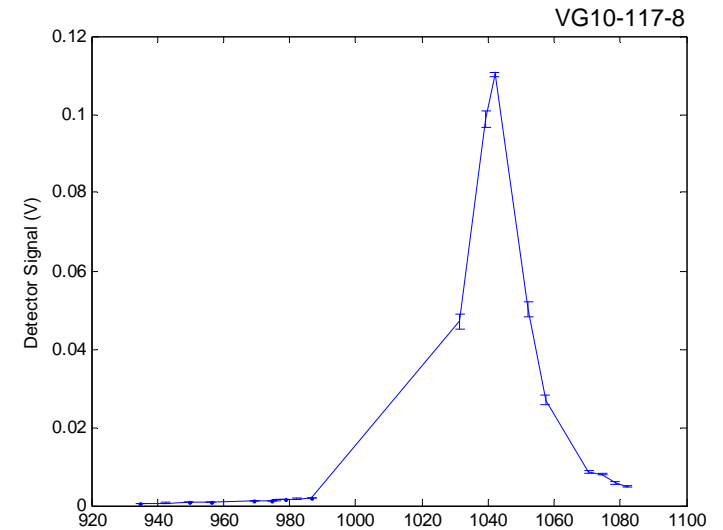

# Detector

- **Judson single element PVMCT, 0.5 mm diameter**
  - Capacitance ~ 200 pF
  - 77K resistance @ 0 VDC: 11 k $\Omega$
- **The detector mounting bracket was custom designed to support the integration of the collection lens assembly inside the dewar for reduction of self-radiance of optical components**

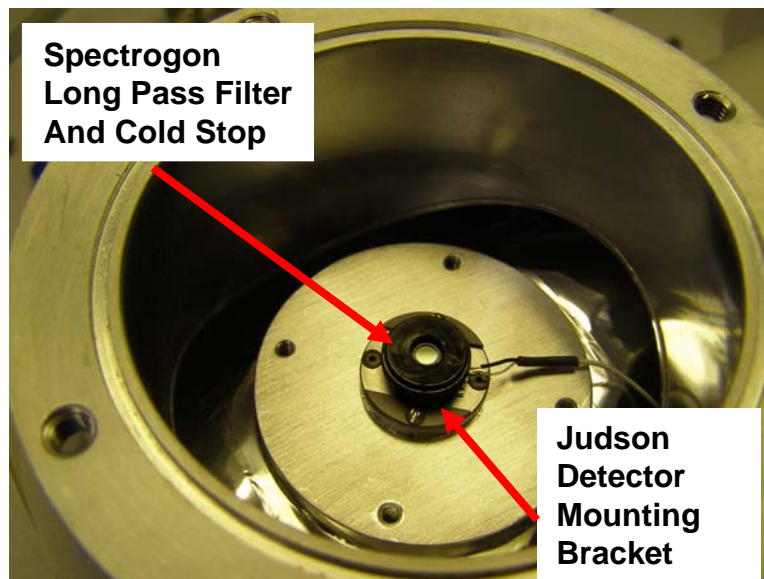

**Lens and cold filter/stop  
Mounting bracket**

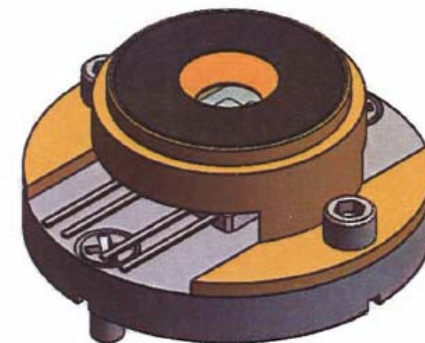

# Custom Preamplifier

VG10-117-10

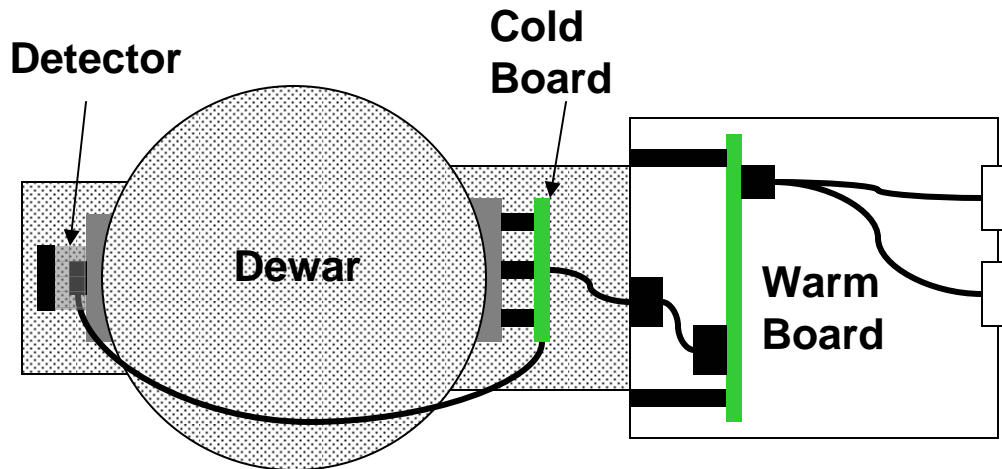

	Single Ended	Differential
Signal Bandwidth	>5MHz (Pref. 20MHz)	>5MHz (Pref. 20MHz)
Output Voltage Range	+3V to -3V	+/-1.13V
Common Mode Voltage	N/A	0V
TIA Gain	200k $\Omega$ / 50k $\Omega$	20k $\Omega$ / 5k $\Omega$
Output Connector & Cable	Triaxial	Triaxial (2X)
Termination Resistance	50 $\Omega$	50 $\Omega$
Bias	0V to -350mV – Pot Adjusted	
Voltage Noise	~ 0.8nV/√Hz	
Cold PCB Temperature	140K to 180K	
Power Dissipated on Cold PCB	< 650mW	
Warm PCB Size	3.5" X 2.5"	
Cold PCB Size	1" Diameter	
Power Requirements	+/-15V, <5mVrms noise, <200mA	

- The transimpedance preamplifier architecture was optimized around the selected IR detector diode
  - Input-referenced noise density of 0.8 nV/ Hz<sup>0.5</sup>
- A portion of the preamplifier was physically located within the cryogenic dewar with the IR photodiode
  - Stage consists of a JFET transistor with the detector attached to its gate
    - Thermal noise from this stage and any stray capacitance at the input are reduced
    - Reductions help to lower the input referred noise added by the preamplifier.
- The other portion of the preamplifier was located directly outside the dewar and was operated at room temperature
  - The majority of the preamplifier circuitry is located on this PCB
    - Circuitry to control and adjust bias condition
    - Monitor dewar temperatures
    - Buffer the preamplifier output

# Optical Layout: Designed for Retrofitting into Existing FAL Receiver

VG10-117-11

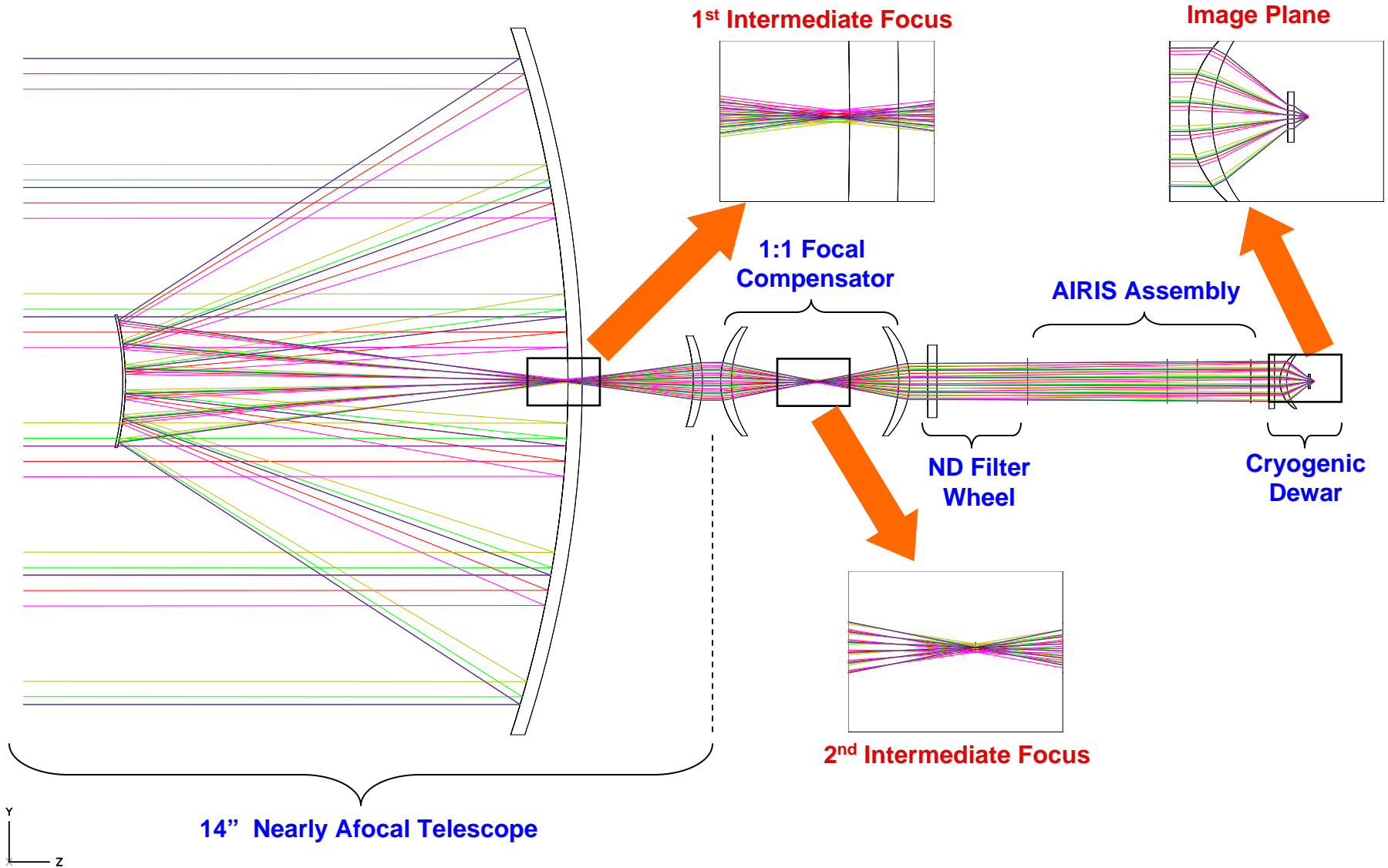

# Receiver Module Mechanical Configuration

VG10-117-12

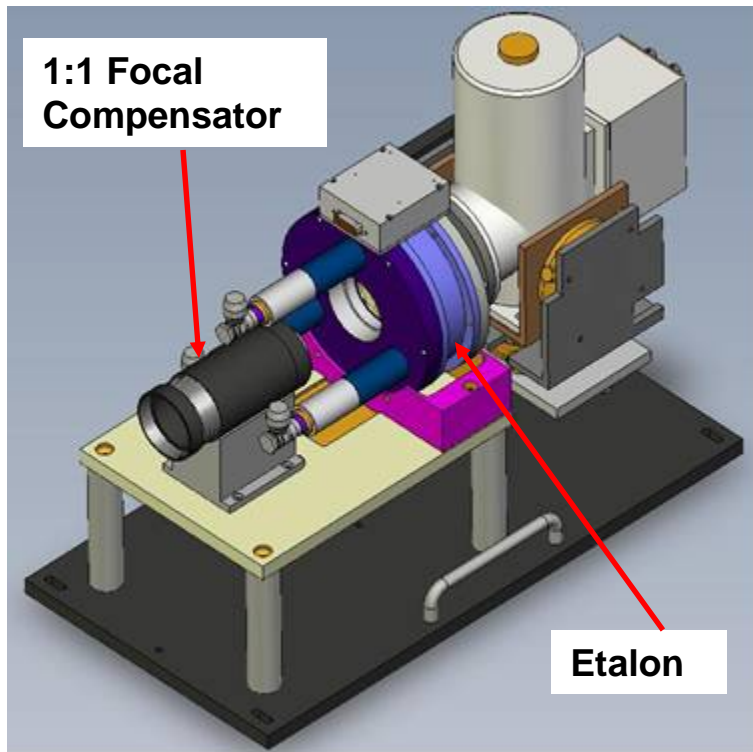

## Detector Mounting Stage

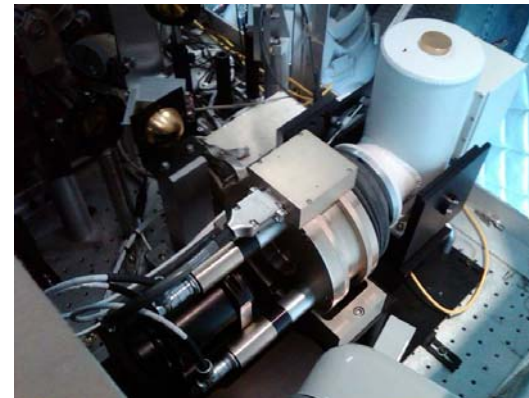
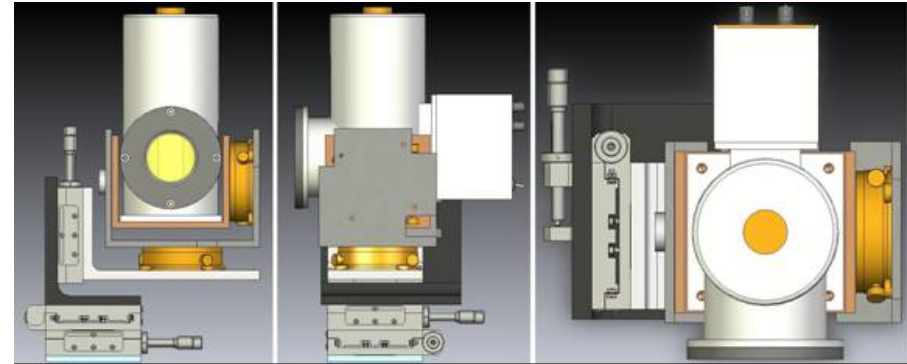

- Assembly designed for ease of integration into FAL system
- Detector mounted on a Yaw, Tilt, XYZ translation stage for easy optical alignment

# FAL Receiver Module: Performance Characterization, System Model

- **Model system performance**
  - Model developed in Matlab
  - Model calculates  $NEP_{BLIP}$  given specific system input parameters
- **System NEP improvement most significant when observing warmer backgrounds which add significantly to the BLIP noise**
  - ~37% improvement at  $T_{bkgd}=400K$
  - ~6% improvement at  $T_{bkgd} = 266K$

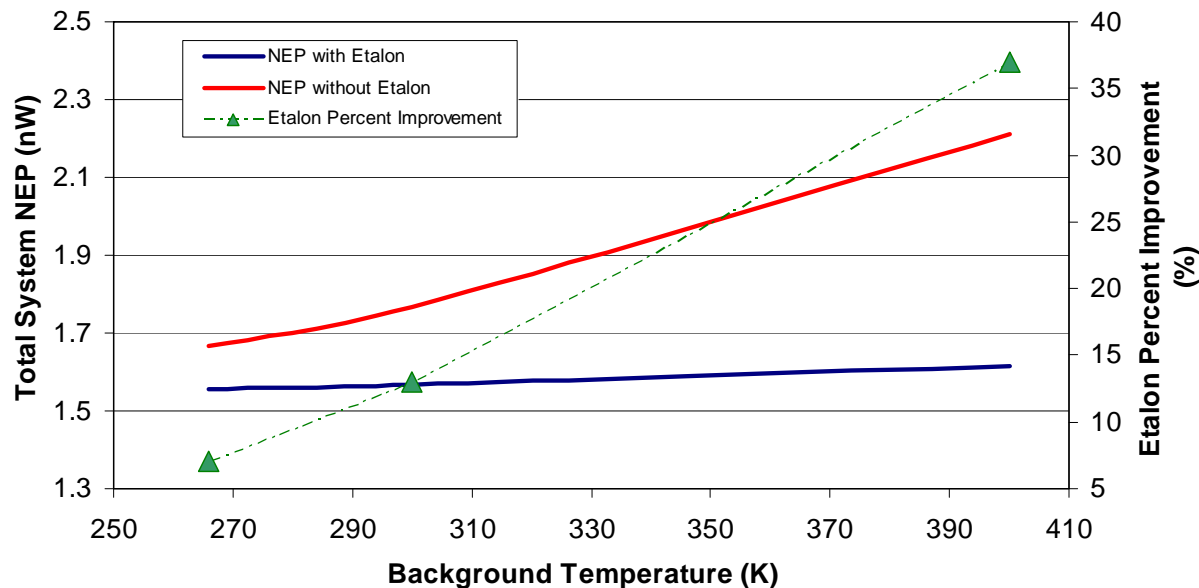

- **Experimentally determine system NEP for an electronic bandwidth of 5 MHz and compare with model predictions**

# FAL Receiver Module: NEP Asymptote Measurement

- **Measure NEP contributed by detector thermal noise and preamp. noise (Johnson, voltage, current and leakage noise) – no BLIP noise**
  - Replace cooled lens with blackened piece of aluminum
- **Capture noise density using spectrum analyzer (PSD)**

$$\Rightarrow NEP_{total} = \left[ NEP_{Thermal+AmpV,I,Js n+Leak}^2 + \underbrace{NEP_{BLIP}^2}_{\sim 0} \right]^{1/2}$$

$$\Rightarrow NEP_{total} = \frac{1}{R} \left[ \int_0^{5MHz} PSD(f) df \right]^{1/2}$$

	Gain (Low)	Gain (High)	Bandwidth	NEP (@ 80K) 5 MHz, High Gain
Single Ended	52.98kΩ	213.1kΩ	~16MHz	<b>1.54 nW</b>
Differential	4.64kΩ	18.56kΩ	~20MHz	*

# FAL Receiver Module: NEP<sub>BLIP</sub> Measurement

VG10-117-15

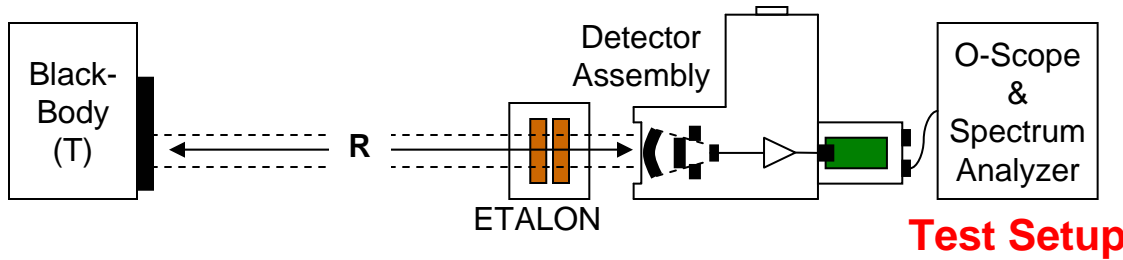

$$NEP_{BLIP} (nW) = \frac{\sqrt{(RMS_{Total})^2 - (RMS_{Gold\_Mirror})^2}}{D_{responsivity} (A/W) \cdot Gain(k\Omega) \cdot (10^6)}$$

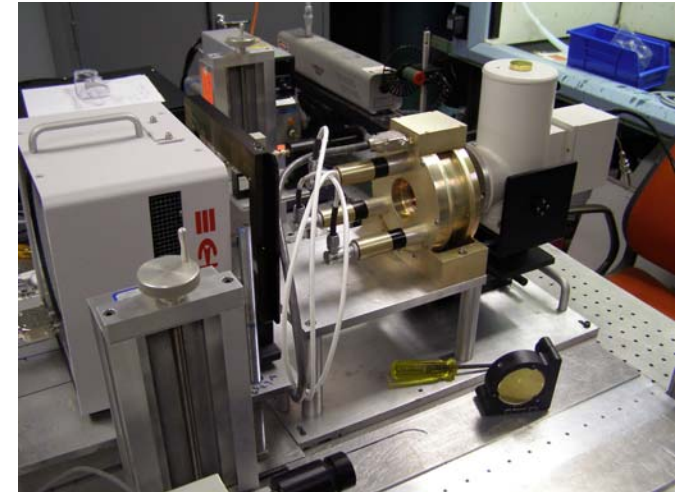

- Measure noise baseline by observing gold mirror (looking at ~77K target) positioned in front of detector window
- Tune Etalon to a single wavelength and observe 400K Blackbody
- Measure total NEP using noise PSD captured by spectrum analyzer (or RMS noise on O-scope) with and without etalon inserted in the optical train
- Calculate NEP<sub>BLIP</sub> with and without etalon

## O-scope RMS Noise, Etalon @ m=2

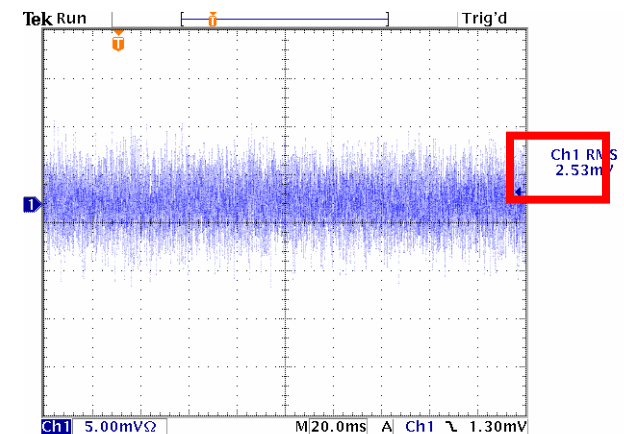

14 Nov 2008  
15:06:43

# FAL Receiver Module: Performance Characterization Summary

@5MHz, $T_{\text{bkgd}}=400\text{K}$	m=2	m=3	m=4	No Etalon
NEP-Det/Preamp	1.54nW	1.54nW	1.54nW	1.54nW
NEP-Blip (Measured)	0.73nW	0.64nW	0.61nW	1.86nW
NEP-Blip (Modeled)	0.48 nW			1.59nW
Measured NEP <sub>total</sub>	1.70nW	1.67nW	1.66nW	2.42nW
Modeled NEP <sub>total</sub>	1.61nW			2.21nW

- **Objective: NEP  $\leq$  1.5nW for 5 MHz bandwidth**
- **Overall NEP is ~13% higher than design goal**
  - Higher detector capacitance than expected increased NEP
- **Measured NEP improvement through the use of etalon consistent with expected performance**
  - ~ 37% NEP improvement when  $T_{\text{bkgd}}=400\text{K}$

# RM Integration into FAL System

VG10-117-17

- **Receiver Module (RM) transported to ECBC for full system integration**
  - Dec 16 – 18, 2009
- **Successfully performed system optical alignment**
  - Developed alignment procedure
  - Demonstrated the ability to remove RM in & out and retain the integrity of the optical alignment
- **Successfully integrated RM/TFM with FAL software/hardware**
  - Confirmed TFM can be controlled by FAL software
    - Using DLL functions developed by PSI
  - Characterized integrated TFM operation (with FAL laser on)
    - TFM Convergence time and sigma values
    - Burst and Laser Triggers – with non-lasing triggers inserted
    - Etalon scanning and transmission measurements error against known FAL laser line/s

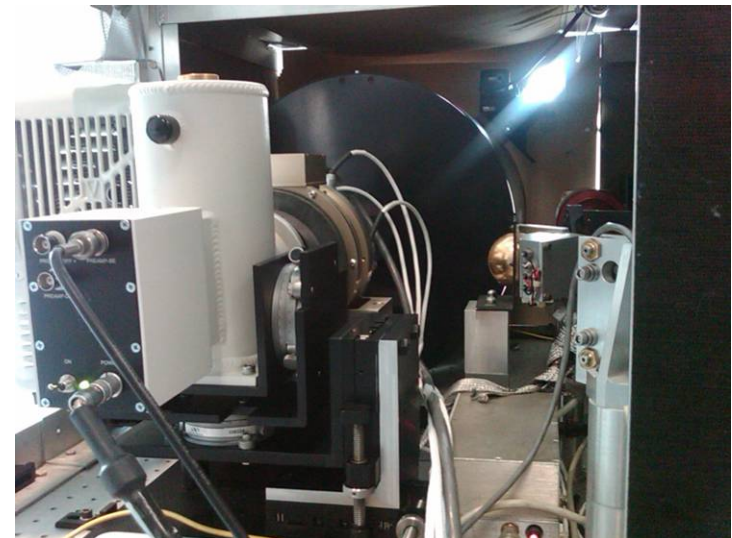
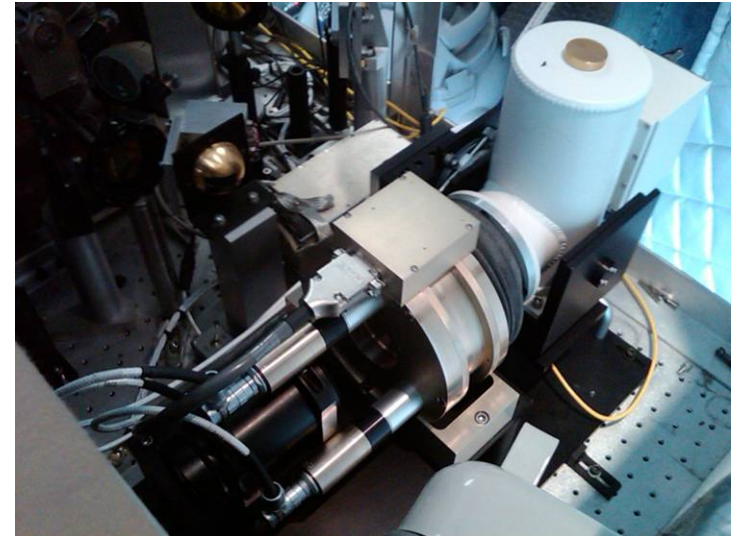

# RM/FAL System: Performance Characterization

VG10-117-18

- **Performed system characterization**
  - Goal: Characterize FAL/RM system noise and overall improvement due to the use of the etalon
- **Targets:**
  - Hard target @ ~ 400 m (tree branch)
  - $T_{\text{bgd}} \sim 266\text{K}$
- **System Measurements:**
  - Single laser shots (10R20) with etalon fixed at  $975\text{ cm}^{-1}$
  - Single laser shots (10R20) with etalon tuning across the laser line
  - Laser scanning (9 lines) with etalon synced and scanning
- **Blip noise measurements are made by analyzing the noise in the digitizer's traces in the absence of laser light**
- **Analyzed noise gives a good estimation of the Noise Equivalent Voltage, which can be converted to NEP**
  - It is important that laser returns be negligible by  $t_1$  so that the time dependent laser return signal does not contribute to the measured noise.
  - Results demonstrate a ~ 6% NEP improvement through the use of PSI's etalon in the FAL system
  - Results consistent with modeling predictions when system observing a  $T_{\text{bgd}} \sim 270\text{ K}$
- **RM successfully demonstrated expected BLIP noise reduction**

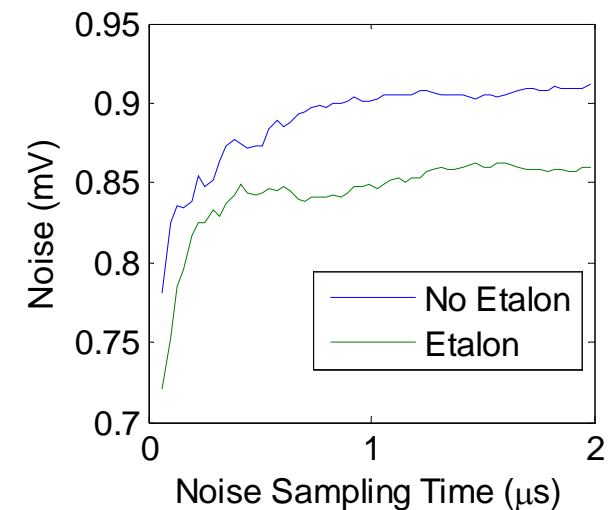
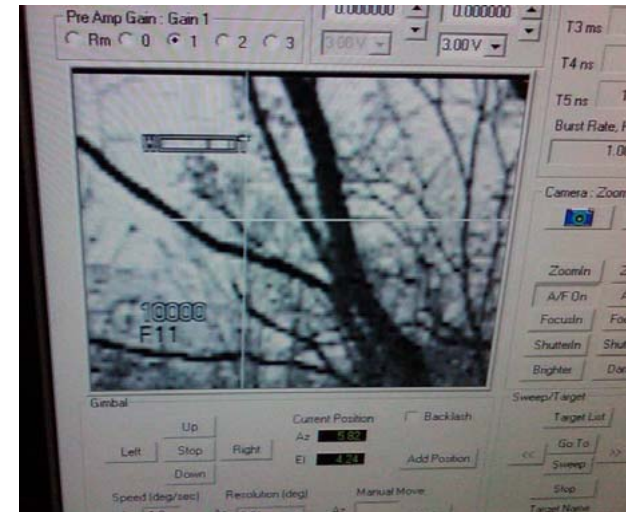

# Conclusions

- **Successfully developed low noise receiver module for FAL**
- **Receiver module is fully compatible with 200 Hz line tuned CO<sub>2</sub> laser**
- **Receiver module achieves total system NEP ~ 1.7 nW for an electronic bandwidth of 5 MHz**
- **NEP<sub>Blip</sub> reduction consistent with modeling predictions**
- **Receiver module was successfully integrated with the ECBC's FAL system**