



NRL/MR/6180--11-9328

Volume Sensor Canadian Demonstrator Prototype User's Guide

DANIEL A. STEINHURST
CHRISTIAN P. MINOR

*Nova Research, Inc.
Alexandria, Virginia*

STEPHEN C. WALES
THOMAS BURCHFIELD

*Acoustic Signal Processing Branch
Acoustics Division*

SUSAN L. ROSE-PEHRSSON

*Navy Technology Center for Safety and Survivability
Chemistry Division*

March 23, 2011

Approved for public release; distribution is unlimited.

REPORT DOCUMENTATION PAGE

Form Approved
OMB No. 0704-0188

Public reporting burden for this collection of information is estimated to average 1 hour per response, including the time for reviewing instructions, searching existing data sources, gathering and maintaining the data needed, and completing and reviewing this collection of information. Send comments regarding this burden estimate or any other aspect of this collection of information, including suggestions for reducing this burden to Department of Defense, Washington Headquarters Services, Directorate for Information Operations and Reports (0704-0188), 1215 Jefferson Davis Highway, Suite 1204, Arlington, VA 22202-4302. Respondents should be aware that notwithstanding any other provision of law, no person shall be subject to any penalty for failing to comply with a collection of information if it does not display a currently valid OMB control number. **PLEASE DO NOT RETURN YOUR FORM TO THE ABOVE ADDRESS.**

1. REPORT DATE (DD-MM-YYYY) 23-03-2011		2. REPORT TYPE Memorandum Report		3. DATES COVERED (From - To) December 1, 2009 - December 1, 2010	
4. TITLE AND SUBTITLE Volume Sensor Canadian Demonstrator Prototype User's Guide				5a. CONTRACT NUMBER CN-P-FBQ	
				5b. GRANT NUMBER	
				5c. PROGRAM ELEMENT NUMBER	
6. AUTHOR(S) Daniel A. Steinhurst,* Christian P. Minor,* Stephen C. Wales, Thomas Burchfield, and Susan L. Rose-Pehrsson				5d. PROJECT NUMBER	
				5e. TASK NUMBER	
				5f. WORK UNIT NUMBER 61-9818-0-0-5	
7. PERFORMING ORGANIZATION NAME(S) AND ADDRESS(ES) Naval Research Laboratory, Code 6181 4555 Overlook Avenue, SW Washington, DC 20375-5320				8. PERFORMING ORGANIZATION REPORT NUMBER NRL/MR/6180--11-9328	
9. SPONSORING / MONITORING AGENCY NAME(S) AND ADDRESS(ES) Defense R&D Canada Atlantic Attn: Dr. John A. Hiltz Dockyard Laboratory (Atlantia) Section, Materials Chemistry Group PO Box 99000 Station Forces Halifax, Nova Scotia, Canada B3K 5X5				10. SPONSOR / MONITOR'S ACRONYM(S)	
				11. SPONSOR / MONITOR'S REPORT NUMBER(S)	
12. DISTRIBUTION / AVAILABILITY STATEMENT Approved for public release; distribution is unlimited.					
13. SUPPLEMENTARY NOTES *Nova Research, Inc., 1900 Elkin Street, Suite 230, Alexandria, VA 22308					
14. ABSTRACT The purpose of this document is to describe the installation and the operation of the Volume Sensor–Canadian Demonstrator Prototype (CDP). The Volume Sensor (VS) is a prototype fire and smoke detection and situational awareness system developed at the U.S. Naval Research Laboratory (NRL). The VS prototype has been repackaged into a standalone unit with two sensor heads for evaluation by the Canadian Navy. This document is broken into several sections. The first sections are intended to introduce the CDP and set the scope of this document. Next, the process of installation of the CDP and its various components is discussed. The next section describes how to operate the Volume Sensor for real-time demonstrations and also describes the situational awareness provided by the system.					
15. SUBJECT TERMS Detection system Machine vision Damage control Multi-sensory detection Image analysis Situational awareness Data fusion Fire detection					
16. SECURITY CLASSIFICATION OF:			17. LIMITATION OF ABSTRACT	18. NUMBER OF PAGES	19a. NAME OF RESPONSIBLE PERSON Susan L. Rose-Pehrsson
a. REPORT Unclassified	b. ABSTRACT Unclassified	c. THIS PAGE Unclassified			UL

NOTICES

Manual Version	Date	Description
1.0	December 1, 2010	Draft Document Release
1.1	December 10, 2010	Final Document Release

Contact Information

U.S. Naval Research Laboratory
4555 Overlook Ave., SW
Washington DC 20375

Susan Rose-Pehrsson
Navy Technology Center for Safety and Survivability
Chemistry Division
(202) 767-3138

Table of Contents

NOTICES.....	iii
Table of Contents.....	v
Figures.....	viii
Tables.....	xiii
File Listings	xiii
1. Purpose of Document.....	1
2. Introduction.....	1
3. Additional Information	2
4. System Description	2
4.1. System Overview.....	2
4.2. Canadian Demonstrator Prototype Sensor Head.....	3
5. System Installation.....	5
5.1. Sensor Location	7
5.2. Sensors.....	8
5.3. Computers.....	12
5.4. Optical Subsystem	14
5.5. Audio Subsystem	15
5.6. <i>SigniFire</i> - Machine Vision Subsystem.....	17
5.7. Network Subsystem	17
6. System Operation.....	18
6.1. Power-on Procedure.....	19
6.2. Software Launch	19
6.3. Data Fusion and UI Software Launch.....	22
6.4. Component System Verification Testing.....	24
6.5. Demonstration Procedures.....	32
6.6. Situational Awareness.....	35
6.7. Data Output.....	40
6.8. System Shutdown.....	41
7. Spectral-Based Volume Sensor (SBVS) Component	42

7.1. SBVS Data Acquisition Electronics	43
7.2. SBVSLogger Software.....	45
7.3. SBVSLogger Standard Configuration	46
7.4. SBVSLogger Extended Configuration	49
7.5. SBVSLogger Operation.....	50
7.6. Sensor Head Calibration	52
8. Long-Wavelength Video Detection (LWVD) Component.....	53
8.1. LWVD Data Acquisition Electronics	53
8.2. LWVD Software	55
8.2.1. LWVD Configuration	57
8.2.2. LWVD Operation.....	58
8.2.3. LWVD Data Files.....	61
9. Acoustics (ACST) Component	62
9.1. Acoustics Hardware and Processing Overview	62
9.2. Acoustics Processing Software and Control Files	65
9.2.1. Acoustics Processing.....	65
9.2.2. Software and Control Files.....	67
9.3. Acoustic Installation and Operating Instructions.....	68
9.3.1. Hardware Installation Instructions	68
9.3.2. Software Installation and Operating Instructions.....	69
9.4. Testing Mode	69
10. SigniFire Machine Vision (VID) Component	71
10.1. SigniFire IP Physical Configuration.....	71
10.2. System Startup	73
10.2.1. SpyderGuard IP Startup	74
10.2.2. VSCS.Bridge Startup.....	78
10.2.3. SigniFire IP Camera Zone Configuration	80
10.3. Video Recording	81
11. Volume Sensor Quad-View (VS_Quad) Software	82
11.1. VS_Quad Software	82
11.1.1. VS_Quad Configuration.....	83

11.1.2. VS_Quad Operation	84
12. Volume Sensor Command and Control (VS_CnC) Software.....	84
12.1. VS_CnC Software.....	84
12.2. Operation.....	85
12.3. Configuration.....	86
12.4. VS_CnC Communications Interface Configuration	86
12.5. Data Logging	87
13. Volume Sensor Graphical User Interface (VS_GUI) Software.....	88
13.1. VS_GUI Software.....	88
13.2. Operation.....	88
13.3. Situational Awareness.....	92
13.3.1. The LOG Window	92
13.3.2. The SENSOR SUBSYSTEM Window	93
13.3.3. The SENSOR ALARM Windows.....	94
13.3.4. The VS ALGORITHMS Window	95
13.3.5. The FUSION ALARM TIMES Window	96
13.3.6. The NUISANCE DATA TABLE Window	97
14. System Component Specifications	98
15. References.....	99

Figures

Figure 4-1 – Volume Sensor Demonstrator Prototype Components and Connections	3
Figure 4-2 – Front View of the Canadian Demonstrator Prototype Sensor Head	4
Figure 4-3 – Internal View of the Canadian Demonstrator Prototype Sensor Head	4
Figure 5-1 – Volume Sensor Demonstrator Prototype Components and Connections	6
Figure 5-2 – Typical installation of a CDP Sensor Suite.....	7
Figure 5-3 – Volume Sensor Placement During CDP Shakedown Testing.....	8
Figure 5-4 – Sensor head unit with labeled sensing components	9
Figure 5-5 – (a) Sensor head mount, (b) <i>SigniFire IP</i> Camera mount	9
Figure 5-6 – <i>SigniFire IP</i> machine vision camera.....	10
Figure 5-7 – Cable set for sensor suite #2.....	11
Figure 5-8 – Fusion Machine computer backplane indicating connectors for keyboard, mouse, monitor, and the network, video, and audio subsystems	14
Figure 5-9 – Fieldpoint Unit, (a) power and network, (b) serial data connections.....	15
Figure 5-10 – Schematic View of the Audio Subsystem Components and Connections.....	16
Figure 5-11 – Connections to Phantom Power Supply.....	17
Figure 5-12 – Network subsystem components and cabling	18
Figure 6-1 – Fusion Machine desktop icons for sensor programs	20
Figure 6-2 – <i>SigniFire</i> application desktop icons.....	21
Figure 6-3 – <i>SpyderGuard IP</i> , Server Tab, with Cameras Loaded.....	22
Figure 6-4 – VSCS.Bridge, Cluster Tab	22
Figure 6-5 – Fusion Machine desktop icons for GUI and data fusion programs.....	23
Figure 6-6 – Fusion Machine desktop, configured for CDP operation.....	24

Figure 6-7 – ACST Subsystem Showing an Acoustic Event (Clapping of Hands).....	25
Figure 6-8 – SBVSLogger main screen, system processing incoming data.....	25
Figure 6-9 – SBVSLogger main screen, system detecting a FIRE_FOV EVENT.....	26
Figure 6-10 – Camera Image Quality Verification using VS_Quad Application.....	27
Figure 6-11 – Camera Status Verification using VS_Quad Application.....	27
Figure 6-12 – LWVD main screen, system processing incoming data.....	28
Figure 6-13 – LWVD main screen, system in FLAME pre-alarm state.....	29
Figure 6-14 – LWVD main screen, system in a FLAME alarm state.....	30
Figure 6-15 – <i>SpyderGuard IP</i> Camera Browser screen, system in a normal state.....	31
Figure 6-16 – <i>SpyderGuard IP</i> Camera Browser screen, system in a FLAME alarm state	31
Figure 6-17 – CDP operator view after a clean system startup	33
Figure 6-18 – Main VS_GUI Interface Controls – Pre-Initialization.....	33
Figure 6-19 – CDP operator view after Initialization.....	34
Figure 6-20 – Main VS_GUI Interface Controls – Ready to Start	34
Figure 6-21 – CDP operator view with CDP collecting data.....	35
Figure 6-22 – Main VS_GUI Interface Controls – Running	35
Figure 6-23 – VS_GUI indicating an LWVD-based FLAME pre-alarm condition.....	36
Figure 6-24 – VS_GUI indicating an LWVD-based FLAME alarm condition.....	37
Figure 6-25 – VS Data Fusion Algorithms declaring a FLAME event based on the LWVD and SBVS subsystems	38
Figure 6-26 – VS_GUI Nuisance Data Table.....	40
Figure 6-27 – VS_GUI Nuisance Data Table indicating People in the Space.....	40
Figure 6-28 – Desktop Shortcuts for Data Archiving.....	41
Figure 7-1 – SBVS Fieldpoint Unit	43

Figure 7-2 – Interior View of SBVS Fieldpoint Unit	43
Figure 7-3 – Schematic Wiring Diagram for the SBVS Component.....	44
Figure 7-4 – SBVSLogger main screen, system idle.....	46
Figure 7-5 – SBVSLogger Data Logging Options Screen.....	47
Figure 7-6 – SBVSLogger Device Connection Options Screen.....	48
Figure 7-7 – SBVSLogger System Definitions Options Screen.....	49
Figure 7-8 – SBVSLogger Setup Screen	50
Figure 7-9 – SBVSLogger main screen, system collecting background data.....	51
Figure 7-10 – SBVSLogger main screen, system processing incoming data.....	51
Figure 7-11 – SBVSLogger main screen, system detecting a FIRE_FOV EVENT.....	52
Figure 7-12 – Senseware T-229/1 UV/IR OFD test lamp	53
Figure 8-1 – Schematic Wiring Diagram for the LWVD Component.....	54
Figure 8-2 – External View of Frame Grabber Backplane with Inputs Labeled	54
Figure 8-3 – LWVD main screen, LWVD mode, system idle, no data acquisition	56
Figure 8-4 – Video Source Configuration Screen, NTSC format selected.....	58
Figure 8-5 – LWVD main screen, system processing incoming data.....	59
Figure 8-6 – LWVD main screen, system in FIRE pre-alarm state.....	60
Figure 8-7 – LWVD main screen, system in a FIRE alarm state	61
Figure 9-1 – System overview of the acoustics data acquisition and processing for the Canadian Demonstrator Prototype system.....	63
Figure 9-2 – Front view of the Canadian Demonstrator Prototype Sensor Unit with the acoustics sensor in the upper right corner.	63
Figure 9-3 – Rear view of the Canadian Demonstrator Prototype Sensor Unit with the acoustics cables and connectors in front.....	64

Figure 9-4 – Computer connections showing the acoustics A/D card (on bottom), connecting cables, and the phantom power supply.	65
Figure 10-1 – <i>SigniFire IP</i> Camera a) ¾ profile view b) rear view.....	71
Figure 10-2 – General Settings page on CDP Camera #1’s internal webserver.....	72
Figure 10-3 – <i>SpyderGuard IP</i> , Server Tab, with Cameras Loaded.....	73
Figure 10-4 – VSCS.Bridge, Cluster Tab	74
Figure 10-5 – <i>SpyderGuard IP</i> on Application Start, Server Tab	75
Figure 10-6 – <i>SpyderGuard IP</i> on Application Start, Browser Tab	75
Figure 10-7 – <i>SpyderGuard IP</i> , Server Tab with Server Selected.....	76
Figure 10-8 – “Select Available Camera” Window.....	77
Figure 10-9 – <i>SpyderGuard IP</i> , Browser Tab, with Camera #1 Selected.....	78
Figure 10-10 – VSCS.Bridge, Destination Tab.	79
Figure 10-11 – VSCS.Bridge, Setup Tab.....	80
Figure 10-12 – <i>SigniFire</i> Event Detection Zones.....	81
Figure 11-1 – VS_Quad Main Screen.....	83
Figure 12-1 – VS_CnC Software Main Screen During Demonstration	85
Figure 13-1 – VS_GUI Software Main Screen.....	90
Figure 13-2 – VS_GUI Application (a) Initialization and Start Buttons (b) Stop Button	90
Figure 13-3 – VS_GUI Sensor Subsystem Window, (top) After Initialization, (bottom) Normal Operations.....	91
Figure 13-4 – VS_GUI Software Main Screen With Active FLAME Alarm	92
Figure 13-5 – The VS_GUI LOG Window, (top) Command Messages, (bottom) Data and Algorithm Packets.....	93
Figure 13-6 – The VS_GUI SENSOR ALARM Windows, (top) After Initialization, (bottom) With Active FLAME Alarms.....	95

Figure 13-7 – The VS_GUI VS ALGORITHMS Window, (top) After Initialization, (bottom) With Active Data Fusion FLAME Alarm..... 96

Figure 13-8 – The VS_GUI FUSION ALARM TIMES Window, (top) After Initialization, (bottom) With Active Data Fusion FLAME Alarm..... 97

Figure 13-9 – The VS_GUI NUISANCE DATA TABLE Window after Initialization..... 98

Tables

Table 4-1 – Wiring Connection Pinout for CDP Sensor Head	5
Table 5-1 – Serial Numbers for CDP Sensor Suite Components	10
Table 5-2 – Numbers and color codes for sensor cables	12
Table 6-1 – Audio Events and Alarms.....	39
Table 7-1 – Wiring Connection Pinout for SBVS Fieldpoint Analog Inputs.....	45
Table 7-2 – Wiring Connection Pinout for SBVS Fieldpoint Digital Inputs.....	45
Table 7-3 – Scaled Data Voltages for Standard Test Lamp and Distances	53
Table 9-1 – Audio Events and Alarms.....	66
Table 9-2 – Acoustic Directory Files.....	67
Table 9-3 – Valid Sensor Options.....	68
Table 10-1 – <i>SigniFire IP</i> Camera Details	71
Table 12-1 – VS_CnC Configuration Files	86
Table 12-2 – VS_CnC XML Communications Files.....	87
Table 12-3 – VS_CnC Data Logging Files.....	87

File Listings

File Listing 8-1 – Annotated Version of LWVD1 Configuration File (<code>lwvd1.ini</code>).....	57
File Listing 9-1 – Sensor Identification File, <code>Microphones.id</code>	68
File Listing 9-2 – Sensor Identification File, <code>Microphones.id</code> , with Testing Mode Activated	70
File Listing 11-1 – Annotated Version of the VS_Quad Configuration File (<code>default.ini</code>)..	83

1. Purpose of Document

The purpose of this document is to describe the installation and the operation of the Volume Sensor – Canadian Demonstrator Prototype (CDP). The Volume Sensor (VS) is a prototype fire and smoke detection and situational awareness system developed at the U.S. Naval Research Laboratory (NRL). The VS prototype has been repackaged into a standalone unit with two sensor heads for evaluation by the Canadian Navy.

This document is broken into several sections. The first sections are intended to introduce the CDP and set the scope of this document. Next, the process of installation of the CDP and its various components is discussed. The next section describes how to operate the Volume Sensor for real-time demonstrations and also describes the situational awareness provided by the system. The remainder of the document contains further details about each of the hardware and software components that comprise the CDP.

2. Introduction

The Advanced Volume Sensor (VS) Project was one element of the Office of Naval Research's (ONR) Future Naval Capabilities program, Advanced Damage Countermeasures. This program sought to develop and demonstrate improved damage control (DC) capabilities to help ensure that the recoverability performance goals for new ship programs, such as the CVN21 family of ships, could be met with the specified manning levels and damage control systems. Using a multi-sensory approach, the Naval Research Laboratory (NRL) is developing new detection capabilities for DC in the shipboard environment. Conventional surveillance cameras, which are currently being incorporated into new ship designs, provide the basis for the VS project. Video Image Detection (VID) is a technology for the remote detection of events within the camera's field of view (FOV) by applying image analysis, or machine vision, techniques to the video image. Optical sensor systems sensitive to radiation outside the visible spectrum and acoustic sensors have been developed in combination with the VID technologies to produce an overall sensor system that is able to provide a broad range of situational awareness for the sensor's entire field of view. The use of remote sensing techniques removes the drawback of typical smoke and fire detection systems that rely on the diffusion of gases, particles, or heat to the detector.

A Volume Sensor Prototype (VSP) was developed at NRL to provide an affordable, real-time, robust, and remote detection sensor system that provides detection and classification of DC conditions such as fire, explosions, pipe ruptures, and compartment flooding. The VSP generates alarm notifications for action by the Damage Control Assistant and other available damage control systems based on the detected event.

3. Additional Information

This document focuses on the installation and operation of the CDP. The details of how the system's hardware, software, and algorithms were designed and work are not provided here. Details on the 2005 testing of the VSP on the *ex-USS Shadwell* are available in References 1 and 2, and the references within. The design and performance of the VSP as a whole is discussed in Reference 3 and the references within. Further details about the VS Long-Wavelength Video Detection (LWVD) Component specifically are available in References 4 - 6. Further details about the VS Spectral-Based Volume Sensor (SBVS) Component specifically are available in References 6 and 7. Further details regarding the VS ACST Component can be found in Reference 8. The *SigniFire* system is a COTS system from axonX Fike. Documentation on the *SigniFire* hardware and software can be found in References 17,18,20.

4. System Description

This section gives a brief overview of the CDP system. First, a brief overview of the CDP system as a whole is given. Next, a description of the CDP Sensor Head and internal components, as repackaged from the NRL VSP, is given.

4.1. System Overview

The CDP is a single-compartment configuration of the NRL VSP. The CDP is comprised of a collection of hardware components and software applications. The CDP is composed of the following components:

- Sensor elements for data acquisition
 - CDP Sensor Heads
 - IP cameras
- Auxiliary data acquisition modules
 - SBVS Fieldpoint Unit
 - Phantom power for the audio microphones
 - *SigniFire* network video recorder and data bridge
- Communications equipment
 - Ethernet network switch
 - Cabling
- Operator computer for
 - Data collection
 - Data analysis
 - Data fusion
 - Operator interaction and situational awareness

These elements and the physical connections between the elements are shown schematically in Figure 4-1. Section 5 discusses the installation of the CDP.

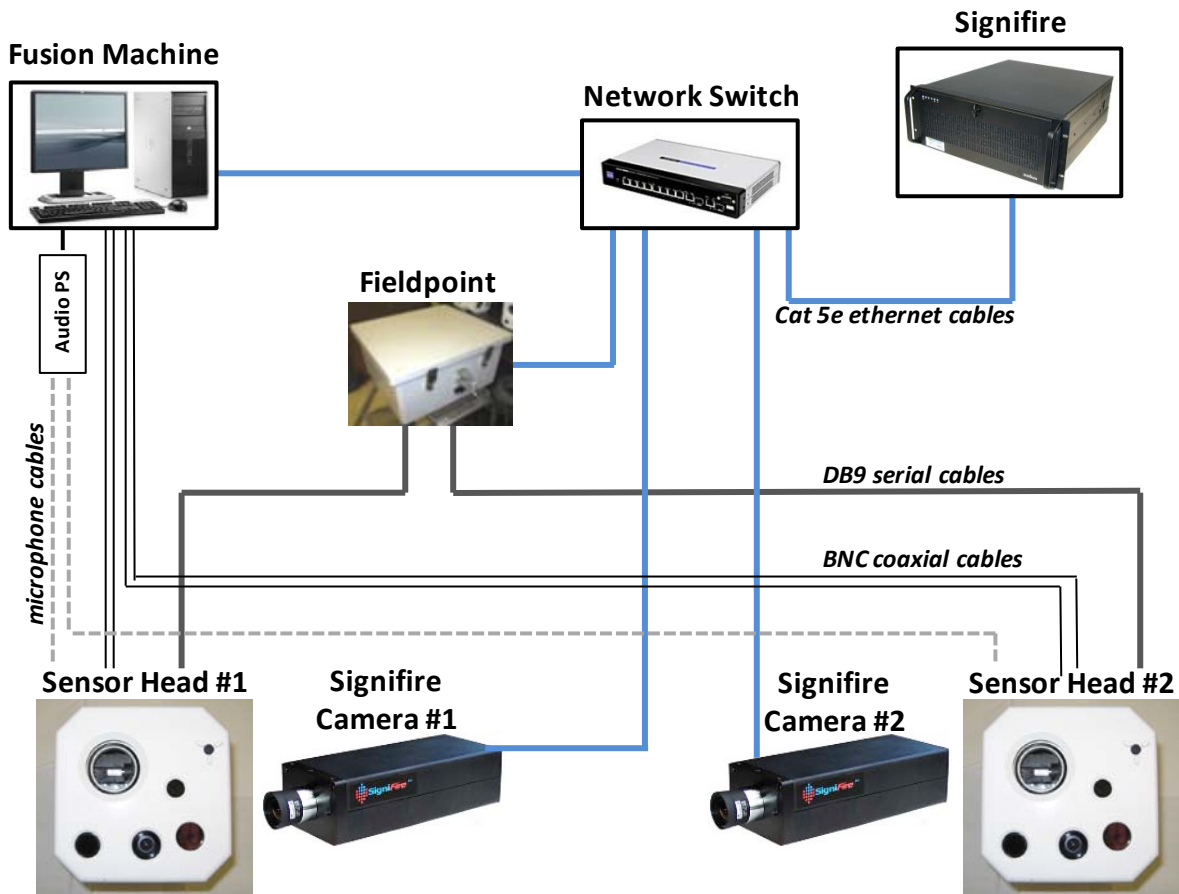

Figure 4-1 – Volume Sensor Demonstrator Prototype Components and Connections

4.2. Canadian Demonstrator Prototype Sensor Head

The CDP sensor heads were fabricated by Vibro-Meter, Inc. (VMI), and contain six individual sensor elements. Two video cameras are included, one color CCTV camera, and one long-pass (NIR) filtered black and white CCTV camera. An audio microphone is included. Finally, three of the non-imaging SBVS sensor elements are included, the mid-IR ($4.3 \mu\text{m}$), the UV, and the NIR (1050 nm) sensors. The visible (590 & 766 nm) sensors of the original SBVS Component Prototype were not included after a cost/benefit analysis was conducted and indicated that they could be excluded with little or no impact on performance [7]. The CDP sensor head is shown in Figure 4-2.



Figure 4-2 – Front View of the Canadian Demonstrator Prototype Sensor Head

Power is provided to the CDP sensor head and the outputs from the SBVS sensor elements in the sensor head are accessed via a screw-terminal connector on the backplane of the sensor circuitry as shown in Figure 4-3. The pinout of this connector is provided in Table 4-1. Three 4-conductor cables are used to connect the input power to the units and to bring the sensor outputs outside the sensor head. One wire is used for power and the remaining two are used to carry the three signal outputs. The three sensor outputs are combined on a single DB-9 connector for connection to the data acquisition electronics. The pinout information for this connector is also provided in Table 4-1.



Figure 4-3 – Internal View of the Canadian Demonstrator Prototype Sensor Head

Table 4-1 – Wiring Connection Pinout for CDP Sensor Head

Connection	Terminal Block Pin	Wire Color / Cable Number	cFP DB-9 Input Pin
IR Signal	4	Red / 1	1
IR Ground	10	Green / 1	6
NIR Signal	2	Black / 1	3
NIR Ground	10	White / 1	7
UV Signal	7	Black / 2	5
UV Ground	10	White / 2	9
Power (+24 VDC)	8	Red or Black / 3	N/A
Power Ground	11	Green or White / 3	N/A

The output from each video camera is standard, RS-170 analog video which is presented on a 75 Ω , BNC coaxial connectors (receptacle). The microphone output cable is terminated with a mini XLR connector. The microphone requires external phantom power to operate, as discussed in Sections 5.5 and 9.

5. System Installation

This section describes the installation and initial setup of the CDP. Figure 5-1 shows the physical components and connections of the prototype. These are:

- Sensor heads and IP cameras for data acquisition
- Optical sensor remote data acquisition module (Fieldpoint) for digitizing the optical sensor outputs
- Phantom power for the audio microphones
- Network switch to provide a common network interface to the various components
- *SigniFire IP* camera interface computer to provide a data bridge from the *SigniFire* cameras to the CDP Fusion Machine
- CDP Fusion Machine computer for processing the non-*SigniFire* data, performing data fusion, displaying alarms and situational awareness, recording sensor head video, and providing the user interface for system command and control
- Cable pathways

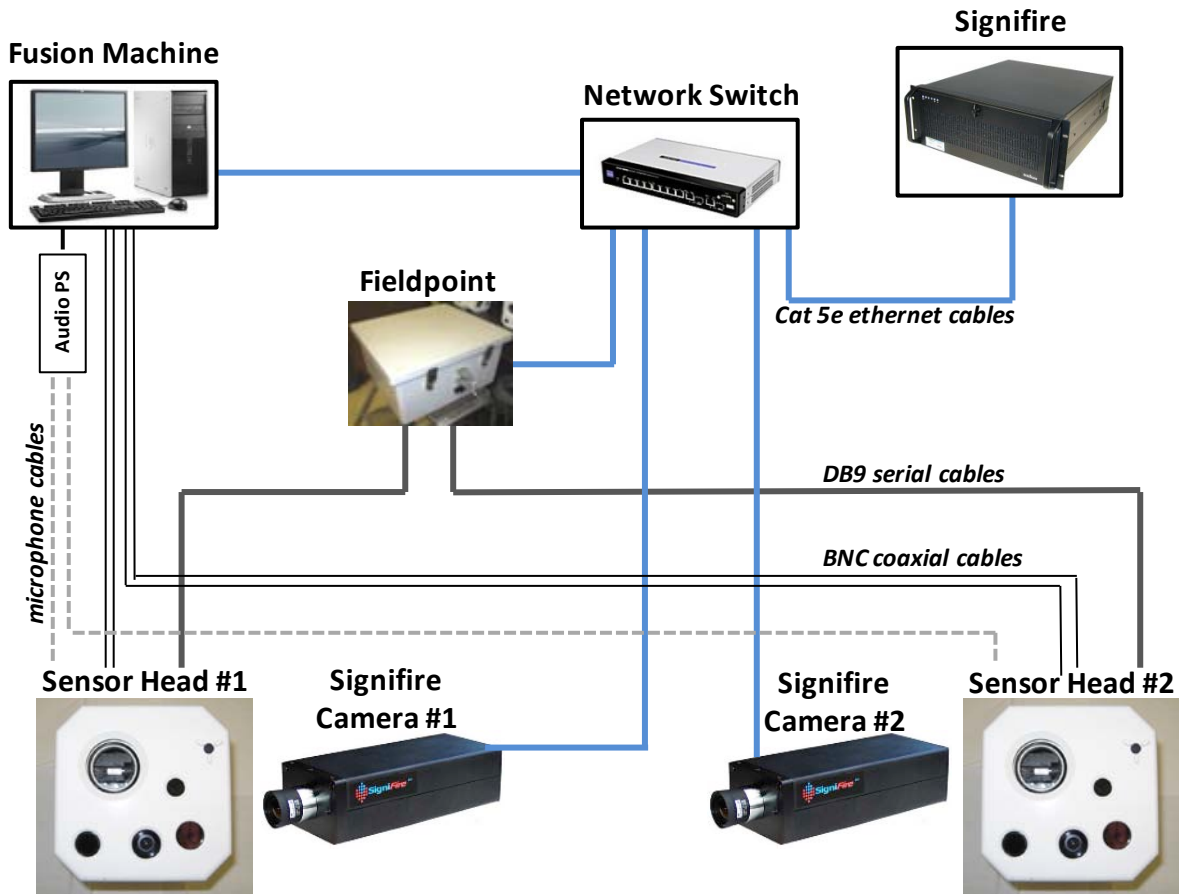

Figure 5-1 – Volume Sensor Demonstrator Prototype Components and Connections

To install the CDP system, the following steps are required.

- Identify appropriate locations for:
 - CDP Sensor Heads
 - Machine vision cameras
 - Computers
 - Auxiliary data acquisition elements
 - Cabling
- Mount sensor elements
- Setup computers and auxiliary data acquisition elements
- Connect cabling

The remainder of this section details the installation of the CDP system. Section 6 details the proper procedure for powering up the CDP and the subsystem components.

5.1. Sensor Location

Figure 5-1 shows the individual components and system interconnections (cables) of the installation of the CDP. Given the standalone nature of the CDP design, it is anticipated that the Fusion Machine computer, *SigniFire* NVR computer, the SBVS Fieldpoint unit, and the network switch would be collocated in a small workstation such as table positioned outside the test compartment and isolated from where damage control testing actually occurs. The cable bundles supplied to connect the sensors with the computers are all 50 feet in length, the nominal cable length limit for the components that output analog signals.

NOTE: The system configuration of the NRL VSP in Reference 2 and similar references was implemented to be installed in multiple compartments with command and control and DC personnel to be situated at remote locations. While the CDP was designed to function as a stand-alone unit, none of the installation flexibility of the NRL VSP was compromised. Contact NRL to discuss the infrastructure required for a distributed installation. Investment in a significant amount of hardware would be required.

The CDP sensor heads and *SigniFire IP* cameras are expected to be mounted on the walls of the test compartment with the provided camera-style mounts. An example installation from the recent shakedown testing of the CDP on the *ex-USS Shadwell* [9] is shown in Figure 5-2.

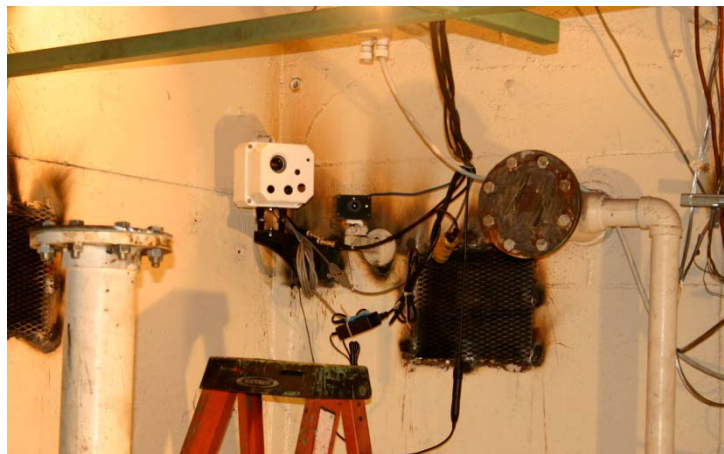

Figure 5-2 – Typical installation of a CDP Sensor Suite

The location of the sensors in the test compartment is at the discretion of the test director, but the recommended locations for maximum coverage and effectiveness are close to the compartment ceiling on opposing walls or corners. Care should be taken to maximize coverage of the test compartment with overlapping sensor fields of view. Smoke tends to rise, so the inclusion of the ceiling of the compartment in the FOV should be favored over that of the floor. Lighting and compartment illumination are also important factors to consider. Diffuse lighting such as fluorescent or other covered illumination sources are recommended over bare halogen lights,

which generate a much more intense and broad spectrum of radiation, or bare filament-based lighting. As an example, the sensor layout for the recent shakedown testing of the CDP on the *ex-USS Shadwell* is shown in Figure 5-3.

NOTE: If un-diffused halogen lights are installed, they should not be positioned such that they can directly or indirectly (reflections) illuminate the sensor heads or cameras. The intense output from these light sources deviate strongly from the typical design background radiation levels for Volume Sensor components and will cause the Volume Sensor to perform less efficiently.

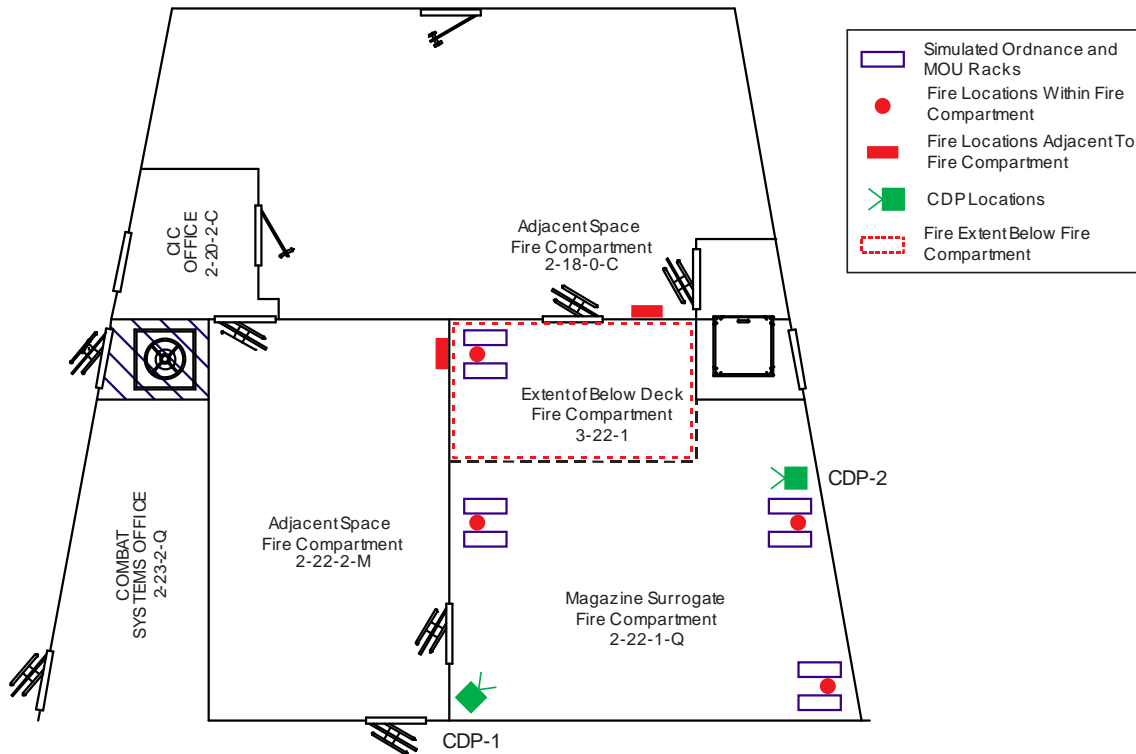

Figure 5-3 – Volume Sensor Placement During CDP Shakedown Testing

5.2. Sensors

The CDP is designed to operate with two sensor suite positions, each sensor suite position comprised of a CDP sensor head and a *SigniFire IP* camera. A CDP sensor head unit is shown in Figure 5-4 with each of the six sensor elements labeled. A third CDP sensor head has been supplied as a spare unit. The mounts (Videoalarm P/N WM800) for the sensor head units are shown in Figure 5-5 (a). Mounting bolts are supplied with the mounts to attach the CDP sensor head to the mount via tapped holes on the bottom of the CDP sensor head. Bolts or other sturdy fasteners may be used to attach the mounts to the walls.

NOTE: Each CDP sensor head weighs in excess of 12 pounds. The Videoalarm mounts are sized accordingly. Any wall mount must also be appropriately sized.

The *SigniFire IP* camera is shown in Figure 5-6. Two *SigniFire IP* cameras are supplied with the CDP. Spares can be obtained from the manufacturer, axonX Fike. The mounts for cameras are shown in Figure 5-5 (b). The mounts (Videoalarm P/N CWPM8) contain a thumb screw which attaches to the mounting hole located on the bottom of the camera unit. Screws or other suitable fasteners should be used to attach the camera mounts to the wall.

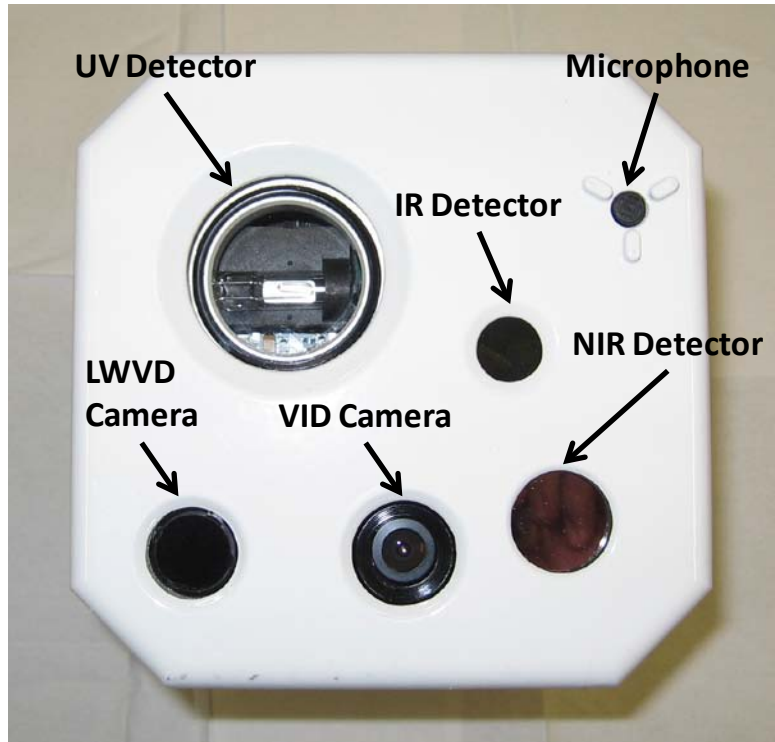

Figure 5-4 – Sensor head unit with labeled sensing components



b)

Figure 5-5 – (a) Sensor head mount, (b) *SigniFire IP* Camera mount

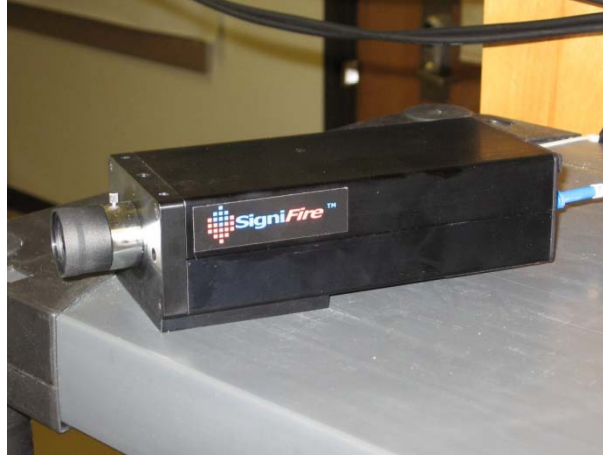

Figure 5-6 – *SigniFire IP* machine vision camera

The combination of a CDP sensor head, or white box, and a *SigniFire IP* camera is referred to as a Sensor Suite (SS). The CDP is designed to process the incoming data from two sensor suites, numbered SS #1 and SS #2. Table 5-1 lists the serial numbers of the CDP sensor heads and *SigniFire IP* cameras that are associated with the two sensor suites, as the CDP was configured at the time of delivery. It is important that the sensor elements be connected to the CDP as indicated in Table 5-1 in order to preserve the as-delivered calibration of the system. Sensor elements can be replaced as necessary, but the processes described in the later sections of this document must be followed for proper calibration.

Table 5-1 – Serial Numbers for CDP Sensor Suite Components

Sensor Suite	CDP Sensor Head	<i>SigniFire IP</i> Camera
SS #1	#001	#345
SS #2	#002	#394

All of the cables provided to connect the SS sensor components to the CDP are COTS and are readily available. Two pre-assembled cable sets are provided with the system, one for each sensor system. Some spares are provided with the CDP, but not assembled into cable sets. Both color coding and numbering are used to distinguish the various components, cables, and how to connect them. The individual cables in each cable set are labeled either #1 or #2 to distinguish which should be connected to or from SS #1 and SS #2, respectively. The connectors of cable set #2 that mate to the sensors are shown in Figure 5-7. Each cable bundle has five connectors, as labeled in the figure. Many of the connectors are symmetrical, with the exceptions of the data cable for the Optical sensors (a standard DB-9 serial cable) and the audio microphone cables. The cable bundle should be installed such that the DB-9 plug connector is available to connect to DB-9 socket connector located on the CDP sensor head.



Figure 5-7 – Cable set for sensor suite #2

DC power is provided to each CDP sensor head by the supplied power brick.

NOTE: DO NOT connect the sensor heads to their power bricks until all data connections are established and the demonstrator prototype is ready for power-on. The cameras may be damaged if they are connected or disconnected when the power is connected. Always disconnect the power to the sensor heads prior to connecting or disconnecting the BNC video cables. There are no LED or other indicators on the sensor heads to indicate when power is connected.

The *SigniFire IP* cameras are powered with the network cable by the power-over-ethernet (PoE) capability provided by the network switch. No other power supply is necessary for the *SigniFire IP* camera. An LED located on the front of the camera lens indicates that the camera is powered and the current camera status.

A summary of the color codes and numbering for the sensor cables is provided in Table 5-2, broken out by sensor suite. Several abbreviations are used in the table. In the Destination column, "FM" refers to the Fusion Machine computer, which is discussed in more detail below. As noted above, DO NOT connect the sensor heads to power until all cables connections are made.

At this point, the cable bundles should be connected to the sensor heads and *SigniFire IP* cameras. A small screwdriver can be used to tighten the connector screws of the DB-9 cables. The connection of the cable sets to their respective destinations should be left to the subsystem installations described below.

NOTE: The CDP sensor heads are prototype units and as such, care should be taken with the handling of the units, particularly the cable set that extends from the rear of the CDP sensor head. Proper strain relief of the cables to prevent damage to the cables and the internal components of the CDP sensor heads is required. The connection of these cables to the internal components of the CDP is shown in Figure 4-3 for reference.

Table 5-2 – Numbers and color codes for sensor cables

SS #1				
Sensor(s)	Cable Type	Color	Number	Destination
UV, IR, NIR spectral	DB-9 serial	blue	#1	Fieldpoint/#1
LWVD camera	BNC coax	gray	#1	FM/Video #1
VID camera	BNC coax	purple	#1	FM/Video #2
microphone	microphone	white/yellow stripe	#1	Stewart/Input #1
power	DC plug	yellow	#1	power brick
IP camera (#345)	Cat 5e ethernet	green	#1	network switch
SS #2				
Sensor(s)	Cable Type	Color	Number	Destination
UV, IR, NIR spectral	DB-9 serial	blue	#2	Fieldpoint/#2
LWVD camera	BNC coax	gray	#2	FM/Video #3
VID camera	BNC coax	purple	#2	FM/Video #4
microphone	microphone	white/blue stripe	#2	Stewart/Input #2
power	DC plug	yellow	#2	power brick
IP camera (#394)	Cat 5e ethernet	green	#2	network switch

5.3. Computers

Two computers are included as part of the CDP. The Fusion Machine is responsible for processing the data from the optical sensors, microphones, and sensor head video streams, performing data fusion, recording video, and providing the human interface to the demonstrator prototype. The computer employed as the Fusion Machine is the Hewlett-Packard (HP) Z400 computer. The *SigniFire IP* cameras are controlled and interfaced with via the *SigniFire* Network Video Recorder (NVR).

The Fusion Machine computer is the primary core of the CDP. Figure 5-8 shows the backplane of the Fusion Machine computer with the locations for the keyboard, mouse, and graphics card connectors identified. The connectors for the network, video, and audio subsystems are also shown. In order to accommodate cable lengths, the Fusion Machine should be located within 50 feet of the sensor heads. A keyboard, mouse, and LCD monitor are included, as are power cables for the computer and monitor. The supplied DisplayPort-to-DVI adapter should be used to connect the graphics card on the rear of the computer, as shown in Figure 5-8, to the LCD monitor with one of the supplied DVI-to-DVI cables.

At this point, the color-coded BNC coaxial cables in the cable bundles from sensor suites #1 and #2 should be connected to the Fusion Machine computer. The labels "Video1", "Video2", "Video3", and "Video4", shown Figure 5-8, correspond to the Fusion Machine destinations listed in Table 5-2 for the sensor head LWVD and VID cameras. For additional clarity, the labels "1" and "2" indicate the sensor suite number, while the colors "gray" for LWVD and "purple" for VID distinguish where each BNC coaxial cable is connected.

NOTE: The coaxial video cables supplied are constructed from RG-59A cable and designed for 75 Ohm termination, as is standard for video applications. Standard laboratory BNC cables are typically built from RG-58 cable and designed for 50 Ohm termination. The use of 50 Ohm cables will degrade performance and should be avoided.

NOTE: The use of tools such as pliers to make or break the coaxial cable connections is not recommended and should be avoided. Cable damage will result.

NOTE: A fifth, white BNC connector is available on the Fusion Machine located near the video input connectors. The connector is taped off and unlabeled. This connector is not used by the CDP and no connection should be made to it.

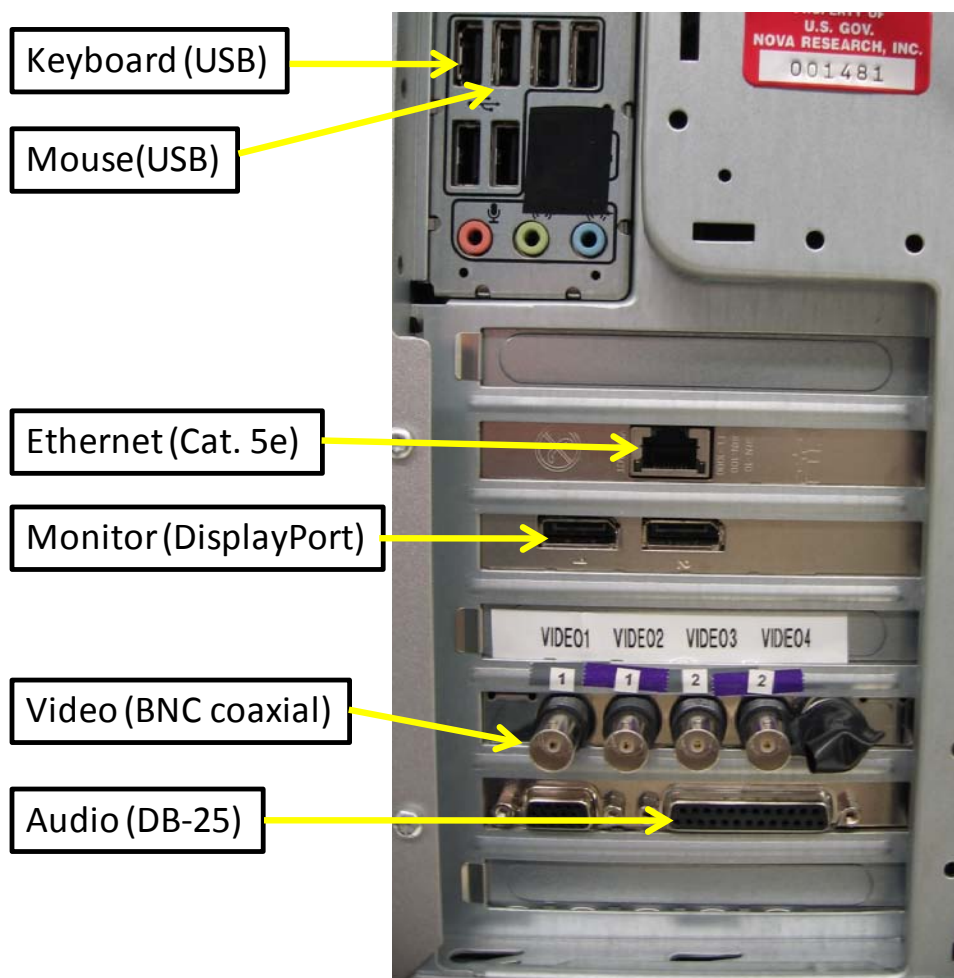

Figure 5-8 – Fusion Machine computer backplane indicating connectors for keyboard, mouse, monitor, and the network, video, and audio subsystems

5.4. Optical Subsystem

The Optical Subsystem (the SBVS Component in VSP terminology) is responsible for the acquisition and digitization of data from the UV, IR, and NIR optical sensors. A remote data acquisition module, termed the Fieldpoint Unit after the core component, a National Instruments Compact Fieldpoint controller, samples and digitizes the analog outputs from the optical sensors in each CDP head. The Fieldpoint Unit is shown in Figure 5-9. Together, the optical sensors in the CDP sensor head, the Fieldpoint Unit, and associated analysis software running on the Fusion Machine computer comprise the SBVS Component for the CDP. The SBVS component is discussed in more detail in Section 7.

The Fieldpoint Unit is powered by US-standard 120 VAC, 60 Hz power. A standard three-prong power cable is supplied. The power switch located directly beneath the power cable (as shown in Figure 5-9 (a)), controls whether or not the unit is powered and an LED indicator is provided

for verification that the unit is powered on. A Category 5e ethernet cable should be used to connect the Fieldpoint Unit to the network switch, as discussed below.

Three DB-9 connectors are provided for connecting the DB-9 cables in each of the cable sets, in turn from each CDP sensor head. The connectors on the Fieldpoint Unit are labeled #1 and #2 to indicate the sensor suite number. The Fieldpoint Unit should be powered off when making or breaking cable connections. A small screwdriver can be used to tighten the connector screws.

NOTE: The CDP, as delivered, is not configured to make use of the third connector on the Fieldpoint Unit, Sensor Suite #3, however the unit is fully populated for potential later use. Contact NRL to discuss the requirements involved to make use of this capability.

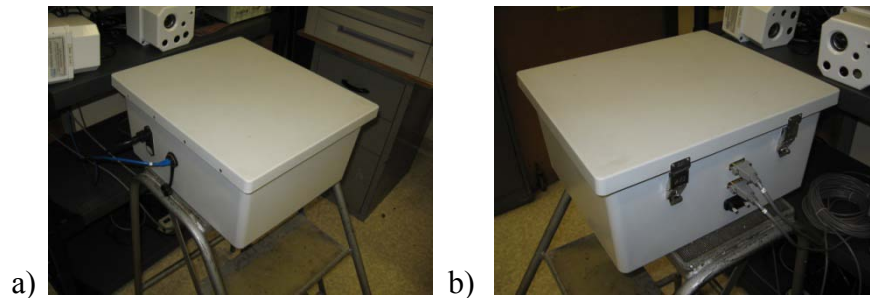

Figure 5-9 – Fieldpoint Unit, (a) power and network, (b) serial data connections

5.5. Audio Subsystem

The audio subsystem of the CDP is responsible the collection and processing of the audio signals generated by the microphones in the CDP sensor heads. As is typical for most microphones, the microphones require external power to function. This power source is termed Phantom Power in the audio industry, and a phantom power supply (Stewart Audio) is included with the CDP. The microphones, phantom power supply, audio breakout cable, digital audio card, and analysis software comprise the acoustics (ACST) sensing system of the CDP. The ACST system is discussed in more detail in Section 9.

To physically connect the hardware components of the ACST subsystem, the following steps are required.

The microphone cable from the cable set from each of the sensor heads should be connected to the appropriate input of the phantom power supply, as shown schematically in Figure 5-10. The microphone connector with the yellow stripe from SS #1 should be connected to "Input #1", the connector with the blue stripe from SS #2 to "Input #2".

The audio card break-out cable should be connected to the audio card in the Fusion Machine computer via the DB-25 connectors, as shown in Figure 5-8. Only two of the microphone

connectors on the break-out cable are used in the CDP. These are the white connector labeled "In #1" and the red connector labeled "In #2". The other connectors on the break-out cable have been taped off and are currently not used. White In #1 should be connected to "Output #1" on the phantom power supply, and red #2 to "Output #2". The labels "Sensor #1" and "Sensor #2" on the phantom supply indicate the correct signal pathway. The phantom power supply comes with a DC power supply marked with orange tape. Once all data cable connections are made, the ¼-in male power plug, also marked with orange, should be inserted into the ¼-in female plug marked in orange on the phantom power supply. There are no indicator lights on the phantom power supply.

When all connections are complete, the connections to the phantom power supply should resemble those shown in Figure 5-11.

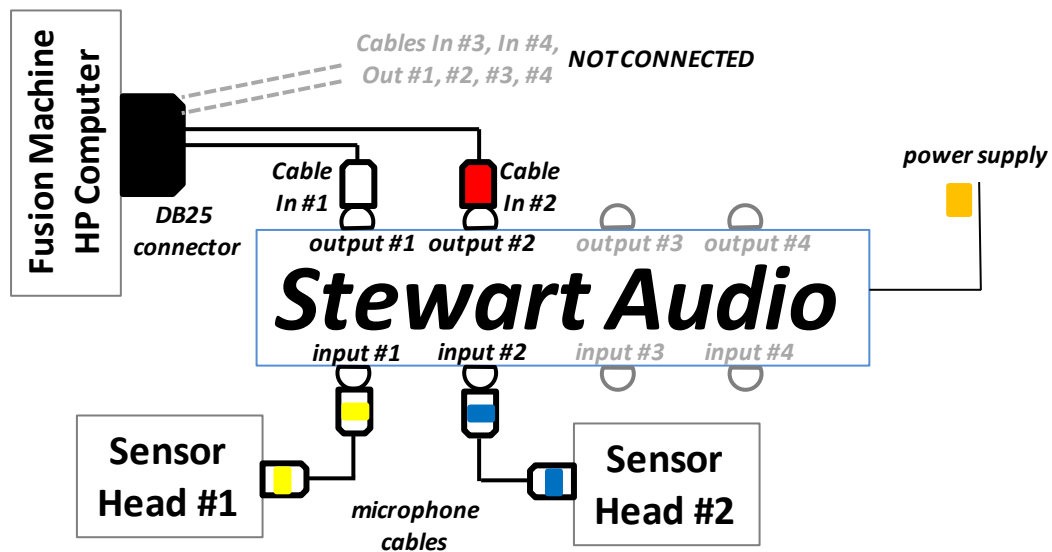

Figure 5-10 – Schematic View of the Audio Subsystem Components and Connections



Figure 5-11 – Connections to Phantom Power Supply

NOTE: The CDP, as delivered, is configured to only make use of two microphone inputs. The unit is populated to handle up to four microphones total for potential future use. Contact NRL to discuss the requirements involved to make use of this capability.

5.6. SigniFire - Machine Vision Subsystem

The machine vision subsystem of the CDP provides the interface to algorithm outputs of the *SigniFire IP* cameras and consists of the *SigniFire* NVR computer (including a monitor, a keyboard, and a mouse). The machine vision algorithms and processing are performed in hardware embedded in the camera itself. Software on the *SigniFire* NVR computer serves as the human interface for the *SigniFire IP* cameras, archives the video output and alarm states from the cameras in a proprietary format in a circular buffer, and provides the interface between the *SigniFire IP* camera and the data fusion algorithms running on the Fusion Machine computer.

The setup of the *SigniFire* system is straightforward. A Category 5e ethernet cable should be used to connect the *SigniFire* NVR computer to the network switch, as discussed below. The launching and operation of the *SigniFire* server software is discussed in Section 6.2.

NOTE: The *SigniFire IP* cameras are provided with adjustable focus lenses. The quality of the image for each camera should be verified during installation. This can be done using the *SigniFire* NVR software's camera browser or by connecting a service monitor to the output BNC on the back of the camera.

5.7. Network Subsystem

The network subsystem of the CDP consists of the provided network switch, the power supply, and the associated Category 5e Ethernet cables. The components and connections of the network

subsystem are shown in Figure 5-12. The CDP is designed to use a non-routing, internal, (i.e., 192.168.0.xxx), ethernet-based network for communications between the various VS components. Network capabilities are provided by the switch, which should be located near the Fusion Machine.

The red-labeled power connector and power brick should be used to power the network switch. The unbundled, blue Category 5e ethernet cables should be used to connect the Fusion Machine computer, the *SigniFire* computer, and the Fieldpoint unit to the network switch, as shown in Figure 5-1. In addition, the blue Category 5e ethernet cables in the sensor head cable bundles should be used to connect the two *SigniFire* cameras to the green-labeled ports on the ethernet switch, as shown in Figure 5-12.

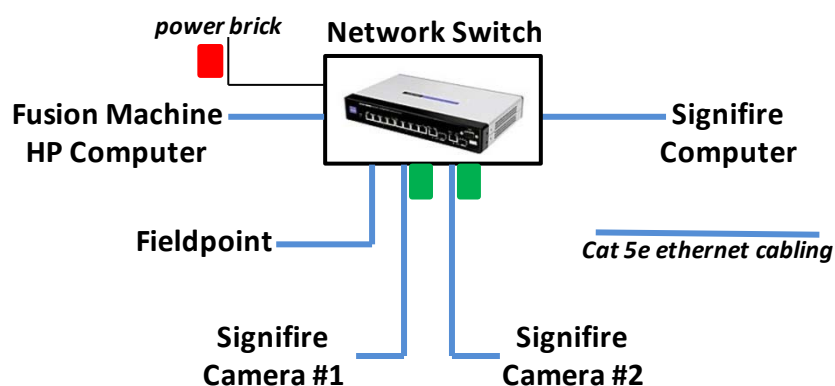

Figure 5-12 – Network subsystem components and cabling

NOTE: The CDP, as delivered, is configured to run on the non-routing 192.168.0.XXX subnet. If desired, it is possible to reconfigure the system to run mostly on a live Ethernet network. Contact NRL to discuss the requirements involved to migrate to a live Ethernet network.

6. System Operation

This section describes the proper procedure for powering up the CDP and how to operate the included software. The first two sections outline the proper procedure for powering on the various hardware components, and then how to launch the software components and the graphical user interface (GUI). A brief checklist of system diagnostics is reviewed next to ensure that all subsystems are functioning properly. The recommended method for conducting a demonstration test with the CDP is reviewed next. Then the situational awareness provided by VS on the GUI is described. Finally, the data logging and video recording capabilities are documented.

6.1. Power-on Procedure

The components of the CDP should be powered up in the following sequence:

1. The CDP sensor heads should be powered on by connecting the CDP sensor head power cable to the provided power supplies. The CDP sensor head power cables and power supplies all have yellow labels.
2. The network switch should be powered on. Power is applied by connecting the unit's power supply to the switch. Several of the LEDs on the switch display will illuminate to indicate proper operation. All power cables are marked with red labels.
3. The Fieldpoint Unit should be powered on. The unit is powered by the switch on the exterior. There is a green power LED to indicate a good power supply.
4. The microphone phantom power supply should be powered on. The power supply is labeled in orange.
5. The *SigniFire* computer and monitor should be powered on. Press the ON switch on the front panel to turn the computer on.
6. The Fusion Machine computer and monitor should be powered on. Press the ON switch on the front panel to turn the computer on.

It may be convenient to use a properly-rated, multiple-outlet power strip and possibly extension power cords to supply power to the CDP sensor heads from a common point with a single ON/OFF switch. Similarly, a properly-rated, multiple-outlet power strip can be used to distribute power to all of the remaining components.

NOTE: The IR sensor supplied in the CDP sensor heads requires a minimum of 60 minutes and preferably 120 minutes to thermally stabilize. If the testing schedule does not allow for sufficient warm up time each day, it is recommended that sensor heads be left powered for the duration of testing. The CDP sensor heads should not be left powered indefinitely as this will limit the life span of the included cameras.

6.2. Software Launch

The launching of the software components is divided into three steps. First, the software programs that perform the analysis of sensor data which run on the Fusion Machine computer are started. Second, the software that provides the link between the *SigniFire IP* cameras and the data fusion applications is launched on the *SigniFire* computer. Third, the software programs that perform data fusion and provide situational awareness on the Fusion Machine are started. A

two-step launch procedure is used on the Fusion Machine in order to allow the operator an opportunity to verify that all sensor systems are functioning properly before initiating the data fusion processing and graphical user interface.

The following assumes that both the Fusion Machine and *SigniFire* computers have started properly. The Fusion Machine computer will automatically log the user in and arrive at the desktop on startup¹. To launch the sensor-component level analysis software, the operator should double-click on the desktop icon labeled “Volume Sensor Component Launcher”, as shown in Figure 6-1. The script file represented by this icon launches the following seven applications:

1. Optical (SBVS) for SS#1
2. Optical (SBVS) for SS#2
3. Acoustics for SS#1 and #2
4. LWVD Machine Vision for SS #1
5. LWVD Machine Vision for SS #2
6. CCTV recording for SS #1
7. CCTV recording for SS #1

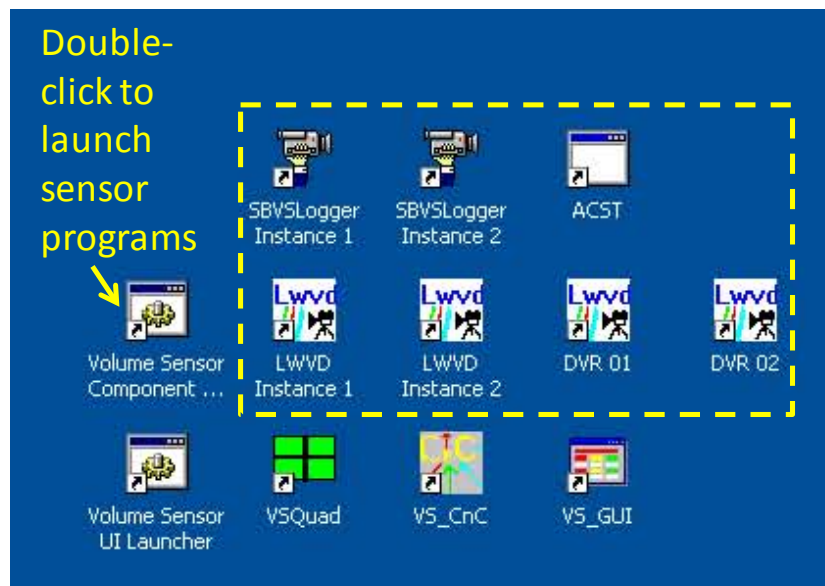

Figure 6-1 – Fusion Machine desktop icons for sensor programs

As indicated in Figure 6-1, it is possible, but not recommended, to launch each piece of component analysis software with the seven icons boxed by a dashed line.

¹ The implied user name for this system is: VolumeSensor and the login password is: volumeNRL6100. In case the operator forgets the login password, the password hint feature contains the same information. This is one issue to be addressed if the system is to be placed on a live Ethernet network.

The second step is to launch and configure the applications on the *SigniFire* computer that are necessary for the *SigniFire IP* cameras to communicate with the CDP data fusion algorithms. The *SigniFire* computer will present a Windows login screen to the operator. The operator should select the *SigniFire* user to login². Briefly, to start up the system requires that two applications be started. First the *SpyderGuard IP* application is launched using the previously stored configuration. The configuration file (`NRL 2 Channels.axf`) is located on the NVR desktop, as shown in Figure 6-2. Double-click on the configuration file to launch *SpyderGuard IP*. Second, the `VSCS.Bridge` middleware application is launched using the icon on the NVR desktop, also shown in Figure 6-2. Once both systems have started correctly, the main screen of each application will resemble those shown in Figure 6-3 and Figure 6-4.

NOTE: It is recommended that once set up for a demonstration series that the *SigniFire* NVR not be power cycled. Once installed and properly configured, the *SigniFire* system is designed for long term operation. If the NVR and *SigniFire* server software have been properly configured since the last power cycle, system startup is straightforward with no required configuration. If the system has been power cycled, the extended startup procedure described in Section 10.2 must be followed.

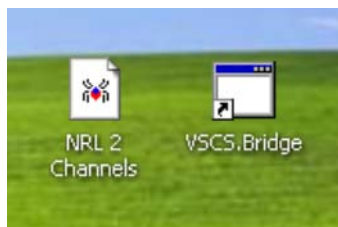

Figure 6-2 – *SigniFire* application desktop icons

² This system has no assigned login password. This is one issue to be addressed if the system is to be placed on a live Ethernet network.

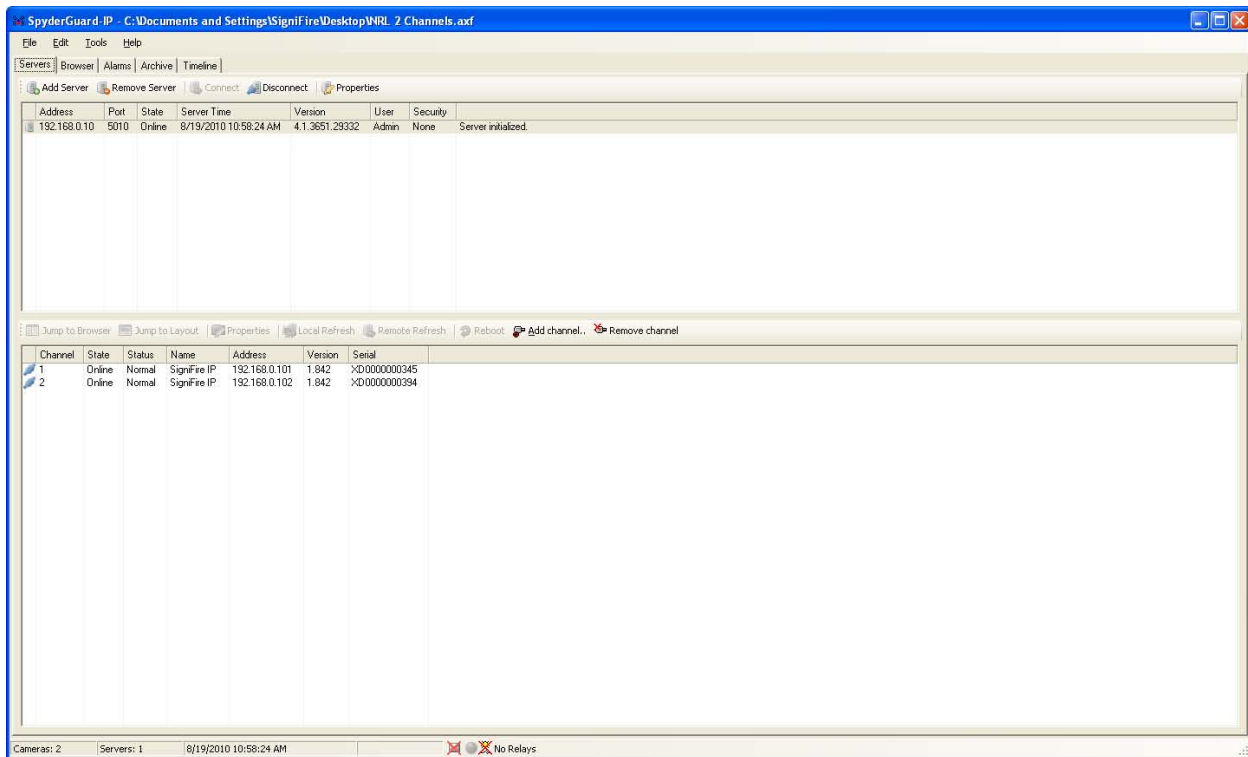

Figure 6-3 – *SpyderGuard IP*, Server Tab, with Cameras Loaded

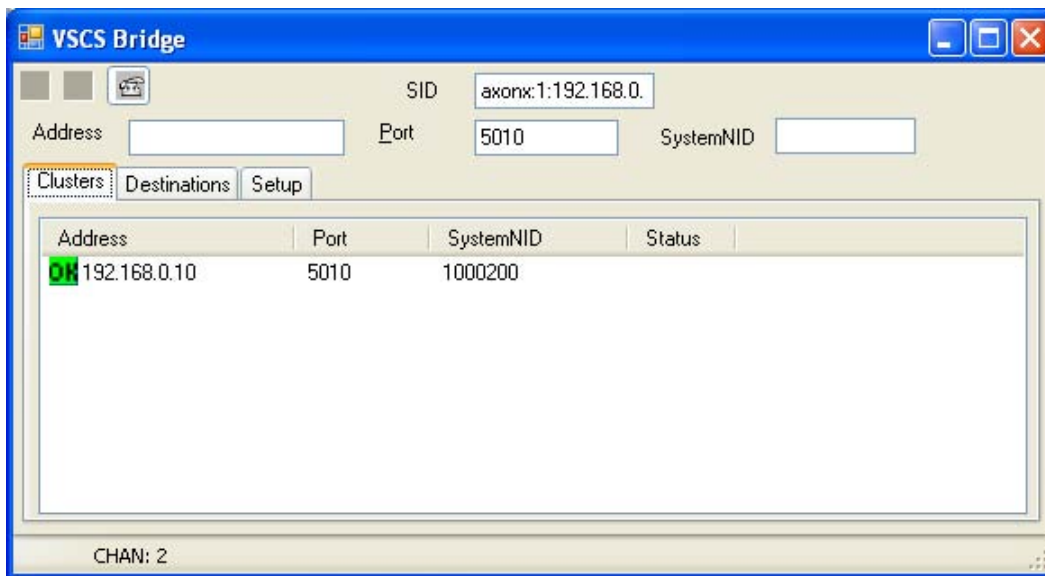

Figure 6-4 – VSCS.Bridge, Cluster Tab

6.3. Data Fusion and UI Software Launch

All component-level data analysis software is now running. It is now time to start the data fusion and UI elements of the CDP. Double-click on the “Volume Sensor UI Launcher” icon on the

Fusion Machine desktop, as shown in Figure 6-5. The script file represented by this icon launches the following three applications:

1. VS_CnC
2. VS_GUI
3. VS_Quad

The VS_CnC application is the core of the CDP Fusion Machine. Data flow to the VS_CnC from the individual component-level analysis applications, where they are stored. The system-wide data fusion, event detection, and situational awareness classification algorithms are housed in the VS_CnC application as well. State control for the sensor components is controlled by the VS_CnC. Further details on the VS_CnC application can be found in Section 12. The VS_GUI is the user interface where analysis results and situational awareness are presented to the operator. The operator uses the VS_GUI application to control the operation of the CDP. Further details on the VS_GUI application can be found in Section 13. The VS_Quad application provides an aggregated view of the camera output images from the cameras in the CDP sensor heads. This is provided to the operator for enhanced situational awareness. Further details on the VS_Quad application can be found in Section 11. A typical configuration of the operator screen for the CDP is shown in Figure 6-6. As indicated in Figure 6-5, it is possible, but not recommended, to launch each piece of data fusion and UI software individually with the three icons boxed by a dashed line.

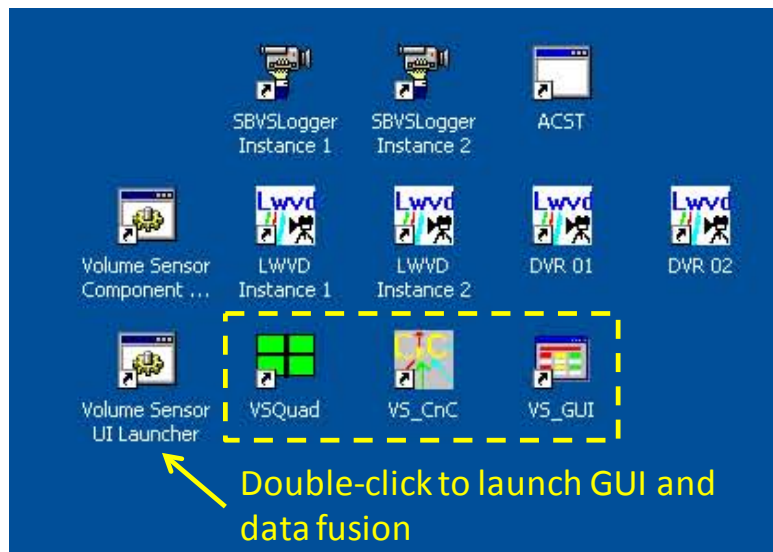

Figure 6-5 – Fusion Machine desktop icons for GUI and data fusion programs

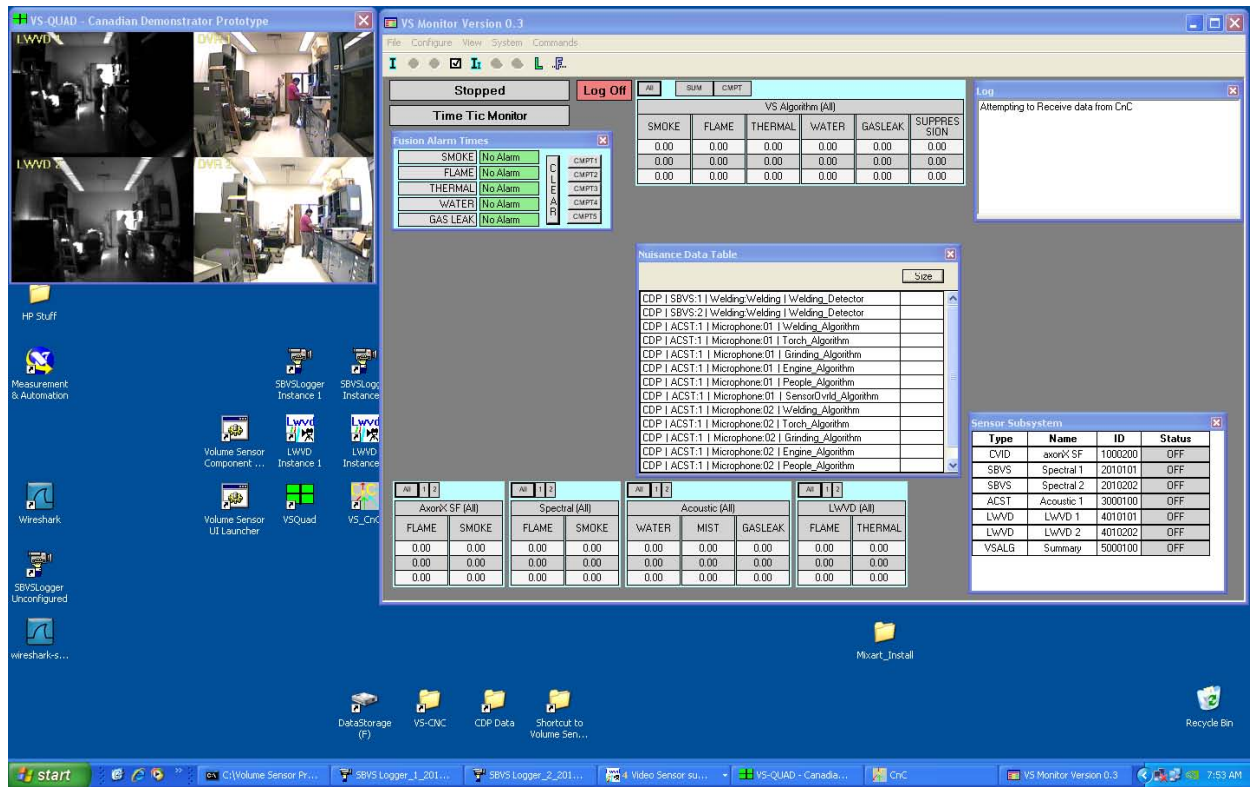

Figure 6-6 – Fusion Machine desktop, configured for CDP operation

6.4. Component System Verification Testing

With all of the CDP software and hardware running, it is prudent for the operator to ensure that all of the sensor component subsystems are operating nominally. A brief set of system checks is outlined below. Review of Sections 7 – 10 and the references within will provide further insight into the workings of each component system. These tests are best done with the individual components collecting data normally, such that all algorithms are functioning properly. To run the tests, the operator should start the system, as described in Section 6.5 and allow the system several minutes to establish a good background.

For the Acoustics subsystem (ACST), a simple check that the system is functioning is to make a loud sound, e.g. clapping one's hands. In Figure 6-7, the ACST application is shown running un-minimized. The response to hand clapping by the operator, a 30 dB amplitude increase, is highlighted in yellow.

For the Optical subsystem (SBVS), a good check is to hold a long-handled butane lighter in front of each sensor head and watch for both changes in all three signal levels (10500A, RefIR1, and UV_Count) as well as the EVENT and FIRE_FOV EVENT indications. The SBVSLogger application running normally is shown in Figure 6-8. The same screen is shown in Figure 6-9

while a butane lighter is being held in front of the CDP sensor head. The outputs of interest are highlighted in red.

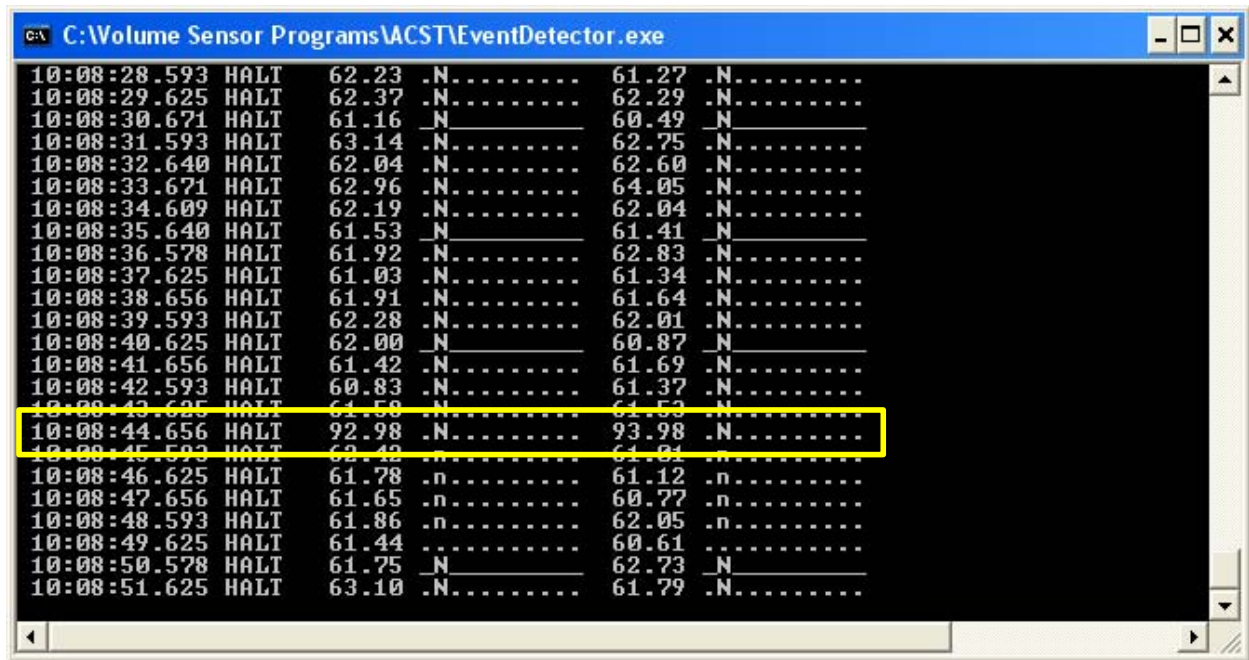

Figure 6-7 – ACST Subsystem Showing an Acoustic Event (Clapping of Hands)

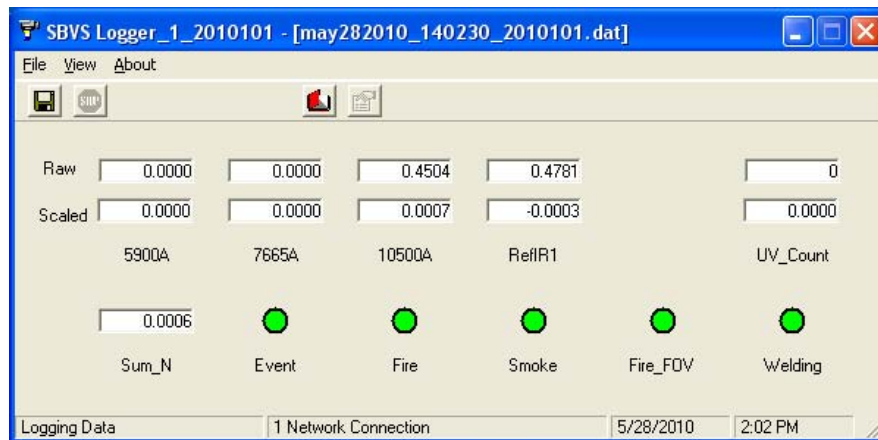

Figure 6-8 – SBVSLogger main screen, system processing incoming data

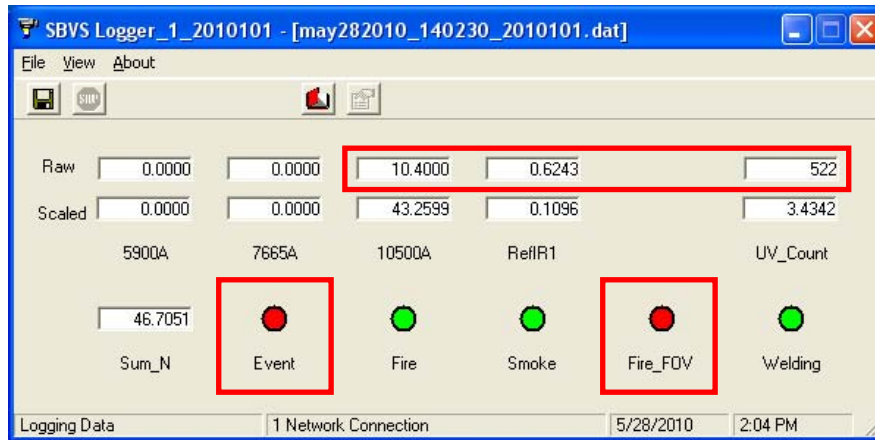

Figure 6-9 – SBVSLogger main screen, system detecting a FIRE_FOV EVENT

For both cameras in the CDP sensor head, there are two checks to perform. First, using the VS_Quad application, the image quality from each camera should be checked for picture quality. The LWVD camera image will be black and white, as is the camera, and mostly dark due to the longpass filter. The test lamp described in Section 7.6 or other light source (*e.g.* a flashlight) can be used to raise the image intensity for inspection. The CCTV cameras are color and unfiltered, so the image is readily inspected. A good example is shown in Figure 6-10. The second check is to ensure that the cameras are working and that the image displayed is live. Moving an object such as the test lamp in the view will verify this, as shown in Figure 6-11. This test should be used to verify operation of all instances of the LWVD application, both LWVD instances (LWVD 1 and LWVD 2) and both DVR instances (DVR 1 and DVR 2).

To further verify the operation of the Long-Wavelength Video Detection (LWVD) component subsystem, a test lamp such as the one described in Section 7.6 is used. The LWVD application is shown running in a normal state in Figure 6-12. The test lamp should be placed approximately 5 meters in front of each CDP sensor head, aimed directly at the sensor head and activated. As the persistence criteria in the LWVD's algorithm process the incoming data, the system state will change from normal to pre-alarm, as seen in Figure 6-13, and finally to alarm, as seen in Figure 6-14.

The *SigniFire IP* camera status and functionality is best checked using the *SpyderGuard IP* software on the *SigniFire* computer. The test lamp should be placed approximately 5 meters in front of each *SigniFire IP* camera, aimed directly at the camera and activated. The FLAME detection algorithm running in the *SigniFire IP* camera will change state from normal, as seen in Figure 6-15, to alarm, as seen in Figure 6-16. The detection is indicated in the *SpyderGuard IP* browser window as a red box.

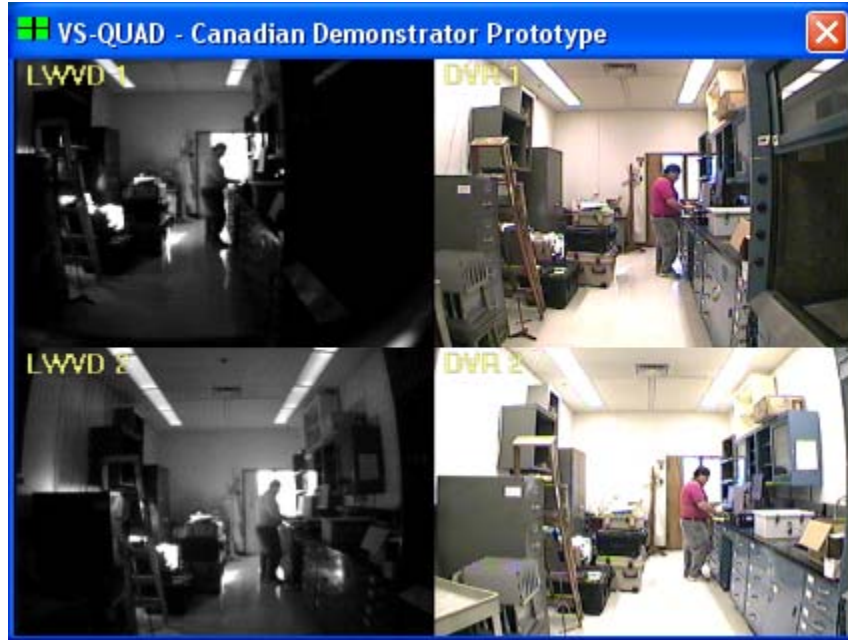

Figure 6-10 – Camera Image Quality Verification using VS_Quad Application

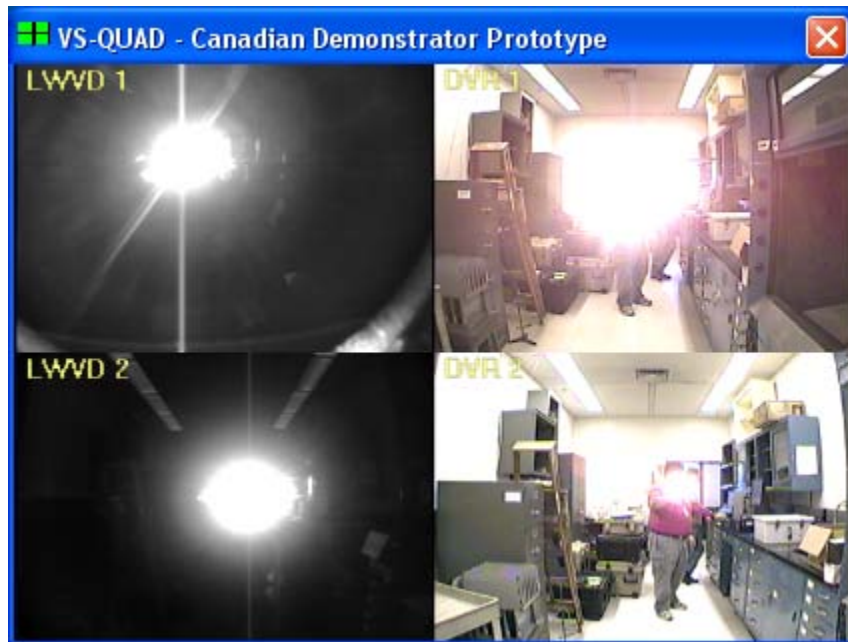

Figure 6-11 – Camera Status Verification using VS_Quad Application

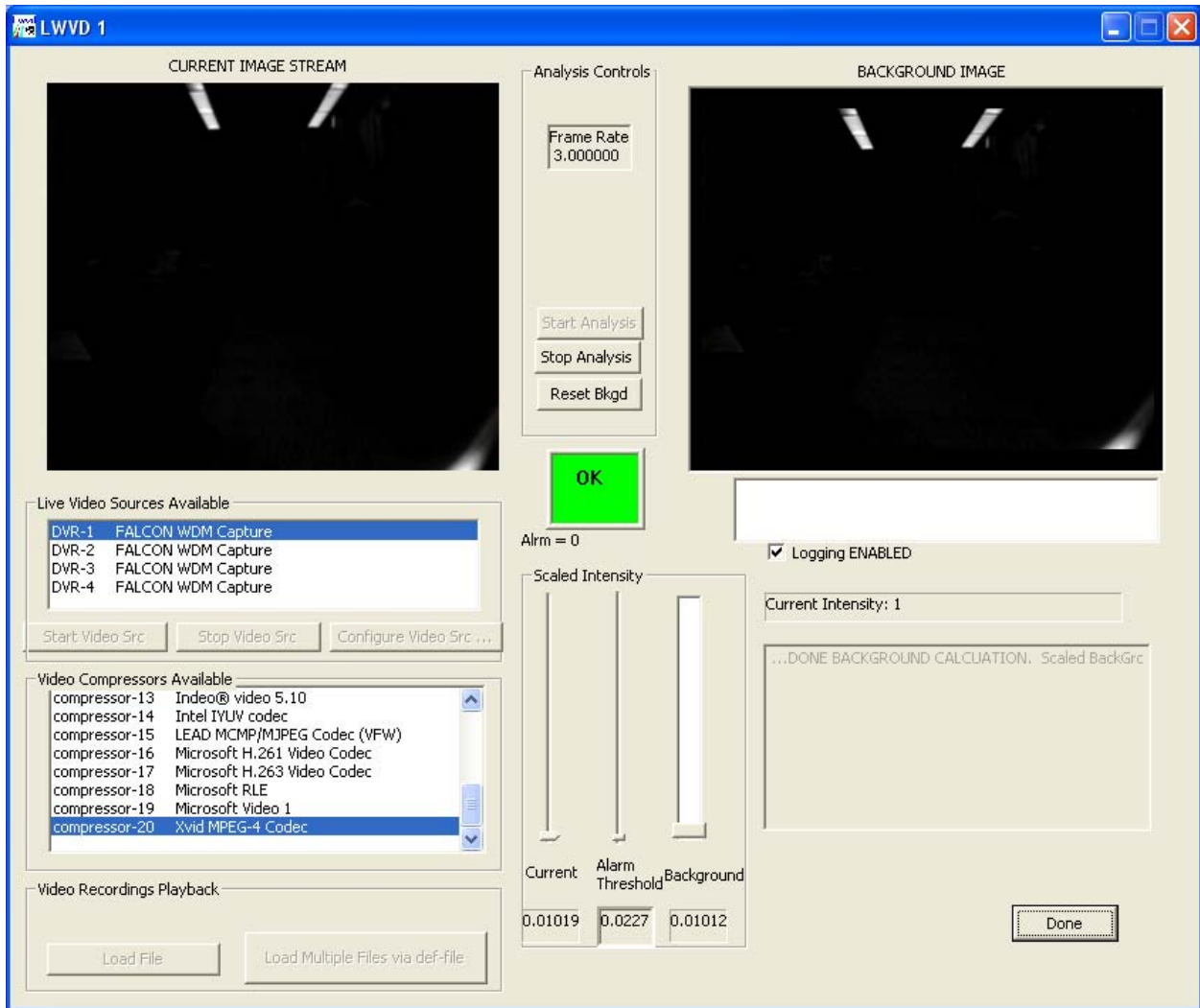

Figure 6-12 – LWVD main screen, system processing incoming data

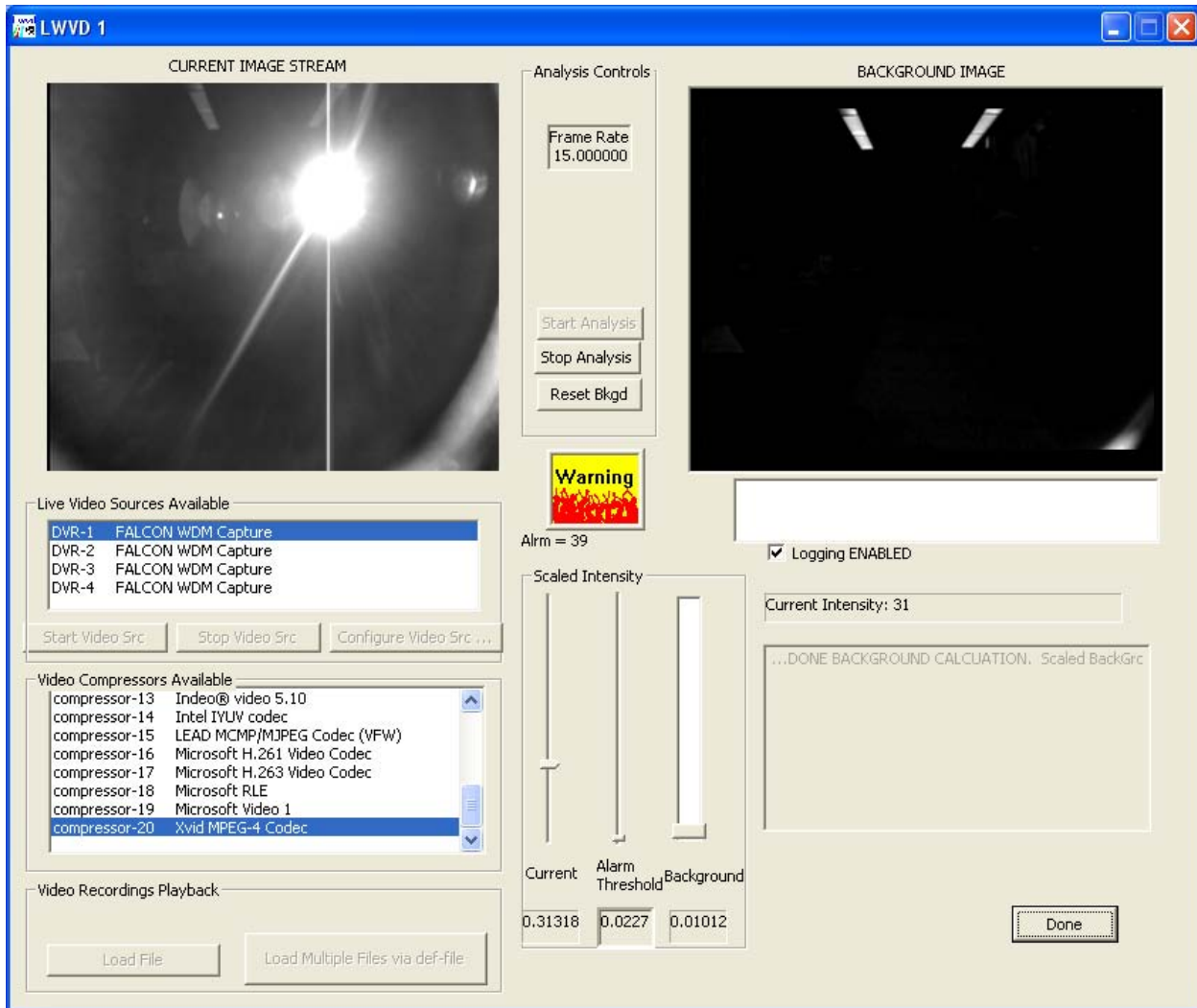

Figure 6-13 – LWVD main screen, system in FLAME pre-alarm state

NOTE: Individual subsystems of the CDP use similar, but not identical nomenclatures. For example, the GUI FLAME event is referred to as FIRE by the LWVD subsystem as seen in Figure 6-13. The GUI nomenclature will be used in this section for consistency.

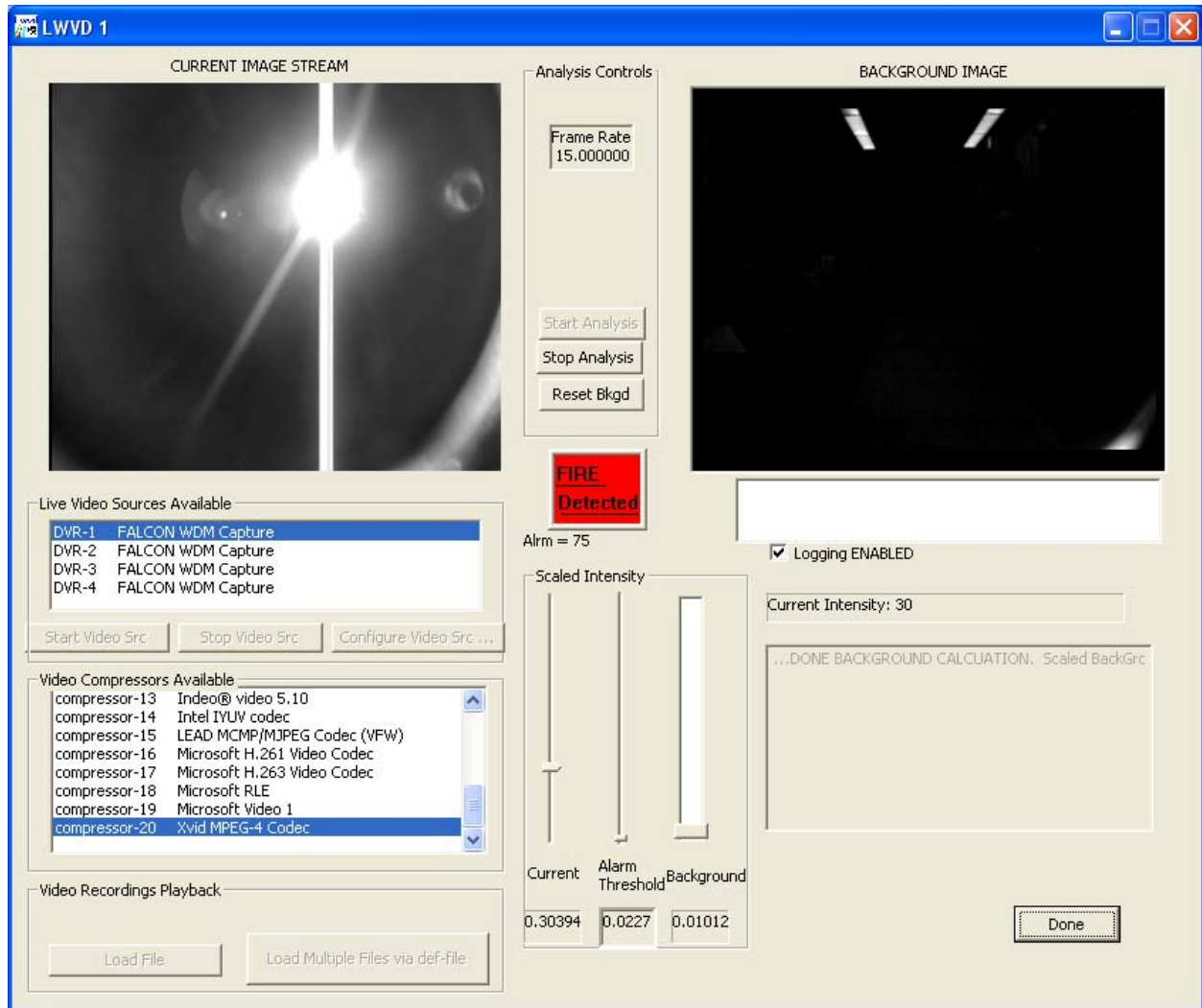

Figure 6-14 – LWVD main screen, system in a FLAME alarm state



Figure 6-15 – *SpyderGuard IP Camera Browser screen, system in a normal state*



Figure 6-16 – *SpyderGuard IP Camera Browser screen, system in a FLAME alarm state*

If all of these systems checks are positive, the CDP sensor subsystem components are operating nominally. At this point, the operator should stop the system and reset for actual demonstration testing.

6.5. Demonstration Procedures

This section briefly outlines the procedure for running a single test event as part of a test series. With all component-level software, data fusion, and UI elements properly up and running, the operator console for the CDP should closely resemble the scene shown in Figure 6-17. The procedures discussed in this Section briefly cover operator interaction with the VS_GUI application. For additional information about using the VS_GUI application, refer to Section 13.

When first started, the VS_GUI application is dormant and not communicating with the VS_CnC or any CDP subsystems. To initialize communications, the operator presses the “I” button on the application menu bar. The button is shown highlighted red in Figure 6-18. The initialization routine queries all devices in the CDP and updates the GUI as responses are received. A typical VS_GUI display after initialization is shown in Figure 6-19. To start the CDP data collection cycle, the operation presses the green circle that is now illuminated on the application menu bar, red highlighted in Figure 6-20. Once the system is started and data are being received by the VS_CnC, the VS_GUI display will be similar to the one shown in Figure 6-21. The CDP will continue to collect and analyze data until the operator stops data acquisition. Algorithm results and situational awareness cues will be provided to the operator. Examples are shown in the next section of the document. To stop data acquisition, the operator presses the red circle that is illuminated on the application menu bar, as shown highlighted red in Figure 6-22. The CDP is now in the idle state and ready for the next demonstration test.

NOTE: The VS_CnC and VS_GUI software have been tested extensively, but are at the core, research tools. If unexpected behavior is experienced, restarting the VS_GUI and possibly the VS_CnC application is recommended.

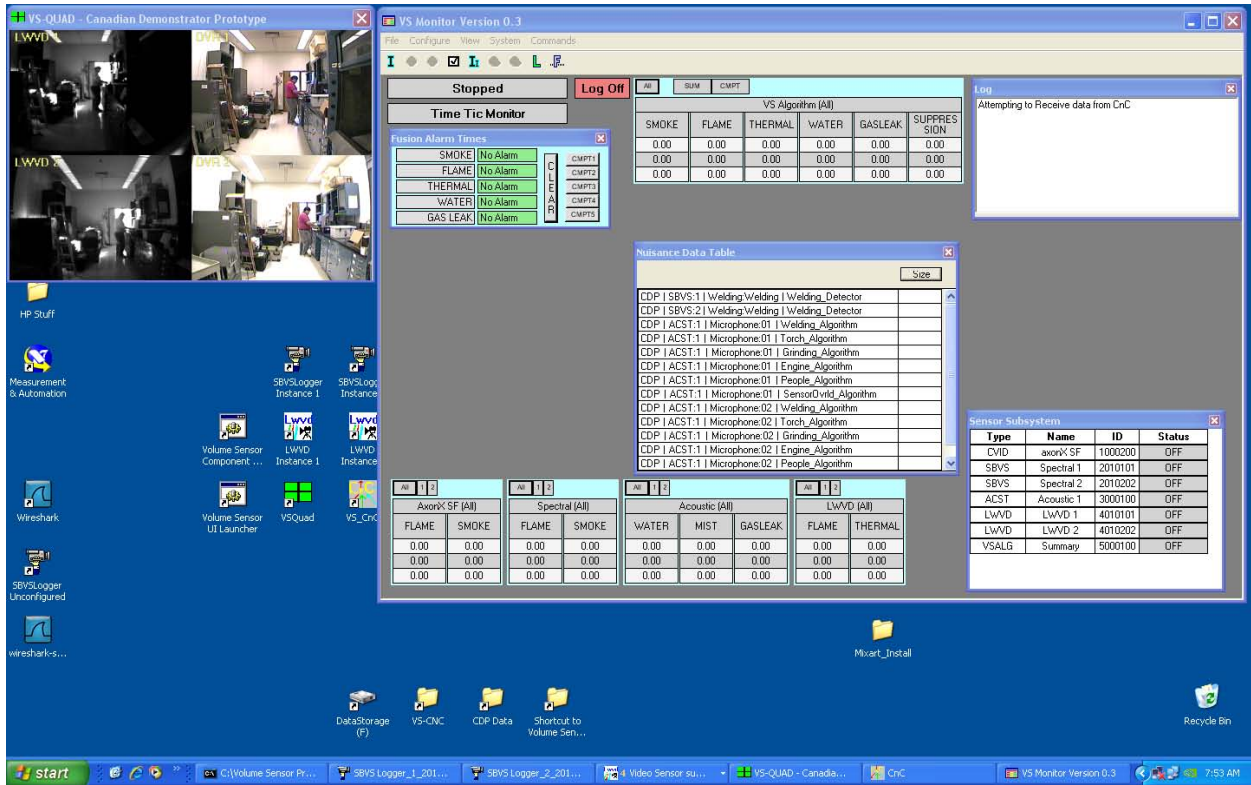

Figure 6-17 – CDP operator view after a clean system startup

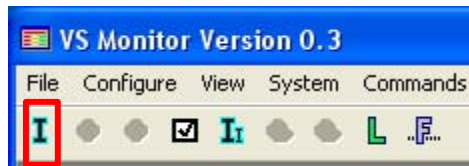

Figure 6-18 – Main VS_GUI Interface Controls – Pre-Initialization

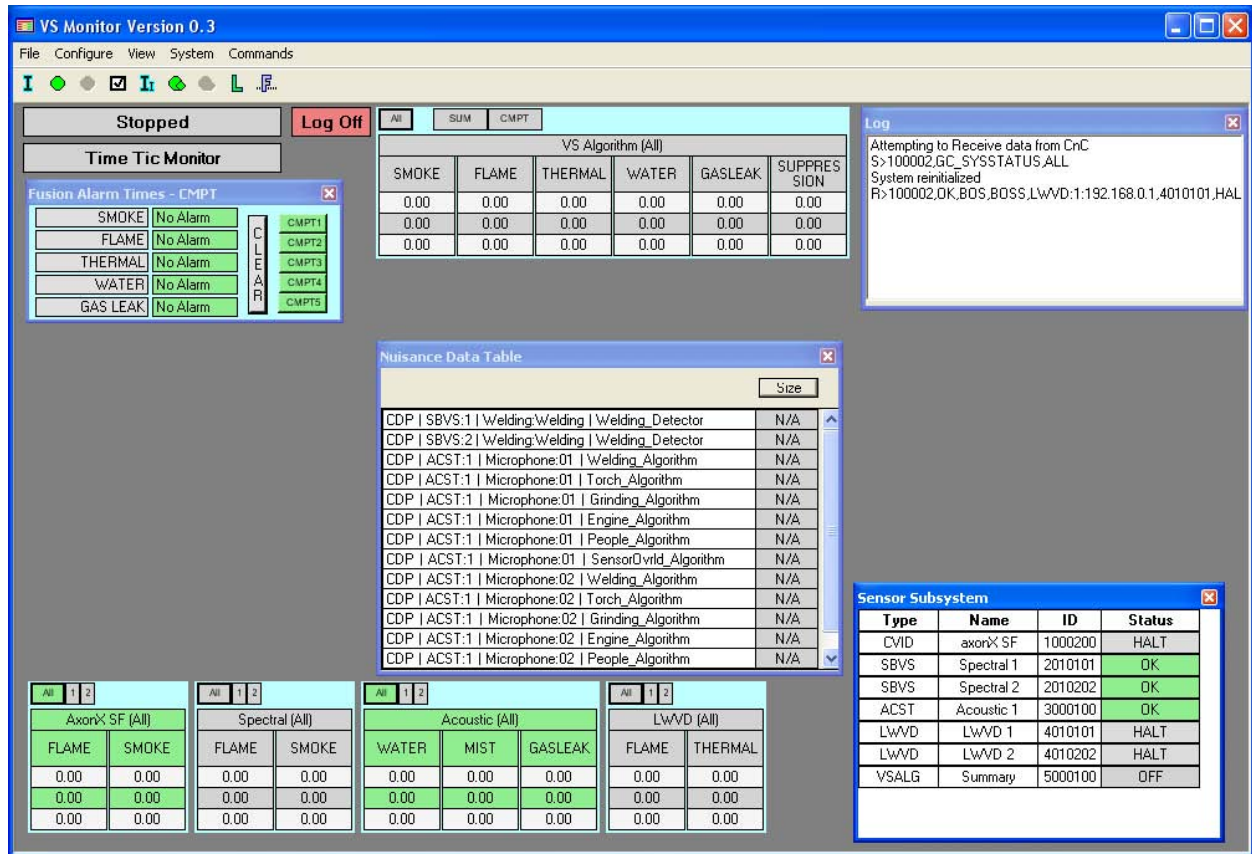

Figure 6-19 – CDP operator view after Initialization



Figure 6-20 – Main VS_GUI Interface Controls – Ready to Start

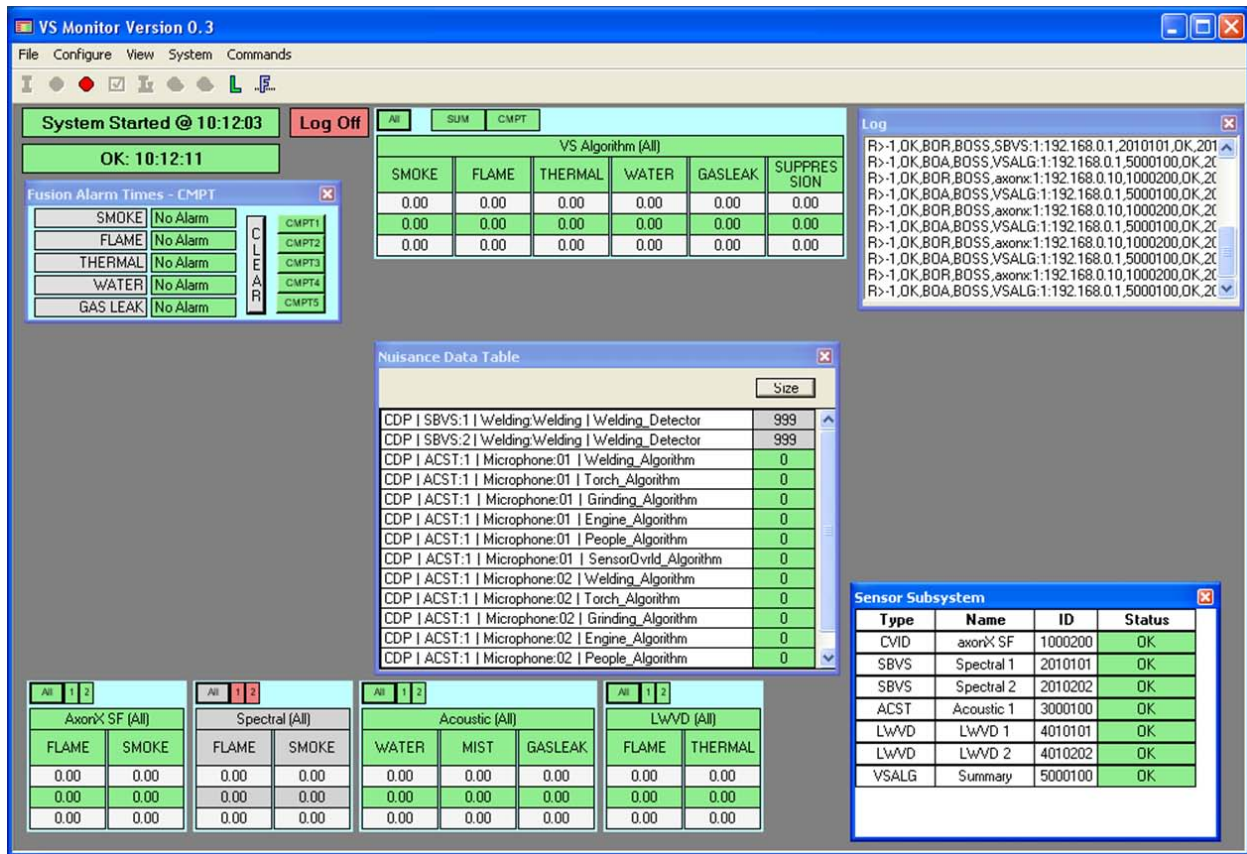

Figure 6-21 – CDP operator view with CDP collecting data

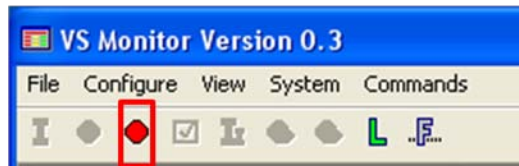

Figure 6-22 – Main VS_GUI Interface Controls – Running

6.6. Situational Awareness

The stated goal of the CDP system is to detect potential damage control events occurring in a compartment in a shipboard environment, classify them based on their hazard characteristics, reject known nuisance events, and present the operator and other damage control systems with the results leading to enhanced situational awareness. In this section of the document, the types of situational awareness that can be provided by the CDP and the mechanisms by which they are presented to the operator are discussed and two examples are shown.

The Volume Sensor Prototype, on which the CDP is based, is designed to detect flame and smoke events. Detection of smoke comes exclusively from the *SigniFire* system. Flame detection capabilities are provided by the *SigniFire*, LWVD, and SBVS components. The data

fusion algorithms running on the Fusion Machine computer weight these systems differently based on their demonstrated, past performance. Further details on this subject can be found in Reference 3 and the references within. As an example, the LWVD subsystem FLAME algorithm has been found to generate too many false positive responses to be allowed to generate a FLAME EVENT on its own. Corroboration from another subsystem is required. As an example, in Figure 6-23, the LWVD component for both CPD sensor heads is indicating a FLAME pre-alarm condition (see red-highlighted section). The overall system status is nominal (all green indications). As the event continues to evolve, the LWVD subsystem reaches a FLAME alarm condition, as shown in Figure 6-24 (red-highlighted section). The overall system status remains nominal (all green indications) as the data fusion algorithms will not declare a FLAME event based on the LWVD subsystem alone. As the event continues, the SBVS and LWVD now both indicate a FLAME alarm condition, as indicated by the red highlighted sections in Figure 6-25. The data fusion algorithms now determine that the FLAME event is real and declare a system wide FLAME alarm condition, as indicated in the purple-highlighted sections of Figure 6-25.

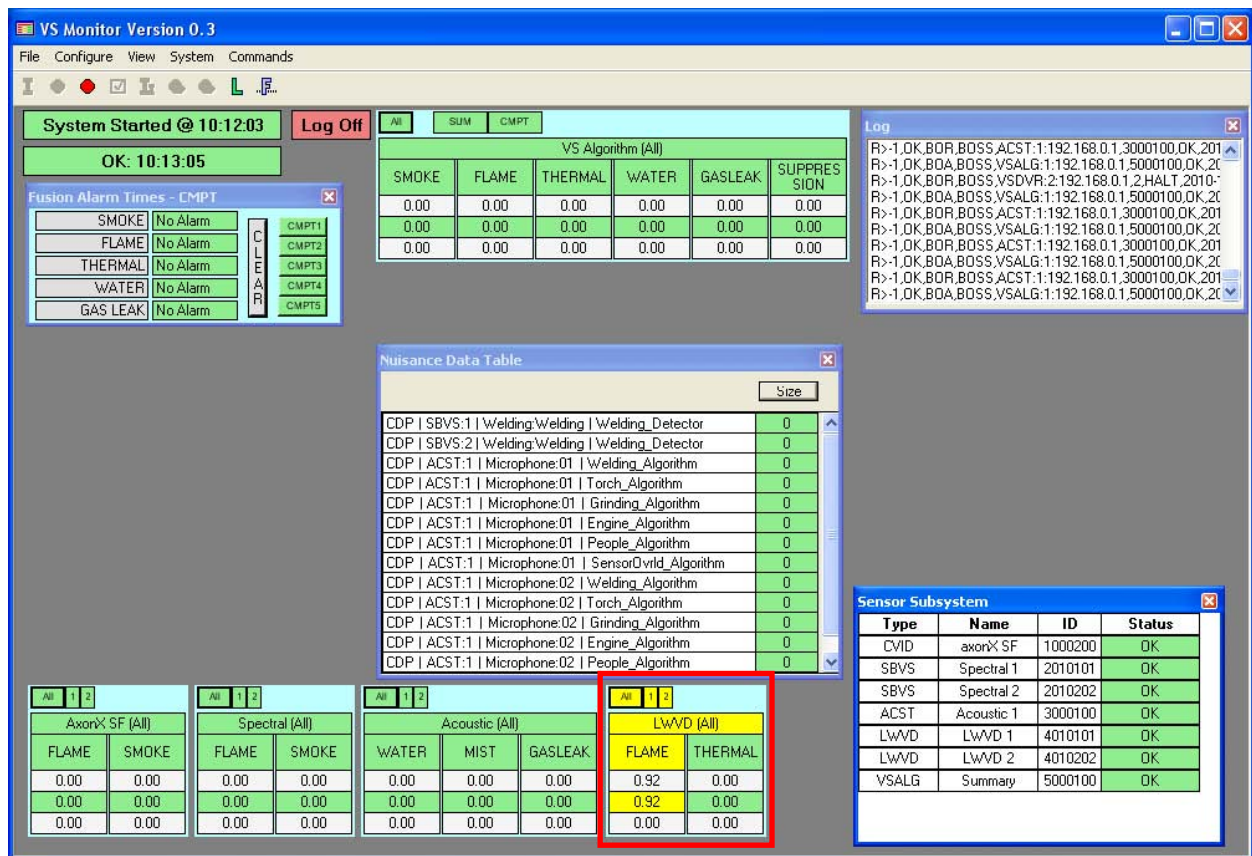

Figure 6-23 – VS_GUI indicating an LWVD-based FLAME pre-alarm condition

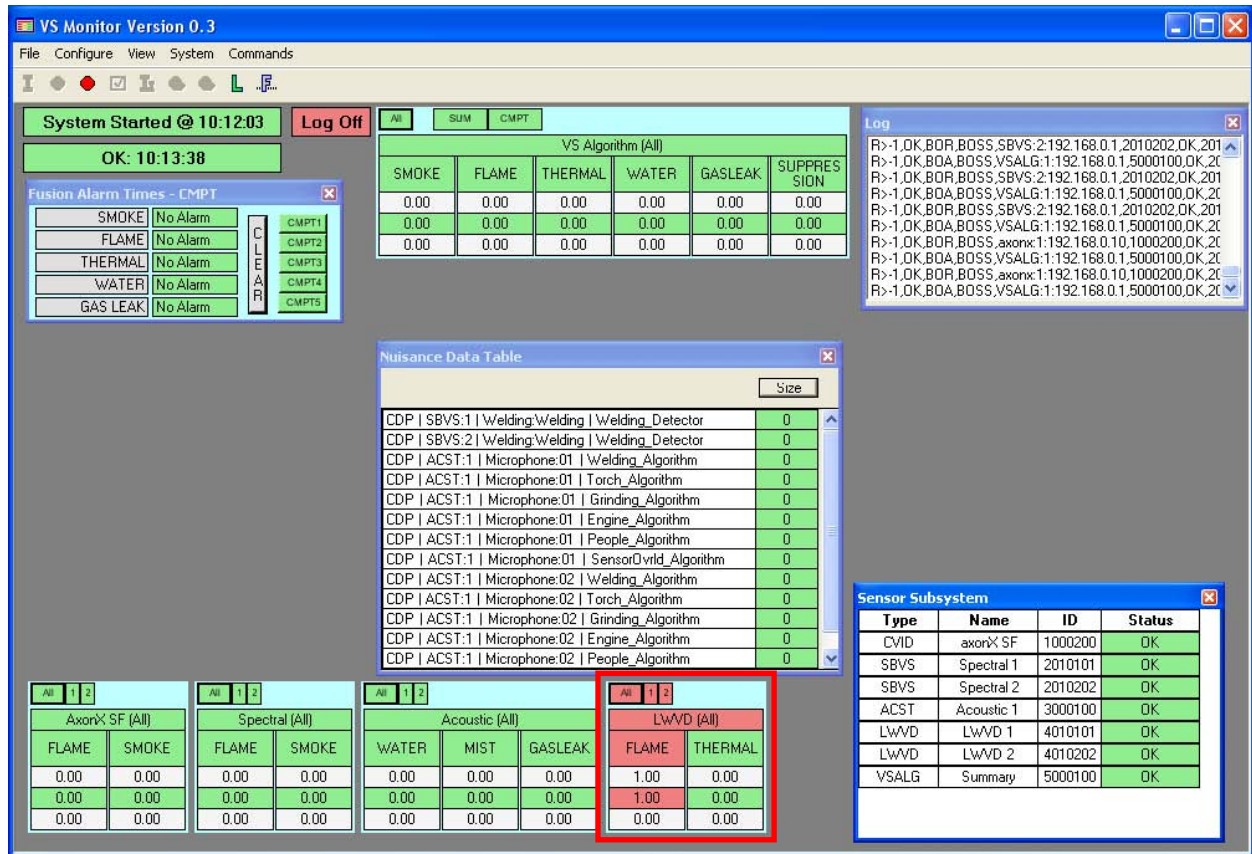

Figure 6-24 – VS_GUI indicating an LWVD-based FLAME alarm condition

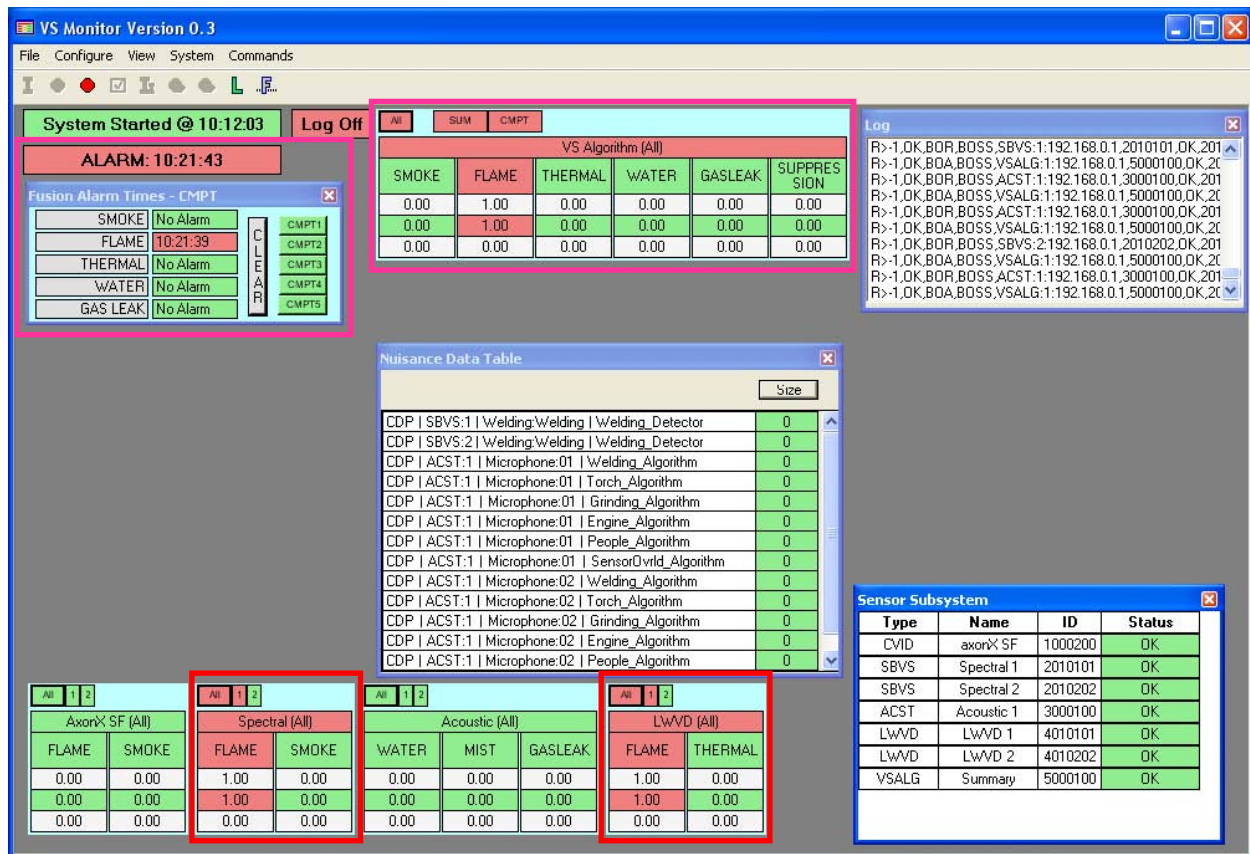

Figure 6-25 – VS Data Fusion Algorithms declaring a FLAME event based on the LWVD and SBVS subsystems

NOTE: In Figure 6-24, the LWVD FLAME alarm condition was indicated by both SS #1 and #2, as indicated by the red illumination of the “All”, “1”, and “2” boxes at the top of the red-highlighted area. In Figure 6-25, the fire source had evolved such that the SBVS and LWVD subsystems in SS #1 indicated a FLAME alarm condition (indicated by the red illumination) but SS #2 has returned to nominal status (indicated by the green illumination).

The Volume Sensor Prototype data fusion algorithms are also designed to detect several nominal shipboard conditions and bring them to the operator’s attention for enhanced situational awareness. The majority of these conditions are driven by the acoustics subsystem.

The ACST subsystem monitors the ambient noise in the test compartment and when sounds typical of an event, such as water falling, are detected, it reports a WATER or other event based on the noise detected. This is done through two types of data passed to the Fusion Machine, channel data and alarm status for each event. The channel data represents an estimate of the probability of an event. As an event persists, the alarm level is continually raised until it is considered fully set and an event is formally considered detected. Table 6-1 lists the different

types of events looked for by the acoustic processing software. The abbreviation column is used in real-time monitoring of the processing in a terminal window, see Figure 6-7.

Table 6-1 – Audio Events and Alarms

Event	Abbreviation	Alarm Type
Sensor Overload	O	Event
Background Noise	N	Background
Water	W	Pipe Rupture
Mist	M	Event
Gas Leak	G	Event
Torch	T	Nuisance
Grinding	R	Nuisance
Welding	L	Nuisance
Engine	E	Nuisance
People	P	Nuisance
Activity	H	Nuisance

The Water and Gas Leak ACST events are treated as damage control events and annunciated to the operator in the same manner and screen locations as FLAME and SMOKE. The remaining events are annunciated as nuisance events. Nuisance events are presented to the operator for general situational awareness and also as a reminder of the CDP operating status. These events are annunciated in the Nuisance Data Table section of the VS_GUI screen, as shown in Figure 6-26. For example, the SBVS subsystem generates one positive nuisance event condition, the presence of arc welding. If the SBVS subsystem reports the presence of an arc welding nuisance in the compartment, all data fusion alarm conditions (*i.e.* FLAME and SMOKE) for the compartment are blocked from activating until one minute after the WELDING event has cleared. The indication of the WELDING nuisance on the VS_GUI display warns the operator that FLAME alarms are currently blocked. An example of a pre-alarm condition for the PEOPLE event is shown in Figure 6-27.

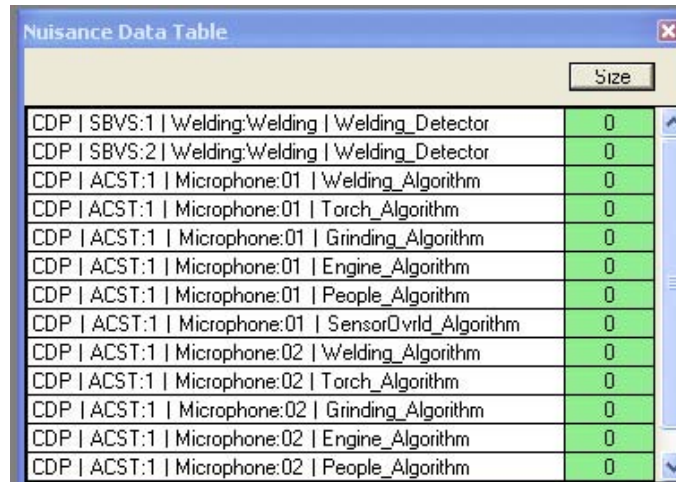

Nuisance Data Table			Size
CDP SBVS:1 Welding:Welding Welding_Detector			0
CDP SBVS:2 Welding:Welding Welding_Detector			0
CDP ACST:1 Microphone:01 Welding_Algorithm			0
CDP ACST:1 Microphone:01 Torch_Algorithm			0
CDP ACST:1 Microphone:01 Grinding_Algorithm			0
CDP ACST:1 Microphone:01 Engine_Algorithm			0
CDP ACST:1 Microphone:01 People_Algorithm			0
CDP ACST:1 Microphone:01 SensorOvrld_Algorithm			0
CDP ACST:1 Microphone:02 Welding_Algorithm			0
CDP ACST:1 Microphone:02 Torch_Algorithm			0
CDP ACST:1 Microphone:02 Grinding_Algorithm			0
CDP ACST:1 Microphone:02 Engine_Algorithm			0
CDP ACST:1 Microphone:02 People_Algorithm			0

Figure 6-26 – VS_GUI Nuisance Data Table

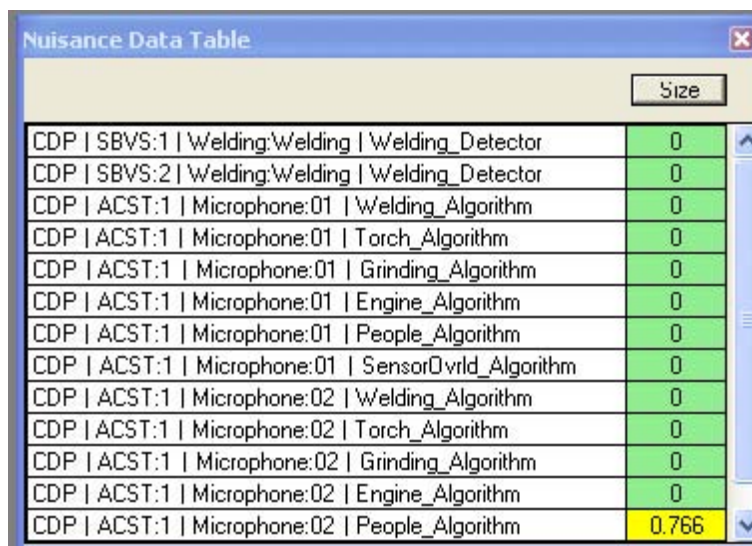

Nuisance Data Table			Size
CDP SBVS:1 Welding:Welding Welding_Detector			0
CDP SBVS:2 Welding:Welding Welding_Detector			0
CDP ACST:1 Microphone:01 Welding_Algorithm			0
CDP ACST:1 Microphone:01 Torch_Algorithm			0
CDP ACST:1 Microphone:01 Grinding_Algorithm			0
CDP ACST:1 Microphone:01 Engine_Algorithm			0
CDP ACST:1 Microphone:01 People_Algorithm			0
CDP ACST:1 Microphone:01 SensorOvrld_Algorithm			0
CDP ACST:1 Microphone:02 Welding_Algorithm			0
CDP ACST:1 Microphone:02 Torch_Algorithm			0
CDP ACST:1 Microphone:02 Grinding_Algorithm			0
CDP ACST:1 Microphone:02 Engine_Algorithm			0
CDP ACST:1 Microphone:02 People_Algorithm			0.766

Figure 6-27 – VS_GUI Nuisance Data Table indicating People in the Space

The discussion in this section gives a brief introduction to the rich set of information and situational awareness provided by VSP systems such as the CDP. For further discussion, refer to Section 13.

6.7. Data Output

Most of the CDP data files are stored on the Fusion Machine computer's data drive (F:\) in directories by component. The data fusion data files are stored on the computer's main drive and should be archived after each demonstration test. A pair of desktop shortcuts has been set up to facilitate data backups, as shown in Figure 6-28. The data fusion data files to be archived from the main drive (C:\) are:

- DFAM_Log.txt
- dataSS1_Log.txt, dataSS2_Log.txt
- dataDF1_Log.txt
- CnC_Logfile_MM-DD_YY__HH-MM-SS.txt

These files are located in the VS-CnC application directory,

"C:\Volume Sensor Programs\VS-CnC"

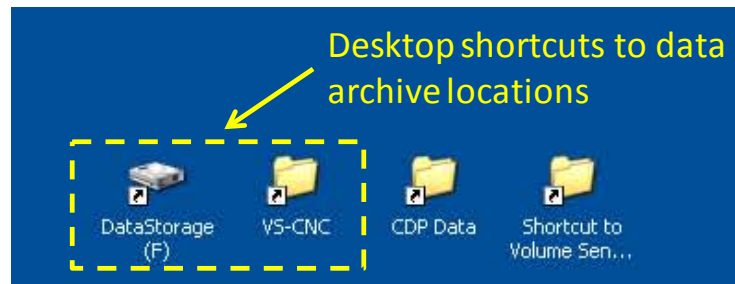

Figure 6-28 – Desktop Shortcuts for Data Archiving

The SBVS and LWVD data files are individually time-stamped as described in Sections 7.3 and 8.2.3. It is recommended that the SBVS, LWVD, and DVR data files be archived at the end of each day into test-specific directories. The data directories can be reached quickly by double-clicking the "DataStorage (F)" desktop shortcut. The SBVS data files are stored in the directory:

"F:\SBVS Data Files\"

The LWVD application generates several types of data files, as described in Section 8.2.3, including archival video files. In DVR mode, the LWVD application only records archival video files. The LWVD and DVR data files are stored in the directory:

"F:\LWVD Data Files\"

The ACST subsystem does not store data locally under normal operating conditions. See Section 9.4 for further details on the ACST subsystem testing mode which does enable local data storage. Any saved files for the ACST subsystem are stored in the directory:

"F:\ACST Data Files\"

6.8. System Shutdown

System shutdown procedures are divided into two categories: routine, daily shutdown for during a test series and complete shutdown for disassembly and storage.

During a running test series, the following software applications should be secured at the end of each work day in the order listed:

1. VS_GUI
2. VS_Quad
3. VS_CnC
4. SBVS (Optical sensors) for SS#1
5. SBVS (Optical sensors) for SS#2
6. ACST (Acoustics) for SS#1 and #2
7. LWVD Machine Vision for SS #1
8. LWVD Machine Vision for SS #2
9. DVR (CCTV recording) for SS #1
10. DVR (CCTV recording) for SS #1

Prior to securing any software, the operator should insure that all systems have stopped recording data. Each software package is closed using one of the standard Windows paradigms. The LWVD, DVR, and VS_CnC applications have a “Done” button on the main GUI. Pressing this button closes the application. The VS_GUI and SBVS applications are closed by selecting the menu choice “File/Exit”. The VS_Quad application is closed by pressing the “x” in the upper-right hand corner of the application window. The ACST application is closed by pressing the “q” button.

The applications running on the *SigniFire* computer should be left running.

For routine, daily hardware shutdown, the Fusion Machine computer, the phantom power supply, and Fieldpoint Unit should now be turned off. The CDP sensor heads should be left powered overnight unless the recommended 120 minute warm up time is available each day.

If the system is to be powered down for an extended period, the two applications running on the *SigniFire* computer should be shut down. The *SigniFire* computer should be shutdown. Finally, the network switch and CDP sensor heads should be turned off. To protect against power conditioning issues, all power cords and plug strips should be disconnected from their supply outlets.

7. Spectral-Based Volume Sensor (SBVS) Component

Routine operation of the SBVS component for the CDP is straightforward and requires no operator intervention. For advanced configuration and usage, additional information is required and is presented in this Section. The information in this Section is excerpted for Reference 10.

7.1. SBVS Data Acquisition Electronics

Data acquisition (the conversion of analog signals to digital information) is performed in the SBVS Fieldpoint Unit. The Fieldpoint Unit is shown in Figure 7-1.



Figure 7-1 – SBVS Fieldpoint Unit

An interior view of the Fieldpoint Unit is shown in Figure 7-2.



Figure 7-2 – Interior View of SBVS Fieldpoint Unit

At the heart of the Fieldpoint Unit is a National Instruments compact Fieldpoint (cFP) distributed data acquisition system (cFP-2000). Standard 9-pin serial cables are used to connect the SBVS sensors in the CDP sensor heads to the data acquisition electronics at distances of up to 50 feet. The electrical connections from the CDP sensor heads to the Fieldpoint Unit to the data processing PC are shown in Figure 7-3. Analog signals are shown as solid lines and digital (network) connections are shown as dashed lines.

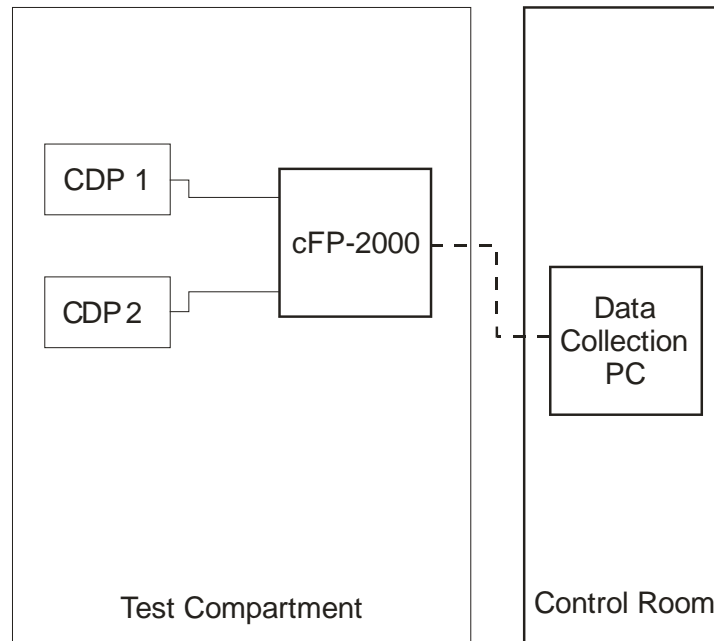

Figure 7-3 – Schematic Wiring Diagram for the SBVS Component

The Fieldpoint Unit, as configured, is capable of operating three CDP sensor heads at one time. However, the planned configuration of the CDP as a whole will only support the operation of two sensor heads at a time. The Fieldpoint Unit contains a network control module (cFP-2000), an analog input (AI) module (cFP-AI-110), and a digital counter module (cFP-CTR-502). The cFP-2000 module handles the data acquisition and communication with the data processing PC. The AI module has 8 single-ended inputs. Each input is configured for a 0-10.4 VDC input range to match the outputs of the sensors and a 60 Hz line filter is applied. The inputs are used in pairs, one for the IR sensor and one for the NIR sensor for a given CDP sensor head. Three pairs (6 total) are wired to the front panel for connection to CDP sensor heads. Wire connections to the AI module are made using a cFP-CB-1 terminal block. The remaining two pairs are dead-shortened to prevent baseline drift. The connection information for the analog inputs is listed in Table 7-1.

Table 7-1 – Wiring Connection Pinout for SBVS Fieldpoint Analog Inputs

Connection	Terminal Block Pin	Wire Color	cFP DB-9 # / Input Pin
IR Signal 1	1	Red	1 / 1
IR Ground 1	18	Green	1 / 6
NIR Signal 1	3	Black	1 / 3
NIR Ground 1	20	White	1 / 7
IR Signal 2	5	Red	2 / 1
IR Ground 2	22	Green	2 / 6
NIR Signal 2	7	Black	2 / 3
NIR Ground 2	24	White	2 / 7
IR Signal 3	9	Red	3 / 1
IR Ground 3	26	Green	3 / 6
NIR Signal 3	11	Black	3 / 3
NIR Ground 3	28	White	3 / 7

The UV sensor output is a series of pulses rather than a continuous voltage level. A digital counter (CTR) (cFP-CTR-502) is used to count the number of pulses in a given time period, typically one second. The counter is designed to count pulses of arbitrary voltages for eight input channels, so an appropriate reference voltage is also required. A +5 VDC reference voltage is provided by a power supply in the Fieldpoint Unit and wired to the CTR module separately. +5 VDC is used to match the amplitude of the pulse train from the UV sensor and the CTR input bandwidth is set to 50 kHz to match the pulse width. Wire connections to the CTR module are made using a cFP-CB-1 terminal block. The connection information for the digital inputs is listed in Table 7-2.

Table 7-2 – Wiring Connection Pinout for SBVS Fieldpoint Digital Inputs

Connection	Terminal Block Pin	Wire Color	cFP DB-9 # / Input Pin
UV Signal 1	1	Black	1 / 5
UV Ground 1	18	White	1 / 9
UV Signal 2	2	Black	2 / 5
UV Ground 2	20	White	2 / 9
UV Signal 3	3	Black	3 / 5
UV Ground 3	22	White	3 / 9
+5 VDC Ref.	V	Red and Black	N/A
Ref. Gnd	C	Green and White	N/A

7.2. SBVSLogger Software

The SBVSLogger application is designed to communicate with the SBVS Fieldpoint Unit to collect the sensor data, process the data using the VS SBVS Component Prototype algorithms, and pass the sensor data and algorithm results to the VS Data Fusion Algorithm via the VS_CnC application. While the SBVSLogger software has a full user interface (GUI), it is designed to be

run in an unattended mode once configured. The configuration and operation of the software is briefly described here.

Upon startup, the main screen of the SBVS application is displayed, as shown in Figure 7-4. The SBVS sensors in each CDP sensor head are monitored collectively by an instance of the SBVSLogger application. The title bar of the application notes which instance is being monitored and the network communications definition numerical ID (NID) of the instance. There are three main controls for the application, which are accessed using the buttons on the application's toolbar. Data processing is initiated either manually by pressing the "Save" icon or as part of the CDP system by the VS_CnC application via the network. Data processing is stopped either manually by pressing the "Stop" icon or as part of the CDP system by the VS_CnC application via the network. System configuration is accessed by pressing the righthand icon (a hand pointing at a document). The current raw sensor output values (voltage for the IR and NIR sensors, counts for the UV sensor) are displayed in the first row of text boxes. The second row will contain the background-corrected and scaled sensor values once data processing has been started and a 20-second (default) background sample is collected. The final row of indicators indicates the status of the SBVS algorithm outputs. The value Sum_N is similar to signal amplitude for the algorithms. The four indicator lights turn from green to red when the corresponding event is detected by the SBVS algorithms.

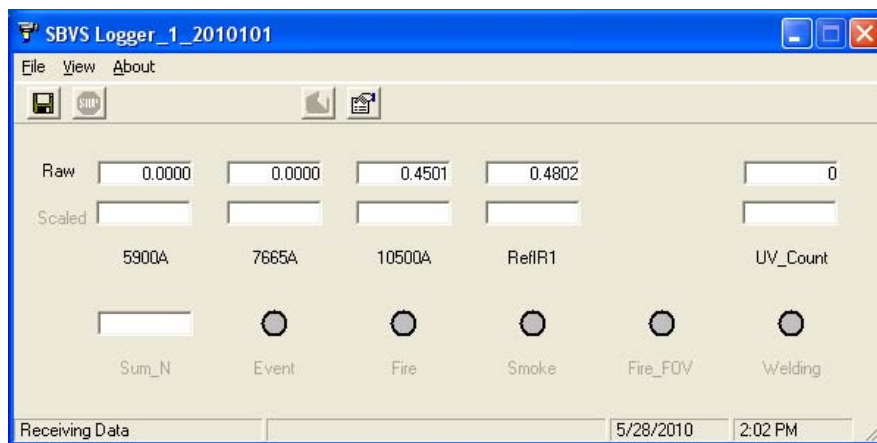

Figure 7-4 – SBVSLogger main screen, system idle

7.3. SBVSLogger Standard Configuration

The configuration information for SBVSLogger is stored in two places. The primary location is in the Windows Registry in the key [HKEY_CURRENT_USER\Software\VB and VBA Program Settings\SBVSLogger]. The stalwart user can do all configuration tasks using the REGEDIT application included with Microsoft Windows. A complete listing of the reference configuration for the CDP is included in Reference 10. The configuration screens of the SBVSLogger application provide a simpler, UI-based method for configuration. The configuration screens are

accessed by pressing the right hand-most button on the application toolbar (the hand pointing at a page icon). The network communication definition for each instance is stored in an .xml file stored at a location indicated in the windows registry. An example is given in Reference 10.

The SBVSLogger configuration is split into three Options tabs. The first tab is the ‘Data Logging’ tab, shown in Figure 7-5. There are two methods available for automatically generating SBVS filenames, the radio buttons on this tab allow the user to choose which method is used. The Date/Time method is preferred. The main configuration option on this screen is the location for storing SBVS data files. A standard Windows interface is provided for choosing a directory for storing data files and for making a new directory from within the program.

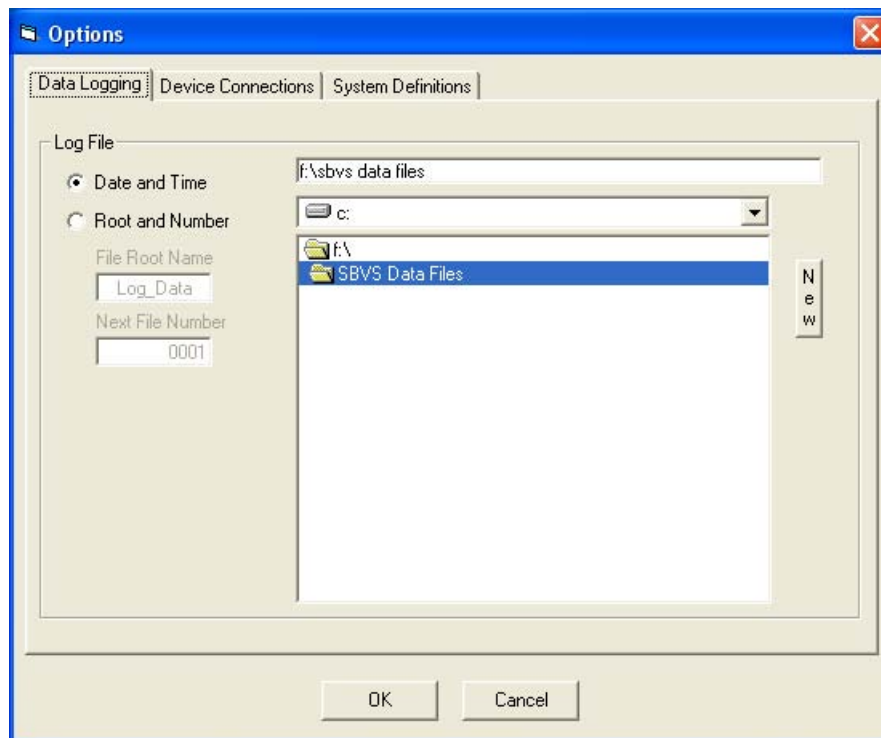

Figure 7-5 – SBVSLogger Data Logging Options Screen

The next tab is the ‘Device Connections’ tab, shown in Figure 7-6. This is where the Fieldpoint Unit inputs are mapped to the raw data channels of the SBVSLogger application for a given instance. First, an instance is selected (existing or new). Then a descriptor text string is provided for clarity. This string is used in no other place. The last item on the first line is the selection of which sensor head is connected by the device serial number. This tells the SBVSLogger application what calibration information to use to scale the raw data. Two connection strings are then listed which map analog input (-AI) and counter (-CTR) Fieldpoint modules to the instances. Below each are the specific channel mappings for the module and instance.

To remap the connection string which maps a specific cFP module (-AI or -CTR) in a specific Fieldpoint Unit to the selected instance, the user presses the 'browse' button. After navigating to the desired module, a specific channel must be selected to complete the process. However, this channel selection is not used. Instead, the row of channels below each connection string is then used to map individual channels to the SBVSLogger application data channels. In the example, the missing 590 and 766.5 nm channels are mapped to the grounded channel 7. For the counter input, a sparsing factor is specified. This setting tells the program how long to count pulses for a reasonable signal level to be achieved. If the analog inputs are set to 10 Hz, a sparsing factor of 10 sets a one second counting period for the UV sensor.

The final tab is the "System Definitions" tab, shown in Figure 7-7. This tab allows the user to specify location of the network configuration definition files that control the network communications of the SBVSLogger instance. Any valid system definition file (up to three total) in the specified directory will be used.

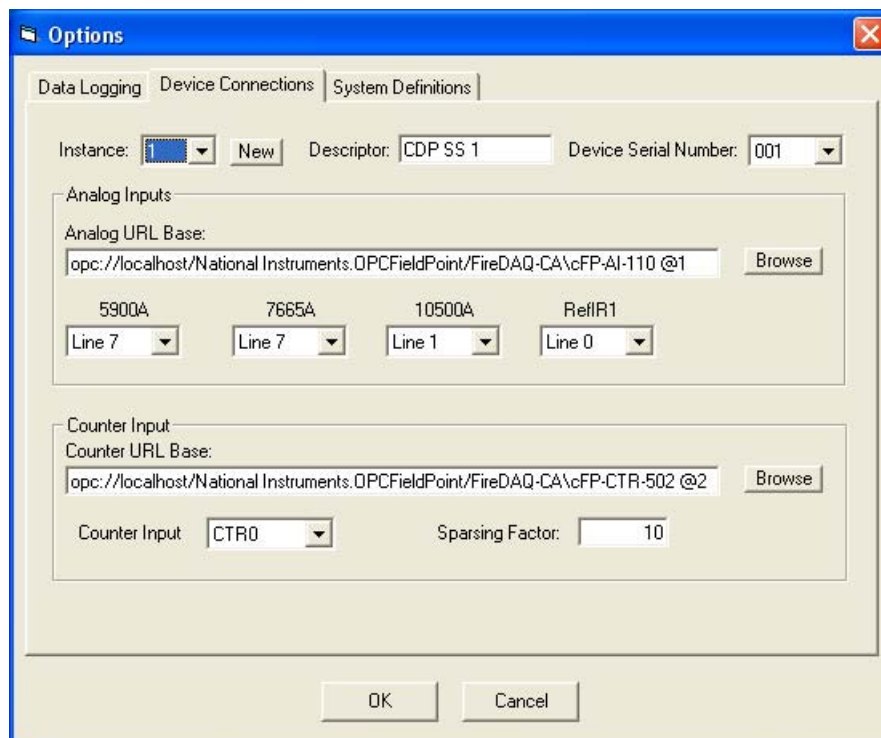

Figure 7-6 – SBVSLogger Device Connection Options Screen

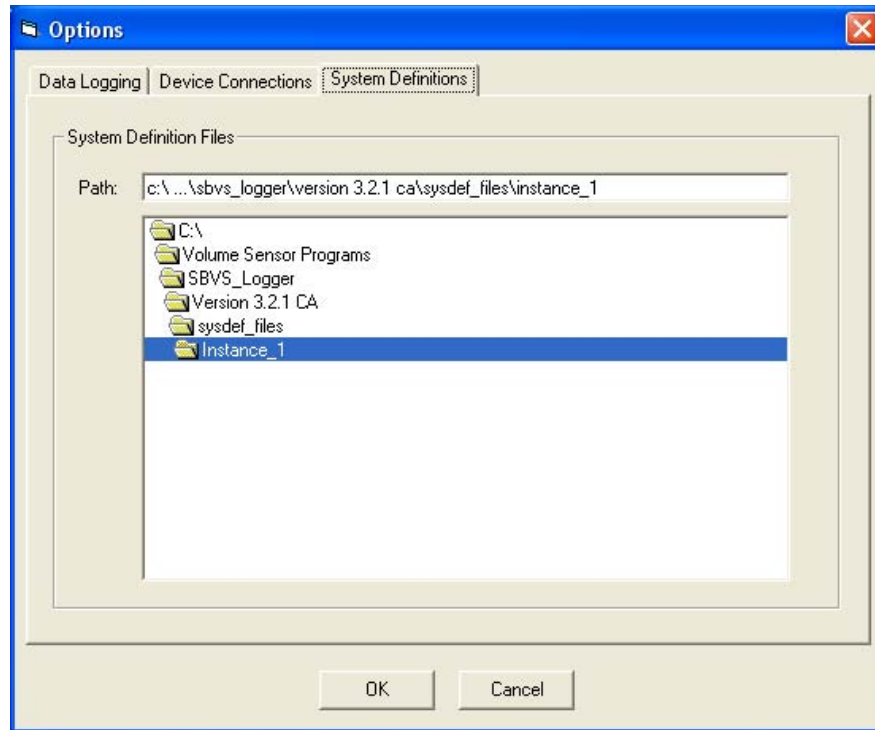

Figure 7-7 – SBVSLogger System Definitions Options Screen

7.4. SBVSLogger Extended Configuration

The configuration options discussed in the previous section are those that typically vary from installation to installation. There are additional configuration options that do not typically require modification. If the application is launched with a negative instance number, for example,

```
"C:\Volume Sensor Programs\SBVS_Logger\Version 3.2.1 CA\SBVSLogger.exe" -1
```

The SBVSLogger Setup Screen can be accessed, as shown in Figure 7-8. Here it is possible to select which of the five possible analog inputs from the VSP SBVS Component Prototype are active and the names displayed for them in the main screen. The active state of the counter input can also be controlled here. For CDP use, the first four analog inputs and the counter input should remain active and the fifth analog input should remain inactive. Also the persistence requirement for the five SBVS Component algorithms can be set. Note that for a new installation, all persistence values are set to 5 seconds by default. The analog data sampling rate is also set here, 10 Hz by default. The number of data samples to acquire at the beginning of data processing is also set here with a default of 200 samples (20 seconds at 10 Hz). The ‘Use Photodiode’ checkbox controls the use of all photodiodes in the event algorithms. For CDP use, this checkbox should remain checked. The final set of checkboxes controls what output options are active. The ‘Scaled’ checkbox controls whether or not the scaled sensor values are saved to the local data files. The ‘Retain’ checkbox controls whether or not the local data file is saved if

the only active data request is a network request from a VS_CnC request. The “VSCS” checkbox controls whether or not all network communications traffic is logged locally for debugging purposes. All of the shown settings are the recommended values.

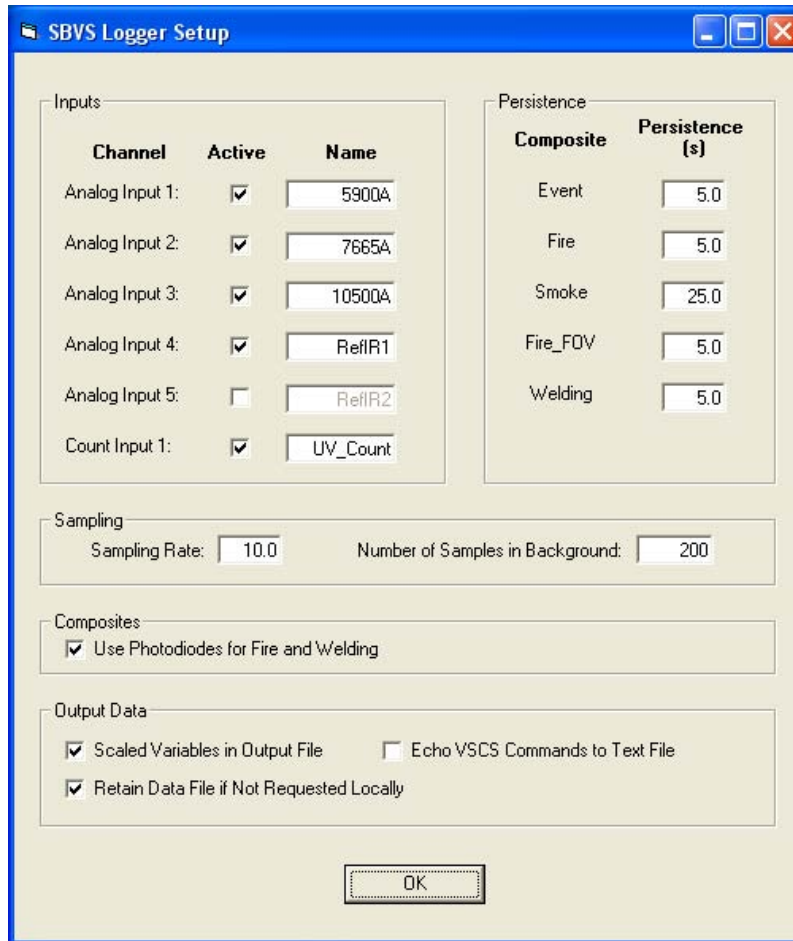

Figure 7-8 – SBVSLogger Setup Screen

7.5. SBVSLogger Operation

The SBVSLogger application can be launched in one of three ways: 1) double-clicking on the executable or an associated shortcut and selecting the desired instance, 2) launching from the command line (or batchfile) with the instance number specified, or 3) by double-clicking on an associated shortcut with the instance number specified in the command line arguments. Options 2 and 3 are recommended for unattended operation. An example target for a shortcut to launch instance 1 is:

```
"C:\Volume Sensor Programs\SBVS_Logger\Version 3.2.1 CA\SBVSLogger.exe" 1
```

If the instance is properly configured, the application will launch and run in the idle state as shown in Figure 7-4. When a ‘start data processing’ command is received either locally or from

a network VS_CnC, background collection will commence. The main screen will change to reflect the application's operating status, as shown in Figure 7-9. After the background collection period is over, the system reaches the data processing stage where all incoming data are evaluated by the five algorithms, as shown in Figure 7-10. When one of the algorithms detects an event, the status indicators on the display change to indicate the detected events. In Figure 7-11, two SBVS EVENTS are indicated, EVENT and FIRE_FOV.

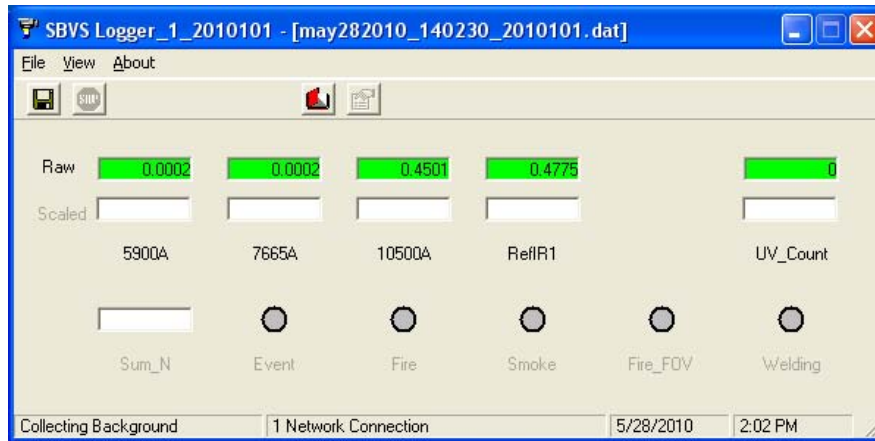

Figure 7-9 – SBVSLogger main screen, system collecting background data

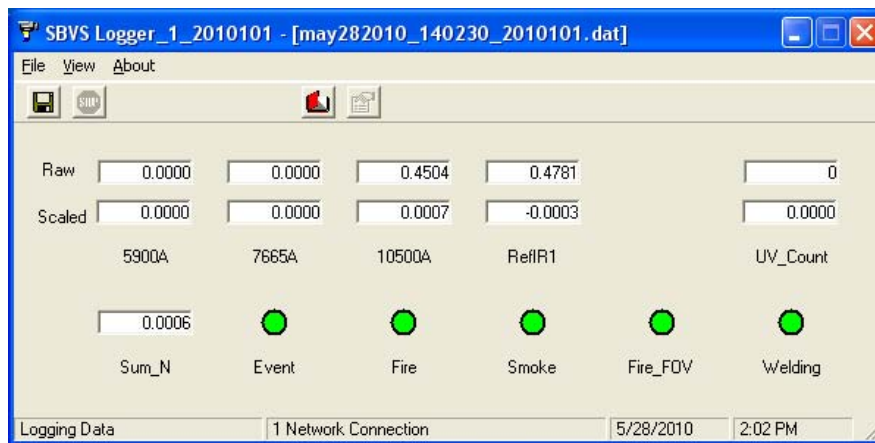

Figure 7-10 – SBVSLogger main screen, system processing incoming data

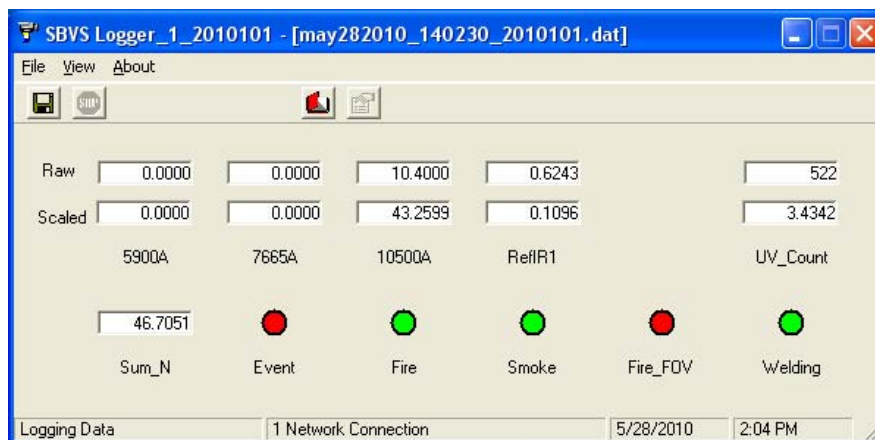

Figure 7-11 – SBVSLogger main screen, system detecting a FIRE_FOV EVENT

7.6. Sensor Head Calibration

To handle sensor-to-sensor variability in response, a unique set of Scale Factors, or calibration factors, need to be generated for each sensor head. These Scale Factors, coupled with the averaged background data from each test run, are used to calculate the scaled data for each sensor from the raw data. The mapping of Scale Factors to SBVSLogger instances is discussed in Section 7.3.

The recommended procedure for determining the Scale Factors for a sensor head is outlined below. It is recommended to also measure the response of a previously-calibrated sensor head at the same time as a cross-check. The sensors should be powered and allowed to completely equilibrate thermally, preferably for several hours prior to calibration. Each unit to be calibrated should be placed at roughly eye level. A calibration lamp is then used to provide a reference signal to each sensor. A unit similar to the Senseware T-229/1 UV/IR OFD test lamp, shown in Figure 7-12, is recommended. The T-229/1 is basically a large halogen flashlight with a 5” diameter reflector and a metal grill in place of the typical plastic lens. With the sensor head powered and connected to the Fieldpoint Unit, start data processing, allow the background to collect. Then illuminate each sensor element in the sensor head for 10 seconds with 10 seconds of background in between each sensor. This measurement should be made with the lamp located at distances of 12 and 18 feet from the sensor head. Due to the sensitivity of the NIR sensor element, the 18 feet measurement distance is required to get an unsaturated measurement. Scaled and raw data are related by the Scale Factors by the relationship:

$$\text{Scaled Data} = \frac{\text{Raw Data}}{\text{Scale Factor}}$$



Figure 7-12 – Senseware T-229/1 UV/IR OFD test lamp

At distances of 12 and 18 feet, the response due to the T-229/1 Test Lamp should yield scaled data as indicated in Table 7-3.

Table 7-3 – Scaled Data Voltages for Standard Test Lamp and Distances

Sensor Element	12' Scaled Data (V)	18' Scaled Data (V)
UV	5.300	
IR	0.080	
NIR		22.2

8. Long-Wavelength Video Detection (LWVD) Component

Routine operation of the LWVD component for the CDP is straightforward and requires no operator intervention. For advanced configuration and usage, additional information is required and presented in this Section. The information in this Section is excerpted for Reference 11.

8.1. LWVD Data Acquisition Electronics

Data acquisition (the conversion of analog signals to digital information) is performed by a 4-channel frame grabber (IDS Falcon Quattro, PCI-E version) installed in the local data processing computer (PC). The Falcon Quattro card is capable of simultaneously capturing 4 channels of live video at the full analog video frame rate, 29.97 Hz for NTSC. While the frame grabber is capable of capture video of a variety of standards, the VS software provided as part of the CDP assumes that the video sources are of the NTSC format. Standard 75-ohm coaxial cables are used to connect the LWVD camera in the CDP sensor head to the frame grabber. Cable lengths of greater than 50 feet should include the use of video amplifiers to prevent signal

degradation. The electrical connections from the CDP sensor heads to the data processing PC are shown in Figure 8-1. Analog signals are shown as solid lines. An external view of the frame grabber backplane is shown in Figure 8-2 with the video inputs channels labeled for reference. The frame grabber provides four input video channels, enough to operating two CDP sensor heads simultaneously (two video channels per sensor head, two sensor heads).

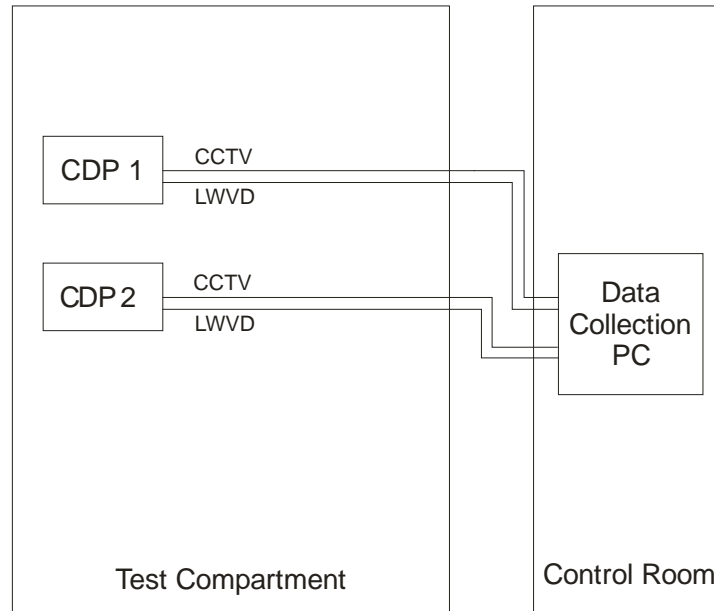

Figure 8-1 – Schematic Wiring Diagram for the LWVD Component

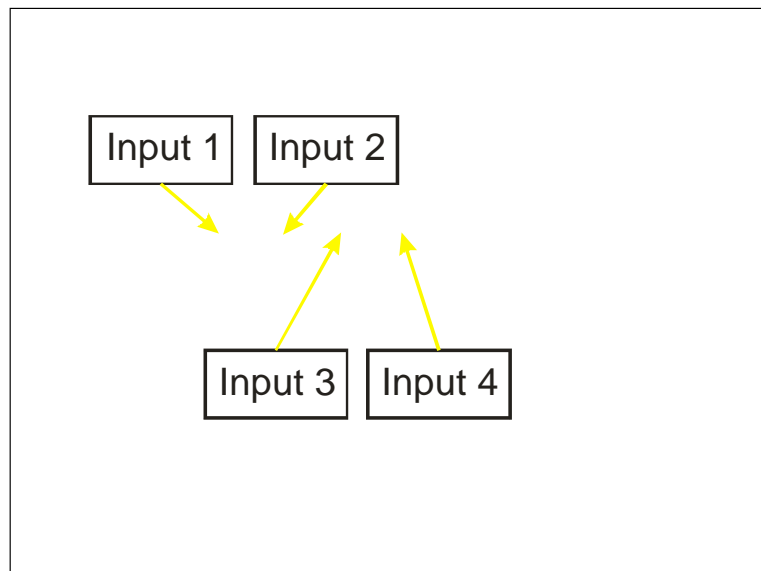

Figure 8-2 – External View of Frame Grabber Backplane with Inputs Labeled

8.2. LWVD Software

For the CDP, the intention is to install and run two CDP sensor heads, each with a color video camera and a NIR-filtered black and white camera, for a total of four video feeds. Both black and white video feeds will be recorded and processed by the LWVD algorithm for event detection purposes. Both color video feeds will be recorded only. Given the desire to conduct all CDP data collection and processing on a single PC and the similarities in program requirements for the color and black and white video, a single software application was developed to handle any one video input based on the configuration file used. One instance of the application can be run for each frame grabber input.

The LWVD application is designed to run in one of two modes, depending on configuration. In LWVD mode, the application is designed to collect video data from a single input of the local frame grabber, record the video in a standard video format (.avi), process the data using the VS LWVD Component Prototype algorithm, and pass the sensor data and algorithm results to the VS Data Fusion Algorithm via the VS_CnC application. In DVR mode, the application is designed to collect video data from a single input of the local frame grabber and record the video in a standard video format (.avi). While the LWVD software has a full graphical user interface (GUI), it is currently intended to be run in an unattended mode. The configuration and operation of the software is briefly described here.

Upon startup, the main screen of the LWVD application is displayed, as shown in Figure 8-3. Each video camera in each CDP sensor head is monitored by a separate instance of the LWVD application. The title bar of the application can be used to denote which instance is being monitored, LWVD 1 in Figure 8-3.

In LWVD mode, there are three main controls for the application which are accessed using the UI buttons on the main screen. Data processing is initiated either manually by pressing the “Start Analysis” button or as part of the CDP system by the VS_CnC application via the network. Data processing is stopped either manually by pressing the “Stop Analysis” button or as part of the CDP system by the VS_CnC application via the network. While data processing is occurring, the background reference frame for the algorithm can be changed to the current frame by pressing the “Reset Background” button (or by the VS_CnC application via the network). The current video frame is displayed in the upper left corner of the UI. The background reference image is shown in the upper right corner of the UI when data acquisition is underway. The video acquisition input source and video recording codec settings are displayed for the operator below the current image. Changes can only be made in the configuration file. The indicator light in the middle of the screen turns from green to yellow to red to indicate the state of the LWVD algorithm, when running. The frame rate of video processing and the three parameters of the LWVD algorithm are indicated in the center section of the UI, when data acquisition is underway.

In DVR mode, there are three main controls for the application, which are accessed using the UI buttons on the main screen. Video recording is initiated either manually by pressing the “Start Save AVI” button or as part of the CDP system by the VS_CnC application via the network. Data processing is stopped either manually by pressing the “Stop Save AVI” button or as part of the CDP system by the VS_CnC application via the network.

For either mode, the LWVD application opens the configured video source and begins video capture immediately on application startup. The real-time video stream is shown continuously in the upper left image panel. If data processing is not occurring, it is possible to stop video acquisition and either adjust the DirectShow configuration parameters for the video source or play back a previously recorded video. The controls for these functions are located in the lower left side of the UI.

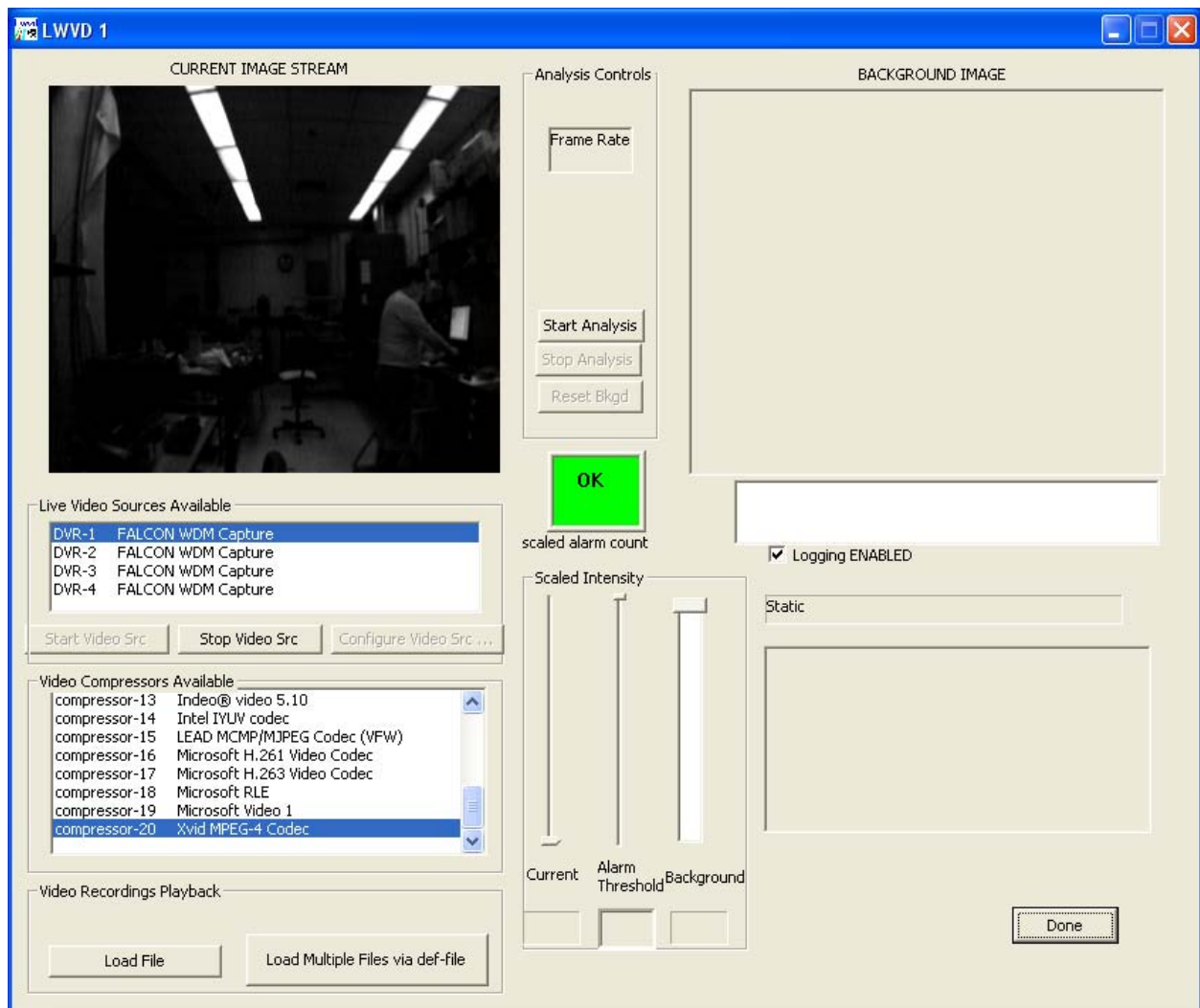

Figure 8-3 – LWVD main screen, LWVD mode, system idle, no data acquisition

8.2.1. LWVD Configuration

The configuration information for an instance of the LWVD application is stored in a configuration file (.ini). The configuration file for CDP sensor head 1, LWVD1 is shown in File Listing 8-1.

File Listing 8-1 – Annotated Version of LWVD1 Configuration File (lwvd1.ini)

```

LWVD4010101          - Root filename for data files
1                    - Source video input, range: 1 - 4
20                   - Video codec selection, range and values vary
sysdef_LWVD01_CnC1.xml - Network communications configuration definition filename(s),
                        space delimited
F:\LWVD Data Files  - Path for data file storage
0                    - Mode Selection: 0 = LWVD mode, 1 = DVR mode
LWVD 1               - Text for program title bar
LWVDmemfilemap_1    - Memory buffer for VS_Quad application
1                    - Pixel value for top edge of UI screen
70                   - Pixel value for left edge of UI screen

```

While most of these settings are self explanatory, a few require additional discussion. The easiest way to determine the proper index value for the desired video codec is to open the LWVD application and read the index number off the list of available video compressors/decompressors (codecs) in the UI. This list will show all codecs installed on the PC that can be used. If no compression is desired, index 0 should be selected. The current recommended code is the Xvid codec (v1.2.2) [12]. For the top and left values for the UI screen, the example above in File Listing 8-1 indicate top, left coordinates of (70,1), or 70 pixels to the right and one pixel down from the upper left corner of the screen. As a note, the coordinates (0,0) refer to the center of the screen, not the expected top, left corner of the screen. The network communication configuration definition for each instance is stored in an .xml file at the location indicated in the configuration file. The LWVD1 configuration file for the CDP is listed in Reference 11.

While not expected to be a routine configuration task, each video input source needs to be configured once per computer to the NTSC format. From a running, but idle instance of the LWVD application, stop video acquisition by pressing the “Stop Video Src” UI button. Then press the “Configure Video Src ...” UI button. Then select “NTSC_M” as the video source, as shown in Figure 8-4. Click “OK” to save the configuration. This function must be performed for each video source channel.

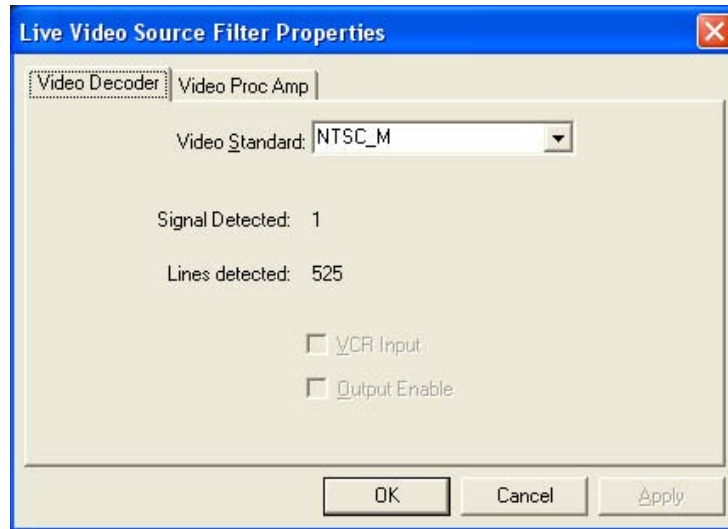

Figure 8-4 – Video Source Configuration Screen, NTSC format selected

8.2.2. LWVD Operation

The LWVD application can be launched in one of two ways: 1) launching from the command line (or batchfile) with the desired configuration file specified, or 2) by double-clicking on an associated shortcut with the desired configuration file specified in the command line arguments. If no configuration file is specified at launch, such as would happen if the executable was double-clicked on in Windows Explorer, the default configuration as specified in the default configuration file (`default.ini`) located in the binary directory is used. An example target for a shortcut to launch LWVD1 is:

```
"C:\Volume Sensor Programs\LWVD_2010_VS_Quad\LWVD.exe" lwvd1.ini
```

If the instance is properly configured, the application will launch and run in the idle state as shown in Figure 8-3 for the LWVD mode. When a 'start data processing' command is received either locally or from the VS_CnC via the network, data processing will commence with background data collection. Video recording and data logging also commence. The main screen will change to reflect the application's operating status, as shown in Figure 8-5. After 30 seconds, the background collection period is over and the reference frame is logged. The reference frame is written to disk as an image file (`.bmp`) and the luminosity threshold value for event detection is determined. All incoming data are then evaluated by the LWVD algorithm. When the algorithm detects a luminosity value above the specified event detection threshold, the algorithm moves into an event classification mode. As the algorithm status is updated, the indicator on the display changes from OK, to Pre-Alarm, and then to Alarm to indicate the evolving event condition. In Figure 8-6, the algorithm status of 'Pre-Alarm' indicates that the algorithm is in pre-alarm and that if the condition persists, an 'Alarm' condition will be reached

in the near future as shown in Figure 8-7. When a 'stop data processing' command is received either locally or via the network, data processing stops and all data files are closed.

Operation for the DVR mode is similar, except no data processing is conducted and the only data file generated is the recorded video file.

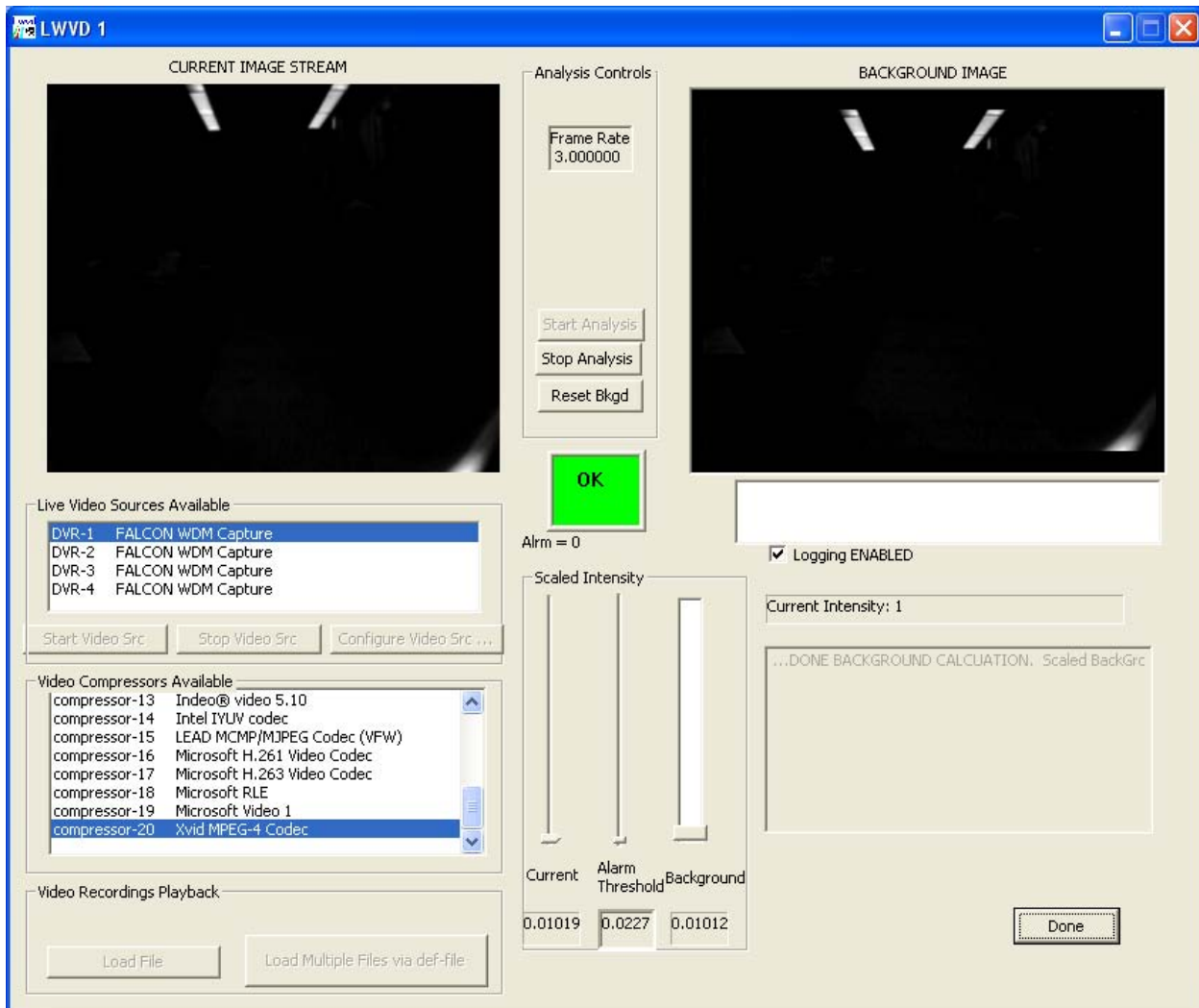

Figure 8-5 – LWVD main screen, system processing incoming data

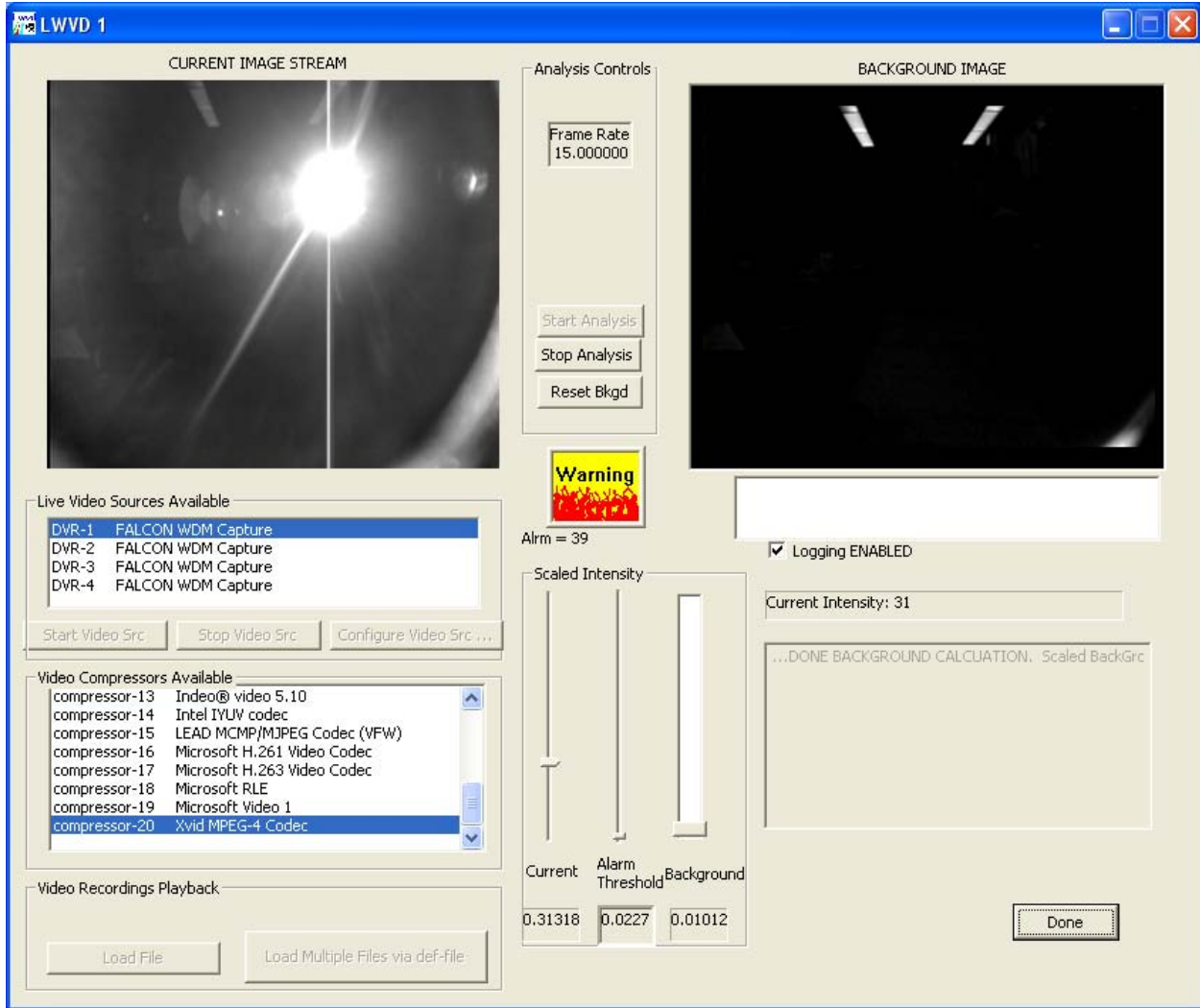

Figure 8-6 – LWVD main screen, system in FIRE pre-alarm state

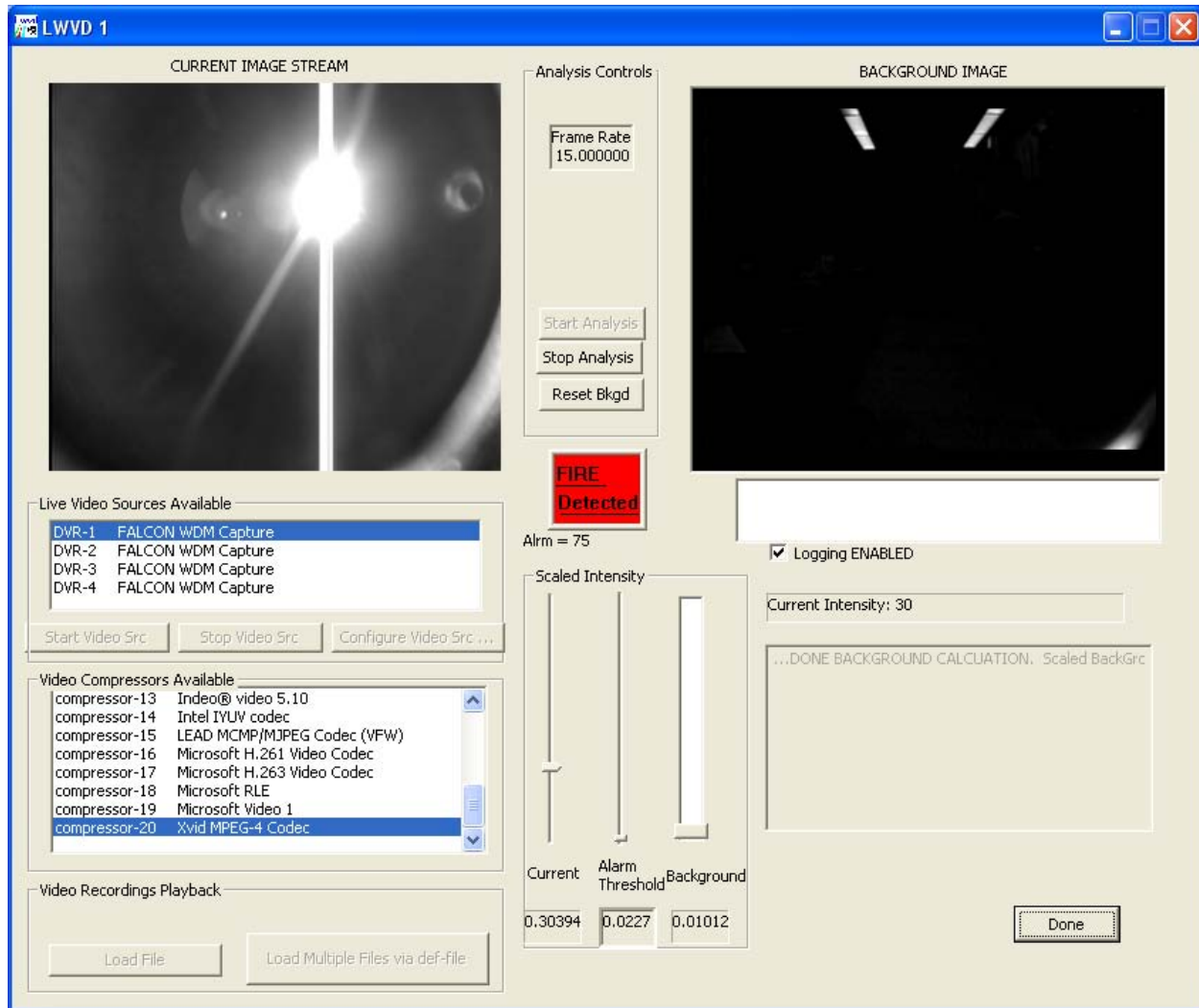

Figure 8-7 – LWVD main screen, system in a FIRE alarm state

8.2.3. LWVD Data Files

The LWVD system collects data in several data files. For the LWVD mode, there are three types of data files: 1) the data log file (*.txt, ASCII format); 2) the reference video frame used for determining the event detection threshold (*.bmp, Windows bitmap format); 3) the recorded video file (*.avi, .AVI format). For the DVR mode, there is only one data file, the recorded video file (*.avi, .AVI format).

An example data log file is given in Reference 11. For the LWVD data log files, the file naming convention is 'Prefix_LogFile_MMDDYYYY_HHmms.txt', for example 'LWVD4010101_LogFile_05282010_141328.txt'. A partial listing of an example is given in Reference 11.

The file naming conventions for the background image file and video recording files are:

```
PREFIX_BackgroundImage_MMDDYYY_HHmms_at-HHmms.bmp
```

```
PREFIX_Video_MMDDYYYY_HHmms.avi
```

The value of 'PREFIX' is determined by the first line in the configuration file. The 'MMDDYYYY_HHmms' is the time at which data processing began and is common with all data files. The 'at-HHmms' portion of the background image filename reflects the time that the background image was acquired.

9. Acoustics (ACST) Component

Routine operation of the Acoustics component for the CDP is straightforward and requires no operator intervention. For advanced configuration and usage, additional information is required and presented in this Section. The information in this Section is excerpted from Reference 13.

9.1. Acoustics Hardware and Processing Overview

Figure 9-1 shows a schematic of the acoustics hardware and processing. The microphone in the CDP sensor unit on the left of the figure is an AKG C-417 lavalier microphone commonly used by speakers making presentations.³ The signal passes along the cable to a phantom power supply, which provides 48V DC to power the microphone. The signal passes through the phantom power supply to the LynxTWO 24-bit A/D card. This card digitizes the signal and passes the results to the `EventDetector` program running on the computer. Based on the four input configuration files, the program processes the acoustic data and passes results to the Fusion Machine. The passing of results to the Fusion Machine is started and stopped by commands from the Fusion Machine software resident on the same computer.

³ The audio system can handle up to 4 sensor units.

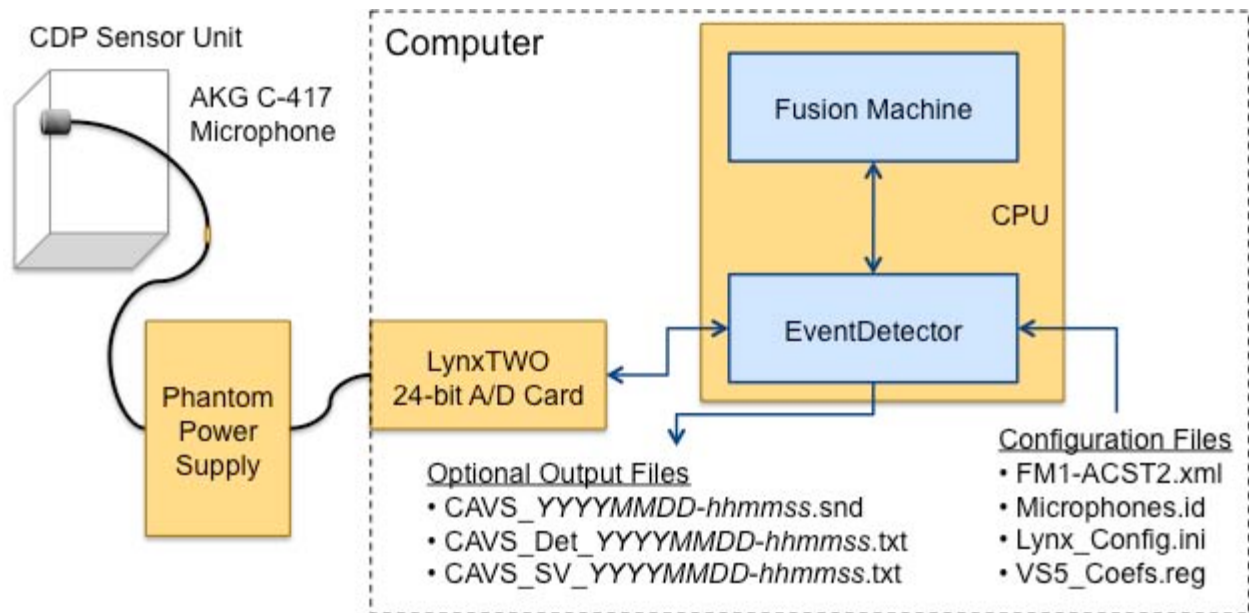

Figure 9-1 – System overview of the acoustics data acquisition and processing for the Canadian Demonstrator Prototype system.

Each CDP sensor unit, fabricated by Vibro-Meter, Inc., contains six individual sensor elements. The CDP sensor unit is shown in Figure 9-2. Two video cameras are included, one color CCTV camera (lower center), and one low-pass (NIR) filtered black and white CCTV camera (lower right). Three non-imaging, spectral-based sensor elements, mid-IR (4.3 μm , center right), UV (upper left), and NIR (1050 nm (lower right) complete the spectral sensing suite. Finally, the audio microphone is located in the small hole in the upper right corner, protruding just slightly.



Figure 9-2 – Front view of the Canadian Demonstrator Prototype Sensor Unit with the acoustics sensor in the upper right corner.

Figure 9-3 shows the back of the CDP sensor unit with the wires emerging from the hole in the rear. The acoustics wire is the thinnest one. It connects to a shorter converter cable that adapts the lavalier microphone cable to a standard XLR cable. The more robust XLR cable then runs to the computer. The XLR cable provides the 48V DC power to the microphone through the converters.⁴



Figure 9-3 – Rear view of the Canadian Demonstrator Prototype Sensor Unit with the acoustics cables and connectors in front.

Figure 9-4 shows the hardware at the computer end. The signal arrives from the sensor units on the XLR cables that are plugged into a 48V DC phantom power supply. The unit supplied is a Stewart Audio PM-4, which can power up to 4 microphones. The power supply then connects to the LynxTWO 24-bit A/D card in the computer by the cables shown in the figure. The card provided is the A model and has eight channels, four inputs and four outputs.⁵

Once inside the computer and converted to digital representation by the A/D card, the data are passed to the `EventDetector` program for analysis. This program analyzes the signal characteristics on an ongoing basis and provides results to the Fusion Machine for further analysis and handling.

⁴ From experience, the XLR can safely be run at least 50 ft with no problems. An upper limit for XLR cable length has not been determined.

⁵ There are B and C models that differ by varying the number of input and output channels, 2/6 and 6/2.

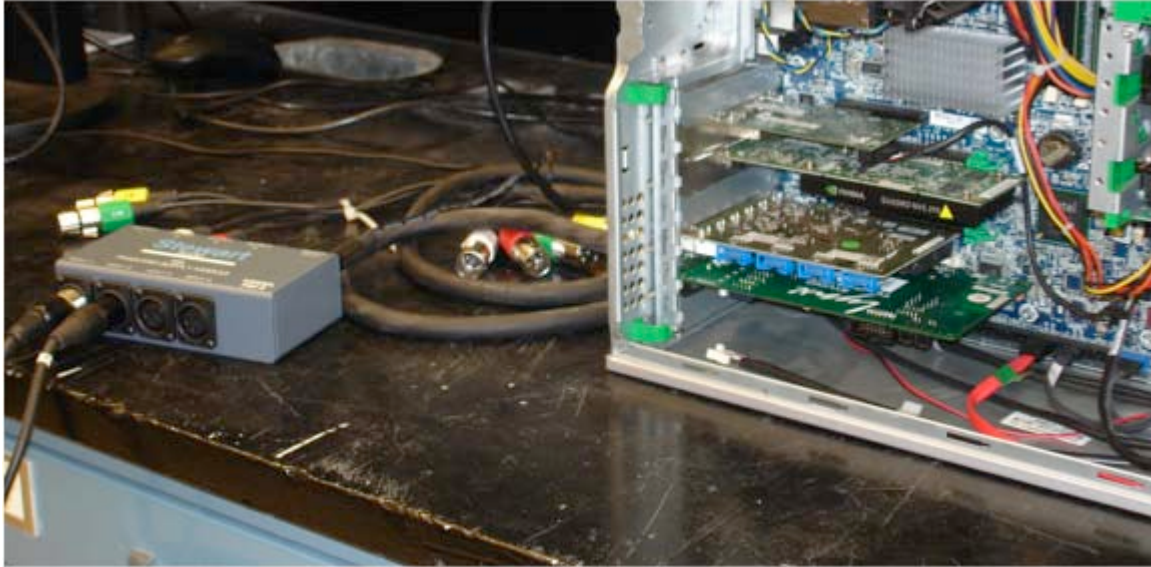

Figure 9-4 – Computer connections showing the acoustics A/D card (on bottom), connecting cables, and the phantom power supply.

9.2. Acoustics Processing Software and Control Files

9.2.1. Acoustics Processing

The principal component of the acoustic processing software is the `EventDetector` program. The acoustics processing is centered on a linear discriminant algorithm used to classify noise according to the characteristics of the audio spectrum. This program monitors the ambient noise in a compartment and when sounds typical of an event, such as water falling are detected, it reports a pipe rupture or other event based on the noise detected. This is done through two types of data passed to the Fusion Machine, channel data and alarm status for each event. The channel data represent an estimate of the probability of an event. As an event persists, the alarm level is continually raised until sometime after 3 seconds it is considered fully set and an event is formally considered detected. Table 9-1 lists the different types of events looked for by the acoustic processing software. The abbreviation column is used in real-time monitoring of the processing in a terminal window.

Table 9-1 – Audio Events and Alarms

Event	Abbreviation	Alarm Type
Sensor Overload	O	Event
Background Noise	N	Background
Water	W	Pipe Rupture
Mist	M	Event
Gas Leak	G	Event
Torch	T	Nuisance
Grinding	R	Nuisance
Welding	L	Nuisance
Engine	E	Nuisance
People	P	Nuisance
Activity	H	Nuisance

The first event, sensor overload, is processed before the others. The channel data and alarm status for this event represent the percentage of the data believed to be overloaded. Full scale is 1% of the time series points on the channel. This alarm is set faster than the others, activating immediately if the 1% threshold is reached. If this condition is observed all other alarms must be considered suspect. After testing for overloads, the program then Fourier transforms the data in 0.2 s chunks, overlapping the previous chunk by 0.1 s or 50%. Once every second, based on the previous 5 s of results, it calculates 270 parameters; mean levels in 200 Hz bands, standard deviations, skew, slopes, number of lines, transients, and A-weighted mean level, standard deviation, and skew. These parameters are normalized and then multiplied by the regression coefficients to obtain channel measures that are then converted to probabilities and the alarm state raised or lowered according to the probabilities. There is a separate algorithm, based on the high frequency slope of the spectra, looking for water events. If this algorithm detects something it will increase the probability of a water event resulting in a faster detection.

Background noise, the null state, is based on the last 3 minutes of data. As such, when running tests it is desirable to give the processing 3 minutes to start up. The system is set up so that if an event is not found in a stable noise environment the background noise characterization will adjust to the new noise environment. This reliably handled changes in ventilation strength aboard the *ex-USS SHADWELL*.

State vector data, composed of channel data and alarm data, are not sent to the Fusion Machine until specifically requested. `EventDetector` begins running immediately when the program is started and thus a noise background level may be well established before the Fusion Machine requests the state vector data.

Obviously, an event is only detectable if its significant characteristics rise above the background noise. Loud enough noise can mask all events.

9.2.2. Software and Control Files

The acoustics processing software is located in the Acoustic directory currently set as 'C:\Volume Sensor Programs\ACST\'. Within this directory are 8 files, listed in Table 9-2, necessary for the proper function of the acoustic processing software. Of these eight files, the first three files listed in Table 9-2 are the code executed during the running of the audio processing. The fourth file is a temporary file used in communications with the Fusion Machine. The last four files are text files, which under certain circumstances may need to be edited. However, only one of these, `Microphones.id`, should be edited under normal circumstances.

Table 9-2 – Acoustic Directory Files

<code>acst_server.exe</code>	Talks to the Fusion Machine to receive start, stop, status commands and to send the data messages.
<code>Audio_Capture.dll</code>	Library containing the routines to start, read and close data acquisition.
<code>EventDetector.exe</code>	Main acoustic processing program.
<code>input_command_log.txt</code>	Used to temporarily store file names of Fusion Machine commands until <code>EventDetector.exe</code> can process them.
<code>Lynx_Config.ini</code>	LynxTWO configuration file, which contains only one parameter to set a debug mode. See listing in Reference 13.
<code>FM1-ACST2.xml</code>	System definition file. See discussion below and listing in Reference 13.
<code>Microphones.id</code>	Sensor identification file. See discussion and listing below.
<code>VS5_Coefs.reg</code>	Regression coefficients file. See discussion below and listing in Reference 13.

`Lynx_Config.ini` is the configuration file for the LynxTWO audio card. All features of the LynxTWO software are hardwired, except for a debugging option available in this file. The user should not change this file unless they have spent the time to become familiar with the software used to run the LynxTWO data acquisition card. `FM1-ASCT2.xml` is the system definition file. This file defines the interface to the Fusion Machine and should be changed only in coordination with that program. Specifically, it contains port and IP address information that may need to be changed when setting up. This file formally defines the state vectors containing the channel data and alarm status for each type of event. The file contains the information for the maximum number of sensors that can be processed by `EventDetector`, which is 4.

`Microphones.id` is the sensor identification file. This file tells the audio processing what sensors are available. File Listing 9-1 shows the contents of the file as shipped. The format is very simple; the first line is the number of channels and must be an integer value between 1 and 4. Then on the next 1 to 4 lines are listed the sensor type. Currently they are all set to `CAVS_Box`. Finally, an additional line may be added to request files to be put out with the raw acoustic data and processing results. This option is the subject of Section 9.4.

File Listing 9-1 – Sensor Identification File, `Microphones.id`

```
3,
CAVS_Box
CAVS_Box
CAVS_Box
```

The other sensor options available are provided in Table 9-3. The Shure MX-393 and MX-202 microphones were used extensively during developmental work. The Shure KSM-141 is a studio-grade microphone with wide dynamic range and flat response and was used as a reference to establish the sensitivity and frequency response of the CDP sensor unit. System sensitivity and frequency response factors for these microphones are defined in the software. Using other sensors will require modification of the software. The microphone in the CDP sensor unit is the AKG C-147L. The sensitivity and frequency response have been experimentally determined and included in the software to adjust for the presence of the box around the microphone.

Table 9-3 – Valid Sensor Options

Sensor Names	Sensor Description
AKG_C-577-WR	AKG water-resistant lavalier microphone
AKG_C-147L	AKG lavalier microphone
CAVS_Box	CDP Advanced Volume Sensor unit with AKG C-147L inside
Shure_KSM-141	Shure extended-range, studio microphone
Shure_MX-183-0	Shure wired lavalier microphone
Shure_MX-202-0	Shure hanging microphone used for choirs and performance groups
Shure_MX-393-0	Shure surface mounted, boundary effect, microphone

The final file, `vs5_Coefs.reg`, is the regression coefficients file. It includes parameters and scalings necessary for the acoustic processing to work. It is used to calculate probabilities of an event having occurred. This file should not be modified.

9.3. Acoustic Installation and Operating Instructions

9.3.1. Hardware Installation Instructions

Refer to Figure 9-3 and Figure 9-4 as indicated.

1. Verify that the LynxTWO card is properly seated in the computer. (Figure 9-4) If it is not installed, refer to the LynxTWO User's Manual or Quick Start Guide, Refs. [14 & 15], for installation instructions.

2. Connect the Lynx Audio cable (Lynx part, CBL-L2AUDIO) to the audio port and secure it. (Figure 9-4)
3. Connect the analog-in cables labeled, “IN-1” and “IN-2” of the audio cable to the Stewart phantom power supply. (Figure 9-4) If more channels are being used connect cables “IN-3” and “IN-4” as needed.
4. Connect the appropriate XLR microphone cables to the phantom power unit and string each to the appropriate CDP unit. (Figure 9-4) Verify that the proper unit is being connected to the proper audio channel. Generally, CDP unit 1 to audio “IN-1”, etc.
5. Attach the XLR-lavalier microphone converter cable to the XLR cable and the small cable from the CDP unit. (Figure 9-3)
6. Plug the power supply for the Stewart phantom power supply into a standard wall socket and into the phantom power unit. (Figure 9-4)

9.3.2. Software Installation and Operating Instructions

During normal operation the functioning of the acoustic system is automatic and the user needs only to verify the presence of the configuration files and that they contain the proper contents as described in Section 9.2. In particular, verify that `Microphones.id` contains the proper contents.

The acoustic software will launch automatically when the command file is used to start all components of the CDP Volume Sensor system. At this time an acoustics display window will appear that monitors the status of the acoustic processing. The window will update at 1 s intervals with the noise level (dB_A) and the alarm status for each event on a single line for all channels. When an alarm is building towards being set (value of 1.00), it is presented as a lower case letter for which the abbreviation can be found in Table 9-1. When an alarm is reached it appears as an upper case letter. When the alarm state is essentially zero a decimal point is substituted for the letter. It will not start sending state vector information until instructed to by a start command received from the command and control component of the Fusion Machine software. It will stop sending state vector information when a stop command is received, but the software will continue to run. Both of these commands will be displayed in the display window when received. It is recommended that the acoustics software be stopped by typing a “q” in the acoustics display window.

9.4. Testing Mode

As noted in Section 9.2, a testing mode can be initiated by changing the `Microphones.id` file to include a final line listing an output directory for storing audio data files. An example is provided in File Listing 9-2. The directory shown is a directory used during system testing, but any valid directory is acceptable. When the final line exists, `EventDetector` will create 3

output files; a sound file containing the raw data with a header, a state vector file containing the channel data and alarm status for each event type and sensor, and a detections file containing the first time each alarm triggered. These files are only created when data are requested by the Fusion Machine and are best used when running a series of tests with `EventDetector` not sending data between events.

NOTE: It is important to not leave the testing mode active under normal operating conditions as the sound and state vector files can become excessively large.

File Listing 9-2 – Sensor Identification File, `Microphones.id`, with Testing Mode Activated

```
3,
CAVS_Box
CAVS_Box
CAVS_Box
F:\ACST Data Files\
```

The sound data file is labeled in the format `CAVS_YYYYMMDD-hhmmss.snd`, where year, month, day, hour, minutes, and seconds of the start time of the file. In each file will be a header with information on the sampling rate, number of channels and time points and the system gain applied to the data. The latter is the system gain for the first channel. The data have not been corrected for the frequency response. Thus the data for the 2nd through 4th channels will need to be corrected for system gain if they are not the same type of sensor as the first channel. All channels will need to be corrected for the frequency response of the sensor.

The second file is the state vector file, labeled `CAVS_SV_YYYYMMDD-hhmmss.txt`. This is a text file labeled with the same date-time string as the sound file. This file contains the contents of the state vectors sent to the Fusion Machine every second while running. The structure is as follows:

1. Time in `hh:mm:ss.sss` format, hours, minutes and seconds.
2. Noise level in dB_A units for channel 1.
3. Overload alarm status for channel 1.
4. Channel data and alarm status for each of the final 10 events in Table 9-1 for channel 1. 20 positions.
5. Noise level, overload alarm status and event status, channel data and alarm, for each of the remaining channels. 22 positions for each channel, repeating items 2-4.

The third file produced is the detections file, labeled `CAVS_Det_YYYYMMDD-hhmmss.txt`. This is a text file labeled with the same date-time string as the sound and state vector files. This file contains a single line with the times of the detections for each event and channel on a single line. The format is date information followed by time for the events in each channel. Note that the second time is the noise time and should be the time that processing was started for the event. This file is only written if the event is properly terminated with a stop command.

10. SigniFire Machine Vision (VID) Component

Routine operation of the *SigniFire* VID component for the CDP is straightforward and requires no operator intervention. For advanced configuration and usage, additional information is required and is presented in this Section. The information in this Section is excerpted for Reference 16.

10.1. SigniFire IP Physical Configuration

The core of the *SigniFire* system is the *SigniFire IP* network camera, as shown in Figure 10-1.

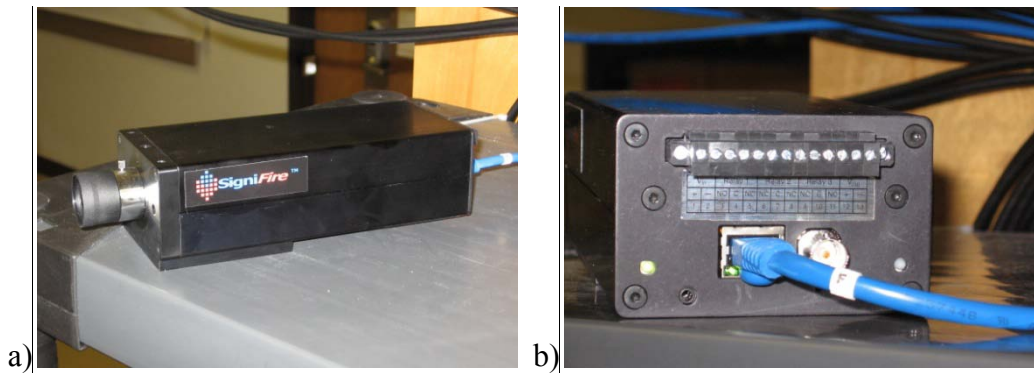

Figure 10-1 – *SigniFire IP* Camera a) $\frac{3}{4}$ profile view b) rear view

Details on the specifications and configuration of the *SigniFire IP* camera are available in Reference 17. Each camera is provided with an adjustable focal-length lens. The cameras are powered using Power-over-Ethernet (PoE) or optionally from an external 12 VDC supply. PoE is used for the CDP implementation. The configuration and address information for the two cameras provided with the CDP are listed in Table 10-1.

Table 10-1 – *SigniFire IP* Camera Details

	Camera 1	Camera 2
Tag Number	001485	001484
Camera S/N	XD0000000345	XD0000000394
MAC address	00-1B-5A-00-01-59	00-1B-5A-00-01-8A
Part Number	<i>SigniFire IP</i> TM -01	<i>SigniFire IP</i> TM -01
SigniFire IP S/N	IP 00197	IP 00214
Software Version	1.842	1.842
Local IP address	192.168.0.101	192.168.0.102

Camera configuration (*e.g.* configuring network settings) is done using the built-in web interface found in each camera, found at '<http://192.168.0.101/admin>' for CDP Camera #1.

Administrative privileges are required for configuration changes. The user name and passwords are 'admin' and 'axonx' respectively. An example of the configuration screen for CDP Camera

#1 is shown in Figure 10-2. Please refer to Sections 3.3 and 3.5 of Reference 17 for further details.

SigniFire™

General Settings

Changes to the network and camera settings require the camera to be restarted before they take effect.

Network Settings

Mode	Static IP
IP Address	192.168.0.101
Subnet Mask	255.255.255.0
Gateway	192.168.0.1
DNS Server	192.168.0.1
Domain Name	axonx.com

Camera Settings

Camera Name	SigniFire IP
Flicker Control	Manual 60Hz
Frame Time	60
Composite Format	NTSC
Overlay	<input checked="" type="radio"/> On <input type="radio"/> Off

Figure 10-2 – General Settings page on CDP Camera #1's internal webserver.

The NVR provided as part of the system coordinates operation and data logging for the *SigniFire IP* cameras. The NVR has two network interface cards (NICs). The first NIC (#1) is configured for the same subnet as the *SigniFire IP* cameras (192.168.0.XXX) and is used for communication with the cameras. A second NIC (#2) is provided for communication with an exterior network, but it is not currently used in the CDP implementation. The NVR NIC1 IP address is 192.168.0.10. As currently configured, all CDP network devices are operating on the 192.168.0.XXX subnet and share a single network switch. The NVR is built on a rack-mount PC system running Windows XP Professional, Service Pack 3. The *SigniFire IP* server software

installed is version 4.1.3651.29332. The main user interface, *SpyderGuard IP*, is currently version 4.1.3678.31441⁶.

10.2. System Startup

Once installed and properly configured, the *SigniFire* system is designed for long term operation. If the NVR and *SigniFire* server software have been properly configured since the last power cycle, system startup is straightforward with no required configuration.

Briefly, to start up the system, there are two applications that need to be started. First the *SpyderGuard IP* application is launched using the previously stored configuration. The configuration file (NRL 2 Channels.axf) is located on the NVR desktop. Double-click on the configuration file to launch *SpyderGuard IP*. Second, the VSCS.Bridge middleware application is launched using the icon on the NVR desktop. Once both systems have started correctly, the main screen of each application will resemble those shown in Figure 10-3 and Figure 10-4.

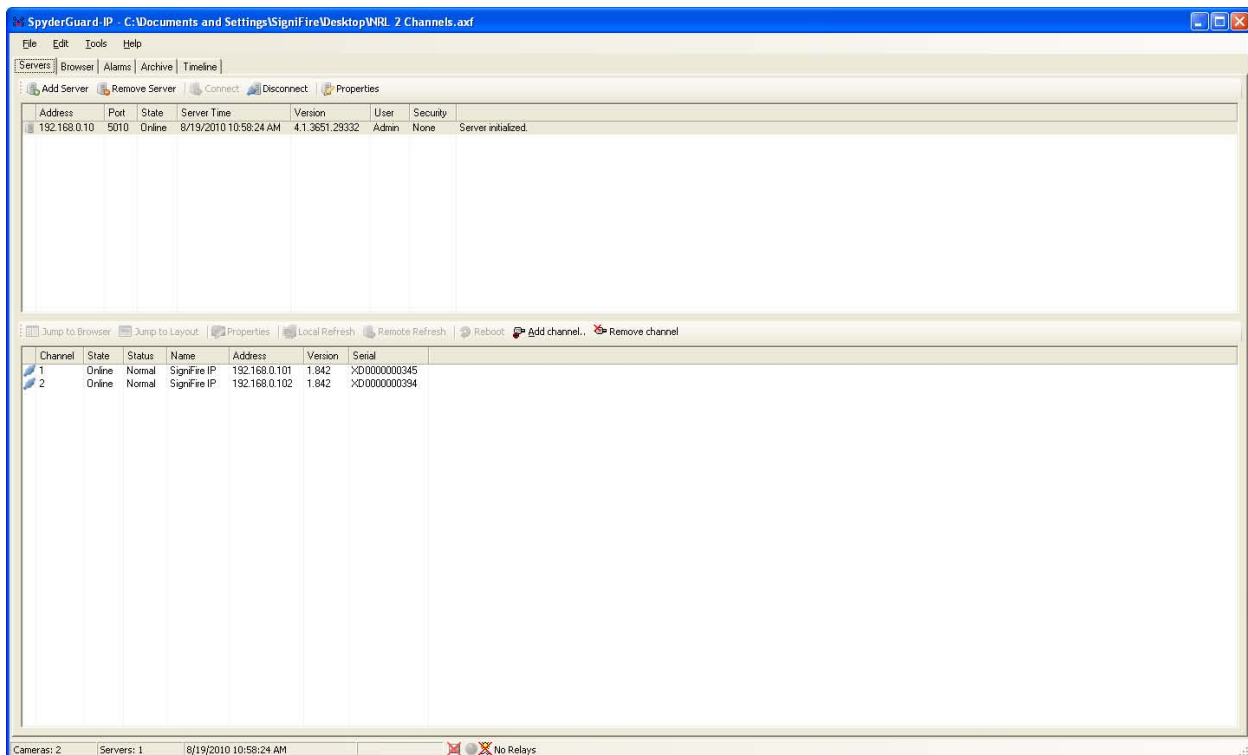

Figure 10-3 – *SpyderGuard IP*, Server Tab, with Cameras Loaded

⁶ The *SigniFire* software was updated by axonX Fike during the shakedown testing of the CDP on ex-USS Shadwell in September, 2010. Application version numbers may have been updated at that time.

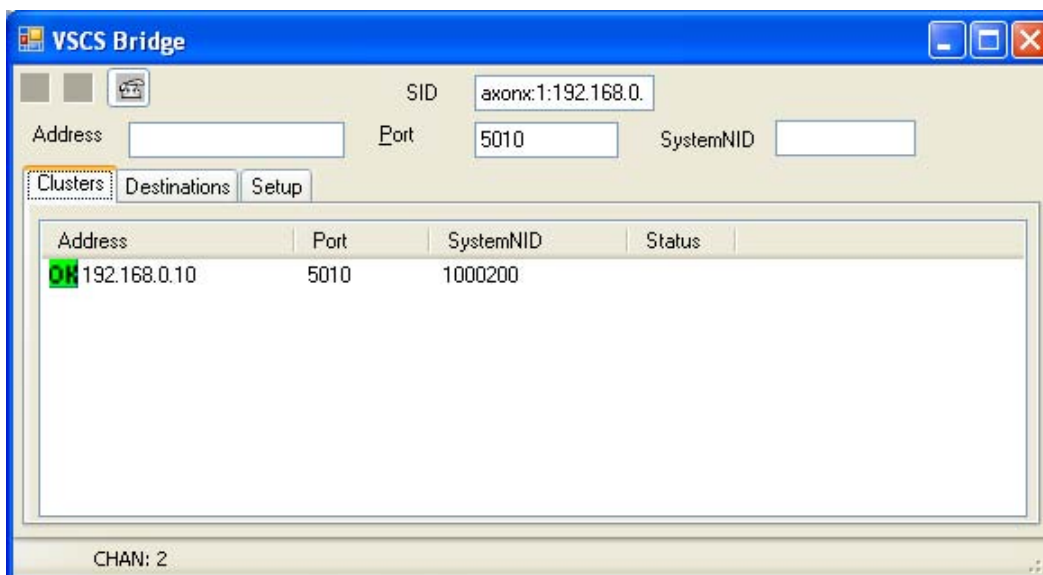

Figure 10-4 – VSCS.Bridge, Cluster Tab

10.2.1. *SpyderGuard IP* Startup

If the *SigniFire* server has not been properly configured since the NVR was last power cycled, the system configuration must be loaded as described in this section. Further details on the *SpyderGuard IP* software is available in Reference 18. Insure that the provided PoE Ethernet switch and *SigniFire IP* network cameras are plugged in and powered. If necessary, turn on the NVR PC and allow the system to boot. Login as the user “*SigniFire*”. No password is required. Allow the system several minutes for all OS and *SigniFire* services to completely start up. Then launch the *SpyderGuard IP* application by double-clicking on the configuration file stored on the system desktop (NRL 2 Channels.axf). The contents of this configuration file are given in Reference 16.

Once the application has launched and initialized, the *SpyderGuard IP* user interface should appear as shown in Figure 10-5 and Figure 10-6. While the configuration file has been loaded (as can be seen by the correct camera configuration shown in Figure 10-6), the server is not properly connected to the cameras. To initiate the connections, select the indicated server (address 192.168.0.10) on the Server Tab as shown in Figure 10-7 and select the “Add Channel” button in the middle of the screen. The “Select Available Camera” window will open, as shown in Figure 10-8. Select both cameras as shown and press the “OK” button. This step may take several minutes to properly initialize. The system is properly configured when the number of cameras listed in the left side of the status bar (lower left of screen) reads “Cameras: 2”. When complete, the Cameras will be shown in the Server and Browser Tabs as shown in Figure 10-3 and Figure 10-9. The *SigniFire IP* system is now properly operating.

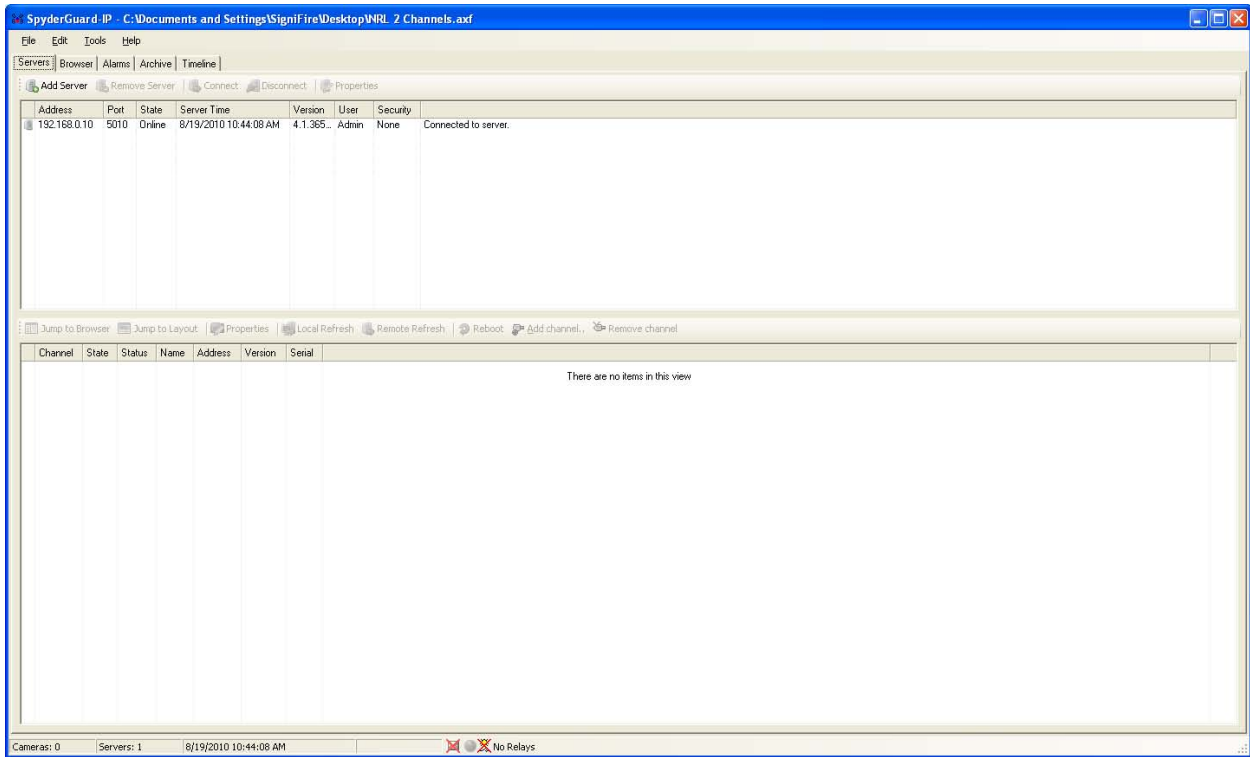

Figure 10-5 – *SpyderGuard IP* on Application Start, Server Tab

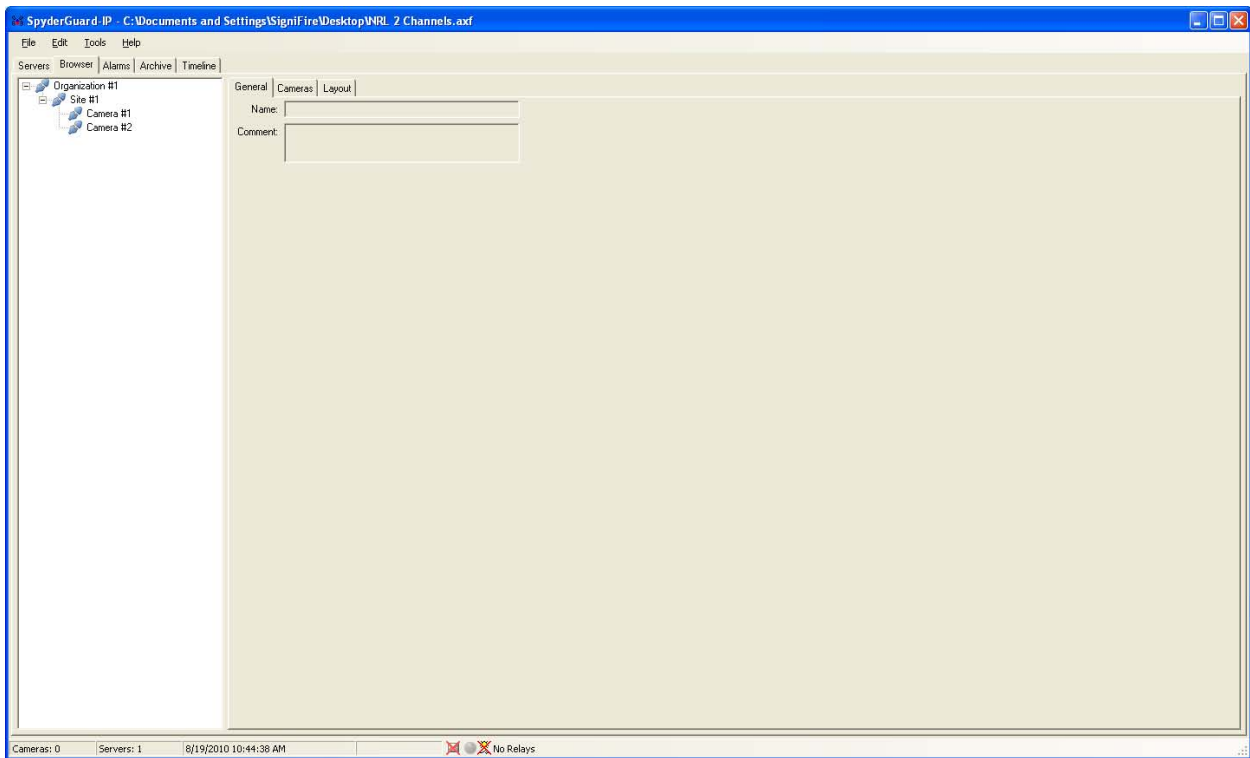

Figure 10-6 – *SpyderGuard IP* on Application Start, Browser Tab

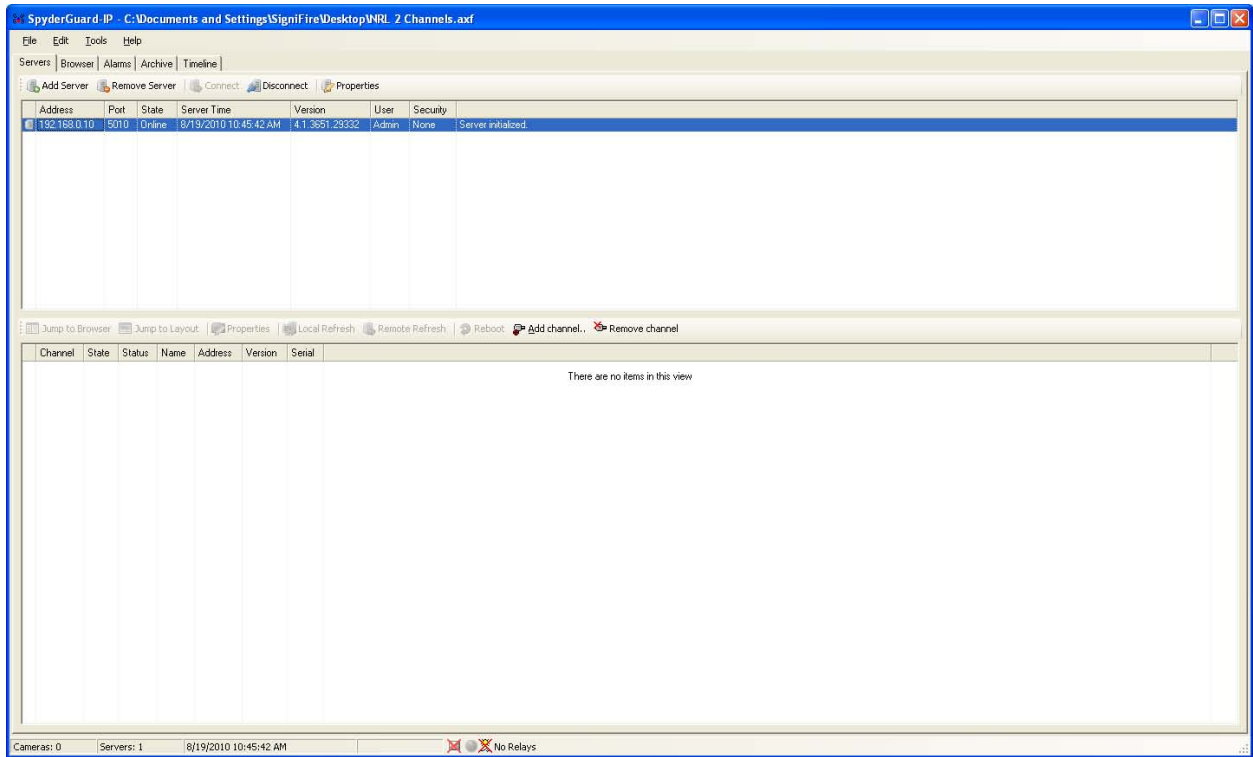

Figure 10-7 – *SpyderGuard IP*, Server Tab with Server Selected

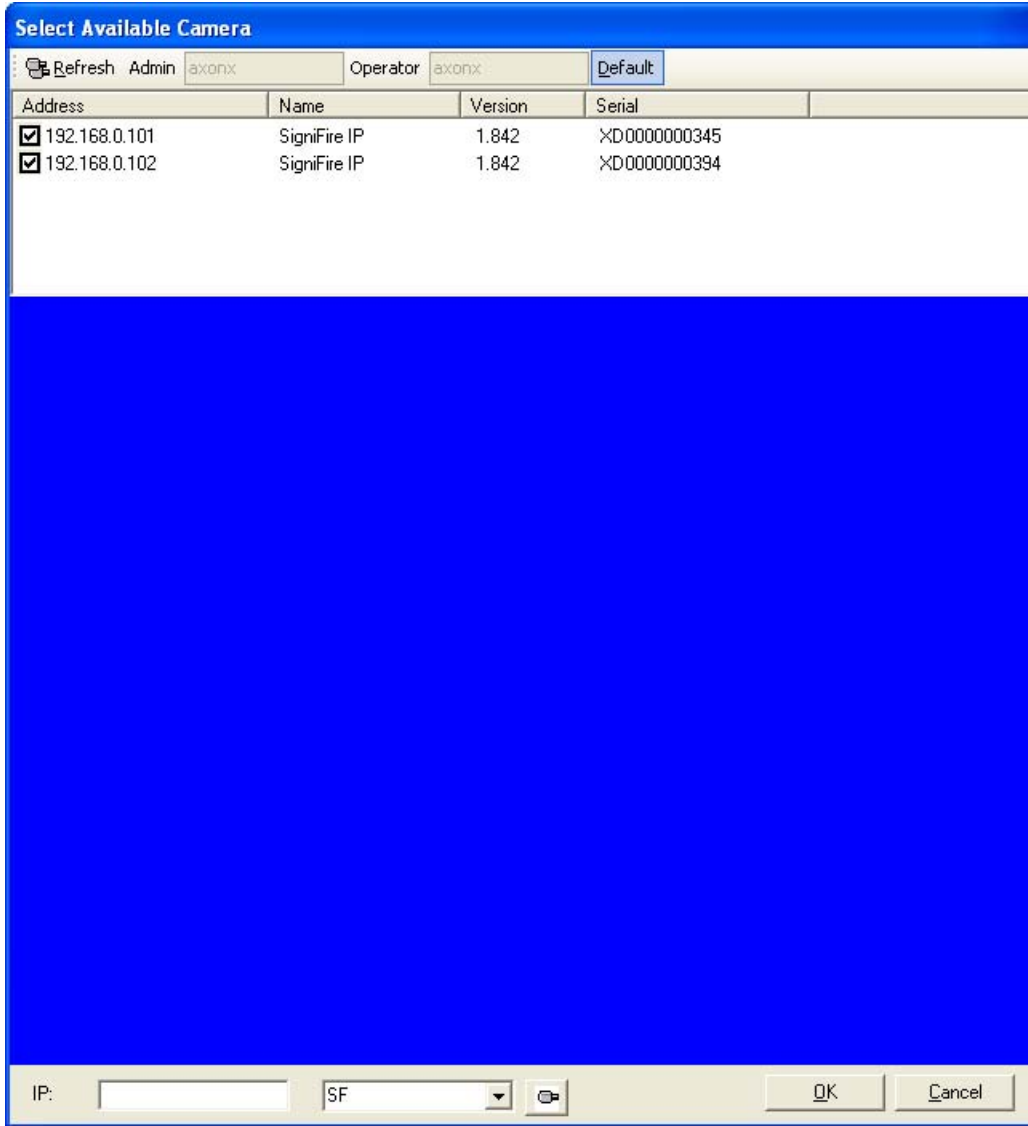

Figure 10-8 – “Select Available Camera” Window

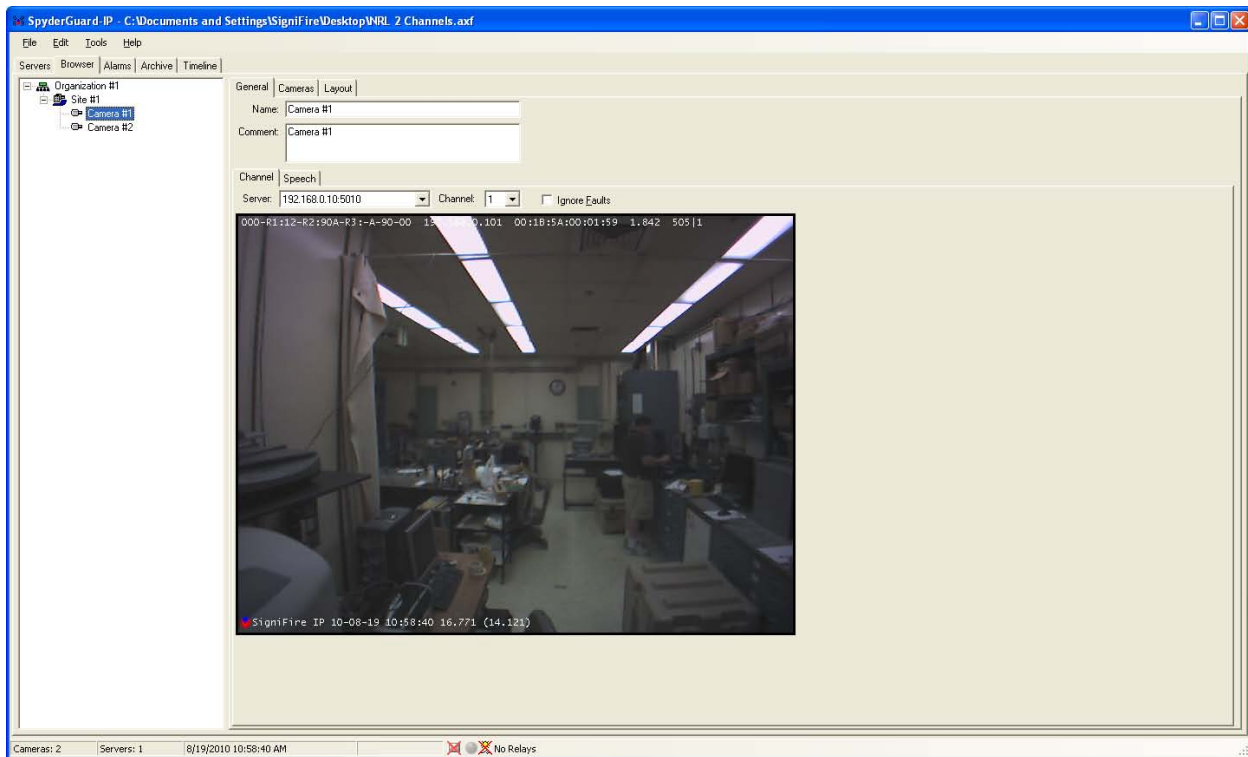

Figure 10-9 – *SpyderGuard IP*, Browser Tab, with Camera #1 Selected

10.2.2. VSCS.Bridge Startup

The VSCS.Bridge application provides the connection between the *SigniFire* system and the CDP VS_CnC application. To launch the application, double click on the VSCS.Bridge icon on the system desktop after the *SpyderGuard IP* application is running and configured. The application will open and after a brief delay, indicate its operation state as shown in Figure 10-4 by the presence of the green “OK” box. The VSCS.Bridge application is configured via information entered in a series of tabs shown in Figure 10-4, Figure 10-10, and Figure 10-11 rather than via the standard .xml files used by the rest of the CDP system. The corresponding .xml configuration file loaded by the VS_CnC on the system control PC must match the settings given in the VSCS.Bridge application.

On the “Clusters” tab, as shown in Figure 10-4, the information to form the VSCS string ID (SID) are shown. In this case, the IP address of the computer running the VSCS.Bridge application (192.168.0.10) and the system numerical ID (NID, 1) are entered. Also the TCP port used by the *SigniFire IP* / VSCS.Bridge pair is entered here (5010). This TCP port is not to be confused with the UDP port used for VSCS communication that is specified on the “Destinations” tab. Changes are committed by pressing the [+] button.

On the “Destinations” tab, as shown in Figure 10-10, the IP address and receiving UDP port for the VS_CnC application is listed. In this case, the VS_CnC is running on the system control PC

which has the IP address 192.168.0.1. The VS_CnC is configured to expect communication from the SigniFire System on UDP port 50100. The UDP port (50100) used for communication with the VS_CnC should not be confused with the TCP port (5010) used for VSCS.Bridge to communicate with *SigniFire IP*, even though both port numbers appear on the “Destinations” Tab.

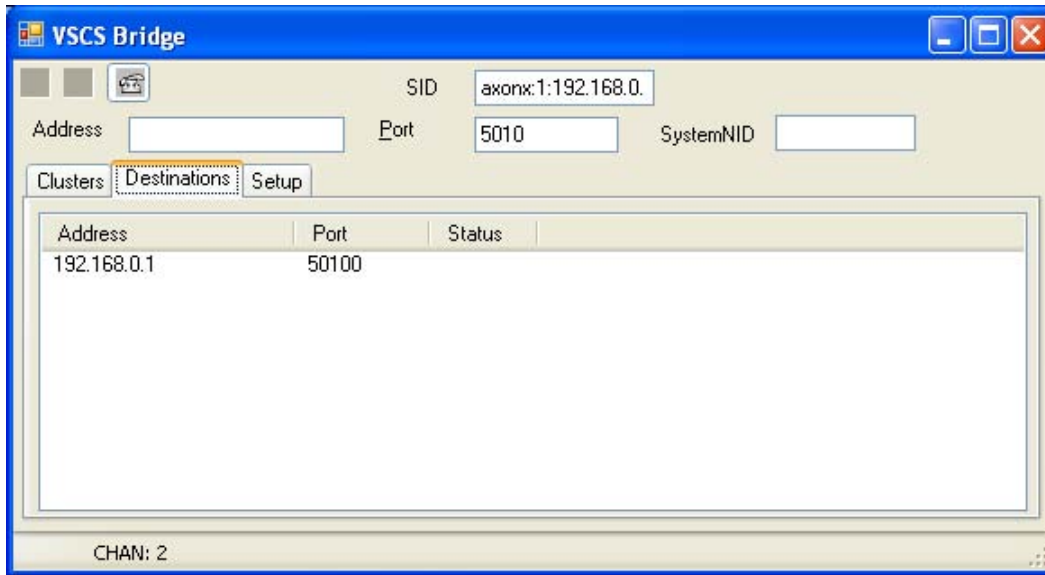

Figure 10-10 – VSCS.Bridge, Destination Tab.

On the final tab, “Setup”, the UDP port for incoming commands from the VS_CnC and the NIC to use are selected. In this case, they are “10200” and the NIC assigned the IP address 192.168.0.10, as shown. The *SigniFire* system is now properly configured to run and communicate with the CDP’s CnC and data fusion software. All configuration values are stored and will be correctly populated from run to run.

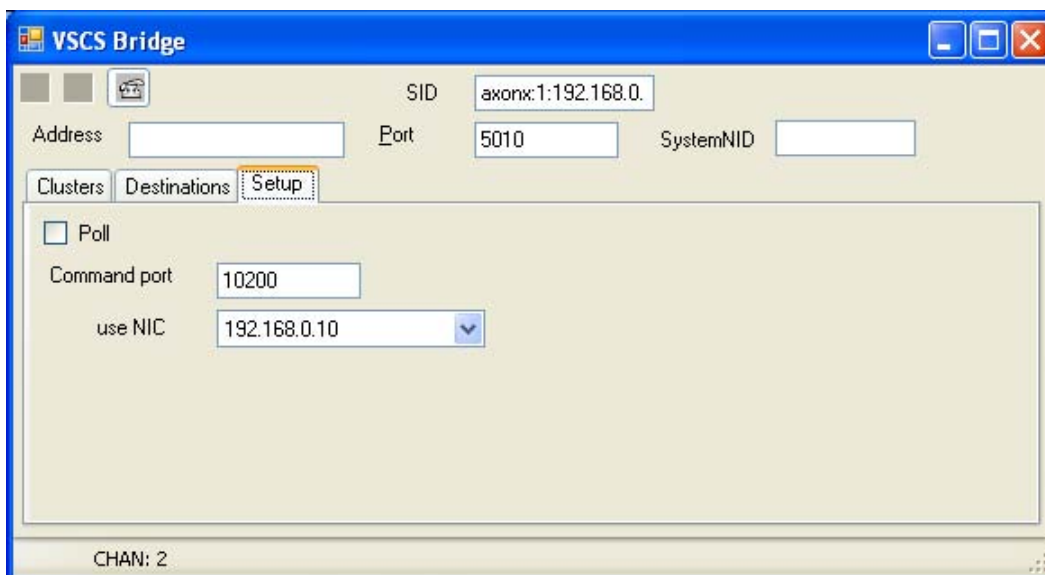

Figure 10-11 – VSCS.Bridge, Setup Tab

10.2.3. SigniFire IP Camera Zone Configuration

Due to the sensitivity of the *SigniFire IP* camera event detection algorithms, it is possible to generate false alarms, especially smoke events, from routine events occurring in the space such as people moving around in the field of view of the camera. As general practice, exclusion zones are applied very liberally in SigniFire installations to prevent events which can clearly not be smoke or fire from causing false alarms. Inclusion and exclusion zones can be defined for each camera using either the camera's internal web server or, preferably the *SpyderGuard IP* GUI. Details are provided in the supplied References 17 (Section 3.5) and 18 (Section 5.1). An example configuration is shown in Figure 10-12 using the *SpyderGuard IP* GUI [19].

In the example, the entire bottom of the image is blocked where people may gather. In addition, zones are applied to cover areas where light effects may cause the alarms. These areas can be identified after letting the camera run for some time and reviewing any generated false alarms. The zone editor has a built-in feature [Select..] button to playback the recorded alarms to simplify the task of assigning zones. This method is effective because zones are not simply masking the image as was the case in earlier generations of the *SigniFire* system. The camera applies detection algorithms to the video and will track plumes no matter how zones are set. The system will not alarm if an entire plume is contained inside of at least one of blocking zone. If detection zones are being used, then the system will alarm as soon as the plume crosses into at least one of the detecting zones. Real smoke is impossible to contain and it always breaks out from (to) the zone.

The configuration of zones is an installation-specific activity that depends on the camera field of view, so this process should be followed for each installed camera.

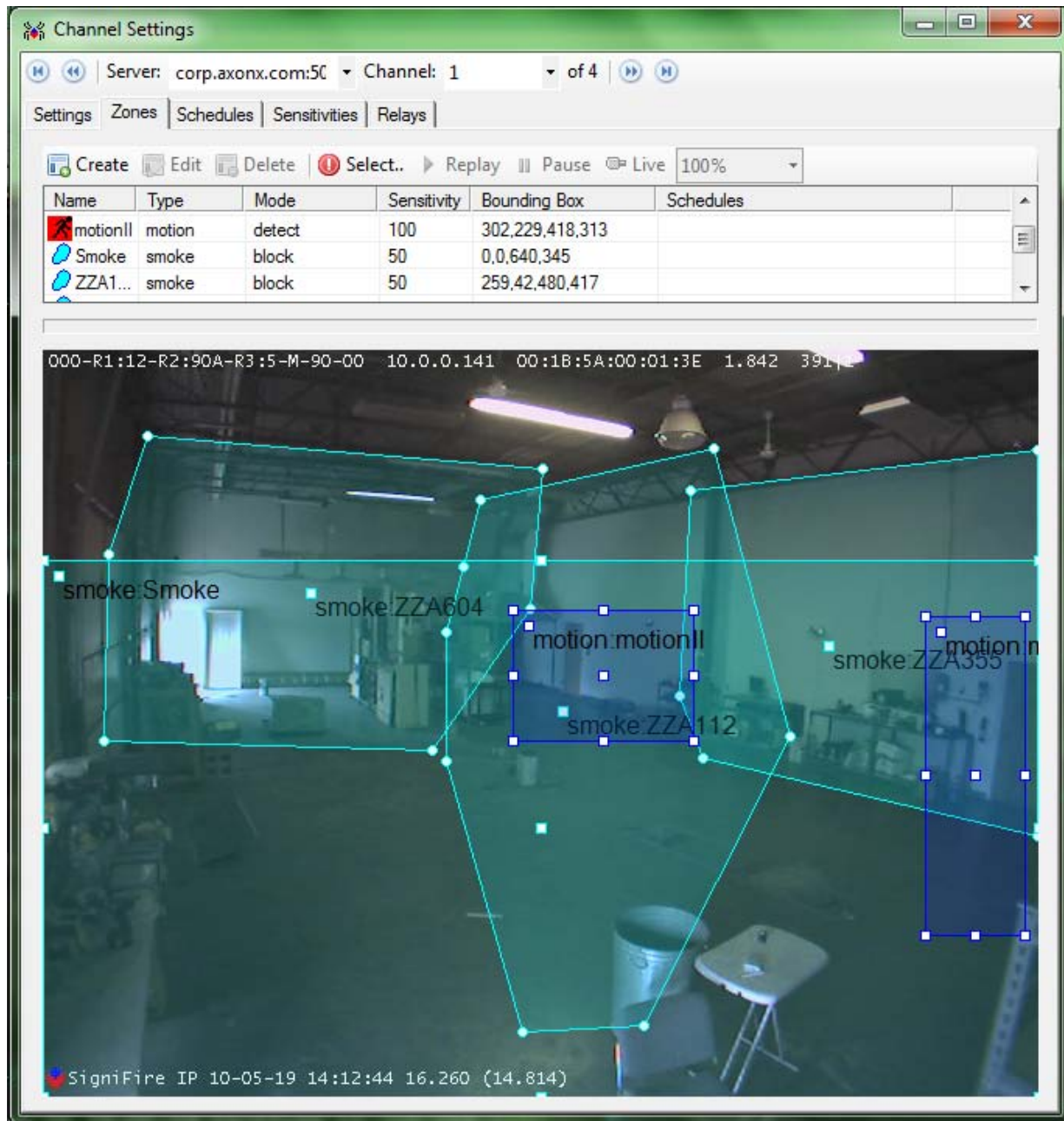

Figure 10-12 – *SigniFire* Event Detection Zones

10.3. Video Recording

The *SigniFire* NVR provides the facility for recording the video that is collected by the *SigniFire IP* cameras. The NVR is recording all the input videos from all channels continuously in a circular storage buffer along with any event information. Old video and events are eventually purged as they reach the end of the buffer. How long video is stored depends on amount of disk space allocated for storage, the number of connected cameras, image size, etc. Please refer to Reference 20 for further details.

The operator can review and replay logged video and events from the circular storage buffer using the Timeline tab in the *SpyderGuard IP* GUI. Individual events and arbitrary sections of time can be selected and exported from the buffer for permanent archive purposes. Video is stored in a vendor-specific format (*.axm) using a proprietary video codec⁷. Please refer to Section 5.5, “Reviewing Video Recordings in the Timeline Tab” of Reference 18 for further details. The *Movie Player* utility program is also provided on the NVR to convert .AXM files to the standard .AVI file format.

11. Volume Sensor Quad-View (VS_Quad) Software

Routine operation of the VS_Quad software for the CDP is straightforward and requires no operator intervention. For advanced configuration and usage, additional information is required and presented in this Section. The information in this Section is excerpted for Reference 21.

11.1. VS_Quad Software

The VS_Quad application is designed to be run after one or more instances of the LWVD application has been started. The application displays the video streams transferred from the LWVD instances with predefined labels, as directed by the configuration file. No processing of the video streams is performed by the VS_Quad application. The VS_Quad software has no user interface (GUI) other than the video display, but is useful for monitoring the LWVD and VID video streams in real time. The configuration and operation of the software is briefly described here.

Upon startup, the VS_Quad application is displayed, as shown in Figure 11-1. As shown, each video camera in the two active CDP Sensor Heads is monitored by an instance of the LWVD application, for a total of two instances per Sensor Head and four instances total. Each instance of the LWVD application then forwards the video information to the VS_Quad application via a local memory buffer.

⁷ The video codec installer is available on the NVR in the archive file, *axmclip.zip*.

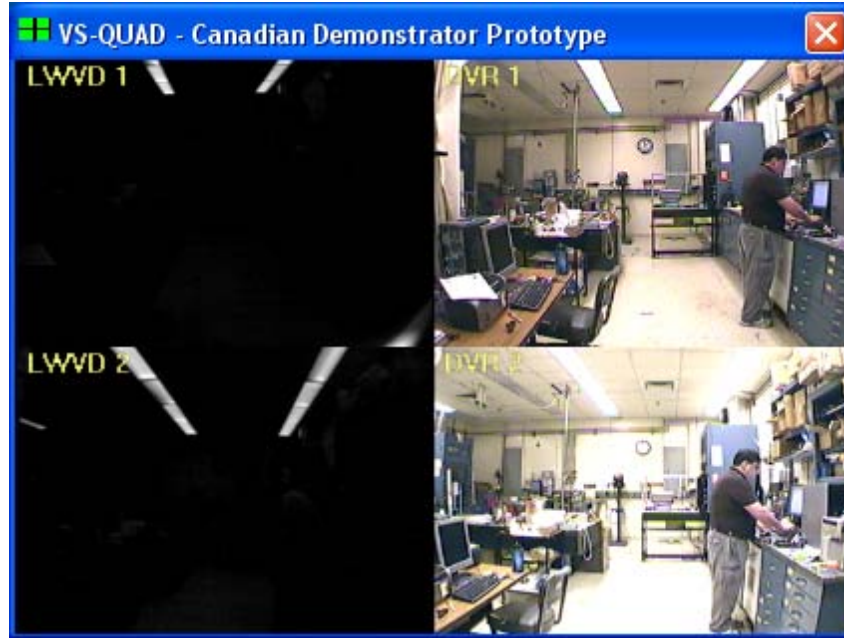

Figure 11-1 – VS_Quad Main Screen

11.1.1. VS_Quad Configuration

All configuration of the VS_Quad application is done by editing the contents of the configuration file (`default.ini`). The configuration file associated with the screen shot in Figure 11-1 is given in File Listing 11-1.

File Listing 11-1 – Annotated Version of the VS_Quad Configuration File (`default.ini`)

```

VS-QUAD - Canadian Demonstrator Prototype    - Title bar text
1                                             - Upper Left Quadrant Active (1=Active, 0=Inactive)
LWVDmemfilemap_1                            - Memory buffer for video feed
LWVD 1                                       - Quadrant label
1                                             - Upper Right Quadrant Active (1=Active, 0=Inactive)
LWVDmemfilemap_2                            - Memory buffer for video feed
DVR 1                                        - Quadrant label
1                                             - Lower Left Quadrant Active (1=Active, 0=Inactive)
LWVDmemfilemap_3                            - Memory buffer for video feed
LWVD 2                                       - Quadrant label
1                                             - Lower Right Quadrant Active (1=Active, 0=Inactive)
LWVDmemfilemap_4                            - Memory buffer for video feed
DVR 2                                        - Quadrant label
1                                             - Pixel number of top edge of application
1                                             - Pixel number of left edge of application
425                                          - Width of application in pixels
320                                          - Height of application in pixels
255 255 128                                  - RGB color for Quadrant labels

```

For the top and left values for the UI screen, the example above in File Listing 11-1 indicate top, left coordinates of (1,1), or one pixel to the right and down from the upper left corner of the screen. As a note, the coordinates (0,0) refer to the center of the screen, not the expected top, left corner of the screen. While not expected to be a routine configuration task, the DirectShow

graph filter needs to be configured one time per computer to establish the link between the LWVD and VS_Quad applications. This is done by running the 'runme.bat' in the VS_Quad binary directory. The path is

```
"C:\Volume Sensor Programs\VS_Quad\bin\runme.bat".
```

11.1.2. VS_Quad Operation

The VS_Quad application can be launched in one of two ways: 1) launching from the command line (or batch file), or 2) by double-clicking on the application icon or an associated shortcut. An example target for a shortcut to launch the VS_Quad application is:

```
"C:\Volume Sensor Programs\VS_Quad\bin\VS_Quad.exe"
```

If the instance is properly configured, the application will launch and run as shown in Figure 11-1. Operation will continue until the application is closed via the 'X' in the upper right corner of the application. At least one instance of the LWVD application must be running prior to launching the VS_Quad application. If the LWVD applications are stopped while the VS_Quad application is running, the images will stop at the last received frame. No other notification is provided.

12. Volume Sensor Command and Control (VS_CnC) Software

Routine operation of the VS_CnC software for the CDP is straightforward and requires no operator intervention. For advanced configuration and usage, additional information is required and presented in this Section.

12.1. VS_CnC Software

The VS_CnC application is designed to be the core of the VS system, providing communications services between all of the VS components, gathering data from the sensor analysis programs, processing the data through the data fusion algorithms, and transmitting situational awareness to the GUI for display. The configuration and operation of the software is briefly described here.

The main application file is named 'CnC_debug.exe'. In addition to this executable file, two dynamic link libraries (DLL) are required for normal program operations. These are 'VSComm_debug.dll', which implements the VS XML communications interface, and 'libxml2.dll', which provides a standard XML programming interface. These files must be located in the same directory as the main application file.

Upon startup, the VS_CnC application main window is displayed, as shown in Figure 12-1. As configured for the CDP, command messages sent from the GUI are counted in the upper text box. Data packets received from the sensor components are counted in the middle text box. A

“heartbeat” counter is displayed in the lower text box and indicates the current data acquisition cycle number and the status of communications.

A series of buttons and checkboxes provide controls for advanced users and for debugging purposes. The Simulation Interface is not intended for use in the CDP. In the lower right, the button labeled ‘Done’ provides a convenient way to close and exit the VS_CnC program.

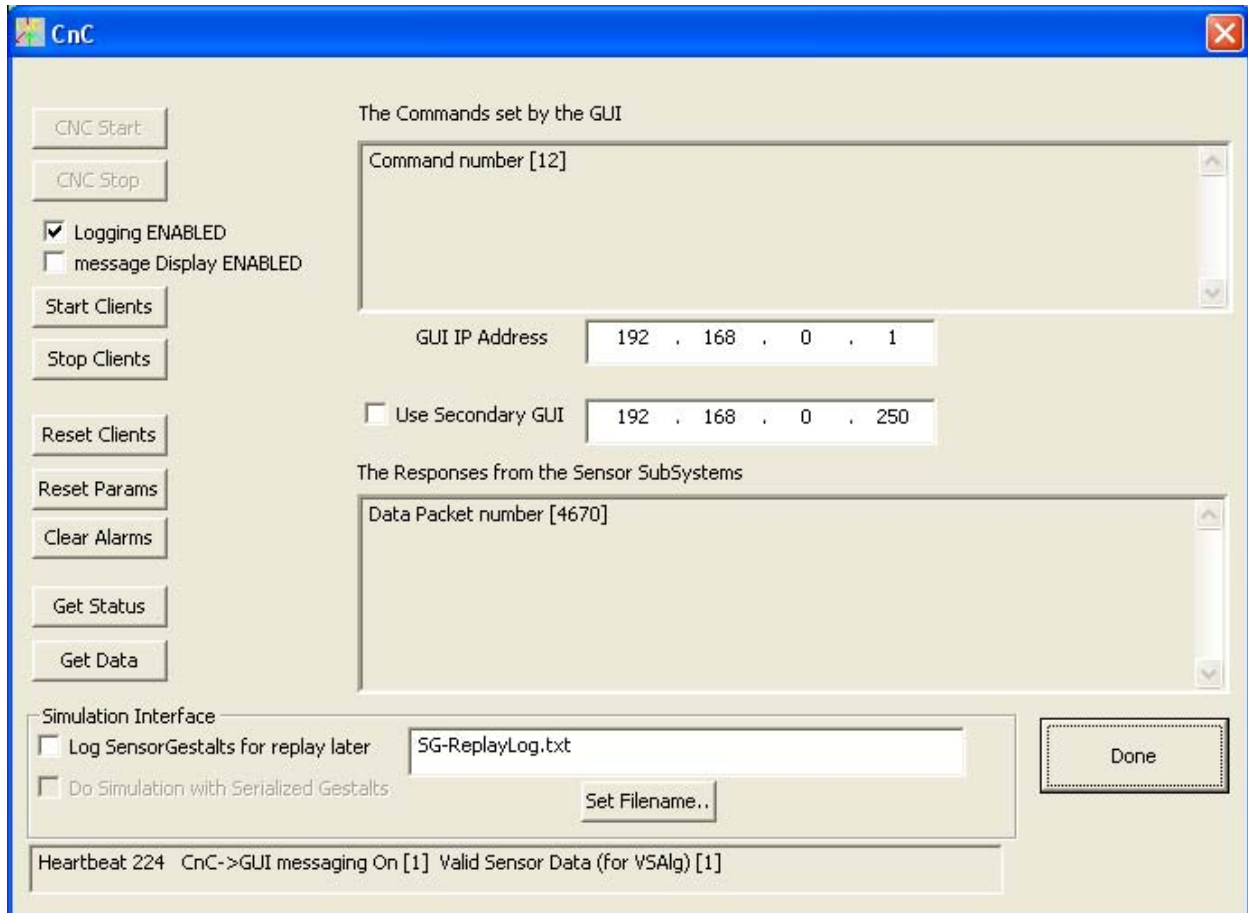

Figure 12-1 – VS_CnC Software Main Screen During Demonstration

12.2. Operation

The VS_CnC application can be launched in one of two ways: 1) launching from the command line (or batch file), or 2) by double-clicking on the application icon or an associated shortcut. An example target for a shortcut to launch the VS_CnC application is:

```
"C:\Volume Sensor Programs\VS_CnC\CnC_debug.exe"
```

The application will launch and run as shown in Figure 12-1. Operation will continue until the application is closed via the ‘Done’ button in the lower right corner of the application, or the ‘X’ in the upper right corner of the application.

Normal operation do not require the operator to use the other buttons or checkboxes on the VS_CnC application. All operator interaction with the CDP system should be performed through the GUI. However, if the VS_GUI application becomes unresponsive (i.e., “freezes”) or the GUI clock stops advancing during CDP system demonstration, then it is recommended that the ‘Stop Clients’ button on the VS_CnC application be pressed to terminate data acquisition from the sensor systems. The VS_GUI and VS_CnC applications may then be closed and restarted for continued use. Further information regarding the VS_GUI application can be found in Section 13.

12.3. Configuration

All configuration of the VS_CnC application is done by editing the contents of the configuration files listed in Table 12-1. These files are located in the same directory as the VS_CnC executable and tell the VS_CnC application which IP addresses and port numbers to use for itself, the GUI, and the VID application. In addition, the type of machine vision software (e.g. vendor) is set. Note that only one VID system, axonX Fike’s *SigniFire*, is supported for the CDP. The NRL VSP can support a second GUI application, however one GUI is available for use in the CDP.

Table 12-1 – VS_CnC Configuration Files

CnC_Config.txt	Sets the IP address of the VS_CnC application and the IP address of the machine vision sensor component.
VSAlgConfig.txt	Sets the machine vision software type for the data fusion algorithms.
GUIClientConfig.txt	Sets the IP address and port numbers for communications with the GUI application.
GuiSecondaryConfig.txt	Sets the IP address and port numbers for communications with a secondary GUI application. (Not used in the CDP.)

12.4. VS_CnC Communications Interface Configuration

Configuration of the XML communications interface for the VS_CnC application is done by editing the contents of the XML system definition files listed in Table 12-2. These files define the IP addresses and port numbers of all VS components for the XML communications interface. They also define the structure of the data packets to be received by the VS_CnC application during normal operations. The first file listed in Table 12-2, ‘server.xml’, is located in the same directory as the VS_CnC application file. The other files, all prefaced with ‘sysdef_’, are located in the ‘config/’ subdirectory and must match exactly the system definition files located with the sensor applications.

Table 12-2 – VS_CnC XML Communications Files

server.xml	XML definition file for communications with the VS_CnC application.
config/sysdef_SBVS_SS1_001.xml	XML definition file for communications with the SBVS application processing data from SS #1.
config/sysdef_SBVS_SS2_001.xml	XML definition file for communications with the SBVS application processing data from SS #2.
config/sysdef_LWVD_SS1_001.xml	XML definition file for communications with the LWVD application processing NIR video from SS #1.
config/sysdef_LWVD_SS2_001.xml	XML definition file for communications with the LWVD application processing NIR video from SS #2.
config/sysdef_VSDVR_SS1_VIS_CPM.xml	XML definition file for communications with the DVR application recording VID video from SS #1.
config/sysdef_VSDVR_SS2_VIS_CPM.xml	XML definition file for communications with the DVR application recording VID video from SS #2.
config/sysdef_ACST_SS1-2.xml	XML definition file for communications with the ACST application processing audio data from SS #1 and #2.
config/sysdef_SF_2Cam.xml	XML definition file for communications with the <i>SigniFire</i> application processing video from IP cameras #1 and #2.

12.5. Data Logging

The VS_CnC application uses several log files to record all data received from the sensor applications and all data fusion processing performed with that data. The VS_CnC data files are stored in the same directory as the VS_CnC executable,

```
"C:\Volume Sensor Programs\VS_CnC\"
```

These log files are listed in Table 12-3. The first log file listed in the table is created whenever the VS_CnC application is started. A new version of the file with a unique filename is generated whenever the log file is removed from the directory while the VS_CnC application is running. The unique filename is generated based on the current computer date and time. The other log files listed in the table are continuously updated if they already exist, or are created anew if they don't, whenever a 'Start' command is received from the VS_GUI application. Their filenames are static and do not change.

Table 12-3 – VS_CnC Data Logging Files

CNC_LogFile_(date)_(time).txt	Stores all data packets and command messages received or sent by the CnC application.
DFAM_Log.txt	Records pertinent messages pertaining to the operation of the data fusion algorithms module.
dataSS1_Log.txt	Records data received from SS #1 at one second time intervals.
dataSS2_Log.txt	Records data received from SS #2 at one second time intervals.
dataDF1_Log.txt	Records output of individual data fusion algorithms at one second time intervals.

13. Volume Sensor Graphical User Interface (VS_GUI) Software

Routine operation of the VS_GUI software for the CDP is straightforward. The purpose of this section is to provide the operator with more detail about the VS_GUI application. For advanced configuration and usage, additional information is required and presented in this Section.

13.1. VS_GUI Software

The VS_GUI application is designed to be the human interface to the VS system, providing the operator with communications services to the VS components and displaying situational awareness gathered from the sensor analysis programs and the data fusion algorithms. The configuration and operation of the software are briefly described here.

The main application file is 'VSMonV1.exe'. In addition to this executable file, two other files are required for normal program operations. These are 'Falcon.dll', which provided a video interface that is not available in the CDP, and 'VSMonV1.pdb', which was used for runtime debugging. The layout and configuration of the VS_GUI application is contained in file 'Default.txt', which sets the IP address and port numbers for communications with the VS_CnC software and also defines the locations, names, and data content of the sub windows displayed in the main VS_GUI application window. The definition file is intricate and complex and should not be altered by the CDP operator. All of these files must be located in the same directory as the main application file. These files are located in the location:

```
"C:\Volume Sensor Programs\VS_GUI\"
```

13.2. Operation

The VS_GUI application can be launched in one of two ways: 1) launching from the command line (or batch file), or 2) by double-clicking on the application icon or an associated shortcut. An example target for a shortcut to launch the VS_GUI application is:

```
"C:\Volume Sensor Programs\VS_GUI\VSMonV1.exe"
```

The application will launch and the main display will appear similar the one shown in Figure 13-1. Operation will continue until the application is closed by the operator via the 'File' menu 'Exit' command, or the 'X' in the upper right corner of the application.

The GUI communicates with the VS components through messages sent to the VS_CnC application. In order to establish communications, the operator needs to initialize the VS system. This is accomplished by pressing the 'Initialize' button in the Command Toolbar, as shown in Figure 13-2(a). After which, the Sensor Subsystem window in the lower right of the VS_GUI main window should appear as in Figure 13-3(top). The sensor systems listed in this window are either green or gray, indicating OK or HALT status. The VSALG system represents the data

fusion algorithms and is in the OFF state at initialization. If one of the sensor systems shows an orange FAULT state or a gray OFF state, then additional intervention by the operator is required. Ensure all hardware, connections and software systems are functioning properly before attempting initialization again.

Once the initialization procedure is complete, the system is ready for demonstration. Press the 'Start' button shown in Figure 13-2 (a) to activate the system and commence data acquisition. Normal operations do not require the operator to use the other buttons or command menus on the VS_GUI application. The Sensor Subsystem window should now appear as shown in Figure 13-3 (bottom) with all systems in green with OK status. In addition, the two boxes in the upper left of the main GUI window change from gray to green. The upper box indicates whether the system is started or stopped, and the time at which the system was started or stopped. The lower box indicates the current system status: green OK, red ALARM (time), or gray STOPPED. Two operational states are shown in Figure 13-2 (a) and (b) as examples.

If the GUI becomes unresponsive (i.e., "freezes") or the GUI time clock display ceases to advance during a system demonstration, then it is recommended that the VS_GUI application be closed and the 'Stop Clients' button on the VS_CnC application be pressed to terminate data acquisition from the sensor systems. The VS_GUI and VS_CnC applications may then be closed and restarted for continued use.

While running, the GUI provides a number of indicators for situational awareness. An example is the active FLAME alarm shown in Figure 13-4. In general, threat levels are color coded as green (OK), yellow (PRE ALARM), and red (ALARM). Orange is used to indicate a FAULT state, and gray an OFF or HALT.

To cease data acquisition and stop the system, press the 'Stop' button shown in Figure 13-2 (b).

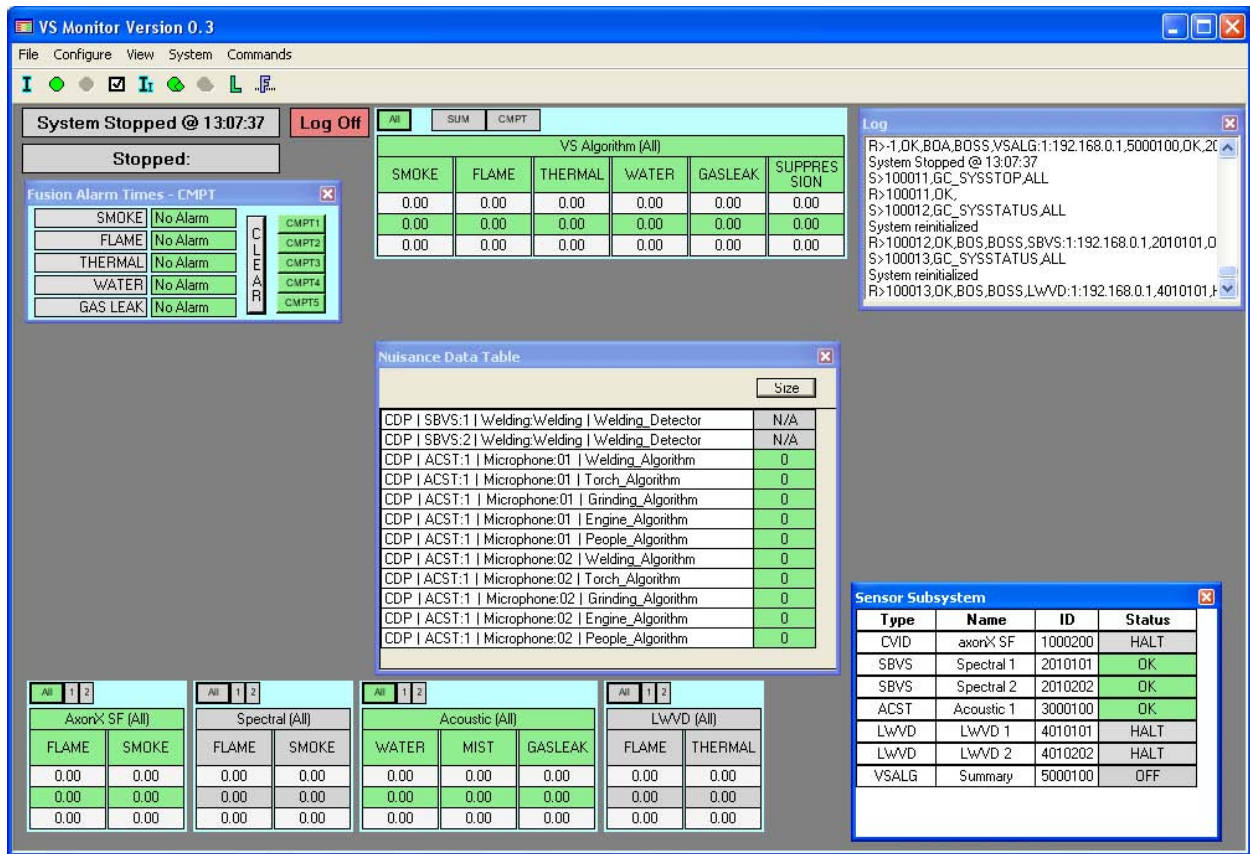

Figure 13-1 – VS_GUI Software Main Screen

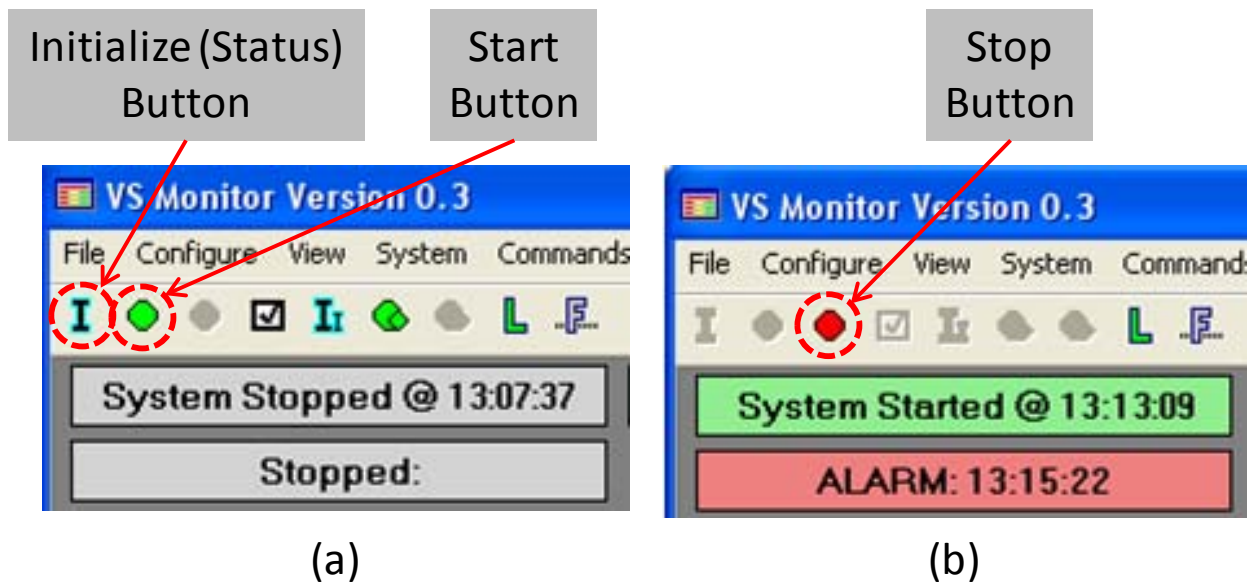

Figure 13-2 – VS_GUI Application (a) Initialization and Start Buttons (b) Stop Button

Type	Name	ID	Status
CVID	axorX SF	1000200	HALT
SBVS	Spectral 1	2010101	OK
SBVS	Spectral 2	2010202	OK
ACST	Acoustic 1	3000100	OK
LWVD	LWVD 1	4010101	HALT
LWVD	LWVD 2	4010202	HALT
VSALG	Summary	5000100	OFF

Type	Name	ID	Status
CVID	axorX SF	1000200	OK
SBVS	Spectral 1	2010101	OK
SBVS	Spectral 2	2010202	OK
ACST	Acoustic 1	3000100	OK
LWVD	LWVD 1	4010101	OK
LWVD	LWVD 2	4010202	OK
VSALG	Summary	5000100	OK

Figure 13-3 – VS_GUI Sensor Subsystem Window, (top) After Initialization, (bottom) Normal Operations

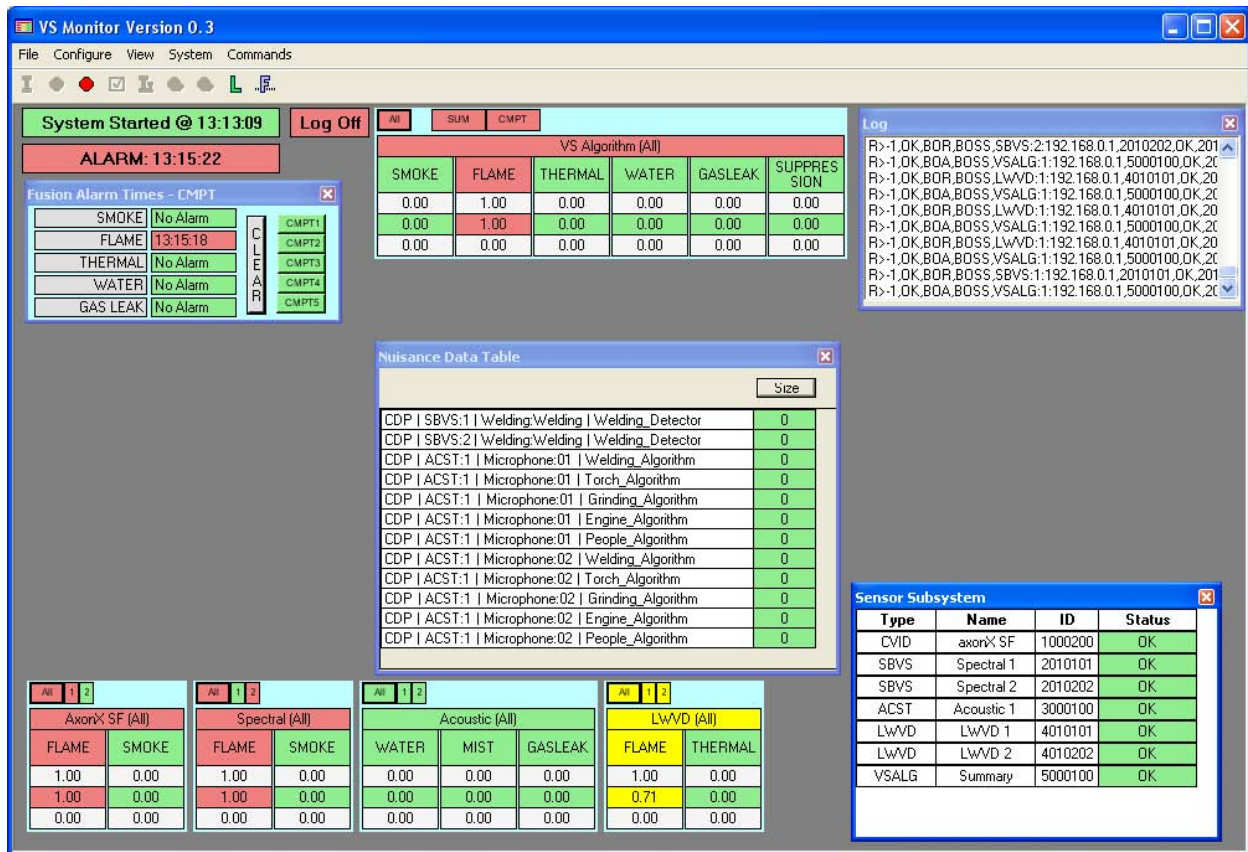

Figure 13-4 – VS_GUI Software Main Screen With Active FLAME Alarm

13.3. Situational Awareness

The GUI provides a number of indicators for situational awareness. These are found on the various sub windows located in the main window of the VS_GUI application. The default size and layout of the sub windows is shown in Figure 13-1. Most of the sub windows can be resized and re-positioned at the convenience of the system operator. For the remainder of this section, the 'sub' nomenclature will be dropped when a sub window is referred to.

13.3.1. The LOG Window

The LOG window is located in the upper right of the VS_GUI application. The purpose of the LOG window is to display all messages sent from and received by the VS_GUI application.

Two examples of VS_CnC / VS_GUI message traffic, as shown in the LOG window, are shown in Figure 13-5. Typical entries for system commands are shown in Figure 13-5 (top). These include pressing the 'Stop' button, which sends a STOP command to the VS_CnC and generates an 's>10011,GC_SYSSTOP,All' entry in the LOG window. The 's>' indicates the message was sent from the VS_GUI application, the '10011' is the message identification number, and the 'GC_SYSSTOP,All' test string is the System Stop message for distribution to all sensor

components. The VS_CnC confirms receipt of the message in the subsequent LOG entry, 'R>10011,OK'. Entries for pressing the 'Initialization' button are also shown: 'R>10011,GC_SYSSTATUS,All'. In this case, the sensor systems respond with their current system status.

After a 'Start' command is issued by the GUI operator, data packets are received in a continuous stream from the VS_CnC, as shown in Figure 13-5 (bottom). Data packets from sensor systems, 'R>-1,OK,BOR', alternate with packets from the data fusion algorithms, 'R>-1,OK,BOA'.

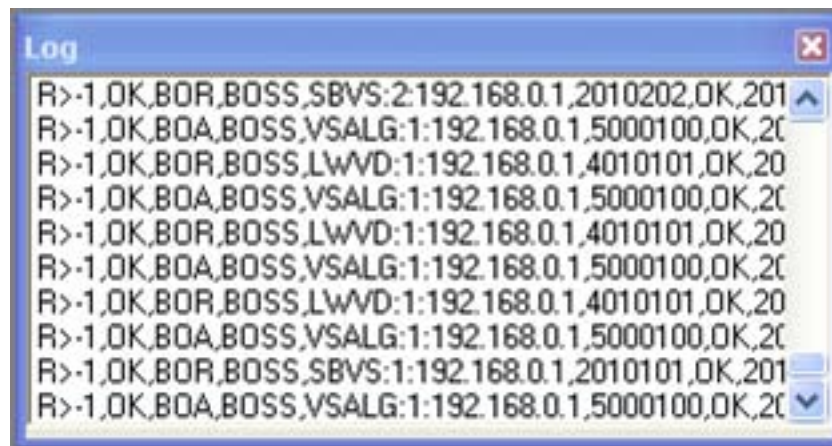
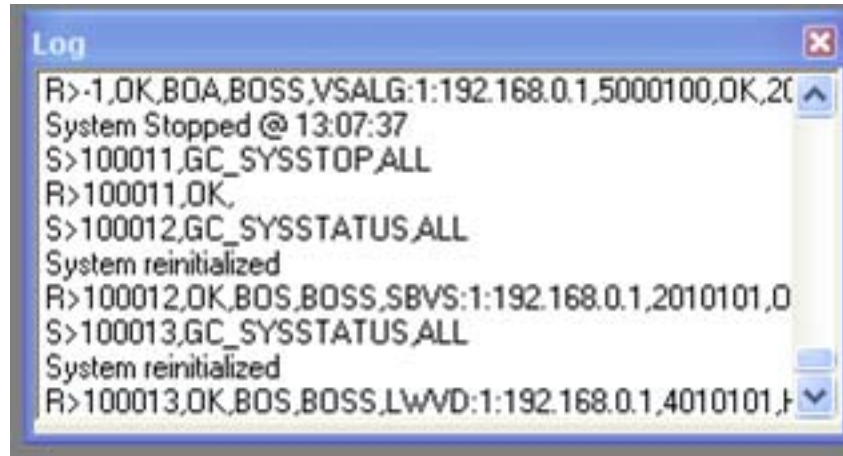

Figure 13-5 – The VS_GUI LOG Window, (top) Command Messages, (bottom) Data and Algorithm Packets

13.3.2. The SENSOR SUBSYSTEM Window

The SENSOR SUBSYSTEM window is located in the lower right of the VS_GUI application's main screen. The purpose of the SENSOR SUBSYSTEM window is to display the status of the sensor subsystems and the data fusion algorithms module. Two examples the sensor subsystem

status, as reported in the SENSOR SUBSYSTEM window, are shown in Figure 13-3 and discussed in the Section 13.2. The Type/Name entries indicate the status of the *SigniFire* machine vision system (CVID/axonX SF), the spectral sensors in SS #1 (SBVS/Spectral 1) and SS #2 (SBVS/Spectral 2), the NIR video stream in SS #1 (LWVD/LWVD 1) and SS #2 (LWVD/LWVD 2), the acoustics system (ACST/Acoustic 1), and the data fusion algorithms module (VSALG/Summary). The possible status states are OFF or HALT (gray), OK (green) and FAULT (orange).

13.3.3. The SENSOR ALARM Windows

The SENSOR ALARM windows are located in the lower left and middle of the VS_GUI application's main screen. The purpose of the SENSOR ALARM windows is to display the current threat levels and the recent minimum and maximum threat levels for several of the sensor alarm algorithms. These threat levels do not latch, meaning no values or conditions presented in these windows are persistent.

Two threat level examples for the SENSOR ALARM windows are shown in Figure 13-6. Typical entries for the initialization state are shown in Figure 13-6 (top). A FLAME event detected on the machine vision (AxonX SF), SBVS (Spectral) and LWVD (LWVD) systems is shown in Figure 13-6 (bottom). The current threat level, scaled from 0.00 to 1.00, is indicated by the middle row of numbers and is color coded green (OK), yellow (PRE ALARM), and red (ALARM). The maximum threat level in the last 30 seconds is indicated by the top row, the minimum by the bottom row. The buttons 'All', '1', and '2', at the top of the SENSOR ALARM windows allow the operator to alter what information is displayed. By selecting '1', only information from SS #1 is displayed for that sensor subsystem. Select '2' for SS #2, and select 'All' to display the greater threat level of either SS #1 or SS #2. The default state is 'All'.

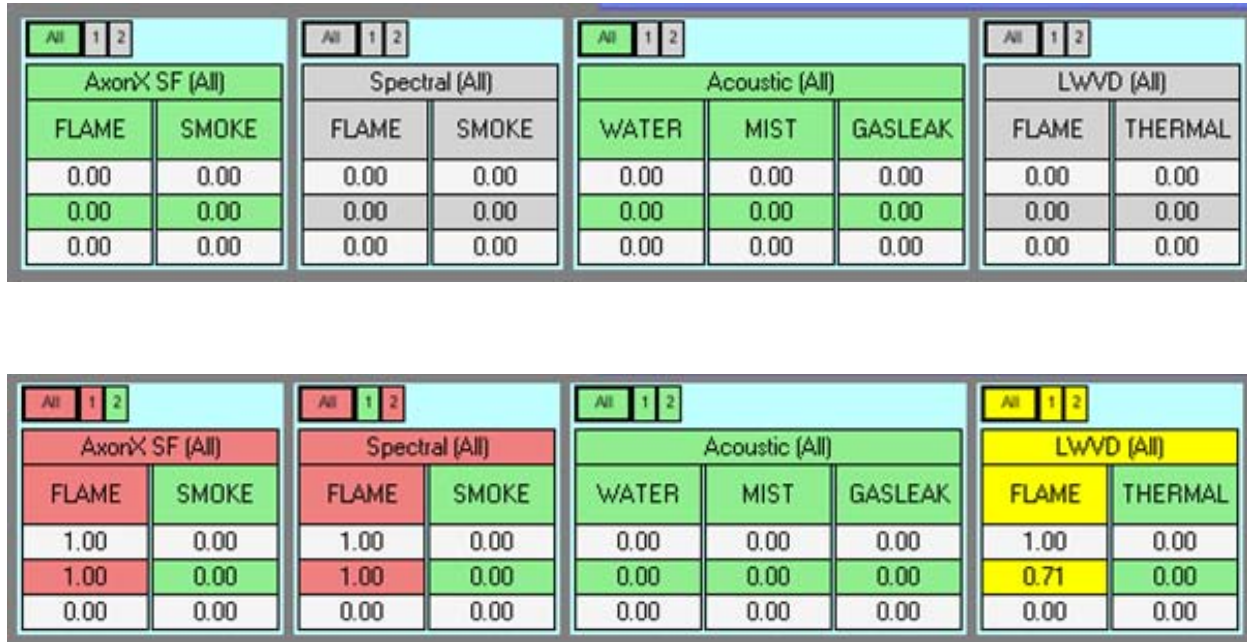

Figure 13-6 – The VS_GUI SENSOR ALARM Windows, (top) After Initialization, (bottom) With Active FLAME Alarms

13.3.4. The VS ALGORITHMS Window

The VS ALGORITHMS window is located in the upper middle of the VS_GUI application. The purpose of the VS ALGORITHMS window is to display the current threat levels and the recent minimum and maximum threat levels for data fusion algorithms. These threat levels do latch and can only be reset by issuing a ‘Stop’ command followed by an ‘Initialization’ command.

Two data fusion algorithm threat level examples for the VS ALGORITHMS window are shown in Figure 13-7. Typical entries for the initialization state are shown in Figure 13-7 (top). A FLAME event detected by the flaming fire data fusion algorithm is shown in Figure 13-7 (bottom). The threat levels and status indicators are identical to those used in the SENSOR ALARM windows.

The figure consists of two screenshots of the VS_GUI VS ALGORITHMS window. Both screenshots show a window with a light blue header containing three buttons: 'All' (highlighted in green in the top screenshot, red in the bottom), 'SUM', and 'CMPT'. Below the header is a table titled 'VS Algorithm (All)' with six columns: SMOKE, FLAME, THERMAL, WATER, GASLEAK, and SUPPRES SION. The table has three rows of data.

Top Screenshot (After Initialization):

SMOKE	FLAME	THERMAL	WATER	GASLEAK	SUPPRES SION
0.00	0.00	0.00	0.00	0.00	0.00
0.00	0.00	0.00	0.00	0.00	0.00
0.00	0.00	0.00	0.00	0.00	0.00

Bottom Screenshot (With Active Data Fusion FLAME Alarm):

SMOKE	FLAME	THERMAL	WATER	GASLEAK	SUPPRES SION
0.00	1.00	0.00	0.00	0.00	0.00
0.00	1.00	0.00	0.00	0.00	0.00
0.00	0.00	0.00	0.00	0.00	0.00

Figure 13-7 – The VS_GUI VS ALGORITHMS Window, (top) After Initialization, (bottom) With Active Data Fusion FLAME Alarm

13.3.5. The FUSION ALARM TIMES Window

The FUSION ALARM TIMES window is located in the upper left of the VS_GUI application's main screen. The purpose of the FUSION ALARM TIMES window is to display the alarm status and alarm times generated by the data fusion algorithms module until cleared by the operator. These alarms do latch and can only be reset by the 'Clear' button next to the alarm times. Note that pressing the 'Clear' button only clears the display and does not reset the alarm latches in the data fusion algorithms module. A 'Stop' command followed by a 'Start' command is required to reset the fusion algorithms in the VS_CnC software.

The FUSION ALARM TIMES window corresponding to two example conditions are shown in Figure 13-8. Typical entries for the initialization state are shown in Figure 13-8 (top). A FLAME event detected by the flaming fire data fusion algorithm is shown in Figure 13-8 (bottom). The compartment buttons are not enabled for the CDP.

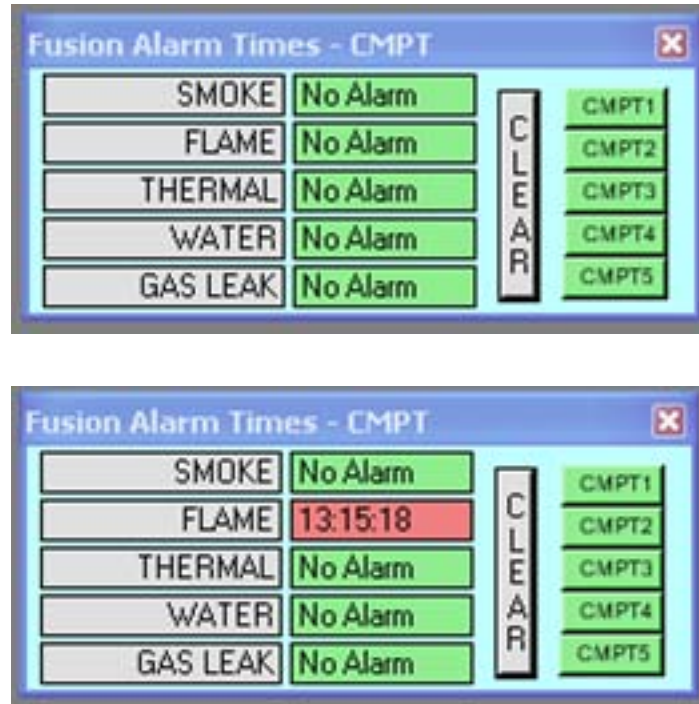

Figure 13-8 – The VS_GUI FUSION ALARM TIMES Window, (top) After Initialization, (bottom) With Active Data Fusion FLAME Alarm

13.3.6. The NUISANCE DATA TABLE Window

The NUISANCE DATA TABLE window is located in the middle of the VS_GUI application's main screen. The purpose of the NUISANCE DATA TABLE window is to display the current status of several nuisance scenarios as detected by the sensor systems. These alerts do not latch.

An example of the NUISANCE DATA TABLE window is shown in Figure 13-9. The nuisance scenarios shown are welding, grinding, torch cutting, engine running, and people working in the space. Alert levels follow the same scale (0.00 – 1.00) and color coding as with alarm levels. Note that when the welding, grinding, and torch cutting (i.e., bright nuisance) scenarios reach red (1.0), FLAME and SMOKE alarms at the fusion level are blocked. Blocking of these alarms continues until 60 seconds after bright nuisance alert is no longer observed.

				Size
CDP SBVS:1 Welding:Welding Welding_Detector				N/A
CDP SBVS:2 Welding:Welding Welding_Detector				N/A
CDP ACST:1 Microphone:01 Welding_Algorithm				0
CDP ACST:1 Microphone:01 Torch_Algorithm				0
CDP ACST:1 Microphone:01 Grinding_Algorithm				0
CDP ACST:1 Microphone:01 Engine_Algorithm				0
CDP ACST:1 Microphone:01 People_Algorithm				0
CDP ACST:1 Microphone:02 Welding_Algorithm				0
CDP ACST:1 Microphone:02 Torch_Algorithm				0
CDP ACST:1 Microphone:02 Grinding_Algorithm				0
CDP ACST:1 Microphone:02 Engine_Algorithm				0
CDP ACST:1 Microphone:02 People_Algorithm				0

Figure 13-9 – The VS_GUI NUISANCE DATA TABLE Window after Initialization

14. System Component Specifications

This section briefly enumerates the major components of the CDP, their configurations, the vendors, and part numbers.

The Fusion Machine computer:

- Hewlett-Packard Z400 Workstation
- Intel Xeon W3565 Quad-core CPU @ 3.2 GHz
- 4 GB of RAM
- Windows XP Professional x86 Service Pack 3
- NVIDIA Quadro NVS 295 display adapter
- IDS FALCONquattro express 4-channel frame grabber, PCIe version
- Lynx LynxTWO-A audio card
- Lynx audio cable, P/N: CBL-L2AUDIO
- 500 GB main hard drive
- 1 TB data hard drive

The *SigniFire* computer:

- Custom unit provided by vendor, axonX Fike
- Intel Core™2 Duo E8400 CPU @ 3.0 GHz

- 1 GB of RAM
- Windows XP Professional x86 Service Pack 3
- Integrated Intel graphics
- 2 TB main hard drive

Phantom Power Supply

- Stewart Audio, 48V Phantom Supply Module, P/N: PM-4

Network Ethernet Switch

- Linksys 8-Port 10/100 + 2-Port Gigabit Switch, P/N: SRW208P

Fieldpoint Unit

- Rugged Intelligent Ethernet Controller Interface, NI cFP-2000
- 8-Channel Analog Voltage and Current Input Module for Compact Fieldpoint, NI cFP-AI-110
- 8 Ch, 5 to 24 V Sourcing Counter Compact Fieldpoint Module, NI cFP-CTR-502
- Integrated Connector Block for Wiring to Compact Fieldpoint I/O, NI cFP-CB-1, 2 each
- Phoenix Contact 24 VDC Power Supply, P/N: Quint-PS-100-240AC/24DC/5
- Cosel 5 VDC DC/DC Converter, P/N: ZUS102405

CDP sensor head accessories

- Power supply, SL Power (Ault / Condor) P/N: PW173KB2403F01, 3 each
- Optical sensor data cable, L-Com P/N: CSM9MF-50, 3 each
- Video cable, L-Com P/N: CC59A-50, 6 each

15. References

1. "Volume Sensor for Damage Assessment and Situational Awareness," Susan L. Rose-Pehrsson, Christian P. Minor, Daniel A. Steinhurst, Jeffrey C. Owrutsky, James A Lynch, Daniel T. Gottuk, Stephen C. Wales, John P. Farley, Frederick W. Williams, *Fire Safety Journal*, **2006**, *41*, 301 – 310.
2. "Volume Sensor Development Test Series 5 – Multi-Compartment System," J.A. Lynch, D.T. Gottuk, J.C. Owrutsky, D.A. Steinhurst, C.P. Minor, S.C. Wales, J.P. Farley, S.L. Rose-Pehrsson, and F.W. Williams, NRL Memorandum Report NRL/MR/6180—05-8931, NRL, Washington, DC, December 30, 2005.
3. "A Full-Scale Prototype Multisensor System for Damage Control and Situational Awareness," Christian P. Minor, Daniel A. Steinhurst, Kevin J. Johnson, Susan L. Rose-Pehrsson, Jeffrey C. Owrutsky, Stephen C. Wales, and Daniel T. Gottuk, *Fire Technology*, **2010**, *46*, 437-469.

4. "Long Wavelength Video Detection of Fire in Ship Compartments," Jeffrey C. Owrutsky, Daniel A. Steinhurst, Christian P. Minor, Susan L. Rose-Pehrsson, Frederick W. Williams, Daniel T. Gottuk, *Fire Safety Journal*, **2006**, *41*, 315 – 320.
5. "NRL Volume Sensor: Long Wavelength Video Detection Component Prototype: Pre-Test Series 3 Progress Report," D.A. Steinhurst, C.P. Minor, J.C. Owrutsky, S.L. Rose-Pehrsson, and F.W. Williams, Naval Research Laboratory Letter Report Number 6110/110, August 24, 2004.
6. "Evaluation of the LWVD Luminosity for Use in the Spectral-Based Volume Sensor Algorithms," D.A. Steinhurst and J.C. Owrutsky, NRL Memorandum Report NRL/MR/6110—10-9252, Naval Research Laboratory, Washington, DC, April 27, 2010.
7. "Spectral-Based Volume Sensor Prototype, Post-VS4 Test Series Algorithm Development," D.A. Steinhurst and J.C. Owrutsky, NRL Memorandum Report NRL/MR/6110—09-9190, Naval Research Laboratory, Washington, DC, April 30, 2009.
8. "Acoustic Event Signatures for Damage Control: Water Events and Shipboard Ambient Noise," S.C. Wales, M.T. McCord, J.A. Lynch, S.L. Rose-Pehrsson, F.W. Williams, NRL Memorandum Report NRL/MR/7120—04-8845, Naval Research Laboratory, Washington, DC, December 10, 2004.
9. "Canadian Demonstrator Prototype Evaluation And Demonstration Plan," J.B. Hoover, A.F. Durkin, H.V. Pham, S.L. Rose-Pehrsson, S.C. Wales, C.P. Minor and D.A. Steinhurst, NRL Letter Report 6180/0233, Naval Research Laboratory, Washington, DC, October 29, 2010.
10. "Canadian Demonstrator Prototype, Spectral-Based Volume Sensor, User's Guide," Version 1, 09/05/2010.
11. "Canadian Demonstrator Prototype, Long-Wavelength Video Detection System, User's Guide," Version 1, 09/05/2010.
12. The Xvid codec is freely downloadable from <http://www.xvid.org/>.
13. "Canadian Demonstrator Prototype, Acoustic Volume Sensor Subsystem, User's Guide," Version 1, 11/05/2010.
14. *LynxTWO Installation and User's Guide*, Lynx Studio Technology, Inc., 1048 Irvine Ave # 468, Newport Beach, CA 92660, (January 21, 2004).
15. *LynxTwo Quick Start Guide*, Lynx Studio Technology, Inc., 1048 Irvine Ave # 468, Newport Beach, CA 92660, (July 10, 2006).

16. “Canadian Demonstrator Prototype, *SigniFire*, User’s Guide,” Version 1, 09/05/2010.
17. “*SignFire IP*TM Smoke and Fire Detection Camera, Operations and Installation Manual,” Fike, P/N 06-523, Rev. 2, 6/2010.
18. “*SpyderGuard IP*TM, Operations Manual,” Fike, P/N 06-522, Rev. 1, 7/2010.
19. Private communication, George Privalov, axonX Fike, 05/2010.
20. “*FSM-IP*TM, Network Video Recorder, Operations Manual,” Fike, P/N 06-521, Rev. 1, 7/2010.
21. “Canadian Demonstrator Prototype, VS_Quad UI, User’s Guide,” Version 1, 09/05/2010.

