

ERDC/CHL CR-11-1

Coastal and Hydraulics Laboratory



**US Army Corps
of Engineers®**
Engineer Research and
Development Center

Urban Flood Damage Reduction and Channel Restoration Development and Demonstration Program for Arid and Semi-Arid Regions (UFDP); Southwest Urban Flood Damage Program (SWDP)

Investigating Groundwater/Surface Water Interaction at Diversion Dam Site: Report Documentary 2007-2008

Julie Coonrod, Cliff Crawford, John Stormont,
Christian LeJeune, and Isaiah Pedro

May 2011

Urban Flood Damage Reduction and Channel
Restoration Development and Demonstration
Program for Arid and Semi-Arid Regions (UFDP);
Southwest Urban Flood Damage Program
(SWDP)

ERDC/CHL TR-11-1
May 2011

Investigating Groundwater/Surface Water Interaction at the Diversion Dam Site: Report Documentary 2007-2008

Julie Coonrod, Cliff Crawford, John Stormont, Christian LeJeune, and Isaiah Pedro

*University of New Mexico
MSC01 1070 Civil Engineering
Albuquerque, NM 87120*

Final report

Approved for public release; distribution is unlimited.

Prepared for U.S. Army Corps of Engineers
Washington, DC 20314-1000

Monitored by Coastal and Hydraulics Laboratory
U.S. Army Engineer Research and Development Center
3909 Halls Ferry Road, Vicksburg, MS 39180-6199

Abstract: This report concerns hydrological monitoring of groundwater wells installed with pressure transducers at four Bosque Ecosystem Monitoring Program (BEMP) sites, which bracket the Albuquerque Drinking Water Diversion Dam (DWD). The data obtained from these pressure transducers are coupled with river discharge and stage data from the U.S. Geological Survey's (USGS) river gauge 08329918 (at Alameda Bridge) located approximately 450 m north of the DWD, to provide a database for the purpose of estimating the interaction between groundwater and surface water, as well as the potential effects of the DWD in this urban stretch of the Rio Grande.

Also included in this report is a description of the monitoring sites, the techniques used to install shallow groundwater wells and manage pressure transducers, and a presentation and analysis of groundwater data results from before, during, and after DWD construction, with a focus on the first year of baseline data covering the period of October 2006 through September 2007. This data are used to perform a variety of analyses, which assist in understanding how groundwater levels are influenced by river discharge, rain events, DWD trial operations, and soil properties.

Key findings of this study indicate that soils within the study reach are conductive, with groundwater responding quickly to river stage changes. Groundwater levels are mainly a function of the boundary conditions (river and riverside drains), and become deeper towards the levees. Lateral hydraulic gradients are less than 1 percent between wells, with no major changes during the study period. Effects of DWD construction produced about a 9-month disruption in water tables mainly at the Diversion (ED10) site. Water tables then returned to preconstruction values.

DISCLAIMER: The contents of this report are not to be used for advertising, publication, or promotional purposes. Citation of trade names does not constitute an official endorsement or approval of the use of such commercial products. All product names and trademarks cited are the property of their respective owners. The findings of this report are not to be construed as an official Department of the Army position unless so designated by other authorized documents.

DESTROY THIS REPORT WHEN NO LONGER NEEDED. DO NOT RETURN IT TO THE ORIGINATOR.

Contents

Figures and Tables	v
Preface	vii
1 Introduction	1
2 Measure and Monitor Groundwater Response to Dam Operation and Changes in River Flows	2
Purpose.....	2
Groundwater monitoring.....	2
Site characterization	3
Well naming system and well installation dates.....	5
Methods.....	5
<i>Groundwater wells</i>	5
<i>Pressure transducers</i>	6
<i>Pressure transducer installation procedure and maintenance</i>	8
<i>Pressure transducer programming</i>	10
<i>Logger maintenance</i>	13
Results	14
Pre-UFDP well-monitoring and results.....	16
3 Develop Detailed Map of Soils and Their Properties in Bosque Adjacent to Dam	22
Well/core identification.....	22
Field investigation	23
<i>Coring</i>	23
<i>Visual-manual classification</i>	24
<i>In-situ density</i>	24
Laboratory classification.....	25
Summary of results	26
<i>Visual-Manual Method</i>	26
<i>Laboratory methods</i>	27
4 Evaluate Ecological Impact of River Levels, Soil Types, and Dam Operations on Riparian Forest	32
Riparian vegetation changes adjacent to Drinking Water Diversion Dam	32
<i>Introduction</i>	32
<i>Site descriptions</i>	32
<i>Vegetation transect measurements</i>	33
<i>Discussion</i>	34
5 Conclusions	35
References	36

Appendix A: Visual Manual Core Profile.....	37
Appendix B: Laboratory Core Profile Data Sheet	42
Appendix C: Laboratory Core Profile.....	47
Appendix D: Minnow (WD12) Core Data Sheets	52
Appendix E: Bobcat (WU22) Core Data Sheets	103
Appendix F: Badger (EU21) Core Data Sheets.....	184
Appendix G: Diversion (ED10) Core Data Sheets.....	281
Appendix H: Groundwater Monitoring	322
Report Documentation Page	

Figures and Tables

Figures

Figure 1. Site map	3
Figure 2. Typical BEMP site map.....	4
Figure 3. Typical well casing above ground.....	7
Figure 4. Solinst Gold Model 3001 pressure transducer.	8
Figure 5. Christian LeJeune of UNM with well beeper.....	9
Figure 6. Direct read cable.....	10
Figure 7. Diagram showing measurements needed to calculate DWT.....	11
Figure 8. Example interface for Solinst Levellogger Software Version 3.06.....	12
Figure 9. Sample database used to calculate DWT and WTE.	12
Figure 10. Data collection and verification sheet.....	14
Figure 11. Four bank wells with water table elevation fluctuation.....	17
Figure 12. Four bank wells with water table elevation and Alameda and Paseo gauges.....	18
Figure 13. Four bank wells and water table elevation over a 72-hr time period during DWD trial operations.....	19
Figure 14. First row of sheet pilings being pounded into riverbed, 9 February 2005.	20
Figure 15. Groundwater depths just above DWD (open symbols: Bobcat (WU22) and Badger (EU21) and just below dam (closed symbols: Minnow (WD12) and Diversion (ED10). Data are from center wells only	20
Figure 16. Monthly groundwater depth averages of all five wells at each site below DWD. Minnow (WD12) on west side and Diversion (ED10) on east side of river	21
Figure 17. Photograph of study area identifying monitoring site locations where coring took place.....	23
Figure 18. Plan view showing location of core hole relative to existing groundwater monitoring wells.	24
Figure 19. Flow chart of laboratory testing including ASTM standard testing methods.....	26
Figure 20. Visual manual classification profiles for four core holes.	27
Figure 21. Grain size distribution and classification of soils from four core hole profiles in Figure 20	28
Figure 22. Soil classification of soils from four core holes from laboratory analysis.....	31
Figure H-1. Intake screen should capture range in WT elevations if possible.....	323
Figure H-2. Work the seds with the auger to advance the hole.....	323
Figure H-3. Determine intake length. Ex. If DWT = 200 cm, cut 275 cm of screen length.....	323
Figure H-4. Measure effective screen length.	323
Figure H-5. Mark length intervals and the endpoint on the casing before driving the well into the ground.	323
Figure H-7. The annular space should include the sand filter pack and a bentonite seal sandwiched by native seds.....	323

Figure H-6. Tamp the filter pack 323
Figure H-8. Cut two notches at top of casing to locate beeper tape. 323
Figure H-9. Well specs. 323

Tables

Table 1. Monitoring sites and groundwater well installation. 5

Preface

The research presented in this report was developed by the University of New Mexico (UNM) under the direction of the U.S. Army Engineer Research and Development Center (ERDC), Coastal and Hydraulics Laboratory (CHL), Technical Programs Office. Funding was provided by the Urban Flood Damage Reduction and Channel Restoration Development and Demonstration Program for Arid and Semi-Arid Regions (UFDP) and Southwest Urban Flood Damage Program (SWDP) of the USACE General Investigation Research and Development Program. Authorization of the U.S. Army Corps of Engineers to conduct research and development is codified in 10 U.S.C. 2358.

Work was performed under the general supervision of Dr. Lisa C. Hubbard, UFDP and SWDP Program Manager, Dr. Jack E. Davis, Technical Director for Flood and Coastal Storm Damage Reduction, William R. Curtis, Program Manager of the Flood and Coastal Storm Damage Reduction Research and Development Program, Dr. William D. Martin, Director, CHL, and Jose Sanchez, Deputy Director, CHL. This report was prepared by Dr. Julie Coonrod, Dr. Cliff Crawford, Dr. John Stormont, Christian LeJeune, and Isaiah Pedro, all of the University of New Mexico. Technical reviews were conducted by Ondrea Hummel and Darryl Eidson, both of the U.S. Army Engineer District, Albuquerque, Meg M. Jonas of ERDC-CHL, and Dr. Hubbard.

At the time of publication, COL Kevin J. Wilson was Commander and Executive Director of ERDC and Dr. Jeffery P. Holland was Director of ERDC.

1 Introduction

This project investigated the groundwater/surface water interaction at the newly constructed Albuquerque Drinking Water Diversion Dam (DWD) site. The investigation is directed towards developing an understanding of the hydraulic connection between the river, groundwater, the surrounding Bosque soil moisture and the ecological impact as affected by dam presence and operation. The project has three components involving field data collection and analysis:

1. Measure and monitor the groundwater response to dam operation and changes in river flows.
2. Develop a detailed map of the soils and their properties in the Bosque adjacent to the dam.
3. Evaluate the ecological impact of river stage, soil types, and dam operations on the riparian forest.

The following report is divided into three sections to correspond with the topics previously described. Appendices associated with measuring the groundwater and soil properties are provided in appendices as separate electronic files.

2 Measure and Monitor Groundwater Response to Dam Operation and Changes in River Flows

Purpose

This report addresses the second task outlined in the UFDP's "Investigating Groundwater-Surface Water Interaction Above and Below the Albuquerque Drinking Water Diversion Dam." Specifically, this report concerns hydrological monitoring of groundwater wells at four sites that bracket the DWD and the management of generated data to provide insight into groundwater-surface water connectivity. Also included in this report is a description of the monitoring sites, the techniques used to install and manage pressure transducers, and a presentation of groundwater data results from a 6-month period, starting on 22 September 2006 and ending on 31 March 2007.

Groundwater monitoring

The hydrologic portion of the project involves managing 16 groundwater wells installed with pressure transducers (and one barometric pressure logger) at the four sites which bracket the DWD. On the site map (Figure 1), a total of 20 wells are shown in four clusters, with the blacked-out well at three of the sites indicating that these three wells are not installed with pressure transducers. The barometric pressure logger is found at the Bobcat (WU22) north well and is indicated in red.

Each of these wells is equipped with a Solinst Level Logger Model 3001 pressure transducer, which is programmed to record water table levels at 15-min intervals. The well at Minnow (WD12) Center is equipped with a Sutron data logger, which will be described later. The downloaded pressure values of each 15-min data point were then imported to a Microsoft Excel worksheet and into a formula which calculates depth to water table (DWT) and water table elevation (WTE) for each well. This formula will be explained in detail in the later discussion of pressure transducer programming. In addition, effective barometric pressure must be accounted for in this same formula from the pressure readings taken by the barometric data logger.



Figure 1. Site map (aerial photography taken on 26 January 2007).

The U.S. Geological Survey (USGS) maintains river gauge 08329918 at the Alameda Bridge north of the DWD, and gauge 08329928 at the Paseo del Norte Bridge, south of the DWD. These gauges record river gauge height and discharge every 15 min. The groundwater and river data sets are coordinated to time and date at each 15-min interval, creating a database for the purpose of analyzing surface water-groundwater connectivity and interaction in the study area.

Site characterization

The four monitoring sites bracketing the DWD and used for this study are part of the network of the BEMP monitoring sites in the Middle Rio Grande Bosque. A typical BEMP site map of the Diversion (ED10) site is shown in Figure 2.

Since groundwater wells were previously installed at the four monitoring sites bracketing the DWD, these wells were ideal to install with pressure transducers. BEMP has monitored these wells monthly (more often during DWD construction) at the Diversion (ED10) site since July 2002, the Minnow (WD12) site since November 2002, and both the Badger (EU21) and Bobcat (WU22) sites since January 2005.

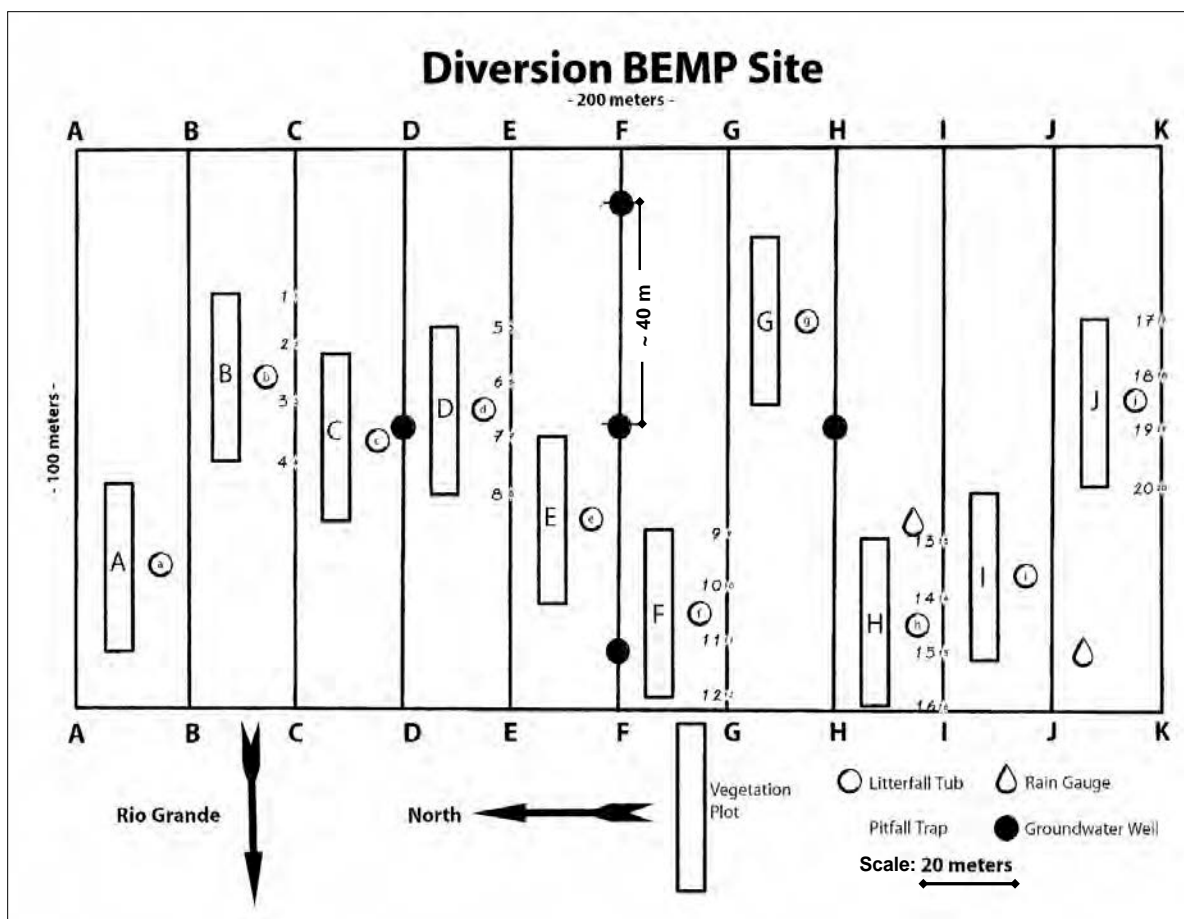

Figure 2. Typical BEMP site map.

Overview of the Bosque Ecosystem Monitoring Program

(BEMP). BEMP is a long-term ecological research program using K-12 teachers and their students to monitor key indicators of structural and functional change in the Middle Rio Grande riparian forest, or “Bosque”. Each year BEMP involves approximately 700 students in year-round data collection and laboratory processing, and about 1,300 students in one-three field/laboratory sessions, helping to increase their understanding and appreciation of science and the ecosystem. Abiotic data collected and analyzed include groundwater; river and ditch water level and quality; precipitation; and temperature. Biotic data include plant productivity and cover, woody debris, and surface-active arthropod activity. These data provide insight into the biological quality and hydrologic connectivity of 23 BEMP sites spanning 280 km of the Middle Rio Grande (Eichhorst et al. 2007).

Well naming system and well installation dates

The naming system for the 16 groundwater wells is a combination of currently-used BEMP site names and descriptive coding that identifies the location of a given well. The names used for all wells in this report will be understandable to the BEMP community, BEMP data processing staff, and UFDP personnel. In the next paragraph is an explanation of the naming system.

Diversion, Minnow, Badger and Bobcat are the BEMP site names that originated with each site's location and placement. The sites were also given a simple number system by BEMP staff based on when they were installed over time. For example, the Diversion site has a number code of 10, for it was the tenth BEMP site set up since 1997. The descriptive coding used in this study to locate each well cluster relative to the DWD is denoted by either: East Upstream (EU), East Downstream (ED), West Upstream (WU) or West Downstream (WD). Thus, the site name of Diversion (ED10) West, refers to the west well at the Diversion monitoring site on the east bank, downstream of the DWD. For the remainder of this report, all wells will be referred to as previously explained.

Table 1 shows four monitoring sites and that their respective dates of groundwater well installation vary over time.

Table 1. Monitoring sites and groundwater well installation.

Well Cluster	Groundwater Well Installation Dates
Diversion (ED10)	July 2002
Minnow (WD12)	November 2002
Badger (EU21)	January 2005
Minnow (WD12)	January 2005

Methods

Groundwater wells

Though the groundwater wells at the four monitoring sites were installed prior to this study, a brief overview of typical well installation is given here. A detailed procedure for well installation can be found in Appendix H.

Shallow groundwater wells at BEMP sites are constructed and located in the same patterns employed for nearly two decades by University of New

Mexico (UNM) researchers studying Middle Rio Grande riparian ecosystem dynamics. Typically, a study site has a cluster of five wells; one center well and four at each cardinal direction. The wells are located 40 m apart from the center well (Figure 2). All four of the sites bracketing the DWD display such a cluster of five, 5.1 cm diam polyvinyl chloride (PVC) wells, hand-augured in place using a 10-cm bucket attachment to a depth of approximately 1 m below the water table. This is done during a period when the adjacent river is at or near base flow. After determining depth to the water table, a length of slotted screen (0.25 mm) pipe is cut so that once inserted to the anticipated final well depth, it will cover all but about 0.5 m of that depth. A drive point is attached to one end of the screen and a 5.1-cm slip coupler to the other end. A length of solid 5.1-cm PVC pipe attached to the top end of the coupler is cut to a length considered appropriate for sufficient above ground well casing exposure. PVC primer and cement are used in all attachments. All parts described here are measured to the nearest centimeter to determine actual well length. (Refer to Appendix H for diagram of a typical well). Once assembled, the entire unit is inserted as far as possible by hand and pounded to the desired depth using a fence post driver that fits over the top of the well casing. Next, silica sand is poured into the gap between the hole and the casing, and tamped down with a rod and shovel handle. A shallow depression is then made at the soil surface around the base of the casing, and a thin layer of bentonite is poured into it. Water is bailed from the well until clear, and then poured over the bentonite to create a seal. The depth to groundwater from the top of the well is then measured, as is the height above ground of the casing. Finally, the well is capped until further use (Figure 3).

Pressure transducers

In anticipation of the DWD construction project, the U.S. Fish and Wildlife Service installed the first groundwater recording device (of the four sites) at the Minnow (WD12) Center well in the form of a Sutron SDI-12 Submersible Pressure Sensor Model 56-113. This sensor was installed on 27 August 2005 and records the groundwater table of this well every 15 min. Since this sensor is vented, there is no need to correct values with an external barometric pressure logger. The U.S. Army Engineer District, Albuquerque, Environmental Resources Section, installed all of the Solinst Level Logger Silver, Model 3001 pressure transducers in the center wells of sites Diversion (ED10), Badger (EU21), and Bobcat (WU22) on 23 November 2005. The three Silver loggers must use the data from the barometric pressure logger installed at BEMP's Rio Grande Nature Center



Figure 3. Typical well casing above ground.

site west well in order to correct the data. This logger was also installed on 23 November 2005. These three center well transducers record in 15-min intervals, but because the barometric logger records in 30-min intervals, all center well data were converted to 30-min intervals. Thus, the data from the three Silver center well transducers is presented separately. At the time of this report, the UFDP staff has taken over the management of the four center wells, and plans to equip them (except for Minnow (WD12) Center with its Sutron logger) with Solinst Level Logger Gold, Model 3001 pressure transducers, to ensure future uniformity of well operations.

The remaining 13 wells were installed with Solinst Level Logger Gold, Model 3001 pressure transducers (Figure 4), along with a single barometric logger. (Refer to Appendix H for a comparison chart of Silver versus Gold loggers.) The first pressure transducer was installed on 31 August 2006 at the Diversion (ED10) East well, while the barometric pressure logger was installed on the same date at the Bobcat (WU22) North well. Because of initial programming and setup issues concerning the loggers and the

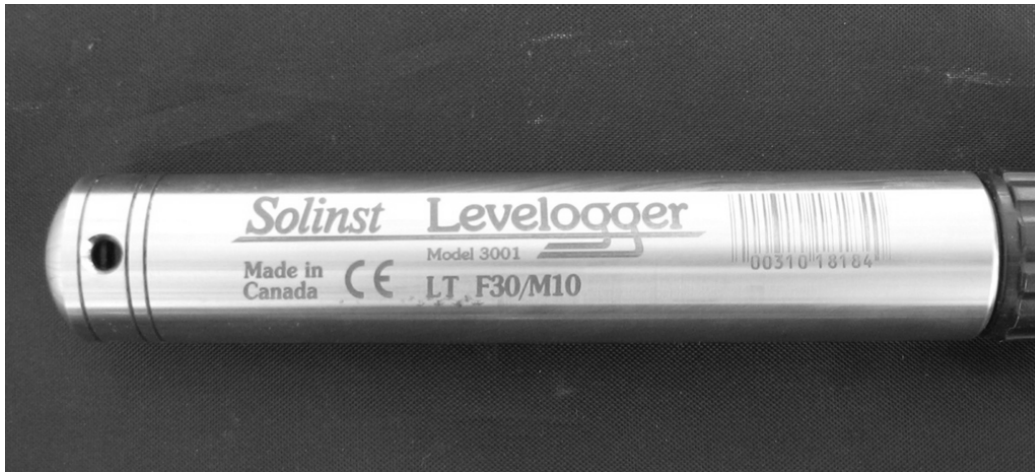

Figure 4. Solinst Gold Model 3001 pressure transducer.

learning curve that comes with newly-issued equipment, the remaining pressure transducers were installed on 22 September 2006, with the exception of the Badger (EU21) East well transducer, which was installed on 28 September 2006. Refer to Appendix H for the logger installation schedule.

Pressure transducer installation procedure and maintenance

This section consists of an overview of the procedure used to install pressure transducers in each well and the programming methods used for each logger. A detailed installation procedure used by BEMP and the UNM Biology Department can be found in Appendix H.

The first step in the transducer installation process is to perform measurements of distance to resistance (DTR) and Direct Read Cable (DRC) suspend length (SL) for each well to be equipped with a transducer. The DTR is the total distance from the top of the well casing above ground to the bottom of the well. The SL is the length of the suspended DRC which the pressure transducer will be attached to inside the well. The DTR is measured by using a Solinst Model 101 Water Level Meter (well beeper) with the beeper sensor turned off (Figure 5).

Step 2 is to suspend the probe into the well until it just makes contact with the well bottom, and read the tape measurement at the beep mark on the top of the well casing. The beep mark is made by carving a notch on the top of the well casing below the well cap and marking this notch in black with a permanent marker to establish a consistent datum by which to measure from each time. These notches also serve as the benchmark from which all groundwater wells were surveyed. The SL should be at least 10 cm above the



Figure 5. Christian LeJeune of UNM with well beeper.

DTR measurement to ensure the transducer is suspended above the well bottom. For example, at the Diversion (ED10) West well, the DTR is 452.0 cm to the bottom of the well, therefore, the SL of the DRC was set to 441.0 cm - about 10 cm above the well bottom. The DRC is the cable used for the SL and has a connection lead near the well top for attaching to a data transfer cable when downloading data (Figure 6). It is best to have the DTR and SL measurements made before attempting to install the loggers in their respective wells. All logger pre-programming should also be done before going out to the field in order to minimize performing these operation in the field where all available resources may not be easily ready for use. In other words, do as much as possible in a favorable working environment to minimize extra work and problems in the field.

Once all DTR and SL measurement are properly set to each logger and the transducers pre-programmed to the extent possible prior to field installation, the loggers are ready to install.

If water from the wells has not been removed during the past year, it is recommended that water be pumped or bailed so that roots may be extracted, if necessary. This will ensure that the wells are working properly and improve confidence in the readings. Since the Silver and Gold pressure



Figure 6. Direct read cable.

transducers both require a barometric pressure logger to correct them, this logger should (if possible) be installed in a well that will not receive a transducer. Ideally, it should be installed on the same day as all the transducers.

Pressure transducer programming

The Levelogger Software Version 3.06 utilized in conjunction with the Solinst Gold transducers is used to view and program logger settings, download and transfer data files to be used for analysis, start new logging sessions after downloading past data, and observe real-time readings in the field. This software is backward-compatible with the older, Silver model loggers installed at three center wells for the study. An example interface of the software used is shown in Figure 8.

At the time of installation, all pressure transducers were programmed to record groundwater levels and temperature every 15 min. This recording increment is preferred, for it can easily be matched up with 15-min-interval river gauge and discharge data from the two USGS river gauges above and below the DWD, in order to compare groundwater and surface water levels. Once all loggers were successfully installed and programmed correctly, a database of 15-min groundwater data at the four sites was started.

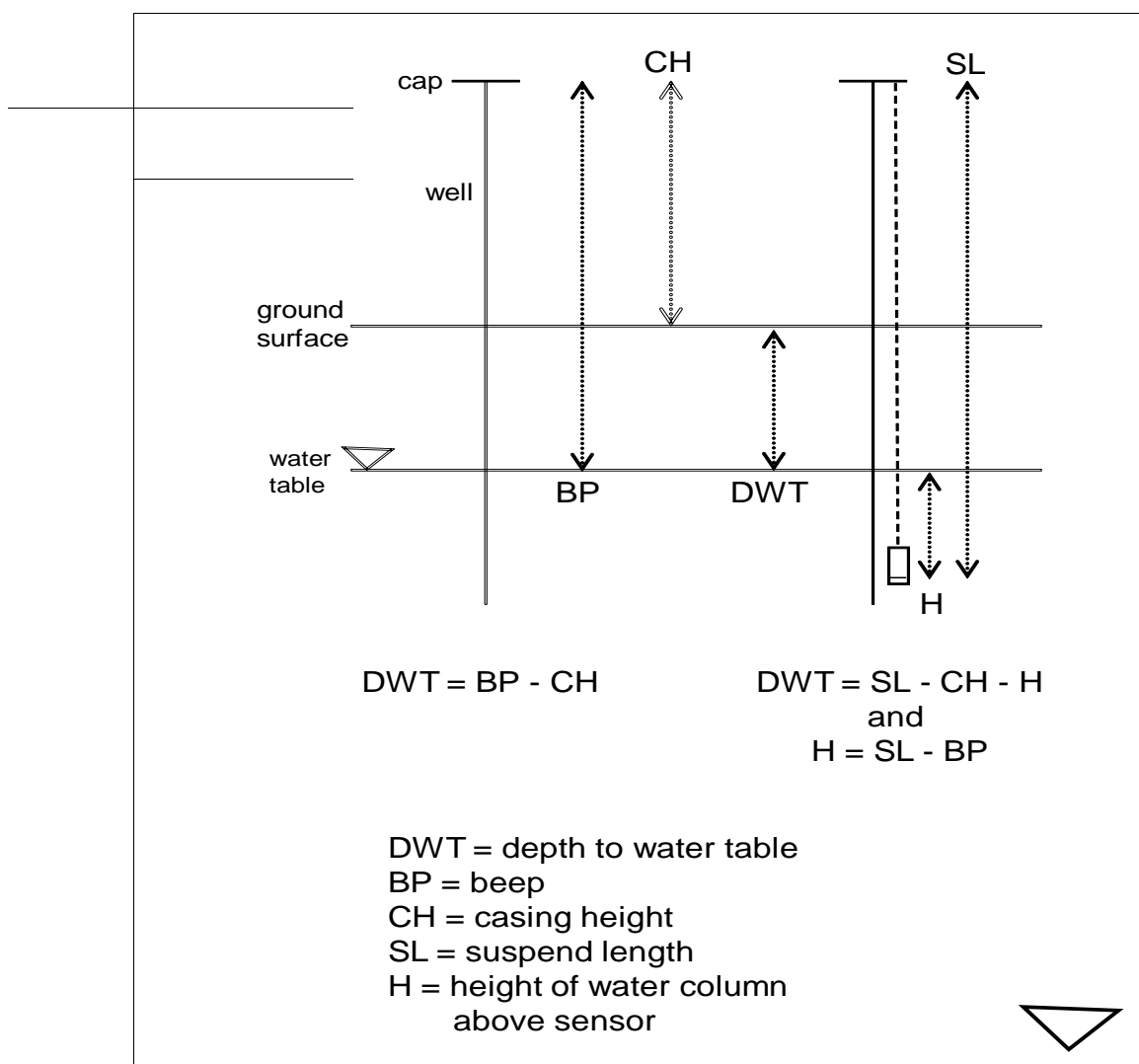

Figure 7. Diagram showing measurements needed to calculate DWT (refer to Appendix H), (Thibault 2006).

Since the logger data do not provide the real measurement of depth to groundwater (because of factors such as accounting for barometric pressure, well casing height above ground and DRC suspend length) the downloaded data files are saved and their data are used in a formula to calculate real DWT and WTE). A sample of the created database and values used to calculate DWT and WTE is shown in Figure 9. This sheet was modified from the original form created by the UNM Biology Department.

In brief, the uncorrected head (head, uncor.), which is the data point recorded by the transducer, has the barometric pressure value subtracted to give the corrected head (corr. head). To determine the actual DWT below ground surface, the corrected head and CH must be subtracted from the SL. WTE can also be easily determined by subtracting the DWT from the well

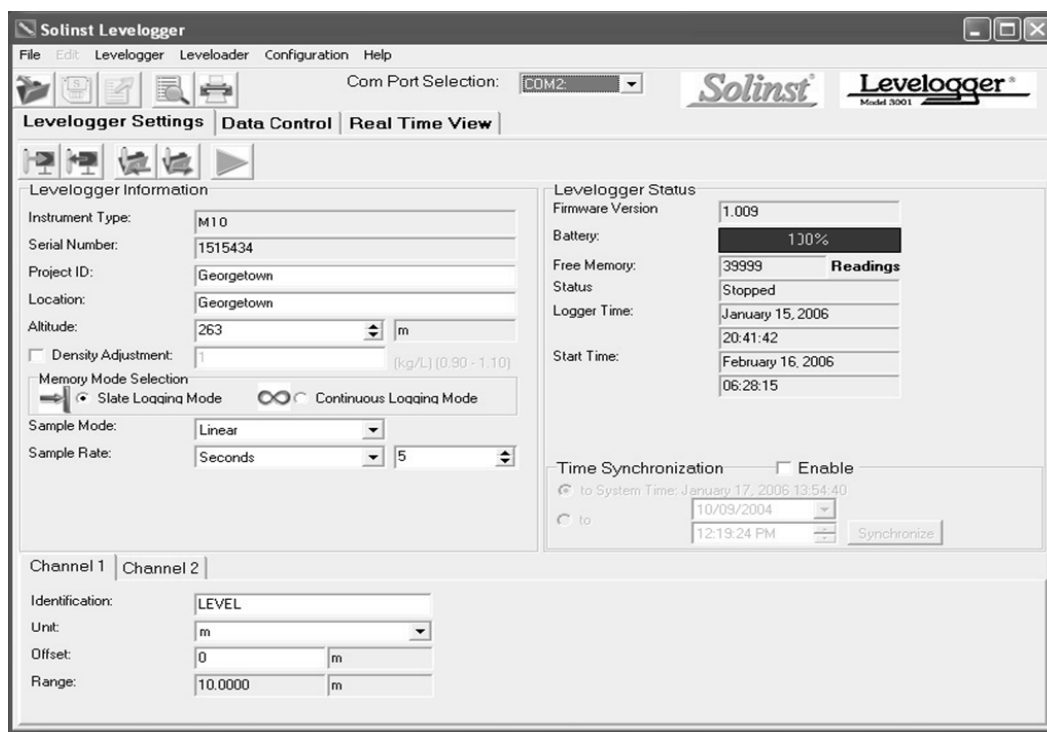

Figure 8. Example interface for Solinst Levelogger Software Version 3.06 (not real data associated with this study).

yr	mo	day	time	well	head, uncor. (cm)	baro (cm)	corr. head (cm)	SL (cm)	CH (cm)	DWT (cm)	well elev. gs (m)	dist (m)	Elevation WT (m)
2006	9	22	20:15	EU21 W	184.86	79.80	105.06	365.0	28.0	231.94	1523.81	2.32	1521.49
2006	9	22	20:30	EU21 W	184.98	79.90	105.08	365.0	28.0	231.92	1523.81	2.32	1521.49
2006	9	22	20:45	EU21 W	185.59	80.40	105.19	365.0	28.0	231.81	1523.81	2.32	1521.49
2006	9	22	21:00	EU21 W	185.75	80.40	105.35	365.0	28.0	231.65	1523.81	2.32	1521.49
2006	9	22	21:15	EU21 W	186.01	80.60	105.41	365.0	28.0	231.59	1523.81	2.32	1521.50
2006	9	22	21:30	EU21 W	186.36	80.80	105.56	365.0	28.0	231.44	1523.81	2.31	1521.50
2006	9	22	21:45	EU21 W	186.57	80.80	105.77	365.0	28.0	231.23	1523.81	2.31	1521.50
2006	9	22	22:00	EU21 W	186.87	81.00	105.87	365.0	28.0	231.13	1523.81	2.31	1521.50
2006	9	22	22:15	EU21 W	185.93	81.20	104.73	365.0	28.0	232.27	1523.81	2.32	1521.49
2006	9	22	22:30	EU21 W	183.02	81.30	101.72	365.0	28.0	235.28	1523.81	2.35	1521.46
2006	9	22	22:45	EU21 W	181.31	81.40	99.91	365.0	28.0	237.09	1523.81	2.37	1521.44
2006	9	22	23:00	EU21 W	180.18	81.60	98.58	365.0	28.0	238.42	1523.81	2.38	1521.43
2006	9	22	23:15	EU21 W	179.04	81.50	97.54	365.0	28.0	239.46	1523.81	2.39	1521.42
2006	9	22	23:30	EU21 W	178.22	81.50	96.72	365.0	28.0	240.28	1523.81	2.40	1521.41
2006	9	22	23:45	EU21 W	177.95	81.80	96.15	365.0	28.0	240.85	1523.81	2.41	1521.40
2006	9	23	0:00	EU21 W	177.22	81.80	95.42	365.0	28.0	241.58	1523.81	2.42	1521.40
2006	9	23	0:15	EU21 W	176.61	81.80	94.81	365.0	28.0	242.19	1523.81	2.42	1521.39
2006	9	23	0:30	EU21 W	176.18	81.80	94.38	365.0	28.0	242.62	1523.81	2.43	1521.39
2006	9	23	0:45	EU21 W	175.55	81.80	93.75	365.0	28.0	243.25	1523.81	2.43	1521.38
2006	9	23	1:00	EU21 W	175.18	81.90	93.28	365.0	28.0	243.72	1523.81	2.44	1521.37
2006	9	23	1:15	EU21 W	174.99	82.00	92.99	365.0	28.0	244.01	1523.81	2.44	1521.37
2006	9	23	1:30	EU21 W	174.60	82.00	92.60	365.0	28.0	244.40	1523.81	2.44	1521.37
2006	9	23	1:45	EU21 W	173.38	82.20	91.18	365.0	28.0	245.82	1523.81	2.46	1521.35
2006	9	23	2:00	EU21 W	171.91	82.20	89.71	365.0	28.0	247.29	1523.81	2.47	1521.34
2006	9	23	2:15	EU21 W	170.37	82.20	88.17	365.0	28.0	248.83	1523.81	2.49	1521.32

Figure 9. Sample database used to calculate DWT and WTE.

elevation at ground surface (well elev. gs). All groundwater wells at the four monitoring sites were surveyed to elevation above mean sea level (MSL) in spring 2007. A table containing all surveyed well values, their respective distances from each other and to river banks can be found in Appendix H. This information will be used in future analysis of groundwater flow patterns in the study area.

A data sheet originally created by Thibault (2006) (Figure 10), and revised for this study is included here, and contains the information and values needed to make necessary calculations to gauge how accurately the loggers are recording data. These data sheets serve the purpose as a manual back-up in validating whether the transducers are working correctly by using the manual well beep distance in a formula to provide how accurately the logger is recording. Loggers should be within 5-cm accuracy when compared to the beep. If off by more, the logger and its programming should be diagnosed and repaired/calibrated accordingly. The Minnow (WD12) Center well is not included on this data sheet because it uses a different instrument and system for recording groundwater levels, and is managed by the U.S. Fish and Wildlife Service.

During the study period of this report (22 September 2006-31 March 2007), a total of 13 site visits were made to download data from the loggers, and to perform necessary maintenance to keep the transducers recording accurately. All of the Gold pressure transducers installed as part of this study were accurate within 1 cm when compared to the manual beep procedure previously explained, with the mean of all loggers within 21 mm of accuracy. The three Silver pressure transducers (older models) found in the center wells at all sites, except Minnow (WD12), were accurate within approximately 2 cm using the beep comparison method, with a mean between the three loggers within approximately 1 cm of accuracy.

Logger maintenance

Routine maintenance that should be performed on at least an annual, if not seasonal basis include: removing the logger from the well and checking all electrical connections and rubber o-rings for signs of water leakage and/or degradation; cleaning the outside of the logger with a cloth; and keeping the circulation sensor bottom hole free of dirt and debris. In addition, the DTR and well casing height should be remeasured annually to track debris accumulation in the wells such as roots and sediments. If the DTR and/or SL should change, these adjustments must be made properly in the field and the new values entered into the database to ensure continuous accurate

Site Name	Diversion	Diversion	Diversion	Diversion	Badger	Badger	Badger	Badger
BEMP Well ID	10n	10w	10c	10e	21s	21w	21c	21e
Date	2-Feb-07	2-Feb-07	2-Feb-07	2-Feb-07	2-Feb-07	2-Feb-07	2-Feb-07	2-Feb-07
Time	1340	1330	1350	1415	1450	1500	1455	1505
Case HT* (CH, cm)	68.0	76.0	55.0	51.0	32.0	28.0	31.0	12.0
Suspend Length (cm)	386.0	441.0	455.0	445.3	440.0	365.0	458.0	378.5
DTR* (Dist to Resist, cm)	398.0	452.0	490.0	458.0	456.0	377.0	466.0	382.0
BEEP (cm)	301.8	286.0	276.5	351.8	328.0	215.3	308.8	321.8
Ht water above PT via well beeper (Hbeep = SL - BEEP, cm)	84.2	155.0	178.5	93.5	112.0	149.7	149.2	56.7
Ht water above PT via sensor reading, uncorrected = (Hsen uncor: cm - last data point)	167.68	236.94	244.50	176.99	195.15	232.59	221.50	139.00
Well elev above msl (wCH, m)	1523.39	1523.83	1523.27	1523.61	1523.68	1524.10	1523.96	1523.49
Effective baro pr (barologger reading) (cm)	82.85	83.05	69.49	82.87	83.20	83.20	69.49	83.39
Ht water above PT via sensor reading, corrected = (Hsen cor = Hsen uncor - eff baro pr, cm)	84.83	153.89	175.01	94.12	111.95	149.39	152.01	55.61
Accuracy = Hbeep - Hsen cor (cm)	-0.6	1.1	3.5	-0.6	0.0	0.3	-2.8	1.1
Levelogger serial #	1018188	1018181	62788	1018152	101851	1018168	62724	1018158
Direct Read Cable serial #	14473	14465	11206	14470	14476	14466	11216	14467
Sample rate (min)	15 min	15 min	15 min	15 min	15 min	15 min	15 min	15 min
Start time	1345	1345	1400	1415	1500	1515	1500	1515
Notes:			rgnc baro				rgnc baro	

Site Name	Minnow	Minnow	Minnow	Bobcat	Bobcat	Bobcat	Bobcat	Bobcat
BEMP Well ID	12n	12w	12e	22w	22c	22e	22s	22nbaro
Date	2-Feb-07	2-Feb-07	2-Feb-07	2-Feb-07	2-Feb-07	2-Feb-07	2-Feb-07	2-Feb-07
Time	1620	1635	1625	1715	1725	1720	1735	1745
Case HT* (CH, cm)	71.0	48.0	53.0	35.0	48.0	35.0	22.0	40.0
Suspend Length (cm)	280.5	367.5	414.0	438.0	435.0	370.0	369.0	n/a
DTR* (Dist to Resist, cm)	297.0	379.0	425.0	449.0	456.0	382.0	384.0	387.0
BEEP (cm)	187.7	207.5	164.5	212.0	174.5	149.8	134.0	185.0
Ht water above PT via well beeper (Hbeep = SL - BEEP, cm)	92.8	160.0	249.5	226.0	260.5	220.2	235.0	...
Ht water above PT via sensor reading, uncorrected = (Hsen uncor: cm - last data point)	175.99	244.21	332.57	311.10	330.50	302.99	317.92	84.02
Well elev above msl (wCH, m)	1523.74	1523.67	1523.55	1524.04	1523.90	1523.92	1523.45	1524.07
Effective baro pr (barologger reading) (cm)	83.17	83.23	83.17	83.46	68.58	83.31	83.73	84.02
Ht water above PT via sensor reading, corrected = (Hsen cor = Hsen uncor - eff baro pr, cm)	92.82	160.98	249.40	227.64	261.92	219.68	234.19	...
Accuracy = Hbeep - Hsen cor (cm)	0.0	-1.0	0.1	-1.6	-1.4	0.5	0.8	...
Levelogger serial #	1018184	1018189	1018167	1018191	62763	1018192	1018150	1017807
Direct Read Cable serial #	14475	14468	14469	14472	11215	14471	14474	14477
Sample rate (min)	15 min	15 min	15 min	15 min	15 min	15 min	15 min	15 min
Start time	1630	1645	1645	1730	1745	1730	1745	1800
Notes:					rgnc baro			

Figure 10. Data collection and verification sheet (Thibault 2006).

readings. If this need arises, it is a good idea to field test the logger and assure that it is operating correctly with the new measurements before leaving (Thibault 2006).

Results

The data generated by the pressure transducers are continuous 15-min groundwater readings for 16 managed wells, and one barometric (baro) logger. The 15-min interval is used to easily correlate groundwater data with USGS river stage and discharge data (also recorded in 15-min intervals), to track groundwater-surface water interactions. Since all the wells were recently surveyed to elevation above MSL) groundwater data are expressed both in DWT and WTE in the database and related graphs and analysis. Recall that the three center wells at the Diversion (ED12), Badger (EU21), and Bobcat (WU22) sites use the older Silver pressure transducers, and must use the barometric logger data from the barologger installed at the BEMP Rio Grande Nature Center (RGNC) monitoring site in order for corrections.

At the time of this writing (May 2007), this database has accumulated over 8 months of data, starting in late September 2006. For the purpose of this report, results presented and analyzed will cover the period of 22 September 2006 through 31 March 2007 (just over 6 months).

The remainder of this report will present groundwater level data from the four sites, with some comparisons to river gauge height from one of the two (or both) USGS gauges above and below the DWD. The main analysis will cover the four wells closest to the river bank at each site: Diversion (ED10) West, Badger (EU21) West, Minnow (WD12) East, and Bobcat (WU22) East. These wells were chosen for this analysis because of their overall general quick response times to river stage fluctuations and DWD trial operations. The DWD trials and operations schedule during the study period can be found in Appendix H, and can be referred to when analyzing graphs.

In Appendix H a series of graphs that show the water table fluctuation and river gauge height associated with each well cluster during the study period. For most graphs, the wells north of the DWD are shown with Alameda Bridge gauge height, while those south of the DWD are shown with Paseo del Norte Bridge gauge data. Because of the ponding effect produced upstream of the DWD during trial operations, the USGS ceased recording discharge rates at the Alameda River gauge on 20 December 2006, to not reflect “false” discharge readings. At the time of this report, the USGS has not surveyed the Alameda or Paseo Bridge river gauges; therefore, the graphs included in this report show only the river gauge heights on the second y-axis, which can be compared to the water table elevations shown on the first y-axis, to get a general sense of groundwater-surface water relationships.

Specific wells missing some data are: Bobcat (WU22) South well, Badger (EU21) East well, and Minnow (WD12) Center well. The first two wells either did not record correctly, or lost data due to issues with programming defects and subsequent software upgrades to repair said defects. The Minnow Center well was not managed by the UFDP during this study period, therefore, insight into the missing data are not readily available at this time.

In comparing the two sites north of the DWD, the 15-min amplitude changes at the Badger (EU21) West well are much greater than those at the Bobcat (WU22) East well. The two sites south of the DWD have similar

15-min amplitude changes, and generally follow the same pattern over time, with the Minnow (WD12) East well having slightly greater response times to groundwater fluctuations (Figure 11).

The graph in Figure 12 represents a 2-week observation period in which there were high flows in the river due to early snowmelt, and 5 days of DWD trail operations. In general, the Bobcat (WU22) East well mimics the Alameda gauge pattern, while the Badger (EU21) West well is not in sync with the Alameda gauge or the other wells. The wells downstream of the DWD generally mimic the Paseo gauge, with the Diversion (ED10) West well pattern being flatter and less responsive than the Minnow (WD12) East well.

Figure 13 represents a 72-hr graph for the four bank wells during a piano-like DWD gate configuration trial. All wells are responsive to DWD operations, with the exception of the Diversion (ED10) West well, which has minimal response. A possible explanation for this pattern is that the end row of the 15-m sheet pilings at the Diversion site are only about 20 m northwest of the ED10 West well. The Badger (EU21) West well again shows the greatest constant response, with the Bobcat (WU) West well responding with greater amplitude changes.

Pre-UFDP well-monitoring and results

The following is an excerpt taken from the Bosque Ecosystem Monitoring Program: Third Supplement: 2004-2005, and presents early groundwater data results during the DWD construction period. (et al. Eichorst, 2004)

“Construction of the DWD started in early 2005. The 15-m sheet pilings were pounded into the riverbed in February (Figure 14). The construction of the dam included pumping groundwater in order to create a sandbar on the west side of the river. The groundwater levels at the sites upstream of the dam, Badger (EU21) and Bobcat (WU22), were not impacted by the construction of the dam (Figure 15). These two sites were set up immediately before dam construction was started, so the well monitoring was increased to three times per week in order to get a better picture of how the water table would respond to construction. Monthly monitoring did not start at these two sites until the third Tuesday of February 2005. Groundwater level recording devices were installed in the center well at each of the four dam sites towards the end of 2005, starting a database of both 15-min and 30 min interval groundwater level readings.

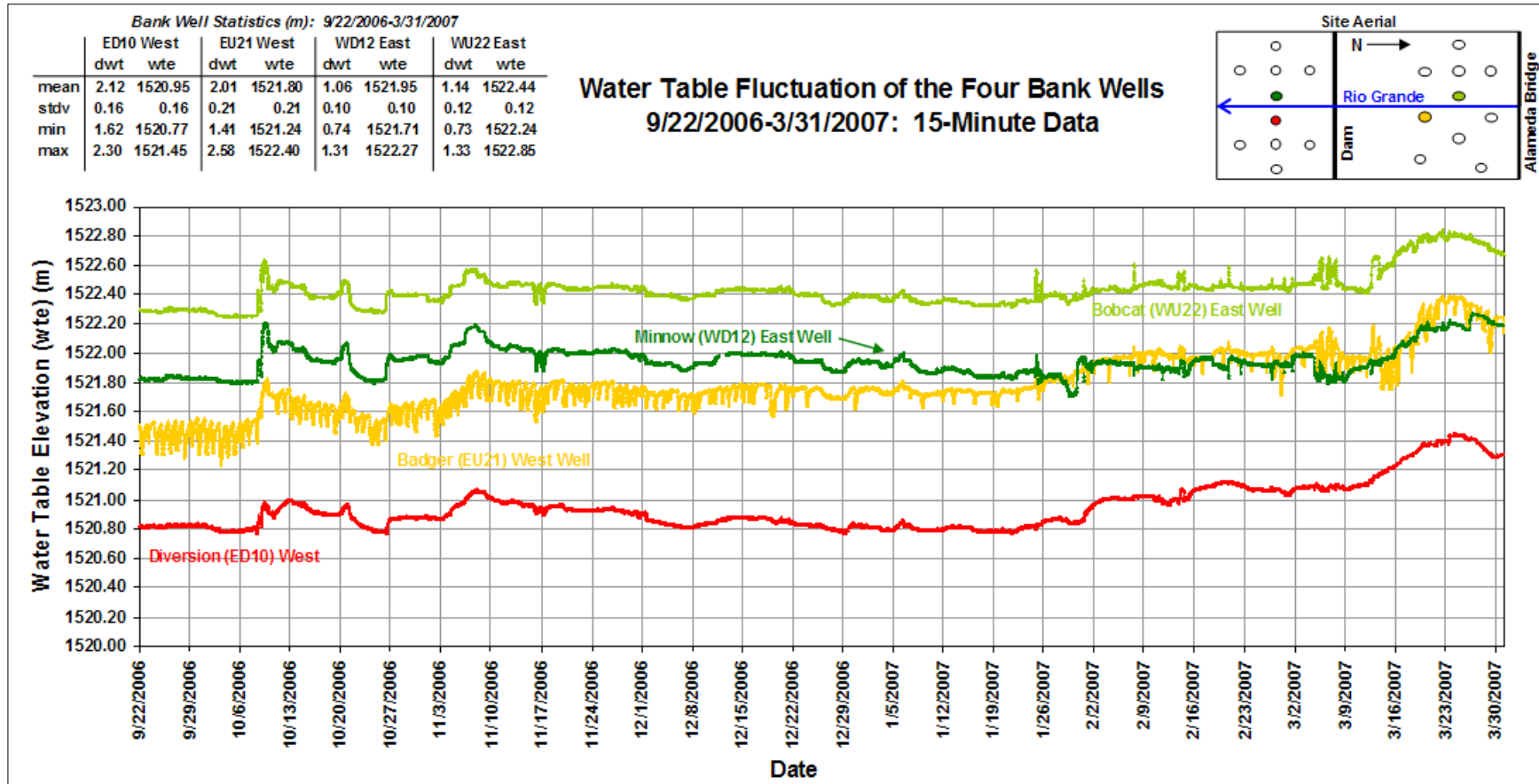

Figure 11. Four bank wells with water table elevation fluctuation.

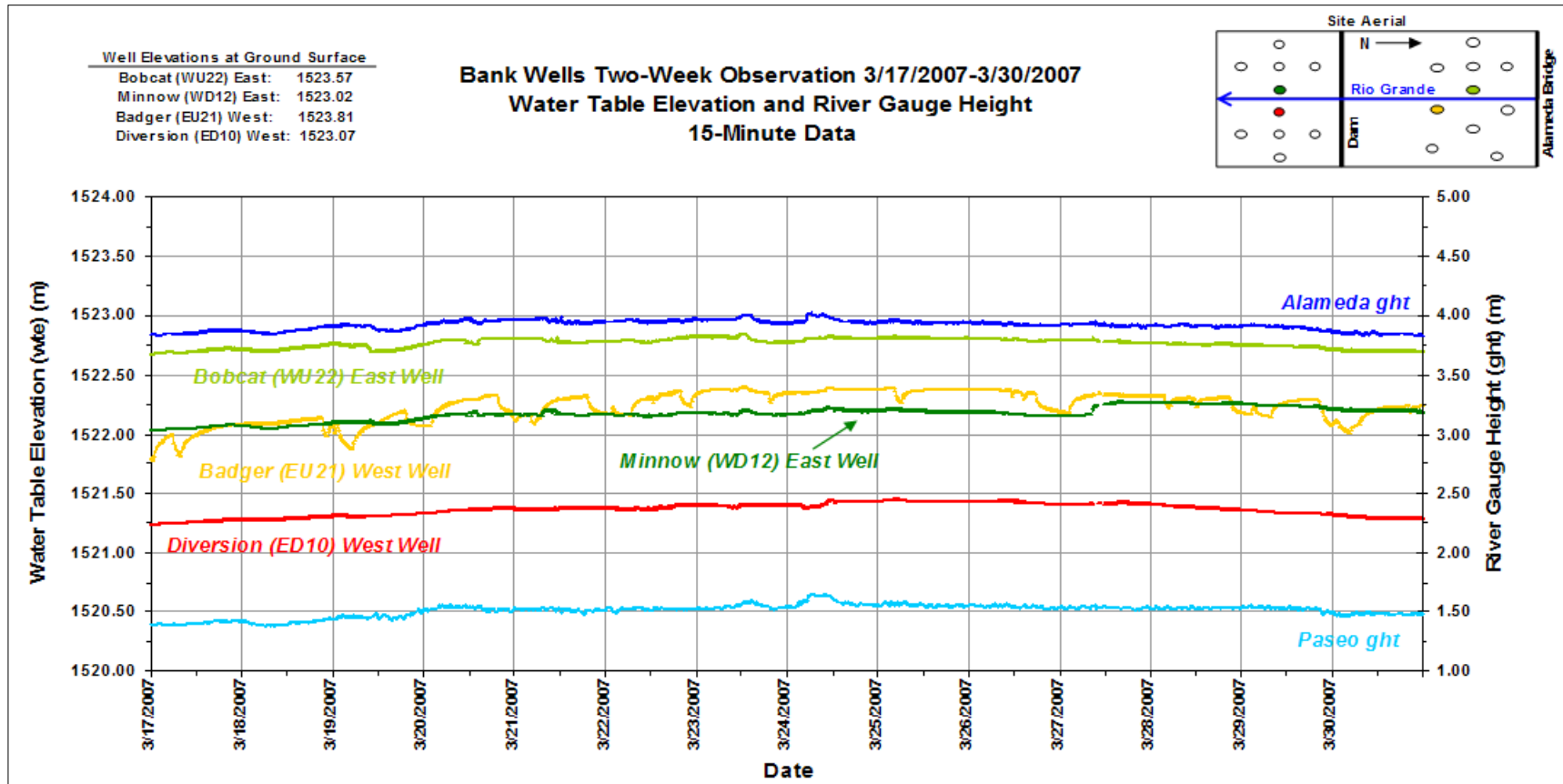

Figure 12. Four bank wells with water table elevation and Alameda and Paseo gauges.

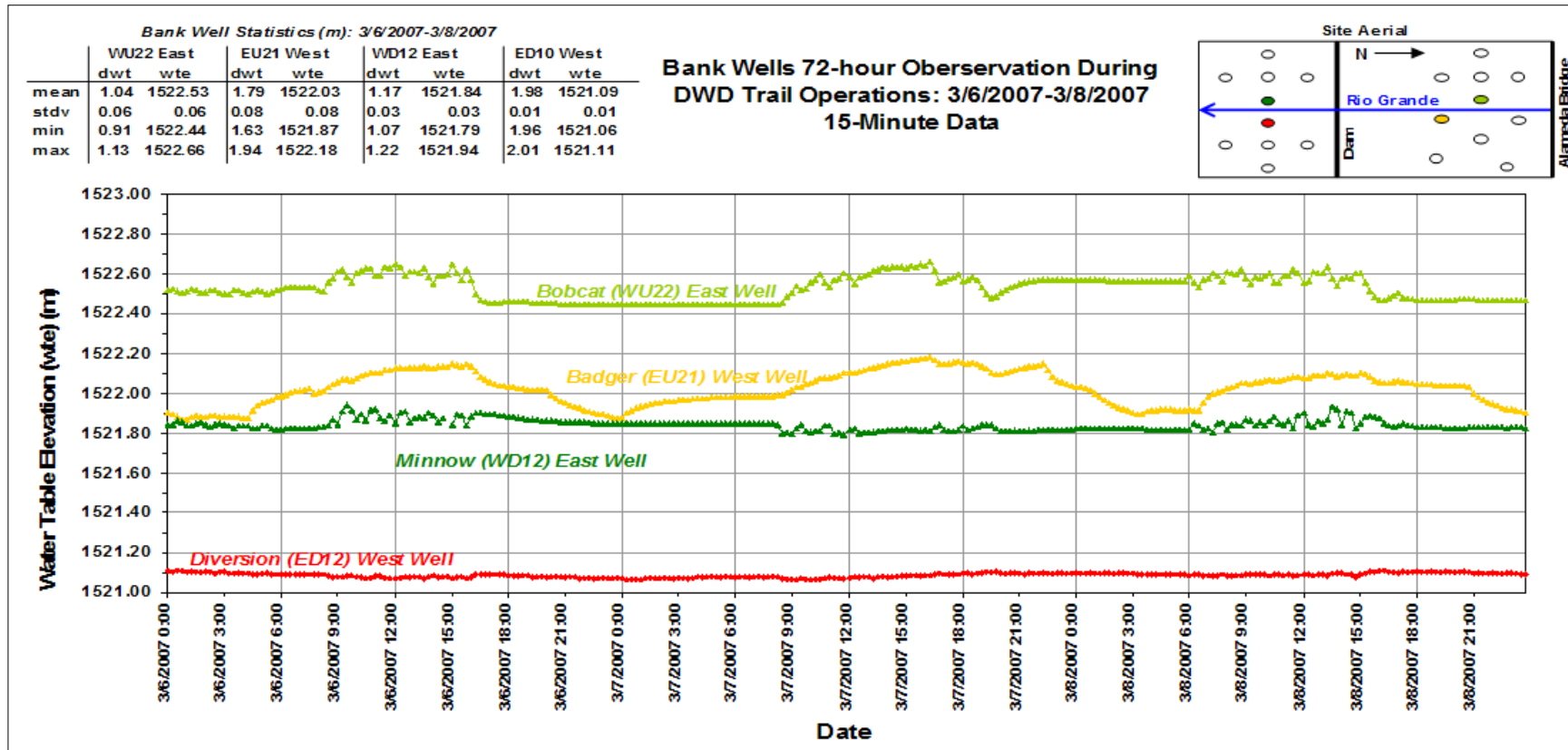

Figure 13. Four bank wells and water table elevation over a 72-hr time period during DWD trial operations.



Figure 14a



Figure 14b

Figure 14. First row of sheet pilings being pounded into riverbed, 9 February 2005.

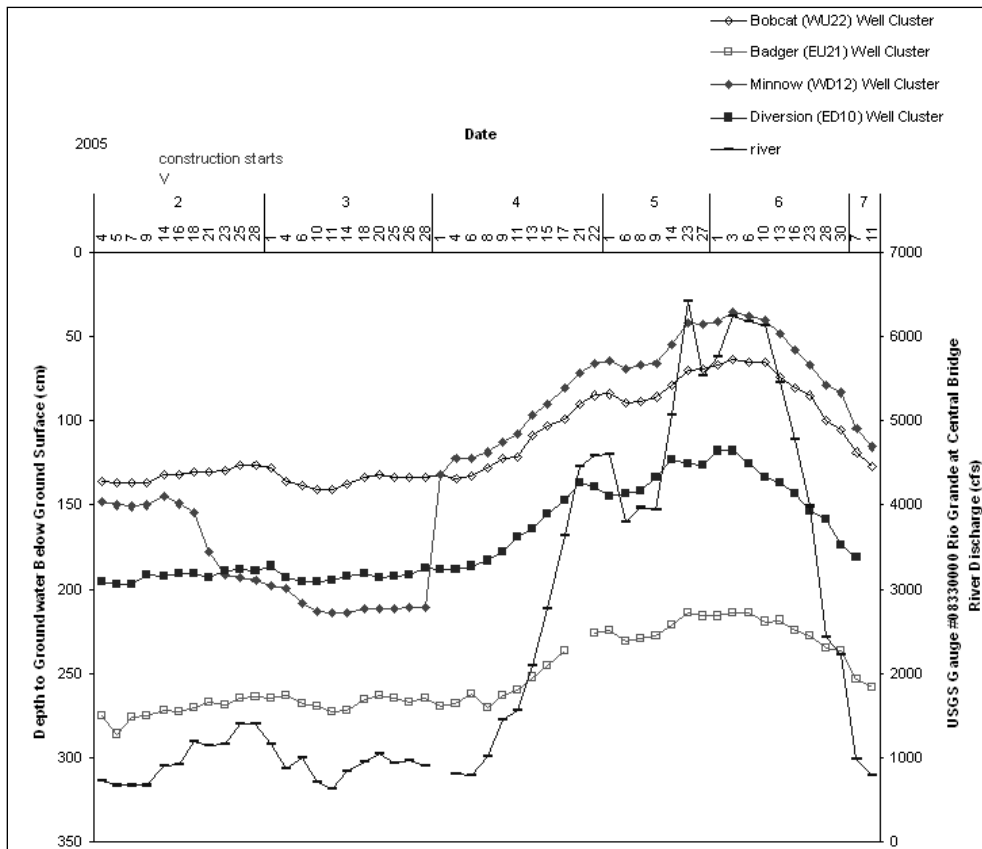

Figure 15. Groundwater depths just above DWD (open symbols: Bobcat (WU22) and Badger (EU21) and just below dam (closed symbols: Minnow (WD12) and Diversion (ED10)). Data are from center wells only (Eichhorst et al. 2006).

The groundwater levels at the two sites directly downstream of the DWD, Diversion (ED10) and Minnow (WD12), responded differently to construction activities (Figures 15 and 16). Minnow (WD12) responded with a significant drop in groundwater levels, from a depth below ground surface of 145 cm to 215 cm (Figure 15). Two of the wells at this site were dry at 235 cm to 250 cm in February and

March 2005. Groundwater levels started to rise just before the increase in river discharge and stayed high for the three months of high river flow (Figure 15). The groundwater levels appeared to stabilize for the 2 months following the post-flooding receding river levels, but then dropped again to below the level of two of the wells for September and October 2005, before again recovering to previous levels (Figure 16).

On the east side of the river, Diversion (ED12), did not respond to the dam’s construction with a drop in groundwater levels (Figure 16). However, once construction on the fish passage started on the east side of the river, the groundwater at Diversion did drop significantly, by over 150 cm, leaving all the wells dry at 381 cm below the ground surface for January 2006, and all but one dry for February 2006 (Figure 16). As of March 2006, all the wells at Diversion again had water (Figure 16).”

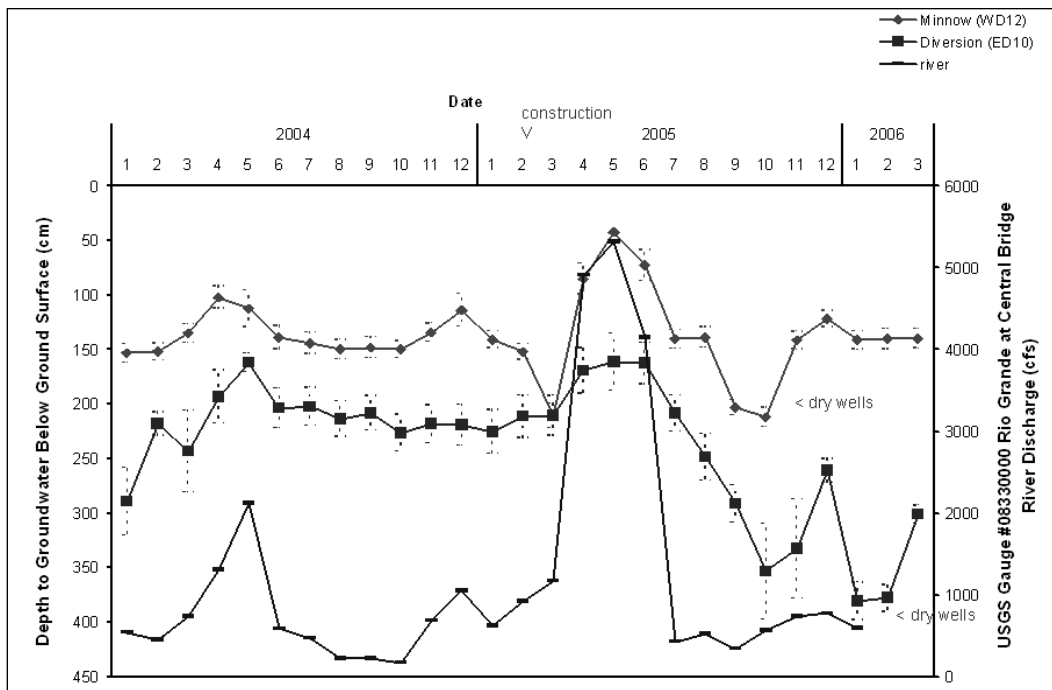

Figure 16. Monthly groundwater depth averages of all five wells at each site below DWD. Minnow (WD12) on west side and Diversion (ED10) on east side of river (Eichhorst et al. 2006).

3 Develop Detailed Map of Soils and Their Properties in Bosque Adjacent to Dam

This chapter addresses the second task of this project investigation. Topics include site characteristics, methodology and results/analysis of the investigation.

Well/core identification

The project investigation will use BEMP site names Minnow and Diversion for the areas downstream of the dam and Bobcat and Badger for the areas upstream of the dam. Our team utilized the following identification system to distinguish between the areas and their corresponding wells/cores.

Minnow (WD12). The first part of the description, previously mentioned, is the name of the area of interest. Within the parenthesis, the first letter (W for west or E for east) corresponds to the side of the river the area is located. The second letter (U for upstream or D for downstream) corresponds to whether the area is upstream or downstream of the diversion dam. The last part of the identification system within the parenthesis is an identification number implemented by BEMP that our team will continue to use. The final description, after the parenthesis, is the location of the well/core within the area of interest.

Identification parameters used throughout the collection of the soil core samples is shown in the following paragraphs.

WCC1 - 0-6.5. The first letter of the acronym corresponds to the side of the river the core is located. The second letter (C for center or N or north) corresponds to whether the core is north or at the center of the overall project area (two more locations were previously thought to be included in this project would have been identified as the southern areas of the project, but were later removed from the project area). The correspondence between this labeling scheme and the BEMP names are as follows: WCxxx (Minnow); WNxxx (Bobcat); ECxxx (Diversion); and ENxxx (Badger).

The third letter is used to identify the soil core's corresponding well (C for center, E for east, etc.). The number following is the soil sample bag

identification and the depth from the surface. All wells/cores will be described using this identification system.

Field investigation

Coring

BEMP has placed a total of 20 groundwater monitoring wells in four distinct areas, each area consisting of five wells, upstream and downstream of the constructed diversion dam (Figure 17). To develop a detailed characterization of the soil in the vicinity of the diversion dam, a total of 19 holes were cored and numerous samples were collected. The coring took place from 25 July to 31 August 2006.

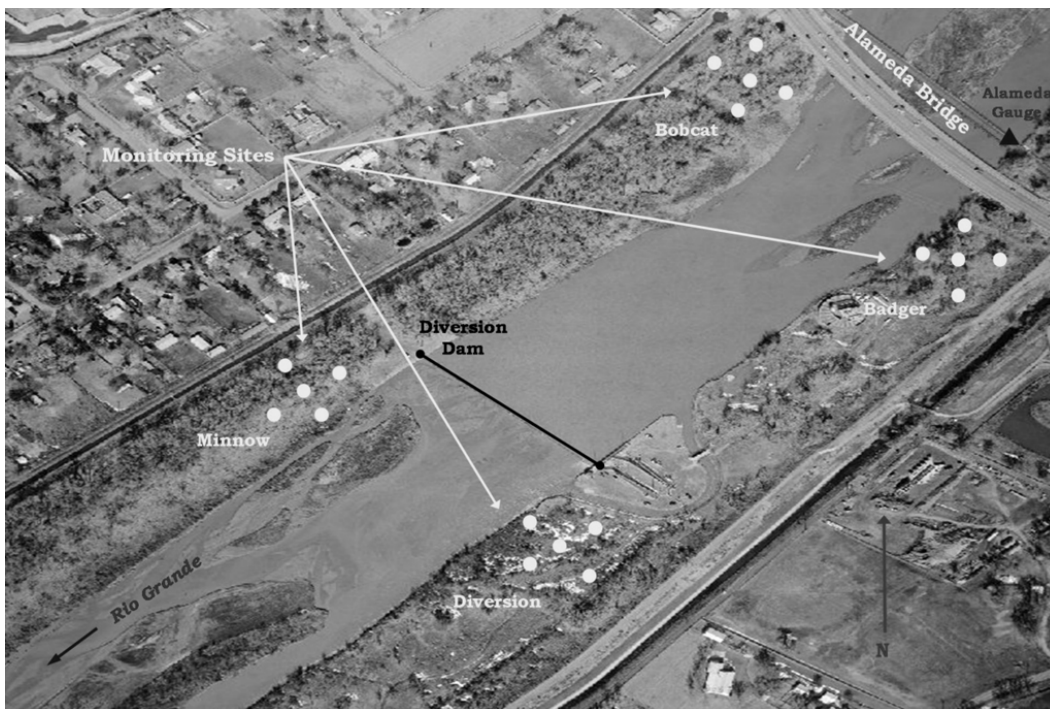

Figure 17. Photograph of study area identifying monitoring site locations where coring took place.

Coring commenced at ground surface and continued until the groundwater table was reached. The terminal depth of these core holes varied from 122 to 300 cm. Coring continued only to the depth of the groundwater table due to loss of hole stability once the water table was reached. The core holes were offset from the existing groundwater wells by 1 m in the southwest direction (Figure 18).

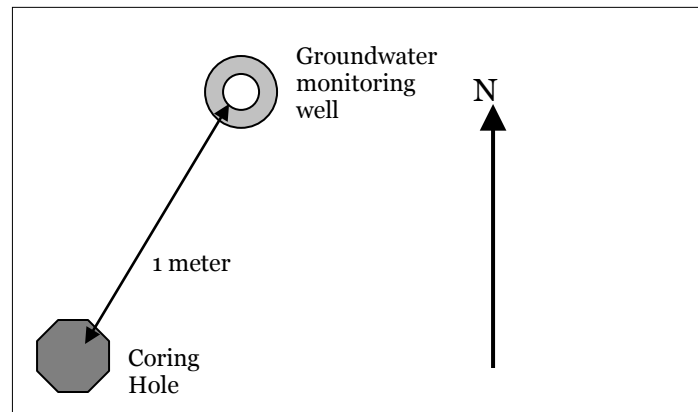

Figure 18. Plan view showing location of core hole relative to existing groundwater monitoring wells.

All soil core samples were documented in the field boring log, photographed, and placed in a soil storage bag to be brought back to the UNM, Civil Engineering Soils Laboratory for subsequent testing.

Visual-manual classification

The soils were first classified in the field using the Visual-Manual Method (ASTM D2488-93) and documented in a field boring log that was created (see “Soils Analysis,” Appendix A). All soil changes (appearance, color, material content, etc.) were also documented on the field boring log and later used to compare with laboratory results. Tests and observations that are associated with the Visual-Manual Method include:

1. Moisture.
2. Color.
3. Dry Strength.
4. Dilatancy.
5. Toughness.
6. Plasticity.

Utilizing all documented material within the field boring log, a preliminary soils layer profile was created. This preliminary soils layer profile was used to determine which soil samples would later be tested in the UNM Soil’s Laboratory.

In-situ density

In-situ density (ASTM D155) testing was performed in the field to determine the in-place density and unit weight of soils using a sand cone

apparatus. The in-situ density is important for subsequent laboratory sample preparation for hydraulic properties testing.

In-situ density tests were conducted on the near-surface soils near the Minnow (WD12) Center and Diversion (ED10) Center locations. Minnow (WD12) Center's first soil layer is classified as a poorly graded sand and has a depth of 0-19 cm from ground surface. Following ASTM Standards, the test calculated a wet density (ρ_{wet}) of 1.25 g/cm³, a wet unit weight (γ_{wet}) of 12.29 kN/m³ and a dry unit weight (γ_{dry}) of 7.02 kN/m³. Diversion (ED10) Center's first soil layer is classified as a clayey sand and has a depth of 0-18 cm from ground surface. Performance of the test calculated a wet density (ρ_{wet}) of 1.57 g/cm³, a wet unit weight (γ_{wet}) of 15.4 kN/m³ and a dry unit weight (γ_{dry}) of 7.9 kN/m³.

Laboratory classification

Soil samples that were brought back to UNM's soil laboratory underwent a series of testing to further classify and substantiate the visual-manual field classification soils layer profile created (Figure 19). Laboratory testing included the Water Content Analysis (ASTM D4959-89), the Particle Size Distribution Analysis (ASTM D2487), the Hydrometer Analysis (ASTM D422-63) and the Atterberg Limits Analysis (ASTM D4318-98).

The Water Content Analysis (ASTM D4959-89) (see "Soils Analysis," Appendices D, E, F, and G) is used to determine the water content within each particular soil layer that was established throughout the visual-manual field classification method. Soil samples were then further tested using the Particle Size Distribution (ASTM D2487) and Hydrometer Analysis (ASTM D422-63) Methods. Both methods cover the quantitative determination of the distribution of particle sizes in the soils collected. The particle size distribution method uses mechanical sieving to classify particle sizes larger than 75 μm (retained on the No. 200 sieve).

Soil samples having 5 percent or greater passing the No. 200 sieve were tested with a hydrometer analysis. The hydrometer analysis method is a sedimentation process that is used to determine particles smaller than 75 μm (passing the No. 200 sieve).

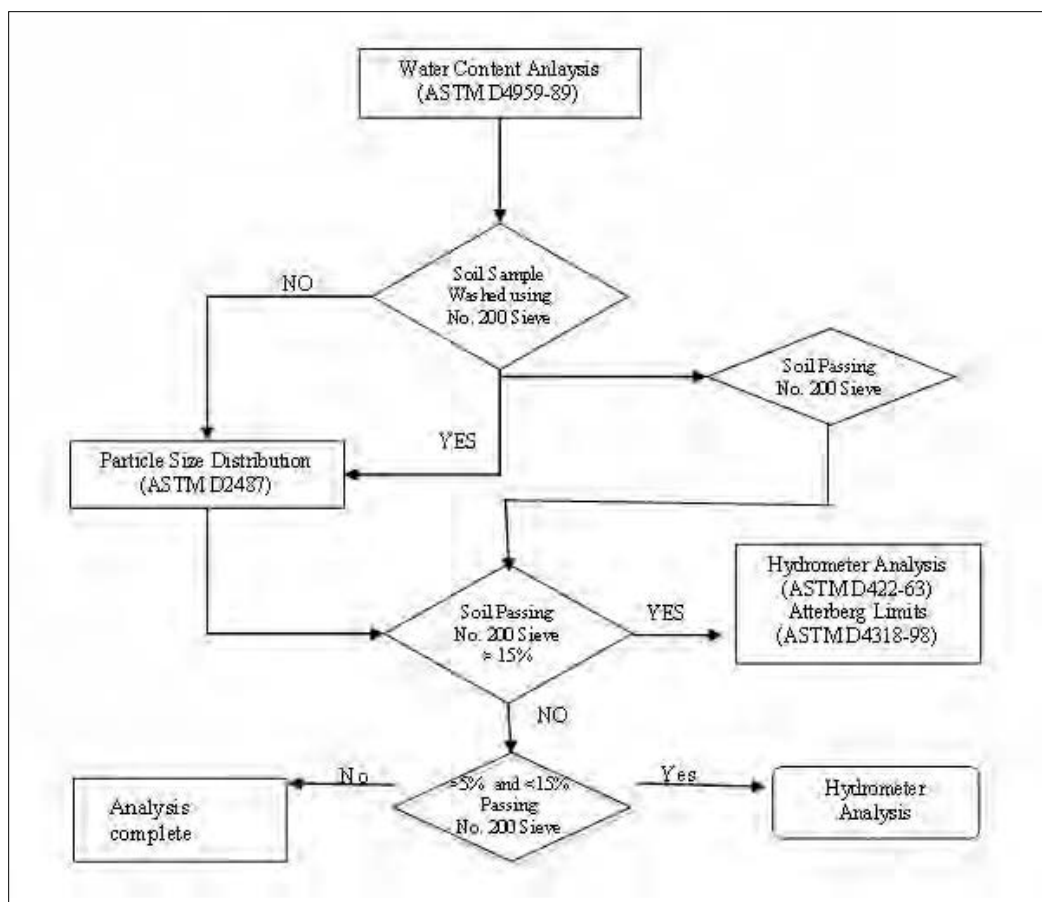

Figure 19. Flow chart of laboratory testing including ASTM standard testing methods.

Atterberg limit testing (ASTM D4318-98) was performed only on select soils with more than 15 percent or more passing the No. 200 sieve. Some of the Atterberg limits tests produced a non-plastic result, shown as NP in Tables B1-B4. For various reasons, such as insufficient quantity of soil, tests were not conducted on many of the soil samples; in these cases, an entry of N/A was made in Tables B1-B4. To aid in the classification of these soils, particle size distribution curves immediately above and below a particular sample were used to determine if the soils had similar particle size distributions. In this case, it was assumed that the soils shared the same properties and that the sample would produce a similar Atterberg limit.

Summary of results

Visual-Manual Method

Utilizing the Visual-Manual Method, which was performed by the same team for the sake of consistency, required additional on-site testing to aid in the field classification of the soils. Field determination of dry strength,

dilatancy, toughness, and plasticity were incorporated into the Visual-Manual Method to field classify the soils. As an example of the results that were obtained, soil profiles for the soil cores taken closest to the bank of the river in each of the four distinct areas are given in Figure 20. Project boring log reports are contained within Appendices D-G.

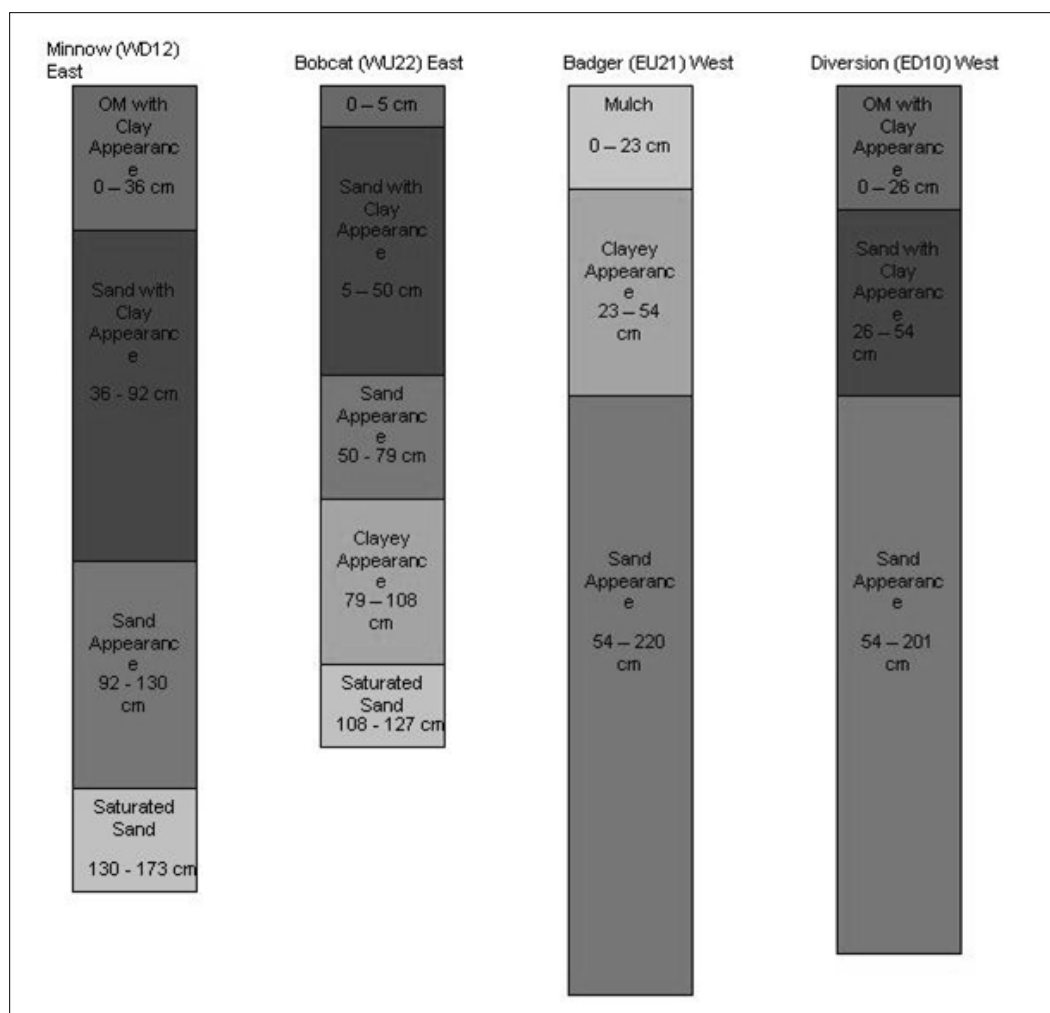

Figure 20. Visual manual classification profiles for four core holes.

Laboratory methods

Soil samples selected through the previously established soil layer profiles and were chosen at certain depths to confirm or, if necessary, change the field classification. Shown in Figure 21 are examples of particle size distributions from soils from the four profiles given in Figure 4.

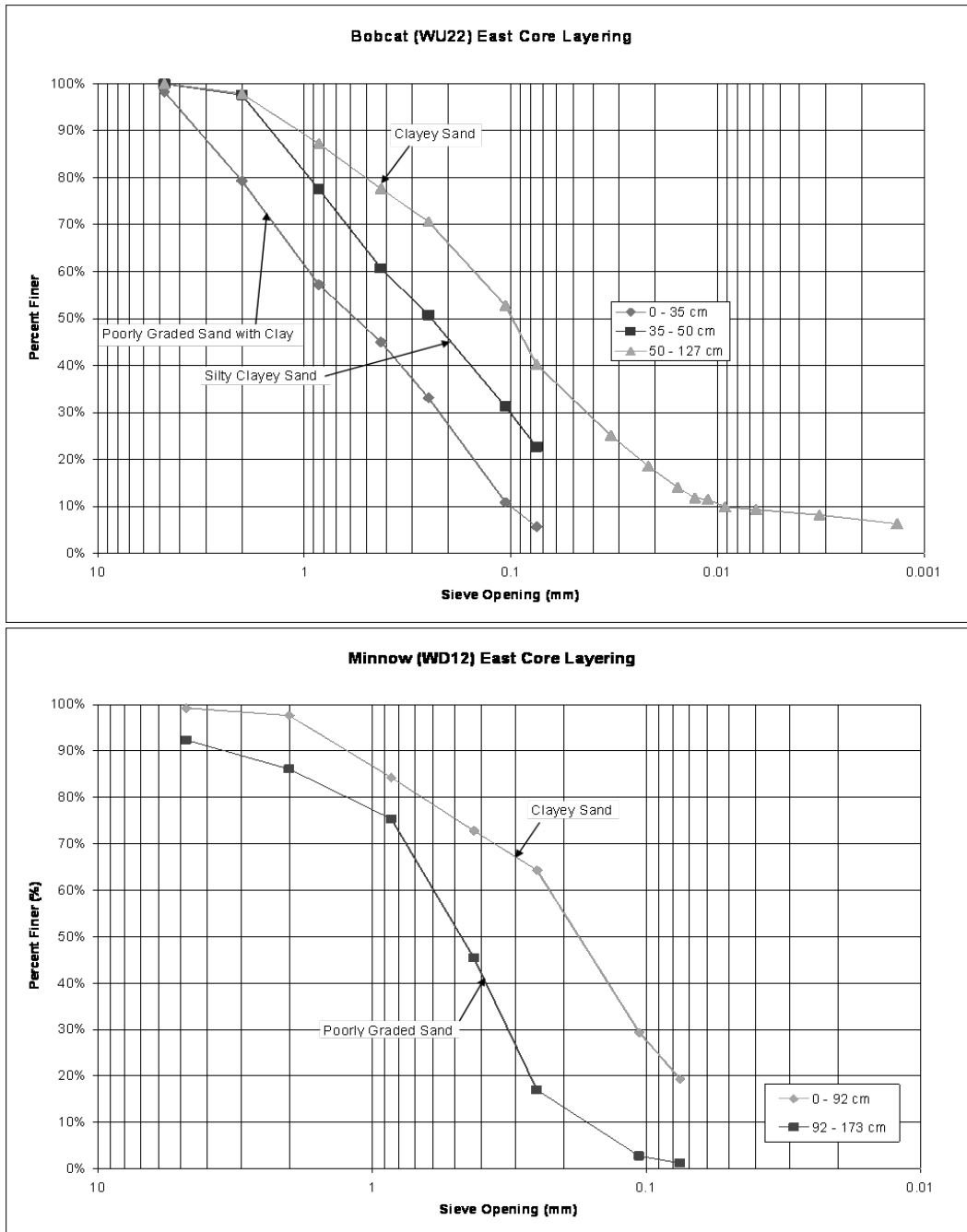
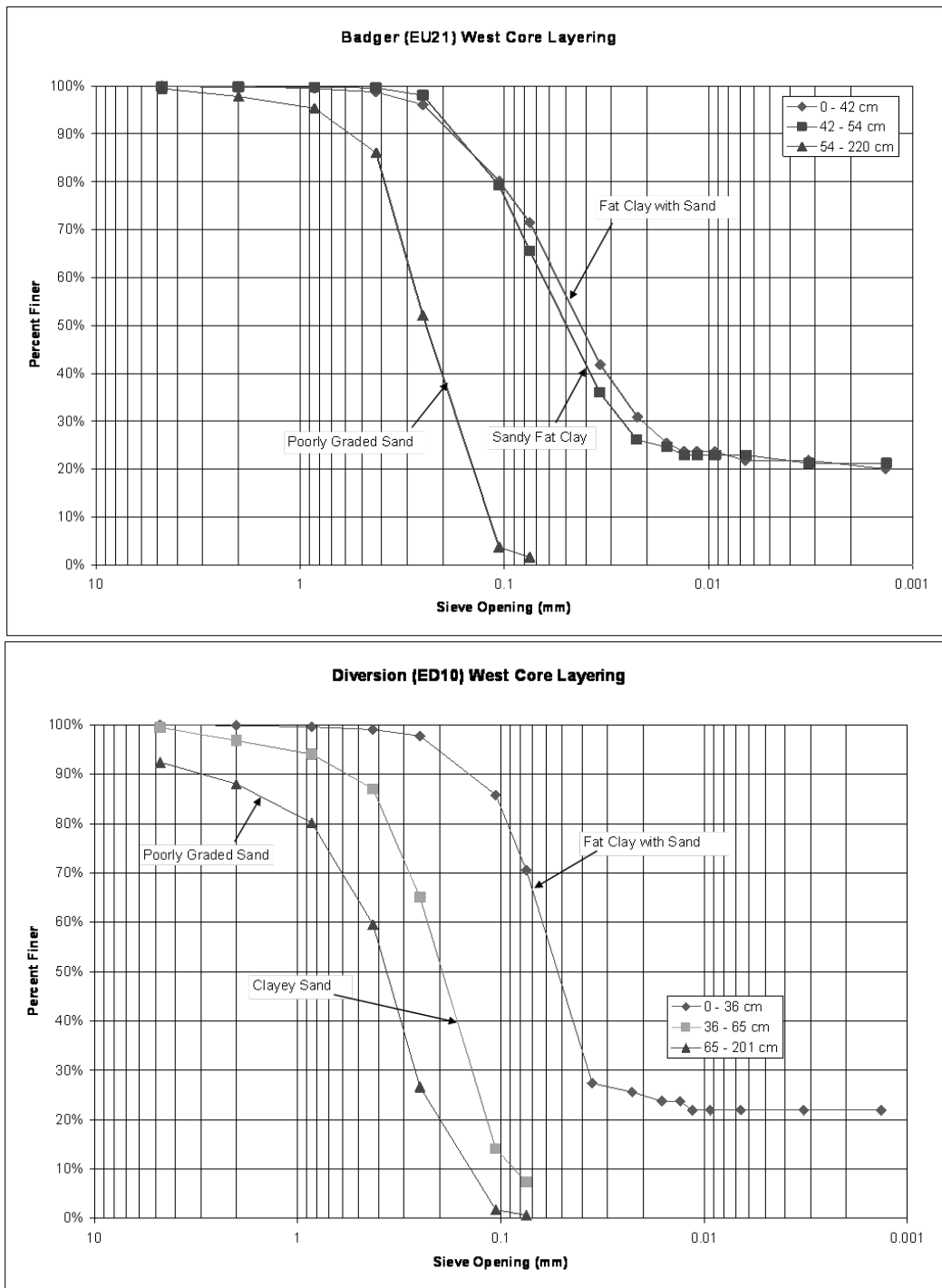

Figure 21. Grain size distribution and classification of soils from four core hole profiles in Figure 20 (continued).



1. Liquid Limit.
2. Plastic Index.
3. Uniformity Coefficient, Cu.
4. Coefficient of Gradation, Cz.
5. Gravel Fraction/Fine Fraction.
6. % of Gravel.
7. % of Sand.

As an example of these data, the Minnow (WD12) Core Layering data sheet is shown in Table B1. Each coring area (North, South, etc.) is associated with a plan number identified in all laboratory tests and corresponds to a specific soil sample bag, as described previously. In certain cases, the Atterberg Limits test were not conducted (shown in each respective column as N/A); as discussed previously, in these cases, information from adjacent samples and the visual manual field classification were used to aid in classification. All project datasheets are located within the appendices.

Figure 22 shows the laboratory-derived soil profiles from core hole locations nearest to the bank of the river for the four distinct areas. These are the same locations given in Figure 20.

The field and laboratory classifications (Figures 20 and 22) indicate a reasonable comparison between the two methods. As expected, the laboratory based method provides more quantitative information.

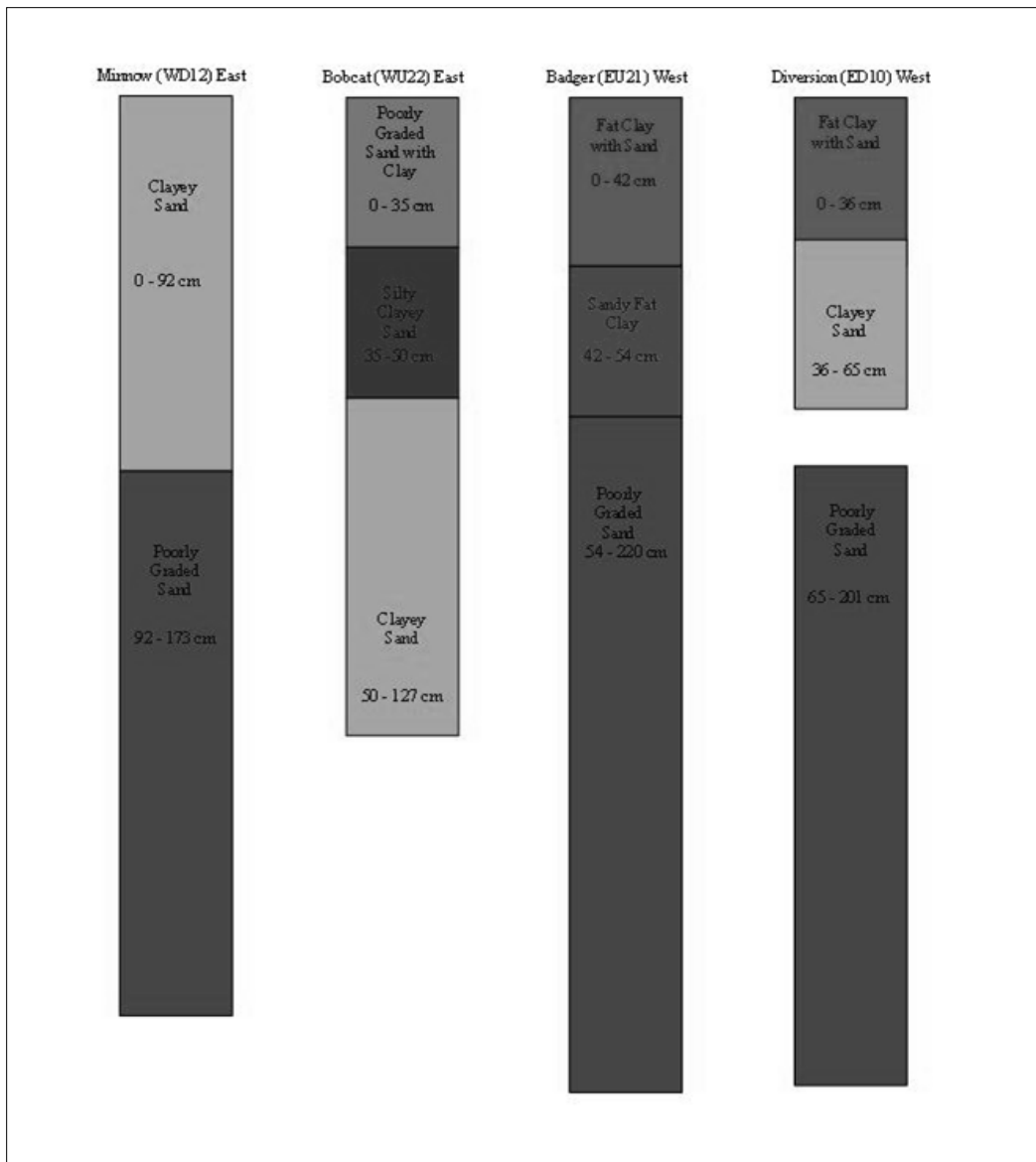

Figure 22. Soil classification of soils from four core holes from laboratory analysis.

4 Evaluate Ecological Impact of River Levels, Soil Types, and Dam Operations on Riparian Forest

Riparian vegetation changes adjacent to Drinking Water Diversion Dam

Introduction

The Urban Flooding Demonstration Project's evaluation of the Drinking Water Diversion Dam's ecological impact on the riparian forest (Bosque) directly above and below the dam was initiated during this first year of funding. It involved measuring plant cover and diversity along annual vegetation transects at each of the four long-term monitoring sites where groundwater/surface water interactions and adjacent soil profiles were characterized simultaneously. The sites and their vegetation are briefly described in the following paragraphs. (The associated hydrology report describes why the sites are coded as shown in this report, and when the sites were installed.)

Site descriptions

Above-dam sites: Badger (EU21), the northeast site, together with its northwest counterpart, Bobcat (WU22), were set up along the lines of typical BEMP sites, except that the lengths of both are half of the usual 200 m. Consequentially, the 10 vegetation plots within those lengths are only 10 m instead of 20 m apart. This occurred because changes in the dam's location were not revealed until several years after the two, now below-dam sites had been installed and originally designated as the above-dam sites; hence their names, Diversion (ED10) and Minnow (WD12). (Otherwise, the distribution patterns of groundwater wells in the two above-dam sites are the same as that shown in Figure 18 of the hydrology report, except that they and the other three sites in this study are between 60 and 80 m in width because of the relatively narrow distance between the river banks and the levees to the east and west.)

Both above-dam sites are dominated by Rio Grande cottonwoods (*Populus deltoides* spp. *wislizenii*). These trees are larger, with heavier trunks, and fewer in number at Badger than at Bobcat, where they appear to be the age

of most mature cottonwoods in the reach (established by the great 1941 and 1942 floods). The large Badger site cottonwoods, which are undergoing branch dieback due possibly to stress by deep-site water table, may be up to a century in age; as are similar appearing cottonwoods elsewhere in the valley. Both sites have a shrub understory now dominated by coyote willows (*Salix exigua*), that tends to occur in dense clusters underneath the large, paired power line poles that run across the river and through the two sites. Invasive Russian olive (*Eleagnus angustifolia*) and Siberian elm (*Ulmus pumila*) were common at both sites until 2006, when they were cleared and removed and/or mulched by Albuquerque Open Space. Grasses and forbs (native and non-native) are patchy in distribution at both sites. The lower, fairly open bank and the higher water table of Bobcat support a small meadow of grasses and sedges along the site's southern bank. No comparable meadow occurs at any of the other three sites bracketing the dam.

Below-dam sites: Diversion (ED10), just southeast of the dam, is lacking the most northern of its original 10 vegetation plots because of the construction of the dam's adjacent fish passage. Therefore, its length is now 180 m. The site was to have been north of the dam, as was the Minnow (WD12) site that is now directly southwest of the dam. Minnow is like Badger and Bobcat in being only 100 m in length.

The cottonwoods of both Diversion and Minnow are mostly mature but not especially large. At Diversion they tend to cluster toward the south, while at Minnow they occur mainly in a line between the levee to the west and the center of the site. Diversion is lined on the east and north by Kellner jetty jacks; they also angle through the site in places and line its banks as well. The bank line at Diversion is lined by them too, likewise making for dense patches of shrubby vegetation adjacent to the river. Coyote willows are more common at Diversion, which in addition had obvious stands of invasive saltcedar (*Tamarix chinensis*) prior to their recent partial clearing. Relatively open areas are present in both sites, again partly as a result of clearing but to some extent an apparent result of topographic undulations caused by human activity; and perhaps earlier by overbanking flows. Grasses and forbs (native and non-native) are present but not striking in appearance at both sites.

Vegetation transect measurements

Transect measurements at the two above-dam sites were made on the following dates:

- Badger (EU21) September 2
- Bobcat (WU22) September 3

Transect measurements at the two below-dam sites were made on the following dates:

- Diversion (ED10) September 4
- Minnow (WD12) September 7

Discussion

Data from these measurements were collected by the professional botanists who monitor all BEMP sites annually. Data were entered into the BEMP database and will be analyzed by BEMP for comparisons of within-year and long-term plant cover and diversity once all other 18 site measurements are also fully entered in the next few months.

The four BEMP sites were similar before dam construction only in the sense that they are individual representations of the highly altered Middle Rio Grande riparian ecosystem. The structure and overall functioning of the ecosystem was driven originally by the Rio Grande's natural flow regime. However, for many decades, flow regulation and invasion by exotic vegetation, together with recent clearing of those exotics and fragmentation by a variety of human activities, has greatly changed the appearance and distribution of the Bosque landscape. The Alameda Bridge immediately north of the upper two sites is but one source of that change. Another is exposure to Bosque entry by thousands of people who continually use the levees that parallel the forest for recreation. Thus, while the purpose of monitoring the vegetation of these BEMP sites is to record how an important and very obvious part of the riparian ecosystem changes at the scale of human use, it is unrealistic to expect that the BEMP protocol for vegetation measurement can selectively define how changes in the flow regime can induce a measurable response in a single recording of 10 30-m transects at each site.

What the protocol can do, however, is provide a starting baseline description of site plant cover and diversity against which changes in those attributes can be compared on an annual basis. Additional human activity and the dynamics of the river flow regime dynamics will further impact the plant communities of the sites bracketing the drinking water diversion dam. BEMP, designed as a long-term monitoring program in 1997, will continue to monitor the effects of these impacts.

5 Conclusions

A successful groundwater monitoring program in the vicinity of the diversion dam has been established as part of this project. The groundwater changes in response to river flow with no appreciable lag time. The deep sheet piles associated with the dam have no effect on depth to groundwater in the riparian area. Because the groundwater is well connected with the river water, the effect of the dam changes the river level by several feet, in turn changing the groundwater level by several feet. This is most pronounced upstream of the dam where the water level is increased to put additional pressure on the intake structure. Additionally, extensive soils analyses have been performed near the well cores. The soils are well layered, as is typical in a riparian area. Clay lenses exist that impede groundwater flow; however, the clay lenses in the area do not appear to have a great extent.

References

- Eichhorst, K. D., D. C. Shaw, J. F. Schuetz, A. D. Gebauer, and C. S. Crawford. 2006. Bosque Ecosystem Monitoring Program (BEMP): Third supplement: 2004-2005. Open-File Report 06-4. 56 pp.
- Eichhorst, K. D., D. C. Shaw, and C. S. Crawford. 2007. The Bosque Ecosystem Monitoring Program/Sevilleta LTER Schoolyard: Combining long-term, monitoring with community outreach. Spring 2007. Citation.

Appendix A: Visual Manual Core Profile

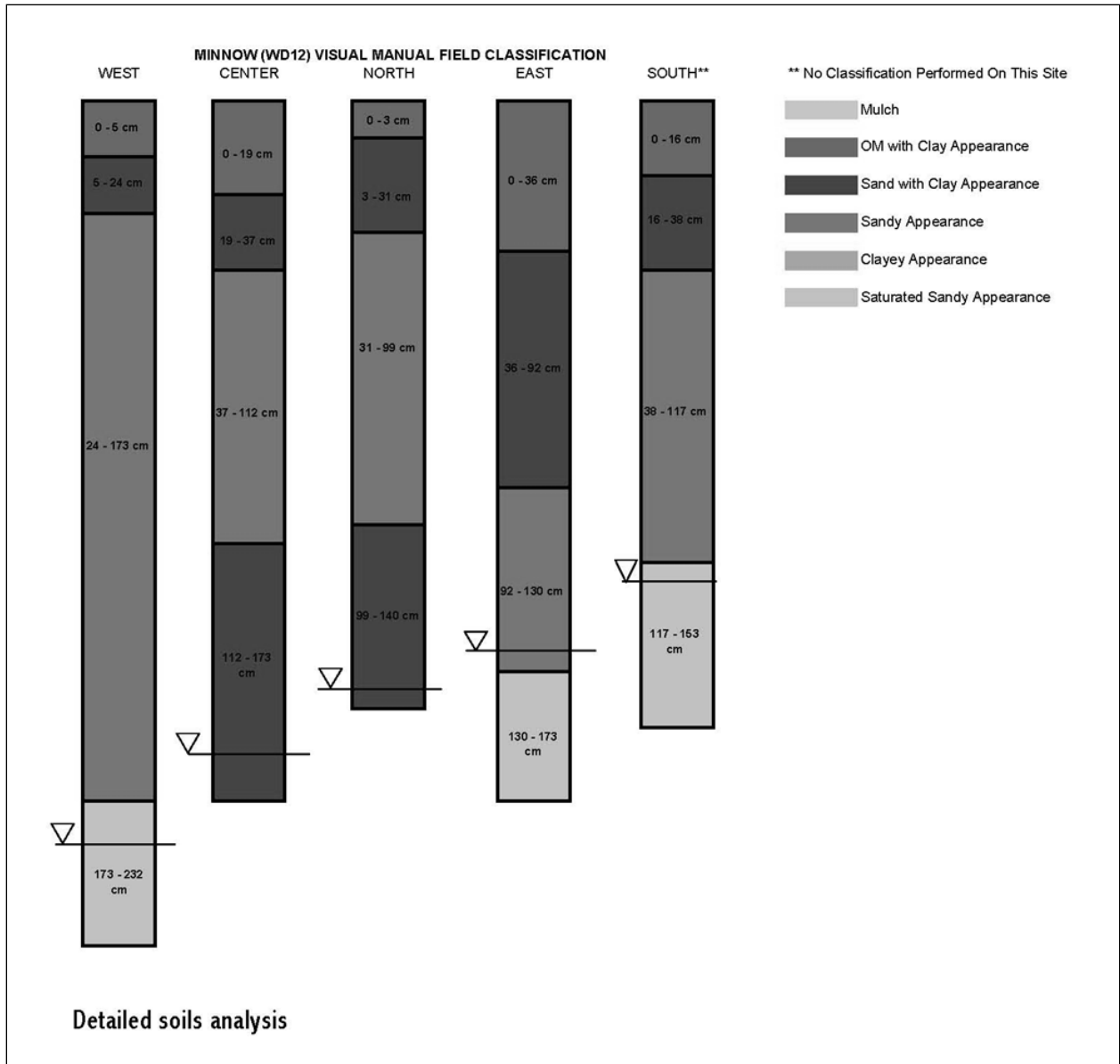

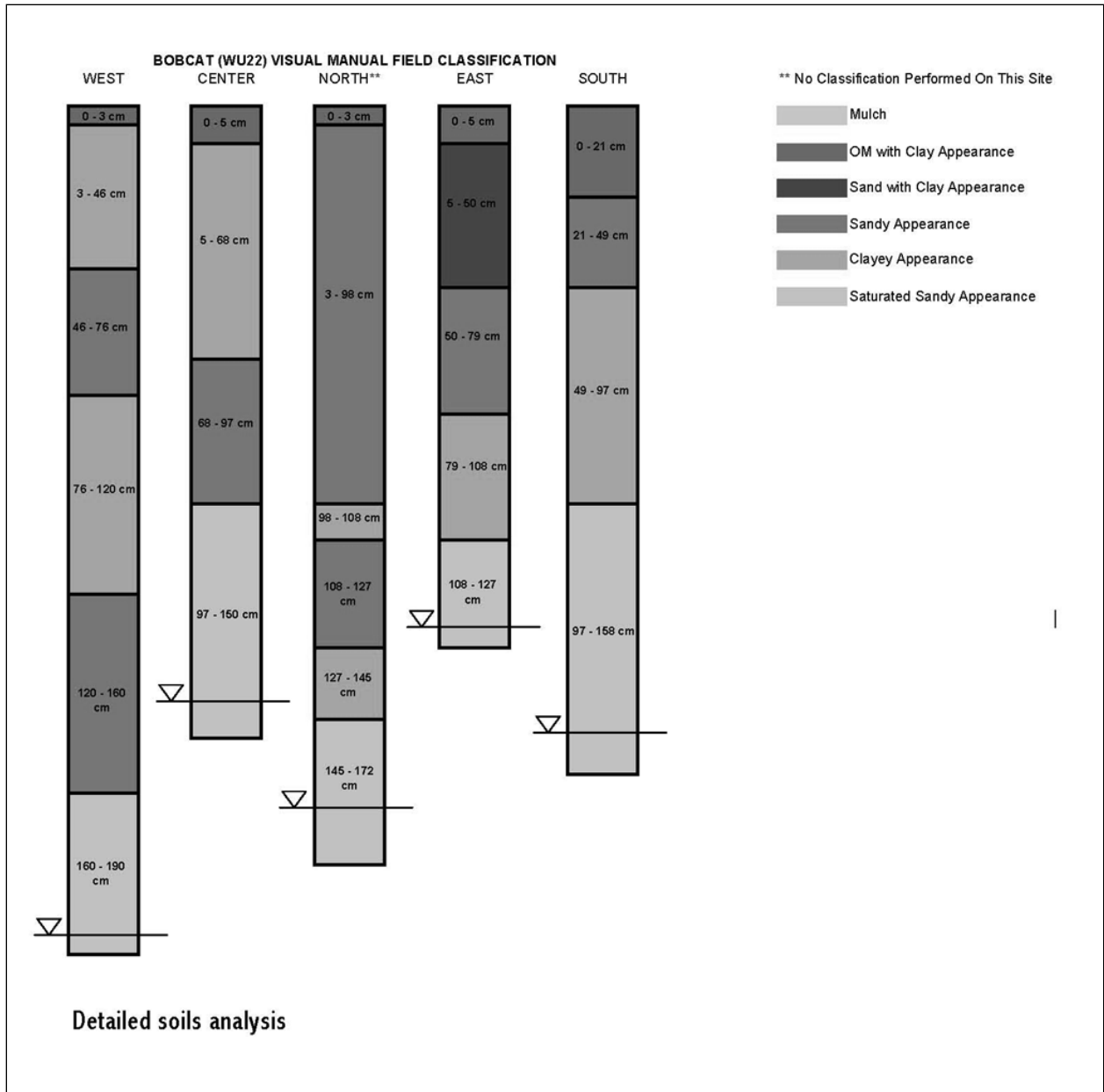

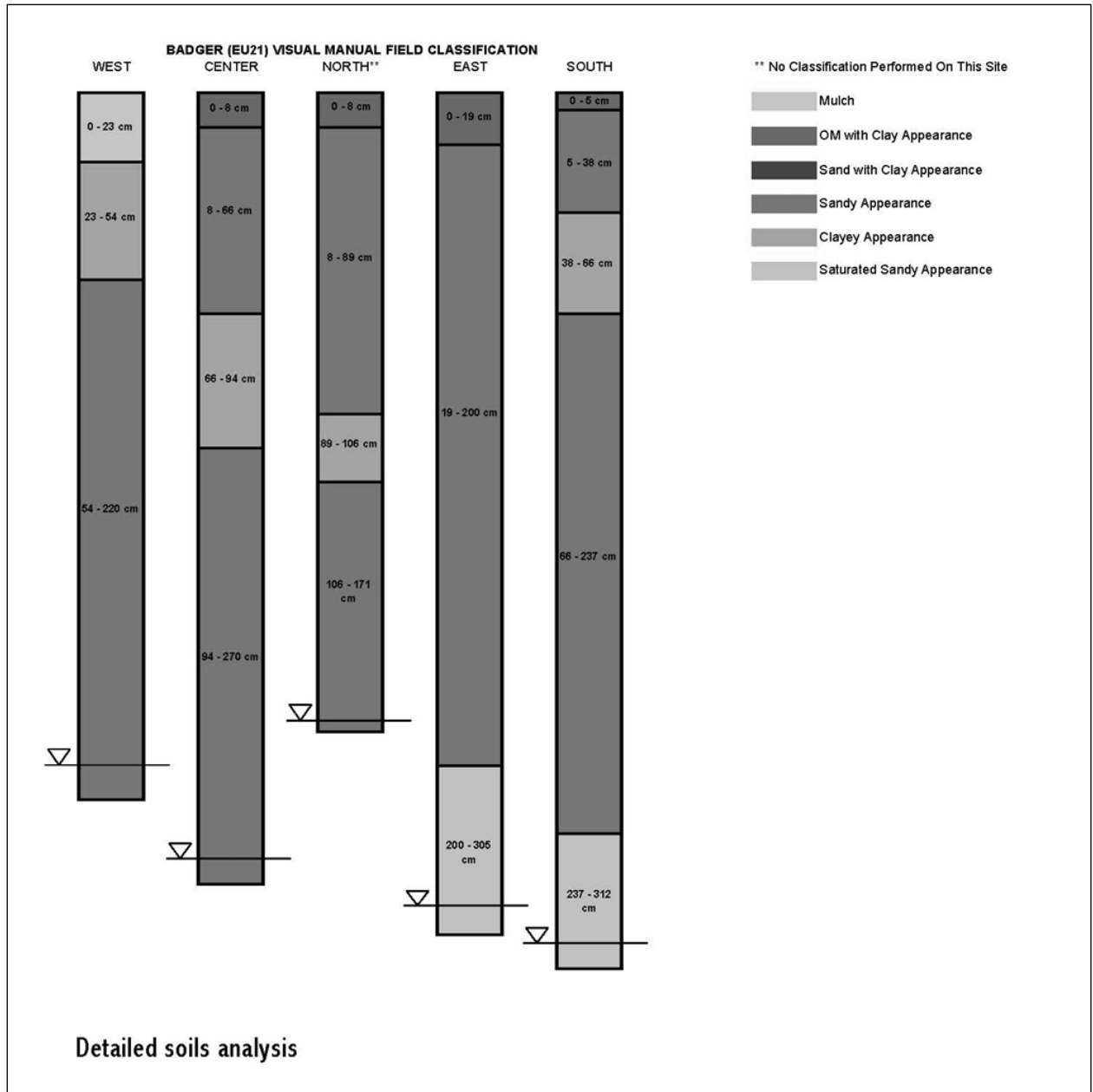

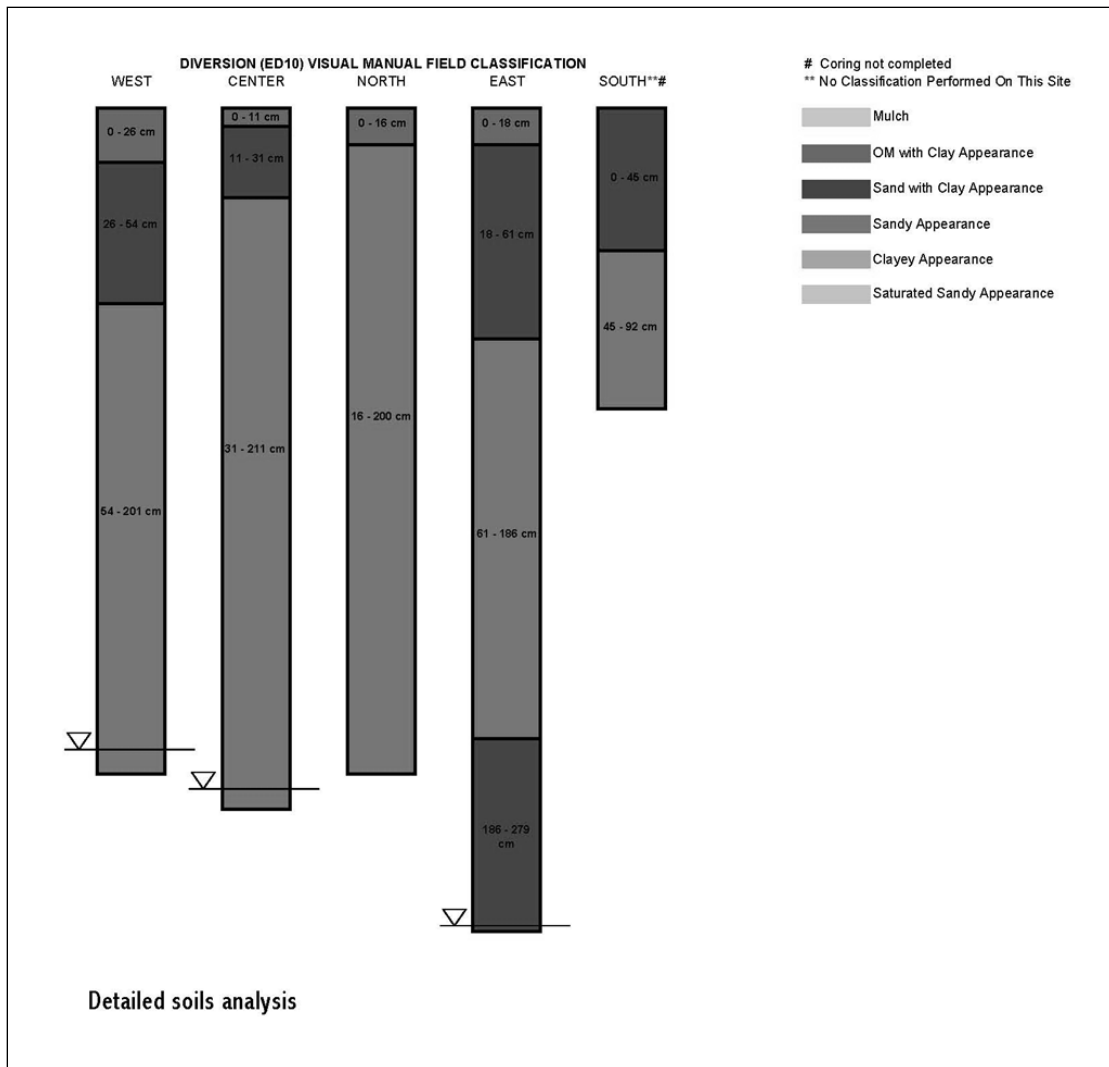

Appendix B: Laboratory Core Profile Data Sheet

MINNOW (WD12) SOIL CORE PROFILE CLASSIFICATION (USCS)

Minnow North	Depth (cm)		C _u	C _c	LL	PI	R _f /R ₂₀₀	% Gravel	% Sand	UCS	Group Name
	From	To									
Pan 7	0.0	2.4	6.7	1.1	NP	NP	0	0	98	SW	Well-Graded Sand
Pan 8	2.4	17.7	9	6.3	N/A	N/A	0.01	1	96	SP	Poorly Graded Sand
Pan 9	30.5	44.5	3.1	1.1	N/A	N/A	0.01	1	93	SP-SC	Poorly Graded Sand with Clay
Pan 10	83.8	99.1	2.2	1.1	N/A	N/A	0	0	94	SP-SC	Poorly Graded Sand with Clay
Pan 11	99.1	115.5	2.5	1.1	N/A	N/A	0	0	98	SP	Poorly Graded Sand
Pan 12	130.8	139.8	2.4	1.2	N/A	N/A	0	0	98	SP	Poorly Graded Sand

Minnow West	Depth (cm)		C _u	C _c	LL	PI	R _f /R ₂₀₀	% Gravel	% Sand	UCS	Group Name
	From	To									
Pan 1	13.4	20.4	0.2	0.1	38	21	0	0	95	SP-SC	Poorly Graded Sand with Clay
Pan 2	24.1	30.5	0.2	0.1	N/A	N/A	0.01	1	84	SC	Clayey Sand
Pan 3	80.2	91.4	0.2	0.1	N/A	N/A	0	0	59	SC	Clayey Sand
Pan 4	142.3	147.2	6.3	0.3	35	15	0	0	85	SC	Clayey Sand
Pan 5	147.2	164.8	7.5	1.8	NP	NP	0.52	51	48	GW	Well-Graded Gravel with Sand
Pan 6	167.6	172.8	7.5	0.8	55	32	0.02	2	92	SP-SC	Poorly Graded Sand with Clay
Pan 7	172.8	180.4	32.5	0.2	45	25	0.2	19	76	SP-SC	Poorly Graded Sand with Clay
Pan 8	192.9	203.3	2.1	1	N/A	N/A	0	0	97	SP-SC	Poorly Graded Sand with Clay
Pan 9	226.2	231.0	2.4	0.9	N/A	N/A	0	0	98	SP-SC	Poorly Graded Sand with Clay

Minnow South	Depth (cm)		C _u	C _c	LL	PI	R _f /R ₂₀₀	% Gravel	% Sand	UCS	Group Name
	From	To									
Pan 8	0.0	10.1	6.78	0.95	52	22	0	0	85	SC	Clayey Sand
Pan 9	15.2	30.5	3	1.04	N/A	N/A	0	0	84	SC	Clayey Sand
Pan 10	43.3	54.6	2.5	0.95	N/A	N/A	0	0	95	SP	Poorly Graded Sand
Pan 11	71.0	85.0	2.29	0.89	NP	NP	0	0	99	SP	Poorly Graded Sand
Pan 12	111.9	116.7	2.17	1.01	N/A	N/A	0.01	1	99	SP	Poorly Graded Sand
Pan 13	116.7	134.7	2.13	1.06	N/A	N/A	0.01	1	99	SP	Poorly Graded Sand
Pan 14	134.7	152.4	2.65	0.54	NP	NP	0	0	89	SP	Poorly Graded Sand

Minnow Center	Depth (cm)		C _u	C _c	LL	PI	R _f /R ₂₀₀	% Gravel	% Sand	UCS	Group Name
	From	To									
Pan 1	0.0	16.5	11.87	0.61	N/A	N/A	0.11	11	85	SP	Poorly Graded Sand
Pan 2	19.2	26.8	16.82	0.91	N/A	N/A	0.07	6	85	SP-SC	Poorly Graded Sand with Clay
Pan 3	36.9	44.5	4	1.11	N/A	N/A	0	0	92	SP-SC	Poorly Graded Sand with Clay
Pan 4	90.2	106.7	2.05	1.13	N/A	N/A	0.04	4	95	SP	Poorly Graded Sand
Pan 5	111.9	124.4	2.06	1.32	N/A	N/A	0	0	99	SP	Poorly Graded Sand
Pan 6	147.2	167.6	2.09	0.44	N/A	N/A	0.02	2	97	SP	Poorly Graded Sand

Minnow East	Depth (cm)		C _u	C _c	LL	PI	R _f /R ₂₀₀	% Gravel	% Sand	UCS	Group Name
	From	To									
Pan 1	0.0	17.7	27.6	0.65	N/A	N/A	0.01	1	74	SC	Clayey Sand
Pan 2	35.7	48.2	3.04	0.69	27	N/A	0	0	82	SC	Clayey Sand
Pan 3	77.4	91.4	2.83	1.53	N/A	N/A	0.01	1	84	SC	Clayey Sand
Pan 4	93.9	105.5	3.11	1.09	N/A	N/A	0.08	8	90	SP	Poorly Graded Sand
Pan 5	110.6	129.6	4	1.06	N/A	N/A	0.06	6	92	SP	Poorly Graded Sand
Pan 6	129.5	150.0	2.63	1.01	N/A	N/A	0.11	11	89	SP	Poorly Graded Sand
Pan 7	167.6	172.8	2.91	1.08	N/A	N/A	0.06	6	83	SP	Poorly Graded Sand

Detailed soils analysis

BOBCAT (WU22) SOIL CORE PROFILE CLASSIFICATION (USCS)

Bobcat North	Depth (cm)		C _u	C _c	LL	PI	R _d /R ₂₀₀	% Gravel	% Sand	UCS	Group Name
	From	To									
Pan 1	0.0	2.4	4.2	1.5	N/A	N/A	0	0	84	SC	Clayey Sand
Pan 2	2.4	19.2	5.8	0.6	N/A	N/A	0.02	2	81	SC	Clayey Sand
Pan 3	54.8	83.4	14.7	1.3	N/A	N/A	0	0	67	SC	Clayey Sand
Pan 4	78.6	83.8	6	0.6	N/A	N/A	0	0	65	SC	Clayey Sand
Pan 5	83.8	92.7	4.4	0.1	N/A	N/A	0	0	65	SC	Clayey Sand
Pan 6	97.8	107.9	50	0.8	45	23	0	0	67	SC	Clayey Sand
Pan 7	107.9	120.7	1600	24.5	N/A	N/A	0	0	67	SC	Clayey Sand
Pan 8	127.1	138.4	22	1.9	67	39	0	0	85	SC	Clayey Sand
Pan 9	144.8	154.8	400	1	N/A	N/A	0	0	77	SC	Clayey Sand

Bobcat West	Depth (cm)		C _u	C _c	LL	PI	R _d /R ₂₀₀	% Gravel	% Sand	UCS	Group Name
	From	To									
Pan 1	0.0	2.4	10	0.6	N/A	N/A	0	0	83	SC	Clayey Sand
Pan 2	2.4	19.2	7.5	0.5	38	18	0	0	71	SC	Clayey Sand
Pan 3	19.2	26.8	5.4	0.5	35	13	0	0	72	SC	Clayey Sand
Pan 4	31.7	46.7	2.9	1	N/A	N/A	0	0	86	SC	Clayey Sand
Pan 5	58.5	69.8	2.2	0.8	N/A	N/A	0	0	50	CL	Sandy Lean Clay
Pan 6	76.2	83.8	3.1	10	47	21	0	0	74	SC	Clayey Sand
Pan 7	89.0	99.1	11.3	1.1	51	20	0	0	80	SW-SC	Well-Graded Sand with Clay
Pan 8	110.6	119.5	3.8	0.8	N/A	N/A	0	0	84	SC	Clayey Sand
Pan 9	119.5	124.4	2.2	0.9	N/A	N/A	0	0	99	SP	Poorly Graded Sand
Pan 10	164.8	180.0	2.8	1.2	N/A	N/A	0	0	90	SP-SC	Poorly Graded Sand with Clay
Pan 11	190.0	171.8	3.6	0.7	N/A	N/A	0	0	72	SC	Clayey Sand

Bobcat South	Depth (cm)		C _u	C _c	LL	PI	R _d /R ₂₀₀	% Gravel	% Sand	UCS	Group Name
	From	To									
Pan 1	0.0	20.4	5.42	0.8	50	22	0	0	80	SC	Clayey Sand
Pan 2	31.7	48.2	6.75	1.81	N/A	N/A	0	0	70	SC	Clayey Sand
Pan 3	48.2	62.2	12.5	34.03	40	20	0	0	73	SC	Clayey Sand
Pan 4	87.8	98.8	undefined	undefined	N/A	N/A	0	0	56	SC	Clayey Sand
Pan 5	96.6	105.5	undefined	undefined	N/A	N/A	0	0	55	SC	Clayey Sand
Pan 6	127.1	147.2	10.88	0.42	45	27	0	0	70	SC	Clayey Sand

Bobcat Center	Depth (cm)		C _u	C _c	LL	PI	R _d /R ₂₀₀	% Gravel	% Sand	UCS	Group Name
	From	To									
Pan 7	0.0	5.2	23.33	1.83	65	30	0	0	83	SC	Clayey Sand
Pan 8	15.2	20.3	21.92	1.87	59	29	0	0	83	SC	Clayey Sand
Pan 9	44.5	57.3	12.35	0.83	N/A	N/A	0	0	88	SP-SC	Poorly Graded Sand with Clay
Pan 10	57.4	78.6	3.75	0.84	N/A	N/A	0	0	78	SC	Clayey Sand
Pan 11	90.2	95.6	29.41	3.4	N/A	N/A	0	0	73	SC	Clayey Sand
Pan 12	95.6	103.0	5.77	0.92	31	-9	0	0	77	SM	Silty Sand
Pan 13	115.5	129.5	10	2.81	N/A	N/A	0	0	82	SC	Clayey Sand

Bobcat East	Depth (cm)		C _u	C _c	LL	PI	R _d /R ₂₀₀	% Gravel	% Sand	UCS	Group Name
	From	To									
Pan 1	0.0	5.2	9	0.59	N/A	N/A	0.01	1	93	SC	Poorly Graded Sand with Clay
Pan 2	5.2	20.4	10	0.51	N/A	N/A	0.03	3	92	SP-SC	Poorly Graded Sand with Clay
Pan 3	34.4	48.7	0.33	0.63	31	5	0	0	77	SM-SC	Silty Clayey Sand
Pan 4	49.7	63.4	5.5	2.2	N/A	N/A	0	0	47	SC	Clayey Sand
Pan 5	75.0	78.8	5.17	1.06	N/A	N/A	0	0	67	SC	Clayey Sand
Pan 6	78.8	90.2	30	1.09	N/A	N/A	0	0	60	SC	Clayey Sand
Pan 7	99.1	107.9	10.91	0.44	41	16	0	0	63	SC	Clayey Sand
Pan 8	116.7	127.1	2.94	0.74	N/A	N/A	0	0	61	SC	Clayey Sand

Detailed soils analysis

BADGER (EU21) SOIL CORE PROFILE CLASSIFICATION (USCS)

Badger North	Depth (cm)		C _u	C _t	LL	PI	R _d /R ₂₀₀	% Gravel	% Sand	UCS	Group Name
	From	To									
Pan 1	0.0	7.6	2.7	1	N/A	N/A	0.01	1	82	SP	Poorly Graded Sand
Pan 2	7.6	20.4	3.1	1.3	N/A	N/A	0.01	1	87	SP	Poorly Graded Sand
Pan 3	53.3	72.6	5.4	1.6	N/A	N/A	0	0	38	CH	Sandy Fat Clay
Pan 4	89.0	105.5	3.6	1.7	N/A	N/A	0	0	27	CH	Sandy Fat Clay
Pan 5	105.5	120.7	3	1.1	N/A	N/A	0	0	82	SC	Clayey Sand
Pan 6	133.5	137.2	3	0.8	N/A	N/A	0	0	81	SC	Clayey Sand
Pan 7	137.2	161.2	2.3	0.8	N/A	N/A	0	0	78	SC	Clayey Sand

Badger West	Depth (cm)		C _u	C _t	LL	PI	R _d /R ₂₀₀	% Gravel	% Sand	UCS	Group Name
	From	To									
Pan 1	22.9	42.1	550	88	N/A	N/A	0	0	29	CH	Fat Clay with Sand
Pan 2	42.1	53.3	550	120.6	N/A	N/A	0	0	34	CH	Sandy Fat Clay
Pan 3	53.3	88.6	1.9	0.9	N/A	N/A	0.02	2	94	SP	Poorly Graded Sand
Pan 4	115.5	2	0.8	N/A	N/A	N/A	0	0	99	SP	Poorly Graded Sand
Pan 5	134.7	150.0	2.1	0.8	NP	NP	0	0	99	SP	Poorly Graded Sand
Pan 6	185.3	200.8	2.4	1.1	N/A	N/A	0	0	99	SP	Poorly Graded Sand

Badger South	Depth (cm)		C _u	C _t	LL	PI	R _d /R ₂₀₀	% Gravel	% Sand	UCS	Group Name
	From	To									
Pan 1	0.0	5.2	10.78	0.58	44	18	0.01	1	75	SC	Clayey Sand
Pan 2	15.2	30.5	3.57	0.82	N/A	N/A	0	0	51	SC	Clayey Sand
Pan 3	43.3	55.8	1.6	1.35	N/A	N/A	0	0	34	CH	Sandy Fat Clay
Pan 4	88.1	78.2	1509	1.09	N/A	N/A	0	0	45	CH	Sandy Fat Clay
Pan 5	103.0	115.5	190	8.42	N/A	N/A	0	0	57	SC	Clayey Sand
Pan 6	129.5	134.7	18.68	1.14	51	27	0	0	81	SC	Clayey Sand
Pan 7	134.7	143.6	4.17	1.31	N/A	N/A	0	0	88	SC	Clayey Sand
Pan 8	161.7	194.5	1.18	1.79	N/A	N/A	0.01	1	56	SP	Poorly Graded Sand
Pan 9	223.4	238.2	2.71	1.27	N/A	N/A	0	0	96	SP	Poorly Graded Sand
Pan 10	238.2	262.7	3.71	0.89	N/A	N/A	0.02	2	97	SP	Poorly Graded Sand
Pan 11	281.8	294.7	5.26	0.95	N/A	N/A	0.15	15	84	SP	Poorly Graded Sand with Gravel

Badger Center	Depth (cm)		C _u	C _t	LL	PI	R _d /R ₂₀₀	% Gravel	% Sand	UCS	Group Name
	From	To									
Pan 8	0.0	7.0	4.29	0.95	N/A	N/A	0	0	66	SC	Clayey Sand
Pan 9	7.6	17.7	5.71	0.8	N/A	N/A	0	0	55	SC	Clayey Sand
Pan 10	48.2	61.0	3.41	1.49	N/A	N/A	0	0	40	CH	Sandy Fat Clay
Pan 11	65.1	72.6	N/A	N/A	51	26	0	0	34	CH	Sandy Fat Clay
Pan 12	88.3	92.9	19	5.81	N/A	N/A	0	0	5	CH	Sandy Fat Clay
Pan 13	97.8	111.9	2	0.95	N/A	N/A	0	0	48	CH	Sandy Fat Clay
Pan 14	124.4	132.0	28.67	2.4	N/A	N/A	0	0	80	SW	Well-Graded Sand
Pan 1	138.4	152.4	2	1.21	N/A	N/A	0	0	94	SP-SC	Poorly Graded Sand with Clay
Pan 2	179.2	192.9	2.98	0.94	N/A	N/A	0	0	98	SP	Poorly Graded Sand
Pan 3	238.2	253.9	2.83	1.05	NP	NP	0	0	99	SP	Poorly Graded Sand

Badger East	Depth (cm)		C _u	C _t	LL	PI	R _d /R ₂₀₀	% Gravel	% Sand	UCS	Group Name
	From	To									
Pan 1	0.0	19.2	30	4.18	N/A	N/A	0	0	40	CH	Sandy Fat Clay
Pan 2	19.2	34.4	5	0.61	N/A	N/A	0.03	1	29	CH	Sandy Fat Clay
Pan 3	34.4	49.7	1500	11.27	N/A	N/A	0	0	12	CH	Sandy Fat Clay
Pan 4	81.0	73.8	17.11	1.46	N/A	N/A	0	0	28	CH	Sandy Fat Clay
Pan 5	95.4	109.1	3000	8.53	N/A	N/A	0	0	25	CH	Sandy Fat Clay
Pan 6	114.3	125.9	5.36	0.98	52	28	0	0	64	CH	Sandy Fat Clay
Pan 7	153.6	187.6	2.4	0.82	N/A	N/A	0	0	97	SP	Poorly Graded Sand
Pan 8	187.6	199.3	1.82	1.19	N/A	N/A	0	0	99	SP	Poorly Graded Sand
Pan 9	199.3	212.1	3.5	1	N/A	N/A	0.08	8	91	SP	Poorly Graded Sand
Pan 10	241.4	253.9	3.44	0.99	N/A	N/A	0.23	23	78	SP	Poorly Graded Sand with Gravel
Pan 11	296.0	304.8	2.36	1.05	N/A	N/A	0	0	99	SP	Poorly Graded Sand

Detailed soils analysis

DIVERSION (ED10) SOIL CORE PROFILE CLASSIFICATION (USCS)

Diversion North	Depth (cm)		C _u	C _z	LL	PI	R _d /R ₂₀₀	% Gravel	% Sand	UCS	Group Name
	From	To									
Pan 1	0.0	15.2	280	2	N/A	N/A	0	0	52	SC	Clayey Sand
Pan 2	19.2	36.9	1.9	1.3	NP	NP	0	0	99	SP	Poorly Graded Sand
Pan 5	115.5	130.8	2.5	1.2	N/A	N/A	0.01	1	99	SP	Poorly Graded Sand
Pan 6	150.0	166.4	3.2	0.8	N/A	N/A	0.09	9	91	SM	Silty Sand
Pan 7	181.7	196.9	2.2	1	NP	NP	0	0	100	SP	Poorly Graded Sand

Diversion West	Depth (cm)		C _u	C _z	LL	PI	R _d /R ₂₀₀	% Gravel	% Sand	UCS	Group Name
	From	To									
Pan 10	0.0	17.7			N/A	N/A	0	0	29	CH	Fat Clay with Sand
Pan 11	35.7	53.3	2.7	1.1	N/A	N/A	0.01	1	92	SC	Clayey Sand
Pan 12	64.9	80.2	2.4	0.9	N/A	N/A	0.02	2	96	SP	Poorly Graded Sand
Pan 13	125.9	137.2	2.8	1.2	N/A	N/A	0.07	7	93	SP	Poorly Graded Sand
Pan 14	171.6	186.8	5.2	0.6	N/A	N/A	0.14	14	86	SP	Poorly Graded Sand

Diversion South**	Depth (cm)		C _u	C _z	LL	PI	R _d /R ₂₀₀	% Gravel	% Sand	UCS	Group Name
	From	To									
	0.0	0.0	#DIV/0!	#DIV/0!	N/A	N/A	#DIV/0!	0	0		

**Unable to collect coring sample

Diversion Center	Depth (cm)		C _u	C _z	LL	PI	R _d /R ₂₀₀	% Gravel	% Sand	UCS	Group Name
	From	To									
Pan 8	0.0	10.1	3.45	1.38	N/A	N/A	0	0	94	SC	Clayey Sand
Pan 9	17.7	30.5	2	0.74	N/A	N/A	0.01	1	98	SP	Poorly Graded Sand
Pan 11	30.5	43.3	1.73	0.94	N/A	N/A	0	0	97	SP	Poorly Graded Sand
Pan 12	96.6	114.3	2.32	0.8	N/A	N/A	0	0	97	SP	Poorly Graded Sand
Pan 13	165.2	180.4	2.21	0.92	NP	NP	0	0	99	SP	Poorly Graded Sand

Diversion East	Depth (cm)		C _u	C _z	LL	PI	R _d /R ₂₀₀	% Gravel	% Sand	UCS	Group Name
	From	To									
Pan 3	0.0	17.7	36.67	12.8	N/A	N/A	0	0	21	CH	Fat Clay with Sand
Pan 4	32.9	43.3	40	5.38	N/A	N/A	0	0	32	CH	Sandy Fat Clay
Pan 5	61.0	80.2	2.69	0.99	N/A	N/A	0	0	85	SC	Clayey Sand
Pan 6	130.8	152.4	2.4	1.35	N/A	N/A	0	0	90	SC	Clayey Sand
Pan 7	170.1	185.3	2.22	1.09	N/A	N/A	0	0	94	SC	Clayey Sand
Pan 8	185.3	203.3	2.27	0.93	N/A	N/A	0	0	97	SP	Poorly Graded Sand
Pan 9	253.9	269.1	2.56	1	N/A	N/A	0.03	3	95	SP	Poorly Graded Sand

**South Core was unable to be completed due to core instability.

Detailed soils analysis

Appendix C: Laboratory Core Profile

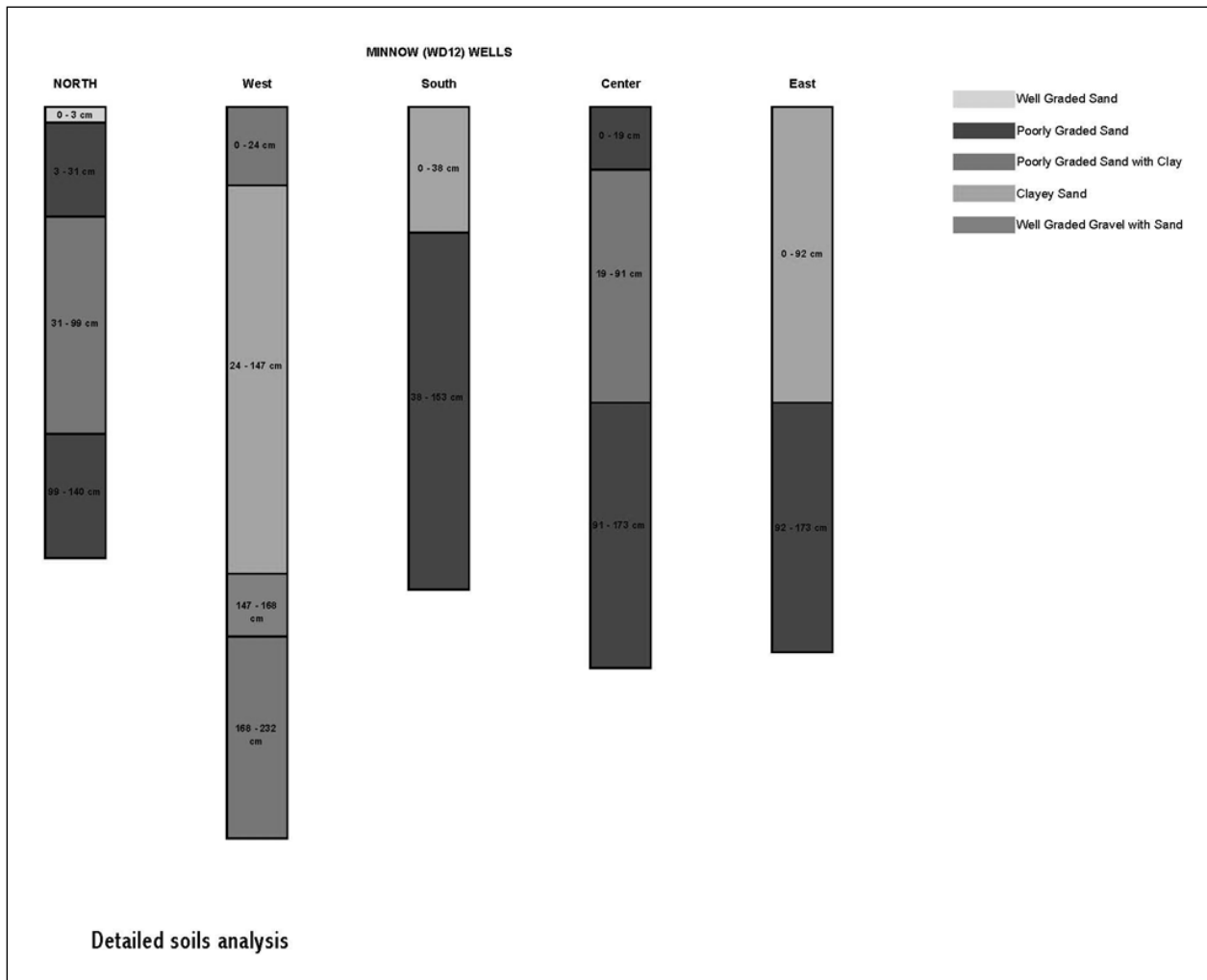

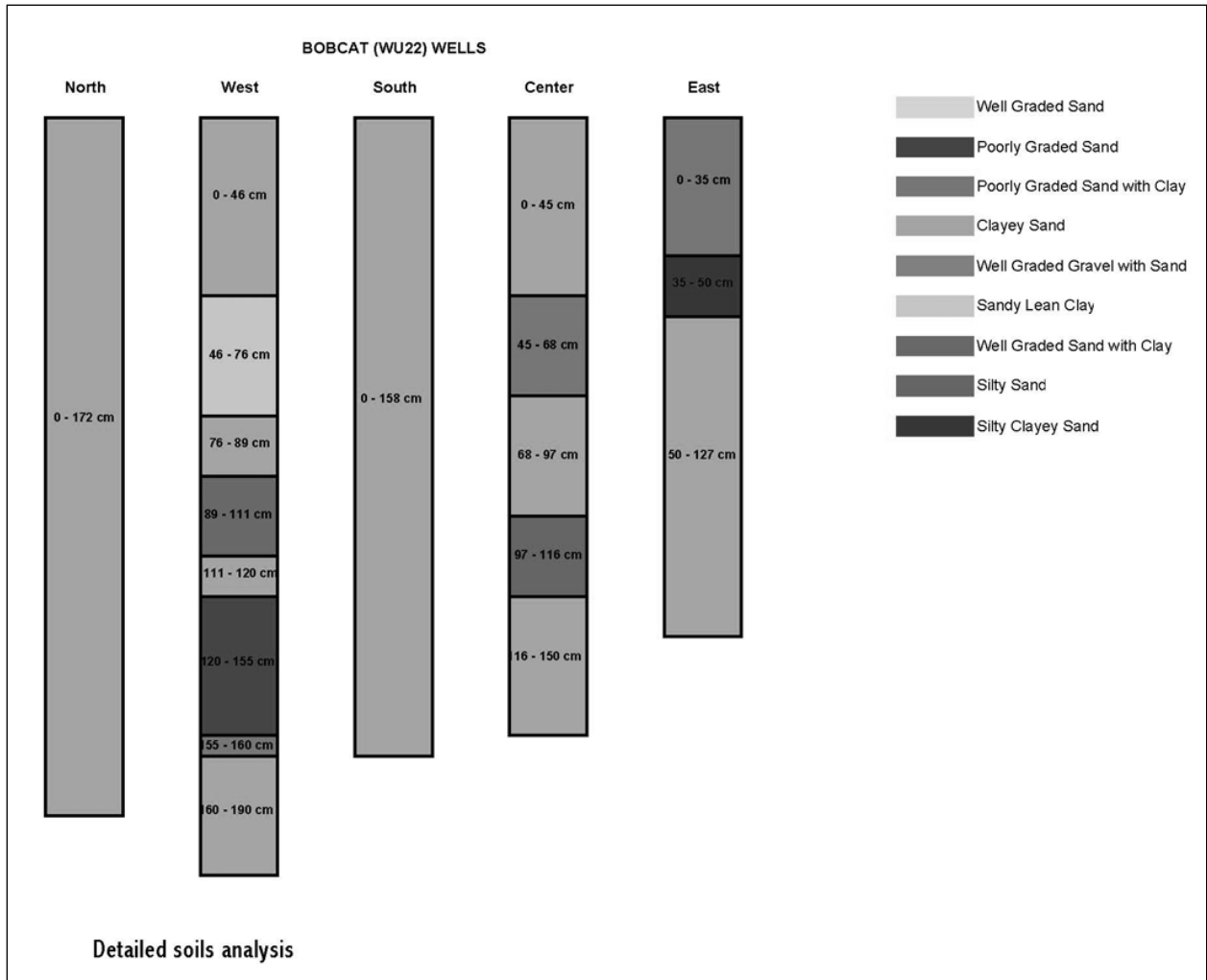

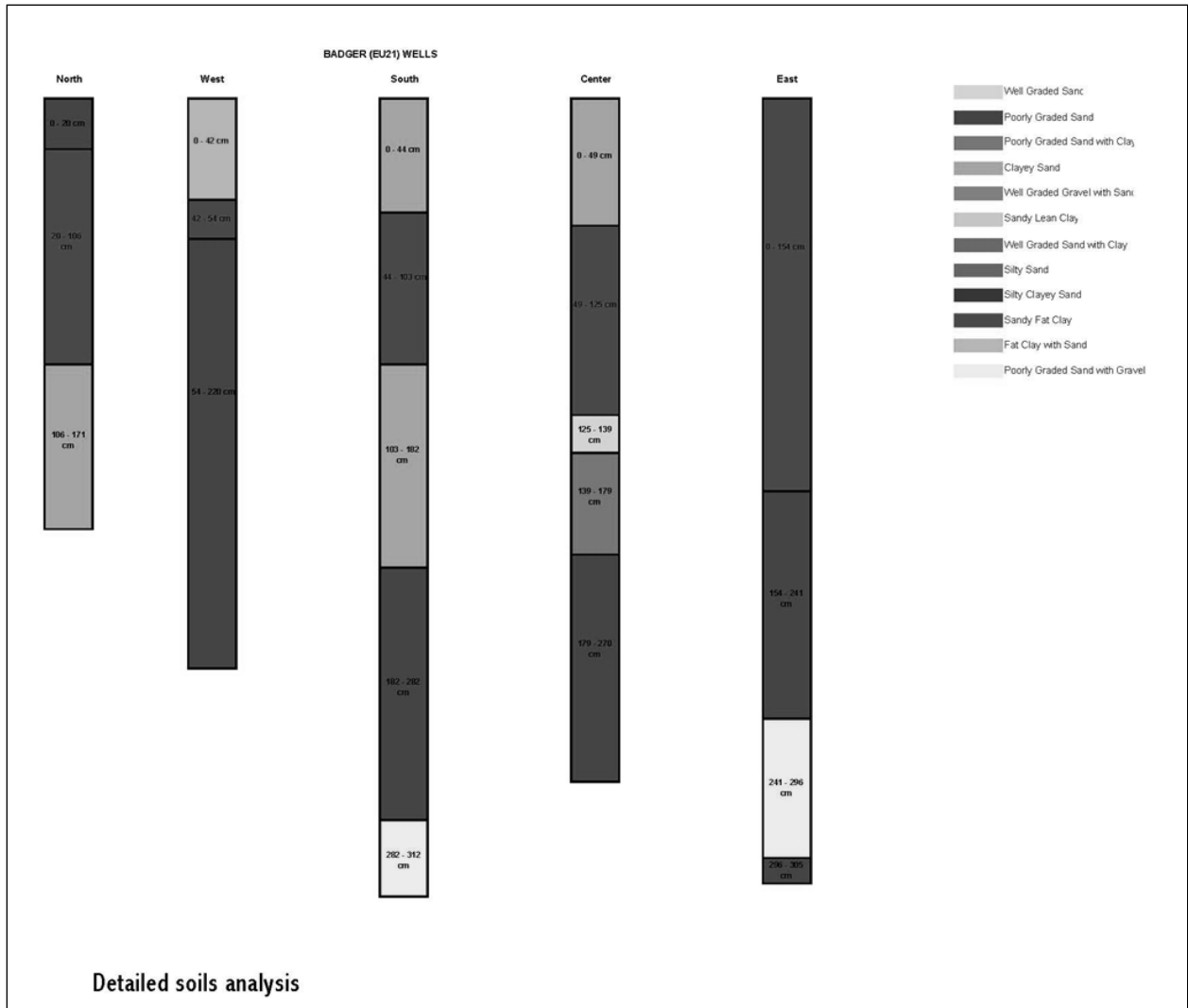

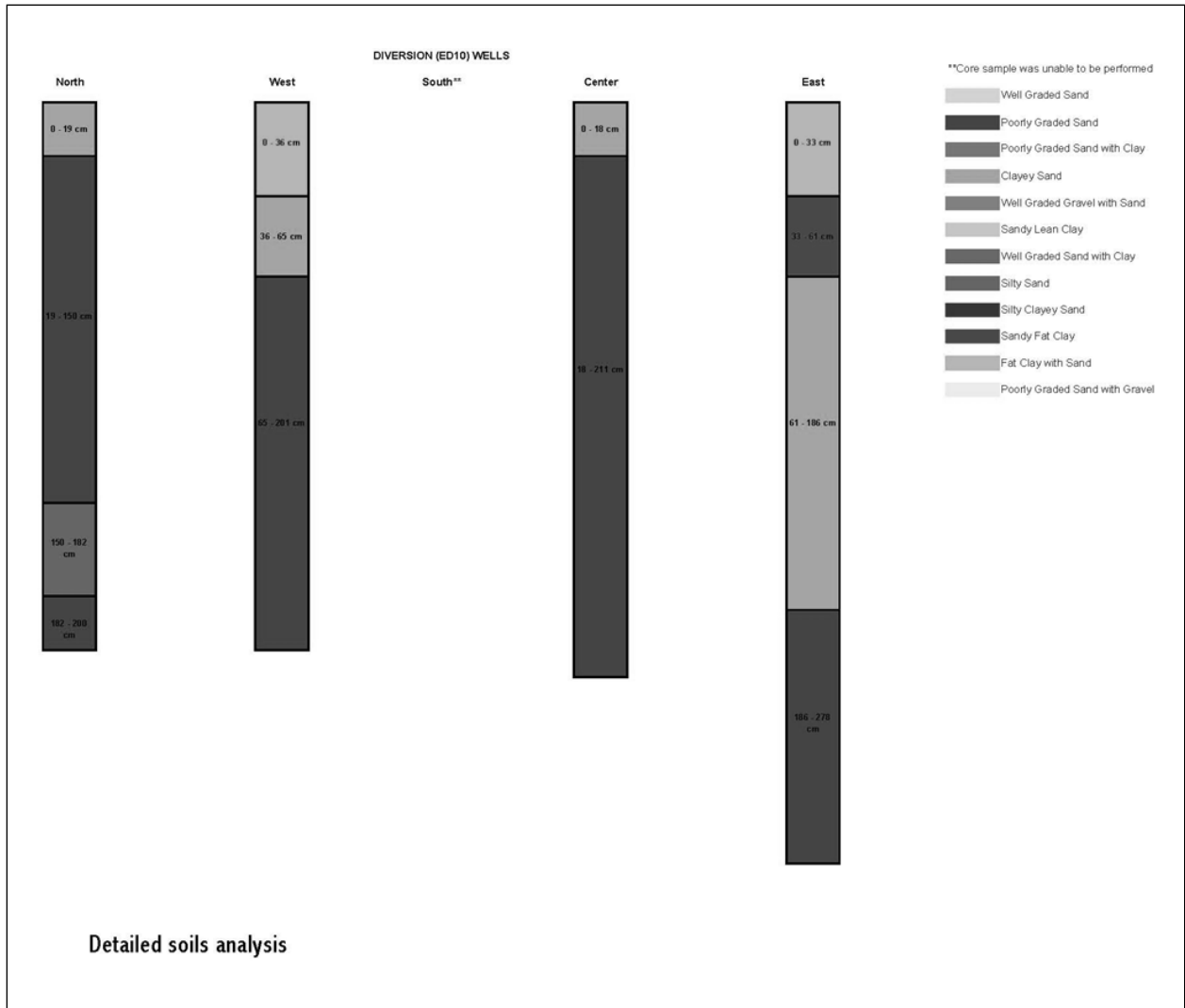

Appendix D: Minnow (WD12) Core Data Sheets



UNIVERSITY OF NEW MEXICO
DEPARTMENT OF CIVIL ENGINEERING

SOIL BORING LOG INFORMATION

PAGE 1 of 1

The University of New Mexico

Project Name Urban Flood Demonstration Program		Boring Classification ID WCN		Date of Drilling 1-Aug-06		Corresponding Well ID Minnow (WD12) North		
Boring Drilled By I. Pedro & C. LeJeune		Canopy Rain Gage 1.55"	Open Rain Gage 2.25"	Weather Cloudy & Rain				
Boring Location 3 Feet SW of Well		# of Soil Bags Collected 12	Water Table Depth 49.5"	Final Depth 55"	Well Exposure Depth 50"	Temperature N/A		
SAMPLE		DESCRIPTION (Visual-Manual Method)						COMMENTS
DEPTH (ft)	NUMBER	MOISTURE	COLOR	DRY STRENGTH	DILATANCY	TOUGHNESS	PLASTICITY	
0	0	VM	DBm					Organic material present (twigs, leaves and other organic matter)
1	1	VM	DBm		S	M	H	Organic material present
7	2	VM	Bm		S	M	M	Encountered roots @ 7"
9.5	3	VM	Bm		S	M	M	Encountered massive roots & organic material
12	4	VM	Bm		S	L	M	↓
17.5	5	VM	LBm		S	L	N	
21	6	VM	LBm		S	L	N	↓
27.5	7	VM	LBm		S	L	N	
33	8	VM	LBm		S	L	N	
39	9	VM	LBm		S	L	N	
45.5	10	VM	Bm		R	L	N	Soil saturated
51.5	11	VM	Bm		R	L	N	Water table reached @ 49.5"
55	12	W	Bm					Too saturated for VMM
								**Due to rain Dry Strength samples were ruined.
								**Rained night before and during coring.
I hereby certify that the information of this form is true and correct to the best of my knowledge								
Signature		Print Name			Date			
		Isarah Pedro / Christian Lejeune			1-Aug-06			

Detailed soils analysis



The University of New Mexico

UNIVERSITY OF NEW MEXICO
DEPARTMENT OF CIVIL ENGINEERING

WATER CONTENT DETERMINATION

Urban Flood Demonstration Project
Project

I. Pedro
Tested By

November 1, 2006
Date of Testing

November 2, 2006
Date of Dry Weighing

W/CN (Minnow N)
Boring Identification

CONTAINER NO. (PAN)	7	8	9	10	11	12	
FIELD TEXTURE	OM	Brown Sand	L.Brown Sand	L.Brown Sand	Brown Sand	Brown Sand	
BORING BAG NO.	1	2	5	9	10	12	
DEPTH (in)	0 - 1	1 - 7	12 - 17.5	33 - 39	39 - 45.5	51.5 - 55	
MASS OF CUP + WET SOIL (g)	192.2	506.7	684.7	1001.1	939.8	1076.4	
MASS OF CUP + DRY SOIL (g)	177.8	426.4	670.0	855.6	788.5	885.6	
MASS OF CUP (g)	137.8	138.0	139.4	139.4	137.6	137.2	
MASS OF DRY SOIL, Ms (g)	40.0	288.4	530.6	716.2	650.9	748.4	
MASS OF WATER, Mw (g)	14.4	80.3	14.7	145.5	151.3	190.8	
WATER CONTENT, w (%)	36.0%	27.8%	2.8%	20.3%	23.2%	25.5%	

CONTAINER NO. (PAN)							
FIELD TEXTURE							
BORING BAG NO.							
DEPTH (in)							
MASS OF CUP + WET SOIL (g)							
MASS OF CUP + DRY SOIL (g)							
MASS OF CUP (g)							
MASS OF DRY SOIL, Ms (g)							
MASS OF WATER, Mw (g)							
WATER CONTENT, w (%)							

$$w = \frac{M_w}{M_s} (100) \%$$

Detailed soils analysis



The University of New Mexico

UNIVERSITY OF NEW MEXICO
DEPARTMENT OF CIVIL ENGINEERING

GRAIN SIZE ANALYSIS

Urban Flood Demonstration Project
Project

WCN (Minnow N)
Boring Identification

I. Pedro
Tested By

7 1 1
Pan No. Soil Bag No. Sieve Set

November 2, 2006
Date of Testing

OM Material
Field Description of Soil

40
Mass of Dry Sample (g), M_d

0 - 1
Depth of Sample (h)

Sieve No.	Diameter (mm)	Mass of Sieve (g)	Mass retained (sieve + soil) (g)	% Retained	% Passing
4	4.75	503.3	503.3	0%	100%
10	2	464.4	469.1	12%	88%
20	0.85	412.9	429.8	42%	46%
40	0.425	369.8	377.8	20%	26%
60	0.25	353.9	358.7	12%	14%
140	0.106	342.0	346.1	10%	4%
200	0.075	327.9	328.5	2%	2%
Pan		364.2	365.7	2%	

% Passing = 100 - % Retained

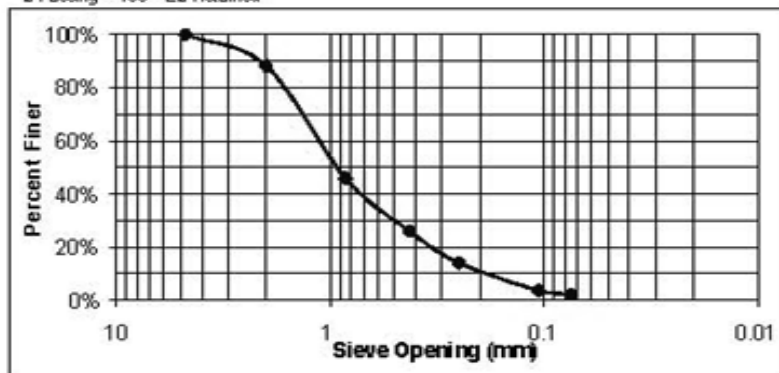

Detailed soils analysis



UNIVERSITY OF NEW MEXICO
DEPARTMENT OF CIVIL ENGINEERING

GRAIN SIZE ANALYSIS

Urban Flood Demonstration Project
Project

WCN (Minnow N)
Boring Identification

I. Pedro
Tested By

8 2 2
Pan No. Soil Bag No. Sieve Set

November 2, 2006
Date of Testing

Brown Sand
Field Description of Soil

288.4
Mass of Dry Sample (g), M

7-Jan
Depth of Sample (m)

Sieve No.	Diameter (mm)	Mass of Sieve (g)	Mass retained (sieve + soil) (g)	% Retained	% Passing
4	4.75	515.9	520.0	1%	99%
10	2	490.9	592.1	35%	63%
20	0.85	412.2	497.8	30%	34%
40	0.425	381.7	418.5	13%	21%
60	0.25	366.5	390.6	8%	13%
140	0.106	342.4	365.5	8%	5%
200	0.075	338.8	342.6	1%	3%
Pan		372.1	383.2	3%	

% Passing = 100 - % Retained

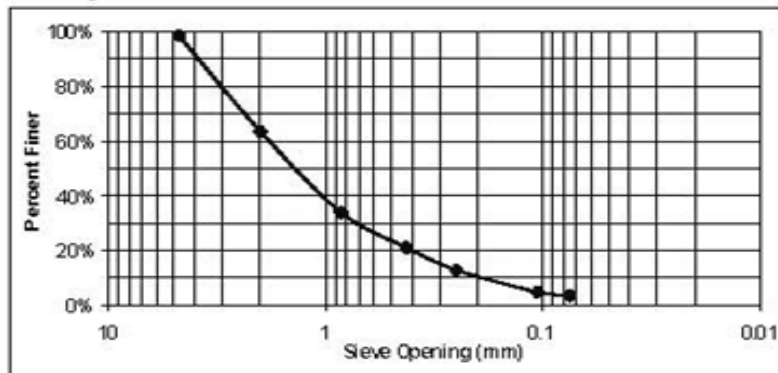

Detailed soils analysis



UNIVERSITY OF NEW MEXICO
DEPARTMENT OF CIVIL ENGINEERING

GRAIN SIZE ANALYSIS

Urban Flood Demonstration Project
Project

WCN (Minnow N)
Boring Identification

I. Pedro
Tested By

9 5 1
Pan No. Soil Bag No. Sieve Set

November 2, 2006
Date of Testing

Light Brown Sand
Field Description of Soil

530.6
Mass of Dry Sample (g), M

12" - 17.5"
Depth of Sample

Sieve No.	Diameter (mm)	Mass of Sieve (g)	Mass retained (sieve + soil) (g)	% Retained	% Passing
4	4.75	503.3	506.6	1%	99%
10	2	464.4	474.7	2%	97%
20	0.85	412.9	423.3	2%	95%
40	0.425	369.8	405.0	7%	89%
60	0.25	353.9	561.5	39%	50%
140	0.106	342.0	534.6	36%	13%
200	0.075	327.9	366.5	7%	6%
Pan		364.2	397.0	6%	

% Passing = 100 - % Retained

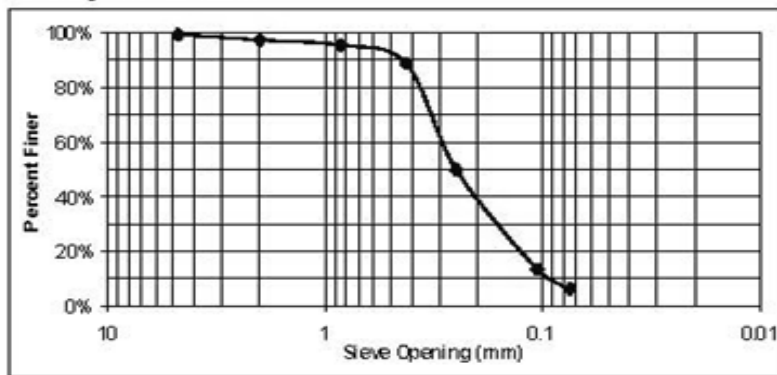

Detailed soils analysis



UNIVERSITY OF NEW MEXICO
DEPARTMENT OF CIVIL ENGINEERING

GRAIN SIZE ANALYSIS

Urban Flood Demonstration Project
Project

WCN (Minnow N)
Boring Identification

I. Pedro
Tested By

10 9 2
Pan No. Soil Bag No. Sieve Set

November 2, 2006
Date of Testing

Light Brown Sand
Field Description of Soil

716.2
Mass of Dry Sample (g), M

33" - 39"
Depth of Sample

Sieve No.	Diameter (mm)	Mass of Sieve (g)	Mass retained (sieve + soil) (g)	% Retained	% Passing
4	4.75	515.9	516.5	0%	100%
10	2	490.9	492.8	0%	100%
20	0.85	412.2	414.8	0%	99%
40	0.425	381.7	394.2	2%	98%
60	0.25	366.5	522.3	22%	76%
140	0.106	342.4	765.9	59%	17%
200	0.075	338.8	417.7	11%	6%
Pan		372.1	413.9	6%	

% Passing = 100 - % Retained

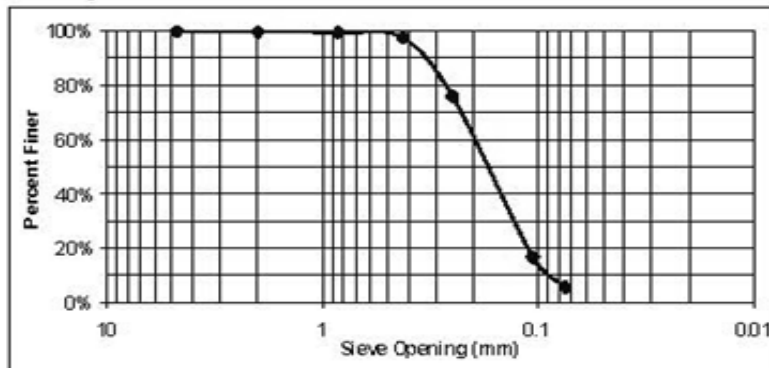

Detailed soils analysis



UNIVERSITY OF NEW MEXICO
DEPARTMENT OF CIVIL ENGINEERING

GRAIN SIZE ANALYSIS

Urban Flood Demonstration Project
Project

WCN (Minnow N)
Boring Identification

I. Pedro
Tested By

11 10 1
Pan No. Soil Bag No. Sieve Set

November 2, 2006
Date of Testing

Brown Sand
Field Description of Soil

650.9
Mass of Dry Sample (g), M_s

39" - 45.5"
Depth of Sample

Sieve No.	Diameter (mm)	Mass of Sieve (g)	Mass retained (sieve + soil) (g)	% Retained	% Passing
4	4.75	503.3	503.3	0%	100%
10	2	464.4	465.3	0%	100%
20	0.85	412.9	414.7	0%	100%
40	0.425	369.8	408.9	6%	94%
60	0.25	353.9	701.6	53%	40%
140	0.106	342.0	568.7	35%	5%
200	0.075	327.9	351.2	4%	2%
Pan		364.2	377.1	2%	

% Passing = 100 - % Retained

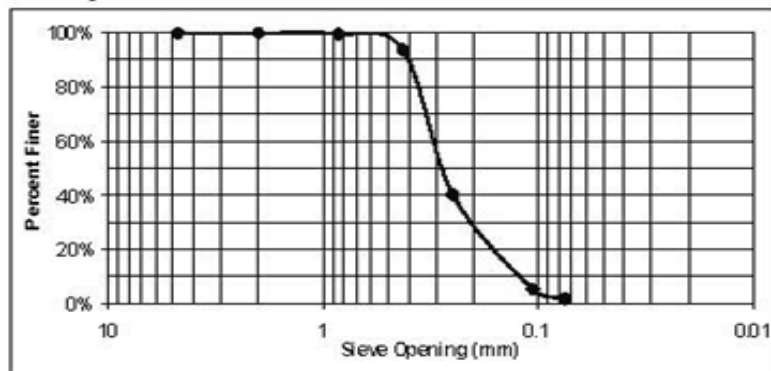

Detailed soils analysis



The University of New Mexico

UNIVERSITY OF NEW MEXICO
DEPARTMENT OF CIVIL ENGINEERING

GRAIN SIZE ANALYSIS

Urban Flood Demonstration Project
Projec

WCN (Minnow N)
Boring Identification

I. Pedro
Tested By

12 12 2
Pan No. Soil Bag No. Sieve Set

November 2, 2006
Date of Testing

Brown Sand
Field Description of Soil

748.4
Mass of Dry Sample (g), M

51.5' - 58'
Depth of Sample

Sieve No.	Diameter (mm)	Mass of Sieve (g)	Mass retained (sieve + soil) (g)	% Retained	% Passing
4	4.75	515.9	516.3	0%	100%
10	2	490.9	491.8	0%	100%
20	0.85	412.2	420.8	1%	99%
40	0.425	381.7	506.9	17%	82%
60	0.25	366.5	726.9	48%	34%
140	0.106	342.4	564.5	30%	4%
200	0.075	338.8	358.2	3%	2%
Pan		372.1	385.5	2%	

% Passing = 100 - % Retained

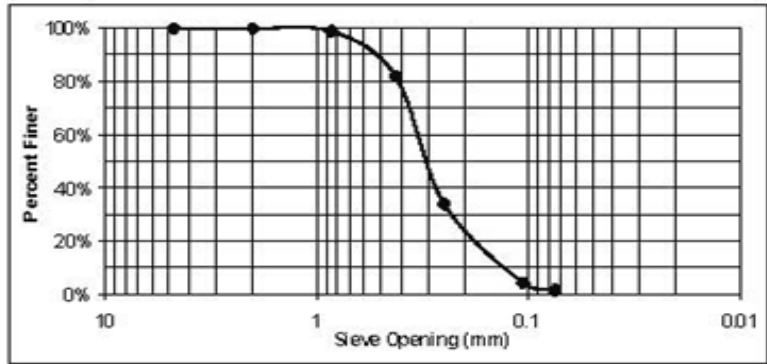

Detailed soils analysis



UNIVERSITY OF NEW MEXICO
DEPARTMENT OF CIVIL ENGINEERING

SOIL BORING LOG INFORMATION

PAGE 1 of 2

The University of New Mexico

Project Name Urban Flood Demonstration Project		Boring Classification ID WCW		Date of Drilling 25-Jul-06		Corresponding Well ID Minnow (WD12) West		
Boring Drilled By I. Pedro & C. LeJeune		Canopy Rain Gage 0.22"	Open Rain Gage 0.5"	Weather Sunny				
Boring Location 3 Feet SW of Well		# of Soil Bags Collected 26	Water Table Depth 78"	Final Depth 91"	Well Elevation N/A	Temperature N/A		
DEPTH (ft)	SAMPLE NUMBER	DESCRIPTION (Visual-Manual Method)						COMMENTS
		MOISTURE	COLOR	DRY STRENGTH	DILATANCY	TOUGHNESS	PLASTICITY	
0	0		DBm					Surface covered with leaves & logs. Dark Brown organic appearance.
2	1	M	DBm	H	S	H	H	Organic material present.
5.5	2	M	Bm	H	S	H	H	Brown Sand appearance.
8	3	M	Bm	H	S	H	H	Same color & consistency as above
9.5	4	M	Bm	H	S	H	H	↓
12	5	M	LBm	H	S	H	H	Material turned light brown. Contact with tree roots
16.5	6	VM	LBm	M	S	H	H	
22	7	VM	Bm	M	S	H	H	
23.5	8	VM	Bm	M	S	M	M	
26	9	VM	LBm	L	S	L	L	
31.5	10	VM	Bm	M	S	L	L	
36	11	VM	LBm	L	S	L	L	
40	12	VM	LBm	M	S	L	M	
46	13	VM	LBm	L	S	L	L	
51	14	M	LBm	L	S	L	L	
56	15	M	LBm	L	S	L	L	
58	16	M	LBm	L	S	L	L	↓
61	17	VM	DBm	M	N	L	L	Material came out in clumps and has some organic material present
I hereby certify that the information of this form is true and correct to the best of my knowledge								
Signature			Print Name			Date		
			Isaiah Pedro / Christian LeJeune			25-Jul-06		

Detailed soils analysis



UNIVERSITY OF NEW MEXICO
DEPARTMENT OF CIVIL ENGINEERING

WATER CONTENT DETERMINATION

The University of New Mexico

Urban Flood Demonstration Project
Project

I. Pedro
Tested By

October 23, 2006
Date of Testing

October 24, 2006
Date of Dry Weighing

WCW (Minnow W)
Boring Identification

CONTAINER NO. (PAN)	1	2	3	4	5	6	7
FIELD TEXTURE	Brown Sand	L. Brown Sand	L. Brown Sand	L. Brown Sand	Sand w/Clay	Sand w/Clay	Sand w/Clay
BORING BAG NO.	3	5	11	16	17	20	21
DEPTH (ft)	5 1/4" - 8"	9 1/2" - 12"	31 1/2" - 36"	56" - 58"	58" - 61"	66" - 68"	68" - 71"
MASS OF CUP + WET SOIL (g)	157.1	164.4	157.1	154.8	164.3	204.5	255.6
MASS OF CUP + DRY SOIL (g)	141.7	157.7	142.3	138.8	132.1	155.3	193.6
MASS OF CUP (g)	32.4	32.1	32.4	32.6	32.2	32.5	32.4
MASS OF DRY SOIL, Ms (g)	109.3	125.6	109.9	106.2	99.9	122.8	161.2
MASS OF WATER, Mw (g)	15.4	6.7	14.8	16.0	32.2	49.2	62.0
WATER CONTENT, w (%)	14.1%	5.3%	13.5%	15.1%	32.2%	40.1%	38.5%

CONTAINER NO. (PAN)	8	9					
FIELD TEXTURE	Gray Sand	Gray Sand					
BORING BAG NO.	23	26					
DEPTH (ft)	76" - 80"	89" - 91"					
MASS OF CUP + WET SOIL (g)	278.3	257.9					
MASS OF CUP + DRY SOIL (g)	229.4	213.9					
MASS OF CUP (g)	32.2	32.4					
MASS OF DRY SOIL, Ms (g)	197.2	181.5					
MASS OF WATER, Mw (g)	48.9	44.0					
WATER CONTENT, w (%)	24.8%	24.2%					

$$w = \frac{M_w}{M_s} (100) \%$$

Detailed soils analysis



UNIVERSITY OF NEW MEXICO
DEPARTMENT OF CIVIL ENGINEERING

GRAIN SIZE ANALYSIS

Urban Flood Demonstration Project
Project

WCW (Minnow W)
Boring Identification

C. LeJeune & I. Pedro
Tested By

1 3 1
Pan No. Soil Bag No. Sieve Set

October 25, 2006
Date of Testing

Brown Sand
Field Description of Soil

240.3
Mass of Dry Sample (g), M_s

5.25 - 8
Depth of Sample (in)

Sieve No.	Diameter (mm)	Mass of Sieve (g)	Mass retained (sieve + soil) (g)	% Retained	% Passing
4	4.75	503.3	503.3	0%	100%
10	2	464.4	496.7	13%	87%
20	0.85	412.9	433.6	9%	78%
40	0.425	369.8	379.5	4%	74%
60	0.25	353.9	363.9	4%	70%
140	0.106	342.0	454.0	47%	23%
200	0.075	327.9	372.5	19%	5%
Pan		364.2	375.3	5%	

% Passing = 100 - % Retained

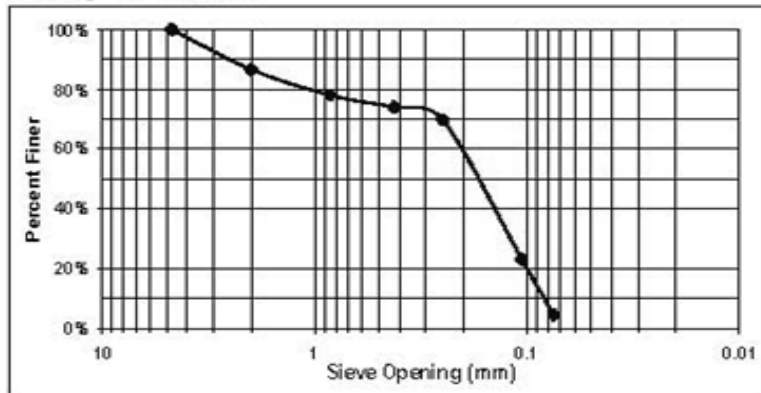

Detailed soils analysis



The University of New Mexico

UNIVERSITY OF NEW MEXICO
DEPARTMENT OF CIVIL ENGINEERING

GRAIN SIZE ANALYSIS

Urban Flood Demonstration Project
Project

WCW (Minnow W)
Boring Identification

C. LaJeune & I. Pedro
Tested By

2 5 2
Pan No. Soil Bag No. Sieve Set

October 25, 2006
Date of Testing

Light Brown Sand
Field Description of Soil

225.9
Mass of Dry Sample (g), M

9.5 - 12
Depth of Sample (ft)

Sieve No.	Diameter (mm)	Mass of Sieve (g)	Mass retained (sieve + soil) (g)	% Retained	% Passing
4	4.75	515.9	517.3	1%	99%
10	2	490.9	495.1	2%	98%
20	0.85	412.2	419.1	3%	94%
40	0.425	381.7	385.9	2%	93%
60	0.25	366.5	370.8	2%	91%
140	0.106	342.4	447.5	47%	44%
200	0.075	338.8	404.4	29%	15%
Pan		372.1	407.0	15%	

% Passing = 100 - % Retained

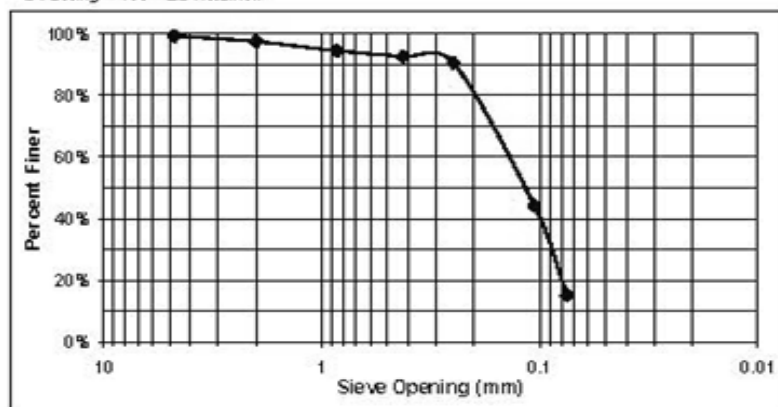

Detailed soils analysis



UNIVERSITY OF NEW MEXICO
DEPARTMENT OF CIVIL ENGINEERING

GRAIN SIZE ANALYSIS

Urban Flood Demonstration Project
Project

WCW (Minnow W)
Boring Identification

C. LeJeune & I. Pedro
Tested By

3 11 1
Pan No. Soil Bag No. Sieve Set

October 25, 2006
Date of Testing

Light Brown Sand
Field Description of Soil

350.1
Mass of Dry Sample (g), M

31.5 - 36
Depth of Sample (h)

Sieve No.	Diameter (mm)	Mass of Sieve (g)	Mass retained (sieve + soil) (g)	% Retained	% Passing
4	4.75	503.3	503.7	0%	100%
10	2	464.4	470.2	2%	98%
20	0.85	412.9	419.9	2%	96%
40	0.425	369.8	376.2	2%	94%
60	0.25	353.9	359.8	2%	93%
140	0.106	342.0	415.3	21%	72%
200	0.075	327.9	435.1	31%	41%
Pan		364.2	508.7	41%	

% Passing = 100 - % Retained

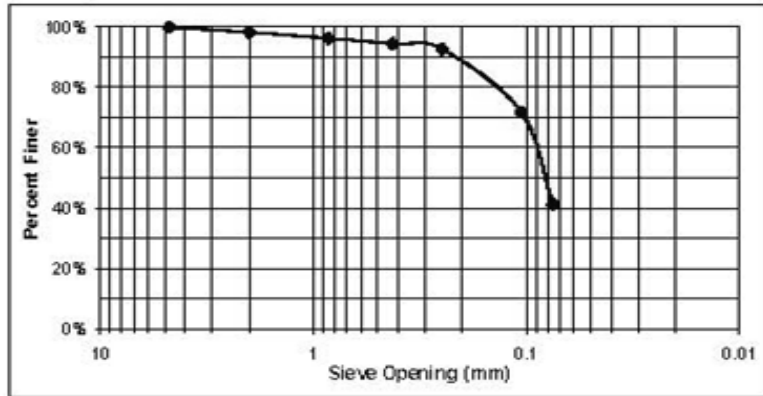

Detailed soils analysis



The University of New Mexico

UNIVERSITY OF NEW MEXICO
DEPARTMENT OF CIVIL ENGINEERING

GRAIN SIZE ANALYSIS

Urban Flood Demonstration Project
Project

WCW (Minnov W)
Boring Identification

C. LeJeune & I. Pedro
Tested By

4 16 2
Pan No. Soil Bag No. Sieve Set

October 25, 2006
Date of Testing

Light Brown Sand
Field Description of Soil

62.4
Mass of Dry Sample (g), M

56 - 58
Depth of Sample (ft)

Sieve No.	Diameter (mm)	Mass of Sieve (g)	Mass retained (sieve + soil) (g)	% Retained	% Passing
4	4.75	515.9	516	0%	100%
10	2	490.9	500.7	16%	84%
20	0.85	412.2	422.8	17%	67%
40	0.425	381.7	386.7	8%	59%
60	0.25	366.5	369.9	5%	54%
140	0.106	342.4	353.5	18%	36%
200	0.075	338.8	351.8	21%	15%
Pan		372.1	382.2	15%	

% Passing = 100 - % Retained

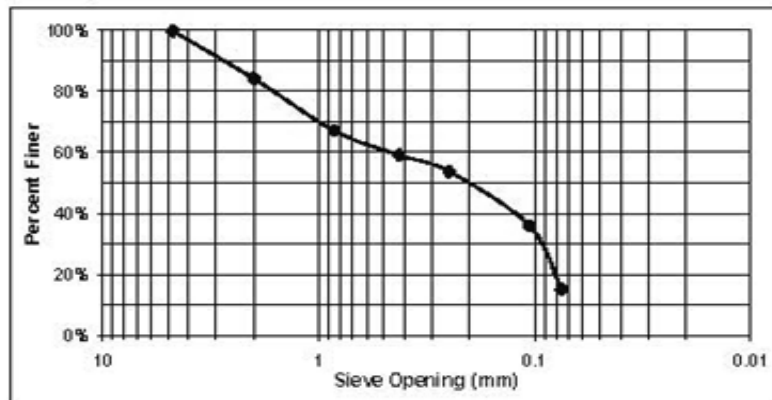

Detailed soils analysis



UNIVERSITY OF NEW MEXICO
DEPARTMENT OF CIVIL ENGINEERING

GRAIN SIZE ANALYSIS

Urban Flood Demonstration Project
Project

WCW (Minnow W)
Boring Identification

C. LeJeune & I. Pedro
Tested By

5 17 1
Pan No. Soil Bag No. Sieve Set

October 25, 2006
Date of Testing

Sand w/Clay
Field Description of Soil

293.9
Mass of Dry Sample (g), M_s

58 - 61
Depth of Sample (ft)

Sieve No.	Diameter (mm)	Mass of Sieve (g)	Mass retained (sieve + soil) (g)	% Retained	% Passing
4	4.75	503.3	653.3	51%	49%
10	2	464.4	549.7	29%	20%
20	0.85	412.9	440.2	9%	11%
40	0.425	369.8	382.4	4%	6%
60	0.25	353.9	359.7	2%	4%
140	0.106	342.0	349.3	2%	2%
200	0.075	327.9	330.5	1%	1%
Pan		364.2	368.8	1%	

% Passing = 100 - % Retained

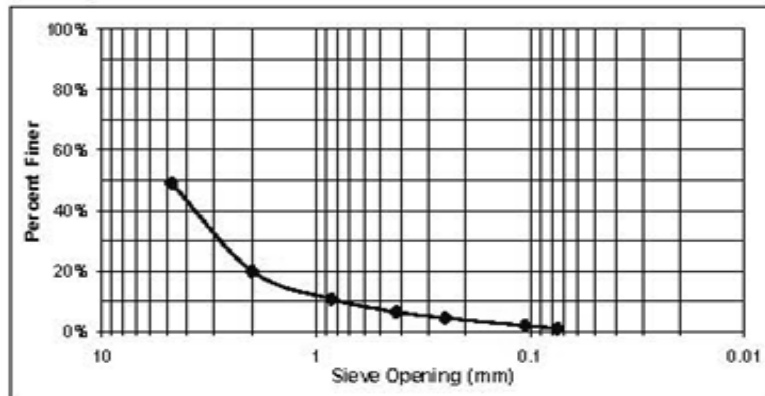

Detailed soils analysis



UNIVERSITY OF NEW MEXICO
DEPARTMENT OF CIVIL ENGINEERING

GRAIN SIZE ANALYSIS

Urban Flood Demonstration Project
Project

WCW (Minnow W)
Boring Identification

C. LeJeune & I. Pedro
Tested By

6 20 1
Pan No. Soil Bag No. Sieve Set

October 25, 2006
Date of Testing

Sand w/Clay
Field Description of Soil

46.4
Mass of Dry Sample (g), M

66 - 68
Depth of Sample (in)

Sieve No.	Diameter (mm)	Mass of Sieve (g)	Mass retained (sieve + soil) (g)	% Retained	% Passing
4	4.75	503.3	504.1	2%	98%
10	2	464.4	473.8	20%	78%
20	0.85	412.9	418.6	12%	66%
40	0.425	369.8	375.4	12%	54%
60	0.25	353.9	357.4	8%	46%
140	0.106	342.0	350.5	18%	28%
200	0.075	327.9	337.8	21%	6%
Pan		364.2	367.5	6%	

% Passing = 100 - % Retained

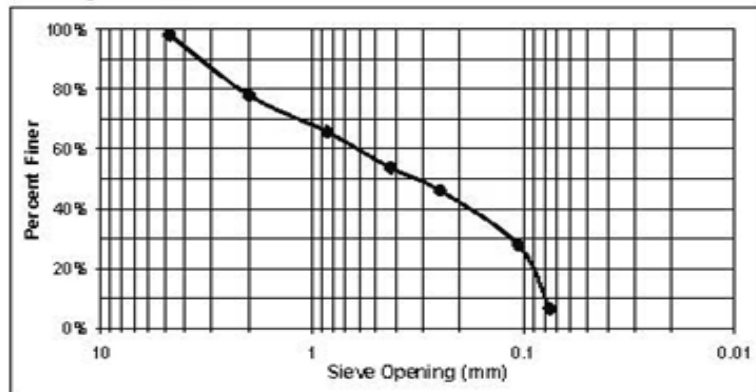

Detailed soils analysis



UNIVERSITY OF NEW MEXICO
DEPARTMENT OF CIVIL ENGINEERING

GRAIN SIZE ANALYSIS

Urban Flood Demonstration Project
Project

WCW (Minnow W)
Boring Identification

C. LeJeune & I. Pedro
Tested By

7 21 1
Pan No. Soil Bag No. Sieve Set

October 25, 2006
Date of Testing

Sand w/Clay
Field Description of Soil

162.8
Mass of Dry Sample (g), M

68 - 71
Depth of Sample (m)

Sieve No.	Diameter (mm)	Mass of Sieve (g)	Mass retained (sieve + soil) (g)	% Retained	% Passing
4	4.75	503.3	534.1	19%	81%
10	2	464.4	508.3	27%	54%
20	0.85	412.9	429.6	10%	44%
40	0.425	369.8	378.4	5%	39%
60	0.25	353.9	359.6	4%	35%
140	0.106	342.0	365.9	15%	20%
200	0.075	327.9	353.4	16%	5%
Pan		364.2	373.3	5%	

% Passing = 100 - % Retained

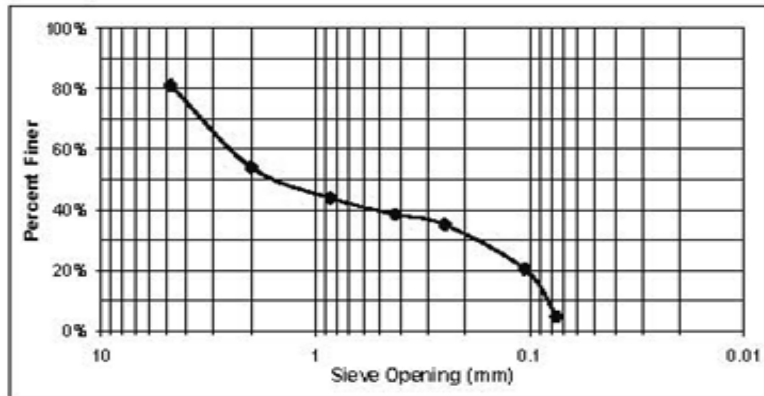

Detailed soils analysis



The University of New Mexico

UNIVERSITY OF NEW MEXICO
DEPARTMENT OF CIVIL ENGINEERING

GRAIN SIZE ANALYSIS

Urban Flood Demonstration Project
Project

WCW (Minnow W)
Boring Identification

C. LeJeune & I. Pedro
Tested By

8 23 2
Pan No. Soil Bag No. Sieve Set

October 25, 2006
Date of Testing

Gray Sand
Field Description of Soil

511.9
Mass of Dry Sample (g), M

76 - 80
Depth of Sample (ft)

Sieve No.	Diameter (mm)	Mass of Sieve (g)	Mass retained (sieve + soil) (g)	% Retained	% Passing
4	4.75	515.9	516.3	0%	100%
10	2	490.9	493.7	1%	99%
20	0.85	412.2	415.4	1%	99%
40	0.425	381.7	394.0	2%	96%
60	0.25	366.5	424.5	11%	85%
140	0.106	342.4	690.8	68%	17%
200	0.075	338.8	409.1	14%	3%
Pan		372.1	389.6	3%	

% Passing = 100 - % Retained

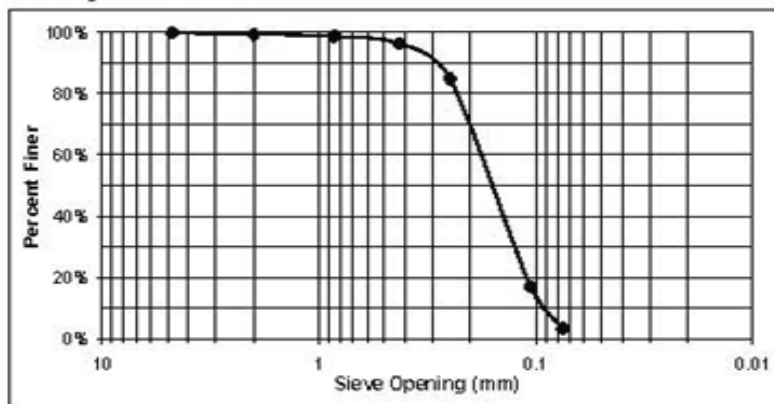

Detailed soils analysis



UNIVERSITY OF NEW MEXICO
DEPARTMENT OF CIVIL ENGINEERING

GRAIN SIZE ANALYSIS

The University of New Mexico

Urban Flood Demonstration Project
Project

WCW (Minnow W)
Boring Identification

C. LaJeune & I. Pedro
Tested By

9 26 2
Pan No. Soil Bag No. Sieve Set

October 25, 2006
Date of Testing

Gray Sand
Field Description of Soil

331.3
Mass of Dry Sample (g), M

89 - 91
Depth of Sample (ft)

Sieve No.	Diameter (mm)	Mass of Sieve (g)	Mass retained (sieve + soil) (g)	% Retained	% Passing
4	4.75	515.9	516.2	0%	100%
10	2	490.9	491.8	0%	100%
20	0.85	412.2	414.0	1%	99%
40	0.425	381.7	390.8	3%	96%
60	0.25	366.5	413.4	14%	82%
140	0.106	342.4	566.5	68%	15%
200	0.075	338.8	380.3	13%	2%
Pan		372.1	379.7	2%	

% Passing = 100 - % Retained

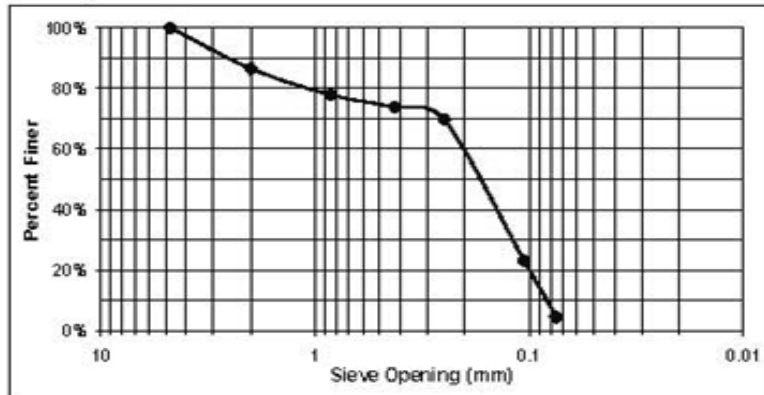

Detailed soils analysis



The University of New Mexico

UNIVERSITY OF NEW MEXICO
DEPARTMENT OF CIVIL ENGINEERING

SOIL BORING LOG INFORMATION

PAGE 1 of 1

Project Name Urban Flood Demonstration Project		Boring Classification ID WCS		Date of Drilling 2-Aug-06		Corresponding Well ID Minnow (WD12) South		
Boring Drilled By I. Pedro & C. LeJeune		Canopy Rain Gage 1.6"		Open Rain Gage 2.35"		Weather Sunny w/Clouds		
Boring Location 4 Feet SW of Well		# of Soil Bags Collected 15		Water Table Depth 50"		Final Depth 60"		
				Well Bottom Depth 50"		Temperatures N/A		
SAMPLE		DESCRIPTION (Visual-Manual Method)						COMMENTS
DEPTH (ft)	NUMBER	MOISTURE	COLOR	DRY STRENGTH	DILATANCY	TOUGHNESS	PLASTICITY	
0	0	M	DBm					Organic Material Present (twigs, leaves and seeds)
4	1	M	DBm					Organic Material present
6	2	M	Bm					↓
12	3	M	Bm					Fine Sand Appearance. Came into contact with roots
15	4	M	Bm					↓
16	5	M	LBm					↓
17	6	M	LBm					↓
21.5	7	M	LBm					Contact with roots. More Sandy appearance.
23	8	M	LBm					↓
28	9	M	Tan					↓
33.5	10	M	Tan					↓
39	11	M	Tan					↓
44	12	VM	Tan					↓
46	13	VM	Tan					Sand with Gravel appearance
53	14	W	Tan					Contact with water table @ 50"
60	15	W	Tan					↓
								**No Classification Test Performed
								**Rained Night Before
I hereby certify that the information of this form is true and correct to the best of my knowledge								
Signature				Print Name		Date		
				Isaiah Pedro / Christian LeJeune		2-Aug-06		

Detailed soils analysis



UNIVERSITY OF NEW MEXICO
DEPARTMENT OF CIVIL ENGINEERING

WATER CONTENT DETERMINATION

Urban Flood Demonstration Project
Project

I. Pedro
Tested By

November 6, 2006
Date of Testing

November 7, 2006
Date of Dry Weighing

WCS (Minnow S)
Boring Identification

CONTAINER NO. (PAN)	8	9	10	11	12	13	14
FIELD TEXTURE	OM	Sand w/Clay	L.Brown Sand	L.Brown Sand	L.Brown Sand	Sand w/Gravel	Sand w/Gravel
BORING BAG NO.	1	3	7	10	13	14	15
DEPTH (in)	0 - 4	6 - 12	17 - 21.5	28 - 33.5	44 - 46	46 - 53	53 - 60
MASS OF CUP + WET SOIL (g)	542.7	592.9	678.1	901.3	363.9	941.4	888.8
MASS OF CUP + DRY SOIL (g)	456.0	547.1	653.2	868.9	335.0	804.0	764.1
MASS OF CUP (g)	138.0	139.4	139.4	137.6	137.2	138.6	138.3
MASS OF DRY SOIL, Ms (g)	318.0	407.7	513.8	731.3	197.8	665.4	625.8
MASS OF WATER, Mw (g)	86.7	45.8	24.9	32.4	28.9	137.4	124.7
WATER CONTENT, w (%)	27.3%	11.2%	4.8%	4.4%	14.6%	20.6%	19.9%

CONTAINER NO. (PAN)							
FIELD TEXTURE							
BORING BAG NO.							
DEPTH (in)							
MASS OF CUP + WET SOIL (g)							
MASS OF CUP + DRY SOIL (g)							
MASS OF CUP (g)							
MASS OF DRY SOIL, Ms (g)							
MASS OF WATER, Mw (g)							
WATER CONTENT, w (%)							

$$w = \frac{M_w}{M_s} (100) \%$$

Detailed soils analysis



UNIVERSITY OF NEW MEXICO
DEPARTMENT OF CIVIL ENGINEERING

GRAIN SIZE ANALYSIS

The University of New Mexico

Urban Flood Demonstration Project
Project

WCS (Minnow S)
Boiling Identification

I. Pedro & C. LaJeune
Tested By

8 1 1
Pan No. Soil Bag No. Sieve Set

November 7, 2006
Date of Testing

OM Material
Field Description of Soil

318
Mass of Dry Sample (g), M_s

0 - 4
Depth of Sample (in)

Sieve No.	Diameter (mm)	Mass of Sieve (g)	Mass retained (sieve + soil) (g)	% Retained	% Passing
4	4.75	503.3	503.3	0%	100%
10	2	464.4	464.7	0%	100%
20	0.85	412.9	469.4	18%	82%
40	0.425	369.8	436.9	21%	61%
60	0.25	353.9	394.1	13%	48%
140	0.106	342.0	426.4	27%	22%
200	0.075	327.9	352.2	8%	14%
Pan		364.2	413.5	14%	

% Passing = 100 - % Retained

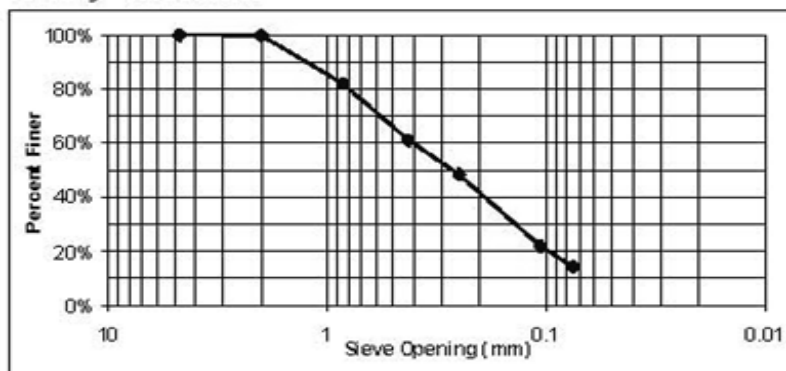

Detailed soils analysis



The University of New Mexico

UNIVERSITY OF NEW MEXICO
DEPARTMENT OF CIVIL ENGINEERING

GRAIN SIZE ANALYSIS

Urban Flood Demonstration Project
Project

WCS (Minnow S)
Boing Identification

I. Pedro & C. LaJeune
Tested By

9 Pan No. 3 Soil Bag No. 2 Sieve Set

November 7, 2006
Date of Testing

Sand with Clay
Field Description of Soil

407.7
Mass of Dry Sample (g), M_s

6 - 12
Depth of Sample (in)

Sieve No.	Diameter (mm)	Mass of Sieve (g)	Mass retained (sieve + soil) (g)	% Retained	% Passing
4	4.75	515.9	516.2	0%	100%
10	2	490.9	505.3	4%	96%
20	0.85	412.2	433.2	5%	91%
40	0.425	381.7	394.7	3%	88%
60	0.25	366.5	379.9	3%	85%
140	0.106	342.4	566.7	55%	30%
200	0.075	338.8	396.7	14%	16%
Pan		364.0	431.8	16%	

% Passing = 100 - Σ% Retained

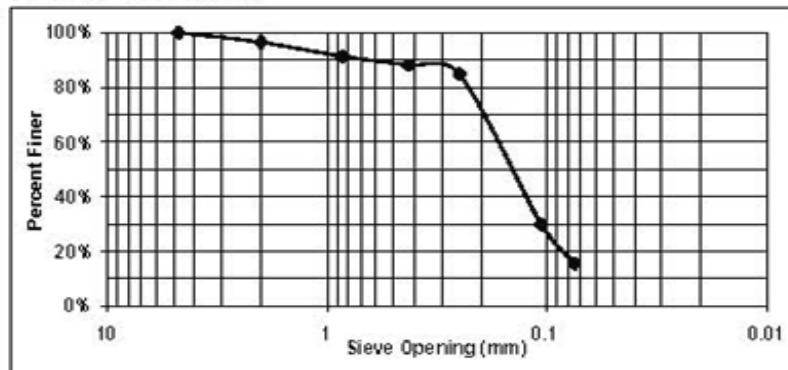

Detailed soils analysis



UNIVERSITY OF NEW MEXICO
DEPARTMENT OF CIVIL ENGINEERING

GRAIN SIZE ANALYSIS

The University of New Mexico

Urban Flood Demonstration Project

WCS (Minnow S)

Project

Boeing Identification

I. Pedro & C. LaJeune

10 7 1
Pan No. Soil Bag No. Sieve Set

Tested By

November 7, 2006

Light Brown Sand

Date of Testing

Field Description of Soil

513.8

17 - 21.5

Mass of Dry Sample (g), M_s

Depth of Sample (m)

Sieve No.	Diameter (mm)	Mass of Sieve (g)	Mass retained (sieve + soil) (g)	% Retained	% Passing
4	4.75	503.3	504.2	0%	100%
10	2	464.4	483.4	4%	96%
20	0.85	412.9	440.4	5%	91%
40	0.425	369.8	417.4	9%	82%
60	0.25	353.9	524.8	33%	48%
140	0.106	342.0	549.1	40%	8%
200	0.075	327.9	347.1	4%	4%
Pan		364.2	388.2	4%	

% Passing = 100 - Σ% Retained

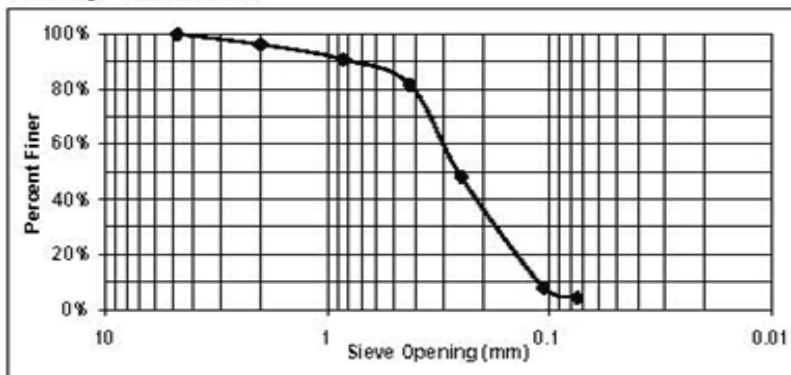

Detailed soils analysis



The University of New Mexico

UNIVERSITY OF NEW MEXICO
DEPARTMENT OF CIVIL ENGINEERING

GRAIN SIZE ANALYSIS

Urban Flood Demonstration Project
Project

WCS (Minnow S)
Boiling Identification

I. Pedro & C. LaJeune
Tested By

11 Pan No. 10 Soil Bag No. 2 Sieve Set

November 7, 2006
Date of Testing

Light Brown Sand
Field Description of Soil

731.1
Mass of Dry Sample (g), M_s

28 - 33.5
Depth of Sample (in)

Sieve No.	Diameter (mm)	Mass of Sieve (g)	Mass retained (sieve + soil) (g)	% Retained	% Passing
4	4.75	515.9	517.5	0%	100%
10	2	490.9	502.2	2%	98%
20	0.85	412.2	428.9	2%	96%
40	0.425	381.7	462.2	11%	85%
60	0.25	366.5	693.2	45%	40%
140	0.106	342.4	613.7	37%	3%
200	0.075	338.8	356.1	2%	1%
Pan		364.0	372.9	1%	

% Passing = 100 - Σ% Retained

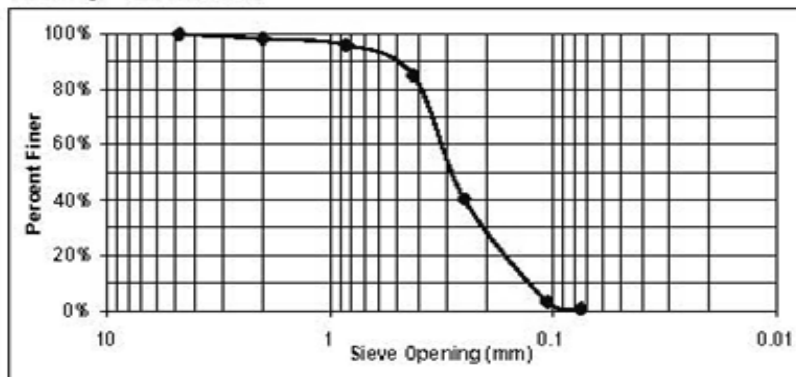

Detailed soils analysis



The University of New Mexico

UNIVERSITY OF NEW MEXICO
DEPARTMENT OF CIVIL ENGINEERING

GRAIN SIZE ANALYSIS

Urban Flood Demonstration Project
Project

WCS (Minnow S)
Boing Identification

I. Pedro & C. LaJeune
Tested By

12 13 1
Pan No. Soil Bag No. Sieve Set

November 7, 2006
Date of Testing

Light Brown Sand
Field Description of Soil

197.8
Mass of Dry Sample (g), M_s

44 - 46
Depth of Sample (in)

Sieve No.	Diameter (mm)	Mass of Sieve (g)	Mass retained (sieve + soil) (g)	% Retained	% Passing
4	4.75	503.3	506.2	1%	99%
10	2	464.4	471.7	4%	95%
20	0.85	412.9	429.9	9%	86%
40	0.425	369.8	444.1	38%	49%
60	0.25	353.9	424.9	36%	13%
140	0.106	342.0	369.5	13%	0%
200	0.075	327.9	329.3	0%	0%
Pan		364.2	365.0	0%	

% Passing = 100 - Σ% Retained

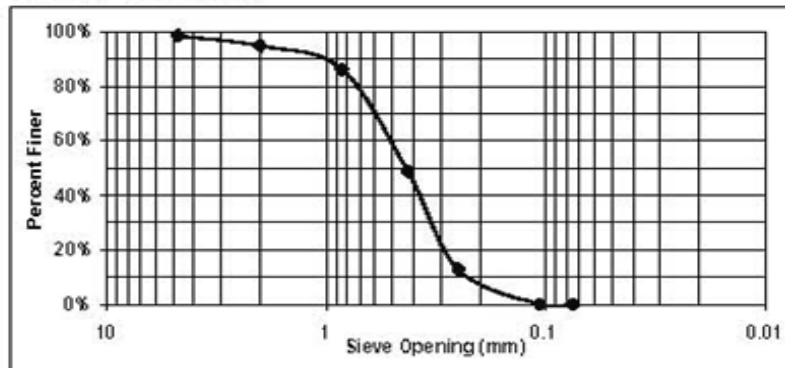

Detailed soils analysis



UNIVERSITY OF NEW MEXICO
DEPARTMENT OF CIVIL ENGINEERING

GRAIN SIZE ANALYSIS

The University of New Mexico

Urban Flood Demonstration Project
Project

WCS (Minnow S)
Boing Identification

L. Pedro & C. LaJeune
Tested By

13 14 2
Pan No. Soil Bag No. Sieve Set

November 7, 2006
Date of Testing

Sand with Gravel
Field Description of Soil

665.4
Mass of Dry Sample (g), M_s

46 - 53
Depth of Sample (in)

Sieve No.	Diameter (mm)	Mass of Sieve (g)	Mass retained (sieve + soil) (g)	% Retained	% Passing
4	4.75	515.9	522.6	1%	99%
10	2	490.9	502.1	2%	97%
20	0.85	412.2	443.5	5%	93%
40	0.425	381.7	598.0	33%	60%
60	0.25	366.5	657.7	44%	16%
140	0.106	342.4	442.6	15%	1%
200	0.075	338.8	345.0	1%	0%
Pan		364.0	368.2	0%	

% Passing = 100 - Σ% Retained

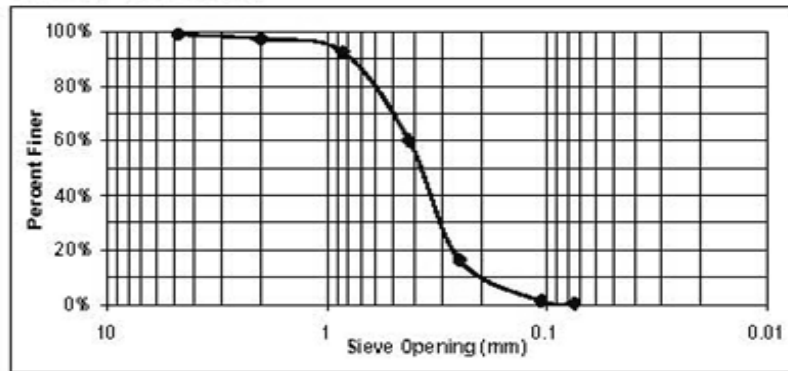

Detailed soils analysis



UNIVERSITY OF NEW MEXICO
DEPARTMENT OF CIVIL ENGINEERING

GRAIN SIZE ANALYSIS

The University of New Mexico

Urban Flood Demonstration Project
Project

WCS (Minnow S)
Boing Identification

I. Pedro & C. LaJeune
Tested By

14 15 1
Pan No. Soil Bag No. Sieve Set

November 7, 2006
Date of Testing

Sand with Gravel
Field Description of Soil

625.8
Mass of Dry Sample (g), M_s

53 - 60
Depth of Sample (in)

Sieve No.	Diameter (mm)	Mass of Sieve (g)	Mass retained (sieve + soil) (g)	% Retained	% Passing
4	4.75	503.3	505.6	0%	100%
10	2	464.4	467.7	1%	99%
20	0.85	412.9	423.9	2%	97%
40	0.425	369.8	538.3	27%	70%
60	0.25	353.9	679.1	52%	18%
140	0.106	342.0	448.7	17%	1%
200	0.075	327.9	333.1	1%	1%
Pan		364.2	368.7	1%	

% Passing = 100 - % Retained

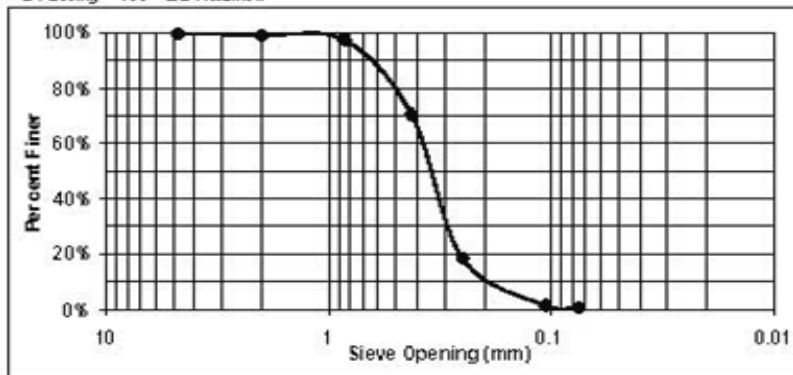

Detailed soils analysis



UNIVERSITY OF NEW MEXICO
DEPARTMENT OF CIVIL ENGINEERING

HYDROMETER ANALYSIS

The University of New Mexico

Project Urban Flood Demonstration Project		Issued By J. Pedra		Date 22 Feb 2007
Soing Identification WCS	Cylinder # 5	Depth (cm) 0 - 4	Time 11:03 AM	Sample Wt. (g) 49.7
Specific Gravity 2.70	Moisture Content (%) 27.3	Notes Soil Bag: 1, Pan 8		

MENISCUS CORRECTION (m)	2
G _s CORRECTION FACTOR (α)	0.99
SUSPENSION CONSTANT (K)	0.01267
CORRECTED SAMPLE WT. (W _s)	36.1
PERCENT PASSING #200 SIEVE	14%

Elapsed Time (min)	Hydrometer Reading		Temperature (°C)	Effective Depth (cm)		Particle Diameter (mm)	% Finer (%)
	Orig.	R _s		R _{a(Corr)}	Corrected		
2	35	33	25	10.9	10.7910	0.0294	12.7%
5	34	32	25	11.1	10.9690	0.0188	12.3%
10	33	31	25	11.2	11.0880	0.0133	11.9%
15	29	27	25	11.9	11.7810	0.0112	10.4%
20	27	25	24	12.2	12.0780	0.0098	9.6%
30	26	24	24	12.4	12.2760	0.0081	9.2%
60	23	21	25	12.9	12.7710	0.0058	8.1%
250	21	19	25	13.2	13.0680	0.0029	7.3%
1440	17	15	25	13.8	13.6620	0.0012	5.8%

Detailed soils analysis



UNIVERSITY OF NEWMEXICO
DEPARTMENT OF CIVIL ENGINEERING

HYDROMETER ANALYSIS

The University of New Mexico

Project Urban Flood Demonstration Project		Requested By J. Pedro		Date 22-Feb-2007
Soiling Identification WCS	Cylinder # 6	Exp. In. (d) 12-Jun	Time 11:23 AM	Sample Wt. (g) 50.0
Specific Gravity 2.70	Mixture Content (%) 11.2	Notes Soil Bag 3, Pan 9		

MENISCUS CORRECTION (m)	<u>2</u>
G _s CORRECTION FACTOR (α)	<u>0.99</u>
SUSPENSION CONSTANT (K)	<u>0.01267</u>
CORRECTED SAMPLE WT. (W _s)	<u>44.4</u>
PERCENT PASSING #200 SIEVE	<u>16%</u>

Elapsed Time (min)	Hydrometer Reading		Temperature (°C)	Effective Depth (cm)		Particle Diameter (mm)	% Finer (%)
	Orig.	R _s		R _{a(Corr)}	Corrected		
2	15	13	25	14.2	14.0580	0.0336	4.6%
5	14	12	25	14.3	14.1570	0.0213	4.3%
10	13	11	25	14.5	14.3550	0.0152	3.9%
15	13	11	25	14.5	14.3550	0.0124	3.9%
20	12	10	25	14.7	14.5530	0.0108	3.6%
30	12	10	25	14.7	14.5530	0.0088	3.6%
60	12	10	25	14.7	14.5530	0.0062	3.6%
250	11	9	25	14.8	14.6520	0.0031	3.2%
1440	10	8	25	15.0	14.8500	0.0013	2.9%

Detailed soils analysis



UNIVERSITY OF NEW
DEPARTMENT OF CIVIL

The University of New Mexico

GRAIN SIZE ANALYSIS

Urban Flood Demonstration Project
Project
I. Pedro & C. LeJeune
Tested By

WCS (Minnow S)
Boring Identification
8 1
Pan No. Soil Bag

Sieve No.	Diameter (mm)	% Passing
4	4.75	100%
10	2	100%
20	0.85	82%
40	0.425	61%
60	0.25	48%
140	0.106	22%
200	0.075	14%
	0.0294	12.7%
	0.0188	12.3%
	0.0133	11.9%
	0.0112	10.4%
	0.0098	9.6%
	0.0081	9.2%
	0.0058	8.1%
	0.0029	7.3%
	0.0012	5.8%

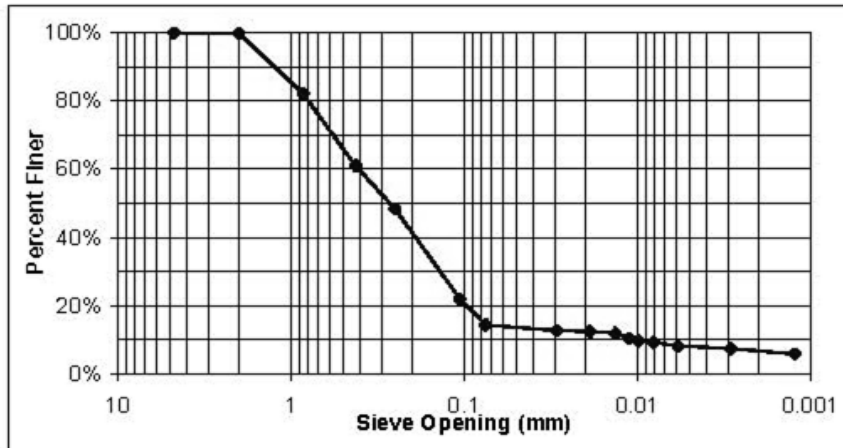

Detailed soils analysis



UNIVERSITY OF NEW MEXICO
DEPARTMENT OF CIVIL ENGINEERING

SOIL BORING LOG INFORMATION

PAGE 1 of 1

Project Name Urban Flood Demonstration Project		Boring Classification ID WCC		Date of Drilling 27-Jul-06		Corresponding Well ID Minnow (WD12) Center		
Boring Drilled By J. Pedro & C. LeJeune		Canopy Rain Gage 0.94"		Open Rain Gage 1.40"		Weather Partly Cloudy		
Boring Location 7 Feet SW of Well		# of Soil Bags Collected 17		Water Table Depth 56"		Final Depth 68"		
				Well Bore Depth N/A		Temperature N/A		
SAMPLE		DESCRIPTION (Visual-Manual Method)						COMMENTS
DEPTH (N)	NUMBER	MOISTURE	COLOR	DRY STRENGTH	DILATANCY	TOUGHNESS	PLASTICITY	
0	0	VM	DBm	M	N	L	L	Organic topsoil
6.5	1	VM	DBm	H	N	M	M	Dark brown sand with organic material present
7.5	2	VM	DBm	H	N	M	H	↓
10.5	3	M	Bm	M	S	H	M	Change in color and less organic material
13.5	4	M	Bm	M	S	M	L	Encountered roots @ 12.5"
14.5	5	M	Bm	L	S	L	L	Encountered roots
17.5	6	M	LBm	L	S	L	N	Change in color and a more sandy appearance
23.5	7	M	LBm	L	S	L	N	Bed sand appearance
29.5	8	M	LBm	L	S	L	N	↓
35.5	9	M	LBm	L	S	L	N	↓
42	10	M	LBm	L	S	L	N	Encountered cobble stones within sample
44	11	M	LBm	L	S	L	N	↓
49	12	VM	Bm	L	S	L	N	Change in color but same appearance
56	13	W	Bm					Water Table reached @ 56". Material too saturated for VMM testing.
58	14	W	Bm					Soil replacing as we advanced. Hard for more precise measurement for depth.
66	15	W	Bm					↓
68	16	W	Bm					↓
68	17	W	Bm					Same appearance, soil replacing coring sample unable to commence any further.
<p>I hereby certify that the information of this form is true and correct to the best of my knowledge</p>								
Signature				Print Name		Date		
				Isaiah Pedro / Christian LeJeune		27-Jul-06		

Detailed soils analysis



UNIVERSITY OF NEW MEXICO
DEPARTMENT OF CIVIL ENGINEERING

WATER CONTENT DETERMINATION

The University of New Mexico

Urban Flood Demonstration Project
Project

I. Pedro
Tested By

November 1, 2006
Date of Testing

November 2, 2006
Date of Dry Weighing

WCC (Minnow C)
Boring Identification

CONTAINER NO. (PAN)	1	2	3	4	5	6	
FIELD TEXTURE	OM	Sand w/Clay	L.Brown Sand	L.Brown Sand	Brown Sand	Brown Sand	
BORING BAG NO.	1	3	6	10	12	15	
DEPTH (in)	0 - 6.5	7.5 - 10.5	14.5 - 17.5	35.5 - 42	44 - 49	58 - 66	
MASS OF CUP + WET SOIL (g)	672.3	447.1	461.7	828.6	723.4	1055.7	
MASS OF CUP + DRY SOIL (g)	555.6	396.6	444.3	825.2	633.0	885.3	
MASS OF CUP (g)	139.2	138.6	139.1	139.2	138.9	139.0	
MASS OF DRY SOIL, Ms (g)	416.4	258.0	305.2	686.0	494.1	746.3	
MASS OF WATER, Mw (g)	116.7	50.5	17.4	3.4	90.4	170.4	
WATER CONTENT, w (%)	28.0%	19.6%	5.7%	0.5%	18.3%	22.8%	

CONTAINER NO. (PAN)							
FIELD TEXTURE							
BORING BAG NO.							
DEPTH (in)							
MASS OF CUP + WET SOIL (g)							
MASS OF CUP + DRY SOIL (g)							
MASS OF CUP (g)							
MASS OF DRY SOIL, Ms (g)							
MASS OF WATER, Mw (g)							
WATER CONTENT, w (%)							

$$w = \frac{M_w}{M_s} (100) \%$$

Detailed soils analysis



UNIVERSITY OF NEW MEXICO
DEPARTMENT OF CIVIL ENGINEERING

GRAIN SIZE ANALYSIS

Urban Flood Demonstration Project
Project

WCC (Minnow C)
Boring Identification

I. Pedro
Tested By

1 1 1
Pan No. Soil Bag No. Sieve Set

November 2, 2006
Date of Testing

OM Material
Field Description of Soil

416.4
Mass of Dry Sample (g), M

0 - 6.5
Depth of Sample (h)

Sieve No.	Diameter (mm)	Mass of Sieve (g)	Mass retained (sieve + soil) (g)	% Retained	% Passing
4	4.75	503.3	548.1	11%	89%
10	2	464.4	568.0	25%	64%
20	0.85	412.9	489.0	18%	46%
40	0.425	369.8	428.3	14%	32%
60	0.25	353.9	410.1	13%	19%
140	0.106	342.0	391.5	12%	7%
200	0.075	327.9	337.3	2%	4%
Pan		364.2	382.6	4%	

% Passing = 100 - % Retained

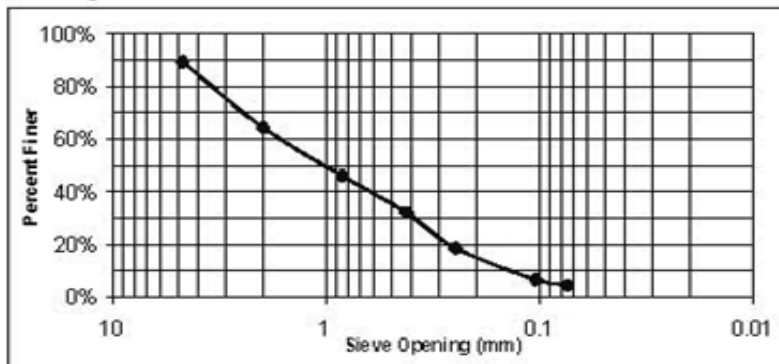

Detailed soils analysis



The University of New Mexico

UNIVERSITY OF NEW MEXICO
DEPARTMENT OF CIVIL ENGINEERING

GRAIN SIZE ANALYSIS

Urban Flood Demonstration Project
Project

WCC (Minnow C)
Boring Identification

L. Pedro
Tested By

2 3 2
Pan No. Soil Bag No. Sieve Set

November 2, 2006
Date of Testing

Sand w/Clay
Field Description of Soil

258
Mass of Dry Sample (g), M_s

7.5 - 10.5
Depth of Sample (m)

Sieve No.	Diameter (mm)	Mass of Sieve (g)	Mass retained (sieve + soil) (g)	% Retained	% Passing
4	4.75	515.9	531.4	6%	94%
10	2	490.9	570.2	31%	63%
20	0.85	412.2	468.1	22%	42%
40	0.425	381.7	413.5	12%	29%
60	0.25	366.5	394.7	11%	18%
140	0.106	342.4	365.3	9%	9%
200	0.075	338.8	343.4	2%	8%
Pan		372.1	395.1	8%	

% Passing = 100 - % Retained

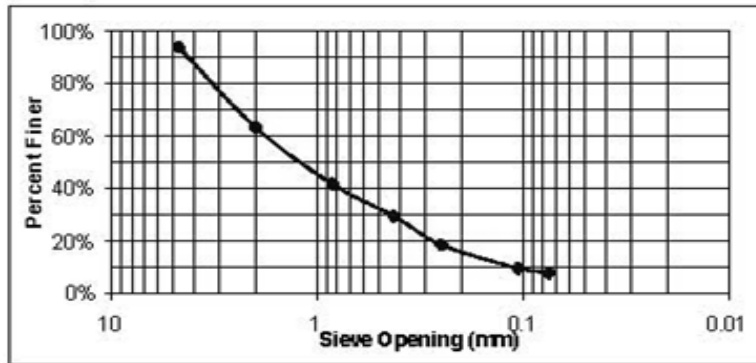

Detailed soils analysis



UNIVERSITY OF NEW MEXICO
DEPARTMENT OF CIVIL ENGINEERING

GRAIN SIZE ANALYSIS

Urban Flood Demonstration Project
Project

WCC (Minnow C)
Boring Identification

I. Pedro
Tested By

3 Pan No. 6 Soil Bag No. 1 Sieve Set

November 2, 2006
Date of Testing

Light Brown Sand
Field Description of Soil

305.2
Mass of Dry Sample (g), M_s

145 - 17.5
Depth of Sample (ft)

Sieve No.	Diameter (mm)	Mass of Sieve (g)	Mass retained (sieve + soil) (g)	% Retained	% Passing
4	4.75	503.3	503.3	0%	100%
10	2	464.4	498.7	11%	89%
20	0.85	412.9	441.5	9%	79%
40	0.425	369.8	410.4	13%	66%
60	0.25	353.9	441.9	29%	37%
140	0.106	342.0	420.1	26%	12%
200	0.075	327.9	339.6	4%	8%
Pan		364.2	389.7	8%	

% Passing = 100 - % Retained

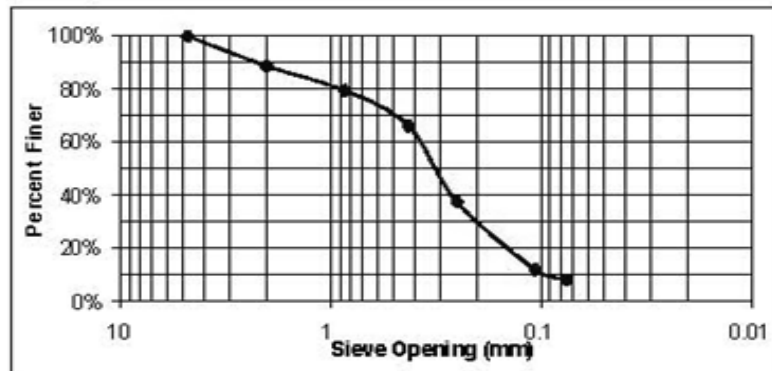

Detailed soils analysis



UNIVERSITY OF NEW MEXICO
DEPARTMENT OF CIVIL ENGINEERING

GRAIN SIZE ANALYSIS

The University of New Mexico

Urban Flood Demonstration Project
Project

WCC (Minnow C)
Boring Identification

I. Pedro
Tested By

4 10 2
Pan No. Soil Bag No. Sieve Set

November 2, 2006
Date of Testing

Light Brown Sand
Field Description of Soil

686
Mass of Dry Sample (g), M

35.5 - 42
Depth of Sample (ft)

Sieve No.	Diameter (mm)	Mass of Sieve (g)	Mass retained (sieve + soil) (g)	% Retained	% Passing
4	4.75	515.9	543.8	4%	96%
10	2	490.9	500.8	1%	94%
20	0.85	412.2	433.9	3%	91%
40	0.425	381.7	551.8	25%	67%
60	0.25	366.5	687.3	47%	20%
140	0.106	342.4	467.9	18%	1%
200	0.075	338.8	345.7	1%	0%
Pan		372.1	376.4	0%	

% Passing = 100 - % Retained

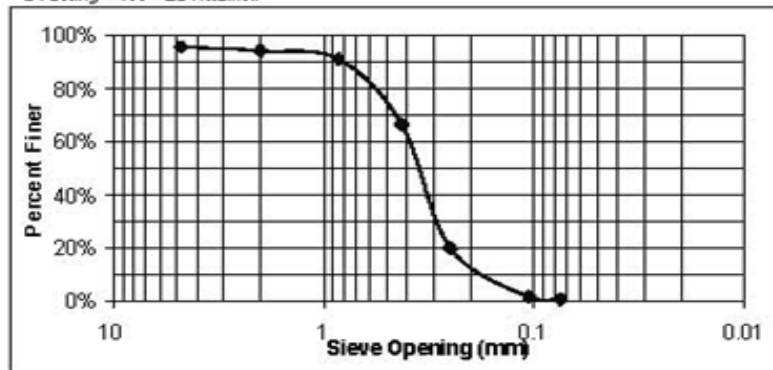

Detailed soils analysis



UNIVERSITY OF NEW MEXICO
DEPARTMENT OF CIVIL ENGINEERING

GRAIN SIZE ANALYSIS

Urban Flood Demonstration Project
Project

WCC (Minnow C)
Boring Identification

I. Pedro
Tested By

5 12 1
Pan No. Soil Bag No. Sieve Set

November 2, 2006
Date of Testing

Brown Sand
Field Description of Soil

494.1
Mass of Dry Sample (g), M

44 - 49
Depth of Sample (n)

Sieve No.	Diameter (mm)	Mass of Sieve (g)	Mass retained (sieve + soil) (g)	% Retained	% Passing
4	4.75	503.3	504.7	0%	100%
10	2	464.4	467.1	1%	99%
20	0.85	412.9	422.6	2%	97%
40	0.425	369.8	473.1	21%	76%
60	0.25	353.9	610.4	52%	24%
140	0.106	342.0	447.6	21%	3%
200	0.075	327.9	337.3	2%	1%
Pan		364.2	370.2	1%	

% Passing = 100 - % Retained

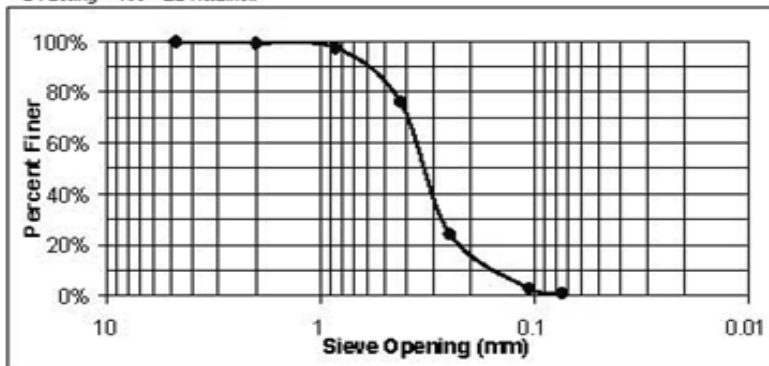

Detailed soils analysis



UNIVERSITY OF NEW MEXICO
DEPARTMENT OF CIVIL ENGINEERING

GRAIN SIZE ANALYSIS

Urban Flood Demonstration Project
Project

WCC (Minnow C)
Boring Identification

I. Pedro
Tested By

6 15 2
Pan No. Soil Bag No. Sieve Set

November 2, 2006
Date of Testing

Brown Sand
Field Description of Soil

746.3
Mass of Dry Sample (g), M

58 - 66
Depth of Sample (ft)

Sieve No.	Diameter (mm)	Mass of Sieve (g)	Mass retained (sieve + soil) (g)	% Retained	% Passing
4	4.75	515.9	529	2%	98%
10	2	490.9	507.8	2%	96%
20	0.85	412.2	460.1	6%	90%
40	0.425	381.7	630.9	33%	56%
60	0.25	366.5	684.4	43%	14%
140	0.106	342.4	432.1	12%	2%
200	0.075	338.8	345.7	1%	1%
Pan		372.1	378.1	1%	

% Passing = 100 - % Retained

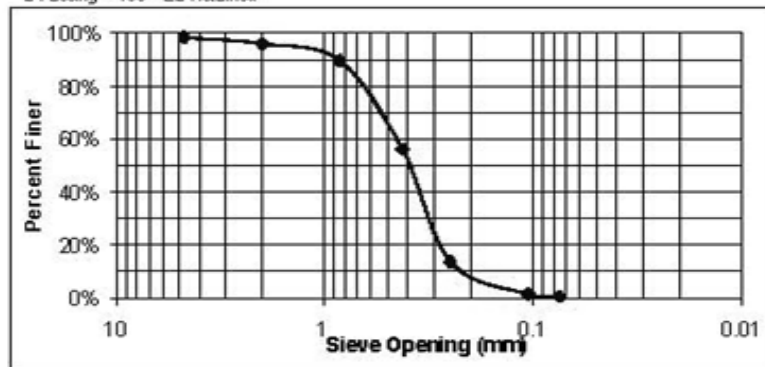

Detailed soils analysis



The University of New Mexico

UNIVERSITY OF NEW MEXICO
DEPARTMENT OF CIVIL ENGINEERING

FIELD DENSITY ANALYSIS
SAND-CONE METHOD

Urban Flood Demostration Project	March 15, 2007
Project	Date
WCC (Minnow C Well)	0 - 19
Location of Sampling	Depth of Sample Layer, (cm)
Isaiah Pedro	Poorly Graded Sand
Test Performed By	Description of Soil

Calibration Data

Sand Used Ottawa Sand

Type of Vol. Measure	<u>N/A</u>	Vol., V_m (cm ³)	<u>N/A</u>
----------------------	------------	--------------------------------	------------

Mass of sand to fill Vol. Measure	Trial No. 1	<u>-</u>
	Trial No. 2	<u>-</u>
	Trial No. 3	<u>-</u>
	Average Mass M_s	<u>-</u>
Density of sand (g/cm ³), $\rho_{sand} = M_s/V_m =$		<u>1.62</u>

Mass of sand to fill cone	Jug ID	<u>1</u>
Mass of filled jug + cone, (g)		<u>6655.1</u>
Mass after trial No. 1, (g)	6263.6	Mass used, (g) <u>391.5</u>
Mass after trial No. 2, (g)	5859.2	Mass used, (g) <u>404.4</u>
Mass after trial No. 3, (g)	5464.6	Mass used, (g) <u>394.6</u>
Average mass to fill cone, (g)		<u>396.8</u>

Field Data

Mass of jug + cone before use, (g)	<u>6567.3</u>
Mass of jug + cone after use, (g)	<u>5313.4</u>
Mass of sand used (hole + cone), (g)	<u>1253.9</u>
Mass of sand in cone (from calibration), (g)	<u>396.8</u>
Mass of sand in hole, M (g)	<u>857.1</u>
Vol. of hole, $V_h = M/\rho_{sand}$ (cm ³)	<u>529.1</u>
$\rho_{wet} = M/V_h$ (g/cm ³)	<u>1.25</u>

Laboratory Data from Field Test

Mass of wet soil + can (g)	<u>684.2</u>
Mass of can, (g)	<u>21.4</u>
Mass of wet soil, M' (g)	<u>662.8</u>
Mass of wet soil + pan (g)	<u>800.7</u>
Mass of dry soil + pan (g)	<u>637.3</u>
Mass of pan (g)	<u>139.2</u>
Mass of dry soil (g)	<u>498.1</u>
Water content, w%	<u>75.20%</u>

Unit Weight of Soil

Wet $\gamma_{wet} = \rho_{wet} \times 9.807 =$	<u>12.29</u>	kN/m³
Dry $\gamma_{dry} = \gamma_{wet} / (1+w) =$	<u>7.02</u>	kN/m³

Detailed soils analysis



UNIVERSITY OF NEW MEXICO
DEPARTMENT OF CIVIL ENGINEERING

SOIL BORING LOG INFORMATION

PAGE 1 of 1

The University of New Mexico

Project Name Urban Flood Demonstration Project		Boring Classification ID WCE		Date of Drilling 2-Aug-06		Corresponding Well ID Minnow (WD12) East		
Boring Drilled By I. Pedro and C. LeJeune		Canopy Rain Gage 1.6"	Open Rain Gage 2.35"	Weather Sunny w/Clouds				
Boring Location 3 ft. SW of Well		# of Soil Bags Collected 15	Water Table Depth 47"	Final Depth 68"	Well Header Depth 47"	Temperature N/A		
DEPTH (IN)	SAMPLE NUMBER	DESCRIPTION (Visual-Manual Method)						COMMENTS
		MOISTURE	COLOR	DRY STRENGTH	DILATANCY	TOUGHNESS	PLASTICITY	
0	0	M	DBm	N/A				Organic Material around coring area, lots of twigs and roots
7	1	VM	DBm	VH	N	H	H	Organic Material
14	2	VM	Bm	VH	N	H	H	↓
19	3	VM	Bm	H	S	L	M	Finer appearance than previous (encountered root near ~15-16" in depth)
25	4	VM	Bm	H	S	L	L	↓
30.5	5	VM	Bm	M	R	L	L	↓
36	6	VM	Bm	L	R	L	L	↓
37	7	VM	OBm	L	S	M	M	Change in color. Cobble stones & gravel material present
41.5	8	VM	OBm	NP	R	L	L	↓
43.5	9	VM	Bm					Too saturated to use VMM testing parameters.
51	10	W	Bm					Water Table reached @ 47". Very saturated with a more gravelly appearance.
59	11	W	Gr					
63	12	W	LGr					
66	13	W	Gr					
68	14	W	Gr					
68	15	W	Gr					↓
								**Rained Night Before
I hereby certify that the information of this form is true and correct to the best of my knowledge								
Signature			Print Name			Date		
			Isaiah Pedro / Chnstian LeJeune			2-Aug-06		

Detailed soils analysis



The University of New Mexico

UNIVERSITY OF NEW MEXICO
DEPARTMENT OF CIVIL ENGINEERING

WATER CONTENT DETERMINATION

Urban Flood Demonstration Project
Project

J. Pedro
Tested By

November 6, 2006
Date of Testing

November 7, 2006
Date of Dry Weighing

WCE (Minnow E)
Boring Identification

CONTAINER NO. (PAN)	1	2	3	4	5	6	7
FIELD TEXTURE	DM	Sand w/Clay	Sand w/Clay	Sand w/Gravel	Sand w/Gravel	Gray Sand w/Gravel	Gray Sand w/Gravel
BORING BAG NO.	1	3	6	8	10	11	14
DEPTH (in)	0 - 7	14 - 19	30.5 - 36	37 - 41.5	43.5 - 51	51 - 59	66 - 68
MASS OF CUP + WET SOIL (g)	656.2	728.5	752.9	681.5	1010.2	1079.7	1005.1
MASS OF CUP + DRY SOIL (g)	513.9	631.4	627.8	626.0	867.0	924.3	851.6
MASS OF CUP (g)	139.2	138.6	139.1	139.2	138.9	139.0	137.8
MASS OF DRY SOIL, M_s (g)	374.7	492.8	488.7	486.8	728.1	785.3	713.8
MASS OF WATER, M_w (g)	142.3	97.1	125.1	55.5	143.2	155.4	153.5
WATER CONTENT, w (%)	38.0%	19.7%	25.6%	11.4%	19.7%	19.8%	21.5%

CONTAINER NO. (PAN)							
FIELD TEXTURE							
BORING BAG NO.							
DEPTH (in)							
MASS OF CUP + WET SOIL (g)							
MASS OF CUP + DRY SOIL (g)							
MASS OF CUP (g)							
MASS OF DRY SOIL, M_s (g)							
MASS OF WATER, M_w (g)							
WATER CONTENT, w (%)							

$$w = \frac{M_w}{M_s} (100) \%$$

Detailed soils analysis



UNIVERSITY OF NEW MEXICO
DEPARTMENT OF CIVIL ENGINEERING

GRAIN SIZE ANALYSIS

Urban Flood Demonstration Project
Project

WCE (Minnow E)
Boring Identification

I. Pedro & C. LeJeune
Tested By

1 1 1
Pan No. Soil Bag No. Sieve Set

November 7, 2006
Date of Testing

OM Material
Field Description of Soil

3747
Mass of Dry Sample (g), M

0 - 7
Depth of Sample (m)

Sieve No.	Diameter (mm)	Mass of Sieve (g)	Mass retained (sieve + soil) (g)	% Retained	% Passing
4	4.75	503.3	507.9	1%	99%
10	2	464.4	475.5	3%	96%
20	0.85	412.9	522.3	29%	67%
40	0.425	369.8	435.5	18%	49%
60	0.25	353.9	386.9	9%	40%
140	0.106	342.0	379.8	10%	30%
200	0.075	327.9	348.5	5%	25%
Pan		364.2	459.8	25%	

% Passing = 100 - % Retained

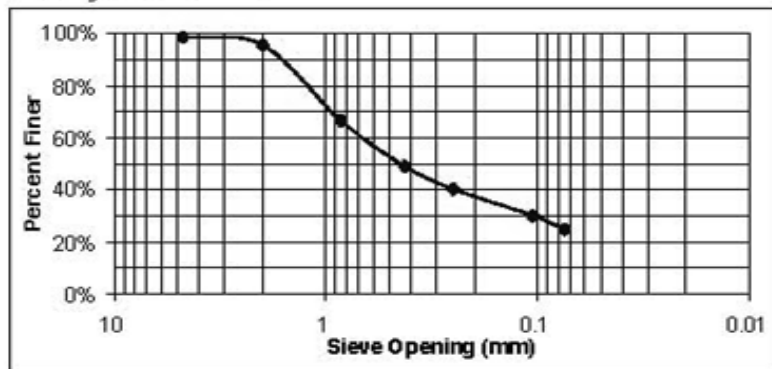

Detailed soils analysis



UNIVERSITY OF NEW MEXICO
DEPARTMENT OF CIVIL ENGINEERING

GRAIN SIZE ANALYSIS

Urban Flood Demonstration Project
Project

WCE (Minnow E)
Boring Identification

I. Pedro & C. LaJeune
Tested By

2 3 2
Pan No. Soil Bag No. Sieve Set

November 7, 2006
Date of Testing

Sand with Clay
Field Description of Soil

492.8
Mass of Dry Sample (g), M

14 - 19
Depth of Sample (m)

Sieve No.	Diameter (mm)	Mass of Sieve (g)	Mass retained (sieve + soil) (g)	% Retained	% Passing
4	4.75	515.9	515.9	0%	100%
10	2	490.9	491.0	0%	100%
20	0.85	412.2	446.5	7%	93%
40	0.425	381.7	449.6	14%	79%
60	0.25	366.5	429.4	13%	66%
140	0.106	342.4	518.8	36%	31%
200	0.075	338.8	400.1	12%	18%
Pan		364.0	455.8	18%	

% Passing = 100 - % Retained

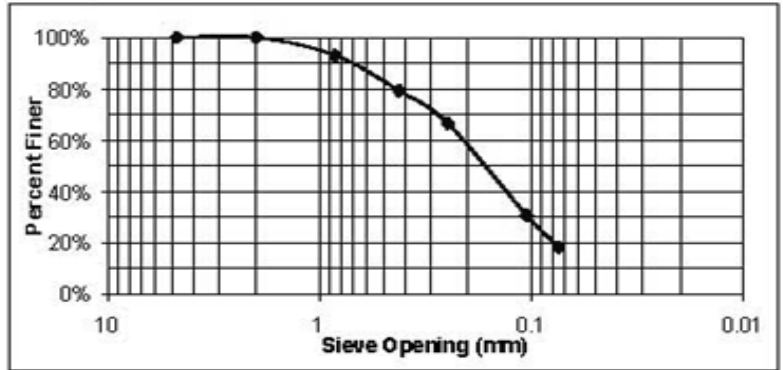

Detailed soils analysis



The University of New Mexico

UNIVERSITY OF NEW MEXICO
DEPARTMENT OF CIVIL ENGINEERING

GRAIN SIZE ANALYSIS

Urban Flood Demonstration Project
Project

WCE (Minnow E)
Boiling Identification

I. Pedro & C. LaJeune
Tested By

3 6 1
Pan No. Soil Bag No. Sieve Set

November 7, 2006
Date of Testing

Sand with Clay
Field Description of Soil

488.7
Mass of Dry Sample (g), M_s

30.5 - 36
Depth of Sample (in)

Sieve No.	Diameter (mm)	Mass of Sieve (g)	Mass retained (sieve + soil) (g)	% Retained	% Passing
4	4.75	503.3	508.0	1%	99%
10	2	464.4	473.5	2%	97%
20	0.85	412.9	432.2	4%	93%
40	0.425	369.8	384.7	3%	90%
60	0.25	353.9	373.6	4%	86%
140	0.106	342.0	629.9	59%	27%
200	0.075	327.9	387.5	12%	15%
Pan		364.2	440.9	15%	

% Passing = 100 - Σ% Retained

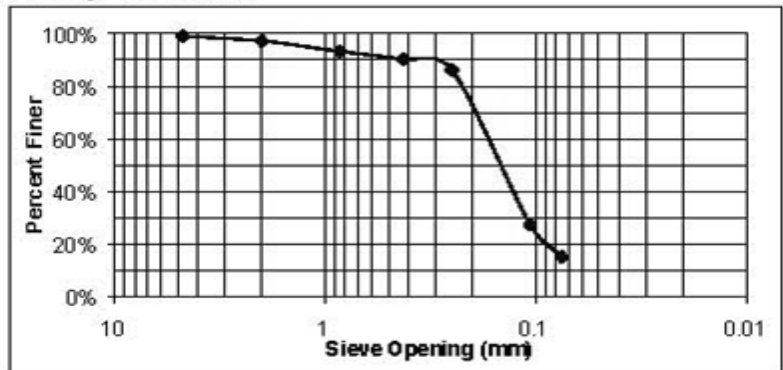

Detailed soils analysis



UNIVERSITY OF NEW MEXICO
DEPARTMENT OF CIVIL ENGINEERING

GRAIN SIZE ANALYSIS

Urban Flood Demonstration Project
Project

WCE (Minnow E)
Boring Identification

L. Pedro & C. LeJeune
Tested By

4 Pan No. 8 Soil Bag No. 2 Sieve Set

November 7, 2006
Date of Testing

Sand with Gravel
Field Description of Soil

486.8
Mass of Dry Sample (g), M_s

37 - 41.5
Depth of Sample (m)

Sieve No.	Diameter (mm)	Mass of Sieve (g)	Mass retained (sieve + soil) (g)	% Retained	% Passing
4	4.75	515.9	553.5	8%	92%
10	2	490.9	511.7	4%	88%
20	0.85	412.2	452.3	8%	80%
40	0.425	381.7	569.6	39%	41%
60	0.25	366.5	491.8	26%	15%
140	0.106	342.4	396.6	11%	4%
200	0.075	338.8	350.7	2%	2%
Pan		364.0	376.5	2%	

% Passing = 100 - % Retained

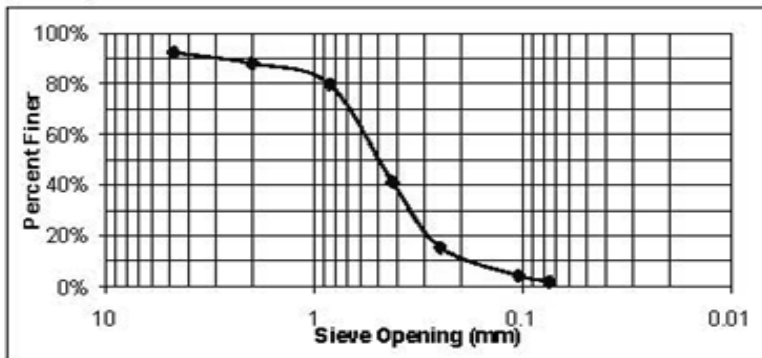

Detailed soils analysis



UNIVERSITY OF NEW MEXICO
DEPARTMENT OF CIVIL ENGINEERING

GRAIN SIZE ANALYSIS

Urban Flood Demonstration Project
Project

WCE (Minnow E)
Boring Identification

I. Pedro & C. LeJeune
Tested By

5 Pan No. 10 Soil Bag No. 1 Sieve Set

November 7, 2006
Date of Testing

Sand with Gravel
Field Description of Soil

728.1
Mass of Dry Sample (g), M

43.5 - 51
Depth of Sample (m)

Sieve No.	Diameter (mm)	Mass of Sieve (g)	Mass retained (sieve + soil) (g)	% Retained	% Passing
4	4.75	503.3	547.2	6%	94%
10	2	464.4	544.0	11%	83%
20	0.85	412.9	526.7	16%	67%
40	0.425	369.8	582.1	29%	38%
60	0.25	353.9	510.9	22%	17%
140	0.106	342.0	438.6	13%	3%
200	0.075	327.9	341.4	2%	2%
Pan		364.2	377.6	2%	

% Passing = 100 - % Retained

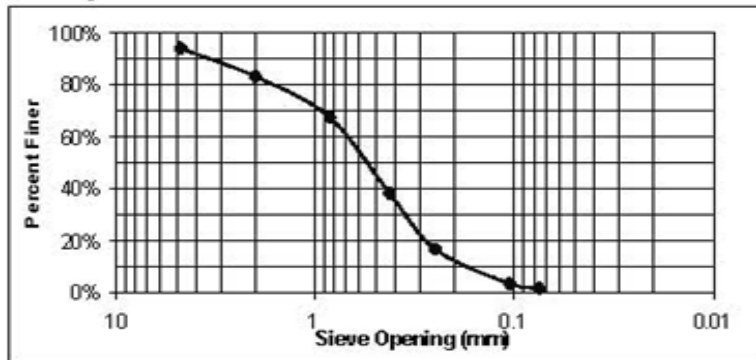

Detailed soils analysis



UNIVERSITY OF NEW MEXICO
DEPARTMENT OF CIVIL ENGINEERING

GRAIN SIZE ANALYSIS

Urban Flood Demonstration Project
Project

WCE (Minnow E)
Boring Identification

L. Pedro & C. LeJeune
Tested By

6 11 2
Pan No. Soil Bag No. Sieve Set

November 7, 2006
Date of Testing

Gray Sand with Gravel
Field Description of Soil

785.3
Mass of Dry Sample (g), M_s

51 - 59
Depth of Sample (ft)

Sieve No.	Diameter (mm)	Mass of Sieve (g)	Mass retained (sieve + soil) (g)	% Retained	% Passing
4	4.75	515.9	599.8	11%	89%
10	2	490.9	531.0	5%	84%
20	0.85	412.2	488.5	10%	74%
40	0.425	381.7	556.0	22%	52%
60	0.25	366.5	641.9	35%	17%
140	0.106	342.4	467.5	16%	1%
200	0.075	338.8	345.4	1%	0%
Pan		372.1	377.9	0%	

% Passing = 100 - % Retained

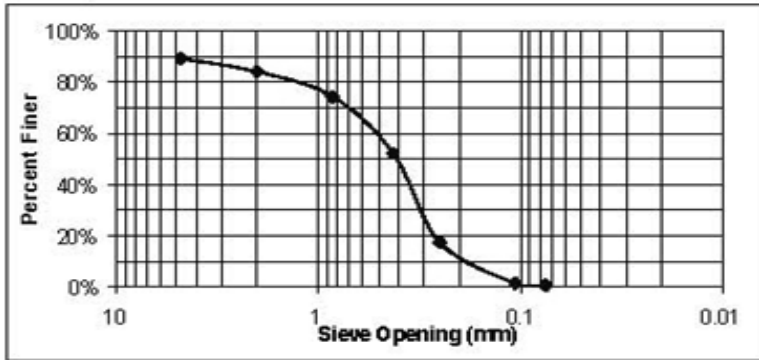

Detailed soils analysis



UNIVERSITY OF NEW MEXICO
DEPARTMENT OF CIVIL ENGINEERING

GRAIN SIZE ANALYSIS

Urban Flood Demonstration Project
Project

WCE (Minnow E)
Boring Identification

I. Pedro & C. LaJeune
Tested By

7 Pan No. 14 Soil Bag No. 1 Sieve Set

November 7, 2006
Date of Testing

Gray Sand with Gravel
Field Description of Soil

713.8
Mass of Dry Sample (g), M

66 - 68
Depth of Sample (n)

Sieve No.	Diameter (mm)	Mass of Sieve (g)	Mass retained (sieve + soil) (g)	% Retained	% Passing
4	4.75	503.3	546.6	6%	94%
10	2	464.4	497.4	5%	89%
20	0.85	412.9	479.8	9%	80%
40	0.425	369.8	582.6	30%	50%
60	0.25	353.9	578.9	32%	19%
140	0.106	342.0	460.5	17%	2%
200	0.075	327.9	335.9	1%	1%
Pan		364.2	371.2	1%	

% Passing = 100 - % Retained

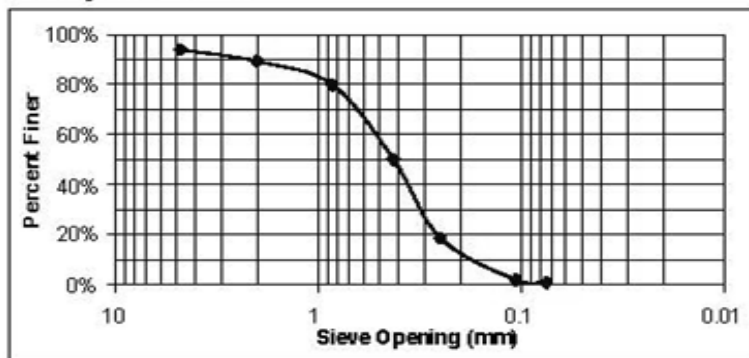

Detailed soils analysis

Appendix E: Bobcat (WU22) Core Data Sheets



UNIVERSITY OF NEW MEXICO
DEPARTMENT OF CIVIL ENGINEERING

SOIL BORING LOG INFORMATION

PAGE _____ of _____

The University of New Mexico

Project Name Urban Flood Demonstration Project		Boring Classification ID WNN		Date of Drilling 9-Aug-06		Corresponding Well ID Bobcat (WU22) North		
Boring Drilled By I. Pedro & C. LeJeune		Canopy Rain Gage N/A		Open Rain Gage N/A		Weather Sunny		
Boring Location 3 Feet SW of Well		# of Soil Bags Collected 16		Water Table Depth 61"		Final Depth 67.5"		
				Well Bender Depth 57.5"		Timbers Use 92 F		
SAMPLE		DESCRIPTION (Visual-Manual Method)						COMMENTS
DEPTH (ft)	NUMBER	MOISTURE	COLOR	DRY STRENGTH	DILATANCY	TOUGHNESS	PLASTICITY	
0	0	M						Leaves, twigs and organic material on top surface
1	1	M						Organic material present
7.5	2	M						Encountered roots @ 7.5"
14	3	M						Encountered roots and steel wires (discarded wires)
21.5	4	M						↓
25	5	M						Sandy appearance
31	6	M						Encountered roots
33	7	M						↓
36.5	8	M						More sandy appearance
38.5	9	M						↓
42.5	10	VM						Clayey appearance and smell
47.5	11	VM						Sandy appearance
50	12	VM						↓
54.5	13	VM						Clayey appearance, reddish-brown clumpy appearance
57	14	VM						↓
61	15	VM						Clay appearance and smell. Water table reached @ 61"
67.5	16	W						Clay with sand appearance
								**NO FIELD CLASSIFICATION PERFORMED
I hereby certify that the information of this form is true and correct to the best of my knowledge								
Signature				Print Name		Date		
				Isaiah Pedro / Christian LeJeune		9-Aug-06		

Detailed soils analysis



UNIVERSITY OF NEW MEXICO
DEPARTMENT OF CIVIL ENGINEERING

WATER CONTENT DETERMINATION

The University of New Mexico

Urban Flood Demonstration Project
Project

I. Pedro & C. LeJeune
Tested By

November 13, 2006
Date of Testing

November 14, 2006
Date of Dry Weighing

WNN (Bobcat N)
Boring Identification

CONTAINER NO. (CUP)	1	2	3	4	5	6	7
FIELD TEXTURE	OM	Brown Sand	Brown Sand	Brown Sand	L. Brown Sand	Sand w/Clay	L. Brown Sand
BORING BAG NO.	1	2	5	7	8	10	11
DEPTH (ft)	0 - 1	1 - 7.5	21.5 - 25	31 - 33	33 - 36.5	38.5 - 42.5	42.5 - 47.5
MASS OF CUP + WET SOIL (g)	213.8	631.4	669.7	319.9	507.0	620.1	553.1
MASS OF CUP + DRY SOIL (g)	193.6	527.2	575.7	289.8	453.3	515.9	480.5
MASS OF CUP (g)	139.2	138.6	139.1	139.2	138.9	139.0	137.8
MASS OF DRY SOIL, Ms (g)	54.4	388.6	436.6	150.6	314.4	376.9	342.7
MASS OF WATER, Mw (g)	20.2	104.2	94.0	30.1	53.7	104.2	72.6
WATER CONTENT, w (%)	37.1%	26.8%	21.5%	20.0%	17.1%	27.6%	21.2%

CONTAINER NO. (CUP)	8	9					
FIELD TEXTURE	Sand w/Clay	Gray Sand					
BORING BAG NO.	13	15					
DEPTH (ft)	50 - 54.5	57 - 61					
MASS OF CUP + WET SOIL (g)	550.5	616.4					
MASS OF CUP + DRY SOIL (g)	438.5	481.1					
MASS OF CUP (g)	138.0	139.4					
MASS OF DRY SOIL, Ms (g)	300.5	341.7					
MASS OF WATER, Mw (g)	112.0	135.3					
WATER CONTENT, w (%)	37.3%	39.6%					

$$w = \frac{M_w}{M_s} (100) \%$$

Detailed soils analysis



UNIVERSITY OF NEW MEXICO
DEPARTMENT OF CIVIL ENGINEERING

GRAIN SIZE ANALYSIS

Urban Flood Demonstration Project
Project

WNN (Bobcat N)
Boring Identification

I. Pedro & C. LeJeune
Tested By

1 1 1
Pan No. Soil Bag No. Sieve Set

November 14, 2006
Date of Testing

OM
Field Description of Soil

54.4
Mass of Dry Sample (g), M_s

0 - 1
Depth of Sample (m)

Sieve No.	Diameter (mm)	Mass of Sieve (g)	Mass retained (sieve + soil) (g)	% Retained	% Passing
4	4.75	503.2	503.3	0%	100%
10	2	464.4	467.3	5%	94%
20	0.85	413.1	422.0	16%	78%
40	0.425	370.0	377.6	14%	64%
60	0.25	354.0	360.8	13%	52%
140	0.106	342.0	355.6	25%	27%
200	0.075	327.7	333.6	11%	16%
Pan		364.0	372.1	16%	

% Passing = 100 - % Retained

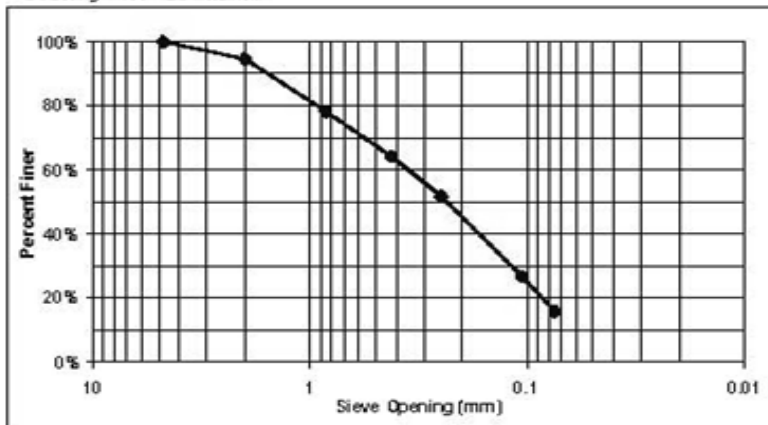

Detailed soils analysis



UNIVERSITY OF NEW MEXICO
DEPARTMENT OF CIVIL ENGINEERING

GRAIN SIZE ANALYSIS

Urban Flood Demonstration Project
Project

WNN (Bobcat N)
Boring Identification

I. Pedro & C. LeJeune
Tested By

2 2 2
Pan No. Soil Bag No. Sieve Set

November 14, 2006
Date of Testing

Brown Sand
Field Description of Soil

388.6
Mass of Dry Sample (g), M

1 - 7.5
Depth of Sample (ft)

Sieve No.	Diameter (mm)	Mass of Sieve (g)	Mass retained (sieve + soil) (g)	% Retained	% Passing
4	4.75	515.7	524.3	2%	98%
10	2	490.7	555.8	17%	81%
20	0.85	412.6	455.9	11%	70%
40	0.425	381.9	412.2	8%	62%
60	0.25	366.8	390.2	6%	56%
140	0.106	342.5	439.4	25%	31%
200	0.075	338.7	392.3	14%	17%
Pan		364.0	430.8	17%	

% Passing = 100 - % Retained

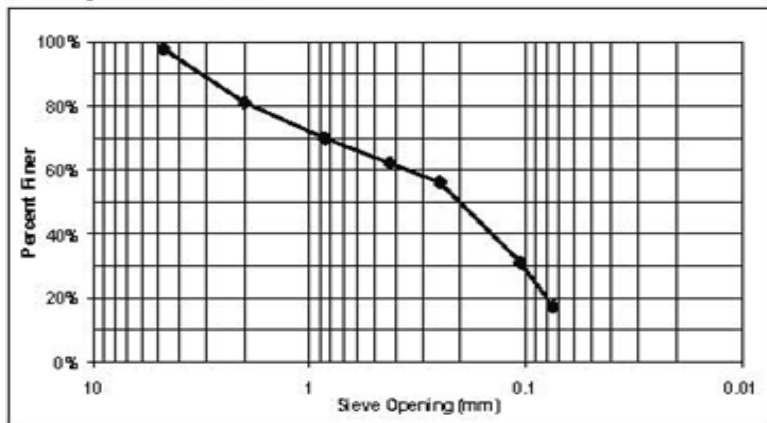

Detailed soils analysis



The University of New Mexico

UNIVERSITY OF NEW MEXICO
DEPARTMENT OF CIVIL ENGINEERING

GRAIN SIZE ANALYSIS

Urban Flood Demonstration Project
Project

WNN (Bobcat N)
Boring Identification

I. Pedro & C. LeJeune
Tested By

3 5 1
Pan No. Soil Bag No. Sieve Set

November 14, 2006
Date of Testing

Brown Sand
Field Description of Soil

436.6
Mass of Dry Sample (g), M

21.5 - 25
Depth of Sample (m)

Sieve No.	Diameter (mm)	Mass of Sieve (g)	Mass retained (sieve + soil) (g)	% Retained	% Passing
4	4.75	503.2	503.3	0%	100%
10	2	464.4	464.6	0%	100%
20	0.85	413.1	462.7	11%	89%
40	0.425	370.0	443.4	17%	72%
60	0.25	354.0	395.7	10%	62%
140	0.106	342.0	413.7	16%	46%
200	0.075	327.7	382.0	12%	33%
Pan		364.0	506.8	33%	

% Passing = 100 - % Retained

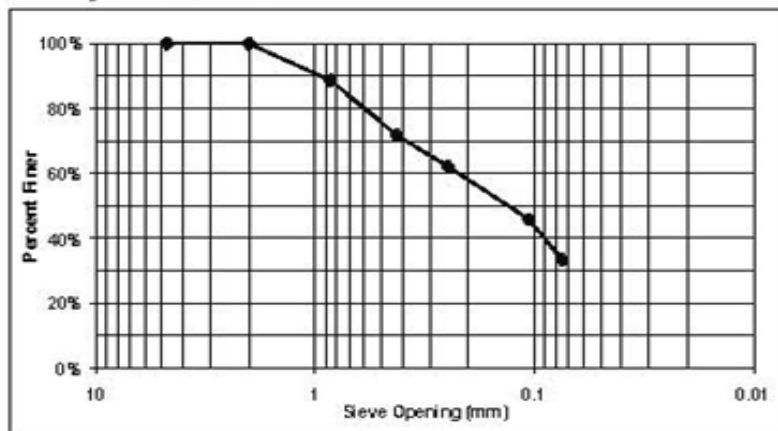

Detailed soils analysis



The University of New Mexico

UNIVERSITY OF NEW MEXICO
DEPARTMENT OF CIVIL ENGINEERING

GRAIN SIZE ANALYSIS

Urban Flood Demonstration Project
Project

WNN (Bobcat N)
Boring Identification

I. Pedro & C. LeJeune
Tested By

4 Pan No. 7 Soil Bag No. 2 Sieve Set

November 14, 2006
Date of Testing

Brown Sand
Field Description of Soil

150.6
Mass of Dry Sample (g), M

31 - 33
Depth of Sample (m)

Sieve No.	Diameter (mm)	Mass of Sieve (g)	Mass retained (sieve + soil) (g)	% Retained	% Passing
4	4.75	515.7	515.7	0%	100%
10	2	490.7	491.0	0%	100%
20	0.85	412.6	428.4	10%	89%
40	0.425	381.9	405.4	16%	74%
60	0.25	366.8	381.8	10%	64%
140	0.106	342.5	367.8	17%	47%
200	0.075	338.7	356.3	12%	35%
Pan		364.0	417.2	35%	

% Passing = 100 - % Retained

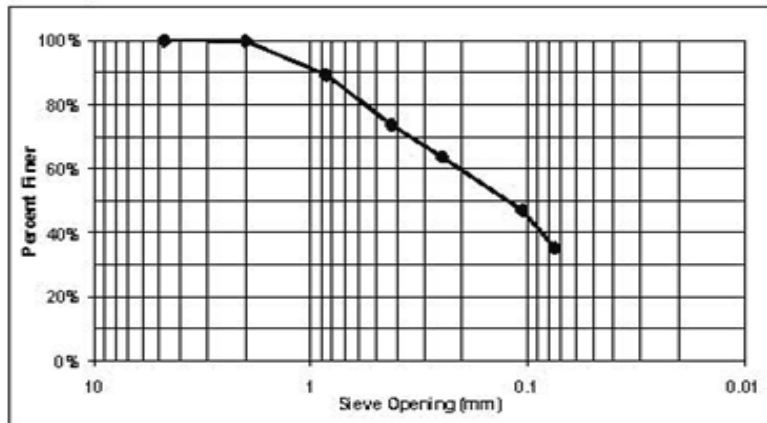

Detailed soils analysis



The University of New Mexico

UNIVERSITY OF NEW MEXICO
DEPARTMENT OF CIVIL ENGINEERING

GRAIN SIZE ANALYSIS

Urban Flood Demonstration Project
Project

WNN (Bobcat N)
Boring Identification

I. Pedro & C. LeJeune
Tested By

5 8 1
Pan No. Soil Bag No. Sieve Set

November 14, 2006
Date of Testing

Light Brown Sand
Field Description of Soil

314.4
Mass of Dry Sample (g), M

33 - 36.5
Depth of Sample (h)

Sieve No.	Diameter (mm)	Mass of Sieve (g)	Mass retained (sieve + soil) (g)	% Retained	% Passing
4	4.75	503.2	503.4	0%	100%
10	2	464.4	486.3	7%	93%
20	0.85	413.1	453.8	13%	80%
40	0.425	370.0	392.3	7%	73%
60	0.25	354.0	368.7	5%	68%
140	0.106	342.0	389.3	15%	53%
200	0.075	327.7	385.8	18%	35%
Pan		364.0	473.9	35%	

% Passing = 100 - % Retained

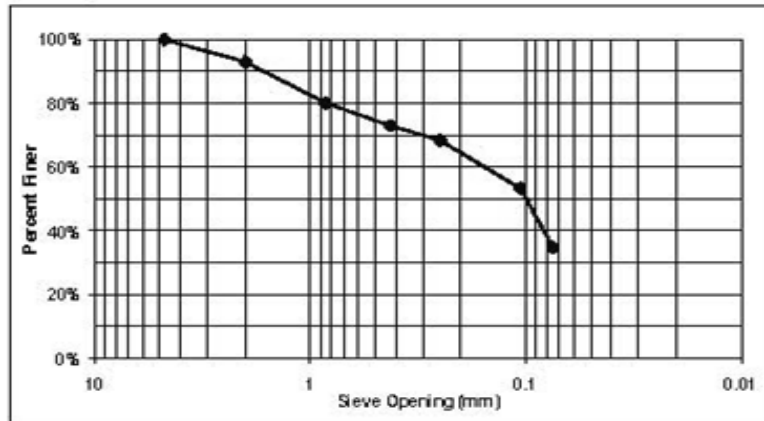

Detailed soils analysis



The University of New Mexico

UNIVERSITY OF NEW MEXICO
DEPARTMENT OF CIVIL ENGINEERING

GRAIN SIZE ANALYSIS

Urban Flood Demonstration Project
Projec

WNN (Bobcat N)
Boring Identification

I. Pedro & C. LeJeune
Tested By

6 10 2
Pan No. Soil Bag No. Sieve Set

November 14, 2006
Date of Testing

Sand with Clay
Field Description of Soil

376.9
Mass of Dry Sample (g), M

38.5 - 42.5
Depth of Sample (ft)

Sieve No.	Diameter (mm)	Mass of Sieve (g)	Mass retained (sieve + soil) (g)	% Retained	% Passing
4	4.75	515.7	516.0	0%	100%
10	2	490.7	498.5	2%	98%
20	0.85	412.6	505.2	25%	73%
40	0.425	381.9	444.8	17%	57%
60	0.25	366.8	398.8	8%	48%
140	0.106	342.5	379.8	10%	38%
200	0.075	338.7	358.7	5%	33%
Pan		364.0	486.3	33%	

% Passing = 100 - % Retained

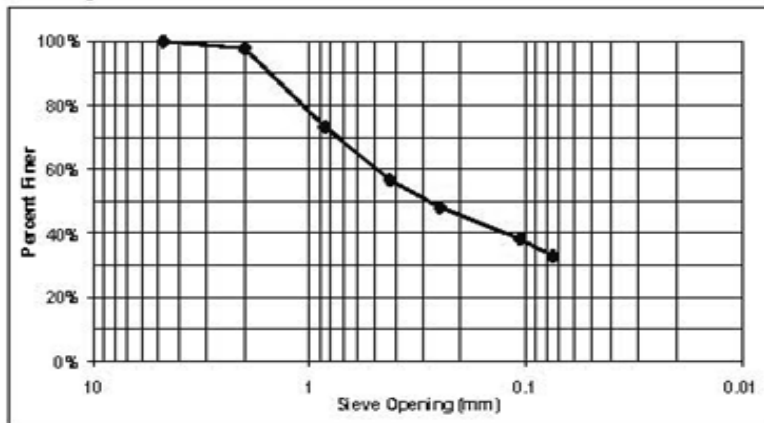

Detailed soils analysis



The University of New Mexico

UNIVERSITY OF NEW MEXICO
DEPARTMENT OF CIVIL ENGINEERING

GRAIN SIZE ANALYSIS

Urban Flood Demonstration Project
Project

WNN (Bobcat N)
Boring Identification

L. Pedro & C. LeJeune
Tested By

7 Pan No. 11 Soil Bag No. 1 Sieve Set

November 14, 2006
Date of Testing

Light Brown Sand
Field Description of Soil

342.7
Mass of Dry Sample (g), M_s

42.5 - 47.5
Depth of Sample (m)

Sieve No.	Diameter (mm)	Mass of Sieve (g)	Mass retained (sieve + soil) (g)	% Retained	% Passing
4	4.75	503.2	503.2	0%	100%
10	2	464.4	465.8	0%	100%
20	0.85	413.1	447.7	10%	89%
40	0.425	370.0	408.9	11%	78%
60	0.25	354.0	382.3	8%	70%
140	0.106	342.0	405.1	18%	51%
200	0.075	327.7	390.2	18%	33%
Pan		364.0	478.3	33%	

% Passing = 100 - % Retained

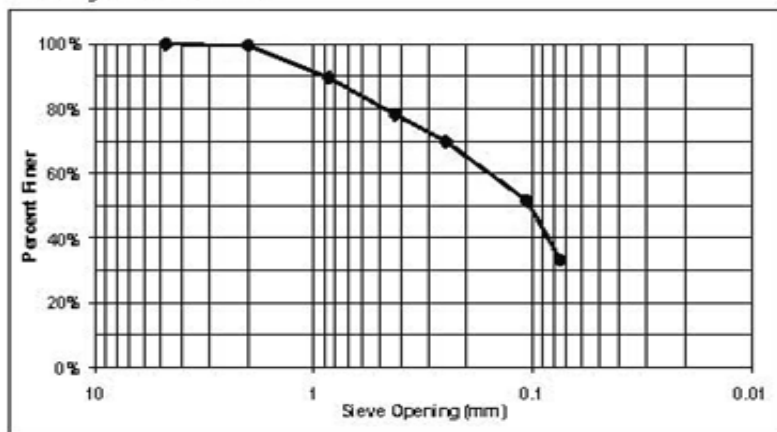

Detailed soils analysis



The University of New Mexico

UNIVERSITY OF NEW MEXICO
DEPARTMENT OF CIVIL ENGINEERING

GRAIN SIZE ANALYSIS

Urban Flood Demonstration Project
Projec

WNN (Bobcat N)
Boring Identification

I. Pedro & C. LaJeune
Tested By

8 13 2
Pan No. Soil Bag No. Sieve Set

November 14, 2006
Date of Testing

Sand with Clay
Field Description of Soil

300.5
Mass of Dry Sample (g), M_s

50 - 54.5
Depth of Sample (m)

Sieve No.	Diameter (mm)	Mass of Sieve (g)	Mass retained (sieve + soil) (g)	% Retained	% Passing
4	4.75	515.7	516.0	0%	100%
10	2	490.7	530.9	13%	87%
20	0.85	412.6	504.9	31%	56%
40	0.425	381.9	437.7	19%	37%
60	0.25	366.8	395.9	10%	26%
140	0.106	342.5	372.0	10%	18%
200	0.075	338.7	347.8	3%	15%
Pan		364.0	408.1	15%	

% Passing = 100 - % Retained

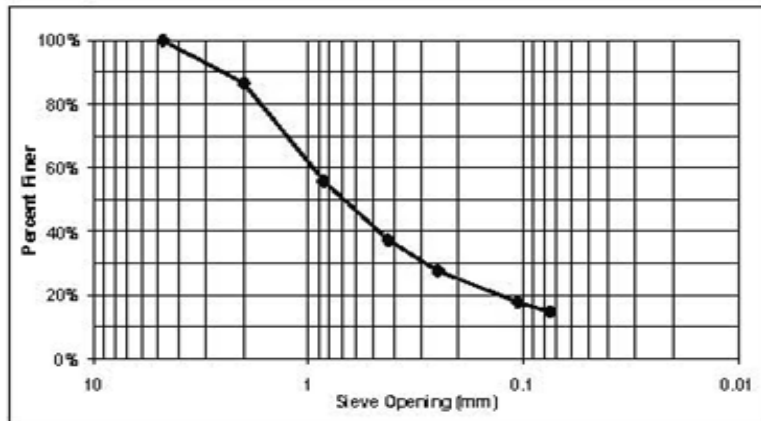

Detailed soils analysis



The University of New Mexico

UNIVERSITY OF NEW MEXICO
DEPARTMENT OF CIVIL ENGINEERING

GRAIN SIZE ANALYSIS

Urban Flood Demonstration Project
Project

WNN (Bobcat N)
Boring Identification

I. Pedro & C. LeJeune
Tested By

9 15 1
Pan No. Soil Bag No. Sieve Set

November 14, 2006
Date of Testing

Gray Sand
Field Description of Soil

341.7
Mass of Dry Sample (g), M

57 - 61
Depth of Sample (n)

Sieve No.	Diameter (mm)	Mass of Sieve (g)	Mass retained (sieve + soil) (g)	% Retained	% Passing
4	4.75	503.2	503.2	0%	100%
10	2	464.4	486.3	6%	94%
20	0.85	413.1	495.2	24%	70%
40	0.425	370.0	430.8	18%	52%
60	0.25	354.0	390.2	11%	41%
140	0.106	342.0	384.4	12%	29%
200	0.075	327.7	349.0	6%	23%
Pan		364.0	441.7	23%	

% Passing = 100 - % Retained

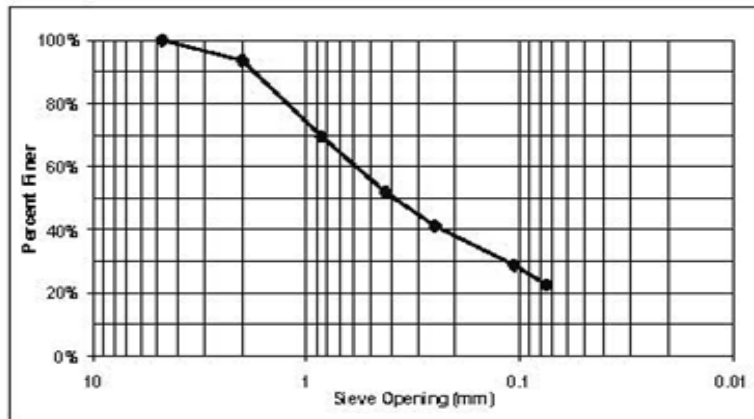

Detailed soils analysis



UNIVERSITY OF NEW MEXICO
DEPARTMENT OF CIVIL ENGINEERING

HYDROMETER ANALYSIS

The University of New Mexico

Project		Issued By		Date	
Urban Flood Demonstration Project		J. Pedro		22-Feb-2007	
Soil Identification	Cylinder #	Depth (ft)	Time		Sample # (LID)
WNN	2	21.5 - 25	10:23 AM		50.0
Specific Gravity	Moisture Content (%)		Notes		
2.70	21.5		Soil Bag 5, Pan 3		

MENISCUS CORRECTION (m)	<u>2</u>
G _s CORRECTION FACTOR (α)	<u>0.99</u>
SUSPENSION CONSTANT (K)	<u>0.01267</u>
CORRECTED SAMPLE WGT. (W _s)	<u>39.3</u>
PERCENT PASSING #200 SIEVE	<u>33%</u>

Elapsed Time (min)	Hydrometer Reading		Temperature (°C)	Effective Depth (cm)		Particle Diameter (mm)	% Finer (%)
	Orig.	R _s		R _{a(Com)}	Corrected		
2	21	19	25	13.2	13.0680	0.0324	15.8%
5	17	15	25	13.8	13.6620	0.0209	12.5%
10	15	13	25	14.2	14.0580	0.0150	10.8%
15	12	10	25	14.7	14.5530	0.0125	8.3%
20	11	9	25	14.8	14.6520	0.0108	7.5%
30	11	9	24	14.8	14.6520	0.0089	7.5%
60	9	7	25	15.2	15.0480	0.0063	5.8%
250	8	6	25	15.3	15.1470	0.0031	5.0%
1440	7	5	25	15.5	15.3450	0.0013	4.2%

Detailed soils analysis



UNIVERSITY OF NEW MEXICO
DEPARTMENT OF CIVIL ENGINEERING

HYDROMETER ANALYSIS

The University of New Mexico

Project Urban Flood Demonstration Project		Tested By J. Pedro		Date 22-Feb-2007
Soil Identification VWNN	Cylinder # 3	Depth (cm) 33 - 36.5	Time 10:33 AM	
Specific Gravity 2.70	Moisture Content (%) 17.1		Notes Soil Bag 8, Pan 5	
Sample Wt. (g) 50.0				

MENISCUS CORRECTION (m)	<u>2</u>
G _s CORRECTION FACTOR (α)	<u>0.99</u>
SUSPENSION CONSTANT (K)	<u>0.01267</u>
CORRECTED SAMPLE WT. (W _s)	<u>41.5</u>
PERCENT PASSING #200 SIEVE	<u>35%</u>

Elapsed Time (min)	Hydrometer Reading		Temperature (°C)	Effective Depth (cm)		Particle Diameter (mm)	% Finer (%)
	Orig.	R _s		R _{s(Corr)}	Corrected		
2	37	35	25	10.6	10.4940	0.0290	29.3%
5	29	27	25	11.9	11.7810	0.0194	22.6%
10	24	22	24	12.7	12.5730	0.0142	18.4%
15	21	19	25	13.2	13.0680	0.0118	15.9%
20	20	18	24	13.3	13.1670	0.0103	15.0%
30	18	16	24	13.7	13.5630	0.0085	13.4%
60	16	14	25	14.0	13.8600	0.0061	11.7%
250	13	11	25	14.5	14.3550	0.0030	9.2%
1440	10	8	25	15.0	14.8500	0.0013	6.7%

Detailed soils analysis



UNIVERSITY OF NEW MEXICO
DEPARTMENT OF CIVIL ENGINEERING

HYDROMETER ANALYSIS

The University of New Mexico

Project Urban Flood Demonstration Project			Prepared By I. Pedra		Date 13 Feb 2007
Boring Identification WNN	Cylinder # 2	Depth (ft) 31 - 33	Time 1:50 PM		Sample Weight 44.6
Specific Gravity 2.70	Moisture Content (%) 21.2		Notes Soil Bag 11, Pan 7		

MENISCUS CORRECTION (m)	<u>3</u>
G _s CORRECTION FACTOR (α)	<u>0.99</u>
SUSPENSION CONSTANT (k)	<u>0.01297</u>
CORRECTED SAMPLE WT. (W _s)	<u>35.1</u>
PERCENT PASSING #200 SIEVE	<u>33%</u>

Elapsed Time (min)	Hydrometer Reading		Temperature (°C)	Effective Depth (cm)		Particle Diameter (mm)	% Finer (%)
	Orig.	R _s		R _{s(Corr)}	Corrected		
2	38	35	23	10.6	10.4940	0.0297	32.5%
5	34	31	23	11.2	11.0880	0.0193	28.8%
10	30	27	23	11.9	11.7810	0.0141	25.1%
15	29	26	23	12.0	11.8800	0.0115	24.2%
20	28	25	23	12.2	12.0780	0.0101	23.2%
30	27	24	23	12.4	12.2760	0.0083	22.3%
60	26	23	23	12.5	12.3750	0.0059	21.4%
250	24	21	23	12.9	12.7710	0.0029	19.5%
1440	19	16	21	13.7	13.5630	0.0013	14.9%

Detailed soils analysis



UNIVERSITY OF NEW MEXICO
DEPARTMENT OF CIVIL ENGINEERING

HYDROMETER ANALYSIS

The University of New Mexico

Project Urban Flood Demonstration Project		Designed by J. Pedro		Date 22-Feb-2007	
Boring Identification VNN	Cylinder # 4	Depth (ft) 57-61	Time 10:46 AM	Sample Weight 80.0	
Specific Gravity 2.70	Moisture Content (%) 39.6	Notes Soil Bag 15, Pan 9			

MENISCUS CORRECTION (m)	<u>2</u>
G _s CORRECTION FACTOR (α)	<u>0.99</u>
SUSPENSION CONSTANT (k)	<u>0.01267</u>
CORRECTED SAMPLE WT. (W _s)	<u>30.2</u>
PERCENT PASSING #200 SIEVE	<u>23%</u>

Elapsed Time (min)	Hydrometer Reading		Temperature (°C)	Effective Depth (cm)		Particle Diameter (mm)	% Finer (%)
	Orig.	R _s		R _{s(Corr)}	Corrected		
2	41	39	25	9.9	9.8010	0.0280	29.4%
5	34	32	25	11.1	10.9890	0.0188	24.1%
10	31	29	25	11.6	11.3850	0.0135	21.9%
15	30	28	25	11.7	11.5830	0.0111	21.1%
20	27	25	24	12.2	12.0780	0.0098	18.8%
30	25	23	25	12.5	12.3750	0.0081	17.3%
60	22	20	25	13.0	12.8700	0.0059	15.1%
250	18	16	25	13.7	13.5630	0.0030	12.1%
1440	15	13	25	14.2	14.0580	0.0013	9.8%

Detailed soils analysis



UNIVERSITY OF NEW MEXICO
DEPARTMENT OF CIVIL ENGINEERING

GRAIN SIZE ANALYSIS

Urban Flood Demonstration Project
Project
I. Pedro
Tested By

WNN (Bobcat N)
Boring Identification
3 5
Pan No. Soil Bag

Sieve No.	Diameter (mm)	% Passing
4	4.75	100%
10	2	100%
20	0.85	89%
40	0.425	72%
60	0.25	62%
140	0.106	46%
200	0.075	33%
	0.0324	15.8%
	0.0209	12.5%
	0.0150	10.8%
	0.0125	8.3%
	0.0108	7.5%
	0.0089	7.5%
	0.0063	5.8%
	0.0031	5.0%
	0.0013	4.2%

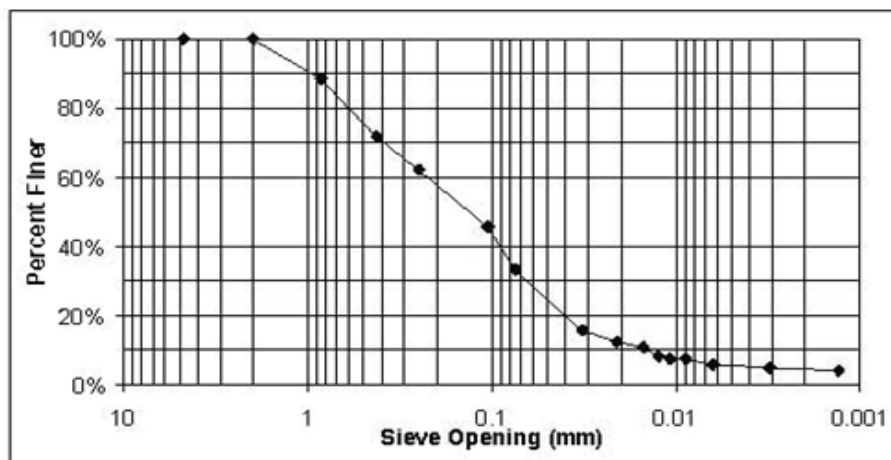

Detailed soils analysis



The University of New Mexico

UNIVERSITY OF NEW MEXICO
DEPARTMENT OF CIVIL ENGINEERING

GRAIN SIZE ANALYSIS

Urban Flood Demonstration Project
Project
I. Pedro
Tested By

WNN (Bobcat N)
Boring Identification
5 8
Pan No. Soil Bag

Sieve No.	Diameter (mm)	% Passing
4	4.75	100%
10	2	93%
20	0.85	80%
40	0.425	73%
60	0.25	68%
140	0.106	53%
200	0.075	35%
	0.0290	29.3%
	0.0194	22.6%
	0.0142	18.4%
	0.0118	15.9%
	0.0103	15.0%
	0.0085	13.4%
	0.0061	11.7%
	0.0030	9.2%
	0.0013	6.7%

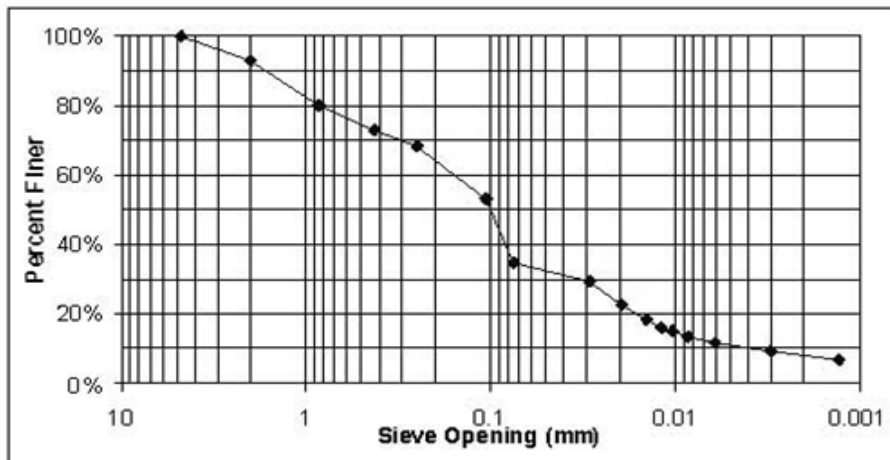

Detailed soils analysis



UNIVERSITY OF NEW MEXICO
DEPARTMENT OF CIVIL ENGINEERING

GRAIN SIZE ANALYSIS

Urban Flood Demonstration Project
Project
I. Pedro
Tested By

WNN (Bobcat N)
Boring Identification
7 11
Pan No. Soil Bag

Sieve No.	Diameter (mm)	% Passing
4	4.75	100%
10	2	100%
20	0.85	89%
40	0.425	78%
60	0.25	70%
140	0.106	51%
200	0.075	33%
	0.0297	32.5%
	0.0193	28.8%
	0.0141	25.1%
	0.0115	24.2%
	0.0101	23.2%
	0.0083	22.3%
	0.0059	21.4%
	0.0029	19.5%
	0.0013	14.9%

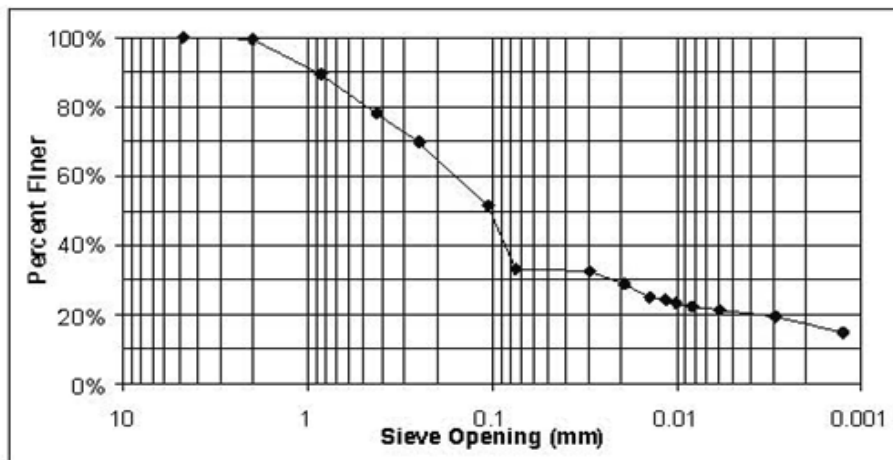

Detailed soils analysis



UNIVERSITY OF NEW MEXICO
DEPARTMENT OF CIVIL ENGINEERING

GRAIN SIZE ANALYSIS

Urban Flood Demonstration Project
Project
I. Pedro
Tested By

WNN (Bobcat N)
Boring Identification
9 15
Pan No. Soil Bag

Sieve No.	Diameter (mm)	% Passing
4	4.75	100%
10	2	94%
20	0.85	70%
40	0.425	52%
60	0.25	41%
140	0.106	29%
200	0.075	23%
	0.0280	29.4%
	0.0188	24.1%
	0.0135	21.9%
	0.0111	21.1%
	0.0098	18.8%
	0.0081	17.3%
	0.0059	15.1%
	0.0030	12.1%
	0.0013	9.8%

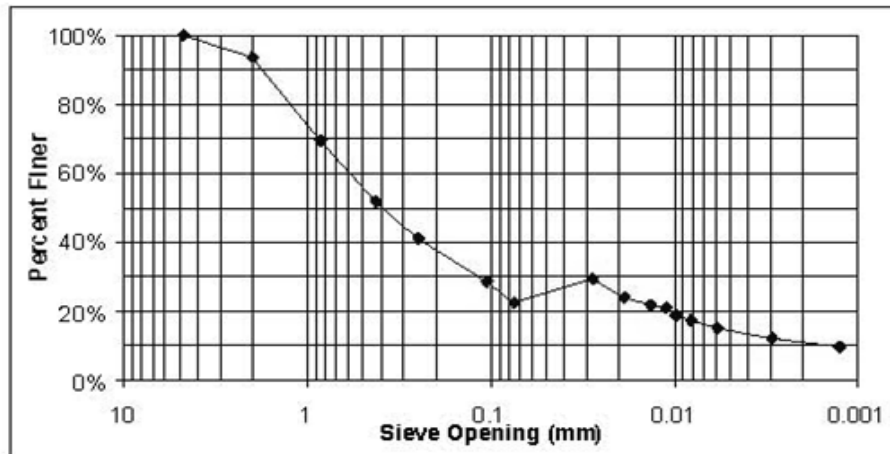

Detailed soils analysis



The University of New Mexico

UNIVERSITY OF NEW MEXICO
DEPARTMENT OF CIVIL ENGINEERING

SOIL BORING LOG INFORMATION

PAGE 1 of 2

Project Name Urban Flood Demonstration Project		Boring Classification ID WNW		Date of Drilling 3-Aug-06		Corresponding Well ID Bobcat (WU22) West		
Boring Drilled By I. Pedro & C. LeJeune		Canopy Rain Gage N/A		Open Rain Gage N/A		Weather Sunny		
Boring Location 4 Feet SW of Well		# of Soil Bags Collected 19		Meterable Depth 74"		Final Depth 74.5"		
				Well Bearer Depth 74"		Temperature N/A		
DEPTH (IN)	SAMPLE NUMBER	DESCRIPTION (Visual-Manual Method)						COMMENTS
		MOISTURE	COLOR	DRY STRENGTH	DILATANCY	TOUGHNESS	PLASTICITY	
0	0	M	DBm					Area covered with clearing mulch. Bagged mulch then proceeded
1	1	M	DBm	H	S	S	L	Change in color with a more clayey appearance
7.5	2	M	Bm	VH	S	S	L	↓
10.5	3	M	Bm	H	N	N	L	Sandy appearance
12.5	4	M	Bm	M	S	S	L	↓
18	5	M	Bm	M	S	L	N	↓
23	6	M	LBm	L	S	L	N	↓
27.5	7	M	LBm	L	S	L	N	Encountered some roots
30	8	M	LBm	M	S	L	L	↓
33	9	M	Bm	VH	S	L	L	Brown & clumpy with a more clayey appearance
35	10	M	Bm	H	N	H	M	↓
39	11	M	RBm	VH	N	H	M	Reddish brown & clumpy appearance
43.5	12	VM	RBm	VH	N	H	M	↓
47	13	VM	RBm	L	S	M	M	↓
49	14	VM	OBm	L	R	L	L	Color change, more sandy appearance
55	15	VM	OBm	L	N	L	N	Bottom of sample has black strip of organic material
61	16	VM	OBm	L	R	L	L	↓
63	17	VM	OBm	L	R	L	L	↓
<p>I hereby certify that the information of this form is true and correct to the best of my knowledge</p>								
Signature				Print Name		Date		
				Isaiah Pedro / Chnstian LeJeune		3-Aug-06		

Detailed soils analysis



The University of New Mexico

UNIVERSITY OF NEW MEXICO
DEPARTMENT OF CIVIL ENGINEERING

WATER CONTENT DETERMINATION

Urban Flood Demonstration Project
Project

J. Pedro & C. Lejeune
Tested By

November 8, 2006
Date of Testing

November 9, 2006
Date of Dry Weighing

WNW (Bobcat W)
Boring Identification

CONTAINER NO. (CUP)	1	2	3	4	5	6	7
FIELD TEXTURE	OM	Sand w/Clay	Sand w/Clay	L. Brown Sand	L. Brown Sand	Sand w/Clay	Sand w/Clay
BORING BAG NO.	1	2	3	5	7	9	11
DEPTH (ft)	0 - 1	1 - 7.5	7.5 - 10.5	12.5 - 18	23 - 27.5	30 - 33	35 - 39
MASS OF CUP + WET SOIL (g)	216.8	601.7	505.3	527.5	660.0	340.7	612.6
MASS OF CUP + DRY SOIL (g)	200.7	512.0	447.5	493.5	630.6	301.7	517.8
MASS OF CUP (g)	139.2	138.6	139.1	139.2	138.9	139.0	137.8
MASS OF DRY SOIL, Ms (g)	61.5	373.4	308.4	354.3	491.7	162.7	380.0
MASS OF WATER, Mw (g)	16.1	89.7	57.8	34.0	29.4	39.0	94.8
WATER CONTENT, w (%)	26.2%	24.0%	18.7%	9.6%	6.0%	24.0%	24.9%

CONTAINER NO. (CUP)	8	9	10	11			
FIELD TEXTURE	Sand w/Clay	O. Sand	O. Sand	Gray Sand			
BORING BAG NO.	13	14	17	18			
DEPTH (ft)	43.5 - 47	47 - 49	61 - 63	63 - 67.5			
MASS OF CUP + WET SOIL (g)	619.0	258.2	297.0	773.0			
MASS OF CUP + DRY SOIL (g)	555.8	248.7	270.8	632.5			
MASS OF CUP (g)	138.0	139.4	139.4	137.6			
MASS OF DRY SOIL, Ms (g)	417.8	109.3	131.4	494.9			
MASS OF WATER, Mw (g)	63.2	9.5	26.2	140.5			
WATER CONTENT, w (%)	15.1%	8.7%	19.9%	28.4%			

$$w = \frac{M_w}{M_s} (100) \%$$

Detailed soils analysis



UNIVERSITY OF NEW MEXICO
DEPARTMENT OF CIVIL ENGINEERING

GRAIN SIZE ANALYSIS

Urban Flood Demonstration Project
Project

WNW (Bobcat W)
Boring Identification

C. LeJeune & I. Pedro
Tested By

1 1 1
Pan No. Soil Bag No. Sieve Set

November 9, 2006
Date of Testing

OM
Field Description of Soil

61.5
Mass of Dry Sample (g), M

0 - 1
Depth of Sample (in)

Sieve No.	Diameter (mm)	Mass of Sieve (g)	Mass retained (sieve + soil) (g)	% Retained	% Passing
4	4.75	503.2	503.4	0%	100%
10	2	464.4	465.8	2%	97%
20	0.85	413.1	430.2	28%	70%
40	0.425	370.0	380.9	18%	52%
60	0.25	354.0	360.5	11%	41%
140	0.106	342.0	351.7	16%	26%
200	0.075	327.7	333.2	9%	17%
Pan		364.0	375.0	17%	

% Passing = 100 - % Retained



Detailed soils analysis



UNIVERSITY OF NEW MEXICO
DEPARTMENT OF CIVIL ENGINEERING

GRAIN SIZE ANALYSIS

Urban Flood Demonstration Project
Project

WNW (Bobcat W)
Boring Identification

C. LeJeune & I. Pedro
Tested By

2 2 2
Pan No. Soil Bag No. Sieve Set

November 9, 2006
Date of Testing

Sand with Clay
Field Description of Soil

373.4
Mass of Dry Sample (g), M

1 - 7.5
Depth of Sample

Sieve No.	Diameter (mm)	Mass of Sieve (g)	Mass retained (sieve + soil) (g)	% Retained	% Passing
4	4.75	515.7	515.8	0%	100%
10	2	490.7	490.8	0%	100%
20	0.85	412.6	462.7	13%	87%
40	0.425	381.9	453.0	19%	67%
60	0.25	366.8	408.5	11%	56%
140	0.106	342.5	404.7	17%	40%
200	0.075	338.7	378.5	11%	29%
Pan		364.0	472.1	29%	

% Passing = 100 - % Retained

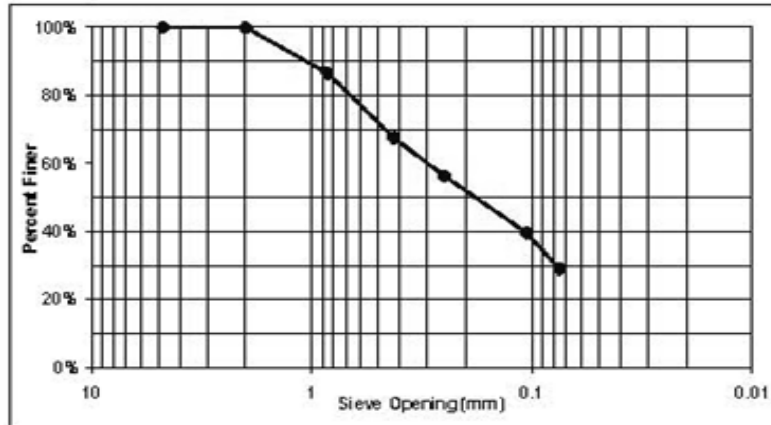

Detailed soils analysis



UNIVERSITY OF NEW MEXICO
DEPARTMENT OF CIVIL ENGINEERING

GRAIN SIZE ANALYSIS

Urban Flood Demonstration Project
Project

WNW (Bobcat W)
Boring Identification

C. LeJeune & I. Pedro
Tested By

3 3 1
Pan No. Soil Bag No. Sieve Set

November 9, 2006
Date of Testing

Sand with Clay
Field Description of Soil

308.4
Mass of Dry Sample (g), M_s

7.5 - 10.5
Depth of Sample (m)

Sieve No.	Diameter (mm)	Mass of Sieve (g)	Mass retained (sieve + soil) (g)	% Retained	% Passing
4	4.75	503.2	503.2	0%	100%
10	2	464.4	464.5	0%	100%
20	0.85	413.1	459.4	15%	85%
40	0.425	370.0	421.6	17%	68%
60	0.25	354.0	381.8	9%	59%
140	0.106	342.0	398.1	18%	41%
200	0.075	327.7	368.9	13%	28%
Pan		364.0	450.5	28%	

% Passing = 100 - % Retained

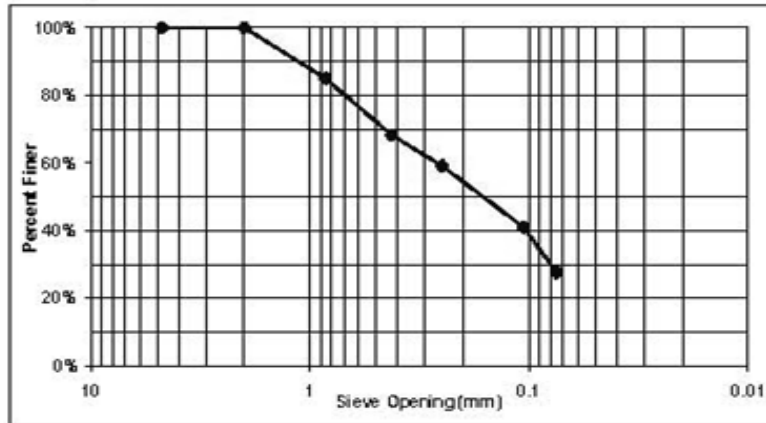

Detailed soils analysis



The University of New Mexico

UNIVERSITY OF NEW MEXICO
DEPARTMENT OF CIVIL ENGINEERING

GRAIN SIZE ANALYSIS

Urban Flood Demonstration Project
Project

WNW (Bobcat W)
Boring Identification

C. LeJeune & I. Pedro
Tested By

4 Pan No. 5 Soil Bag No. 2 Sieve Set

November 9, 2006
Date of Testing

Light Brown Sand
Field Description of Soil

354.3
Mass of Dry Sample (g), M

12.5 - 18
Depth of Sample (n)

Sieve No.	Diameter (mm)	Mass of Sieve (g)	Mass retained (sieve + soil) (g)	% Retained	% Passing
4	4.75	515.7	515.8	0%	100%
10	2	490.7	490.8	0%	100%
20	0.85	412.6	417.9	1%	98%
40	0.425	381.9	392.6	3%	95%
60	0.25	366.8	378.0	3%	92%
140	0.106	342.5	462.6	34%	58%
200	0.075	338.7	424.3	24%	34%
Pan		364.0	486.8	34%	

% Passing = 100 - % Retained

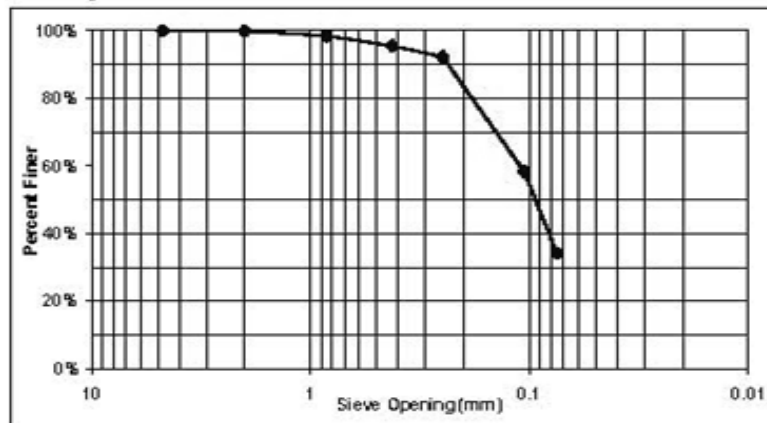

Detailed soils analysis



UNIVERSITY OF NEW MEXICO
DEPARTMENT OF CIVIL ENGINEERING

GRAIN SIZE ANALYSIS

Urban Flood Demonstration Project
Projec

WNW (Bobcat W)
Boring Identification

C. LaJeune & I. Pedro
Tested By

5 7 1
Pan No. Soil Bag No. Sieve Set

November 9, 2006
Date of Testing

Light Brown Sand
Field Description of Soil

491.7
Mass of Dry Sample (g), M

23 - 27.5
Depth of Sample (m)

Sieve No.	Diameter (mm)	Mass of Sieve (g)	Mass retained (sieve + soil) (g)	% Retained	% Passing
4	4.75	503.2	504.2	0%	100%
10	2	464.4	470.4	1%	99%
20	0.85	413.1	422.2	2%	97%
40	0.425	370.0	374.8	1%	96%
60	0.25	354.0	358.7	1%	95%
140	0.106	342.0	432.6	18%	76%
200	0.075	327.7	458.9	27%	50%
Pan		364.0	611.8	50%	

% Passing = 100 - % Retained

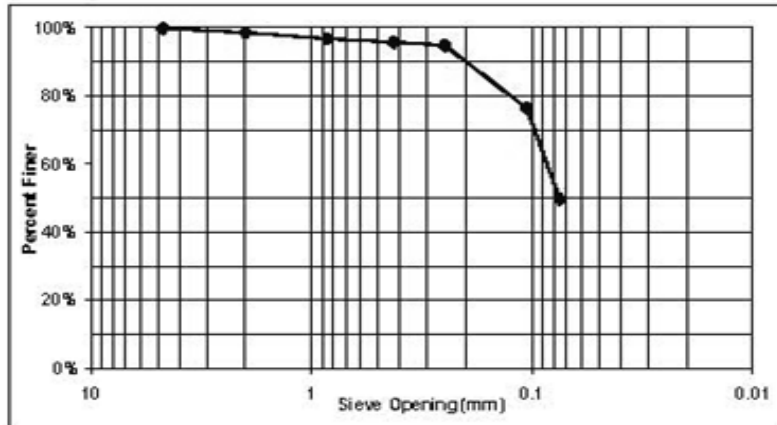

Detailed soils analysis



UNIVERSITY OF NEW MEXICO
DEPARTMENT OF CIVIL ENGINEERING

GRAIN SIZE ANALYSIS

Urban Flood Demonstration Project
Project

WNW (Bobcat W)
Boring Identification

C. LaJeune & I. Pedro
Tested By

6 9 2
Pan No. Soil Bag No. Sieve Set

November 9, 2006
Date of Testing

Sand with Clay
Field Description of Soil

162.7
Mass of Dry Sample (g), M

30 - 33
Depth of Sample

Sieve No.	Diameter (mm)	Mass of Sieve (g)	Mass retained (sieve + soil) (g)	% Retained	% Passing
4	4.75	515.7	515.8	0%	100%
10	2	490.7	500.3	6%	94%
20	0.85	412.6	449.9	23%	71%
40	0.425	381.9	413.5	19%	52%
60	0.25	366.8	384.5	11%	41%
140	0.106	342.5	360.4	11%	30%
200	0.075	338.7	344.7	4%	26%
Pan		364.0	408.8	26%	

% Passing = 100 - % Retained

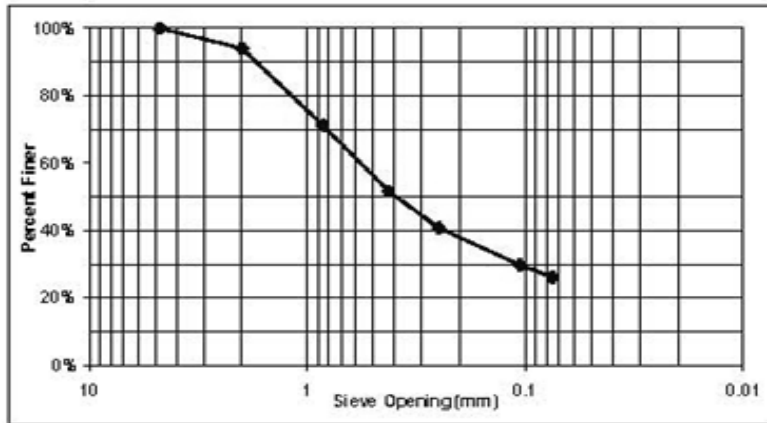

Detailed soils analysis



UNIVERSITY OF NEW MEXICO
DEPARTMENT OF CIVIL ENGINEERING

GRAIN SIZE ANALYSIS

Urban Flood Demonstration Project
Project

WNW (Bobcat W)
Boring Identification

C. LeJeune & I. Pedro
Tested By

7 Pan No. 11 Soil Bag No. 1 Sieve Set

November 9, 2006
Date of Testing

Sand with Clay
Field Description of Soil

380
Mass of Dry Sample (g), M

35 - 39
Depth of Sample (m)

Sieve No.	Diameter (mm)	Mass of Sieve (g)	Mass retained (sieve + soil) (g)	% Retained	% Passing
4	4.75	503.2	504.7	0%	100%
10	2	464.4	490.4	7%	93%
20	0.85	413.1	536.8	33%	60%
40	0.425	370.0	443.9	19%	41%
60	0.25	354.0	398.4	12%	29%
140	0.106	342.0	399.0	15%	14%
200	0.075	327.7	343.7	4%	10%
Pan		364.0	404.9	10%	

% Passing = 100 - % Retained



Detailed soils analysis



UNIVERSITY OF NEW MEXICO
DEPARTMENT OF CIVIL ENGINEERING

GRAIN SIZE ANALYSIS

Urban Flood Demonstration Project
Project

WNW (Bobcat W)
Boring Identification

I. Pedro & C. LeJeune
Tested By

8 Pan No. 13 Soil Bag No. 2 Sieve Set

November 9, 2006
Date of Testing

Sand with Clay
Field Description of Soil

417.8
Mass of Dry Sample (g), M_s

43.5 - 47
Depth of Sample (ft)

Sieve No.	Diameter (mm)	Mass of Sieve (g)	Mass retained (sieve + soil) (g)	% Retained	% Passing
4	4.75	515.7	515.8	0%	100%
10	2	490.7	492.7	0%	99%
20	0.85	412.6	431.2	4%	95%
40	0.425	381.9	425.9	11%	85%
60	0.25	366.8	449.7	20%	65%
140	0.106	342.5	495.4	37%	28%
200	0.075	338.7	390.4	12%	16%
Pan		364.0	430.8	16%	

% Passing = 100 - % Retained

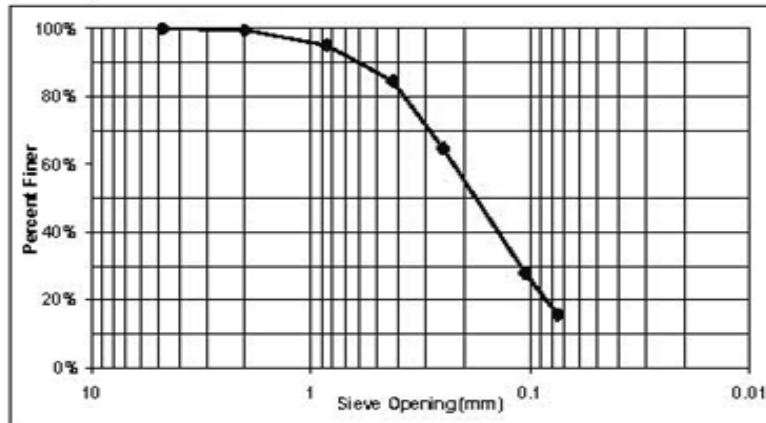

Detailed soils analysis



UNIVERSITY OF NEW MEXICO
DEPARTMENT OF CIVIL ENGINEERING

GRAIN SIZE ANALYSIS

Urban Flood Demonstration Project
Projec

WNW (Bobcat W)
Boring Identification

C. LeJeune & I. Pedro
Tested By

9 14 1
Pan No. Soil Bag No. Sieve Set

November 9, 2006
Date of Testing

Orange Sand
Field Description of Soil

109.3
Mass of Dry Sample (g), M

47 - 49
Depth of Sample (in)

Sieve No.	Diameter (mm)	Mass of Sieve (g)	Mass retained (sieve + soil) (g)	% Retained	% Passing
4	4.75	503.2	503.3	0%	100%
10	2	464.4	464.5	0%	100%
20	0.85	413.1	416.6	3%	97%
40	0.425	370.0	379.0	8%	88%
60	0.25	354.0	389.7	33%	56%
140	0.106	342.0	396.8	50%	6%
200	0.075	327.7	332.2	4%	1%
Pan		364.0	366.6	1%	

% Passing = 100 - % Retained



Detailed soils analysis



UNIVERSITY OF NEW MEXICO
DEPARTMENT OF CIVIL ENGINEERING

GRAIN SIZE ANALYSIS

The University of New Mexico

Urban Flood Demonstration Project
Project

WNW (Bobcat W)
Boring Identification

C. LeJeune & I. Pedro
Tested By

10 17 2
Pan No. Soil Bag No. Sieve Set

November 9, 2006
Date of Testing

Orange Sand
Field Description of Soil

131.4
Mass of Dry Sample (g), M

61 - 63
Depth of Sample (in)

Sieve No.	Diameter (mm)	Mass of Sieve (g)	Mass retained (sieve + soil) (g)	% Retained	% Passing
4	4.75	515.7	515.8	0%	100%
10	2	490.7	492.2	1%	99%
20	0.85	412.6	420.9	6%	92%
40	0.425	381.9	389.9	6%	86%
60	0.25	366.8	387.0	15%	71%
140	0.106	342.5	411.2	52%	19%
200	0.075	338.7	350.6	9%	10%
Pan		364.0	376.9	10%	

% Passing = 100 - % Retained

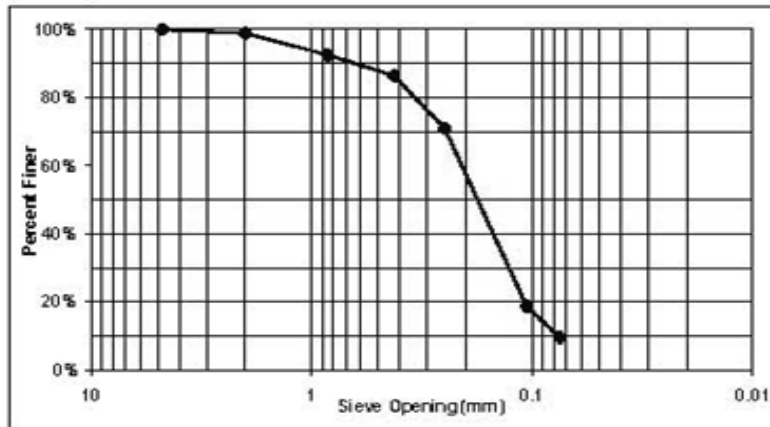

Detailed soils analysis



UNIVERSITY OF NEW MEXICO
DEPARTMENT OF CIVIL ENGINEERING

GRAIN SIZE ANALYSIS

The University of New Mexico

Urban Flood Demonstration Project
Projec

WNW (Bobcat W)
Boring Identification

I. Pedro & C. LaJeune
Tested By

11 18 1
Pan No. Soil Bag No. Sieve Set

November 9, 2006
Date of Testing

Gray Sand
Field Description of Soil

494.9
Mass of Dry Sample (g), M

63 - 67.5
Depth of Sample (m)

Sieve No.	Diameter (mm)	Mass of Sieve (g)	Mass retained (sieve + soil) (g)	% Retained	% Passing
4	4.75	503.2	503.2	0%	100%
10	2	464.4	464.8	0%	100%
20	0.85	413.1	436.0	5%	95%
40	0.425	370.0	405.2	7%	88%
60	0.25	354.0	398.8	9%	79%
140	0.106	342.0	530.1	38%	41%
200	0.075	327.7	393.8	13%	28%
Pan		364.0	505.0	28%	

% Passing = 100 - % Retained

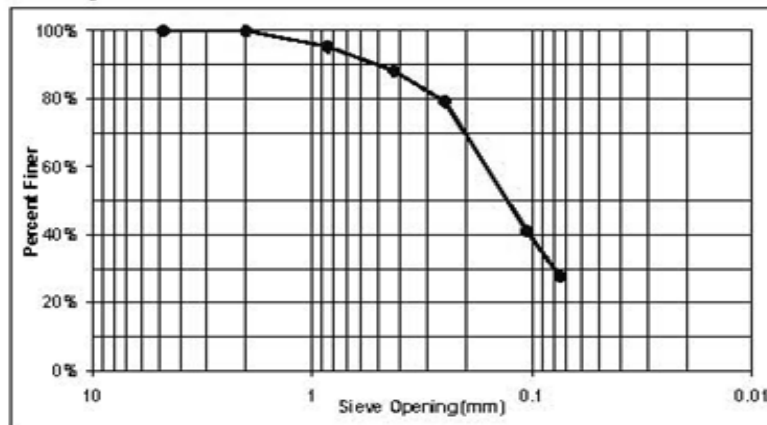

Detailed soils analysis



UNIVERSITY OF NEWMEXICO
DEPARTMENT OF CIVIL ENGINEERING

HYDROMETER ANALYSIS

The University of New Mexico

Project Urban Flood Demonstration Project		Analyzed By J. Pedro		Date 20-Feb-2007
Soing Identification VWNV	Cylinder # 5	Depth (cm) 12.5 - 18	Time 12:10 PM	Sample Wt (g) 50.0
Specific Gravity 2.70	Mixture Correction (C) 9.6	Notes Soil Bag 5, Pan 4		

MENISCUS CORRECTION (m)	<u>2</u>
G _s CORRECTION FACTOR (α)	<u>0.99</u>
SUSPENSION CONSTANT (k)	<u>0.01312</u>
CORRECTED SAMPLE WT, (W _s)	<u>45.2</u>
PERCENT PASSING #200 SIEVE	<u>34%</u>

Elapsed Time (min)	Hydrometer Reading		Temperature (°C)	Effective Depth (cm)		Particle Diameter (mm)	% Finer (%)
	Orig.	R _s		R _{a(Corr)}	Corrected		
2	12	10	23	14.7	14.5530	0.0354	7.4%
5	8	6	22	15.3	15.1470	0.0228	4.5%
10	7	5	22	15.5	15.3450	0.0163	3.7%
15	7	5	22	15.5	15.3450	0.0133	3.7%
20	5	3	23	15.8	15.6420	0.0116	2.2%
30	5	3	22	15.8	15.6420	0.0095	2.2%
60	5	3	22	15.8	15.6420	0.0067	2.2%
250	4	2	22	16.0	15.8400	0.0033	1.5%
1440	4	2	22	16.0	15.8400	0.0014	1.5%

Detailed soils analysis



UNIVERSITY OF NEW MEXICO
DEPARTMENT OF CIVIL ENGINEERING

HYDROMETER ANALYSIS

The University of New Mexico

Project Urban Flood Demonstration Project		Issued By J. Pedro		Date 20-Feb-2007
Boring Identification VVNVV	Cylinder # 6	Depth (m) 23 - 27.5	Time 12:30 PM	Sample Wt. (g) 50.0
Specific Gravity 2.70	Molecular Weight (M) 6.0	Notes Soil Bag 7, Pan 5		

MENISCUS CORRECTION (m)	<u>-2</u>
G _s CORRECTION FACTOR (α)	<u>0.99</u>
SUSPENSION CONSTANT (k)	<u>0.01312</u>
CORRECTED SAMPLE Wt. (W _s)	<u>47.0</u>
PERCENT PASSING #200 SIEVE	<u>50%</u>

Elapsed Time (min)	Hydrometer Reading		Temperature (°C)	Effective Depth (cm)		Particle Diameter (mm)	% Finer (%)
	Orig.	R _s		R _{s(Corr)}	Corrected		
2	11	9	23	14.8	14.6520	0.0355	9.5%
5	8	6	22	15.3	15.1470	0.0228	6.3%
10	6	4	22	15.6	15.4440	0.0163	4.2%
15	6	4	22	15.6	15.4440	0.0133	4.2%
20	6	4	22	15.6	15.4440	0.0115	4.2%
30	6	4	23	15.6	15.4440	0.0094	4.2%
60	5	3	23	15.8	15.6420	0.0067	3.2%
250	4	2	23	16.0	15.8400	0.0033	2.1%
1440	3	1	22	16.1	15.9390	0.0014	1.1%

Detailed soils analysis



UNIVERSITY OF NEW MEXICO
DEPARTMENT OF CIVIL ENGINEERING

GRAIN SIZE ANALYSIS

The University of New Mexico

Urban Flood Demonstration Project
Project
I. Pedro
Tested By

WNW (Bobcat W)
Boring Identification
4 5
Pan No. Soil Bag

Sieve No.	Diameter (mm)	% Passing
4	4.75	100%
10	2	100%
20	0.85	98%
40	0.425	95%
60	0.25	92%
140	0.106	58%
200	0.075	34%
	0.0354	7.4%
	0.0228	4.5%
	0.0163	3.7%
	0.0133	3.7%
	0.0116	2.2%
	0.0095	2.2%
	0.0067	2.2%
	0.0033	1.5%
	0.0014	1.5%

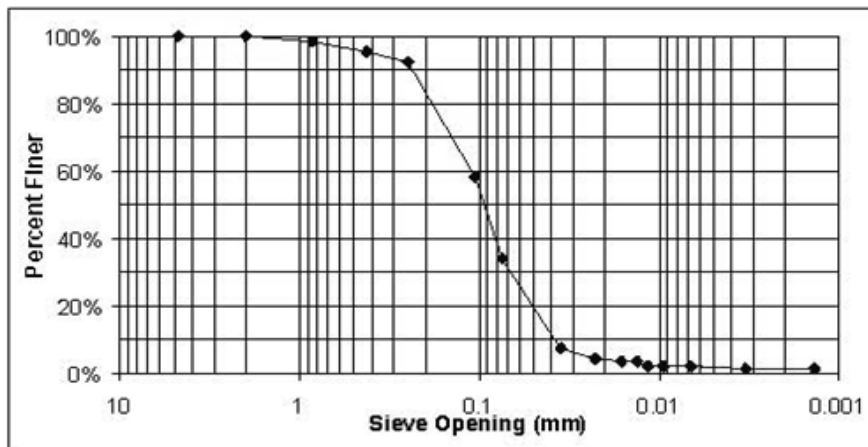

Detailed soils analysis



UNIVERSITY OF NEW MEXICO
DEPARTMENT OF CIVIL ENGINEERING

GRAIN SIZE ANALYSIS

The University of New Mexico

Urban Flood Demonstration Project
Project
I. Pedro
Tested By

WNW (Bobcat W)
Boring Identification
5 7
Pan No. Soil Bag

Sieve No.	Diameter (mm)	% Passing
4	4.75	100%
10	2	99%
20	0.85	97%
40	0.425	96%
60	0.25	95%
140	0.106	76%
200	0.075	50%
	0.0355	9.5%
	0.0228	6.3%
	0.0163	4.2%
	0.0133	4.2%
	0.0115	4.2%
	0.0094	4.2%
	0.0067	3.2%
	0.0033	2.1%
	0.0014	1.1%

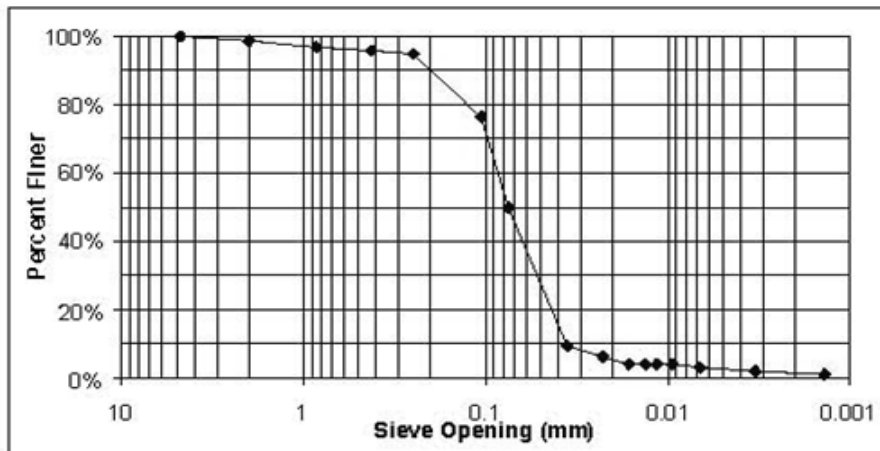

Detailed soils analysis



UNIVERSITY OF NEW MEXICO
DEPARTMENT OF CIVIL ENGINEERING

SOIL BORING LOG INFORMATION

PAGE 1 of 1

The University of New Mexico

Project Name Urban Flood Demonstration Project		Boring Classification ID WNS		Date of Drilling 8-Aug-06		Corresponding Well ID Bobcat (WU22) South		
Boring Drilled By: I. Pedro & C. LeJeune		Canopy Rain Gage N/A		Open Rain Gage N/A		Weather Sunny and Partly Cloudy		
Boring Location 3 Feet SW of Well		# of Soil Bags Collected 11		Water Table Depth 53"		Final Depth 62"		
				Well Ejector Depth 46"		Temperature 86 F		
DEPTH (IN)	SAMPLE NUMBER	DESCRIPTION (Visual-Manual Method)						COMMENTS
		MOISTURE	COLOR	DRY STRENGTH	DILATANCY	TOUGHNESS	PLASTICITY	
0	0							Vegetation growing, twigs, leaves and organic material present.
8	1	M	DBm	H	S	M	M	Organic material present, encountered roots
12.5	2	M	Bm	M	N	H	H	
19	3	VM	Bm	M	S	M	M	Sandy appearance
24.5	4	VM	Bm	H	S	L	L	Sandy clay appearance. Clay smell with organic material present.
29.5	5	VM	Bm	H	S	M	M	
34.5	6	VM	Brn	M	S	H	H	More clayish appearance
38	7	VM	Bm	L	S	M	M	
41.5	8	VM	Gr	M	S	M	H	Grey clayish appearance and smell.
50	9	VM	Gr	M	S	M	M	
58	10	W	Gr					Water table reached @ 53". Too saturated for VMM testing
62	11	W	Gr					Bed Sand appearance
I hereby certify that the information of this form is true and correct to the best of my knowledge								
Signature				Print Name		Date		
				Isaiah Pedro / Chnstian LeJeune		8-Aug-06		

Detailed soils analysis



UNIVERSITY OF NEW MEXICO
DEPARTMENT OF CIVIL ENGINEERING

WATER CONTENT DETERMINATION

The University of New Mexico

Urban Flood Demonstration Project
Project

J. Pedro & C. LeJeune
Tested By

November 9, 2006
Date of Testing

November 10, 2006
Date of Dry Weighing

WNS (Bobcat S)
Boring Identification

CONTAINER NO. (CUP)	1	2	3	4	5	6	
FIELD TEXTURE	DM	Brown Sand	Sand w/Clay	Sand w/Clay	Gray Sand	Gray Sand	
BORING BAG NO.	1	3	4	7	8	10	
DEPTH (in)	0 - 8	12.5 - 19	19 - 24.5	34.5 - 38	38 - 41.5	50 - 58	
MASS OF CUP + WET SOIL (g)	667.2	869.5	742.1	561.0	462.2	765.5	
MASS OF CUP + DRY SOIL (g)	532.7	732.2	609.4	464.5	382.4	586.1	
MASS OF CUP (g)	139.2	138.6	139.1	139.2	138.9	139.0	
MASS OF DRY SOIL, Ms (g)	393.5	593.6	470.3	325.3	243.5	447.1	
MASS OF WATER, Mw (g)	134.5	137.3	132.7	96.5	79.8	179.4	
WATER CONTENT, w (%)	34.2%	23.1%	28.2%	29.7%	32.8%	40.1%	

CONTAINER NO. (CUP)							
FIELD TEXTURE							
BORING BAG NO.							
DEPTH (in)							
MASS OF CUP + WET SOIL (g)							
MASS OF CUP + DRY SOIL (g)							
MASS OF CUP (g)							
MASS OF DRY SOIL, Ms (g)							
MASS OF WATER, Mw (g)							
WATER CONTENT, w (%)							

$$w = \frac{M_w}{M_s} (100) \%$$

Detailed soils analysis



UNIVERSITY OF NEW MEXICO
DEPARTMENT OF CIVIL ENGINEERING

GRAIN SIZE ANALYSIS

Urban Flood Demonstration Project
Project

WNS (Bobcat S)
Boring Identification

I. Pedro
Tested By

1 1 1
Pan No. Soil Bag No. Sieve Set

November 10, 2006
Date of Testing

OM
Field Description of Soil

393.5
Mass of Dry Sample (g), M

0 - 8
Depth of Sample (m)

Sieve No.	Diameter (mm)	Mass of Sieve (g)	Mass retained (sieve + soil) (g)	% Retained	% Passing
4	4.75	503.2	503.3	0%	100%
10	2	464.4	465.8	0%	100%
20	0.85	413.1	459.0	12%	88%
40	0.425	370.0	434.8	16%	71%
60	0.25	354.0	401.4	12%	59%
140	0.106	342.0	452.1	28%	31%
200	0.075	327.7	374.7	12%	20%
Pan		364.0	439.4	20%	

% Passing = 100 - % Retained



Detailed soils analysis



UNIVERSITY OF NEW MEXICO
DEPARTMENT OF CIVIL ENGINEERING

GRAIN SIZE ANALYSIS

Urban Flood Demonstration Project
Project

WNS (Bobcat S)
Boring Identification

I. Pedro
Tested By

2 3 2
Pan No. Soil Bag No. Sieve Set

November 10, 2006
Date of Testing

Brown Sand
Field Description of Soil

593.6
Mass of Dry Sample (g), M

12.5 - 19
Depth of Sample (m)

Sieve No.	Diameter (mm)	Mass of Sieve (g)	Mass retained (sieve + soil) (g)	% Retained	% Passing
4	4.75	515.7	517.4	0%	100%
10	2	490.7	491.5	0%	100%
20	0.85	412.6	445.8	6%	94%
40	0.425	381.9	443.8	10%	84%
60	0.25	366.8	416.9	8%	75%
140	0.106	342.5	520.1	30%	45%
200	0.075	338.7	430.4	15%	30%
Pan		364.0	539.5	30%	

% Passing = 100 - % Retained

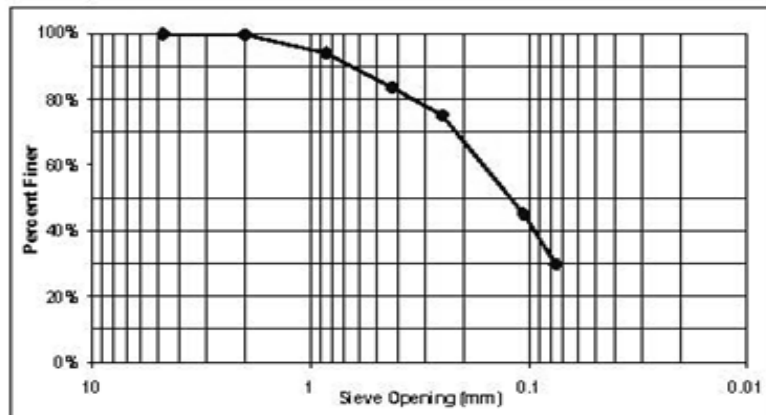

Detailed soils analysis



UNIVERSITY OF NEW MEXICO
DEPARTMENT OF CIVIL ENGINEERING

GRAIN SIZE ANALYSIS

Urban Flood Demonstration Project
Projec

WNS (Bobcat S)
Boring Identification

I. Pedro
Tested By

3 4 1
Pan No. Soil Bag No. Sieve Set

November 10, 2006
Date of Testing

Sand with Clay
Field Description of Soil

470.3
Mass of Dry Sample (g), M

19 - 245
Depth of Sample (in)

Sieve No.	Diameter (mm)	Mass of Sieve (g)	Mass retained (sieve + soil) (g)	% Retained	% Passing
4	4.75	503.2	503.5	0%	100%
10	2	464.4	476.2	3%	97%
20	0.85	413.1	531.5	25%	72%
40	0.425	370.0	447.9	17%	56%
60	0.25	354.0	390.5	8%	48%
140	0.106	342.0	397.3	12%	36%
200	0.075	327.7	369.0	9%	27%
Pan		364.0	492.1	27%	

% Passing = 100 - % Retained

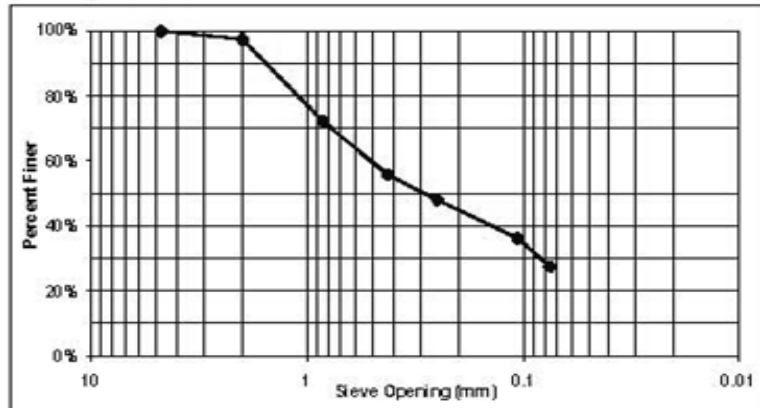

Detailed soils analysis



UNIVERSITY OF NEW MEXICO
DEPARTMENT OF CIVIL ENGINEERING

GRAIN SIZE ANALYSIS

Urban Flood Demonstration Project
Project

WNS (Bobcat S)
Boring Identification

L. Pedro
Tested By

4 7 2
Pan No. Soil Bag No. Sieve Set

November 10, 2006
Date of Testing

Sand with Clay
Field Description of Soil

325.3
Mass of Dry Sample (g), M

345 - 38
Depth of Sample (n)

Sieve No.	Diameter (mm)	Mass of Sieve (g)	Mass retained (sieve + soil) (g)	% Retained	% Passing
4	4.75	515.7	515.7	0%	100%
10	2	490.7	490.8	0%	100%
20	0.85	412.6	439.9	8%	92%
40	0.425	381.9	418.7	11%	80%
60	0.25	366.8	388.7	7%	74%
140	0.106	342.5	397.2	17%	57%
200	0.075	338.7	379.6	13%	44%
Pan		364.0	507.8	44%	

% Passing = 100 - % Retained

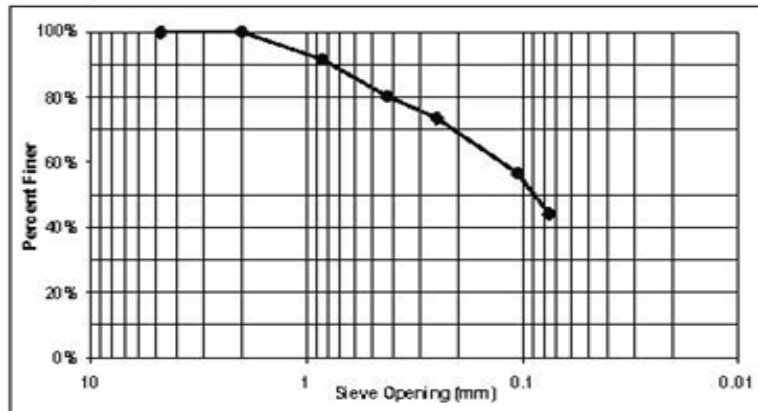

Detailed soils analysis



The University of New Mexico

UNIVERSITY OF NEW MEXICO
DEPARTMENT OF CIVIL ENGINEERING

GRAIN SIZE ANALYSIS

Urban Flood Demonstration Project
Projec

WNS (Bobcat S)
Boring Identification

I. Pedro
Tested By

5 8 1
Pan No. Soil Bag No. Sieve Set

November 10, 2006
Date of Testing

Gray Sand
Field Description of Soil

243.5
Mass of Dry Sample (g), M_s

38 - 41.5
Depth of Sample (in)

Sieve No.	Diameter (mm)	Mass of Sieve (g)	Mass retained (sieve + soil) (g)	% Retained	% Passing
4	4.75	503.2	503.2	0%	100%
10	2	464.4	464.6	0%	100%
20	0.85	413.1	440.9	11%	89%
40	0.425	370.0	400.3	12%	76%
60	0.25	354.0	370.9	7%	69%
140	0.106	342.0	371.9	12%	57%
200	0.075	327.7	356.6	12%	45%
Pan		364.0	475.6	45%	

% Passing = 100 - Σ% Retained

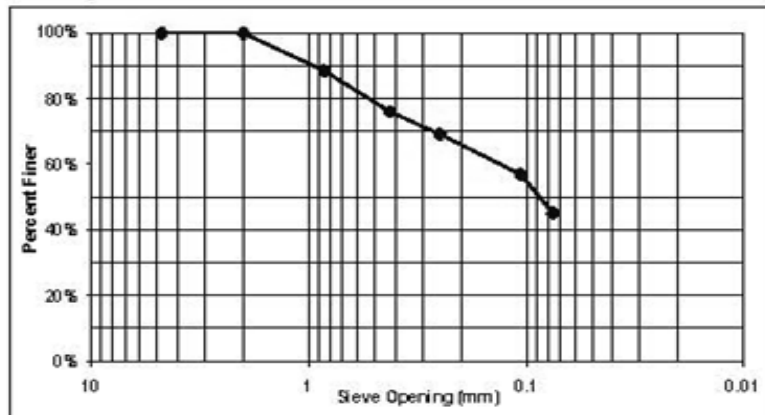

Detailed soils analysis



The University of New Mexico

UNIVERSITY OF NEW MEXICO
DEPARTMENT OF CIVIL ENGINEERING

GRAIN SIZE ANALYSIS

Urban Flood Demonstration Project
Project

WNS (Bobcat S)
Boring Identification

L. Pedro
Tested By

6 10 2
Pan No. Soil Bag No. Sieve Set

November 10, 2006
Date of Testing

Gray Sand
Field Description of Soil

447.1
Mass of Dry Sample (g), M

50 - 58
Depth of Sample (m)

Sieve No.	Diameter (mm)	Mass of Sieve (g)	Mass retained (sieve + soil) (g)	% Retained	% Passing
4	4.75	515.7	515.8	0%	100%
10	2	490.7	496.7	1%	99%
20	0.85	412.6	500.2	20%	79%
40	0.425	381.9	453.2	16%	63%
60	0.25	366.8	413.9	11%	53%
140	0.106	342.5	406.3	14%	38%
200	0.075	338.7	376.9	9%	30%
Pan		364.0	497.5	30%	

% Passing = 100 - % Retained

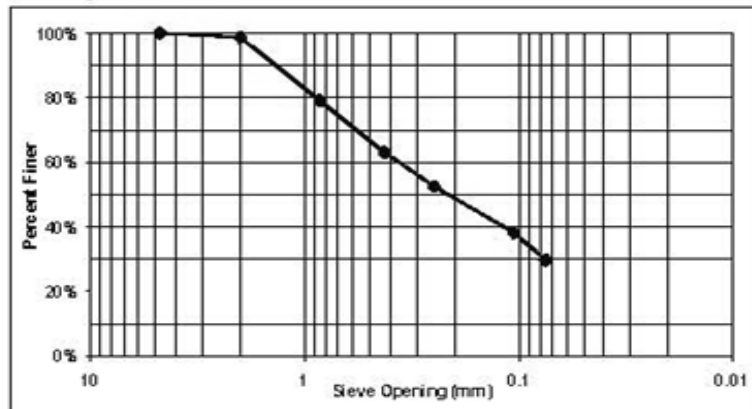

Detailed soils analysis



The University of New Mexico

UNIVERSITY OF NEWMEXICO
DEPARTMENT OF CIVIL ENGINEERING

HYDROMETER ANALYSIS

Project Urban Flood Demonstration Project		Tested By J. Pedro		Date 20-Feb-2007
Soil Identification WNS	Cylinder # 2	Depth (cm) 12.5 - 19	Time 11:37 AM	Sample Weight 50.0
Specific Gravity 2.70	Mixture # on Form (S) 28.1	Notes Soil Bag 3, Pan 2		

MENISCUS CORRECTION (m)	<u>2</u>
G _s CORRECTION FACTOR (α)	<u>0.99</u>
SUSPENSION CONSTANT (K)	<u>0.01312</u>
CORRECTED SAMPLE WT. (W _s)	<u>38.5</u>
PERCENT PASSING #200 SIEVE	<u>30%</u>

Elapsed Time (min)	Hydrometer Reading		Temperature (°C)	Effective Depth (cm)		Particle Diameter (mm)	% Finer (%)
	Orig.	R _s		R _{s(Corr)}	Corrected		
2	21	19	22	13.2	13.0680	0.0335	14.7%
5	16	14	22	14.0	13.8600	0.0218	10.8%
10	14	12	22	14.3	14.1570	0.0156	9.3%
15	14	12	22	14.3	14.1570	0.0127	9.3%
20	14	12	22	14.3	14.1570	0.0110	9.3%
30	13	11	22	14.5	14.3550	0.0091	8.5%
60	11	9	22	14.8	14.6520	0.0065	7.0%
250	10	8	23	15.0	14.8500	0.0032	6.2%
1440	9	7	23	15.2	15.0480	0.0013	5.4%

Detailed soils analysis



UNIVERSITY OF NEW MEXICO
DEPARTMENT OF CIVIL ENGINEERING

HYDROMETER ANALYSIS

The University of New Mexico

Project Urban Flood Demonstration Project		Requested By J. Pedro		Date 20 Feb 2007
Soiling Identification WNS	Cylinder # 3	Depth (cm) 34.5 - 38	Time 11:45 AM	Sample Wt. (g) 50.0
Specific Gravity 2.70	Mohr Pan Cont. (g) 29.7	Notes Soil Bag 7, Pan 4		

MENISCUS CORRECTION (m)	<u>2</u>
G _s CORRECTION FACTOR (α)	<u>0.99</u>
SUSPENSION CONSTANT (K)	<u>0.01312</u>
CORRECTED SAMPLE WT. (W _s)	<u>35.2</u>
PERCENT PASSING #200 SIEVE	<u>44%</u>

Elapsed Time (min)	Hydrometer Reading		Temperature (°C)	Effective Depth (cm)		Particle Diameter (mm)	% Finer (%)
	Orig.	R _s		R _{s(Corr)}	Corrected		
2	25	23	22	12.5	12.3750	0.0326	28.5%
5	24	22	22	12.7	12.5730	0.0208	27.3%
10	22	20	22	13.0	12.8700	0.0149	24.8%
15	21	19	22	13.2	13.0680	0.0122	23.5%
20	20	18	22	13.3	13.1670	0.0106	22.3%
30	19	17	22	13.5	13.3650	0.0088	21.1%
60	18	16	22	13.7	13.5630	0.0062	19.8%
250	16	14	23	14.0	13.8600	0.0031	17.3%
1440	15	13	22	14.2	14.0580	0.0013	16.1%

Detailed soils analysis



UNIVERSITY OF NEWMEXICO
DEPARTMENT OF CIVIL ENGINEERING

HYDROMETER ANALYSIS

The University of New Mexico

Project		Analyst		Date	
Urban Flood Demonstration Project		I. Pedro		2 Feb 2007	
Soiling Identification	Cylinder #	Depth (cm)	Time		Sample Wt. (g)
WNS	4	38 - 41.5	12:00 PM		50.0
Specific Gravity	Moisture Content (%)		Notes		
2.70	32.8		Soil Bag 8, Pan 5		

MENISCUS CORRECTION (m)	<u>2</u>
G _s CORRECTION FACTOR (α)	<u>0.99</u>
SUSPENSION CONSTANT (k)	<u>0.01312</u>
CORRECTED SAMPLE WT. (W _s)	<u>33.6</u>
PERCENT PASSING #200 SIEVE	<u>45%</u>

Elapsed Time (min)	Hydrometer Reading		Temperature (°C)	Effective Depth (cm)		Particle Diameter (mm)	% Finer (%)
	Orig.	R _s		R _{s(Corr)}	Corrected		
2	26	24	22	12.4	12.2760	0.0325	31.8%
5	24	22	22	12.7	12.5730	0.0208	29.2%
10	22	20	22	13.0	12.8700	0.0149	26.5%
15	21	19	22	13.2	13.0680	0.0122	25.2%
20	20	18	22	13.3	13.1670	0.0106	23.9%
30	19	17	23	13.5	13.3650	0.0088	22.5%
60	18	16	23	13.7	13.5630	0.0062	21.2%
250	16	14	23	14.0	13.8600	0.0031	18.6%
1440	15	13	22	14.2	14.0580	0.0013	17.2%

Detailed soils analysis



UNIVERSITY OF NEW MEXICO
DEPARTMENT OF CIVIL ENGINEERING

GRAIN SIZE ANALYSIS

Urban Flood Demonstration Project
Project
I. P. Pedro
Tested By

WNS (Bobcat S)
Boring Identification
2 3
Pan No. Soil Bag

Sieve No.	Diameter (mm)	% Passing
4	4.75	100%
10	2	100%
20	0.85	94%
40	0.425	84%
60	0.25	75%
140	0.106	45%
200	0.075	30%
	0.0335	14.7%
	0.0218	10.8%
	0.0156	9.3%
	0.0127	9.3%
	0.0110	9.3%
	0.0091	8.5%
	0.0065	7.0%
	0.0032	6.2%
	0.0013	5.4%

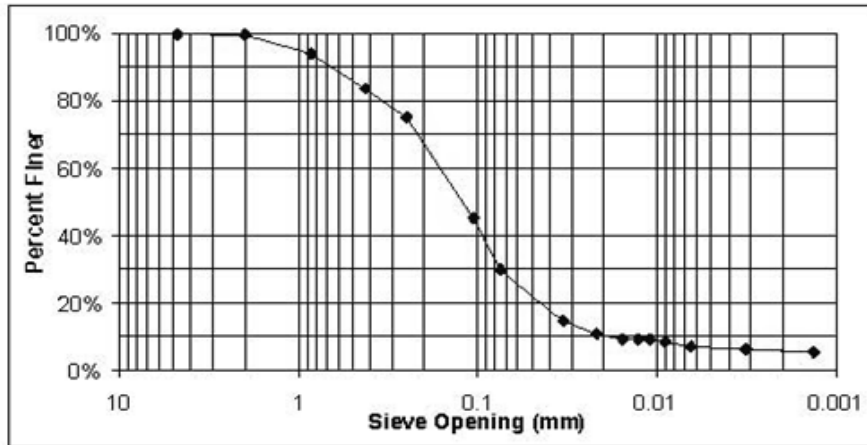

Detailed soils analysis



UNIVERSITY OF NEW MEXICO
DEPARTMENT OF CIVIL ENGINEERING

GRAIN SIZE ANALYSIS

Urban Flood Demonstration Project
Project
I. Pedro
Tested By

WNS (Bobcat S)
Boring Identification
4 7
Pan No. Soil Bag

Sieve No.	Diameter (mm)	% Passing
4	4.75	100%
10	2	100%
20	0.85	92%
40	0.425	80%
60	0.25	74%
140	0.106	57%
200	0.075	44%
	0.0326	28.5%
	0.0208	27.3%
	0.0149	24.8%
	0.0122	23.5%
	0.0106	22.3%
	0.0088	21.1%
	0.0062	19.8%
	0.0031	17.3%
	0.0013	16.1%

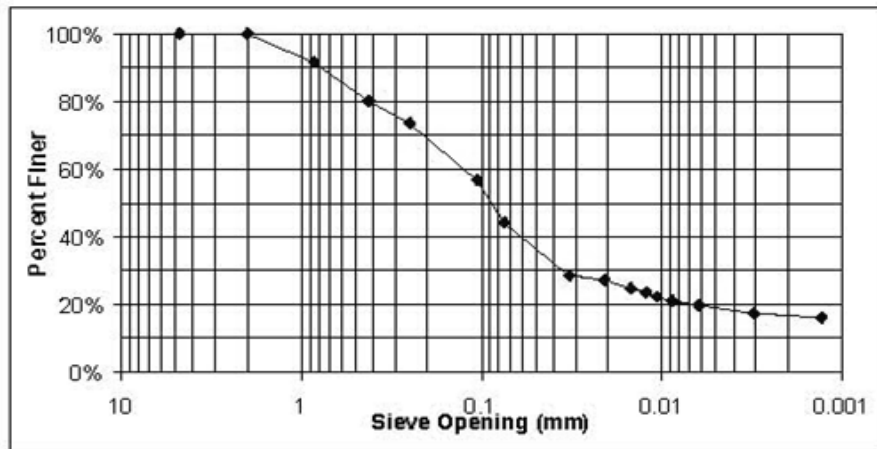

Detailed soils analysis



UNIVERSITY OF NEW MEXICO
DEPARTMENT OF CIVIL ENGINEERING

GRAIN SIZE ANALYSIS

Urban Flood Demonstration Project
Project
I. Pedro
Tested By

WNS (Bobcat S)
Boring Identification
5 8
Pan No. Soil Bag

Sieve No.	Diameter (mm)	% Passing
4	4.75	100%
10	2	100%
20	0.85	89%
40	0.425	76%
60	0.25	69%
140	0.106	57%
200	0.075	45%
	0.0325	31.8%
	0.0208	29.2%
	0.0149	26.5%
	0.0122	25.2%
	0.0106	23.9%
	0.0088	22.5%
	0.0062	21.2%
	0.0031	18.6%
	0.0013	17.2%

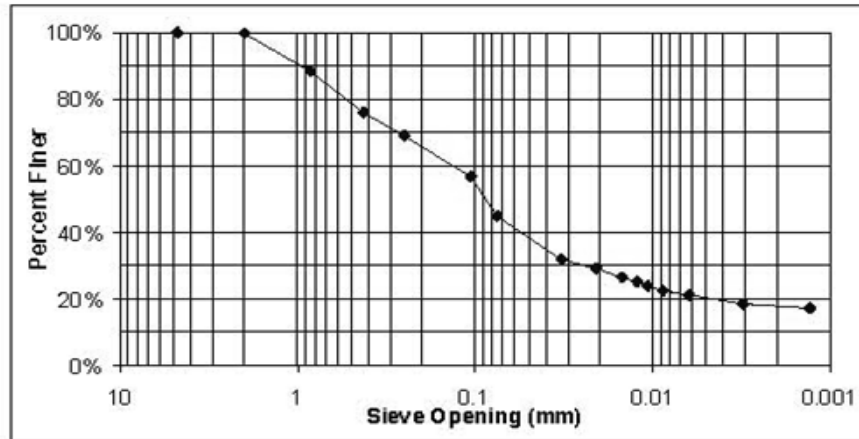

Detailed soils analysis



UNIVERSITY OF NEW MEXICO
DEPARTMENT OF CIVIL ENGINEERING

SOIL BORING LOG INFORMATION

PAGE 1 of 1

The University of New Mexico

Project Name Urban Flood Demonstration Project		Boring Classification ID WNC		Date of Drilling 8-Aug-06		Corresponding Well ID Bobcat (WU22) Center		
Boring Drilled By: I. Pedro & C. LeJeune		Canopy Rain Gage N/A		Open Rain Gage N/A		Weather Sunny and Partly Cloudy		
Boring Location 3 Feet SW of Well		# of Soil Bags Collected 13		Water Table Depth 55.5"		Final Depth 59"		
				Well Borer Depth 49.5"		Temperature 88 F		
DEPTH (IN)	SAMPLE NUMBER	DESCRIPTION (Visual-Manual Method)						COMMENTS
		MOISTURE	COLOR	DRY STRENGTH	DILATANCY	TOUGHNESS	PLASTICITY	
0	0							Lots of leaves, twigs and organic material
2	1	M	DBm	VH	H	M	M	Organic material present, material came out in clumps
6	2	M	Brn	VH	N	M	M	↓
11.5	3	VM	Bm	VH	N	H	H	Clayey appearance
17.5	4	VM	RBm	VH	N	H	H	Clumpy and clayey appearance
22.5	5	VM	RBm	VH	N	H	H	↓
26.5	6	VM	RBm	H	N	H	H	Encountered glass shards within soil sample
31	7	VM	LBm	M	S	L	L	Sandy appearance
35.5	8	VM	LBm	H	S	L	L	↓
38	9	VM	LBm	L	S	M	M	↓
40.5	10	VM	Gr	H	S	M	M	Sandy clay appearance and smell
45.5	11	VM	Gr	L	S	L	M	↓
51	12	VM	Gr	M	R	L	L	↓
59	13	W	Gr					Water table reached @ 55.5". Too saturated for VMM testing
I hereby certify that the information of this form is true and correct to the best of my knowledge								
Signature				Print Name		Date		
				Isaiah Pedro / Christian LeJeune		8-Aug-06		

Detailed soils analysis



UNIVERSITY OF NEW MEXICO
DEPARTMENT OF CIVIL ENGINEERING

WATER CONTENT DETERMINATION

Urban Flood Demonstration Project
Project

I. Pedro & C. LeJeune
Tested By

November 9, 2006
Date of Testing

November 10, 2006
Date of Dry Weighing

WNC (Bobcat C)
Boring Identification

CONTAINER NO. (CUP)	7	8	9	10	11	12	13
FIELD TEXTURE	OM	Sand w/Clay	Sand w/Clay	L.Brown Sand	L.Brown Sand	Gray Sand	Gray Sand
BORING BAG NO.	1	3	5	7	9	10	12
DEPTH (in)	0 - 2	6 - 11.5	17.5 - 22.5	26.5 - 31	35.5 - 38	38 - 40.5	45.5 - 51
MASS OF CUP + WET SOIL (g)	313.3	663.2	698.4	632.6	713.6	254.9	913.0
MASS OF CUP + DRY SOIL (g)	266.7	523.3	555.1	554.9	605.7	234.3	721.2
MASS OF CUP (g)	137.8	138.0	139.4	139.4	137.6	137.2	138.6
MASS OF DRY SOIL, Ms (g)	128.9	385.3	415.7	415.5	468.1	97.1	582.6
MASS OF WATER, Mw (g)	46.6	139.9	143.3	77.7	107.9	20.6	191.8
WATER CONTENT, w (%)	36.2%	36.3%	34.5%	18.7%	23.1%	21.2%	32.9%

CONTAINER NO. (CUP)							
FIELD TEXTURE							
BORING BAG NO.							
DEPTH (in)							
MASS OF CUP + WET SOIL (g)							
MASS OF CUP + DRY SOIL (g)							
MASS OF CUP (g)							
MASS OF DRY SOIL, Ms (g)							
MASS OF WATER, Mw (g)							
WATER CONTENT, w (%)							

$$w = \frac{M_w}{M_s} (100) \%$$

Detailed soils analysis



UNIVERSITY OF NEW MEXICO
DEPARTMENT OF CIVIL ENGINEERING

GRAIN SIZE ANALYSIS

Urban Flood Demonstration Project
Project

WNC (Bobcat C)
Boring Identification

L. Pedro
Tested By

7 1 1
Pan No. Soil Bag No. Sieve Set

November 10, 2006
Date of Testing

OM
Field Description of Soil

128.9
Mass of Dry Sample (g), M

0 - 2
Depth of Sample (m)

Sieve No.	Diameter (mm)	Mass of Sieve (g)	Mass retained (sieve + soil) (g)	% Retained	% Passing
4	4.75	503.2	503.2	0%	100%
10	2	464.4	466.7	2%	98%
20	0.85	413.1	466.9	42%	56%
40	0.425	370.0	394.6	19%	37%
60	0.25	354.0	364.4	8%	29%
140	0.106	342.0	353.2	9%	21%
200	0.075	327.7	331.8	3%	17%
Pan		364.0	385.3	17%	

% Passing = 100 - % Retained

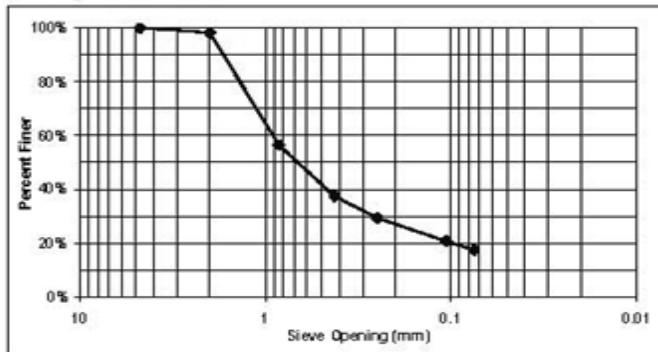

Detailed soils analysis



UNIVERSITY OF NEW MEXICO
DEPARTMENT OF CIVIL ENGINEERING

GRAIN SIZE ANALYSIS

The University of New Mexico

Urban Flood Demonstration Project
Projec

WNC (Bobcat C)
Boring Identification

I. Pedro
Tested By

8 3 2
Pan No. Soil Bag No. Sieve Set

November 10, 2006
Date of Testing

Sand with Clay
Field Description of Soil

385.3
Mass of Dry Sample (g), M

6 - 11.5
Depth of Sample (h)

Sieve No.	Diameter (mm)	Mass of Sieve (g)	Mass retained (sieve + soil) (g)	% Retained	% Passing
4	4.75	515.7	515.8	0%	100%
10	2	490.7	521.9	8%	92%
20	0.85	412.6	539.5	33%	59%
40	0.425	381.9	455.5	19%	40%
60	0.25	366.8	404.6	10%	30%
140	0.106	342.5	379.7	10%	20%
200	0.075	338.7	350.5	3%	17%
Pan		364.0	429.2	17%	

% Passing = 100 - % Retained

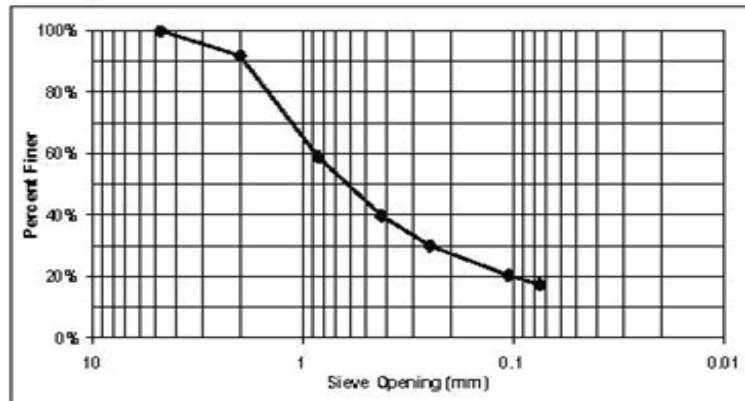

Detailed soils analysis



UNIVERSITY OF NEW MEXICO
DEPARTMENT OF CIVIL ENGINEERING

GRAIN SIZE ANALYSIS

Urban Flood Demonstration Project
Project

WNC (Bobcat C)
Boring Identification

L. Pedro
Tested By

9 Pan No. 5 Soil Bag No. 1 Sieve Set

November 10, 2006
Date of Testing

Sand with Clay
Field Description of Soil

415.7
Mass of Dry Sample (g), M_s

17.5 - 22.5
Depth of Sample (ft)

Sieve No.	Diameter (mm)	Mass of Sieve (g)	Mass retained (sieve + soil) (g)	% Retained	% Passing
4	4.75	503.2	504.3	0%	100%
10	2	464.4	485.6	5%	95%
20	0.85	413.1	552.4	34%	61%
40	0.425	370.0	450.6	19%	42%
60	0.25	354.0	396.0	10%	32%
140	0.106	342.0	399.2	14%	18%
200	0.075	327.7	350.6	6%	12%
Pan		364.0	416.8	12%	

% Passing = 100 - Σ% Retained

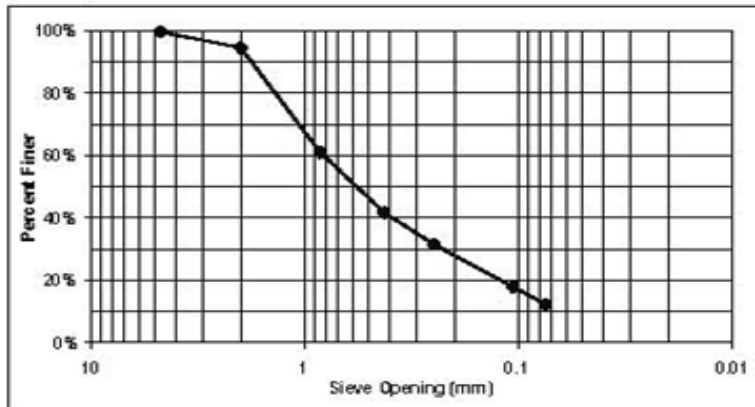

Detailed soils analysis



The University of New Mexico

UNIVERSITY OF NEW MEXICO
DEPARTMENT OF CIVIL ENGINEERING

GRAIN SIZE ANALYSIS

Urban Flood Demonstration Project
Project

WNC (Bobcat C)
Boring Identification

I. Pedro
Tested By

10 Pan No. 7 Soil Bag No. 2 Sieve Set

November 10, 2006
Date of Testing

Light Brown Sand
Field Description of Soil

415.5
Mass of Dry Sample (g), M_s

26.5 - 31
Depth of Sample (m)

Sieve No.	Diameter (mm)	Mass of Sieve (g)	Mass retained (sieve + soil) (g)	% Retained	% Passing
4	4.75	515.7	515.8	0%	100%
10	2	490.7	496.3	1%	99%
20	0.85	412.6	442.7	7%	91%
40	0.425	381.9	410.9	7%	84%
60	0.25	366.8	400.5	8%	76%
140	0.106	342.5	511.1	41%	36%
200	0.075	338.7	397.5	14%	22%
Pan		364.0	453.8	22%	

% Passing = 100 - % Retained

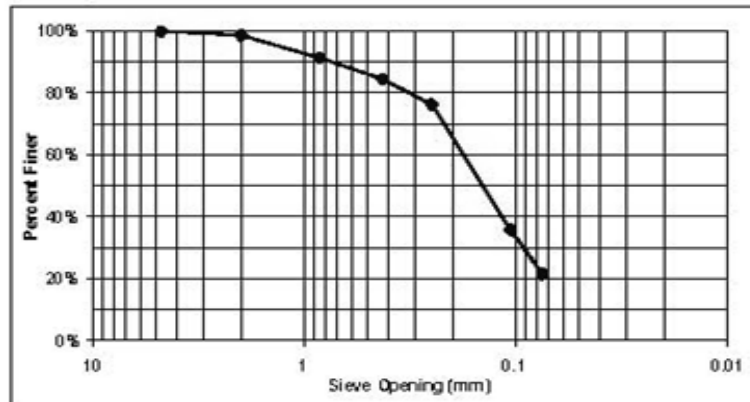

Detailed soils analysis



UNIVERSITY OF NEW MEXICO
DEPARTMENT OF CIVIL ENGINEERING

GRAIN SIZE ANALYSIS

Urban Flood Demonstration Project
Project

WNC (Bobcat C)
Boring Identification

I. Pedro
Tested By

11 Pan No. 9 Soil Bag No. 1 Sieve Set

November 10, 2006
Date of Testing

Light Brown Sand
Field Description of Soil

468.1
Mass of Dry Sample (g), M

35.5 - 38
Depth of Sample (m)

Sieve No.	Diameter (mm)	Mass of Sieve (g)	Mass retained (sieve + soil) (g)	% Retained	% Passing
4	4.75	503.2	503.2	0%	100%
10	2	464.4	465.3	0%	100%
20	0.85	413.1	487.1	16%	84%
40	0.425	370.0	440.2	15%	69%
60	0.25	354.0	400.4	10%	59%
140	0.106	342.0	448.2	23%	36%
200	0.075	327.7	374.0	10%	27%
Pan		364.0	489.3	27%	

% Passing = 100 - % Retained

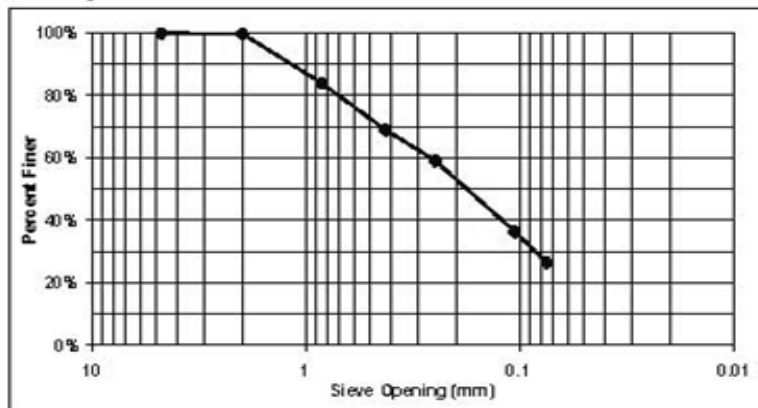

Detailed soils analysis



UNIVERSITY OF NEW MEXICO
DEPARTMENT OF CIVIL ENGINEERING

GRAIN SIZE ANALYSIS

The University of New Mexico

Urban Flood Demonstration Project
Project

WNC (Bobcat C)
Boring Identification

I. Pedro
Tested By

12 Pan No. 10 Soil Bag No. 2 Sieve Set

November 10, 2006
Date of Testing

Gray Sand
Field Description of Soil

97.1
Mass of Dry Sample (g), M

38 - 40.5
Depth of Sample (ft)

Sieve No.	Diameter (mm)	Mass of Sieve (g)	Mass retained (sieve + soil) (g)	% Retained	% Passing
4	4.75	515.7	515.7	0%	100%
10	2	490.7	491.3	1%	99%
20	0.85	412.6	423.3	11%	88%
40	0.425	381.9	395.3	14%	75%
60	0.25	366.8	377.7	11%	63%
140	0.106	342.5	370.7	29%	34%
200	0.075	338.7	349.3	11%	23%
Pan		364.0	387.1	23%	

% Passing = 100 - % Retained

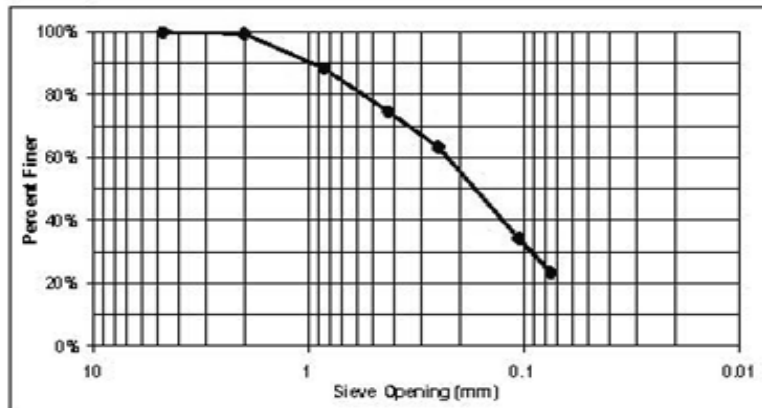

Detailed soils analysis



The University of New Mexico

UNIVERSITY OF NEW MEXICO
DEPARTMENT OF CIVIL ENGINEERING

GRAIN SIZE ANALYSIS

Urban Flood Demonstration Project
Project

WNC (Bobcat C)
Boring Identification

I. Pedro
Tested By

13 12 1
Pan No. Soil Bag No. Sieve Set

November 10, 2006
Date of Testing

Gray Sand
Field Description of Soil

582.6
Mass of Dry Sample (g), M

45.5 - 51
Depth of Sample (n)

Sieve No.	Diameter (mm)	Mass of Sieve (g)	Mass retained (sieve + soil) (g)	% Retained	% Passing
4	4.75	503.2	503.3	0%	100%
10	2	464.4	464.9	0%	100%
20	0.85	413.1	441.6	5%	95%
40	0.425	370.0	438.6	12%	83%
60	0.25	354.0	434.0	14%	69%
140	0.106	342.0	570.1	39%	30%
200	0.075	327.7	402.0	13%	18%
Pan		364.0	467.8	18%	

% Passing = 100 - % Retained

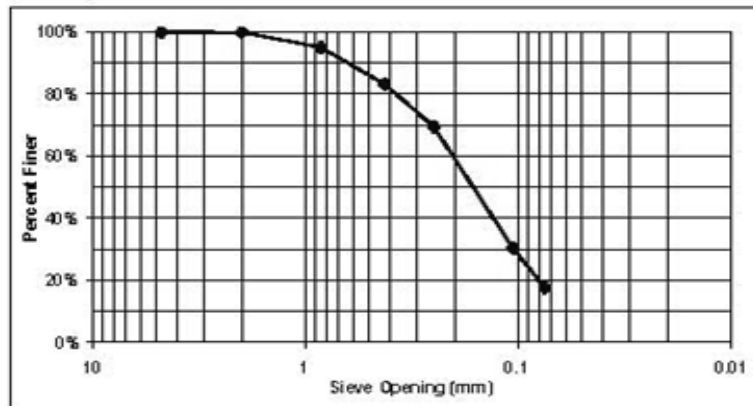

Detailed soils analysis



The University of New Mexico

UNIVERSITY OF NEW MEXICO
DEPARTMENT OF CIVIL ENGINEERING

HYDROMETER ANALYSIS

Project		Analyst		Date	
Urban Flood Demonstration Project		J. Pedro		15- Feb-2007	
Boring Identification	Cylinder #	Depth (m)	Time	Sample Weight	
WNC	2	36.5 - 38	1:20 PM	50.0	
Specific Gravity	Moisture Content (%)		Notes		
2.70	23.1		Soil Bag 9, Pan 11		

MENISCUS CORRECTION (m)	<u>0</u>
G _s CORRECTION FACTOR (α)	<u>0.99</u>
SUSPENSION CONSTANT (k)	<u>0.01312</u>
CORRECTED SAMPLE WT. (W _s)	<u>38.5</u>
PERCENT PASSING #200 SIEVE	<u>27%</u>

Elapsed Time (min)	Hydrometer Reading		Temperature (°C)	Effective Depth (cm)		Particle Diameter (mm)	% Finer (%)
	Orig.	R _a		R _{a(Corr)}	Corrected		
2	31	31	22	11.2	11.0680	0.0309	21.6%
5	25	25	21	12.2	12.0780	0.0204	17.4%
10	21	21	22	12.9	12.7710	0.0148	14.6%
15	19	19	22	13.2	13.0680	0.0122	13.2%
20	16	16	22	13.7	13.5630	0.0108	11.1%
30	15	15	22	13.8	13.6620	0.0089	10.4%
60	14	14	22	14.0	13.8600	0.0063	9.7%
250	12	12	22	14.3	14.1570	0.0031	8.3%
1440	10	10	22	14.7	14.5630	0.0013	7.0%

Detailed soils analysis



The University of New Mexico

UNIVERSITY OF NEWMEXICO
DEPARTMENT OF CIVIL ENGINEERING

HYDROMETER ANALYSIS

Project Urban Flood Demonstration Project		Analyst J. Pedro		Date 15-Feb-2007	
Soing Identification VNOC	Cylinder # 3	Depth (cm) 45.5 - 51	Time 1:29 PM	Sample Wt. (g) 50.0	
Specific Gravity 2.70	Moisture Content (%) 32.9		Notes Soil Bag 12, Pan 13		

MENISCUS CORRECTION (m) 0
 G_s CORRECTION FACTOR (α) 0.99
 SUSPENSION CONSTANT (k) 0.01312
 CORRECTED SAMPLE WT. (W_s) 33.6
 PERCENT PASSING #200 SIEVE 18%

Elapsed Time (min)	Hydrometer Reading		Temperature (°C)	Effective Depth (cm)		Particle Diameter (mm)	% Finer (%)
	Orig.	R_s		$R_{s(Corr)}$	Corrected		
2	21	21	22	12.9	12.7710	0.0332	11.2%
5	20	20	22	13.0	12.8700	0.0210	10.6%
10	15	15	22	13.8	13.6620	0.0153	8.0%
15	14	14	22	14.0	13.8600	0.0126	7.4%
20	13	13	22	14.2	14.0580	0.0110	6.9%
30	13	13	22	14.2	14.0580	0.0090	6.9%
60	11	11	22	14.5	14.3550	0.0064	5.8%
250	10	10	22	14.7	14.5530	0.0032	5.3%
1440	8	8	22	15.0	14.8500	0.0013	4.2%

Detailed soils analysis



UNIVERSITY OF NEW MEXICO
DEPARTMENT OF CIVIL ENGINEERING

GRAIN SIZE ANALYSIS

The University of New Mexico

Urban Flood Demonstration Project
Project
I. Pedro
Tested By

WNC (Bobcat C)
Boring Identification
11 9
Pan No. Soil Bag

Sieve No.	Diameter (mm)	% Passing
4	4.75	100%
10	2	100%
20	0.85	84%
40	0.425	69%
60	0.25	59%
140	0.106	36%
200	0.075	27%
	0.0309	21.6%
	0.0204	17.4%
	0.0148	14.6%
	0.0122	13.2%
	0.0108	11.1%
	0.0089	10.4%
	0.0063	9.7%
	0.0031	8.3%
	0.0013	7.0%

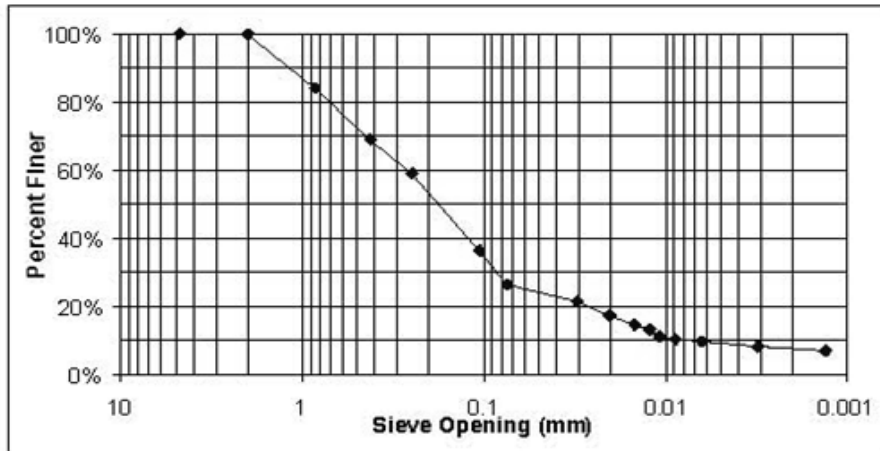

Detailed soils analysis



The University of New Mexico

UNIVERSITY OF NEW MEXICO
DEPARTMENT OF CIVIL ENGINEERING

GRAIN SIZE ANALYSIS

Urban Flood Demonstration Project
Project
I. Pedro
Tested By

WNC (Bobcat C)
Boring Identification
13 12
Pan No. Soil Bag

Sieve No.	Diameter (mm)	% Passing
4	4.75	100%
10	2	100%
20	0.85	95%
40	0.425	83%
60	0.25	69%
140	0.106	30%
200	0.075	18%
	0.0332	11.2%
	0.0210	10.6%
	0.0153	8.0%
	0.0126	7.4%
	0.0110	6.9%
	0.0090	6.9%
	0.0064	5.8%
	0.0032	5.3%
	0.0013	4.2%

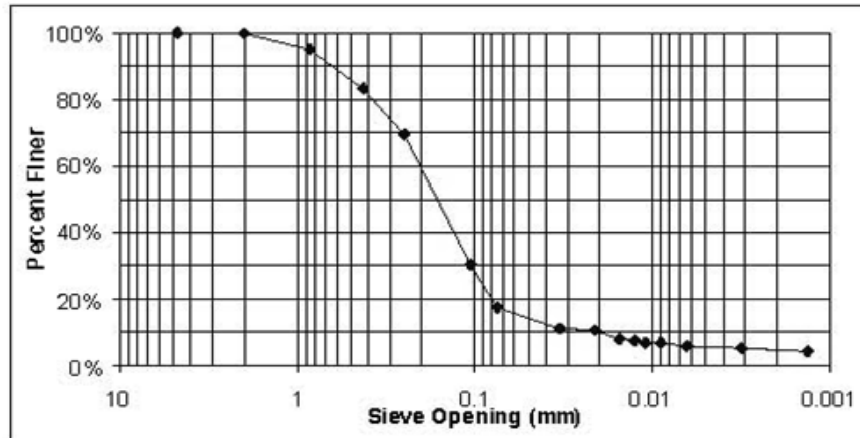

Detailed soils analysis



UNIVERSITY OF NEW MEXICO
DEPARTMENT OF CIVIL ENGINEERING

SOIL BORING LOG INFORMATION

PAGE 1 of 1

The University of New Mexico

Project Name Urban Flood Demonstration Project		Boring Classification ID WNE		Date of Drilling 9-Aug-06		Corresponding Well ID Bobcat (WU22) East		
Boring Drilled By J. Pedro & C. LeJeune		Canopy Rain Gage N/A		Open Rain Gage N/A		Weather Sunny, Partly Cloudy		
Boring Location 3 Feet SW of Well		# of Soil Bats Collected 12		Water Table Depth 47.75"		Final Depth 50"		
				Well Boper Depth 47"		Temperature 92 F		
SAMPLE		DESCRIPTION (Visual-Manual Method)						COMMENTS
DEPTH (IN)	NUMBER	MOISTURE	COLOR	DRY STRENGTH	DILATANCY	TOUGHNESS	PLASTICITY	
0	0	M	DBm					Grassy, leaves and twigs on top surface
2	1	M	DBm	H	S	H	H	Organic material and sandy appearance
8	2	M	Bm	H	S	M	H	Sandy appearance with organic material present
13.5	3	M	Bm	H	S	M	H	Same as above, some organic material & charcoal or asphalt fragments present.
19.5	4	M	Bm	VH	S	H	H	↓
25	5	VM	OBm	L	S	M	M	Sandy appearance. Encountered some roots.
29.5	6	M	OBm	M	S	L	L	↓
31	7	VM	OBm	L	S	L	N	↓
35.5	8	VM	Bm	H	S	H	H	Orange brown color change
39	9	VM	Bm	H	S	M	M	↓
42.5	10	VM	DBm	VH	S	M	M	Clayish smell and appearance
46	11	VM	Gr					Sandy clay appearance and smell. Too saturated for VMM testing
50	12	W	Gr					Water Table @ 47.75"
								**Rained High Before
I hereby certify that the information of this form is true and correct to the best of my knowledge								
Signature				Print Name				Date

Detailed soils analysis



UNIVERSITY OF NEW MEXICO
DEPARTMENT OF CIVIL ENGINEERING

WATER CONTENT DETERMINATION

The University of New Mexico

Urban Flood Demonstration Project
Project

J. Pedro & C. LaJeune
Tested By

November 16, 2006
Date of Testing

November 17, 2006
Date of Dry Weighing

WNE (Bobcat E)
Boring Identification

CONTAINER NO. (CUP)	1	2	3	4	5	6	7
FIELD TEXTURE	OM	Brown Sand	Brown Sand	D.Brown Sand	D.Brown Sand	Sand w/Clay	Sand w/Clay
BORING BAG NO.	1	2	4	5	7	8	10
DEPTH (in)	0 - 2	2 - 8	13.5 - 19.5	19.5 - 25	29.5 - 31	31 - 35.5	39 - 42.5
MASS OF CUP + WET SOIL (g)	292.8	599.0	829.1	759.5	417.3	524.0	482.5
MASS OF CUP + DRY SOIL (g)	264.5	531.5	722.4	641.2	374.9	447.9	399.8
MASS OF CUP (g)	139.2	138.6	139.1	139.2	138.9	139.0	137.8
MASS OF DRY SOIL, Ms (g)	125.3	392.9	583.3	502.0	236.0	308.9	262.0
MASS OF WATER, Mw (g)	28.3	67.5	106.7	118.3	42.4	76.1	82.7
WATER CONTENT, w (%)	22.6%	17.2%	18.3%	23.6%	18.0%	24.6%	31.6%

CONTAINER NO. (CUP)	8						
FIELD TEXTURE	Gray Sand						
BORING BAG NO.	12						
DEPTH (in)	46 - 50						
MASS OF CUP + WET SOIL (g)	715.0						
MASS OF CUP + DRY SOIL (g)	579.7						
MASS OF CUP (g)	138.0						
MASS OF DRY SOIL, Ms (g)	441.7						
MASS OF WATER, Mw (g)	135.3						
WATER CONTENT, w (%)	30.6%						

$$w = \frac{M_w}{M_s} (100) \%$$

Detailed soils analysis



UNIVERSITY OF NEW MEXICO
DEPARTMENT OF CIVIL ENGINEERING

GRAIN SIZE ANALYSIS

Urban Flood Demonstration Project
Project

WNE (Bobcat E)
Boring Identification

I. Pedro & C. LeJeune
Tested By

1 1 1
Pan No. Soil Bag No. Sieve Set

November 17, 2006
Date of Testing

OM
Field Description of Soil

125.3
Mass of Dry Sample (g), M_s

0 - 2
Depth of Sample (m)

Sieve No.	Diameter (mm)	Mass of Sieve (g)	Mass retained (sieve + soil) (g)	% Retained	% Passing
4	4.75	503.2	504.1	1%	99%
10	2	464.4	483.8	15%	84%
20	0.85	413.1	445.1	26%	58%
40	0.425	370.0	386.5	13%	45%
60	0.25	354.0	369.5	12%	33%
140	0.106	342.0	369.4	22%	11%
200	0.075	327.7	334.0	5%	6%
Pan		364.0	371.0	6%	

% Passing = 100 - Σ% Retained

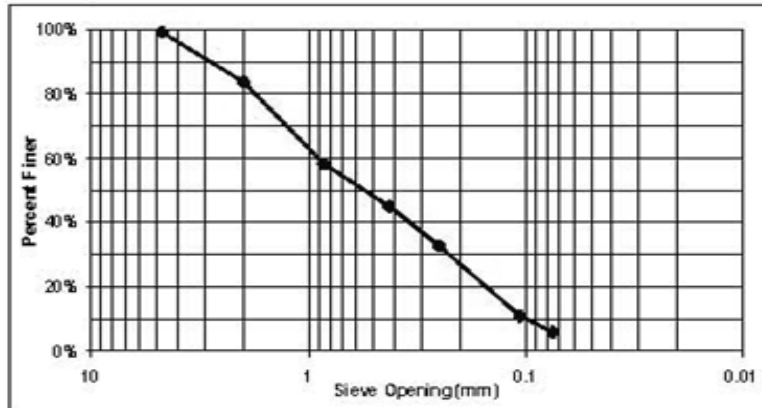

Detailed soils analysis



UNIVERSITY OF NEW MEXICO
DEPARTMENT OF CIVIL ENGINEERING

GRAIN SIZE ANALYSIS

Urban Flood Demonstration Project
Project

WNE (Bobcat E)
Boring Identification

I. Pedro & C. LeJeune
Tested By

2 Pan No. 2 Soil Bag No. 2 Sieve Set

November 17, 2006
Date of Testing

Brown Sand
Field Description of Soil

392.9
Mass of Dry Sample (g), M_s

2 - 8
Depth of Sample (ft)

Sieve No.	Diameter (mm)	Mass of Sieve (g)	Mass retained (sieve + soil) (g)	% Retained	% Passing
4	4.75	515.7	526.4	3%	97%
10	2	490.7	579.2	23%	75%
20	0.85	412.6	486.1	19%	56%
40	0.425	381.9	426.1	11%	45%
60	0.25	366.8	411.3	11%	33%
140	0.106	342.5	431.2	23%	11%
200	0.075	338.7	359.9	5%	5%
Pan		364.0	384.7	5%	

% Passing = 100 - % Retained

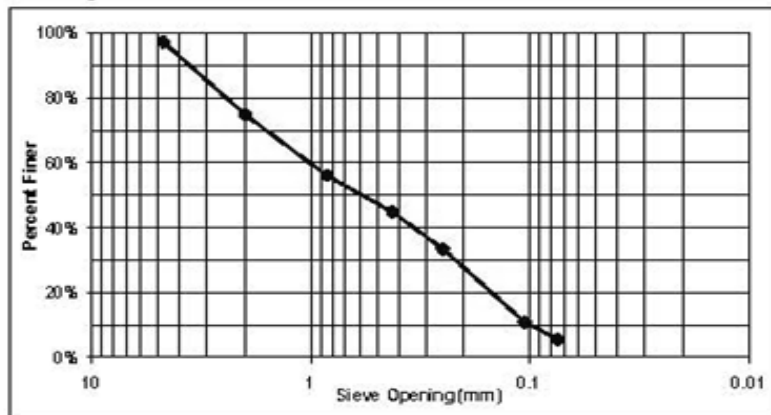

Detailed soils analysis



UNIVERSITY OF NEW MEXICO
DEPARTMENT OF CIVIL ENGINEERING

GRAIN SIZE ANALYSIS

The University of New Mexico

Urban Flood Demonstration Project
Project

WNE (Bobcat E)
Boring Identification

I. Pedro & C. LaJeune
Tested By

3 4 1
Pan No. Soil Bag No. Sieve Set

November 17, 2006
Date of Testing

Brown Sand
Field Description of Soil

583.3
Mass of Dry Sample (g), M

13.5 - 19.5
Depth of Sample (h)

Sieve No.	Diameter (mm)	Mass of Sieve (g)	Mass retained (sieve + soil) (g)	% Retained	% Passing
4	4.75	503.2	503.5	0%	100%
10	2	464.4	478.1	2%	98%
20	0.85	413.1	530.6	20%	77%
40	0.425	370.0	467.8	17%	61%
60	0.25	354.0	412.4	10%	51%
140	0.106	342.0	455.3	19%	31%
200	0.075	327.7	377.7	9%	23%
Pan		364.0	495.2	23%	

% Passing = 100 - % Retained

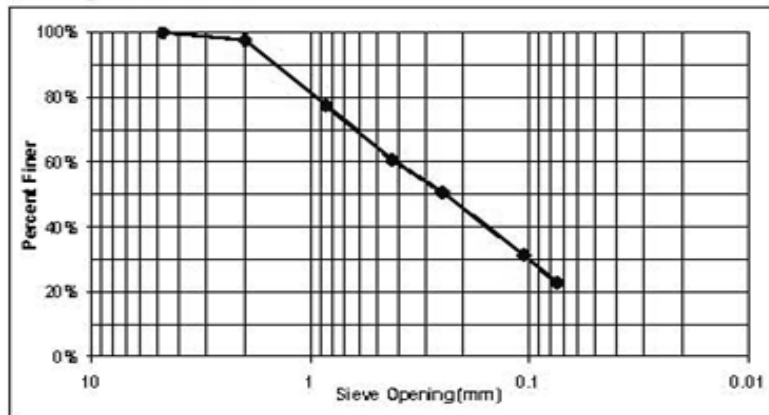

Detailed soils analysis



UNIVERSITY OF NEW MEXICO
DEPARTMENT OF CIVIL ENGINEERING

GRAIN SIZE ANALYSIS

Urban Flood Demonstration Project
Projec

WNE (Bobcat E)
Boring Identification

I. Pedro & C. LeJeune
Tested By

4 Pan No. 5 Soil Bag No. 2 Sieve Set

November 17, 2006
Date of Testing

Dark Brown Sand
Field Description of Soil

502
Mass of Dry Sample (g), M

19.5 - 25
Depth of Sample (ft)

Sieve No.	Diameter (mm)	Mass of Sieve (g)	Mass retained (sieve + soil) (g)	% Retained	% Passing
4	4.75	515.7	515.8	0%	100%
10	2	490.7	491.0	0%	100%
20	0.85	412.6	461.5	10%	90%
40	0.425	381.9	447.5	13%	77%
60	0.25	366.8	406.8	8%	69%
140	0.106	342.5	393.5	10%	59%
200	0.075	338.7	370.1	6%	53%
Pan		364.0	626.4	53%	

% Passing = 100 - % Retained



Detailed soils analysis



UNIVERSITY OF NEW MEXICO
DEPARTMENT OF CIVIL ENGINEERING

GRAIN SIZE ANALYSIS

Urban Flood Demonstration Project
Project

WNE (Bobcat E)
Boring Identification

I. Pedro & C. LeJeune
Tested By

5 Pan No. 7 Soil Bag No. 1 Sieve Set

November 17, 2006
Date of Testing

Dark Brown Sand
Field Description of Soil

236
Mass of Dry Sample (g), M

29.5 - 31
Depth of Sample (ft)

Sieve No.	Diameter (mm)	Mass of Sieve (g)	Mass retained (sieve + soil) (g)	% Retained	% Passing
4	4.75	503.2	503.3	0%	100%
10	2	464.4	475.3	5%	95%
20	0.85	413.1	437.0	10%	85%
40	0.425	370.0	382.6	5%	80%
60	0.25	354.0	370.9	7%	73%
140	0.106	342.0	389.8	20%	52%
200	0.075	327.7	374.8	20%	33%
Pan		364.0	441.6	33%	

% Passing = 100 - % Retained

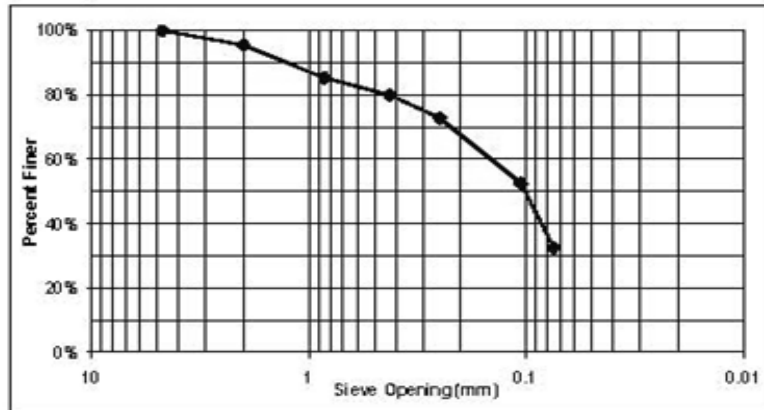

Detailed soils analysis



The University of New Mexico

UNIVERSITY OF NEW MEXICO
DEPARTMENT OF CIVIL ENGINEERING

GRAIN SIZE ANALYSIS

Urban Flood Demonstration Project
Project

WNE (Bobcat E)
Boring Identification

L. Pedro & C. LeJeune
Tested By

6 Pan No. 8 Soil Bag No. 2 Sieve Set

November 17, 2006
Date of Testing

Sand with Clay
Field Description of Soil

308.9
Mass of Dry Sample (g), M_s

31 - 35.5
Depth of Sample (ft)

Sieve No.	Diameter (mm)	Mass of Sieve (g)	Mass retained (sieve + soil) (g)	% Retained	% Passing
4	4.75	515.7	515.8	0%	100%
10	2	490.7	501.4	3%	97%
20	0.85	412.6	448.8	12%	85%
40	0.425	381.9	420.1	12%	72%
60	0.25	366.8	395.9	9%	63%
140	0.106	342.5	385.2	14%	49%
200	0.075	338.7	366.7	9%	40%
Pan		364.0	488.0	40%	

% Passing = 100 - % Retained

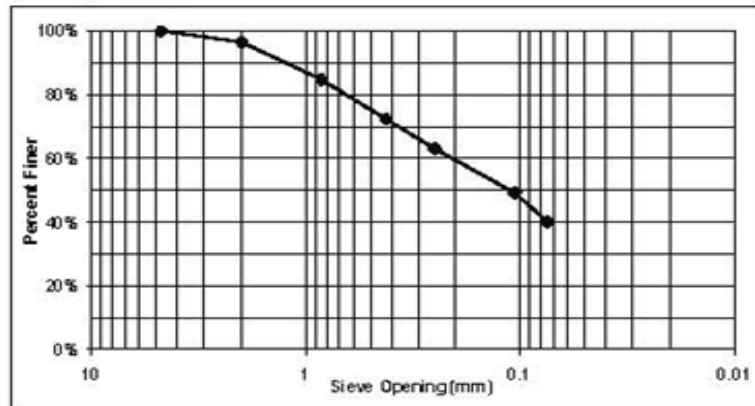

Detailed soils analysis



The University of New Mexico

UNIVERSITY OF NEW MEXICO
DEPARTMENT OF CIVIL ENGINEERING

GRAIN SIZE ANALYSIS

Urban Flood Demonstration Project
Project

WNE (Bobcat E)
Boring Identification

I. Pedro & C. LeJeune
Tested By

7 Pan No. 10 Soil Bag No. 1 Sieve Set

November 17, 2006
Date of Testing

Sand with Clay
Field Description of Soil

262
Mass of Dry Sample (g), M_s

39 - 42.5
Depth of Sample (m)

Sieve No.	Diameter (mm)	Mass of Sieve (g)	Mass retained (sieve + soil) (g)	% Retained	% Passing
4	4.75	503.2	503.2	0%	100%
10	2	464.4	468.6	2%	98%
20	0.85	413.1	460.4	18%	80%
40	0.425	370.0	408.9	15%	65%
60	0.25	354.0	374.7	8%	58%
140	0.106	342.0	373.6	12%	46%
200	0.075	327.7	351.3	9%	37%
Pan		364.0	461.8	37%	

% Passing = 100 - Σ% Retained



Detailed soils analysis



UNIVERSITY OF NEW MEXICO
DEPARTMENT OF CIVIL ENGINEERING

GRAIN SIZE ANALYSIS

The University of New Mexico

Urban Flood Demonstration Project
Project

WNE (Bobcat E)
Boring Identification

I. Pedro & C. LaJeune
Tested By

8 12 2
Pan No. Soil Bag No. Sieve Set

November 17, 2006
Date of Testing

Gray Sand
Field Description of Soil

441.7
Mass of Dry Sample (g), M_s

46 - 50
Depth of Sample (m)

Sieve No.	Diameter (mm)	Mass of Sieve (g)	Mass retained (sieve + soil) (g)	% Retained	% Passing
4	4.75	515.7	515.7	0%	100%
10	2	490.7	495.3	1%	99%
20	0.85	412.6	427.6	3%	96%
40	0.425	381.9	392.2	2%	93%
60	0.25	366.8	378.4	3%	91%
140	0.106	342.5	488.9	33%	57%
200	0.075	338.7	419.2	18%	39%
Pan		364	537	39%	

% Passing = 100 - % Retained

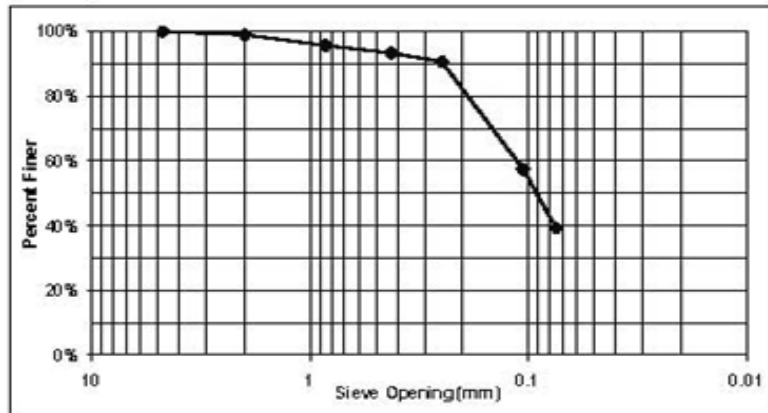

Detailed soils analysis



UNIVERSITY OF NEW MEXICO
DEPARTMENT OF CIVIL ENGINEERING

HYDROMETER ANALYSIS

The University of New Mexico

Project Urban Flood Demonstration Project		Analyzed By J. Pedro		Date 15- Feb-2007
Soil Identification WNE	Cylinder # 4	Depth (cm) 19.5 - 25	Time 1:40 PM	Sample Wt. (g) 50.0
Specific Gravity 2.70	Moisture Content (%) 23.6	Notes Soil Bag 5, Pan 4		

MENISCUS CORRECTION (m) 0
 G_s CORRECTION FACTOR (α) 0.99
 SUSPENSION CONSTANT (K) 0.01312
 CORRECTED SAMPLE WT. (W_s) 38.2
 PERCENT PASSING #200 SIEVE 53%

Elapsed Time (min)	Hydrometer Reading		Temperature (°C)	Effective Depth (cm)		Particle Diameter (mm)	% Finer (%)
	Orig.	R _s		R _{a(Corr)}	Corrected		
2	27	27	22	11.9	11.7810	0.0318	37.1%
5	21	21	22	12.9	12.7710	0.0210	28.8%
10	14	14	22	14.0	13.8600	0.0154	19.2%
15	12	12	22	14.3	14.1570	0.0127	16.5%
20	12	12	22	14.3	14.1570	0.0110	16.5%
30	10	10	22	14.7	14.5630	0.0091	13.7%
60	10	10	22	14.7	14.5630	0.0065	13.7%
250	8	8	22	15.0	14.8500	0.0032	11.0%
1440	6	6	22	15.3	15.1470	0.0013	8.2%

Detailed soils analysis



UNIVERSITY OF NEW MEXICO
DEPARTMENT OF CIVIL ENGINEERING

HYDROMETER ANALYSIS

The University of New Mexico

Project Urban Flood Demonstration Project		Issued By J. Pedra		Date 15- Feb-2007
Soil Identification WNE	Cylinder # 5	Depth (cm) 29.5 - 31	Time 1:53 PM	Sample Wt. (g) 50.0
Specific Gravity 2.70	Moisture Content (%) 18.0	No. test Soil Bag 7, Pan 5		

MENISCUS CORRECTION (m) 0
 G_s CORRECTION FACTOR (α) 0.99
 SUSPENSION CONSTANT (k) 0.01312
 CORRECTED SAMPLE WT. (W_s) 41.0
 PERCENT PASSING #200 SIEVE 33%

Elapsed Time (min)	Hydrometer Reading		Temperature (°C)	Effective Depth (cm)		Particle Diameter (mm)	% Finer (%)
	Orig.	R _s		R _{a(Corr)}	Corrected		
2	15	15	22	13.8	13.6620	0.0343	12.0%
5	10	10	22	14.7	14.5630	0.0224	8.0%
10	9	9	22	14.8	14.6520	0.0159	7.2%
15	8	8	22	15.0	14.8500	0.0131	6.4%
20	8	8	21	15.0	14.8500	0.0113	6.4%
30	7	7	22	15.2	15.0480	0.0093	5.6%
60	6	6	22	15.3	15.1470	0.0066	4.8%
250	5	5	22	15.5	15.3450	0.0033	4.0%
1440	4	4	22	15.6	15.4440	0.0014	3.2%

Detailed soils analysis



The University of New Mexico

UNIVERSITY OF NEW MEXICO
DEPARTMENT OF CIVIL ENGINEERING

HYDROMETER ANALYSIS

Project Urban Flood Demonstration Project		Tested By J. Pedro		Date 15-Feb-2007
Soiling Identification WNE	Cylinder # 6	Depth (cm) 31 - 35.5	Time 2:05 PM	Sample # (1.g) 50.0
Specific Gravity 2.70	Moisture Content (%) 24.6	Notes Soil Bag 8, Pan 6		

MENISCUS CORRECTION (m)	<u>0</u>
G _s CORRECTION FACTOR (α)	<u>0.99</u>
SUSPENSION CONSTANT (K)	<u>0.01312</u>
CORRECTED SAMPLE WT. (W _s)	<u>37.7</u>
PERCENT PASSING #200 SIEVE	<u>40%</u>

Elapsed Time (min)	Hydrometer Reading		Temperature (°C)	Effective Depth (cm)		Particle Diameter (mm)	% Finer (%)
	Orig.	R _s		R _{s(Corr)}	Corrected		
2	25	25	22	12.2	12.0780	0.0322	26.3%
5	18	18	22	13.3	13.1670	0.0213	18.9%
10	15	15	22	13.8	13.6620	0.0153	15.8%
15	12	12	22	14.3	14.1570	0.0127	12.6%
20	11	11	22	14.5	14.3550	0.0111	11.6%
30	10	10	22	14.7	14.5530	0.0091	10.5%
60	9	9	22	14.8	14.6520	0.0065	9.5%
250	9	9	22	14.8	14.6520	0.0032	9.5%
1440	7	7	22	15.2	15.0480	0.0013	7.4%

Detailed soils analysis



The University of New Mexico

UNIVERSITY OF NEW MEXICO
DEPARTMENT OF CIVIL ENGINEERING

GRAIN SIZE ANALYSIS

Urban Flood Demonstration Project
Project
I. Pedro
Tested By

WNE (Bobcat E)
Boring Identification
4 5
Pan No. Soil Bag

Sieve No.	Diameter (mm)	% Passing
4	4.75	100%
10	2	100%
20	0.85	90%
40	0.425	77%
60	0.25	69%
140	0.106	59%
200	0.075	53%
	0.0318	37.1%
	0.0210	28.8%
	0.0154	19.2%
	0.0127	16.5%
	0.0110	16.5%
	0.0091	13.7%
	0.0065	13.7%
	0.0032	11.0%
	0.0013	8.2%

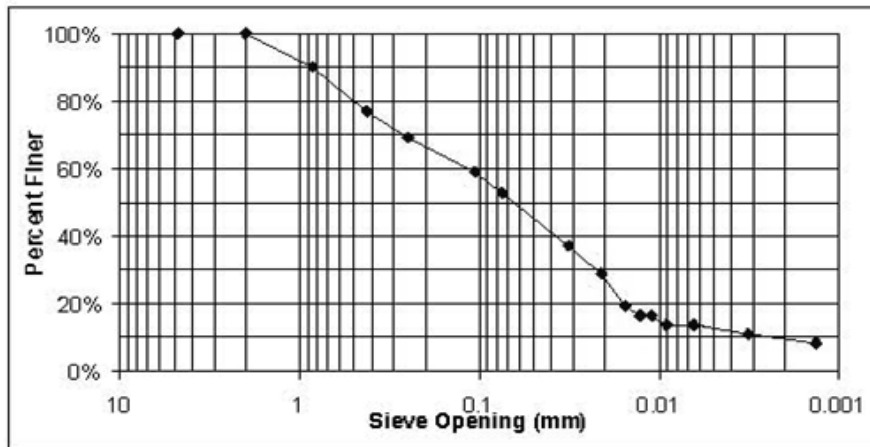

Detailed soils analysis



UNIVERSITY OF NEW MEXICO
DEPARTMENT OF CIVIL ENGINEERING

GRAIN SIZE ANALYSIS

Urban Flood Demonstration Project
Project
I. Pedro
Tested By

WNE (Bobcat E)
Boring Identification
5 7
Pan No. Soil Bag

Sieve No.	Diameter (mm)	% Passing
4	4.75	100%
10	2	95%
20	0.85	85%
40	0.425	80%
60	0.25	73%
140	0.106	52%
200	0.075	33%
	0.0343	12.0%
	0.0224	8.0%
	0.0159	7.2%
	0.0131	6.4%
	0.0113	6.4%
	0.0093	5.6%
	0.0066	4.8%
	0.0033	4.0%
	0.0014	3.2%

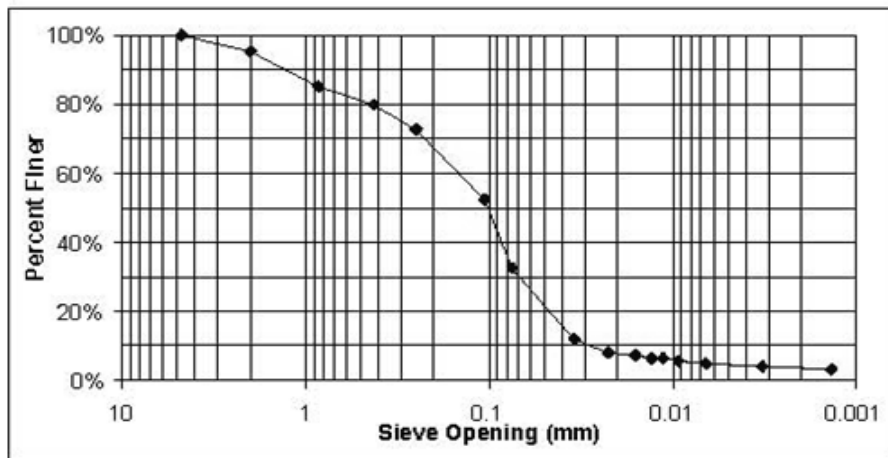

Detailed soils analysis



UNIVERSITY OF NEW MEXICO
DEPARTMENT OF CIVIL ENGINEERING

GRAIN SIZE ANALYSIS

The University of New Mexico

Urban Flood Demonstration Project
Project
I. Pedro
Tested By

WNE (Bobcat E)
Boring Identification
6 8
Pan No. Soil Bag

Sieve No.	Diameter (mm)	% Passing
4	4.75	100%
10	2	97%
20	0.85	85%
40	0.425	72%
60	0.25	63%
140	0.106	49%
200	0.075	40%
	0.0322	26.3%
	0.0213	18.9%
	0.0153	15.8%
	0.0127	12.6%
	0.0111	11.6%
	0.0091	10.5%
	0.0065	9.5%
	0.0032	9.5%
	0.0013	7.4%

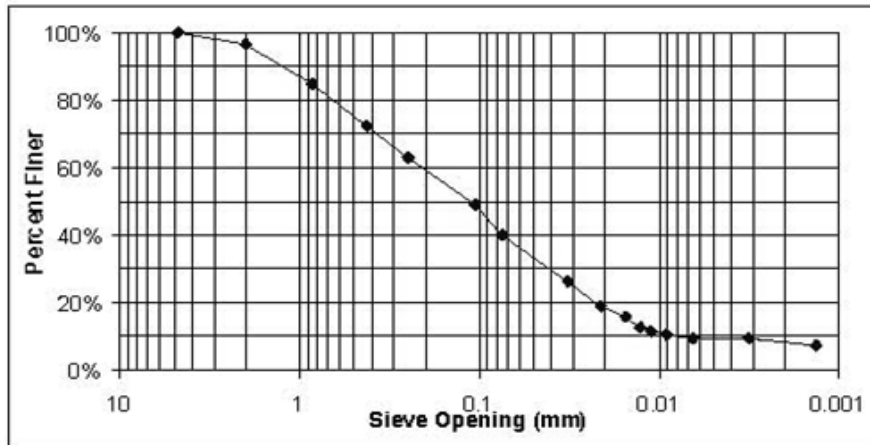

Detailed soils analysis

Appendix F: Badger (EU21) Core Data Sheets



UNIVERSITY OF NEW MEXICO
DEPARTMENT OF CIVIL ENGINEERING

SOIL BORING LOG INFORMATION

PAGE 1 of 1

The University of New Mexico

Project Name Urban Flood Demonstration Project		Boring Classification ID ENN		Date of Drilling 14-Aug-06		Corresponding Well ID Badger (EU21) North		
Boring Drilled By J. Pedro & C. LeJeune		Canopy Rain Gage N/A		Open Rain Gage N/A		Weather Cloudy		
Boring Location 6 Feet SW of Well		# of Soil Bags Collected 12		Water Table Depth 66"		Final Depth 67"		
				Well Bore Depth 85.25"		Temperature N/A		
SAMPLE		DESCRIPTION (Visual-Manual Method)						COMMENTS
DEPTH (ft)	NUMBER	MOISTURE	COLOR	DRY STRENGTH	DILATANCY	TOUGHNESS	PLASTICITY	
0	0	M	DBm					Organic material, leaves and twigs present
3	1	M	DBm					Organic material present with a more sandy appearance
8	2	M	Bm					
14.5	3	M	Bm					
21	4	M	Bm					
28.5	5	M	Bm					
35	6	M	Bm					Organic material present
41.5	7	VM	DBm					Clayey appearance with some organic material present
47.5	8	VM	Bm					Changes to a more sandy appearance
52.5	9	VM	Bm					
54	10	VM	Bm					
59.5	11	W	DBm					
67	12	W	DBm					
								**NO FIELD CLASSIFICATION PERFORMED
I hereby certify that the information of this form is true and correct to the best of my knowledge								
Signature				Print Name		Date		
				Isaiiah Pedro / Christian LeJeune		14-Aug-06		

Detailed soils analysis



UNIVERSITY OF NEW MEXICO
DEPARTMENT OF CIVIL ENGINEERING

WATER CONTENT DETERMINATION

The University of New Mexico

Urban Flood Demonstration Project
Project

C. LeJeune
Tested By

January 8, 2007
Date of Testing

January 9, 2007
Date of Dry Weighing

ENN (Badger N)
Boring Identification

CONTAINER NO. (CUP)	1	2	3*	4*	5	6	7
FIELD TEXTURE	OM	B. Sand	Sand w/ Clay	Sand w/ Clay	B. Sand	B. Sand	D.B. Sand
BORING BAG NO.	1	2	5	7	8	10	11
DEPTH (in)	0 - 3	3 - 8	21 - 28.5	35 - 41.5	41.5 - 47.5	52.5 - 54	54 - 59.5
MASS OF CUP + WET SOIL (g)	382.7	884.2	997.1	995.7	1033.5	298.6	816.3
MASS OF CUP + DRY SOIL (g)	334.9	772.3	857.5	823.9	894.5	271.1	659.2
MASS OF CUP (g)	139.2	138.6	139.1	139.2	138.9	139.0	137.8
MASS OF DRY SOIL, M _s (g)	195.7	633.7	718.4	684.7	755.6	132.1	521.4
MASS OF WATER, M _w (g)	47.8	111.9	139.6	171.8	139.0	27.5	157.1
WATER CONTENT, w (%)	24.4%	17.7%	19.4%	25.1%	18.4%	20.8%	30.1%

CONTAINER NO. (CUP)							
FIELD TEXTURE							
BORING BAG NO.							
DEPTH (in)							
MASS OF CUP + WET SOIL (g)							
MASS OF CUP + DRY SOIL (g)							
MASS OF CUP (g)							
MASS OF DRY SOIL, M _s (g)							
MASS OF WATER, M _w (g)							
WATER CONTENT, w (%)							

$$w = \frac{M_w}{M_s} (100) \%$$

*Sample to be washed

Detailed soils analysis



The University of New Mexico

UNIVERSITY OF NEW MEXICO
DEPARTMENT OF CIVIL ENGINEERING

GRAIN SIZE ANALYSIS

Urban Flood Demonstration Program
Projec

ENN (Badger N)
Boing Identification

I. Pedro & C. LeJeune
Tested By

1 1 1
Pan No. Soil Bag No. Sieve No.

January 9, 2007
Date of Testing

OM
Field Description of Soil

195.7
Mass of Dry Sample, M_s

0 - 3
Depth of Sample (m)

Sieve No.	Diameter (mm)	Mass of Sieve (g)	Mass retained (sieve + soil) (g)	% Retained	% Passing
4	4.75	503.2	505.4	1%	99%
10	2	464.4	466.4	1%	98%
20	0.85	413.1	420.4	4%	94%
40	0.425	370.0	388.4	9%	85%
60	0.25	354.0	403.5	25%	59%
140	0.106	342.0	433.2	47%	13%
200	0.075	327.7	339.2	6%	7%
Pan		364.0	376.9	7%	

% Passing = 100 - % Retained

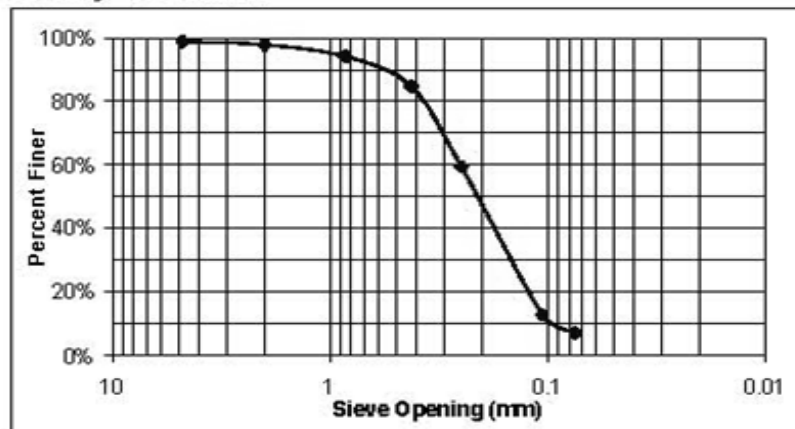

Detailed soils analysis



The University of New Mexico

UNIVERSITY OF NEW MEXICO
DEPARTMENT OF CIVIL ENGINEERING

GRAIN SIZE ANALYSIS

Urban Flood Demonstration Program
Projec

ENN (Badger N)
Boing Identification

I. Pedro & C. LeJeune
Tested By

2 Pan No. 2 Soil Bag No. 1 Sieve No.

January 9, 2007
Date of Testing

Brown Sand
Field Description of Soil

633.7
Mass of Dry Sample, M_s

3 - 8
Depth of Sample (in)

Sieve No.	Diameter (mm)	Mass of Sieve (g)	Mass retained (sieve + soil) (g)	% Retained	% Passing
4	4.75	503.2	508.0	1%	99%
10	2	464.4	467.5	0%	99%
20	0.85	413.1	445.9	5%	94%
40	0.425	370.0	442.3	11%	82%
60	0.25	354.0	458.3	16%	66%
140	0.106	342.0	626.9	45%	21%
200	0.075	327.7	386.1	9%	12%
Pan		364.0	435.8	11%	

% Passing = 100 - Σ% Retained

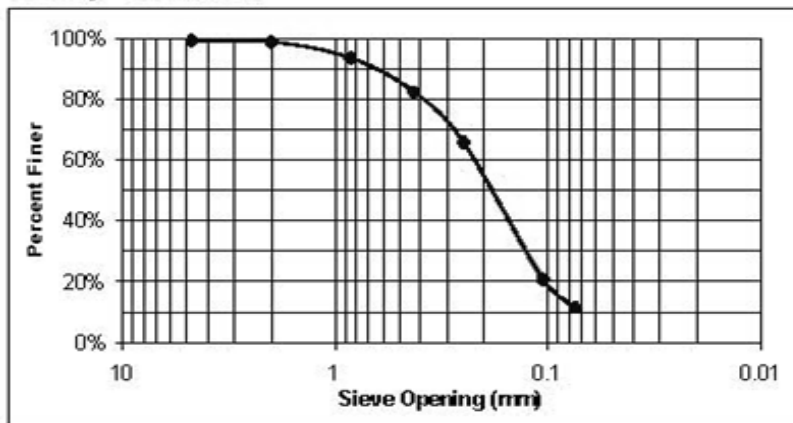

Detailed soils analysis



The University of New Mexico

UNIVERSITY OF NEW MEXICO
DEPARTMENT OF CIVIL ENGINEERING

GRAIN SIZE ANALYSIS

Urban Flood Demonstration Program

Projec

ENN (Badger N)

Boring Identification

I. Pedro & C. LeJeune

Tested By

3*
Pan No.

5
Soil Bag No.

1
Sieve No.

January 10, 2007

Date of Testing

Sand w/Clay

Field Description of Soil

718.4

Mass of Dry Sample, M_s

21 - 28.5

Depth of Sample (m)

*Washed Material

Sieve No.	Diameter (mm)	Mass of Sieve (g)	Mass retained (sieve + soil) (g)	% Retained	% Passing
4	4.75	503.2	503.7	0%	100%
10	2	464.4	464.7	0%	100%
20	0.85	413.1	413.8	0%	100%
40	0.425	370.0	371.9	0%	100%
60	0.25	354.0	364.1	1%	98%
140	0.106	342.0	496.4	21%	77%
200	0.075	327.7	429.9	14%	62%
Pan		364.0	812.2	62%	

% Passing = 100 - Σ% Retained

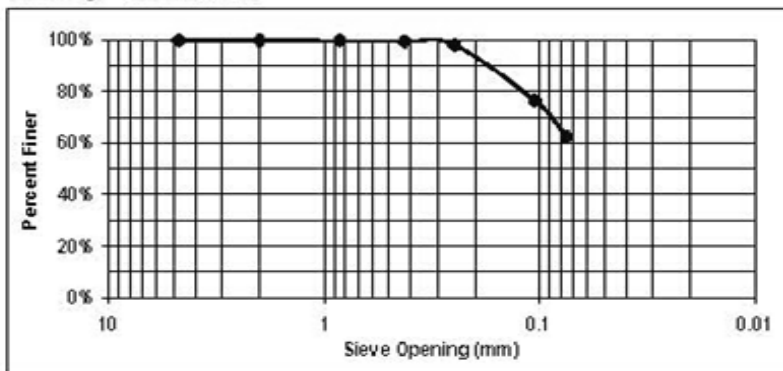

Detailed soils analysis



The University of New Mexico

UNIVERSITY OF NEW MEXICO
DEPARTMENT OF CIVIL ENGINEERING

GRAIN SIZE ANALYSIS

Urban Flood Demonstration Program

ENN (Badger N)

Projec

Boring Identification

I. Pedro & C. LeJeune

Tested By

4*
Pan No.

7
Soil Bag No.

2
Sieve No.

January 10, 2007

Date of Testing

Sand w/Clay

Field Description of Soil

684.7

Mass of Dry Sample, M_s

35 - 41.5

Depth of Sample (m)

*Washed Material

Sieve No.	Diameter (mm)	Mass of Sieve (g)	Mass retained (sieve + soil) (g)	% Retained	% Passing
4	4.75	515.7	515.7	0%	100%
10	2	490.7	491.1	0%	100%
20	0.85	412.6	416.3	1%	99%
40	0.425	381.9	392.9	2%	98%
60	0.25	366.8	383.5	2%	95%
140	0.106	342.5	433.0	13%	82%
200	0.075	338.7	403.2	9%	73%
Pan		364.0	861.3	73%	

% Passing = 100 - Σ% Retained

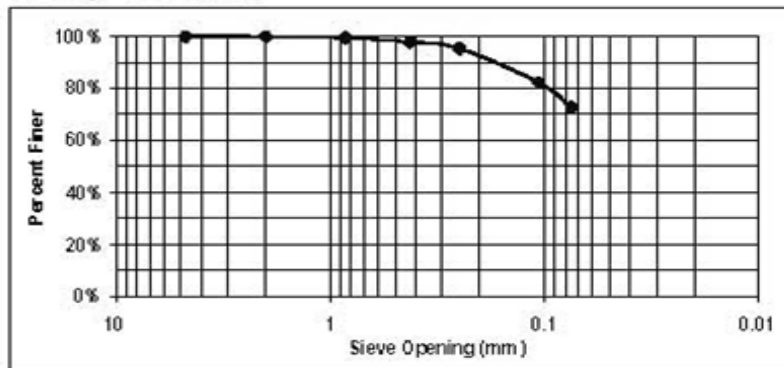

Detailed soils analysis



The University of New Mexico

UNIVERSITY OF NEW MEXICO
DEPARTMENT OF CIVIL ENGINEERING

GRAIN SIZE ANALYSIS

Urban Flood Demonstration Program

Projec

J. Pedro & C. LeJeune

Tested By

January 9, 2007

Date of Testing

755.6
Mass of Dry Sample, M_s

ENN (Badger N)

Boring Identification

5 8 2
Pan No. Soil Bag No. Sieve No.

Brown Sand

Field Description of Soil

41.5 - 47.5
Depth of Sample (n)

Sieve No.	Diameter (mm)	Mass of Sieve (g)	Mass retained (sieve + soil) (g)	% Retained	% Passing
4	4.75	515.7	515.7	0%	100%
10	2	490.7	491.5	0%	100%
20	0.85	412.6	434.0	3%	97%
40	0.425	381.9	416.7	5%	92%
60	0.25	366.8	409.4	6%	87%
140	0.106	342.5	784.9	59%	28%
200	0.075	338.7	419.6	11%	18%
Pan		364.0	494.0	18%	

% Passing = 100 - Σ% Retained

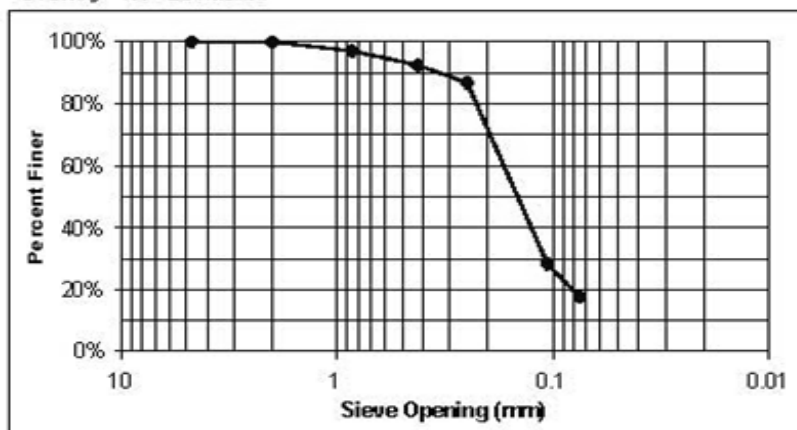

Detailed soils analysis



UNIVERSITY OF NEW MEXICO
DEPARTMENT OF CIVIL ENGINEERING

GRAIN SIZE ANALYSIS

The University of New Mexico

Urban Flood Demonstration Program
Projec

ENN (Badger N)
Boing Identification

I. Pedro & C. LeJeune
Tested By

6 10 2
Pan No. Soil Bag No. Sieve No.

January 9, 2007
Date of Testing

Brown Sand
Field Description of Soil

132.1
Mass of Dry Sample, M_s

52.5 - 54
Depth of Sample (m)

Sieve No.	Diameter (mm)	Mass of Sieve (g)	Mass retained (sieve + soil) (g)	% Retained	% Passing
4	4.75	515.7	515.7	0%	100%
10	2	490.7	494.2	3%	97%
20	0.85	412.6	422.1	7%	90%
40	0.425	381.9	389.0	5%	85%
60	0.25	366.8	372.3	4%	81%
140	0.106	342.5	401.8	45%	36%
200	0.075	338.7	360.9	17%	19%
Pan		364.0	387.2	19%	

% Passing = 100 - Σ% Retained

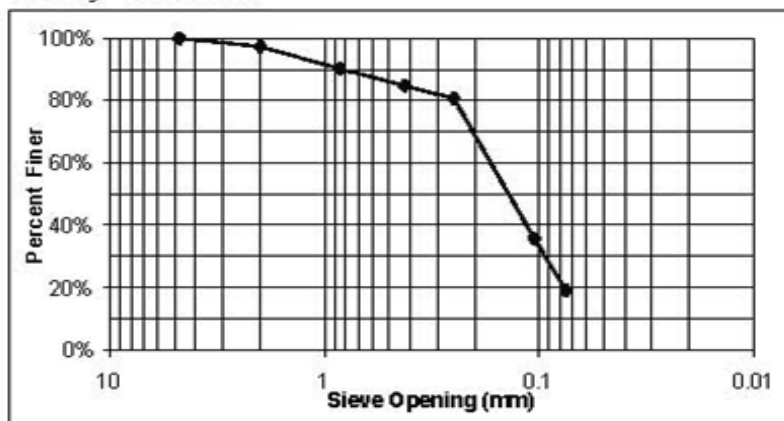

Detailed soils analysis



UNIVERSITY OF NEW MEXICO
DEPARTMENT OF CIVIL ENGINEERING

GRAIN SIZE ANALYSIS

The University of New Mexico

Urban Flood Demonstration Program
Projec

ENN (Badger N)
Boring Identification

I. Pedro & C. LeJeune
Tested By

7 11 1
Pan No. Soil Bag No. Sieve No.

January 9, 2007
Date of Testing

Dark Brown Sand
Field Description of Soil

521.4
Mass of Dry Sample, M_s

54 - 59.5
Depth of Sample (ft)

Sieve No.	Diameter (mm)	Mass of Sieve (g)	Mass retained (sieve + soil) (g)	% Retained	% Passing
4	4.75	503.2	503.2	0%	100%
10	2	464.4	464.4	0%	100%
20	0.85	413.1	416.7	1%	99%
40	0.425	370.0	377.5	1%	98%
60	0.25	354.0	367.5	3%	95%
140	0.106	342.0	598.8	49%	46%
200	0.075	327.7	444.1	22%	24%
Pan		364.0	486.9	24%	

% Passing = 100 - Σ% Retained

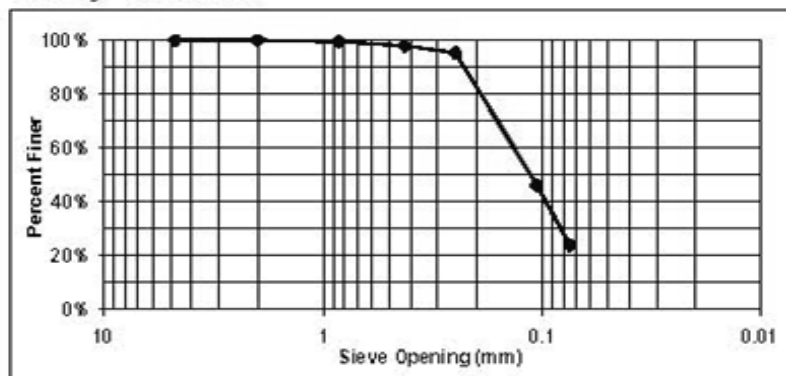

Detailed soils analysis



UNIVERSITY OF NEW MEXICO
DEPARTMENT OF CIVIL ENGINEERING

HYDROMETER ANALYSIS

The University of New Mexico

Project Urban Flood Demonstration Project		Issued by J. Pedro		Date 20-Mar-2007
Boring Identification ENN	Cylinder # 4	Depth (m) 21 - 28.5	Time 11:35 AM	Sample Wt. (g) 50.0
Specific Gravity 2.70	Mixture Content (%) 19.4	Notes Soil Bag 5, Pan 3		

MENISCUS CORRECTION (m)	0
G _s CORRECTION FACTOR (α)	0.99
SUSPENSION CONSTANT (k)	0.01344
CORRECTED SAMPLE WT. (W _s)	40.3
PERCENT PASSING #200 SIEVE	62%

Elapsed Time (min)	Hydrometer Reading		Temperature (°C)	Effective Depth (cm)		Particle Diameter (mm)	% Finer (%)
	Orig.	R _s		R _{a(Corr)}	Corrected		
2	13	13	21	14.2	14.0580	0.0356	19.8%
5	7	7	21	15.2	15.0480	0.0233	10.7%
10	7	7	21	15.2	15.0480	0.0165	10.7%
15	6	6	21	15.3	15.1470	0.0135	9.1%
20	6	6	20	15.3	15.1470	0.0117	9.1%
30	5	5	21	15.5	15.3450	0.0096	7.6%
60	5	5	20	15.5	15.3450	0.0068	7.6%
250	5	5	20	15.5	15.3450	0.0033	7.6%
1440	5	5	17	15.5	15.3450	0.0014	7.6%

Detailed soils analysis



UNIVERSITY OF NEW MEXICO
DEPARTMENT OF CIVIL ENGINEERING

HYDROMETER ANALYSIS

The University of New Mexico

Project Urban Flood Demonstration Project		Analyst By I. Pedro		Date 20-Mar-2007
Soiling Identification ENN	Cylinder # 5	Depth (cm) 36 - 41.5	Time 11:43 AM	Sample Wt. (g) 50.0
Specific Gravity 2.70	Molecular Weight (M) 25.1	Notes Soil Bag 7, Pan 4		

MENISCUS CORRECTION (m)	<u>0</u>
G _s CORRECTION FACTOR (α)	<u>0.99</u>
SUSPENSION CONSTANT (k)	<u>0.01344</u>
CORRECTED SAMPLE WT. (W _s)	<u>37.5</u>
PERCENT PASSING #200 SIEVE	<u>73%</u>

Elapsed Time (min)	Hydrometer Reading		Temperature (°C)	Effective Depth (cm)		Particle Diameter (mm)	% Finer (%)
	Orig.	R _s		R _{a(Corr)}	Corrected		
2	7	7	21	15.2	15.0480	0.0369	13.5%
5	6	6	21	15.3	15.1470	0.0234	11.6%
10	5	5	21	15.5	15.3450	0.0166	9.6%
15	5	5	21	15.5	15.3450	0.0136	9.6%
20	5	5	20	15.5	15.3450	0.0118	9.6%
30	5	5	21	15.5	15.3450	0.0096	9.6%
60	4	4	20	15.6	15.4440	0.0068	7.7%
250	4	4	20	15.6	15.4440	0.0033	7.7%
1440	4	4	18	15.6	15.4440	0.0014	7.7%

Detailed soils analysis



UNIVERSITY OF NEW MEXICO
DEPARTMENT OF CIVIL ENGINEERING

GRAIN SIZE ANALYSIS

The University of New Mexico

Urban Flood Demonstration Project
Project
I. Pedro
Tested By

ENN (Badger N)
Boring Identification
3 5
Pan No. Soil Bag

Sieve No.	Diameter (mm)	% Passing
4	4.75	100%
10	2	100%
20	0.85	100%
40	0.425	100%
60	0.25	98%
140	0.106	77%
200	0.075	62%
	0.0356	19.8%
	0.0233	10.7%
	0.0165	10.7%
	0.0135	9.1%
	0.0117	9.1%
	0.0096	7.6%
	0.0068	7.6%
	0.0033	7.6%
	0.0014	7.6%

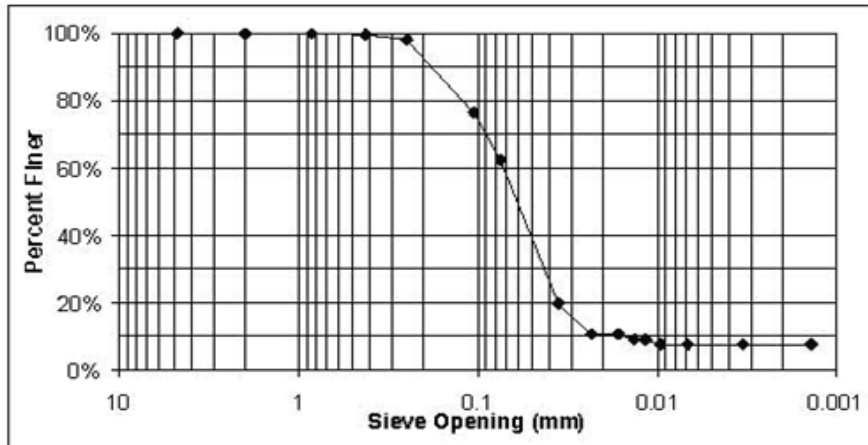

Detailed soils analysis



UNIVERSITY OF NEW MEXICO
DEPARTMENT OF CIVIL ENGINEERING

GRAIN SIZE ANALYSIS

The University of New Mexico

Urban Flood Demonstration Project
Project
I. Pedro
Tested By

ENN (Badger N)
Boring Identification
4 7
Pan No. Soil Bag

Sieve No.	Diameter (mm)	% Passing
4	4.75	100%
10	2	100%
20	0.85	99%
40	0.425	98%
60	0.25	95%
140	0.106	82%
200	0.075	73%
	0.0369	13.5%
	0.0234	11.6%
	0.0166	9.6%
	0.0136	9.6%
	0.0118	9.6%
	0.0096	9.6%
	0.0068	7.7%
	0.0033	7.7%
	0.0014	7.7%

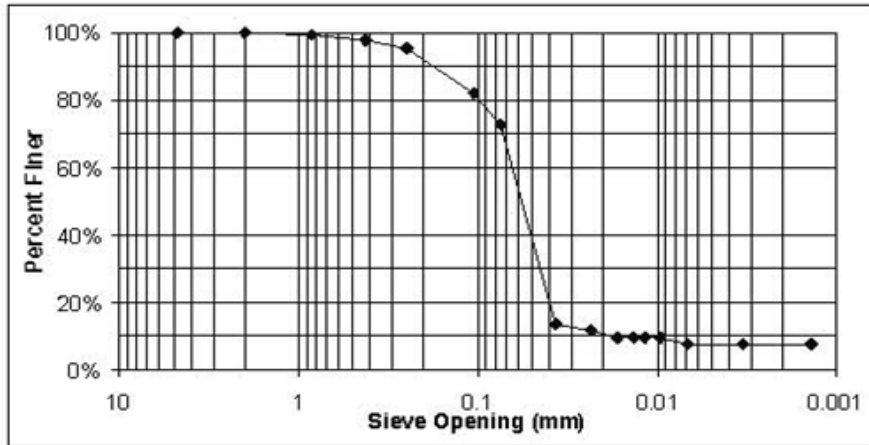

Detailed soils analysis



The University of New Mexico

UNIVERSITY OF NEW MEXICO
DEPARTMENT OF CIVIL ENGINEERING

SOIL BORING LOG INFORMATION

PAGE 1 of 1

Project Name Urban Flood Demonstration Project		Boring Classification ID ENW		Date of Drilling 14-Aug-06		Corresponding Well ID Badger (EU21) West		
Boring Drilled By: I. Pedro & C. LeJeune		Canopy Rain Gage N/A		Open Rain Gage N/A		Weather Cloudy		
Boring Location 10 Feet S of Well		# of Soil Bags Collected 12		Water Table Depth 74"		Final Depth 77.5"		
				Well Bore Depth 79.5"		Temperature 83 F		
SAMPLE		DESCRIPTION (Visual-Manual Method)						COMMENTS
DEPTH (IN)	NUMBER	MOISTURE	COLOR	DRY STRENGTH	DILATANCY	TOUGHNESS	PLASTICITY	
0	0	M	Bm					Surface covered with mulch and organic material 9" of mulch. Ground surface measured 9" below mulch.
7.5	1	M	DBm	M	S	L	M	Clayey appearance and encountered some roots
12	2	M	Brn	L	S	L	M	Encountered roots @ 11.5" and has a sandy appearance
18	3	M	LBm	N	R	L	N	Sandy appearance
24	4	M	LBm	N	R	L	N	
30.5	5	M	LBm	N	R	L	N	
36.5	6	M	LBm	N	R	L	N	
44	7	M	LBm	N	R	L	N	
50	8	M	LBm	N	R	L	N	
57.5	9	M	LBm	N	R	L	N	
64	10	M	LBm	N	R	L	N	
70	11	VM	LBm	N	R	L	N	
77.5	12	W	LBm					Water table reach @ 74". Too saturated for VMM testing.
								**Rained Night before
I hereby certify that the information of this form is true and correct to the best of my knowledge								
Signature				Print Name		Date		
				Isaiah Pedro / Christian LeJeune		14-Aug-06		

Detailed soils analysis



UNIVERSITY OF NEW MEXICO
DEPARTMENT OF CIVIL ENGINEERING

WATER CONTENT DETERMINATION

The University of New Mexico

Urban Flood Demonstration Project
Project

I. Pedro
Tested By

January 10, 2007
Date of Testing

January 11, 2007
Date of Dry Weighing

ENW (Badger WY**
Boring Identification

CONTAINER NO. (CUP)	1*	2*	3	4	5	6	
FIELD TEXTURE	Sand w/Clay	Sand w/Clay	L.B. Sand	L.B. Sand	L.B. Sand	L.B. Sand	
BORING BAG NO.	1	2	3	6	8	11	
DEPTH (ft)	9 - 16.5	16.5 - 21	21 - 27	39.5 - 45.5	53 - 59	73 - 79	
MASS OF CUP + WET SOIL (g)	718.1	629.2	912.3	901.5	1001.4	924.2	
MASS OF CUP + DRY SOIL (g)	611.0	547.1	865.2	883.7	979.5	848.7	
MASS OF CUP (g)	139.2	138.6	139.1	139.2	138.9	139.0	
MASS OF DRY SOIL, Ms (g)	471.8	408.5	726.1	744.5	840.6	709.7	
MASS OF WATER, Mw (g)	107.1	82.1	47.1	17.8	21.9	75.5	
WATER CONTENT, w (%)	22.7%	20.1%	6.5%	2.4%	2.6%	10.6%	

CONTAINER NO. (CUP)							
FIELD TEXTURE							
BORING BAG NO.							
DEPTH (ft)							
MASS OF CUP + WET SOIL (g)							
MASS OF CUP + DRY SOIL (g)							
MASS OF CUP (g)							
MASS OF DRY SOIL, Ms (g)							
MASS OF WATER, Mw (g)							
WATER CONTENT, w (%)							

$$w = \frac{M_w}{M_s} (100) \%$$

*Sample to be washed

**Encounter 9 inches of mulch at surface

Detailed soils analysis



The University of New Mexico

UNIVERSITY OF NEW MEXICO
DEPARTMENT OF CIVIL ENGINEERING

GRAIN SIZE ANALYSIS

Urban Flood Demonstration Program
Projec

ENW (Badger W)
Boing Identification

I. Pedro
Tested By

1* 1 1
Pan No. Soil Bag No. Sieve No.

January 12, 2007
Date of Testing

Sand wClay
Field Description of Soil

471.8
Mass of Dry Sample, M_s

9 - 16.5
Depth of Sample (m)

Sieve No.	Diameter (mm)	Mass of Sieve (g)	Mass retained (sieve + soil) (g)	%Washed Material	
				% Retained	% Passing
4	4.75	503.2	503.2	0%	100%
10	2	464.4	464.8	0%	100%
20	0.85	413.1	415.1	0%	99%
40	0.425	370.0	373.7	1%	99%
60	0.25	354.0	366.3	3%	96%
140	0.106	342.0	417.5	16%	80%
200	0.075	327.7	368.5	9%	71%
Pan		364.0	701.0	71%	

% Passing = 100 - % Retained

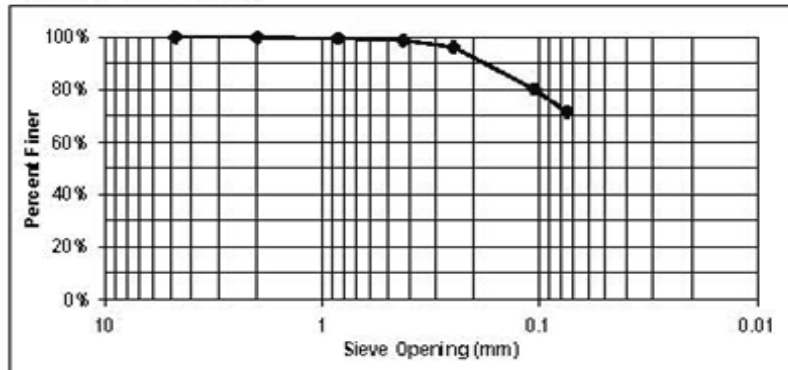

Detailed soils analysis



UNIVERSITY OF NEW MEXICO
DEPARTMENT OF CIVIL ENGINEERING

GRAIN SIZE ANALYSIS

The University of New Mexico

Urban Flood Demonstration Program
Project

ENW (Badger W)
Boiling Identification

I. Pedro
Tested By

2* 2 2
Pan No. Soil Bag No. Sieve No.

January 12, 2007
Date of Testing

Sand w/Clay
Field Description of Soil

408.5
Mass of Dry Sample, M_s

16.5 - 21
Depth of Sample (in)

Sieve No.	Diameter (mm)	Mass of Sieve (g)	Mass retained (sieve + soil) (g)	% Retained	% Passing
4	4.75	515.7	516.2	0%	100%
10	2	490.7	490.9	0%	100%
20	0.85	412.6	412.9	0%	100%
40	0.425	381.9	382.5	0%	100%
60	0.25	366.8	373.2	2%	98%
140	0.106	342.5	419.3	19%	79%
200	0.075	338.7	394.4	14%	66%
Pan		364.0	631.7	66%	

*Washed Material

% Passing = 100 - Σ% Retained

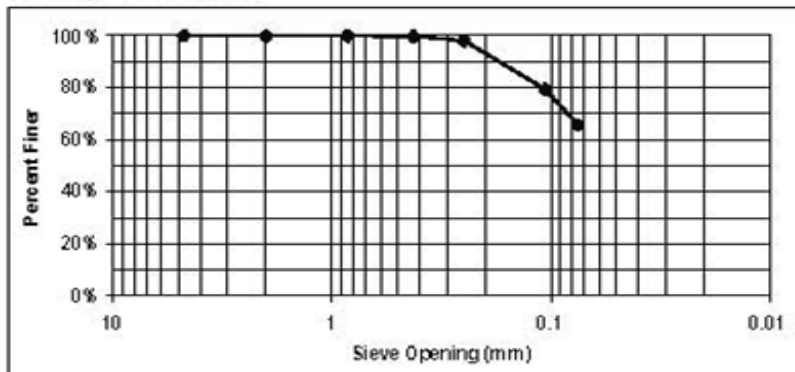

Detailed soils analysis



The University of New Mexico

UNIVERSITY OF NEW MEXICO
DEPARTMENT OF CIVIL ENGINEERING

GRAIN SIZE ANALYSIS

Urban Flood Demonstration Program
Projec

ENW (Badger W)
Boing Identification

I. Pedro
Tested By

3 3 1
Pan No. Soil Bag No. Sieve No.

January 11, 2007
Date of Testing

Light Brown Sand
Field Description of Soil

726.1
Mass of Dry Sample, M_s

21 - 27
Depth of Sample (m)

Sieve No.	Diameter (mm)	Mass of Sieve (g)	Mass retained (sieve + soil) (g)	% Retained	% Passing
4	4.75	503.2	516.0	2%	98%
10	2	464.4	501.8	5%	93%
20	0.85	413.1	449.0	5%	88%
40	0.425	370.0	398.4	4%	84%
60	0.25	354.0	485.7	18%	66%
140	0.106	342.0	765.2	58%	8%
200	0.075	327.7	356.0	4%	4%
Pan		364.0	393.5	4%	

% Passing = 100 - Σ% Retained

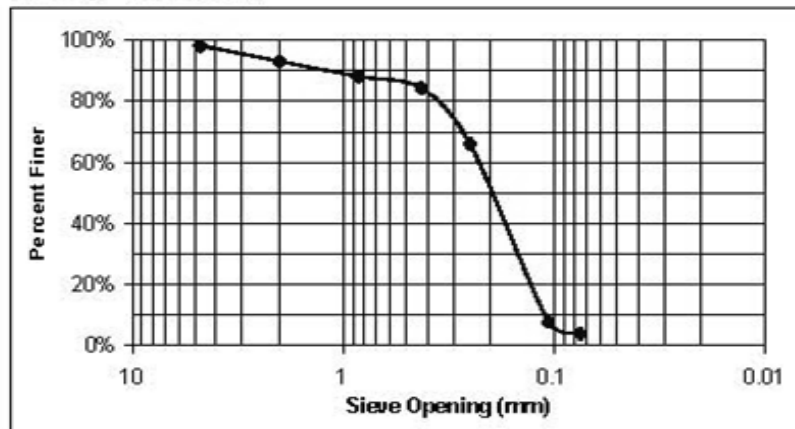

Detailed soils analysis



The University of New Mexico

UNIVERSITY OF NEW MEXICO
DEPARTMENT OF CIVIL ENGINEERING

GRAIN SIZE ANALYSIS

Urban Flood Demonstration Program
Project

ENW (Badger W)
Boring Identification

I. Pedro
Tested By

4 6 2
Pan No. Soil Bag No. Sieve No.

January 11, 2007
Date of Testing

Light Brown Sand
Field Description of Soil

744.5
Mass of Dry Sample, M_s

39.5 - 45.5
Depth of Sample (ft)

Sieve No.	Diameter (mm)	Mass of Sieve (g)	Mass retained (sieve + soil) (g)	% Retained	% Passing
4	4.75	515.7	515.7	0%	100%
10	2	490.7	493.2	0%	100%
20	0.85	412.6	418.5	1%	99%
40	0.425	381.9	420.5	5%	94%
60	0.25	366.8	602.1	32%	62%
140	0.106	342.5	781.9	59%	3%
200	0.075	338.7	354.5	2%	1%
Pan		364.0	370.9	1%	

% Passing = 100 - % Retained

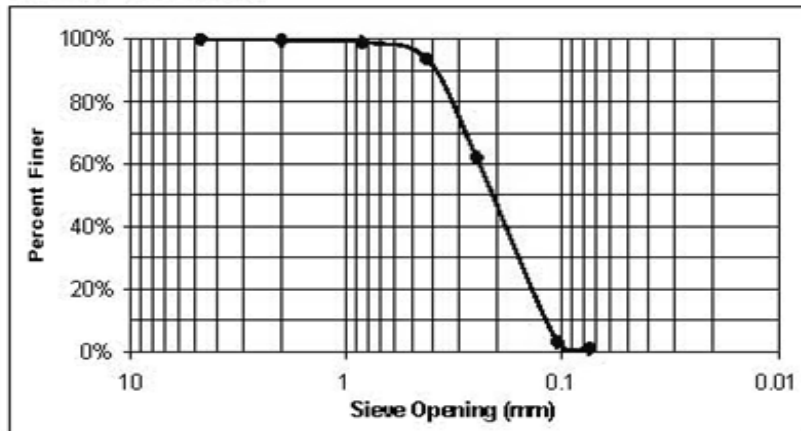

Detailed soils analysis



The University of New Mexico

UNIVERSITY OF NEW MEXICO
DEPARTMENT OF CIVIL ENGINEERING

GRAIN SIZE ANALYSIS

Urban Flood Demonstration Program
Projec

ENW (Badger W)
Boing Identification

I. Pedro
Tested By

5 8 1
Pan No. Soil Bag No. Sieve No.

January 11, 2007
Date of Testing

Light Brown Sand
Field Description of Soil

840.6
Mass of Dry Sample, M_s

53 - 59
Depth of Sample (in)

Sieve No.	Diameter (mm)	Mass of Sieve (g)	Mass retained (sieve + soil) (g)	% Retained	% Passing
4	4.75	503.2	504.4	0%	100%
10	2	464.4	468.0	0%	99%
20	0.85	413.1	418.8	1%	99%
40	0.425	370.0	414.6	5%	93%
60	0.25	354.0	700.1	41%	52%
140	0.106	342.0	761.1	50%	2%
200	0.075	327.7	340.6	2%	1%
Pan		364.0	371.4	1%	

% Passing = 100 - % Retained

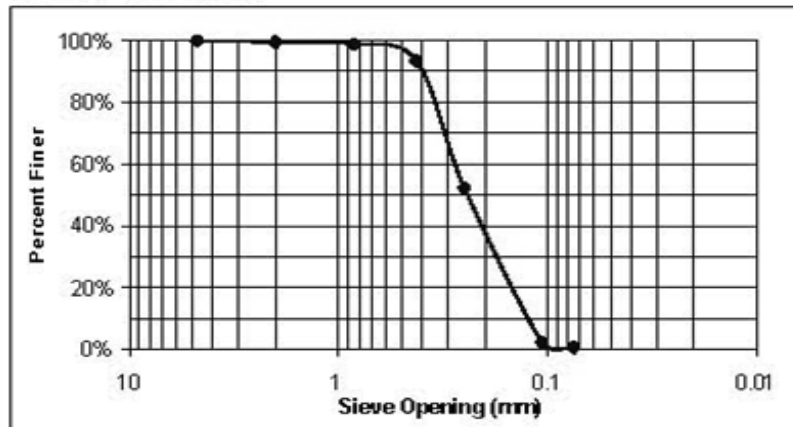

Detailed soils analysis



The University of New Mexico

UNIVERSITY OF NEW MEXICO
DEPARTMENT OF CIVIL ENGINEERING

GRAIN SIZE ANALYSIS

Urban Flood Demonstration Program

ENW (Badger W)

Projec

Boing Identification

I. Pedro

6 11 2

Tested By

Pan No. Soil Bag No. Sieve No.

January 11, 2007

Light Brown Sand

Date of Testing

Field Description of Soil

709.7

73 - 79

Mass of Dry Sample, M_s

Depth of Sample (n)

Sieve No.	Diameter (mm)	Mass of Sieve (g)	Mass retained (sieve + soil) (g)	% Retained	% Passing
4	4.75	515.7	517.4	0%	100%
10	2	490.7	496.7	1%	99%
20	0.85	412.6	436.7	3%	96%
40	0.425	381.9	543.8	23%	73%
60	0.25	366.8	686.3	45%	28%
140	0.106	342.5	528.1	26%	2%
200	0.075	338.7	343.9	1%	1%
Pan		364.0	368.7	1%	

% Passing = 100 - Σ% Retained

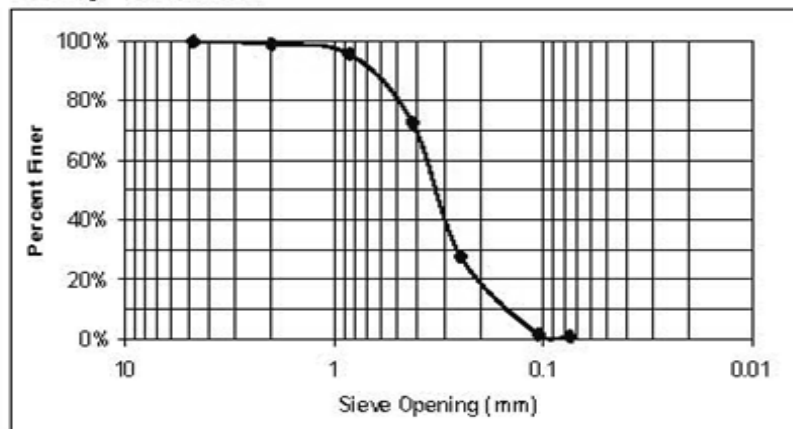

Detailed soils analysis



UNIVERSITY OF NEW MEXICO
DEPARTMENT OF CIVIL ENGINEERING

HYDROMETER ANALYSIS

The University of New Mexico

Project Urban Flood Demonstration Project		Analyst By J. Pedro		Date 27-Mar-2007
Boring Identification ENW	Cylinder # 4	Depth (ft) 9-16.5	Time 1:18 PM	Sample Wt. (g) 50.0
Specific Gravity 2.70	Moisture Content (%) 22.7	Notes Soil Bag 1, Pan 1		

MENISCUS CORRECTION (m) 1
 G_s CORRECTION FACTOR (α) 0.99
 SUSPENSION CONSTANT (k) 0.01361
 CORRECTED SAMPLE WT. (W_s) 38.7
 PERCENT PASSING #200 SIEVE 71%

Elapsed Time (min)	Hydrometer Reading		Temperature (°C)	Effective Depth (cm)		Particle Diameter (mm)	% Finer (%)
	Orig.	R_s		$R_{s(Comp)}$	Corrected		
2	24	23	19	12.5	12.3750	0.0339	41.8%
5	18	17	19	13.5	13.3650	0.0223	30.9%
10	15	14	19	14.0	13.8600	0.0160	25.5%
15	14	13	19	14.2	14.0680	0.0132	23.6%
20	14	13	19	14.2	14.0680	0.0114	23.6%
30	14	13	19	14.2	14.0680	0.0093	23.6%
60	13	12	20	14.3	14.1570	0.0066	21.8%
250	13	12	19	14.3	14.1570	0.0032	21.8%
1440	12	11	18	14.5	14.3550	0.0014	20.0%

Detailed soils analysis



UNIVERSITY OF NEW MEXICO
DEPARTMENT OF CIVIL ENGINEERING

HYDROMETER ANALYSIS

The University of New Mexico

Project Urban Flood Demonstration Project		Issued By J. Pedro		Date 27-Mar-2007
Soiling Identification ENV	Cylinder # 5	Depth (m) 16.5 - 21	Time 1:30 PM	Sample Wt (g) 50.0
Specific Gravity 2.70	Mixture Content (%) 20.1	Notes Soil Bag 2, Pan 2		

MENISCUS CORRECTION (m)	<u>1</u>
G _s CORRECTION FACTOR (α)	<u>0.99</u>
SUSPENSION CONSTANT (k)	<u>0.01361</u>
CORRECTED SAMPLE WT. (V _s)	<u>40.0</u>
PERCENT PASSING #200 SIEVE	<u>66%</u>

Elapsed Time (min)	Hydrometer Reading		Temperature (°C)	Effective Depth (cm)		Particle Diameter (mm)	% Finer (%)
	Orig.	R _s		R _s (Corr)	Corrected		
2	23	22	19	12.7	12.5730	0.0341	36.0%
5	17	16	19	13.7	13.5630	0.0224	26.2%
10	16	15	20	13.8	13.6620	0.0159	24.5%
15	15	14	20	14.0	13.8600	0.0131	22.9%
20	15	14	19	14.0	13.8600	0.0113	22.9%
30	15	14	20	14.0	13.8600	0.0093	22.9%
60	15	14	21	14.0	13.8600	0.0065	22.9%
250	14	13	19	14.2	14.0680	0.0032	21.3%
1440	14	13	18	14.2	14.0680	0.0013	21.3%

Detailed soils analysis



UNIVERSITY OF NEW MEXICO
DEPARTMENT OF CIVIL ENGINEERING

GRAIN SIZE ANALYSIS

The University of New Mexico

Urban Flood Demonstration Project
Project
I. Pedro
Tested By

ENW (Badger W)
Boring Identification
1 1
Pan No. Soil Bag

Sieve No.	Diameter (mm)	% Passing
4	4.75	100%
10	2	100%
20	0.85	99%
40	0.425	99%
60	0.25	96%
140	0.106	80%
200	0.075	71%
	0.0339	41.8%
	0.0223	30.9%
	0.0160	25.5%
	0.0132	23.6%
	0.0114	23.6%
	0.0093	23.6%
	0.0066	21.8%
	0.0032	21.8%
	0.0014	20.0%

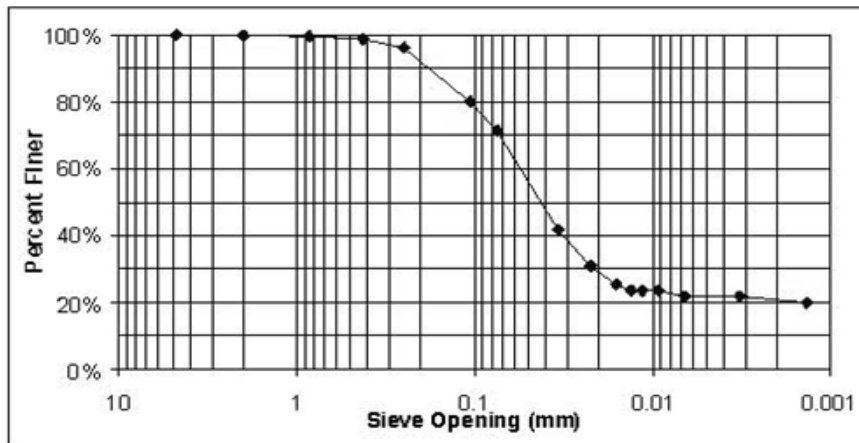

Detailed soils analysis



UNIVERSITY OF NEW MEXICO
DEPARTMENT OF CIVIL ENGINEERING

GRAIN SIZE ANALYSIS

The University of New Mexico

Urban Flood Demonstration Project
Project
I. Pedro
Tested By

ENW (Badger W)
Boring Identification
2 2
Pan No. Soil Bag

Sieve No.	Diameter (mm)	% Passing
4	4.75	100%
10	2	100%
20	0.85	100%
40	0.425	100%
60	0.25	98%
140	0.106	79%
200	0.075	66%
	0.0341	36.0%
	0.0224	26.2%
	0.0159	24.5%
	0.0131	22.9%
	0.0113	22.9%
	0.0093	22.9%
	0.0065	22.9%
	0.0032	21.3%
	0.0013	21.3%

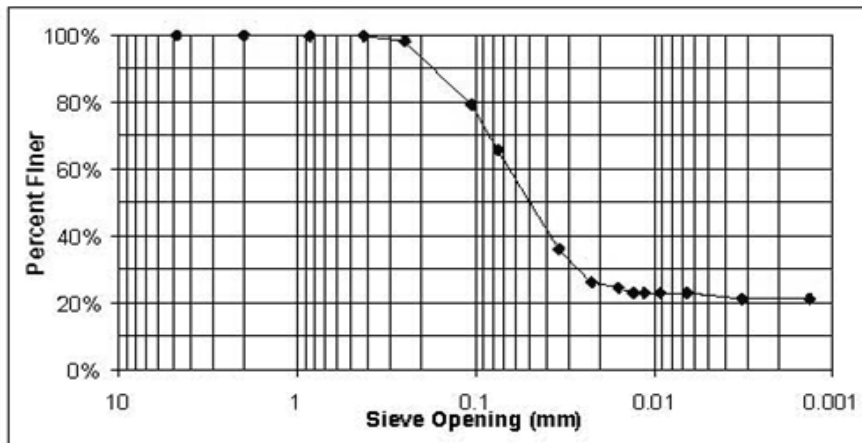

Detailed soils analysis



UNIVERSITY OF NEW MEXICO
DEPARTMENT OF CIVIL ENGINEERING

SOIL BORING LOG INFORMATION

PAGE 1 of 2

The University of New Mexico

Project Name Urban Flood Demonstration Project		Boring Classification ID ENS		Date of Drilling 14-Aug-06		Corresponding Well ID Badger (EU21) South		
Boring Drilled By I. Pedro & C. LeJeune		Canopy Rain Gage N/A		Open Rain Gage N/A		Weather Cloudy		
Boring Location 9 Feet W of Well		# of Soil Bags Collected 28		Water Table Depth 117.5"		Final Depth 122.5"		
				Well Borer Depth 119"		Tempera Lire 76 F		
SAMPLE	DESCRIPTION (Visual-Manual Method)							COMMENTS
DEPTH (ft)	NUMBER	MOISTURE	COLOR	DRY STRENGTH	DILATANCY	TOUGHNESS	PLASTICITY	
0	0	M	DBm					Organic material, twigs and leaves present
2	1	M	DBm	M	S	M	M	Organic material present with a sandy appearance
6	2	M	Bm	M	N	L	M	Organic material present
12	3	M	Brn	L	M	L	L	
15	4	M	Bm	L	S	L	M	
17	5	M	Bm	M	S	M	M	Sandy clay appearance. Sample material came out clumpy
22	6	M	Bm	M	S	M	M	
24	7	M	Bm	H	N	M	M	
26	8	M	Bm	M	N	M	L	Sandy appearance
30	9	M	Brn	M	N	L	L	Sandy clayey appearance with organic material present Soil sample material came out clumpy
35	10	M	Brn	M	S	M	M	
38	11	M	Brn	M	N	M	M	
40.5	12	M	Tan	M	S	M	M	
45.5	13	M	Tan	M	S	M	M	
51	14	M	Brn	H	S	M	M	
53	15	M	Bm	H	S	M	M	
56.5	16	M	Tan	M	S	M	M	
62	17	M	Tan	L	R	L	N	
I hereby certify that the information of this form is true and correct to the best of my knowledge.								
Signature				Print Name				Date
				Isaiah Pedro / Christian LeJeune				14-Aug-06

Detailed soils analysis



UNIVERSITY OF NEW MEXICO
DEPARTMENT OF CIVIL ENGINEERING

WATER CONTENT DETERMINATION

The University of New Mexico

Urban Flood Demonstration Project
Project

I. Pedro
Tested By

November 28, 2006
Date of Testing

November 29, 2006
Date of Dry Weighing

ENS (Badger S)
Boring Identification

CONTAINER NO. (CUP)	1	2	3*	4*	5	6	7
FIELD TEXTURE	OM	B. Sand	Sand w/Clay	B. Sand	B. Sand	B. Sand	L.B. Sand
BORING BAG NO.	1	3	6	9	13	15	16
DEPTH (in)	0 - 2	6 - 12	17 - 22	26 - 30	40.5 - 45.5	51 - 53	53 - 56.5
MASS OF CUP + WET SOIL (g)	343.2	643.6	558.0	545.8	504.2	476.7	376.3
MASS OF CUP + DRY SOIL (g)	306.8	583.2	476.8	468.5	464.9	415.1	352.3
MASS OF CUP (g)	139.2	138.6	139.1	139.2	138.9	139.0	137.8
MASS OF DRY SOIL, Ms (g)	167.6	444.6	337.7	329.3	326.0	276.1	214.5
MASS OF WATER, Mw (g)	36.4	60.4	81.2	77.3	39.3	61.6	24.0
WATER CONTENT, w (%)	21.7%	13.6%	24.0%	23.5%	12.1%	22.3%	11.2%

CONTAINER NO. (CUP)	8	9*	10	11			
FIELD TEXTURE	L.B. Sand	L.B. Sand	B. Sand	B. Sand			
BORING BAG NO.	20	23	24	27			
DEPTH (in)	71.5 - 76.5	88 - 93	93 - 99.5	111 - 116			
MASS OF CUP + WET SOIL (g)	681.7	760.0	746.7	753.7			
MASS OF CUP + DRY SOIL (g)	667.4	741.6	716.9	720.5			
MASS OF CUP (g)	138.0	139.4	139.4	137.6			
MASS OF DRY SOIL, Ms (g)	529.4	602.2	577.5	582.9			
MASS OF WATER, Mw (g)	14.3	18.4	29.8	33.2			
WATER CONTENT, w (%)	2.7%	3.1%	5.2%	5.7%			

$$w = \frac{M_w}{M_s} (100) \%$$

*Sample to be washed

Detailed soils analysis



The University of New Mexico

UNIVERSITY OF NEW MEXICO
DEPARTMENT OF CIVIL ENGINEERING

GRAIN SIZE ANALYSIS

Urban Flood Demonstration Project
Projec

ENS (Badger S)
Boring Identification

L. Pedro
Tested By

1 1 1
Pan No. Soil Bag No. Sieve Set

November 29, 2006
Date of Testing

OM
Field Description of Soil

167.6
Mass of Dry Sample (g), M

0 - 2
Depth of Sample (m)

Sieve No.	Diameter (mm)	Mass of Sieve (g)	Mass retained (sieve + soil) (g)	% Retained	% Passing
4	4.75	503.2	504.9	1%	99%
10	2	464.4	464.9	0%	99%
20	0.85	413.1	442.5	18%	81%
40	0.425	370	406.5	22%	59%
60	0.25	354	372.9	11%	48%
140	0.106	342	369.2	16%	32%
200	0.075	327.7	340.3	8%	24%
Pan		364	404.8	24%	

% Passing = 100 - % Retained

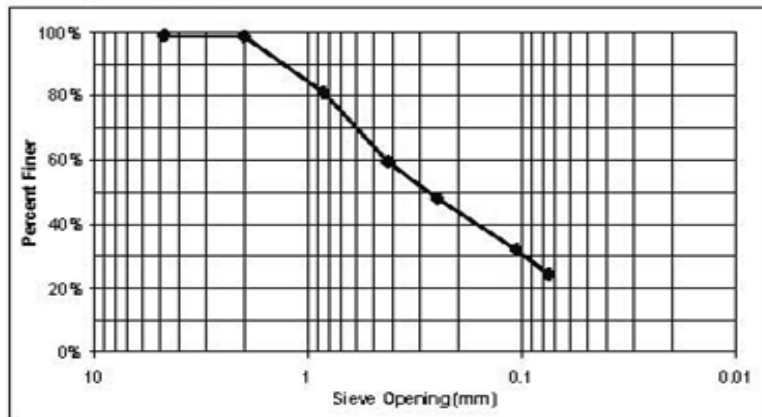

Detailed soils analysis



The University of New Mexico

UNIVERSITY OF NEW MEXICO
DEPARTMENT OF CIVIL ENGINEERING

GRAIN SIZE ANALYSIS

Urban Flood Demonstration Project
Project

ENS (Badger S)
Boring Identification

L. Pedro
Tested By

2 Pan No. 3 Soil Bag No. 2 Sieve Set

November 29, 2006
Date of Testing

Brown Sand
Field Description of Soil

444.6
Mass of Dry Sample (g), M_s

6-12
Depth of Sample (m)

Sieve No.	Diameter (mm)	Mass of Sieve (g)	Mass retained (sieve + soil) (g)	% Retained	% Passing
4	4.75	515.7	516	0%	100%
10	2	490.7	503.4	3%	97%
20	0.85	412.6	440.1	6%	91%
40	0.425	381.9	406.2	5%	85%
60	0.25	366.8	385.9	4%	81%
140	0.106	342.5	424.9	19%	63%
200	0.075	338.7	400.9	14%	49%
Pan		364	579.6	49%	

% Passing = 100 - % Retained

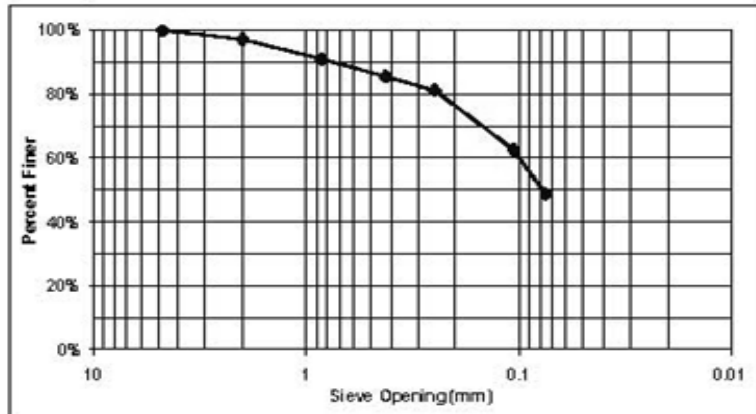

Detailed soils analysis



UNIVERSITY OF NEW MEXICO
DEPARTMENT OF CIVIL ENGINEERING

GRAIN SIZE ANALYSIS

Urban Flood Demonstration Project
Project

ENS (Badger S)
Boring Identification

I. Pedro
Tested By

3rd Pan No. 6 Soil Bag No. 1 Sieve Set

November 29, 2006
Date of Testing

Sand w/Clay
Field Description of Soil

186.6
Mass of Dry Sample (g), M_s

17 - 22
Depth of Sample (ft)

*Non-Washed Material

Sieve No.	Diameter (mm)	Mass of Sieve (g)	Mass retained (sieve + soil) (g)	% Retained	% Passing
4	4.75	503.2	503.3	0%	100%
10	2	464.4	464.4	0%	100%
20	0.85	413.1	431.1	10%	90%
40	0.425	370	394.6	13%	77%
60	0.25	354	371.4	9%	68%
140	0.106	342	368.7	14%	53%
200	0.075	327.7	341.2	7%	46%
Pan		364	450.3	46%	

% Passing = 100 - % Retained

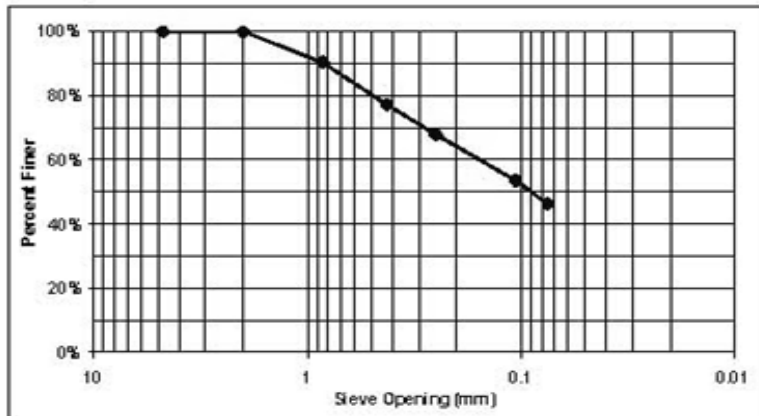

Detailed soils analysis



UNIVERSITY OF NEW MEXICO
DEPARTMENT OF CIVIL ENGINEERING

GRAIN SIZE ANALYSIS

Urban Flood Demonstration Project
Projec

ENS (Badger S)
Boring Identification

I. Pedro
Tested By

3** 6 1
Pan No. Soil Bag No. Sieve Set

November 30, 2006
Date of Testing

Sand w/Clay
Field Description of Soil

151.1
Mass of Dry Sample (g), M

17 - 22
Depth of Sample (n)

**Washed Material

Sieve No.	Diameter (mm)	Mass of Sieve (g)	Mass retained (sieve + soil) (g)	% Retained	% Passing
4	4.75	503.2	503.6	0%	100%
10	2	464.4	465.7	1%	99%
20	0.85	413.1	422.1	6%	93%
40	0.425	370	380.8	7%	86%
60	0.25	354	363.9	7%	79%
140	0.106	342	357.4	10%	69%
200	0.075	327.7	332.5	3%	66%
Pan		364	464.8	66%	

% Passing = 100 - % Retained

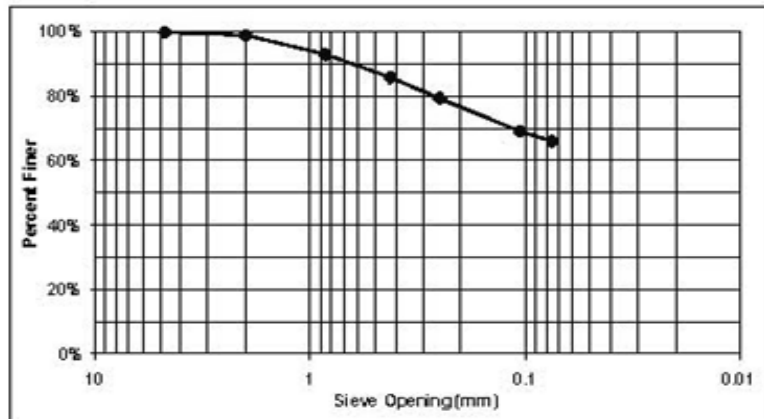

Detailed soils analysis



UNIVERSITY OF NEW MEXICO
DEPARTMENT OF CIVIL ENGINEERING

GRAIN SIZE ANALYSIS

Urban Flood Demonstration Project
Project

ENS (Badger S)
Boring Identification

I. Pedro & C. LeJeune
Tested By

4 Pan No. 9 Soil Bag No. 2 Sieve Set

November 29, 2006
Date of Testing

Brown Sand
Field Description of Soil

180.5
Mass of Dry Sample (g), M

26 - 30
Depth of Sample (m)

*Non-Washed Material

Sieve No.	Diameter (mm)	Mass of Sieve (g)	Mass retained (sieve + soil) (g)	% Retained	% Passing
4	4.75	515.7	515.7	0%	100%
10	2	490.7	490.7	0%	100%
20	0.85	412.6	459.1	26%	74%
40	0.425	381.9	424.6	24%	51%
60	0.25	366.8	390.6	13%	37%
140	0.106	342.5	367	14%	24%
200	0.075	338.7	345.6	4%	20%
Pan		364	399.8	20%	

% Passing = 100 - % Retained

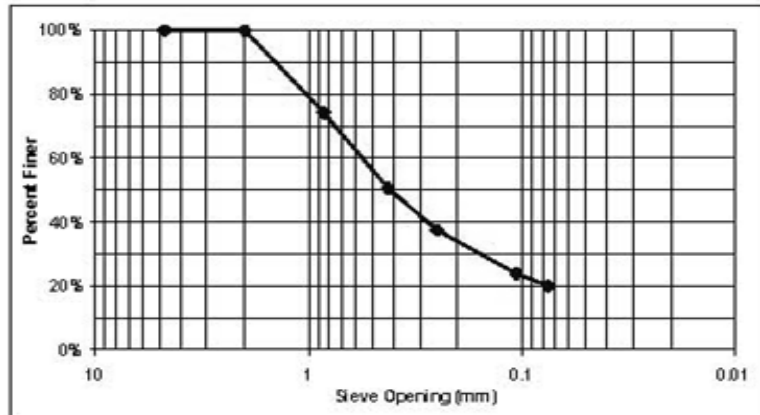

Detailed soils analysis



UNIVERSITY OF NEW MEXICO
DEPARTMENT OF CIVIL ENGINEERING

GRAIN SIZE ANALYSIS

Urban Flood Demonstration Project
Project

ENS (Badger S)
Boring Identification

I. Pedro
Tested By

4 9 2
Pan No. Soil Bag No. Sieve Set

November 30, 2006
Date of Testing

Brown Sand
Field Description of Soil

148.8
Mass of Dry Sample (g), M

26 - 30
Depth of Sample (ft)

**Washed Material

Sieve No.	Diameter (mm)	Mass of Sieve (g)	Mass retained (sieve + soil) (g)	% Retained	% Passing
4	4.75	515.7	515.7	0%	100%
10	2	490.7	495.2	3%	97%
20	0.85	412.6	430.5	12%	85%
40	0.425	381.9	398.5	11%	74%
60	0.25	366.8	379.7	9%	65%
140	0.106	342.5	355.5	9%	56%
200	0.075	338.7	341.2	2%	55%
Pan		364	445.3	55%	

% Passing = 100 - % Retained

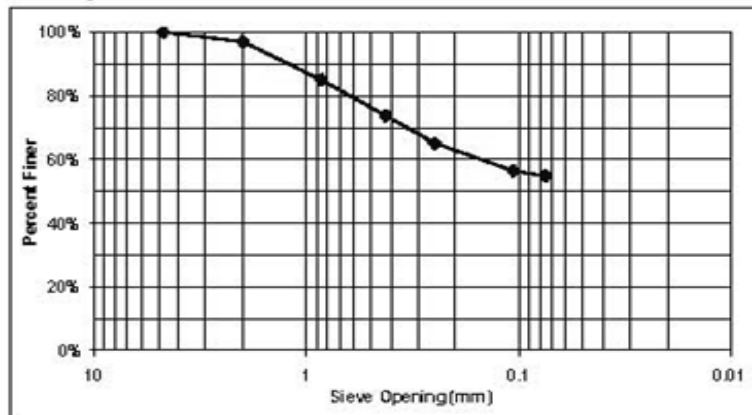

Detailed soils analysis



The University of New Mexico

UNIVERSITY OF NEW MEXICO
DEPARTMENT OF CIVIL ENGINEERING

GRAIN SIZE ANALYSIS

Urban Flood Demonstration Project
Projec

ENS (Badger S)
Boring Identification

L. Pedro
Tested By

5 13 1
Pan No. Soil Bag No. Sieve Set

November 29, 2006
Date of Testing

Brown Sand
Field Description of Soil

326
Mass of Dry Sample (g), M

40.5 - 45.5
Depth of Sample (n)

Sieve No.	Diameter (mm)	Mass of Sieve (g)	Mass retained (sieve + soil) (g)	% Retained	% Passing
4	4.75	503.2	503.3	0%	100%
10	2	464.4	471.1	2%	98%
20	0.85	413.1	460.1	14%	83%
40	0.425	370	410.7	12%	71%
60	0.25	354	376.5	7%	64%
140	0.106	342	376.7	11%	53%
200	0.075	327.7	363.3	11%	43%
Pan		364	502.9	43%	

% Passing = 100 - % Retained



Detailed soils analysis



UNIVERSITY OF NEW MEXICO
DEPARTMENT OF CIVIL ENGINEERING

GRAIN SIZE ANALYSIS

Urban Flood Demonstration Project
Project

ENS (Badger S)
Boring Identification

I. Pedro
Tested By

6 15 2
Pan No. Soil Bag No. Sieve Set

November 29, 2006
Date of Testing

Brown Sand
Field Description of Soil

276.1
Mass of Dry Sample (g), M

51 - 53
Depth of Sample (n)

Sieve No.	Diameter (mm)	Mass of Sieve (g)	Mass retained (sieve + soil) (g)	% Retained	% Passing
4	4.75	515.7	515.7	0%	100%
10	2	490.7	515.6	9%	91%
20	0.85	412.6	486.5	27%	64%
40	0.425	381.9	430.4	18%	47%
60	0.25	366.8	395.6	10%	36%
140	0.106	342.5	379.2	13%	23%
200	0.075	338.7	349.3	4%	19%
Pan		364	415.8	19%	

% Passing = 100 - % Retained

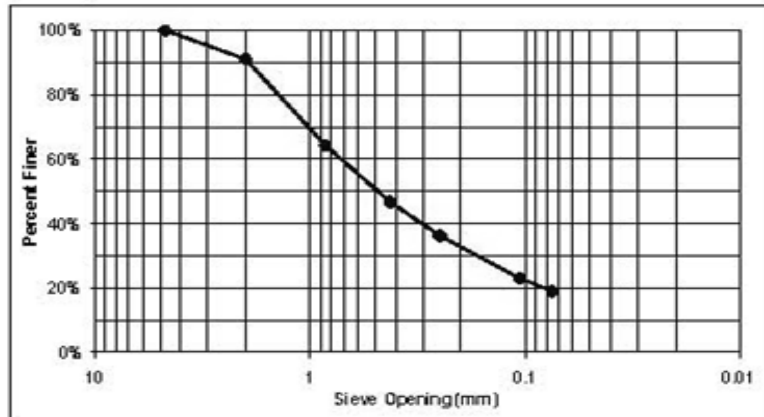

Detailed soils analysis



UNIVERSITY OF NEW MEXICO
DEPARTMENT OF CIVIL ENGINEERING

GRAIN SIZE ANALYSIS

Urban Flood Demonstration Project
Projec

ENS (Badger S)
Boring Identification

I. Pedro
Tested By

7 Pan No. 16 Soil Bag No. 1 Sieve Set

November 29, 2006
Date of Testing

Light Brown Sand
Field Description of Soil

214.5
Mass of Dry Sample (g), M

53 - 56.5
Depth of Sample (n)

Sieve No.	Diameter (mm)	Mass of Sieve (g)	Mass retained (sieve + soil) (g)	% Retained	% Passing
4	4.75	503.2	503.6	0%	100%
10	2	464.4	472.7	4%	96%
20	0.85	413.1	443.4	14%	82%
40	0.425	370	394.2	11%	71%
60	0.25	354	379.1	12%	59%
140	0.106	342	422.1	37%	21%
200	0.075	327.7	343	7%	14%
Pan		364	396.5	14%	

% Passing = 100 - % Retained



Detailed soils analysis



The University of New Mexico

UNIVERSITY OF NEW MEXICO
DEPARTMENT OF CIVIL ENGINEERING

GRAIN SIZE ANALYSIS

Urban Flood Demonstration Project
Projec

ENS (Badger S)
Boring Identification

I. Pedro
Tested By

8 Pan No. 20 Soil Bag No. 2 Sieve Set

November 29, 2006
Date of Testing

Light Brown Sand
Field Description of Soil

529.4
Mass of Dry Sample (g), M

71.5 - 76.5
Depth of Sample (m)

Sieve No.	Diameter (mm)	Mass of Sieve (g)	Mass retained (sieve + soil) (g)	% Retained	% Passing
4	4.75	515.7	519.7	1%	99%
10	2	490.7	501.1	2%	97%
20	0.85	412.6	428.7	3%	94%
40	0.425	381.9	428.9	9%	85%
60	0.25	366.8	472.8	20%	65%
140	0.106	342.5	641.9	57%	9%
200	0.075	338.7	371.9	6%	3%
Pan		364	377.3	3%	

% Passing = 100 - % Retained

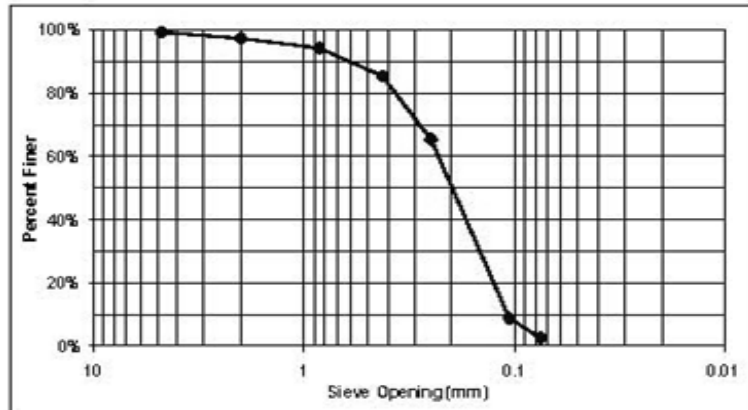

Detailed soils analysis



UNIVERSITY OF NEW MEXICO
DEPARTMENT OF CIVIL ENGINEERING

GRAIN SIZE ANALYSIS

Urban Flood Demonstration Project
Project

ENS (Badger S)
Boring Identification

I. Pedro
Tested By

9^o 23 1
Pan No. Soil Bag No. Sieve Set

November 29, 2006
Date of Testing

Light Brown Sand
Field Description of Soil

365.2
Mass of Dry Sample (g), M_s

88 - 93
Depth of Sample (m)

*Non-Washed Material

Sieve No.	Diameter (mm)	Mass of Sieve (g)	Mass retained (sieve + soil) (g)	% Retained	% Passing
4	4.75	503.2	505.2	1%	99%
10	2	464.4	468.3	1%	98%
20	0.85	413.1	426.6	4%	95%
40	0.425	370	442.7	20%	75%
60	0.25	354	497.5	39%	35%
140	0.106	342	455.2	31%	4%
200	0.075	327.7	340.1	3%	1%
Pan		364	368.3	1%	

% Passing = 100 - % Retained

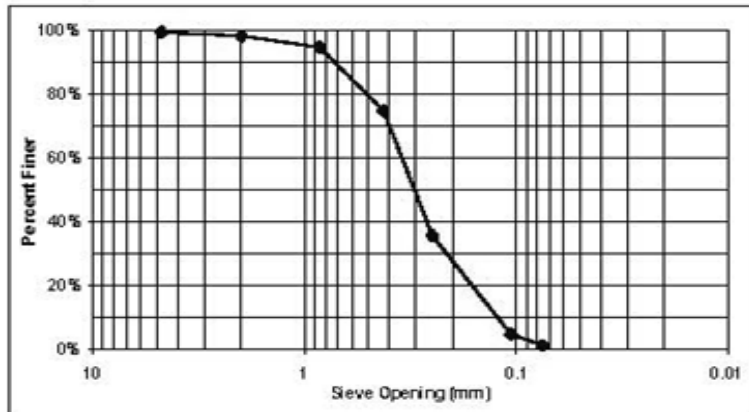

Detailed soils analysis



UNIVERSITY OF NEW MEXICO
DEPARTMENT OF CIVIL ENGINEERING

GRAIN SIZE ANALYSIS

Urban Flood Demonstration Project
Project

ENS (Badger S)
Boring Identification

I. Pedro
Tested By

9**
Pan No.

23
Soil Bag No.

1
Sieve Set

November 30, 2006
Date of Testing

Light Brown Sand
Field Description of Soil

237
Mass of Dry Sample (g), M

88 - 93
Depth of Sample (ft)

**Washed Material

Sieve No.	Diameter (mm)	Mass of Sieve (g)	Mass retained (sieve + soil) (g)	% Retained	% Passing
4	4.75	503.2	504	0%	100%
10	2	464.4	467.1	1%	99%
20	0.85	413.1	423.1	4%	94%
40	0.425	370	425.1	23%	71%
60	0.25	354	453.7	42%	29%
140	0.106	342	401.6	25%	4%
200	0.075	327.7	332.8	2%	2%
Pan		364	367.7	2%	

% Passing = 100 - % Retained

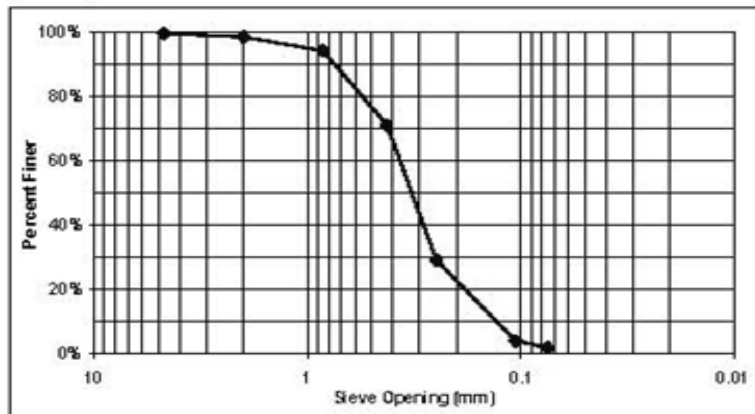

Detailed soils analysis



The University of New Mexico

UNIVERSITY OF NEW MEXICO
DEPARTMENT OF CIVIL ENGINEERING

GRAIN SIZE ANALYSIS

Urban Flood Demonstration Project
Projec

ENS (Badger S)
Boring Identification

I. Pedro
Tested By

10 24 2
Pan No. Soil Bag No. Sieve Set

November 29, 2006
Date of Testing

Brown Sand
Field Description of Soil

577.5
Mass of Dry Sample (g), M

93 - 99.5
Depth of Sample (ft)

Sieve No.	Diameter (mm)	Mass of Sieve (g)	Mass retained (sieve + soil) (g)	% Retained	% Passing
4	4.75	515.7	525	2%	98%
10	2	490.7	529.8	7%	92%
20	0.85	412.6	497.1	15%	77%
40	0.425	381.9	524.6	25%	52%
60	0.25	366.8	486.8	21%	31%
140	0.106	342.5	498.4	27%	5%
200	0.075	338.7	357.7	3%	1%
Pan		364	371.2	1%	

% Passing = 100 - % Retained

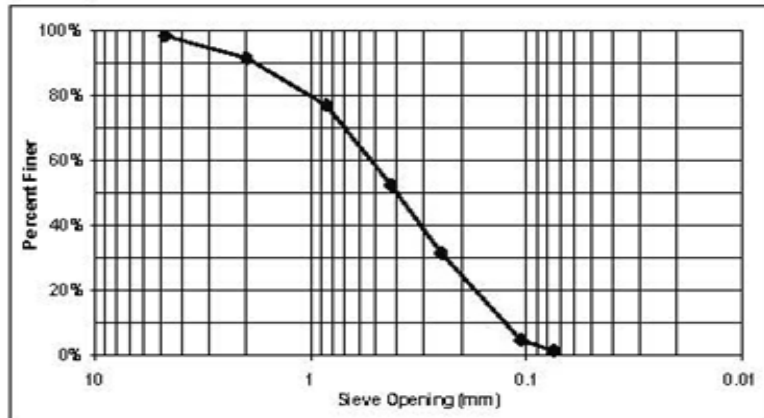

Detailed soils analysis



UNIVERSITY OF NEW MEXICO
DEPARTMENT OF CIVIL ENGINEERING

GRAIN SIZE ANALYSIS

Urban Flood Demonstration Project
Project

ENS (Badger S)
Boring Identification

I. Pedro
Tested By

11 27 1
Pan No. Soil Bag No. Sieve Set

November 29, 2006
Date of Testing

Brown Sand
Field Description of Soil

582.9
Mass of Dry Sample (g), M_s

111 - 116
Depth of Sample (in)

Sieve No.	Diameter (mm)	Mass of Sieve (g)	Mass retained (sieve + soil) (g)	% Retained	% Passing
4	4.75	503.2	593.4	15%	85%
10	2	464.4	526.1	11%	74%
20	0.85	413.1	515.2	18%	56%
40	0.425	370	521.8	26%	30%
60	0.25	354	447.3	16%	14%
140	0.106	342	415.2	13%	2%
200	0.075	327.7	333.8	1%	1%
Pan		364	369.5	1%	

% Passing = 100 - % Retained

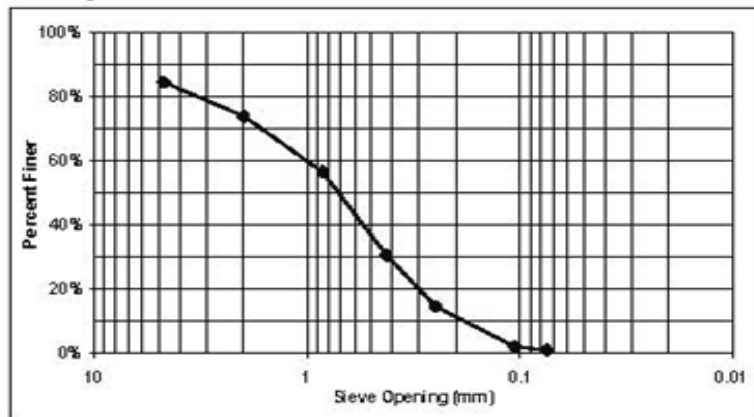

Detailed soils analysis



UNIVERSITY OF NEW MEXICO
DEPARTMENT OF CIVIL ENGINEERING

HYDROMETER ANALYSIS

The University of New Mexico

Project Urban Flood Demonstration Project		Requested By J. Pedro		Date 20-Mar-2007
Boring Identification ENS	Cylinder # 6	Depth (ft) 17 - 22	Time 11:43 AM	Sample #1 @ 50.0
Specific Gravity 2.70	Moisture Content (%) 24.0	Notes Soil Bag 6, Pan 3		

MENISCUS CORRECTION (m)	0
G _s CORRECTION FACTOR (α)	0.99
SUSPENSION CONSTANT (k)	0.01344
CORRECTED SAMPLE WGT. (W _s)	38.0
PERCENT PASSING #200 SIEVE	66%

Elapsed Time (min)	Hydrometer Reading		Temperature (°C)	Effective Depth (cm)		Particle Diameter (mm)	% Finer (%)
	Orig.	R _s		R _{s(Corr)}	Corrected		
2	26	26	21	12.0	11.8800	0.0328	44.7%
5	20	20	21	13.0	12.8700	0.0216	34.4%
10	16	16	21	13.7	13.5630	0.0157	27.5%
15	13	13	21	14.2	14.0680	0.0130	22.4%
20	12	12	20	14.3	14.1570	0.0113	20.6%
30	11	11	21	14.5	14.3550	0.0093	18.9%
60	8	8	20	15.0	14.8500	0.0067	13.8%
250	5	5	20	15.5	15.3450	0.0033	8.6%
1440	5	5	18	15.5	15.3450	0.0014	8.6%

Detailed soils analysis



UNIVERSITY OF NEW MEXICO
DEPARTMENT OF CIVIL ENGINEERING

HYDROMETER ANALYSIS

The University of New Mexico

Project Urban Flood Demonstration Project		Issued By J. Pedro		Date 27-Mar-2007
Soiling Identification ENS	Cylinder # 2	Depth (cm) 26-30	Time 1:10 PM	Sample Weight 50.0
Specific Gravity 2.70	Mixture Correction (C) 23.5	Notes Soil Bag 9, Pan 4		

MENISCUS CORRECTION (m)	<u>1</u>
G _s CORRECTION FACTOR (α)	<u>0.99</u>
SUSPENSION CONSTANT (k)	<u>0.01344</u>
CORRECTED SAMPLE WT. (W _s)	<u>38.3</u>
PERCENT PASSING #200 SIEVE	<u>55%</u>

Elapsed Time (min)	Hydrometer Reading		Temperature (°C)	Effective Depth (cm)		Particle Diameter (mm)	% Finer (%)
	Orig.	R _s		R _{a(Corr)}	Corrected		
2	45	44	20	9.1	9.0090	0.0285	62.6%
5	42	41	20	9.6	9.5040	0.0185	58.4%
10	36	35	19	10.6	10.4940	0.0138	49.8%
15	35	34	19	10.7	10.5930	0.0113	48.4%
20	32	31	19	11.2	11.0680	0.0100	44.1%
30	30	29	19	11.5	11.3850	0.0083	41.3%
60	26	25	20	12.2	12.0780	0.0060	35.6%
250	19	18	21	13.3	13.1670	0.0031	25.6%
1440	15	14	19	14.0	13.8600	0.0013	19.9%

Detailed soils analysis



UNIVERSITY OF NEWMEXICO
DEPARTMENT OF CIVIL ENGINEERING

HYDROMETER ANALYSIS

The University of New Mexico

Project Urban Flood Demonstration Project		Analyst By J. Pedro		Date 27-Mar-2007
Soil Identification ENS	Cylinder # 3	Depth (cm) 40.5 - 45.5	Time 1:14 PM	Sample Wt. (g) 50.0
Specific Gravity 2.70	Mixture Content (%) 12.1	Notes Soil Bag 13, Pan 5		

MENISCUS CORRECTION (m) 1
 G_s CORRECTION FACTOR (α) 0.99
 SUSPENSION CONSTANT (k) 0.01361
 CORRECTED SAMPLE WT. (W_s) 44.0
 PERCENT PASSING #200 SIEVE 43%

Elapsed Time (min)	Hydrometer Reading		Temperature (°C)	Effective Depth (cm)		Particle Diameter (mm)	% Finer (%)
	Orig.	R _s		R _{a(Corr)}	Corrected		
2	31	30	20	11.4	11.2860	0.0323	29.1%
5	25	24	20	12.4	12.2760	0.0213	23.2%
10	22	21	19	12.9	12.7710	0.0154	20.3%
15	20	19	19	13.2	13.0680	0.0127	18.4%
20	19	18	20	13.3	13.1670	0.0110	17.4%
30	17	16	20	13.7	13.5630	0.0092	15.5%
60	16	15	20	13.8	13.6620	0.0065	14.5%
250	14	13	19	14.2	14.0580	0.0032	12.6%
1440	13	12	18	14.3	14.1570	0.0013	11.6%

Detailed soils analysis



The University of New Mexico

UNIVERSITY OF NEW MEXICO
DEPARTMENT OF CIVIL ENGINEERING

GRAIN SIZE ANALYSIS

Urban Flood Demonstration Project
Project
I. Pedro
Tested By

ENS (Badger S)
Boring Identification
3 6
Pan No. Soil Bag

Sieve No.	Diameter (mm)	% Passing
4	4.75	100%
10	2	99%
20	0.85	93%
40	0.425	86%
60	0.25	79%
140	0.106	69%
200	0.075	66%
	0.0328	44.7%
	0.0216	34.4%
	0.0157	27.5%
	0.0130	22.4%
	0.0113	20.6%
	0.0093	18.9%
	0.0067	13.8%
	0.0033	8.6%
	0.0014	8.6%

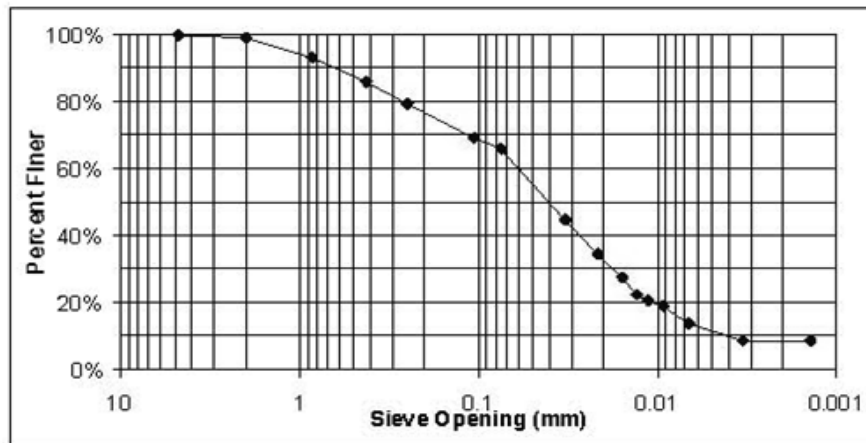

Detailed soils analysis



UNIVERSITY OF NEW MEXICO
DEPARTMENT OF CIVIL ENGINEERING

GRAIN SIZE ANALYSIS

Urban Flood Demonstration Project
Project
I. Pedro
Tested By

ENS (Badger S)
Boring Identification
4 9
Pan No. Soil Bag

Sieve No.	Diameter (mm)	% Passing
4	4.75	100%
10	2	97%
20	0.85	85%
40	0.425	74%
60	0.25	65%
140	0.106	56%
200	0.075	55%
	0.0285	62.6%
	0.0185	58.4%
	0.0138	49.8%
	0.0113	48.4%
	0.0100	44.1%
	0.0083	41.3%
	0.0060	35.6%
	0.0031	25.6%
	0.0013	19.9%

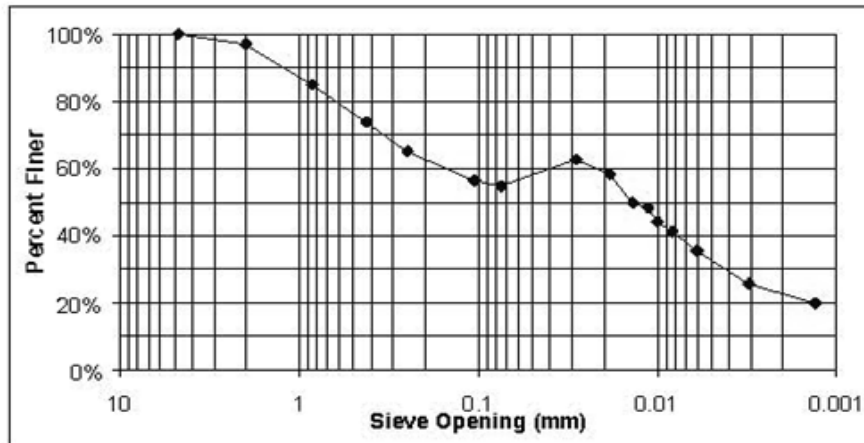

Detailed soils analysis



The University of New Mexico

UNIVERSITY OF NEW MEXICO
DEPARTMENT OF CIVIL ENGINEERING

GRAIN SIZE ANALYSIS

Urban Flood Demonstration Project
Project
I. Pedro
Tested By

ENS (Badger S)
Boring Identification
5 13
Pan No. Soil Bag

Sieve No.	Diameter (mm)	% Passing
4	4.75	100%
10	2	98%
20	0.85	83%
40	0.425	71%
60	0.25	64%
140	0.106	53%
200	0.075	43%
	0.0323	29.1%
	0.0213	23.2%
	0.0154	20.3%
	0.0127	18.4%
	0.0110	17.4%
	0.0092	15.5%
	0.0065	14.5%
	0.0032	12.6%
	0.0013	11.6%

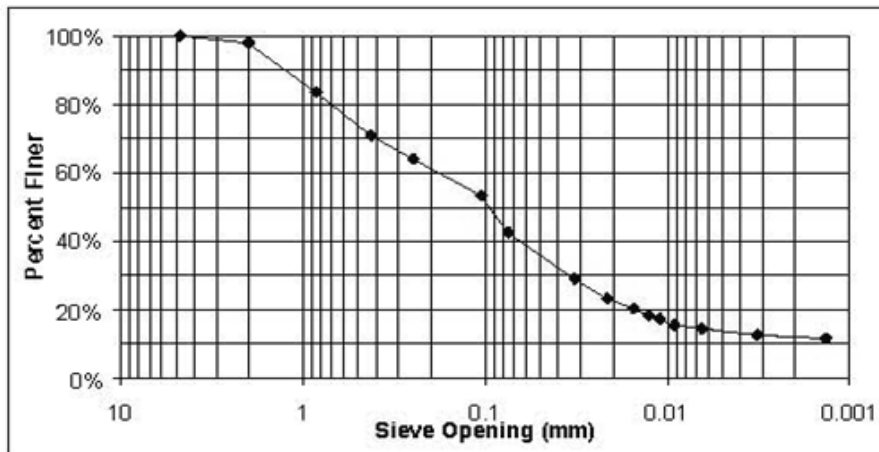

Detailed soils analysis



The University of New Mexico

UNIVERSITY OF NEW MEXICO
DEPARTMENT OF CIVIL ENGINEERING

SOIL BORING LOG INFORMATION

PAGE 1 of 2

Project Name Urban Flood Demonstration Project		Boring Classification ID ENC		Date of Drilling 14-Aug-06		Corresponding Well ID Badger (EU21) Center		
Boring Drilled By I. Pedro & C. LeJeune		Canopy Rain Gage N/A		Open Rain Gage N/A		Weather Cloudy		
Boring Location 3 Feet SW of Well		# of Soil Bags Collected 23		Master Table Depth 104"		Final Depth 106"		
				Well Bore Depth 109"		Timbers Use N/A		
SAMPLE		DESCRIPTION (Visual-Manual Method)						COMMENTS
DEPTH (ft)	NUMBER	MOISTURE	COLOR	DRY STRENGTH	DILATANCY	TOUGHNESS	PLASTICITY	
0	0	M	DBm					Organic material, twigs and leaves present
3	1	M	DBm	L	S	L	L	Sandy appearance with organic material present
7	2	M	Bm	L	S	L	L	Organic material present
13.5	3	M	Bm	L	S	L	L	
19	4	M	Bm	L	S	L	L	
24	5	M	Bm	L	S	L	L	
26	6	M	Bm	L	N	L	L	
28.5	7	M	DBm	M	N	M	L	Clayey appearance
34	8	M	DBm	H	N	M	M	Sample came out in clumps
37	9	M	DBm	M	S	M	M	Sample came out in clumps
38.5	10	M	Bm	L	S	L	L	More of a sandy appearance
44	11	M	Bm	M	S	L	L	
49	12	M	Bm	N	R	L	N	Bed sand appearance
52	13	M	Bm	L	S	M	M	
54.5	14	M	Tan	L	S	L	N	
60	15	M	Tan	L	R	L	N	
65	16	M	Tan	N	M	L	N	
70.5	17	M	Tan	N	R	L	N	
<p>I hereby certify that the information of this form is true and correct to the best of my knowledge</p>								
Signature				Print Name		Date		
				Isaiah Pedro / Chnstian Lejeune		14-Aug-06		

Detailed soils analysis



UNIVERSITY OF NEW MEXICO
DEPARTMENT OF CIVIL ENGINEERING

WATER CONTENT DETERMINATION

The University of New Mexico

Urban Flood Demonstration Project
Project

C. LeJeune and I. Pedro
Tested By

January 8, 2007
Date of Testing

January 9, 2007
Date of Dry Weighing

ENC (Badger C)
Boring Identification

CONTAINER NO. (CUP)	8	9	10	11*	12*	13	14*
FIELD TEXTURE	OM	B. Sand	B. Sand	Sand w/ Clay	Sand w/ Clay	B. Sand	B. Sand
BORING BAG NO.	1	2	5	7	9	11	13
DEPTH (in)	0 - 3	3 - 7	19 - 24	26 - 28.5	34 - 37	38.5 - 44	49 - 52
MASS OF CUP + WET SOIL (g)	252.6	549.8	639.9	405.5	596.7	609.4	456.6
MASS OF CUP + DRY SOIL (g)	233.4	484.1	596.4	359.1	532.7	577.0	426.3
MASS OF CUP (g)	138.0	139.4	139.4	137.6	137.2	138.6	138.3
MASS OF DRY SOIL, Ms (g)	95.4	344.7	457.0	221.5	395.5	438.4	288.0
MASS OF WATER, Mw (g)	19.2	65.7	43.5	46.4	64.0	32.4	30.3
WATER CONTENT, w (%)	20.1%	19.1%	9.5%	20.9%	16.2%	7.4%	10.5%

January 9, 2007
Date of Testing

January 10, 2007
Date of Dry Weighing

CONTAINER NO. (CUP)	1	2	3				
FIELD TEXTURE	L.B. Sand	L.B. Sand	L.B. Sand				
BORING BAG NO.	15	18	22				
DEPTH (in)	54.5 - 60	70.5 - 76	93 - 100				
MASS OF CUP + WET SOIL (g)	719.1	864.5	908.8				
MASS OF CUP + DRY SOIL (g)	697.5	827.1	871.0				
MASS OF CUP (g)	139.2	138.6	139.1				
MASS OF DRY SOIL, Ms (g)	558.3	688.5	731.9				
MASS OF WATER, Mw (g)	21.6	37.4	37.8				
WATER CONTENT, w (%)	3.9%	5.4%	5.2%				

$$w = \frac{M_w}{M_s} (100) \%$$

*Sample to be washed

Detailed soils analysis



The University of New Mexico

UNIVERSITY OF NEW MEXICO
DEPARTMENT OF CIVIL ENGINEERING

GRAIN SIZE ANALYSIS

Urban Flood Demonstration Program
Project

ENC (Badger C)
Boing Identification

I. Pedro & C. LeJeune
Tested By

8 Pan No. 1 Soil Bag No. 2 Sieve No.

January 9, 2007
Date of Testing

OM
Field Description of Soil

95.4
Mass of Dry Sample, M_s

0 - 3
Depth of Sample (m)

Sieve No.	Diameter (mm)	Mass of Sieve (g)	Mass retained (sieve + soil) (g)	% Retained	% Passing
4	4.75	515.7	515.7	0%	100%
10	2	490.7	492.6	2%	98%
20	0.85	412.6	420.1	8%	90%
40	0.425	381.9	392.5	11%	79%
60	0.25	366.8	376.9	11%	68%
140	0.106	342.5	363.4	22%	47%
200	0.075	338.7	351.1	13%	34%
Pan		364.0	394.9	34%	

% Passing = 100 - Σ% Retained

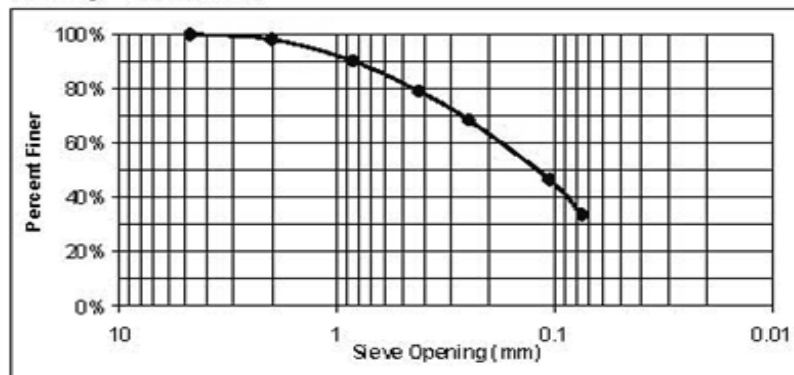

Detailed soils analysis



The University of New Mexico

UNIVERSITY OF NEW MEXICO
DEPARTMENT OF CIVIL ENGINEERING

GRAIN SIZE ANALYSIS

Urban Flood Demonstration Program

Project

ENC (Badger C)

Boing Identification

J. Pedro & C. LeJeune

Tested By

9

Pan No.

2

Soil Bag No.

1

Sieve No.

January 9, 2007

Date of Testing

Brown Sand

Field Description of Soil

344.7

Mass of Dry Sample, M_s

3 - 7

Depth of Sample (in)

Sieve No.	Diameter (mm)	Mass of Sieve (g)	Mass retained (sieve + soil) (g)	% Retained	% Passing
4	4.75	503.2	503.9	0%	100%
10	2	464.4	464.6	0%	100%
20	0.85	413.1	426.4	4%	96%
40	0.425	370.0	407.2	11%	85%
60	0.25	354.0	384.6	9%	76%
140	0.106	342.0	405.8	19%	58%
200	0.075	327.7	371.2	13%	45%
Pan		364.0	518.9	45%	

% Passing = 100 - Σ% Retained

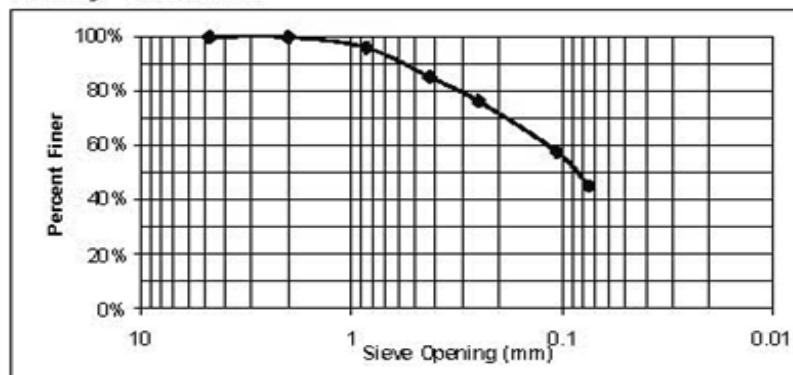

Detailed soils analysis



The University of New Mexico

UNIVERSITY OF NEW MEXICO
DEPARTMENT OF CIVIL ENGINEERING

GRAIN SIZE ANALYSIS

Urban Flood Demonstration Program
Project

ENC (Badger C)
Boiling Identification

I. Pedro & C. LeJeune
Tested By

10 Pan No. 5 Soil Bag No. 2 Sieve No.

January 9, 2007
Date of Testing

Brown Sand
Field Description of Soil

457.0
Mass of Dry Sample, M_s

19 - 24
Depth of Sample (n)

Sieve No.	Diameter (mm)	Mass of Sieve (g)	Mass retained (sieve + soil) (g)	% Retained	% Passing
4	4.75	515.7	515.7	0%	100%
10	2	490.7	490.6	0%	100%
20	0.85	412.6	418.7	1%	99%
40	0.425	381.9	396.0	3%	96%
60	0.25	366.8	379.6	3%	93%
140	0.106	342.5	408.2	14%	78%
200	0.075	338.7	423.7	19%	60%
Pan		364.0	635.9	60%	

% Passing = 100 - Σ% Retained

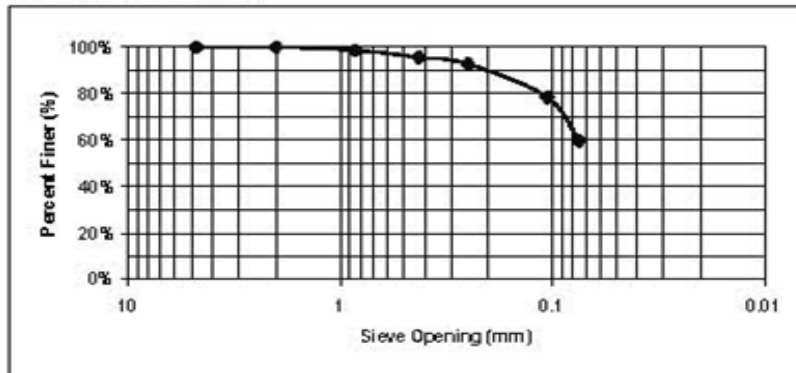

Detailed soils analysis



The University of New Mexico

UNIVERSITY OF NEW MEXICO
DEPARTMENT OF CIVIL ENGINEERING

GRAIN SIZE ANALYSIS

Urban Flood Demonstration Program
Projec

ENC (Badger C)
Boing Identification

I. Pedro & C. LeJeune
Tested By

11* 7 1
Pan No. Soil Bag No. Sieve No.

January 10, 2007
Date of Testing

Sand w/Clay
Field Description of Soil

221.5
Mass of Dry Sample, M_s

26 - 28.5
Depth of Sample (m)

Sieve No.	Diameter (mm)	Mass of Sieve (g)	Mass retained (sieve + soil) (g)	% Retained	% Passing
4	4.75	503.2	503.2	0%	100%
10	2	464.4	467.7	1%	99%
20	0.85	413.1	427.3	6%	92%
40	0.425	370.0	389.2	9%	83%
60	0.25	354.0	370.0	7%	76%
140	0.106	342.0	359.0	8%	69%
200	0.075	327.7	333.8	3%	66%
Pan		364.0	368.3	66%	
Washed			142.3		

*Material washed

% Passing = 100 - % Retained

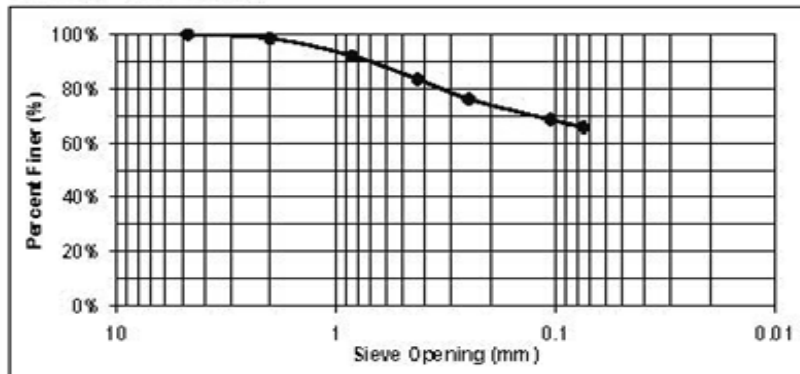

Detailed soils analysis



UNIVERSITY OF NEW MEXICO
DEPARTMENT OF CIVIL ENGINEERING

GRAIN SIZE ANALYSIS

The University of New Mexico

Urban Flood Demonstration Program
Project

ENC (Badger C)
Boiling Identification

I. Pedro & C. LeJeune
Tested By

12* 9 1
Pan No. Soil Bag No. Sieve No.

January 10, 2007
Date of Testing

Sand w/Clay
Field Description of Soil

395.5
Mass of Dry Sample, M_s

34 - 37
Depth of Sample (in)

Sieve No.	Diameter (mm)	Mass of Sieve (g)	Mass retained (sieve + soil) (g)	% Retained	% Passing
4	4.75	503.2	503.2	0%	100%
10	2	464.4	464.7	0%	100%
20	0.85	413.1	417.7	1%	99%
40	0.425	370.0	374.7	1%	98%
60	0.25	354.0	357.5	1%	97%
140	0.106	342.0	349.1	2%	95%
200	0.075	327.7	337.8	3%	92%
Pan		364.0	371.9	92%	
Washed			357		

% Passing = 100 - Σ% Retained

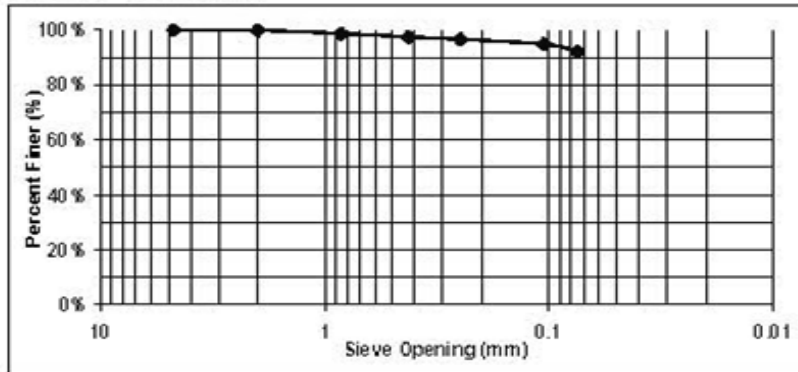

Detailed soils analysis



The University of New Mexico

UNIVERSITY OF NEW MEXICO
DEPARTMENT OF CIVIL ENGINEERING

GRAIN SIZE ANALYSIS

Urban Flood Demonstration Program
Projec

ENC (Badger C)
Boring Identification

I. Pedro & C. LeJeune
Tested By

13 Pan No. 11 Soil Bag No. 1 Sieve No.

January 9, 2007
Date of Testing

Brown Sand
Field Description of Soil

438.4
Mass of Dry Sample, M_s

38.5 - 44
Depth of Sample (m)

Sieve No.	Diameter (mm)	Mass of Sieve (g)	Mass retained (sieve + soil) (g)	% Retained	% Passing
4	4.75	503.2	503.2	0%	100%
10	2	464.4	465.3	0%	100%
20	0.85	413.1	434.5	5%	95%
40	0.425	370.0	391.4	5%	90%
60	0.25	354.0	370.2	4%	86%
140	0.106	342.0	396.1	12%	74%
200	0.075	327.7	416.5	20%	54%
Pan		364.0	597.5	54%	

% Passing = 100 - % Retained

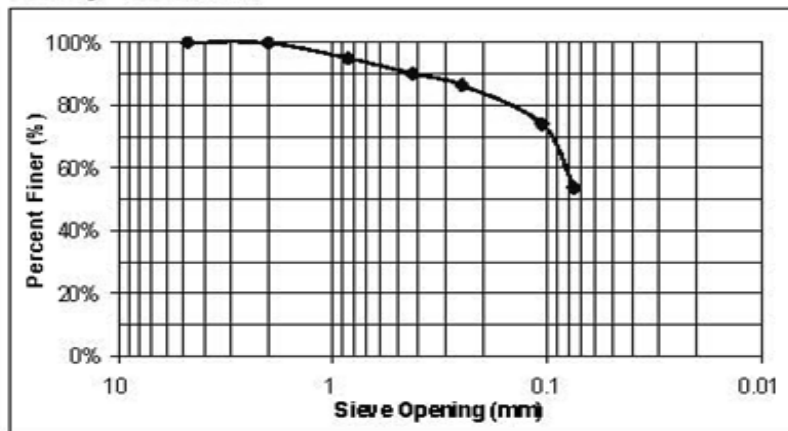

Detailed soils analysis



UNIVERSITY OF NEW MEXICO
DEPARTMENT OF CIVIL ENGINEERING

GRAIN SIZE ANALYSIS

The University of New Mexico

Urban Flood Demonstration Program
Projec

ENC (Badger C)
Boring Identification

I. Pedro & C. LeJeune
Tested By

14* 13 2
Pan No. Soil Bag No. Sieve No.

January 10, 2007
Date of Testing

Brown Sand
Field Description of Soil

288.0
Mass of Dry Sample, M_s

49 - 52
Depth of Sample (m)

Sieve No.	Diameter (mm)	Mass of Sieve (g)	Mass retained (sieve + soil) (g)	% Retained	% Passing
4	4.75	515.7	516.2	0%	100%
10	2	490.7	494.3	1%	99%
20	0.85	412.6	421.3	3%	96%
40	0.425	381.9	398.7	6%	90%
60	0.25	366.8	395.5	10%	80%
140	0.106	342.5	438.8	33%	46%
200	0.075	338.7	356.0	6%	40%
Pan		364.0	479.7	40%	
Washed			105.7		

% Passing = 100 - Σ% Retained

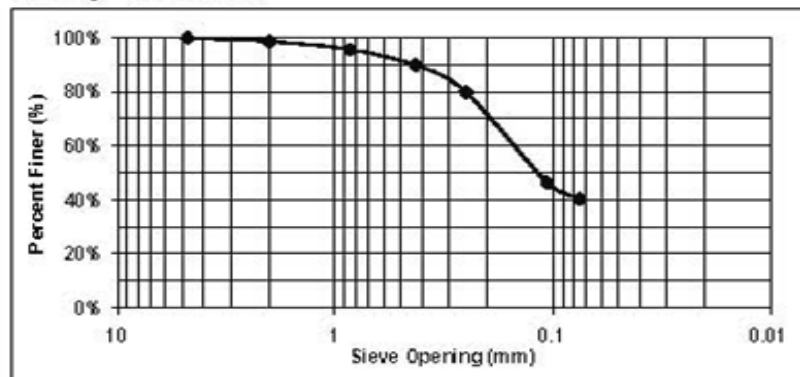

Detailed soils analysis



The University of New Mexico

UNIVERSITY OF NEW MEXICO
DEPARTMENT OF CIVIL ENGINEERING

GRAIN SIZE ANALYSIS

Urban Flood Demonstration Program

Projec

J. Pedro & C. LeJeune

Tested By

January 10, 2007

Date of Testing

558.3

Mass of Dry Sample, M_s

ENC (Badger C)

Boring Identification

1 15 1
Pan No. Soil Bag No. Sieve No.

Light Brown Sand

Field Description of Soil

54.5 - 60

Depth of Sample (n)

Sieve No.	Diameter (mm)	Mass of Sieve (g)	Mass retained (sieve + soil) (g)	% Retained	% Passing
4	4.75	503.2	504.0	0%	100%
10	2	464.4	475.7	2%	98%
20	0.85	413.1	427.9	3%	95%
40	0.425	370.0	389.9	4%	92%
60	0.25	354.0	407.5	10%	82%
140	0.106	342.0	709.9	66%	16%
200	0.075	327.7	385.3	10%	6%
Pan		364.0	395.5	6%	

% Passing = 100 - Σ% Retained

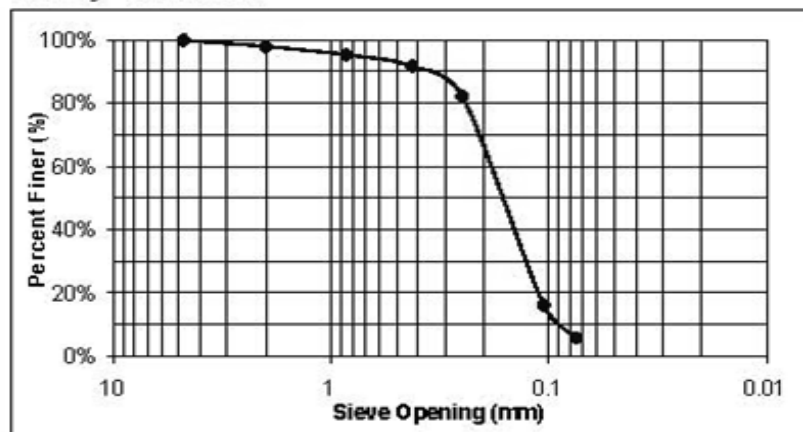

Detailed soils analysis



The University of New Mexico

UNIVERSITY OF NEW MEXICO
DEPARTMENT OF CIVIL ENGINEERING

GRAIN SIZE ANALYSIS

Urban Flood Demonstration Program
Projec

ENC (Badger C)
Boing Identification

J. Pedro & C. LeJeune
Tested By

2 18 2
Pan No. Soil Bag No. Sieve No.

January 10, 2007
Date of Testing

Light Brown Sand
Field Description of Soil

688.5
Mass of Dry Sample, M_s

70.5 - 76
Depth of Sample (in)

Sieve No.	Diameter (mm)	Mass of Sieve (g)	Mass retained (sieve + soil) (g)	% Retained	% Passing
4	4.75	515.7	517.0	0%	100%
10	2	490.7	498.4	1%	99%
20	0.85	412.6	434.5	3%	96%
40	0.425	381.9	455.3	11%	85%
60	0.25	366.8	559.0	28%	57%
140	0.106	342.5	699.4	52%	5%
200	0.075	338.7	361.7	3%	2%
Pan		364.0	374.9	2%	

% Passing = 100 - Σ% Retained

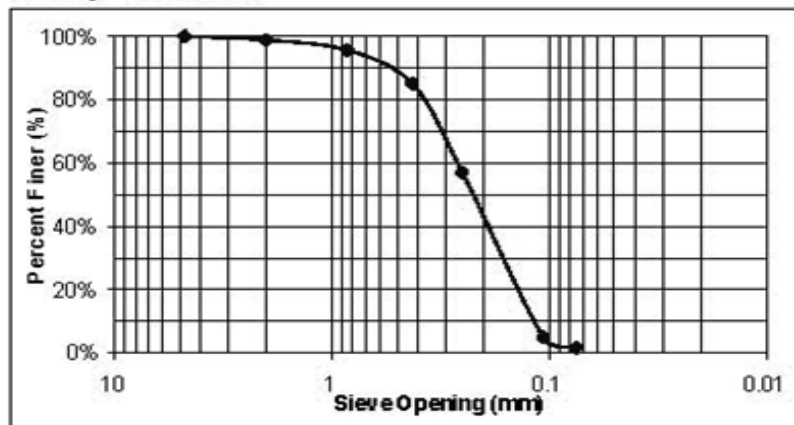

Detailed soils analysis



UNIVERSITY OF NEW MEXICO
DEPARTMENT OF CIVIL ENGINEERING

GRAIN SIZE ANALYSIS

The University of New Mexico

Urban Flood Demonstration Program
Project

ENC (Badger C)
Boiling Identification

I. Pedro & C. LeJeune
Tested By

3 Pan No. 22 Soil Bag No. 1 Sieve No.

January 10, 2007
Date of Testing

Light Brown Sand
Field Description of Soil

731.9
Mass of Dry Sample, M_s

93 - 100
Depth of Sample (in)

Sieve No.	Diameter (mm)	Mass of Sieve (g)	Mass retained (sieve + soil) (g)	% Retained	% Passing
4	4.75	503.2	506.0	0%	100%
10	2	464.4	475.4	2%	98%
20	0.85	413.1	479.2	9%	89%
40	0.425	370.0	669.6	41%	48%
60	0.25	354.0	570.1	30%	19%
140	0.106	342.0	454.5	15%	3%
200	0.075	327.7	340.9	2%	1%
Pan		364.0	373.9	1%	

% Passing = 100 - Σ% Retained

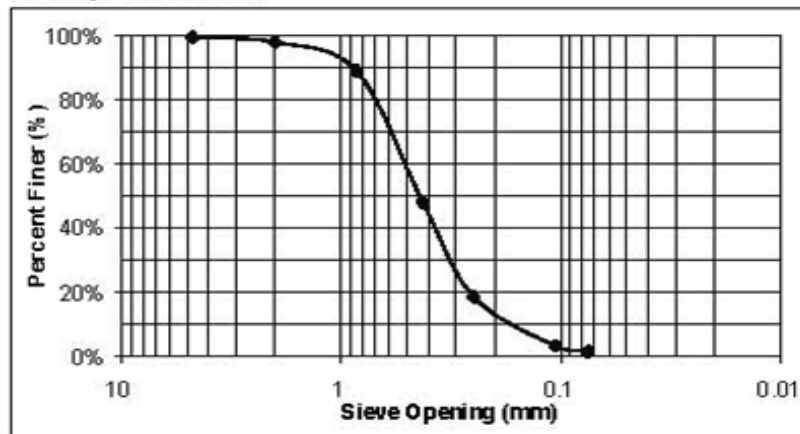

Detailed soils analysis



The University of New Mexico

UNIVERSITY OF NEWMEXICO
DEPARTMENT OF CIVIL ENGINEERING

HYDROMETER ANALYSIS

Project Urban Flood Demonstration Project		Issued By J. Pedro		Date 14 Mar 2007
Soing Identification ENC	Cylinder # 2	Exp # (ID) 3 - 7	Time 11:05 AM	Sample Wt. (g) 50.0
Specific Gravity 2.70	Mixture Content (%) 19.1	Notes Pan 9, Soil Bag 2		

MENISCUS CORRECTION (m)	<u>6</u>
G _s CORRECTION FACTOR (α)	<u>0.99</u>
SUSPENSION CONSTANT (k)	<u>0.01361</u>
CORRECTED SAMPLE WT. (W _s)	<u>40.5</u>
PERCENT PASSING #200 SIEVE	<u>45%</u>

Elapsed Time (min)	Hydrometer Reading		Temperature (°C)	Effective Depth (cm)		Particle Diameter (mm)	% Finer (%)
	Orig.	R _s		R _{s(Com)}	Corrected		
2	27	21	19	12.9	12.7710	0.0344	23.1%
5	16	10	19	14.7	14.5530	0.0232	11.0%
10	12	6	19	15.3	15.1470	0.0168	6.6%
15	10	4	18	15.6	15.4440	0.0138	4.4%
20	10	4	18	15.6	15.4440	0.0120	4.4%
30	8	2	19	16.0	15.8400	0.0099	2.2%
60	7	1	19	16.1	15.9390	0.0070	1.1%
250	6	0	19	16.3	16.1370	0.0035	0.0%
1440	6	0	19	16.3	16.1370	0.0014	0.0%

Detailed soils analysis



UNIVERSITY OF NEW MEXICO
DEPARTMENT OF CIVIL ENGINEERING

HYDROMETER ANALYSIS

The University of New Mexico

Project Urban Flood Demonstration Project		Prepared By I. Pedra		Date 14 Mar 2007
Boring Identification ENC	Cylinder # 3	Depth (m) 19 - 24	Time 11:13 AM	Sample Wt. (g) 50.0
Specific Gravity 2.70	Moisture Content (%) 9.5	Notes Pan 10, Soil Bag 5		

MENISCUS CORRECTION (m)	<u>6</u>
G _s CORRECTION FACTOR (α)	<u>0.99</u>
SUSPENSION CONSTANT (k)	<u>0.01378</u>
CORRECTED SAMPLE WT. (V _s)	<u>45.3</u>
PERCENT PASSING #200 SIEVE	<u>60%</u>

Elapsed Time (min)	Hydrometer Reading		Temperature (°C)	Effective Depth (cm)		Particle Diameter (mm)	% Finer (%)
	Orig.	R _s		R _{a(Corr)}	Corrected		
2	16	10	18	14.7	14.5530	0.0372	13.1%
5	14	8	18	15.0	14.8500	0.0237	10.5%
10	12	6	18	15.3	15.1470	0.0170	7.9%
15	9	3	18	15.8	15.6420	0.0141	3.9%
20	8	2	18	16.0	15.8400	0.0123	2.6%
30	8	2	19	16.0	15.8400	0.0100	2.6%
60	7	1	18	16.1	15.9390	0.0071	1.3%
250	6	0	18	16.3	16.1370	0.0035	0.0%
1440	6	0	18	16.3	16.1370	0.0015	0.0%

Detailed soils analysis



UNIVERSITY OF NEW MEXICO
DEPARTMENT OF CIVIL ENGINEERING

HYDROMETER ANALYSIS

The University of New Mexico

Project Urban Flood Demonstration Project			Prepared By I. Pedro		Date 14 Mar-2007
Boring Identification ENC	Cylinder # 4	Depth (ft) 34 - 37	Time 11:20 AM		Sample Wt. (g) 50.0
Specific Gravity 2.70	Moisture Content (%) 16.2		Notes Soil Bag 9, Pan 12		

MENISCUS CORRECTION (m)	<u>6</u>
G _s CORRECTION FACTOR (α)	<u>0.99</u>
SUSPENSION CONSTANT (k)	<u>0.01378</u>
CORRECTED SAMPLE WT. (W _s)	<u>41.9</u>
PERCENT PASSING #200 SIEVE	<u>92%</u>

Elapsed Time (min)	Hydrometer Reading		Temperature (°C)	Effective Depth (cm)		Particle Diameter (mm)	% Finer (%)
	Orig.	R _s		R _{s(Corr)}	Corrected		
2	27	21	18	12.9	12.7710	0.0348	45.6%
5	15	9	18	14.8	14.6520	0.0236	19.6%
10	15	9	18	14.8	14.6520	0.0167	19.6%
15	15	9	19	14.8	14.6520	0.0136	19.6%
20	14	8	19	15.0	14.8500	0.0119	17.4%
30	13	7	18	15.2	15.0480	0.0098	15.2%
60	12	6	19	15.3	15.1470	0.0069	13.0%
250	11	5	18	15.5	15.3450	0.0034	10.9%
1440	9	3	18	15.8	15.6420	0.0014	6.5%

Detailed soils analysis



UNIVERSITY OF NEWMEXICO
DEPARTMENT OF CIVIL ENGINEERING

HYDROMETER ANALYSIS

The University of New Mexico

Project Urban Flood Demonstration Project		Designed By J. Pedro		Date 14-Mar-2007
Soiling Classification ENC	Cylinder # 5	Depth (cm) 49-52	Time 11:26 AM	Sample #1 (g) 50.0
Specific Gravity 2.70	Mohr's Correction (%) 10.5	Notes Soil Bag 13, Pan 14		

MENISCUS CORRECTION (m)	<u>6</u>
G _s CORRECTION FACTOR (α)	<u>0.99</u>
SUSPENSION CONSTANT (K)	<u>0.01378</u>
CORRECTED SAMPLE WT. (W _s)	<u>44.8</u>
PERCENT PASSING #200 SIEVE	<u>40%</u>

Elapsed Time (min)	Hydrometer Reading		Temperature (°C)	Effective Depth (cm)		Particle Diameter (mm)	% Finer (%)
	Orig.	R _s		R _{s(Comp)}	Corrected		
2	32	26	18	12.0	11.8800	0.0336	23.0%
5	29	23	18	12.5	12.3750	0.0217	20.4%
10	27	21	19	12.9	12.7710	0.0156	18.6%
15	24	18	19	13.3	13.1670	0.0129	15.9%
20	22	16	19	13.7	13.5630	0.0113	14.2%
30	20	14	19	14.0	13.8600	0.0094	12.4%
60	18	12	18	14.3	14.1570	0.0067	10.6%
250	15	9	18	14.8	14.6520	0.0033	8.0%
1440	12	6	18	15.3	15.1470	0.0014	5.3%

Detailed soils analysis



UNIVERSITY OF NEW MEXICO
DEPARTMENT OF CIVIL ENGINEERING

GRAIN SIZE ANALYSIS

The University of New Mexico

Urban Flood Demonstration Project
Project
I. Pedro
Tested By

ENC (Badger C)
Boring Identification
9 2
Pan No. Soil Bag

Sieve No.	Diameter (mm)	% Passing
4	4.75	100%
10	2	100%
20	0.85	96%
40	0.425	85%
60	0.25	76%
140	0.106	58%
200	0.075	45%
	0.0344	23.1%
	0.0232	11.0%
	0.0168	6.6%
	0.0138	4.4%
	0.0120	4.4%
	0.0099	2.2%
	0.0070	1.1%
	0.0035	0.0%
	0.0014	0.0%

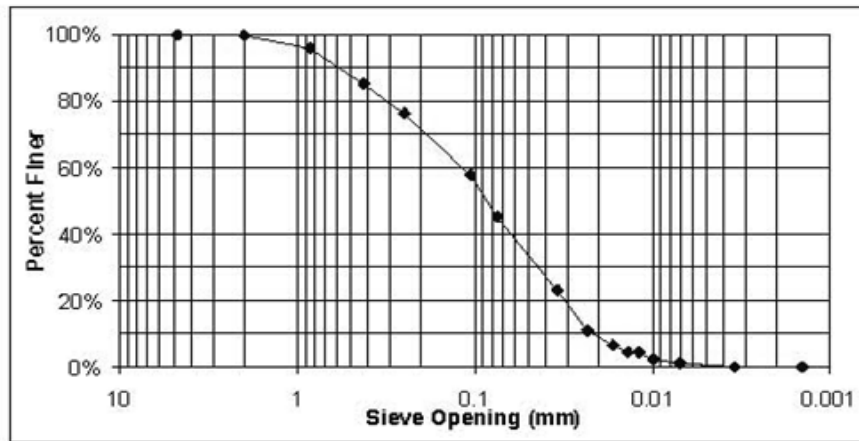

Detailed soils analysis



UNIVERSITY OF NEW MEXICO
DEPARTMENT OF CIVIL ENGINEERING

GRAIN SIZE ANALYSIS

The University of New Mexico

Urban Flood Demonstration Project
Project
I. Pedro
Tested By

ENC (Badger C)
Boring Identification
10 5
Pan No. Soil Bag

Sieve No.	Diameter (mm)	% Passing
4	4.75	100%
10	2	100%
20	0.85	99%
40	0.425	96%
60	0.25	93%
140	0.106	78%
200	0.075	60%
	0.0372	13.1%
	0.0237	10.5%
	0.0170	7.9%
	0.0141	3.9%
	0.0123	2.6%
	0.0100	2.6%
	0.0071	1.3%
	0.0035	0.0%
	0.0015	0.0%

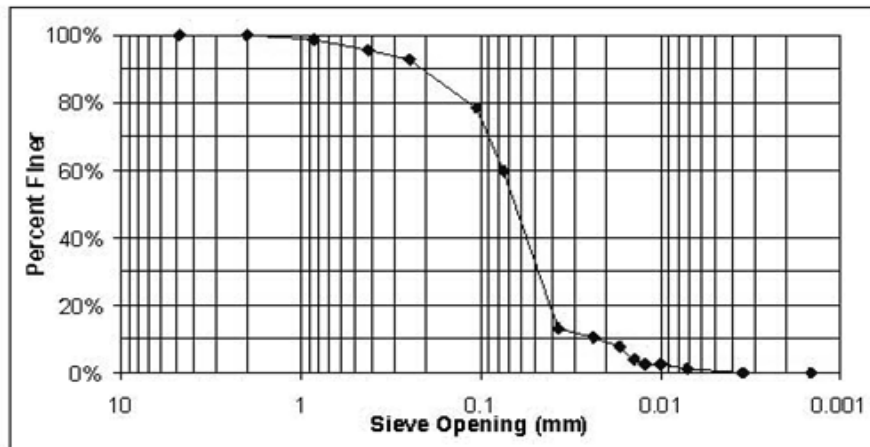

Detailed soils analysis



The University of New Mexico

UNIVERSITY OF NEW MEXICO
DEPARTMENT OF CIVIL ENGINEERING

GRAIN SIZE ANALYSIS

Urban Flood Demonstration Project
Project
I. Pedro
Tested By

ENC (Badger C)
Boring Identification
12 9
Pan No. Soil Bag

Sieve No.	Diameter (mm)	% Passing
4	4.75	100%
10	2	100%
20	0.85	99%
40	0.425	98%
60	0.25	97%
140	0.106	95%
200	0.075	92%
	0.0348	45.6%
	0.0236	19.6%
	0.0167	19.6%
	0.0136	19.6%
	0.0119	17.4%
	0.0098	15.2%
	0.0069	13.0%
	0.0034	10.9%
	0.0014	6.5%

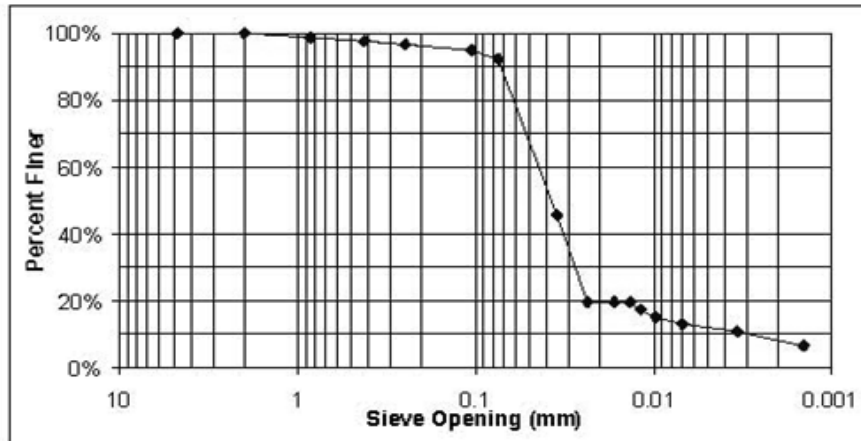

Detailed soils analysis



UNIVERSITY OF NEW MEXICO
DEPARTMENT OF CIVIL ENGINEERING

GRAIN SIZE ANALYSIS

The University of New Mexico

Urban Flood Demonstration Project
Project
I. Pedro
Tested By

ENC (Badger C)
Boring Identification
14 13
Pan No. Soil Bag

Sieve No.	Diameter (mm)	% Passing
4	4.75	100%
10	2	99%
20	0.85	96%
40	0.425	90%
60	0.25	80%
140	0.106	46%
200	0.075	40%
	0.0336	23.0%
	0.0217	20.4%
	0.0156	18.6%
	0.0129	15.9%
	0.0113	14.2%
	0.0094	12.4%
	0.0067	10.6%
	0.0033	8.0%
	0.0014	5.3%

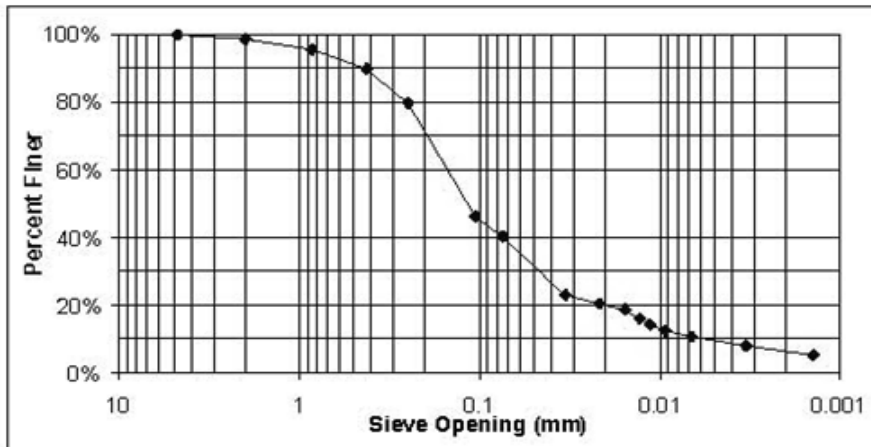

Detailed soils analysis



UNIVERSITY OF NEW MEXICO
DEPARTMENT OF CIVIL ENGINEERING

SOIL BORING LOG INFORMATION

PAGE 1 of 2

The University of New Mexico

Project Name Urban Flood Demonstration Project		Boring Classification ID ENE		Date of Drilling 16-Aug-06		Corresponding Well ID Badger (EU21) East		
Boring Drilled By J. Pedro & C. LeJeune		Canopy Rain Gage N/A		Open Rain Gage N/A		Weather Sunny		
Boring Location 3 Feet SE of Well		# of Soil Bags Collected 24		Water Table Depth 118.5"		Final Depth 120"		
				Well Casing Depth 117"		Temperature 86 F		
SAMPLE		DESCRIPTION (Visual-Manual Method)						COMMENTS
DEPTH (ft)	NUMBER	MOISTURE	COLOR	DRY STRENGTH	DILATANCY	TOUGHNESS	PLASTICITY	
0	0	M	DBm					Organic material, twigs and leaves present
7.5	1	M	DBm	M	S	M	M	Organic material present with a sandy appearance. Material did have some clay properties
13.5	2	M	DBm	L	S	L	L	Sandy appearance with some gravel present
19.5	3	M	Bm	M	S	M	M	Sandy appearance
22	4	M	Bm	M	S	M	M	↓
24	5	M	LBm	M	S	M	M	
29	6	M	RBm	M	S	M	H	Sample came out in clumps with a sandy clay appearance
33.5	7	M	Bm	M	N	L	L	↓
37.5	8	M	Bm	M	N	L	L	
43	9	M	Bm	L	N	L	L	↓
45	10	M	Bm	L	S	M	M	
49.5	11	M	LBm	L	R	L	N	More sandy appearance
56	12	M	LBm	N	R	L	N	↓
60.5	13	M	LBm	N	R	L	N	
66	14	M	LBm	N	R	L	N	↓
71	15	M	LBm	N	R	L	N	
78.5	16	M	LBm	N	R	L	N	↓
83.5	17	M	LBm	N	R	L	N	
<p>I hereby certify that the information of this form is true and correct to the best of my knowledge</p>								
Signature				Print Name		Date		
				Isaiah Pedro / Christian LeJeune		16-Aug-06		

Detailed soils analysis



UNIVERSITY OF NEW MEXICO
DEPARTMENT OF CIVIL ENGINEERING

WATER CONTENT DETERMINATION

The University of New Mexico

Urban Flood Demonstration Project
Project

I. Pedro
Tested By

December 5, 2006
Date of Testing

December 6, 2006
Date of Dry Weighing

ENE (Badger E)
Boring Identification

CONTAINER NO. (CUP)	1*	2*	3*	4*	5*	6*	7
FIELD TEXTURE	OM	Sand w/Clay	B. Sand w/Clay	B. Sand w/Clay	B. Sand w/Clay	B. Sand w/Clay	L.B. Sand
BORING BAG NO.	1	2	3	6	9	11	14
DEPTH (in)	0 - 7.5	7.5 - 13.5	13.5 - 19.5	24 - 29	37.5 - 43	45 - 49.5	60.5 - 66
MASS OF CUP+WET SOIL (g)	649.6	718.9	778.0	660.4	691.4	554.5	598.3
MASS OF CUP+DRY SOIL (g)	570.0	646.0	676.8	568.7	625.8	543.5	592.6
MASS OF CUP (g)	139.2	138.6	139.1	139.2	138.9	139.0	137.8
MASS OF DRY SOIL, Ms (g)	430.8	507.4	537.7	429.5	486.9	404.5	454.8
MASS OF WATER, Mw (g)	79.6	72.9	101.2	91.7	66.6	11.0	5.7
WATER CONTENT, w (%)	18.5%	14.4%	18.8%	21.4%	13.5%	2.7%	1.3%

CONTAINER NO. (CUP)	8	9	10	11			
FIELD TEXTURE	L.B. Sand	Sand w/Gravel	Sand w/Gravel	L.B. Sand			
BORING BAG NO.	16	17	20	24			
DEPTH (in)	66 - 78.5	78.5 - 83.5	95 - 100	116.5 - 120			
MASS OF CUP+WET SOIL (g)	810.5	742.4	941.0	781.7			
MASS OF CUP+DRY SOIL (g)	803.2	733.6	926.0	676.2			
MASS OF CUP (g)	138.0	139.4	139.4	137.6			
MASS OF DRY SOIL, Ms (g)	665.2	594.2	786.6	538.6			
MASS OF WATER, Mw (g)	7.3	8.8	15.0	105.5			
WATER CONTENT, w (%)	1.1%	1.5%	1.9%	19.6%			

$$w = \frac{M_w}{M_s} (100) \%$$

*Sample to be washed

Detailed soils analysis



UNIVERSITY OF NEW MEXICO
DEPARTMENT OF CIVIL ENGINEERING

GRAIN SIZE ANALYSIS

Urban Flood Demonstration Project
Project

ENE (Badger E)
Boring Identification

L. Pedro
Tested By

1* 1 2
Pan No. Soil Bag No. Sieve Set

December 6, 2006
Date of Testing

OM
Field Description of Soil

322.2
Mass of Dry Sample (g), M

0 - 7.5
Depth of Sample (m)

*Non-Washed Material

Sieve No.	Diameter (mm)	Mass of Sieve (g)	Mass retained (sieve + soil) (g)	% Retained	% Passing
4	4.75	515.7	515.7	0%	100%
10	2	490.7	494	1%	99%
20	0.85	412.6	452.5	12%	87%
40	0.425	381.9	446	20%	67%
60	0.25	366.8	410.2	13%	53%
140	0.106	342.5	407.4	20%	33%
200	0.075	338.7	368.3	9%	24%
Pan		364	440.5	24%	

% Passing = 100 - % Retained

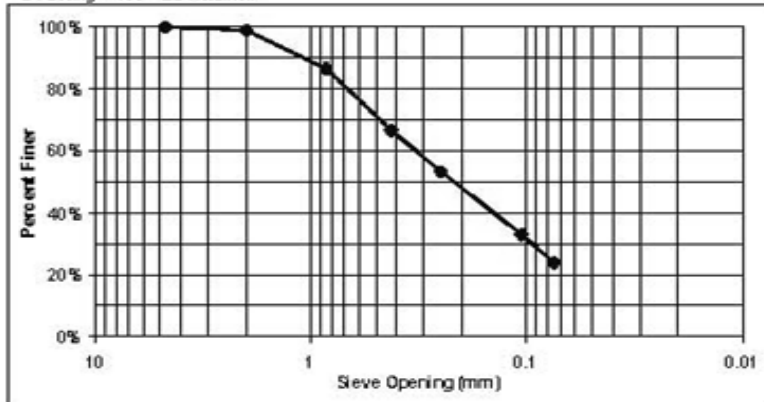

Detailed soils analysis



The University of New Mexico

UNIVERSITY OF NEW MEXICO
DEPARTMENT OF CIVIL ENGINEERING

GRAIN SIZE ANALYSIS

Urban Flood Demonstration Project
Projec

ENE (Badger E)
Boring Identification

I. Pedro & C. LaJeune
Tested By

1** 1 1
Pan No. Soil Bag No. Sieve Set

December 8, 2006
Date of Testing

OM
Field Description of Soil

108.6
Mass of Dry Sample (g), M

0 - 7.5
Depth of Sample (in)

**Washed Material

Sieve No.	Diameter (mm)	Mass of Sieve (g)	Mass retained (sieve + soil) (g)	% Retained	% Passing
4	4.75	503.2	503.2	0%	100%
10	2	464.4	464.4	0%	100%
20	0.85	413.1	415.7	2%	98%
40	0.425	370	375.9	5%	92%
60	0.25	354	361.6	7%	85%
140	0.106	342	359.6	16%	69%
200	0.075	327.7	337.6	9%	60%
Pan		364	428.9	60%	

% Passing = 100 - % Retained

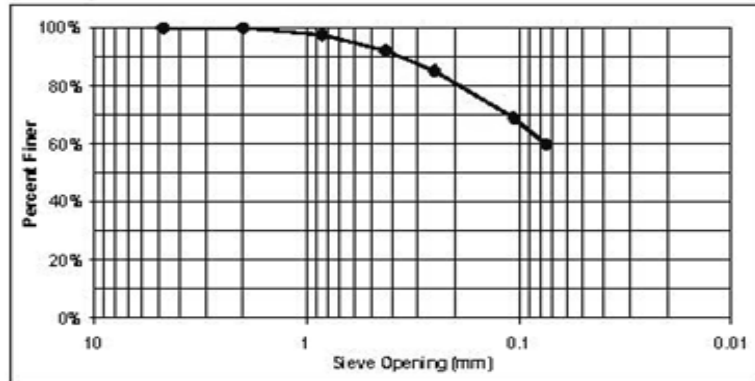

Detailed soils analysis



UNIVERSITY OF NEW MEXICO
DEPARTMENT OF CIVIL ENGINEERING

GRAIN SIZE ANALYSIS

Urban Flood Demonstration Project
Projec

ENE (Badger E)
Boring Identification

I. Pedro
Tested By

2 2 1
Pan No. Soil Bag No. Sieve Set

December 6, 2006
Date of Testing

Sand w/Clay
Field Description of Soil

348.8
Mass of Dry Sample (g), M_s

7.5 - 13.5
Depth of Sample (m)

*Non-Washed Material

Sieve No.	Diameter (mm)	Mass of Sieve (g)	Mass retained (sieve + soil) (g)	% Retained	% Passing
4	4.75	503.2	503.2	0%	100%
10	2	464.4	466.8	1%	99%
20	0.85	413.1	442.1	8%	91%
40	0.425	370	420.2	14%	77%
60	0.25	354	394.4	12%	65%
140	0.106	342	408.8	19%	46%
200	0.075	327.7	372.7	13%	33%
Pan		364	480.4	33%	

% Passing = 100 - % Retained

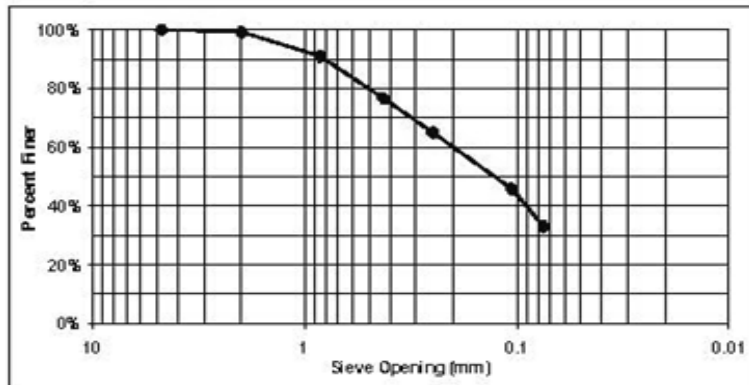

Detailed soils analysis



UNIVERSITY OF NEW MEXICO
DEPARTMENT OF CIVIL ENGINEERING

GRAIN SIZE ANALYSIS

Urban Flood Demonstration Project
Project

ENE (Badger E)
Boring Identification

I. Pedro & C. LeJeune
Tested By

2** 2 2
Pan No. Soil Bag No. Sieve Set

December 8, 2006
Date of Testing

Sand w/Clay
Field Description of Soil

158.6
Mass of Dry Sample (g), M

7.5 - 13.5
Depth of Sample (ft)

**Washed Material

Sieve No.	Diameter (mm)	Mass of Sieve (g)	Mass retained (sieve + soil) (g)	% Retained	% Passing
4	4.75	515.7	517.1	1%	99%
10	2	490.7	493.1	2%	98%
20	0.85	412.6	413.9	1%	97%
40	0.425	381.9	386	3%	94%
60	0.25	366.8	373.6	4%	90%
140	0.106	342.5	359.7	11%	79%
200	0.075	338.7	351.2	8%	71%
Pan		364	476.1	71%	

% Passing = 100 - % Retained

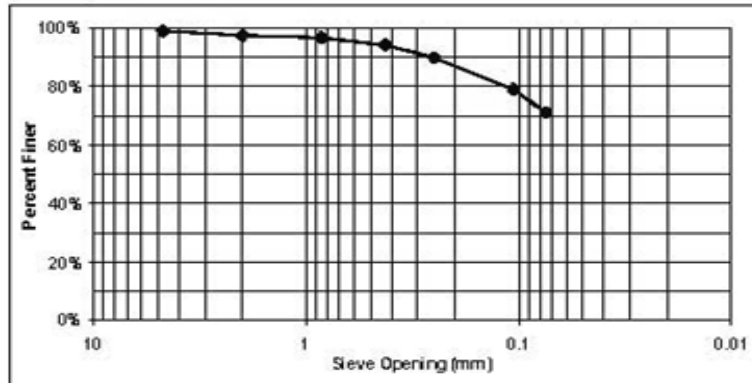

Detailed soils analysis



UNIVERSITY OF NEW MEXICO
DEPARTMENT OF CIVIL ENGINEERING

GRAIN SIZE ANALYSIS

Urban Flood Demonstration Project
Project

ENE (Badger E)
Boring Identification

I. Pedro
Tested By

3rd Pan No. 3 Soil Bag No. 2 Sieve Set

December 6, 2006
Date of Testing

Brown Sand w/Clay
Field Description of Soil

364.2
Mass of Dry Sample (g), M

13.5 - 19.5
Depth of Sample (ft)

*Non-Washed Material

Sieve No.	Diameter (mm)	Mass of Sieve (g)	Mass retained (sieve + soil) (g)	% Retained	% Passing
4	4.75	515.7	515.7	0%	100%
10	2	490.7	491	0%	100%
20	0.85	412.6	425.4	4%	96%
40	0.425	381.9	409.8	8%	89%
60	0.25	366.8	392.4	7%	82%
140	0.106	342.5	385.9	12%	70%
200	0.075	338.7	375.4	10%	60%
Pan		364	580.8	60%	

% Passing = 100 - % Retained

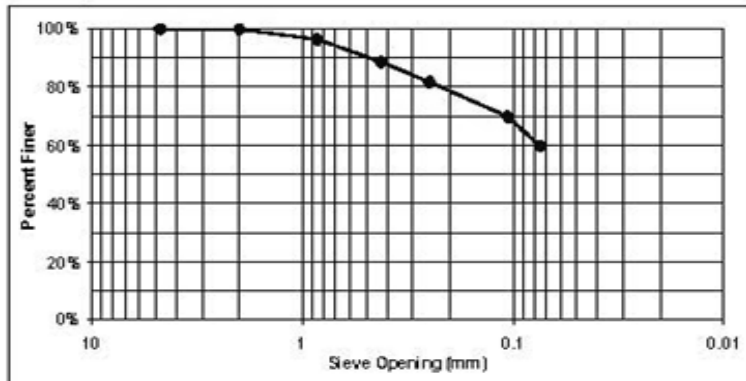

Detailed soils analysis



The University of New Mexico

UNIVERSITY OF NEW MEXICO
DEPARTMENT OF CIVIL ENGINEERING

GRAIN SIZE ANALYSIS

Urban Flood Demonstration Project
Projec

ENE (Badger E)
Boring Identification

I. Pedro & C. LeJeune
Tested By

3** 3 1
Pan No. Soil Bag No. Sieve Set

December 8, 2006
Date of Testing

Brown Sand w/Clay
Field Description of Soil

173.5
Mass of Dry Sample (g), M

13.5 - 19.5
Depth of Sample (m)

**Washed Material

Sieve No.	Diameter (mm)	Mass of Sieve (g)	Mass retained (sieve + soil) (g)	% Retained	% Passing
4	4.75	503.2	503.2	0%	100%
10	2	464.4	464.8	0%	100%
20	0.85	413.1	414.1	1%	99%
40	0.425	370	371.8	1%	98%
60	0.25	354	355.8	1%	97%
140	0.106	342	348.6	4%	93%
200	0.075	327.7	337.5	6%	88%
Pan		364	515.4	88%	

% Passing = 100 - % Retained

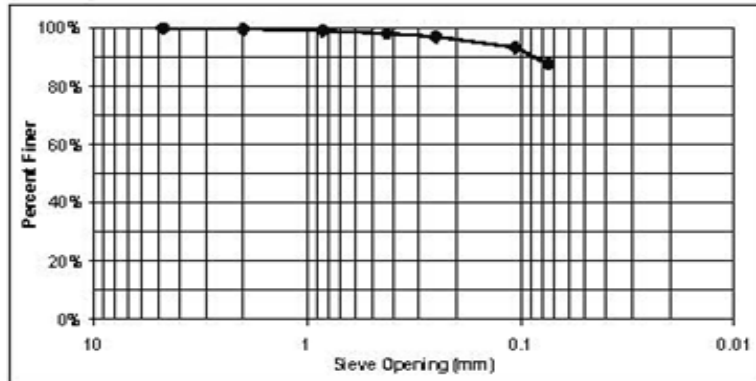

Detailed soils analysis



UNIVERSITY OF NEW MEXICO
DEPARTMENT OF CIVIL ENGINEERING

GRAIN SIZE ANALYSIS

Urban Flood Demonstration Project
Project

ENE (Badger E)
Boring Identification

L. Pedro
Tested By

4 Pan No. 6 Soil Bag No. 1 Sieve Set

December 6, 2006
Date of Testing

Brown Sand w/Clay
Field Description of Soil

244.2
Mass of Dry Sample (g), M

24 - 29
Depth of Sample (m)

*Non-Washed Material

Sieve No.	Diameter (mm)	Mass of Sieve (g)	Mass retained (sieve + soil) (g)	% Retained	% Passing
4	4.75	503.2	503.2	0%	100%
10	2	464.4	464.5	0%	100%
20	0.85	413.1	487.5	30%	69%
40	0.425	370	430.9	25%	45%
60	0.25	354	381.3	11%	33%
140	0.106	342	368.6	11%	22%
200	0.075	327.7	337.7	4%	18%
Pan		364	409.4	18%	

% Passing = 100 - % Retained

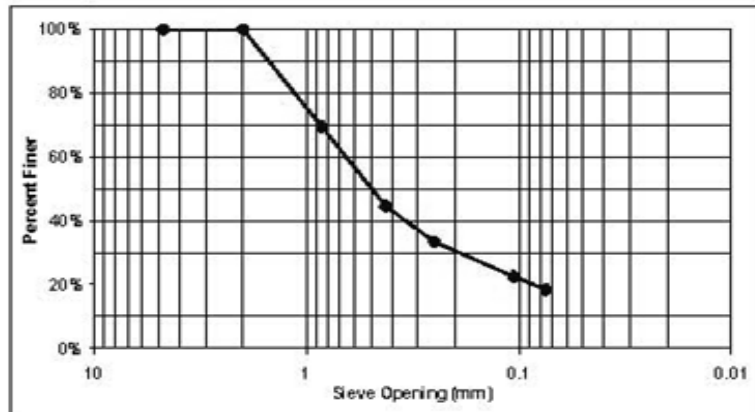

Detailed soils analysis



The University of New Mexico

UNIVERSITY OF NEW MEXICO
DEPARTMENT OF CIVIL ENGINEERING

GRAIN SIZE ANALYSIS

Urban Flood Demonstration Project
Project

ENE (Badger E)
Boring Identification

L. Pedro
Tested By

4** Pan No. 6 Soil Bag No. 2 Sieve Set

December 8, 2006
Date of Testing

Brown Sand w/Clay
Field Description of Soil

185.3
Mass of Dry Sample (g), M_s

24 - 29
Depth of Sample (m)

**Washed Material

Sieve No.	Diameter (mm)	Mass of Sieve (g)	Mass retained (sieve + soil) (g)	% Retained	% Passing
4	4.75	515.7	515.7	0%	100%
10	2	490.7	497.2	4%	96%
20	0.85	412.6	426.2	7%	89%
40	0.425	381.9	395.8	8%	82%
60	0.25	366.8	376.4	5%	76%
140	0.106	342.5	349.4	4%	73%
200	0.075	338.7	340	1%	72%
Pan		364	497.5	72%	

% Passing = 100 - Σ% Retained

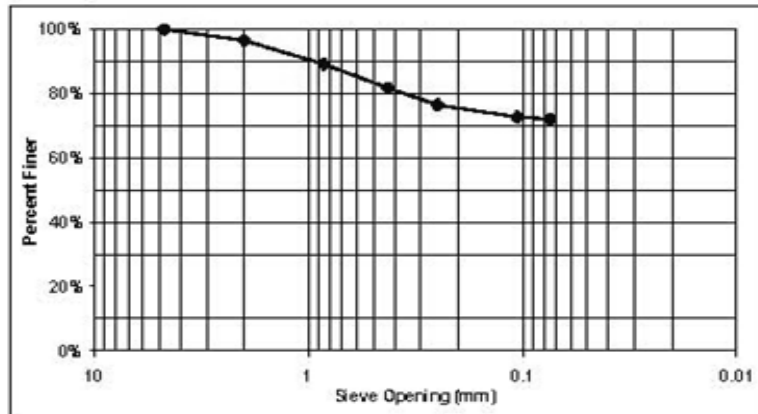

Detailed soils analysis



UNIVERSITY OF NEW MEXICO
DEPARTMENT OF CIVIL ENGINEERING

GRAIN SIZE ANALYSIS

Urban Flood Demonstration Project
Project

ENE (Badger E)
Boring Identification

I. Pedro
Tested By

5th 9 2
Pan No. Soil Bag No. Sieve Set

December 6, 2006
Date of Testing

Brown Sand w/Clay
Field Description of Soil

301.5
Mass of Dry Sample (g), M

37.5 - 43
Depth of Sample (ft)

*Non-Washed Material

Sieve No.	Diameter (mm)	Mass of Sieve (g)	Mass retained (sieve + soil) (g)	% Retained	% Passing
4	4.75	515.7	515.7	0%	100%
10	2	490.7	491	0%	100%
20	0.85	412.6	465.5	18%	82%
40	0.425	381.9	428.2	15%	67%
60	0.25	366.8	391.8	8%	59%
140	0.106	342.5	375.3	11%	48%
200	0.075	338.7	359.8	7%	41%
Pan		364	487.6	41%	

% Passing = 100 - % Retained

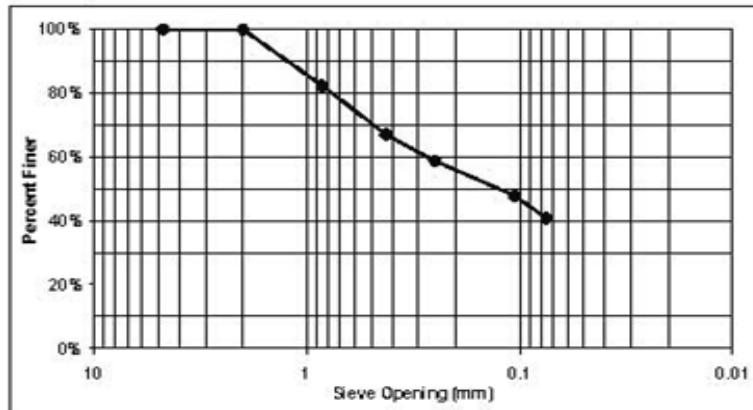

Detailed soils analysis



The University of New Mexico

UNIVERSITY OF NEW MEXICO
DEPARTMENT OF CIVIL ENGINEERING

GRAIN SIZE ANALYSIS

Urban Flood Demonstration Project
Project

ENE (Badger E)
Boring Identification

I. Pedro & C. LeJeune
Tested By

5** 9 1
Pan No. Soil Bag No. Sieve Set

December 8, 2006
Date of Testing

Brown Sand w/Clay
Field Description of Soil

185.4
Mass of Dry Sample (g), M

37.5 - 43
Depth of Sample (m)

**Washed Material

Sieve No.	Diameter (mm)	Mass of Sieve (g)	Mass retained (sieve + soil) (g)	% Retained	% Passing
4	4.75	503.2	503.2	0%	100%
10	2	464.4	468	2%	98%
20	0.85	413.1	423.5	6%	92%
40	0.425	370	378.8	5%	88%
60	0.25	354	360	3%	84%
140	0.106	342	351.9	5%	79%
200	0.075	327.7	335.6	4%	75%
Pan		364	502.5	75%	

% Passing = 100 - % Retained

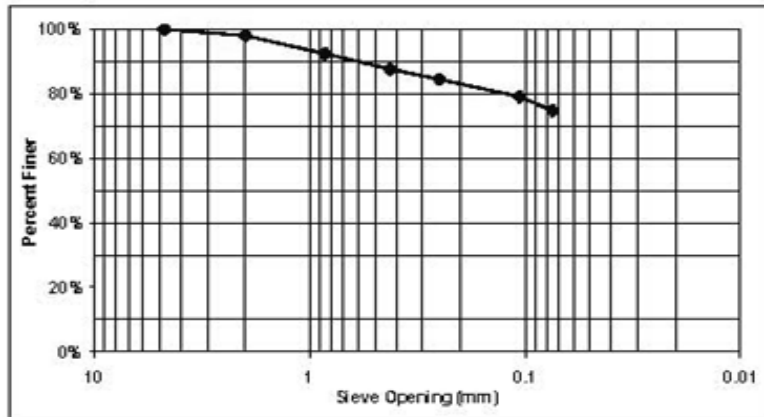

Detailed soils analysis



UNIVERSITY OF NEW MEXICO
DEPARTMENT OF CIVIL ENGINEERING

GRAIN SIZE ANALYSIS

Urban Flood Demonstration Project
Project

ENE (Badger E)
Boring Identification

I. Pedro
Tested By

6* 11 1
Pan No. Soil Bag No. Sieve Set

December 6, 2006
Date of Testing

Brown Sand w/Clay
Field Description of Soil

251
Mass of Dry Sample (g), M

45 - 49.5
Depth of Sample (m)

*Non-Washed Material

Sieve No.	Diameter (mm)	Mass of Sieve (g)	Mass retained (sieve + soil) (g)	% Retained	% Passing
4	4.75	503.2	503.2	0%	100%
10	2	464.4	464.5	0%	100%
20	0.85	413.1	415.4	1%	99%
40	0.425	370	378.6	3%	96%
60	0.25	354	382.9	12%	84%
140	0.106	342	464.6	49%	35%
200	0.075	327.7	365.7	15%	20%
Pan		364	416.3	20%	

% Passing = 100 - % Retained

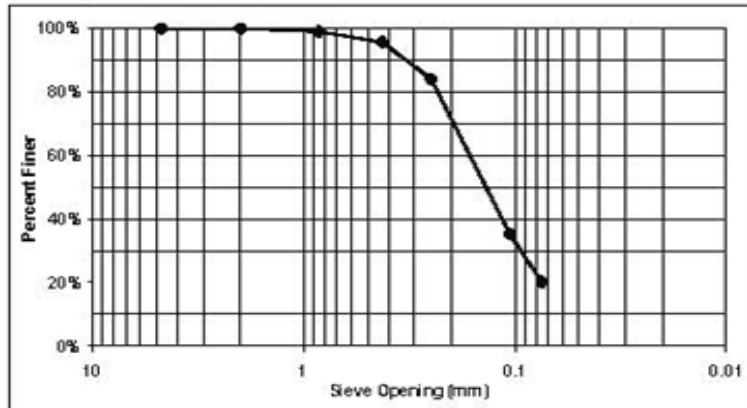

Detailed soils analysis



The University of New Mexico

UNIVERSITY OF NEW MEXICO
DEPARTMENT OF CIVIL ENGINEERING

GRAIN SIZE ANALYSIS

Urban Flood Demonstration Project
Project

ENE (Badger E)
Boring Identification

L. Pedro & C. LaJeune
Tested By

6** 11 2
Pan No. Soil Bag No. Sieve Set

December 8, 2006
Date of Testing

Brown Sand w/Clay
Field Description of Soil

153.5
Mass of Dry Sample (g), M

45 - 49.5
Depth of Sample (m)

**Washed Material

Sieve No.	Diameter (mm)	Mass of Sieve (g)	Mass retained (sieve + soil) (g)	% Retained	% Passing
4	4.75	515.7	515.7	0%	100%
10	2	490.7	490.8	0%	100%
20	0.85	412.6	414.1	1%	99%
40	0.425	381.9	386	3%	96%
60	0.25	366.8	383.7	11%	85%
140	0.106	342.5	403.9	40%	45%
200	0.075	338.7	356.3	11%	34%
Pan		364	414.6	34%	

% Passing = 100 - % Retained

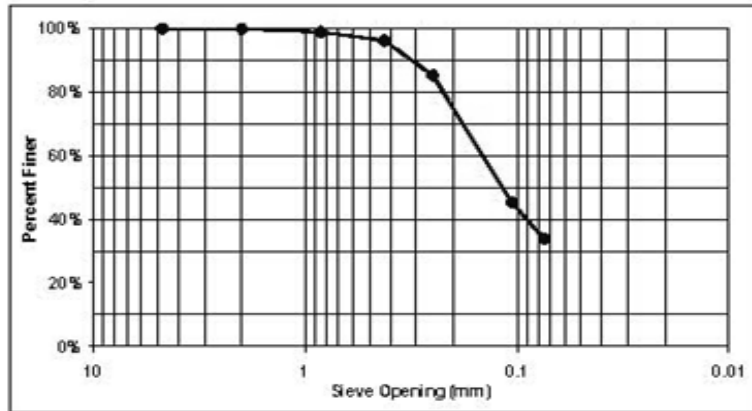

Detailed soils analysis



The University of New Mexico

UNIVERSITY OF NEW MEXICO
DEPARTMENT OF CIVIL ENGINEERING

GRAIN SIZE ANALYSIS

Urban Flood Demonstration Project
Projec

ENE (Badger E)
Boring Identification

L. Pedro
Tested By

7 Pan No. 14 Soil Bag No. 1 Sieve Set

December 6, 2006
Date of Testing

Light Brown Sand
Field Description of Soil

454.8
Mass of Dry Sample (g), M

60.5 - 66
Depth of Sample (m)

Sieve No.	Diameter (mm)	Mass of Sieve (g)	Mass retained (sieve + soil) (g)	% Retained	% Passing
4	4.75	503.2	503.5	0%	100%
10	2	464.4	467.9	1%	99%
20	0.85	413.1	426.4	3%	96%
40	0.425	370	438.1	15%	81%
60	0.25	354	499.1	32%	49%
140	0.106	342	535.7	43%	7%
200	0.075	327.7	343.5	3%	3%
Pan		364	379.6	3%	

% Passing = 100 - % Retained



Detailed soils analysis



The University of New Mexico

UNIVERSITY OF NEW MEXICO
DEPARTMENT OF CIVIL ENGINEERING

GRAIN SIZE ANALYSIS

Urban Flood Demonstration Project
Projec

ENE (Badger E)
Boring Identification

I. Pedro
Tested By

8 16 2
Pan No. Soil Bag No. Sieve Set

December 6, 2006
Date of Testing

Light Brown Sand
Field Description of Soil

665.2
Mass of Dry Sample (g), M

66 - 78.5
Depth of Sample (in)

Sieve No.	Diameter (mm)	Mass of Sieve (g)	Mass retained (sieve + soil) (g)	% Retained	% Passing
4	4.75	515.7	516.8	0%	100%
10	2	490.7	493.9	0%	99%
20	0.85	412.6	433	3%	96%
40	0.425	381.9	475.6	14%	82%
60	0.25	366.8	609.8	37%	46%
140	0.106	342.5	633	44%	2%
200	0.075	338.7	346.1	1%	1%
Pan		364	370.2	1%	

% Passing = 100 - % Retained

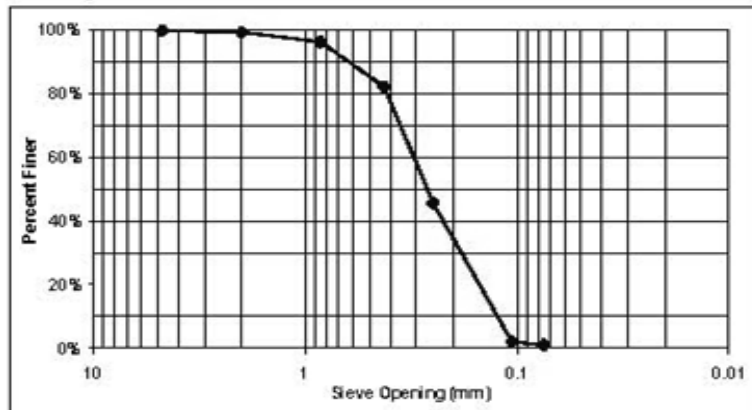

Detailed soils analysis



UNIVERSITY OF NEW MEXICO
DEPARTMENT OF CIVIL ENGINEERING

GRAIN SIZE ANALYSIS

Urban Flood Demonstration Project
Projec

ENE (Badger E)
Boring Identification

I. Pedro
Tested By

9 Pan No. 17 Soil Bag No. 1 Sieve Set

December 6, 2006
Date of Testing

Sand w/Gravel
Field Description of Soil

594.2
Mass of Dry Sample (g), M

78.5 - 83.5
Depth of Sample (m)

Sieve No.	Diameter (mm)	Mass of Sieve (g)	Mass retained (sieve + soil) (g)	% Retained	% Passing
4	4.75	503.2	551.2	8%	92%
10	2	464.4	490.2	4%	88%
20	0.85	413.1	470.1	10%	78%
40	0.425	370	523.9	26%	52%
60	0.25	354	517.2	27%	25%
140	0.106	342	475.6	22%	2%
200	0.075	327.7	335.4	1%	1%
Pan		364	369.1	1%	

% Passing = 100 - % Retained

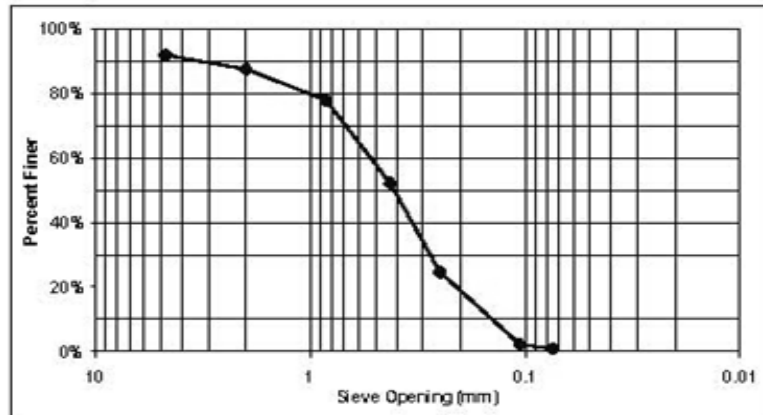

Detailed soils analysis



The University of New Mexico

UNIVERSITY OF NEW MEXICO
DEPARTMENT OF CIVIL ENGINEERING

GRAIN SIZE ANALYSIS

Urban Flood Demonstration Project
Projec

ENE (Badger E)
Boring Identification

I. Pedro
Tested By

10 20 2
Pan No. Soil Bag No. Sieve Set

December 6, 2006
Date of Testing

Sand w/Gravel
Field Description of Soil

786.6
Mass of Dry Sample (g), M

95 - 100
Depth of Sample (ft)

Sieve No.	Diameter (mm)	Mass of Sieve (g)	Mass retained (sieve + soil) (g)	% Retained	% Passing
4	4.75	515.7	698.4	23%	77%
10	2	490.7	505.2	2%	75%
20	0.85	412.6	448.2	5%	70%
40	0.425	381.9	572.6	24%	46%
60	0.25	366.8	610.8	31%	15%
140	0.106	342.5	450.2	14%	1%
200	0.075	338.7	344.2	1%	1%
Pan		364	368.9	1%	

% Passing = 100 - % Retained

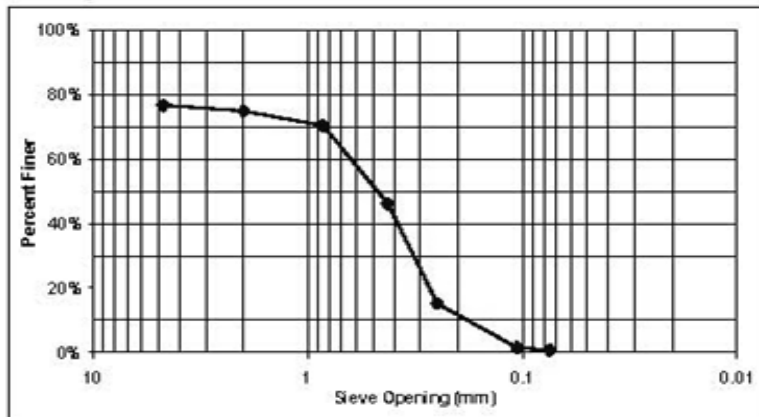

Detailed soils analysis



The University of New Mexico

UNIVERSITY OF NEW MEXICO
DEPARTMENT OF CIVIL ENGINEERING

GRAIN SIZE ANALYSIS

Urban Flood Demonstration Project
Projec

ENE (Badger E)
Boring Identification

I. Pedro
Tested By

11 24 1
Pan No. Soil Bag No. Sieve Set

December 6, 2006
Date of Testing

Light Brown Sand
Field Description of Soil

538.6
Mass of Dry Sample (g), M

116.5 - 120
Depth of Sample (n)

Sieve No.	Diameter (mm)	Mass of Sieve (g)	Mass retained (sieve + soil) (g)	% Retained	% Passing
4	4.75	503.2	503.8	0%	100%
10	2	464.4	469.9	1%	99%
20	0.85	413.1	423.6	2%	97%
40	0.425	370	459.7	17%	80%
60	0.25	354	585.9	43%	37%
140	0.106	342	532.5	35%	2%
200	0.075	327.7	333.7	1%	1%
Pan		364	367.7	1%	

% Passing = 100 - % Retained

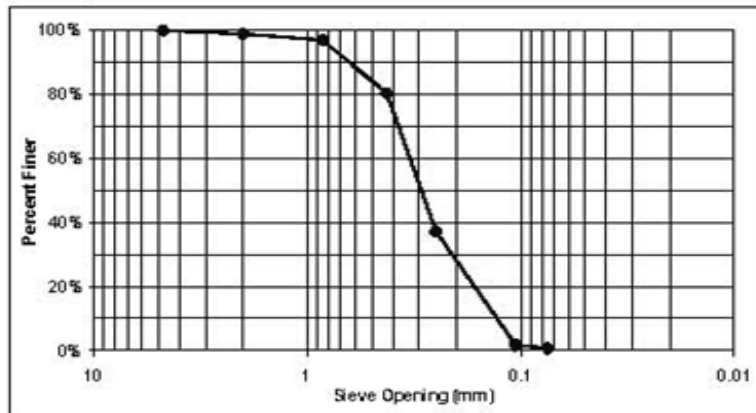

Detailed soils analysis



UNIVERSITY OF NEW MEXICO
DEPARTMENT OF CIVIL ENGINEERING

HYDROMETER ANALYSIS

The University of New Mexico

Project		Requested by		Date
Urban Flood Demonstration Project		J. Pedro		14 Mar-2007
Soiling identification	Cylinder #	Depth (cm)	Time	Sample #1. @
ENE	6	0 - 7.5	11:40 AM	50.0
Specific Gravity	Moisture Content (%)		Notes	
2.70	18.5		Soil Bag 1, Pan 1	

MENISCUS CORRECTION (m)	<u>6</u>
G _s CORRECTION FACTOR (α)	<u>0.99</u>
SUSPENSION CONSTANT (k)	<u>0.01361</u>
CORRECTED SAMPLE WT. (W _s)	<u>40.8</u>
PERCENT PASSING #200 SIEVE	<u>60%</u>

Elapsed Time (min)	Hydrometer Reading		Temperature (°C)	Effective Depth (cm)		Particle Diameter (mm)	% Finer (%)
	Orig.	R _s		R _{s(Com)}	Corrected		
2	30	24	19	12.4	12.2760	0.0337	35.0%
5	23	17	19	13.5	13.3650	0.0223	24.8%
10	21	15	19	13.8	13.6620	0.0159	21.9%
15	19	13	19	14.2	14.0680	0.0132	18.9%
20	18	12	20	14.3	14.1570	0.0115	17.5%
30	17	11	18	14.5	14.3650	0.0094	16.0%
60	16	10	19	14.7	14.630	0.0067	14.6%
250	14	8	19	15.0	14.8500	0.0033	11.7%
1440	11	5	19	15.5	15.3450	0.0014	7.3%

Detailed soils analysis



UNIVERSITY OF NEW MEXICO
DEPARTMENT OF CIVIL ENGINEERING

HYDROMETER ANALYSIS

The University of New Mexico

Project Urban Flood Demonstration Project		Issued By J. Pedra		Date 20-Mar-2007
Boring Identification ENE	Cylinder # 2	Depth (m) 13.5 - 19.5	Time 11:18 AM	Sample Wt. (g) 50.0
Specific Gravity 2.70	Moisture Content (%) 18.8	Notes Soil Bag 3, Pan 3		

MENISCUS CORRECTION (m)	<u>0</u>
G _s CORRECTION FACTOR (α)	<u>0.99</u>
SUSPENSION CONSTANT (k)	<u>0.01328</u>
CORRECTED SAMPLE WGT. (W _s)	<u>40.6</u>
PERCENT PASSING #200 SIEVE	<u>88%</u>

Elapsed Time (min)	Hydrometer Reading		Temperature (°C)	Effective Depth (cm)		Particle Diameter (mm)	% Finer (%)
	Orig.	R _s		R _{s(Corr)}	Corrected		
2	33	33	22	10.9	10.7910	0.0308	70.8%
5	31	31	22	11.2	11.0880	0.0198	66.5%
10	30	30	22	11.4	11.2860	0.0141	64.4%
15	24	24	21	12.4	12.2760	0.0120	51.5%
20	22	22	21	12.7	12.5730	0.0105	47.2%
30	19	19	21	13.2	13.0680	0.0088	40.8%
60	17	17	20	13.5	13.3650	0.0063	36.5%
250	15	15	20	13.8	13.6620	0.0031	32.2%
1440	14	14	19	14.0	13.8600	0.0013	30.0%

Detailed soils analysis



UNIVERSITY OF NEW MEXICO
DEPARTMENT OF CIVIL ENGINEERING

HYDROMETER ANALYSIS

The University of New Mexico

Project		Analyst		Date	
Urban Flood Demonstration Project		J. Pedro		20-Mar-2007	
Boring Identification	Cylinder #	Depth (ft)	Time	Sample #1 (g)	
ENE	3	37.5 - 43	11:30 AM	50.0	
Specific Gravity	Moisture Content (%)		Notes		
2.70	13.5		Soil Bag 9, Pan 5		

MENISCUS CORRECTION (m)	<u>0</u>
G _s CORRECTION FACTOR (α)	<u>0.99</u>
SUSPENSION CONSTANT (k)	<u>0.01328</u>
CORRECTED SAMPLE WT. (W _s)	<u>43.3</u>
PERCENT PASSING #200 SIEVE	<u>75%</u>

Elapsed Time (min)	Hydrometer Reading		Temperature (°C)	Effective Depth (cm)		Particle Diameter (mm)	% Finer (%)
	Orig.	R _s		R _{s(Corr)}	Corrected		
2	35	35	22	10.6	10.4940	0.0304	60.1%
5	32	32	21	11.1	10.9890	0.0197	54.9%
10	30	30	21	11.4	11.2860	0.0141	51.5%
15	26	26	21	12.0	11.8800	0.0118	44.6%
20	25	25	20	12.2	12.0780	0.0103	42.9%
30	24	24	20	12.4	12.2760	0.0085	41.2%
60	22	22	21	12.7	12.5730	0.0061	37.8%
250	19	19	21	13.2	13.0680	0.0030	32.6%
1440	17	17	18	13.5	13.3650	0.0013	29.2%

Detailed soils analysis



UNIVERSITY OF NEW MEXICO
DEPARTMENT OF CIVIL ENGINEERING

GRAIN SIZE ANALYSIS

Urban Flood Demonstration Project
Project
I. Pedro
Tested By

ENE (Badger E)
Boring Identification
1 1
Pan No. Soil Bag

Sieve No.	Diameter (mm)	% Passing
4	4.75	100%
10	2	100%
20	0.85	98%
40	0.425	92%
60	0.25	85%
140	0.106	69%
200	0.075	60%
	0.0337	35.0%
	0.0223	24.8%
	0.0159	21.9%
	0.0132	18.9%
	0.0115	17.5%
	0.0094	16.0%
	0.0067	14.6%
	0.0033	11.7%
	0.0014	7.3%

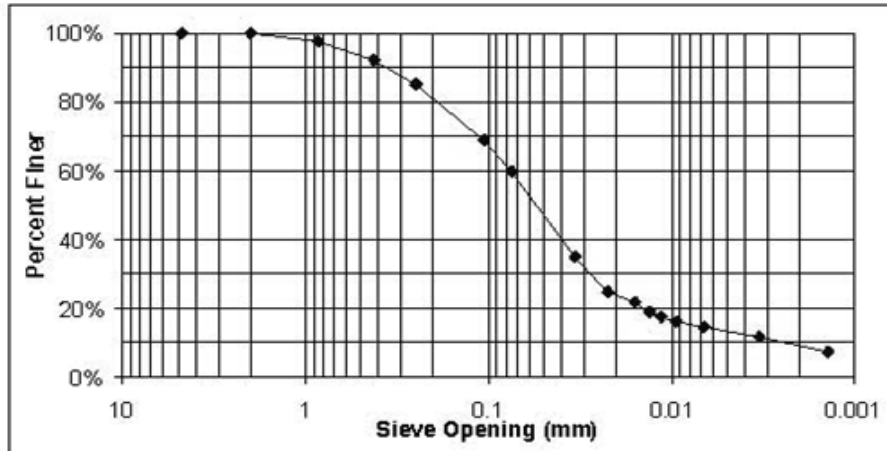

Detailed soils analysis



UNIVERSITY OF NEW MEXICO
DEPARTMENT OF CIVIL ENGINEERING

GRAIN SIZE ANALYSIS

The University of New Mexico

Urban Flood Demonstration Project
Project
I. Pedro
Tested By

ENE (Badger E)
Boring Identification
3 3
Pan No. Soil Bag

Sieve No.	Diameter (mm)	% Passing
4	4.75	100%
10	2	100%
20	0.85	99%
40	0.425	98%
60	0.25	97%
140	0.106	93%
200	0.075	88%
	0.0308	70.8%
	0.0198	66.5%
	0.0141	64.4%
	0.0120	51.5%
	0.0105	47.2%
	0.0088	40.8%
	0.0063	36.5%
	0.0031	32.2%
	0.0013	30.0%

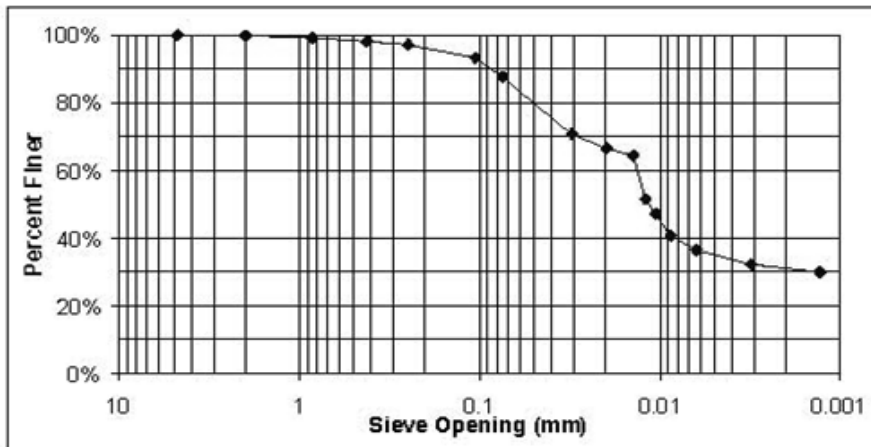

Detailed soils analysis



UNIVERSITY OF NEW MEXICO
DEPARTMENT OF CIVIL ENGINEERING

GRAIN SIZE ANALYSIS

The University of New Mexico

Urban Flood Demonstration Project
Project
I. Pedro
Tested By

ENE (Badger E)
Boring Identification
5 9
Pan No. Soil Bag

Sieve No.	Diameter (mm)	% Passing
4	4.75	100%
10	2	98%
20	0.85	92%
40	0.425	88%
60	0.25	84%
140	0.106	79%
200	0.075	75%
	0.0304	60.1%
	0.0197	54.9%
	0.0141	51.5%
	0.0118	44.6%
	0.0103	42.9%
	0.0085	41.2%
	0.0061	37.8%
	0.0030	32.6%
	0.0013	29.2%

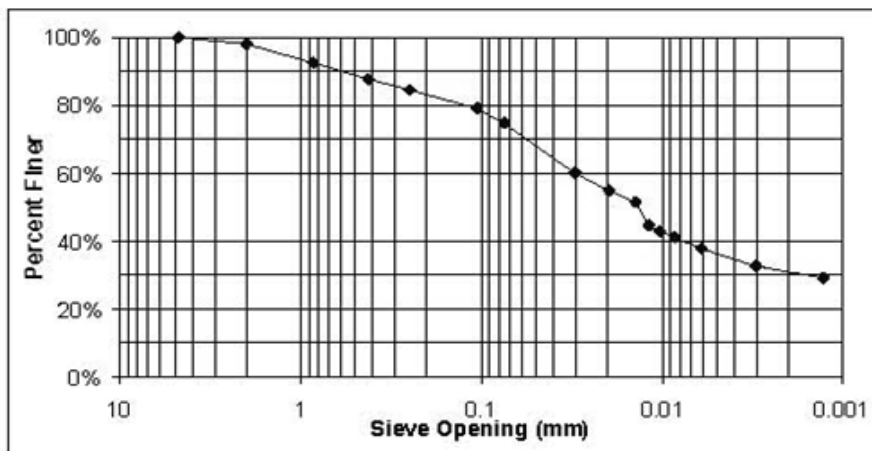

Detailed soils analysis



UNIVERSITY OF NEW MEXICO
DEPARTMENT OF CIVIL ENGINEERING

SOIL WASHING ANALYSIS

January 6* & 9, 2007
Date of Washing
January 7* & 10, 2007
Date of Weighing
EN (Badger)
Boring Identification

J. Pedro & C. LeJeune
Name

FROM WATER CONTENT ANALYSIS

Boring Identification	ENN		ENC			ENW	
	Pan						
Pan	3	4	11	12	14	1	2
Boring Bag	5	7	7	9	13	1	2
Mass of Dry Soil (g)	718.4	684.7	221.5	395.5	288.0	471.8	408.5
Bowl	A	B	C	D	E	A	B
WASHED AND DRIED							
Pan	10	11	7	8	9	1	2
Mass of Pan + Dry Soil (g)	463.4	459.7	217.0	176.5	321.7	343.3	346.2
Mass of Pan (g)	139.4	137.6	137.8	138.0	139.4	139.2	138.6
Mass of Dry Soil (g)	324.0	322.1	79.2	38.5	182.3	204.1	207.6
Mass of Fines (g)	394.4	362.6	142.3	357.0	105.7	267.7	200.9

FROM WATER CONTENT ANALYSIS

Boring Identification	ENE*					
	1	2	3	4	5	6
Pan	1	2	3	4	5	6
Boring Bag	1					
Mass of Dry Soil (g)	108.6	158.6	173.5	185.3	185.4	153.5
Bowl	A	B	C	D	E	F
WASHED AND DRIED						
Pan	1	2	3	4	5	6
Mass of Pan + Dry Soil (g)	190.4	196.9	173.4	192.2	195.8	249.2
Mass of Pan (g)	139.2	138.6	139.1	139.2	138.9	139.0
Mass of Dry Soil (g)	51.2	58.3	34.3	53.0	56.9	110.2
Mass of Fines (g)	57.4	100.3	139.2	132.3	128.5	43.3

Detailed soils analysis

Appendix G: Diversion (ED10) Core Data Sheets



UNIVERSITY OF NEW MEXICO
DEPARTMENT OF CIVIL ENGINEERING

SOIL BORING LOG INFORMATION

PAGE 1 of 1

The University of New Mexico

Project Name Urban Flood Demonstration Project		Boring Classification ID ECN		Date of Drilling 18-Aug-06		Corresponding Well ID Diversion (ED10) North		
Boring Drilled By J. Pedro & C. LeJeune		Canopy Rain Gage N/A		Open Rain Gage N/A		Weather Cloudy		
Boring Location 3 Feet SW of Well		# of Soil Bags Collected 14		Water Table Depth N/A		Final Depth 78.5"		
						Well Elevation 88'		
						Temperature 85 F		
SAMPLE	DESCRIPTION (Visual-Manual Method)							COMMENTS
DEPTH (ft)	NUMBER	MOISTURE	COLOR	DRY STRENGTH	DILATANCY	TOUGHNESS	PLASTICITY	
0	0	D	Bm					Clear surface
6	1	M	Bm	L	S	M	H	Sandy clay appearance
7.5	2	M	LBm	N	R	L	N	Sandy appearance
14.5	3	M	LBm	N	R	L	N	
21.5	4	M	LBm	N	R	L	N	
28	5	M	LBm	N	R	L	N	
33.5	6	M	LBm	N	R	L	N	
39.5	7	M	LBm	N	R	L	N	
45.5	8	M	LBm	N	R	L	N	
51.5	9	M	LBm	N	R	L	N	Coarser sandy appearance
59	10	M	LBm	N	R	L	N	Same as above with pebbles present
65.5	11	VM	LBm	N	R	L	N	Same as above with gravel present black organic material streaks present
71.5	12	VM	Tan	N	R	L	N	Finer-grained sandier appearance
77.5	13	VM	Tan	N	R	L	N	
78.5	14	VM	Tan	N	R	L	N	Gravel present. Unable to advance any further, either encountered big boulder or jetti jack.
								**Material likely to remain the same until water table was reached
I hereby certify that the information of this form is true and correct to the best of my knowledge								
Signature			Print Name			Date		

Detailed soils analysis



UNIVERSITY OF NEW MEXICO
DEPARTMENT OF CIVIL ENGINEERING

WATER CONTENT DETERMINATION

The University of New Mexico

Urban Flood Demonstration Program
Project

I. Pedro
Tested By

January 12, 2007
Date of Testing

January 13, 2007
Date of Dry Weighing

ECN (Diversion N)
Boring Identification

CONTAINER NO. (CUP)	1*	2	5	6	7		
FIELD TEXTURE	OM	L.B. Sand	L.B. Sand	L.B. Sand	Sand w/Gravel		
BORING BAG NO.	1	3	9	11	13		
DEPTH (in)	0 - 8	7.5 - 14.5	45.5 - 51.5	59 - 65.5	71.5 - 77.5		
MASS OF CUP + WET SOIL (g)	621.8	796.5	813.1	1066.3	847.2		
MASS OF CUP + DRY SOIL (g)	571.5	779.8	764.8	1043.6	794.2		
MASS OF CUP (g)	139.2	138.6	138.9	139.0	137.8		
MASS OF DRY SOIL, Ms (g)	432.3	641.2	625.9	904.6	656.4		
MASS OF WATER, Mw (g)	50.3	16.7	48.3	22.7	53.0		
WATER CONTENT, w (%)	11.6%	2.6%	7.7%	2.5%	8.1%		

CONTAINER NO. (CUP)							
FIELD TEXTURE							
BORING BAG NO.							
DEPTH (in)							
MASS OF CUP + WET SOIL (g)							
MASS OF CUP + DRY SOIL (g)							
MASS OF CUP (g)							
MASS OF DRY SOIL, Ms (g)							
MASS OF WATER, Mw (g)							
WATER CONTENT, w (%)							

$$w = \frac{M_w}{M_s} (100) \%$$

Detailed soils analysis



The University of New Mexico

UNIVERSITY OF NEW MEXICO
DEPARTMENT OF CIVIL ENGINEERING

GRAIN SIZE ANALYSIS

Urban Flood Demonstration Program

ECN (Diversion N)

Projec

Boring Identification

I. Pedro

1* 1 2

Tested By

Pan No. Soil Bag No. Sieve No.

January 16, 2007

OM

Date of Testing

Field Description of Soil

432.3

0 - 6

Mass of Dry Sample, M_d

Depth of Sample (in)

Sieve No.	Diameter (mm)	Mass of Sieve (g)	Mass retained (sieve + soil) (g)	% Retained	% Passing
4	4.75	515.7	515.7	0%	100%
10	2	490.7	492.1	0%	100%
20	0.85	412.6	417.1	1%	99%
40	0.425	381.9	398.9	4%	95%
60	0.25	366.8	412.2	11%	84%
140	0.106	342.5	471.7	30%	54%
200	0.075	338.7	365.1	6%	48%
Pan		364.0	571.7	48%	

*Washed Material

% Passing = 100 - Σ% Retained

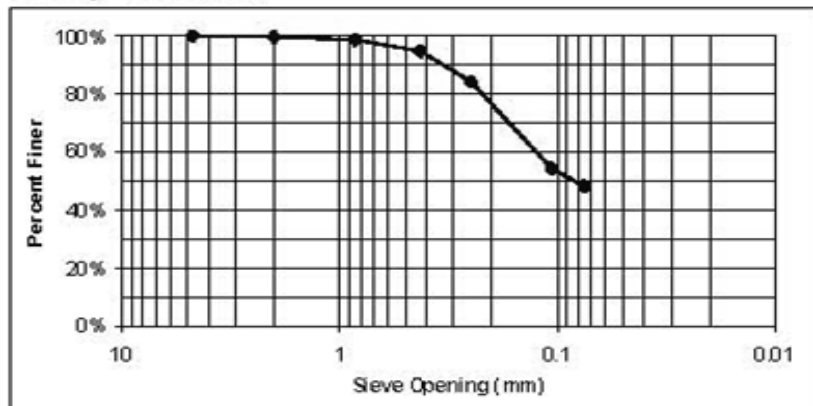

Detailed soils analysis



UNIVERSITY OF NEW MEXICO
DEPARTMENT OF CIVIL ENGINEERING

GRAIN SIZE ANALYSIS

The University of New Mexico

Urban Flood Demonstration Program

ECN (Diversion N)

Projec

Boring Identification

I. Pedro

2 3 2

Tested By

Pan No. Soil Bag No. Sieve No.

January 13, 2007

Light Brown Sand

Date of Testing

Field Description of Soil

641.2

7.5 - 14.5

Mass of Dry Sample, M_s

Depth of Sample (in)

Sieve No.	Diameter (mm)	Mass of Sieve (g)	Mass retained (sieve + soil) (g)	% Retained	% Passing
4	4.75	515.7	516.4	0%	100%
10	2	490.7	494.4	1%	99%
20	0.85	412.6	434.2	3%	96%
40	0.425	381.9	515.8	21%	75%
60	0.25	366.8	631.4	41%	34%
140	0.106	342.5	546.6	32%	2%
200	0.075	338.7	347.8	1%	1%
Pan		364.0	367.4	1%	

% Passing = 100 - Σ% Retained

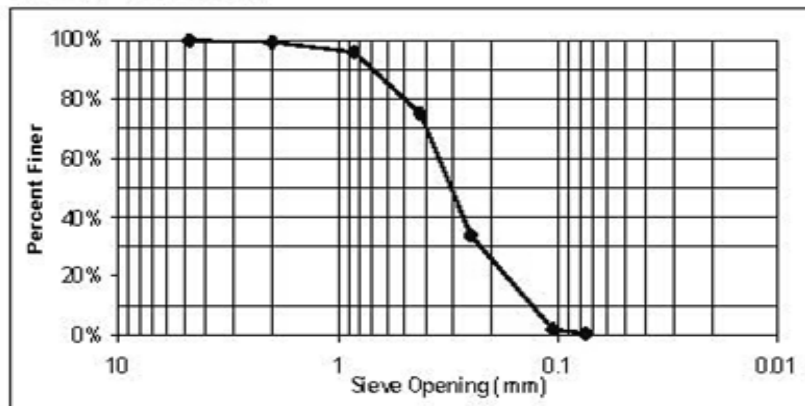

Detailed soils analysis



The University of New Mexico

UNIVERSITY OF NEW MEXICO
DEPARTMENT OF CIVIL ENGINEERING

GRAIN SIZE ANALYSIS

Urban Flood Demonstration Program
Project

ECN (Diversion N)
Boiling Identification

I. Pedro
Tested By

5 9 1
Pan No. Soil Bag No. Sieve No.

January 13, 2007
Date of Testing

Light Brown Sand
Field Description of Soil

625.9
Mass of Dry Sample, M_s

45.5 - 51.5
Depth of Sample (m)

Sieve No.	Diameter (mm)	Mass of Sieve (g)	Mass retained (sieve + soil) (g)	% Retained	% Passing
4	4.75	503.2	510.3	1%	99%
10	2	464.4	498.9	6%	93%
20	0.85	413.1	477.7	10%	83%
40	0.425	370.0	522.4	24%	59%
60	0.25	354.0	584.4	37%	22%
140	0.106	342.0	475.3	21%	1%
200	0.075	327.7	329.6	1%	0%
Pan		364.0	366.0	0%	

% Passing = 100 - Σ% Retained

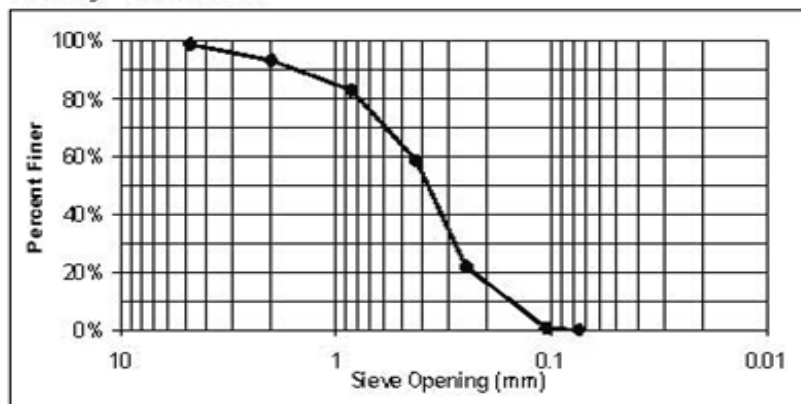

Detailed soils analysis



The University of New Mexico

UNIVERSITY OF NEW MEXICO
DEPARTMENT OF CIVIL ENGINEERING

GRAIN SIZE ANALYSIS

Urban Flood Demonstration Program
Project

ECN (Diversion N)
Boeing Identification

I. Pedro
Tested By

6 11 2
Pan No. Soil Bag No. Sieve No.

January 13, 2007
Date of Testing

Light Brown Sand
Field Description of Soil

904.6
Mass of Dry Sample, M_s

59 - 65.5
Depth of Sample (in)

Sieve No.	Diameter (mm)	Mass of Sieve (g)	Mass retained (sieve + soil) (g)	% Retained	% Passing
4	4.75	515.7	595.2	9%	91%
10	2	490.7	564.2	8%	83%
20	0.85	412.6	603.0	21%	62%
40	0.425	381.9	651.1	30%	32%
60	0.25	366.8	568.0	22%	10%
140	0.106	342.5	431.2	10%	0%
200	0.075	338.7	340.2	0%	0%
Pan		364.0	365.0	0%	

% Passing = 100 - Σ% Retained

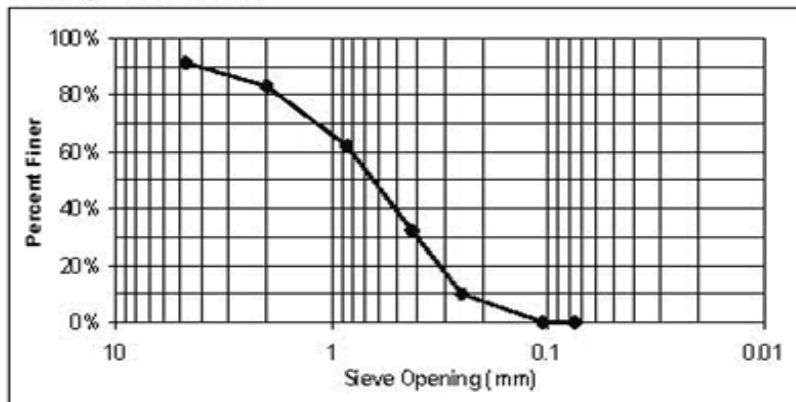

Detailed soils analysis



The University of New Mexico

UNIVERSITY OF NEW MEXICO
DEPARTMENT OF CIVIL ENGINEERING

GRAIN SIZE ANALYSIS

Urban Flood Demonstration Program

ECN (Diversion N)

Projec

Boing Identification

I. Pedro

7 13 1

Tested By

Pan No. Soil Bag No. Sieve No.

January 13, 2007

Light Brown Sand

Date of Testing

Field Description of Soil

656.4

71.5 - 77.5

Mass of Dry Sample, M_d

Depth of Sample (in)

Sieve No.	Diameter (mm)	Mass of Sieve (g)	Mass retained (sieve + soil) (g)	% Retained	% Passing
4	4.75	503.2	506.4	0%	100%
10	2	464.4	466.8	0%	99%
20	0.85	413.1	419.5	1%	98%
40	0.425	370.0	397.4	4%	94%
60	0.25	354.0	718.1	55%	39%
140	0.106	342.0	591.2	38%	1%
200	0.075	327.7	330.4	1%	0%
Pan		364.0	365.8	0%	

% Passing = 100 - Σ% Retained

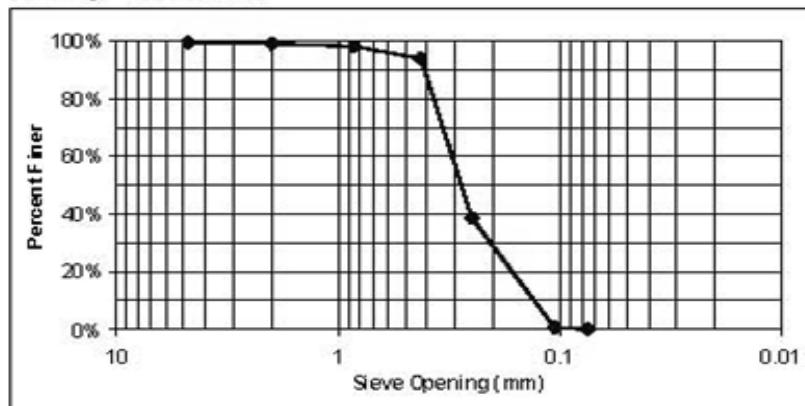

Detailed soils analysis



The University of New Mexico

UNIVERSITY OF NEWMEXICO
DEPARTMENT OF CIVIL ENGINEERING

HYDROMETER ANALYSIS

Project Urban Flood Demonstration Project		Prepared By J. Pedro		Date 3-Apr-2007
Boring Identification ECN	Cylinder # 4	Depth (m) 0-6	Time 12:25 PM	Sample Wt (g) 50.0
Specific Gravity 2.70	Moisture Content (%) 11.6	Notes Soil Bag 1, Pan 1		

MENISCUS CORRECTION (m)	4
G _s CORRECTION FACTOR (α)	0.99
SUSPENSION CONSTANT (K)	0.01328
CORRECTED SAMPLE WT. (W _s)	44.2
PERCENT PASSING #200 SIEVE	48%

Elapsed Time (min)	Hydrometer Reading		Temperature (°C)	Effective Depth (cm)		Particle Diameter (mm)	% Finer (%)
	Orig.	R _s		R _{a(Corr)}	Corrected		
2	40	36	21	10.4	10.2960	0.0301	38.7%
5	38	34	21	10.7	10.5930	0.0193	36.6%
10	35	31	21	11.2	11.0880	0.0140	33.3%
15	32	28	21	11.7	11.5830	0.0117	30.1%
20	31	27	21	11.9	11.7810	0.0102	29.0%
30	29	25	21	12.2	12.0780	0.0084	26.9%
60	25	21	21	12.9	12.7710	0.0061	22.6%
250	21	17	21	13.5	13.3650	0.0031	18.3%
1440	18	14	19	14.0	13.8600	0.0013	15.1%

Detailed soils analysis



UNIVERSITY OF NEW MEXICO
DEPARTMENT OF CIVIL ENGINEERING

GRAIN SIZE ANALYSIS

The University of New Mexico

Urban Flood Demonstration Project
Project
I. P edro
Tested By

ECN (Diversion N)
Boring Identification
1 1
Pan No. Soil Bag

Sieve No.	Diameter (mm)	% Passing
4	4.75	100%
10	2	100%
20	0.85	99%
40	0.425	95%
60	0.25	84%
140	0.106	54%
200	0.075	48%
	0.0301	38.7%
	0.0193	36.6%
	0.0140	33.3%
	0.0117	30.1%
	0.0102	29.0%
	0.0084	26.9%
	0.0061	22.6%
	0.0031	18.3%
	0.0013	15.1%

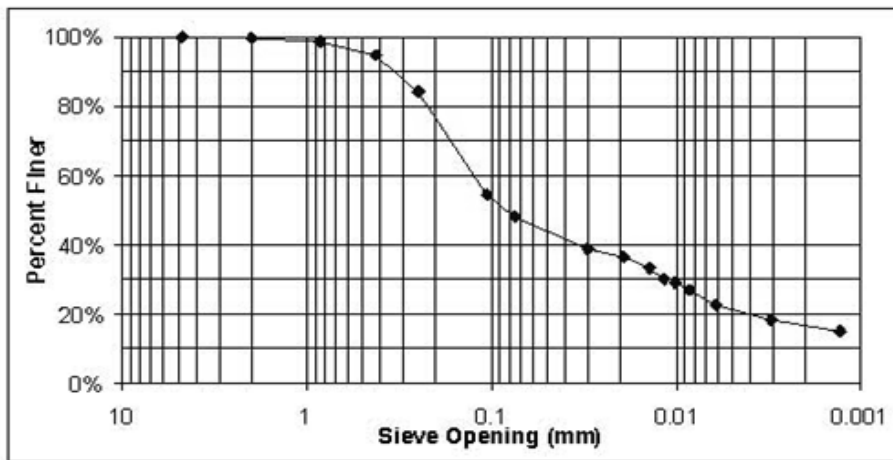

Detailed soils analysis



UNIVERSITY OF NEW MEXICO
DEPARTMENT OF CIVIL ENGINEERING

SOIL BORING LOG INFORMATION

PAGE 1 of 1

The University of New Mexico

Project Name Urban Flood Demonstration Project		Boring Classification ID ECW		Date of Drilling 23-Aug-06		Corresponding Well ID Diversion (ED10) West		
Boring Drilled By I. Pedro & C. LeJeune		Canopy Rain Gage 1.15"		Open Rain Gage 1.25"		Weather Cloudy		
Boring Location 3 Feet SW of Well		# of Soil Bags Collected 15		Water Table Depth 77.5"		Final Depth 79"		
				Well Elevation 78.75"		Temperature 98 F		
DEPTH (ft)	SAMPLE NUMBER	DESCRIPTION (Visual-Manual Method)						COMMENTS
		MOISTURE	COLOR	DRY STRENGTH	DILATANCY	TOUGHNESS	PLASTICITY	
0	0	VM	DBm					Green vegetation with decomposition organic material and leaves present
7	1	VM	DBm	M	R	L	L	Organic material with a clayey presence
10	2	VM	DBm	M	R	M	M	
14	3	VM	Brn	L	R	L	L	Sandy appearance
21	4	VM	Bm	L	R	L	L	
25.5	5	VM	LBm	N	R	L	N	
31.5	6	M	LBm	N	R	L	N	Encountered roots. Small amount of gravel present with a sandy coarser appearance
39.5	7	M	LBm	N	R	L	N	Same as above with more gravel appearance
44	8	M	LBm	N	R	L	N	
49.5	9	M	LBm	N	R	L	N	Encountered roots
54	10	M	LBm	N	R	L	N	
60	11	M	LBm	N	R	L	N	More larger gravel present
64	12	VM	LBm	N	R	L	N	Encountered roots
67.5	13	VM	LBm	N	R	L	N	
73.5	14	VM	LBm	N	R	L	N	coarser appearance
79	15	W	LBm					Water table reached @ 77.5". Too saturated for VMM testing
								**Rained earlier in the day
I hereby certify that the information of this form is true and correct to the best of my knowledge								
Signature				Print Name		Date		
				Isaiah Pedro / Chnstian LeJeune		23-Aug-06		

Detailed soils analysis



UNIVERSITY OF NEW MEXICO
DEPARTMENT OF CIVIL ENGINEERING

WATER CONTENT DETERMINATION

The University of New Mexico

Urban Flood Demonstration Program
Project

I. Pedro
Tested By

January 11, 2007
Date of Testing

January 12, 2007
Date of Dry Weighing

ECW (Diversion W)
Boring Identification

CONTAINER NO. (CUP)	10*	11	12	13	14		
FIELD TEXTURE	OM w/Clay	B. Sand	L.B. Sand	L.B. Sand	L.B. Sand		
BORING BAG NO.	1	4	6	10	14		
DEPTH (in)	0 - 7	14 - 21	25.5 - 31.5	49.5 - 54	67.5 - 73.5		
MASS OF CUP + WET SOIL (g)	563.3	741.3	803.2	803.7	895.3		
MASS OF CUP + DRY SOIL (g)	483.8	700.8	772.9	792.2	848.8		
MASS OF CUP (g)	139.4	137.6	137.2	138.6	138.3		
MASS OF DRY SOIL, M _s (g)	344.4	563.2	635.7	653.6	710.5		
MASS OF WATER, M _w (g)	79.5	40.5	30.3	11.5	46.5		
WATER CONTENT, w (%)	23.1%	7.2%	4.8%	1.8%	6.5%		

CONTAINER NO. (CUP)							
FIELD TEXTURE							
BORING BAG NO.							
DEPTH (in)							
MASS OF CUP + WET SOIL (g)							
MASS OF CUP + DRY SOIL (g)							
MASS OF CUP (g)							
MASS OF DRY SOIL, M _s (g)							
MASS OF WATER, M _w (g)							
WATER CONTENT, w (%)							

$$w = \frac{M_w}{M_s} (100) \%$$

Detailed soils analysis



UNIVERSITY OF NEW MEXICO
DEPARTMENT OF CIVIL ENGINEERING

GRAIN SIZE ANALYSIS

The University of New Mexico

Urban Flood Demonstration Program

ECW (Diversion W)

Projec

Boing Identification

I. Pedro

10*

Tested By

1

2

January 13, 2007

OM w/Clay

Date of Testing

Field Description of Soil

344.4

0 - 7

Mass of Dry Sample, M_s

Depth of Sample (m)

*Washed Material

Sieve No.	Diameter (mm)	Mass of Sieve (g)	Mass retained (sieve + soil) (g)	% Retained	% Passing
4	4.75	515.7	515.7	0%	100%
10	2	490.7	491.2	0%	100%
20	0.85	412.6	413.5	0%	100%
40	0.425	381.9	383.7	1%	99%
60	0.25	366.8	371.2	1%	98%
140	0.106	342.5	383.8	12%	86%
200	0.075	338.7	391.2	15%	71%
Pan		364.0	608.3	71%	

% Passing = 100 - Σ% Retained

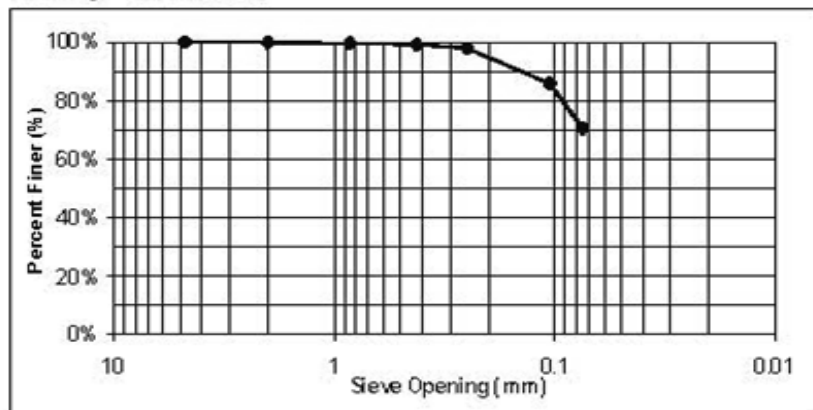

Detailed soils analysis



UNIVERSITY OF NEW MEXICO
DEPARTMENT OF CIVIL ENGINEERING

GRAIN SIZE ANALYSIS

The University of New Mexico

Urban Flood Demonstration Program

ECW (Diversion W)

Projec

Boiling Identification

I. Pedro

11 4 1

Tested By

Pan No. Soil Bag No. Sieve No.

January 12, 2007

Brown Sand

Date of Testing

Field Description of Soil

563.2

14 - 21

Mass of Dry Sample, M_d

Depth of Sample (m)

Sieve No.	Diameter (mm)	Mass of Sieve (g)	Mass retained (sieve + soil) (g)	% Retained	% Passing
4	4.75	503.2	506.2	1%	99%
10	2	464.4	479.2	3%	97%
20	0.85	413.1	428.7	3%	94%
40	0.425	370.0	409.8	7%	87%
60	0.25	354.0	477.4	22%	65%
140	0.106	342.0	629.1	51%	14%
200	0.075	327.7	365.6	7%	7%
Pan		364.0	407.0	7%	

% Passing = 100 - Σ% Retained

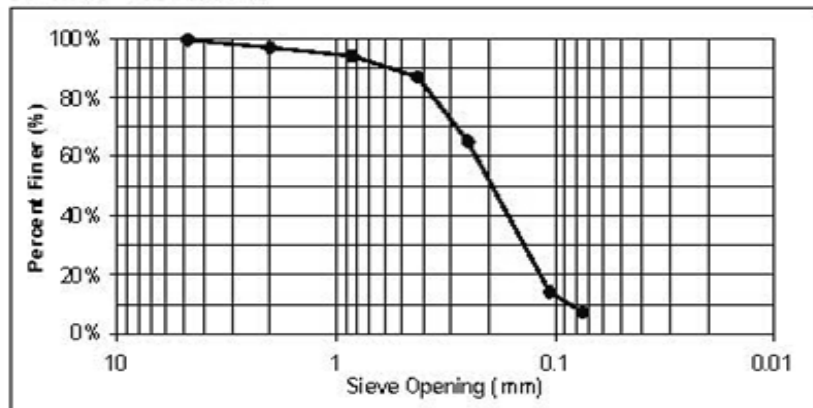

Detailed soils analysis



UNIVERSITY OF NEW MEXICO
DEPARTMENT OF CIVIL ENGINEERING

GRAIN SIZE ANALYSIS

The University of New Mexico

Urban Flood Demonstration Program

ECW (Diversion W)

Projec

Boing Identification

I. Pedro
Tested By

12 6 2
Pan No. Soil Bag No. Sieve No.

January 12, 2007
Date of Testing

Light Brown Sand
Field Description of Soil

635.7
Mass of Dry Sample, M_s

25.5 - 31.5
Depth of Sample (in)

Sieve No.	Diameter (mm)	Mass of Sieve (g)	Mass retained (sieve + soil) (g)	% Retained	% Passing
4	4.75	515.7	528.1	2%	98%
10	2	490.7	510.9	3%	95%
20	0.85	412.6	440.2	4%	91%
40	0.425	381.9	468.4	14%	77%
60	0.25	366.8	619.3	40%	37%
140	0.106	342.5	559.4	34%	3%
200	0.075	338.7	348.2	1%	2%
Pan		364.0	374.6	2%	

% Passing = 100 - % Retained

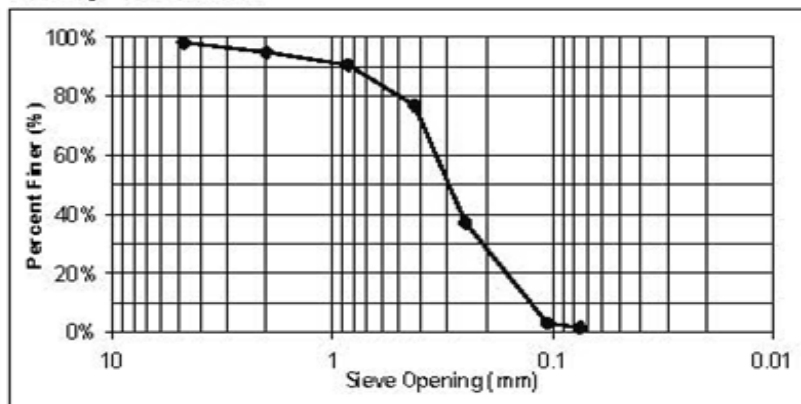

Detailed soils analysis



The University of New Mexico

UNIVERSITY OF NEW MEXICO
DEPARTMENT OF CIVIL ENGINEERING

GRAIN SIZE ANALYSIS

Urban Flood Demonstration Program
Project

ECW (Diversion W)
Boiling Identification

I. Pedro
Tested By

13 10 1
Pan No. Soil Bag No. Sieve No.

January 12, 2007
Date of Testing

Light Brown Sand
Field Description of Soil

653.6
Mass of Dry Sample, M_s

49.5 - 54
Depth of Sample (in)

Sieve No.	Diameter (mm)	Mass of Sieve (g)	Mass retained (sieve + soil) (g)	% Retained	% Passing
4	4.75	503.2	549.4	7%	93%
10	2	464.4	474.5	2%	91%
20	0.85	413.1	443.5	5%	87%
40	0.425	370.0	547.0	27%	60%
60	0.25	354.0	591.0	36%	23%
140	0.106	342.0	487.8	22%	1%
200	0.075	327.7	331.6	1%	0%
Pan		364.0	367.4	0%	

% Passing = 100 - Σ% Retained

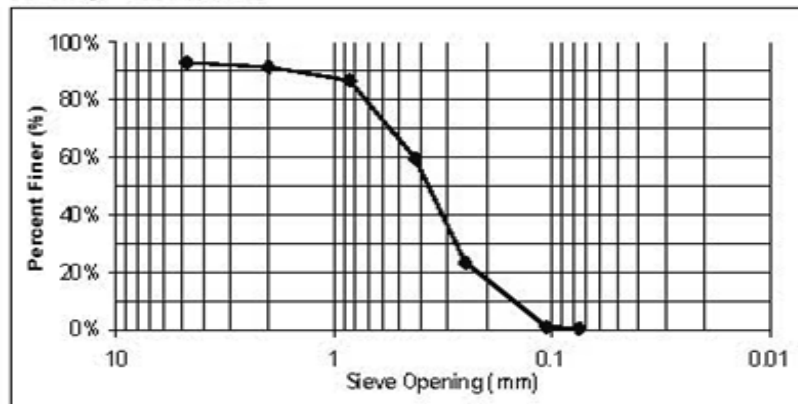

Detailed soils analysis



UNIVERSITY OF NEW MEXICO
DEPARTMENT OF CIVIL ENGINEERING

GRAIN SIZE ANALYSIS

The University of New Mexico

Urban Flood Demonstration Program
Projec

ECW (Diversion W)
Boing Identification

I. Pedro
Tested By

14 14 2
Pan No. Soil Bag No. Sieve No.

January 12, 2007
Date of Testing

Light Brown Sand
Field Description of Soil

710.5
Mass of Dry Sample, M_s

67.5 - 73.5
Depth of Sample (in)

Sieve No.	Diameter (mm)	Mass of Sieve (g)	Mass retained (sieve + soil) (g)	% Retained	% Passing
4	4.75	515.7	612.3	14%	86%
10	2	490.7	551.7	9%	78%
20	0.85	412.6	516.9	15%	63%
40	0.425	381.9	531.7	21%	42%
60	0.25	366.8	527.3	23%	19%
140	0.106	342.5	472.9	18%	1%
200	0.075	338.7	342.3	1%	0%
Pan		364.0	367.1	0%	

% Passing = 100 - Σ% Retained

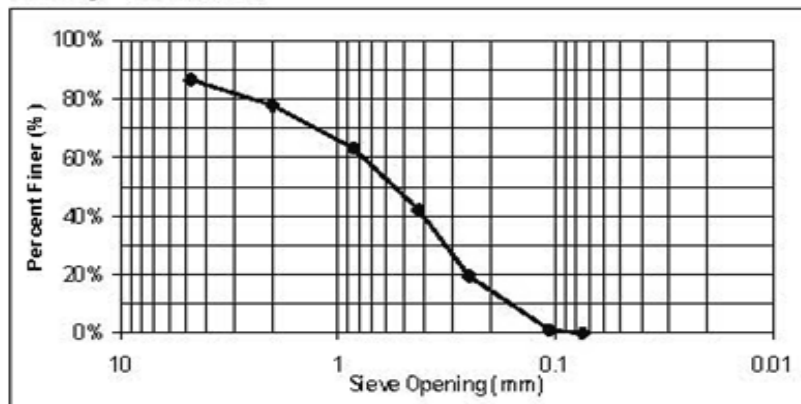

Detailed soils analysis



The University of New Mexico

UNIVERSITY OF NEWMEXICO
DEPARTMENT OF CIVIL ENGINEERING

HYDROMETER ANALYSIS

Project Urban Flood Demonstration Project		Issued By J. Pedro		Date 27-Mar-2007
Soiling Identification ECW	Cylinder # 6	Depth (ft) 0 - 7	Time 1:35 PM	Sample Weight 50.0
Specific Gravity 2.70	Moisture Content (%) 23.1	Notes Soil Bag 1, Pan 10		

MENISCUS CORRECTION (m)	<u>1</u>
G _s CORRECTION FACTOR (α)	<u>0.99</u>
SUSPENSION CONSTANT (K)	<u>0.01361</u>
CORRECTED SAMPLE WT. (W _s)	<u>38.5</u>
PERCENT PASSING #200 SIEVE	<u>71%</u>

Elapsed Time (min)	Hydrometer Reading		Temperature (°C)	Effective Depth (cm)		Particle Diameter (mm)	% Finer (%)
	Orig.	R _s		R _{s(Corr)}	Corrected		
2	16	15	19	13.8	13.6620	0.0356	27.4%
5	15	14	19	14.0	13.8600	0.0227	25.6%
10	14	13	20	14.2	14.0680	0.0161	23.8%
15	14	13	19	14.2	14.0680	0.0132	23.8%
20	13	12	19	14.3	14.1570	0.0115	21.9%
30	13	12	20	14.3	14.1570	0.0093	21.9%
60	13	12	21	14.3	14.1570	0.0066	21.9%
250	13	12	19	14.3	14.1570	0.0032	21.9%
1440	13	12	18	14.3	14.1570	0.0013	21.9%

Detailed soils analysis



UNIVERSITY OF NEW MEXICO
DEPARTMENT OF CIVIL ENGINEERING

GRAIN SIZE ANALYSIS

The University of New Mexico

Urban Flood Demonstration Project
Project
I. Pedro
Tested By

ECW (Diversion W)
Boring Identification
10 1
Pan No. Soil Bag

Sieve No.	Diameter (mm)	% Passing
4	4.75	100%
10	2	100%
20	0.85	100%
40	0.425	99%
60	0.25	98%
140	0.106	86%
200	0.075	71%
	0.0356	27.4%
	0.0227	25.6%
	0.0161	23.8%
	0.0132	23.8%
	0.0115	21.9%
	0.0093	21.9%
	0.0066	21.9%
	0.0032	21.9%
	0.0013	21.9%

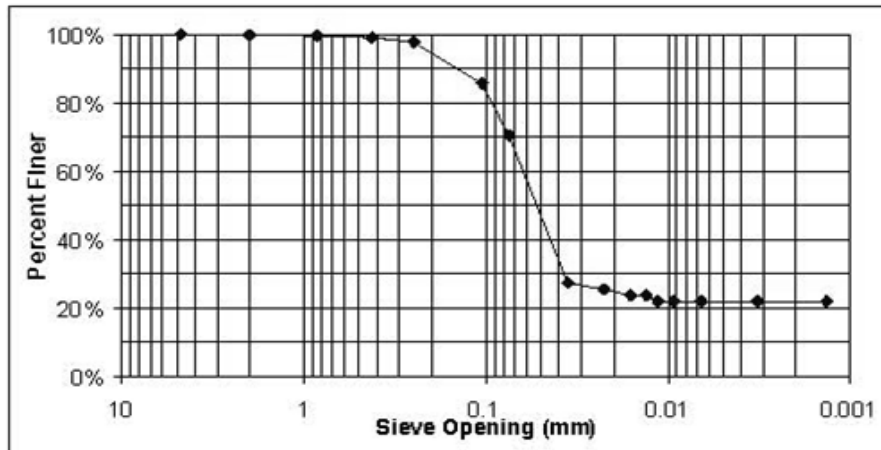

Detailed soils analysis



UNIVERSITY OF NEW MEXICO
DEPARTMENT OF CIVIL ENGINEERING

SOIL BORING LOG INFORMATION

PAGE 1 of 1

The University of New Mexico

Project Name Urban Flood Demonstration Project		Boring Classification ID ECC		Date of Drilling 18-Aug-06		Corresponding Well ID Diversion (ED10) Center		
Boring Drilled By I. Pedro & C. LeJeune		Canopy Rain Gage N/A		Open Rain Gage N/A		Weather Overcast		
Boring Location 8 Feet SW of Well		# of Soil Bags Collected 17		Water Table Depth 81"		Final Depth 83"		
				Well Casing Depth 80"		Temperature 85 F		
SAMPLE	DESCRIPTION (Visual-Manual Method)							COMMENTS
DEPTH (IN)	NUMBER	MOISTURE	COLOR	DRY STRENGTH	DILATANCY	TOUGHNESS	PLASTICITY	
0	0	D	Bm					No vegetation or organic material present
4	1	M	Bm	H	S	M	M	Organic material and roots present Sandy appearance
7	2	M	LBm	M	R	L	N	↓
12	3	M	LBm	L	R	L	N	Sandy appearance
17	4	M	Tan	L	R	L	N	More sandier appearance
23	5	M	Tan	L	R	L	N	↓
28	6	M	Tan	L	R	L	N	↓
31	7	M	Tan	L	R	L	N	↓
33	8	M	Tan	L	R	L	N	Coarser sandy appearance
38	9	M	Tan	L	R	L	N	Finer sandier appearance
45	10	M	Tan	L	R	L	N	↓
51	11	M	Tan	L	R	L	N	↓
55	12	M	Tan	L	R	L	N	Black streaks for organic material present
59.5	13	M	Tan	L	R	L	N	↓
65	14	VM	Tan	L	R	L	N	Coarser sandy appearance
71	15	VM	LBm	L	R	L	N	Same as above with black streaks of organic material present
76.5	16	VM	LBm	L	R	L	N	↓
83	17	VM	LBm	L	R	L	N	Coarser sandy appearance with gravel present Water table reached @ 81"
I hereby certify that the information of this form is true and correct to the best of my knowledge								
Signature		Print Name				Date		
		Isaiah Pedro / Christian LeJeune				18-Aug-06		

Detailed soils analysis



UNIVERSITY OF NEW MEXICO
DEPARTMENT OF CIVIL ENGINEERING

WATER CONTENT DETERMINATION

The University of New Mexico

Urban Flood Demonstration Program
Project

I. Pedro
Tested By

January 12, 2007
Date of Testing

January 13, 2007
Date of Dry Weighing

ECC (Diversion C)
Boring Identification

CONTAINER NO. (CUP)	8	9	11	12	13		
FIELD TEXTURE	DM	B. Sand	L.B. Sand	L.B. Sand	L.B. Sand		
BORING BAG NO.	1	3	4	10	15		
DEPTH (in)	0 - 4	7 - 12	12 - 17	38 - 45	65 - 71		
MASS OF CUP + WET SOIL (g)	409.8	748.9	725.2	839.3	1009.7		
MASS OF CUP + DRY SOIL (g)	395.3	741.9	717.3	834.3	953.3		
MASS OF CUP (g)	138.0	139.4	137.6	137.2	138.6		
MASS OF DRY SOIL, Ms (g)	257.3	602.5	579.7	497.1	814.7		
MASS OF WATER, Mw (g)	14.5	7.0	7.9	5.0	56.4		
WATER CONTENT, w (%)	5.6%	1.2%	1.4%	1.0%	6.9%		

CONTAINER NO. (CUP)							
FIELD TEXTURE							
BORING BAG NO.							
DEPTH (in)							
MASS OF CUP + WET SOIL (g)							
MASS OF CUP + DRY SOIL (g)							
MASS OF CUP (g)							
MASS OF DRY SOIL, Ms (g)							
MASS OF WATER, Mw (g)							
WATER CONTENT, w (%)							

$$w = \frac{M_w}{M_s} (100) \%$$

Detailed soils analysis



The University of New Mexico

UNIVERSITY OF NEW MEXICO
DEPARTMENT OF CIVIL ENGINEERING

GRAIN SIZE ANALYSIS

Urban Flood Demonstration Program
Projec

ECC (Diversion C)
Boing Identification

I. Pedro
Tested By

8 Pan No. 1 Soil Bag No. 1 Sieve No.

January 13, 2007
Date of Testing

OM
Field Description of Soil

257.3
Mass of Dry Sample, M_s

0 - 4
Depth of Sample (in)

Sieve No.	Diameter (mm)	Mass of Sieve (g)	Mass retained (sieve + soil) (g)	% Retained	% Passing
4	4.75	503.2	503.2	0%	100%
10	2	464.4	469.0	2%	98%
20	0.85	413.1	432.1	7%	91%
40	0.425	370.0	427.0	22%	69%
60	0.25	354.0	449.4	37%	32%
140	0.106	342.0	400.4	23%	9%
200	0.075	327.7	334.4	3%	6%
Pan		364.0	379.5	6%	

% Passing = 100 - Σ% Retained

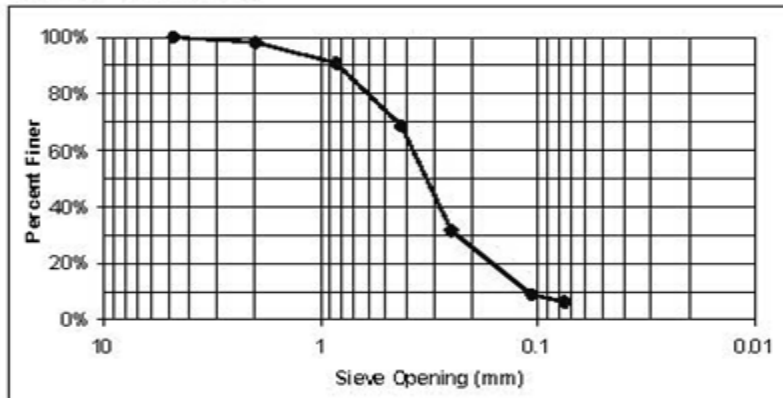

Detailed soils analysis



UNIVERSITY OF NEW MEXICO
DEPARTMENT OF CIVIL ENGINEERING

GRAIN SIZE ANALYSIS

The University of New Mexico

Urban Flood Demonstration Program
Project

ECC (Diversion C)
Boing Identification

I. Pedro
Tested By

9 Pan No. 3 Soil Bag No. 2 Sieve No.

January 13, 2007
Date of Testing

Brown Sand
Field Description of Soil

602.5
Mass of Dry Sample, M_s

7 - 12
Depth of Sample (in)

Sieve No.	Diameter (mm)	Mass of Sieve (g)	Mass retained (sieve + soil) (g)	% Retained	% Passing
4	4.75	515.7	519.5	1%	99%
10	2	490.7	492.1	0%	99%
20	0.85	412.6	419.8	1%	98%
40	0.425	381.9	433.6	9%	89%
60	0.25	366.8	582.5	36%	54%
140	0.106	342.5	643.4	50%	4%
200	0.075	338.7	351.8	2%	1%
Pan		364.0	372.1	1%	

% Passing = 100 - Σ% Retained

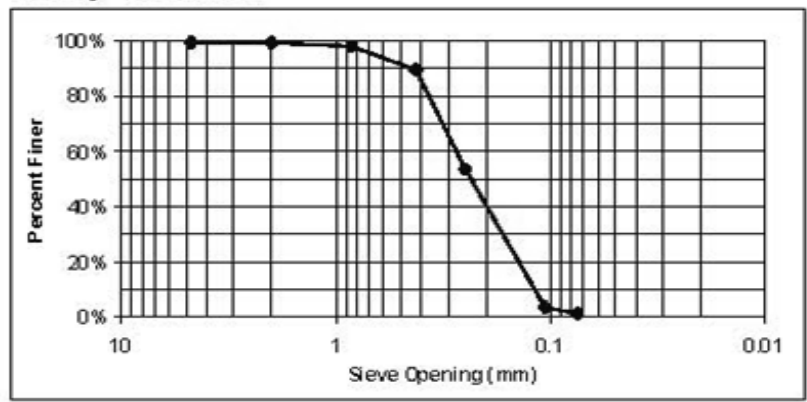

Detailed soils analysis



UNIVERSITY OF NEW MEXICO
DEPARTMENT OF CIVIL ENGINEERING

GRAIN SIZE ANALYSIS

The University of New Mexico

Urban Flood Demonstration Program

ECC (Diversion C)

Projec

Boring Identification

I. Pedro

11 Pan No. 4 Soil Bag No. 1 Sieve No.

Tested By

January 13, 2007

Light Brown Sand

Date of Testing

Field Description of Soil

579.7

12 - 17

Mass of Dry Sample, M_s

Depth of Sample (m)

Sieve No.	Diameter (mm)	Mass of Sieve (g)	Mass retained (sieve + soil) (g)	% Retained	% Passing
4	4.75	503.2	503.4	0%	100%
10	2	464.4	464.7	0%	100%
20	0.85	413.1	414.1	0%	100%
40	0.425	370.0	377.8	1%	98%
60	0.25	354.0	430.9	13%	85%
140	0.106	342.0	790.5	77%	8%
200	0.075	327.7	356.3	5%	3%
Pan		364.0	380.4	3%	

% Passing = 100 - Σ% Retained

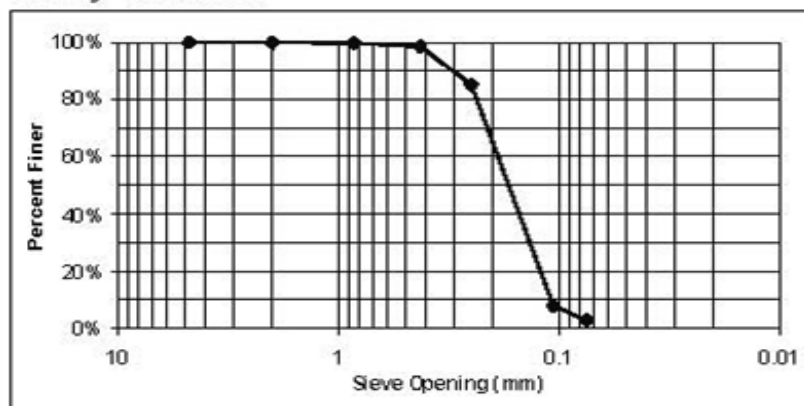

Detailed soils analysis



The University of New Mexico

UNIVERSITY OF NEW MEXICO
DEPARTMENT OF CIVIL ENGINEERING

GRAIN SIZE ANALYSIS

Urban Flood Demonstration Program

Projec

ECC (Diversion C)

Boing Identification

J. Pedro

Tested By

12

Pan No.

10

Soil Bag No.

2

Sieve No.

January 13, 2007

Date of Testing

Light Brown Sand

Field Description of Soil

497.1

Mass of Dry Sample, M_s

38 - 45

Depth of Sample (n)

Sieve No.	Diameter (mm)	Mass of Sieve (g)	Mass retained (sieve + soil) (g)	% Retained	% Passing
4	4.75	515.7	515.8	0%	100%
10	2	490.7	490.9	0%	100%
20	0.85	412.6	415.1	1%	99%
40	0.425	381.9	439.0	11%	88%
60	0.25	366.8	539.5	35%	53%
140	0.106	342.5	572.6	46%	7%
200	0.075	338.7	359.5	4%	3%
Pan		364.0	377.0	3%	

% Passing = 100 - Σ% Retained

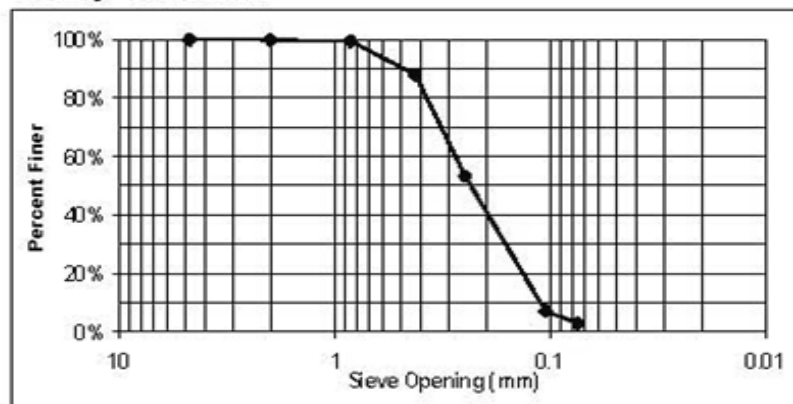

Detailed soils analysis



The University of New Mexico

UNIVERSITY OF NEW MEXICO
DEPARTMENT OF CIVIL ENGINEERING

GRAIN SIZE ANALYSIS

Urban Flood Demonstration Program
Projec

ECC (Diversion C)
Boing Identification

I. Pedro
Tested By

13 15 1
Pan No. Soil Bag No. Sieve No.

January 13, 2007
Date of Testing

Light Brown Sand
Field Description of Soil

814.7
Mass of Dry Sample, M_s

65 - 71
Depth of Sample (in)

Sieve No.	Diameter (mm)	Mass of Sieve (g)	Mass retained (sieve + soil) (g)	% Retained	% Passing
4	4.75	503.2	504.0	0%	100%
10	2	464.4	464.9	0%	100%
20	0.85	413.1	417.7	1%	99%
40	0.425	370.0	443.7	9%	90%
60	0.25	354.0	769.3	51%	39%
140	0.106	342.0	648.3	38%	2%
200	0.075	327.7	336.7	1%	1%
Pan		364.0	368.2	1%	

% Passing = 100 - Σ% Retained

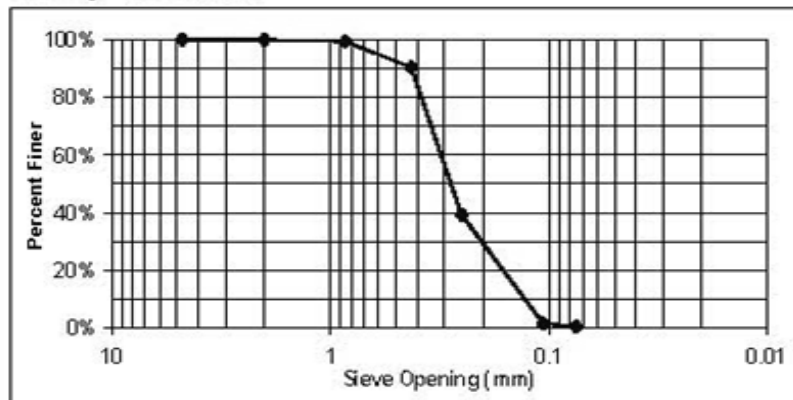

Detailed soils analysis



The University of New Mexico

UNIVERSITY OF NEW MEXICO
DEPARTMENT OF CIVIL ENGINEERING

SOIL BORING LOG INFORMATION

PAGE 1 of 1

Project Name Urban Flood Demonstration Project		Boring Classification ID ECE		Date of Drilling 16-Aug-06		Corresponding Well ID Diversion (ED10) East		
Boring Drilled By I. Pedro & C. LeJeune		Canopy Rain Gage N/A		Open Rain Gage N/A		Weather Sunny		
Boring Location 12 Feet SW of Well		# of Soil Bags Collected 17		Water Table Depth 109"		Final Depth 109.5"		
				Well Bore Depth 109"		Reminders Note N/A		
DEPTH (ft)	SAMPLE NUMBER	DESCRIPTION (Visual-Manual Method)						COMMENTS
		MOISTURE	COLOR	DRY STRENGTH	DILATANCY	TOUGHNESS	PLASTICITY	
0	0	M	Bm					Organic material, twigs and leaves present
7	1	M	Bm	M	S	L	L	Organic material with a sandy appearance
13	2	M	Bm	M	R	L	L	↓
17	3	M	Brn	L	R	L	M	Organic material present
24	4	M	Bm	L	S	L	L	
31.5	5	M	LBm	L	S	L	N	
37.5	6	M	LBm	L	S	L	N	
45.5	7	M	LBm	L	S	L	N	
51.5	8	M	LBm	L	S	L	N	
60	9	M	LBm	L	S	L	N	
67	10	M	LBm	L	S	L	N	
73	11	VM	LBm	L	S	L	N	
80	12	VM	Bm	L	S	L	N	↓
87.5	13	VM	Bm					Too saturated for VMM testing
94	14	VM	Bm					Coarse sand appearance
100	15	VM	Bm					↓
106	16	VM	Bm					Coarse sand appearance with gravel present
109.5	17	W	Bm					↓
<p>I hereby certify that the information of this form is true and correct to the best of my knowledge</p>								
Signature				Print Name		Date		
				Isaiah Pedro / Christian LeJeune		16-Aug-06		

Detailed soils analysis



UNIVERSITY OF NEW MEXICO
DEPARTMENT OF CIVIL ENGINEERING

WATER CONTENT DETERMINATION

The University of New Mexico

Urban Flood Demonstration Program
Project

J. Pedro
Tested By

January 11, 2007
Date of Testing

January 12, 2007
Date of Dry Weighing

ECE (Diversion E)
Boring Identification

CONTAINER NO. (CUP)	3*	4*	5	6	7	8	9
FIELD TEXTURE	OM	B. Sand	L.B. Sand	L.B. Sand	L.B. Sand	B. Sand	B. Sand
BORING BAG NO.	1	3	5	9	11	12	16
DEPTH (in)	0 - 7	13 - 17	24 - 31.5	51.5 - 60	67 - 73	73 - 80	100 - 106
MASS OF CUP + WET SOIL (g)	684.0	510.2	845.8	927.3	918.3	1080.2	1018.5
MASS OF CUP + DRY SOIL (g)	594.5	457.0	821.8	909.0	884.6	1024.3	889.0
MASS OF CUP (g)	139.1	139.2	138.9	139.0	137.8	138.0	139.4
MASS OF DRY SOIL, M _s (g)	455.4	317.8	682.9	770.0	746.8	886.3	749.6
MASS OF WATER, M _w (g)	89.5	53.2	24.0	18.3	33.7	55.9	129.5
WATER CONTENT, w (%)	19.7%	16.7%	3.5%	2.4%	4.5%	6.3%	17.3%

CONTAINER NO. (CUP)							
FIELD TEXTURE							
BORING BAG NO.							
DEPTH (in)							
MASS OF CUP + WET SOIL (g)							
MASS OF CUP + DRY SOIL (g)							
MASS OF CUP (g)							
MASS OF DRY SOIL, M _s (g)							
MASS OF WATER, M _w (g)							
WATER CONTENT, w (%)							

$$w = \frac{M_w}{M_s} (100) \%$$

Detailed soils analysis



UNIVERSITY OF NEW MEXICO
DEPARTMENT OF CIVIL ENGINEERING

GRAIN SIZE ANALYSIS

The University of New Mexico

Urban Flood Demonstration Program

ECE (Diversion E)

Projec

Boing Identification

I. Pedro

3* 1 2
Pan No. Soil Bag No. Sieve No.

Tested By

January 13, 2007

OM

Date of Testing

Field Description of Soil

455.4
Mass of Dry Sample, M_s

0 - 7
Depth of Sample (in)

Sieve No.	Diameter (mm)	Mass of Sieve (g)	Mass retained (sieve + soil) (g)	% Retained	% Passing
4	4.75	515.7	515.7	0%	100%
10	2	490.7	491.8	0%	100%
20	0.85	412.6	423.4	2%	97%
40	0.425	381.9	398.9	4%	94%
60	0.25	366.8	381.3	3%	90%
140	0.106	342.5	369.8	6%	84%
200	0.075	338.7	362.1	5%	79%
Pan		364.0	727.4	79%	
Washed			265.5		

*Material washed

% Passing = 100 - Σ% Retained

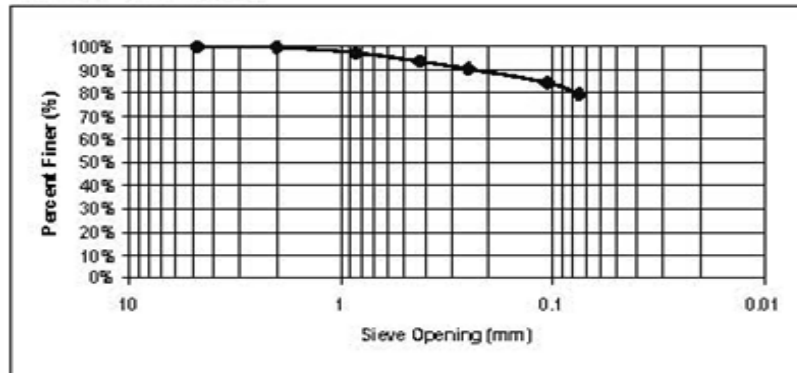

Detailed soils analysis



The University of New Mexico

UNIVERSITY OF NEW MEXICO
DEPARTMENT OF CIVIL ENGINEERING

GRAIN SIZE ANALYSIS

Urban Flood Demonstration Program
Project

ECE (Diversion E)
Boing Identification

I. Pedro
Tested By

4* 3 1
Pan No. Soil Bag No. Sieve No.

January 13, 2007
Date of Testing

Brown Sand
Field Description of Soil

317.8
Mass of Dry Sample, M_s

13 - 17
Depth of Sample (m)

Sieve No.	Diameter (mm)	Mass of Sieve (g)	Mass retained (sieve + soil) (g)	% Retained	% Passing
4	4.75	503.2	503.1	0%	100%
10	2	464.4	464.6	0%	100%
20	0.85	413.1	417.6	1%	99%
40	0.425	370.0	376.4	2%	97%
60	0.25	354.0	361.3	2%	94%
140	0.106	342.0	388.3	15%	80%
200	0.075	327.7	364.5	12%	68%
Pan		364.0	581.7	68%	

*Washed Material

% Passing = 100 - Σ% Retained

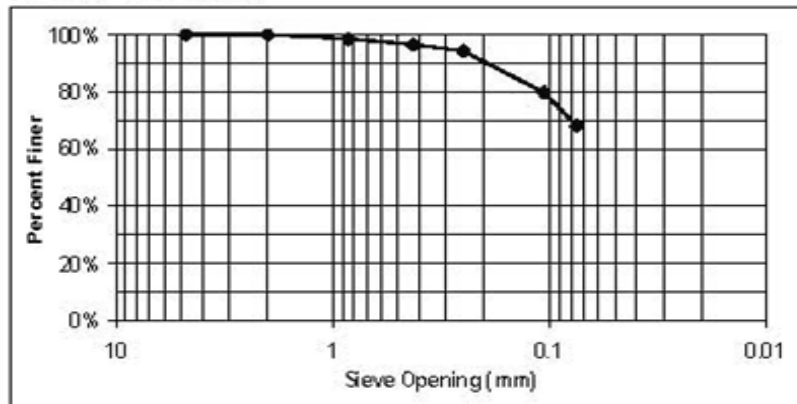

Detailed soils analysis



The University of New Mexico

UNIVERSITY OF NEW MEXICO
DEPARTMENT OF CIVIL ENGINEERING

GRAIN SIZE ANALYSIS

Urban Flood Demonstration Program

ECE (Diversion E)

Projec

Boing Identification

I. Pedro

Tested By

5
Pan No.

5
Soil Bag No.

1
Sieve No.

January 12, 2007

Date of Testing

Light Brown Sand

Field Description of Soil

682.9

Mass of Dry Sample, M_s

24 - 31.5

Depth of Sample (m)

Sieve No.	Diameter (mm)	Mass of Sieve (g)	Mass retained (sieve + soil) (g)	% Retained	% Passing
4	4.75	503.2	503.2	0%	100%
10	2	464.4	478.9	2%	98%
20	0.85	413.1	436.2	3%	94%
40	0.425	370.0	383.8	2%	92%
60	0.25	354.0	388.0	5%	87%
140	0.106	342.0	737.9	58%	30%
200	0.075	327.7	428.1	15%	15%
Pan		364.0	465.7	15%	

% Passing = 100 - Σ% Retained

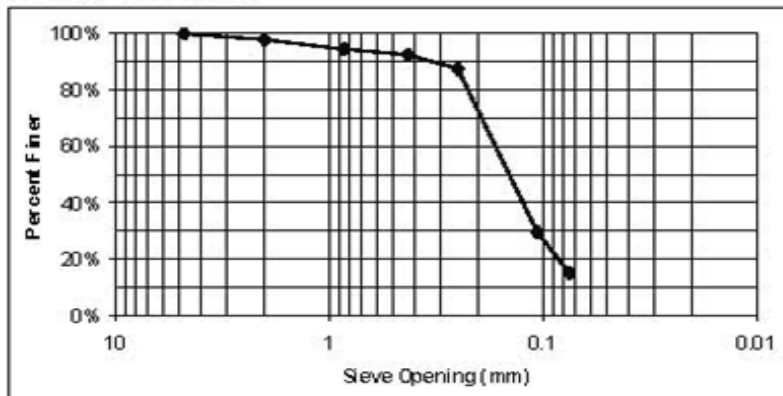

Detailed soils analysis



The University of New Mexico

UNIVERSITY OF NEW MEXICO
DEPARTMENT OF CIVIL ENGINEERING

GRAIN SIZE ANALYSIS

Urban Flood Demonstration Program

Projec

ECE (Diversion E)

Boing Identification

J. Pedro

Tested By

6
Pan No.

9
Soil Bag No.

2
Sieve No.

January 12, 2007

Date of Testing

Light Brown Sand

Field Description of Soil

770.0

Mass of Dry Sample, M_s

51.5 - 60

Depth of Sample (in)

Sieve No.	Diameter (mm)	Mass of Sieve (g)	Mass retained (sieve + soil) (g)	% Retained	% Passing
4	4.75	515.7	515.7	0%	100%
10	2	490.7	492.5	0%	100%
20	0.85	412.6	416.6	1%	99%
40	0.425	381.9	387.7	1%	98%
60	0.25	366.8	426.8	8%	91%
140	0.106	342.5	887.9	71%	20%
200	0.075	338.7	416.8	10%	10%
Pan		364.0	438.2	10%	

% Passing = 100 - Σ% Retained

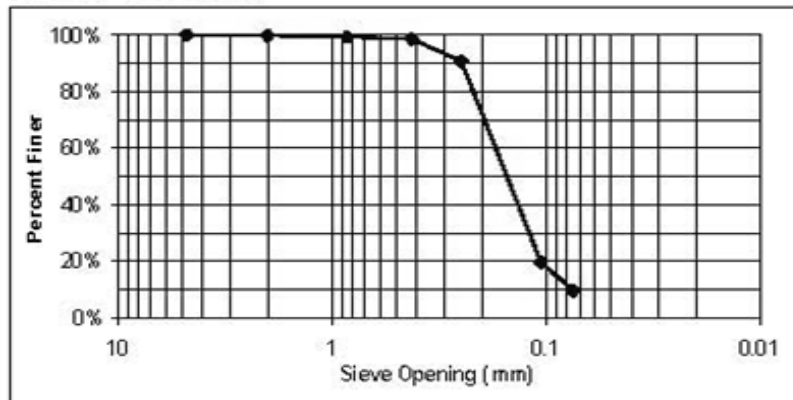

Detailed soils analysis



UNIVERSITY OF NEW MEXICO
DEPARTMENT OF CIVIL ENGINEERING

GRAIN SIZE ANALYSIS

The University of New Mexico

Urban Flood Demonstration Program
Project

ECE (Diversion E)
Boiling Identification

I. Pedro
Tested By

7 11 1
Pan No. Soil Bag No. Sieve No.

January 12, 2007
Date of Testing

Light Brown Sand
Field Description of Soil

746.8
Mass of Dry Sample, M_s

67 - 73
Depth of Sample (m)

Sieve No.	Diameter (mm)	Mass of Sieve (g)	Mass retained (sieve + soil) (g)	% Retained	% Passing
4	4.75	503.2	503.2	0%	100%
10	2	464.4	465.8	0%	100%
20	0.85	413.1	420.3	1%	99%
40	0.425	370.0	388.5	2%	96%
60	0.25	354.0	467.5	15%	81%
140	0.106	342.0	851.3	68%	13%
200	0.075	327.7	381.7	7%	6%
Pan		364.0	407.1	6%	

% Passing = 100 - Σ% Retained

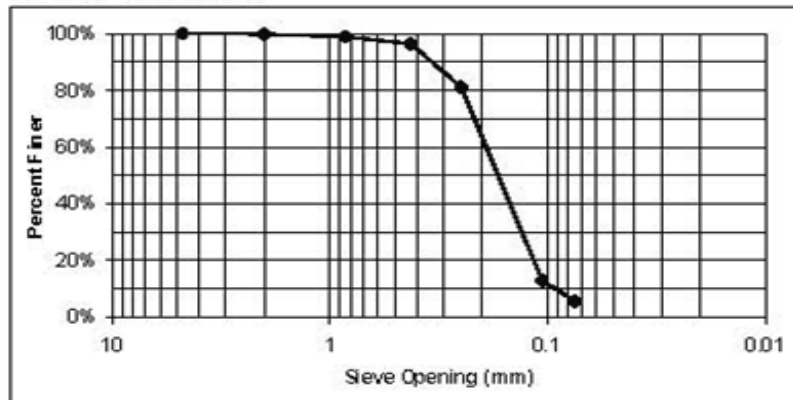

Detailed soils analysis



UNIVERSITY OF NEW MEXICO
DEPARTMENT OF CIVIL ENGINEERING

GRAIN SIZE ANALYSIS

The University of New Mexico

Urban Flood Demonstration Program

ECE (Diversion E)

Project

Boiling Identification

I. Pedro

8 12 2

Tested By

Pan No. Soil Bag No. Sieve No.

January 12, 2007

Brown Sand

Date of Testing

Field Description of Soil

886.3

73 - 80

Mass of Dry Sample, M_s

Depth of Sample (in)

Sieve No.	Diameter (mm)	Mass of Sieve (g)	Mass retained (sieve + soil) (g)	% Retained	% Passing
4	4.75	515.7	515.9	0%	100%
10	2	490.7	497.3	1%	99%
20	0.85	412.6	425.6	1%	98%
40	0.425	381.9	411.7	3%	94%
60	0.25	366.8	652.6	32%	62%
140	0.106	342.5	817.4	54%	9%
200	0.075	338.7	383.9	5%	3%
Pan		364.0	393.9	3%	

% Passing = 100 - Σ% Retained

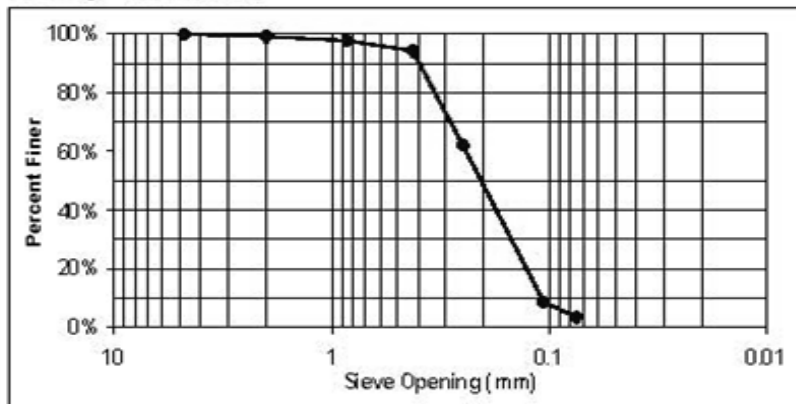

Detailed soils analysis



UNIVERSITY OF NEW MEXICO
DEPARTMENT OF CIVIL ENGINEERING

GRAIN SIZE ANALYSIS

The University of New Mexico

Urban Flood Demonstration Program

Projec

I. Pedro

Tested By

January 12, 2007

Date of Testing

749.6

Mass of Dry Sample, M_s

ECE (Diversion E)

Boring Identification

9

Pan No.

16

Soil Bag No.

1

Sieve No.

Brown Sand

Field Description of Soil

100 - 106

Depth of Sample (m)

Sieve No.	Diameter (mm)	Mass of Sieve (g)	Mass retained (sieve + soil) (g)	% Retained	% Passing
4	4.75	503.2	522.7	3%	97%
10	2	464.4	471.8	1%	96%
20	0.85	413.1	432.7	3%	94%
40	0.425	370.0	460.8	12%	82%
60	0.25	354.0	666.9	42%	40%
140	0.106	342.0	610.7	36%	4%
200	0.075	327.7	344.7	2%	2%
Pan		364.0	376.7	2%	

% Passing = 100 - Σ% Retained

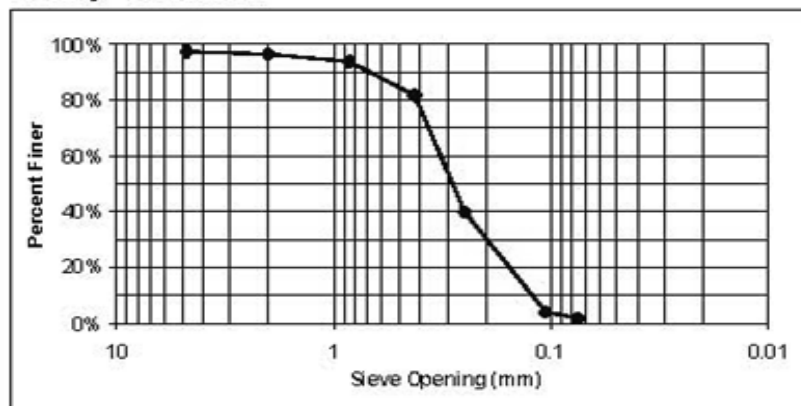

Detailed soils analysis

 UNIVERSITY OF NEW MEXICO
 DEPARTMENT OF CIVIL ENGINEERING

HYDROMETER ANALYSIS

The University of New Mexico

Project		Issued By		Date
Urban Flood Demonstration Project		J. Pedra		3-Apr-2007
Soiling Identification	Cylinder #	Depth (ft)	Time	Sample Wt. (g)
ECE	2	0-7	12:15 PM	50.0
Specific Gravity	Moisture Content (%)		Notes	
2.70	19.7		Soil Bag 1, Pan 3	

MENISCUS CORRECTION (m)	<u>4</u>
G _s CORRECTION FACTOR (α)	<u>0.99</u>
SUSPENSION CONSTANT (k)	<u>0.01328</u>
CORRECTED SAMPLE WT. (W _s)	<u>40.2</u>
PERCENT PASSING #200 SIEVE	<u>79%</u>

Elapsed Time (min)	Hydrometer Reading		Temperature (°C)	Effective Depth (cm)		Particle Diameter (mm)	% Finer (%)
	Orig.	R _s		R _{a(Corr)}	Corrected		
2	20	16	22	13.7	13.5630	0.0346	31.2%
5	16	12	21	14.3	14.1570	0.0223	23.4%
10	14	10	21	14.7	14.5530	0.0160	19.5%
15	11	7	21	15.2	15.0480	0.0133	13.6%
20	11	7	21	15.2	15.0480	0.0115	13.6%
30	10	6	21	15.3	15.1470	0.0094	11.7%
60	10	6	21	15.3	15.1470	0.0067	11.7%
250	10	6	21	15.3	15.1470	0.0033	11.7%
1440	9	5	19	15.5	15.3450	0.0014	9.7%

Detailed soils analysis



The University of New Mexico

UNIVERSITY OF NEW MEXICO
DEPARTMENT OF CIVIL ENGINEERING

HYDROMETER ANALYSIS

Project Urban Flood Demonstration Project		Designed By I. Pedro		Date 3-Apr-2007
Soil Identification ECE	Cylinder # 3	Depth (ft.) 13 - 17	Time 12:20 PM	Sample Weight 50.0
Specific Gravity 2.70	Mixture Unit (g/cc) 16.7	Notes Soil Bag 3, Pan 4		

MENISCUS CORRECTION (m)	<u>4</u>
G _s CORRECTION FACTOR (α)	<u>0.99</u>
SUSPENSION CONSTANT (K)	<u>0.01328</u>
CORRECTED SAMPLE WT. (W _s)	<u>41.7</u>
PERCENT PASSING #200 SIEVE	<u>68%</u>

Elapsed Time (min)	Hydrometer Reading		Temperature (°C)	Effective Depth (cm)		Particle Diameter (mm)	% Finer (%)
	Orig.	R _s		R _{s(Corr)}	Corrected		
2	30	26	21	12.0	11.8800	0.0324	42.0%
5	22	18	21	13.3	13.1670	0.0216	29.1%
10	19	15	21	13.8	13.6620	0.0155	24.2%
15	18	14	21	14.0	13.8600	0.0128	22.6%
20	16	12	21	14.3	14.1570	0.0112	19.4%
30	15	11	21	14.5	14.3550	0.0092	17.8%
60	13	9	21	14.8	14.6520	0.0066	14.5%
250	11	7	21	15.2	15.0480	0.0033	11.3%
1440	10	6	19	15.3	15.1470	0.0014	9.7%

Detailed soils analysis



The University of New Mexico

UNIVERSITY OF NEW MEXICO
DEPARTMENT OF CIVIL

GRAIN SIZE ANALYSIS

Urban Flood Demonstration Project
Project
I. Pedro
Tested By

ECE (Diversion E)
Boring Identification
3 1
Pan No. Soil Bag

Sieve No.	Diameter (mm)	% Passing
4	4.75	100%
10	2	100%
20	0.85	97%
40	0.425	94%
60	0.25	90%
140	0.106	84%
200	0.075	79%
	0.0346	31.2%
	0.0223	23.4%
	0.0160	19.5%
	0.0133	13.6%
	0.0115	13.6%
	0.0094	11.7%
	0.0067	11.7%
	0.0033	11.7%
	0.0014	9.7%

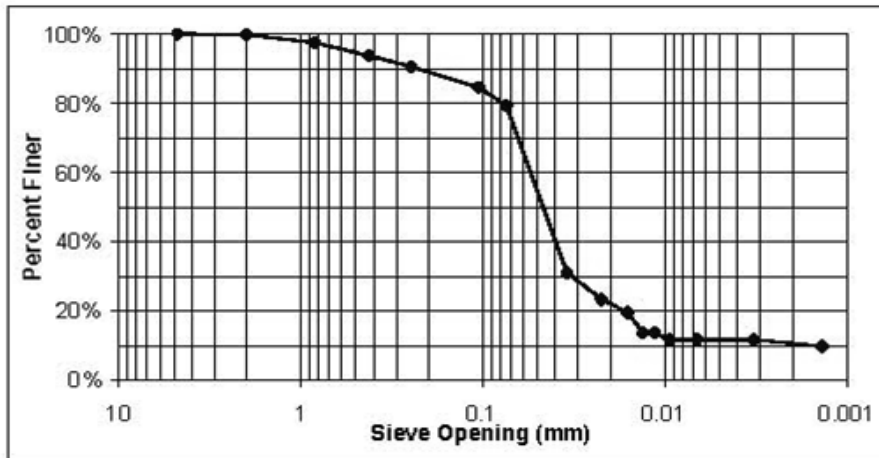

Detailed soils analysis



UNIVERSITY OF NEW MEXICO
DEPARTMENT OF CIVIL ENGINEERING

GRAIN SIZE ANALYSIS

The University of New Mexico

Urban Flood Demonstration Project
Project
I. Pedro
Tested By

ECE (Diversion E)
Boring Identification
4 3
Pan No. Soil Bag

Sieve No.	Diameter (mm)	% Passing
4	4.75	100%
10	2	100%
20	0.85	99%
40	0.425	97%
60	0.25	94%
140	0.106	80%
200	0.075	68%
	0.0324	42.0%
	0.0216	29.1%
	0.0155	24.2%
	0.0128	22.6%
	0.0112	19.4%
	0.0092	17.8%
	0.0066	14.5%
	0.0033	11.3%
	0.0014	9.7%

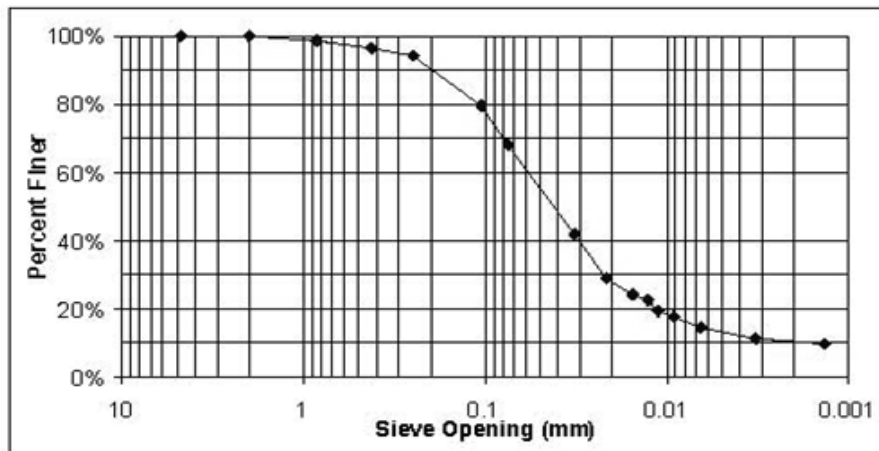

Detailed soils analysis



The University of New Mexico

UNIVERSITY OF NEW MEXICO
DEPARTMENT OF CIVIL ENGINEERING

SOIL WASHING ANALYSIS

January 12 & 13*, 2007
Date of Washing
January 13 & 16*, 1007
Date of Weighing
EC (Diversion)
Boring Area

J. Pedro
Name

FROM WATER CONTENT ANALYSIS

Boring Identification	ECE		ECW	ECN*
Pan	3	4	10	1
Boring Bag	1	3	1	1
Mass of Dry Soil (g)	455.4	317.8	344.4	432.3
Bowl	C	D	E	A
WASHED AND DRIED				
Pan	3	4	10	1
Mass of Pan + Dry Soil (g)	329.0	292.1	358.8	381.9
Mass of Pan (g)	139.1	139.2	139.4	139.2
Mass of Dry Soil (g)	189.9	152.9	219.4	242.7
Mass of Fines (g)	265.5	164.9	125.0	189.6

Detailed soils analysis

Appendix H: Groundwater Monitoring

Table of Contents

H-1 – H-6.....	Bosque PVC Groundwater Monitoring Wells
H-7.....	Completion Diagram of Typical BEMP Shallow Groundwater Well
H-8.....	Solinst Levellogger Comparison (Gold vs. Silver transducers)
H-9.....	Installation Schedule of Pressure Transducers and Barometric Pressure Loggers
H-10 – H-13...	Solinst Levellogger Installation and Maintenance
H-14	Surveyed Groundwater Well Elevations and Distances to River Bank From Wells
H-15	DWD Trial Operation and Activity Schedule: November 2006 – March 2007
H-16	Location Map: USGS River Gauge #08329918 Rio Grande at Alameda Bridge
H-17	USGS Gauge #08329918 Rio Grande at Alameda Bridge: 9/22/2006- 3/31/2007 (Graph)
H-18 – H-19...	Rating Table: USGS River Gauge #08329918 Rio Grande at Alameda Bridge (Graphs)
H-20	Bobcat (WU22) Well Cluster Water Table and River Gauge Height: 9/22/2006- 3/31/2007
H-21	Bobcat (WU22) South Well Water Table and River Gauge Height: 9/22/2006- 3/31/2007
H-22	Bobcat (WU22) West Well Water Table and River Gauge Height: 9/22/2006- 3/31/2007
H-23	Bobcat (WU22) East Well Water Table and River Gauge Height: 9/22/2006- 3/31/2007
H-24	Bobcat (WU22) Center Well Water Table and River Gauge Height: 9/22/2006- 3/31/2007
H-25	Badger (EU21) Well Cluster Water Table and River Gauge Height: 9/22/2006- 3/31/2007
H-26	Badger (EU21) South Well Water Table and River Gauge Height: 9/22/2006- 3/31/2007
H-27	Badger (EU21) West Well Water Table and River Gauge Height: 9/22/2006- 3/31/2007
H-28	Badger (EU21) East Well Water Table and River Gauge Height: 9/22/2006- 3/31/2007
H-29	Badger (EU21) Center Well Water Table and River Gauge Height: 9/22/2006- 3/31/2007
H-30	Location Map: USGS River Gauge #08329928 Rio Grande at Paseo Bridge
H-31	USGS Gauge #08329928 Rio Grande at Paseo Bridge: 9/22/2006- 3/31/2007 (Graph)
H-32 – H-33...	Rating Table: USGS River Gauge #08329928 Rio Grande at Paseo Bridge (Graphs)
H-34	Minnow (WD12) Well Cluster Water Table and River Gauge Height: 9/22/2006-3/31/2007
H-35	Minnow (WD12) North Well Water Table and River Gauge Height: 9/22/2006 3/31/2007
H-36	Minnow (WD12) West Well Water Table and River Gauge Height: 9/22/2006 3/31/2007
H-37	Minnow (WD12) East Well Water Table and River Gauge Height: 9/22/2006- 3/31/2007

H-38 Minnow (WD12) Center Well Water Table and River Gauge Height: 9/22/2006-
..... 3/31/2007
H-39 Diversion (ED10) Well Cluster Water Table and River Gauge Height:
..... 9/22/2006-3/31/2007
H-40 Diversion (ED 10) North Well Water Table and River Gauge Height:
..... 9/22/2006-3/31/2007
H-41 Diversion (ED 10) West Well Water Table and River Gauge Height: 9/22/2006-
..... 3/31/2007
H-42 Diversion (ED 10) East Well Water Table and River Gauge Height: 9/22/2006-
..... 3/31/2007
H-43 Diversion (ED 10) Center Well Water Table and River Gauge Height:
..... 9/22/2006-3/31/2007

BOSQUE PVC GROUND WATER MONITORING WELLS

JRT March 03 (rev)

1. Introduction

Shallow ground water (GW) wells are used in the Bosque to monitor water table (WT) elevations and to provide representative water chemistry samples from the saturated zone. Networks of wells can be used to determine shallow subsurface flow paths and spatial and temporal biogeochemical characteristics of the GW.

The wells are composed of 2-inch internal diameter PVC pipe with a solid upper casing and an intake that intersects the WT. The intake is the screened segment of the well through which GW flows. In the shallow, mostly unconfined aquifers typical of the Bosque research sites, the water level in the well is a good indicator of the depth to the water table (DWT).

Piezometers differ from monitoring wells in that they are constructed with a very short intake and are designed to measure hydraulic head from pressure head and elevation head. The water level in a piezometer generally does not give the direct position of the WT. Nested piezometers set at various depths are used to measure GW gradients and to construct flow nets. However, they are less suited for biogeochemical sampling than monitoring wells because the short intake restricts yield and represents a limited region of the saturated zone.

If possible, the well intake should be of sufficient length to encompass the range of expected WT elevations (Fig. 1). This may not be possible during flooding and high flows or during very dry periods with low flows. The optimal time to install wells is during base flow when low WT elevations facilitate hole boring in the Bosque. Base flow conditions depend of course on

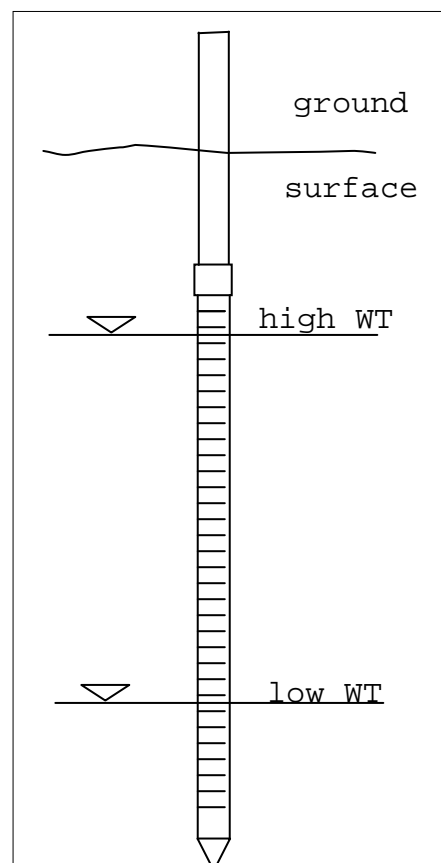

Figure H-1. Intake screen should capture range in WT elevations if possible.

weather conditions, and vary in time and space along the Middle Rio Grande. We have observed low flows during:

1. April, when irrigation begins but prior to peak snowmelt runoff.
2. Late June, post snowmelt peak and prior to summer monsoon season.
3. Late September/early October, post monsoon season but before the end of irrigation season.

2. Supplies, tools and equipment

A. Supplies (available at Rodgers & Co., Inc., Isleta SE, ABQ--UNM POs accepted)

- PVC pipe--2" ID Sch 40, screened (0.01" or 10-slot, \$30.30/10') for intake and solid (\$5.60/10') for casing. Amount depends on DWT, flooding vs. non-flooding site, etc. Pipes come in various lengths, are sold by the foot, and come with male and female threaded ends. Solid pipe ends are also sold unthreaded, some with built-in coupling. Unthreaded solid pipes w/coupled joints are less likely to break during well insertion.
- 2" PVC drive points, male and female threaded (\$7.50 ea) depending on your screened pipe ends. Slip-type points that are inserted into non-threaded screen pipe are also handy for cut lengths of screened PVC, but may not be available at Rodgers. 1/well.
- 2" slip couplers to join pipes as needed--depends on # of solid PVC ends w/built-in coupling, but slip couplers are handy for extending well lengths, etc. (\$1.35 ea).
- 2" PVC well caps--slip type (\$1.02 ea). 1/well. Locking types available, \$15-20 each.
- PVC primer and cement for some joint connections, e.g. slip points w/cut screen pipe.
- Bentonite--to seal annular space near surface, sold in 50# bags (\$6.03) as Hole- or Kwik-Plug. Go w/3/8" chips vs. pellets (costly) or powder. Enough for several wells.
- Silica sand--size 10-20 (\$6.23/50# bag), for the well filter pack. Plan on ~ 1 bag/well.

B. Tools/Equipment

- Soil auger w/3" bucket and extensions, 2 adj. wrenches and strap wrench

- San Angelo rod w/spade end for breaking up roots, hard soils
 - Steel rods for packing sand--1-2, 1 long enough to reach near depth of well if possible
 - Fence post driver that fits over PVC pipe
 - Sledgehammers--1 large (10-12-lb. head), one small (for packing rods, etc.)
 - Sledgehammer blocks--~15" L 4"x4" blocks w/partially bored hole that fits over the 2" PVC pipe. Note--fence post driver preferred over sledgehammer driving, see p. 4.
 - Stepladder—to stand on if necessary when starting the well driving
 - Pipecutter--for ≥ 2 " pipe
 - 10 m graduated $\frac{1}{2}$ " PVC pole for measuring depths in bore hole
 - Water level indicator (beeper)
 - Tape measure (w/metric highly preferable)
 - Well bailer
 - Duct tape, hacksaw, large screwdriver, WD-40, pipe wrench, shovel
 - Spray paint--cans of gray and brown spray paint to camouflage wells as needed
 - Compass (or GPS unit), 100 m tape, flagging, loppers, and bow saw for siting wells
 - Sediment sampling materials--Whirli-bags, dumping bin, trowel
 - 5 gal bucket--for supplies and to stand on if necessary, e.g. starting the well driving
- C. Misc--head protection (hard hats/goggles, if using sledgehammer method), work gloves, site keys & permits, fieldbook, pencil, calculator, black sharpie, drinking water, bug spray**

3. Well Installation

A. Bore Hole

- Auger down to WT, collecting sediment samples for texture analysis if desired. The seds should be sloppy-wet at the WT. If just damp you may have only reached the capillary fringe--keep digging.
- At the WT the hole will collapse and boring deeper will be limited. Use the auger/rod to try to work (loosen) the seds at the WT and advance the hole as best you can (Fig. 2). This will facilitate driving in the well. Estimate DWT using the PVC rod or beeper.

B. Assemble the Well

- Determine the intake length based on the DWT. Try to extend the well ~ 100 cm below the WT (more if WT is not near base flow). The intake should end up ~ 25 cm below ground. So, cut the screened PVC to the DWT plus 75 cm (Fig. 3) It's best to use the pipecutter to ensure that connections are tight.
- Attach a drive point and a length of solid PVC for the casing to the intake screen. Use male/female or slip-type points and slip couplings as necessary. Use PVC primer and cement if necessary. The solid PVC should be long enough to cover the 25 cm below ground depth and to fit the fence post driver (150 cm is a good length).
- Now that the well is assembled, measure the effective screen length (Fig. 4), correcting for sections covered by couplings, etc. For example, a slip-type drive point inserted into a cut piece of screened PVC pipe will eliminate ~ 3.3 cm of intake.
- Measure the well from the bottom, marking the casing at convenient intervals (e.g. 10 cm, Fig. 5). Also mark the casing at the point at which the well driving should stop, i.e., ~ 25 cm above the intake.

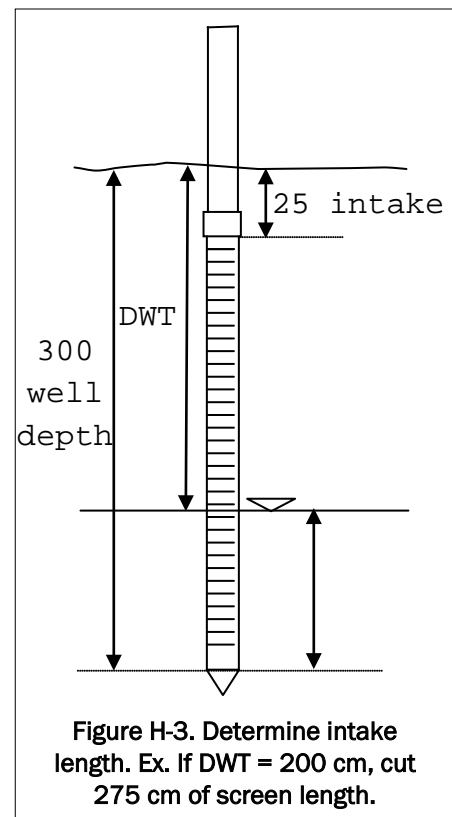
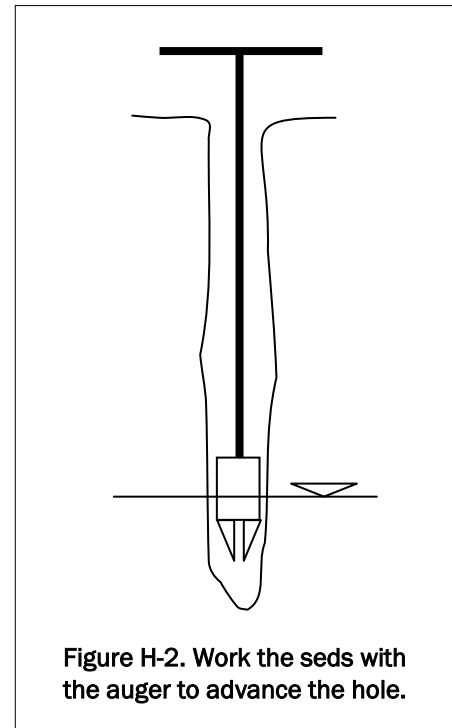
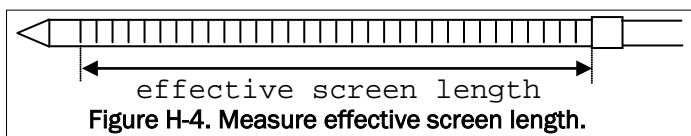

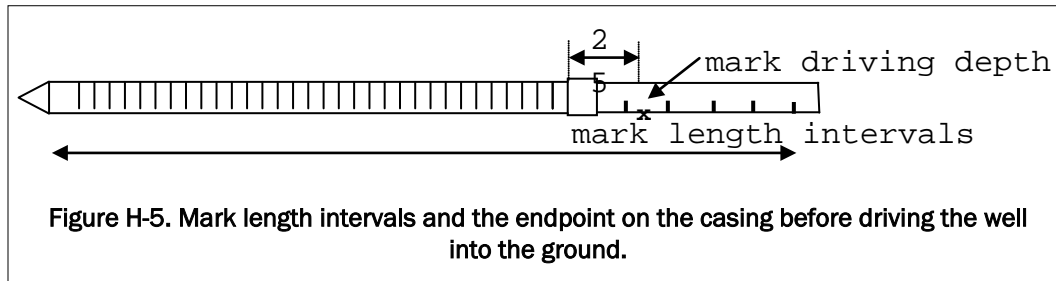

C. Insert the Well

- Drive the assembled well into the bored hole, working it in by hand as deep as possible.
- Cover the top of the well casing with a couple of strips of duct tape.
- Drive the well to the desired depth using the fence post driver. Less recommended is to place a wood block atop the casing and strike it with the sledgehammer (the block will need to be held in place by a crewmember--wear your hard hat, goggles and gloves). The sledgehammer can also be used to advance the fence post driver if it becomes too difficult to advance by hand--use a 2x4 scrap atop the post driver. With either method, don't use too much force or you risk shattering the well, particularly the intake. This is the main reason that it's best to install wells at base flow, since the hole can be bored deeper and pounding the well is minimized. Driving the well may require a stepladder to stand on.
- When the well is at the desired depth, record the depth to intake, e.g. 25 cm. If the well was driven to a point above or below the mark you made on the casing, compute the difference.

D. Pack the Well

- Temporarily cap the well.
- Fill the annular space around the well with the filter pack (silica sand). The filter pack enhances well yield and helps filter out fine materials that can accumulate in the well and clog the intake. Pour some sand, pack, and repeat as necessary (see next step).

- Tamp the sand with steel rods (Fig. 6) to eliminate gaps and make a tight packing. Wiggle the well to help move sand down the borehole. Fill and pack to just above the coupling between the intake and the casing. The well should be packed tight, difficult to spin by hand.

Next, fill and pack with some of the extracted Bosque sediments to within ~ 10 cm of the ground surface, then add a thin layer (~2-3 cm thick) of bentonite around the casing (Fig. 7). Pour a couple of bailers' worth of water onto the bentonite and allow to soak in. Fill the remainder of the hole with more of the

extracted sediments and pack tightly around the base of the well with a short blunt object, e.g. the end of a hammer or wrench. Don't use the long rod, which could trash your bentonite layer.

E. Well Specs

- Adjust the casing height to the desired length by cutting or extending with a coupler, e.g. ≤ 20 cm in non-flooding sites, above potential flood level in flooding sites. A pipecutter makes a more level cut than a hacksaw and eliminates PVC shavings.
- Cut 2 notches in the casing $\sim 1/2$ " apart with a hacksaw (Fig. 8). This area serves as the tape position when beeping the well.
- Label the well on the inside and outside of the casing.

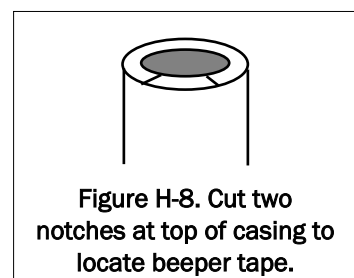
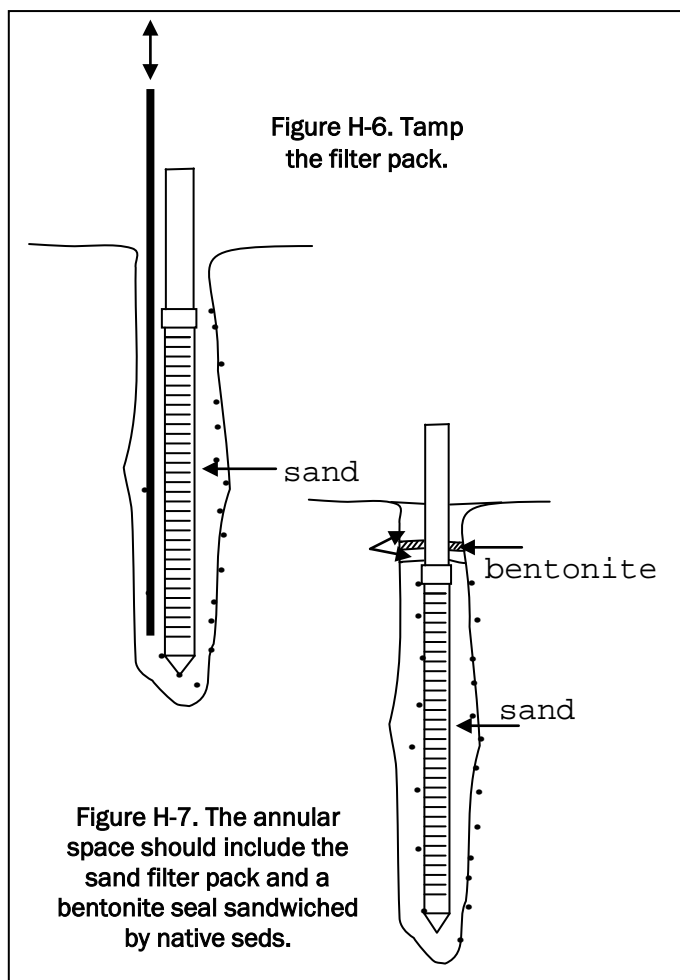

- Beep the well. Measure the casing height, the distance from the base of the well at the ground surface to the rim at the top of the casing between the 2 notches. Calculate and record the well specs in your field book (see next page). It is helpful to sketch the well and fill in some of these data, similar to Fig. 9, next page.

- Effective screen length (measured before you installed well):

- Intake depth (determined before you packed the well):

- Casing height (CH):

- Total well length (TWL, measure from marked intervals on casing):

- Well depth (TWL - CH): _____

- Beep: _____

- DWT (beep - CH): _____

- Depth below WT (TWL - beep): _____

- Other info that might be useful to

hydrogeology types:

— Auger/borehole diam.: 10 cm (4")

— Intake diam.: 5 cm (2")

— Casing diam.: 5 cm (2")

— Screen slot size: 0.25 mm (0.01")

— Filter pack: 10-20 mesh silica sand

— Surface seal: 3/8" bentonite chips

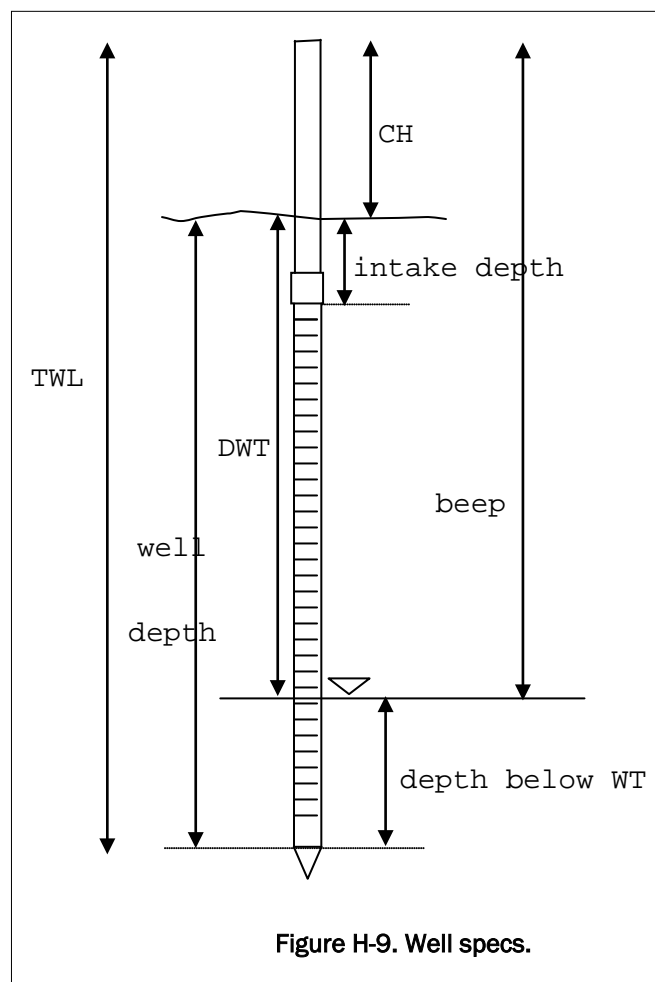

F. Work the Well

- Wells should be worked extensively after they are installed to clear fine materials and leach solvents if used (PVC cement).
- Elevate and drop the bailer several times to flush fines, etc. out of the well and filter pack annular space. Also bail the well several times. The well water should become noticeably clearer. Cap the well LOOSELY, or use a locking cap if available.
- Wells should be worked regularly, especially prior to GW sampling.
- Make the well inconspicuous if it is in area susceptible to vandalism. Dry off the well casing and apply a coating of gray spray paint, then a few splotches of brown spray paint, or use camo spray paints if available. Try to hide the well with branches, leaves, etc.

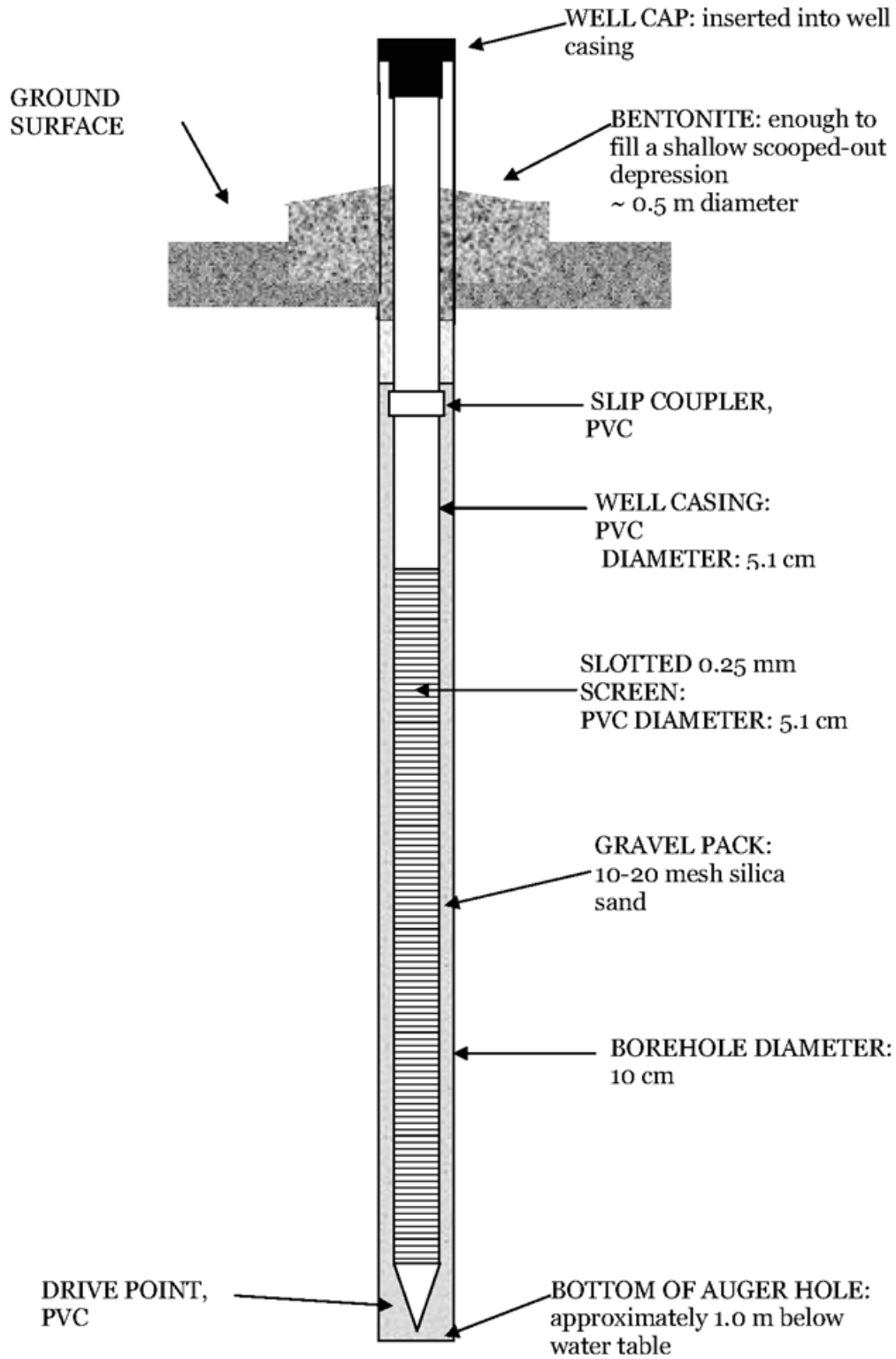

Completion diagram of typical BEMP shallow groundwater well.

Solinst**Levellogger Comparison**

Model 3001

	Levellogger Gold	Old Levellogger
Backward Compatible	YES	YES
Pressure Transducer	Piezoresistive Silicon in 316L Stainless Steel	Ceramic
Calibrated Ranges:	15, 30, 60, 100, 300 ft, Atmospheric Barologger 5, 10, 20, 30, 100m, Atmospheric Barologger	15, 30, 60, 100, 300 ft + 5 ft. Barologger 5, 10, 20, 30, 100m + 1.5 m Barologger
Accuracy (typical)	0.05% net FS \pm 0.010, 0.016, 0.032, 0.064, 0.328 ft (\pm 0.3, .5, 1, 1.5, & 5cm) Barologger: \pm 0.003 ft. (0.1 cm)	0.1% net FS \pm 0.02, 0.03, 0.06, 0.10, 0.33 ft (\pm 0.5, 1, 2, 3, 10 cm) Barologger \pm 0.02 ft (0.5 cm)
Accuracy (Max Error)	0.1% net FS - very stable readings Readings fluctuate within 0.01% FS	0.2% net FS Readings fluctuate up to 0.2% FS
Resolution	Baro: 0.002% FS, M5/F15: 0.001 % FS, Other Ranges: 0.0006 % FS	Baro: 0.1%, All Other Ranges: .02%
Calibration	Factory – Lifetime calibration	Factory – Lifetime calibration
Response Time (90% Thermal Δ)	< 1 minute	1 – 3 minutes
Temp Comp Range	-10 to +40°C	-10 to +40°C
Temperature Sensor	Platinum Resistance Temperature Detector	Spreading Resistance Silicon
Temperature Accuracy	\pm 0.05°C	\pm 0.1°C
Temperature Resolution	0.003°C	0.01°C
Operating Temp Range	-20 - +80°C	-20 - +80° C
Clock Accuracy	\pm 1 minute / year.	< 1 second / day (6 min / year)
Battery Life	10 Years	8 - 10 years
Size	7/8 x 6" (22 mm x 154 mm)	7/8 x 4.9"
Weight	6.3 oz (179 grams)	5.7 oz (160 grams)
Memory	40,000 Readings of Level and Temperature Superior Reliability EEPROM Memory with redundant backup of last 1200 logs	24,000 Readings of Level and Temperature
Logging Rates	0.5 sec – 99 hours	0.5 sec – 99 hours
Logging Modes	Linear, Event & User-Selectable Schedules with 30 items, each with Sec, Min, Hours, Days or Weeks duration	Linear, Event and choice of 3 pre-set Logarithmic style schedules
Barometric Compensation	High accuracy, air-only, Barologger	Barologger - water based
Altitude Input	Range = -980 to 16,400 ft. (-300 to 5,000 m)	Range = -980 to 9,800 ft. (-300 to 3,000 m)
Corrosion Resistant Coating	Zirconium Nitride (ZrN) PVD	None
Other Wetted Materials	Delrin, Viton, Stainless Steel	Stainless Steel, Ceramics, Akulon, Viton
Direct Read Capability	Yes	Yes
Handheld Data Transfer Leveloader	Yes - with Levellogger 2.0 software	Yes
Software Version 3	Many new features: see Data Sheet. Can be translated into other languages	
Offset	Allows input in range equal to Altitude Range = -980 to 16,400 ft. (-300 to 5,000 m)	Limited input based on transducer range

Printed in Canada
October 30, 2006

For further information contact: Solinst Canada Ltd.
 Fax: +1 (905) 873-1992; (800) 516-9081 Tel: +1 (905) 873-2255; (800) 661-2023
 35 Todd Road, Georgetown, Ontario, Canada L7G 4R8
 Web Site: www.solinst.com E-mail: instruments@solinst.com

Solinst

This chart compares the new Solinst Gold loggers with the older model Silver loggers. There are three Silver loggers installed in the center wells at Badger (EU21), Bobcat (WU22), and Diversion (ED10), while the remaining loggers are Golds (with the exception of the Sutron logger located in the Minnow (WD12) Center well.

Installation Schedule of Pressure Transducers and Barometric Pressure Loggers

<u>Well</u>	<u>Type/Model</u>	<u>Installation Date</u>
Minnow (WD12) Center	Sutron #56-113	8/27/2005
Diversion (ED10) Center	Solinst Silver 3001	11/23/2005
Badger (EU21) Center	Solinst Silver 3001	11/23/2005
Bobcat (WU22) Center	Solinst Silver 3001	11/23/2005
Rio Grande Nature Center West	Solinst Silver 3001 (Baro)	11/23/2005
Diversion (ED10) East	Solinst Gold 3001	8/31/2006
Bobcat (WU22) North	Solinst Gold 3001 (Baro)	8/31/2006
Diversion (ED10) North	Solinst Gold 3001	9/22/2006
Diversion (ED10) West	Solinst Gold 3001	9/22/2006
Minnow (WD12) North	Solinst Gold 3001	9/22/2006
Minnow (WD12) West	Solinst Gold 3001	9/22/2006
Minnow (WD12) East	Solinst Gold 3001	9/22/2006
Badger (EU21) South	Solinst Gold 3001	9/22/2006
Badger (EU21) West	Solinst Gold 3001	9/22/2006
Bobcat (WU22) West	Solinst Gold 3001	9/22/2006
Bobcat (WU22) East	Solinst Gold 3001	9/22/2006
Bobcat (WU22) South	Solinst Gold 3001	9/22/2006
Badger (EU21) East	Solinst Gold 3001	9/28/2006

SOLINST LEVELLOGGERS INSTALLATION & MAINTENANCE (for Enviro 2-inch locking well caps)

I. BEFORE HEADING OUT w/LOGGERS

- Go to well if possible, measure available cable length for the well, a.k.a. distance to resistance (DTR). Prep Levellogger (LGR) in lab--coil Direct Read Cable (DRC) to SCL based on DTR, etc., ahead of time. See section III.
- Preprogram LGRs as much as possible in Levellogger settings of Solinst software, e.g., site ID, units, sample mode, sample rate, altitude, etc. (see section IV).

II. FIELD EQUIPMENT/SUPPLIES

- Lap-top (PC, w/charged battery) w/Solinst software, Solinst PC interface cable, Solinst optical IR reader (if available, in case DRCs don't communicate w/LT), storage (jump drive, zip, CD, etc.)
- Solinst LGR(s) w/DRC(s) and Barologger (BAR) if applicable.
- Enviro 2" locking well cap w/key, and a ring from a key chain to suspend the LGR
- Water level beeper (submersible type if measuring DTR)
- Flooding site (i.e. tall well casings)- stepladder, step stool or 5-gal bucket to stand on and LT support (e.g. well casing clamp/platform)
- Bailer and root removal tool (10 ft length of 0.5 inch PVC w/hooks and rope)
- Cable ties 7-inch or smaller size for coiling excess cable
- Tape--electrical, duct
- Measuring tape (metric)
- Wire cutters, pipecutter for 2" PVC, and small utility saw w/spare blades
- Small tarp or large ziplock bags to lay sensors on (keep electrical connections clean)
- Field book (incl well specs)/pencil/Sharpie, calculator, site keys & permits if applicable
- Cell phone, water, sunblock, bug repellent

III. INSTALLING THE LEVELLOGGER

- Note: As mentioned above, it's best to measure DTR and CH ahead of time, then measure out and prep LGR in lab and return to install LGR.
- Work well: flush/bail several times. Extract roots if necessary.

- If not yet measured, measure DTR_{Bw} /beeper off, allow it to just contact the well bottom and read tape at beep mark. Suspend length (SL) should be ~ 10 cm less than DTR to ensure that sensor is suspended above well bottom.
 - Set cable to SL (again this can be done ahead of time in the lab, and likely with greater accuracy, by using a lab bench or floor and a tape measure or meter stick and by marking 1 m lengths):
1. Connect DRC sensor end to LGR. Lay on plastic don't drag on ground.
 2. Keeping the DRC free of slack, measure and mark SL from line near base of LGR (just above circulation hole) to desired length on the cable.
 3. Slip the key chain ring through the small suspension hole in the bottom of the locking well cap. Loop the DRC at the PC end through the key chain ring to set it in place, and secure w/cable ties and electrical tape.
 4. For the sensor-to-beeper calibrations, the SL ends up running from the line at the sensor base to the beep mark on well. Thus, to the top of locking well cap (not the suspension hole), which rests atop the well rim where the beep mark is located (lightly sawed onto cap rim; see diagram below).

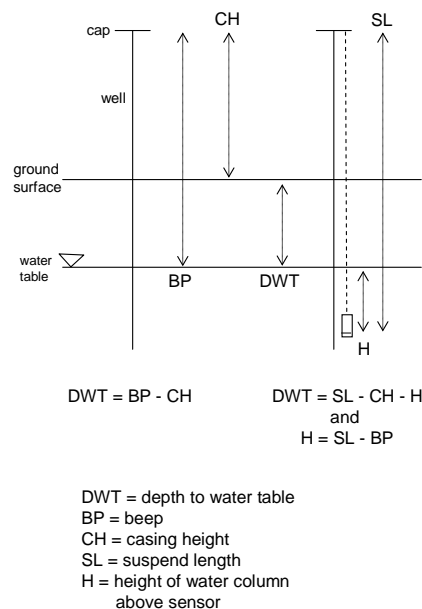

5. Shorten cable to the desired SL: Using your SL mark as a guide, make a simple figure of eight loop at a point ~ 10 - 15 cm below the mark, toward the sensor, and tighten the knot a bit. Re-measure SL from LGR mark to top well cap, and adjust loop as needed until the target SL is approached (remember to pull out slack when measuring, to simulate gravity). Secure

the loop/knot and excess cable w/cable ties and electrical tape. Measure and record final SL, which is likely a little off from your target SL.

- Beep and calculate h_{beep} (SL - beep).
- Make a mark on the well casing below the cap that can be used to line up the beep mark on the cap. This will ensure consistent measurements if the cap is removed or spun.
- Lower LGR into well.
- Install BAR if applicable (loop upper end around key ring, secure, etc.). Use a free well if available. If you must hang in a well that already has a LGR, hang from the key ring (use a sturdy ring if hanging a LGR and a BAR on one ring). BAR cables are short, but shorten further if necessary so the instrument hangs well above expected high water level. SL measurement is not necessary for BAR.
- If a BAR is not used and a tower or weather station is available, calculate effective barometric pressure (EBP):
 1. ___mb pressure x 0.01022 = ___m water column equivalent
 2. barometric offset = 1m/1000m elev = ___m/___m well elev
 3. elev corr offset: 9.5 m (sea level) - ___m (from baro offset above) = ___m
 4. effective baro pressure = water col equiv___m - elev corr offset___m = ___m
 5. actual water level above sensor is total (logged value) - EBP (convert to cm)

IV. PROGRAMMING THE LEVELLOGGER (2.0 software; version 1.5 is very similar)

- Get a BAR reading if possible—from existing BAR or new install (process is similar to LGR install that follows; not critical, but good to check whether LGR readings are OK at install).
- Connect PC to DRC via Solinst PC interface cable.
- In Solinst directory open up Levellogger.exe.
- In Levellogger Settings tab window click on Retrieve Settings From Levellogger.
- Edit as necessary: Project ID, location (well ID), sample mode, rate (fixed, 30 min), altitude (elev at top of well - SL), channel 1 (LEVEL, cm units, offset if desired), channel 2 (TEMP, EC). Enable Time Synchronization to System (PC) Time. The offset value in Channel 1 can be set, e.g for SL – casing ht, but it=s probably best to leave at zero since the raw data will eventually be compensated for barometric pressure and corrected for manual measurements during processing.

- Save the new logger settings by clicking on Program Settings to Levelogger.
- Start the LGR (“green light,” Start the Levelogger). It will ask about unsaved data. Any previous data should have been saved and backed up before this install. Now click on the Current Readings tab window and select Start the Real Time Data (display LEVEL if necessary) and note the value. It should approximate SL – beep – effective baro pressure (from BAR, probably around 55-75 cm). Back in the Levelogger Settings tab window, click on the “stop sign,” Stop the Levelogger.
- Enter a future start: Click “green light,” Start the Levelogger. Continue (allow data to be erased—there really shouldn’t be any). In the Start Levelogger window select “at” and enter the next half hour interval, at 00 seconds, e.g., 14:30:00. Make sure the date is right (should be, from when you synched to system time). Click OK.
- You’re good to go. Close the program, disconnect the PC from the DRC cap, replace cap cover and locking well cap, and lock the well.
- Spray camo the well head if necessary

V. BACK AT THE LAB

- Transcribe the field book data to a PC install info file (e.g Excel or database program).
- Back up the install file (portable hard drive, CD, DVD, zip, other PC, etc.)

VI. MAINTENANCE

- Supplies in addition to installation on p.1: squirt bottle w/water, spare water, mild detergent, 10% solutions of H₂SO₄ and acetic acid, old toothbrush, plastic beaker, rubber gloves, soft cloth, paper towels.
- Perform seasonally/annually.
- Collect PT data as normal.
- Remove LGR from well, inspect. Place on plastic sheet to keep dirt off sensor, DRC.
- Remove deposition from and clean stainless steel casing and DRC. Rinse with squirt bottle and use old toothbrush. If necessary, carefully remove hard water deposits with the acetic acid and/or bacterial/algal fouling with the H₂SO₄ (wear rubber gloves and use brush and plastic beaker).
- Clear out circulation hole near sensor bottom w/spray from squirt bottle. Do not insert objects through the circulation hole.

- If necessary to disconnect LGR from DRC (e.g., communication problems), clean optical IR eyes on sensor and cable head with a soft cloth and be sure all interior areas that will be sealed off are thoroughly dry before reconnecting the DRC to the LGR.
- DTR should be measured as part of annual maintenance to track debris accumulation in the wells (sediments, roots). If necessary, alter the SL accordingly, i.e., shorten a bit so it is suspended above the DTR.
- Thoroughly work (flush) the well w/the bailer.
- Replace the LGR to the well.
- Check LGR operation w/PC. Check current value (start LGR temporarily). Program a future start at the next half-hour.
- Disconnect PC, close up well.

Surveyed Groundwater Well Elevations

Distance to River Bank
(from respective well)

Site/Well

Site/Well	Well elevation TOC (m)	CH (m)	Well elevation GS (m)	To Bank	Distance to Bank (m)	Bank Elevation (m)
Diversion (ED10)				East	120.09	1522.79
East Well	1523.61	0.51	1523.10	Center	61.26	1522.83
Center Well	1523.27	0.55	1522.72	West	20.73	1522.83
West Well	1523.83	0.76	1523.07	North	61.87	1523.17
North Well	1523.39	0.68	1522.71			
Badger (EU21)				South	63.09	1523.16
South Well	1523.68	0.32	1523.36	East	71.32	1523.08
East Well	1523.49	0.12	1523.37	Center	38.71	1523.02
Center Well	1523.96	0.31	1523.65	West	8.53	1523.08
West Well	1524.09	0.28	1523.81			
Minnow (WD12)				East	5.79	1522.56
East Well	1523.55	0.53	1523.02	Center	35.97	1522.30
Center Well	1523.46	0.46	1523.00	West	74.68	1522.30
West Well	1523.67	0.48	1523.19	North	27.43	1522.47
North Well	1523.74	0.71	1523.03			
Bobcat (WVU22)				South	52.43	1523.66
South Well	1523.45	0.22	1523.23	East	11.28	1523.45
East Well	1523.92	0.35	1523.57	Center	50.29	1523.39
Center Well	1523.90	0.48	1523.42	West	89.92	1523.50
West Well	1524.04	0.35	1523.69	North	42.06	1523.74
North Well	1524.07	0.40	1523.67			

TOC=top of well casing, CH=well casing height above ground surface (GS)

DWD Trial Operation and Activity Schedule: 11/2006-3/2007

[November-06]	Channel Sand Bar Dredging and Relocation
[25-Jan-07 to 28-Jan-07]	Diversion Gate Trial Operation
[31-Jan-07]	Diversion Gate Trial Operation
[01-Feb-07]	West Bank Erosion
[02-Feb-07]	West Side Channel Sand Bar Relocation
[04-Feb-07]	West Side Channel Sand Bar Relocation
[07-Feb-07]	West Side Channel Sand Bar Relocation
[08-Feb-07]	Fish Passage Sediment Flush
[09-Feb-07]	Middle Channel Sand Bar Relocation
[09-Feb-07]	Field Note and Water Depth taken from kayak
[11-Feb-07]	Middle Channel Sand Bar Relocation
[11-Feb-07]	Diversion Structure Maintenance
[12-Feb-07]	Middle Channel Sand Bar Relocation
[12-Feb-07 to 15-Feb-07]	Middle Channel Sand Bar Relocation
[15-Feb-07]	Middle Channel Sand Bar Relocation
[15-Feb-07]	Diversion Gate Trial Operation
[16-Feb-07]	Diversion Gate Trial Operation
[19-Feb-07]	Diversion Gate Trial Operation
[21-Feb-07]	Middle Channel Sand Bar Relocation
[24-Feb-07]	Middle Channel Sand Bar Relocation
[28-Feb-07]	Middle Channel Sand Bar Relocation
[02-Mar-07]	Diversion Gate Trial Operation
[06-Mar-07 to 07-Mar-07]	Piano-Like Diversion Gate Configuration
[09-Mar-07]	Piano-Like Diversion Gate Configuration
[13-Mar to 14-Mar]	Partially Raised Gate for Low-Flow Management
[15-Mar-07]	Sand Bars flushing over West Side Gates
[20-Mar-07]	Sand Bars flushing over West Side Gates
[22-Mar-07]	Partially Raised Gate for Low-Flow Management
[26-Mar-07]	Sediment Deposition on North Intake Bay
[27-Mar-07]	Center Gates Opening for Sand Bar Relocation
[30-Mar-07]	Center Gates Opening for Sand Bar Relocation

*Revised from Civil Engineering Graduate Student, Jungseok Ho.

Website: http://www.unm.edu/~abqdam/Periodical_Observation.htm

Date Range covers through end of study period, March 2007

Location Map: USGS River Gauge #08329918 Rio Grande at Alameda Bridge

Bernalillo County, New Mexico
Hydrologic Unit Code 13020203
Latitude 35°11'49", Longitude 106°38'27" NAD83
Gage datum 5,050 feet above sea level NGVD29
Date of Record Start: July, 2003

Location of the site in New Mexico.

Site map.

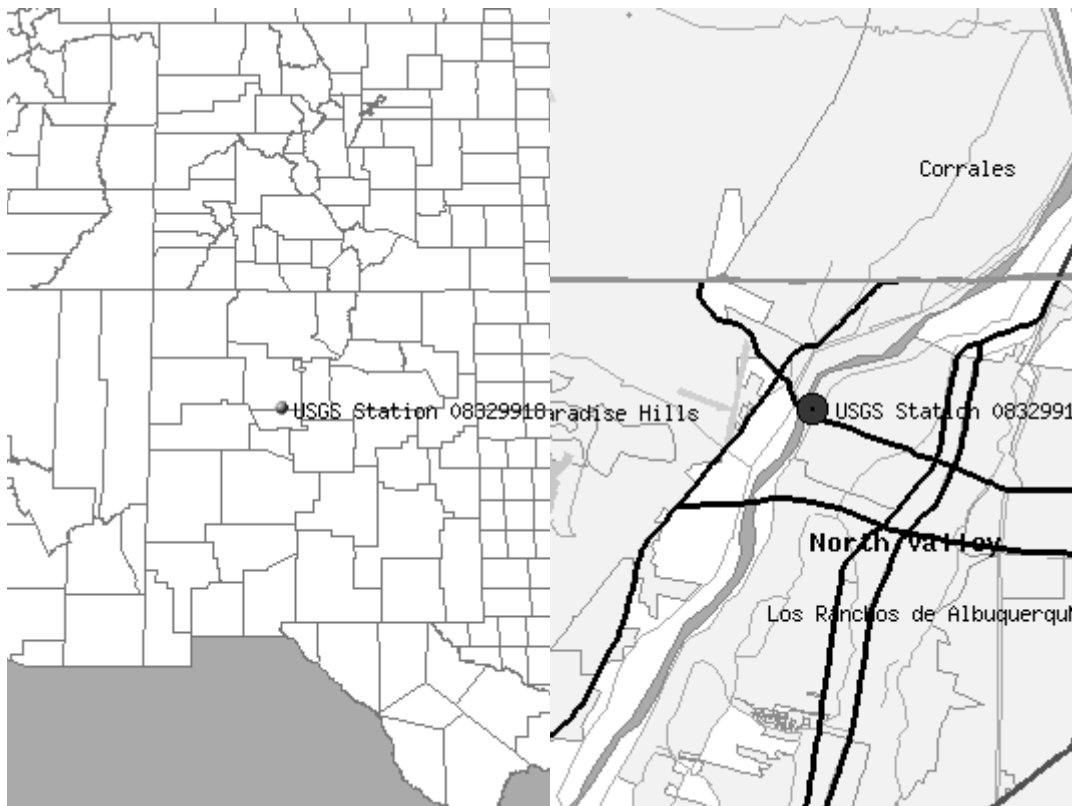

Maps are generated by [US Census Bureau TIGER Mapping Service](#).

*Revised from USGS National Water Information System New Mexico Web Interface http://waterdata.usgs.gov/nm/nwis/nwismap/?site_no=08329918

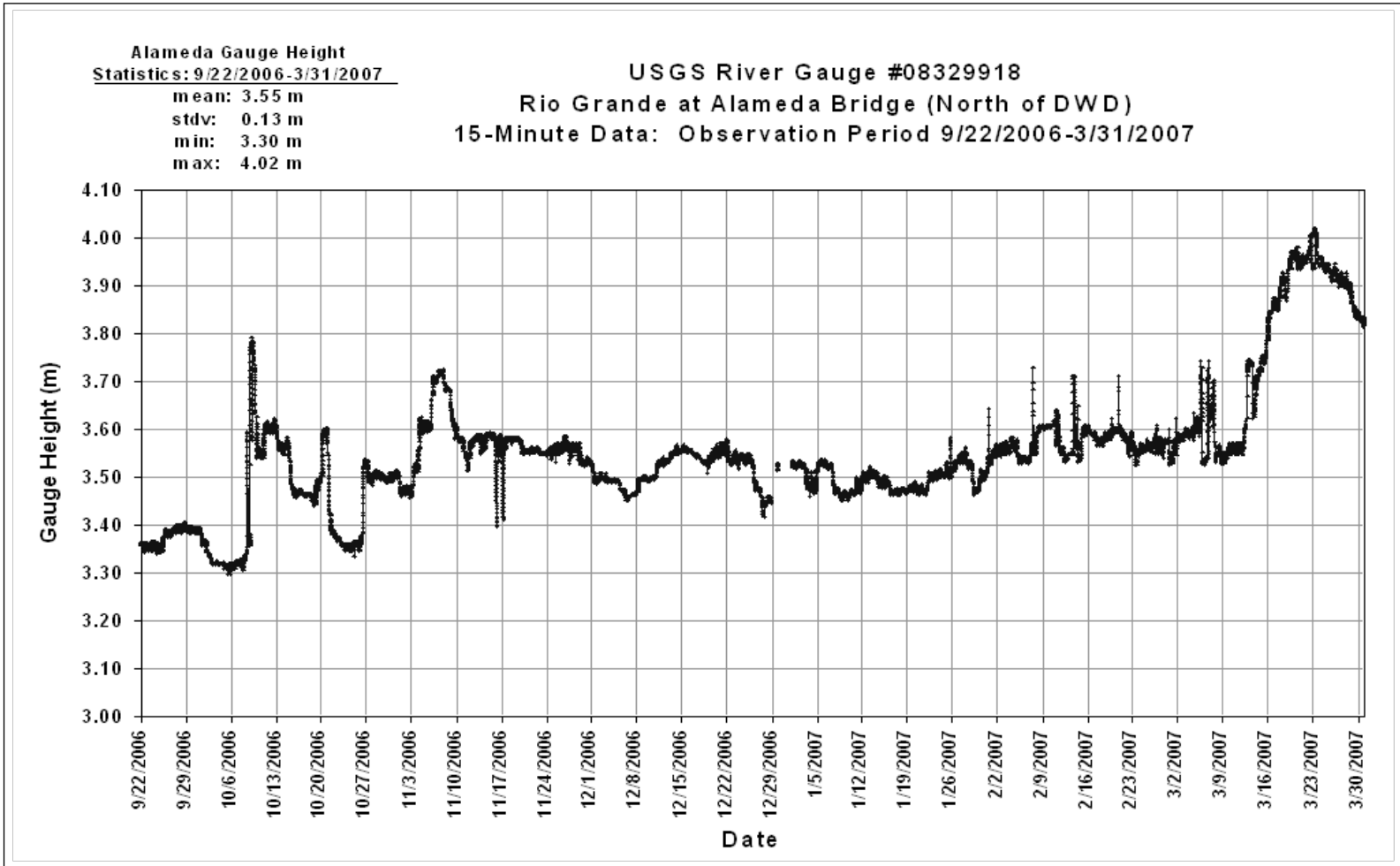

*The sudden spikes in the graph during the months of February and March of 2007 are a result of DWD trial operations. (Refer to Appendix 15-H: DWD Trial Operations and Activity Schedule).

USGS# 08329918 RIO GRANDE AT ALAMEDA BRIDGE, NM (Alameda Bridge Gauge)

Rating Table

p.1

U.S. DEPARTMENT OF THE INTERIOR - U.S. GEOLOGICAL SURVEY - WATER RESOURCES

STATION NUMBER 08329918 RIO GRANDE AT ALAMEDA BRIDGE AT ALAMEDA, NM SOURCE AGENCY USGS STATE 35 COUNTY 001
 LATITUDE 351149 LONGITUDE 1063827 NAD83 DRAINAGE AREA CONTRIBUTING DRAINAGE AREA DATUM 5050 NGVD29

Date Processed: 2007-05-09 09:38 By dcrilley

Rating for Discharge from dcp, IN cfs

RATING ID: 2.00 TYPE: stage-discharge EXPANSION: logarithmic STATUS: approved
 Created by mcarlson on 02-13-2006 @ 12:16:51 MST, Updated by lkmiller on 02-17-2006 @ 09:27:37 MST

Remarks: OFFSET: 1.00

EXPANDED RATING TABLE

Gage height, feet	Discharge IN cfs										DIFF IN Q PER .1 UNITS
	.00	.01	.02	.03	.04	.05	.06	.07	.08	.09	
10.50	100*	104	108	113	117	122	127	132	138	143	49.0
10.60	149	155	162	168	175	182	189	197	205	213	73.0
10.70	222	231	240	250	260	270*	276	282	288	294	78.0
10.80	300	307	314	320	327	334	341	349	356	364	71.0
10.90	371	379	387	396	404	413	421	430	439	449	87.0
11.00	458	468	478	488	498	508	519	530	541	552	106
11.10	564	576	588	600*	609	617	626	635	644	653	99.0
11.20	663	672	682	691	701	711	721	731	742	752	100
11.30	763	773	784	795	806	818	829	841	852	864	113
11.40	876	889	901	914	926	939	952	965	979	992	134
11.50	1010	1020	1030	1050	1060	1080	1090	1110	1120	1140	140
11.60	1150	1170	1180	1200	1220	1230	1250	1270	1290	1300	170
11.70	1320	1340	1360	1370	1390	1410	1430	1450	1470	1490	190
11.80	1510	1530	1550	1570	1590	1610	1630	1660	1680	1700	210
11.90	1720	1750	1770	1790	1820	1840	1870	1890	1920	1940	250
12.00	1970	1990	2020	2040	2070	2100	2130	2150	2180	2210	270
12.10	2240*	2250	2270	2280	2290	2310	2320	2330	2350	2360	140
12.20	2380	2390	2400	2420	2430	2450	2460	2470	2490	2500	140
12.30	2520	2530	2550	2560	2580	2590	2610	2620	2640	2650	150
12.40	2670	2680	2700	2710	2730	2740	2760	2780	2790	2810	150
12.50	2820	2840	2860	2870	2890	2910	2920	2940	2960	2970	170
12.60	2990	3010	3020	3040	3060	3070	3090	3110	3130	3140	170
12.70	3160	3180	3200	3210	3230	3250	3270	3290	3310	3320	180
12.80	3340	3360	3380	3400	3420	3440	3460	3470	3490	3510	190
12.90	3530	3550	3570	3590	3610	3630	3650	3670	3690	3710	200
13.00	3730	3750	3770	3790	3810	3830	3860	3880	3900	3920	210
13.10	3940	3960	3980	4000	4030	4050	4070	4090	4110	4140	220
13.20	4160	4180	4200	4230	4250	4270	4290	4320	4340	4360	230

USGS# 08329918 RIO GRANDE AT ALAMEDA BRIDGE, NM (Alameda Bridge Gauge)

Rating Table

p.2

U.S. DEPARTMENT OF THE INTERIOR - U.S. GEOLOGICAL SURVEY - WATER RESOURCES

STATION NUMBER 08329918 RIO GRANDE AT ALAMEDA BRIDGE AT ALAMEDA, NM SOURCE AGENCY USGS STATE 35 COUNTY 001
 LATITUDE 351149 LONGITUDE 1063827 NAD83 DRAINAGE AREA CONTRIBUTING DRAINAGE AREA DATUM 5050 NGVD29

Date Processed: 2007-05-09 09:38 By dcrilley

Rating for Discharge from dcp, IN cfs

RATING ID: 2.00 TYPE: stage-discharge EXPANSION: logarithmic STATUS: approved
 Created by mcarlson on 02-13-2006 @ 12:16:51 MST, Updated by lkmiller on 02-17-2006 @ 09:27:37 MST

Remarks: OFFSET: 1.00

EXPANDED RATING TABLE

Gage height, feet	Discharge IN cfs (STANDARD PRECISION)										DIFF IN Q PER
	.00	.01	.02	.03	.04	.05	.06	.07	.08	.09	.1 UNITS
13.30	4390	4410	4430	4460	4480*	4490	4510	4520	4540	4550	180
13.40	4570	4580	4600	4610	4620	4640	4650	4670	4680	4700	140
13.50	4710	4730	4740	4760	4770	4790	4800	4820	4830	4850	150
13.60	4860	4880	4890	4910	4920	4940	4960	4970	4990	5000	160
13.70	5020	5030	5050	5060	5080	5100	5110	5130	5140	5160	150
13.80	5170	5190	5210	5220	5240	5250	5270	5290	5300	5320	170
13.90	5340	5350	5370	5380	5400	5420	5430	5450	5470	5480	160
14.00	5500*	5520	5530	5550	5560	5580	5600	5610	5630	5650	160
14.10	5660	5680	5700	5710	5730	5750	5760	5780	5800	5810	170
14.20	5830	5850	5860	5880	5900	5920	5930	5950	5970	5980	170
14.30	6000	6020	6040	6050	6070	6090	6110	6120	6140	6160	180
14.40	6180	6190	6210	6230	6250	6260	6280	6300	6320	6340	170
14.50	6350	6370	6390	6410	6430	6440	6460	6480	6500	6520	180
14.60	6530	6550	6570	6590	6610	6630	6650	6660	6680	6700	190
14.70	6720	6740	6760	6780	6800	6810	6830	6850	6870	6890	190
14.80	6910	6930	6950	6970	6990	7010	7030	7040	7060	7080	190
14.90	7100	7120	7140	7160	7180	7200	7220	7240	7260	7280	200
15.00	7300*	7320	7330	7350	7370	7390	7400	7420	7440	7450	170
15.10	7470	7490	7510	7520	7540	7560	7570	7590	7610	7630	170
15.20	7640	7660	7680	7700	7710	7730	7750	7770	7790	7800	180
15.30	7820	7840	7860	7870	7890	7910	7930	7950	7960	7980	180
15.40	8000*										

"*" indicates a rating descriptor point

Rating Type:		Rating Type: stage-discharge	
ID	Starting Date	Ending Date	A Comments
2.00	10-14-2004 @ 14:39:00 MDT	09-30-2005 @ 23:59:59 MDT	W
2.00	10-01-2005 @ 00:00:00 MDT	09-30-2006 @ 23:59:59 MDT	A
2.00	10-01-2006 @ 00:00:00 MDT	-----	W

Bobcat (WU22)
Well Elevations at Ground Surface

East Well:	1523.60
South Well:	1523.23
West Well:	1523.69

**Bobcat (WU22) Well Cluster
Water Table and River Gauge Height
9/22/2006-3/31/2007: 15-Minute Data**

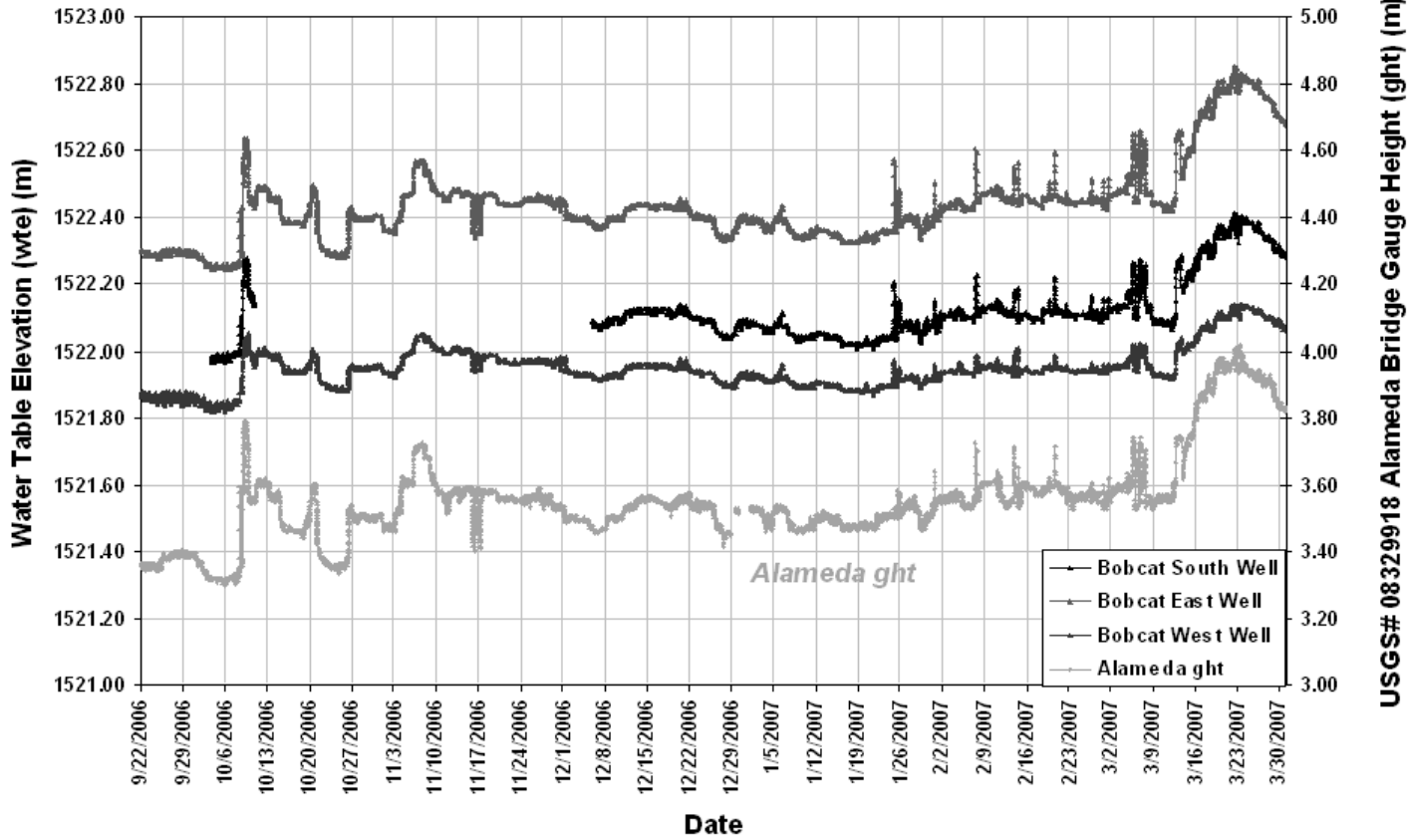
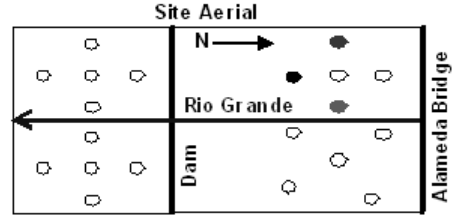

Bobcat (WU22) South Well wte (m)
 Statistics 9/22/2006-3/31/2007
 mean: 1522.12
 stdv: 0.10
 min: 1521.97
 max: 1522.42

**Bobcat (WU22) South Well
 Water Table and River Gauge Height
 9/22/2006-3/31/2007: 15-Minute Data**

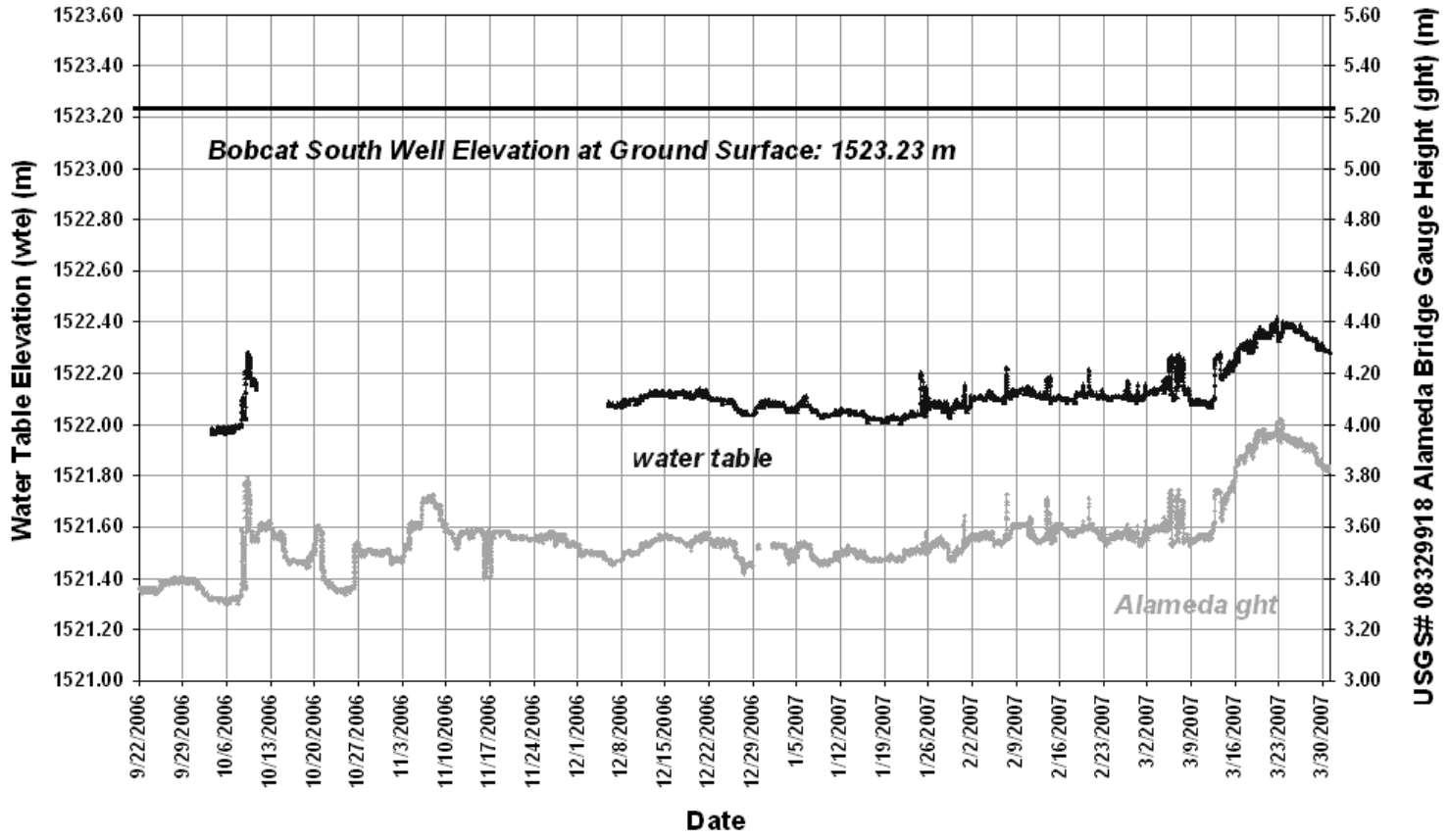
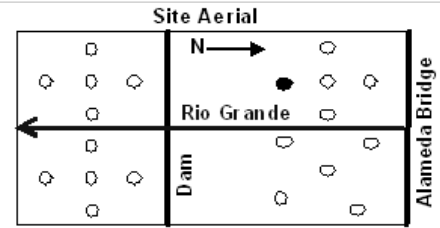

Bobcat (WU22) West Well wte (m)
 Statistics 9/22/2006-3/31/2007
 mean: 1521.95
 stdv: 0.06
 min: 1521.82
 max: 1522.14

**Bobcat (WU22) West Well
 Water Table and River Gauge Height
 9/22/2006-3/31/2007: 15-Minute Data**

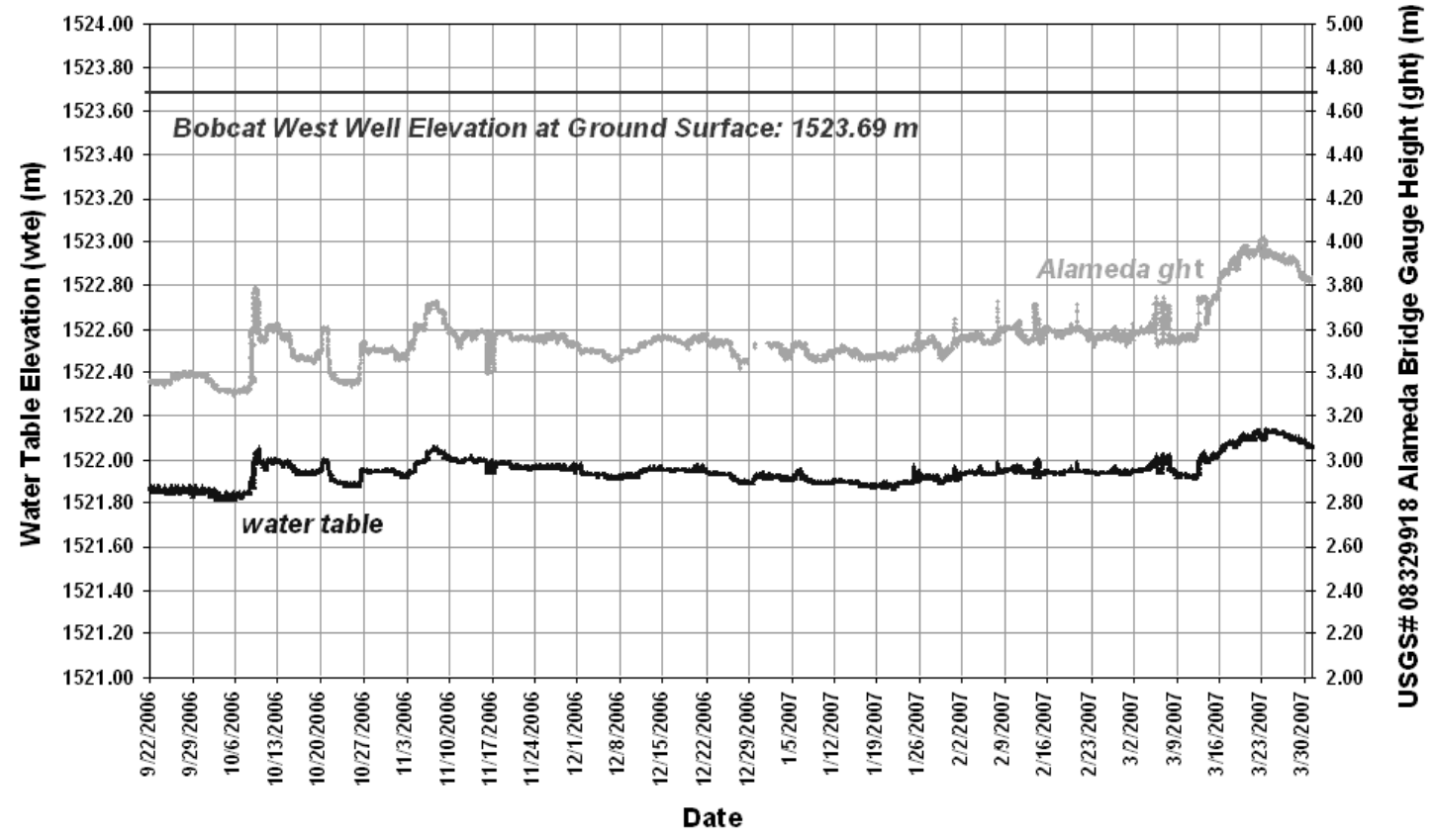
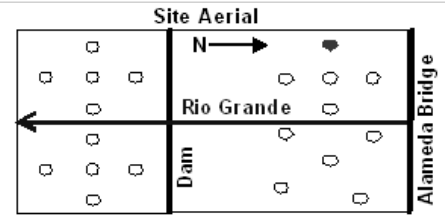

Bobcat (WU22) East Well wte (m)
 Statistics 9/22/2006-3/31/2007
 mean: 1522.44
 stdv: 0.12
 min: 1522.24
 max: 1522.85

**Bobcat (WU22) East Well
 Water Table and River Gauge Height
 9/22/2006-3/31/2007: 15-Minute Data**

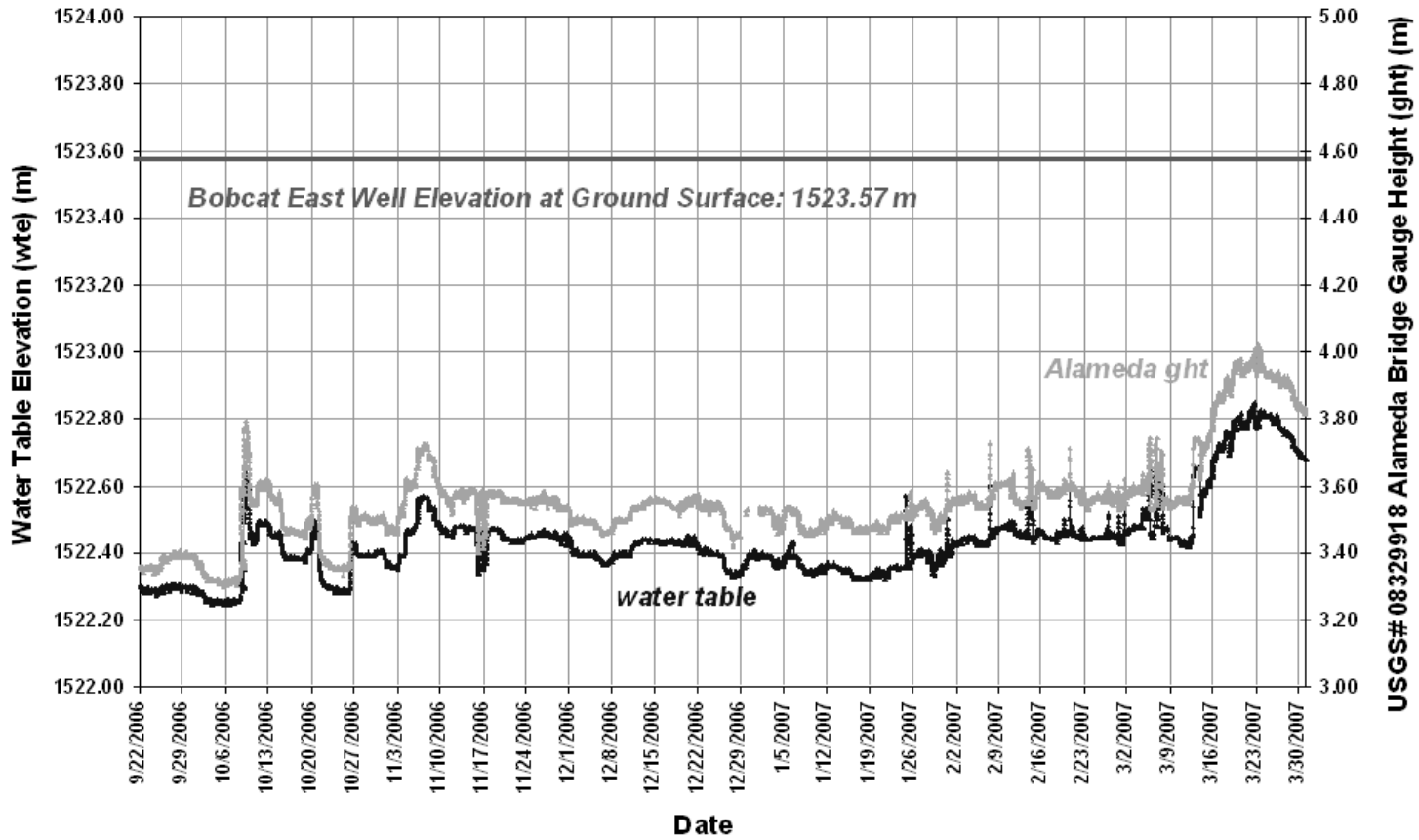
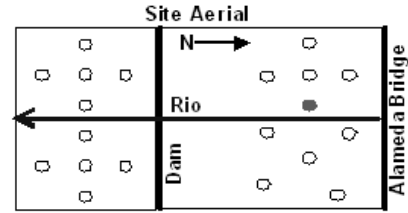

Bobcat (WU22) Center Well wte (m)
 Statistics 9/22/2006-3/31/2007
 mean: 1522.17
 stdv: 0.08
 min: 1521.97
 max: 1522.45

**Bobcat (WU22) Center Well
 Water Table and River Gauge Height
 9/22/2006-3/31/2007: 30-Minute Data**

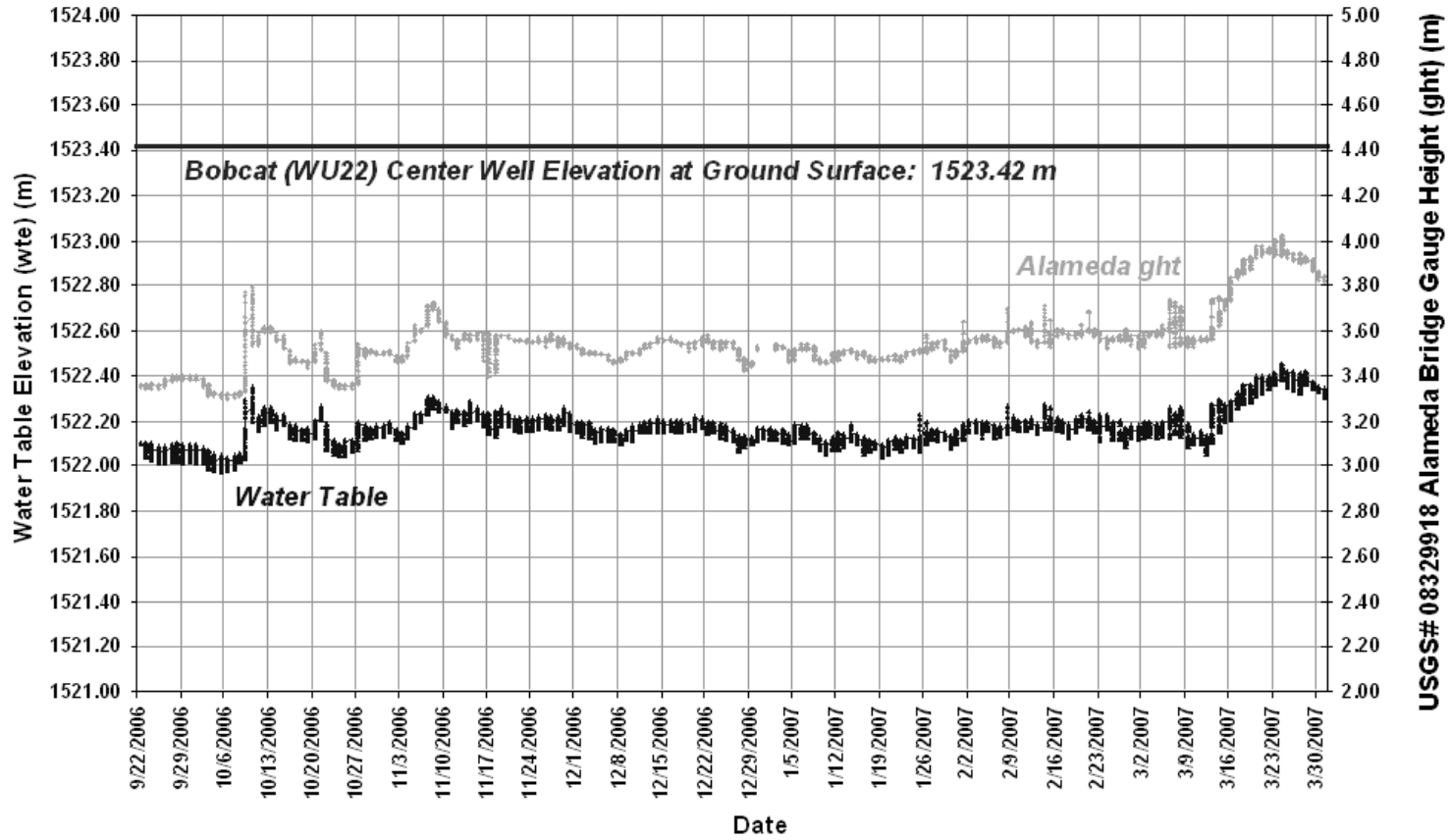
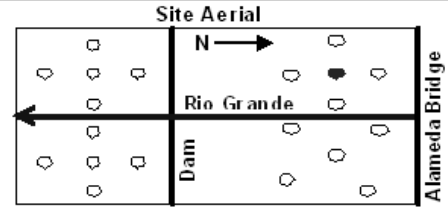

Badger (EU21) Well Cluster
 Well Elevations at Ground Surface
 West Well: 1523.81
 East Well: 1523.37
 South Well: 1523.36

**Badger (EU21) Well Cluster
 Water Table and River Gauge Height
 9/22/2006-3/31/2007: 15-Minute Data**

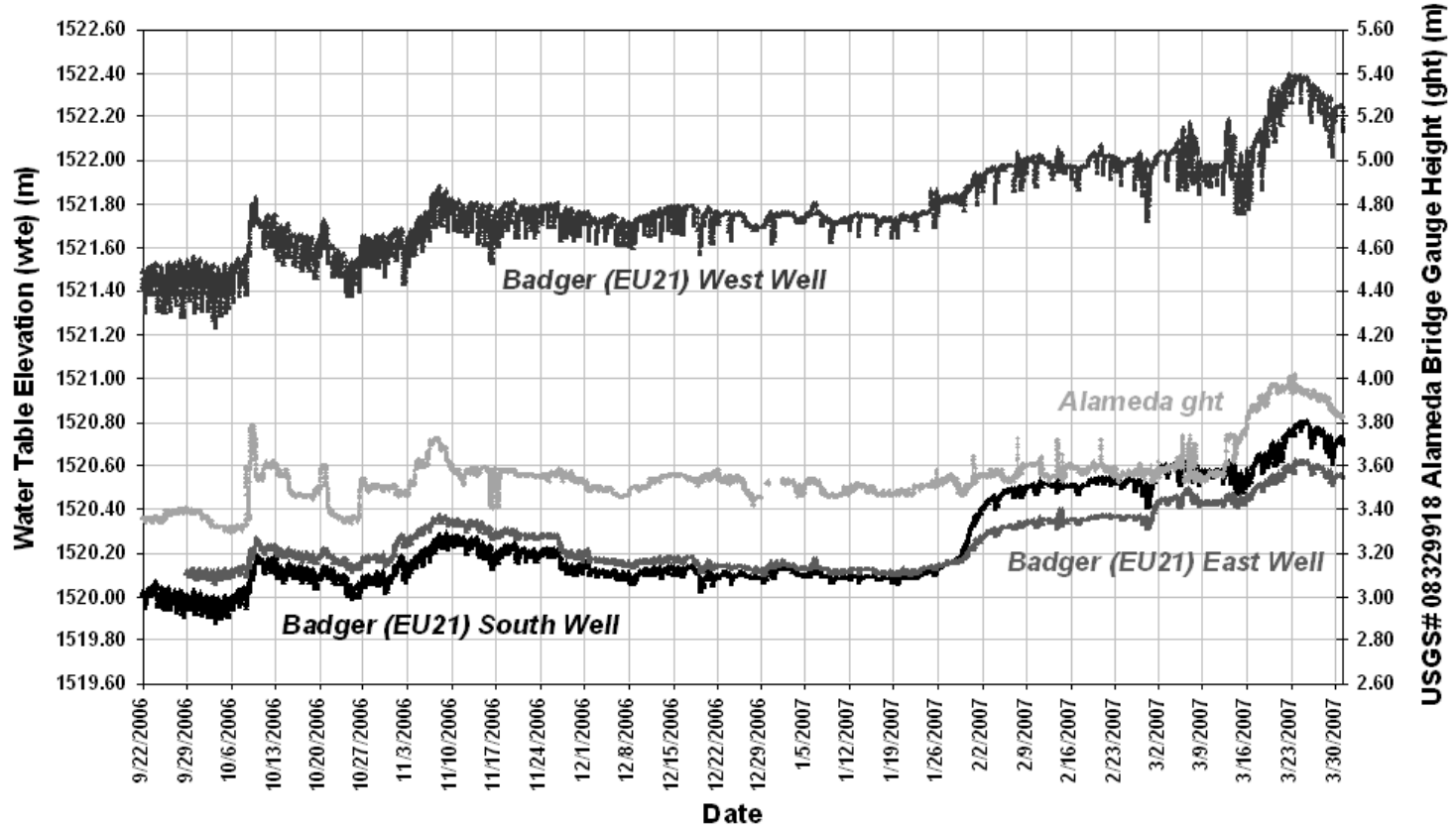
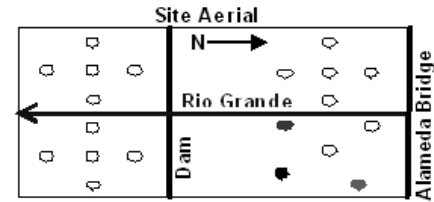

Badger (EU21) South Well wte (m)
 Statistics 9/22/2006-3/31/2007
 mean: 1520.25
 stdv: 0.23
 min: 1519.89
 max: 1520.80

**Badger (EU21) South Well
 Water Table and River Gauge Height
 9/22/2006-3/31/2007: 15-Minute Data**

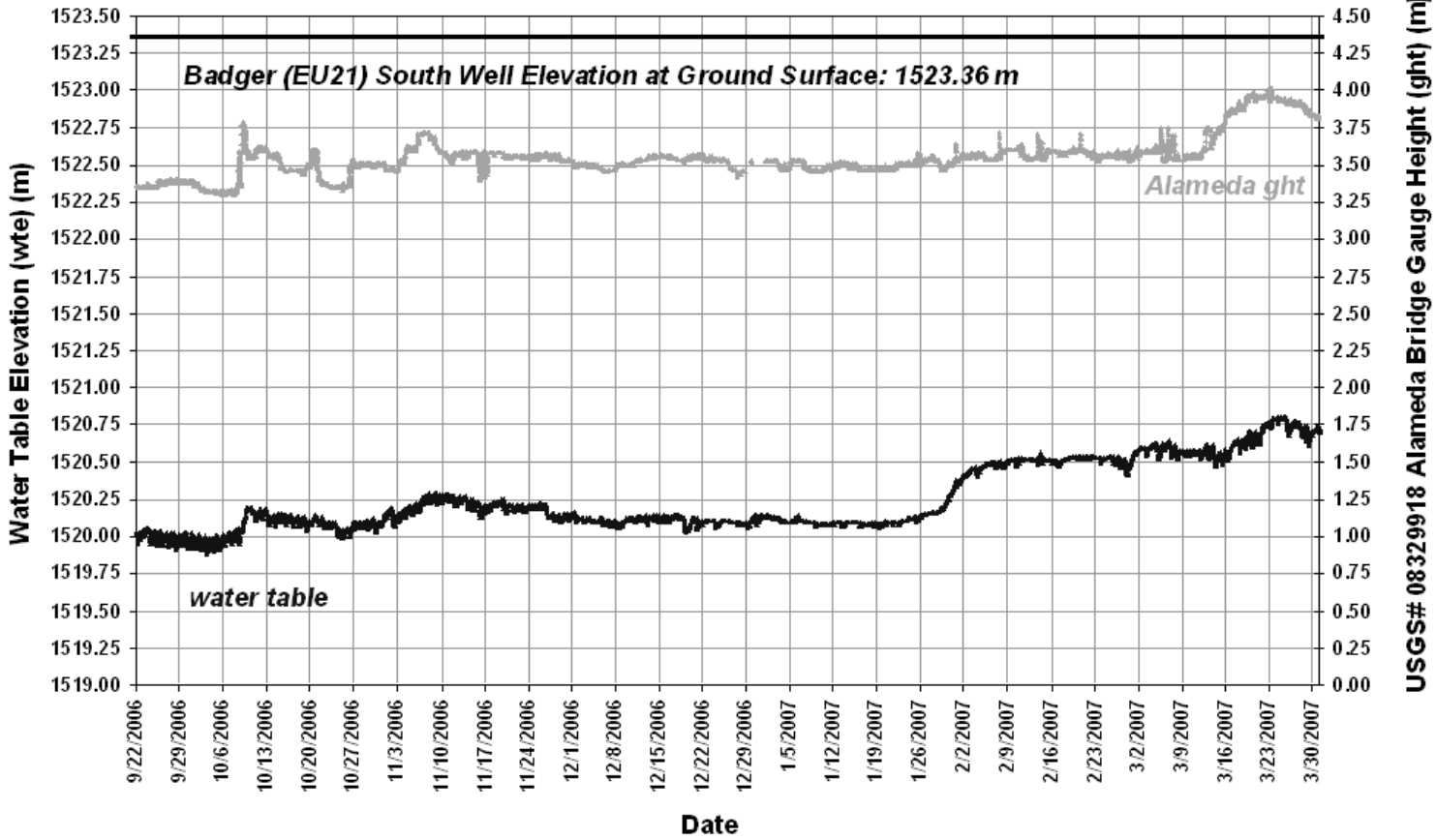
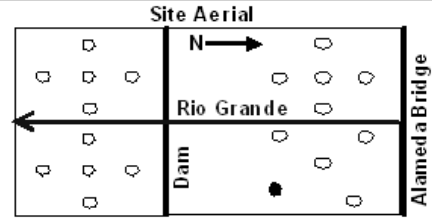

Badger (EU21) West Well wte (m)
 Statistics 9/22/2006-3/31/2007
 mean: 1521.80
 stdv: 0.21
 min: 1521.24
 max: 1522.40

**Badger (EU21) West Well
 Water Table and River Gauge Height
 9/22/2006-3/31/2007: 15-Minute Data**

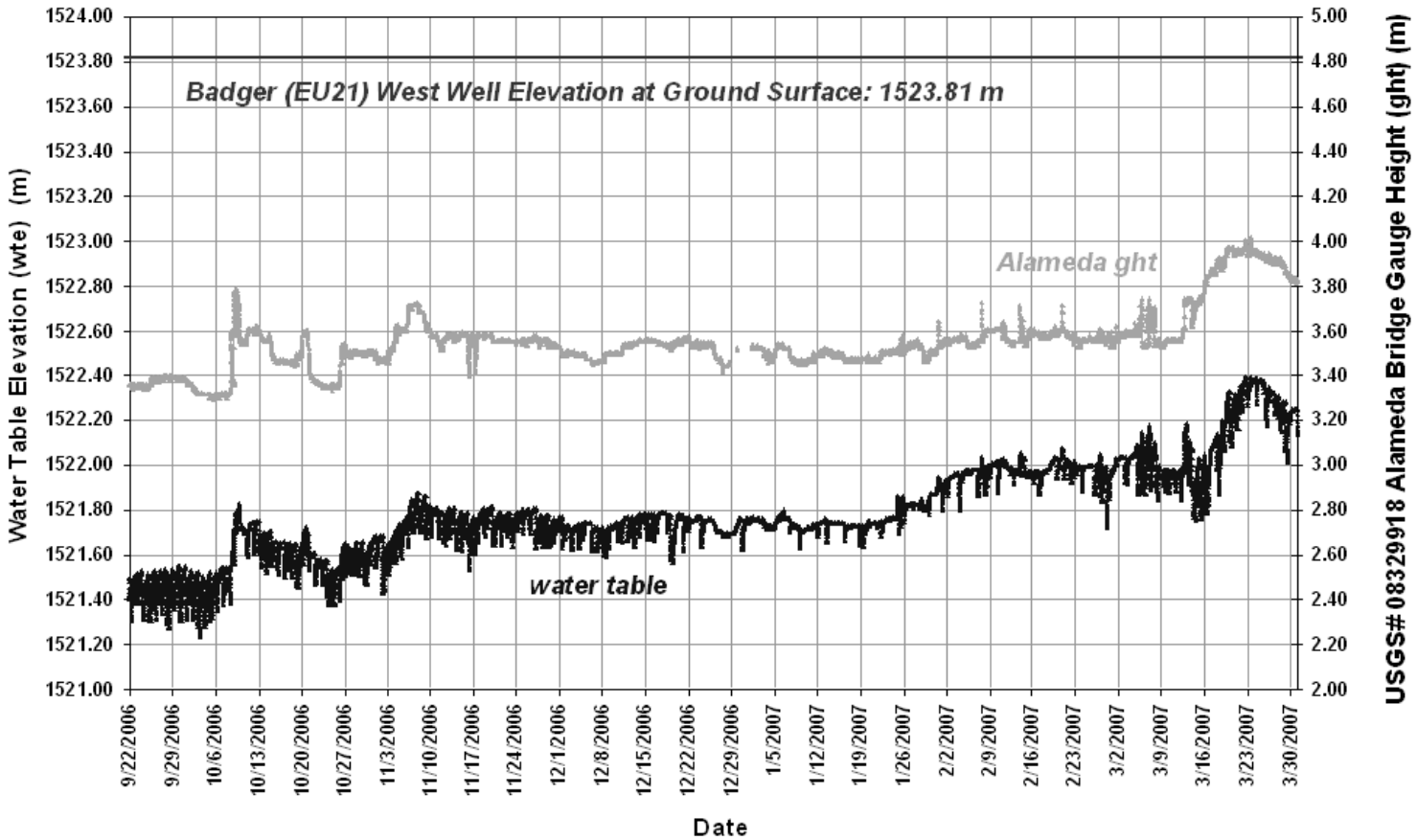
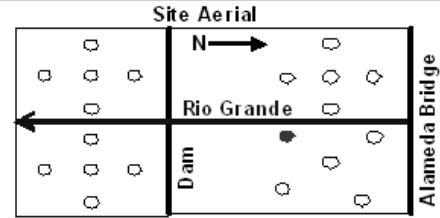

Bobcat (WU22) East Well wte (m)
 Statistics 9/22/2006-3/31/2007
 mean: 1522.44
 stdv: 0.12
 min: 1522.24
 max: 1522.85

**Bobcat (WU22) East Well
 Water Table and River Gauge Height
 9/22/2006-3/31/2007: 15-Minute Data**

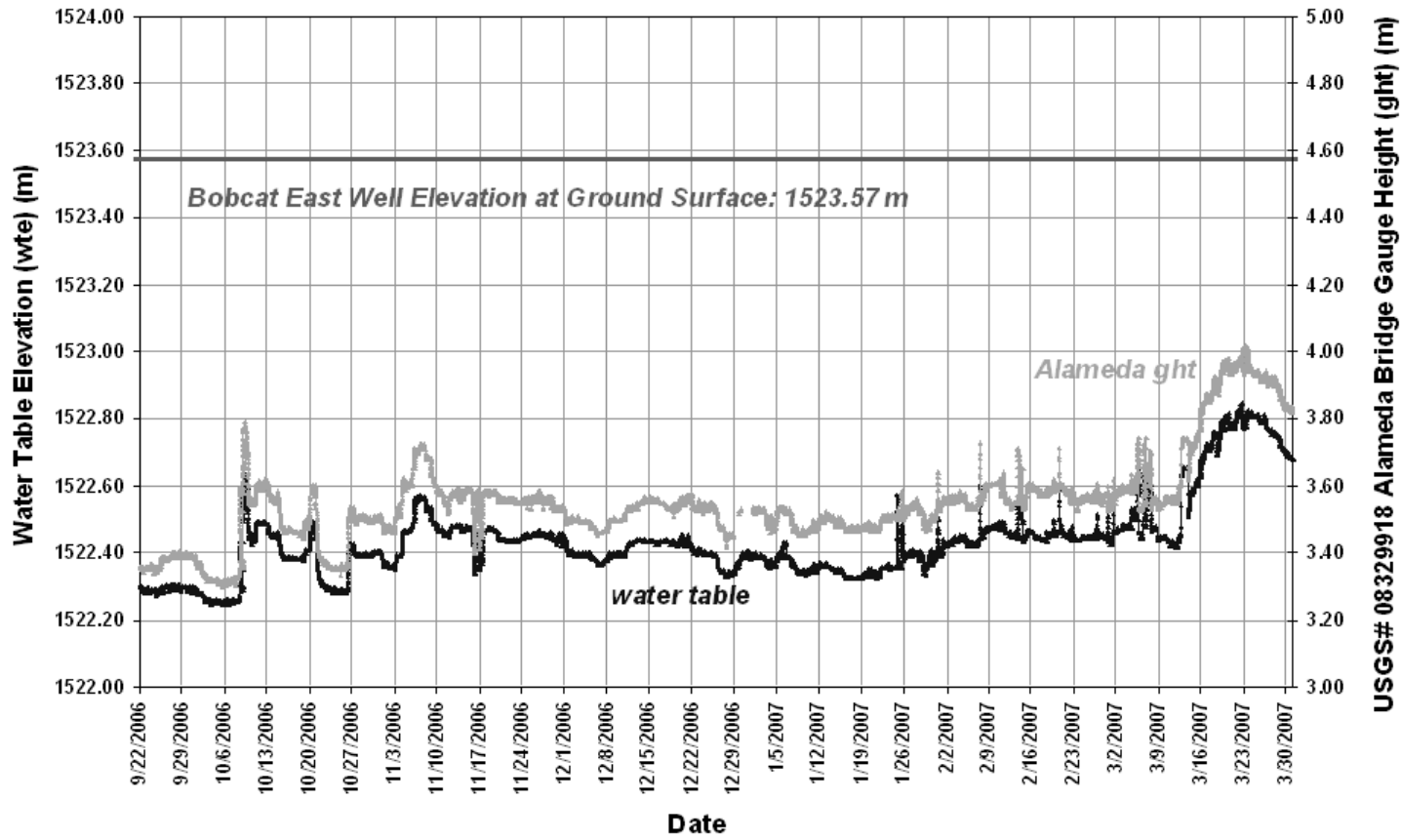
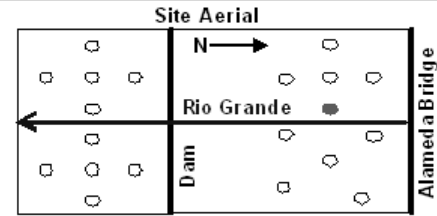

Badger (EU21) Center Well wte (m)
 Statistics 9/22/2006-3/31/2007
 mean: 1520.81
 stdv: 0.16
 min: 1520.51
 max: 1521.29

**Badger (EU21) Center Well
 Water Table and River Gauge Height
 9/22/2006-3/31/2007: 30-Minute Data**

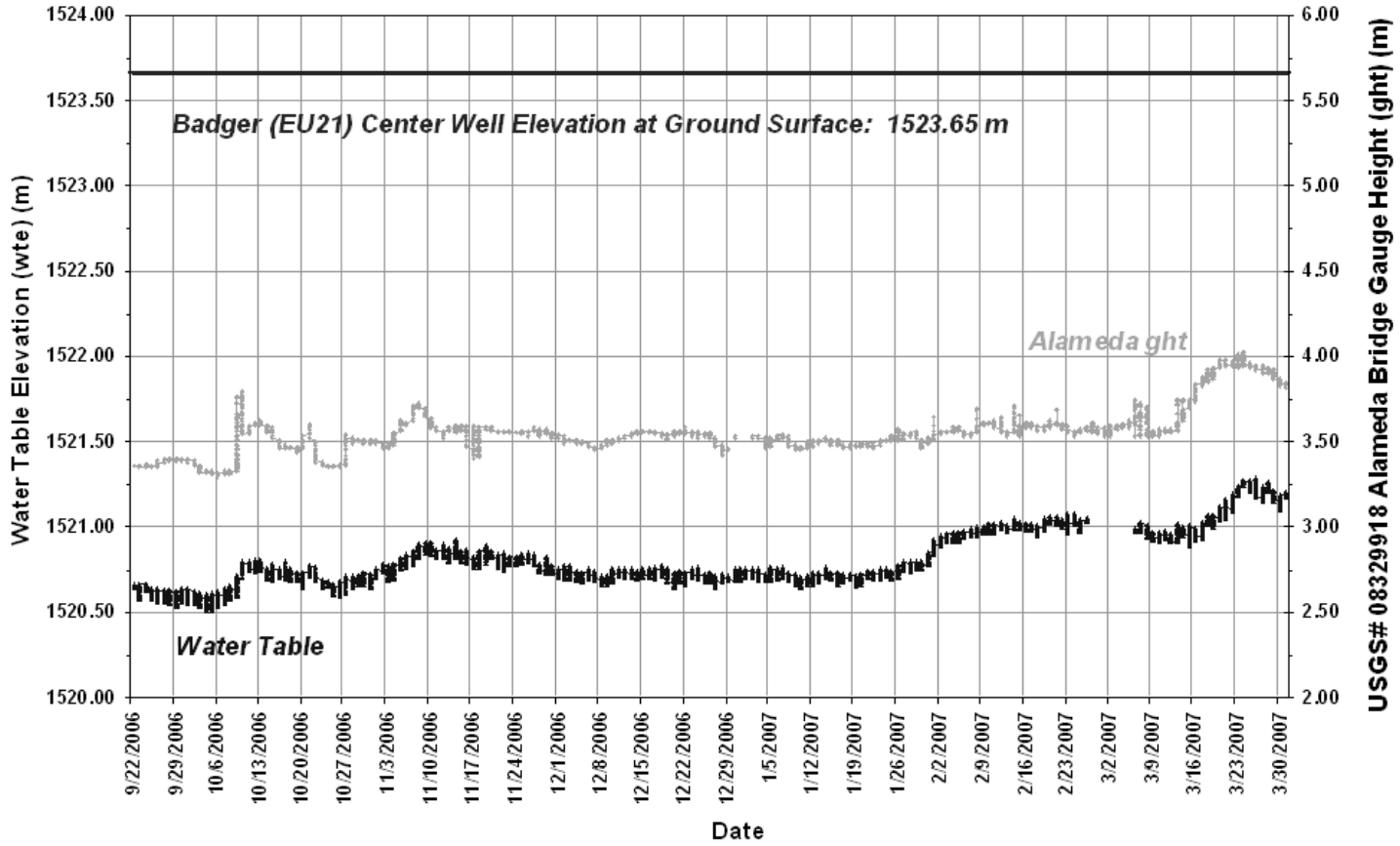
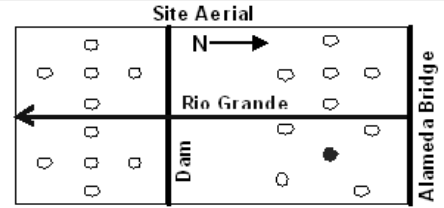

Location Map

USGS River Gauge #08329928 Rio Grande at Paseo del Norte Bridge

Bernalillo County, New Mexico

Hydrologic Unit Code 13020203

Latitude 35°10'55", Longitude 106°39'04" NAD83

Gage datum 4,990 feet above sea level NGVD29

Date of Record Start: March, 1989

Location of the site in USA.

Site map.

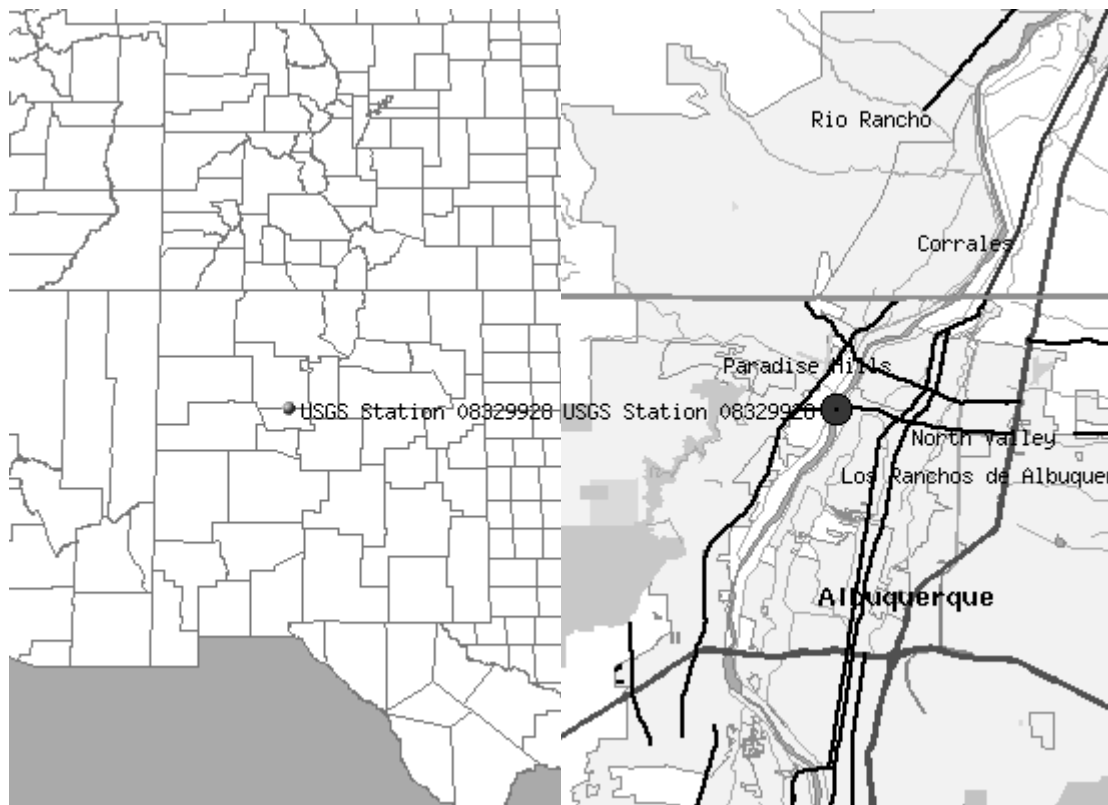

Maps are generated by [US Census Bureau TIGER Mapping Service](#).

*Revised from USGS National Water Information System New Mexico Web Interface http://waterdata.usgs.gov/nwis/nwismap/?site_no=08329928

Paseo Bridge Gauge Height
Statistics: 9/22/2006-3/31/2007
mean: 1.22 m
stdv: 0.12 m
min: 0.97 m
max: 1.63 m

USGS River Gauge #08329928
Rio Grande at Paseo del Norte Bridge (South of DWD)
15-Minute Data: Observation Period 9/22/2006-3/31/2007

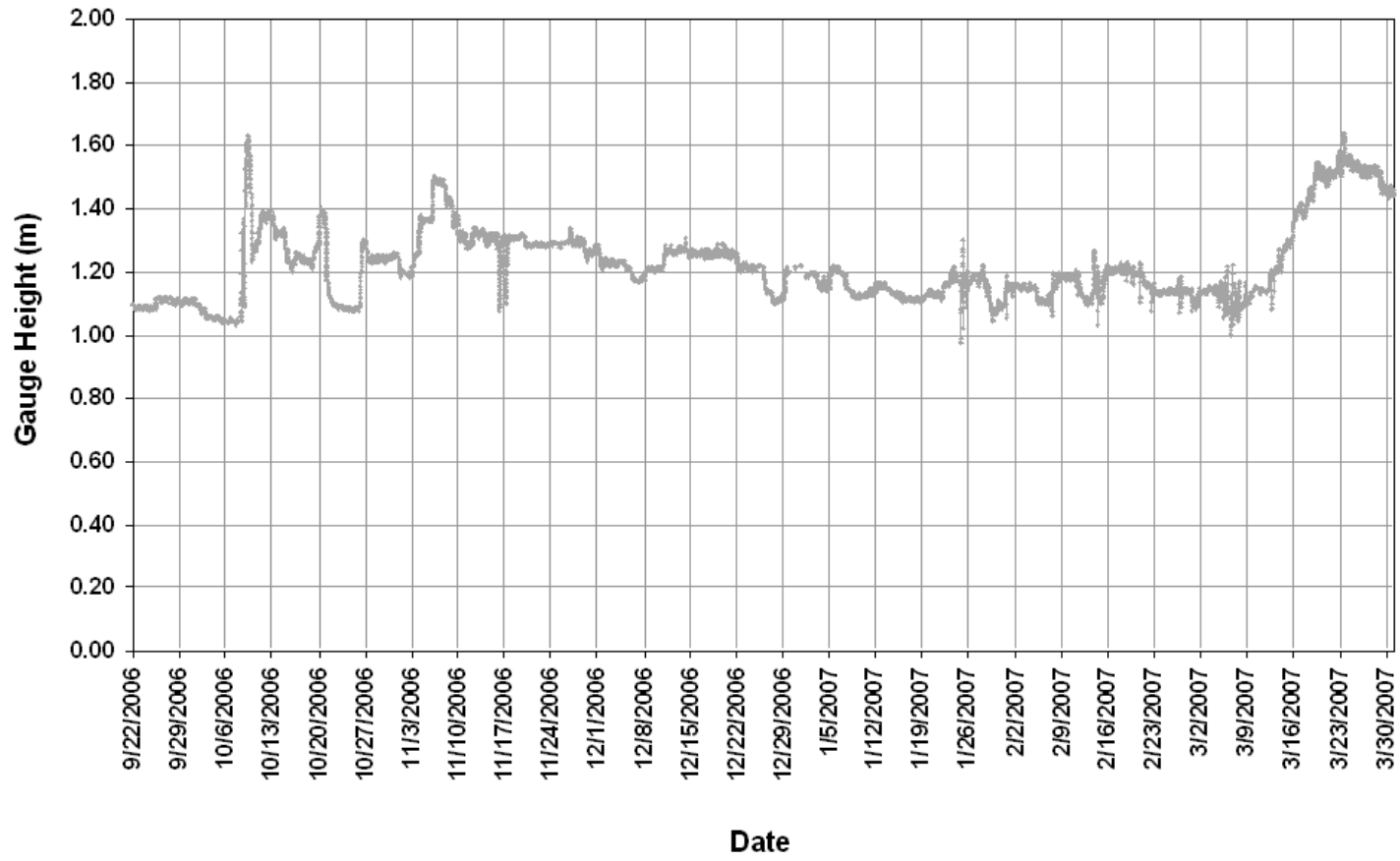

USGS# 08329928 RIO GRANDE NR ALAMEDA, NM (Paseo Bridge Gauge)

Rating Table

p.1

U.S. DEPARTMENT OF THE INTERIOR - U.S. GEOLOGICAL SURVEY - WATER RESOURCES

STATION NUMBER 08329928 RIO GRANDE NR ALAMEDA, NM SOURCE AGENCY USGS STATE 35 COUNTY 001
 LATITUDE 351055 LONGITUDE 1063904 NAD83 DRAINAGE AREA CONTRIBUTING DRAINAGE AREA DATUM 4990 NGVD29

Date Processed: 2007-05-09 09:48 By dcrilley

Rating for Discharge from dcp, IN cfs

RATING ID: 4.10 TYPE: stage-discharge EXPANSION: logarithmic STATUS: approved
 Created by mcarlson on 05-25-2005 @ 17:03:53 MDT, Updated by lkmiller on 02-09-2006 @ 09:35:08 MST
 Remarks: Extension of rating #4.00, OFFSET: 1.50

EXPANDED RATING TABLE

Gage height, feet	Discharge IN cfs (STANDARD PRECISION)										DIFF IN Q PER
	.00	.01	.02	.03	.04	.05	.06	.07	.08	.09	.1 UNITS
2.20	40.0*	41.5	43.1	44.7	46.3	48.0	49.7	51.4	53.2	55.0	16.9
2.30	56.9	58.8	60.7	62.7	64.7	66.7	68.8	70.9	73.1	75.3	20.7
2.40	77.6	79.8	82.2	84.5	87.0	89.4	91.9	94.5	97.1	99.7	24.4
2.50	102	105	108	111	113	116	119	122	125	128	30.0
2.60	132	135	138	141	145	148	151	155	158	162	33.0
2.70	165	169	173	177	180	184	188	192	196	200	39.0
2.80	204	208	213	217	221	226	230	235	239	244	44.0
2.90	248	253	258	263	267	272	277	282	287	293	50.0
3.00	298	303	308	314	319	325	330	336	342	347	55.0
3.10	353	359	365	371	377	383	389	395	401	408	61.0
3.20	414	421	427	434	440	447	454	461	467	474	67.0
3.30	481	489	496	503	510	517	525	532	540	547	74.0
3.40	555	563	571	579	586	594	603	611	619	627	80.0
3.50	635	644	652	661	669	678	687	696	705	714	88.0
3.60	723	732	741	750	759	769	778	788	797	807	94.0
3.70	817	827	837	846	857	867	877	887	897	908	101
3.80	918	929	939	950	961	972	983	994	1000	1020	112
3.90	1030	1040	1050	1060	1070	1080	1100	1110	1120	1130	110
4.00	1140	1160	1170	1180	1190	1210	1220	1230	1240	1260	130
4.10	1270	1280	1290	1310	1320	1330	1350	1360	1370	1390	130
4.20	1400	1410	1430	1440	1460	1470	1480	1500	1510	1530	140
4.30	1540	1560	1570	1590	1600	1620	1630	1650	1660	1680	150
4.40	1690	1710	1720	1740	1750	1770	1780	1800	1820	1830	160
4.50	1850	1870	1880	1900	1910	1930	1950	1960	1980	2000	170
4.60	2020	2030	2050	2070	2090	2100	2120	2140	2160	2170	170
4.70	2190	2210	2230	2250	2260	2280	2300	2320	2340	2360	190
4.80	2380	2400	2410	2430	2450	2470	2490	2510	2530	2550	190
4.90	2570	2590	2610	2630	2650	2670	2690	2710	2730	2750	210
5.00	2780	2800	2820	2840	2860	2880	2900	2920	2950	2970	210
5.10	2990	-3010	3030	3060	3080	3100	3120	3140	3170	3190	220

USGS# 08329928 RIO GRANDE NR ALAMEDA, NM (Paseo Bridge Gauge)

Rating Table

p.2

U.S. DEPARTMENT OF THE INTERIOR - U.S. GEOLOGICAL SURVEY - WATER RESOURCES

STATION NUMBER 08329928 RIO GRANDE NR ALAMEDA, NM STREAM SOURCE AGENCY USGS STATE 35 COUNTY 001
 LATITUDE 351055 LONGITUDE 1063904 NAD83 DRAINAGE AREA CONTRIBUTING DRAINAGE AREA DATUM 4990 NGVD29

Date Processed: 2007-05-09 09:48 By dcrilley

Rating for Discharge from dcp, IN cfs

RATING ID: 4.10 TYPE: stage-discharge EXPANSION: logarithmic STATUS: approved
 Created by mcarlson on 05-25-2005 @ 17:03:53 MDT, Updated by lkmiller on 02-09-2006 @ 09:35:08 MST
 Remarks: Extension of rating #4.00, OFFSET: 1.50

EXPANDED RATING TABLE

Gage height, feet	Discharge IN cfs (STANDARD PRECISION)										DIFF IN Q PER UNITS
	.00	.01	.02	.03	.04	.05	.06	.07	.08	.09	.1
5.20	3210	3240	3260	3280	3310	3330	3350	3380	3400	3420	240
5.30	3450	3470	3490	3520	3540	3570	3590	3620	3640	3670	240
5.40	3690	3720	3740	3770	3790	3820	3840	3870	3890	3920	260
5.50	3950	3970	4000	4020	4050	4080	4100	4130	4160	4180	260
5.60	4210	4240	4260	4290	4320	4350	4370	4400	4430	4460	280
5.70	4490	4510	4540	4570	4600	4630	4660	4690	4710	4740	280
5.80	4770	4800	4830	4860	4890	4920	4950	4980	5010	5040	300
5.90	5070	5100	5130	5160	5190	5220	5260	5290	5320	5350	310
6.00	5380	5410	5440	5480	5510	5540	5570	5600	5640	5670	320
6.10	5700	5730	5770	5800	5830	5870	5900	5930	5970	6000	330
6.20	6030	6070	6100	6140	6170	6200	6240	6270	6310	6340	350
6.30	6380	6410	6450	6480	6520	6550	6590	6630	6660	6700	350
6.40	6730	6770	6810	6840	6880	6920	6950	6990	7030	7060	370
6.50	7100	7140	7180	7210	7250	7290*	7340	7380	7430	7470	420
6.60	7520	7560	7610	7660	7700	7750	7800	7850	7890	7940	470
6.70	7990	8040	8090	8130	8180	8230	8280	8330	8380	8430	490
6.80	8480	8530	8580	8630	8680	8730	8780	8830	8890	8940	510
6.90	8990	9040	9090	9150	9200	9250	9310	9360	9410	9470	530
7.00	9520	9580	9630	9680	9740	9790	9850	9910	9960	10000	580
7.10	10100	10100	10200	10200	10300	10400	10400	10500	10500	10600	500
7.20	10600	10700	10800	10800	10900	10900	11000	11100	11100	11200	600
7.30	11200	11300	11400	11400	11500	11500	11600	11700	11700	11800	700
7.40	11900	11900	12000	12000	12100	12200	12200	12300	12400	12400	600
7.50	12500*										

"*" indicates a rating descriptor point

Rating Type:		Rating Type: stage-discharge		A Comments
ID	Starting Date	Ending Date		
4.10	04-12-2005 @ 15:00:00 MDT	09-30-2006 @ 23:59:59 MDT	A	rating extension
4.10	10-01-2006 @ 00:00:00 MDT	-----	W	rating extension

Minnow (WD12) Well Elevations at Ground Surface	
East Well:	1523.02
North Well:	1523.03
Center Well:	1523.00
West Well:	1523.20

Minnow (WD12) Well Cluster Water Table and River Gauge Height 9/22/2006-3/31/2007: 15-Minute Data

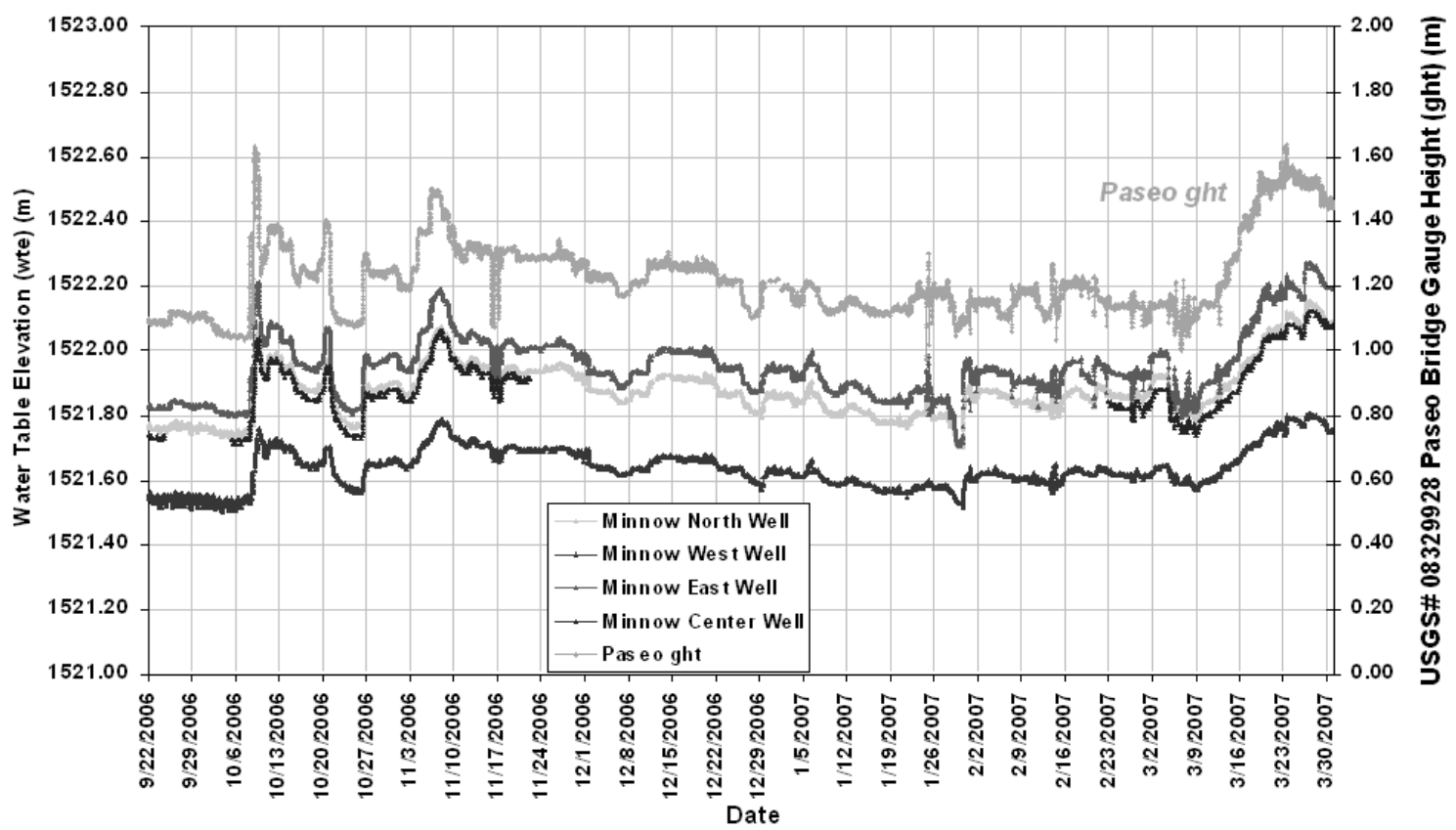
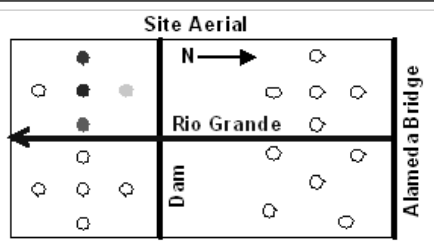

Minnow (WD12) North Well wte (m)
 Statistics 9/22/2006-3/31/2007
 mean: 1521.88
 stdv: 0.09
 min: 1521.70
 max: 1522.15

**Minnow (WD12) North Well
 Water Table and River Gauge Height
 9/22/2006-3/31/2007: 15-Minute Data**

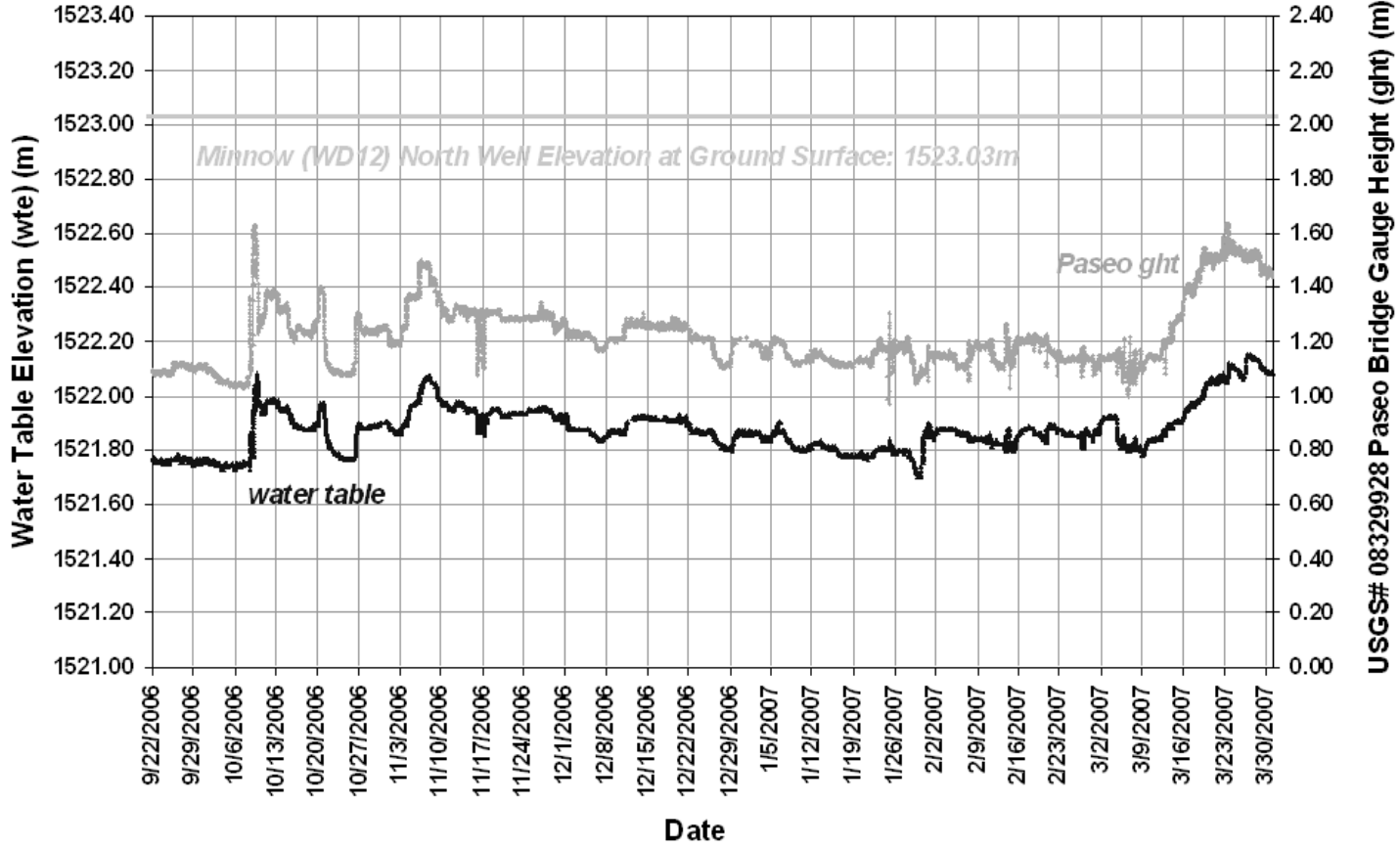
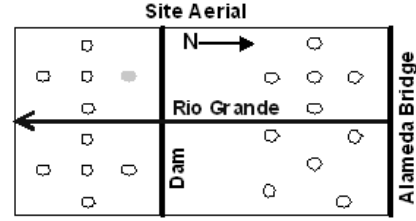

Minnow (WD12) West Well wte (m)
 Statistics 9/22/2006-3/31/2007
 mean: 1521.64
 stdv: 0.06
 min: 1521.50
 max: 1522.80

**Minnow (WD12) West Well
 Water Table and River Gauge Height
 9/22/2006-3/31/2007: 15-Minute Data**

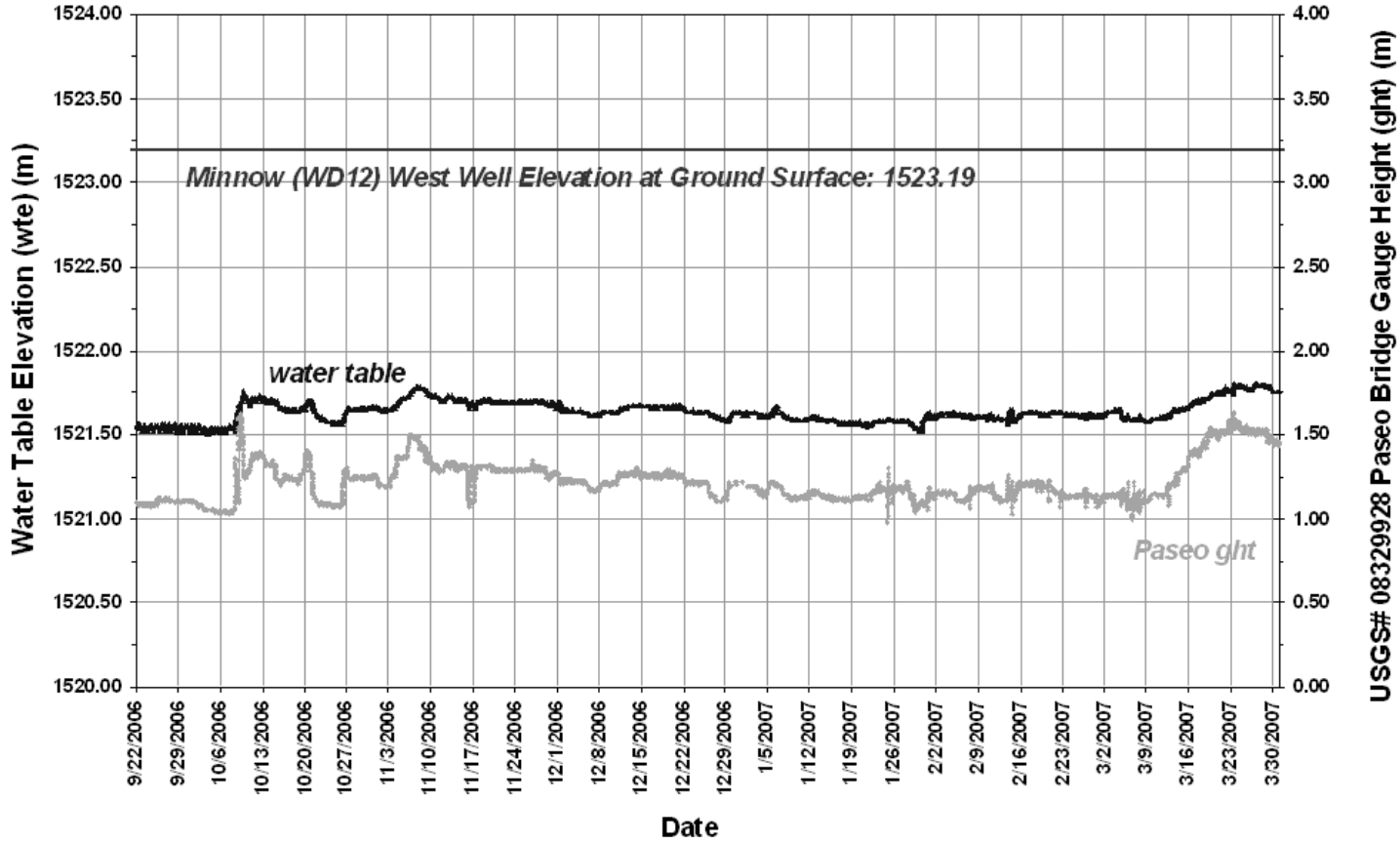
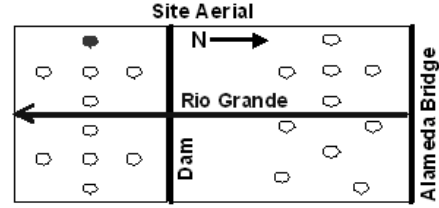

Minnow (WD12) East Well wte (m)
 Statistics 9/22/2006-3/31/2007
 mean: 1521.95
 stdv: 0.10
 min: 1521.71
 max: 1522.27

**Minnow (WD12) East Well
 Water Table and River Gauge Height
 9/22/2006-3/31/2007: 15-Minute Data**

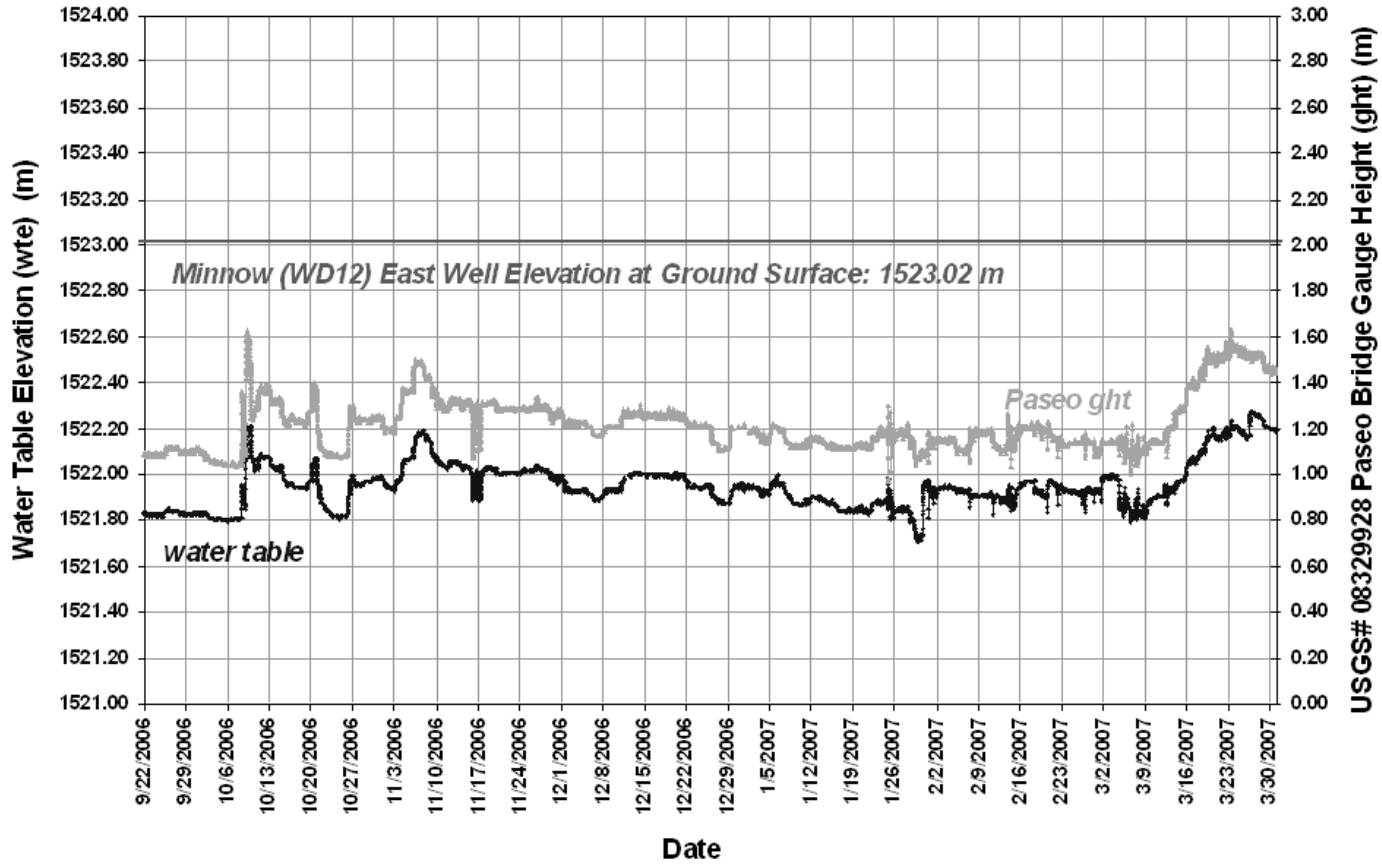
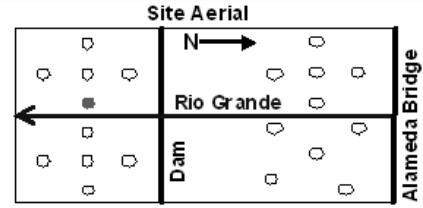

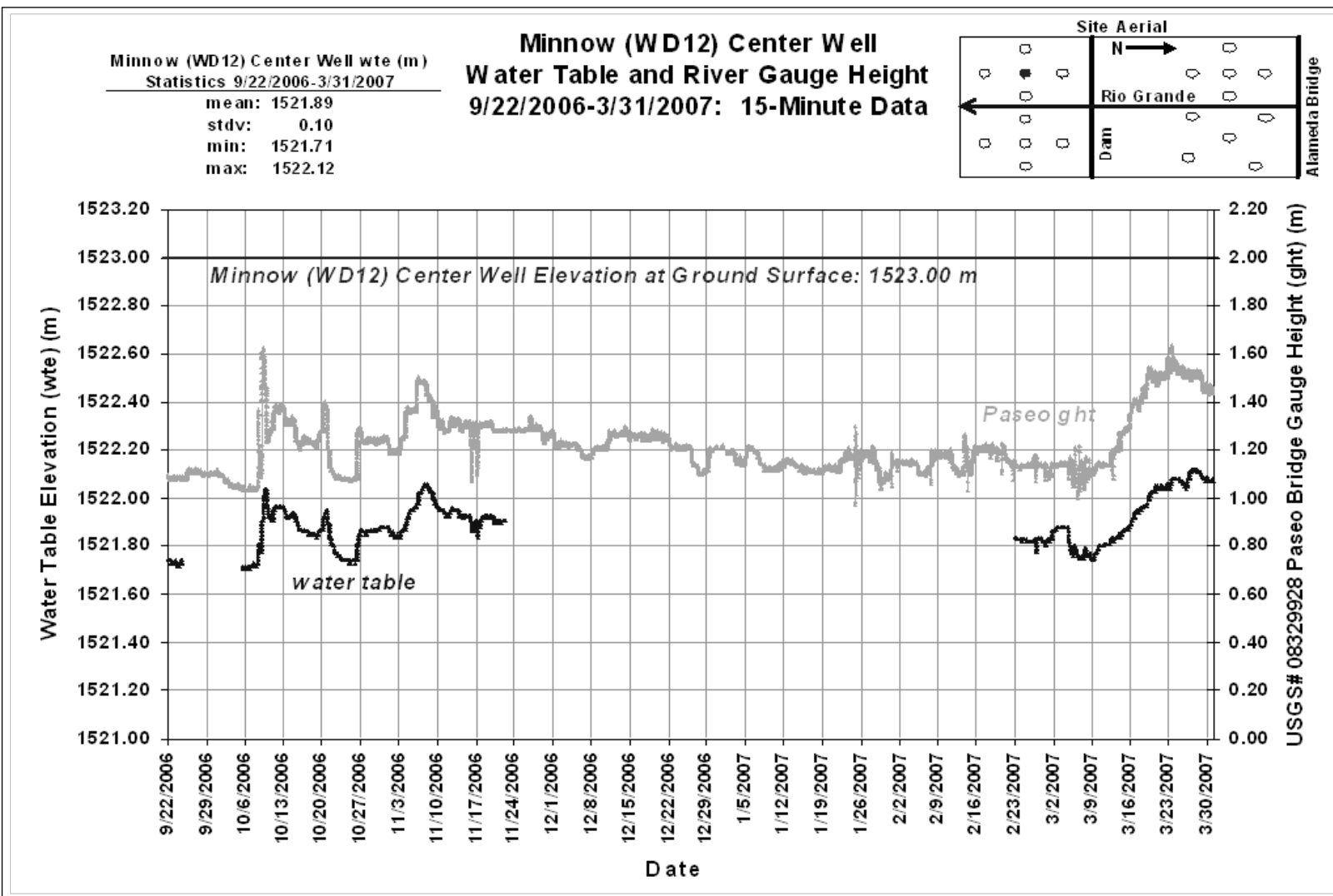

*The range of missing data for this logger was due to a malfunction with the Sutron data device at this site.

Diversion (ED10)
 Well Elevations at Ground Surface
 West Well: 1523.07
 North Well: 1522.71
 East Well: 1523.10

Diversion (ED10) Well Cluster
Water Table and River Gauge Height
9/22/2006-3/31/2007: 15-Minute Data

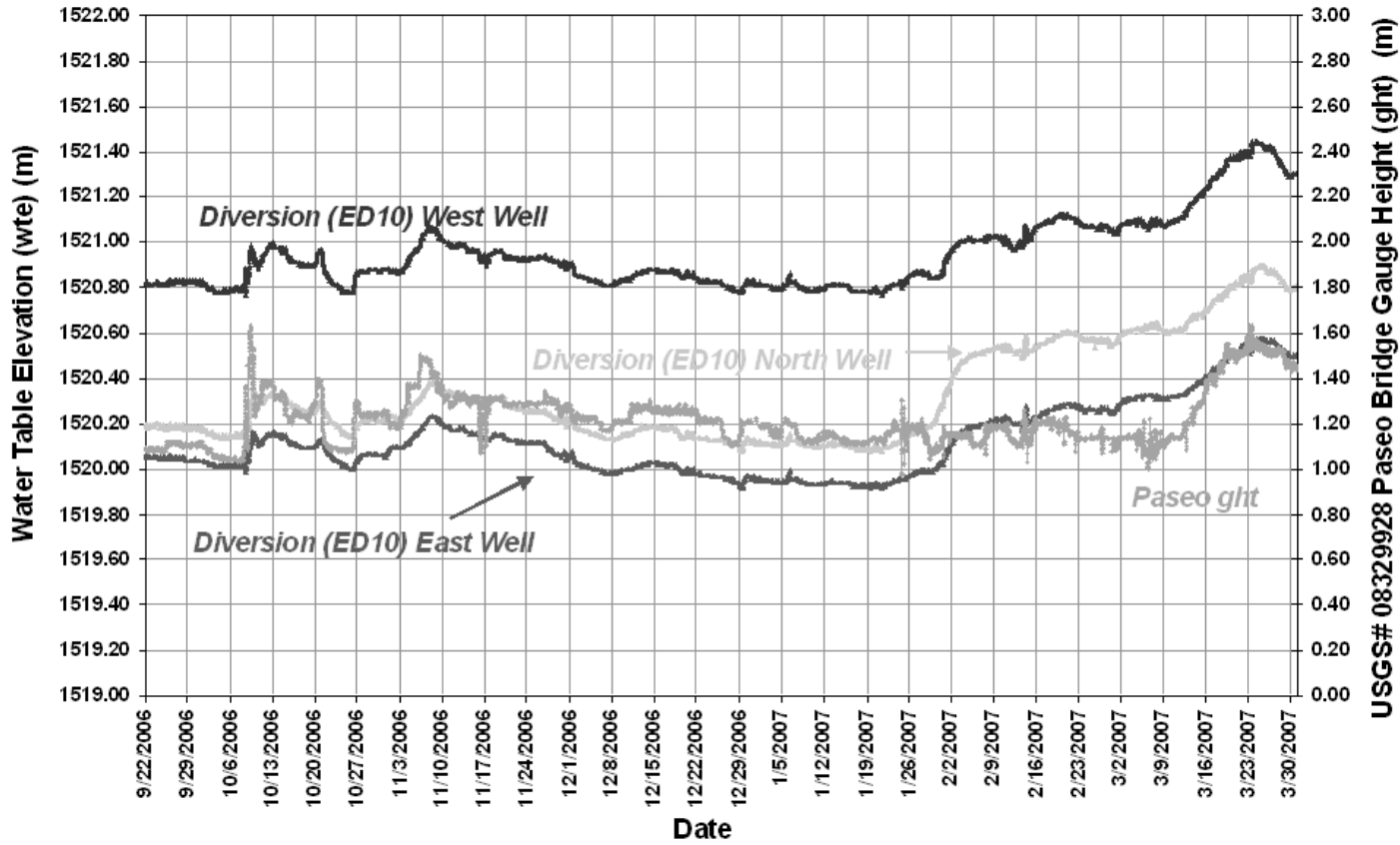
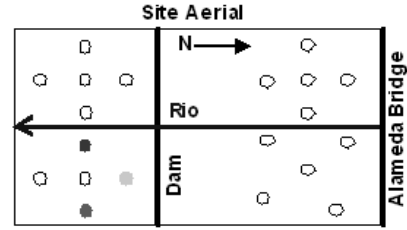

Diversion (ED10) North Well
 Statistics 9/22/2006-3/31/2007

mean: 1520.33
 stdv: 0.22
 min: 1520.08
 max: 1520.90

**Diversion (ED10) North Well
 Water Table and River Gauge Height
 9/22/2006-3/31/2007: 15-Minute Data**

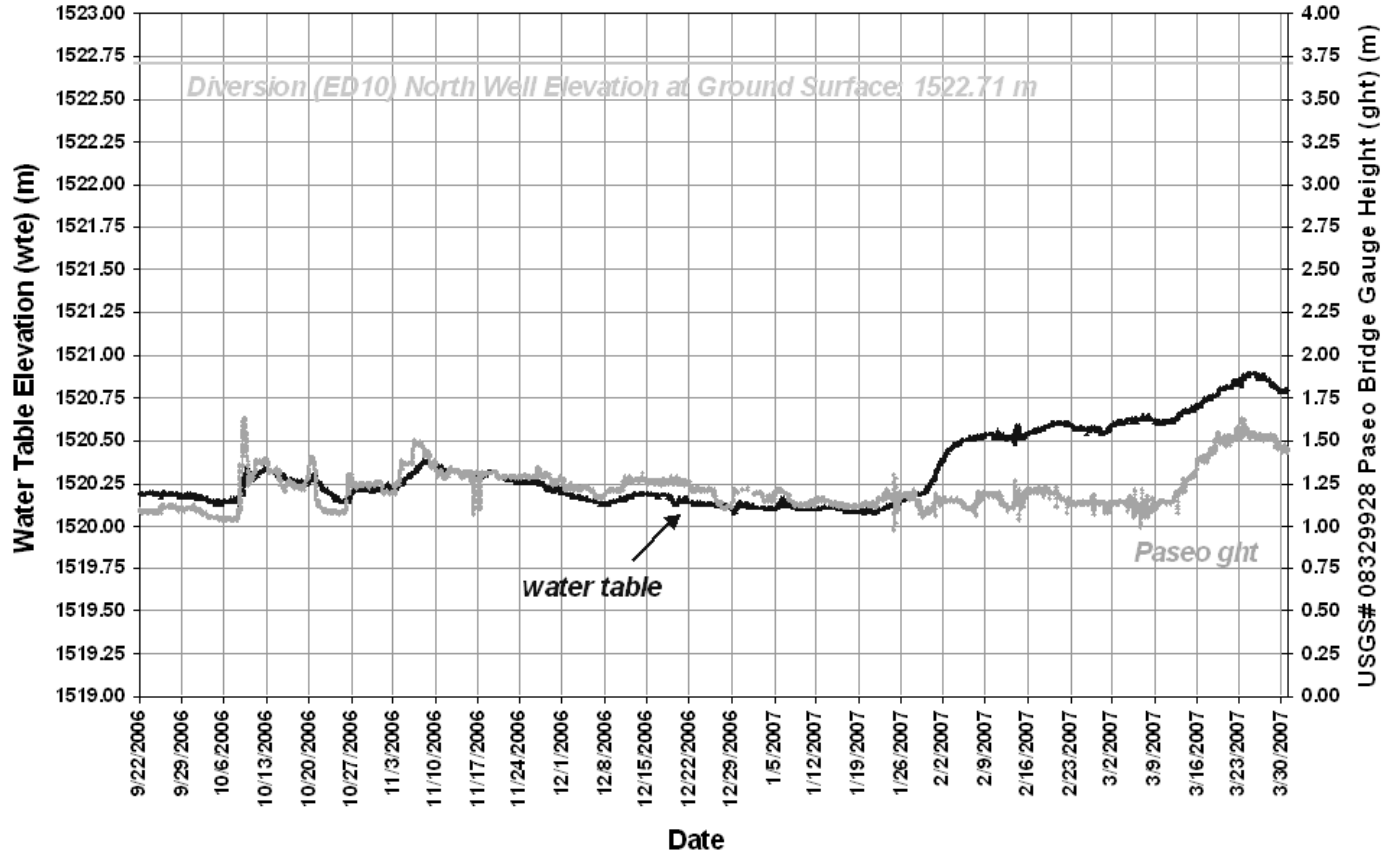
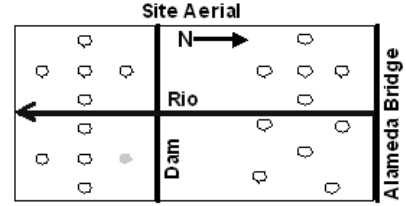

Diversion (ED10) West Well
 Statistics 9/22/2006-3/31/2007
 mean: 1520.95
 stdv: 0.16
 min: 1520.77
 max: 1521.45

Diversion (ED10) West Well
Water Table and River Gauge Height
 9/22/2006-3/31/2007: 15-Minute Data

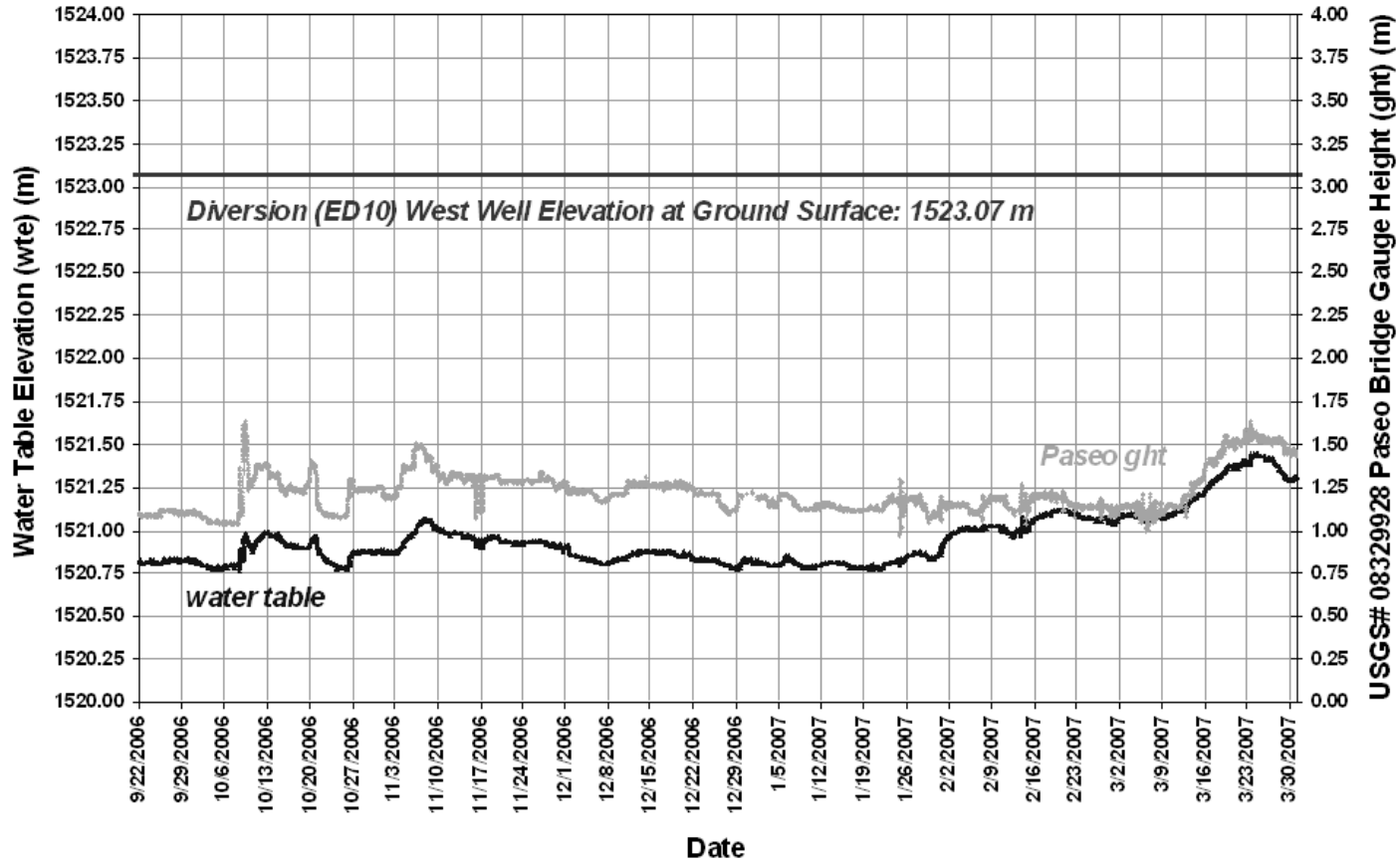
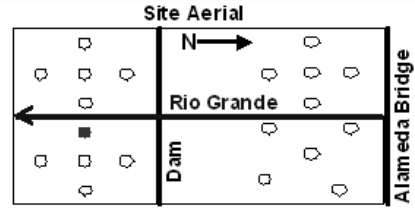

Diversion (ED10) East Well
 Statistics 9/22/2006-3/31/2007
 mean: 1520.13
 stdv: 0.16
 min: 1519.91
 max: 1520.58

Diversion (ED10) East Well
Water Table and River Gauge Height
 9/22/2006-3/31/2007: 15-Minute Data

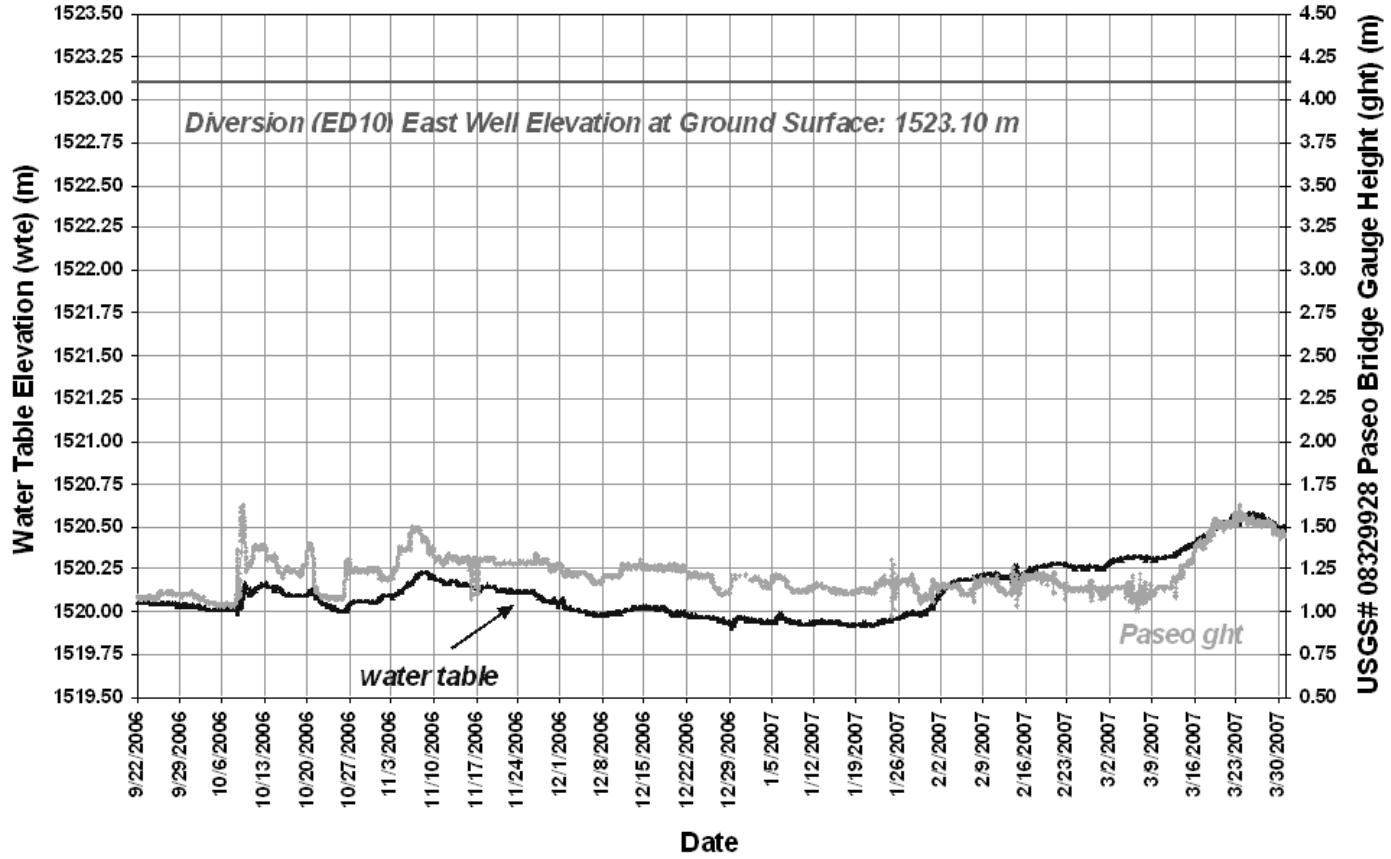
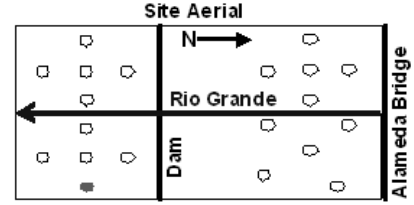

Diversion (ED10) Center Well wte (m)
 Statistics 9/22/2006-3/31/2007
 mean: 1520.48
 stdv: 0.17
 min: 1520.24
 max: 1520.98

**Diversion (ED10) Center Well
 Water Table and River Gauge Height
 9/22/2006-3/31/2007: 30-Minute Data**

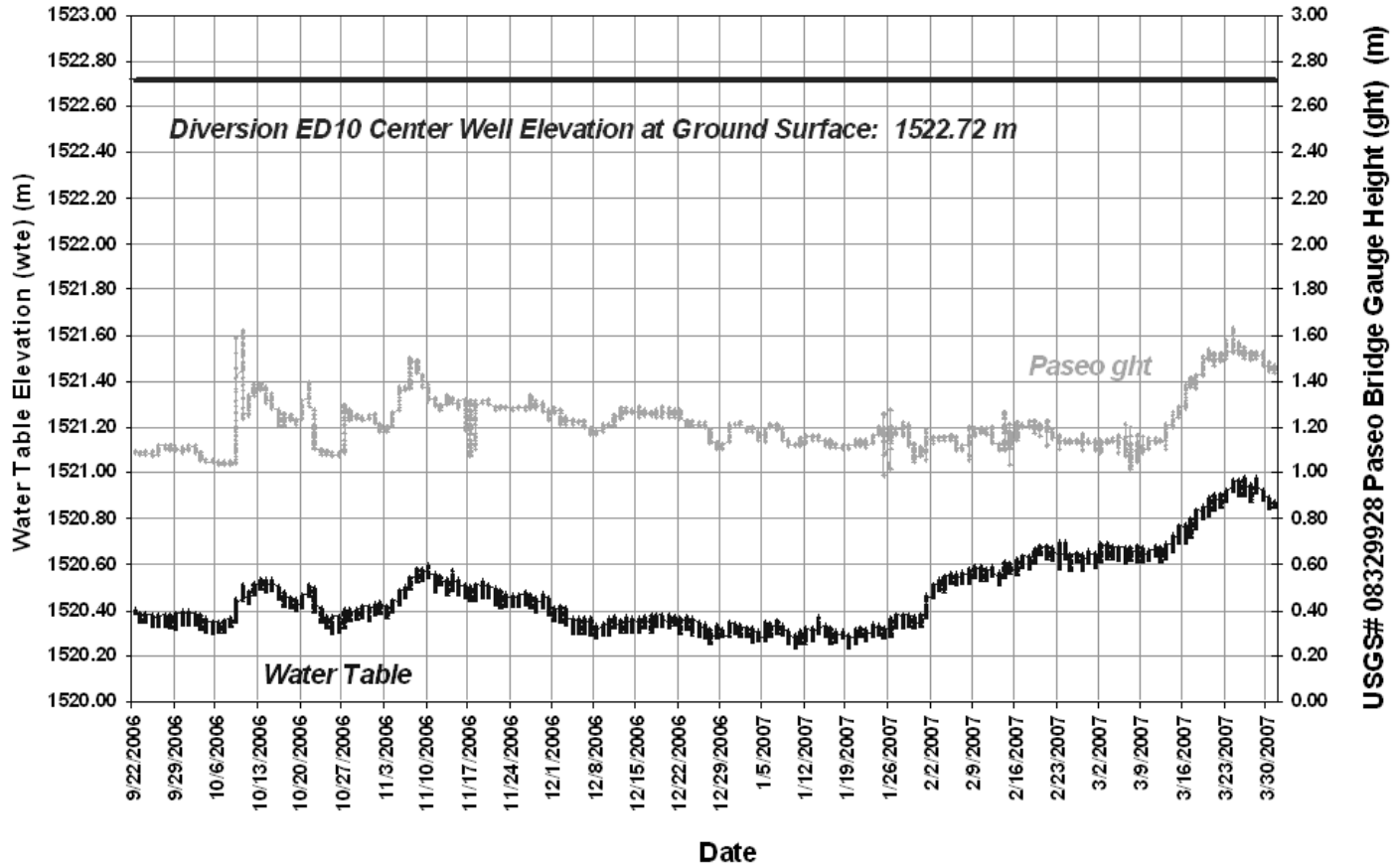
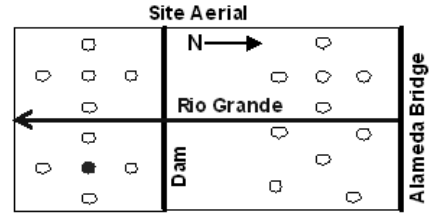

REPORT DOCUMENTATION PAGE

Form Approved
OMB No. 0704-0188

Public reporting burden for this collection of information is estimated to average 1 hour per response, including the time for reviewing instructions, searching existing data sources, gathering and maintaining the data needed, and completing and reviewing this collection of information. Send comments regarding this burden estimate or any other aspect of this collection of information, including suggestions for reducing this burden to Department of Defense, Washington Headquarters Services, Directorate for Information Operations and Reports (0704-0188), 1215 Jefferson Davis Highway, Suite 1204, Arlington, VA 22202-4302. Respondents should be aware that notwithstanding any other provision of law, no person shall be subject to any penalty for failing to comply with a collection of information if it does not display a currently valid OMB control number. **PLEASE DO NOT RETURN YOUR FORM TO THE ABOVE ADDRESS.**

1. REPORT DATE (DD-MM-YYYY) May 2011		2. REPORT TYPE Final report		3. DATES COVERED (From - To)	
4. TITLE AND SUBTITLE Investigating Groundwater/Surface Water Interaction at Diversion Dam Site: Report Documentary 2007-2008				5a. CONTRACT NUMBER	
				5b. GRANT NUMBER	
				5c. PROGRAM ELEMENT NUMBER	
6. AUTHOR(S) Julie Coonrod, Cliff Crawford, John Stormont, Christian LeJeune, and Isaiah Pedro				5d. PROJECT NUMBER	
				5e. TASK NUMBER	
				5f. WORK UNIT NUMBER	
7. PERFORMING ORGANIZATION NAME(S) AND ADDRESS(ES) University of New Mexico MSC01 1070 Civil Engineering Albuquerque, NM 87120				8. PERFORMING ORGANIZATION REPORT NUMBER ERDC/CHL CR-11-1	
9. SPONSORING / MONITORING AGENCY NAME(S) AND ADDRESS(ES) Coastal and Hydraulics Laboratory U.S. Army Engineer Research and Development Center 3909 Halls Ferry Road, Vicksburg, MS 39180-6199				10. SPONSOR/MONITOR'S ACRONYM(S)	
				11. SPONSOR/MONITOR'S REPORT NUMBER(S)	
12. DISTRIBUTION / AVAILABILITY STATEMENT Approved for public release; distribution is unlimited.					
13. SUPPLEMENTARY NOTES					
14. ABSTRACT This report concerns hydrological monitoring of groundwater wells installed with pressure transducers at four Bosque Ecosystem Monitoring Program (BEMP) sites, which bracket the Albuquerque Drinking Water Diversion Dam (DWD). The data obtained from these pressure transducers are coupled with river discharge and stage data from the U.S. Geological Survey's (USGS) river gauge 08329918 (at Alameda Bridge) located approximately 450 m north of the DWD, to provide a database for the purpose of estimating the interaction between groundwater and surface water, as well as the potential effects of the DWD in this urban stretch of the Rio Grande. Also included in this report is a description of the monitoring sites, the techniques used to install shallow groundwater wells and manage pressure transducers, and a presentation and analysis of groundwater data results from before, during, and after DWD construction, with a focus on the first year of baseline data covering the period of October 2006 through September 2007. This data are used to perform a variety of analyses, which assist in understanding how groundwater levels are influenced by river discharge, rain events, DWD trial operations, and soil properties. Key findings of this study indicate that soils within the study reach are conductive, with groundwater responding quickly to river stage changes. Groundwater levels are mainly a function of the boundary conditions (river and riverside drains), and become deeper towards the levees. Lateral hydraulic gradients are less than 1 percent between wells, with no major changes during the study period. Effects of DWD construction produced about a 9-month disruption in water tables mainly at the Diversion (ED10) site. Water tables then returned to preconstruction values.					
15. SUBJECT TERMS Albuquerque Diversion dam		Monitoring wells Phreatophytes Rio Grande		Riparian forest River diversion Shallow ground water	
16. SECURITY CLASSIFICATION OF:			17. LIMITATION OF ABSTRACT	18. NUMBER OF PAGES 376	19a. NAME OF RESPONSIBLE PERSON
a. REPORT UNCLASSIFIED	b. ABSTRACT UNCLASSIFIED	c. THIS PAGE UNCLASSIFIED			19b. TELEPHONE NUMBER (include area code)