

REPORT DOCUMENTATION PAGE			Form Approved OMB NO. 0704-0188		
<p>The public reporting burden for this collection of information is estimated to average 1 hour per response, including the time for reviewing instructions, searching existing data sources, gathering and maintaining the data needed, and completing and reviewing the collection of information. Send comments regarding this burden estimate or any other aspect of this collection of information, including suggestions for reducing this burden, to Washington Headquarters Services, Directorate for Information Operations and Reports, 1215 Jefferson Davis Highway, Suite 1204, Arlington VA, 22202-4302. Respondents should be aware that notwithstanding any other provision of law, no person shall be subject to any penalty for failing to comply with a collection of information if it does not display a currently valid OMB control number.</p> <p>PLEASE DO NOT RETURN YOUR FORM TO THE ABOVE ADDRESS.</p>					
1. REPORT DATE (DD-MM-YYYY) 18-02-2011		2. REPORT TYPE Final Report		3. DATES COVERED (From - To) 1-Jun-2006 - 28-Feb-2011	
4. TITLE AND SUBTITLE IPE Operations Field Effect Standard (Pressure Sensing Suit)			5a. CONTRACT NUMBER		
			5b. GRANT NUMBER W911NF-06-C-0040		
			5c. PROGRAM ELEMENT NUMBER 206023		
6. AUTHORS Mark Summers			5d. PROJECT NUMBER		
			5e. TASK NUMBER		
			5f. WORK UNIT NUMBER		
7. PERFORMING ORGANIZATION NAMES AND ADDRESSES Defense Science and Technology Laboratory Porton Down SP4 0JQ  00000 -			8. PERFORMING ORGANIZATION REPORT NUMBER		
9. SPONSORING/MONITORING AGENCY NAME(S) AND ADDRESS(ES) U.S. Army Research Office P.O. Box 12211 Research Triangle Park, NC 27709-2211			10. SPONSOR/MONITOR'S ACRONYM(S) ARO		
			11. SPONSOR/MONITOR'S REPORT NUMBER(S) 47174-CH-CDP.1		
12. DISTRIBUTION AVAILABILITY STATEMENT Approved for Public Release; Distribution Unlimited					
13. SUPPLEMENTARY NOTES The views, opinions and/or findings contained in this report are those of the author(s) and should not be construed as an official Department of the Army position, policy or decision, unless so designated by other documentation.					
14. ABSTRACT A prototype pressure sensing suit capability was developed successfully that allows real-time pressure data to be captured whilst performing activities in the field that cannot be readily simulated in the laboratory. Three military subjects were used to collect representative pressure data from a series of standard battlefield-type activities. The impact of terrain and wearing additional combat equipment was also investigated.					
15. SUBJECT TERMS pressure suit, pressure mapping, liquid protection					
16. SECURITY CLASSIFICATION OF:		17. LIMITATION OF ABSTRACT		15. NUMBER OF PAGES	19a. NAME OF RESPONSIBLE PERSON
a. REPORT UU	b. ABSTRACT UU	c. THIS PAGE UU	UU		Veronica Rapley
				19b. TELEPHONE NUMBER 441-980-6135	

## Report Title

IPE Operations Field Effect Standard (Pressure Sensing Suit)

### ABSTRACT

A prototype pressure sensing suit capability was developed successfully that allows real-time pressure data to be captured whilst performing activities in the field that cannot be readily simulated in the laboratory. Three military subjects were used to collect representative pressure data from a series of standard battlefield-type activities. The impact of terrain and wearing additional combat equipment was also investigated.

The data obtained from this study indicated that the mean pressures experienced at the elbows and knees ranged between 90 kPa to 160 kPa, whereas the remaining locations fell between 40 kPa and 60 kPa. Extremely high peak pressures were recorded up to 1379 kPa; however, generally these pressures were encountered for less than 2% over the duration of the exercise.

---

**List of papers submitted or published that acknowledge ARO support during this reporting period. List the papers, including journal references, in the following categories:**

**(a) Papers published in peer-reviewed journals (N/A for none)**

Number of Papers published in peer-reviewed journals: 0.00

---

**(b) Papers published in non-peer-reviewed journals or in conference proceedings (N/A for none)**

Number of Papers published in non peer-reviewed journals: 0.00

---

**(c) Presentations**

Number of Presentations: 0.00

---

**Non Peer-Reviewed Conference Proceeding publications (other than abstracts):**

Number of Non Peer-Reviewed Conference Proceeding publications (other than abstracts): 0

---

**Peer-Reviewed Conference Proceeding publications (other than abstracts):**

Number of Peer-Reviewed Conference Proceeding publications (other than abstracts): 0

---

**(d) Manuscripts**

Number of Manuscripts: 0.00

---

**Patents Submitted**

---

**Patents Awarded**

---

## Awards

---

### Graduate Students

<u>NAME</u>	<u>PERCENT SUPPORTED</u>
FTE Equivalent:	
Total Number:	

---

### Names of Post Doctorates

<u>NAME</u>	<u>PERCENT SUPPORTED</u>
FTE Equivalent:	
Total Number:	

---

### Names of Faculty Supported

<u>NAME</u>	<u>PERCENT SUPPORTED</u>
FTE Equivalent:	
Total Number:	

---

### Names of Under Graduate students supported

<u>NAME</u>	<u>PERCENT SUPPORTED</u>
FTE Equivalent:	
Total Number:	

---

### Student Metrics

This section only applies to graduating undergraduates supported by this agreement in this reporting period

The number of undergraduates funded by this agreement who graduated during this period: .....	0.00
The number of undergraduates funded by this agreement who graduated during this period with a degree in science, mathematics, engineering, or technology fields:.....	0.00
The number of undergraduates funded by your agreement who graduated during this period and will continue to pursue a graduate or Ph.D. degree in science, mathematics, engineering, or technology fields:.....	0.00
Number of graduating undergraduates who achieved a 3.5 GPA to 4.0 (4.0 max scale):.....	0.00
Number of graduating undergraduates funded by a DoD funded Center of Excellence grant for Education, Research and Engineering:.....	0.00
The number of undergraduates funded by your agreement who graduated during this period and intend to work for the Department of Defense .....	0.00
The number of undergraduates funded by your agreement who graduated during this period and will receive scholarships or fellowships for further studies in science, mathematics, engineering or technology fields: .....	0.00

---

### Names of Personnel receiving masters degrees

<u>NAME</u>
Total Number:

---

**Names of personnel receiving PhDs**

NAME

**Total Number:**

---

**Names of other research staff**

NAME

PERCENT SUPPORTED

**FTE Equivalent:**

**Total Number:**

---

**Sub Contractors (DD882)**

**Inventions (DD882)**

**Scientific Progress**

The reader is referred to the final technical report for a full description of the work carried out under this programme "See Attachment". The following information summarises the main scientific progress and accomplishments.

## Executive summary

This work was carried out under a 3 year US programme funded by the Defense Threat Reduction Agency (DTRA) (contract number W911 INF-06-C-0040).

## Aims

The overall aim of the programme was to develop a prototype pressure sensitive suit to map pressure and contact profiles experienced by CBRN protective clothing under field conditions.

The objective of the work reported here was to evaluate the prototype pressure suit and to collect pressure data from a series of battlefield-type activities.

## Military Relevance

Pressure data gained from the field trials will be used to validate/update clothing test regimes so that the liquid chemical agent performance of material swatches and full clothing systems is assessed using pressures representative of those experienced in the field. This will provide a clearer indication of the dermal protection offered by protective clothing and greatly enable risk management when using it. This information will also be used to inform the design requirements of future CBRN protective apparel.

## Work carried out

Three military subjects were used to collect representative pressure data from a series of standard battlefield-type activities. A number of variables were investigated that included: activity, subject mass terrain and the effect of wearing additional combat equipment.

## Conclusions

A pressure sensing suit capability has been developed to accurately map pressure and contact profiles experienced by CBRN protective clothing on the battlefield. The suit has been employed to capture real-time pressure data from a series of battlefield exercises that were designed in consultation with UK and US military officers.

Pressure data obtained from the field trials should be used for indication only. Pressures that fell outside the calibration range of the sensors were not recorded.

Typically, mean pressures at the elbows and knees ranged between 90 kPa to 160 kPa and the remaining locations across the body fell between 40 kPa and 60 kPa. Peak pressures at the elbows and knees were recorded up to 1379 kPa; however, generally these extremely high pressures were encountered for less than 2% over the duration of the exercise.

Performing the exercises whilst wearing the additional combat webbing and a back pack (weighing ~ 15 kg) had the biggest impact on the peak pressures recorded for the kneeling and assault exercises where average increases of 13% and 18% were observed respectively.

Sensors located at the knees and elbows suffered some damage during the trials. This was attributed to the high shear forces experienced. The damage, however, did not render the sensors completely ineffective, as pressure readings were still obtained for the active sensors.

A more complete understanding of the effects of pressure impaction on liquid penetration through clothing is required before changes in current swatch and full system clothing tests can be recommended.

## Proposed Future Work

Further carefully planned trials with a larger number of volunteers should be conducted in order to provide more statistically robust data.

If this capability is to be developed further, it is recommended that the sensors are made more robust. Alternatively, since it has

been shown that the pressures experienced at elbows and knees can be very high, the use of protective pads may be the only practical option for providing high levels of liquid protection at these locations. If this is the case, then sensors would no longer be required at the knees and elbows, but instead could be located at other additional positions. This would also have the advantage of preventing the pads having to be exchanged between different activities. It is also recommended that the dynamic range of the sensors be increased.

Man-in-simulant tests should be conducted to investigate the real impact on protection.

The extent of activities performed in the pressure suit should be extended to cover other specialist roles within the military.

Pressure data should be obtained for other types of terrain, for example desert, road, etc.

Additional functionality could be added to the system by including accelerometers to provide information on the dynamics of a subject's motion.

The use of protective pads at critical pressure points should be considered in future CBRN apparel design.

### **Technology Transfer**

**UNCLASSIFIED**

## **Pressure Sensing Suit**

MJ Summers

Dstl/TR53405  
February 2011

CA06PRO426

Dstl Porton Down  
Salisbury  
Wiltshire SP4 0JQ  
UK



**UNCLASSIFIED**

**Release Conditions**

This document has been prepared for DOD and, unless indicated, may be used and circulated in accordance with the conditions of the Order under which it was supplied.

It may not be used or copied for any non-Governmental or commercial purpose without the written agreement of DTRA.

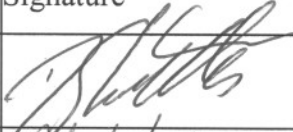
Defence Science and Technology Laboratory UK

Authorisation (Complete as applicable)			
	Name	Signature	Date
Group Leader	Mr. David Southgate		14-02-2011
Project Manager	Mrs. Tina Robinson-Collins		14/Feb/2011.
Technical Reviewer	Dr. Colin Willis		14/2/11

## Executive summary

This technical report describes work carried out under a 3 year US programme funded by the Defense Threat Reduction Agency (DTRA) (contract number W911 INF-06-C-0040).

### Aims

The overall aim of the programme was to develop a prototype pressure sensitive suit to map pressure and contact profiles experienced by CBRN protective clothing under field conditions.

The objective of the work reported here was to evaluate the prototype pressure suit and to collect pressure data from a series of battlefield-type activities.

### Military Relevance

Pressure data gained from the field trials will be used to validate/update clothing test regimes so that the liquid chemical agent performance of material swatches and full clothing systems is assessed using pressures representative of those experienced in the field. This will provide a clearer indication of the dermal protection offered by protective clothing and greatly enable risk management when using it. This information will also be used to inform the design requirements of future CBRN protective apparel

### Work carried out

Three military subjects were used to collect representative pressure data from a series of standard battlefield-type activities. A number of variables were investigated that included: activity, subject mass terrain and the effect of wearing additional combat equipment.

### Conclusions

- A pressure sensing suit capability has been developed to accurately map pressure and contact profiles experienced by CBRN protective clothing on the battlefield. The suit has been employed to capture real-time pressure data from a series of battlefield exercises that were designed in consultation with UK and US military officers.
- Pressure data obtained from the field trials should be used for indication only. Pressures that fell outside the calibration range of the sensors were not recorded.
- Typically, mean pressures at the elbows and knees ranged between 90 kPa to 160 kPa and the remaining locations across the body fell between 40 kPa and 60 kPa.
- Peak pressures at the elbows and knees were recorded up to 1379 kPa; however, generally these extremely high pressures were encountered for less than 2% over the duration of the exercise.

## UNCLASSIFIED

- Performing the exercises whilst wearing the additional combat webbing and a back pack (weighing ~ 15 kg) had the biggest impact on the peak pressures recorded for the kneeling and assault exercises where average increases of 13% and 18% were observed respectively.
- Sensors located at the knees and elbows suffered some damage during the trials. This was attributed to the high shear forces experienced. The damage, however, did not render the sensors completely ineffective, as pressure readings were still obtained for the active sensors.
- A more complete understanding of the effects of pressure impaction on liquid penetration through clothing is required before changes in current swatch and full system clothing tests can be recommended.

### **Future Programme Directions**

- Further carefully planned trials with a larger number of volunteers should be conducted in order to provide more statistically robust data.
- If this capability is to be developed further, it is recommended that the sensors are made more robust. Alternatively, since it has been shown that the pressures experienced at elbows and knees can be very high, the use of protective pads may be the only practical option for providing high levels of liquid protection at these locations. If this is the case, then sensors would no longer be required at the knees and elbows, but instead could be located at other additional positions. This would also have the advantage of preventing the pads having to be exchanged between different activities. It is also recommended that the dynamic range of the sensors be increased.
- Man-in-simulant tests should be conducted to investigate the real impact on protection.
- The extent of activities performed in the pressure suit should be extended to cover other specialist roles within the military.
- Pressure data should be obtained for other types of terrain, for example desert, road, etc.
- Additional functionality could be added to the system by including accelerometers to provide information on the dynamics of a subject's motion.
- The use of protective pads at critical pressure points should be considered in future CBRN apparel design.

## Results Table of contents

<b>Executive summary</b>	<b>1</b>
<b>List of figures</b>	<b>5</b>
<b>List of tables</b>	<b>11</b>
<b>1 Introduction</b>	<b>14</b>
<b>2 Prototype Pressure Sensitive Suit System</b>	<b>15</b>
<b>2.1 Pressure mapping technology</b>	<b>15</b>
<b>2.2 Carriage system</b>	<b>16</b>
<b>2.3 Integration into a CBR garment</b>	<b>18</b>
<b>2.4 WiFi Network</b>	<b>19</b>
<b>2.5 Software</b>	<b>20</b>
<b>3 Field Trial</b>	<b>23</b>
<b>3.1 Kneeling</b>	<b>23</b>
<b>3.2 Assault</b>	<b>24</b>
<b>3.3 Leopard Crawl</b>	<b>25</b>
<b>3.4 Subjects</b>	<b>25</b>
<b>3.5 Field trial variables</b>	<b>26</b>
<b>3.6 Pressure sensor configuration</b>	<b>26</b>
<b>4 Data Presentation</b>	<b>29</b>
<b>5 Results</b>	<b>31</b>
<b>5.1 Kneeling</b>	<b>31</b>
<b>5.2 Assault</b>	<b>56</b>
<b>5.3 Leopard Crawl</b>	<b>81</b>
<b>6 Discussion</b>	<b>101</b>
<b>7 Conclusions</b>	<b>104</b>

<b>8</b>	<b>Future Programme Directions</b>	<b>105</b>
<b>9</b>	<b>List of references</b>	<b>106</b>
<b>10</b>	<b>Appendix A: Sensor specifications</b>	<b>107</b>
<b>11</b>	<b>Appendix B: Suit design drawings</b>	<b>111</b>
<b>11.1</b>	<b>XSENSOR pad configurations</b>	<b>111</b>
<b>12</b>	<b>Appendix C: Peak pressure distributions</b>	<b>115</b>
<b>12.1</b>	<b>Assault</b>	<b>115</b>
<b>12.2</b>	<b>Leopard Crawl</b>	<b>123</b>
	<b>Initial distribution</b>	<b>131</b>
	<b>Report Documentation Form</b>	<b>133</b>

## List of figures

<b>Figure 1 – Prototype pressure sensing suit system</b>	<b>15</b>
<b>Figure 2 – Schematic of the electronic hardware</b>	<b>16</b>
<b>Figure 3 – Panasonic Toughbook CF-U1</b>	<b>16</b>
<b>Figure 4 – Bespoke carriage system</b>	<b>17</b>
<b>Figure 5 – CAD image of the cradles designed to secure X3 electronics</b>	<b>17</b>
<b>Figure 6 – CAD image of the USB A connector</b>	<b>18</b>
<b>Figure 7 – Schematic of modified MkIVa CBR garment</b>	<b>18</b>
<b>Figure 8 –Carriage loading options: beneath and outside the suit.</b>	<b>19</b>
<b>Figure 9 – Cisco AP 541N Wireless Access Point</b>	<b>20</b>
<b>Figure 10 – Test definition window</b>	<b>20</b>
<b>Figure 11 – Live display window used to monitor real-time pressures</b>	<b>21</b>
<b>Figure 12 – Synchronised video and data</b>	<b>22</b>
<b>Figure 13 – Taking aim during a kneeling exercise</b>	<b>23</b>
<b>Figure 14 – Relaxed kneeling position</b>	<b>23</b>
<b>Figure 15 – Taking cover during an assault</b>	<b>24</b>
<b>Figure 16 – Prone position taking aim during an assault</b>	<b>24</b>
<b>Figure 17 – Hip re-load during an assault</b>	<b>24</b>
<b>Figure 18 – Standing recovery after performing an assault</b>	<b>25</b>
<b>Figure 19 – Leopard crawl</b>	<b>25</b>
<b>Figure 20 – Suit configuration 1 used to assess ‘kneeling’ and the ‘leopard crawl’</b>	<b>27</b>
<b>Figure 21 – Suit configuration 2 used to assess the ‘assault’ only</b>	<b>27</b>
<b>Figure 22 – Suit configuration 3 used to assess ‘kneeling’, the ‘assault’ and the ‘leopard crawl’</b>	<b>28</b>
<b>Figure 23 – Suit configuration 4 used to assess the ‘assault’ only</b>	<b>28</b>

<b>Figure 24 – Pressure data for a given location taken at time ‘t’ during an exercise</b>	<b>29</b>
<b>Figure 25 – Mean pressures calculated for the kneeling exercise performed on grassland by Subject A.</b>	<b>31</b>
<b>Figure 26 – Peak pressures recorded for the kneeling exercise performed on grassland by Subject A.</b>	<b>33</b>
<b>Figure 27 – Peak pressure distribution recorded for right knee during the kneeling exercise performed on grassland by Subject A.</b>	<b>35</b>
<b>Figure 28 – Mean pressures calculated for the kneeling exercise performed inside the laboratory by Subject A.</b>	<b>36</b>
<b>Figure 29 – Peak pressures recorded for the kneeling exercise performed inside the laboratory by Subject A.</b>	<b>38</b>
<b>Figure 30 – Peak pressure distribution recorded for the right knee during the kneeling exercise performed in the laboratory by Subject A.</b>	<b>40</b>
<b>Figure 31 – Mean pressures calculated for the kneeling exercise performed on grassland by Subject B.</b>	<b>41</b>
<b>Figure 32 – Peak pressure distribution recorded for the kneeling exercise performed on grassland with additional kit by Subject B.</b>	<b>43</b>
<b>Figure 33 – Peak pressure distribution recorded for the right knee during the kneeling exercise performed on grassland by Subject B.</b>	<b>45</b>
<b>Figure 34 – Mean pressures calculated for the kneeling exercise performed inside the laboratory by Subject B.</b>	<b>46</b>
<b>Figure 35 – Peak pressures recorded for the kneeling exercise performed in the laboratory by volunteer B.</b>	<b>48</b>
<b>Figure 36 – Peak pressure distribution recorded for the right knee during the kneeling exercise performed in the laboratory by Subject B.</b>	<b>50</b>
<b>Figure 37 – Mean pressures calculated for the kneeling exercise performed inside the laboratory by Subject C.</b>	<b>51</b>
<b>Figure 38 – Peak pressures recorded for the kneeling exercise performed inside the laboratory by Subject C.</b>	<b>53</b>
<b>Figure 39 – Peak pressure distribution recorded for the right knee during the kneeling exercise performed in the laboratory by Subject C.</b>	<b>55</b>
<b>Figure 40 – Mean pressures obtained for the assault exercise performed on grassland by Subject A.</b>	<b>56</b>

<b>Figure 41 – Peak pressures recorded for the assault exercise performed on grassland by Subject A.</b>	<b>58</b>
<b>Figure 42 – Peak pressure distribution recorded for the right elbow during the assault exercise performed on grassland by Subject A.</b>	<b>60</b>
<b>Figure 43 – Mean pressures obtained for the assault exercise performed in the laboratory by Subject A.</b>	<b>61</b>
<b>Figure 44 – Peak pressures recorded for the assault exercise performed in the laboratory by Subject A.</b>	<b>63</b>
<b>Figure 45 – Peak pressure distribution recorded for the right elbow during the assault exercise performed in the laboratory by Subject A.</b>	<b>65</b>
<b>Figure 46 – Mean pressures obtained for the assault exercise performed on grassland by Subject B.</b>	<b>66</b>
<b>Figure 47 – Maximum pressures recorded for the assault exercise performed on grassland by Subject B.</b>	<b>68</b>
<b>Figure 48 – Peak pressure distribution recorded for the right elbow during the assault exercise performed on grassland by Subject B.</b>	<b>70</b>
<b>Figure 49 – Mean pressures obtained for the assault exercise performed in the laboratory by Subject B.</b>	<b>71</b>
<b>Figure 50 – Peak pressures recorded for the assault exercise performed in the laboratory by Subject B.</b>	<b>73</b>
<b>Figure 51 – Peak pressure distribution recorded for the right elbow during the assault exercise performed in the laboratory by Subject B.</b>	<b>75</b>
<b>Figure 52 – Mean pressures obtained for the assault exercise performed in the laboratory by Subject C.</b>	<b>76</b>
<b>Figure 53 – Peak pressures recorded for the assault exercise performed in the laboratory by Subject C.</b>	<b>78</b>
<b>Figure 54 – Peak pressure distribution recorded for the right elbow during the assault exercise performed in the laboratory by Subject C.</b>	<b>80</b>
<b>Figure 55 – Mean pressures obtained for the leopard crawl performed on grassland by Subject A.</b>	<b>81</b>
<b>Figure 56 – Peak pressures obtained for the leopard crawl performed on grassland by Subject A.</b>	<b>83</b>
<b>Figure 57 – Peak pressure distribution recorded for the right knee during the leopard crawl performed on grassland by Subject A.</b>	<b>85</b>

<b>Figure 58 – Mean pressures obtained for the leopard crawl performed in the laboratory by Subject A.</b>	<b>86</b>
<b>Figure 59 – Peak pressures obtained for the leopard crawl performed in the laboratory by Subject A.</b>	<b>88</b>
<b>Figure 60 – Peak pressure distribution recorded for the right knee during the leopard crawl performed in the laboratory by Subject A.</b>	<b>90</b>
<b>Figure 61 – Mean pressures obtained for the leopard crawl performed on grassland by Subject B.</b>	<b>91</b>
<b>Figure 62 – Peak pressures obtained for the leopard crawl performed on grassland by Subject B.</b>	<b>93</b>
<b>Figure 63 – Peak pressure distribution recorded for the right elbow during the leopard crawl performed on grassland by Subject B.</b>	<b>95</b>
<b>Figure 64 – Mean pressures obtained for the leopard crawl performed in the laboratory by Subject C.</b>	<b>96</b>
<b>Figure 65 – Peak pressures obtained for the leopard crawl performed in the laboratory by Subject C.</b>	<b>98</b>
<b>Figure 66 – Peak pressure distribution recorded for the right elbow during the leopard crawl performed on grassland by Subject C.</b>	<b>100</b>
<b>Figure 67 – Peak pressure distribution recorded for the left elbow during the assault exercise performed on grassland by Subject A.</b>	<b>115</b>
<b>Figure 68 – Peak pressure distribution recorded for the left elbow during the assault exercise performed in the laboratory by Subject A.</b>	<b>116</b>
<b>Figure 69 – Peak pressure distribution recorded for the left knee during the assault exercise performed on grassland by Subject A.</b>	<b>116</b>
<b>Figure 70 – Peak pressure distribution recorded for the left knee during the assault exercise performed in the laboratory by Subject A.</b>	<b>117</b>
<b>Figure 71 – Peak pressure distribution recorded for the right knee during the assault exercise performed on grassland by Subject A.</b>	<b>117</b>
<b>Figure 72 – Peak pressure distribution recorded for the right knee during the assault exercise performed in the laboratory by Subject A.</b>	<b>118</b>
<b>Figure 73 – Peak pressure distribution recorded for the left elbow during the assault exercise performed on grassland by Subject B.</b>	<b>118</b>
<b>Figure 74 - Peak pressure distribution recorded for the left elbow during the assault exercise performed in the laboratory by Subject B.</b>	<b>119</b>

<b>Figure 75 – Peak pressure distribution recorded for the left knee during the assault exercise performed on grassland by Subject B.</b>	<b>119</b>
<b>Figure 76 – Peak pressure distribution recorded for the left knee during the assault exercise performed in the laboratory by Subject B.</b>	<b>120</b>
<b>Figure 77 – Peak pressure distribution recorded for the right knee during the assault exercise performed on grassland by Subject B.</b>	<b>120</b>
<b>Figure 78 – Peak pressure distribution recorded for the right knee during the assault exercise performed in the laboratory by Subject B.</b>	<b>121</b>
<b>Figure 79 – Peak pressure distribution recorded for the left elbow during the assault exercise performed in the laboratory by Subject C.</b>	<b>121</b>
<b>Figure 80 – Peak pressure distribution recorded for the left knee during the assault exercise performed in the laboratory by Subject C.</b>	<b>122</b>
<b>Figure 81 - Peak pressure distribution recorded for the right knee during the assault exercise performed in the laboratory by Subject C.</b>	<b>122</b>
<b>Figure 82 – Peak pressure distribution recorded for the left elbow during the leopard crawl performed on grassland by Subject A.</b>	<b>123</b>
<b>Figure 83 – Peak pressure distribution recorded for the left elbow during the leopard crawl performed in the laboratory by Subject A.</b>	<b>124</b>
<b>Figure 84 – Peak pressure distribution recorded for the right elbow during the leopard crawl performed on grassland by Subject A.</b>	<b>124</b>
<b>Figure 85 – Peak pressure distribution recorded for the right elbow during the leopard crawl performed in the laboratory by Subject A.</b>	<b>125</b>
<b>Figure 86 – Peak pressure distribution recorded for the left knee during the leopard crawl performed on grassland by Subject A.</b>	<b>125</b>
<b>Figure 87 – Peak pressure distribution recorded for the left knee during the leopard crawl performed in the laboratory by Subject A.</b>	<b>126</b>
<b>Figure 88 – Peak pressure distribution recorded for the left elbow during the leopard crawl performed on grassland by Subject B.</b>	<b>126</b>
<b>Figure 89 – Peak pressure distribution recorded for the left knee during the leopard crawl performed on grassland by Subject B.</b>	<b>127</b>
<b>Figure 90 - Peak pressure distribution recorded for the right knee during the leopard crawl performed on grassland by Subject B.</b>	<b>127</b>
<b>Figure 91 – Peak pressure distribution recorded for the left elbow during the leopard crawl performed in the laboratory by Subject C.</b>	<b>128</b>

**Figure 92 – Peak pressure distribution recorded for the left knee during the leopard crawl performed in the laboratory by Subject C. 128**

**Figure 93 – Peak pressure distribution recorded for the right knee during the leopard crawl performed in the laboratory by Subject C. 129**

## List of tables

<b>Table 1 – Subject information</b>	<b>26</b>
<b>Table 2 – Mean pressures, and standard deviations of the mean (SD), calculated for the kneeling exercise performed on grassland by Subject A.</b>	<b>32</b>
<b>Table 3 – Peak pressures recorded for kneeling performed on grassland by Subject A.</b>	<b>34</b>
<b>Table 4 – Mean pressures, and standard deviations of the mean (SD), calculated for kneeling performed in the laboratory by Subject A.</b>	<b>37</b>
<b>Table 5 – Peak pressures recorded for kneeling performed in the laboratory by Subject A.</b>	<b>39</b>
<b>Table 6 – Mean pressures, and standard deviations of the mean (SD), calculated for kneeling performed on grassland by Subject B.</b>	<b>42</b>
<b>Table 7 – Peak pressures recorded for kneeling performed on grassland by Subject B.</b>	<b>44</b>
<b>Table 8 – Mean pressures, and standard deviations of the mean (SD), calculated for kneeling performed in the laboratory by Subject B.</b>	<b>47</b>
<b>Table 9 – Peak pressures recorded for kneeling performed in the laboratory by Subject B.</b>	<b>49</b>
<b>Table 10 – Mean pressures, and standard deviations of the mean (SD), calculated for kneeling performed in the laboratory by Subject C.</b>	<b>52</b>
<b>Table 11 – Peak pressures recorded for kneeling performed in the laboratory by Subject C.</b>	<b>54</b>
<b>Table 12 – Mean pressures, and standard deviations of the mean (SD), calculated for the assault exercise performed on grassland by Subject A.</b>	<b>57</b>
<b>Table 13 – Peak pressures recorded for the assault exercise performed on grassland by Subject A.</b>	<b>59</b>
<b>Table 14 – Mean pressures, and standard deviations of the mean (SD), calculated for the assault exercise performed in the laboratory by Subject A.</b>	<b>62</b>
<b>Table 15 – Peak pressures recorded for the assault exercise performed in the laboratory by Subject A.</b>	<b>64</b>
<b>Table 16 – Mean pressures, and standard deviations of the mean (SD), calculated for the assault exercise performed on grassland by Subject B.</b>	<b>67</b>
<b>Table 17 – Peak pressures recorded for the assault exercise performed on grassland by Subject B.</b>	<b>69</b>

<b>Table 18 – Mean pressures, and associated standard deviations (SD) obtained for the assault exercise performed in the laboratory by Subject B.</b>	<b>72</b>
<b>Table 19 – Peak pressures recorded for the assault exercise performed in the laboratory by Subject B.</b>	<b>74</b>
<b>Table 20 – Mean pressures, and associated standard deviations (SD) obtained for the assault exercise performed in the laboratory by Subject C.</b>	<b>77</b>
<b>Table 21 – Peak pressures recorded for the assault exercise performed in the laboratory by Subject C.</b>	<b>79</b>
<b>Table 22 – Mean pressure, and associated standard deviations (SD) for the leopard crawl performed on grassland by Subject A.</b>	<b>82</b>
<b>Table 23 – Peak pressures recorded for the leopard crawl performed on grassland by Subject A.</b>	<b>84</b>
<b>Table 24 – Mean pressures, and associated standard deviations (SD) for the leopard crawl performed in the laboratory by Subject A.</b>	<b>87</b>
<b>Table 25 – Peak pressures recorded for the leopard crawl performed in the laboratory by Subject A.</b>	<b>89</b>
<b>Table 26 – Mean pressures, and associated standard deviations (SD), obtained for the leopard crawl performed on grassland by Subject B.</b>	<b>92</b>
<b>Table 27 – Peak pressures recorded for the leopard crawl performed on grassland by Subject B.</b>	<b>94</b>
<b>Table 28 – Mean pressures, and associated standard deviations (SD), obtained for the leopard crawl performed in the laboratory by Subject C.</b>	<b>97</b>
<b>Table 29 – Peak pressures recorded for the leopard crawl performed in the laboratory by Subject C.</b>	<b>99</b>
<b>Table 30 – Summary of the average pressure changes resulting from the additional kit load</b>	<b>102</b>

**UNCLASSIFIED**

INTENTIONALLY LEFT BLANK

## 1 Introduction

This report summarises the work carried out under a three year US programme funded by the Defense Threat Reduction Agency (DTRA). The ultimate aim of this programme was to develop a prototype pressure sensitive suit to accurately map pressure and contact profiles across a CBRN protective garment during a set of standard battlefield-type activities.

Pressure data gained from the field trials will be used to validate/update clothing test regimes so that the liquid chemical agent performance of material swatches and full clothing systems is assessed using pressures representative of those experienced in the field. This will provide a clearer indication of the dermal protection offered by protective clothing and greatly enable risk management when using it. This information will also be used to inform the design requirements of future CBRN protective apparel.

This final report is broken down into different sections that describe the following:

- Section 2 provides an overview of the prototype pressure sensing suit system and its components.
- Section 3 describes the exercises performed during the field trial.
- Section 4 defines the way in which the data from the trials have been represented.
- Section 5 describes the results of the field trials.
- Section 6 discusses the results from the field trials.
- Section 7 draws conclusions from the programme.
- Section 8 presents recommendations for future work.

## 2 Prototype Pressure Sensitive Suit System

A prototype pressure sensing suit capability has been developed that allows real-time pressure data to be captured whilst carrying out realistic battlefield activities that cannot be readily simulated inside a laboratory.

The prototype system is displayed in Figure 1 and its components and software are described in detail in Sections 2.1 to 2.5.

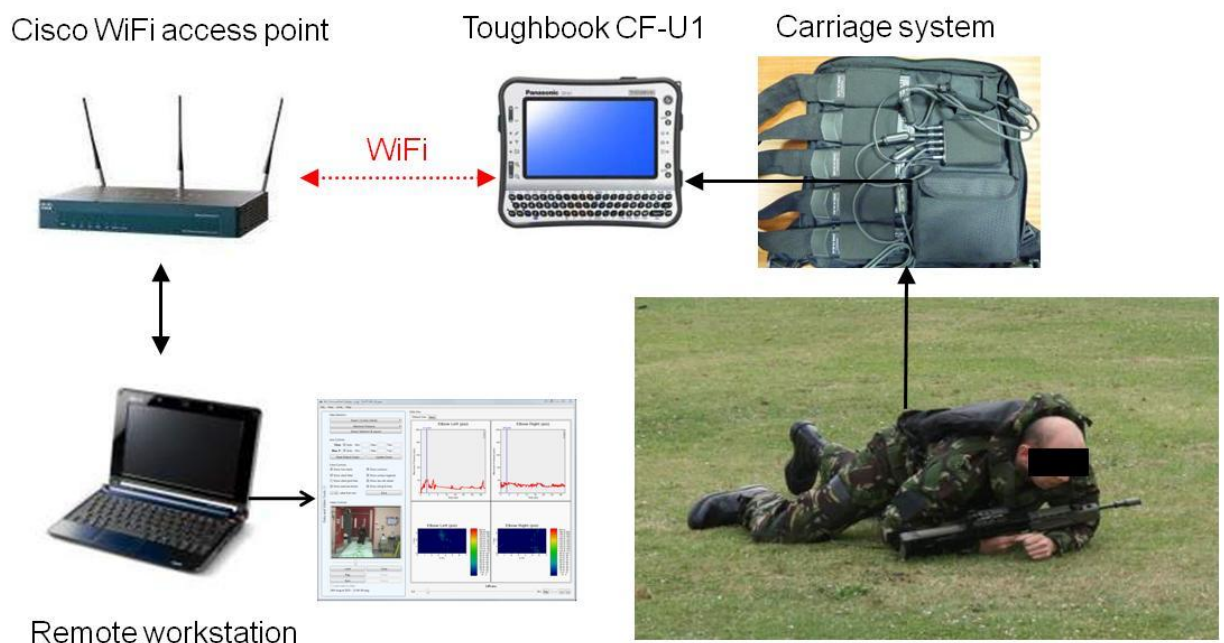

Figure 1 – Prototype pressure sensing suit system

### 2.1 Pressure mapping technology

The XSENSOR pressure mapping technology was down-selected based upon its performance over alternative pressure mapping technologies [1-4]. The sensors were pre-calibrated over two pressure ranges: 34.5 kPa to 344.7 kPa (i.e. 5 psi to 50 psi) and 68.9 kPa to 1379 kPa (i.e. 10 psi to 200 psi). The sensor specifications are provided in Appendix A. XSENSOR developed a Dynamic Link Library (DLL) to allow remote control and monitoring of the sensor pads through a bespoke software package (Section 2.5).

The pressure mapping system was designed and manufactured to include five pairs of split sensors. Each sensor pair connects to a single sensor pack (SPK) and the sensor packs connect to a data logging device *via* an X3 Pro hub and X3 node, as illustrated in

Figure 2. The mobile data logging device then stores and transmits data wirelessly to a remote workstation to allow the trial to be monitored in real-time.

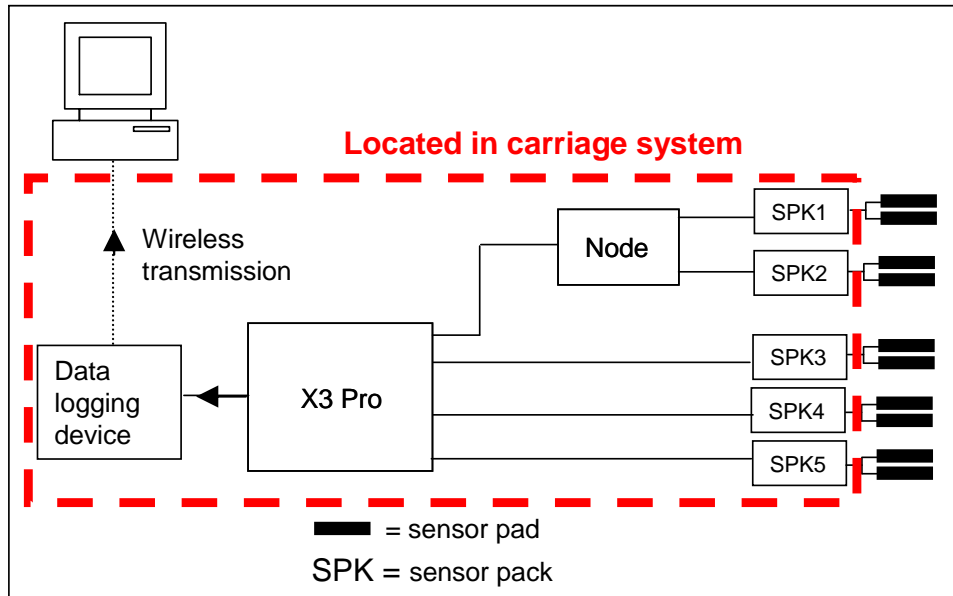

Figure 2 – Schematic of the electronic hardware

A number of mobile data logging devices were investigated, but the Panasonic Toughbook CF-U1 (Figure 3) was chosen as it provided the most confidence in its performance. The reader is referred to Reference 5 for the review of candidate devices carried out under this programme.



Figure 3 – Panasonic Toughbook CF-U1

## 2.2 Carriage system

A bespoke carriage system was designed and manufactured to house the associated sensor electronics, sensor cabling and Panasonic Toughbook CF-U1 (Figure 4).

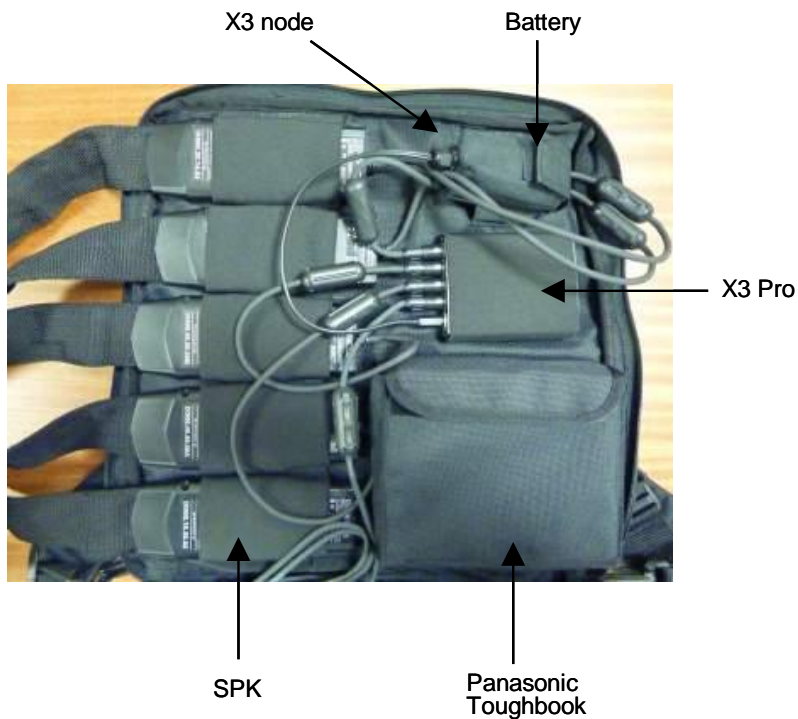

Figure 4 – Bespoke carriage system

Connectivity of the X3 electronics was a potential a vulnerability and therefore secure sheaths were designed using Dstl’s CAD and rapid prototyping facility (Figure 5). The USB connection from the X3 Pro electronics to the Panasonic Toughbook CF-U1 was another vulnerability with potential to cause technical problems when conducting a trial. The Toughbook CF-U1 had a ‘screw in’ USB A port, therefore a support was designed to clamp around the USB A connector and securely screw it into the Toughbook CF-U1 (Figure 6).

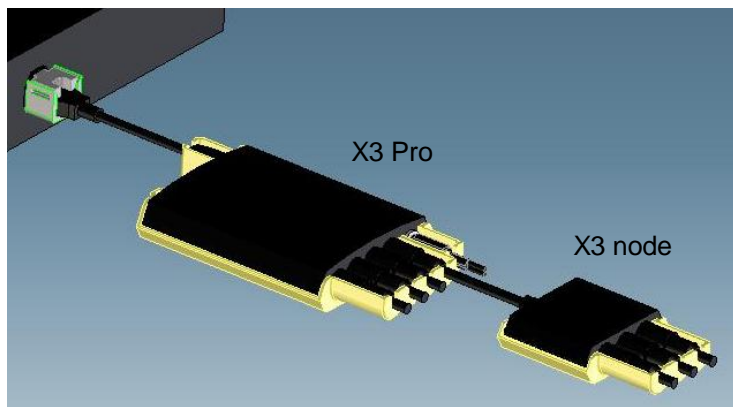

Figure 5 – CAD image of the cradles designed to secure X3 electronics

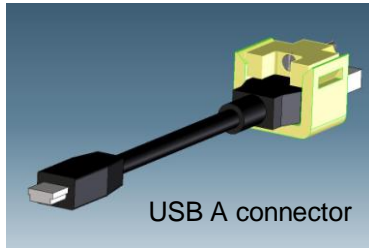

Figure 6 – CAD image of the USB A connector

### 2.3 Integration into a CBR garment

Smart Garment People Ltd. (an independent clothing design house) was used to modify a UK CBR garment (the MkIVa) to include sensor pockets at target locations. The sensor location was dependent upon the type of activity being assessed and the dress-state of the subject; therefore in consultation with both UK and US military officers, primary target locations were identified as: knees, elbows, forearms, shoulders and hips. However, to maximise body coverage, the garment was designed to include additional sensor pockets, as shown in Figure 7. The design drawings used to modify the garment are included in Appendix B.

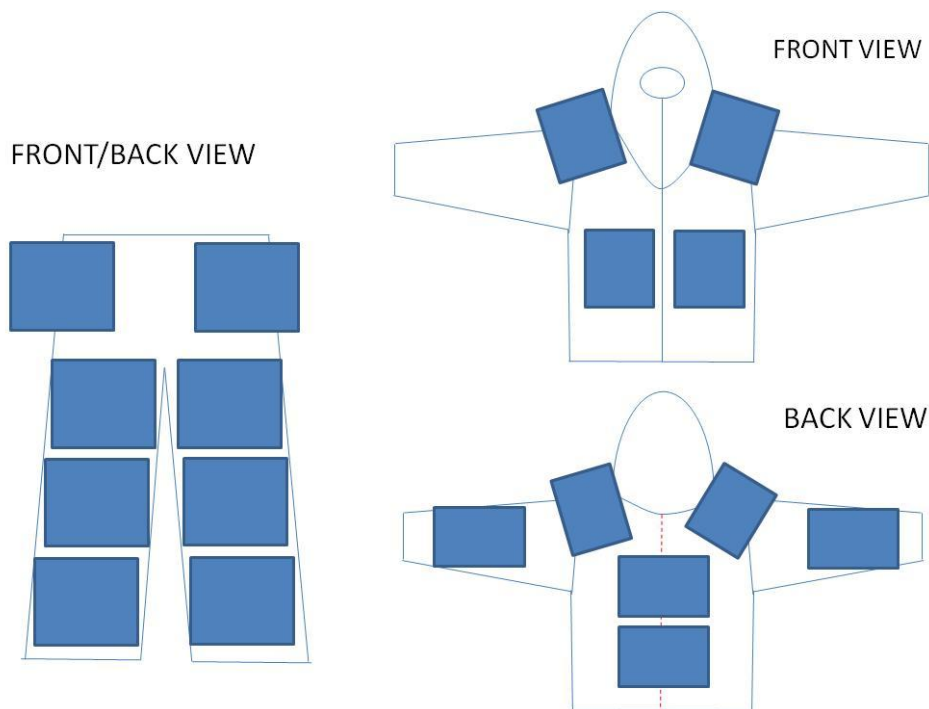

Figure 7 – Schematic of modified MkIVa CBR garment

The modified CBR ensemble was designed to allow the carriage system to be worn either underneath or over the top of the jacket, as shown in Figure 8.



Figure 8 –Carriage loading options: beneath and outside the suit.

## 2.4 WiFi Network

In terms of networking, the Panasonic Toughbook CF-U1 supports IEEE 802.11a/b/g/draft-n. “Draft-n” WiFi claims typical maximum throughput of over 5 MBytes/s. These rates can, however, be affected by a number of factors, including radio interference and obstacles between the transmitter and receiver.

Nominal maximum outdoor range is approximately 100 m; this figure is also affected by interference and obstacles. The aerial size of the remote device is also a factor. Placing the Toughbook CF-U1 within a backpack worn by the subject has the potential to decrease the range and strength of the signal. Therefore a WiFi network was constructed using a Cisco AP 541N dual band (2.4-GHz or 5-GHz) WiFi access point to increase the radio reception (Figure 9). The access point is intended to be situated in the centre of the testing area and connected to the monitoring station by a wired or wireless link. This also provides the option to add secondary access points to extend the wireless coverage if required.



Figure 9 – Cisco AP 541N Wireless Access Point

## 2.5 Software

A software package was developed by Mathshop, an independent software house, which consists of 3 separate modules:

### 2.5.1 Recording module

The recording module interacts with the XSENSOR system through an interface dynamic link module (DLL) to capture (at a specified rate or as frequently as possible) the pressure values for each cell of the pads being monitored. The recording module provides the user with the ability to define, save and reload test configurations and exercise sequences, as shown in Figure 10.

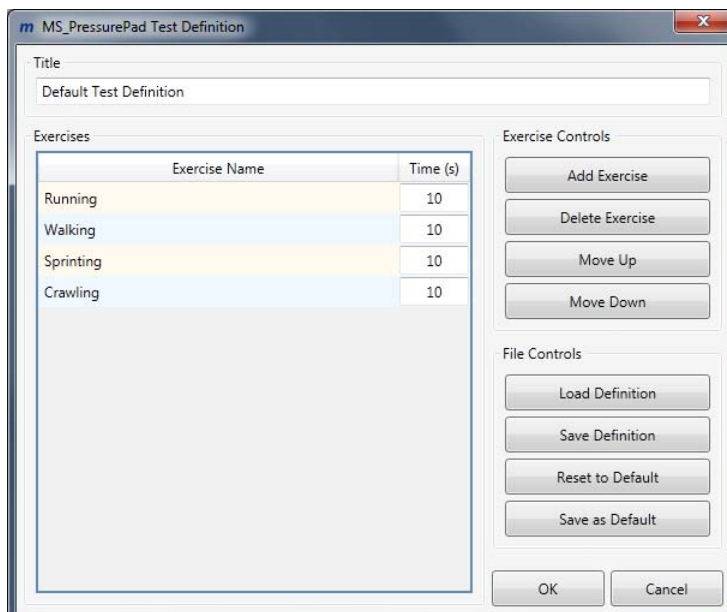

Figure 10 – Test definition window

### 2.5.2 Remote control and monitoring module

The remote control and monitoring module interacts with the recording module to monitor and manage the trial. This provides the remote user with the ability to initiate, suspend and end recording, and to designate the beginning and end of exercises. It also contains a live display that allows the user to monitor a trial in real-time (Figure 11).

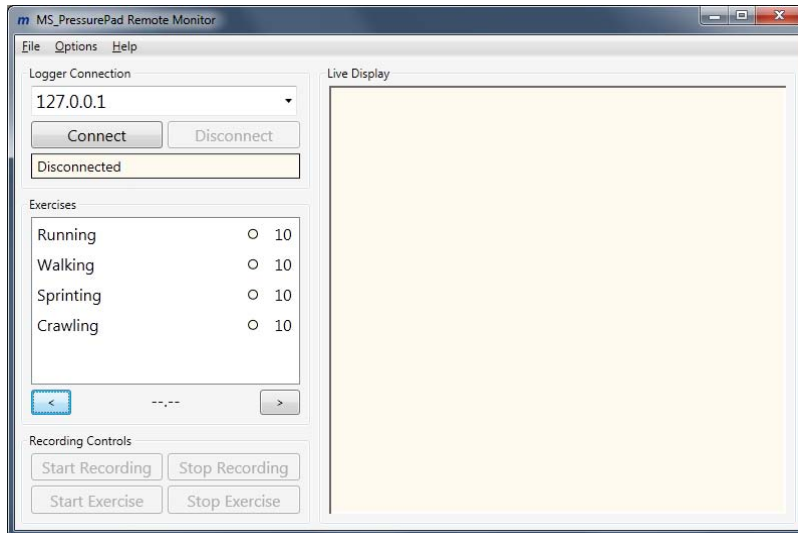

Figure 11 – Live display window used to monitor real-time pressures

### 2.5.3 Analysis module

The analysis module provides the user with data analysis, presentation and export facilities. This module enables the user to:

- view average pressure, peak pressure and integrated pressure (i.e. total load) for each sensor pad as a function of time
- locate data by exercise
- display data for each pad as pressure contours
- synchronise a moving cursor on the charts with the contour display and video
- export the results to Excel files and to .csv files

Figure 12 displays a screen shot of the analysis window taken from a preliminary laboratory trial.

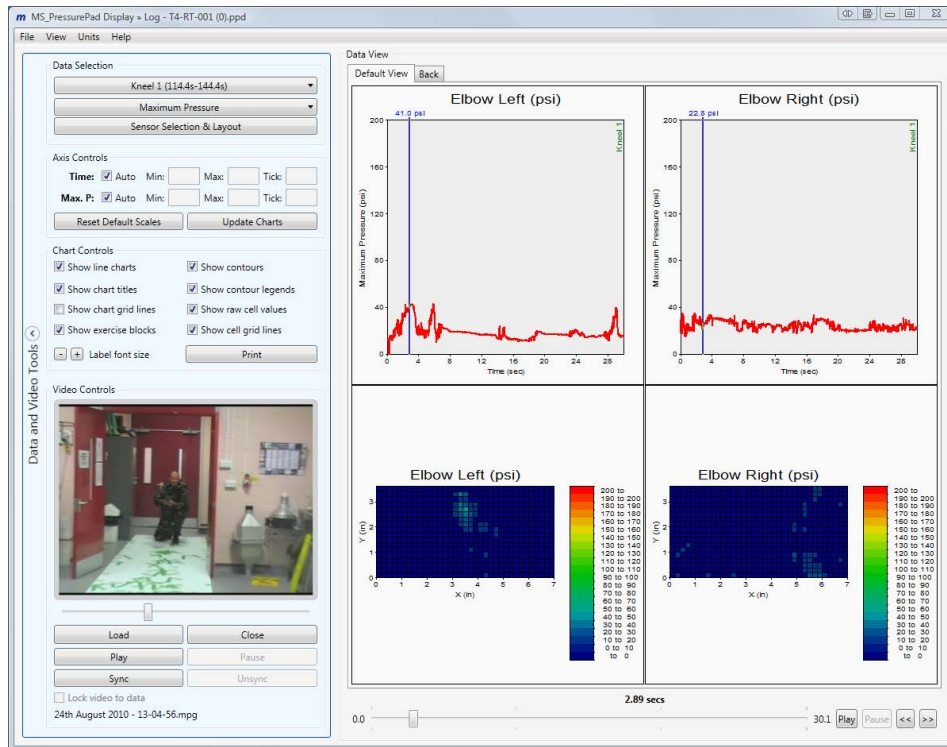

Figure 12 – Synchronised video and data

### 3 Field Trial

A series of exercises designed to mimic standard battlefield-type activities was constructed based upon advice from both UK and US military personnel.

The exercises included:

#### 3.1 Kneeling

The subject would walk a short distance, as if on patrol, and then take cover to the kneeling position whilst taking aim with their rifle, as shown in Figure 13.



Figure 13 – Taking aim during a kneeling exercise

The subject would then take up a more relaxed kneeling position by repositioning their body weight on to the back of the heel of the kneeling leg, as shown in Figure 14, before standing.



Figure 14 – Relaxed kneeling position

### 3.2 Assault

The subject would walk a short distance, as if on patrol, then as if encountering fire would take cover, adopt the prone position and simulate returning fire, as shown in Figures 15 and 16.



Figure 15 – Taking cover during an assault



Figure 16 – Prone position taking aim during an assault

The subject would then rotate onto their right hip to simulate reloading their rifle (Figure 17) and take aim once more, before standing (Figure 18).



Figure 17 – Hip re-load during an assault



Figure 18 – Standing recovery after performing an assault

### 3.3 Leopard Crawl

The subject would begin from standing and then drop to the floor to perform a leopard crawl, as shown in Figure 19.



Figure 19 – Leopard crawl

A SA80 rifle was used for each exercise. The exercises were performed for a maximum duration of 1 minute, followed by a minimum of 1 minute rest. The tempo of the exercises was determined by the individual subject; therefore there was no limit on the number of times each exercise was performed within the 1 minute time period.

### 3.4 Subjects

Three UK military subjects took part in the field trials. The subjects varied in mass, height and stature, and also came from different regiments within the British Army. Table 1 provides the information for the three subjects, referred to as Subjects A, B and C.

<i>Subject</i>	<i>Mass / kg</i>	<i>Height / cm</i>	<i>Regiment</i>
A	83	178	Mercian Regt
B	87	182	Royal Logistics Core
C	91	188	Royal Tank Regt

Table 1 – Subject information

### 3.5 Field trial variables

A number of variables were investigated during the trials including:

- i. Type of exercise
  - a. Kneeling
  - b. Assault
  - c. Leopard crawl
- ii. Subject
  - a. A
  - b. B
  - c. C
- iii. Terrain
  - a. Grassland
  - b. Laboratory on ¼-inch carpet underlay
- iv. Equipment load
  - a. No kit
  - b. Additional combat webbing and back pack (collectively weighing approximately 15 kg)

### 3.6 Pressure sensor configuration

The location of the pressure sensors within the suit varied depending upon the exercise being assessed. A total of four sensor configurations were used during the trial; the configurations are shown in Figures 20 to 23 where the black dot represents the sensor origin (refer to Appendix A). The configurations include:

Configuration 1 was used to assess ‘kneeling’ and the ‘leopard crawl’.

Configuration 2 was used to assess the ‘assault’ only.

Configuration 3 was used to assess ‘kneeling’, the ‘assault’ and the ‘leopard crawl’.

Configuration 4 was used to assess the ‘assault’ only.

**Configuration 1**

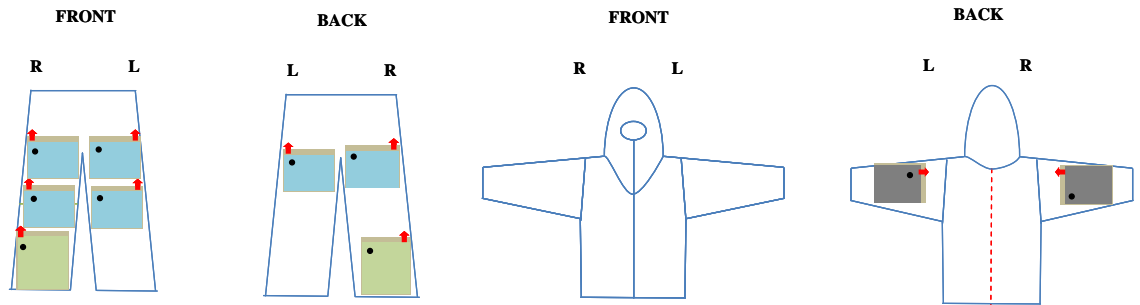

Figure 20 – Suit configuration 1 used to assess ‘kneeling’ and the ‘leopard crawl’

**Configuration 2**

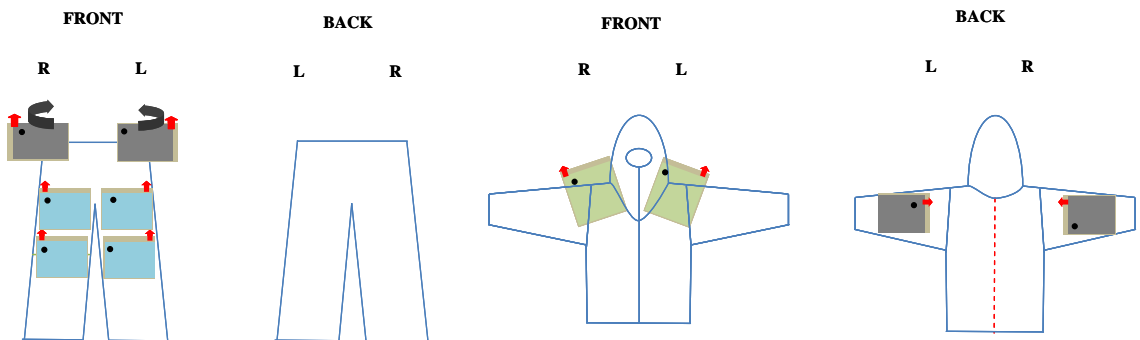

Figure 21 – Suit configuration 2 used to assess the ‘assault’ only

**Configuration 3**

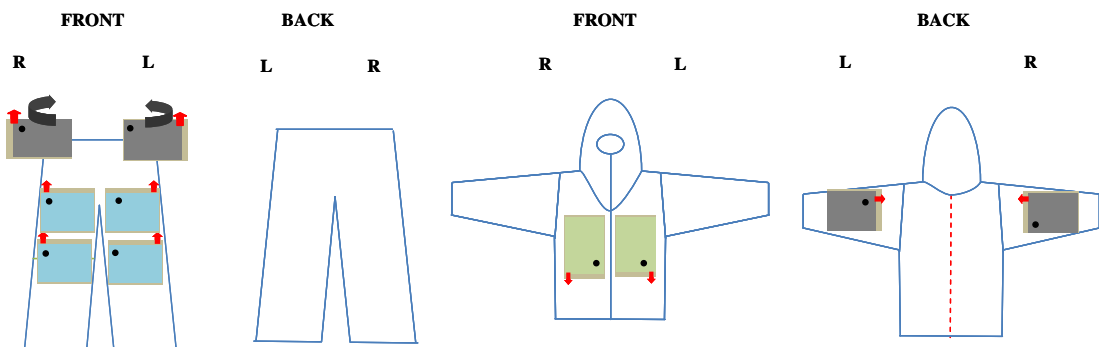

Figure 22 – Suit configuration 3 used to assess ‘kneeling’, the ‘assault’ and the ‘leopard crawl’

**Configuration 4**

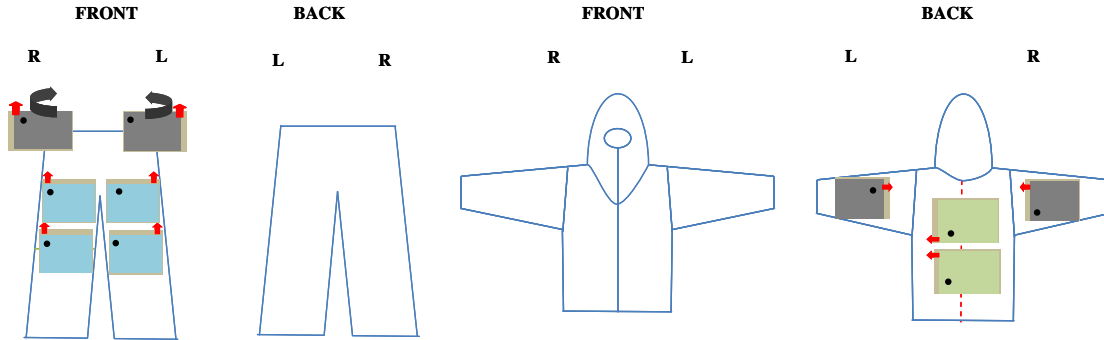
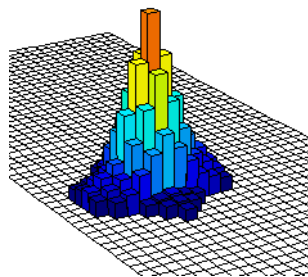

Figure 23 – Suit configuration 4 used to assess the ‘assault’ only

## 4 Data Presentation

The sensor network reliably achieved a sampling rate in the region of 33 Hz. Figure 24 illustrates example data captured for three individual time frames. For each time frame of data it is possible to display the ‘average pressure’ experienced, by summing the individual pressures for each active sensel (i.e. sensor point) and dividing this by the total number of active sensels. Alternatively, the ‘peak pressure’ can be displayed, which corresponds to the individual sensel that gives the largest pressure response across the sensor pad for each time frame.



$t = 1$

Average pressure =  $x_1$

Peak pressure =  $y_1$

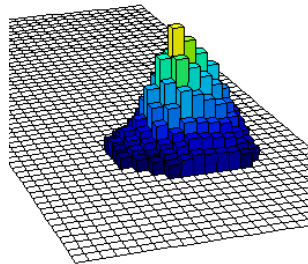

$t = 2$

Average pressure =  $x_2$

Peak pressure =  $y_2$

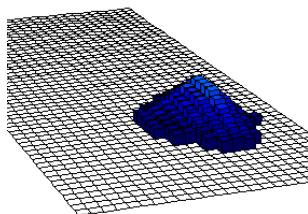

$t = n$

Average pressure =  $x_n$

Peak pressure =  $y_n$

Figure 24 – Pressure data for a given location taken at time ‘t’ during an exercise

For the purpose of this report, the data has been represented as the ‘mean pressure’ (Equation 1) and ‘peak pressure’ (Equation 2).

- i. Mean pressure – ‘the average of the average pressures recorded during an exercise’, defined by Equation 1:

$$\text{Mean pressure} = \frac{\sum (x_1 + x_2 + \dots + x_n)}{n} \quad [1]$$

where  $x_n$  represents the average pressure over a sensor pad at time frame ‘n’ during an exercise.

- ii. Peak pressure – ‘the absolute maximum pressure recorded over a single sensel during an exercise’, defined by Equation 2:

$$\text{Peak pressure} = y_{\max} \quad [2]$$

In cases where the recorded peak pressures have been very high (i.e. in the order of mega-Pascals), a pressure distribution has been generated to reveal the frequency at which these high pressures were encountered during an exercise.

All pressure readings recorded were within the calibration range of the sensors. Pressure values that fell below the calibration range of the sensors have been treated as ‘zero’ values and those that fell above the upper calibration limit were recorded as the maximum calibrated pressure (i.e. 1379 kPa). The averaged data was calculated from ‘non-zero’ values only (i.e. no data could be obtained from inactive sensels or from sensels that fell below the lower calibration limit). For future design, it would be desirable to increase the dynamic range of the sensor pads.

## 5 Results

### 5.1 Kneeling

#### 5.1.1 Subject A (Grassland)

##### 5.1.1.1 Mean Pressure

The mean pressures obtained for each location during the kneeling exercise, performed on grassland by Subject A, are displayed in Figure 25 and tabulated in Table 2.

For this exercise, the calibration range for all the sensors was set to 68.9 kPa to 1379 kPa (i.e. 10 psi to 200 psi). Therefore, where ‘zero’ values were recorded during points of contact, it can be concluded that these values were less than 68.9 kPa.

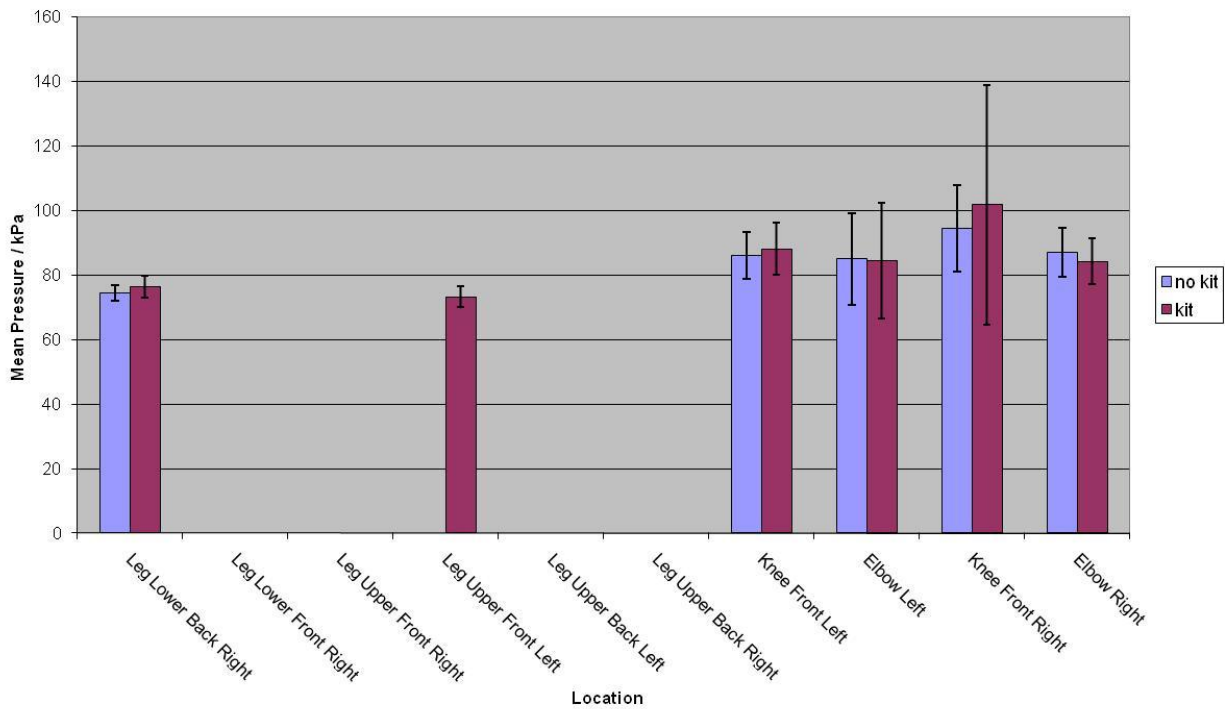

Figure 25 – Mean pressures calculated for the kneeling exercise performed on grassland by Subject A.

**UNCLASSIFIED**

	<i>Mean Pressure / kPa</i>	<i>SD</i>	<i>Kit</i>	<i>Change due to kit / %</i>
<b>Leg Lower Back Right</b>	74.5	2.4	No	2.4
	76.3	3.3	Yes	
<b>Leg Lower Front Right</b>	< 68.9	-	No	-
	< 68.9	-	Yes	
<b>Leg Upper Front Right</b>	< 68.9	-	No	-
	< 68.9	-	Yes	
<b>Leg Upper Front Left</b>	< 68.9	-	No	-
	73.2	3.3	Yes	
<b>Leg Upper Back Left</b>	< 68.9	-	No	-
	< 68.9	-	Yes	
<b>Leg Upper Back Right</b>	< 68.9	-	No	-
	< 68.9	-	Yes	
<b>Knee Front Left</b>	86	7.2	No	2.3
	88	8.1	Yes	
<b>Elbow Left</b>	85	14.1	No	-0.7
	84.4	17.9	Yes	
<b>Knee Front Right</b>	94.5	13.4	No	7.6
	101.7	37.1	Yes	
<b>Elbow Right</b>	87.1	7.6	No	-3.3
	84.2	7.2	Yes	
<b>Average %</b>				<b>2</b>

Table 2 – Mean pressures, and standard deviations of the mean (SD), calculated for the kneeling exercise performed on grassland by Subject A.

For the initial kneeling exercise performed without the additional webbing and back pack, the largest mean pressure of 94.5 kPa was calculated for the right knee (i.e. the knee of the kneeling leg). This increased to 101.7 kPa when performing the exercise with additional kit.

A mean pressure of 74.5 kPa (without kit) was calculated for the ‘leg lower back right’, which increased to 76.3 kPa with kit. This was attributed to the force generated by the subject adopting the more relaxed kneeling position, where his body weight was shifted on to the back of the heel of the kneeling leg (as shown in Figure 14).

A mean pressure of 73.2 kPa was observed for the ‘leg upper front left’ with kit. This may have been caused by the subject leaning on this leg with his left elbow (as shown in Figure 13).

It is less clear why relatively high mean pressures were observed for the left knee and right elbow. One explanation may be that bending the knee/elbow produced tension in the garment that generated a subsequent compressive force at the centre of the joints, causing one or two sensels to respond. By comparison, when the right knee came into contact with the ground, a large number of sensels would have exhibited a pressure

response; the central sensels would have experienced the majority of the force with the peripheral sensels exhibiting a much lower pressure response, thereby reducing the overall mean pressure.

Performing the kneeling exercise on grassland when wearing the combat webbing and back pack (weighing approximately 15 kg) resulted in an average increase in the mean pressure by 2%, as shown in Table 2; the largest change of 7.6% was observed for the right knee.

**5.1.1.2 Peak Pressure**

The peak pressures recorded during the kneeling exercise, performed on grassland by Subject A, are shown in Figure 26 and tabulated in Table 3. The largest peak pressure of 498 kPa was recorded for the right knee, which was increased by 117% to 1078 kPa with the additional kit load. Overall, a net increase in the peak pressures of 36% was observed when performing the exercise with the combat webbing and back packs (Table 3).

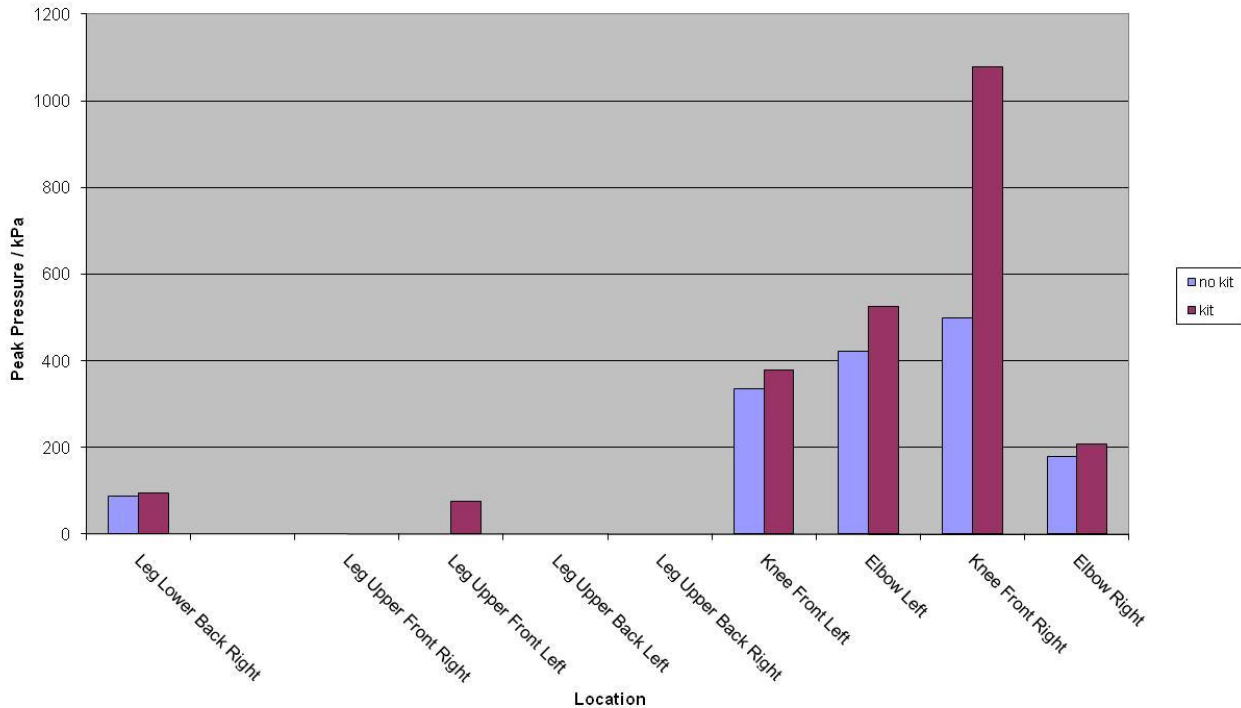

Figure 26 – Peak pressures recorded for the kneeling exercise performed on grassland by Subject A.

**UNCLASSIFIED**

	<i>Peak Pressure / kPa</i>	<i>Kit</i>	<i>Change %</i>
<b>Leg Lower Back Right</b>	86.6	No	8.8
	94.2	Yes	
<b>Leg Lower Front Right</b>	< 68.9	No	-
	< 68.9	Yes	
<b>Leg Upper Front Right</b>	< 68.9	No	-
	< 68.9	Yes	
<b>Leg Upper Front Left</b>	< 68.9	No	-
	76.7	Yes	
<b>Leg Upper Back Left</b>	< 68.9	No	-
	< 68.9	Yes	
<b>Leg Upper Back Right</b>	< 68.9	No	-
	< 68.9	Yes	
<b>Knee Front Left</b>	335.6	No	12.8
	378.5	Yes	
<b>Elbow Left</b>	422.6	No	24.5
	526.1	Yes	
<b>Knee Front Right</b>	498	No	116.5
	1078.1	Yes	
<b>Elbow Right</b>	178.6	No	16.6
	208.3	Yes	
<b>Average %</b>			<b>36</b>

Table 3 – Peak pressures recorded for kneeling performed on grassland by Subject A.

For both knees and elbows, there was a large difference between the calculated mean pressures and the recorded peak pressures. Figure 27 displays a distribution of the peak pressures for the right knee. This data demonstrates that although a peak pressure of 1078 kPa was recorded when performing the exercise with the additional kit, over the duration of the exercise this was encountered less than 0.1% of the time

Furthermore, it can be seen from Figure 27 that when conducting the exercise without the additional webbing and back pack, the majority of peak pressures were at or below 350 kPa, whereas with the kit the majority were at or below 450 kPa.

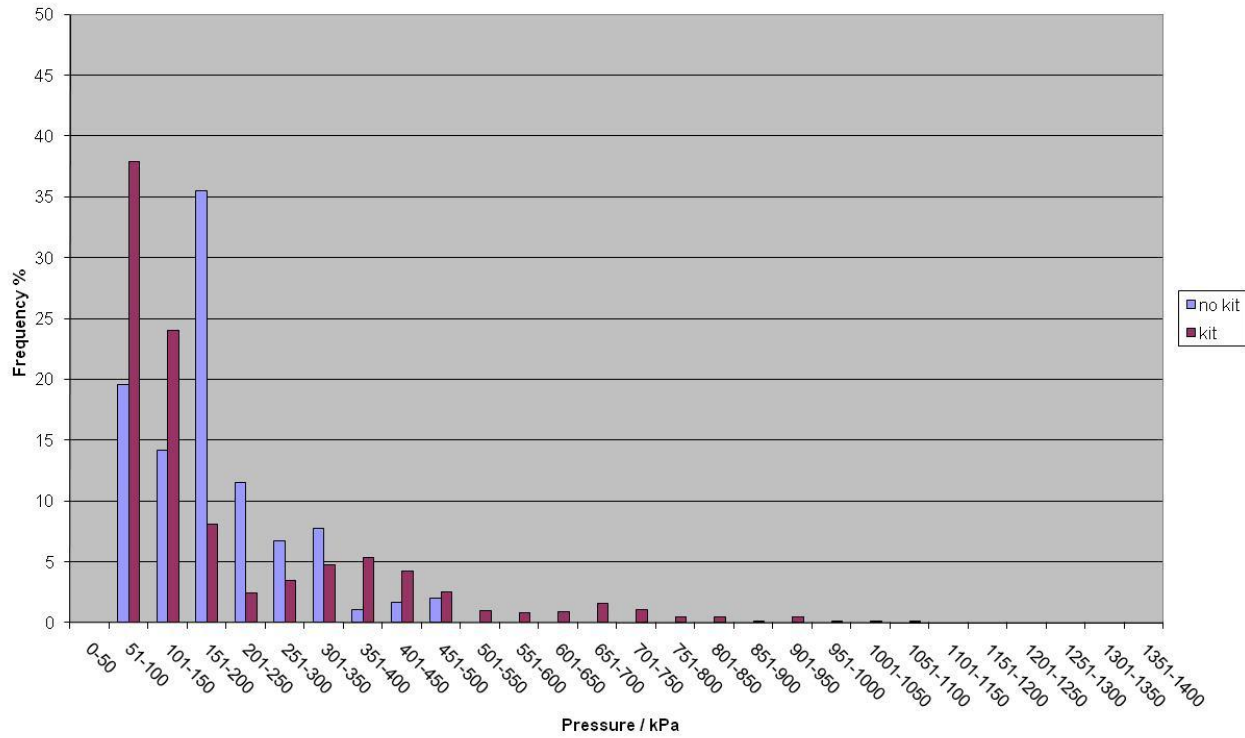

Figure 27 – Peak pressure distribution recorded for right knee during the kneeling exercise performed on grassland by Subject A.

5.1.2 Subject A (Laboratory)

5.1.2.1 Mean Pressure

The mean pressures obtained for each location during the kneeling exercise, performed in the laboratory by Subject A, are displayed in Figure 28 and tabulated in Table 4.

For this exercise, the calibration range for all the sensor pads (excluding those at the knees and elbows/forearms) was set to 34.5 kPa to 344.7 kPa (i.e. 5 psi to 50 psi). Therefore, where ‘zero’ values were recorded during points of contact, it can be concluded that these values were less than 34.5 kPa.

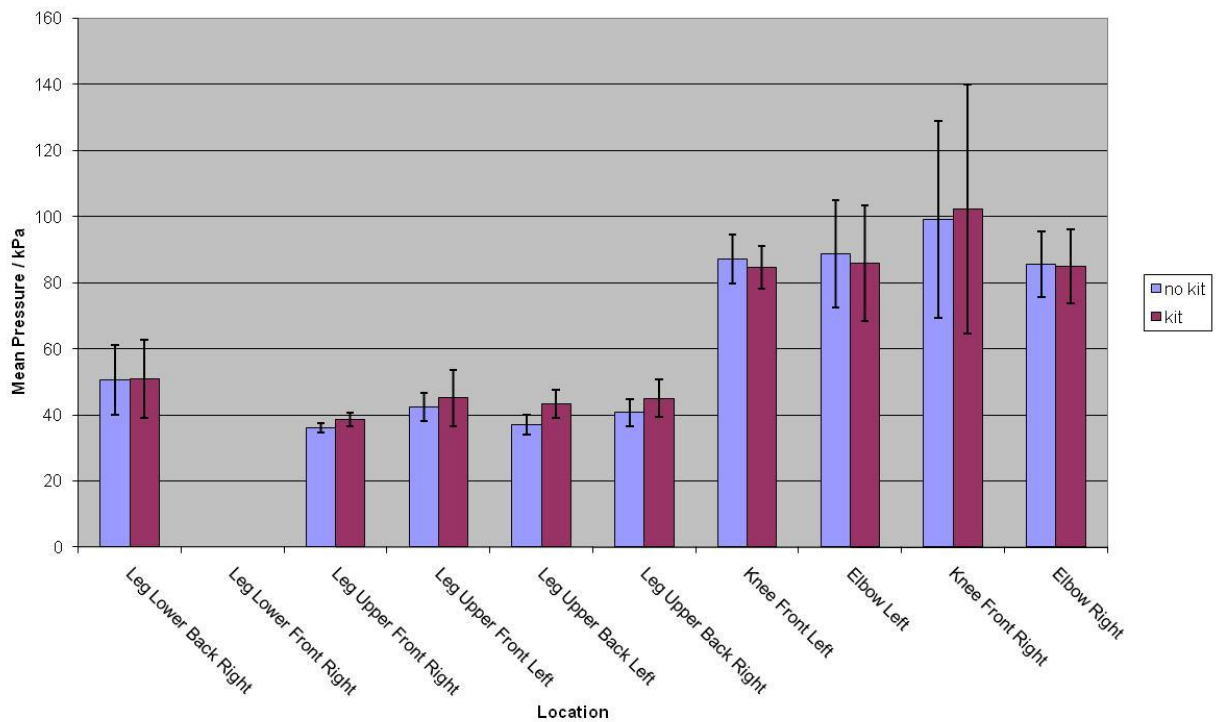

Figure 28 – Mean pressures calculated for the kneeling exercise performed inside the laboratory by Subject A.

**UNCLASSIFIED**

	<i>Mean Pressure / kPa</i>	<i>SD</i>	<i>Kit</i>	<i>Change due to kit / %</i>
<b>Leg Lower Back Right</b>	50.6	10.5	No	0.8
	51.0	11.8	Yes	
<b>Leg Lower Front Right</b>	< 34.5	-	No	6.9
	< 34.5	-	Yes	
<b>Leg Upper Front Right</b>	36.1	1.4	No	-
	38.6	2.1	Yes	
<b>Leg Upper Front Left</b>	42.3	4.3	No	6.6
	45.1	8.6	Yes	
<b>Leg Upper Back Left</b>	37.1	2.9	No	16.7
	43.3	4.2	Yes	
<b>Leg Upper Back Right</b>	40.7	4.1	No	10.6
	45	5.6	Yes	
<b>Knee Front Left</b>	87.1	7.4	No	-2.9
	84.6	6.4	Yes	
<b>Elbow Left</b>	88.7	16.3	No	-3.2
	85.9	17.6	Yes	
<b>Knee Front Right</b>	99.1	29.9	No	3.2
	102.3	37.7	Yes	
<b>Elbow Right</b>	85.6	9.9	No	-0.7
	85.0	11.1	Yes	
<b>Average %</b>				<b>4</b>

Table 4 – Mean pressures, and standard deviations of the mean (SD), calculated for kneeling performed in the laboratory by Subject A.

As shown for the kneeling exercise performed on grassland, the largest mean pressure of 99.1 kPa was found for the right knee, which increased to 102.3 kPa when performing the exercise with the additional kit.

Similar to the findings on grassland, unexpectedly high mean pressures were observed for the left knee and right elbow. The upper legs (front and back) exhibited mean pressures in the region of 40 kPa, whereas the ‘leg lower back right’ produced a mean pressure of approximately 51 kPa, both with and without the webbing and back pack. No response was observed for the ‘leg lower front right’ of the kneeling leg.

As shown in Table 4, performing the exercise when wearing the combat webbing and back pack resulted in an average increase in the mean pressure of 4%, which was similar to the results obtained on grassland. The largest change of 16.7% was observed for the ‘leg upper back left’, and not the right knee.

5.1.2.2 Peak Pressure

The peak pressures recorded during the kneeling exercise, performed inside the laboratory, are shown in Figure 29 and tabulated in Table 5.

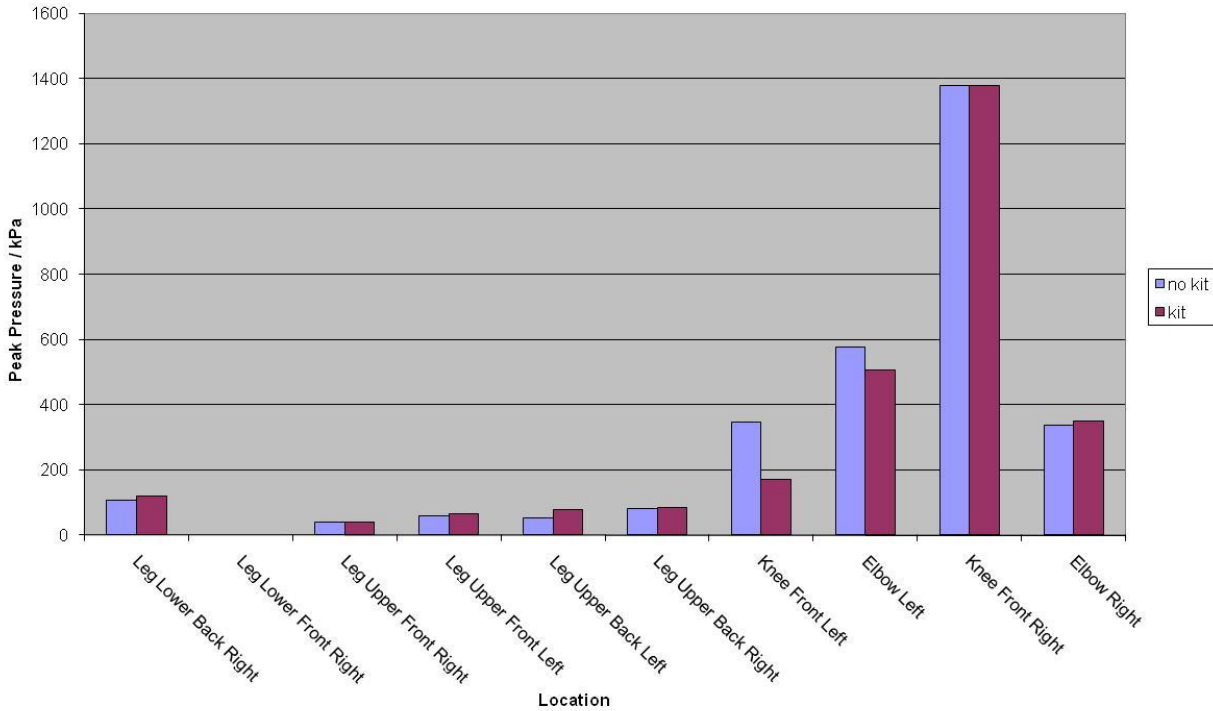

Figure 29 – Peak pressures recorded for the kneeling exercise performed inside the laboratory by Subject A.

As found for the kneeling exercise carried out on grassland, the maximum peak pressure was recorded at the right knee. However, in this instance the peak pressure reached the sensor’s upper calibration limit of 1379 kPa, both with and without the additional kit.

Apart from for the left elbow and left knee, the peak pressures were all greater when the additional kit was worn. Overall, an average increase in the peak pressure of only 3% was observed when performing the exercise with the combat webbing and back pack (Table 5), compared to the 36% observed on grassland. However, this percentage may be different as the change in pressure for the right knee could not be determined as the upper calibration limit had been reached.

**UNCLASSIFIED**

	<i>Peak Pressure / kPa</i>	<i>Kit</i>	<i>Change due to kit / %</i>
<b>Leg Lower Back Right</b>	105.9	No	14.4
	121.2	Yes	
<b>Leg Lower Front Right</b>	< 34.5	No	-
	< 34.5	Yes	
<b>Leg Upper Front Right</b>	39.8	No	3.0
	41	Yes	
<b>Leg Upper Front Left</b>	58.8	No	12.6
	66.2	Yes	
<b>Leg Upper Back Left</b>	52.1	No	48.6
	77.4	Yes	
<b>Leg Upper Back Right</b>	79.9	No	4.0
	83.1	Yes	
<b>Knee Front Left</b>	348.1	No	-50.6
	171.9	Yes	
<b>Elbow Left</b>	575.4	No	-11.9
	507.2	Yes	
<b>Knee Front Right</b>	1379	No	-
	1379	Yes	
<b>Elbow Right</b>	336.3	No	4.2
	350.4	Yes	
<b>Average %</b>			<b>3</b>

Table 5 – Peak pressures recorded for kneeling performed in the laboratory by Subject A.

Figure 30 shows the distributions of the peak pressures for the right knee over the duration of the exercises performed with and without the additional combat kit. The majority of the peak pressures recorded were at or below 450 kPa. The frequency at which the maximum peak pressure of 1379 kPa was encountered during the exercises was approximately 1% without kit and 5% with kit.

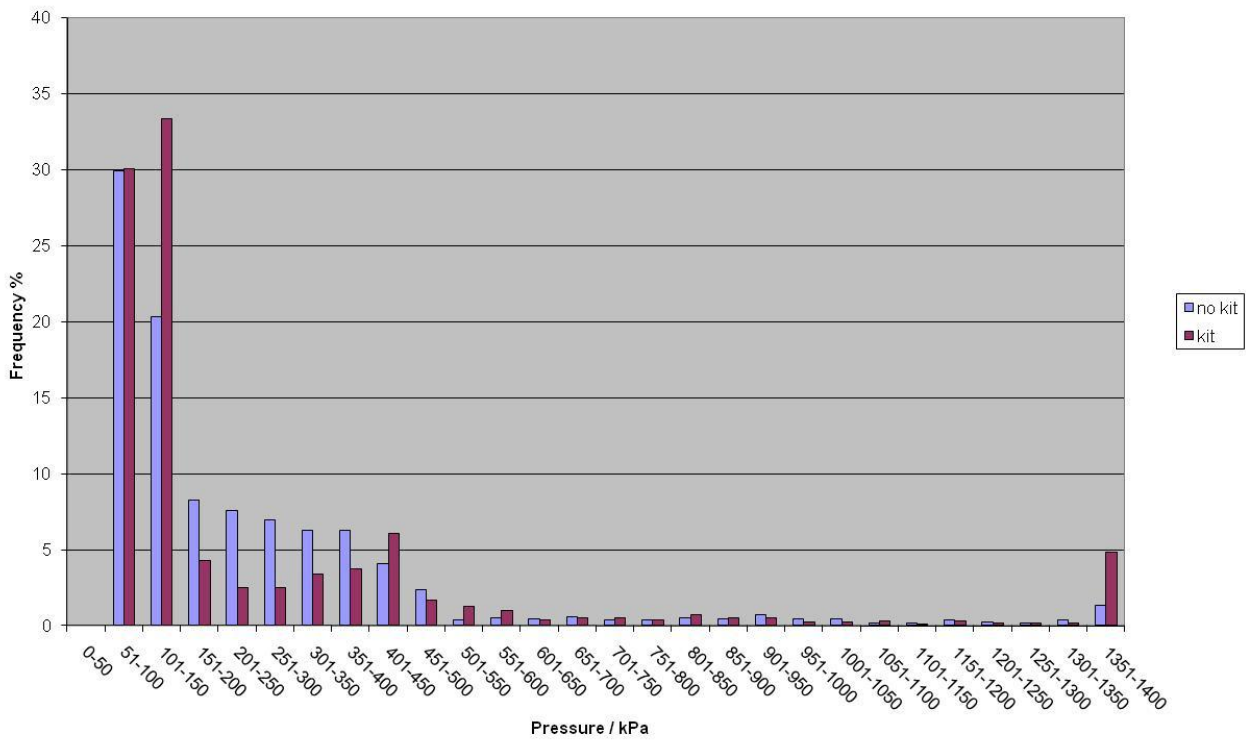

Figure 30 – Peak pressure distribution recorded for the right knee during the kneeling exercise performed in the laboratory by Subject A.

5.1.3 Subject B (Grassland)

5.1.3.1 Mean Pressure

The mean pressures calculated for each location during the kneeling exercise, performed on grassland by Subject B, is shown in Figure 31 and tabulated in Table 6.

The calibration range for all sensor pads, apart from those positioned at the knees and elbows, was set to the lowest calibration range of 34.5 kPa to 344.7 kPa (i.e. 5 psi to 50 psi) in order to capture the lower pressure readings from these body regions. Therefore, where ‘zero’ values were recorded during points of contact, it can be concluded that these values were less than 34.5 kPa.

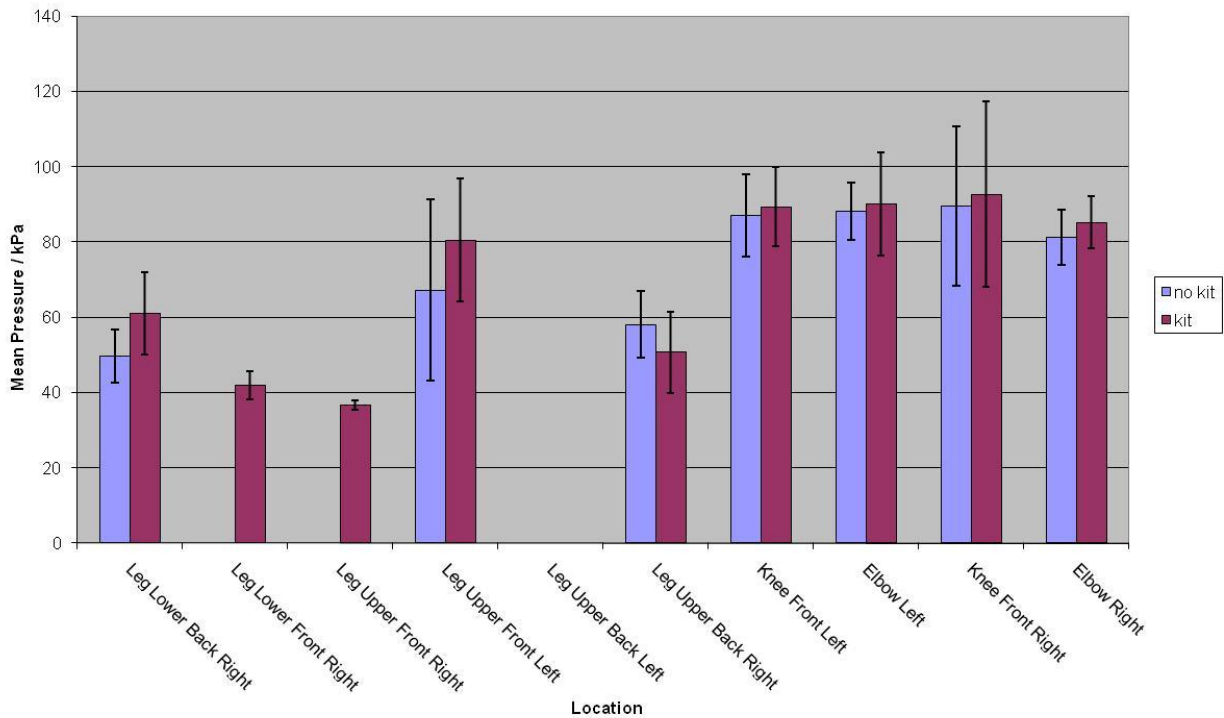

Figure 31 – Mean pressures calculated for the kneeling exercise performed on grassland by Subject B.

**UNCLASSIFIED**

	<i>Mean Pressure / kPa</i>	<i>SD</i>	<i>Kit</i>	<i>Change due to kit / %</i>
<b>Leg Lower Back Right</b>	49.6	7.2	No	23.2
	61.1	10.9	Yes	
<b>Leg Lower Front Right</b>	< 34.5	-	No	-
	42	3.6	Yes	
<b>Leg Upper Front Right</b>	< 34.5	-	No	-
	36.7	1.4	Yes	
<b>Leg Upper Front Left</b>	67.2	24.1	No	19.8
	80.5	16.4	Yes	
<b>Leg Upper Back Left</b>	< 34.5	-	No	-
	< 34.5	-	Yes	
<b>Leg Upper Back Right</b>	58.1	8.8	No	-12.6
	50.8	10.8	Yes	
<b>Knee Front Left</b>	87	11	No	2.6
	89.3	10.5	Yes	
<b>Elbow Left</b>	88.2	7.6	No	3.5
	90.1	13.7	Yes	
<b>Knee Front Right</b>	89.5	21.1	No	2.2
	92.6	24.6	Yes	
<b>Elbow Right</b>	81.3	7.4	No	4.8
	85.2	6.9	Yes	
<b>Average %</b>				<b>6</b>

Table 6 – Mean pressures, and standard deviations of the mean (SD), calculated for kneeling performed on grassland by Subject B.

As found for Subject A, the mean pressure for the right knee (i.e. knee of the kneeling leg) was the highest; 89.5 kPa without the additional kit and 92.6 kPa with the kit. Similar findings were also observed for the right elbow and left knee, which produced unexpectedly high mean pressures.

In general, the results demonstrate that a mean pressure in the region of 90 kPa was obtained for the knees and elbows, whereas the other locations experienced mean pressures within a range of 40 kPa to 80 kPa (similar to that observed with Subject A, both when performing the kneeling exercise on grassland and inside the laboratory).

Apart from the exception of the ‘leg upper back right’, the mean pressure was increased when wearing the additional kit, as shown in Table 6. Overall, there was an average increase in the mean pressure of 6% when adding the webbing and back pack, with the most pronounced increase of 23.2% at the ‘lower leg back right’.

5.1.3.2 Peak Pressure

The peak pressures recorded during the kneeling exercise, performed on grassland by Subject B, are shown in Figure 32 and tabulated in Table 7.

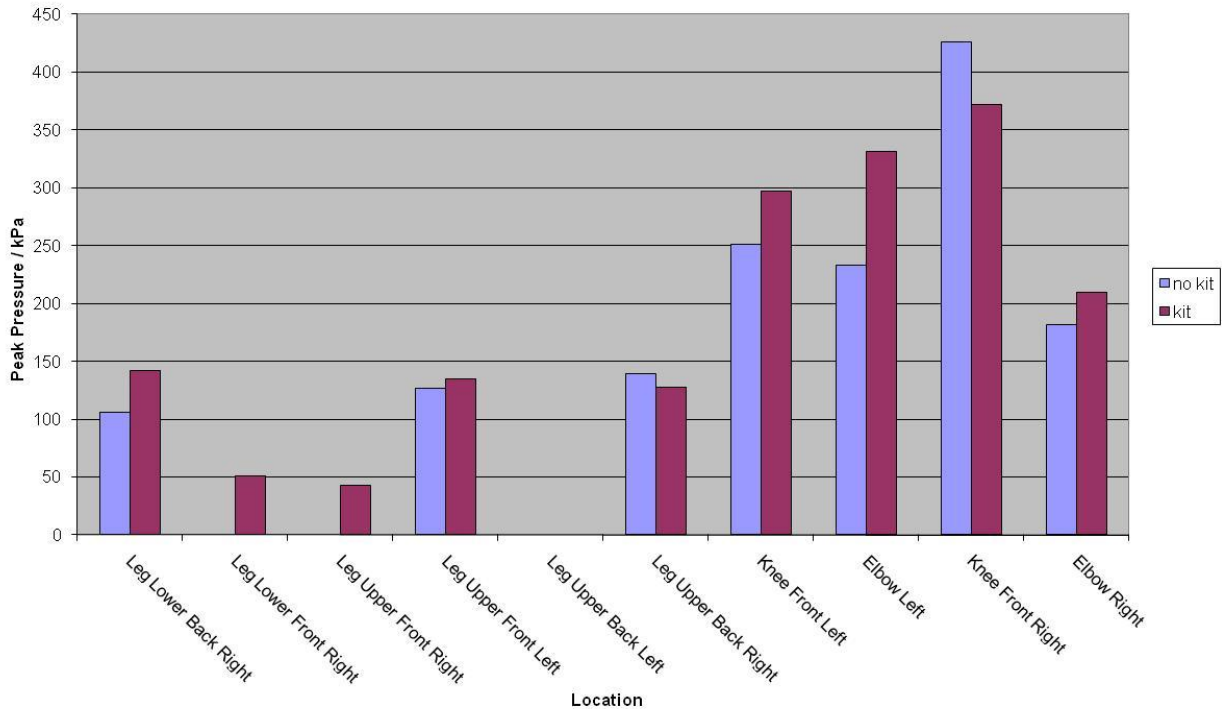

Figure 32 – Peak pressure distribution recorded for the kneeling exercise performed on grassland with additional kit by Subject B.

The maximum peak pressure was recorded at the right knee, as observed for Subject A. However, when performing the exercise with the additional kit the value recorded at the right knee for Subject B (371.8 kPa) was significantly less than that obtained for Subject A (1078 kPa), even though Subject B was 4 kg heavier (Table 1). This effect could be attributed to the noticeably slower tempo at which the exercise was performed by Subject B, in comparison to Subject A.

Furthermore, conducting the exercise with the additional webbing and back pack reduced the peak pressure recorded at the right knee by approximately 13%. This result may have been attributed to the fact that the exercise where the additional kit was worn was performed second. As a consequence, it is a possibility that Subject B became fatigued or experienced a degree of physical discomfort during the first set of kneeling attempts and therefore performed the second set of exercises, with the additional kit, at a slower tempo and with more caution.

**UNCLASSIFIED**

	<i>Peak Pressure / kPa</i>	<i>Kit</i>	<i>Change due to kit / %</i>
<b>Leg Lower Back Right</b>	106.4	No	33.4
	141.9	Yes	
<b>Leg Lower Front Right</b>	< 34.5	No	-
	50.5	Yes	
<b>Leg Upper Front Right</b>	< 34.5	No	-
	43.2	Yes	
<b>Leg Upper Front Left</b>	126.9	No	6.4
	135	Yes	
<b>Leg Upper Back Left</b>	< 34.5	No	-
	< 34.5	Yes	
<b>Leg Upper Back Right</b>	139	No	-8.2
	127.6	Yes	
<b>Knee Front Left</b>	251.5	No	18.2
	297.3	Yes	
<b>Elbow Left</b>	233.2	No	41.9
	331	Yes	
<b>Knee Front Right</b>	425.7	No	-12.7
	371.8	Yes	
<b>Elbow Right</b>	181.9	No	15.2
	209.5	Yes	
<b>Average %</b>			<b>13</b>

Table 7 – Peak pressures recorded for kneeling performed on grassland by Subject B.

Apart from the right knee and the ‘leg upper back right’ the peak pressures were higher when performing the exercise with the additional kit. Overall, there was an average increase in the peak pressures of 13% when the webbing and back pack was worn.

The distributions of the peak pressures for the right knee are shown in Figure 33. The majority of peak pressures recorded (60%) were at or below 100 kPa, both with and without the additional kit.

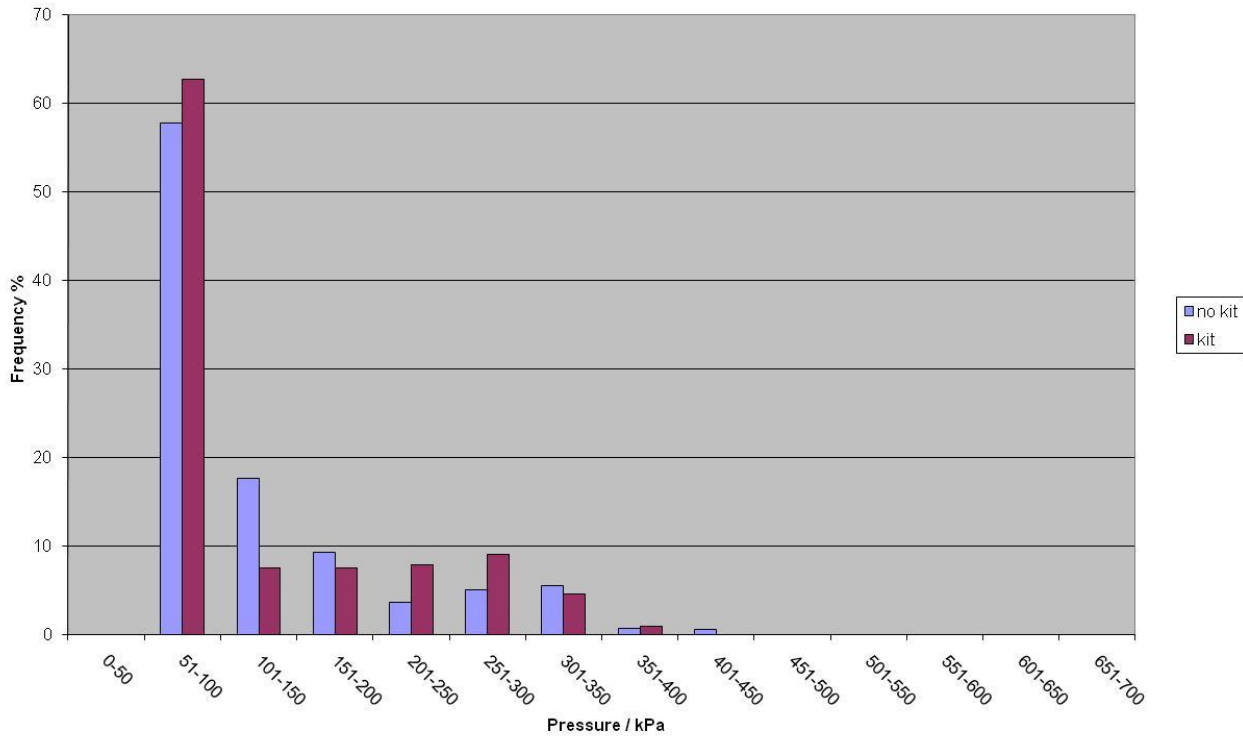

Figure 33 – Peak pressure distribution recorded for the right knee during the kneeling exercise performed on grassland by Subject B.

5.1.4 Subject B (Laboratory)

5.1.4.1 Mean Pressure

The mean pressures obtained for each location during the kneeling exercise, performed in the laboratory by Subject B, are shown in Figure 34 and tabulated in Table 8.

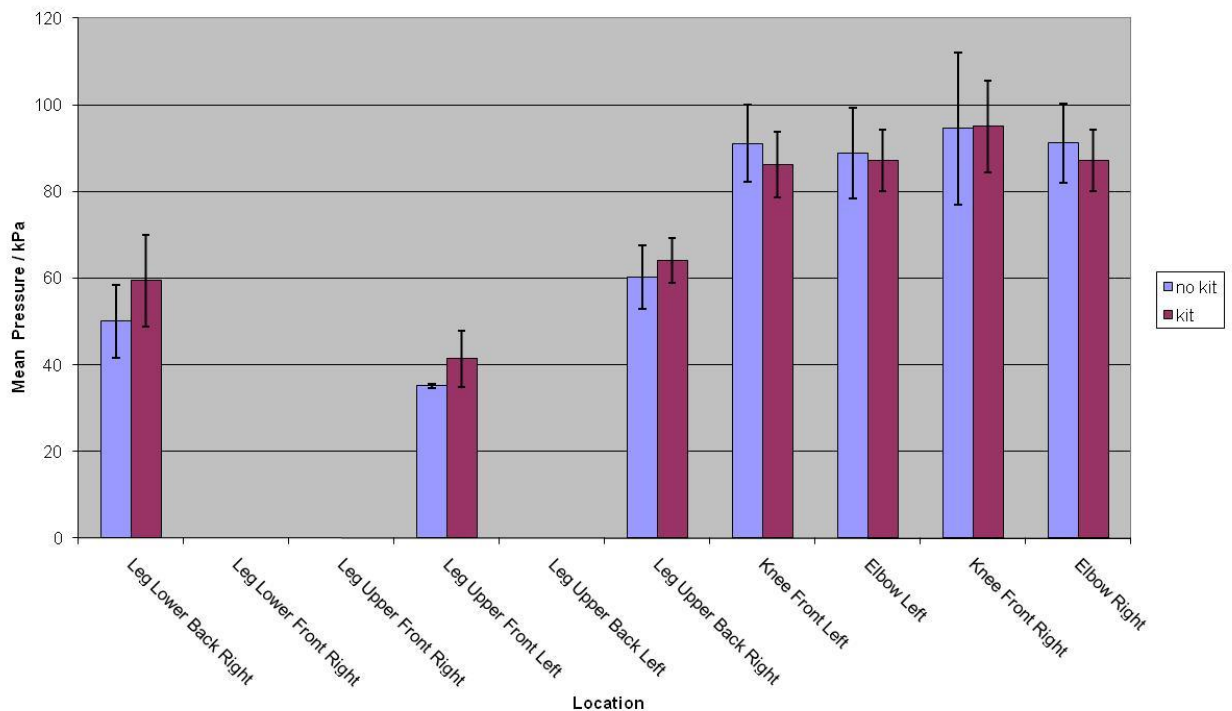

Figure 34 – Mean pressures calculated for the kneeling exercise performed inside the laboratory by Subject B.

The right knee produced the highest mean pressure, as observed previously. Broadly speaking, the values for the knees and elbow fell within 90 kPa to 95 kPa, whereas the rest of the body, namely the upper and lower legs, were in the region 35 kPa to 65 kPa.

Performing the exercise with the additional kit resulted in an average increase in the mean pressures of 5%, which is very similar to the results obtained on grassland. Furthermore, the kit was found to have the biggest impact on the mean pressure obtained for the ‘leg lower back right’, as also found during the exercise performed on grassland.

	<i>Mean Pressure / kPa</i>	<i>SD</i>	<i>Kit</i>	<i>Change due to kit / %</i>
<b>Leg Lower Back Right</b>	50.1	8.4	No	18.6
	59.4	10.6	Yes	
<b>Leg Lower Front Right</b>	< 34.5	< 34.5	No	-
	< 34.5	< 34.5	Yes	
<b>Leg Upper Front Right</b>	< 34.5	< 34.5	No	-
	< 34.5	< 34.5	Yes	
<b>Leg Upper Front Left</b>	35.1	0.4	No	17.9
	41.4	6.5	Yes	
<b>Leg Upper Back Left</b>	< 34.5	< 34.5	No	-
	< 34.5	< 34.5	Yes	
<b>Leg Upper Back Right</b>	60.2	7.3	No	6.5
	64.1	5.2	Yes	
<b>Knee Front Left</b>	91.1	8.9	No	-5.4
	86.2	7.6	Yes	
<b>Elbow Left</b>	88.8	10.6	No	-1.9
	87.1	7	Yes	
<b>Knee Front Right</b>	94.6	17.6	No	0.4
	95	10.6	Yes	
<b>Elbow Right</b>	91.1	9.2	No	-4.3
	87.2	7.1	Yes	
<b>Average %</b>				<b>5</b>

Table 8 – Mean pressures, and standard deviations of the mean (SD), calculated for kneeling performed in the laboratory by Subject B.

#### 5.1.4.2 Peak Pressure

The peak pressures recorded during the kneeling exercise, performed in the laboratory by Subject B, are shown in Figure 35 and tabulated in Table 9.

These results are comparable to the results obtained on the grassland with the right knee producing the highest peak pressure of 439.9 kPa. Similar to the results on grassland, the peak pressure for the right knee was reduced by approximately 9% when the additional kit was worn (Table 9). Overall, an average increase in the peak pressures of 6% was observed by introducing the additional kit.

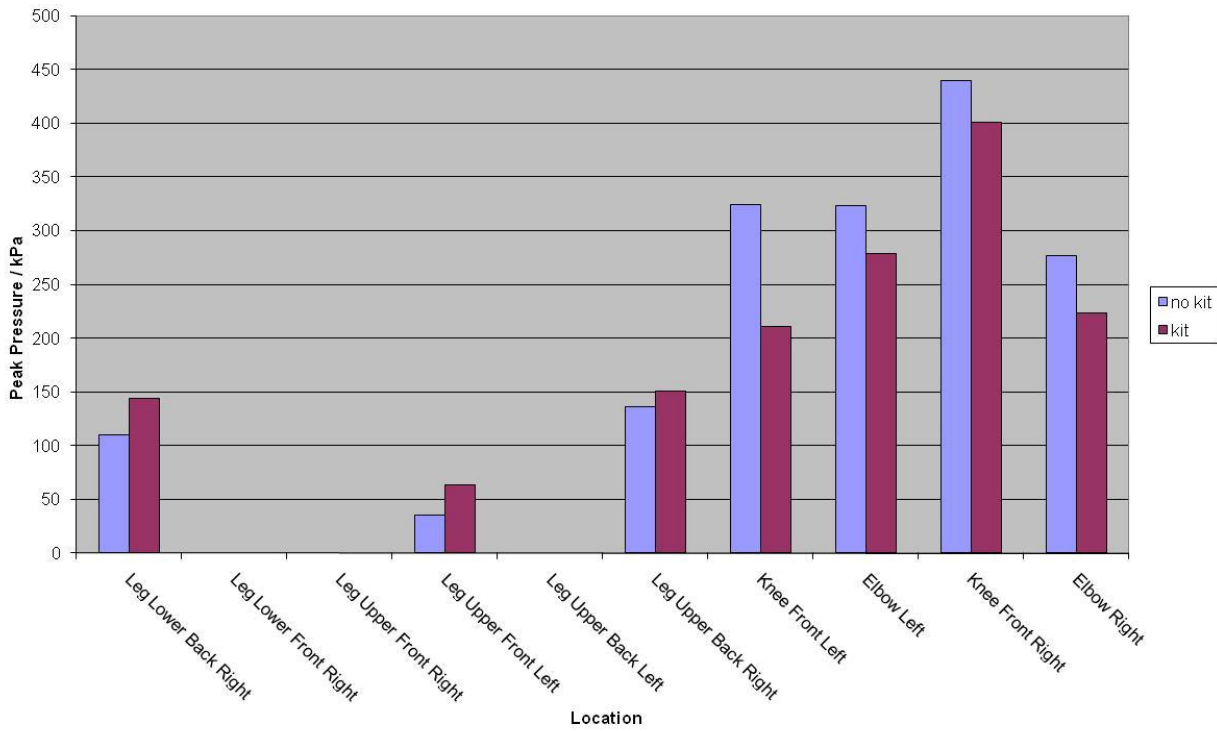

Figure 35 – Peak pressures recorded for the kneeling exercise performed in the laboratory by volunteer B.

**UNCLASSIFIED**

	<i>Peak Pressure / kPa</i>	<i>Kit</i>	<i>Change due to kit / %</i>
<b>Leg Lower Back Right</b>	110.1	No	30.7
	143.9	Yes	
<b>Leg Lower Front Right</b>	< 34.5	No	-
	< 34.5	Yes	
<b>Leg Upper Front Right</b>	< 34.5	No	-
	< 34.5	Yes	
<b>Leg Upper Front Left</b>	35.5	No	78.0
	63.2	Yes	
<b>Leg Upper Back Left</b>	< 34.5	No	-
	< 34.5	Yes	
<b>Leg Upper Back Right</b>	136.4	No	10.9
	151.2	Yes	
<b>Knee Front Left</b>	323.9	No	-35.0
	210.6	Yes	
<b>Elbow Left</b>	323	No	-13.8
	278.4	Yes	
<b>Knee Front Right</b>	439.9	No	-8.8
	401.2	Yes	
<b>Elbow Right</b>	276.5	No	-19.2
	223.5	Yes	
<b>Average %</b>			<b>6</b>

Table 9 – Peak pressures recorded for kneeling performed in the laboratory by Subject B.

The distributions of the peak pressures obtained for the right knee are shown in Figure 36. Unlike the results obtained on grassland, there appeared no clear trend. The majority of peak pressures were at or below 300 kPa.

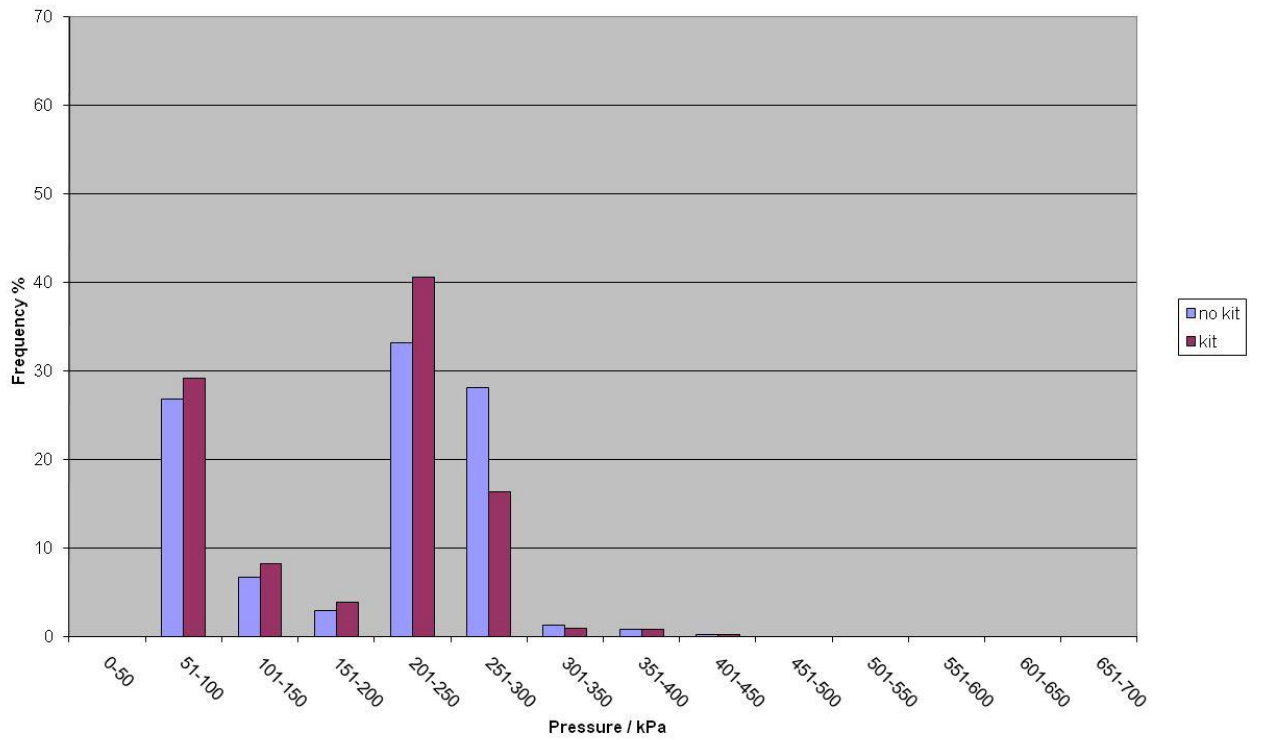

Figure 36 – Peak pressure distribution recorded for the right knee during the kneeling exercise performed in the laboratory by Subject B.

5.1.5 Subject C (Laboratory)

5.1.5.1 Mean Pressure

Owing to poor weather conditions, Subject C had to perform the exercises in the laboratory only.

The mean pressures obtained for each location during the kneeling exercise, performed in the laboratory by Subject C, are shown in Figure 37 and Table 10.

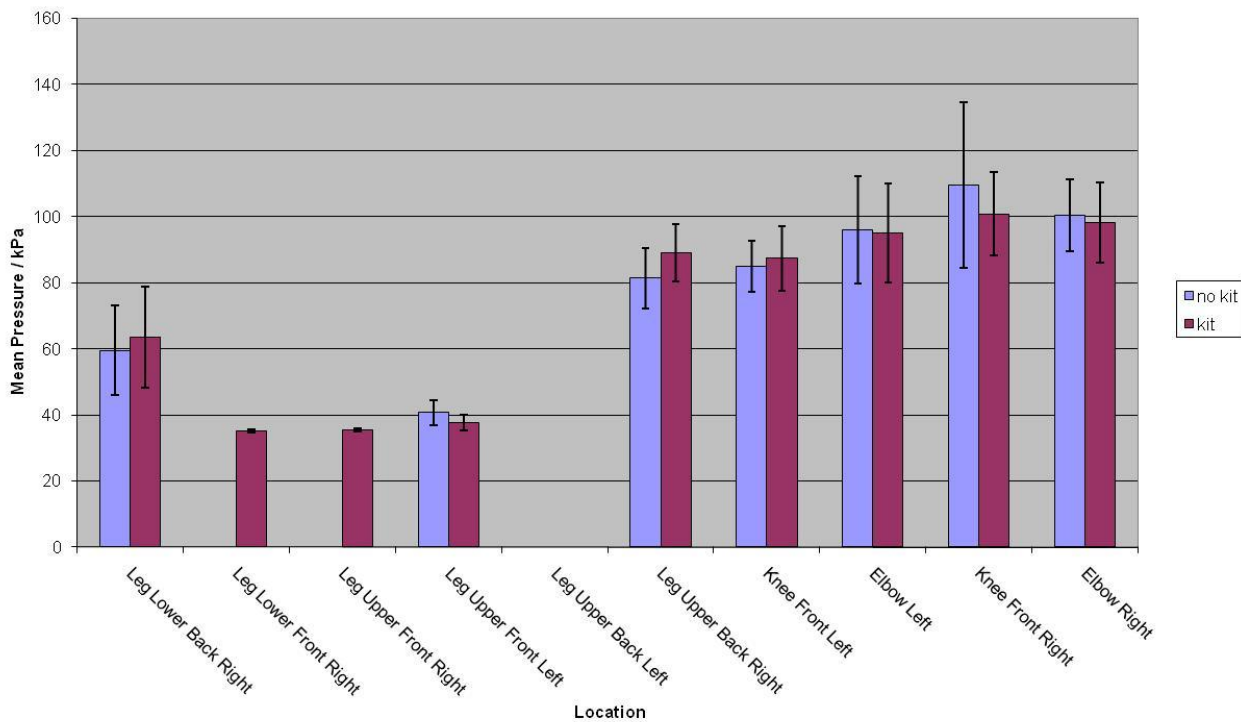

Figure 37 – Mean pressures calculated for the kneeling exercise performed inside the laboratory by Subject C.

**UNCLASSIFIED**

	<i>Mean Pressure / kPa</i>	<i>SD</i>	<i>Kit</i>	<i>Change due to kit / %</i>
<b>Leg Lower Back Right</b>	59.5	13.6	No	6.7
	63.5	15.3	Yes	
<b>Leg Lower Front Right</b>	< 34.5	-	No	-
	35.1	0.5	Yes	
<b>Leg Upper Front Right</b>	< 34.5	-	No	-
	35.5	0.4	Yes	
<b>Leg Upper Front Left</b>	40.8	3.8	No	-8.1
	37.5	2.4	Yes	
<b>Leg Upper Back Left</b>	< 34.5	-	No	-
	< 34.5	-	Yes	
<b>Leg Upper Back Right</b>	81.4	9.1	No	9.5
	89.1	8.8	Yes	
<b>Knee Front Left</b>	84.9	7.7	No	2.9
	87.4	9.7	Yes	
<b>Elbow Left</b>	96	16.1	No	-0.8
	95.2	15	Yes	
<b>Knee Front Right</b>	109.7	25.1	No	-8.2
	100.7	12.6	Yes	
<b>Elbow Right</b>	100.5	10.9	No	-2.4
	98.1	12.2	Yes	
<b>Average %</b>				<b>0</b>

Table 10 – Mean pressures, and standard deviations of the mean (SD), calculated for kneeling performed in the laboratory by Subject C.

The largest mean pressure (109.7 kPa) was observed for the right knee during the exercise where no additional kit was worn. Similar to Subjects A and B, unexpectedly high pressures were produced by the right elbow and left knee. Generally, the mean pressures observed for the knees and elbows were in the region of 90 kPa to 110 kPa, whereas the rest of the body was between 40 kPa and 80 kPa.

The biggest impact on the mean pressures from wearing the additional webbing and back pack was observed for the ‘leg upper back right’ where there was an increase of approximately 10% (Table 10). However, overall, there was no increase in the mean pressures when the exercise was performed with the additional kit. As mentioned previously, this finding may be explained by a change in tempo at which the exercises were carried out when the combat webbing and back pack was worn.

**5.1.5.2 Peak Pressure**

The peak pressures recorded during the kneeling exercise, performed in the laboratory by Subject C, are shown in Figure 38 and Table 11.

The highest peak pressure was observed for the right knee (540.6 kPa), but as found for Subject B, this was significantly less than the peak pressure observed for Subject A (1379 kPa), despite Subject C weighing more than Subject A by 8 kg.

Overall, there was an average increase in the peak pressures of 6% when carrying out the exercise wearing the additional webbing and back pack; this was consistent with the overall net increase found for Subject B.

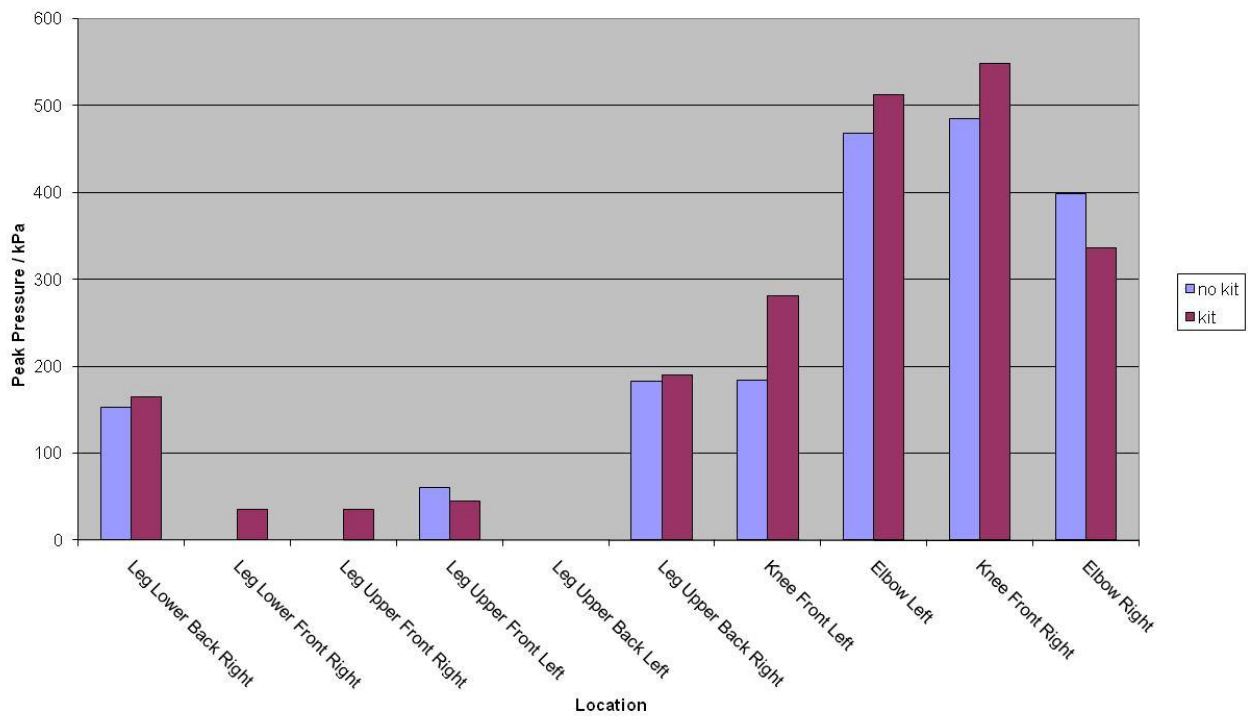

Figure 38 – Peak pressures recorded for the kneeling exercise performed inside the laboratory by Subject C.

**UNCLASSIFIED**

	<i>Peak Pressure / kPa</i>	<i>Kit</i>	<i>Change due to kit / %</i>
<b>Leg Lower Back Right</b>	152.7	No	7.5
	164.2	Yes	
<b>Leg Lower Front Right</b>	< 34.5	No	-
	35.5	Yes	
<b>Leg Upper Front Right</b>	< 34.5	No	-
	35.8	Yes	
<b>Leg Upper Front Left</b>	60.9	No	-26.1
	45	Yes	
<b>Leg Upper Back Left</b>	< 34.5	No	-
	< 34.5	Yes	
<b>Leg Upper Back Right</b>	182.4	No	4.3
	190.3	Yes	
<b>Knee Front Left</b>	183.4	No	53.0
	280.6	Yes	
<b>Elbow Left</b>	468.4	No	9.3
	512	Yes	
<b>Knee Front Right</b>	484.8	No	11.5
	540.6	Yes	
<b>Elbow Right</b>	398.2	No	-15.6
	336.2	Yes	
<b>Average %</b>			<b>6</b>

Table 11 – Peak pressures recorded for kneeling performed in the laboratory by Subject C.

The peak pressure distributions obtained for the right knee are shown in Figure 39. As observed above, the maximum peak pressure recorded was only encountered for a very small fraction of time (less than 0.1%) throughout the exercise and the majority of the peak pressures were at or below 350kPa.

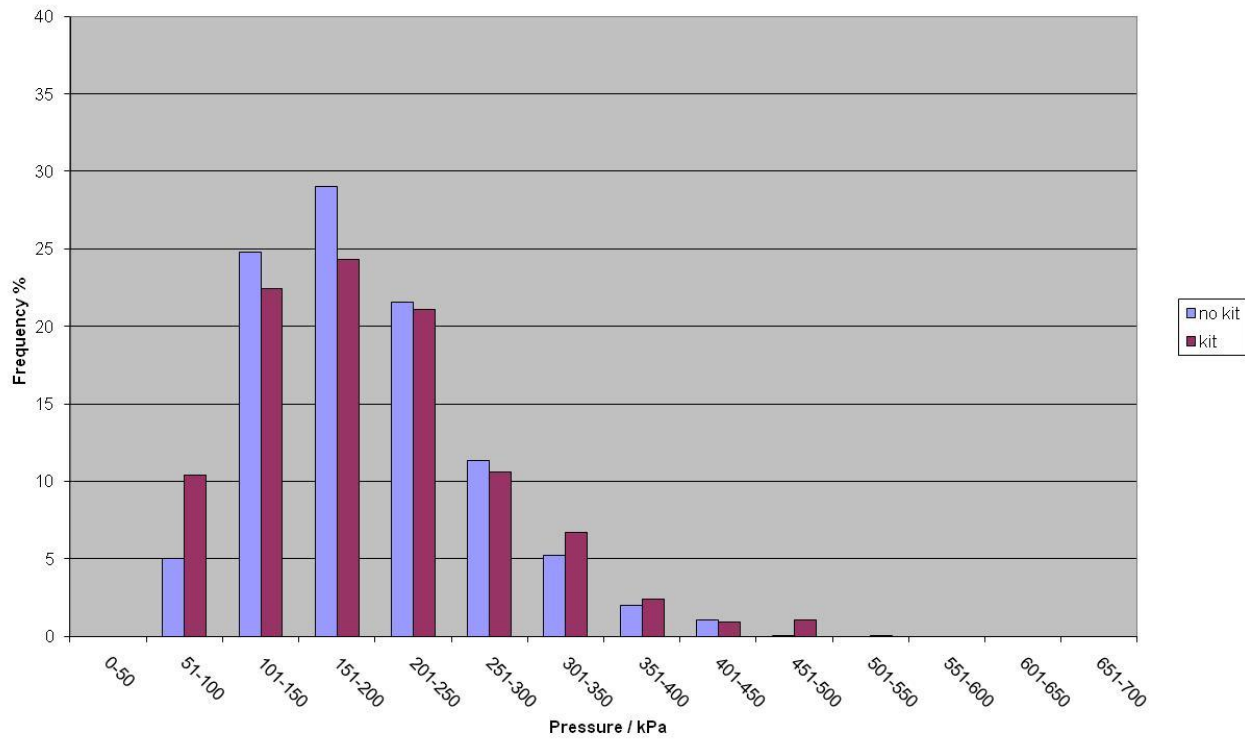

Figure 39 – Peak pressure distribution recorded for the right knee during the kneeling exercise performed in the laboratory by Subject C.

5.2 Assault

5.2.1 Subject A (Grassland)

5.2.1.1 Mean Pressure

The mean pressures obtained for each location during the assault exercise, performed on grassland by Subject A, are shown in Figure 40 and Table 12. The calibration range for all the sensor pads (excluding those at the knees and elbows/forearms) was set to 34.5 kPa to 344.7 kPa (i.e. 5 psi to 50 psi).

Owing to the nature of this exercise, pressure readings were recorded from more locations across the body, in comparison to the kneeling exercise. Consequently, this meant the exercise had to be performed a number of times to allow the sensors to be exchanged between the different locations. Measurements for the shoulders and back were only taken when the additional kit was worn.

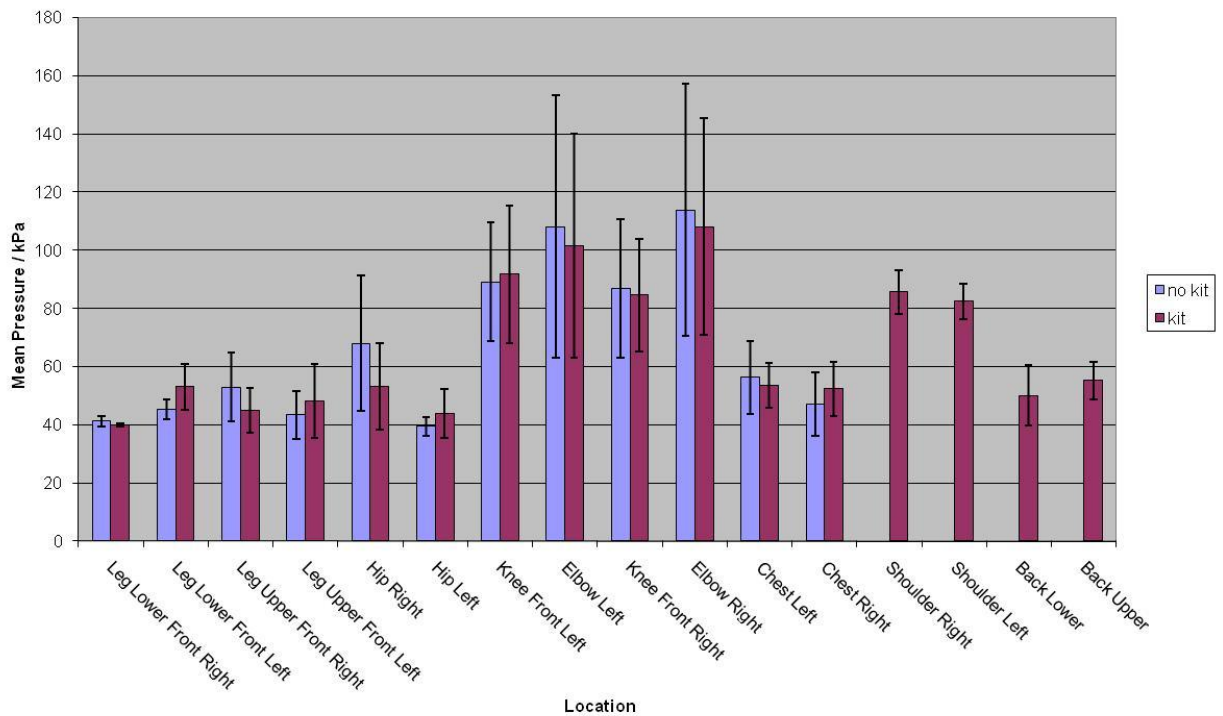

Figure 40 – Mean pressures obtained for the assault exercise performed on grassland by Subject A.

**UNCLASSIFIED**

	<i>Mean Pressure / kPa</i>	<i>SD</i>	<i>Kit</i>	<i>Change due to kit / %</i>
<b>Leg Lower Front Right</b>	41.2	1.7	No	-3.4
	39.8	0.5	Yes	
<b>Leg Lower Front Left</b>	45.2	3.4	No	17.5
	53.1	7.9	Yes	
<b>Leg Upper Front Right</b>	53	12	No	-14.9
	45.1	7.8	Yes	
<b>Leg Upper Front Left</b>	43.4	8.3	No	11.3
	48.3	12.8	Yes	
<b>Hip Right</b>	68	23.3	No	-21.9
	53.1	14.8	Yes	
<b>Hip Left</b>	39.5	3.3	No	11.1
	43.9	8.5	Yes	
<b>Knee Front Left</b>	89	20.4	No	3.1
	91.8	23.6	Yes	
<b>Elbow Left</b>	108.1	45	No	-6.0
	101.6	38.6	Yes	
<b>Knee Front Right</b>	86.9	23.8	No	-2.6
	84.6	19.3	Yes	
<b>Elbow Right</b>	113.8	43.3	No	-5.0
	108.1	37.1	Yes	
<b>Chest Left</b>	56.2	12.4	No	-4.6
	53.6	7.8	Yes	
<b>Chest Right</b>	47.1	11	No	11.3
	52.4	9.3	Yes	
<b>Shoulder Left</b>	-		No	-
	82.5	6.1	Yes	
<b>Shoulder Right</b>	-		No	-
	85.7	7.5	Yes	
<b>Back Lower</b>	-		No	-
	50.1	10.3	Yes	
<b>Back Upper</b>	-		No	-
	55.2	6.6	Yes	
<b>Average %</b>				<b>0</b>

Table 12 – Mean pressures, and standard deviations of the mean (SD), calculated for the assault exercise performed on grassland by Subject A.

For this exercise the highest mean pressures, 108.1 kPa and 113.8 kPa, were observed for the left and right elbows, respectively. The standard deviation of the means was also the largest for these two locations. Broadly speaking, as observed for the kneeling exercise, the mean pressures for the knees and elbows were in the region of 85 kPa to 110 kPa. Reasonably high mean pressures of approximately 80 kPa were generated at the

shoulders through the addition of the combat webbing and back pack. The remaining locations produced mean pressures between 40 kPa and 60 kPa.

Excluding the shoulders and back, overall, there was no increase in the mean pressures when the additional kit was worn (Table 12). In fact, from the 12 locations assessed, 7 locations displayed mean pressures that were higher when no additional kit was worn.

### 5.2.1.2 Peak Pressure

The peak pressures recorded during the assault exercise for Subject A are displayed in Figure 41 and Table 13.

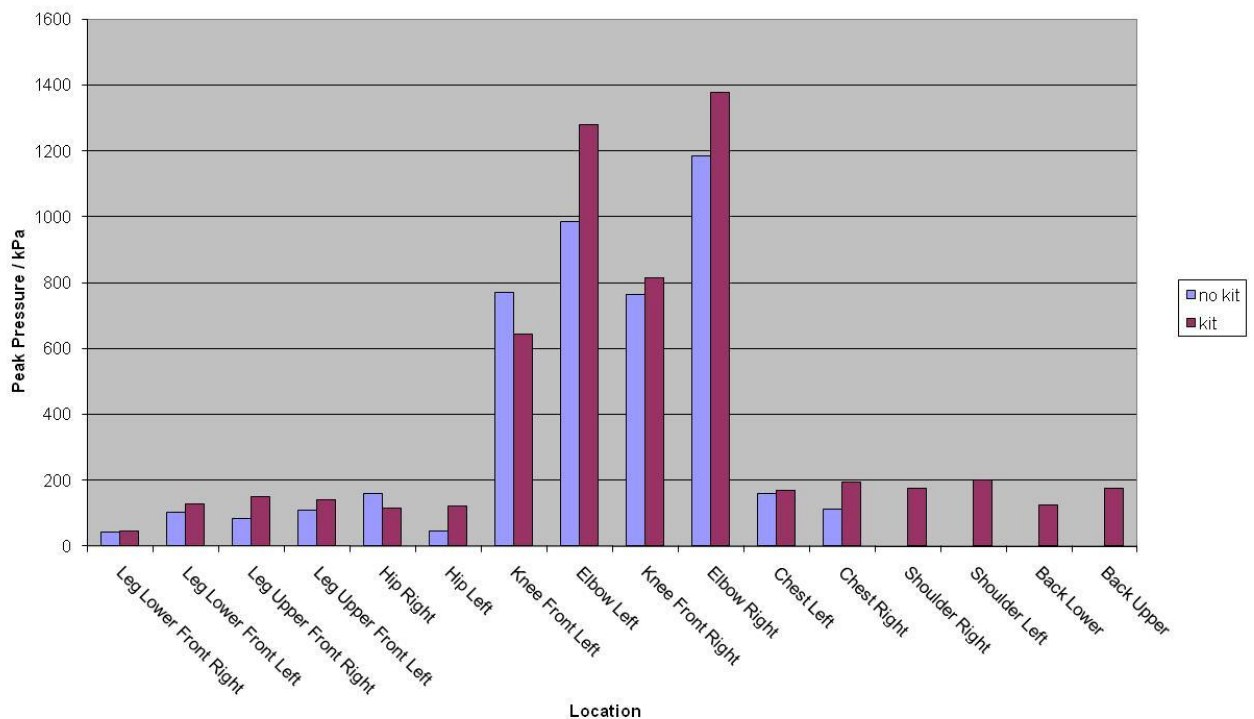

Figure 41 – Peak pressures recorded for the assault exercise performed on grassland by Subject A.

Extremely high peak pressures were observed for both the right and left elbows without the additional kit (1186.0 kPa and 985.5 kPa, respectively). Performing the exercise with the additional kit resulted in a 16% and 30% increase in the recorded peak pressures for the right and left elbows, respectively (Table 13).

Peak pressures recorded at the other locations were typically less than 200 kPa, which was similar to those obtained for the kneeling exercises.

**UNCLASSIFIED**

Overall, performing the assault exercise with the additional webbing and back pack resulted in an average increase of 33% in the peak pressures.

	<i>Peak Pressure / kPa</i>	<i>Kit</i>	<i>Change due to kit / %</i>
<b>Leg Lower Front Right</b>	44.2	No	4.1
	46	Yes	
<b>Leg Lower Front Left</b>	101.3	No	27.6
	129.3	Yes	
<b>Leg Upper Front Right</b>	85.3	No	77.1
	151.1	Yes	
<b>Leg Upper Front Left</b>	110.4	No	26.8
	140	Yes	
<b>Hip Right</b>	160	No	-28.8
	114	Yes	
<b>Hip Left</b>	44.4	No	175.7
	122.4	Yes	
<b>Knee Front Left</b>	769.4	No	-16.5
	642.6	Yes	
<b>Elbow Left</b>	985.5	No	29.7
	1278.3	Yes	
<b>Knee Front Right</b>	763.1	No	6.7
	814.1	Yes	
<b>Elbow Right</b>	1186	No	16.3
	1379	Yes	
<b>Chest Left</b>	158.6	No	7.0
	169.7	Yes	
<b>Chest Right</b>	113.8	No	72.0
	195.7	Yes	
<b>Shoulder Left</b>	-	No	-
	202.3	Yes	
<b>Shoulder Right</b>	-	No	-
	174.3	Yes	
<b>Back Lower</b>	-	No	-
	124.6	Yes	
<b>Back Upper</b>	-	No	-
	175.5	Yes	
<b>Average %</b>			<b>33</b>

Table 13 – Peak pressures recorded for the assault exercise performed on grassland by Subject A.

Figure 42 shows the distributions of peak pressures for the right elbow recorded during the assault exercise. The majority of the peak pressures (approximately 60%) were at or below 150 kPa and the extremely high peak pressure of 1379 kPa was observed for less

than 0.1% of the exercise. Similar trends were also observed for the left elbow and left and right knees (Appendix C).

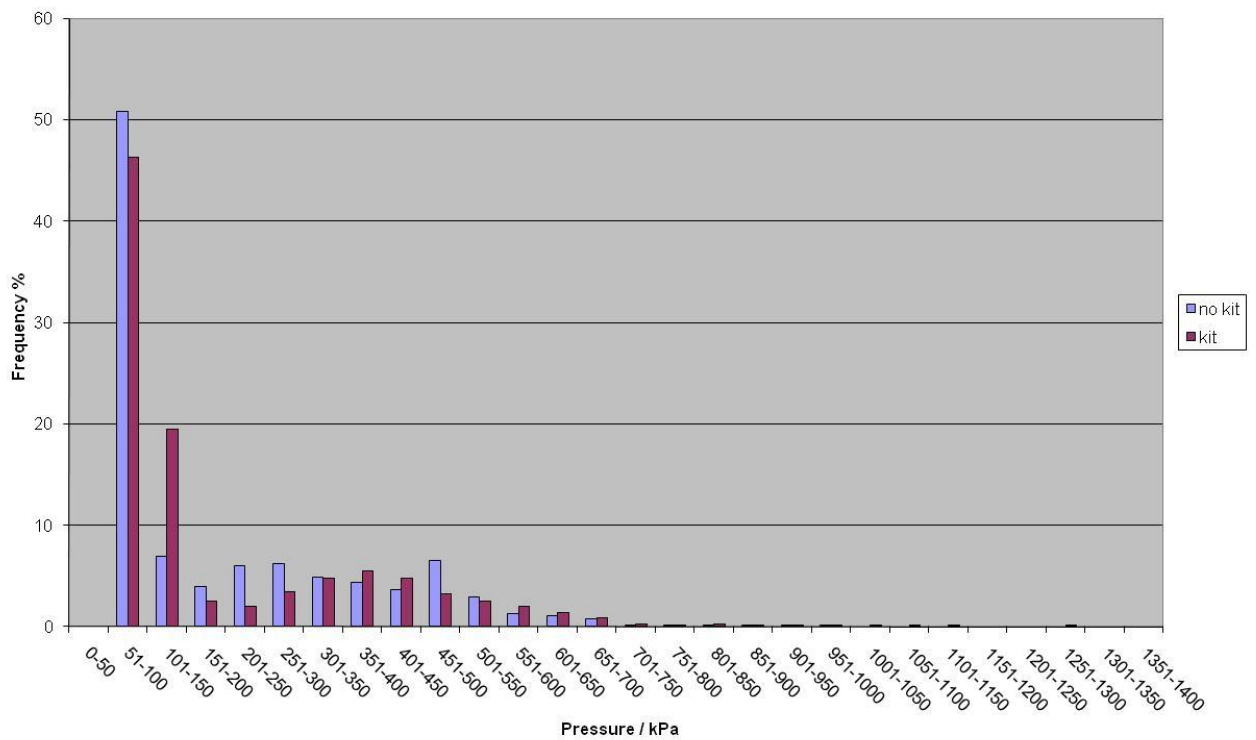

Figure 42 – Peak pressure distribution recorded for the right elbow during the assault exercise performed on grassland by Subject A.

## 5.2.2 Subject A (Laboratory)

### 5.2.2.1 Mean Pressure

The mean pressures obtained for each sensor location during the assault exercise performed in the laboratory by Subject A, are shown in Figure 43 and Table 14.

Measurements for the shoulders and back were only taken when the additional kit was worn.

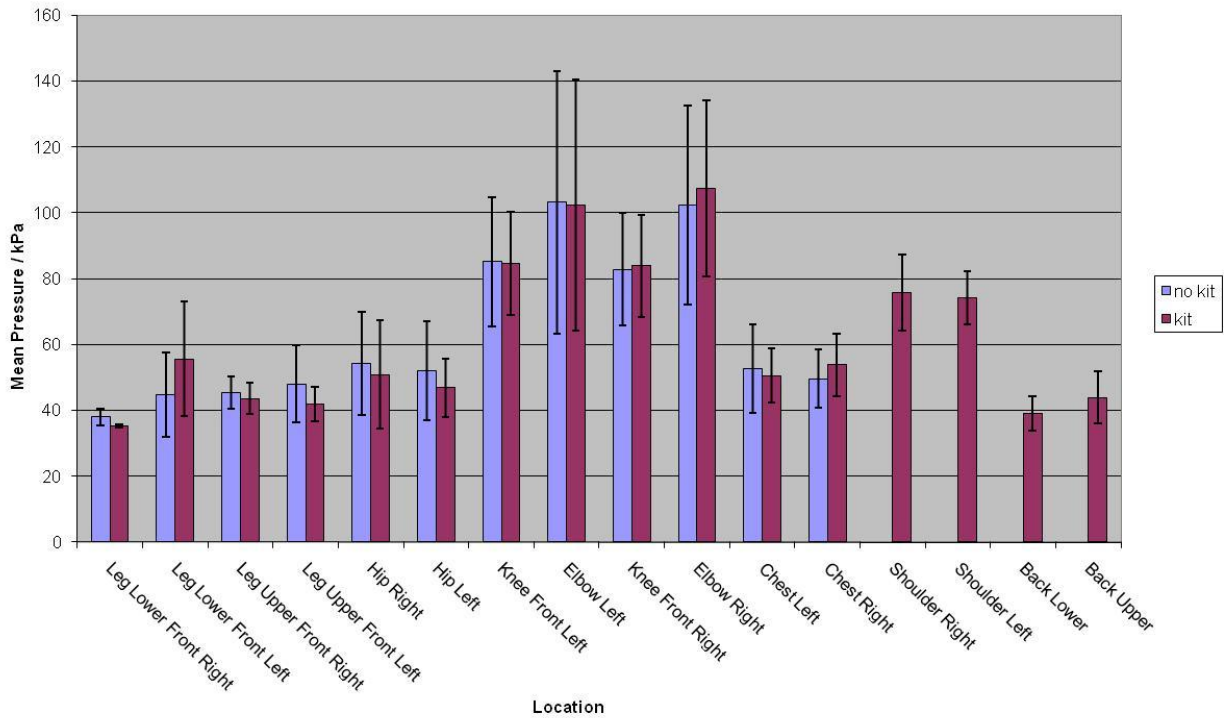

Figure 43 – Mean pressures obtained for the assault exercise performed in the laboratory by Subject A.

Similarly to the assault exercise performed on grassland, the highest mean pressures (and variation) were obtained for the elbows, which were just above 100 kPa. The knees averaged in the region of 85 kPa, and the shoulders in the region of 75 kPa. The remaining locations averaged between 40 kPa and 60 kPa.

Excluding the ‘leg lower front left’, the right elbow and right side of the chest, the webbing and back pack had no impact on the mean pressures; overall, an average reduction of 1% was observed (Table 14).

**UNCLASSIFIED**

	<i>Mean Pressure / kPa</i>	<i>SD</i>	<i>Kit</i>	<i>Change due to kit / %</i>
<b>Leg Lower Front Right</b>	38	2.5	No	
	35.3	0.4	Yes	-7.1
<b>Leg Lower Front Left</b>	44.8	12.9	No	
	55.6	17.4	Yes	24.1
<b>Leg Upper Front Right</b>	45.3	4.9	No	
	43.5	4.7	Yes	-4.0
<b>Leg Upper Front Left</b>	48	11.6	No	
	41.9	5.2	Yes	-12.7
<b>Hip Right</b>	54.3	15.5	No	
	50.8	16.4	Yes	-6.4
<b>Hip Left</b>	52	15	No	
	46.9	8.8	Yes	-9.8
<b>Knee Front Left</b>	85.1	19.5	No	
	84.7	15.7	Yes	-0.5
<b>Elbow Left</b>	103.1	39.8	No	
	102.3	38.1	Yes	-0.8
<b>Knee Front Right</b>	82.8	17.1	No	
	83.9	15.4	Yes	1.3
<b>Elbow Right</b>	102.3	30.3	No	
	107.4	26.7	Yes	5.0
<b>Chest Left</b>	52.8	13.5	No	
	50.5	8.3	Yes	-4.4
<b>Chest Right</b>	49.6	8.9	No	
	53.9	9.5	Yes	8.7
<b>Shoulder Left</b>	-		No	
	74.1	8.1	Yes	-
<b>Shoulder Right</b>	-		No	
	75.8	11.5	Yes	-
<b>Back Lower</b>	-		No	
	39.1	5.1	Yes	-
<b>Back Upper</b>	-		No	
	43.9	7.9	Yes	-
<b>Average %</b>				<b>-1</b>

Table 14 – Mean pressures, and standard deviations of the mean (SD), calculated for the assault exercise performed in the laboratory by Subject A.

5.2.2.2 Peak Pressure

The peak pressures recorded during the assault exercise, performed in the laboratory by Subject A, are displayed in Figure 44 and Table 15.

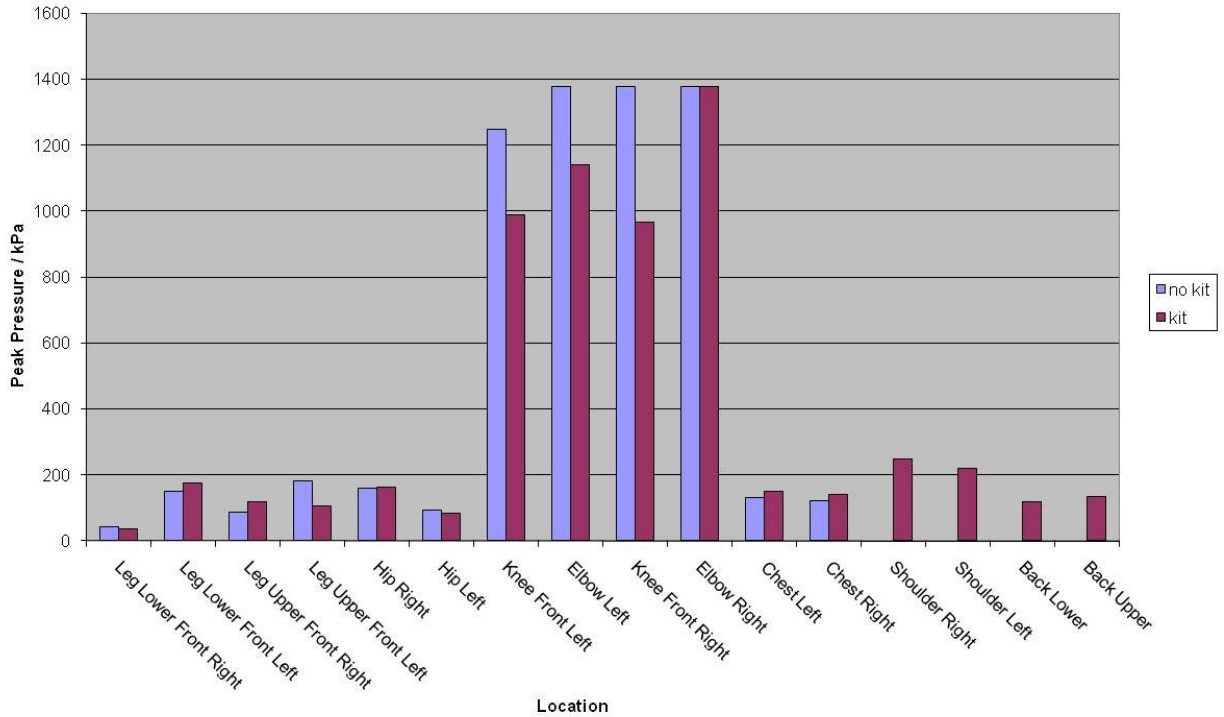

Figure 44 – Peak pressures recorded for the assault exercise performed in the laboratory by Subject A.

Peak pressures obtained for the knees and elbows were all in the mega-Pascal range, with the right knee and both elbows achieving the sensor’s upper calibration limit of 1379 kPa. However, the highest peak pressures were observed when the exercise was performed without the additional kit; in fact overall there was an average reduction of 5% in the peak pressures when the exercise was performed with the additional webbing and back pack.

Excluding the pressures obtained for the right and left shoulders, which were 220 kPa and 249 kPa, respectively, the peak pressures obtained at the other locations were less than 200 kPa, similar to the results obtained on grassland.

**UNCLASSIFIED**

	<i>Peak Pressure / kPa</i>	<i>Kit</i>	<i>Change due to kit / %</i>
<b>Leg Lower Front Right</b>	42.2	No	-14.2
	36.2	Yes	
<b>Leg Lower Front Left</b>	148.9	No	17.7
	175.3	Yes	
<b>Leg Upper Front Right</b>	87.9	No	35.4
	119	Yes	
<b>Leg Upper Front Left</b>	181.7	No	-41.4
	106.4	Yes	
<b>Hip Right</b>	160.8	No	1.2
	162.7	Yes	
<b>Hip Left</b>	94.1	No	-10.6
	84.1	Yes	
<b>Knee Front Left</b>	1249	No	-20.8
	989	Yes	
<b>Elbow Left</b>	1379	No	-17.4
	1139.5	Yes	
<b>Knee Front Right</b>	1379	No	-29.9
	966.7	Yes	
<b>Elbow Right</b>	1379	No	-
	1379	Yes	
<b>Chest Left</b>	131.6	No	13.0
	148.7	Yes	
<b>Chest Right</b>	121.3	No	16.0
	140.7	Yes	
<b>Shoulder Left</b>	-	No	-
	220.2	Yes	
<b>Shoulder Right</b>	-	No	-
	248.5	Yes	
<b>Back Lower</b>	-	No	-
	119.2	Yes	
<b>Back Upper</b>	-	No	-
	134.5	Yes	
<b>Average %</b>			<b>-5</b>

Table 15 – Peak pressures recorded for the assault exercise performed in the laboratory by Subject A.

The distributions for the peak pressures obtained for the right elbow are displayed in Figure 45. As observed in all the instances above, the maximum peak pressure (1379 kPa) occurred only for a very small fraction of the total duration of the exercise (i.e. less than 0.5%). The majority of peak pressures were at or below 350 kPa when performing

the exercise either with or without the additional kit. Similar findings were also observed for the left elbow and left and right knees (Appendix C).

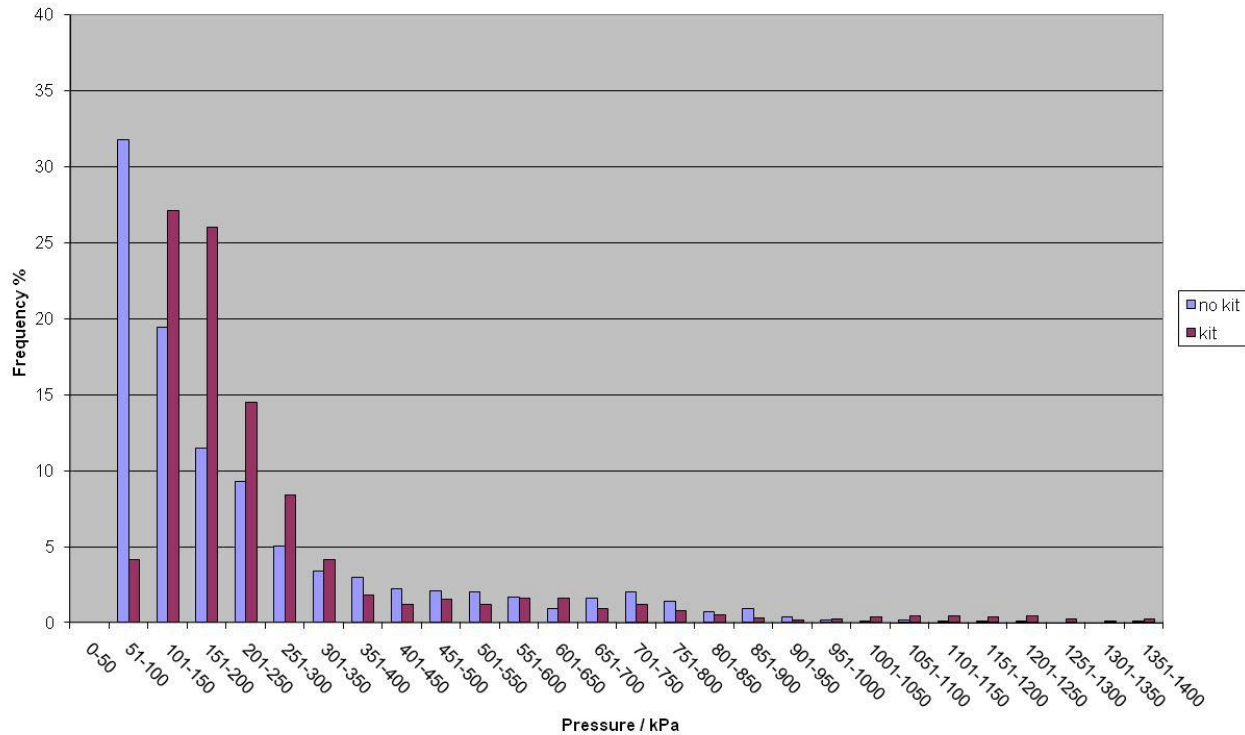

Figure 45 – Peak pressure distribution recorded for the right elbow during the assault exercise performed in the laboratory by Subject A.

**5.2.3 Subject B (Grassland)**

**5.2.3.1 Mean Pressure**

The mean pressures obtained for the assault exercise, performed on grassland for Subject B, are shown below in Figure 46 and Table 16.

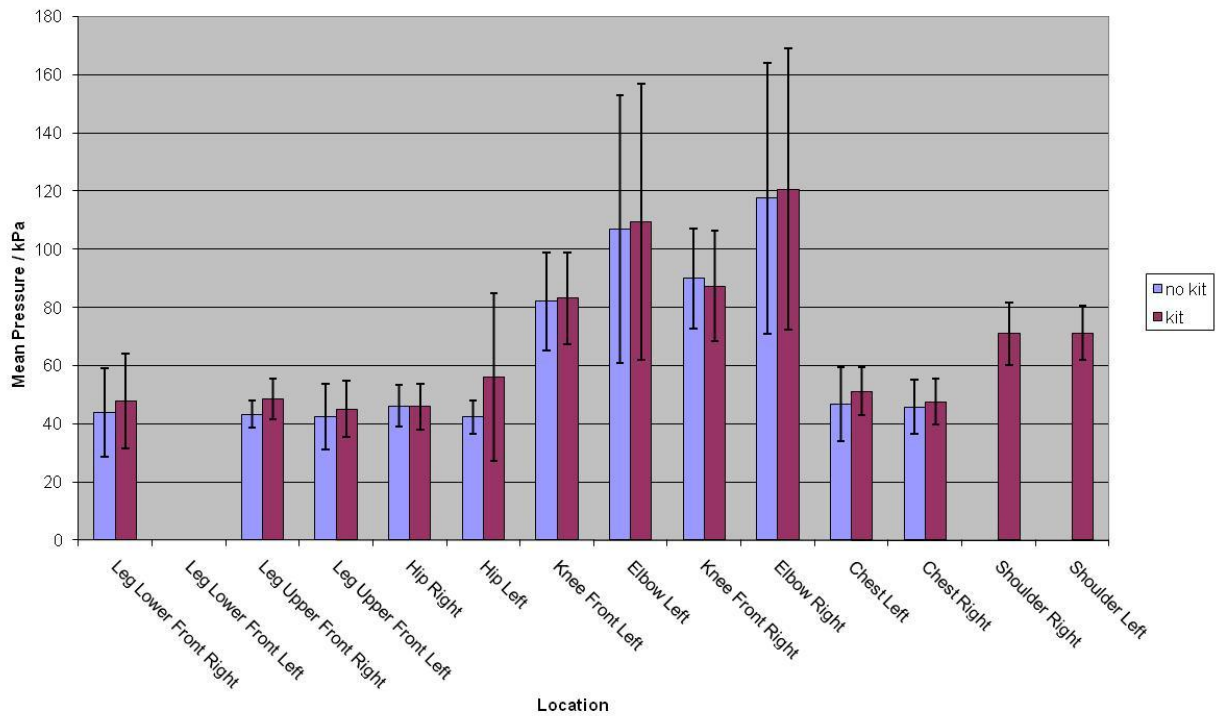

Figure 46 – Mean pressures obtained for the assault exercise performed on grassland by Subject B.

These results were very similar to those obtained for Subject A (Figure 40). The mean pressures obtained for the elbows were between 107 kPa to 120 kPa, the knees were around 80 kPa, the shoulders 71 kPa and the remaining locations were between 40 kPa and 60 kPa.

Apart from the right hip and right knee, the mean pressures obtained when the exercise was performed with kit were slightly higher compared to the exercise performed without kit. Overall, there was an average increase of 7% in the mean pressures when the additional kit was worn; the largest difference was measured for the left hip where an increase of 33% was observed.

**UNCLASSIFIED**

	<i>Mean Pressure / kPa</i>	<i>SD</i>	<i>Kit</i>	<i>Change due to kit / %</i>
<b>Leg Lower Front Right</b>	43.7	15.2	No	9.4
	47.8	16.3	Yes	
<b>Leg Lower Front Left</b>	< 34.5	-	No	-
	< 34.5	-	Yes	
<b>Leg Upper Front Right</b>	43.3	4.6	No	12.2
	48.6	7	Yes	
<b>Leg Upper Front Left</b>	42.6	11.3	No	5.9
	45.1	9.8	Yes	
<b>Hip Right</b>	46.1	7.1	No	-0.4
	45.9	8	Yes	
<b>Hip Left</b>	42.3	5.8	No	32.9
	56.2	28.8	Yes	
<b>Knee Front Left</b>	82.1	16.9	No	1.3
	83.2	15.8	Yes	
<b>Elbow Left</b>	107	45.9	No	2.3
	109.5	47.6	Yes	
<b>Knee Front Right</b>	89.9	17.3	No	-2.9
	87.3	18.9	Yes	
<b>Elbow Right</b>	117.5	46.6	No	2.7
	120.7	48.4	Yes	
<b>Chest Left</b>	46.8	12.6	No	9.4
	51.2	8.1	Yes	
<b>Chest Right</b>	45.7	9.4	No	4.2
	47.6	7.9	Yes	
<b>Shoulder Left</b>	-		No	-
	71.2	9.3	Yes	
<b>Shoulder Right</b>	-		No	-
	71	10.8	Yes	
<b>Back Lower</b>	-		No	-
	-		Yes	
<b>Back Upper</b>	-		No	-
	-		Yes	
<b>Average %</b>				<b>7</b>

Table 16 – Mean pressures, and standard deviations of the mean (SD), calculated for the assault exercise performed on grassland by Subject B.

5.2.3.2 Peak Pressure

The peak pressure values recorded during the assault exercise, performed on grassland by Subject B, are shown in Figure 47 and Table 17.

As for Subject A, the highest peak pressures were obtained for the knees and elbows. However, the peak pressures obtained for the right knee (both with and without additional kit) and left knee without the additional kit were all below 1 MPa.

For the remaining locations the peak pressures were generally less than 200 kPa, with the exception of the ‘leg lower front right’ and left hip, both when the additional kit was worn.

Performing the exercise with the additional kit caused an average increase in the recorded peak pressures of 55%; the largest increase of 321% was observed for the left hip.

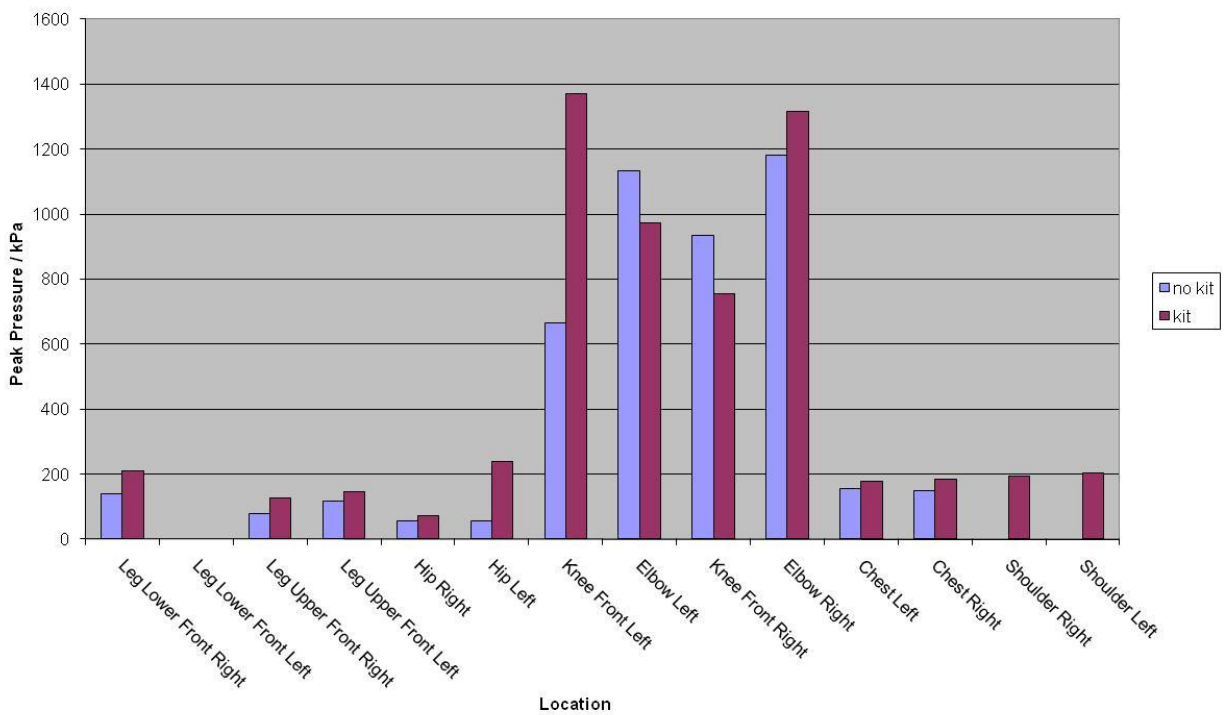

Figure 47 – Maximum pressures recorded for the assault exercise performed on grassland by Subject B.

**UNCLASSIFIED**

	<i>Peak Pressure / kPa</i>	<i>Kit</i>	<i>Change due to kit / %</i>
<b>Leg Lower Front Right</b>	139	No	51.6
	210.7	Yes	
<b>Leg Lower Front Left</b>	< 34.5	No	-
	< 34.5	Yes	
<b>Leg Upper Front Right</b>	79.7	No	59.7
	127.3	Yes	
<b>Leg Upper Front Left</b>	116.9	No	24.9
	146	Yes	
<b>Hip Right</b>	57.4	No	23.9
	71.1	Yes	
<b>Hip Left</b>	56.4	No	320.7
	237.3	Yes	
<b>Knee Front Left</b>	663.9	No	106.2
	1369	Yes	
<b>Elbow Left</b>	1133.2	No	-14.1
	973.4	Yes	
<b>Knee Front Right</b>	934	No	-19.1
	755.4	Yes	
<b>Elbow Right</b>	1181.3	No	11.4
	1315.4	Yes	
<b>Chest Left</b>	157	No	13.5
	178.2	Yes	
<b>Chest Right</b>	148.2	No	25.2
	185.6	Yes	
<b>Shoulder Left</b>	-	No	-
	202.5	Yes	
<b>Shoulder Right</b>	-	No	-
	194.2	Yes	
<b>Back Lower</b>	-	No	-
	-	Yes	
<b>Back Upper</b>	-	No	-
	-	Yes	
<b>Average %</b>			<b>55</b>

Table 17 – Peak pressures recorded for the assault exercise performed on grassland by Subject B.

The distributions of peak pressures for the right elbow are displayed in Figure 48. The majority of peak pressures recorded were at or below 150 kPa. However, approximately 5% fell between 551 kPa and 600 kPa, both with and without the additional kit. Similar results were obtained for the left elbow and left and right knees (Appendix C).

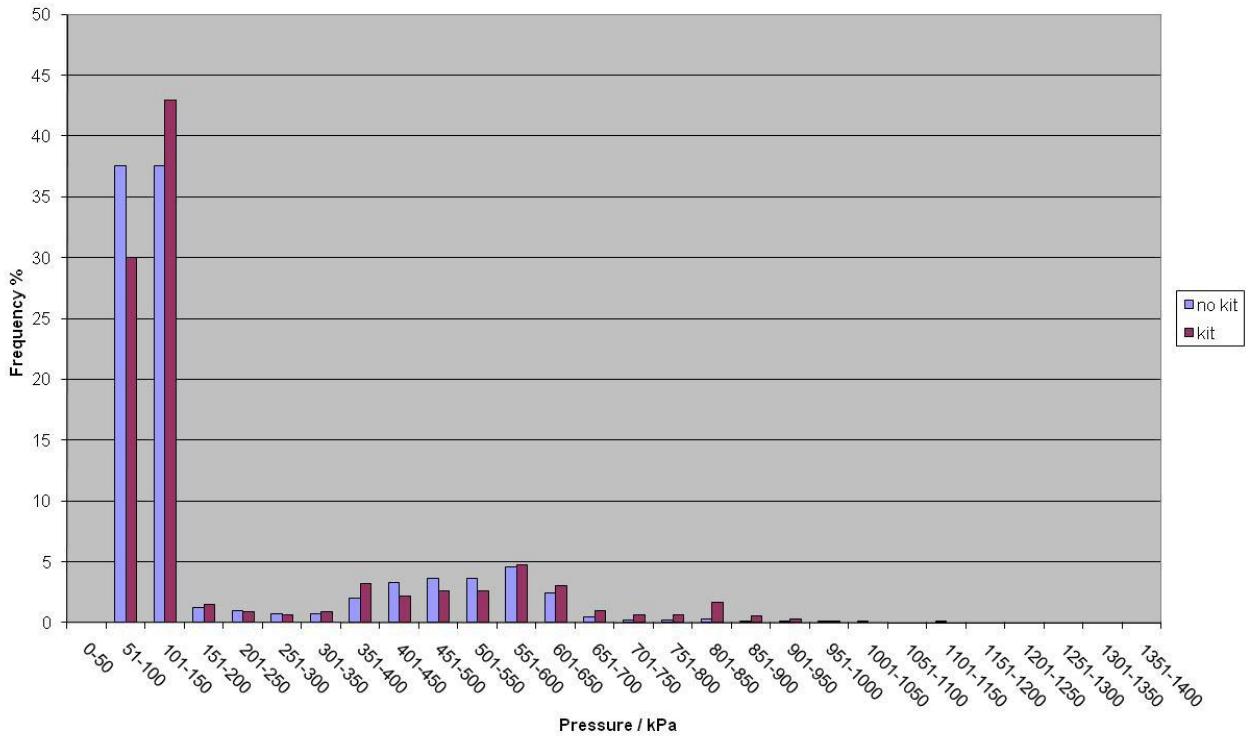

Figure 48 – Peak pressure distribution recorded for the right elbow during the assault exercise performed on grassland by Subject B.

5.2.4 Subject B (Laboratory)

5.2.4.1 Mean Pressure

The mean pressures obtained for the assault exercise, performed in the laboratory by Subject B, are displayed in Figure 49 and Table 18.

Mean pressure values were not obtained for the shoulders or back regions owing to time constraints.

The results obtained in the laboratory are fairly consistent with the results obtained on the grassland (Figure 46); however, performing the exercises with the additional kit had less of an impact. The overall effect of performing the exercise with the webbing and back pack was a 1% reduction in the mean pressure (Table 18).

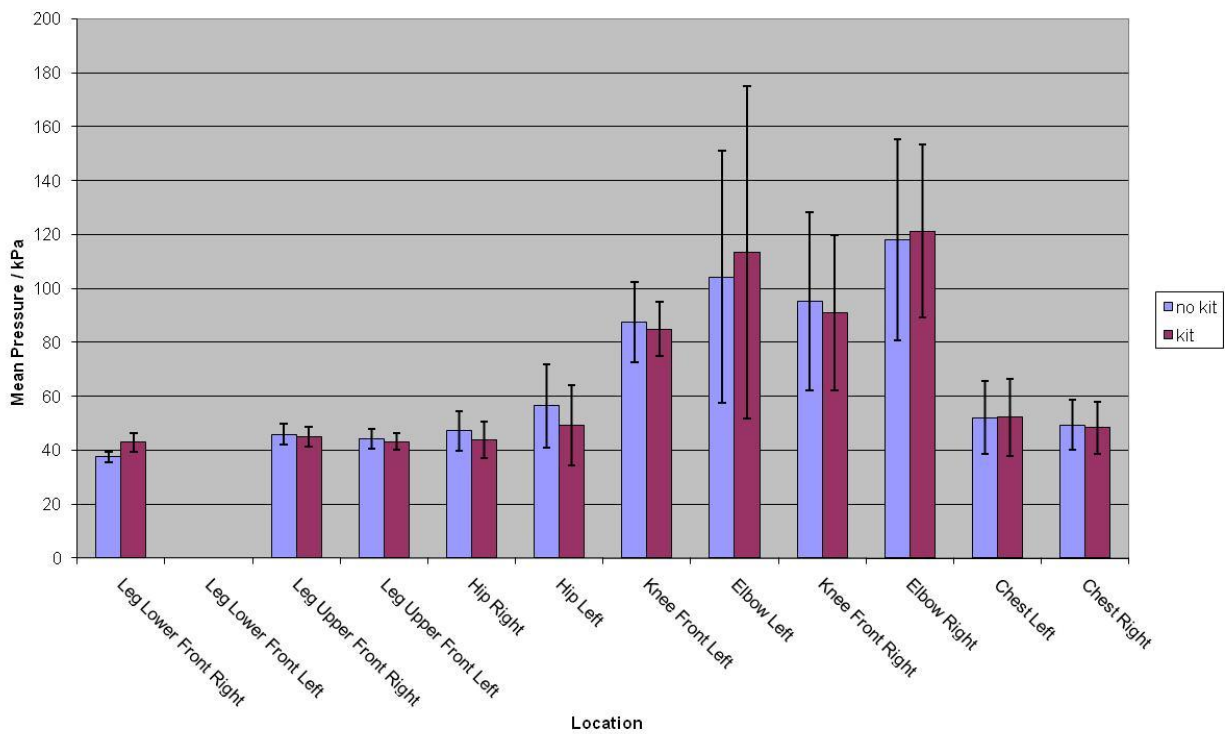

Figure 49 – Mean pressures obtained for the assault exercise performed in the laboratory by Subject B.

**UNCLASSIFIED**

	<i>Mean Pressure / kPa</i>	<i>SD</i>	<i>Kit</i>	<i>Change due to kit / %</i>
<b>Leg Lower Front Right</b>	37.5	2.1	No	14.4
	42.9	3.4	Yes	
<b>Leg Lower Front Left</b>	<34.5	-	No	-
	<34.5	-	Yes	
<b>Leg Upper Front Right</b>	46	4	No	-2.2
	45	3.5	Yes	
<b>Leg Upper Front Left</b>	44.2	3.7	No	-2.3
	43.2	3.1	Yes	
<b>Hip Right</b>	47.2	7.3	No	-7.4
	43.7	6.8	Yes	
<b>Hip Left</b>	56.5	15.4	No	-13.1
	49.1	14.8	Yes	
<b>Knee Front Left</b>	87.4	14.8	No	-2.7
	85	10.2	Yes	
<b>Elbow Left</b>	104.2	46.7	No	8.8
	113.4	61.7	Yes	
<b>Knee Front Right</b>	95.4	33.1	No	-4.6
	91	28.9	Yes	
<b>Elbow Right</b>	118.1	37.2	No	2.8
	121.4	32.1	Yes	
<b>Chest Left</b>	52	13.5	No	0.4
	52.2	14.2	Yes	
<b>Chest Right</b>	49.3	9.3	No	-2.0
	48.3	9.5	Yes	
<b>Shoulder Left</b>	-	-	No	-
	-	-	Yes	
<b>Shoulder Right</b>	-	-	No	-
	-	-	Yes	
<b>Back Lower</b>	-	-	No	-
	-	-	Yes	
<b>Back Upper</b>	-	-	No	-
	-	-	Yes	
<b>Average %</b>				<b>-1</b>

Table 18 – Mean pressures, and associated standard deviations (SD) obtained for the assault exercise performed in the laboratory by Subject B.

5.2.4.2 Peak Pressure

The peak pressures recorded during the assault exercise performed in the laboratory are shown in Figure 50 and Table 19.

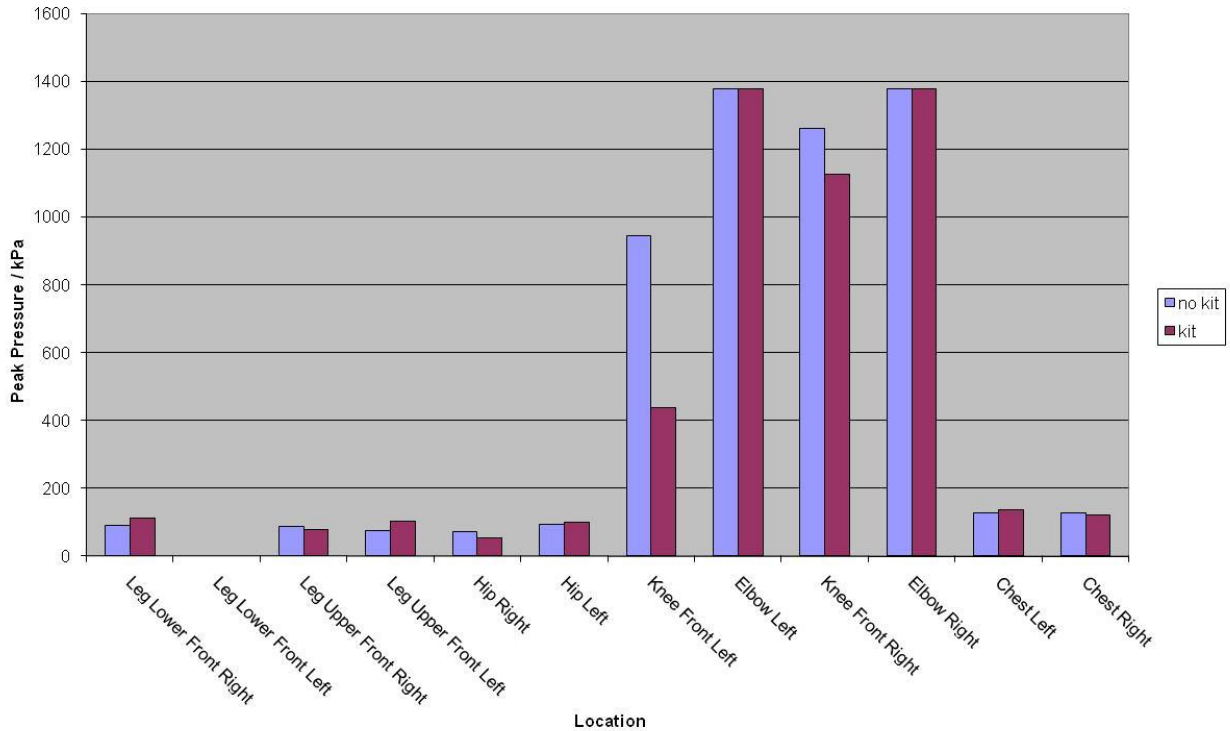

Figure 50 – Peak pressures recorded for the assault exercise performed in the laboratory by Subject B.

The trends are very similar to those observed from the assault exercise conducted on grassland. The right knee and both elbows exhibited peak pressures greater than 1 MPa, with both elbows reaching the sensor’s upper calibration limit of 1379 kPa. When performing the exercise with the additional kit, the left knee however, displayed a relatively low peak pressure reading of 437 kPa, which was 54% lower than the value obtained for the same knee without any additional kit being worn (Table 19).

The peak pressures recorded for the other locations were all below 200 kPa.

Performing the exercise with the additional webbing and back pack had the biggest impact on the ‘leg upper front left’ where an increase in the peak pressure of approximately 37% was observed. Overall, an average reduction was observed in the peak pressure values of 3%.

**UNCLASSIFIED**

	<i>Peak Pressure / kPa</i>	<i>Kit</i>	<i>Changedue to kit / %</i>
<b>Leg Lower Front Right</b>	92	No	21.3
	111.6	Yes	
<b>Leg Lower Front Left</b>	<34.5	No	-
	<34.5	Yes	
<b>Leg Upper Front Right</b>	86.4	No	-9.8
	77.9	Yes	
<b>Leg Upper Front Left</b>	75.2	No	36.6
	102.7	Yes	
<b>Hip Right</b>	70.8	No	-22.6
	54.8	Yes	
<b>Hip Left</b>	94.4	No	4.2
	98.4	Yes	
<b>Knee Front Left</b>	944	No	-53.7
	436.7	Yes	
<b>Elbow Left</b>	1379	No	-
	1379	Yes	
<b>Knee Front Right</b>	1260.7	No	-10.6
	1126.8	Yes	
<b>Elbow Right</b>	1379	No	-
	1379	Yes	
<b>Chest Left</b>	128	No	7.2
	137.2	Yes	
<b>Chest Right</b>	127.4	No	-3.9
	122.4	Yes	
<b>Shoulder Left</b>	-	No	-
	-	Yes	
<b>Shoulder Right</b>	-	No	-
	-	Yes	
<b>Back Lower</b>	-	No	-
	-	Yes	
<b>Back Upper</b>	-	No	-
	-	Yes	
<b>Average %</b>			<b>-3</b>

Table 19 – Peak pressures recorded for the assault exercise performed in the laboratory by Subject B.

The distributions of peak pressures obtained for the right elbow are shown in Figure 51. In this instance, the majority of peak pressures were at or below 300 kPa without kit and 500 kPa with kit; approximately 2% occurred between 1351 kPa and 1379 kPa.

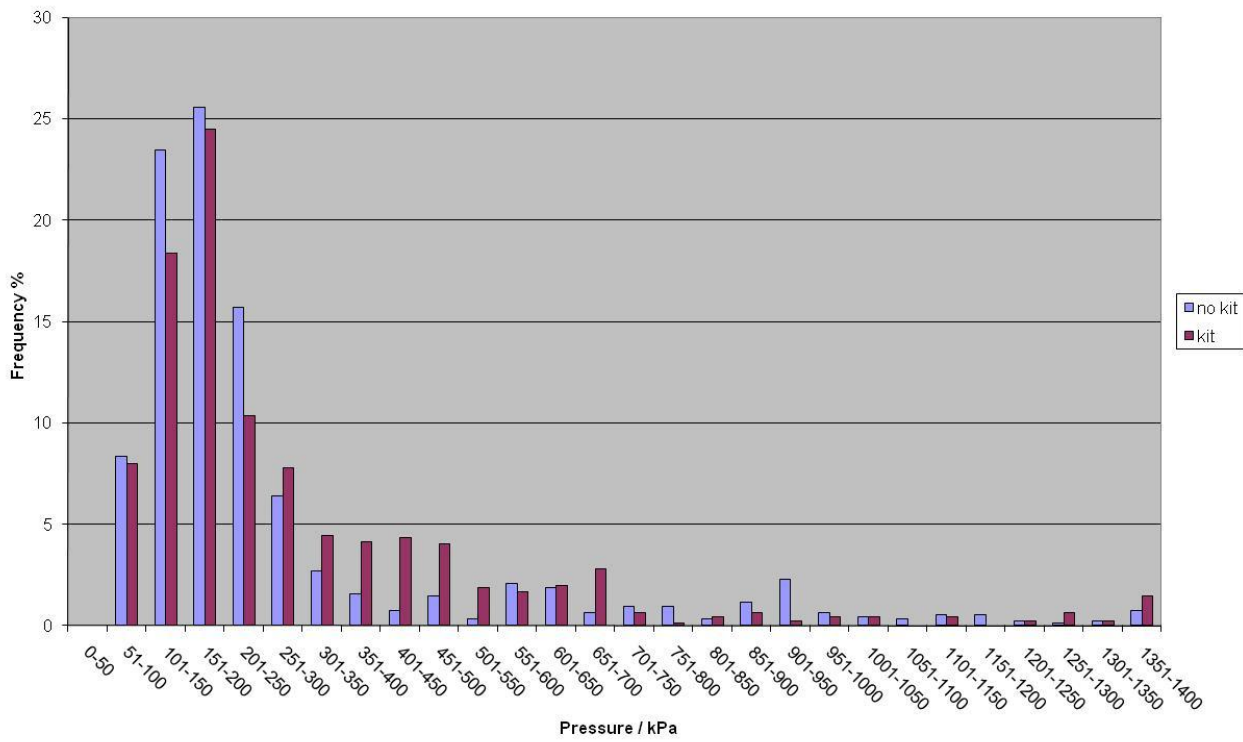

Figure 51 – Peak pressure distribution recorded for the right elbow during the assault exercise performed in the laboratory by Subject B.

**5.2.5 Subject C (Laboratory)**

Owing to poor weather conditions, Subject C performed the activities inside the laboratory only.

**5.2.5.1 Mean Pressure**

The mean pressures calculated for during the assault exercise, performed in the laboratory by Subject C, are shown in Figure 52 and Table 20.

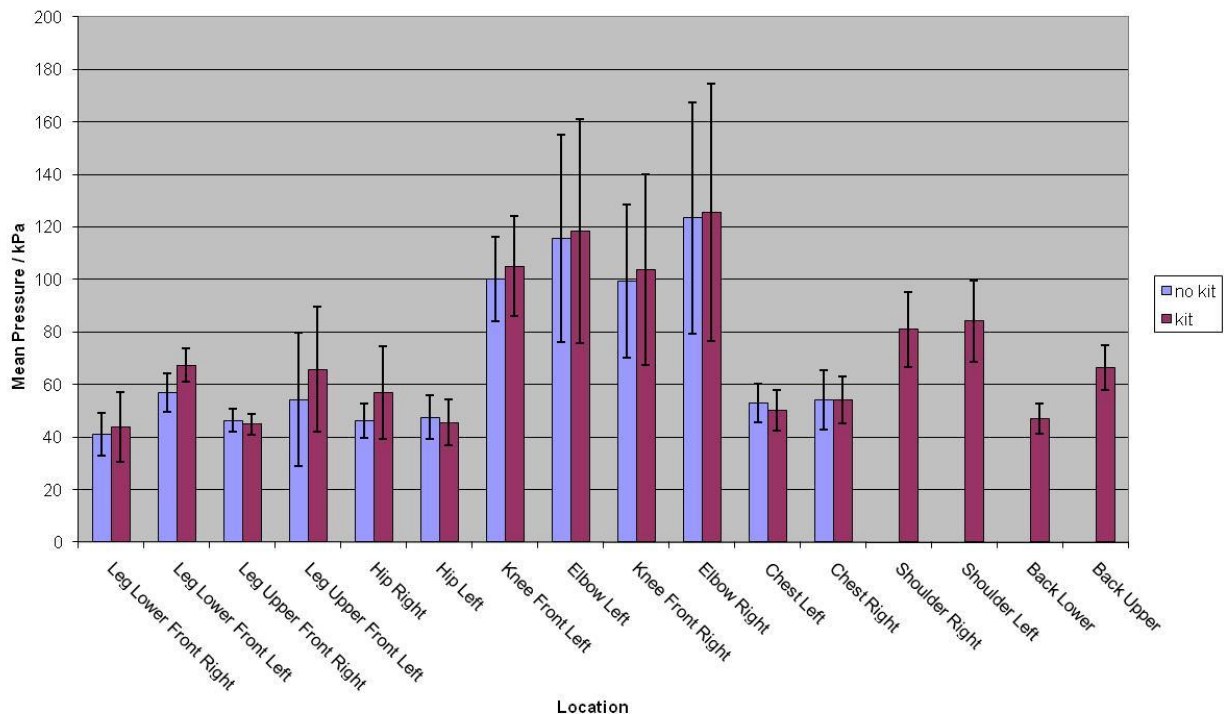

Figure 52 – Mean pressures obtained for the assault exercise performed in the laboratory by Subject C.

These results are fairly consistent with those observed with both Subjects A and B (Figures 43 and 49, respectively). The mean pressures obtained for the knees and elbows were between 100 kPa and 125 kPa, the shoulders were around 80 kPa and the remaining locations were between 40 kPa and 70 kPa.

The largest impact of performing the exercise in the additional kit was for the right hip where an increase of approximately 23% was observed. Overall, an average increase of 6% was observed for the mean pressure when wearing the combat webbing and back pack.

**UNCLASSIFIED**

	<i>Mean Pressure / kPa</i>	<i>SD</i>	<i>Kit</i>	<i>Change due to kit / %</i>
<b>Leg Lower Front Right</b>	40.9	8.1	No	7.3
	43.9	13.4	Yes	
<b>Leg Lower Front Left</b>	56.9	7.3	No	18.3
	67.3	6.4	Yes	
<b>Leg Upper Front Right</b>	46.4	4.5	No	-3.2
	44.9	4	Yes	
<b>Leg Upper Front Left</b>	54.2	25.4	No	21.4
	65.8	23.9	Yes	
<b>Hip Right</b>	46.3	6.5	No	23.1
	57	17.6	Yes	
<b>Hip Left</b>	47.6	8.3	No	-4.4
	45.5	8.8	Yes	
<b>Knee Front Left</b>	100.1	16	No	4.9
	105	19.1	Yes	
<b>Elbow Left</b>	115.7	39.5	No	2.2
	118.3	42.7	Yes	
<b>Knee Front Right</b>	99.3	29	No	4.4
	103.7	36.3	Yes	
<b>Elbow Right</b>	123.4	44.1	No	1.6
	125.4	48.9	Yes	
<b>Chest Left</b>	53	7.2	No	-5.3
	50.2	7.6	Yes	
<b>Chest Right</b>	54.1	11.3	No	-
	54.1	8.8	Yes	
<b>Shoulder Left</b>	-		No	-
	84.1	15.5	Yes	
<b>Shoulder Right</b>	-		No	-
	81	14.4	Yes	
<b>Back Lower</b>	-		No	-
	47	5.9	Yes	
<b>Back Upper</b>	-		No	-
	66.4	8.5	Yes	
<b>Average %</b>				<b>6</b>

Table 20 – Mean pressures, and associated standard deviations (SD) obtained for the assault exercise performed in the laboratory by Subject C.

5.2.5.2 Peak Pressure

The peak pressures obtained during the assault exercise, performed in the laboratory by Subject C, are displayed in Figure 53 and Table 21.

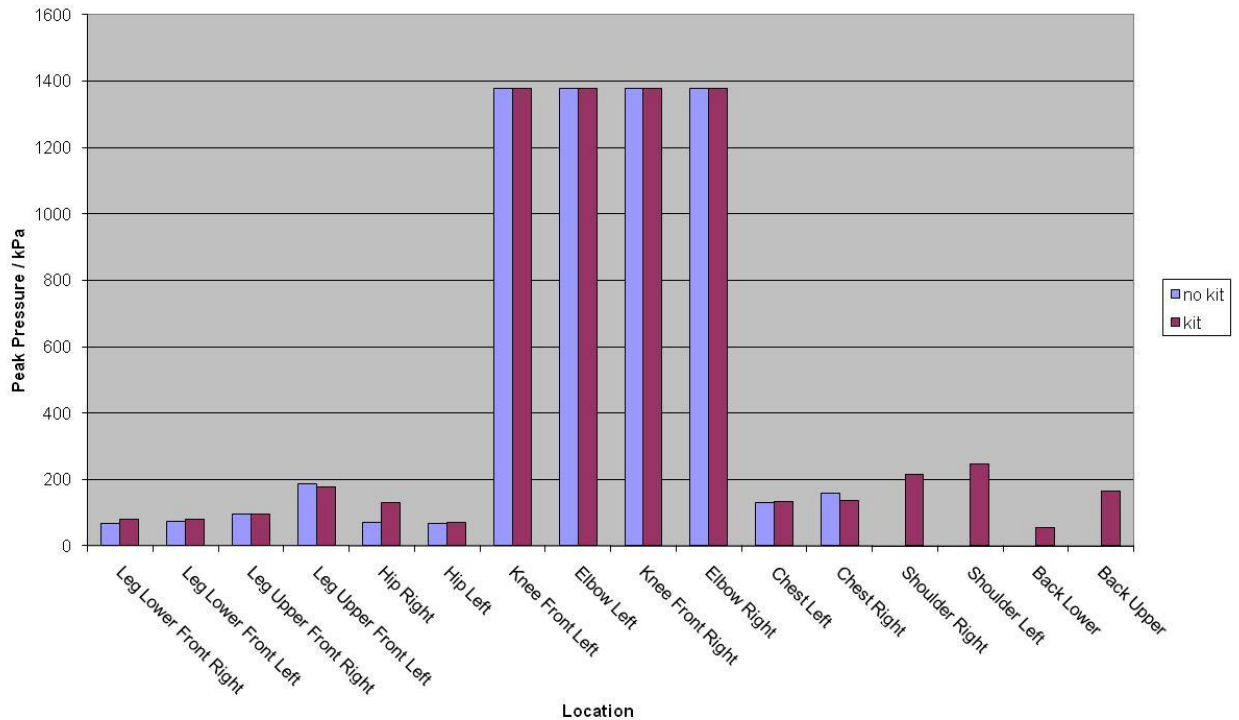

Figure 53 – Peak pressures recorded for the assault exercise performed in the laboratory by Subject C.

As for Subjects A and B, a similar trend was observed, with the highest peak pressures generated at the knees and elbows; in this trial the peak pressures recorded at both knees and elbow exceeded the upper calibration limit of 1379 kPa.

Apart from the shoulders where peak pressures of 246 kPa and 217 kPa were observed, the remaining locations generated peak pressures below 200 kPa, as observed for Subjects A and B.

Overall, an average increase of 12% in the peak pressures was observed for the assault exercise performed with the additional kit; however, this value may have been skewed by the 85% increase found for the right hip (Table 21).

**UNCLASSIFIED**

	<i>Peak Pressure / kPa</i>	<i>Kit</i>	<i>Change due to kit / %</i>
<b>Leg Lower Front Right</b>	66	No	22.3
	80.7	Yes	
<b>Leg Lower Front Left</b>	74.6	No	7.4
	80.1	Yes	
<b>Leg Upper Front Right</b>	97	No	-1.8
	95.3	Yes	
<b>Leg Upper Front Left</b>	186.2	No	-5.2
	176.6	Yes	
<b>Hip Right</b>	69.8	No	85.2
	129.3	Yes	
<b>Hip Left</b>	69	No	3.3
	71.3	Yes	
<b>Knee Front Left</b>	1379	No	-
	1379	Yes	
<b>Elbow Left</b>	1379	No	-
	1379	Yes	
<b>Knee Front Right</b>	1379	No	-
	1379	Yes	
<b>Elbow Right</b>	1379	No	-
	1379	Yes	
<b>Chest Left</b>	131.6	No	2.1
	134.3	Yes	
<b>Chest Right</b>	157.7	No	-13.8
	135.9	Yes	
<b>Shoulder Left</b>	-	No	-
	246.2	Yes	
<b>Shoulder Right</b>	-	No	-
	216.7	Yes	
<b>Back Lower</b>	-	No	-
	55.5	Yes	
<b>Back Upper</b>	-	No	-
	164	Yes	
<b>Average %</b>			<b>12</b>

Table 21 – Peak pressures recorded for the assault exercise performed in the laboratory by Subject C.

The distributions of peak pressures for the right elbow are shown in Figure 54. The majority of peak pressures were at or below 250 kPa both with and without kit. The maximum peak pressure was encountered for approximately 5% of the time without kit and approximately 10% with kit, which was more than for Subjects A and B.

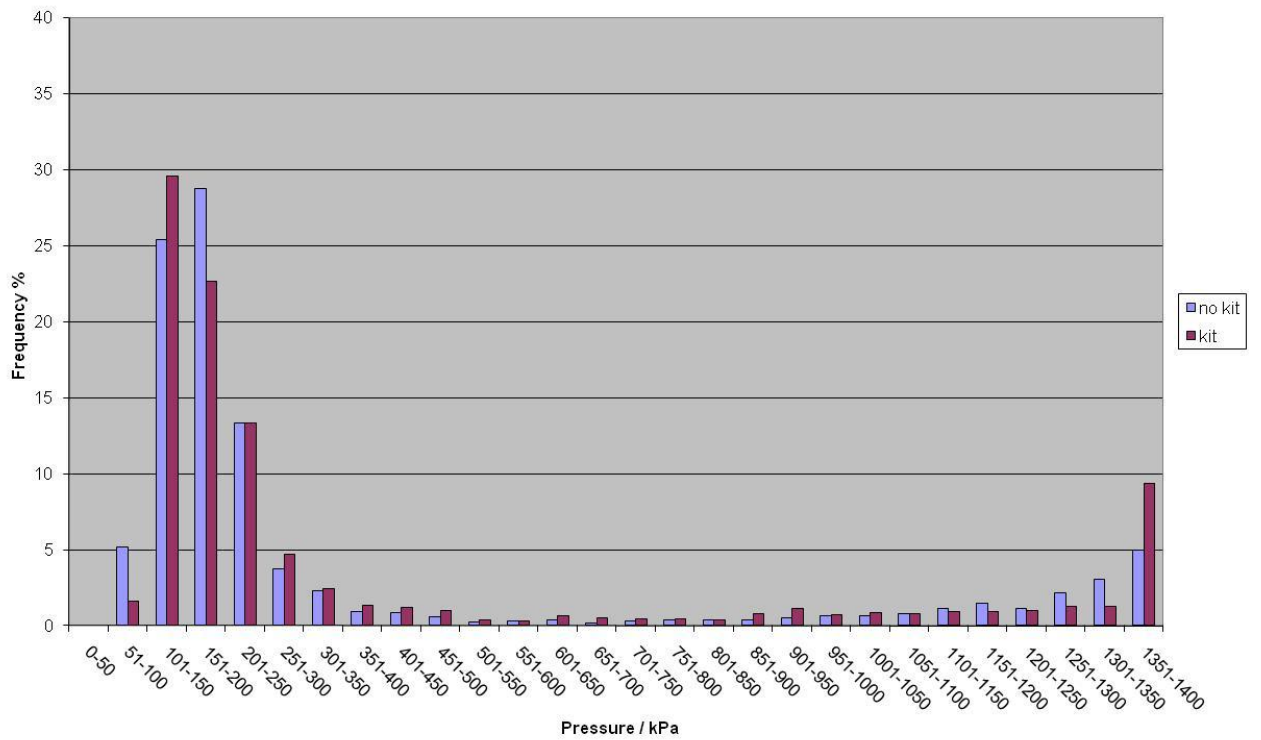

Figure 54 – Peak pressure distribution recorded for the right elbow during the assault exercise performed in the laboratory by Subject C.

**5.3 Leopard Crawl**

**5.3.1 Subject A (Grassland)**

**5.3.1.1 Mean Pressure**

The mean pressures obtained during the leopard crawl, performed on grassland for Subject A, are displayed in Figure 55 and Table 22.

The largest mean pressures were generated at the knees and elbows and were in the region of 100 kPa and 120 kPa. The remaining locations across the body experienced mean pressures between 40 kPa and 60 kPa. Broadly speaking, these mean pressures were fairly consistent with those obtained during the kneeling and assault exercises.

The biggest effect of performing the leopard crawl with the additional webbing and back pack was seen on the right side of the chest where an 11% increase was observed. However, overall, there was no net increase in the mean pressure with added kit.

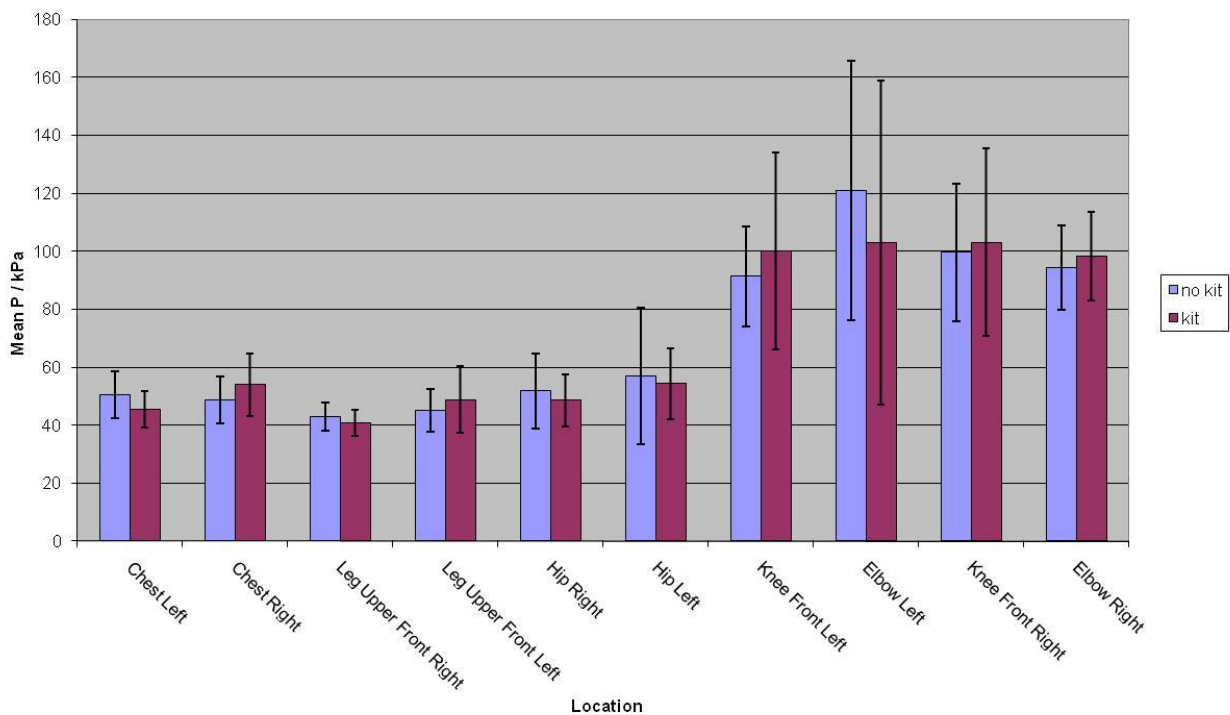

Figure 55 – Mean pressures obtained for the leopard crawl performed on grassland by Subject A.

	<i>Mean Pressure / kPa</i>	<i>SD</i>	<i>Kit</i>	<i>Change due to kit / %</i>
<b>Leg Upper Front Right</b>	43	4.9	No	-5.1
	40.8	4.6	Yes	
<b>Leg Upper Front Left</b>	45.1	7.3	No	8.4
	48.9	11.6	Yes	
<b>Hip Right</b>	51.8	13.1	No	-6.4
	48.5	8.9	Yes	
<b>Hip Left</b>	57	23.4	No	-4.7
	54.3	12.1	Yes	
<b>Knee Front Left</b>	91.4	17.2	No	9.5
	100.1	34	Yes	
<b>Elbow Left</b>	121	44.7	No	-14.8
	103.1	55.8	Yes	
<b>Knee Front Right</b>	99.6	23.6	No	3.5
	103.1	32.4	Yes	
<b>Elbow Right</b>	94.3	14.7	No	4.2
	98.3	15.2	Yes	
<b>Chest Left</b>	50.5	8	No	-9.9
	45.5	6.2	Yes	
<b>Chest Right</b>	48.6	8.1	No	11.3
	54.1	10.8	Yes	
<b>Average %</b>				<b>0</b>

Table 22 – Mean pressure, and associated standard deviations (SD) for the leopard crawl performed on grassland by Subject A.

### 5.3.1.2 Peak Pressure

The peak pressures obtained during the leopard crawl, performed on grassland by Subject A, are displayed in Figure 56 and Table 23.

The left elbow and right knee produced peak pressures that achieved the sensor's upper calibration limit of 1379 kPa, whereas the right elbow and left knee produced peak pressures below 1 MPa.

Peak pressures generated at the chest, upper legs and hips all fell below 200 kPa.

Performing the exercise in additional kit had the biggest impact for the left knee where an increase in the peak pressure of 64% was observed. Overall, the effect of the additional kit increased the peak pressures by 10%.

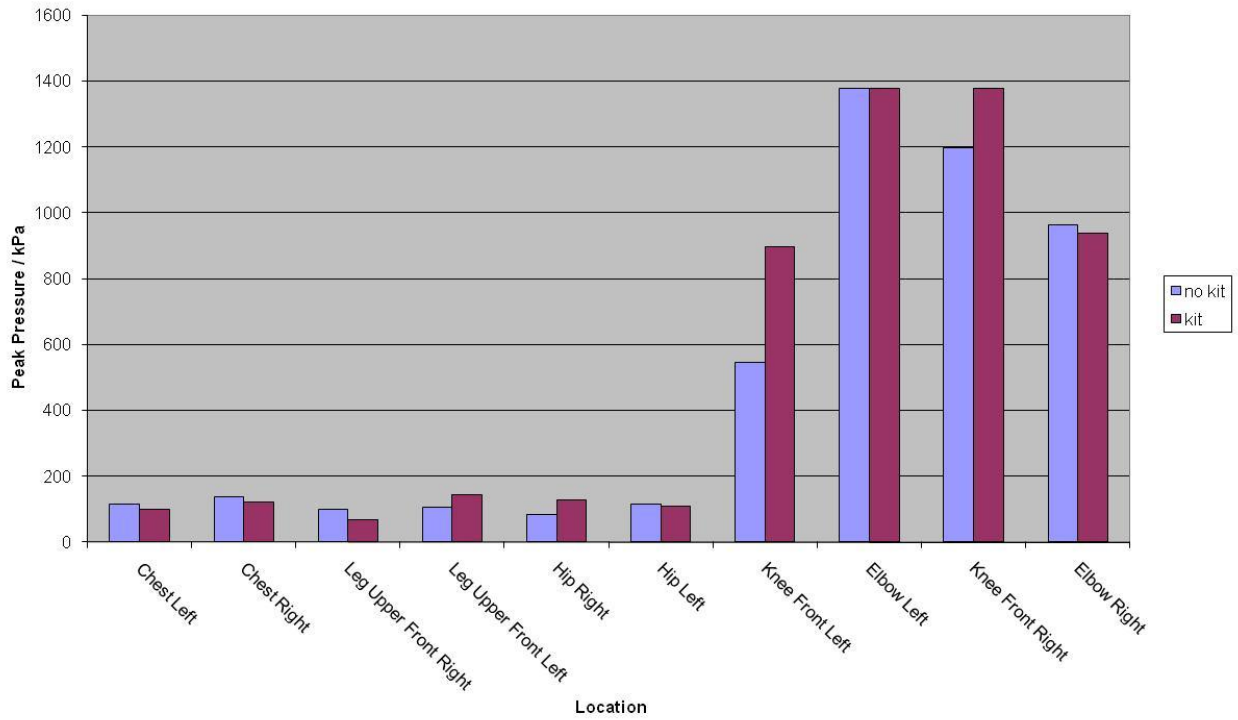

Figure 56 – Peak pressures obtained for the leopard crawl performed on grassland by Subject A.

**UNCLASSIFIED**

	<i>Peak Pressure / kPa</i>	<i>Kit</i>	<i>Change due to kit / %</i>
<b>Leg Upper Front Right</b>	99	No	-31.3
	68	Yes	
<b>Leg Upper Front Left</b>	106.7	No	33.5
	142.4	Yes	
<b>Hip Right</b>	83.2	No	52.5
	126.9	Yes	
<b>Hip Left</b>	116.3	No	-7.2
	107.9	Yes	
<b>Knee Front Left</b>	546.7	No	64.2
	897.9	Yes	
<b>Elbow Left</b>	1379	No	0.0
	1379	Yes	
<b>Knee Front Right</b>	1198.7	No	15.0
	1379	Yes	
<b>Elbow Right</b>	963	No	-2.5
	939.4	Yes	
<b>Chest Left</b>	115.5	No	-14.0
	99.3	Yes	
<b>Chest Right</b>	137.2	No	-10.3
	123.1	Yes	
<b>Average %</b>			<b>10</b>

Table 23 – Peak pressures recorded for the leopard crawl performed on grassland by Subject A.

The distributions of peak pressures obtained for the right knee during the leopard crawl on grassland are shown in Figure 57. These plots exhibited a similar trend to the rest of the peak pressure distributions observed above. The majority of peak pressures were at or below 250 kPa followed by what appears to be an exponential decrease in the frequency as the pressure range is increased. Similar findings were observed for the left knee and right and left elbows (Appendix C).

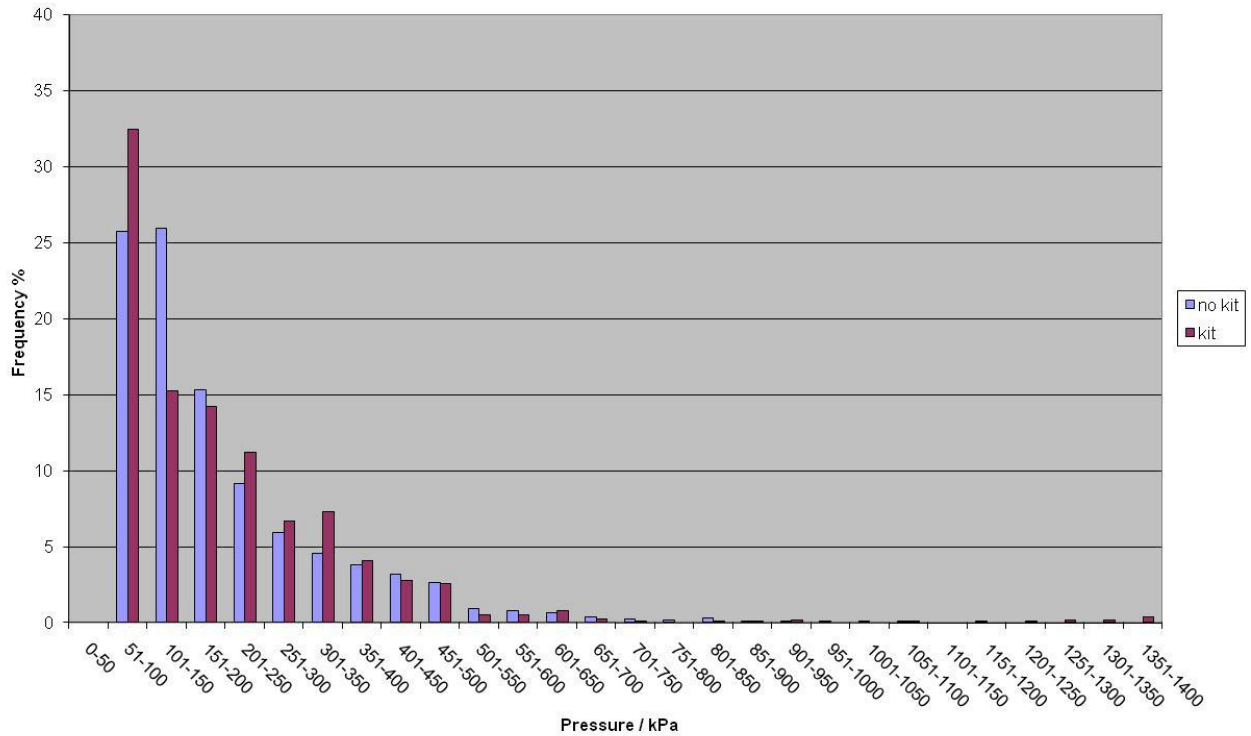

Figure 57 – Peak pressure distribution recorded for the right knee during the leopard crawl performed on grassland by Subject A.

### 5.3.2 Subject A (Laboratory)

#### 5.3.2.1 Mean Pressure

The mean pressures obtained during the leopard crawl, performed in the laboratory for Subject A, are shown in Figure 58 and Table 24.

These results were fairly consistent with the results observed on grassland, with the knees and elbow generating mean pressures in the region of 100 kPa and the remaining locations exhibited pressures between 40 kPa and 60 kPa.

Performing the exercise with the additional kit increased the mean pressures obtained at the knees and elbows by 14% to 18%. Overall, an average increase in the mean pressures of 4% was observed when the exercise was performed with the additional combat webbing and back pack.

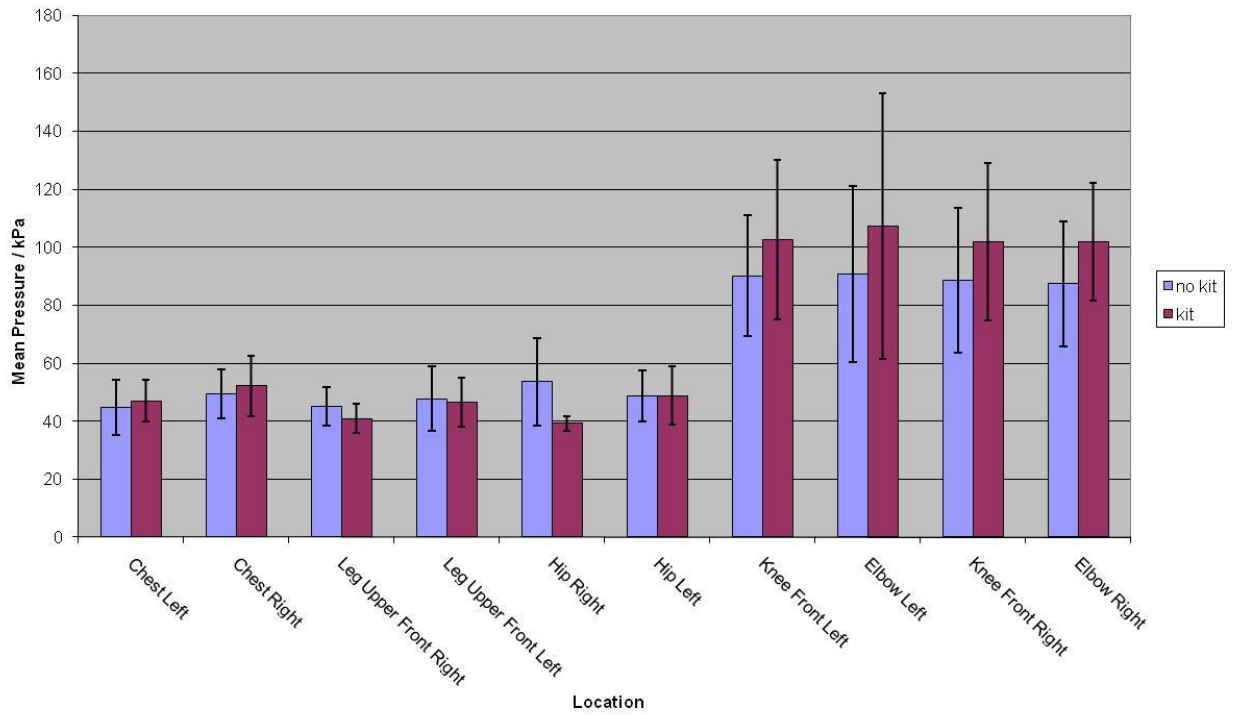

Figure 58 – Mean pressures obtained for the leopard crawl performed in the laboratory by Subject A.

**UNCLASSIFIED**

	<i>Mean Pressure / kPa</i>	<i>SD</i>	<i>Kit</i>	<i>Change due to kit / %</i>
<b>Leg Upper Front Right</b>	45	6.6	No	-9.1
	40.9	5.1	Yes	
<b>Leg Upper Front Left</b>	47.7	11.2	No	-2.3
	46.6	8.4	Yes	
<b>Hip Right</b>	53.6	15.1	No	-26.9
	39.2	2.5	Yes	
<b>Hip Left</b>	48.6	8.8	No	0.6
	48.9	9.9	Yes	
<b>Knee Front Left</b>	90.2	20.9	No	13.6
	102.5	27.4	Yes	
<b>Elbow Left</b>	90.9	30.3	No	17.9
	107.2	45.9	Yes	
<b>Knee Front Right</b>	88.6	25.1	No	15.1
	102	27.1	Yes	
<b>Elbow Right</b>	87.4	21.5	No	16.7
	102	20.3	Yes	
<b>Chest Left</b>	44.6	9.5	No	5.4
	47	7.3	Yes	
<b>Chest Right</b>	49.4	8.5	No	5.5
	52.1	10.5	Yes	
<b>Average %</b>				<b>4</b>

Table 24 – Mean pressures, and associated standard deviations (SD) for the leopard crawl performed in the laboratory by Subject A.

**5.3.2.2 Peak Pressure**

The peak pressures obtained during the leopard crawl, performed in the laboratory by Subject A, are displayed in Figure 59 and Table 25.

The knees and elbow generated peak pressures above 1 MPa, with the left and right elbows and right knee all achieving the 1379 kPa upper limit.

Peak pressures generated at the chest, upper legs and hips all fell below 200 kPa, as observed for the exercise performed on grassland (Figure 56).

Apart from for the left hip, performing the exercise with the additional kit reduced the peak pressures recorded; overall there was a reduction in the peak pressures of 22%.

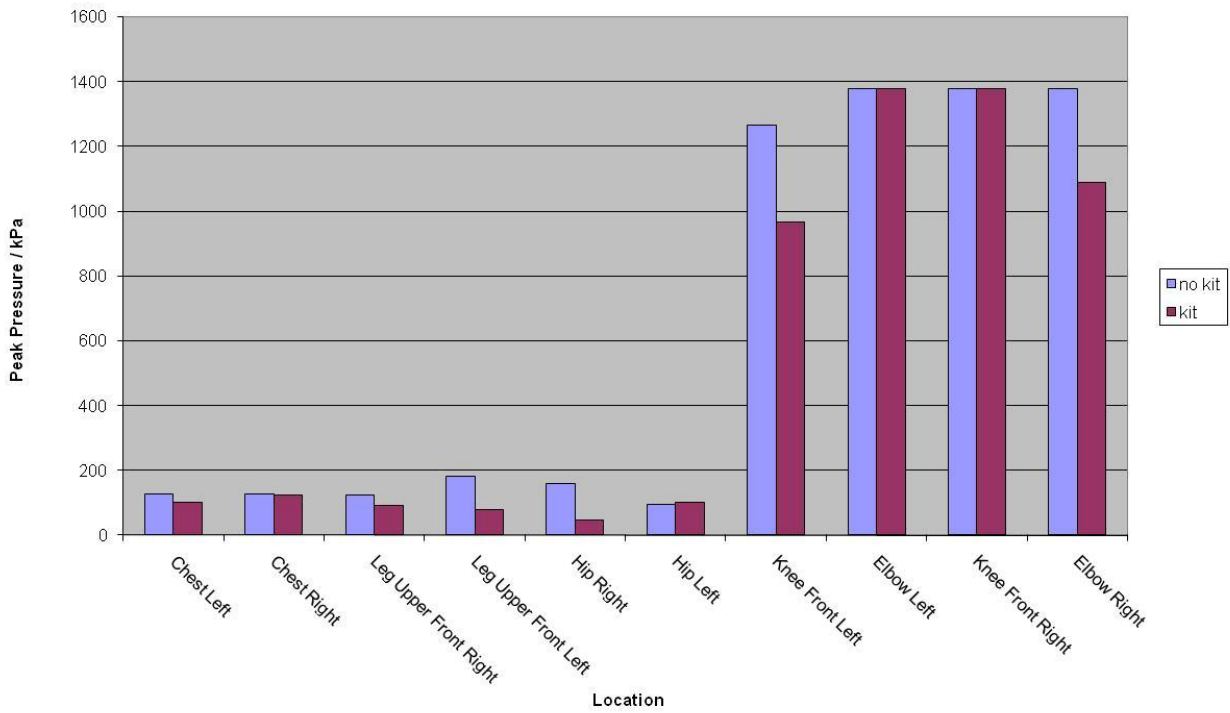

Figure 59 – Peak pressures obtained for the leopard crawl performed in the laboratory by Subject A.

**UNCLASSIFIED**

	<i>Peak Pressure / kPa</i>	<i>Kit</i>	<i>Change due to kit / %</i>
<b>Leg Upper Front Right</b>	124.6	No	-27.5
	90.3	Yes	
<b>Leg Upper Front Left</b>	181.7	No	-56.2
	79.5	Yes	
<b>Hip Right</b>	160.8	No	-71.6
	45.7	Yes	
<b>Hip Left</b>	94.1	No	6.4
	100.1	Yes	
<b>Knee Front Left</b>	1264.3	No	-23.6
	965.8	Yes	
<b>Elbow Left</b>	1379	No	-
	1379	Yes	
<b>Knee Front Right</b>	1379	No	-
	1379	Yes	
<b>Elbow Right</b>	1379	No	-21.1
	1087.5	Yes	
<b>Chest Left</b>	128.3	No	-20.0
	102.6	Yes	
<b>Chest Right</b>	127.7	No	-3.1
	123.7	Yes	
<b>Average %</b>			<b>-22</b>

Table 25 – Peak pressures recorded for the leopard crawl performed in the laboratory by Subject A.

The distributions of peak pressures obtained for the right knee during the leopard crawl on grassland are shown in Figure 60. Over 50% of the peak pressures were at or below 100 kPa when the exercise was performed without the additional webbing and back pack. By comparison, conducting the exercise with the added kit, approximately 23% of the peak pressures fell between 51 kPa and 100 kPa with around the same fraction falling between 101 kPa and 150 kPa. For both exercises, the maximum peak pressure of 1379 kPa was encountered for less than 0.5% of the total exercise.

Similar findings were observed for the left knee and right and left elbows (Appendix C).

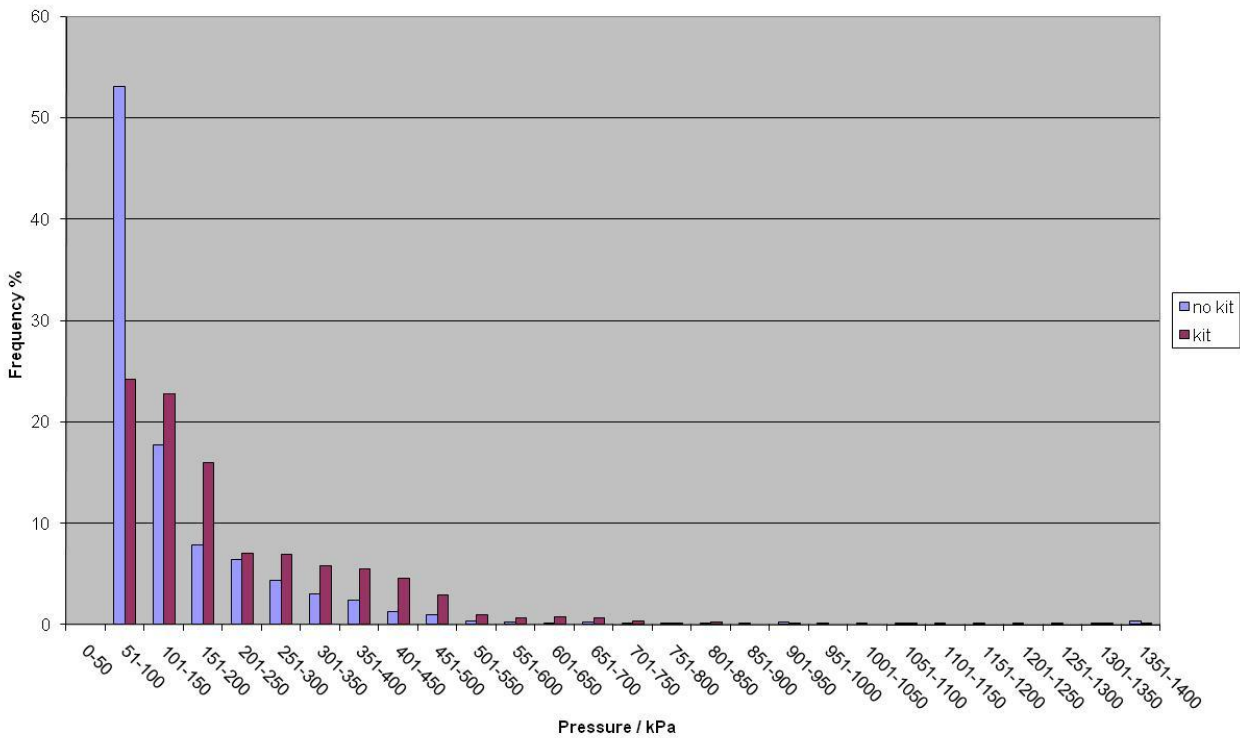

Figure 60 – Peak pressure distribution recorded for the right knee during the leopard crawl performed in the laboratory by Subject A.

### 5.3.3 Subject B (Grassland)

Owing to time constraints, Subject B performed the leopard crawl on grassland only.

#### 5.3.3.1 Mean Pressure

The mean pressures obtained for Subject B are displayed in Figure 61 and Table 26.

The mean pressures generated by Subject B were very similar to those generated by Subject A, and also fairly consistent with previous results from the other two exercises. Broadly speaking, the knees and elbow were in the region of 100 kPa (excluding the left elbow that measured 150 kPa), with the remaining locations falling between 40 kPa and 60 kPa.

Performing the leopard crawl when wearing additional kit resulted in a reduction in the mean pressure of 4% (Table 26).

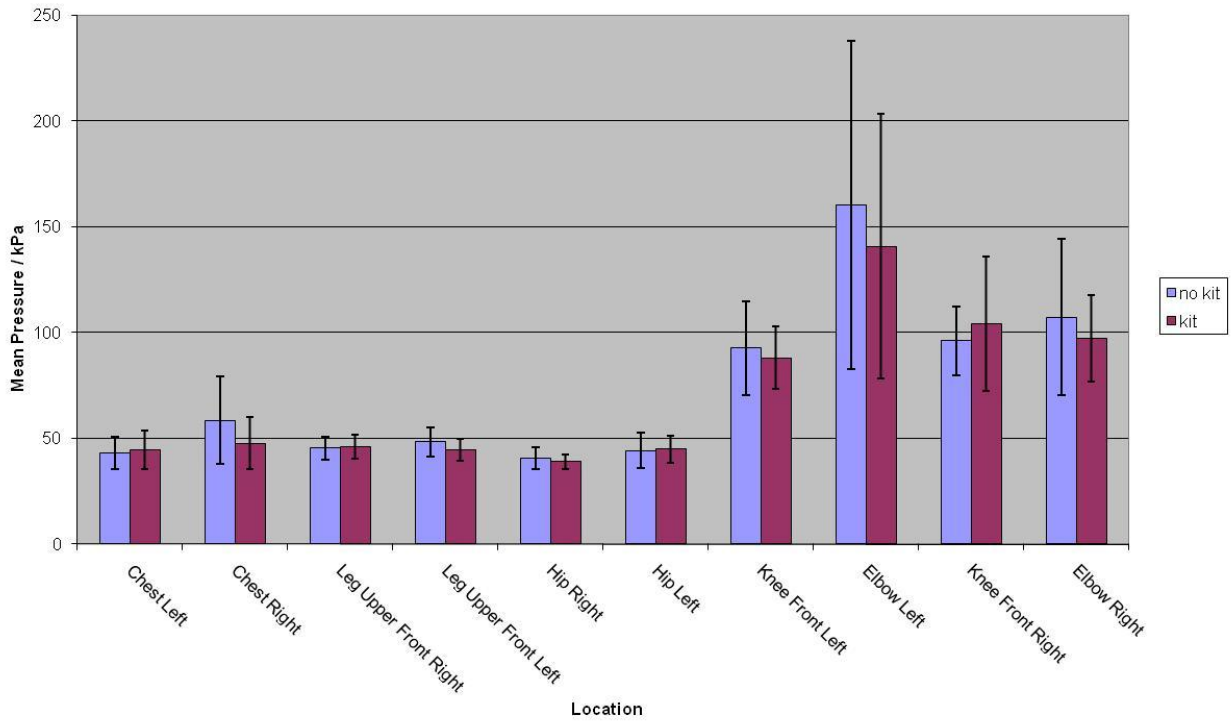

Figure 61 – Mean pressures obtained for the leopard crawl performed on grassland by Subject B.

**UNCLASSIFIED**

	<i>Mean Pressure / kPa</i>	<i>SD</i>	<i>Kit</i>	<i>Change due to kit / %</i>
<b>Leg Upper Front Right</b>	45.4	5.5	No	1.5
	46.1	5.8	Yes	
<b>Leg Upper Front Left</b>	48.4	6.9	No	-7.9
	44.6	5.2	Yes	
<b>Hip Right</b>	40.7	5	No	-3.9
	39.1	3.4	Yes	
<b>Hip Left</b>	44.3	8.6	No	1.1
	44.8	6.4	Yes	
<b>Knee Front Left</b>	92.6	22	No	-4.9
	88.1	14.9	Yes	
<b>Elbow Left</b>	160.3	77.5	No	-12.2
	140.8	62.5	Yes	
<b>Knee Front Right</b>	96.2	16.3	No	8.3
	104.2	31.7	Yes	
<b>Elbow Right</b>	107.4	37	No	-9.3
	97.4	20.3	Yes	
<b>Chest Left</b>	43.1	7.4	No	3.2
	44.5	9.2	Yes	
<b>Chest Right</b>	58.5	20.6	No	-18.5
	47.7	12.4	Yes	
<b>Average %</b>				<b>-4</b>

Table 26 – Mean pressures, and associated standard deviations (SD), obtained for the leopard crawl performed on grassland by Subject B.

**5.3.3.2 Peak Pressure**

The peak pressures obtained during the leopard crawl, performed on grassland by Subject B, are shown in Figure 62 and Table 27.

The left and right elbow generated peak pressures that reached the 1379 kPa upper calibration limit. However, unlike the results obtained for Subject A, the peak pressures generated at the left and right knees were below 1 MPa.

Similar to the findings for Subject A, the peak pressures generated at the chest, upper legs and hips all fell below 200 kPa.

The load of the additional kit had the biggest impact for the left side of the chest, increasing the recorded peak pressure by 50%. However, overall, the effect of the additional kit was considerably lower at 3%.

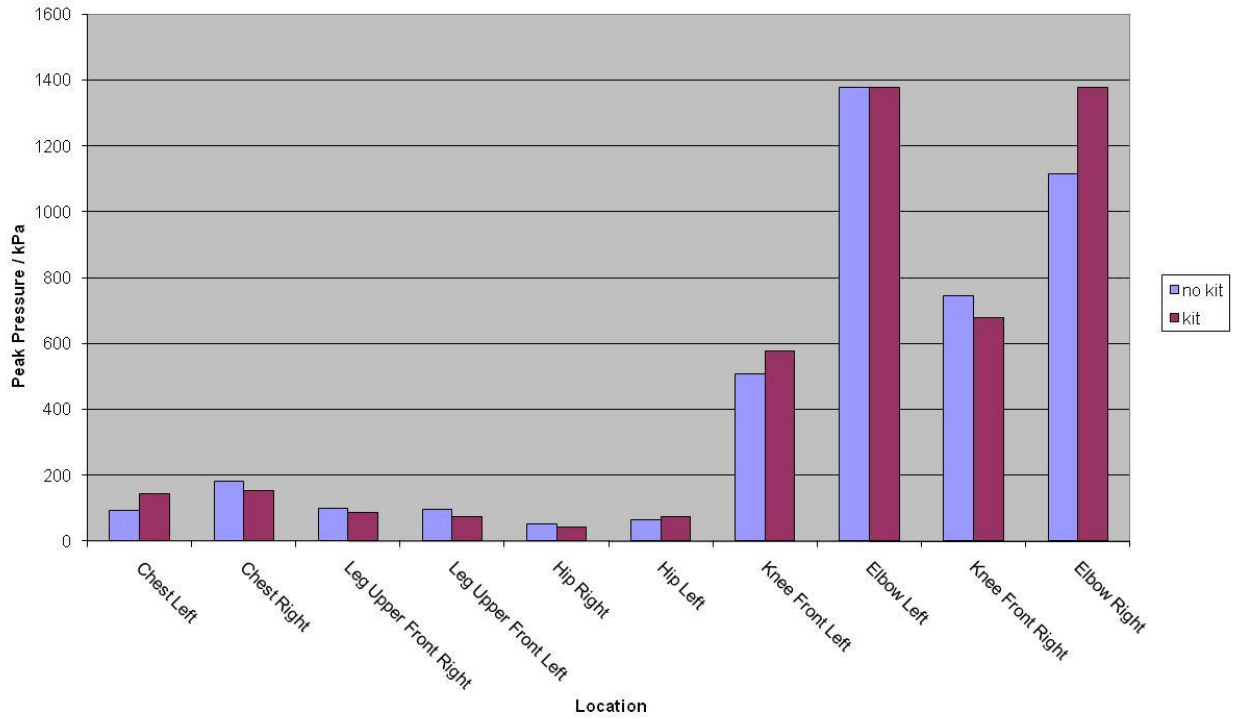

Figure 62 – Peak pressures obtained for the leopard crawl performed on grassland by Subject B.

**UNCLASSIFIED**

	<i>Peak Pressure / kPa</i>	<i>Kit</i>	<i>Change due to kit / %</i>
<b>Leg Upper Front Right</b>	99.1	No	-10.8
	88.4	Yes	
<b>Leg Upper Front Left</b>	97.2	No	-22.6
	75.2	Yes	
<b>Hip Right</b>	53.2	No	-19.5
	42.8	Yes	
<b>Hip Left</b>	66	No	14.1
	75.3	Yes	
<b>Knee Front Left</b>	507.7	No	13.8
	578	Yes	
<b>Elbow Left</b>	1379	No	-
	1379	Yes	
<b>Knee Front Right</b>	745	No	-8.7
	679.9	Yes	
<b>Elbow Right</b>	1114.3	No	23.8
	1379	Yes	
<b>Chest Left</b>	94.8	No	50.3
	142.5	Yes	
<b>Chest Right</b>	181.6	No	-14.8
	154.7	Yes	
<b>Average %</b>			<b>3</b>

Table 27 – Peak pressures recorded for the leopard crawl performed on grassland by Subject B.

The distributions for the peak pressures recorded at the right elbow are shown in Figure 63. The majority of peak pressures were at or below 200 kPa, followed by a sharp decrease in the frequency with increasing pressure ranges. The maximum peak pressure of 1379 kPa was encountered less than 0.5% over the duration of the exercise.

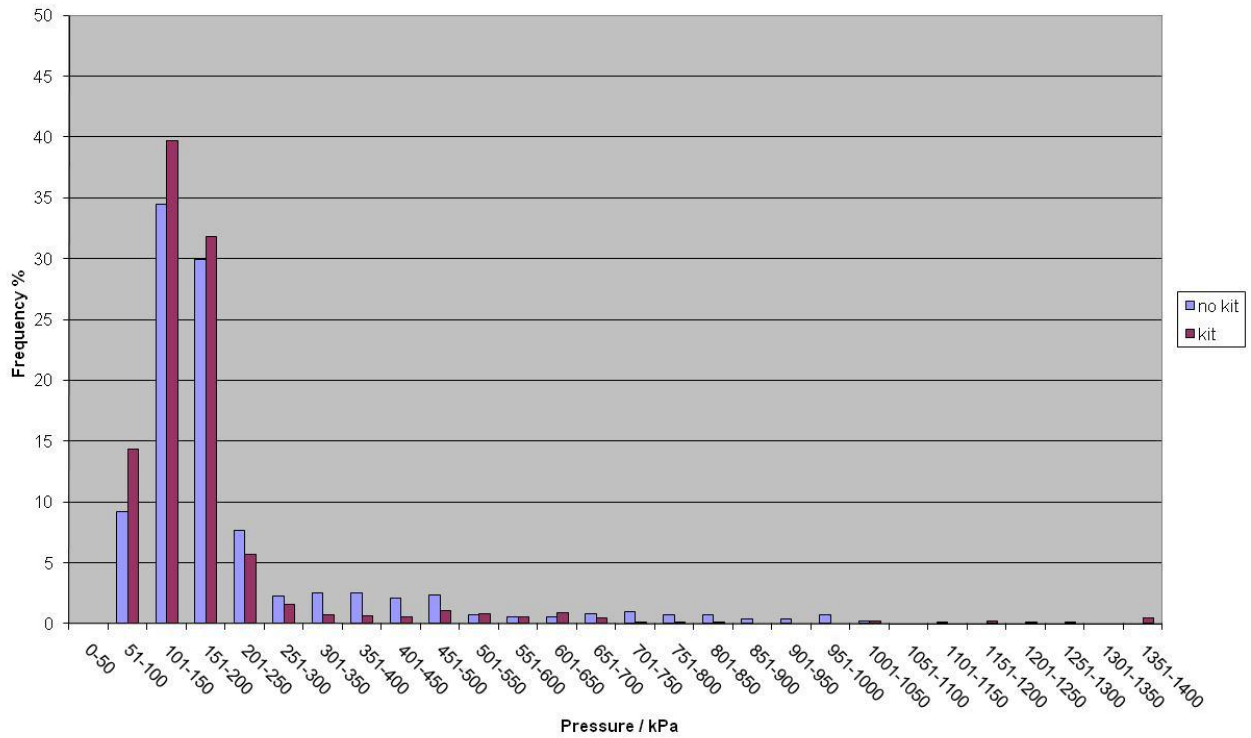

Figure 63 – Peak pressure distribution recorded for the right elbow during the leopard crawl performed on grassland by Subject B.

### 5.3.4 Subject C (Laboratory)

Owing to poor conditions, Subject C performed the leopard crawl in the laboratory only.

#### 5.3.4.1 Mean Pressure

The mean pressures obtained for the leopard crawl exercise, performed in the laboratory by Subject C, are displayed in Figure 64 and Table 28.

The mean pressures generated by Subject C were very similar to those generated by Subjects A and B, and also fairly consistent with previous results from the other two exercises. The biggest difference was observed for the elbows where the mean pressures were between 145 kPa and 161 kPa.

Performing the exercise in additional kit had the biggest impact on the ‘leg lower front right’ where an increase in the mean pressure of 11 % was observed. However, the overall effect of additional kit was very low, resulting in an increase in mean pressure by only 1%.

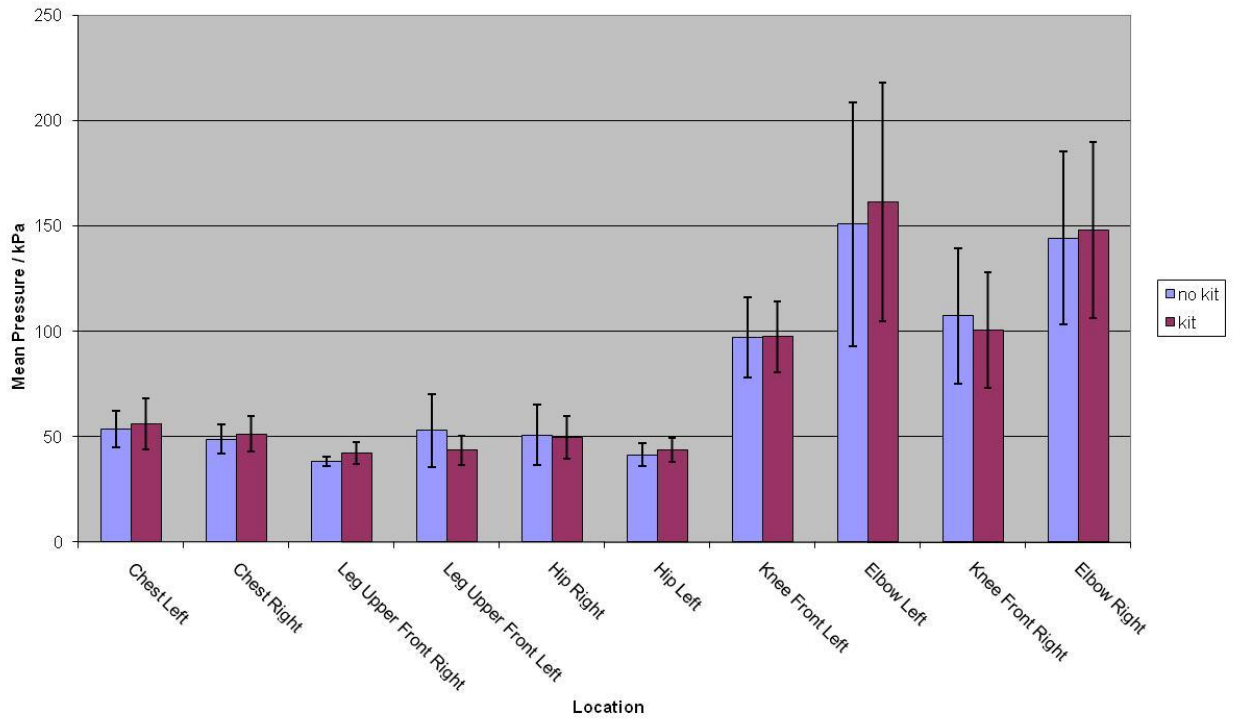

Figure 64 – Mean pressures obtained for the leopard crawl performed in the laboratory by Subject C.

	<i>Mean Pressure / kPa</i>	<i>SD</i>	<i>Kit</i>	<i>Change due to kit /%</i>
<b>Leg Upper Front Right</b>	38.2	2.2	No	10.7
	42.3	5	Yes	
<b>Leg Upper Front Left</b>	52.9	17.3	No	-17.6
	43.6	6.8	Yes	
<b>Hip Right</b>	50.8	14.2	No	-2.8
	49.4	10.1	Yes	
<b>Hip Left</b>	41.5	5.2	No	5.1
	43.6	5.7	Yes	
<b>Knee Front Left</b>	97	19.1	No	0.5
	97.5	16.8	Yes	
<b>Elbow Left</b>	150.8	57.9	No	7.0
	161.3	56.5	Yes	
<b>Knee Front Right</b>	107.3	32.1	No	-6.3
	100.5	27.5	Yes	
<b>Elbow Right</b>	144.3	40.9	No	2.5
	147.9	41.9	Yes	
<b>Chest Left</b>	53.7	8.5	No	4.7
	56.2	12	Yes	
<b>Chest Right</b>	48.8	7	No	5.3
	51.4	8.4	Yes	
<b>Average %</b>				<b>1</b>

Table 28 – Mean pressures, and associated standard deviations (SD), obtained for the leopard crawl performed in the laboratory by Subject C.

#### 5.3.4.2 Peak Pressure

The peak pressures obtained during the leopard crawl, performed in the laboratory by Subject C, are shown in Figure 59 and Table 29.

The left and right elbow and right knee generated peak pressures that achieved the 1379 kPa upper calibration limit. However, similar to the results obtained for Subject B, the peak pressure generated at the left knee was less than 1 MPa.

Peak pressures generated at the chest, upper legs and hips all fell below 200 kPa, as found for Subjects A and B, regardless if the exercise was performed on grassland or in the laboratory.

A large change in the peak pressure of 65% was observed for the ‘leg upper front right’ when additional kit was worn. However, quite the opposite was seen for the ‘leg upper front left’ where there was a reduction of 61%. Overall, there was a reduction of 7% in the peak pressures recorded when performing the exercise with the additional kit.

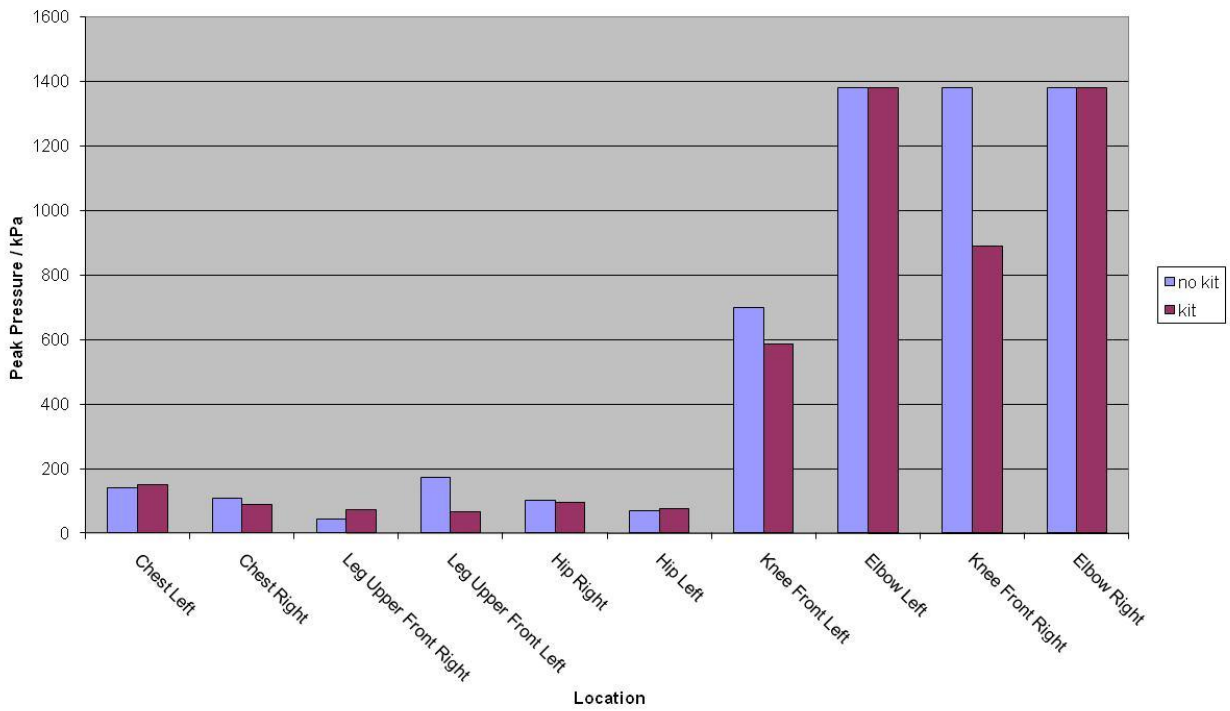

Figure 65 – Peak pressures obtained for the leopard crawl performed in the laboratory by Subject C.

**UNCLASSIFIED**

	<i>Peak Pressure / kPa</i>	<i>Kit</i>	<i>Change due to kit / %</i>
<b>Leg Upper Front Right</b>	44.3	No	65.0
	73.1	Yes	
<b>Leg Upper Front Left</b>	171.7	No	-60.9
	67.1	Yes	
<b>Hip Right</b>	100.6	No	-6.1
	94.5	Yes	
<b>Hip Left</b>	70	No	10.1
	77.1	Yes	
<b>Knee Front Left</b>	698.3	No	-16.1
	586	Yes	
<b>Elbow Left</b>	1379	No	-
	1379	Yes	
<b>Knee Front Right</b>	1379	No	-35.6
	888.4	Yes	
<b>Elbow Right</b>	1379	No	-
	1379	Yes	
<b>Chest Left</b>	138.9	No	7.1
	148.7	Yes	
<b>Chest Right</b>	108.8	No	-18.8
	88.4	Yes	
<b>Average %</b>			<b>-7</b>

Table 29 – Peak pressures recorded for the leopard crawl performed in the laboratory by Subject C.

The distributions of the peak pressures recorded for the right elbow are shown in Figure 66. The majority of peak pressures were at or below 300 kPa for both with and without kit. However, the most pronounced deviation in the general trend was the high frequency at which the maximum pressure was recorded. The maximum pressure range was encountered 17% of the time when performing the exercise without the additional webbing and back pack, and 11% of the time when wearing it.

A similar distribution profile was observed for the left elbow/forearm (Appendix C), however, in this instance the majority of the peak pressures fell within the highest pressure interval.

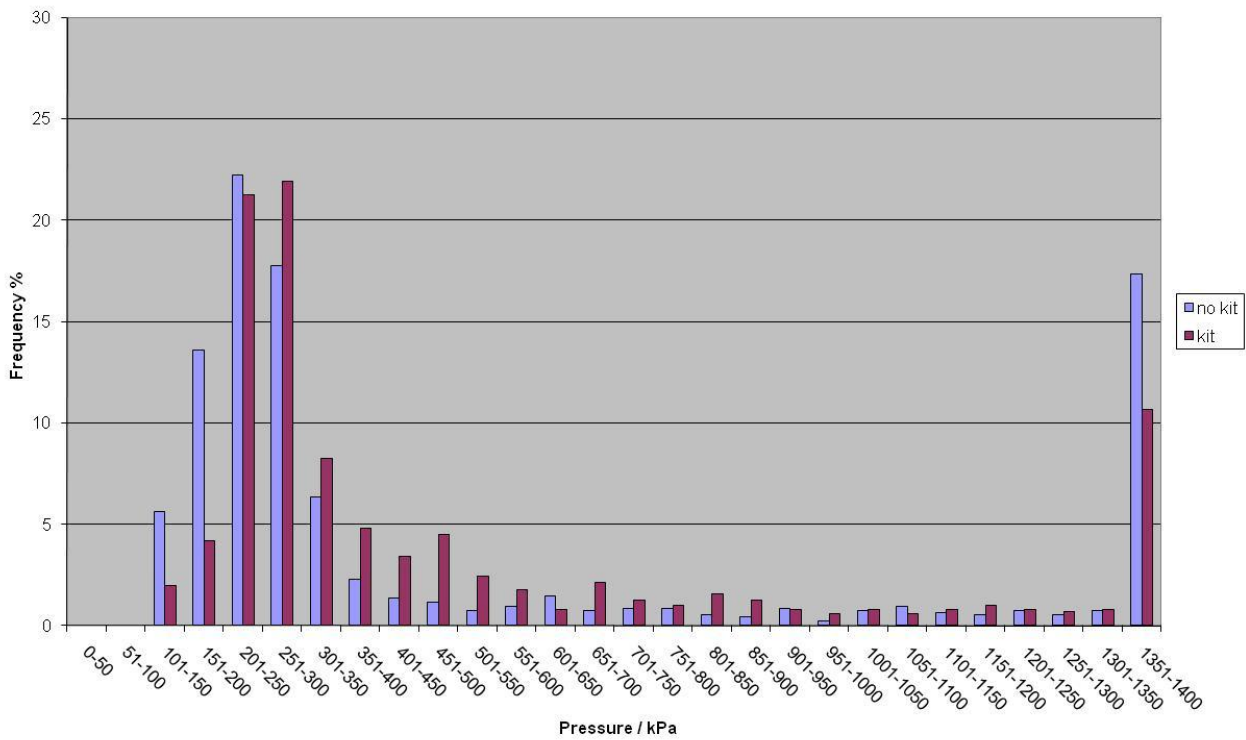

Figure 66 – Peak pressure distribution recorded for the right elbow during the leopard crawl performed on grassland by Subject C.

## 6 Discussion

The overall aim of the programme was to develop a prototype pressure sensitive suit to accurately map pressure and contact profiles experienced by CBRN protective clothing on the battlefield. This has been achieved to allow real-time pressure data to be captured whilst performing activities in the field that cannot be readily simulated in the laboratory. To assess the functionality of the system, the suit was used to capture pressure data from a series of exercises designed to mimic battlefield-type activities.

Since the field trials involved only three military subjects, the data should be treated as indicative only. Based upon advice from Dstl statisticians, approximately forty volunteers would be required to obtain statistically valid data.

Furthermore, it is difficult to compare the results from the different exercises as the order in which they were performed (as a result of necessity) would have had an effect on the recorded pressures. For instance, when observing the trials it was very clear that the exercises caused the subjects to become fatigued, which increased as the trial went on. All the exercises performed with additional kit took place after the exercise had been performed without kit, and all the exercises performed in the laboratory took place after the exercises on grassland; apart from those for Subject C, where all the exercises were conducted in the laboratory owing to poor weather conditions.

Broadly speaking, the results obtained from the three trials (kneeling, assault and leopard crawl) indicate that the mean pressures captured for each location was similar for the three subjects despite the fact the subjects differed in weight and height, and were from different military backgrounds. The reason for this could be explained by the tempo at which the exercises were performed and also the technique used to execute each exercise. Based upon observations made during the trial, Subject A was more dynamic than Subject B, who was more dynamic than Subject C. This could account for the similar mean pressures despite the fact that Subject C was the heaviest. When referring to the dynamics of human motion, there is also a subtle difference between a subject's 'actual' mass and 'apparent' mass. The contact force and energy exerted when a moving body makes contact with the ground will depend upon the body's 'apparent mass', which relies on the action of internal muscles, joint rigidity and body posture that can change during falling [7]. These factors will depend upon the exercise technique used by each subject and is impossible to determine unless additional biomechanical information is available.

To add functionality to the pressure sensing suit capability, and gain additional information that may be used to interpret results, accelerometers could be integrated into the system to provide information on the subject's dynamics.

Terrain appeared to have little influence on the pressures obtained during the three trials. However, the laboratory trials were performed on ¼-inch carpet underlay that offered a degree of compliance, as opposed to a hard surface. It is expected that there may have been little difference between this surface and the grassland. To extend this study and increase the knowledge of the type of pressures experienced in the field, similar trials should be performed on other terrains, for example concrete and sand.

## UNCLASSIFIED

The additional kit did have an impact on the recorded pressures obtained during the trials. Table 30 summarises the average change in the mean and peak pressures obtained when wearing additional kit for all three subjects over the three exercises. The largest changes were observed for the peak pressures recorded during the kneeling and assault exercises. By comparison, an overall reduction of 4% was observed for the peak pressures recorded during the leopard crawl. Small increases were observed in the mean pressures for the kneeling and assault exercises and overall no effect of additional kit was observed for the leopard crawl.

<i>Exercise</i>	<i>Ave Mean Pressure change %</i>	<i>Ave Peak Pressure change %</i>
Kneeling	+3	+13
Assault	+2	+18
Leopard Crawl	0	-4

Table 30 – Summary of the average pressure changes resulting from the additional kit load

Extremely high peak pressures were recorded during the exercises, namely for the knees and elbows. However, when viewing the distribution of peak pressures over the duration of the exercises, the fraction of time that these extremely high pressures were encountered was in fact very low in the majority of cases. The exception to this was for Subject C during the leopard crawl exercise where up to 33% of the peak pressures encountered for the left elbow fell into the highest pressure range (Annex C). To mitigate against the extremely high peak pressures observed at the knees and elbow/forearms, chemical resistant knee and elbow pads may provide a feasible solution.

An important point to consider when analysing the trials data presented in this report is that the sensors only measure the vertical forces experienced by the subject and not the shear forces. Independent laboratory tests conducted at Dstl Porton Down have demonstrated that the penetration of liquids through fabrics is broadly governed by the vertical force component [6]. The presence of shear may be beneficial in the sense that it could cause a liquid droplet to spread over a large surface area and therefore help reduce the amount of penetration through the fabric. Simply increasing the vertical pressure used in swatch and full system tests may therefore result in a worse situation than that actually experienced in the field.

To understand the impact that these pressures (and the presence of shear) will have on agent penetration through a CBRN garment, it would be very useful to perform a series of MIST (man-in-simulant) tests using liquid simulant. Depositing droplets of simulants on to the target areas and performing the exercises used in this trial will allow the amount of penetration through a CBRN garment to be determined and provide a clearer understanding of the barrier properties of current protective apparel.

Sensor performance was assessed after the field trials using a 5565 Instron in order to examine pressure response. This assessment revealed that the sensors located the knees

and elbows had suffered some damaged during the trials, which would have been caused by shear forces. The damage resulted in rows and columns of sensels being no longer active; this was most noticeable for the sensor located at the right elbow that resulted in approximately 30% of the sensels no longer exhibiting a pressure response. The damage, however, did not render the sensors completely ineffective, as pressure readings were still obtained for the active sensels.

If this capability is to be developed further, it is therefore recommended that the sensors are made more robust. Alternatively, since it has been shown that the pressures experienced at elbows and knees can be very high, the use of protective pads may be the only practical option for providing high levels of liquid protection at these locations. If this is the case, then sensors would no longer be required at the knees and elbows, but instead could be located at other additional positions. This would also have the advantage of preventing the pads having to be exchanged between different activities. As stated earlier, it would also be recommended that the dynamic range of the sensors be increased.

## 7 Conclusions

- A pressure sensing suit capability has been developed to accurately map pressure and contact profiles experienced by CBRN protective clothing on the battlefield. The suit has been employed to capture real-time pressure data from a series of battlefield exercises that were designed in consultation with UK and US military officers.
- Pressure data obtained from the field trials should be used for indication only. Pressures that fell outside the calibration range of the sensors were not recorded.
- Typically, mean pressures at the elbows and knees ranged between 90 kPa to 160 kPa and the remaining locations across the body fell between 40 kPa and 60 kPa.
- Peak pressures at the elbows and knees were recorded up to 1379 kPa; however, generally these extremely high pressures were encountered for less than 2% over the duration of the exercise.
- Performing the exercises whilst wearing the additional combat webbing and a back pack (weighing ~ 15 kg) had the biggest impact on the peak pressures recorded for the kneeling and assault exercises where average increases of 13% and 18% were observed respectively.
- Sensors located at the knees and elbows suffered some damage during the trials. This was attributed to the high shear forces experienced. The damage, however, did not render the sensors completely ineffective, as pressure readings were still obtained for the active sensors.
- A more complete understanding of the effects of pressure impaction on liquid penetration through clothing is required before changes in current swatch and full system clothing tests can be recommended.

## 8 Future Programme Directions

- Further carefully planned trials with a larger number of volunteers should be conducted in order to provide more statistically robust data.
- If this capability is to be developed further, it is recommended that the sensors are made more robust. Alternatively, since it has been shown that the pressures experienced at elbows and knees can be very high, the use of protective pads may be the only practical option for providing high levels of liquid protection at these locations. If this is the case, then sensors would no longer be required at the knees and elbows, but instead could be located at other additional positions. This would also have the advantage of preventing the pads having to be exchanged between different activities. It is also recommended that the dynamic range of the sensors be increased.
- Man-in-simulant tests should be conducted to investigate the real impact on protection.
- The extent of activities performed in the pressure suit should be extended to cover other specialist roles within the military.
- Pressure data should be obtained for other types of terrain, for example desert, road, etc.
- Additional functionality could be added to the system by including accelerometers to provide information on the dynamics of a subject's motion.
- The use of protective pads at critical pressure points should be considered in future CBRN apparel design.

**9 List of references**

1. SUMMERS, M.J., IPE Field Operations Effects Standard – QTC Pressure Sensor Development, Dstl/TR29247, April 2008
2. SUMMERS, M.J., IPE Operations Field Effect Standard – QTC Pressure Sensor Evaluation, Dstl/TR32052, December 2008
3. SUMMERS, M.J., IPE Operations Field Effect Standard – Evaluation of Commercial-off-the-Shelf (COTS) Pressure Sensing Technologies, Dstl/TR36619, July 2009.
4. SUMMERS, M.J., IPE Field Operations Effects Standard – Contact Pressures Experienced during Military Exercises, Dstl/TR40510, January 2010.
5. SUMMERS, M.J., IPE Field Operations Effects Standard – Review of Mobile Data Logging Devices, Dstl/TR40511, January 2010.
6. SUMMERS, M.J., Influence of Force Contact Angle (Shear) on Liquid Ingress through a Multi-layered Fabric, Dstl/TR40038, December 2009.
7. ZATSIORSKY, V. M., Kinetics of Human Motion, 1998.

10 Appendix A: Sensor specifications

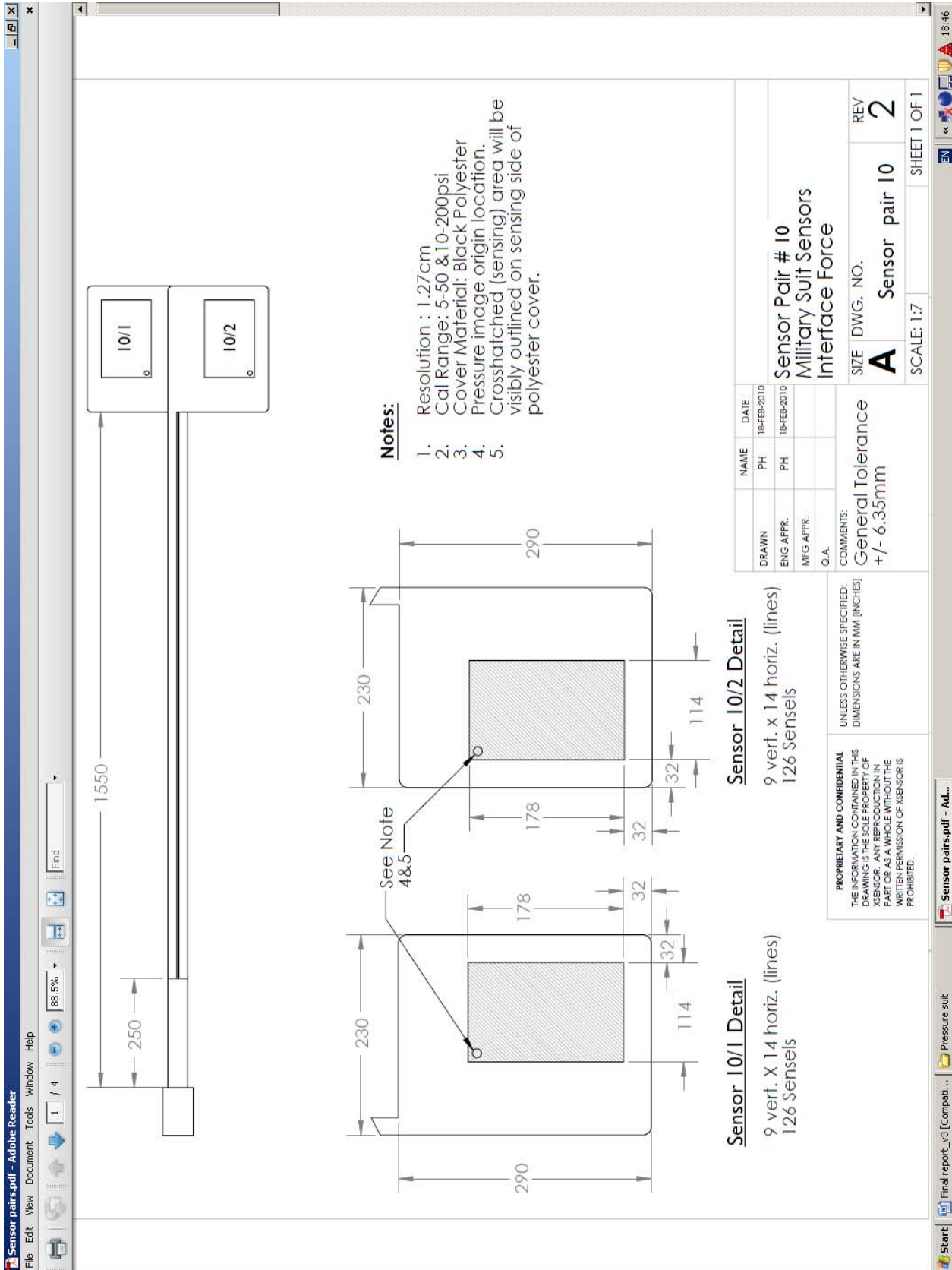

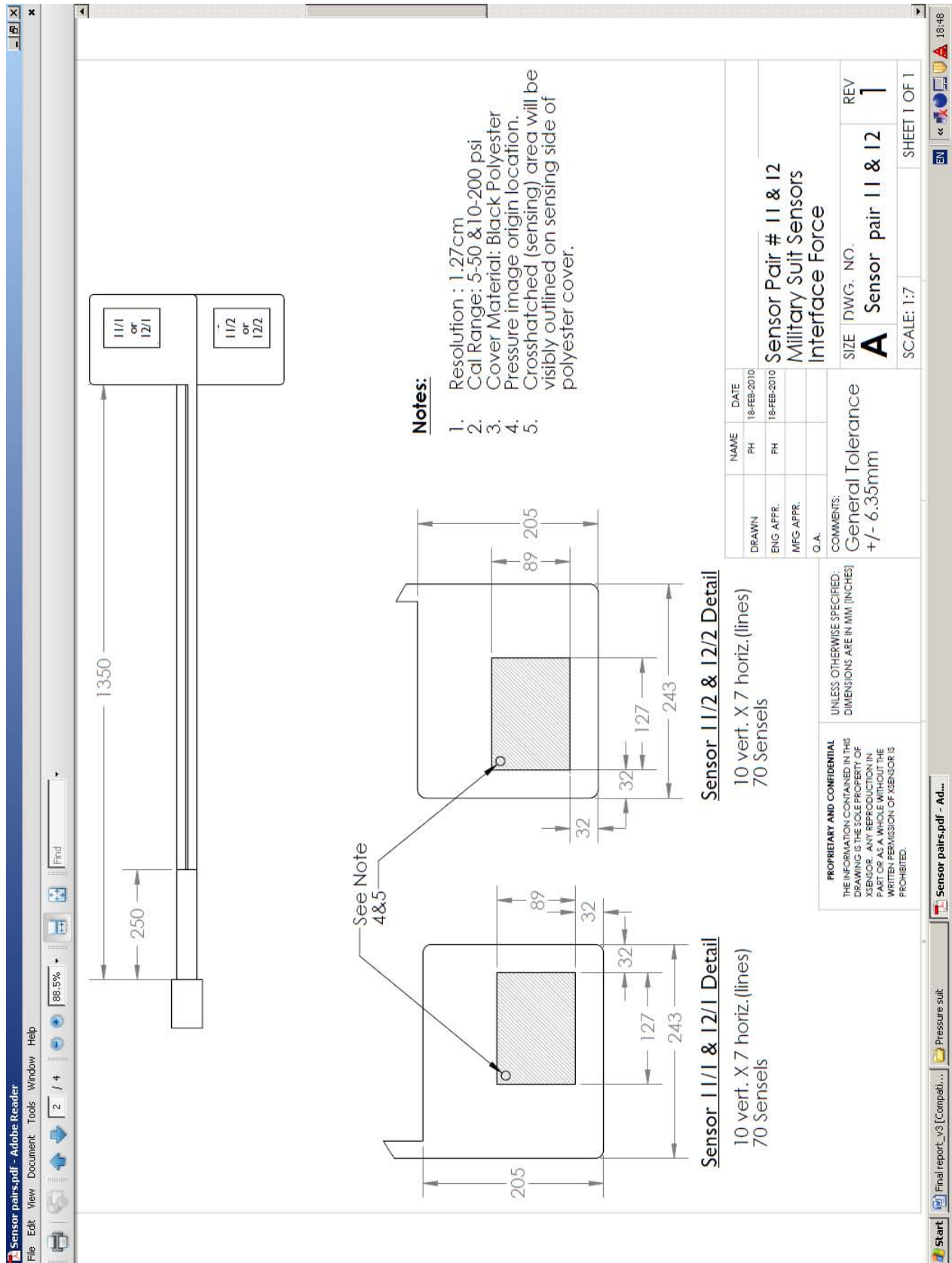

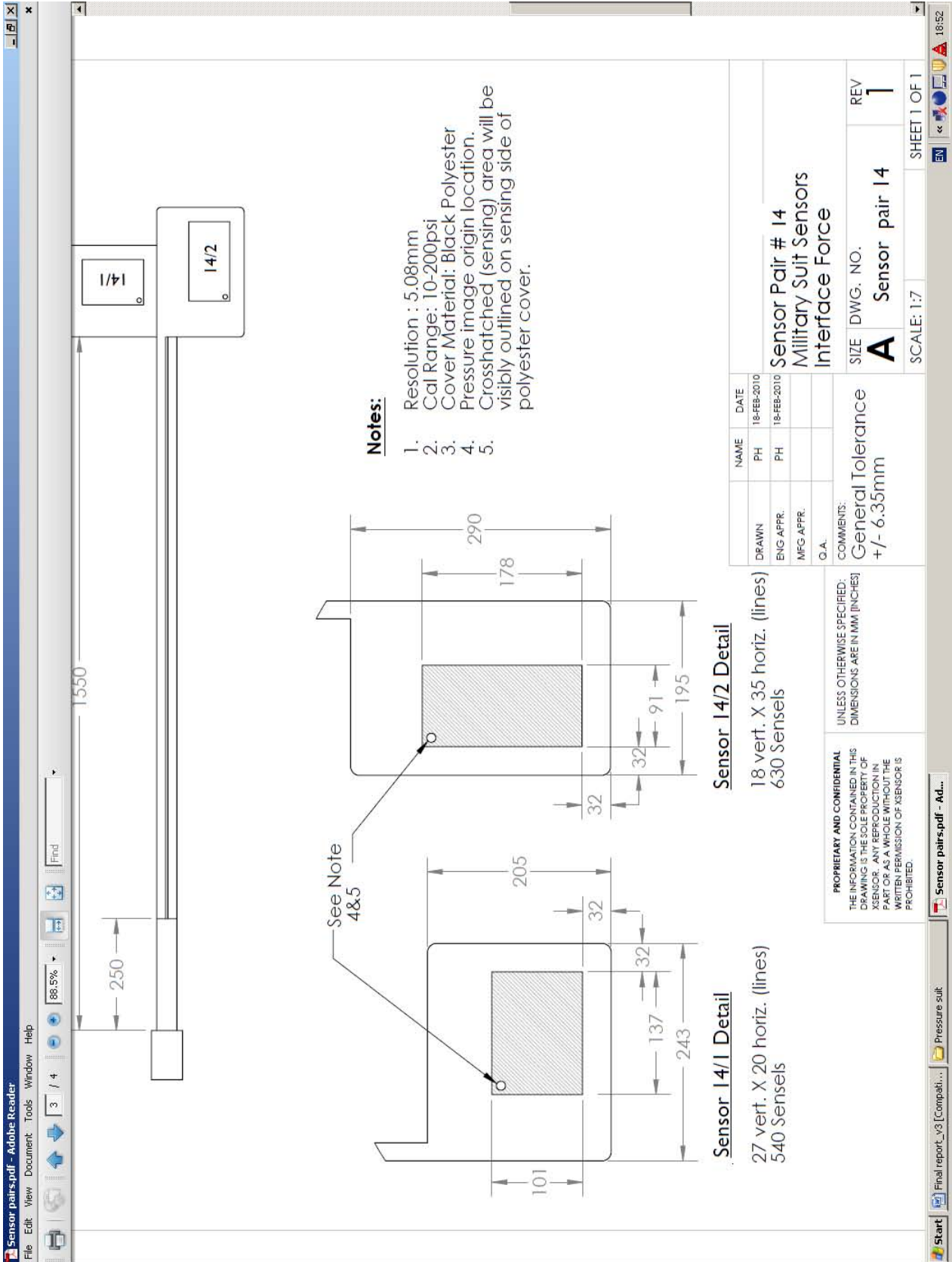

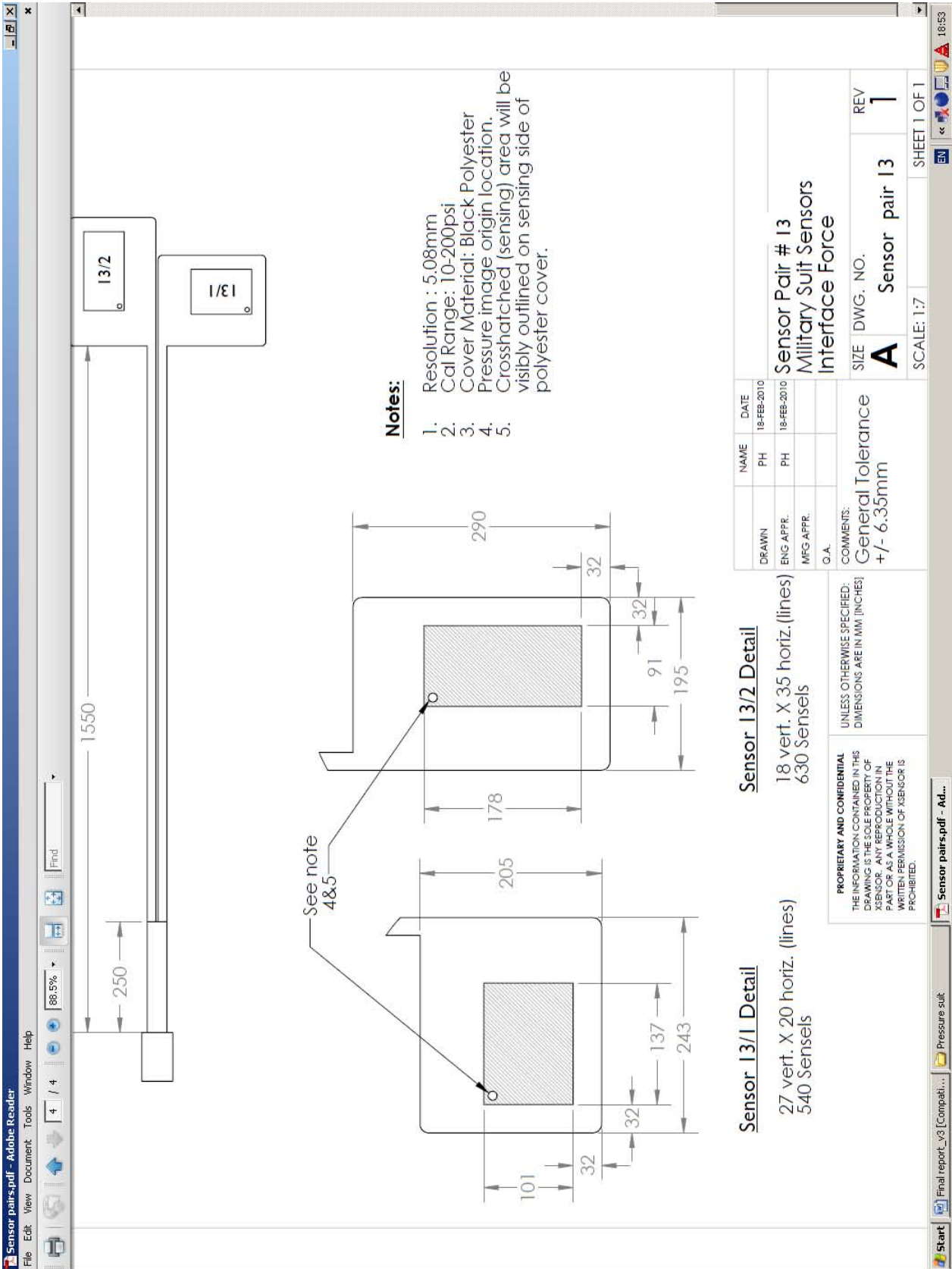

## 11 Appendix B: Suit design drawings

### 11.1 XSENSOR pad configurations

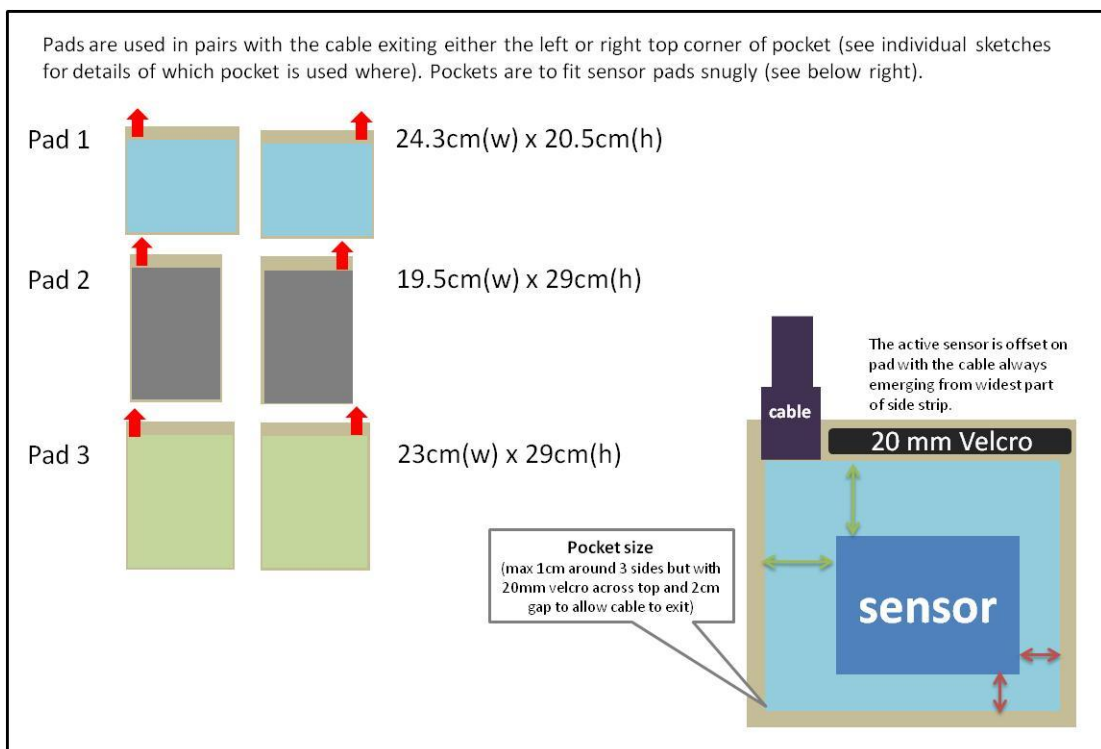
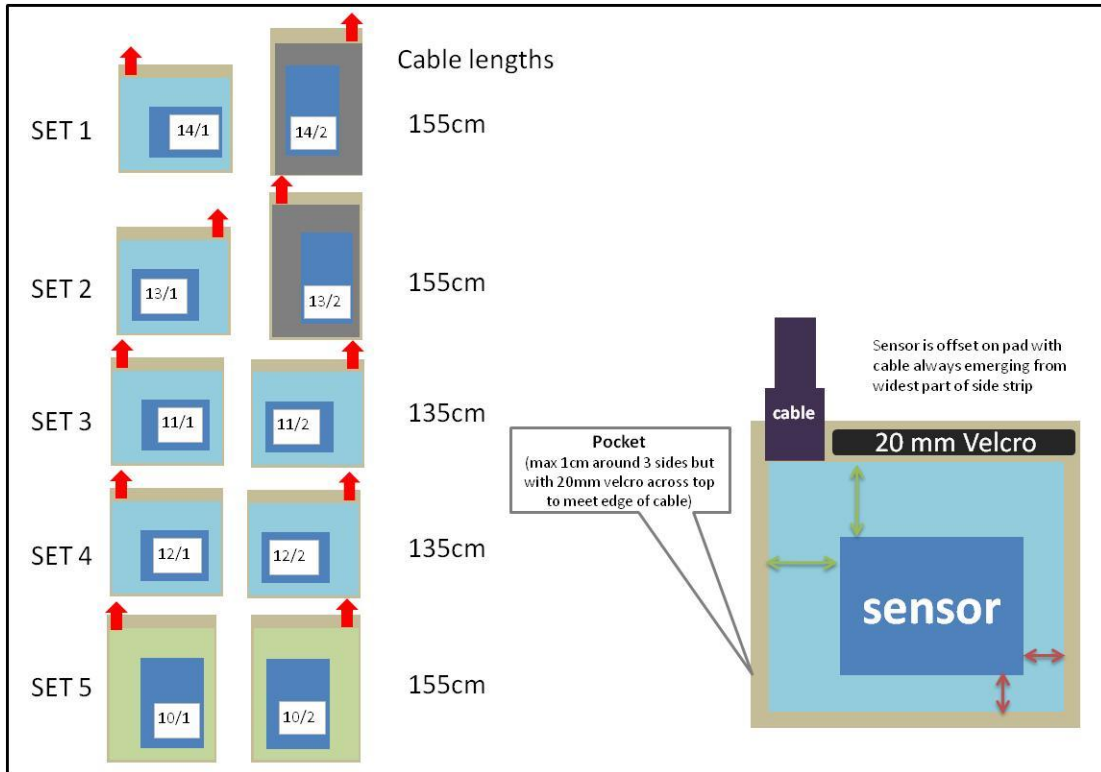

### 170 cm – INSIDE GARMENT LINING

• FRONT VIEW

Tie Tapes to be fixed *inside* each side of waist to “gather” cables together at top of trousers

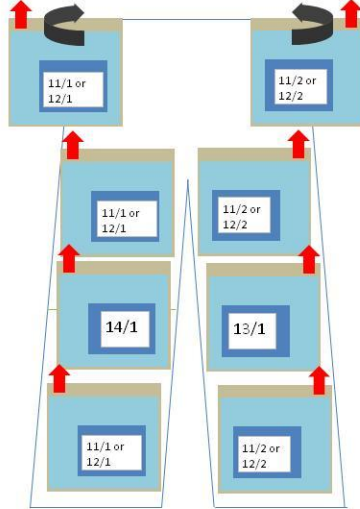

• BACK VIEW

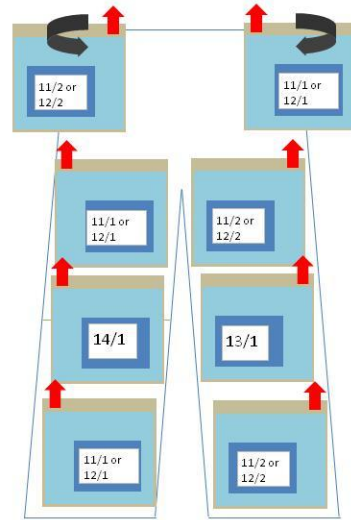

NB: just one hip pocket is applied at each side - centred across the side seam with the cable exiting at the top corner on the back of the garment.  
Pockets on legs are duplicated front and back with the cables ALL exiting to the outside leg.

**NB: All pocket positions for individual sizes on final (duplicate) samples must be EXACTLY the same position as original samples**

### 180 & 190 cm – INSIDE GARMENT LINING

• FRONT VIEW

Tie Tapes to be fixed *inside* each side of waist to “gather” cables together at top of trousers

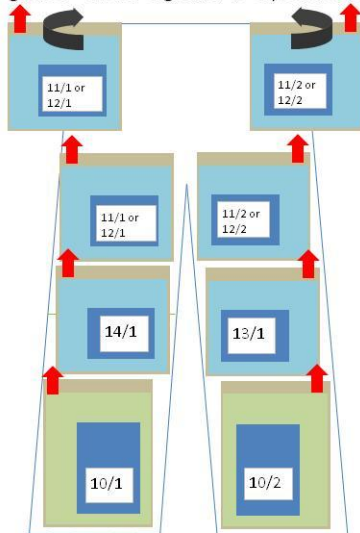

• BACK VIEW

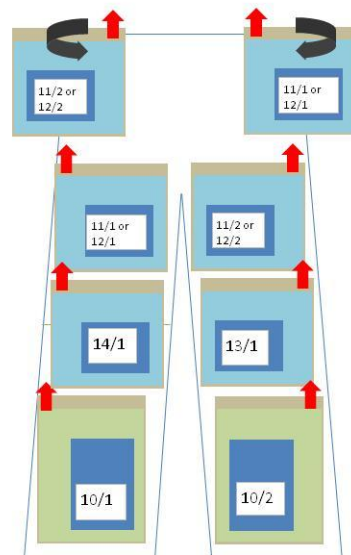

NB: just one hip pocket is applied at each side - centred across the side seam with the cable exiting at the top corner on the back of the garment.  
Pockets on legs are duplicated front and back with the cables ALL exiting to the outside leg.

**NB: All pocket positions for individual sizes on final (duplicate) samples must be EXACTLY the same position as original samples**

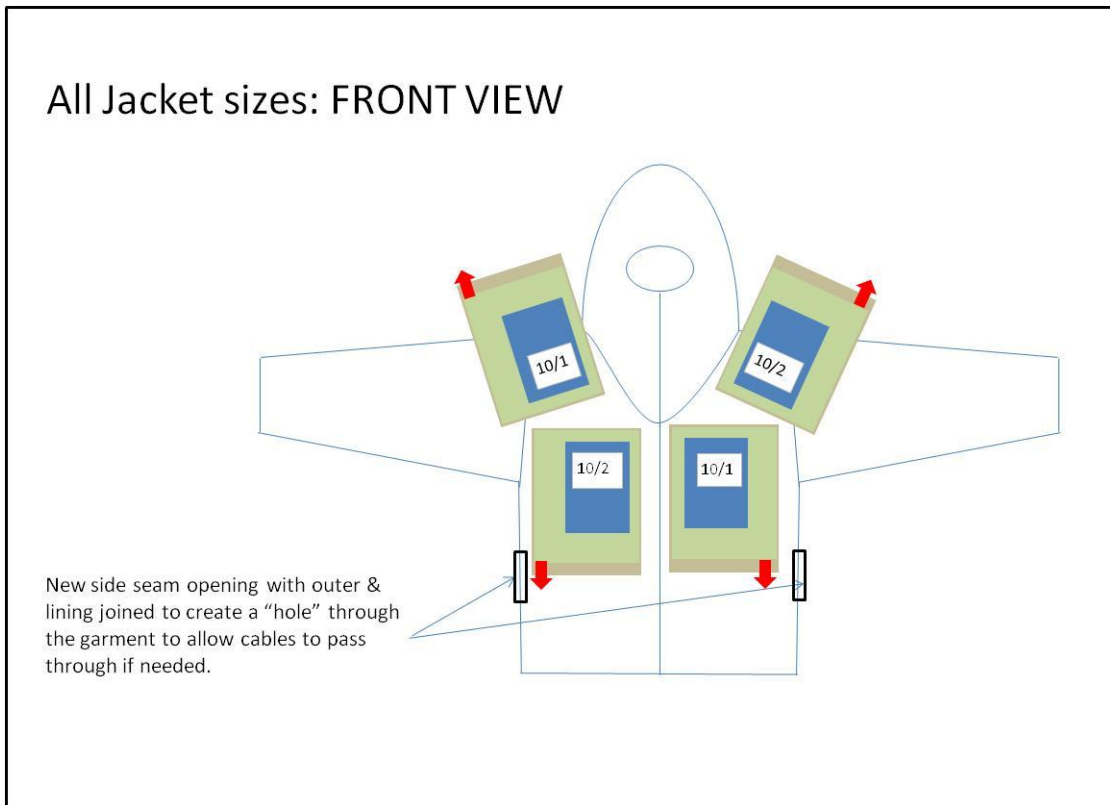
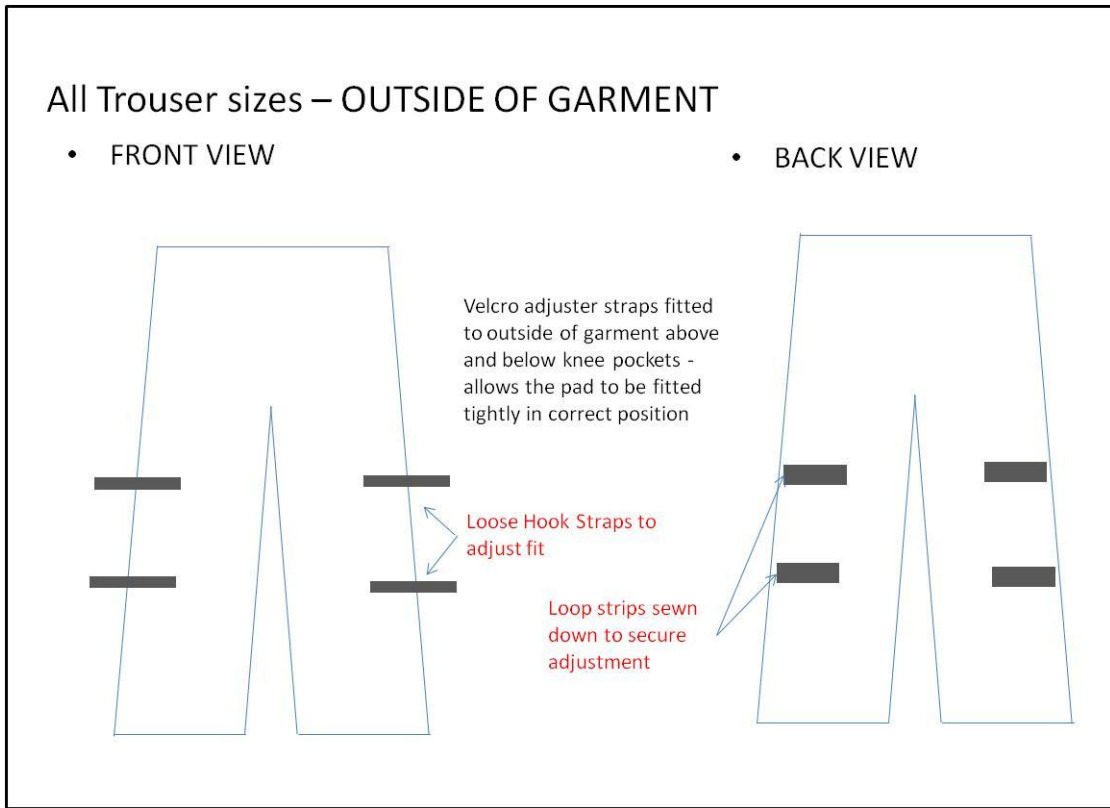

All Jacket sizes: BACK VIEW

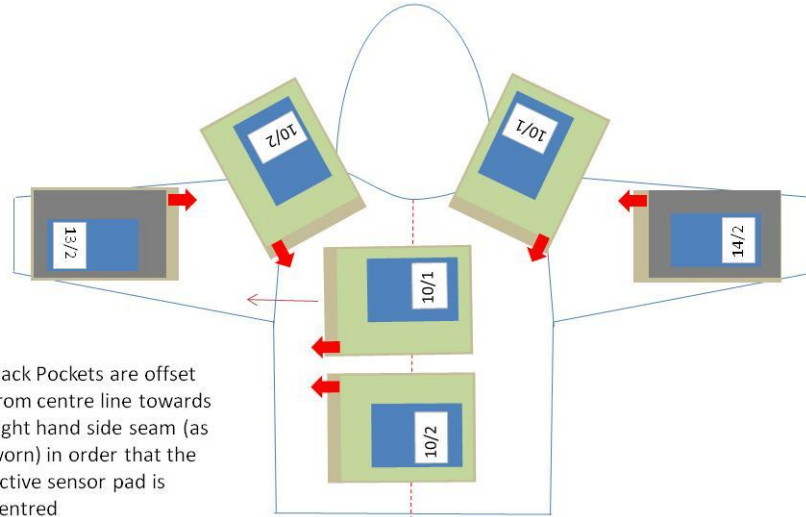

## 12 Appendix C: Peak pressure distributions

### 12.1 Assault

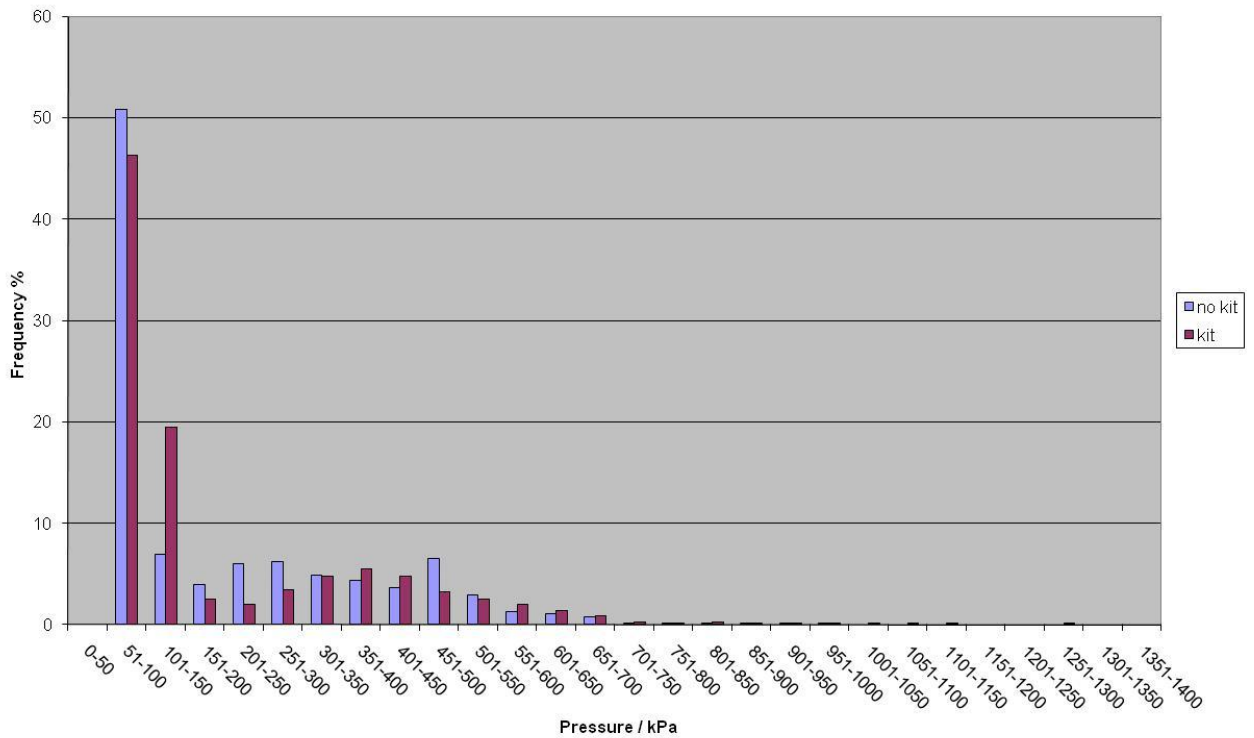

Figure 67 – Peak pressure distribution recorded for the left elbow during the assault exercise performed on grassland by Subject A.

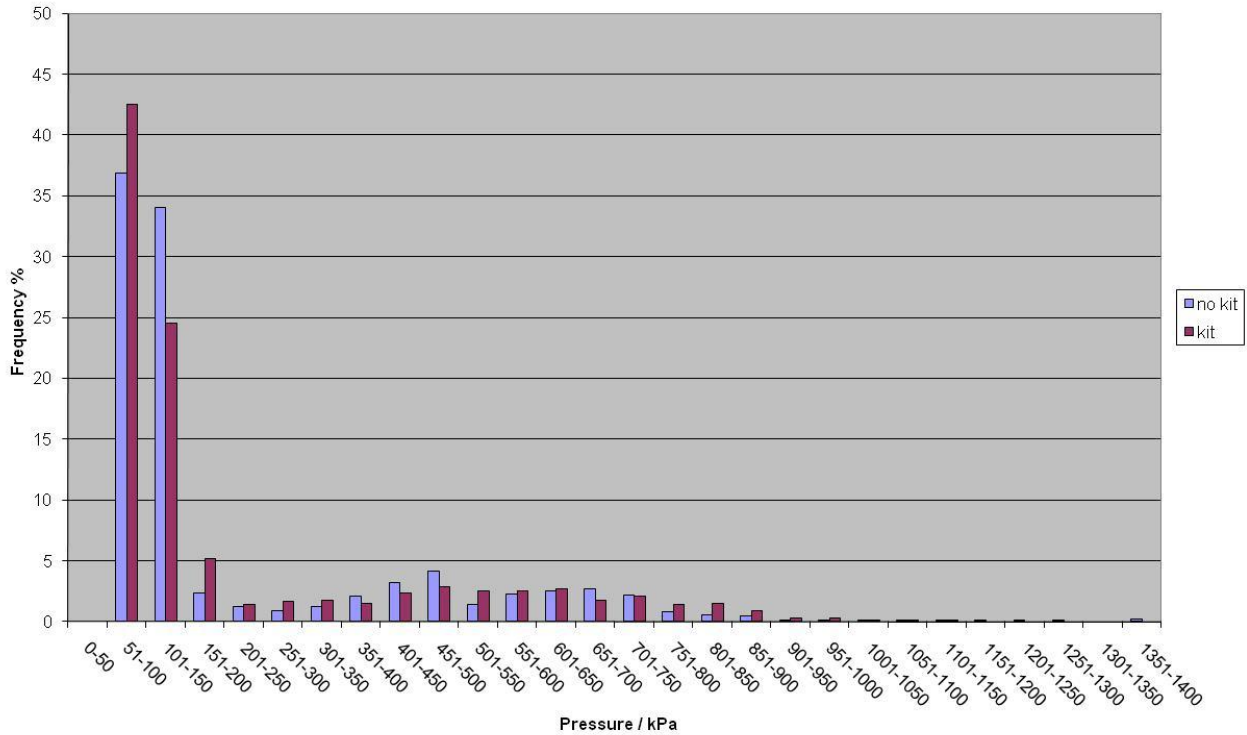

Figure 68 – Peak pressure distribution recorded for the left elbow during the assault exercise performed in the laboratory by Subject A.

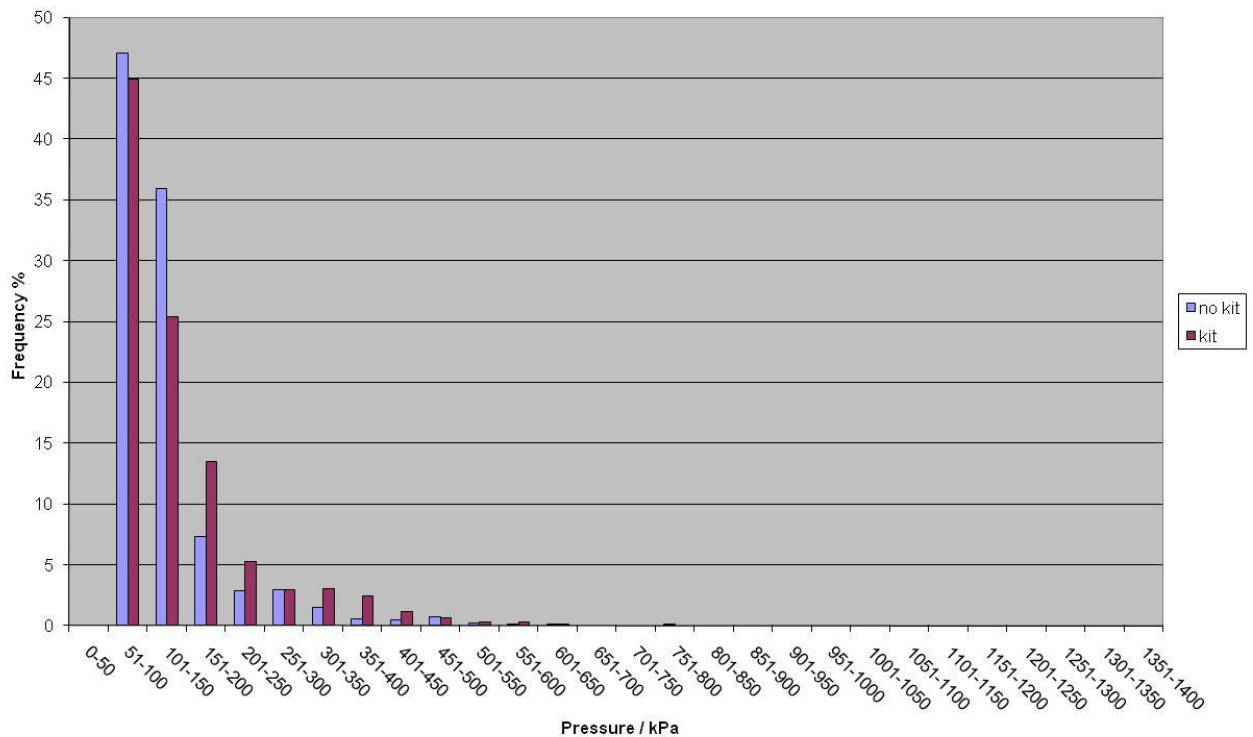

Figure 69 – Peak pressure distribution recorded for the left knee during the assault exercise performed on grassland by Subject A.

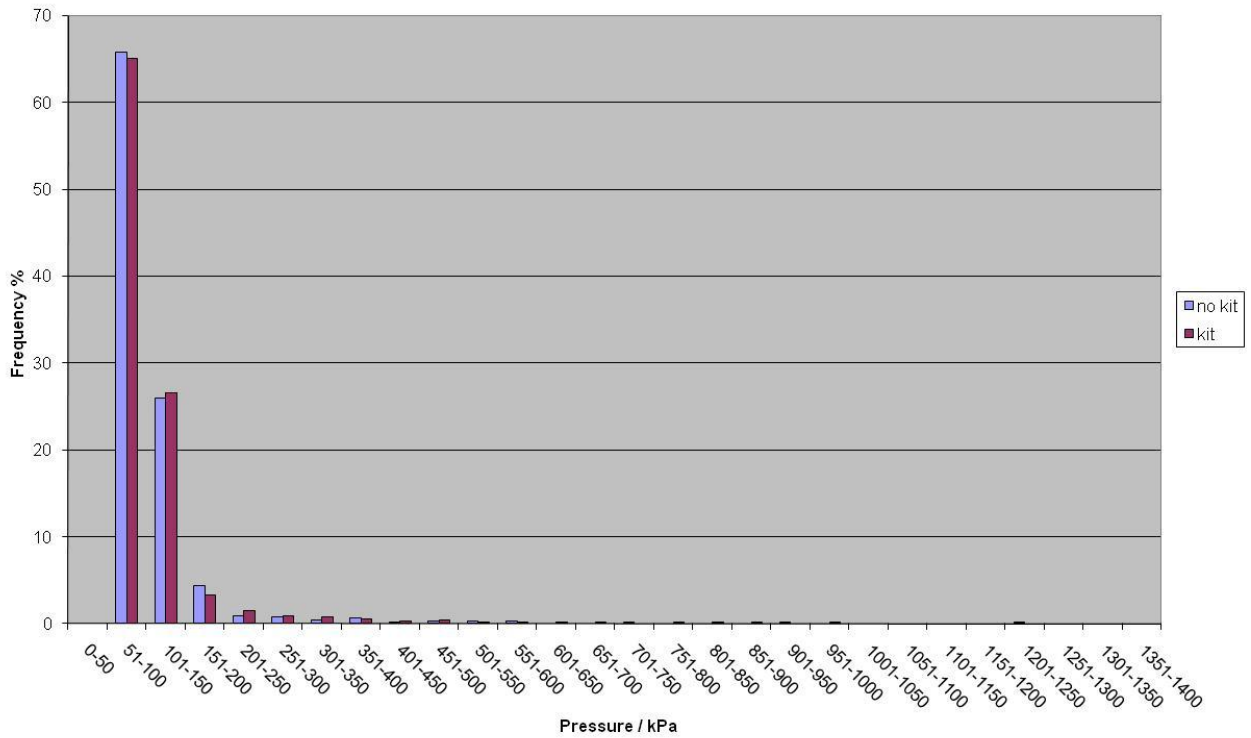

Figure 70 – Peak pressure distribution recorded for the left knee during the assault exercise performed in the laboratory by Subject A.

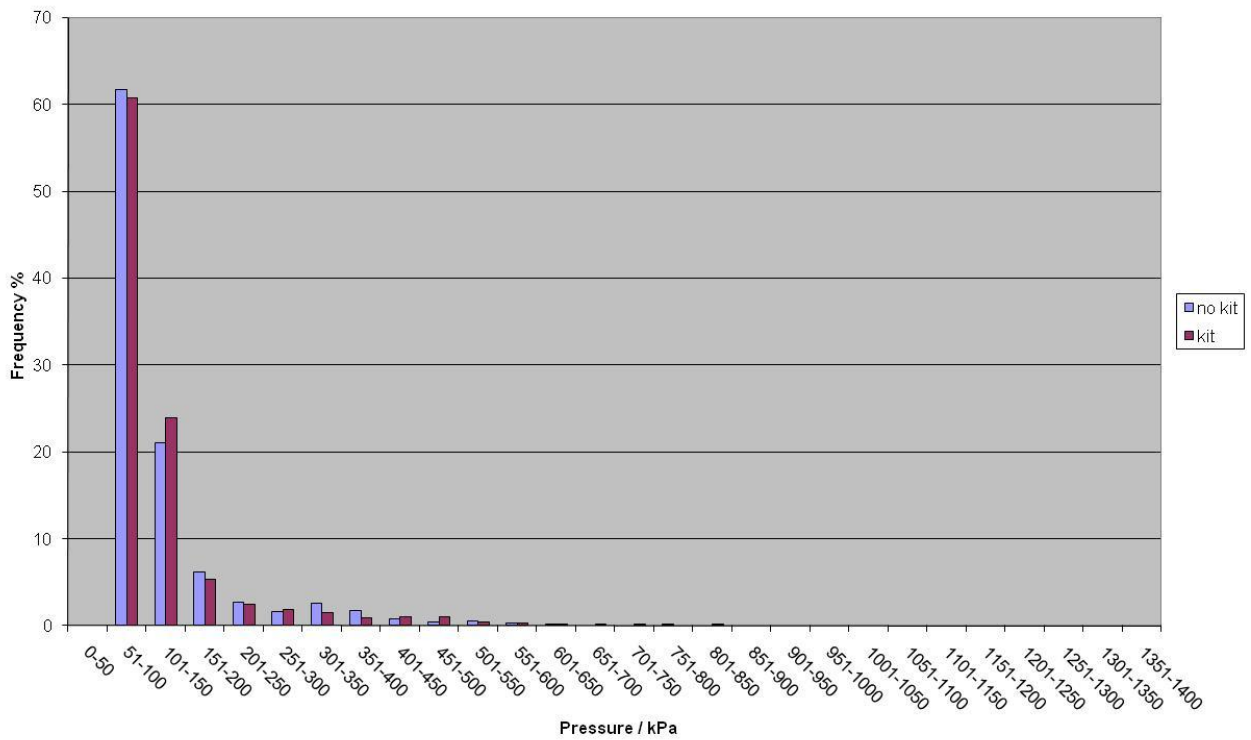

Figure 71 – Peak pressure distribution recorded for the right knee during the assault exercise performed on grassland by Subject A.

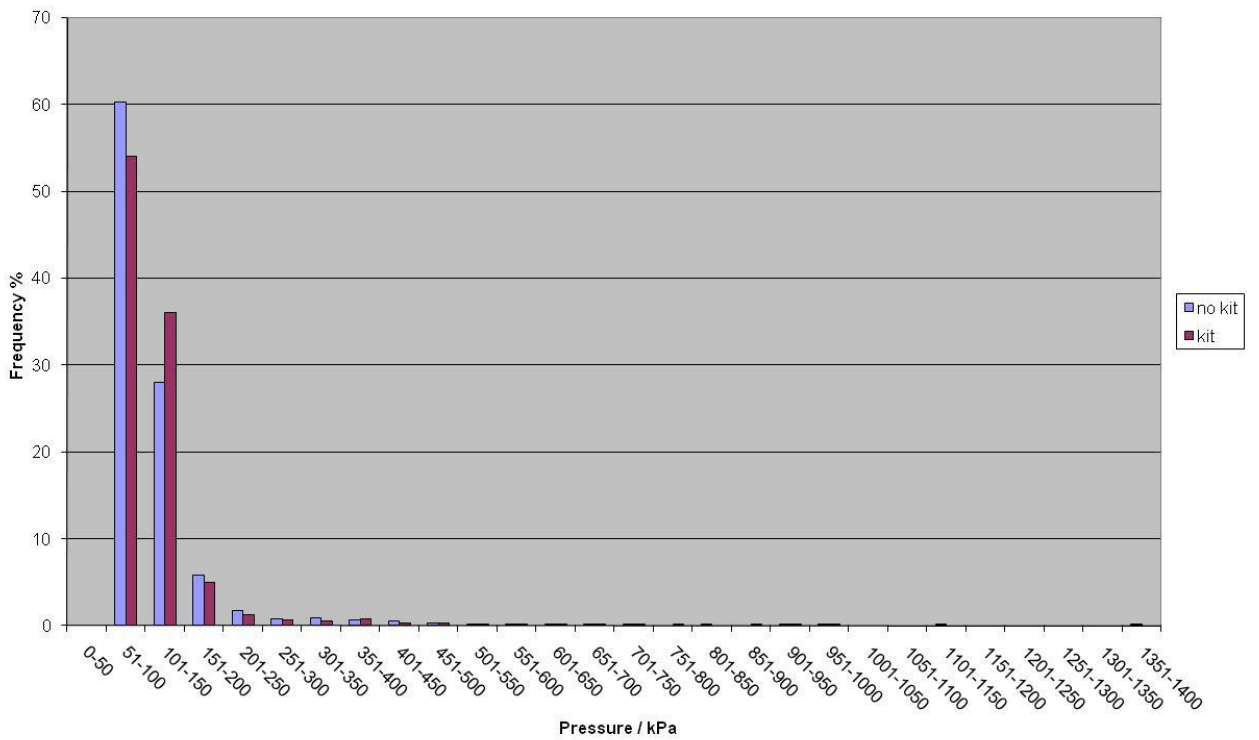

Figure 72 – Peak pressure distribution recorded for the right knee during the assault exercise performed in the laboratory by Subject A.

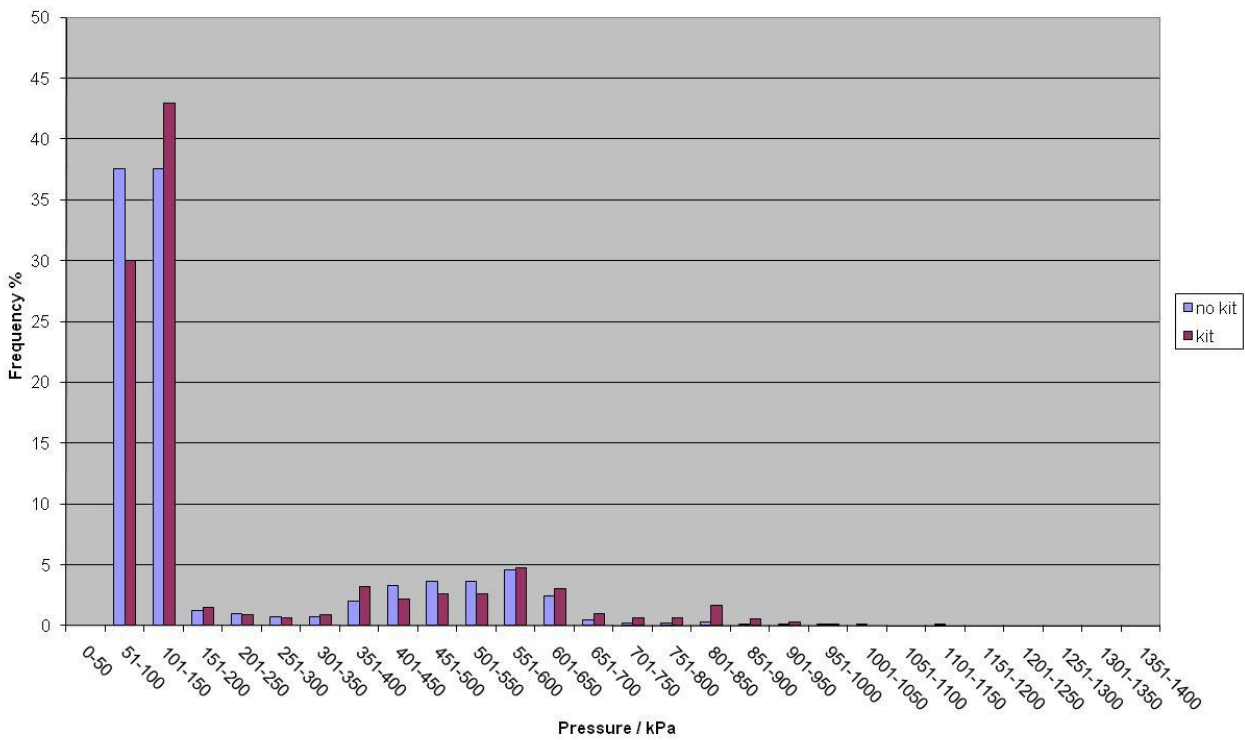

Figure 73 – Peak pressure distribution recorded for the left elbow during the assault exercise performed on grassland by Subject B.

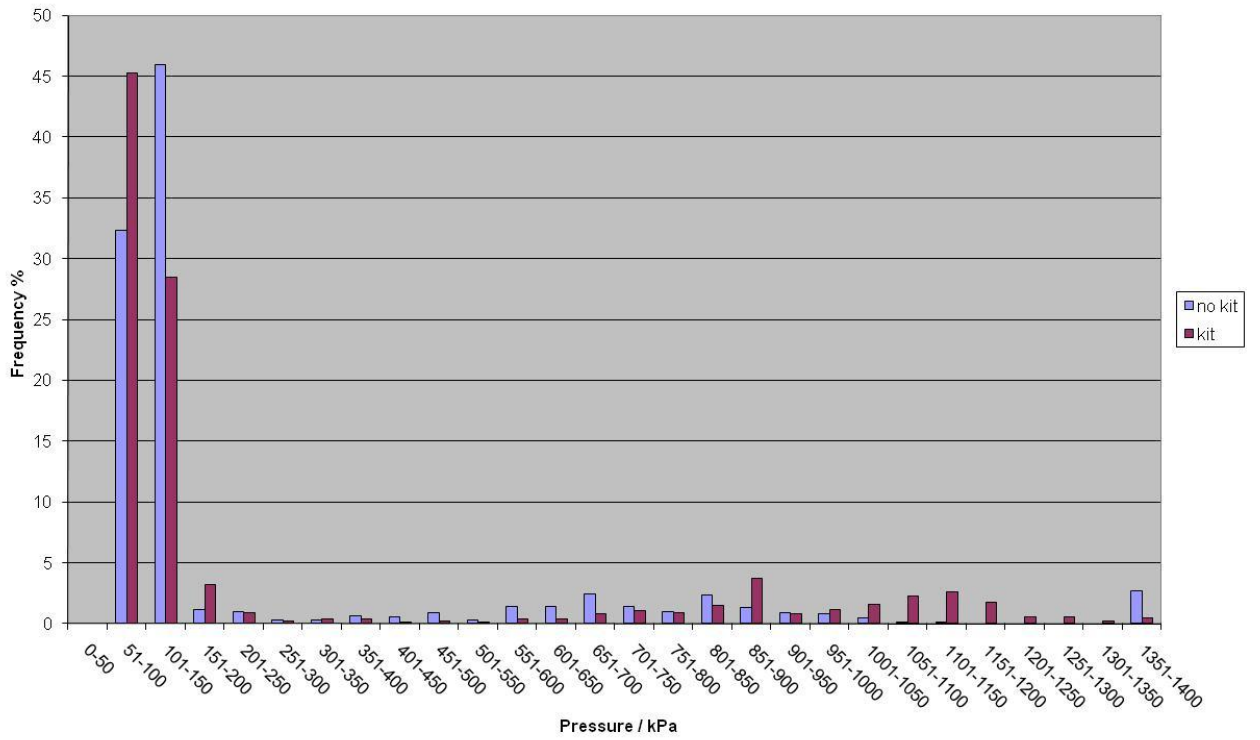

Figure 74 - Peak pressure distribution recorded for the left elbow during the assault exercise performed in the laboratory by Subject B.

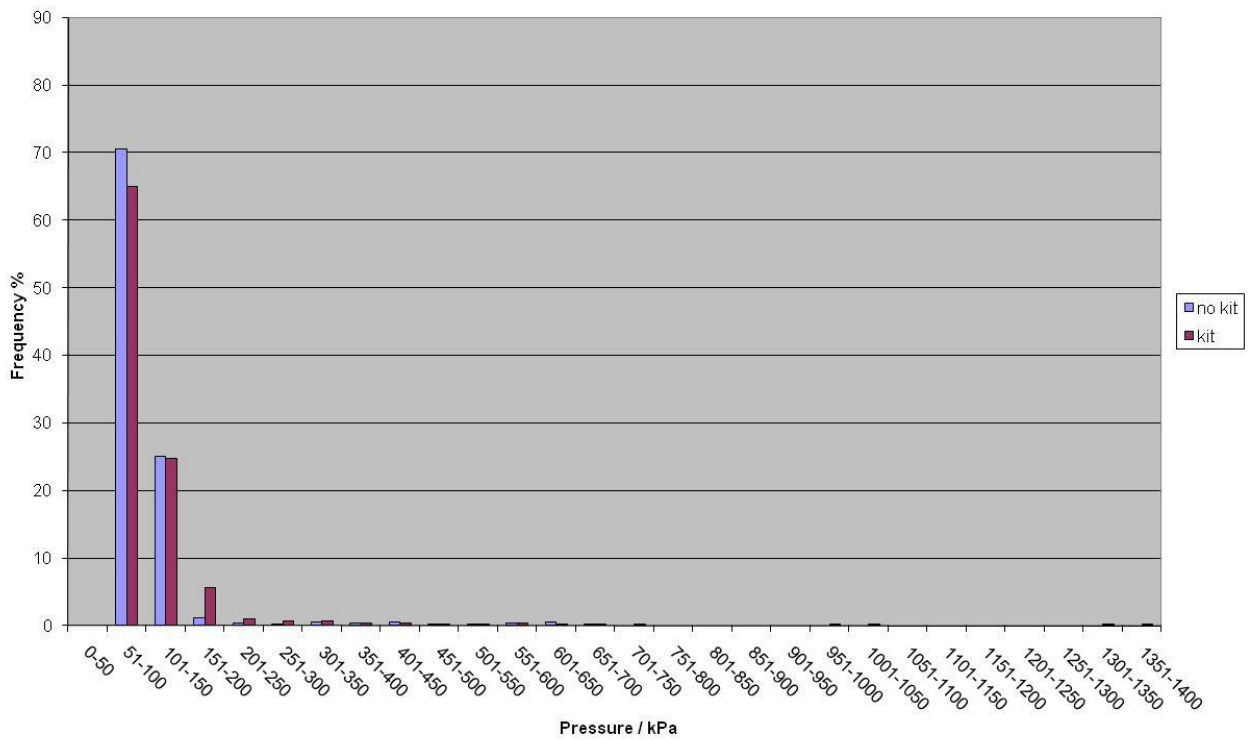

Figure 75 – Peak pressure distribution recorded for the left knee during the assault exercise performed on grassland by Subject B.

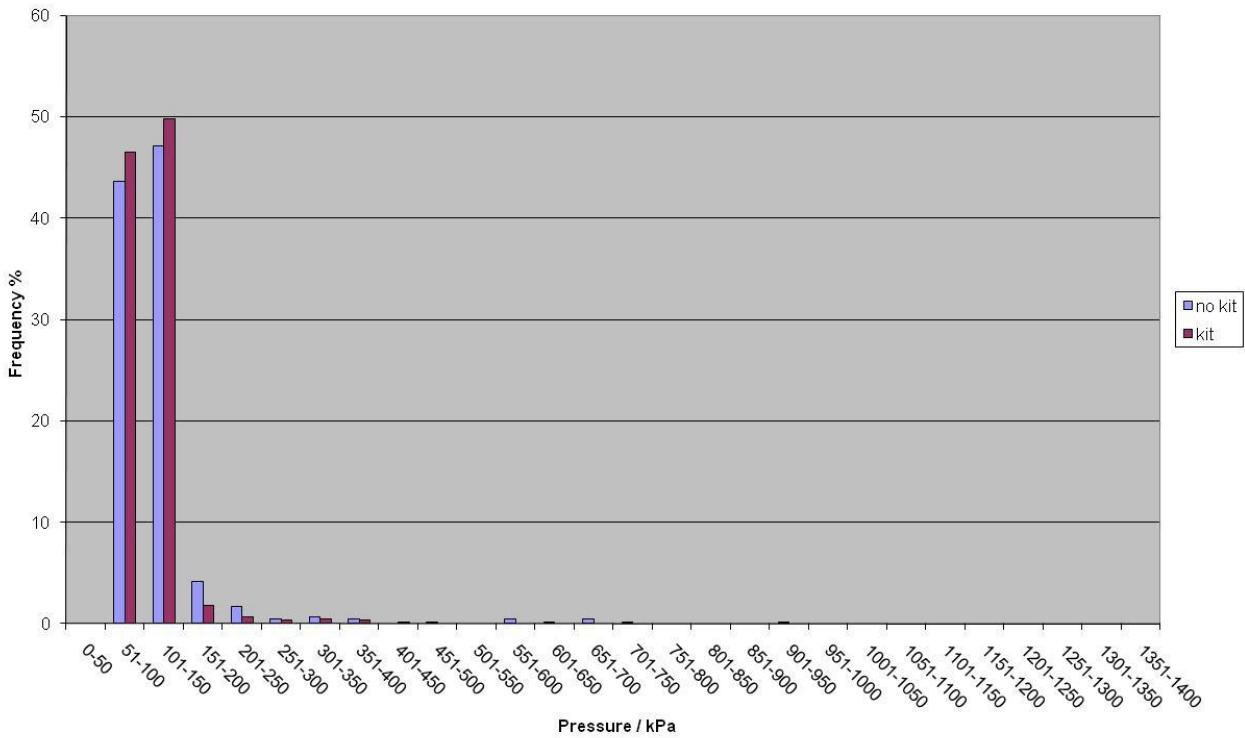

Figure 76 – Peak pressure distribution recorded for the left knee during the assault exercise performed in the laboratory by Subject B.

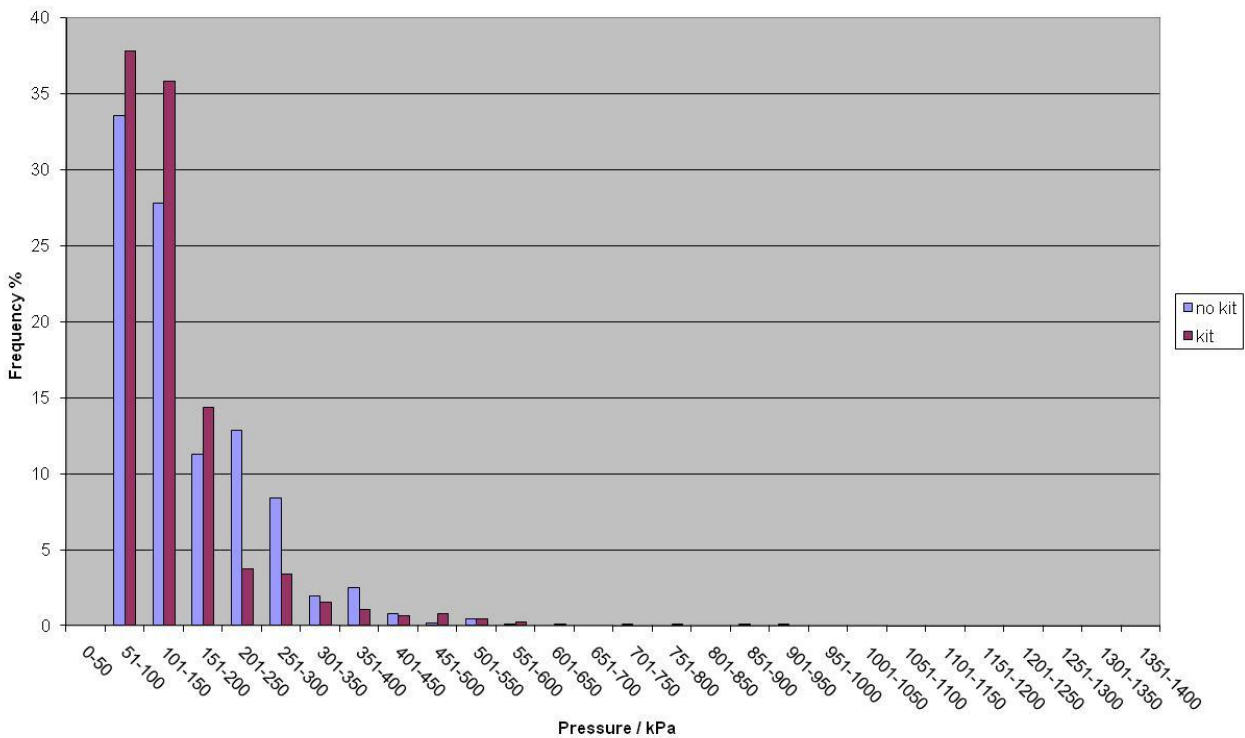

Figure 77 – Peak pressure distribution recorded for the right knee during the assault exercise performed on grassland by Subject B.

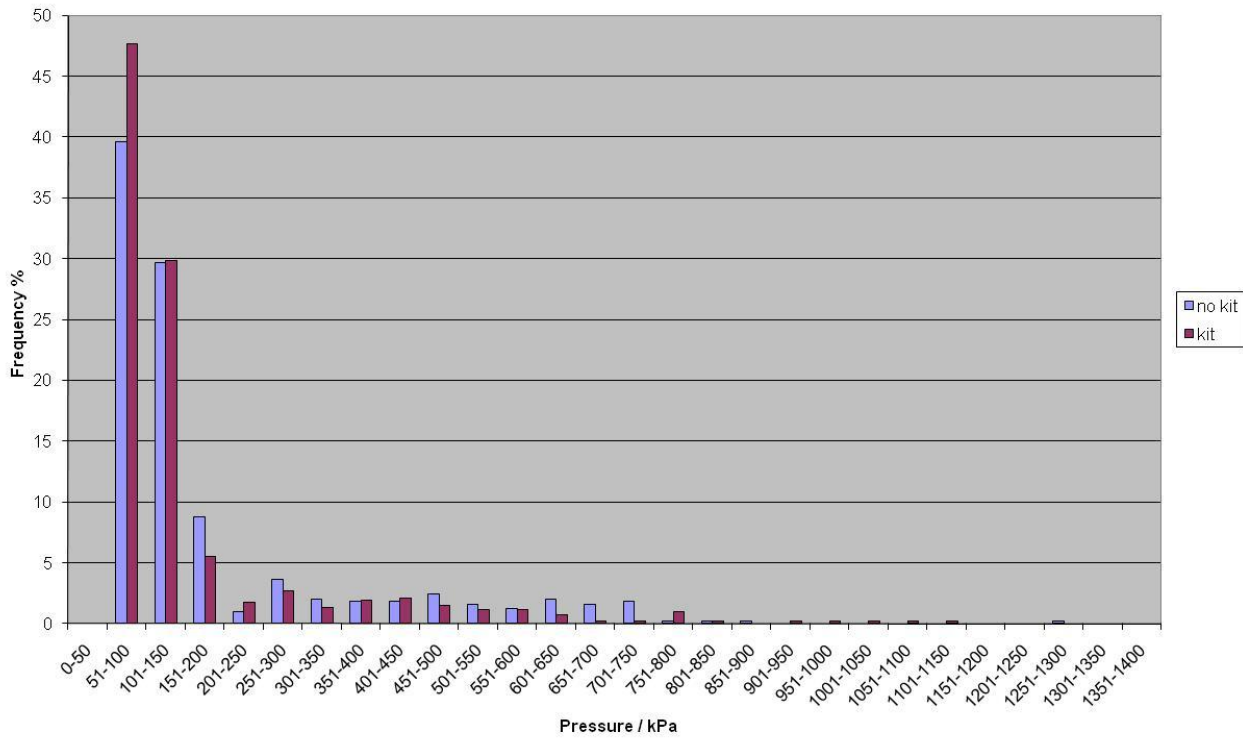

Figure 78 – Peak pressure distribution recorded for the right knee during the assault exercise performed in the laboratory by Subject B.

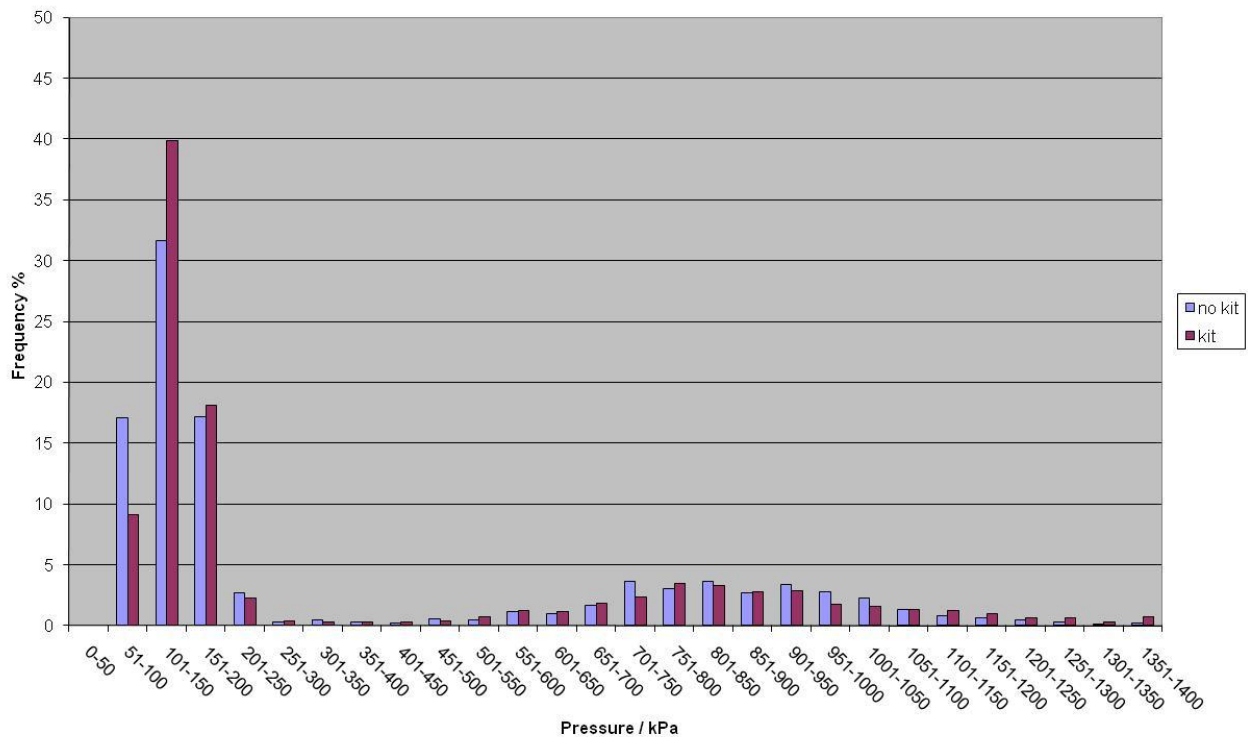

Figure 79 – Peak pressure distribution recorded for the left elbow during the assault exercise performed in the laboratory by Subject C.

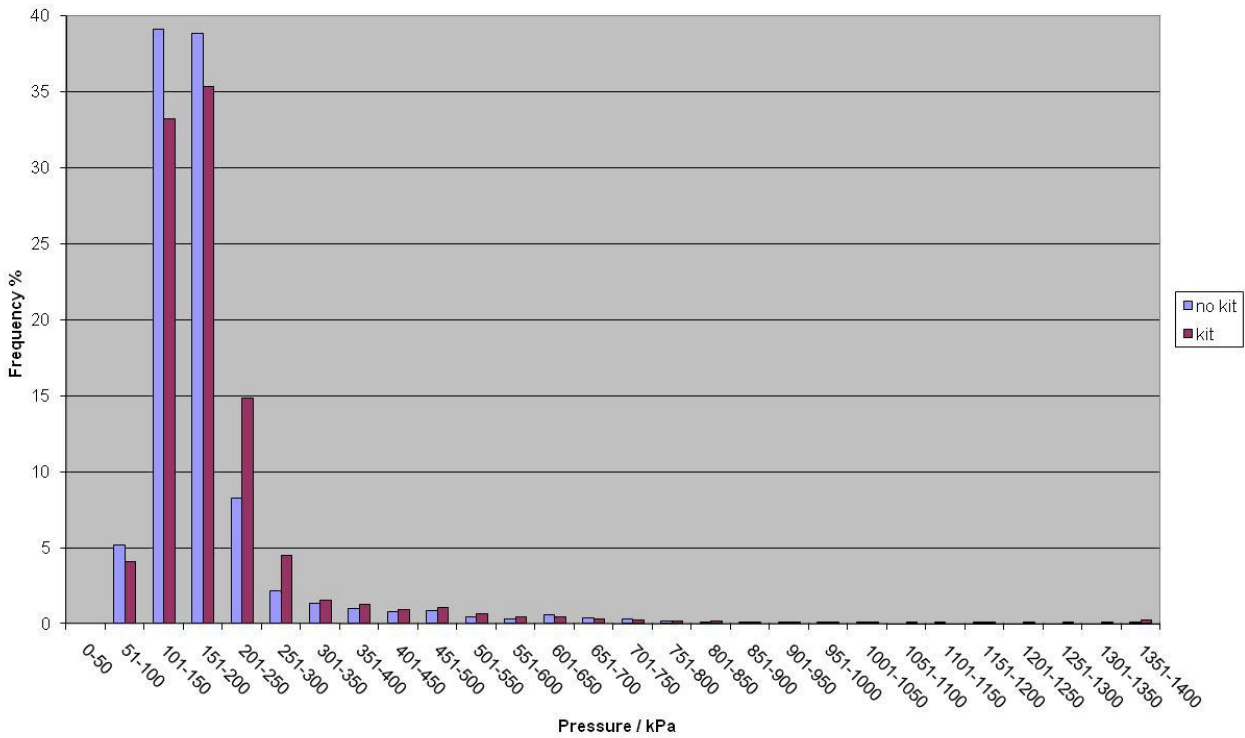

Figure 80 – Peak pressure distribution recorded for the left knee during the assault exercise performed in the laboratory by Subject C.

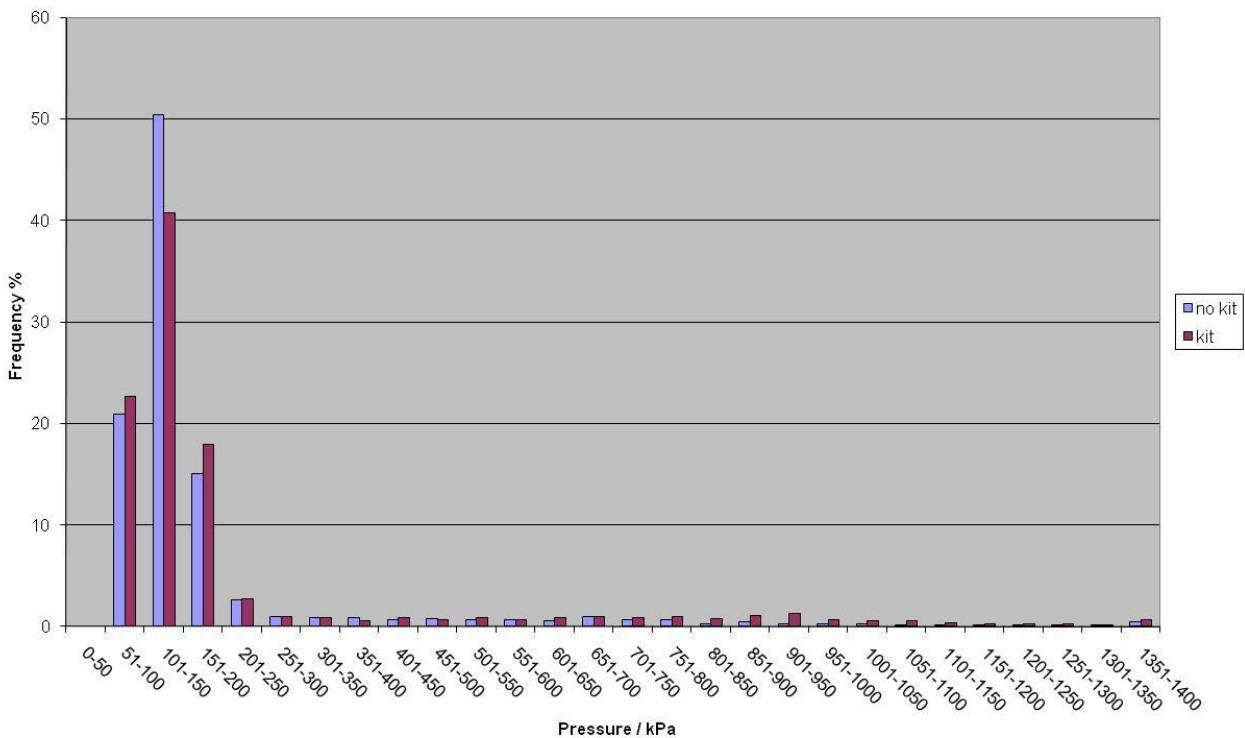

Figure 81 - Peak pressure distribution recorded for the right knee during the assault exercise performed in the laboratory by Subject C.

12.2 Leopard Crawl

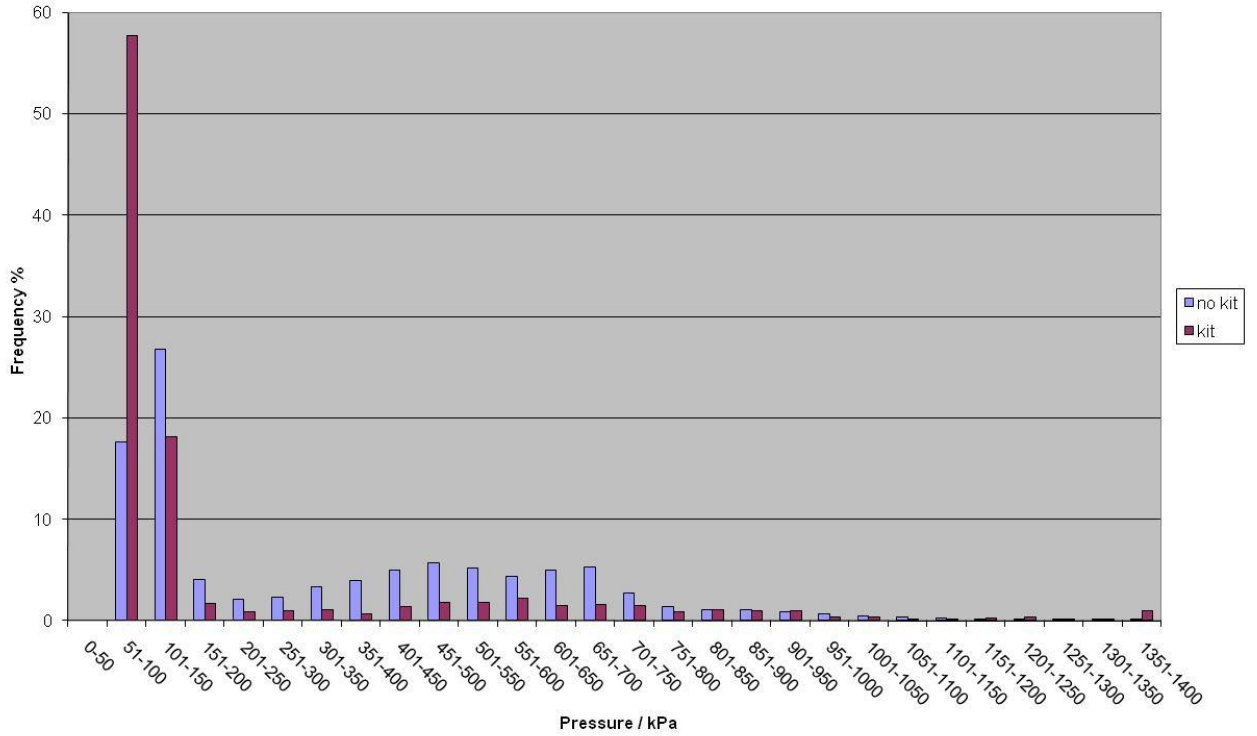

Figure 82 – Peak pressure distribution recorded for the left elbow during the leopard crawl performed on grassland by Subject A.

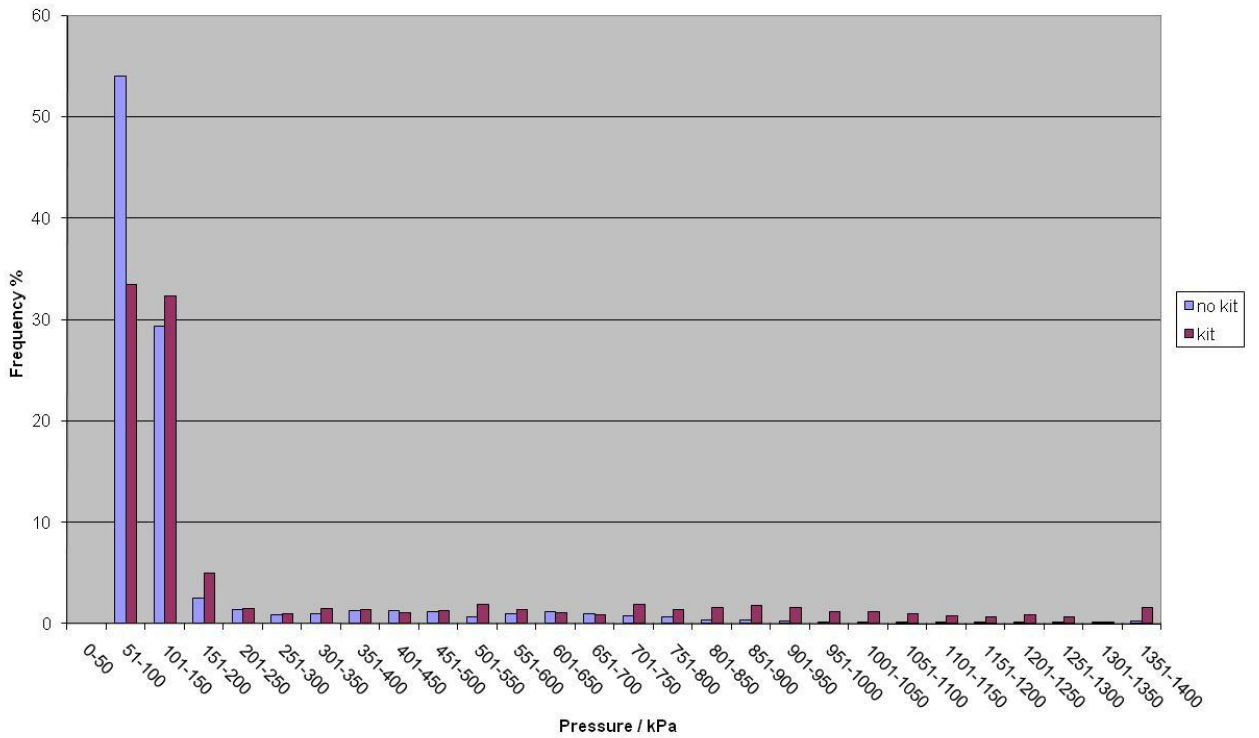

Figure 83 – Peak pressure distribution recorded for the left elbow during the leopard crawl performed in the laboratory by Subject A.

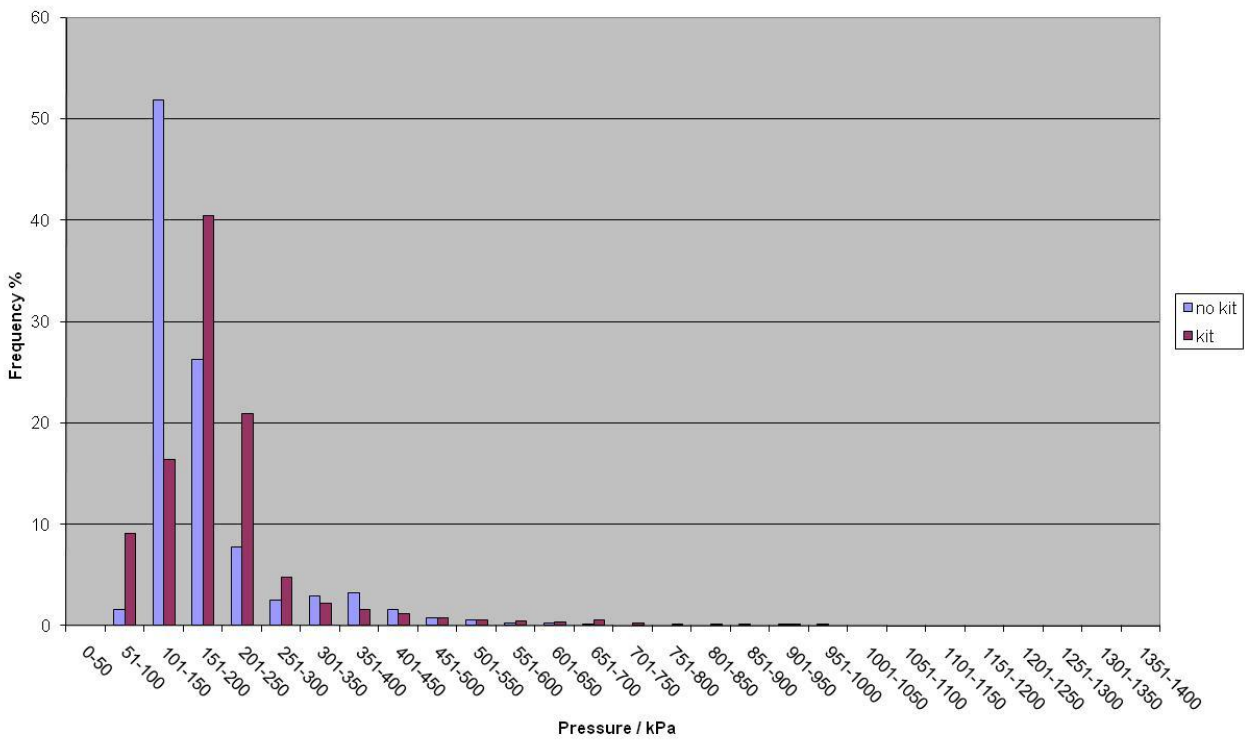

Figure 84 – Peak pressure distribution recorded for the right elbow during the leopard crawl performed on grassland by Subject A.

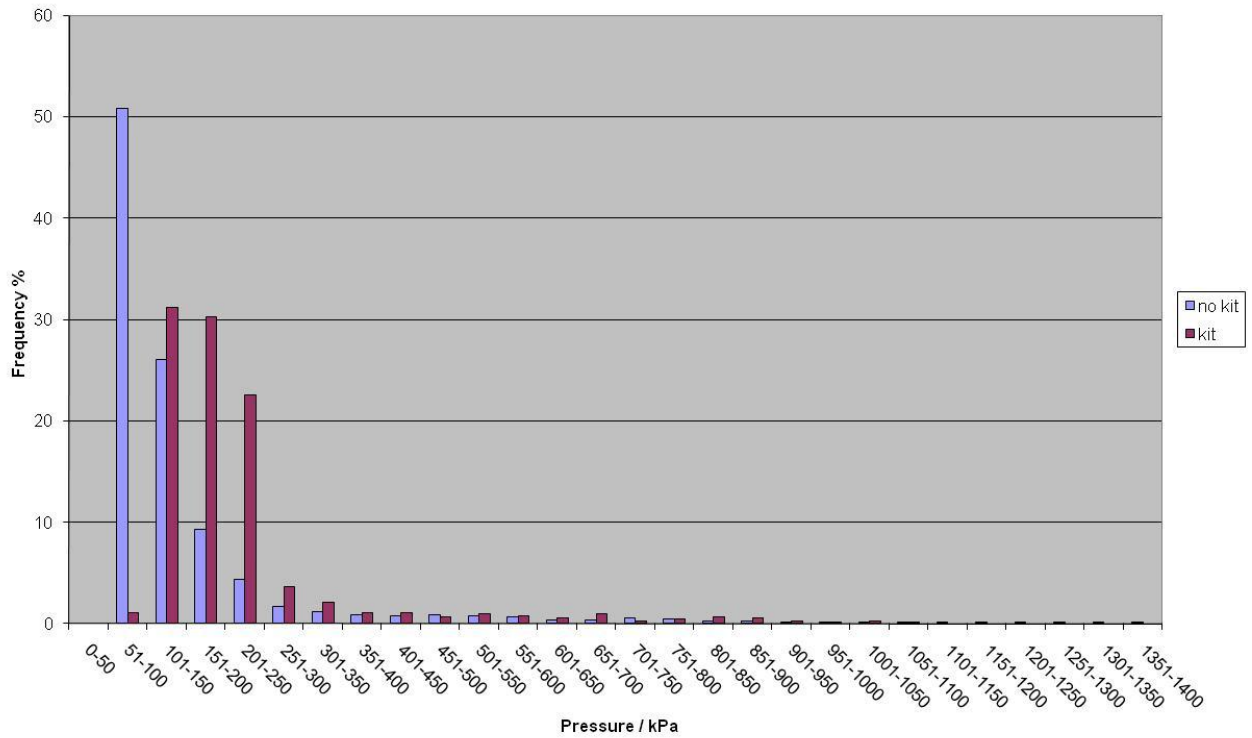

Figure 85 – Peak pressure distribution recorded for the right elbow during the leopard crawl performed in the laboratory by Subject A.

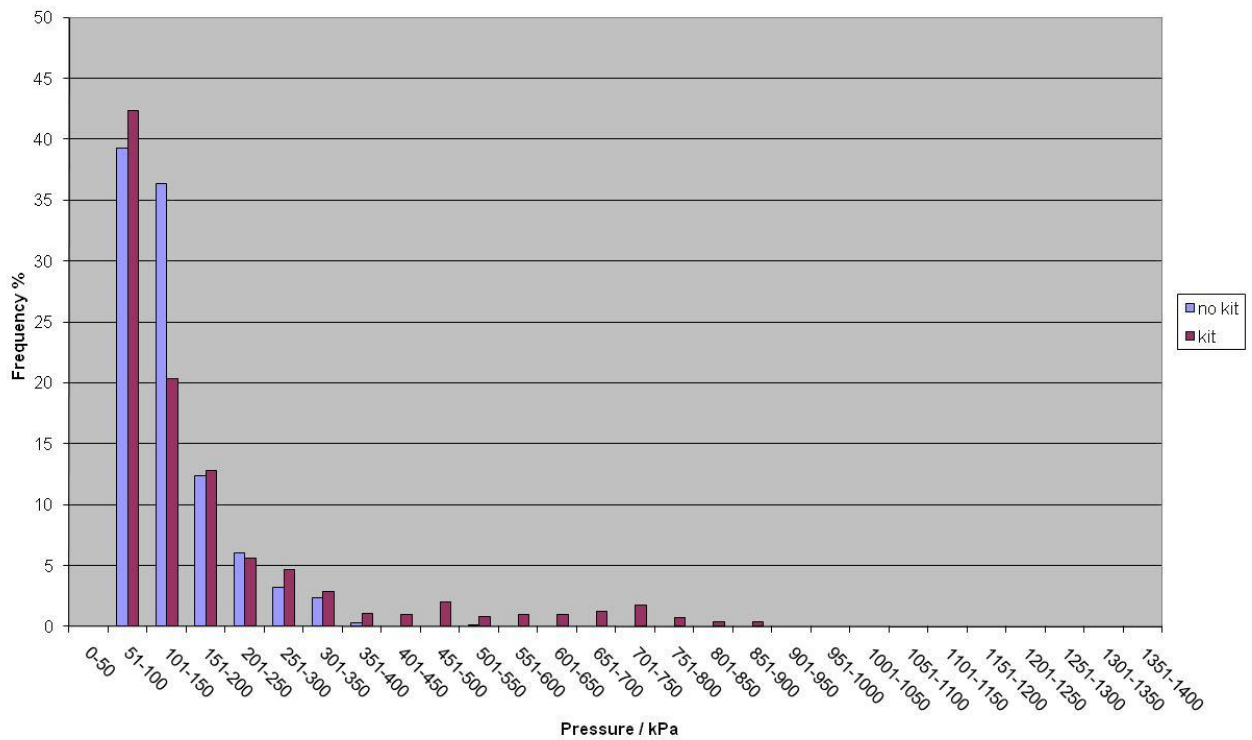

Figure 86 – Peak pressure distribution recorded for the left knee during the leopard crawl performed on grassland by Subject A.

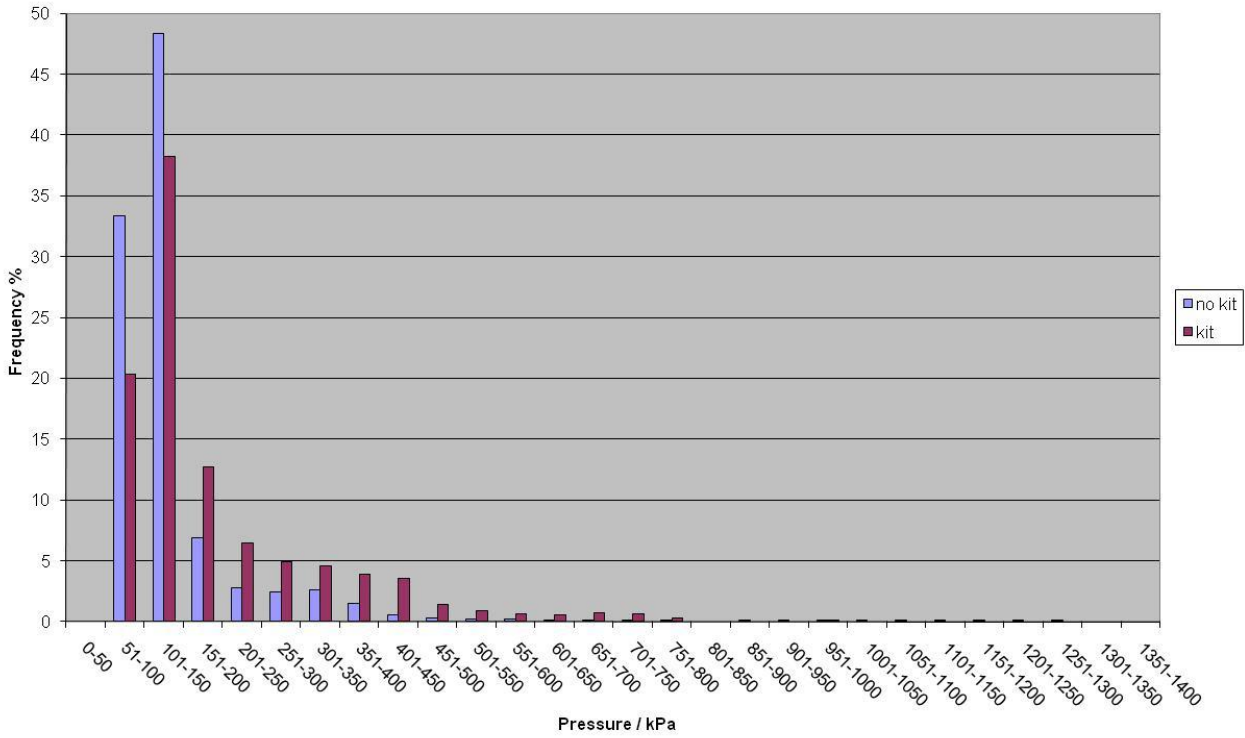

Figure 87 – Peak pressure distribution recorded for the left knee during the leopard crawl performed in the laboratory by Subject A.

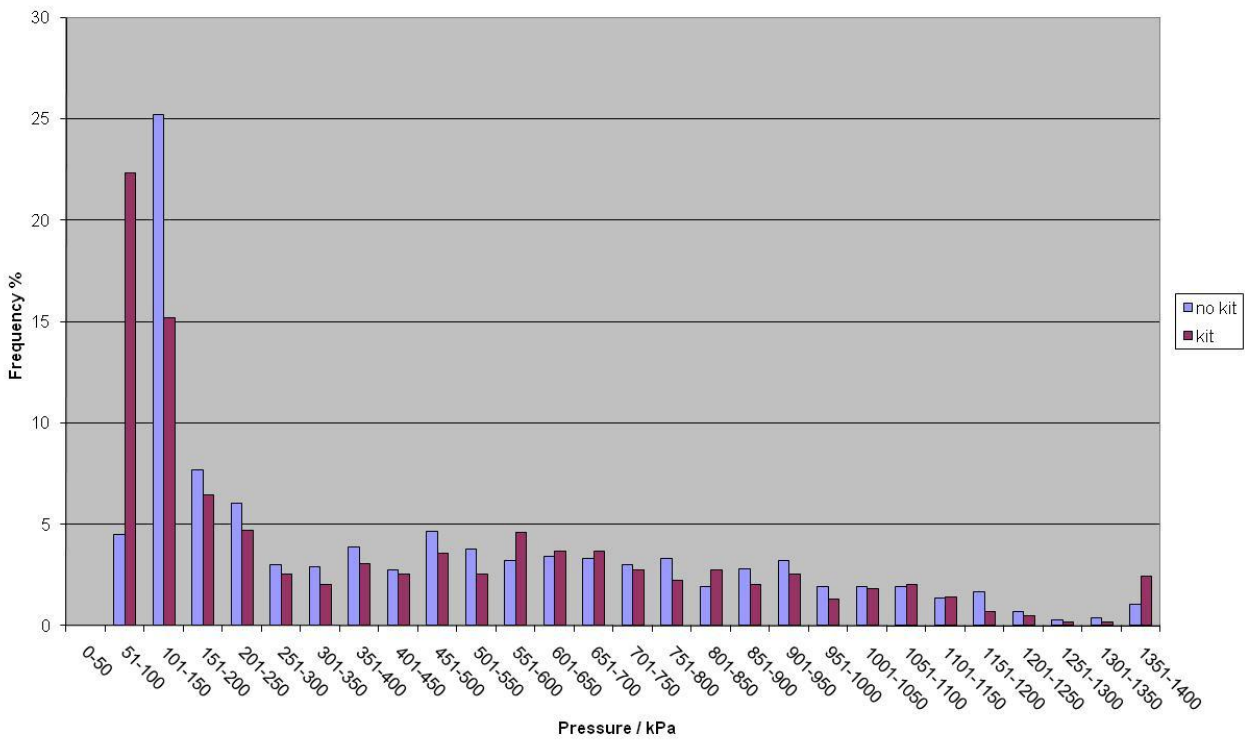

Figure 88 – Peak pressure distribution recorded for the left elbow during the leopard crawl performed on grassland by Subject B.

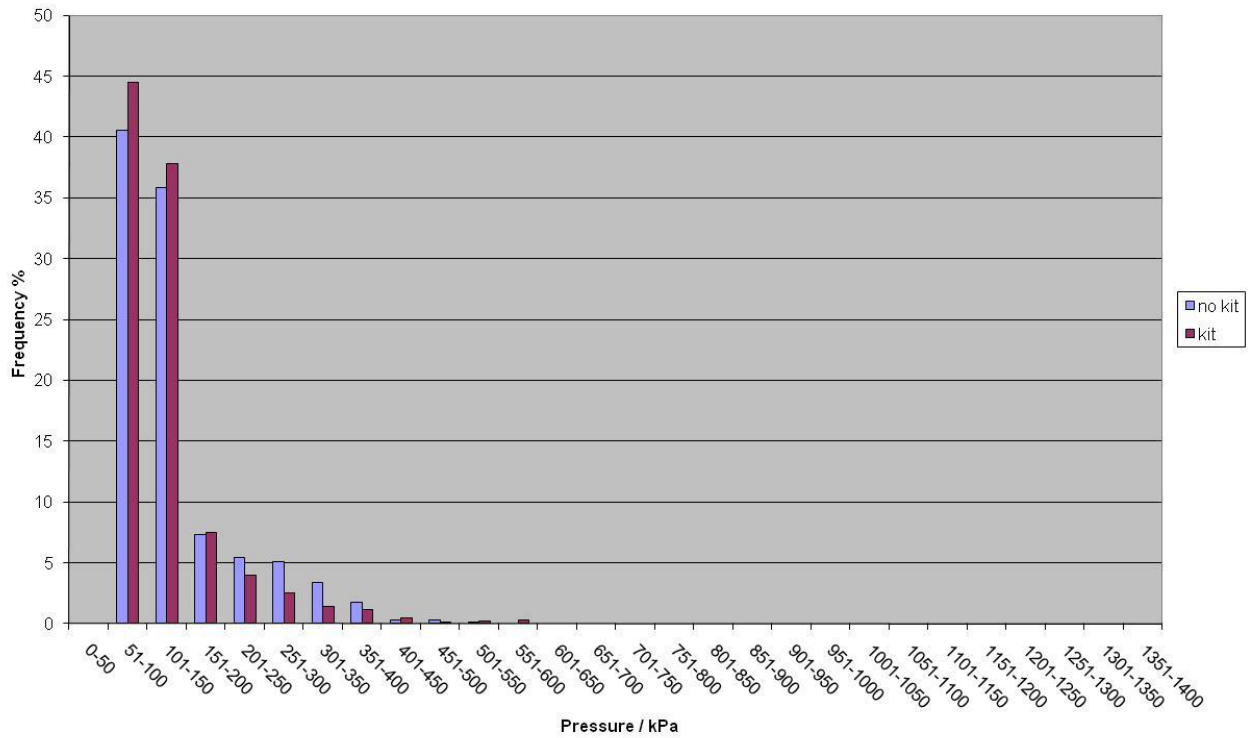

Figure 89 – Peak pressure distribution recorded for the left knee during the leopard crawl performed on grassland by Subject B.

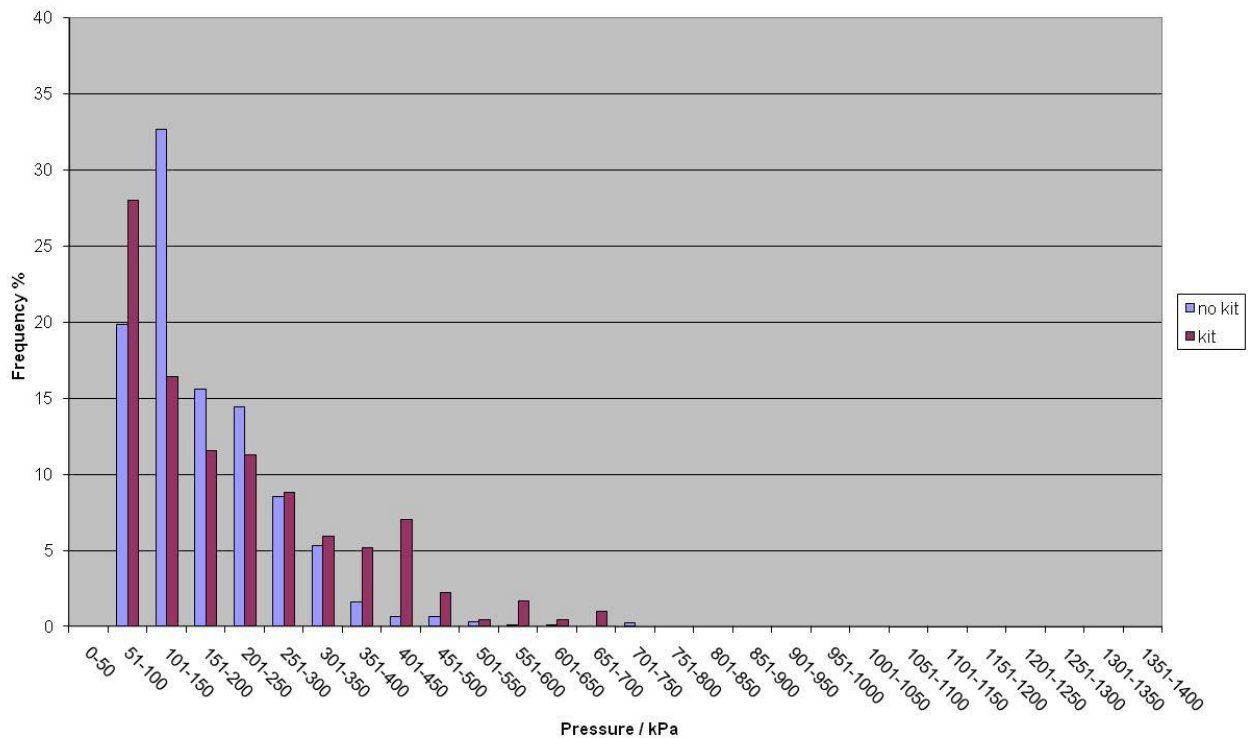

Figure 90 - Peak pressure distribution recorded for the right knee during the leopard crawl performed on grassland by Subject B.

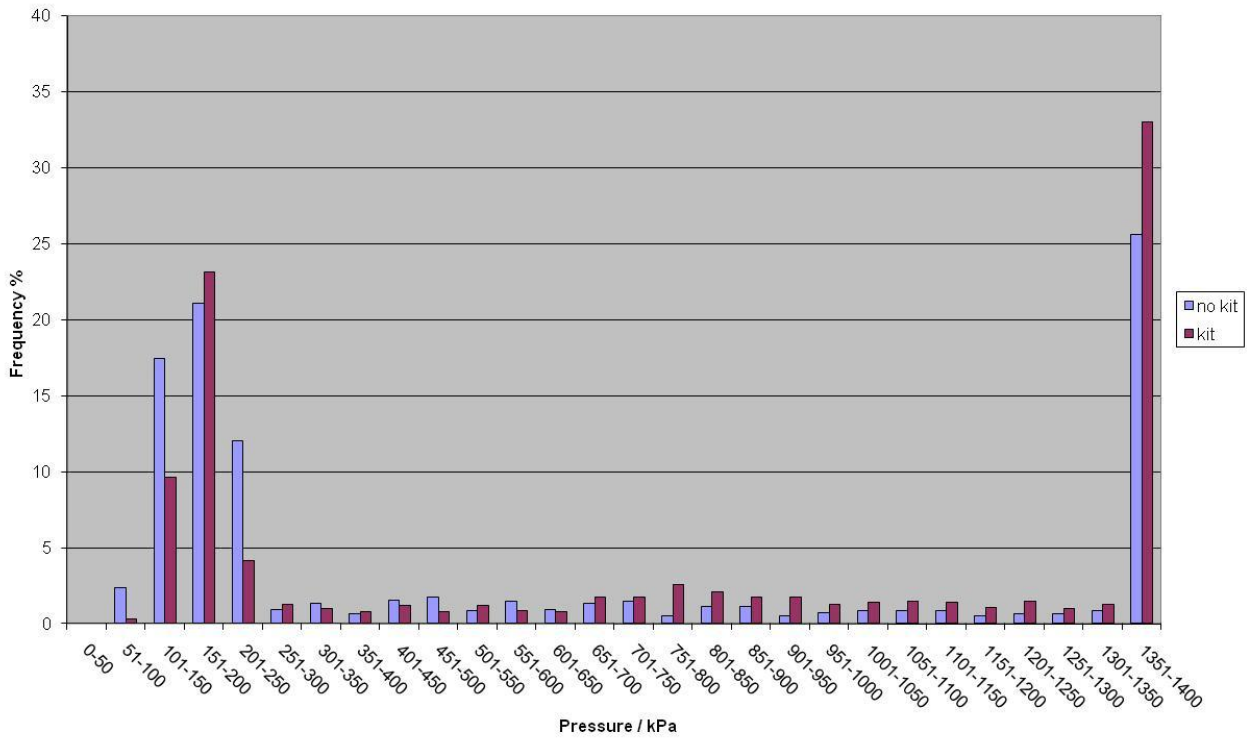

Figure 91 – Peak pressure distribution recorded for the left elbow during the leopard crawl performed in the laboratory by Subject C.

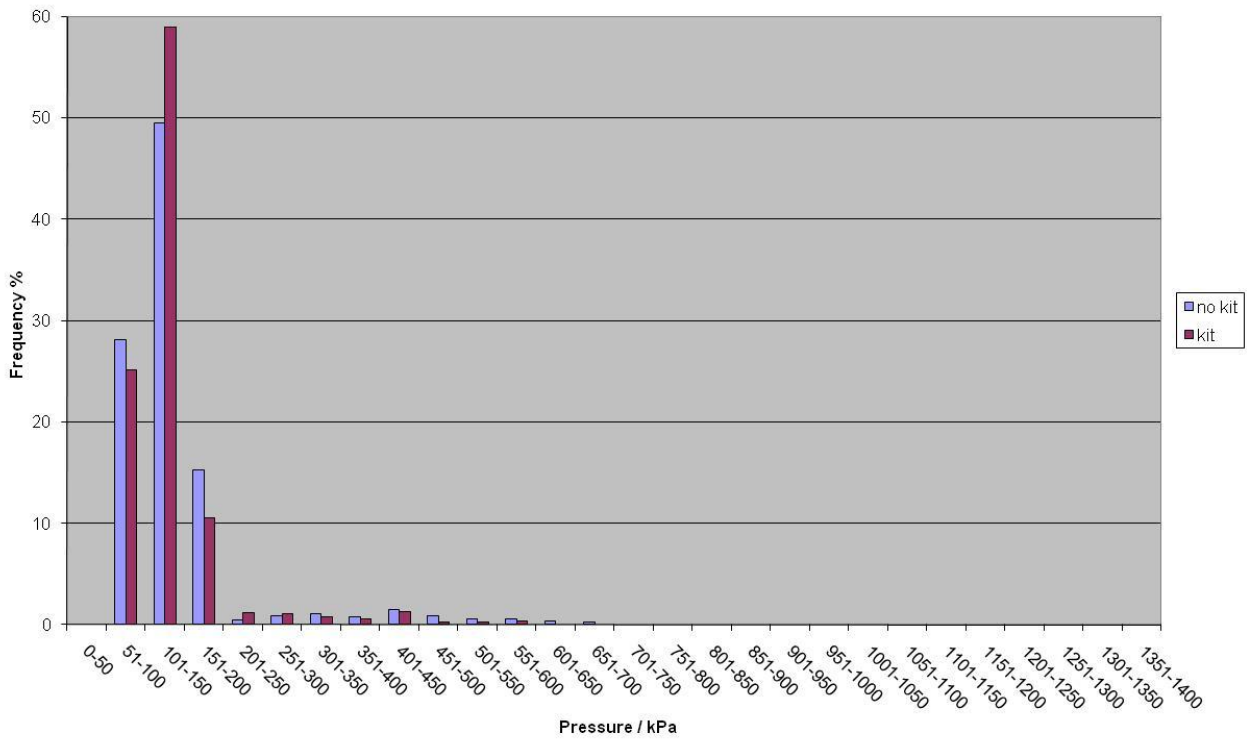

Figure 92 – Peak pressure distribution recorded for the left knee during the leopard crawl performed in the laboratory by Subject C.

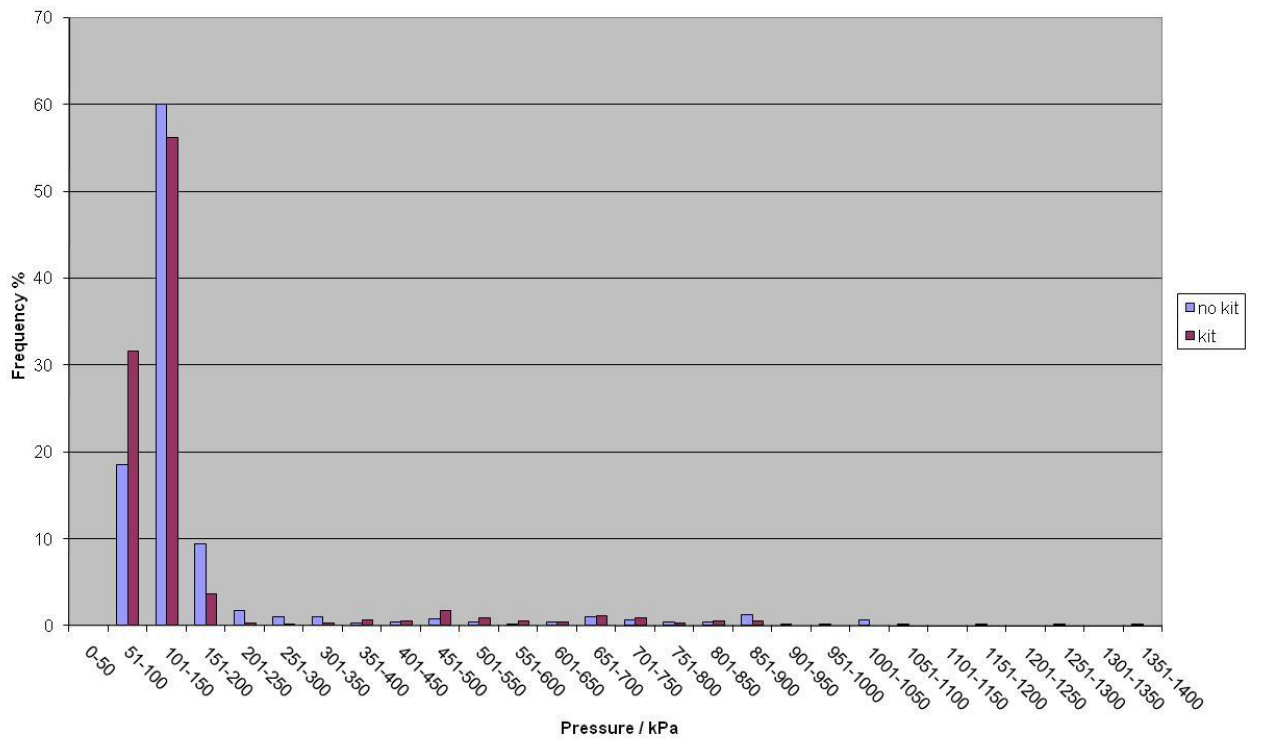

Figure 93 – Peak pressure distribution recorded for the right knee during the leopard crawl performed in the laboratory by Subject C.

**UNCLASSIFIED**

INTENTIONALLY LEFT BLANK

**UNCLASSIFIED**

**Initial distribution**

**External**

DTRA  
DTRA  
DTRA

Dr Charles Bass  
Dr Salvatore Clamenti  
Lt Col Tilghman Rittenhouse

**Copy No**

1 & electronic  
1 & electronic  
1 & electronic

**Internal**

Project Manager  
GCA CBP & SP  
Author

Mrs Tina Robinson-Collins  
Dr Colin Willis  
Dr Mark Summers

electronic  
electronic  
1 & electronic

**UNCLASSIFIED**

INTENTIONALLY LEFT BLANK

**UNCLASSIFIED**

## Report Documentation Form

A copy of this form is to be completed by the principal author for all Dstl reports. When complete, it is to be bound as the last numbered pages of the finished report.

1. Originators Report Number incl. Version No		Dstl/TR53405	
2. Report Protective Markings and any other markings e.g. Caveats, Descriptors, Privacy markings UNCLASSIFIED			
3. Title of Report		Pressure Sensing Suit	
4. Title Protective Markings incl. any Caveats		UNCLASSIFIED	
5. Authors MJ Summers			
6. Originator's Name and Address Dr M Summers Dstl Porton Down Salisbury, Wiltshire SP4 0JQ UK		7. DOD Sponsor Name and Address Dr C Bass Protection CAPO Defense Threat Reduction Agency DTRA 8752 John J Kingman Rd Stop 6201, Fort Belvoir, VA 22060-6201, USA	
8. DOD Contract number and period covered		W911NF-06-C-0040 May 07 – Feb 11	
9. Other Report Nos. N/A			
10. Date of Issue February 2011	11. Pagination 139	12. No. of References 7	
13. Abstract (A brief (approximately 150 words) factual summary of the report)  A prototype pressure sensing suit capability was developed successfully that allows real-time pressure data to be captured whilst performing activities in the field that cannot be readily simulated in the laboratory. Three military subjects were used to collect representative pressure data from a series of standard battlefield-type activities. The impact of terrain and wearing additional combat equipment was also investigated.  The data obtained from this study indicated that the mean pressures experienced at the elbows and knees ranged between 90 kPa to 160 kPa, whereas the remaining locations fell between 40 kPa and 60 kPa. Extremely high peak pressures were recorded up to 1379 kPa; however, generally these pressures were encountered for less than 2% over the duration of the exercise.			
14. Abstract Protective Marking including any Caveats UNCLASSIFIED			
15. Keywords/Descriptors (Authors may provide terms or short phrases which identify concisely the technical concepts, platforms, systems etc. covered in the report.			

Pressure mapping, liquid protection

16. Report Announcement (refers to title/abstract being included in accessions lists e.g. Defence Reports Abstracts)

Announcement of this report is UNLIMITED

If there are limitations on the announcement of this report please indicate below the groups to whom it can be announced (more than one if required)

- Can be announced to MOD and its Agencies
- Can be announced to UK Defence Contractors
- Can be announced to Overseas Defence Departments
- Other (please specify)

17. Report Availability

- UNLIMITED distribution
- No Release without approval of the Release Authority



If the above do not apply, please indicate below the groups to whom the report may be released upon request without further Need-To-Know checks.

- Can be released to MOD and its Agencies
- Can be released to other UK Government Departments
- Can be released to UK Defence Contractors
- Can be released to Overseas Defence Departments
- Other (please specify)

18. Downgrading Instructions (check as appropriate)

- This report may be automatically downgraded to \_\_\_\_\_ after \_\_\_\_\_ years
- This report may be reviewed 5 years after publication

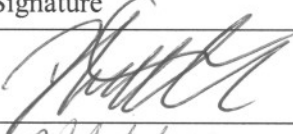
19. Authorisation (Complete as applicable)

	Name	Signature	Date
Group Leader	Mr. David Southgate		14/02/2011
Project Manager	Mrs. Tina Robinson-Collins		14 Feb 2011
Technical Reviewer	Dr. Colin Willis		14/2/11

When complete the form is to be bound into the report to which it refers and is to form the last numbered pages of the report. Dstl Knowledge Services, Porton Down will enter an abstract and other details onto the relevant report management systems.

**UNCLASSIFIED**

**INTENTIONALLY LEFT BLANK**

**UNCLASSIFIED**