

# AFOSR DURIP FA9550-09-1-0496

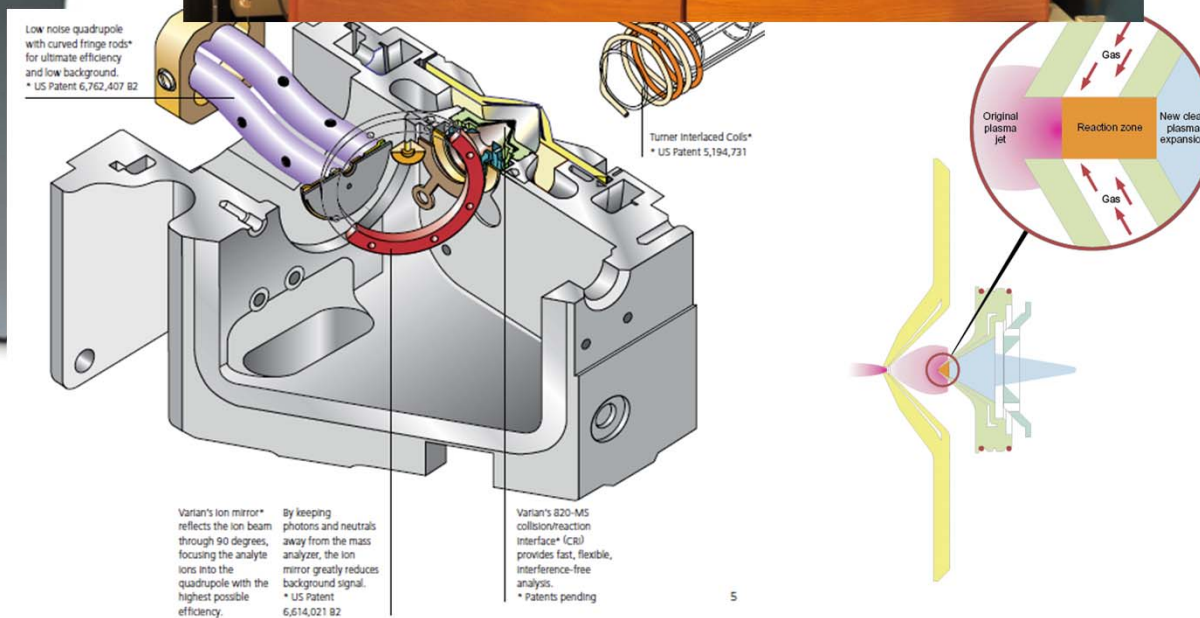
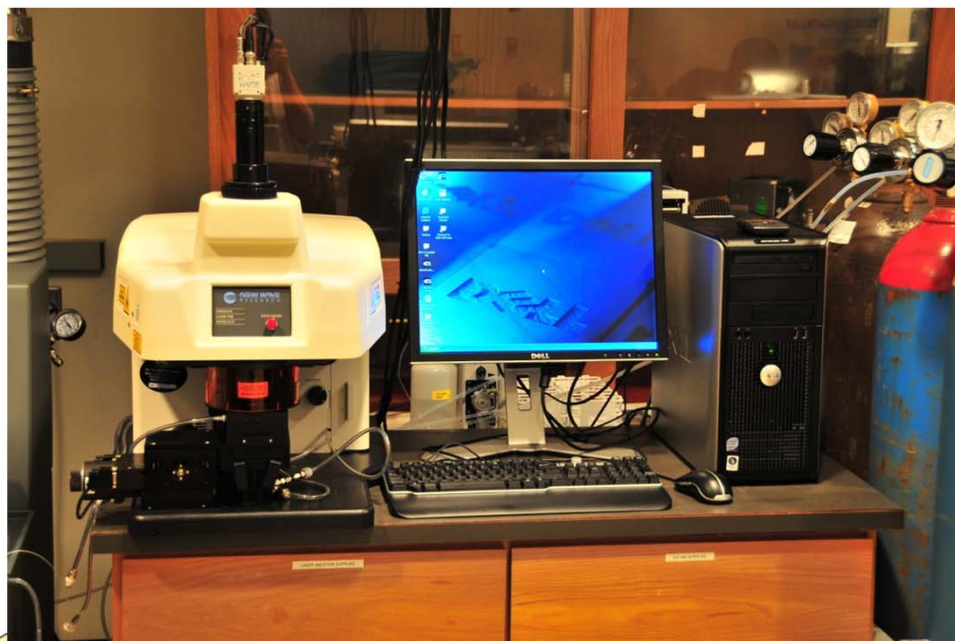

## Report Documentation Page

*Form Approved*  
OMB No. 0704-0188

Public reporting burden for the collection of information is estimated to average 1 hour per response, including the time for reviewing instructions, searching existing data sources, gathering and maintaining the data needed, and completing and reviewing the collection of information. Send comments regarding this burden estimate or any other aspect of this collection of information, including suggestions for reducing this burden, to Washington Headquarters Services, Directorate for Information Operations and Reports, 1215 Jefferson Davis Highway, Suite 1204, Arlington VA 22202-4302. Respondents should be aware that notwithstanding any other provision of law, no person shall be subject to a penalty for failing to comply with a collection of information if it does not display a currently valid OMB control number.

1. REPORT DATE <b>24 DEC 2010</b>	2. REPORT TYPE <b>Final</b>	3. DATES COVERED <b>15-06-2009 to 14-06-2010</b>	
4. TITLE AND SUBTITLE <b>DURIP - Acquisition of an Inductively-Coupled Plasma Mass Spectrometer with Laser Ablation Source for Surface Characterization.</b>		5a. CONTRACT NUMBER <b>FA9550-09-1-0496</b>	
		5b. GRANT NUMBER	
		5c. PROGRAM ELEMENT NUMBER	
6. AUTHOR(S) <b>Guido Verbeck</b>		5d. PROJECT NUMBER	
		5e. TASK NUMBER	
		5f. WORK UNIT NUMBER	
7. PERFORMING ORGANIZATION NAME(S) AND ADDRESS(ES) <b>University of North Texas, 1155 Union Circle # 305250, Denton, TX, 76203-5017</b>		8. PERFORMING ORGANIZATION REPORT NUMBER <b>6B783</b>	
9. SPONSORING/MONITORING AGENCY NAME(S) AND ADDRESS(ES) <b>AFOSR, 875 North Randolph Street, Suite 325, Arlington, VA, 22203</b>		10. SPONSOR/MONITOR'S ACRONYM(S)	
		11. SPONSOR/MONITOR'S REPORT NUMBER(S) <b>AFRL-OSR-VA-TR-2011-0221</b>	
12. DISTRIBUTION/AVAILABILITY STATEMENT <b>Approved for public release; distribution unlimited</b>			
13. SUPPLEMENTARY NOTES			
14. ABSTRACT <b>The instrument and projects listed in the brief have been properly installed and executed. The 820 ICP-MS is a universal 90 degree quadrupole mass spectrometer equipped with a collision reaction interface (CRI) front end. The CRI allows low interference which reduces common polyatomic interferences on As, Se, Cr, V and Fe, thus achieving lower detection limits in the plasma, especially for samples with complex matrices. The CRI increases sensitivity and lowers time to acquisition based on the principals that collision dissociation occurs prior to mass selection, eliminating the need for the CID optics in other ICP-MS. Laser Ablation for material characterization is produced from a New Wave (ESI) LS-213 Tempest Laser Ablation System. This is ideal for determining surface composition with ICP-MS. This instrument provided an excellent resource in our multiuser facility and the broad adoption of the ICP-MS technology in industry and academia meant that our students and postdocs can be trained in the most relevant analytical approaches for materials research.</b>			
15. SUBJECT TERMS <b>Softlanding, Preparative Mass Spectrometry, Coatings, Inductively-Coupled Plasma</b>			
16. SECURITY CLASSIFICATION OF:			17. LIMITATION OF ABSTRACT <b>Same as Report (SAR)</b>
a. REPORT <b>unclassified</b>	b. ABSTRACT <b>unclassified</b>	c. THIS PAGE <b>unclassified</b>	
			18. NUMBER OF PAGES <b>2</b>
19a. NAME OF RESPONSIBLE PERSON			



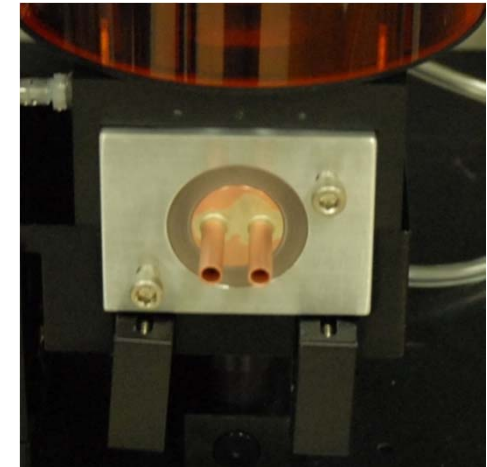
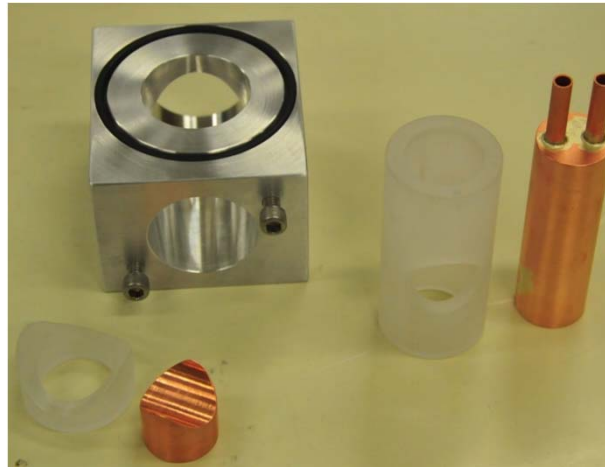
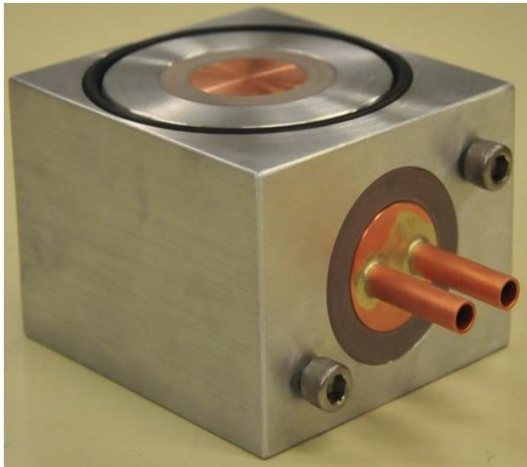

<sup>51</sup>V Temperature Dependent Signal

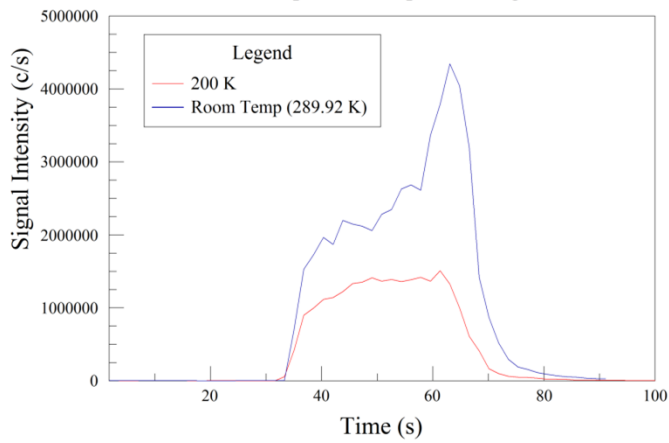

Signal RSD vs. Temperature

Isotope	288.92K	250 K	225 K	200 K
<sup>51</sup> V	17.49 %	21.31 %	12.76 %	3.18 %
<sup>63</sup> Cu	17.92 %	8.05 %	12.42 %	4.32 %

V51 Calibration Curve

Calibration Curve 200 K

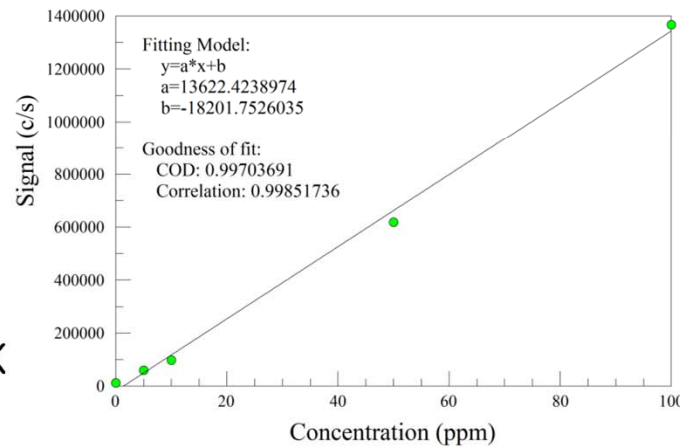

V51 Signal vs. Spot Size

Signal vs Spot Size 200 K

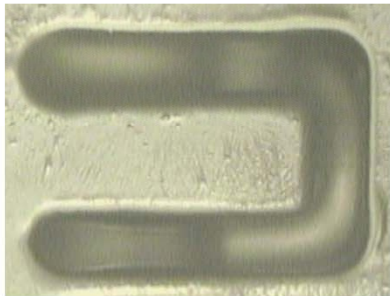
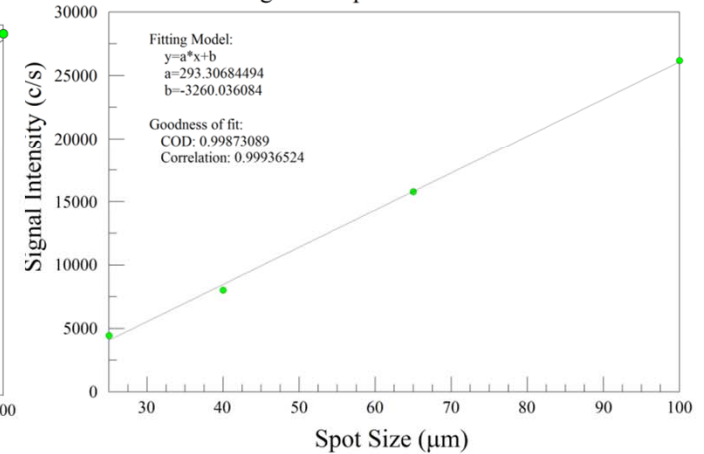

Post-Ablation Oil at 200 K

- Collaboration with Dr. Aaron Roberts (UNT Biology Department)
- Individual Hg202 spectrum for each raster pattern.
- 2D Image created using the Hg202 signal and the X and Y coordinates of the ablated area.

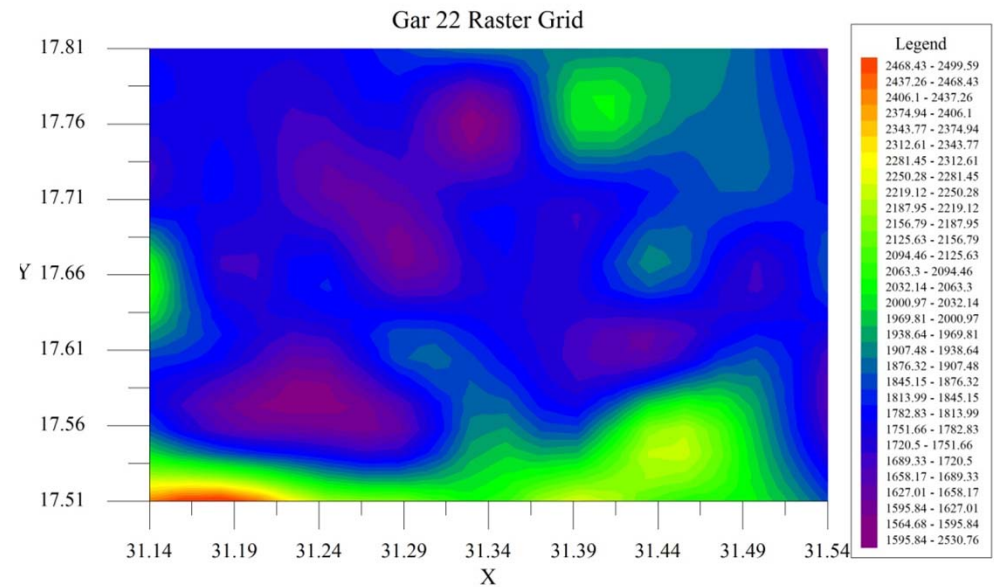
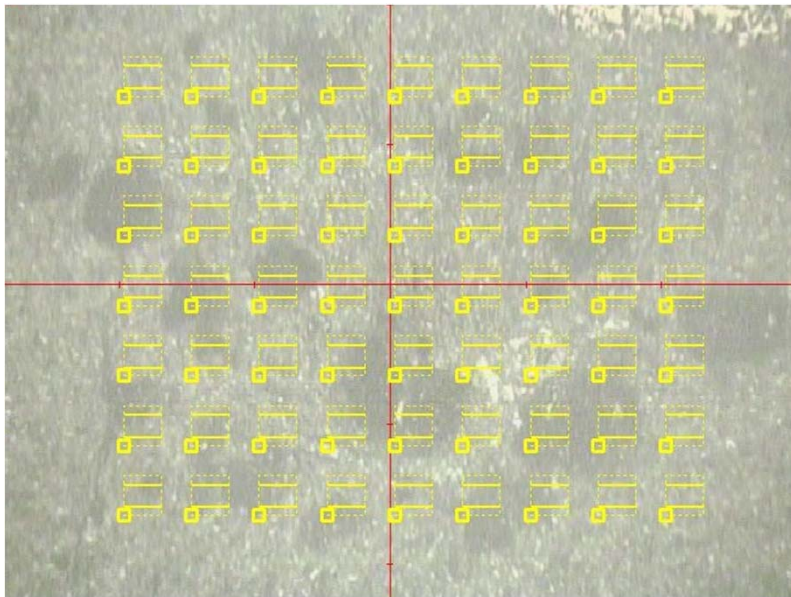
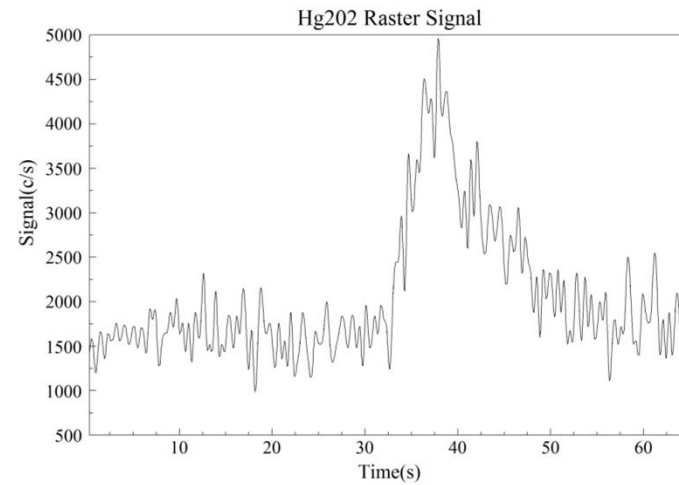

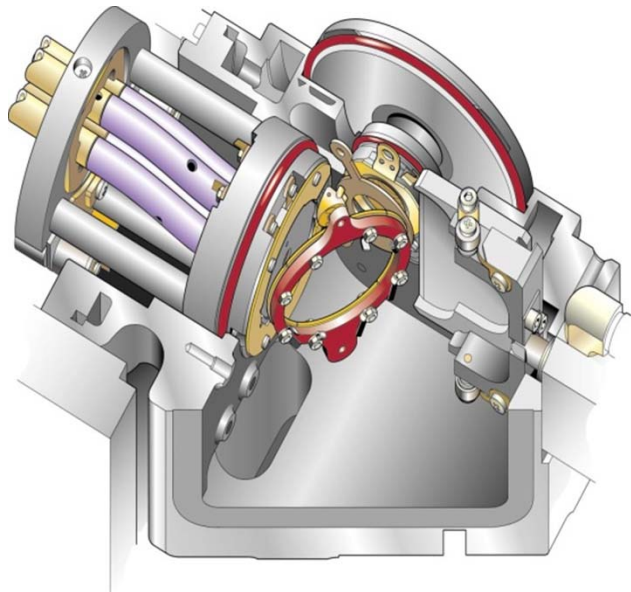

Bruker (Formerly Varian)  
820 ICP-MS Ion Optics

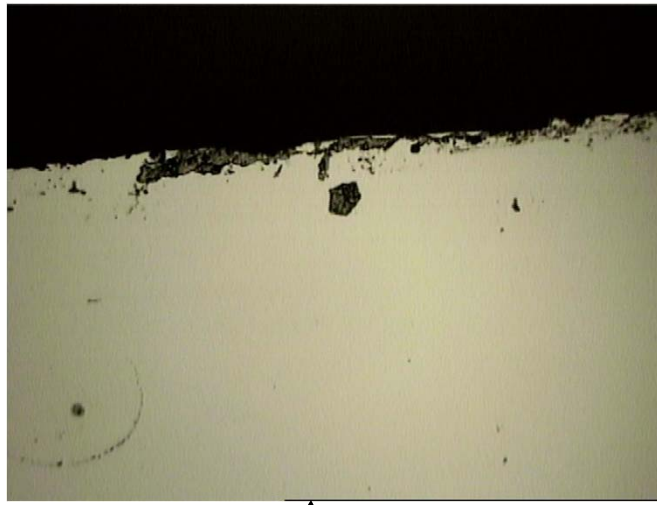

Soft Landed Hf on Si

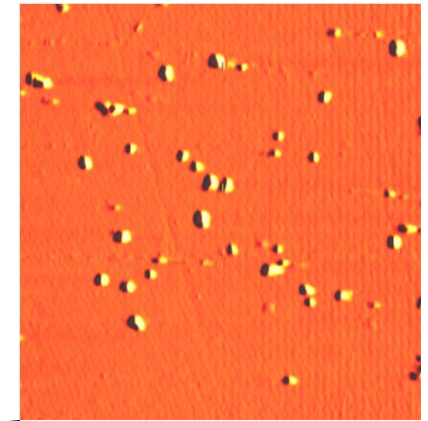

SEM Image of  
ablation track

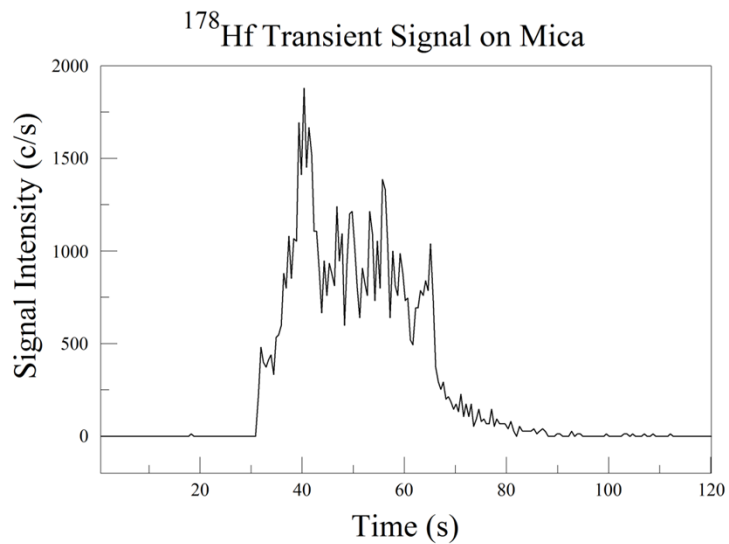
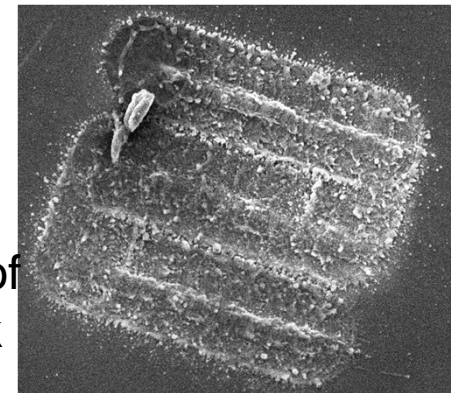

$^{178}\text{Hf}$  LA-ICP-MS  
transient signals  
showing spatially  
resolved Hf on  
surface (left) and  
in defects (right)

