

FINAL REPORT

Demonstration of Advanced Oxidation Treatment
of Shipboard Blackwater and Graywater

ESTCP Project WP-200802

December 2010

Tina Lerke
Sheila Riggs
Naval Surface Warfare Center, Carderock Division

Howard Castle
Naval Sea Systems Command

This document has been cleared for public release



REPORT DOCUMENTATION PAGE*Form Approved
OMB No. 0704-0188*

The public reporting burden for this collection of information is estimated to average 1 hour per response, including the time for reviewing instructions, searching existing data sources, gathering and maintaining the data needed, and completing and reviewing the collection of information. Send comments regarding this burden estimate or any other aspect of this collection of information, including suggestions for reducing the burden, to the Department of Defense, Executive Services and Communications Directorate (0704-0188). Respondents should be aware that notwithstanding any other provision of law, no person shall be subject to any penalty for failing to comply with a collection of information if it does not display a currently valid OMB control number.

PLEASE DO NOT RETURN YOUR FORM TO THE ABOVE ORGANIZATION.

1. REPORT DATE (DD-MM-YYYY)		2. REPORT TYPE		3. DATES COVERED (From - To)	
4. TITLE AND SUBTITLE				5a. CONTRACT NUMBER	
				5b. GRANT NUMBER	
				5c. PROGRAM ELEMENT NUMBER	
6. AUTHOR(S)				5d. PROJECT NUMBER	
				5e. TASK NUMBER	
				5f. WORK UNIT NUMBER	
7. PERFORMING ORGANIZATION NAME(S) AND ADDRESS(ES)				8. PERFORMING ORGANIZATION REPORT NUMBER	
9. SPONSORING/MONITORING AGENCY NAME(S) AND ADDRESS(ES)				10. SPONSOR/MONITOR'S ACRONYM(S)	
				11. SPONSOR/MONITOR'S REPORT NUMBER(S)	
12. DISTRIBUTION/AVAILABILITY STATEMENT					
13. SUPPLEMENTARY NOTES					
14. ABSTRACT					
15. SUBJECT TERMS					
16. SECURITY CLASSIFICATION OF:			17. LIMITATION OF ABSTRACT	18. NUMBER OF PAGES	19a. NAME OF RESPONSIBLE PERSON
a. REPORT	b. ABSTRACT	c. THIS PAGE			19b. TELEPHONE NUMBER (Include area code)

Table of Contents

	<u>Page</u>
List of Acronyms and Symbols	v
Acknowledgments.....	vii
 Executive Summary	 1
1.0 Introduction.....	4
1.1 Background.....	4
1.2 Objective of the Demonstration	4
1.3 Regulatory Drivers.....	5
2.0 Demonstration Technology.....	6
2.1 Technology Description.....	6
2.2 Technology Development.....	15
2.3 Advantages and Limitations of the Technology	16
3.0 Performance Objectives	18
3.1 Performance Objective: Meet Effluent Quality Standards	19
3.2 Performance Objective: Meet Minimum Startup Time	19
3.3 Performance Objective: Meet Treatment Capacity.....	20
3.4 Performance Objective: Demonstrate Level of Operator Involvement	20
3.5 Performance Objective: Demonstrate System Reliability	21
4.0 Site/Platform Description.....	22
4.1 Test Platforms/Facilities	22
4.2 Present Operations	23
4.3 Site-Related Permits and Regulations.....	23
5.0 Test Design	25
5.1 Shock Risk Analysis	25
5.2 Laboratory Demonstration	26
5.2.1 Test Influent	27
5.2.2 Phase 1 Testing	28
5.2.2.1 Examinations.....	28
5.2.2.2 Analyses	29
5.2.2.3 Pre-Operational Tests.....	30
5.2.2.4 Operational Tests	32
5.2.3 Phase 2 Testing	34
5.2.3.1 Examinations.....	34
5.2.3.2 Analyses	34
5.2.3.3 Pre-Operational Tests.....	34
5.2.3.4 Operational Tests	35

Table of Contents

	<u>Page</u>
5.2.4 Measurement/Monitoring Plan	36
5.2.4.1 Standard Test Methods	36
5.2.4.2 Sampling Plan	38
5.2.4.3 Laboratory Measurement Equipment	39
6.0 Performance Assessment	40
6.1 Shock Risk Analysis	40
6.1.1 Modules Analyzed	40
6.1.2 Other Equipment	43
6.2 Laboratory Demonstration	45
6.2.1 System Installation	45
6.2.2 Test Preparation	46
6.2.2.1 Commissioning of the System	46
6.2.2.2 Laboratory Checkout	46
6.2.3 Phase 1 Test Results	50
6.2.3.1 Examinations	50
6.2.3.2 Analyses	51
6.2.3.3 Pre-Operational Tests	52
6.2.3.4 Operational Tests	53
6.2.4 Phase 2 Test Results	65
6.2.4.1 Operational Tests	65
7.0 Cost Assessment	77
7.1 Cost Model	77
7.2 Cost Analysis and Comparison	78
7.2.1 Direct Costs – Start-up	79
7.2.2 Direct Costs – Operation and Maintenance	79
7.2.3 Indirect Costs	82
7.2.4 Life Cycle Cost	83
8.0 Implementation Issues	84
8.1 Stakeholders and Implementation	84
8.2 Transition Impacts	84
8.3 Technology Transfer Plans	85
9.0 References	86

Table of Contents

	<u>Page</u>
Appendix A: Points of Contact.....	A-1
Appendix B: NSWCCD Code 669 DDAM Unclassified Coefficient Memorandum.....	B-1
Appendix C: Detailed Test Requirements	C-1
Appendix D: NSWCCD Code 669 DDAM Analysis Review Memorandum	D-1
Appendix E: Navalix Shock Analysis Report	E-1
Appendix F: Installation/Commissioning Details.....	F-1
Appendix G: Operation, Maintenance and Installation Manual	G-1
Appendix H: Environmental Safety Health Review	H-1
Appendix I: Maintenance Log, Daily Flow and Analytical Data for Phase 1	I-1
Appendix J: Statistical Analysis Technical Note No. 10-167-01 for Phase 1	J-1
Appendix K: Maintenance Log, Daily Flow and Analytical Data for Phase 2.....	K-1
Appendix L: Statistical Analysis Technical Note No. 10-167-02 for Phase 2	L-1
Appendix M: Cost Analysis Data	M-1

List of Figures

	<u>Page</u>
Figure 1. Navalix Orion™ System Process Flow Diagram	7
Figure 2. Sludge Reduction and Management System Process Flow Diagram.....	8
Figure 3. Navalix Orion™ Advanced Oxidation Wastewater Treatment System	9
Figure 4. Photo of Navalix Orion™ Advanced Oxidation Wastewater Treatment System Laboratory Installation.....	10
Figure 5. Aerial Isometric View of the Navalix Orion Advanced Oxidation Orion™ Advanced Oxidation Wastewater Treatment System	11
Figure 6. Photos of Covered Shaker Screen with Top Cover and Screen	11
Figure 7. Photo of Flocculator and Hydraulic Separator	12
Figure 8. Photos of Tubular Filter Skid and Membrane Filtrr Skid.....	13
Figure 9. Photos of Advanced Oxidation Stirred Reactor (AOSR) and Ultraviolet Unit.....	13
Figure 10. Photos of Twin Engineering Desiccant Air Dryer and Ozone Generator	14
Figure 11. Photos of Navalix Advanced Oxidation Technology Applications	15
Figure 12. Photos of NSWCCD Non-Oily Wastewater Laboratory Setup for Pilot and Full-Scale Tests.....	22
Figure 13. Photo of the Navalix Orion™ Advanced Oxidation Wastewater Treatment System Rear View	45
Figure 14. Photos of the Clogged 200-Mesh Screen and the Cleaned 200-Mesh Screen	47
Figure 15. Photos of Samples Collected During Checkout	49
Figure 16. Graph of Analytical Results for BOD ₅ for Phase 1	58
Figure 17. Graph of Analytical Results for COD for Phase 1	59
Figure 18. Graph of Analytical Results for TSS for Phase 1	60
Figure 19. Graph of Analytical Results for FC for Phase 1	61
Figure 20. Graph of Analytical Results for O/G for Phase 1	62

List of Figures

	<u>Page</u>
Figure 21. Graph of Analytical Results for BOD ₅ for Phase 2.....	69
Figure 22. Graph of Analytical Results for COD for Phase 2	70
Figure 23. Graph of Analytical Results for TSS for Phase 2.....	71
Figure 24. Graph of Analytical Results for FC for Phase 2.....	72
Figure 25. Analytical Results for O/G for Phase 2	73
Figure 26. Graph of Energy Usage versus Effluent Processed.....	80

List of Tables

	<u>Page</u>
Table 1. Navalis Advanced Oxidation Technology Applications	14
Table 2. Navalis Orion TM and Poseidon® Analytical Data	16
Table 3. Performance Objectives.....	18
Table 4. Shipboard Wastewater Organic Loading Rates	27
Table 5. Analytical Methods.....	36
Table 6. Sample Schedule for the Laboratory Demonstration (Phase 1 and 2).....	38
Table 7. Analytical Results for Checkout.....	49
Table 8. Navalis Orion TM Tank Size and Capacity.....	50
Table 9. Phase 1 Examinations Summary.....	51
Table 10. Phase 1 Analysis Summary.....	52
Table 11. Phase 1 Pre-operational Tests.....	53
Table 12. Phase 1 Operational Tests.....	54
Table 13. Phase 1 BW/GW Cold Start Analytical Results	55
Table 14. Phase 1 BW/GW Processing Summary for 15 May – 23 June 2009.....	55
Table 15. Phase 1 Influent Composition.....	56
Table 16. Phase 1 Sampling Results	57
Table 17. Phase 2 BW Cold Start Analytical Results.....	66
Table 18. Phase 2 BW Processing Summary for 24 March – 28 April 2010	67
Table 19. Phase 2 Influent Composition.....	68
Table 20. Phase 2 Sampling Results	69
Table 21. Performance Objectives Results	76
Table 22. Navalis Orion TM Cost Factors.....	77
Table 23. Navalis Orion TM Life Cycle Cost Estimate by NSWCCD	83

List of Acronyms and Symbols

A ₀	Operational Availability
ADEC	Alaska Department of Environmental Conservation
AET	Aerated Equalization Tank
AOSR	Advanced Oxidation Stirred Reactor
ASTM	American Society for Testing and Materials
BD	Below Detection
BOD ₅	Five-Day Biochemical Oxygen Demand
BW	Blackwater
CFR	Code of Federal Regulations
cfu	Colony-Forming Units
CHT	Collection, Holding and Transfer
COD	Chemical Oxygen Demand
DCMR	District of Columbia Municipal Regulations
DDAM	Dynamic Design Analysis Method
Dia	Diameter
DoD	Department of Defense
ESH	Environmental Safety and Health
ESTCP WP	Environmental Security Technology Certification Program, Weapons Systems and Platforms
FC	Fecal Coliform
gpd	Gallons Per Day
gpm	Gallons Per Minute
GW	Graywater
H	Height
HASP	Health and Safety Plan
HP	Horsepower
ILS	Integrated Logistics Support
IMO	International Maritime Organization
lbs	pounds
LCC	Life Cycle Costs
L	Length
LWFS	Liquid Waste Feed System
m ³	Cubic meters
MARPOL 73/78	International Convention for the Prevention of Pollution from Ships, 1973, as modified by the Protocol of 1978
MaxTTR	Maximum Time To Repair
MEPC	Marine Environmental Protection Committee
mg/L	Milligrams per liter
MIL-PRF	Military Performance Specification
MIL-S	Military Standard
MIL-STD	Military Standard
min	Minute
MPN	Most Probable Number

List of Acronyms and Symbols

MSD	Marine Sanitation Device
MTBCF	Mean Time Between Critical Failure
MTTR	Mean Time To Repair
NAVFAC	Naval Facilities Engineering Command
NAVSEA	Naval Sea Systems Command
ND	Not Detected
NEMA	National Electrical Manufacturers Association
NSWCCD	Naval Surface Warfare Center, Carderock Division
O/G	Oil and Greases
OPNAVINST	Office of the Chief of Naval Operations Instruction
ORP	Oxidation-Reduction Potential
OSHA	Occupational Safety and health Administration
PLC	Programmable Logic Controller
PMS	Preventative Maintenance Schedule
PPE	Personal Protective Equipment
P&ID	Piping and Instrumentation Diagram
SDT	Sludge Decant and Transfer
SEA 05P25	Naval Sea Systems Command, Code 05P25
SHIPMAIN	NAVSEA Ship Maintenance
SRT	Sludge Reduction Tank
TIAP	Technology Identification and Assessment Program
TSS	Total Suspended Solids
TWH	Technical Warrant Holder
UNDS	Uniform National Discharge Standards
USC	United States Code
USCG	United States Coast Guard
UV	Ultraviolet
V	Volts
VAC	Volts A/C
VCHT	Vacuum, Collection, Holding and Transfer
W	Width
“	Inches
‘	Feet
°C	Degrees Celsius
°F	Degrees Fahrenheit
λ	Wavelength

Acknowledgments

The laboratory evaluation was sponsored by the Environmental Security Technology Certification Program (ESTCP) Weapons Systems and Platforms (WP) and Naval Sea Systems Command (NAVSEA). The ESTCP WP program manager is Mr. Bruce Sartwell. The NAVSEA Shipboard Environmental Protection branch head and program manager is Mr. Michael Chapkovich (SEA 05P25). The NAVSEA Technical Warrant Holder for Environmental Protection Systems is Mr. Peter McGraw (SEA 05P25). Naval Environmental Systems contributed labor hours to support laboratory testing. The work was performed by Naval Surface Warfare Center, Carderock Division (NSWCCD), Wastewater Management Branch (Code 633). The project team was Ms. Tina Lerke (Lead Investigator), Ms. Sheila Riggs, Mr. Dennis Buckley, Mr. Thomas O'Connell, and Mr. Howard Castle from NSWCCD, and Mr. Stephen Markle, P.E., and Mr. Jack McCrea, P.E. from Naval Environmental Systems.

Executive Summary

A demonstration project was conducted to evaluate a shipboard wastewater treatment system that could potentially meet the restrictive requirements of Department of Defense (DoD) vessel design and operation and meet current and future effluent discharge standards.

Commercial systems are available, but are challenged by the high strength wastewater, the need for fast startup in meeting effluent quality standards quickly, and the lack of highly trained operators dedicated to a treatment system. All these factors, as well as size and weight restrictions, create barriers for seamless integration of commercial systems. Shipboard treatment versus the use of a holding tank will allow more mission flexibility, reduce or eliminate disposal costs, and reduce security risks in foreign ports.

The Navalis Orion™ Advanced Oxidation Wastewater Treatment System employs advanced oxidation as its primary process technology. The overall objective was to demonstrate that advanced oxidation technology is applicable to DoD vessel wastewater, and to evaluate the system installation and operation in a realistic shipboard environment. The criteria include treatment capacity, reduction of key effluent quality parameters to meet the environmental regulations, startup time and the absence of critical component failures.

The system is designed for a maximum flow rate of 5 gallons per minute or 7200 gallons per day (gpd). The manufacturer information is based on testing with nominal influent of 500 milligrams per liter (mg/L) five-day Biochemical Oxygen Demand (BOD₅) and 1500 mg/L Total Suspended Solids (TSS). The manufacturer designed the system to treat a combination of shipboard generated wastewater (vacuum-collected blackwater combined with gravity-collected graywater) produced by approximately 150 people.

The Navalis Orion™ system was purchased for full-scale evaluation and installed at the Non-Oily Wastewater Laboratory, a liquid waste laboratory facility at Naval Surface Warfare Center, Carderock Division (NSWCCD) in West Bethesda, Maryland. The laboratory evaluation consisted of two phases. Phase 1 evaluated the treatment system performance while processing combined blackwater and graywater. Phase 2 evaluated the treatment system performance while processing blackwater alone. The full-scale laboratory test followed the inspections and system checks listed in the military performance specification, MIL-PRF-30099.

In Phase 1 testing, the Navalis Orion™ system processed combined blackwater and graywater. The effluent BOD₅ and Chemical Oxygen Demand (COD) values were consistently higher than the desired standards, while both effluent TSS and Fecal Coliform (FC) thresholds were met. Even with very effective solids removal, the effluent BOD₅ and COD levels remained high. The high BOD₅ and COD values are an indication that the advanced oxidation step did not oxidize the organic contents sufficiently. The fact that TSS levels were very low in the effluent shows that precipitated solids were not the source of organics. The system averaged 22 hours of daily operation throughout the Phase 1 evaluation. The daily average capacity of the system was 4023 gpd, which was not as high as estimated at 6600 gpd. The average and maximum processing rates of 6600 gpd and 7200 gpd were not attained. A large impairment of the system operation was due to the Solids Separation Zone.

The purpose of the evaluation was not to perform a detailed analysis of each unit operation in the system, but to test a commercial system as a whole in automatic mode with little operator interaction. However, with the unexpected performance in Phase 1 and issues with individual components, some modifications were made to the system to improve performance for Phase 2.

With BOD₅ and COD values remaining high after the advanced oxidation step, the ozone levels in the reactor were suspect. To improve the efficiency of the ozone generator, an air dryer was installed to provide oil-free, dry compressed air. In order to improve dissolved ozone levels in the reactor, a higher capacity ozone dissolving pump was installed for the reactor recirculation and ozone additions for Phase 2 testing. To improve processing capacity and reduce sludge generation, the backwash source was changed from the Finishing Tank to the membrane permeate. Different sizes of Shaker Screen and bag filter media were tested.

In Phase 2 testing, the Navalys Orion™ system processed blackwater alone. All effluent quality parameter thresholds were met. The Ultraviolet (UV) unit experienced issues, and shutdown for days. The system averaged 24 hours of daily operation throughout the Phase 2 evaluation. The daily average capacity of the system was 1500 gpd, which was not as high as estimated at 6600 gpd. The average and maximum processing rates of 6600 gpd and 7200 gpd were not attained. The capacity of the system processing blackwater was much lower than estimated. The same reasons from Phase 1 can be cited for reduced throughput. In addition, the flocculent was not optimal for a blackwater influent leading to more solids removed by the bag filters and increased backwash frequency. Sludge generation was also greater than expected at an average of 297 gpd. The system generated 23% of the processed volume as sludge, which was higher than estimated by the manufacturer. The excessive sludge generation caused the system to slow down the processing rate due to lack of influent.

The Navalys Orion™ system did not meet the minimum startup time in either test phase, since the capacity was not met.

In both phases, the system required operator involvement to operate and maintain the system for several hours per day. The details of daily operation and troubleshooting were documented in the laboratory logbook. Each installation will need to judge whether or not the documented labor level is acceptable based on labor force available and mission.

No critical components failed in Phase 1, meeting the max time-to-repair requirement. Although it did not affect the effluent performance of Phase 2, the UV unit experienced inconsistent operation for days which exceeded the max time-to-repair requirement.

Overall, the evaluation has demonstrated that advanced oxidation using ozone and ultraviolet light is a potential technology for the treatment of blackwater and graywater generated on a military vessel and warrants further testing. The objective was to evaluate advanced oxidation technology. The Navalys Orion™ Model 5 Advanced Oxidation Wastewater Treatment System is one of the commercial wastewater treatment systems available. To help improve the system performance and correct issues, optimization is needed.

A formal cost/benefit analysis could not be performed. Comparing the cost of purchasing, installing and operating a holding tank cannot be compared to the same costs for a treatment system. The treatment system is an additional capability with higher associated costs. The Life Cycle Cost (LCC) estimated by Navalis Environmental Systems was evaluated and a new LCC was estimated based on experience during the laboratory testing and shipboard estimates. The new LCC was calculated to be more than two times greater than the Navalis estimate primarily due to the higher labor requirements for operation, maintenance and repair of the complex system.

1.0 Introduction

1.1 Background

Currently, holding tanks are used onboard ships to contain blackwater until the vessel is located outside regulated waters for allowable discharge, or until the blackwater can be transferred to an in-port facility or barge. Now, with impending changes in regulations, the traditional holding capacity may no longer be adequate. The lack of capacity will likely restrict operations of Department of Defense (DoD) vessels in littoral waters.

Commercial systems are available, but are challenged by the high strength wastewater, the need for fast startup in meeting effluent quality standards quickly, and the lack of highly trained operators dedicated to a treatment system. All these factors, as well as size and weight restrictions, create barriers for seamless integration of commercial systems. Shipboard treatment versus the use of a holding tank will allow more mission flexibility, reduce or eliminate disposal costs, and reduce security risks in foreign ports.

The Navalis Orion™ Advanced Oxidation Wastewater Treatment System employs advanced oxidation as its primary process technology. Ozone is used to oxidize dissolved organic and inorganic material following solids removal and ultrafiltration. The advanced oxidation reaction occurs when residual ozone in water from the batch reactor is exposed to polychromatic ultraviolet (UV) light, creating short-lived species of higher oxidation potential such as hydrogen peroxide and the hydroxyl radical.

Navalis blackwater (BW) and graywater (GW) treatment systems are successfully used in land-based installations. The systems show promise for shipboard use due to their compact and modular design, and rapid startup capability. Effluent quality standards can be met in hours versus days, giving vessels the flexibility of leaving port with short notice. Biological systems require days or weeks to build a viable biomass to treat BW and GW successfully. The Navalis Orion™ system offers a compact, modular system design with rapid startup capability and minimal operator involvement, while meeting effluent quality standards.

1.2 Objective of the Demonstration

The overall objective is to demonstrate that advanced oxidation technology is applicable to DoD vessel wastewater, and to evaluate the system installation and operation in a realistic shipboard environment. The following are the specific technical objectives of this project:

- Demonstrate the performance of an advanced oxidation treatment system to process shipboard generated BW and GW with measurement of key effluent quality parameters.
- Demonstrate the fast startup time of an advanced oxidation treatment system with measurement of the minimum time period required to attain effluent quality goals.
- Demonstrate the level of operator involvement with documentation of time required for routine operation and maintenance.
- Demonstrate reliability of equipment with documentation of equipment deficiencies and failures.

1.3 Regulatory Drivers

The need for shipboard wastewater treatment for military vessels is driven by existing and anticipated future regulations. Without treatment, military operations in littoral waters could be restricted by the limited holding volume of the ship. The Clean Water Act of 1977 prohibits the discharge of untreated sewage in restricted waters from military or commercial vessels as outlined in the Federal Water Pollution Control Act (33USC1322).[1] International regulations also restrict discharge of untreated sewage, as outlined in Annex IV of the International Convention for the Prevention of Pollution from Ships, referred to as MARPOL 73/78.[2]

Navy policy is outlined in the Office of the Chief of Naval Operations Instruction 5090.1C (OPNAVINST 5090.1C).[3] However, changing military missions along with increasing disposal costs and more stringent regulations have led to more focus on BW treatment marine sanitation devices (MSDs).

2.0 Demonstration Technology

2.1 Technology Description

The Navalis Orion™ system employs advanced oxidation as the primary technology used in its process. Ozone is used to oxidize dissolved organic and inorganic material following solids removal and ultrafiltration. Ozone is an allotrope of oxygen that is 1.5 times as dense as oxygen, 12.5 times more soluble in water, and leaves no residuals or byproducts, except oxygen and a minimal amount of carbon dioxide and water. It is an unstable, non-flammable oxidizer that must be generated on-site. Its oxidation potential, measured in volts (V) of electrical energy, indicates its ability to oxidize organic and inorganic material. The oxidation potential of ozone (-2.07 V) is greater than that of hypochlorite acid (-1.49V) and chlorine (-1.36V), both of which are commonly used in wastewater treatment. Ozone is considered to decompose in water as follows [4]:

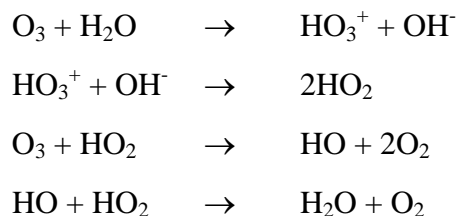

Exposure of ozonated water to UV light (λ) accelerates the formation of the hydroxyl radical (OH \cdot) in the following series of reactions:

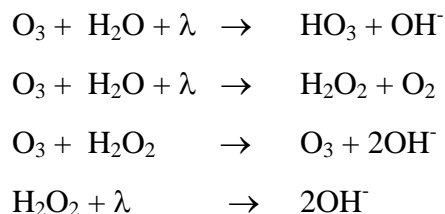

The free radicals HO $_2$ and OH \cdot react with a variety of impurities such as metal salts, organic matter, including microorganisms, hydrogen and hydroxide ions. The free radicals are more potent germicides than hypochlorite acid by factors of 10 to 100 and disinfect 3,125 times faster than chlorine. The advanced oxidation reaction occurs when residual ozone in water from the batch reactor is exposed to polychromatic UV light, creating short-lived species of higher oxidation potential such as hydrogen peroxide and the hydroxyl radical. The combination of ozone, UV and advanced oxidation is ideal for destruction of organic material through breaking of the carbon-carbon bond.[5]

The system is comprised of three principal processes:

- Solids separation via Covered Shaker Screen, Hydraulic Separator and Sludge Reduction Tank
- Filtration and ultrafiltration via tubular backwashable filters and tubular ceramic ultrafilters

- Advanced oxidation through permeate reaction in a stirred reactor using ozone and medium pressure, high intensity polychromatic UV light.

Figure 1 is the process flow diagram and illustrates the process in more detail. The diagram includes the grouping of system components into the three process zones.

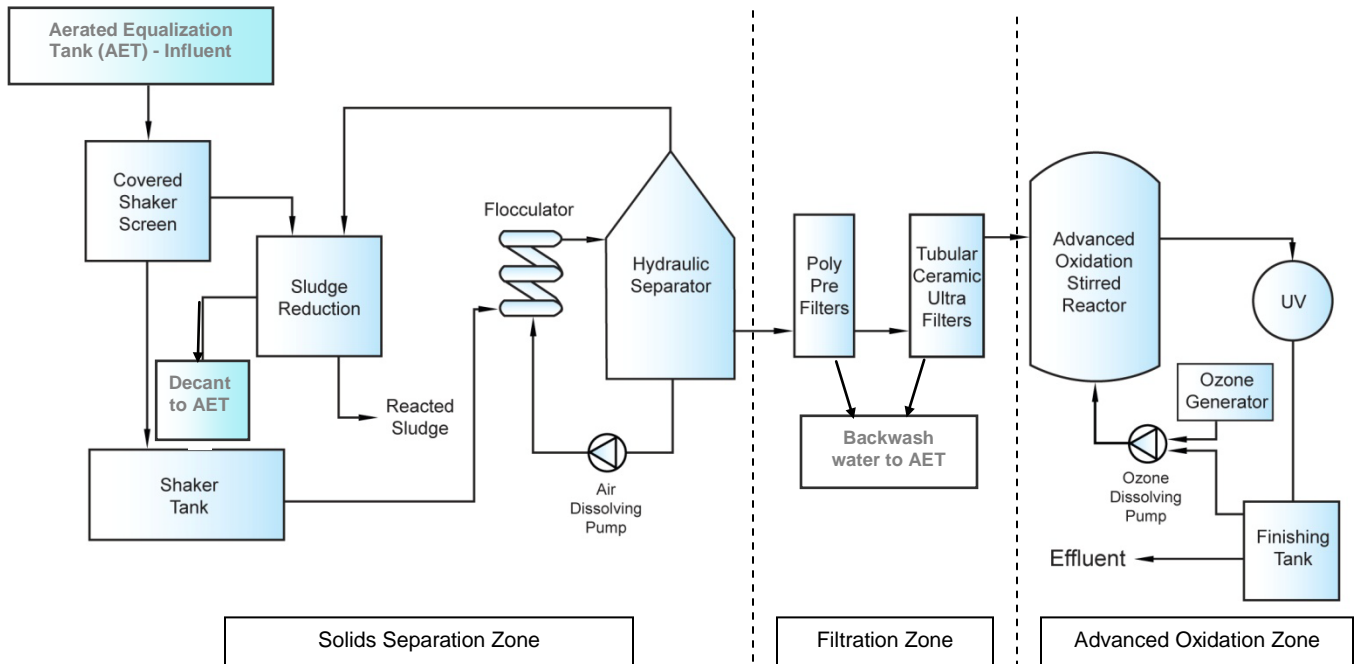

Figure 1. Navalis Orion™ System Process Flow Diagram

An Aerated Equalization Tank (AET) is required to collect the wastewater allowing both hydraulic and chemical equalization of the wastewater streams. The AET is external to the Navalis Orion™ system. Wastewater from the aerated equalization tank is introduced into the system through the Covered Shaker Screen. Solids fall by gravity into the Navalis Nautilus™ Sludge Reduction System.

Screened wastewater from the Covered Shaker Screen is fed through the Flocculator where air and a solution of poly aluminum chlorohydrate are added to assist in flocculation and flotation of solids. Batch clarification occurs in the Hydraulic Separator, a stainless steel hydraulic lift dissolved air flotation device designed to provide a specific hydraulic retention time. As wastewater enters the Hydraulic Separator, the dissolved air forms very small bubbles (10 to 20 microns) that affix to the pin floc formed in the Flocculator, and then float the solids to the surface. Continual addition of aerated water into the Hydraulic Separator maintains a floating solids blanket. At periodic intervals, the floating solids blanket is transferred to the Sludge Reduction System. The phase separation is a time-based action with the pump programmed to transfer for a set period of time.

The clarified liquor is pumped from the Hydraulic Separator to the Advanced Oxidation Stirred Reactor (AOSR) through two poly tubular backwashable membranes and a single 20-nanometer

ultrafiltration tubular membrane module. The permeate is transferred to the AOSR, and the retentate is directed back to the Aerated Equalization Tank. Three filter and membrane automatic wash and recovery modes are provided and controlled by the programmable logic controller.

The AOSR is a stirred, media-packed, stainless steel vessel designed to provide a specific residence time. The AOSR is coupled with an ozone dissolving pump and a UV light disinfection unit. The reactor contains neutrally buoyant media, which provide surface area for the interaction and oxidation of dissolved ozone and organic material. During the cycle, water is continuously recirculated between the reactor and the UV unit. Ozone is added at the bottom of the reactor vessel. The ozonated water is next passed through a UV disinfection unit. The advanced oxidation reaction occurs in the UV light disinfection unit. A medium pressure, high intensity unit produces polychromatic light, which transforms any residual ozone into a fast-reacting species, such as hydrogen peroxide and hydroxyl radicals, to destroy any residual organic material. A single ozone generator produces all the ozone required by the system split 80% to the AOSR and 20% to the Sludge Reduction Tank.

Filtered water from the membranes is fed to the AOSR and then enters the Finishing Tank. Additional ozone is dissolved into a pressurized stream of Finishing Tank water which passes through the UV unit and then recirculated to the AOSR. Water in the Finishing Tank is recirculated to the UV unit and AOSR until the level in the Finishing Tank reaches a predetermined level. Treated water is then discharged.

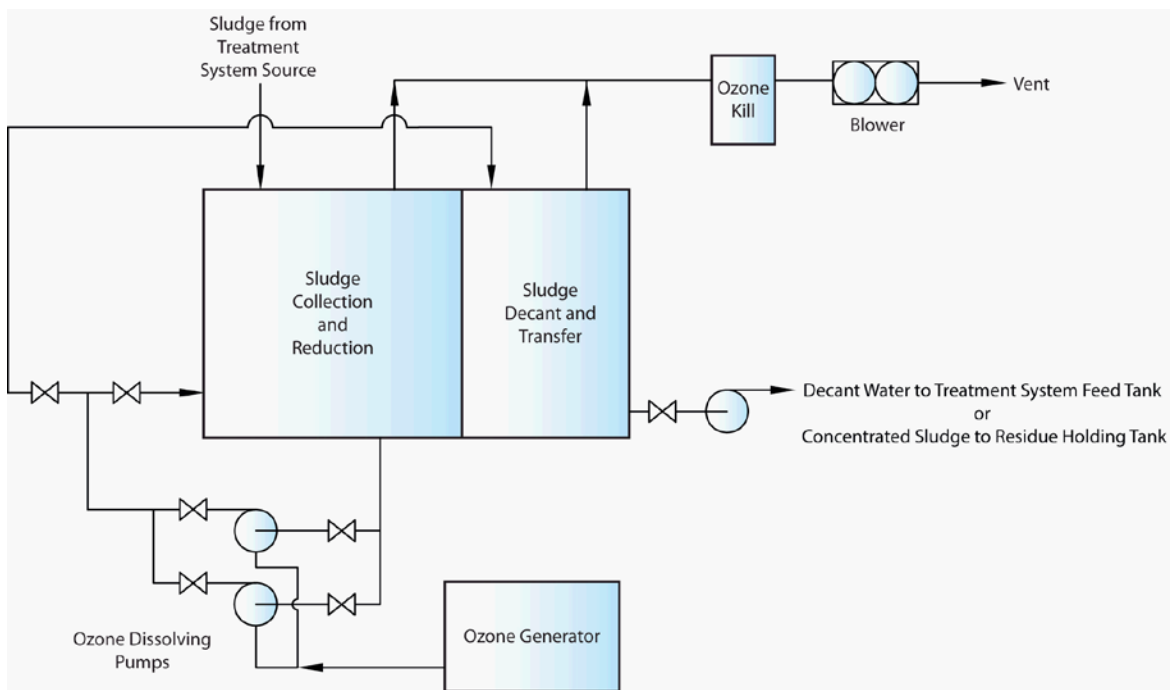

Figure 2. Sludge Reduction and Management System Process Flow Diagram

The Sludge Reduction and Management System, shown in Figure 2, is comprised of two vessels, the Sludge Reduction Tank (SRT), and the Sludge Decant and Transfer (SDT) Tank. The SRT

contains a sludge recirculation and ozonation loop and level controls. Solids from the Hydraulic Separator and membrane retentate are reacted with highly ozonated recirculation water to oxidize organic material, reducing its volume. The ozone for the SRT is provided by the same ozone generator that feeds the finishing tank water. Periodically, this water is pumped to the quiescent Sludge Decant and Transfer Tank where material will stratify by gravity. At specified intervals, clarified water is pumped back to the Aerated Equalization Tank, and remaining solids removed to the separate sludge storage tank. The phase separation is a time-based action with the pump programmed to transfer for a set period of time.

As a safety precaution, the system tanks are maintained under a slight negative pressure to prevent ozone and process gases from exiting into the laboratory space in the event of a leak. The vent system blower pulls system gases through a heated catalytic converter gas destruction system that converts ozone to oxygen.

The system is designed for a maximum flow rate of 5 gallons per minute (gpm) or 7200 gallons per day (gpd) when operating 24 hours per day. The manufacturer information is based on testing with nominal influent of 500 mg/L Biochemical Oxygen Demand (BOD₅), 1500 mg/L Total Suspended Solids (TSS), and a generation rate of 65 gallons/person/day. The manufacturer designed the system to treat a combination of shipboard generated blackwater and graywater. Based on the shipboard wastewater generation values provided in the Navy Performance Specification for Treatment of Blackwater and Combined Blackwater and Graywater, MIL-PRF-30099, the Navalis Orion™ system can accommodate the wastewater (vacuum-collected blackwater combined with gravity-collected graywater) produced by approximately 150 people.[6] The isometric views of the Navalis Orion™ system are shown in Figure 3. A portion of the piping and valves were omitted for a better view of the system components. A photo of the installed system is shown in Figure 4.

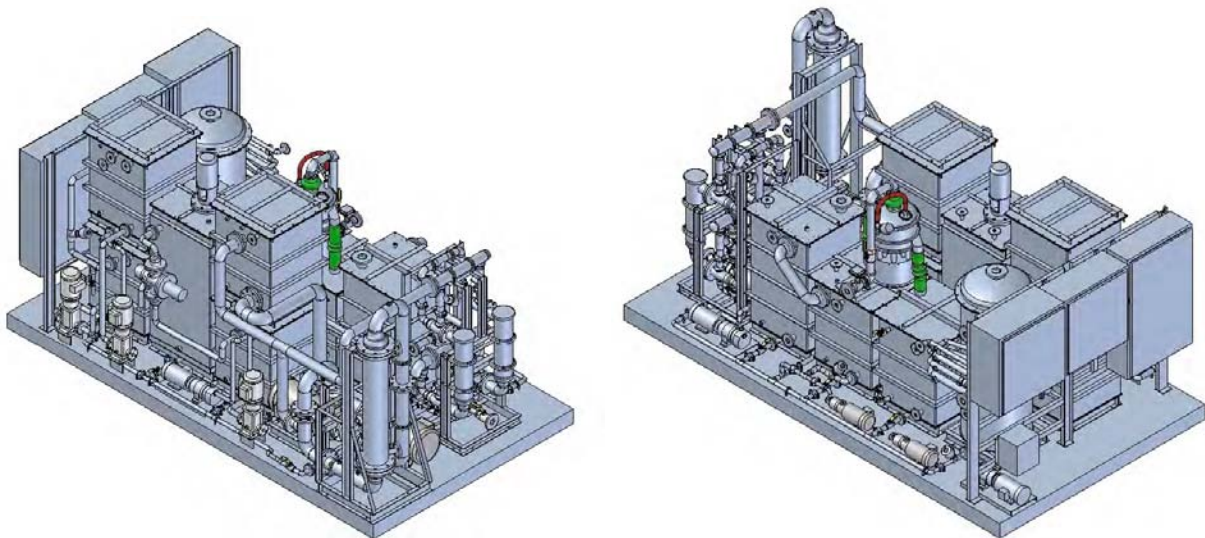

Figure 3. Navalis Orion™ Advanced Oxidation Wastewater Treatment System
Right Front Isometric View and Left Rear Isometric View



Figure 4. Photo of Navalis Orion™ Advanced Oxidation Wastewater Treatment System Laboratory Installation

Navalis adheres to an ease-of-installation and maintenance philosophy. Navalis Orion™ components are configured on a skid mount system comprised of 28-inch galvanized steel squares which afford ease of installation on ship foundations and make a variety of configurations possible, from a very compact square to open linear for optimal use of space. Each modular component fits through a 28-inch square opening to ease rigging to the designated system compartment. This enables installation with minimal, if any, modifications to existing ship structure. Further, the arrangement enables easy access to areas requiring routine maintenance. Inlet and discharge piping is 2 inches in diameter, with either flanged or sanitary fittings ensuring compatibility with existing and planned collection and discharge piping. Figure 5 is an aerial view of the Navalis Orion™ system with indication of each major component as received in the laboratory. Each component is described below:

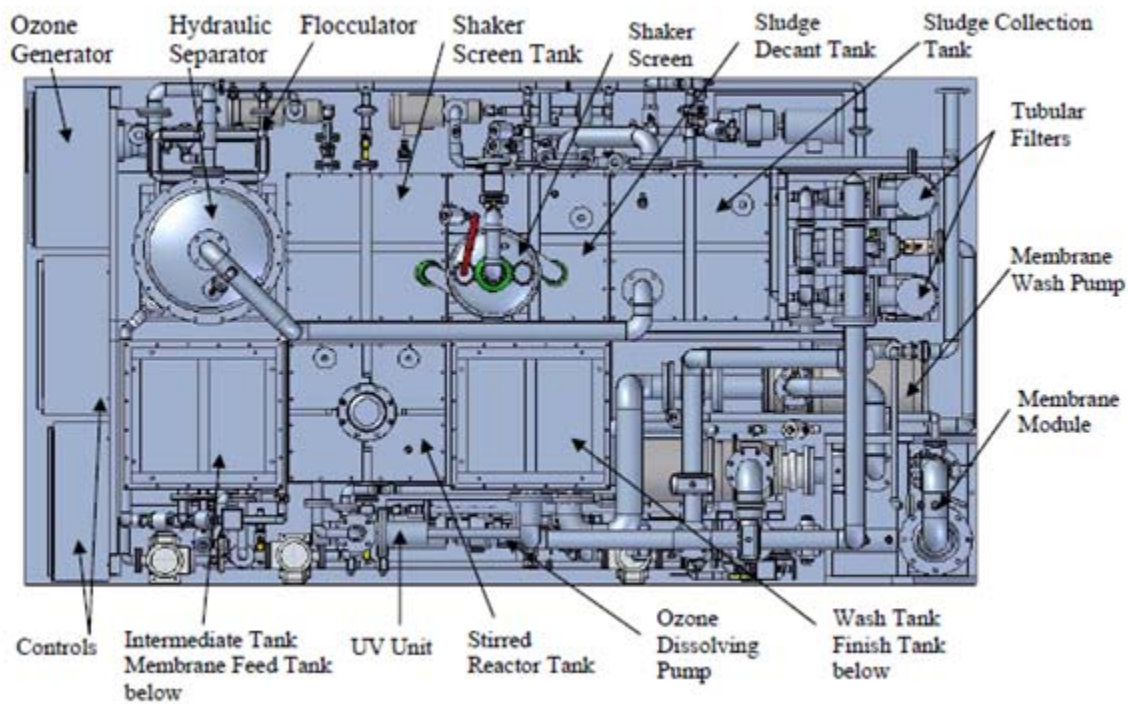

Figure 5. Aerial Isometric View of the Navalis Orion™ Advanced Oxidation Wastewater Treatment System

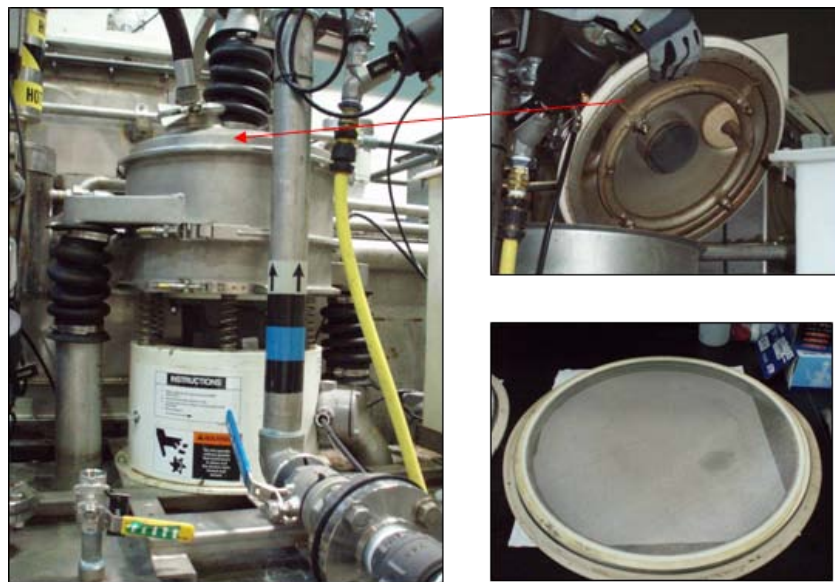

Figure 6. Photos of Covered Shaker Screen (left) with Top Cover (top right) and Screen (bottom right)

- **Shaker Screen** - The covered shaker screen is manufactured by SWECO with an 18-inch, 200 mesh screen. The unit serves to remove solids in the influent before entering the

treatment system. Figure 6 is a photo of the Covered Shaker Screen installed on the Navalis Orion™ system.

- **Flocculator** – The flocculator is Navalis-designed equipment which is basically, a length of pipe adding residence time to the screened wastewater and added flocculant chemical to increase reaction time and better promote solids separation. Figure 7 is a photo of the flocculator in front of the hydraulic separator unit.



Figure 7. Photo of Flocculator and Hydraulic Separator

- **Stainless Steel Tanks** - Many rectangular, stainless steel tanks of various volumes are utilized in the process. All tanks are similar with different heights and connections.
- **Hydraulic Separator** – The Hydraulic Separator is a 24-inch diameter stainless steel hydraulic lift dissolved air flotation device with a volume of 130 gallons. Solids will float to the top of the separator for periodic removal. Figure 9 shows the hydraulic separator installed behind the flocculator.
- **Dissolving Pumps** – The air, reactor ozone and sludge ozone dissolving pumps are all the same model Rogue Max RGT-10FS horizontal centrifugal pump.
- **Filters** – The Navalis Orion™ system contains two filter skids. The tubular filter skid consists of a set of 5-micron, poly pre-filters and associated piping and structural pieces. The membrane skid contains a 20-nanometer ceramic ultrafiltration tubular membrane module model Kerasep K37 manufactured by Novasep Orelis. Each module contains thirty-seven, 15-channel membranes. Both skids are depicted in Figure 8 along with photos of the bag filters and membrane, respectively. The membrane recirculation and wash pump is a Goulds close coupled 23SH.



Figure 8. Photos of Tubular Filter Skid (left) and Membrane Filter Skid (right)

- **Advanced Oxidation Stirred Reactor (AOSR)** – The AOSR is a stirred, media-packed, 2-foot diameter, stainless steel vessel with a volume of 150 gallons designed by Navaldis. Figure 9 is a photo of the AOSR tank with associated dissolving pump, UV unit and finishing tank. The figure on the right provides a close up view of the equipment.

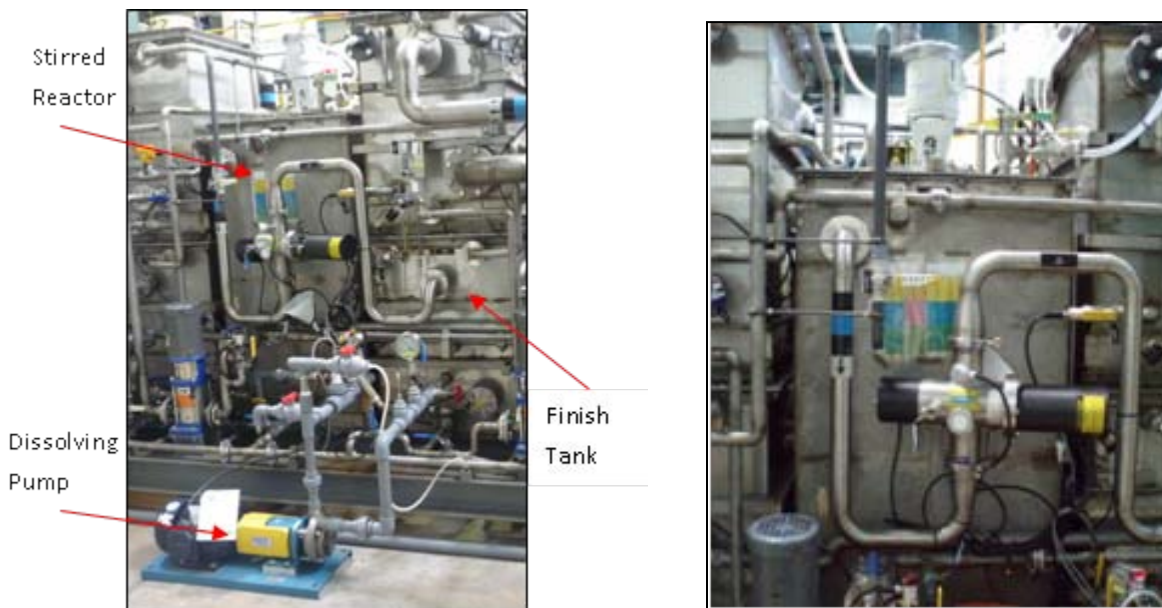

Figure 9. Photos of Advanced Oxidation Stirred Reactor (AOSR) (left) and Ultraviolet Unit (right)

- **Ultraviolet Disinfection Unit** – The UV unit is a Hyde Marine model In Line 20. The medium pressure, UV lamps placed in quartz sleeves inside a stainless steel vessel. The lamps do not come into direct contact with the effluent.

- **Ozone Generator** – The ozone generator is the Pacific Ozone Technology model Super SGA24 unit inside a standard NEMA IV electrical enclosure. Only the enclosure is visible on the unit. An air dryer is required to operate the ozone generator more efficiently. Both are depicted in Figure 10.

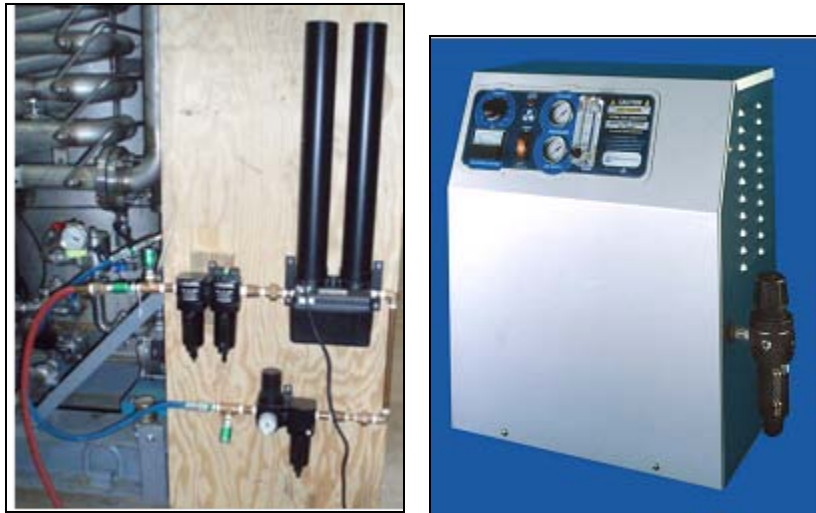

Figure 10. Photos of Twin Engineering Desiccant Air Dryer and Ozone Generator

- **Sludge Reduction and Management System** – The Sludge Reduction System is composed of rectangular tanks and associated piping and pumps.
- **System Pumps** – The feed and sludge decant pumps are Moyno 500 series pumps. The filter charge, filter backwash, membrane feed and discharge pumps are Goulds vertical model SSV pumps.

2.2 Technology Development

The advanced oxidation technology as applied by Navalis has been developed and proven with successful land-based prototype and pilot plants processing commercial wastewater. Waste Water Resources, Inc of Scottsdale, Arizona (an affiliated company of Navalis) reports that over 2 billion gallons of laundry water have been reclaimed using the Navalis advanced oxidation technology since the first unit was placed in-service in September of 2005. Table 1 contains references from current applications followed with photos of each installation in Figure 11.

Table 1. Navalis Advanced Oxidation Technology Applications

Installation Location	Installation Date	Avg Daily Flow	Wastewater
Crothall Hospital Services, Ontario, CA	September 2005	402 m ³	Industrial laundry
Texas Textile, Houston, TX	April 2006	197 m ³	Industrial laundry
Angelica, Phoenix, AZ (Prototype)	June–August 2005	440 m ³	Industrial laundry
Metropolitan Linen Service, Las Vegas, NV	March 2006	84 m ³	Industrial laundry
Navalis Orion™ Test Unit	June 2006	27.5 m ³	Laboratory (BW)
Metropolitan Linen Service, Las Vegas, NV	April 2007	3,200 m ³	Industrial laundry



Crothall Hospital Services
Ontario, CA

Texas Textile, Houston, TX

Angelica, Phoenix, AZ
Prototype Plant



Navalis Orion™ Test Unit, Scottsdale, AZ



Metropolitan Linen Service,

Figure 11. Photos of Navalis Advanced Oxidation Technology Applications

Since Navalis Orion™ Model 5 systems are not yet installed onboard cruise vessels, no data from the Alaska Department of Environmental Conservation (ADEC) or independent cruise ship data is available. A test was performed by a United States Coast Guard (USCG) Accepted Independent Material and Equipment Laboratory in March 2006 with the land-based Poseidon® treatment system processing combined BW and GW. The Navalis Poseidon® is a larger treatment system than the Navalis Orion™ system based on the same technology and components. The average of 40 samples showed that all effluent parameters were well within specification for all regulations. However, no influent data is available for that particular test. Many land-based systems tests, processing BW alone, GW alone and combined BW and GW, were performed by Navalis Environmental Systems over the years. Influent samples were obtained and can be compared to the performance specification influent ranges for BW and combined BW and GW. The combined BW and GW influent from Gainey Ranch is comparable to the performance specification ranges. For the BW influent for Gainey Ranch during the Poseidon® testing, BOD₅ was within the range specified in the performance specification but the TSS level was low. Average results from all tests were well within specification for all regulations and all parameters. The Navalis Orion™ system received USCG and International Maritime Organization (IMO) Type approval as a result of the March 2006 testing. The results are summarized below in Table 2.

Table 2. Navalis Orion™ and Poseidon® Analytical Data

Wastewater Source	Wastewater Type	n	BOD ₅ (mg/L)	TSS (mg/L)	FC (cfu/100mL)
Orion – Gainey Ranch, Mar 06 – Feb 07 Effluent Influent	BW/GW	25	<5 500-1500	BD 1500-2500	BD >36,600
Poseidon – Crothall Industrial Laundry Jun – Aug 05 Effluent Influent	GW	50	10 439	BD 54	BD >600
Poseidon Prototype – Gainey Ranch Jun 05 – Mar 06 Effluent Influent	BW	50	5-10 2750	BD 2500	BD >1000
Poseidon – USCG Test Mar 06 Effluent	BW/GW	40	4	ND	ND

BD = below detection

ND = not detected

2.3 Advantages and Limitations of the Technology

Implementing wastewater treatment systems shipboard is driven by regulatory compliance. Installation of a treatment system is not always cost effective, but is needed in order to meet regulations. Different methods and means can be employed to meet standards. Currently, tanks

are used to store wastewater until the ship can discharge in non-restricted waters. As regulations become more restrictive, either a treatment system must replace the existing holding tank, the ship mission must be altered to enable more frequent discharge in non-restricted waters, or the tank size must be increased. Although more costly than a tank, employing a treatment system is the best option in most cases. A shipboard wastewater treatment system will allow the ship more freedom to travel within restrictive waters for longer periods of time and to enter restrictive waters with little notice and preparation.

When compared to other advanced wastewater treatment systems, advanced oxidation treatment system advantages are the rapid startup capability, compact and modular design, and reduced operator interaction. Biological advanced wastewater treatment systems are used widely by the cruise industry, but require weeks to build a viable biomass to treat BW and GW successfully. Military missions are often unpredictable requiring rapid deployment and quick compliance with effluent standards. With advanced oxidation, effluent quality standards can be met in hours versus days, which allows vessels the flexibility of leaving port or modifying a mission with short notice.

Biological systems require larger reactors than advanced oxidation to allow the biomass to develop and reside. Advanced oxidation systems require less space and contribute less weight on a ship. In addition, the advanced oxidation systems can be applied to different shipboard collection systems and can handle BW that is either gravity collected/seawater flushed, or vacuum-collected/fresh water flushed.

Operation of biological systems often requires knowledge of bioreactors. Military vessels operate with frequent turnover of personnel who often do not have specialized training and who are not dedicated to the treatment system. Advanced oxidation technology can be automated and does not require parameter adjustments by the operator.

Conventional wastewater treatment systems usually classified as macerate/chlorinate and conventional biological treatment systems cannot consistently meet the new effluent requirements as shown by ADEC study results.[7] However, these systems are still employed on ships since they are certified by the USCG and approved by IMO to meet MARPOL requirements. Use of these systems meets current requirements for commercial vessels. Advantages of these systems are their size, weight and cost which are all less than those of advanced wastewater treatment technologies such as biological and advanced oxidation.

Automation of treatment systems is critical to reduce manning required to operate the equipment, but is a difficult task considering the variable waste stream produced onboard ship. The Navalis Orion™ system from the laboratory demonstration is automated, but still required assistance. This would be the case for any complex treatment system. Some additional disadvantages experienced during the demonstration are more system specific versus technology specific. The disadvantages associated with the Navalis Orion™ system are discussed in section 8 as implementation issues that could impact transition.

In summary, commercial systems are available, but are challenged by the special military needs of high strength wastewater, the need for fast startup in meeting effluent quality standards

quickly, and the lack of highly trained operators dedicated to a treatment system. All these factors, as well as size and weight restrictions, create barriers for seamless integration of commercial systems.

3.0 Performance Objectives

Table 3 lists the performance objectives that are essential for successful demonstration and validation of the advanced oxidation technology. The criteria include treatment capacity, reduction of key effluent quality parameters to meet the environmental regulations, startup time and the absence of critical component failures. These key quantitative performance requirements must be met during the laboratory evaluation.

Table 3. Performance Objectives

Performance Objective	Data Requirements	Success Criteria	Results
Meet Effluent Quality Standards	Effluent sample analysis data as specified by: * 33 CFR 159 * MEPC.159(55) * MIL-PRF-30099	BOD ₅ ≤ 25 mg/L COD ≤ 125 mg/L TSS ≤ 35 mg/L FC ≤ 100 cfu/100 mL 6 < pH < 8.5	Phase 1 – BOD ₅ and COD criteria not met Phase 2 – All criteria met
Meet Minimum Startup Time	Effluent sample analysis data	≤ 12 hrs	Phase 1 – Criteria not met Phase 2 – Criteria not met
Meet Treatment Capacity	Daily influent volume	Average daily volume processed: 6600 gpd for 12 days and Maximum daily volume processed: 7200 gpd for 3 days	Phase 1 – Criteria not met Phase 2 – Criteria not met
Demonstrate Level of Operator Involvement	Daily labor hours required for routine operation, maintenance and repair.	Run and record	Regular Daily Maintenance 5-40 minutes Special Maintenance 0.5 – 3 hours
Demonstrate System Reliability	Component failure data Documentation of equipment deficiencies and failures	No critical component failures MaxTTR ≤ 12 man-hrs (non-critical)	Phase 1 – Criteria met Phase 2 – Criteria not met

Many more tests were performed during the laboratory evaluation and are listed and described in MIL-PRF-30099. These tests are secondary to the performance objectives. The relevance of each objective along with the test results are described in the following sections.

3.1 Performance Objective: *Meet Effluent Quality Standards*

The primary measure of the effectiveness of the treatment system is the quality of the effluent. Current and future effluent parameters and their minimum values are identified by USCG regulations and MARPOL sewage standards from Resolution (Marine Environmental Protection Committee) MEPC.2(VI) and are listed in the performance specification.[8,9,10,6] The updated MARPOL requirements of Resolution MEPC.159(55) were added to Table 3 above.[11] The geometric mean of 40 samples must meet the success criteria values as stated in MEPC.159(55). The following analytes will be measured:

Five-day Biochemical Oxygen Demand (BOD₅). The amount of oxygen used by microorganisms that break down organic matter in water in five days. The analytical parameter is measured in milligrams per liter (mg/L).

Chemical Oxygen Demand (COD). The amount of a specified oxidant that reacts with the sample under controlled conditions. The quantity of oxidant consumed is expressed in terms of its oxygen equivalence. The analytical parameter is measured in milligrams per liter (mg/L).

Total Suspended Solids (TSS). A measure of the amount of suspended solids, both organic and inorganic, found in wastewater. The analytical parameter is measured in milligrams per liter (mg/L).

Fecal Coliform (FC). Organisms in the intestines of warm-blooded animals that are commonly used to indicate that fecal materials and organisms capable of causing human disease are present. The analytical parameter is measured in colony forming units per 100 milliliters (cfu/100mL) or “most probable number” per 100 milliliters (MPN/100mL).

pH. The intensity of the acidic or basic character of a solution or hydrogen ion activity.

In Phase 1 testing, the Navalix Orion™ system processed combined blackwater and graywater. The effluent BOD₅ and COD values were consistently higher than the desired standards, while both effluent TSS and FC thresholds were met. Even with very effective solids removal, the effluent BOD₅ and COD levels remained high. The high BOD₅ and COD values are an indication that the advanced oxidation step did not oxidize the organic contents sufficiently.

In Phase 2 testing, the Navalix Orion™ system processed blackwater alone. All effluent quality parameter thresholds were met.

3.2 Performance Objective: *Meet Minimum Startup Time*

One of the needs of military vessels is the ability to navigate littoral waters or leave port as required by mission. Biological treatment systems require weeks to cultivate an effective biomass within the bioreactor. Ideally, wastewater treatment systems onboard military vessels should meet effluent quality standards immediately or within hours. The startup time of the advanced oxidation treatment system will be determined by measuring the period of time beginning from the time of influent introduction to the treatment unit shaker screen and ending

with the time at which the first compliant sample of effluent is obtained. The goal for this test is a startup time of less than or equal to 12 hours as outlined in the performance specification. The daily processing rate must also meet the average hydraulic rate of 6600 gpd at the time compliance is met. The hydraulic rate will be calculated by dividing the totalized influent volume to the system at the time of sampling by the number of hours the system has been in operation at the time of sampling. The recycle stream volume will be documented via totalizing meter and will be subtracted from the influent volume.

The Navalis Orion™ system did not meet the minimum startup time in either test phase, since the capacity was not met.

3.3 Performance Objective: *Meet Treatment Capacity*

The treatment capacity of the advanced wastewater treatment system was validated by measuring the amount of wastewater processed per day less any recycled water from filter backwashes, retentate and decant. A mass balance was completed to determine the daily processing rate. The maximum processing rate of 7200 gallons per day was estimated by the manufacturer based on processing with wastewater generated by land-based operations. The performance specification requirements are for processing at the maximum hydraulic loading rate which is set by the manufacturer based on 24-hour operation. The average hydraulic loading rate is determined by back-calculating from the maximum hydraulic loading rate which is 110% of the average hydraulic loading rate. The average and maximum hydraulic loading rates must be processed for 80% of the test time and 20% of the test time, respectively. Based on a 15-day test, the maximum and average hydraulic loading rates must be processed for 12 days and 3 days, respectively.

Average Hydraulic Loading Rate = 6600 gallons per day for 12 days
Maximum Hydraulic Loading Rate = 7200 gallons per day for 3 days

In both Phase 1 and 2, the average and maximum processing rates of 6600 gpd and 7200 gpd were not attained. A large impairment of the system operation was due to the inefficiency of the Solids Separation Zone.

3.4 Performance Objective: *Demonstrate Level of Operator Involvement*

Some treatment technologies are complex and require specially-trained, dedicated personnel to ensure equipment operates effectively. A complicated, time-consuming treatment system is not desirable in the military. A simple, automated treatment system is the goal. In order to determine the level of required operator involvement, the actual labor hours spent in routine operation, maintenance and repair of the system, as well as, time spent managing sludge disposal and training were recorded. Each ship has a different mission, so each ship will determine if the operator requirements can be met.

In both phases, the system required operator involvement to operate and maintain the system for several hours per day. The details of daily operation and troubleshooting were documented in the laboratory logbook.

3.5 Performance Objective: *Demonstrate System Reliability*

To validate the reliability of the treatment system, component failure and maintenance data was monitored in the laboratory operator logs. The requirement is to achieve a Maximum Time To Repair (MaxTTR) of less than or equal to 12 man-hours for non-critical components as outlined in the performance specification. Qualitative information was gathered from operator logbook comments on equipment deficiencies.

During Phase 1, no critical components failed. The UV disinfection unit experienced leaks via the seals which caused inconsistent operation during Phase 2. The UV unit was actually not operational during several days of the test. The MaxTTR of 12 man-hours was not met.

4.0 Site/Platform Description

4.1 Test Platforms/Facilities

The Navalys Orion™ system was purchased for full-scale evaluation at the Non-Oily Wastewater Laboratory, a liquid waste laboratory facility at NSWCCD in West Bethesda, Maryland in building 60, room 175. The laboratory facility meets all criteria as a test site, including providing controlled feed composition, controlled feed volume and required utilities to the test equipment to simulate anticipated shipboard conditions with access to experienced wastewater technicians and engineers. Figure 12 contains photos of the laboratory during a few of the past evaluations.





Figure 12. Photos of NSWCCD Non-Oily Wastewater Laboratory Setup for Pilot and Full-Scale Tests

The Non-Oily Wastewater Laboratory contains holding tanks, treatment systems, and support equipment designed to test numerous shipboard contaminants and conditions to determine if a treatment technology is suitable for shipboard evaluation. The lab facility has the Liquid Waste Feed System (LWFS), an automated system programmed to deliver a specific mix of various wastewater sources in the lab to simulate the high strength wastewater. The treatment system is designed for a maximum flow rate of 5 gpm or 7200 gpd when operating 24-hours per day. The combined mixing and storage tanks volumes of the feed system can support a test to process the required maximum of 7200 gallons of aerated wastewater per day. All utilities were provided for the Navalis Orion™ system, including oil-free air, hot water, power and low pressure air. NSWCCD engineers have tested experimental equipment designs and commercial systems.

The NSWCCD laboratory receives wastewater from three sources. A BW surrogate is obtained from the primary clarifier at the Arlington County Water Pollution Control Division in Arlington, Virginia. Galley GW is from the Main Mess Hall of Fort Myers in Rosslyn, Virginia. The laundry water is from National Linen Service in Alexandria, Virginia.

4.2 Present Operations

The advanced oxidation technology or any other wastewater treatment technology is not intended to replace the current shipboard vacuum collection (Vacuum Collection, Holding and Transfer (VCHT)) or gravity collection (Collection, Holding and Transfer (CHT)) systems. Collection for blackwater and graywater will remain the same. However, instead of holding the wastewater for discharge overboard, the collected wastewater will enter the advanced oxidation treatment system. The treated effluent will then be discharged without holding. Some holding capacity will still be needed for the solids and sludge removed from the wastewater during processing, but it will be a fraction of the original holding volume required.

4.3 Site-Related Permits and Regulations

Carderock Environmental Safety and Health (ESH) and Naval Facilities Engineering Command (NAVFAC) reviewed the Laboratory Test Plan.

Untreated blackwater and graywater, effluent and sludge discharges to the drain are covered under the wastewater discharge permit authorizing discharges to the Blue Plains Wastewater Treatment Plant from NSWCCD. The permit is issued in accordance with the District of Columbia Pretreatment Regulations (DCMR Title 21 Chapter 15). NAVFAC at Carderock manages the permit. For Phase 1, the source of untreated blackwater and graywater was the same as in past laboratory evaluations, so NAVFAC reviewed past sampling data. Since past tests were allowed to discharge untreated blackwater and graywater, Phase 1 discharges to sewer were also allowed. For Phase 2, a new source was required. NAVFAC allowed discharges to sewer with concurrent sampling. However, since a Navalis system has not been tested by NSWCCD, the sludge quality was unknown. During testing, NAVFAC requirements were to sample the sludge and then discharge to drain.

During the Laboratory testing, a Carderock industrial hygienist performed the following testing with acceptable results:

- *Direct Read Noise* – measurement of the noise level at specific stations
- *Noise Dosimetry* – measurement of the noise based on an 8-hr average. The Navy allows 84 decibels for over an 8-hr day.
- *Ozone Levels* – measurement of the air ozone content based on an 8-hr average. During operation of the equipment and sampling, the technician will wear a pump in his breathing zone. The tube or filter will then be analyzed by a laboratory used by NSWCCD.

The NSWC Carderock Division has a site-wide Health and Safety Plan (HASP) for the laboratories. The Bethesda Site Chemical Hygiene Plan addresses responsibilities, rules and procedures, chemical handling protocol, air sampling, maintenance and inspections, medical surveillance, protective apparel, emergency equipment, records, labels and signs, chemical spill procedures and training.

5.0 Test Design

In the following test design section, an overview is provided for the laboratory testing.

5.1 Shock Risk Analysis

The performance specification contains a requirement for the treatment system to meet the shock requirements of MIL-S-901 for Grade B, Class 1 equipment. Grade B requirements specify that equipment does not need to be operational following a shock event, but must not come adrift, must not release toxic materials, and must not create an electrical hazard, such as an electrical short or fire. Shock testing is costly and potentially destructive for the test unit. The size of the treatment unit warrants the use of a Barge Test. Therefore, a shock risk analysis will be performed first.

A shock risk analysis is the first step towards performing a shock test. The analysis involves finite element modeling and the use of the Dynamic Design Analysis Method (DDAM).[12] The results of the DDAM identified potential failure points from system shock testing, which could be mitigated by developing more rugged designs for the failure points. The DDAM addressed the hazard of coming adrift in a shock event; however, MIL-S-901 (Shock Grade B criteria) also lists other hazards.[13] The analysis is not appropriate for all components of the system due to their geometry, configuration, complexity and failure mode, and should be subjected to shock testing in the future. The items not included in the analysis are the Control and Power Enclosures, Ozone Generator, Shaker Screen Module (Covered Shaker Screen and Shaker Tank), and Ultraviolet Treatment Unit.

Since the DDAM is the first step towards performing a shock test, it was performed concurrently with laboratory testing. Any additional actions to address shock testing, such as actual shock testing of the system or its components, would be considered following the completion of the DDAM and review of the results.

Navalis Environmental Systems performed the DDAM analysis with a portion of the work sub-contracted to O'Donnell Consulting Engineers. Oversight of the shock risk analysis was performed by NSWCCD Code 669, the Survivability and Weapons Effects Division, Ship Systems Hardening & Protection Branch. Code 66 develops vulnerability assessments of ships and submarines and provides the technology base (with a focus on testing: scaled-model, full scale and at-sea and analysis) required to enhance survivability and recoverability. Code 669 is the approval authority for DDAM analyses working for the Shock Warrant Holder, NAVSEA 05P13, reviewing and approving DDAM and transient analyses.

In general, this analysis was conducted by creating a three dimensional computer-aided design model of primary system components that were then entered into the finite element analysis tool, DDAM, for assessment. DDAM is used to evaluate the shock capability of various shipboard equipment and structures. The first step in the evaluation process is to develop a mathematical model to represent a piece of equipment or structure to an equivalent mass-elastic system. Ideally, the system is designed to sustain dynamic stresses induced by shock response motions. Stress levels are specified in the model. Forces and displacements associated with each mass and

structural element in the system are calculated by solving the equations of motion of a mass-elastic system. These forces and displacements are then used to calculate the stresses and deflections of various components of the equipment, the foundation and the hold-down means. Results are compared with specified allowable values to determine the acceptability of the analyzed items from a shock standpoint. The DDAM will determine if a component will detach from the system, but will not determine if the component itself will break apart.

The treatment system is a modular design that can be configured to meet specific installation requirements. Since it is modular, eleven typical modules were analyzed. Modules analyzed include; Membrane Module Frame, Tubular Filter Module Frame, Hydraulic separator tank with flocculator, Stirred Reactor Tank, Single process tank (shaker, intermediate, membrane feed, wash), Double process tank (two single tanks stacked), Sludge Collection Tank, Membrane recirculation/wash pump module, Typical vertical Goulds pump module, Typical ozone pump module, Typical pipe supports and details. These modules along with the controls, ozone generator and shaker screen are representative of the entire system no matter how it is configured for a particular installation. Each module was evaluated for hull-mounted use with unlimited shipboard orientation. Shock design inputs were provided by NAVSEA. For each module, a detailed analysis was performed and results and recommendations are presented in the report.

Dimensional data was accumulated and center of gravity was estimated for each of the modules. This information was then used to perform the analysis on each module. The natural frequencies of each module were calculated first. These frequencies were subsequently used to derive shock accelerations (the g-factors) in three directions according to the formulae provided by NSWCCD. There are two sets of shock design values relevant to this foundation analysis: Elastic and Elastic-Plastic. Elastic design values were applied for the bolt stress analyses. Elastic-Plastic design values were used for all other analyses, i.e., the foundation stresses, bolt plate stresses and weld stresses, as applicable. Standard DDAM coefficients were used for analysis of the Membrane Module, unclassified coefficients provided by NSWCCD Code 6690 were used for the remaining ten modules analyzed. The memorandum is included in Appendix B.

5.2 Laboratory Demonstration

The full-scale laboratory test followed the tests listed in the performance specification, MIL-PRF-30099. Each requirement was validated in one of three ways: examination, analysis or test. The examination process involved actual observance of requirements, such as physical size, physical interfaces and accessibility for maintenance. Analysis involved the review of certificates or data provided by the manufacturer to meet requirements such as system weight, materials of construction, and sensor calibration. Tests are designed to validate other requirements, such as hydrostatic pressure, data acquisition, control system operation and wastewater treatment performance. In total, the performance specification contains over 60 tests. Some tests were not performed if they did not apply to the advanced oxidation treatment system.

Requirements validated using examination and analysis of the treatment system were executed without actually processing wastewater. The system was required to process wastewater in several of the individual tests that comprised this evaluation.

The test of the Navalis Orion™ Advanced Oxidation Wastewater Treatment System was conducted in two phases. Phase 1 included preliminary analyses and examinations, initial checkout tests, and a minimum 15-day operating period during which Category B wastewater, combined blackwater and graywater, was processed. All the performance specification analyses, examinations, and tests were performed, except those omitted for practical reasons.

Phase 2 consisted of a repeat of the Phase 1 operating tests, processing Category A wastewater, blackwater only, for a minimum 15-day test period. All Phase 1 analyses, examinations, and checkouts were not repeated during Phase 2.

5.2.1 Test Influent

Navy shipboard wastewater organic loading rate data has been difficult to obtain due to the variable nature of the composition and rate of production of the waste stream. This is especially true for graywater, which varies from ship to ship and from day to day depending on ship operations, ship specific galley and scullery practices, and laundry use. Various sources of wastewater characteristics measured over the years by NSWCCD were collected and compiled as part of a feasibility study for shipboard graywater and blackwater treatment. A statistical analysis was performed using this data, and best estimates were generated. Average ranges of key parameters using these estimates are specified in the performance specification, which identifies four categories of wastewater, of which two, Category A (vacuum-collected blackwater influent) and Category B (combined vacuum-collected blackwater and gravity collected graywater), were used in this testing. The performance specification document is currently being updated, and Table 4 lists the updated key test influent parameters and ranges used for Phase 1 and 2 testing.

Table 4. Shipboard Wastewater Organic Loading Rates

System influent category	Parameter	40-Sample Average Range (mg/L)
Category A (vacuum – collected blackwater)	BOD ₅	780 – 1700
	TSS	2100 - 3500
	Oil and Greases (O/G)	50 - 120
Category B (combined vacuum – collected blackwater and gravity collected graywater)	BOD ₅	530 – 1300
	TSS	700 - 2400
	O/G	100 - 220

The performance specification indicates the duration of the processing test as 10 consecutive days. With the limitations of a maximum 6-hour hold time on the fecal coliform samples and the laboratory hours of operation, NSWCCD only submitted three sets of samples per day, not four as outlined by the specification. For this reason, each test phase was extended to a

minimum of 15 weekdays to collect and analyze the 40 sample sets required by the performance specification.

5.2.2 Phase 1 Testing

Phase 1 of the test consisted of four parts: examinations, analyses, pre-operational tests, and operational tests. The four parts corresponded to tests required by the performance specification in sections 4.2 through 4.4. The performance specification contains a list of publications used in the Field Testing sections. The four parts were accomplished in the order listed below.

5.2.2.1 Examinations

The first part of Phase 1 consisted of visual and dimensional examination of the test system. The examination tests correspond to section 4.2 in the performance specification. The examinations were performed before operating the equipment to determine whether any aspects of these requirements merited further observation during operation.

The performance specification is written to support acquisition of a treatment system with a specific application. Some of the requirements are determined by the physical characteristics of the ship or its mission. Since this test is not associated with a ship procurement, these parameters were measured and recorded, but no “pass/fail” criteria were applied.

Test 1-1, Physical Size – Measure and record the total physical size of the system and access envelopes.

Test 1-2, Modularity – Confirm that all system parts and consumables that will require replacement during the service life of the ship are capable of passing through standard U.S. Navy doorways (26 in. wide by 66 in. high, with 8-in. radius corners) and hatches (30 in. wide by 60 in. long, with 7.5-in. radius corners). The service life of the ship is assumed to be 30 years.

Test 1-3, Backflow Prevention – Confirm that the system is capable of preventing back flow of wastewater, through shipboard/laboratory system supply and discharge interfaces.

Test 1-4, Properties of Discharged Vapor Gas – Confirm that the system is vented or provided with some means to prevent an explosion or over pressurization resulting from an accumulation of gases. Confirm that all tanks or components where such accumulation may occur are protected.

Test 1-5, Ship Physical Interface – Confirm that the system interfacing piping is compatible with mating shipboard interface connections as referenced in Table III of the performance specification.

Test 1-6, Accessibility – When installed in a specified ship class, all major system assemblies, attachments, and retention tanks are accessible for maintenance, repair, and replacement without requiring the removal of other major assemblies and temporary attachments. Confirm that the maintenance access for tanks is located near the tops of the tanks with an external access ladder

if necessary. Confirm that access has been provided to inspect or routinely replace components, without the need to remove system components other than an access door or hatch.

Test 1-7, Sampling Ports – Confirm that sampling ports have been provided for manual sampling of the system’s influent, treated effluent, and sludge (if applicable).

Test 1-8, Redundant Pumps – Confirm that the system incorporates 100 percent redundancy for all pumps that are critical to meet system performance.

Test 1-9, Identification Markings – Confirm that all system parts have permanently affixed and legible markings identifying the manufacturer’s name, model and serial number, and inspection lot identification. Also confirm that the electrical enclosure identifies the voltage, frequency, maximum horsepower rating, and low noise, if necessary, and that piping identify its specific service, pressure, size, and flow direction.

5.2.2.2 Analyses

The second part of Phase 1 included evaluations and analyses based on material submitted by the vendor. The analyses tests correspond to Section 4.3 of the performance specification and can include drawings, specifications, design data, receiving inspection records, processing and quality control standards, vendor catalogs and certifications, industry standards, test reports, and rating data. These evaluations were performed before operating the equipment to determine if any aspect of the treatment system merits further observation during operation.

Test 1-10, Material – Inspect manufacturer’s records for proof or certification and confirm that materials conform to requirements.

Test 1-11, System Weight – Measure and record the total wet weight of the system.

Test 1-12, Treated Effluent and Process Wastes Removal – Confirm that the system removes the treated effluent and process waste at a discharge pressure that overcomes the static head loss.

Test 1-13, Tank Volume – Calculate and record the total volume of ship’s tanks or laboratory tanks required by this system.

Tests 1-12 and 1-13 use vendor-supplied information to calculate key volumes. In a normal procurement, these calculations measure the system’s ability to meet the performance specification requirements for a specific ship class. Since the test is not associated with a ship procurement, these volumes were calculated and recorded, but no “pass/fail” criteria were applied.

Test 1-14, Consumables Volume – Calculate and record the volume required to store any consumables needed to support system operation for a six-month deployment.

Test 1-15, Operational Availability – Calculate the operational availability (A_0) to support system operation for a six-month deployment. A_0 must be no less than 0.9 over a six-month deployment.

Test 1-16, MTBCF – Calculate the mean-time-before-critical-failure (MTBCF) using reliability prediction methods. MTBCF must be no less than 4320 hours based on a six-month deployment.

Test 1-17, Maintenance Ratio – Calculate the maintenance ratio using test data obtained during operational testing. The maintenance ratio must not exceed 0.03 over a six-month deployment.

Test 1-18, MTTR and MaxTTR – Calculate the mean-time-to-repair (MTTR) and maximum-time-to-repair (MaxTTR) using test data for corrective maintenance performed during operational testing. The MTTR and MaxTTR must not exceed 5 hours and 12 hours, respectively. These will be calculated after operational testing is complete. MTTR results will not be used in a go/no-go decision for shipboard testing.

Tests 1-15 through 1-18 were calculated after operational testing was complete.

Test 1-19, Safety – Request a review by NSWCCD Environmental Safety and Health (ESH) Office personnel to confirm that the system presents no safety or health hazards to operating or maintenance personnel, either during operation or while the system is secured. The analysis should include confirmation of the system's ability to safely transfer and hold all malodors, gases, smoke, and toxic substances, including collected wastewater, without risk of contamination or exposure to personnel. Demonstrate safety recommendations during the operational testing.

Test 1-20, Sensors – Inspect manufacturer's records for proof or certification and confirm that sensors are calibrated and conform to requirements.

Test 1-21, Chemicals in the Influent – Obtain a list of common and shipboard chemicals and corresponding volumes of those chemicals that may be detrimentally affect treatment system performance.

5.2.2.3 Pre-Operational Tests

The third part of Phase 1 included preliminary tests of the control system and operational modes, as well as a hydrostatic test. All tests requiring fluids were conducted using potable water.

The specific requirements and verification methods mandated by the performance specification are discussed below. All numbers in parentheses following each test refer to the performance specification paragraphs that define the requirements for that test.

Test 1-22, Hydrostatic Integrity (4.4.1) – Hydrostatic testing will not be conducted during the laboratory evaluation. The manufacturer will perform this test prior to delivery and NSWCCD will obtain the documentation and record the results.

Ship environmental compatibility tests as specified in the performance specification were not conducted, because the system was not associated with a specific ship procurement.

Tests 1-23 through 1-26 are designed to confirm that the Navalis Orion™ system controls provide all of the required operating modes, monitoring and control functions, and alerts and alarms. For tests that are system-dependent, the following paragraphs describe only their basic principle and purpose. The detailed tests and checklists used during the test are included in Appendix C.

Test 1-23, Electrical Power Interface (4.4.3.1) – Confirm that the system is compatible to the shipboard electrical supply as defined in MIL-STD-1399.

Test 1-24, Grounding and Bonding (4.4.3.2) – Confirm that the system’s electrical and electronic equipment grounding and bonding potentials and radio frequency impedance do not exceed the limit specified in MIL-STD-1310. This test must be repeated if a shipboard installation is performed.

Test 1-25, Operating Modes (4.4.3.3a) – Turn the system power on and, using the control panel in accordance with the manufacturer’s instructions, confirm that the control system satisfies the operational requirements in the performance specification (4.4.3.3). The control system should have the following (or equivalent) operating modes: Start-up, Standby, Process, Manual, and Shutdown. A separate test plan will contain a description of the operating modes and a detailed checklist for the test.

Test 1-26, Monitoring and Control (4.4.3.3b-e, g) – Confirm that the control system operates as specified in the monitoring and control section of the performance specification (4.4.3.3). Confirm that all mode switching occurs without any electronic errors, and that the display clearly indicates the current operating mode and allows operator access to all operating modes and conditions. Confirm that all sub-systems self-monitor critical operating parameters, such as flow and pressure, and that the system is controlled by a Programmable Logic Controller (PLC) or equivalent. Confirm that the system will go into an automatic fail-safe shutdown upon entering any operating condition that could result in damage to the equipment or danger to personnel. Confirm that the system automatically restarts operation after power is restored after an interruption. Confirm that all sensors display readings throughout the test.

Confirm that the system includes local and remote emergency shutdown switches. Separately activate the two switches to confirm that each switch shuts the system down in a controlled manner that does not damage the equipment or endanger personnel. A separate test plan will contain a description of the monitoring and control functions of the treatment system and a detailed checklist.

Test 1-27, Audible Alerts and Alarms (4.4.3.3f) – Confirm that the system provides audible alerts and alarms that satisfy the following requirements:

- all audible alerts and alarms sound locally
- the operator can acknowledge (deactivate) the alarm signal and silence/mute the audible signal for silent operations

- all audible alerts and alarms remain active until acknowledged by the operator
- all audible alerts and alarms employ procedures to prevent inadvertent or nuisance trips during transient operations, such as system start-up, shutdown, or from transient conditions, such as electrical spikes or pulses, electronic noise, ship's dynamic motion.
- all audible alerts and alarms are capable of being tested at the control panel.

Confirm that audible alerts are provided for the following:

- degraded operations
- failure of one or more non-critical components
- maintenance action required
- low consumables
- power supply interruptions.

Confirm that audible alarms are provided for any operating condition that might result in damage to the system or endanger the ship or personnel. A separate test plan will contain a list of audible alerts and alarms for the treatment system and a detailed checklist for the test.

Test 1-28, Visual Alerts and Alarms (4.4.3.3f) - Confirm that the system provides visual alerts and alarms that satisfy the following requirements:

- visual alerts and alarms display locally
- the operator can acknowledge (deactivate) the alert or alarm
- all visual alerts and alarms remain active until acknowledged by the operator
- all visual alerts and alarms indicate what caused the alert or alarm
- all visual alerts and alarms employ procedures to prevent inadvertent or nuisance trips during transient operations (i.e., system start-up, shutdown) or from transient conditions (i.e., electrical spikes or pulses, electronic noise, ship's dynamic motion)
- all visual alerts and alarms are capable of being tested at the control panel.

Confirm that visual alerts are provided for the following:

- degraded operations
- failure of one or more non-critical components
- maintenance action required
- low consumables
- power supply interruptions.

Confirm that visual alarms are provided for any operating condition that might result in damage to the system, or endanger the ship or personnel. The test plan will contain a list of visual alerts and alarms for the treatment system and a detailed checklist for the test.

5.2.2.4 Operational Tests

The fourth part of Phase 1 included tests of the system's ability to meet the specification's performance requirements, i.e., its ability to produce an effluent that is acceptable for overboard

discharge while operating at the manufacturer's recommended processing rate. Some of the operational tests are ship-dependent. For these tests, the following paragraphs describe only the basic principle and purpose for each test. The detailed tests and checklists used during the test are included in Appendix C.

Test 1-29, Processing and Effluent Quality Test (4.4.4.1a-b) – Perform a processing test beginning with a cold start test as described in the performance specification. This processing test is the main evaluation procedure of the performance specification and will demonstrate compliance with effluent discharge standards and processing capabilities. The hydraulic loading schedule will consist of:

- 6600 gpd (100% of average daily flow rate) – 80% of test duration or 12 days.
- 7200 gpd (110% of average daily flow rate) – 20% of test duration or 3 days.

To confirm startup time, additional samples will be obtained during the first 12 hrs of processing. The processing rate at the time of sampling will be documented.

Test 1-30, Process Wastes Holding Test (4.4.4.1c) – During the processing test, determine the system solids holding capacity. According to the performance specification (4.4.4.1.c), the system must be able to retain all solids from the sludge tank and aerated storage tank for the period required by the specified ship's mission for near-shore operation. The solids-holding capacity will be recorded even though the Navalis Orion™ system testing is not associated with a specific ship procurement.

Test 1-31, Safety - Observe system operation throughout the processing test to confirm that the system presents no safety or health hazard to the ship or personnel during any phase of operation.

Test 1-32, Data Acquisition/Retrieval (4.4.4.1d) – During the processing test, confirm that the data acquisition and retrieval capabilities meet the requirements, as described in the performance specification. View the status of all saved data once a day, to confirm that data is stored in accordance with the manufacturer's specifications. Do not erase any data until the end of the processing test to confirm that the system can store and retrieve data for the period specified by the manufacturer.

Test 1-33, System Drain – Upon conclusion of the processing test, drain the system in accordance with the manufacturer's instructions. Confirm that the system drains completely.

Test 1-34, Tank Washdown Test (4.4.4.1g) – Upon conclusion of the system drain test, perform a tank cleaning test in accordance with the performance specification. Wash down the internal surfaces of the surge and effluent tanks using either treated effluent or freshwater. Confirm the effectiveness of the cleaning and that all wash water and tank residue are discharged from the system.

Test 1-35, MTBF (4.4.5) – Document equipment issues and failures in order to calculate the MTBF. The MTBF is required to be no less than 500 hours at a 90 percent confidence level.

Test 1-36, Human Factors (4.4.7) – Confirm that all man-to-machine interfaces, such as controls, displays, alerts, alarms, labeling, environment, and accessibility, are suitable for user personnel with fifth to ninety-fifth percentile anthropometric data as defined in ASTM F 1166-95a.

5.2.3 Phase 2 Testing

Phase 2 of the test consisted of an additional minimum 15-day period of operation processing blackwater only influent with the same hydraulic loading as Phase 1. During Phase 2, compliance with the operating requirements and some analyses of Phase 1 were re-evaluated with the new waste stream. Only those Phase 1 requirements that could be affected by the different waste stream were retested in Phase 2.

5.2.3.1 Examination

These tests were not repeated during Phase 2, since the physical system was not changed.

5.2.3.2 Analyses

Tests 1-14 through 1-18 were repeated to collect additional operational data in order to confirm reliability parameter values from Phase 1.

Test 2-1, Consumables Volume – Calculate and record the volume required to store any consumables needed to support system operation for a six-month deployment.

Test 2-2, Operational Availability – Calculate the operational availability (A_0) to support system operation for a six-month deployment. A_0 must be no less than 0.9 over a six-month deployment.

Test 2-3, MTBCF – Calculate the mean-time-before-critical-failure using reliability prediction methods. MTBCF must be no less than 4320 hours based on a six-month deployment.

Test 2-4, Maintenance Ratio – Calculate the maintenance ratio using test data obtained during operational testing. The maintenance ratio must not exceed 0.03 over a six-month deployment.

Test 2-5, MTTR and MaxTTR. – Calculate the mean-time-to-repair and maximum-time-to-repair using test data for corrective maintenance performed during operational testing. The MTTR and MaxTTR must not exceed 5 hours and 12 hours, respectively. These will be calculated after operational testing is complete. MTTR results will not be used in a go/no-go decision for shipboard testing.

Tests 2-2 through 2-5 were calculated after operational testing was complete.

5.2.3.3 Pre-Operational Tests

These tests were not repeated during Phase 2, since the physical system and the design of its operation were not changed.

5.2.3.4 Operational Tests

Tests 1-29 through 1-35, from Phase 1, were repeated to determine performance of the treatment system while processing the new waste stream.

Test 2-6, Processing and Effluent Quality Test (4.4.4.1a-b) – Perform a processing test beginning with a cold start tests as described in the performance specification. This processing test is the main evaluation procedure of the performance specification and will demonstrate compliance with effluent discharge standards and processing capabilities. The hydraulic loading schedule will be the following:

- 6600 gpd (100% of average daily flow rate) – 80% of test duration or 12 days.
- 7200 gpd (110% of average daily flow rate) – 20% of test duration or 3 days.

To confirm startup time, additional samples will be obtained during the first 12 hrs of processing as indicated in Section 5.5.2. in the Sampling Plan Table 6. The processing rate at the time of sampling will be documented.

Test 2-7, Process Wastes Holding Test (4.4.4.1c) – During the processing test, determine the system solids holding capacity. According to the performance specification (4.4.4.1.c), the system must be able to retain all solids from the sludge tank and aerated storage tank for the period required by the specified ship’s mission for near-shore operation. The solids holding capacity will be recorded even though the Navalis Orion™ system testing is not associated with a specific ship procurement.

Test 2-8, Safety - Observe system operation throughout the processing test to confirm that the system presents no safety or health hazard to personnel during any phase of operation.

Test 2-9, Data Acquisition/Retrieval (4.4.4.1d) – During the processing test, confirm that the data acquisition and retrieval capabilities meet the requirements as described in the performance specification. View the status of all saved data once a day to confirm that data is stored in accordance with the manufacturer’s specifications. Do not erase any data until the end of the processing test to confirm that the system can store and retrieve data for the period specified by the manufacturer.

Test 2-10, System Drain – Upon conclusion of the processing test, drain the system in accordance with the manufacturer’s instructions, as described in the performance specification. Confirm that the system drains completely.

Test 2-11, Tank Washdown Test (4.4.4.1g) – Upon conclusion of the system drain test, perform a tank cleaning test in accordance with the performance specification. Wash down the internal surfaces of the surge and effluent tanks using either treated effluent or freshwater. Confirm the effectiveness of the cleaning and that all wash water and tank residue are discharged from the system.

Test 2-12, MTBF (4.4.5) – Document equipment issues and failures in order to calculate the MTBF. The MTBF is required to be no less than 500 hours at a 90 percent confidence level.

5.2.4 Measurement/Monitoring Plan

The specific parameters measured during the evaluations to evaluate the performance of the system are the following:

- Analytical parameters for the influent, effluent and sludge
- Volumetric flow rates of the influent, effluent and sludge
- Totalized daily volume of influent, effluent and sludge

The sections below describe the detailed methods and equipment used to perform the measurements.

5.2.4.1 Standard Test Methods

Standard test methods were employed to obtain the BOD₅, COD, TSS, O/G, FC and Metals data. The pH was measured using litmus paper or a commercial pH probe. Table 5 lists the Standard Methods test used for each analyte from “Standard Methods for the Examination of Water and Wastewater.” [14] A brief description of each test is also listed after the table.

Table 5. Analytical Methods

Analyte	Standard Test Method
BOD ₅	Std Method 5210B
COD	Std Method 5220D
TSS	Std Method 2540D
O/G	Std Method 5520B
FC	Std Method 9221C,E
Metals	Std Method 3120B, 3112B

Five-day Biochemical Oxygen Demand (BOD₅). The amount of oxygen used by microorganisms that break down organic matter in water in five days. The analytical parameter is measured in milligrams per liter (mg/L).

The Standard Method 5210B test determines the relative oxygen requirement of wastewater. The test measures oxygen utilized during an incubation period of 5 days for the biochemical degradation of organic material (carbonaceous demand). The method consists of a sample dilution, seeding and incubation at 20±1°C for 5 days. Dissolved oxygen is measured before and after incubation to quantify BOD₅.

Chemical Oxygen Demand (COD). The amount of a specified oxidant that reacts with the sample under controlled conditions. The quantity of oxidant consumed is expressed in terms of its oxygen equivalence. The analytical parameter is measure in milligrams per liter (mg/L).

The Standard Method 5220D is an open reflux procedure where a known excess of potassium dichromate is added to the sample along with sulfuric acid reagent and then refluxed for 2 hours. Unreduced potassium dichromate is titrated and used to determine the amount consumed. The amount of oxidizable matter is calculated in terms of oxygen equivalent.

Total Suspended Solids (TSS). A measure of the amount of suspended solids, both organic and inorganic, found in wastewater. The analytical parameter is measured in milligrams per liter (mg/L).

TSS is a component of Total Solids and is the portion of solids left behind on a filter following filtration while dissolved solids pass through the filter. The Standard Method 2540D for TSS consists of filtering a sample and drying the solids retained to a constant weight at 103-105°C.

Oil and Grease (O/G). Oils represent the set of greasy substances that are liquid or can be liquefied easily, and that are soluble in solvents but not water. Greases represent the set of thick, oily, lubricant substances that can be formed of material such as lard, rendered fats, or from petroleum-derived or synthetic oils containing thickening agents. The analytical parameter is measured in milligrams per liter (mg/L).

Although this parameter is not a discharge requirement, O/G is measured to help determine the quality of influent processed. The U.S. Navy blackwater and graywater typically contains a high level of oil and greases. To ensure that a minimum strength wastewater is processed by the test equipment, the performance specification includes the O/G range that the influent quality must meet.

Standard Method 5520B utilizes n-Hexane as the extracting solvent for dissolved or emulsified oil and grease from water via a liquid-liquid, partition-gravimetric method. The sample is acidified to a pH of 2 or lower with hydrochloric acid or sulfuric acid and then transferred to a separatory funnel with n-Hexane used to rinse the sample bottle. In the separatory funnel, the aqueous component of the sample is drained. The remaining solvent in the funnel is filtered into a flask. The solvent is distilled from the flask using a water bath of 85°C. The flask is cooled in a desiccator until a constant weight is obtained. A solvent recovery procedure is also included and recommended.

Fecal Coliform (FC). Organisms in the intestines of warm-blooded animals that are commonly used to indicate that fecal materials and organisms capable of causing human disease are present. The analytical parameter is measured in colony forming units per 100 milliliters (cfu/100mL) or “most probable number” per 100 milliliters (MPN/100mL).

In the Standard Method 2540E, elevated temperature tests are used to distinguish those total coliforms which are also part of the fecal coliform group. The sample is added to an EC or A-1 medium in fermentation tubes and incubated at $44.5 \pm 0.2^\circ\text{C}$ for 24 ± 2 hours. Gas production is a positive indication for the presence of fecal coliform. Method 9221C is then used to quantify the results in terms of MPN.

Metals. The metals content of the sludge was measured to determine discharge status during testing and for information on how to handle disposal onboard ship.

The standard testing for metals includes two separate tests, one for total metals content and trace elements and the second specifically for quantifying mercury. Standard Method 3120B uses plasma emission spectroscopy to quantify total metals in samples. Standard Method 3112B utilizes cold-vapor atomic absorption spectroscopy.

pH. The intensity of the acidic or basic character of a solution or hydrogen ion activity.

For this test, commercial litmus paper and a commercial pH probe were both used.

5.2.4.2 Sampling Plan

The required number of samples per day is stated in Section 4.4.4.3 Sampling and Analysis in the performance specification. The USCG and IMO requirements also use the number of 40 samples in testing. The performance specification states that the sampling rate should be four samples per day. However, due to the limitations of the analytical laboratory, only three samples per day were obtained. The analytical services were provided by Martel Laboratories_{JDS} Inc. in Baltimore, Maryland. The sampling plan is summarized in Table 6.

Table 6. Sample Schedule for the Laboratory Demonstration (Phase 1 and 2)

Sample Location	Samples Required						
	BOD ₅	COD	TSS	O/G	FC	Metals	pH
Influent (startup)*	1,1,3	1,1,3	1,1,3	1,1,3	1,1,3		1,1,3
Effluent (startup)*	1,1,3	1,1,3	1,1,3		1,1,3		1,1,3
Influent	40	40	40	40			40
Intermediate**	40	40					
Effluent	40	40	40		40		40
Sludge			40			40	

* Samples were taken at 4 hrs, 8 hrs and 12 hrs.

** Samples were only obtained during Phase 2 at the ceramic membrane effluent

The laboratory Phase 1 sampling plan consisted of three sampling episodes per day on weekdays only. Samples were obtained at approximately 0600 hours, 1000 hours and 1400 hours. As requested by NAVFAC, samples were also collected from the sludge tank drain once per day at 1000 hours. In addition to the samples required by the performance specification, samples were obtained to gain additional performance data for the Naval Orion™ system. Samples were collected from the sludge tank to determine the solids content and concentration of metals. To confirm the startup time of the system, samples were obtained after the initial 4 hours, 8 hours and 12 hours of operation. Single samples of each parameter were obtained for the 4 hour and 8 hour sample times, with triplicate samples obtained for the 12 hour sample point.

Most of the Phase 2 sampling frequency and required tests were the same as those for Phase 1. The purpose of the evaluation was not to perform a detailed analysis of each unit operation in the system, but to test a commercial system in automatic mode with little operator interaction. So, intermediate values for parameters were not obtained in Phase 1. However, with the unexpected performance in Phase 1, modifications were made to the system to improve performance and troubleshooting capabilities for Phase 2. Several intermediate sample points exist throughout the process. For Phase 2, an intermediate sampling point was located between the ceramic membrane and the reactor at the permeate discharge to the reactor tank. The measurement of the influent BOD₅ and COD concentrations to the AOSR was of particular interest to help explain the effectiveness of the advanced oxidation step. A second intermediate sampling point was located before the AOSR. Two in-line dissolved ozone sensors were installed in the stream entering the reactor after the ozone dissolving pump. The dissolved ozone concentration levels entering the advanced oxidation stage would help explain the effectiveness of the reactor.

5.2.4.3 Laboratory Measurement Equipment

The influent, effluent and sludge flowrates were measured by electromagnetic flowmeters manufactured by Endress and Hauser. The Proline Promag Model 53P50-EL0B1RC2BAAA is designed to measure wastewater flow in piping. The flowmeters were connected to the LWFS which logged the totalized flow from each flowmeter daily.

6.0 Performance Assessment

6.1 Shock Risk Analysis

The Navalis Orion™ treatment system was evaluated to standard US Navy requirements of Grade B Shock using the Dynamic Design Analysis Method (DDAM).[12] The treatment system is a modular design that can be configured to meet specific installation requirements. Since it is modular, eleven typical modules were analyzed. Modules analyzed include; Membrane Module Frame, Tubular Filter Module Frame, Hydraulic separator tank with flocculator, Stirred Reactor Tank, Single process tank (shaker, intermediate, membrane feed, wash), Double process tank (two single tanks stacked), Sludge Collection Tank, Membrane recirculation/wash pump module, Typical vertical Goulds pump module, Typical ozone pump module, Typical pipe supports and details. These modules along with the controls, ozone generator and shaker screen are representative of the entire system no matter how it is configured for a particular installation. Each module was evaluated for hull-mounted use with unlimited shipboard orientation. Shock design inputs were provided by NAVSEA. For each module, a detailed analysis was performed and results and recommendations are presented in the report.

In summary, all of the modules except for the pumps and pipe supports were found to be inadequate for various reasons ranging from size and number or mounting bolts to tank wall thickness and support member size. All of the potential problems discovered in the analysis are documented and recommendations are made on how to mitigate identified problems.

Code 669 reviewed the DDAM shock analysis report (Navalis Report NES USN7023-008) and confirmed that the method used for the analysis is correct. A memo from Code 669 is included in Appendix D. Code 669 is the Survivability and Weapons Effects Division, Ship Systems Hardening and Protection Branch and has expertise in shock testing and provides oversight and reviews for DDAM analyses for the Navy.

Results from each module analysis and other equipment are detailed below. The following excerpts were taken from the report entitled, “Shock Analysis Report,” written by Navalis Environmental Systems, LLC, 29 May 2009. The full report is provided in Appendix E.

6.1.1 Modules Analyzed

Membrane Module

The scantlings of the membrane module frame structure as given were found to be adequate for DDAM shock. The worst-case frame stresses resulted from a Vertical shock. Bolt sizing calculations show that the ½-inch diameter equipment mounting bolts are overloaded by a Vertical shock model (y-direction). One additional ½-inch foundation bolt should be added on each side of the frame structure to reduce the bolt stresses.

Tubular Filter Module

The scantlings of the structure as designed were found to be inadequate for DDAM shock. The frame structure base channels and main uprights are overstressed for all directions of shock. Heavier channels for the uprights, and heavier channels or the addition of stiffeners between the channel flanges of the base are recommended. Bolt sizing calculations show that the ½-inch diameter Grade 5 mounting bolts are overloaded for all directions of imposed shock. Bolts of a 5/8-inch diameter and of Grade 5 should be used and one additional foundation bolt should be added on each side of the frame structure to reduce the bolt stresses.

Hydraulic Separator Tank with Flocculator

The scantlings of the structure as given were found to be inadequate for DDAM shock. The worst-case stresses resulted from a Vertical shock. The base support channels are of insufficient strength to satisfy the stress limits when subjected to Vertical and transverse direction shock. A heavier channel is recommended and a larger footprint will mitigate a portion of the overturning effects. Overstresses are observed at the tank to base connection locations. Additional interface length, such as by way of a base plate on top of the channels, is recommended. Such a plate would also reduce observed overstresses in the tank bottom. Bolt sizing calculations show that the ½-inch diameter Grade 5 equipment mounting bolts are overloaded for all directions of shock loading. Bolts of a 5/8-inch diameter and of Grade 8 should be used and one additional foundation bolt should be added on each side of the frame structure to reduce the bolt stresses. The interfaces between the angle beams supporting the flocculator and the separator tank need to be modified for improved shock resistance. Additional structure is needed to better distribute the load from the beams onto the tank shell.

Stirred Reactor Tank

The scantlings of the structure as given were found to be inadequate for DDAM shock. The worst-case stresses resulted from a Vertical shock. The walls of the tanks are too thin to satisfy the stress limits when subjected to Vertical shock. A 50% increase in wall thickness is recommended. A wall thickness increase will affect the potential for splitting at wall corner seams. Such an evaluation is deferred until membrane overstresses are appropriately addressed. Bolt sizing calculations show that the ½-inch diameter Grade 5 equipment mounting bolts are overloaded for all directions of shock loading. Bolts of a 5/8-inch diameter and of Grade 8 should be used and one additional foundation bolt should be added on each side of the frame structure to reduce the bolt stresses.

Single Process Tank Module

The scantlings of the structure as given were found to be inadequate for DDAM shock. The worst-case stresses resulted from a Vertical shock. The addition of mid-wall vertical stiffeners at the bottom of the tank is recommended to reduce the potential for tank leakage following a shock event. Bolt sizing calculations show that the ½-inch diameter Grade 5 equipment mounting bolts are overloaded by a Vertical shock (model y-direction). Bolts of a 5/8-inch diameter and of a

Grade 8 should be used and one additional 5/8-inch foundation bolt should be added on each side of the frame structure to reduce the bolt stresses.

Double Process Tank Module

The scantlings of the structure as given were found to be inadequate for DDAM shock. The worst-case stresses resulted from a Vertical shock. The walls of the tanks are too thin to satisfy the stress limits when subjected to Vertical shock. A 50% increase in wall thickness is recommended. A wall thickness increase will affect the potential for splitting at wall corner seams. Such an evaluation is deferred until membrane overstresses are appropriately addressed. Bolt sizing calculations show that the ½-inch diameter Grade 5 equipment mounting bolts are overloaded for all directions of shock loading. Bolts of 5/8-inch diameter and of Grade 8 should be used and one additional foundation bolt should be added on each side of the frame structure to reduce the bolt stresses.

Sludge Collection Tank

The same results as those for the Double Process Tank Module apply for the Sludge Collection Tank.

Membrane Recirculation/Wash Pump Module

The scantlings of the structure as given were found to be inadequate for DDAM shock. The frame structure base channels are overstressed for all directions of shock. The worst-case stresses resulted from a Vertical shock. Heavier channels, or the addition of stiffeners between the channel flanges is recommended. Bolt sizing calculations show that the ½-inch diameter Grade 5 equipment mounting bolts are overloaded for all directions of shock loading. Bolts of 5/8-inch diameter and of Grade 8 should be used and one additional foundation bolt should be added on each side of the frame structure to reduce the bolt stresses. The new bolts should be positioned at the location of the base frame cross support.

Typical Vertical Pump Module

The scantlings of the foundation structure as given were found to be adequate for all directions of shock loading. All membrane stresses are less than the allowable value. The ½-inch mounting bolt size was also found to be adequate. Foundation plate stresses associated with mounting bolt bearing, tear-out and pull through were within allowable limits. Typical welds used to attach the foundation to ships' structure will be of sufficient size to transfer imposed shock loads.

Typical Ozone Pump Module

The same results as those for the Typical Vertical Pump Module apply for the Typical Ozone Pump Module.

Typical Pipe Supports

The scantlings of the foundation structure as given were found to be adequate for all directions of shock loading. All membrane stresses are less than the allowable value. The ½-inch mounting bolt size was also found to be adequate. Foundation plat stresses associated with mounting bolt bearing, tear-out and pull through were within allowable limits.

6.1.2 Other Equipment

Several system components including: ozone generator, control and power enclosures, shaker screen and transformer were not analyzed using DDAM.

Ozone Generator

The ozone generator is a commercial unit manufactured by Pacific Ozone, model super SGA24 used on this system mounted into a National Electrical Manufacturers Association (NEMA) IV stainless steel enclosure. Enclosures similar to this have passed Grade B shock without additional modification, but because of the enclosure weight, it is recommended that the bolts be changed from 3/8-inch to ½-inch.

Control and Power Enclosures

The control and power components, like the ozone generator, are housed in stainless steel, NEMA IV enclosures. This type of enclosure has a hinged door with bolt hold downs and four mounting tabs. It is currently used and has successfully passed Grade B shock on other Navy equipment. The mounting tabs which are partially welded to the enclosure are typically not adequate for Grade B shock on any size enclosure. Depending on the size and weight of the enclosure, these tabs can either be modified by fully welding them to the enclosure or on larger, heavier enclosures by replacing the mounting tabs. The control enclosure will be adequate for Grade B shock with fully welded mounting tabs. For the power enclosure, the fully welded mounting tabs are not sufficient. The four mounting tabs must be removed and replaced with two 2-inch wide by ¼-inch thick stainless steel bars with intermittent filet welds. The mounting bolts should be a minimum of 7/16-inch for this enclosure.

Shaker Screen

The shaker screen is commercial equipment supplied by SWECO, model LS18S33. It is basically 18 inches in diameter with a circular mounting base with springs to allow shaker movement. DDAM analysis is not recommended for this component. It should be shock tested or an enclosure around the screen should be used on shipboard units to meet Grade B shock requirements.

Transformer

The transformer is a commercial unit that has not been designed for Navy shock. This transformer should be replaced with an equivalent that has been qualified for Grade B shock for shipboard use.

6.2 Laboratory Demonstration

6.2.1 System Installation

NSWCCD purchased a Navalis Orion™ Model 5 Advanced Wastewater Treatment System in July 2008. Figure 13 shows the purchased Navalis Orion™ prior to delivery to Carderock.



Figure 13. Photo of the Navalis Orion™ Model 5 Advanced Oxidation Wastewater Treatment System Rear View

The Navalis Orion™ was delivered to Carderock Non-oily Wastewater laboratory on 23 February 2009. The unit was mounted on a steel skid for delivery and remained mounted on the skid for the evaluation. The installation included placing the unit in the designated area in the laboratory, connecting the influent, effluent, sludge, and vent lines to the appropriate points on the system, supplying air to the inlet connection point, and supplying 440-VAC power to the control enclosure. All pipe fittings were stainless steel piping with flanged connections, which needed adapters to mate to the existing laboratory equipment. On 24 February 2009, a puddle was noticed under the Moyno drain/SDT pump and it was determined that the inlet casing was cracked. Navalis Environmental Systems immediately ordered the part and it was replaced the next day. Navalis Environmental Systems and NAVSEA Carderock personnel completed the installation on 26 February 2009.

6.2.2 Test Preparation

6.2.2.1 Commissioning of the System

As a part of the delivery order, Navalis representatives visited Carderock to set up and operate the system as designed. The commissioning was conducted in two sessions due to the delayed completion of the LWFS modifications.

The initial set up was performed on 24 February – 12 March 2009 by Navalis representatives. The initial set up included installation of the 200-mesh screen, the UV bulb, and tubular filter sleeves. Navalis representatives also verified that all the spare parts were delivered. In addition to the requested spare parts, Navalis provided several other items that may be needed in the future. Navalis representatives inspected the system and each connection to verify nothing else was damaged during the shipment or installation. They also labeled the components, valves, and pipe direction. All of the pumps were tested to verify they were operating in the correct direction. The system was tested using potable water to ensure proper operation of each component. Several adjustments were conducted during the operation of the system. A more detailed account of the installation/commissioning events is provided in the Navalis report in Appendix F.

After completion of the setup and departure of Navalis representatives, NSWCCD personnel determined the Reactor air/ozone dissolving pump was not correctly aligned. Navalis contracted the pump manufacturer, Rogue Pumps, to repair the rubber coupling and aligned all three Rogue pumps. The finalization of the commissioning included the following: chemical preparation and dosing calibrations, operation of the system using combined BW/GW to set the proper chemical dosing quantities, and final adjustments of all of the hand valves, programming, and pumps. The Navalis representatives returned to finalize commissioning of the system on 25-27 March 2009. NSWCCD provided a dedicated hot water heater to flush the mesh screen. Navalis representatives confirmed that the system was operating as designed.

6.2.2.2 Laboratory Checkout

Laboratory checkout was conducted 31 March – 6 May 2009 using combined graywater and blackwater (Category B wastewater). NSWCCD began operating the system on 31 March 2009, a few days following the commissioning of the unit, to familiarize the operators with powering up and operating the system. Five hours after operating the system with combined blackwater and graywater, NSWCCD operators noticed the mesh screen was clogged. The system had only processed 800 gallons of combined wastewater in which 200 gallons was sludge. As a result, the frequency of hot water spray was increased from 15 seconds per hour to 15 seconds every 15 seconds. Three hours later the mesh screen clogged again. Operators removed the screen to clean as recommended by Navalis representative. Pictured below in Figure 14 are photos of before and after the screen was cleaned by NSWCCD personnel.



Figure 14: Photos of the Clogged 200-mesh screen (left) and the Cleaned 200-mesh screen (right)

There was only a 4" diameter clearing in the center for the wastewater to flow through the screen. After further examination of the clogged screen, it was observed that the spray pattern on the screen is just four rounded rectangles at different angles (shown by the red arrows). Operators replaced the screen within 30 minutes and continued processing wastewater. After 11 processing hours, the system processed 1400 gallons of wastewater and generated 500 gallons of sludge.

The Orion™ system is rated to process 7,200 gallons of wastewater per day at 5 gallons/minute. After 24 hours of processing the combined wastewater, the system only processed 3,250 gallons of wastewater from the feed tank, but processed 6,700 gallons of wastewater from the AET, generated 400 gallons of sludge. In order to compensate for the difference in processing volume, Navalis recommended the following changes:

- exchange the 200-mesh screen with the 94-mesh screen
- replace the 5 µm tube filters socks with new filters socks
- set feed flow rate to the system at 6.5 gpm
- flush the shaker screen for 5 seconds every 10 minutes
- change the tube filter settings to run 150 seconds and backwash for 2 seconds
- set the membrane reject target flow to 0.44 gpm and the membrane product target flow to 5.28 gpm
- change the dump time of the hydraulic separator to 120 seconds.

NSWCCD personnel made all of these changes on 20 April 2009.

On 21 April 2009, the system shutdown due to alarms from high ambient ozone concentration, sludge decant tank high, and membrane wash tank high, and then NAVSEA Carderock called Navalis Environmental to troubleshoot the system. On 22 April, a Navalis representative arrived to investigate the problem and learned that FCV 205B (feed valve to the filter sock #1) was not physically opening even though the program indicated it was open and replaced the 5 µm tube filters with the 20 µm filters socks. In addition, the Navalis representative found a loose wire to the solenoid for FCV 205B, found a loose air hose to the valve, fixed the problem, and checked all of the valves for functional operation. After the inspection, all valves were operable and indicating properly on the display. After starting the system in automatic mode, a program glitch

was detected and Navalis programmers were alerted to make the changes to the program. On 23 April, the Navalis representative uploaded the new program and made an executive decision to replace the 94-mesh screen with the 74-mesh screen which was adequate to handle the solids concentration and flow rate.

Meanwhile, the Navalis representative examined the spray pattern on the mesh screen and learned that SWECO (shaker screen manufacturer) provided the wrong spray nozzles. The current nozzles only spray straight down on the screen, whereas the requested nozzles provide a conical spray pattern on the screen. The four conical spray nozzles would cover circular areas and should overlap each other. The correct nozzles were ordered on 24 April and then installed on 27 April 2009.

From 27 April – 6 May 2009, Navalis representatives conducted system debugging and program modifications. Navalis representatives and NSWCCD operators started the system and continued the debugging process. On 6 May, the tube filter feed pump was replaced with a 2 HP pump, a new motor overload was installed and program modification were completed to increase the flow/pressure through the tube filters. NSWCCD operators continued the laboratory checkout of the system through 13 May 2009. All system operations were then functioning as expected with the knowledge that routine maintenance was required on the shaker screen and possible adjustments of the valves for the Sludge ozone dissolving pump.

In summary, the following changes were made to the system prior to Phase 1 testing:

- Exchange the 200-mesh screen with the 94-mesh screen and then a 74-mesh screen
- Replace the 5 µm tube filters socks with new filters socks
- Set the feed flow rate to the system at 6.5 gpm
- Set the flush frequency to the shaker screen for 5 seconds every 10 minutes
- Change the tube filter settings to run 150 seconds and then backwash for 2 seconds
- Set the membrane reject target flow to 0.44 gpm and the membrane product target flow to 5.28 gpm
- Change the dump time of the hydraulic separator to 120 seconds.
- Replaced the Sludge discharge pump casing that was cracked during delivery
- Uploaded four different programming modifications to the PLC
- Replaced the four straight spray nozzles with conical spray nozzles in the covered shaker
- Replaced the Gould 1 HP filter charge pump with a 2 HP pump of the same make

During the checkout, the system operated for 91 hours and generated approximately 3,406 gallons of sludge. The analytical results showed that only TSS and FC met the effluent threshold, and COD and BOD₅ values were above the threshold. Samples were collected on 2 April 2009 to show the progressive improvement in clarity as wastewater is treated in the process and are pictured in Figure 15. Analytical results are presented in Table 7.

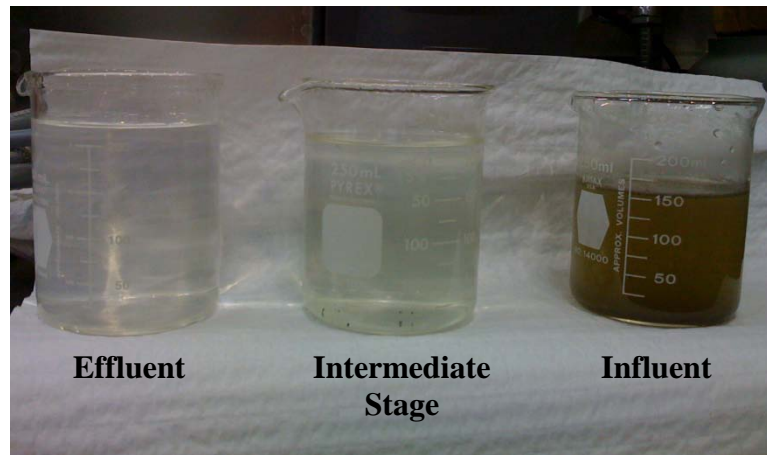

Figure 15: Photos of Samples Collected During Checkout.

During the checkout, the BOD₅ and COD effluent quality threshold were only met three times of the nine effluent samples collected. The influent concentrations were within the range throughout the system checkout. Table 7 is a summary and comparison of the results to the performance specification and IMO MEPC.159(55) regulations.

Table 7. Analytical Results for Checkout

Category B	BOD₅ (mg/L)	COD (mg/L)	TSS (mg/L)	O/G (mg/L)	FC (cfu/100 mL)
Influent Average (9 samples)	909	1,733	502	67	
Test Influent Requirement	530 – 1,300		700 – 2,400	100 – 220	
Effluent Averages (9 samples)	30.6	125.7	2.88		3
Effluent Ranges	9 – 72	69 – 160	2 – 6		3
USCG Effluent Limit			≤ 150		≤ 200
MARPOL Effluent Limit	≤ 25	≤ 125	≤ 35		≤ 100

6.2.3 Phase 1 Test Results

This section of the report discusses the results of the Phase 1 testing of the Navalys Orion™ MSD, including the Examinations, Analyses, Pre-Operational Tests, and Operational Tests. The test numbers in the tables below correspond to those in the test plan.

6.2.3.1 Examinations

The first part of Phase 1 consisted of visual and dimensional examinations of the test system. During the examination of the Orion™ system, measurements and inspections were conducted and recorded in Tables 8 and 9.

As discussed in the test plan, since this equipment is not associated with a ship procurement, the footprint parameters were measured and recorded, but no “pass/fail” criteria was applied. The physical size of the test system was not compared to the system size allotment of a specific ship class. The capacity and dimensions of the tanks are listed in the Table below.

Table 8. Navalys Orion™ Tank Size and Capacity

Tank	Dimension (inches)	Capacity
Shaker Decant	30 L x 30 W x 36 H	120 gallons (465 liters)
Hydraulic Separator	60 H x 24 Dia	100 gallons (378 liters)
Intermediate	30 L x 30 W x 36 H	120 gallons (465 liters)
Membrane Feed	30 L x 30 W x 36 H	120 gallons (465 liters)
Membrane Wash	30 L x 30 W x 36 H	120 gallons (465 liters)
Reactor	30 L x 30 W x 54 H	200 gallons (757 liters)
Finish	30 L x 30 W x 36 H	120 gallons (465 liters)
Sludge Reduction	30 L x 30 W x 48 H	185 gallons (700 liters)
Sludge Decant	30 L x 30 W x 36 H	120 gallons (465 liters)

L = length W = width H = height Dia = diameter

Examinations of the system revealed that the system is modular. This system did not have any backflow preventers to mitigate flow back into the supply or from discharge interfaces until after the laboratory check out. The laboratory system had the benefit of upward flow into the system to prevent backflow into the source tank or lab space and a check valve was installed on the effluent line to prevent siphoning of the finish (effluent) tank. It was also noted that there was commonality of pumps on the system. Navalys Environmental Systems used pump commonality to reduce the number of spares or redundant pumps needed for the system. All other criteria for the examination of the system were met.

Table 9. Phase 1 Examinations Summary

Test	Description	Success Criteria and Result (Y/N)	Y/N	Comments
1-1	Physical size	Not applicable. All installed equipment including access envelopes shall fit within the reserved space and geometry of the intended ship		L = 183" (24'6") W = 111" (9'3") H = 90" (7'6") Access Envelope: three additional feet on all sides of the system.
1-2	Modularity	All replaceable parts will fit through standard U. S. Navy doors and hatches	Y	All of the system components could fit through the hatches, except the tanks need to be fabricated in the space
1-3	Backflow Preventer	System has the capability of preventing back flow of wastewater through the laboratory supply and discharge interfaces	Y	There were not any backflow preventers on the system prior to laboratory checkout, but were installed prior to the performance evaluation.
1-4	Air escapes	System has adequate vents or means to prevent overpressurization or accumulation of gases	Y	All tanks were vented via connection to the laboratory vent lines.
1-5	Accessibility	Applicable system components are accessible for maintenance and replacement; tank access as described in Test 1-5 of the test plan	Y	All components were accessible from the front or back of the system, except the internal components in the tanks. These components were accessible from the bolted down hatch on each tank.
1-6	Sampling Ports	System includes sufficient sampling points.	Y	Sampling ports were installed on the inlet, flocculation, outlet, and sludge tanks.
1-7	Redundant Pumps	System has 100% redundancy for all pumps that are critical to the successful treatment of the wastewater	N	Navalis used common pumps instead of redundancy to reduce the number of spares needed for the system.
1-8	Human factors	All man-machine interfaces are suitable for fifth through ninety-fifth percentile anthropometric data per ASTM F 1166	Y	The only concern noted was climbing on top of the system to conduct maintenance on the chemicals, internal components of the tanks, and shaker screen

6.2.3.2 Analyses

The next part of the Phase 1 testing of the MSD system was an analysis for tank volume, consumable volume and safety. The analysis was completed based on operation manuals, drawings, and the hardware received from Navalis Environmental Systems as well as via discussions with their personnel. The information was recorded in Table 10. No extra observations were added to the original test plan based on inspection of these documents. The Operation, Maintenance and Installation Manual is located in Appendix G.

Tests 1-10, 1-11, and 1-12 results were calculated based on the laboratory system. However, in a normal procurement this measurement would be compared to the blackwater and graywater treatment system size and weight allotments for a specific ship class. Results of this comparison would be used to determine whether the system meets the requirements. All criteria for the analysis of the system were met. Tank volumes were provided for full capacity, but not the working capacity.

In test 1-14, all environmental, safety and health risks were adequately addressed. The confirmation e-mails are included in Appendix H.

Table 10. Phase 1 Analysis Summary

Test	Description	Success Criteria and Result (Y/N)	Y/N	Comments
1-9	Material	Material conforms to requirements	Y	Stainless Steel
1-10	Weight	Not applicable. Weight shall not exceed the weight budget of the intended ship		8,500 lbs Dry 10,000 lbs Wet
1-11	Tank volume	Not applicable. Tank volume shall conform to the available tank volume provided by the intended ship for each wastewater type		<i>See Table 9 above.</i>
1-12	Consumables volume	Not applicable. The consumables volume shall not exceed the reserved storage space of the intended ship		30 gallons MarFloc 7825 <i>(adequate for entire test)</i>
1-13	Sensors	Sensors are calibrated and conform to requirements	Y	<i>See Navalis Operation Manual</i>
1-14	Safety	System presents no safety/health hazards to personnel while operating or secured	Y	<i>See Environmental Safety and Health Review</i>

6.2.3.3 Pre-Operational Tests

The third part of Phase 1 included a hydrostatic test and tests of the control system and operational modes. All tests requiring fluid transfers were conducted using potable water. The results were recorded in Table 11.

Test 1-15 for hydrostatic integrity was not performed during the laboratory evaluation. The manufacturer performed this test prior to delivery and NSWCCD has not obtained the documentation. The system provided monitoring and control (Test 1-17) programming, there was no remote E-stop control, but did have an E-STOP button to pass this criterion. The system also passed Test 1-18, audible alerts and alarms. As for Test 1-19, visual alerts and alarms, the system has lights illuminating on the displayed process flow diagram on the control panel to indicate malfunctions of various components on the system. All other criteria for the pre-operational test were met.

Table 11. Phase 1 Pre-operational Tests

Test	Description	Success Criteria and Result (Y/N)	Y/N	Comments
1-15	Hydrostatic integrity	System is capable of withstanding hydro pressure of 50 psi or 150% of design pressure, whichever is greater, with no leaks or deformation		<i>Never received results, but Navalis stated that the system passed the test.</i>
1-16	Operational modes	System has the following operating modes, or equivalent: start-up (automatic); standby; process (automatic); manual (for maintenance, etc); and shutdown (automatic)	Y	AUTO – Automatic start-up, process, standby, and shutdown OFF – Standby/Off MANUAL – Manual (programmed button)
1-17	Monitoring and control	System self-monitors in all modes; control system includes PLC (or equivalent) and display; system includes local and remote E-stops; emergency shutdowns are safe and controlled	N	System has safe guards programmed into the control system in each mode. System does not have a remote E-stop, but could be programmed upon request.
1-18	Audible alerts and alarms	Local and remote audible alerts and alarms function properly	N	System does have audible alarms or alerts. Manufacturer states audible alarms could be installed upon request.
1-19	Visual alerts and alarms	Local and remote visual alerts and alarms function properly	N	System has the P&ID displayed on the control panel with lights to indicate which components are or are not working properly and the PLC displays alerts and alarms.

6.2.3.4 Operational Tests

The fourth part of Phase 1 included tests of the system’s ability to meet the specification performance requirements; that is, its ability to produce an effluent that is acceptable for overboard discharge while operating at the design rate. The tests were conducted using the Category B test mixture (BW/GW) at an average daily flow rate of 4,023 gpd. The results are recorded in Table 12.

Table 12. Phase 1 Operational Tests

Test	Description	Success Criteria and Result (Y/N)	Y/N	Comments
1-20	Processing (15 days)	System meets all effluent discharge requirements at the following processing rates: - 6,600 gpd (12 days) - 7,200 gpd (3 days)	N	System processed average daily flow rate of 4,023 gpd over 15 days and maximum flow rate of 5,134 gpd
1-21	Waste solids holding capacity	Not applicable. (Record results only.)		Sludge was automatically discharged as needed. Averaged ~600 gpd
1-22	Safety	System presents no safety/health hazards during operation; no dangerous gases or liquids are released.	Y	Handling and storage of chemicals required for operation, but no hydrogen sulfide or ozone gases were detected from the system.
1-23	Maximum temperature and pressure	During operation, temperature never exceeds 250°F coincident with pressure above 15 psig.	Y	Average operating temperature was 35°C (95°F) and pressure inside pressure vessel was 1 bar (14.5 psig). Discharge pressures were ~3.6 bar (52.2 psi)
1-24	Data acquisition/retrieval	System can store and retrieve appropriate data.	Y	User friendly equipment and software used for data logging
1-25	System drain	System drains completely.	Y	Completed in 90 minutes.
1-26	Tank cleaning	Effluent and surge tanks can be flushed with treated effluent or seawater; system can discharge the flush water.	Y	Operators used potable water to flush tanks at the end of Phase 1 testing.

The operational test was conducted 15 May – June 2009. The system was scheduled to process automatically in a continuous mode (0600 hours on Monday through 0600 hours on Saturday), with no operation on holidays. The system operated for 314 hours over a 15-day period and processed with BW/GW throughout this period. Operators were in attendance for ten hours per day. Operators manually recorded processing data, such as flow rates, cumulative volume, and sludge generation, while other data was recorded on the data logger. In addition, operators noted alarm occurrences, chemical additions, operator interventions, maintenance events, and pertinent changes to the operating conditions. The Phase 1 maintenance log and analytical data are included in Appendix I.

Cold Start

The cold start was conducted at the start of the test. All of the Navalix Orion™ tanks were filled to the 50% level with potable water, except the reactor was filled to the 100% level. On May

14th, the cold start was conducted for 12 hours and operators collected samples every four hours. The system processed 2,647 gallons of BW/GW and produced 2,266 gallons of effluent. No sludge was generated during this period. The influent contaminant levels were above the specified range listed in Table 1 throughout the test. The system did not meet the effluent quality threshold for BOD₅ and COD, but did meet the TSS and FC thresholds within the 12-hour processing period. The results are shown in Tables 13.

Table 13. Phase 1 BW/GW Cold Start Analytical Results

Category B	BOD₅ (mg/L)	COD (mg/L)	TSS (mg/L)	FC (cfu/100 mL)	O/G (mg/L)
Influent Average (5 samples)	1,640	3,160	660		226
Test Influent Requirement	530 – 1,300		700 – 2,400		100 – 220
Effluent Averages (5 samples)	132	302	2	1	
Effluent Ranges			≤ 150	≤ 200	
USCG Effluent Limit	≤ 25	≤ 125	≤ 35	≤ 100	

Processing

Based on the operating schedule, Phase 1 was designed to process at least 99,000 gallons of BW/GW, while only generating 1,500 gallons of sludge (1.5% of the processed volume). Instead, the system only processed 60,340 gallons of wastewater, while generating 10,480 gallons of sludge. This is equivalent to about 4,000 gallons of processed wastewater per day and generated 600% more sludge than expected. The system also required 877 gallons of potable water to flush the mesh screen. Table 14 summarizes these measurements.

Table 14. Phase 1 BW/GW Processing Summary for 15 May – 23 June 2009

Wastestream	Volume Processed (gallons)	Goal (gallons)	Actual (%)	Goal (%)
Blackwater	7,000	11,200	12	10
Graywater	53,600	101,000	88	90
Total Mixture	60,600	112,200		
Sludge	10,480 (17% of processed volume)	3,021 (Navalis estimated 1.5% of processed volume)		
Flush Water (potable water usage)	877	unknown		

The first objective of this part of the evaluation was to process wastewater within the influent concentration ranges listed in Table 1. The results from Martel Laboratories show that the average parameter values of the influent were above the required range for BOD₅ and O/G parameters, but the TSS average value was within the desired range. Table 15 summarizes the analytical results of the influent wastewater compared to the performance specification.

Table 15. Phase 1 Influent Composition

Wastewater Parameter	Performance Specification 40-sample Average Range (mg/L)	Actual 40-Sample Average (mg/L)
BOD ₅	530 – 1,300	1,404
COD		2,669
TSS	700 – 2,400	1,478
O/G	100 – 220	205

During testing, the sludge tank was drained automatically when the sludge tank reached capacity (periodically throughout each day). Also, the mesh screen was manually cleaned twice using an all-purpose spray detergent and hot water during recommended cleaning until the 74-mesh screen was installed and the spray frequency was changed.

Another objective was to achieve the designed processing rates set at 6,600 gpd for the evaluation. The actual processing rate averaged 4,023 gpd which was calculated using the flow data from the LWFS. The processing rate was not achieved throughout the evaluation. The maximum processing rate was 5,134 gpd. The system was not able to meet the design processing rate due to the timed-programming tank transfers, solids concentrations, and residence time in the sludge reduction tanks.

In addition, the system lacks automatic adjustments for the sludge transfer to occur at the design pressure. A consistent pressure would allow a faster transfer of sludge to the sludge tank. Operators observed that the system processed at a slower rate (~11 gph), injected chemicals at a higher rate, and generated a lower sludge concentration than expected.

A large impairment of the system operation was due to the Solids Separation Zone. The reasons for reduced throughput were as follows:

- Shaker Screen Blinding – The screen blinding diverted a high volume of influent directly to the sludge reduction system and to the AET for recycle.
- Time-Based Phase Separation at the Hydraulic Separator – More dilute volumes of sludge from the hydraulic separator were sent to the Sludge Collection and Reduction tank. The system did not actually sense a phase change to stop the phase transfer from the hydraulic separator. More liquid entered the Sludge Collection and Reduction tank instead of being processed through the system.

- High Frequency Tubular Filter Socks Backwash Cycle – A significant fraction of treated Finishing Tank water was sent back through the system as backwash.
- Time-Based Phase Separation at the SDT –The time-based phase separation at the SDT was a contributor to the high sludge generation rate. More dilute volumes of sludge from the SDT were sent to the sludge storage tank increasing the volume and sludge generation rate.

The sludge generation was greater than expected with an average of 699 gpd. The system discharged sludge based on tank level and settling time, whereas the system should have had some type of phase sensor or turbidity probe installed on the sludge transfer piping to indicate when the actual sludge was transferred to the holding tank.

Phase 1 Sampling and Analysis Results

The services of a statistician, Mr. Kevin Burns of Science Applications International Corporation, were provided by NAVSEA. The statistician provided recommendations on sample size to assure statistical significance and then analyzed data from the testing to validate statistical significance, determine trends and provide conclusions on the test results. This statistician has provided his services for laboratory, as well as shipboard tests, for many years and is familiar with the treatment processes, wastewater characteristics, and laboratory and shipboard operations. The statistician also provided support for the development of the performance specification requirements. Data for each parameter were used to calculate geometric means, arithmetic means, and variances to determine statistical significance of differences and fit data for correlations.

A statistical analysis was conducted on all of the data to determine if any patterns and correlations exist between the influent and effluent concentrations and whether the system was able to produce effluent quality as specified in the performance specification. A detailed discussion of these results is located in Technical Note No.10-167-01, found in Appendix J. Analytical results are summarized in Table 16.

Table 16. Phase 1 Sampling Results

Category B	BOD₅ (mg/L)	COD (mg/L)	TSS (mg/L)	FC (cfu/100 mL)	O/G (mg/L)
Influent Average (40 samples)	1,404	2,669	1,478		205
Test Influent Requirement	530 – 1,300		700 – 2,400		100 – 220
Effluent Averages (40 samples)	60	145	1.6	5.6	
Effluent Ranges			≤ 150	≤ 200	
USCG Effluent Limit	≤ 25	≤ 125	≤ 35	≤ 100	

The influent composition specified by the performance specification was met for TSS and O/G, but exceeded the BOD₅ range. Analysis showed that effluent BOD₅ correlated with influent

BOD₅ levels. However, the effluent geometric mean for BOD₅ was more than double the MARPOL limit, and processing somewhat lower influent BOD₅ concentrations would not likely result in values meeting the MARPOL limit. O/G analysis was not performed for the effluent stream. Figures 19 - 23 graphically show the influent and effluent analytical results for BOD₅, COD, TSS, FC, and O/G for Phase 1.

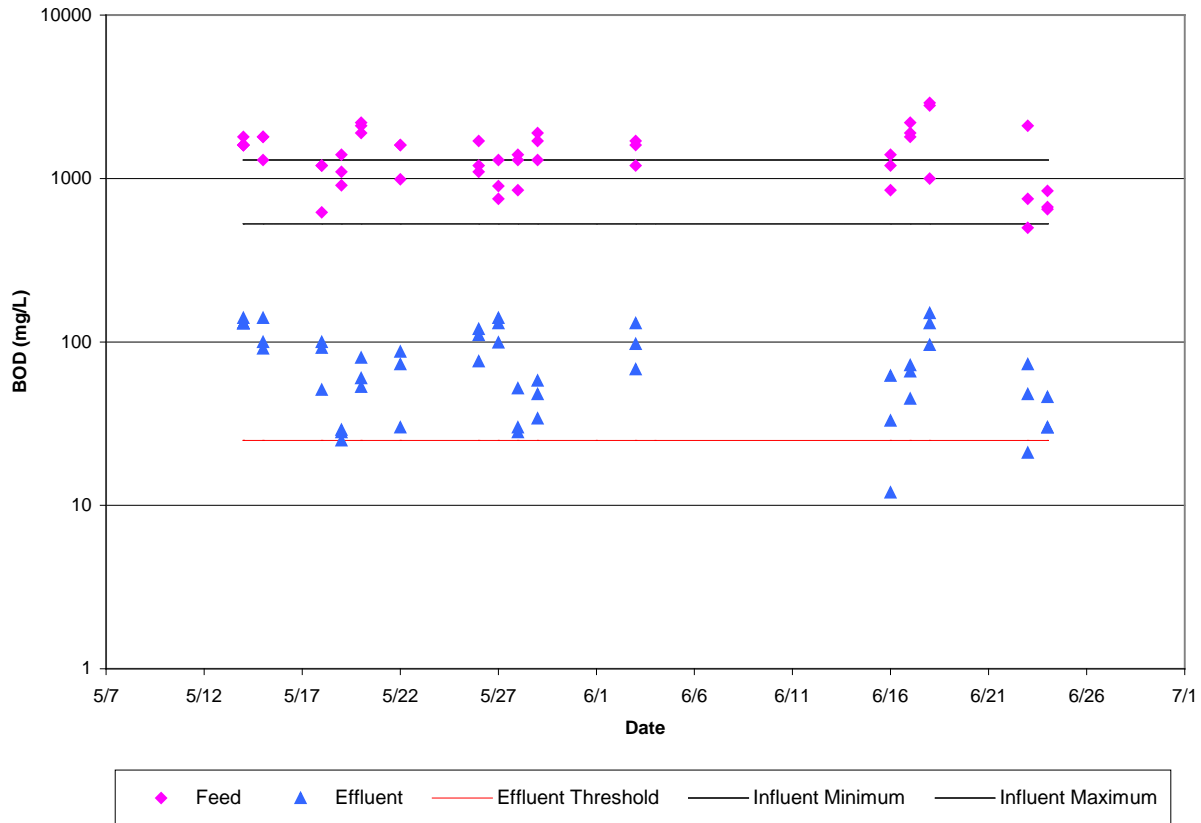

Figure 16. Graph of Analytical Results for BOD₅ for Phase 1

Figure 16 shows that a third of the influent BOD₅ concentrations exceeded the influent range during Phase 1 testing and only three of the effluent concentrations were below the threshold. The performance specification influent BOD₅ range is 530 – 1,300 mg/L. According to Technical Note No. 10-167-01, the average influent BOD₅ concentration was close enough to the allowable range. Figure 1 in Appendix E shows the lognormal fit model between the influent and effluent concentrations. In fact, the data points fall along a line so there were no clear outliers.

Figure 17 shows that about half of the effluent COD concentrations were below the effluent threshold throughout Phase 1 testing. The highest effluent concentration obtained during Phase 1 was 346 mg/L. According to Technical Note No. 10-167-01, an effluent COD concentration would be greater if the influent COD concentration is high. The effluent geometric mean for COD was about 25% higher the MARPOL limit. Therefore, it seems that the system may have met the standard with somewhat lower feed concentrations.

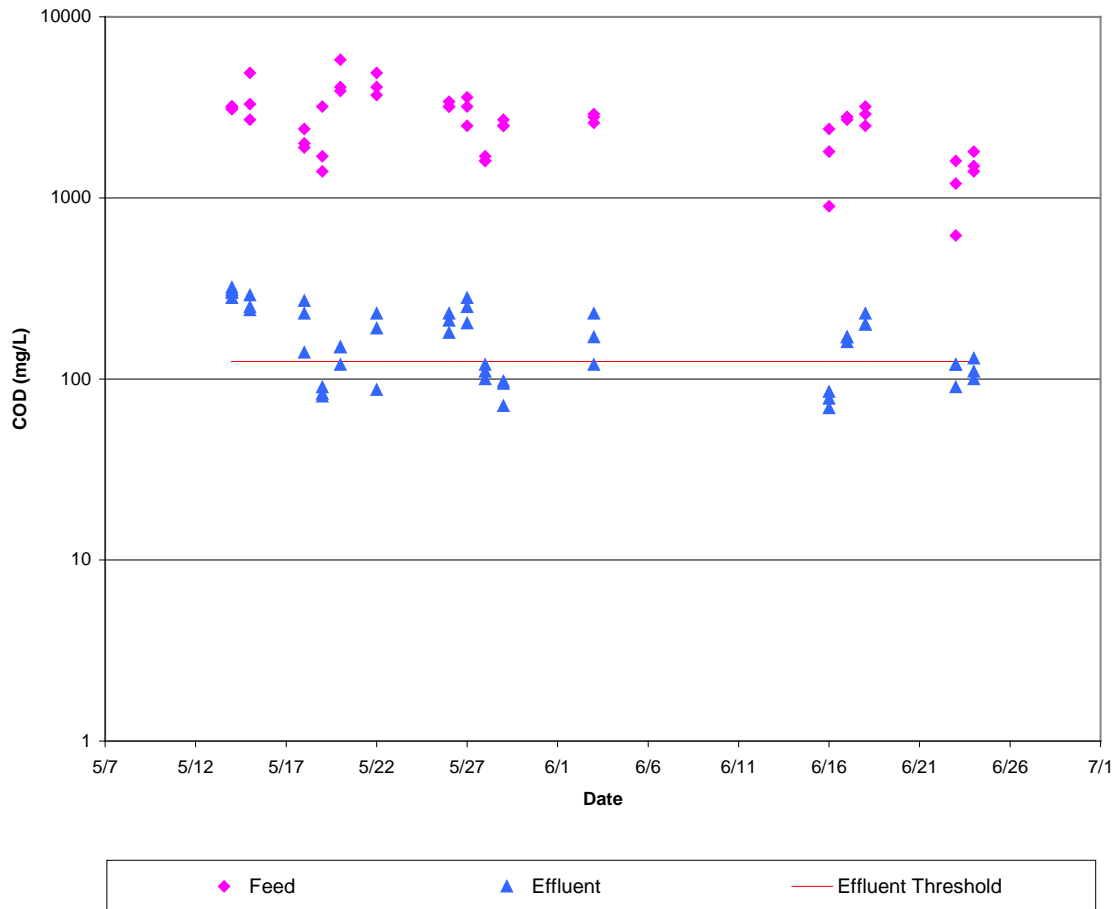

Figure 17. Graph of Analytical Results for COD for Phase 1

Figure 18 shows that all of the effluent TSS concentrations were well below the effluent threshold throughout Phase 1 testing. The highest effluent concentration obtained during Phase 1 was 7 mg/L. According to the Technical Note No. 06-5605-151-013, an effluent TSS concentration was 1.6 mg/L. The system had no problem removing the suspended solids from the wastewater.

The high BOD₅ and COD effluent values are an indication that the ozone and UV advanced oxidation reaction did not remove the organic contents sufficiently. The fact that TSS is able to be reduced adequately shows that precipitated solids are not the source of organics. However, if dissolved solids are not removed, they may be the source of the BOD₅.

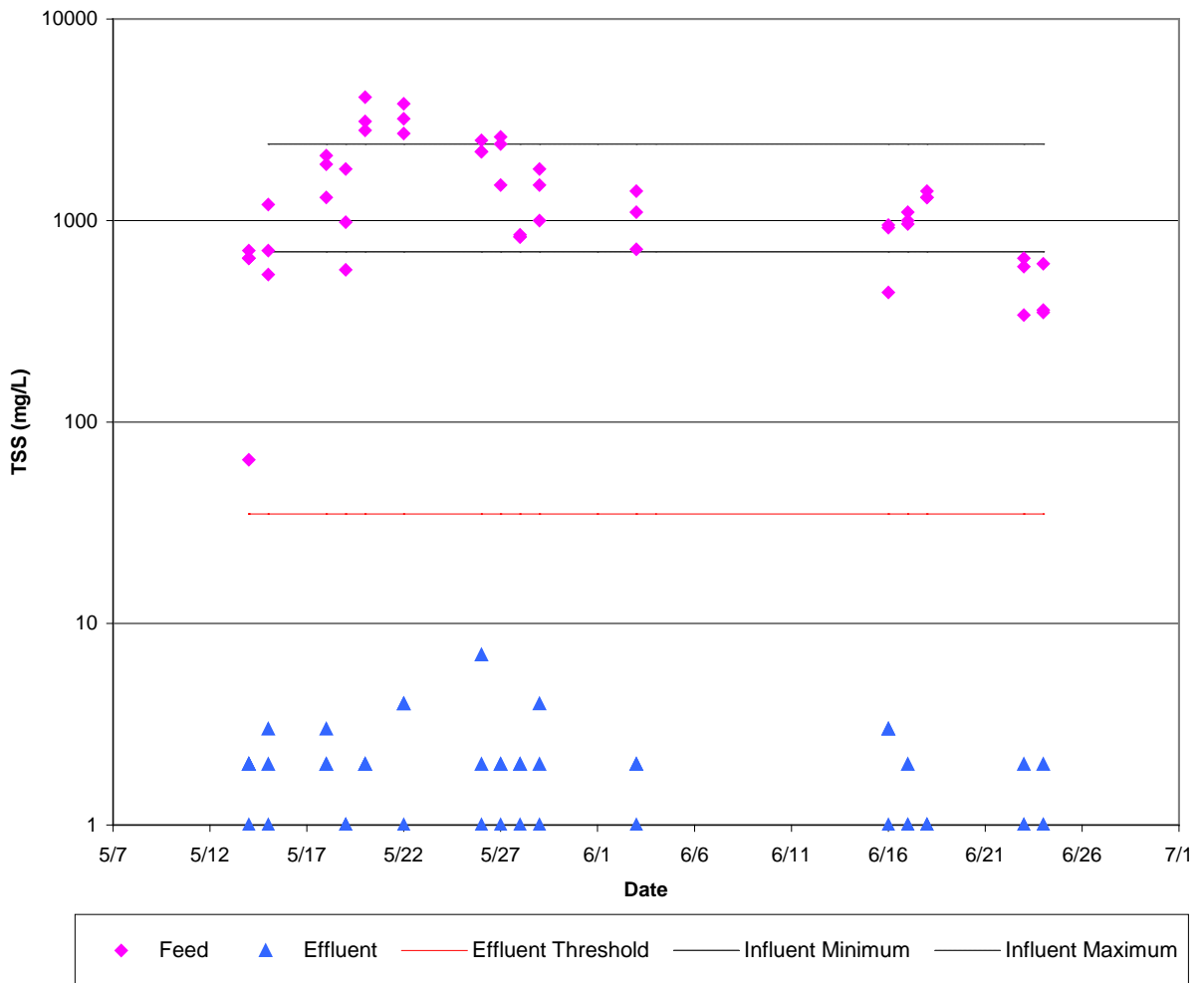

Figure 18. Graph of Analytical Results for TSS for Phase 1

Figure 19 shows that the effluent FC concentrations were consistently lower than the effluent FC threshold. The influent FC concentrations were not measured during this test. However, prior laboratory evaluations show that the initial FC concentrations were in the order of 1×10^6 cfu/100mL. The magnitude of the FC content of BW and GW is extremely large, there is no concern that an influent wastewater will have an insufficient level and not simulate Navy waste.

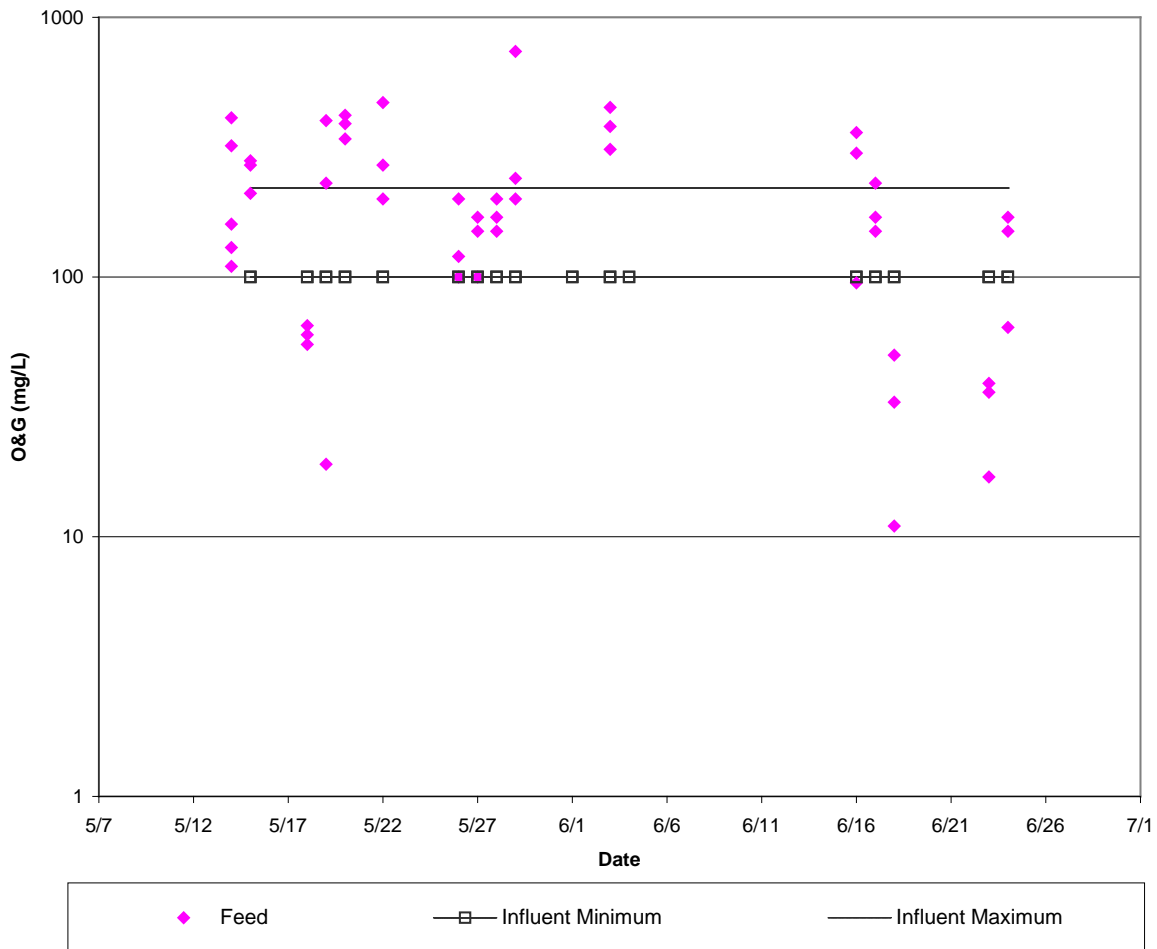

Figure 20. Graph of Analytical Results for O/G for Phase 1

In addition, the effluent samples were analyzed for pH using an Oakton Instruments pH Testr. pH is newly regulated by MARPOL and effluent discharge must range between 6 and 8.5. This data was collected and analyzed in-house. The pH measurement ranged 6.5 – 7.4 throughout the evaluation. Therefore, the pH effluent requirement was met during Phase 1.

Sludge samples were collected three times a day. Samples were analyzed for TSS by Martel Laboratories. The average TSS measurement was 21,547 mg/L, which is similar to previously tested marine sanitation device TSS values.

Membrane Recovery Analysis

As stated in the test plan, the membrane recovery rate is the ratio of the permeate flow to the feed flow entering the membrane.

$$\text{Percent Membrane Recovery} = \frac{\text{Permeate Flow Rate of the Membrane}}{\text{Feed Flow Rate to the Membrane}} * 100$$

These parameters were measured with the auto log flow rates and using daily averages. Using the data which was recorded every ten minutes and the total processing hours, the average permeate flow to the reactor was 1.205 gallons per minute (0.004 m³/min) and the average feed flow to the membrane was 1.753 gallons per minute (0.007 m³/min). Therefore, the above calculation results in a 69% recovery.

Solids Holding and Sludge Generation

The sludge was composed from two sources; screened solids from the shaker screen and floating bed of solids (floc) from the hydraulic separator. The system automatically transferred the sludge from the shaker screen to the sludge decant tank (SDT) and the floc to the sludge reduction tank (SRT). The solids from the Hydraulic Separator were directed to the SRT at an expected dry solids weight of about 2.5%. These solids were treated with ozone for about four hours by continuously recirculating the sludge and introducing ozone. This process was to oxidize the organic material into carbon dioxide and water and reduce sludge volume. At periodic intervals, a preset amount of the reacted sludge was transferred from the SRT to the SDT. Both tanks were vented through the ozone destruct unit. Since the operators adjusted valves to increase or decrease the pressure in the piping to allow transfer, the time for the transfer was inconsistent causing residence time to vary in the SRT and SDT. Although the sludge was not completely oxidized, there was very little odor released from the collected samples.

In the SDT, the reacted material was allowed to rest in a quiescent state where clarification by gravity occurred. The solids settled to the bottom of the tank leaving a clarified middle section with a small amount of floating material on top. After a set amount of time, the clarified liquor was pumped to the AET, and the concentrated sludge was then transferred to the sludge holding tank.

The actual sludge generation was 10,480 gallons of sludge, which resulted in 17.4% of the process volume. The sludge generation was greater than expected. According to Navalis, the sludge generation is dependent upon the influent O/G content because it may clog the screen and reduce the passable surface area of the screen. Based on observations during this test, excessive sludge generation was also due to the time-based phase separations in the Hydraulic Separator and the SDT vice using instrumentation to sense the sludge phase and only transferring sludge when detected.

Sludge Reduction Treatment Analysis

The sludge reduction analysis was not conducted because of all the problems operators were having with adjusting the pressures of the sludge ozone pump. Operators could not determine if the designed quantity of ozone was entering the system during normal operation.

Maintenance

On a daily basis, the following maintenance was performed by the operator: checked or cleaned the shaker screen of debris, checked the chemical dosing equipment every hour because there were no alarms to indicate the chemicals were not entering the system, monitored the chemical tank levels, and adjusted the transfer valves from the SRT or SDT. The operation manual states the importance of the dosage being correct for a working process; therefore the operators monitored the chemical feed line to the flocculator. The chemical tank was refilled everyday. Additional maintenance was conducted as Navalis recommended. The estimated time required for maintenance was 3 hours per day. Navalis' recommended maintenance and service intervals are provided in the operation, maintenance and installation manual located in Appendix G.

Phase 1 Implementation Issues

- The Shaker Screen mesh was too tight. A 200-mesh and 94-mesh screens were tested. These screens clogged and prevented the raw wastewater from passing through the filter. Instead, the influent transferred to the SDT, reducing the throughput and increasing the volume of recycled to the AET. A 10-mesh screen allowed the solids to pass and clog the tube filters. A 74-mesh screen was finally decided to be the best screen and was used during the evaluation. Navalis claimed that O/G clogged the openings, but the concentration was with the specifications provided to Navalis during the checkout phase.
- The Shaker screen may need weights added to improve the movement of the solids to the decant tank.
- Incorrect spray nozzles were installed in the Shaker Screen. Very little area was sprayed and did not displace the solids from the screen. The corrected nozzles were installed
- The 5-micron tube filters were replaced with 20-micron tube filters.
- The Rogue pump suction must be under vacuum to allow the air/ozone to be injected into the stream. Several adjustments were made to the suction and discharge valves connected to the ozone dissolving pump for the sludge tank. The pressure in the piping changed as the sludge level reduced and/or thickened.
- The timing of the phase separation transfers was adjusted based on a thicker than expected sludge layer in the Hydraulic Separator.
- NSWCCD conducted a quality check of the system and program and found many glitches and faults with both the program and components.

- There was no confirmation of the amount of dissolved ozone entering the reactor to reduce the BOD₅ and COD. Navalis used a larger dissolved pump on its prototype.
- The effluent in the Finishing Tank was used to backwash the tubular filter socks, which reduced from the effluent volume being discharged.
- The UV unit was not always illuminated as indicated on the display. Water entered the black casings that covered the wires and wiper motor. A UV high warning followed by a UV off alarm displayed on the screen. The operator was required to drain the water from the casings, and the UV light would illuminate.
- Dry air for the ozone generation was not specified.
- The daily sludge generation varied due to low or high pressure on the transfer line of the ozone dissolving sludge pump. The transfer of sludge from the SRT to the SDT was affected.
- Heavy solids passed through the hydraulic separator and clogged the filter socks.
- The membrane cleaning pump failed. The operation manual describes it as being used for membrane cleaning, but it is also used to flush the membranes.
- Residence times in the hydraulic separator and advanced oxidation stirred reactor are based on tank levels. So, if the influent flow rate changes, the tank levels are reached more quickly and residence times are affected. The program is based on a constant influent flow of 5 gpm.

6.2.4 Phase 2 Test Results

6.2.4.1 Operational Tests

Prior to the start of Phase 2 testing, modifications to the Navalis Orion™ system were implemented to improve performance. A larger Rogue pump (RGT 30), ozone dissolving pump, was installed to replace the Rogue RGT 10 to the stirred reactor. To improve system throughput, the water from the membrane feed tank was used to backwash the filters, instead of the effluent in the finish tank. This change required piping and programming changes. Assuming the TSS influent concentration would be higher for a blackwater only influent, the 38-mesh screen replaced the 74-mesh screen in the covered shaker to allow more flow through the screen. A Twin Engineering air dry system was installed to dry the incoming compressed air to the ozone generator based on the Pacific Ozone recommendation. Pacific Ozone stated that dry/oil-free air is required to produce the rated ozone through the generator. ESTCP requested additional sample ports and samples to investigate feed concentrations into the reactor. To further assist in the assessment of the dissolved ozone concentrations entering the reactor, ESTCP approved the installation of two dissolved ozone sensors (Emerson and ATI sensors).

Phase 2 only includes the operational tests. The tests were conducted using the Category A test mixture (100% BW) at an average daily flow rate of 1,500 gpd for twenty-one days and a maximum daily flow rate of 3,126 gpd.

The operational test was conducted 24 March – 28 April 2010. The system operated for 434 hours in the same manner as in Phase 1 except for the changes mentioned above. According to Navalis Environmental Systems representatives, the Orion™ system has never been tested using only vacuum-collected blackwater. The capacity of the system and the amount of sludge that would be generated by the system was not known prior to testing. The Phase 2 maintenance log and analytical data are included in Appendix K.

Cold Start

The cold start was conducted at the end of the test because of the trouble with the UV unit and the clogged filter socks. After the system processed for 422 hours, the system was drained and flushed, the filter socks were replaced, and the 38-mesh screen was cleaned. All of the Navalis Orion™ tanks were filled to the 50% level with potable water, except the reactor was filled to the 100% level.

On April 28th, the cold start was conducted for 12 hours and operators collected samples every four hours. The system processed 483 gallons of blackwater and produced 420 gallons of effluent. No sludge was generated during this period.

The influent was beyond the specified range and about three times stronger than the wastewater used during the Phase 2 testing, but still met the effluent quality threshold within the 12-hour processing period. The results are recorded in Table 17.

Table 17. Phase 2 BW Cold Start Analytical Results

Category A	BOD₅ (mg/L)	COD (mg/L)	TSS (mg/L)	FC (cfu/100 mL)	O/G (mg/L)
Influent Average (5 samples)	2,771	3,750	2,963		57
Test Influent Requirement	780 – 1,700		2,100 – 3,500		50 – 120
Effluent Averages (5 samples)	41	38.2	13.8	3	
Effluent Ranges			≤ 150	≤ 200	
USCG Effluent Limit	≤ 25	≤ 125	≤ 35	≤ 100	

Processing

Based on the estimated design flow rate, Phase 2 was designed to process at least 138,600 gallons of BW. Instead, the system only processed 26,909 gallons of blackwater, while generating 6,086 gallons of sludge. The actual processing rate averaged 1,500 gallons of processed wastewater per day and sludge generation was 22.6% of the processed volume. The system also required 1,090 gallons of potable water to flush the mesh screen. Table 18 summarizes these measurements.

Table 18. Phase 2 BW Processing Summary for 24 March – 28 April 2010

Wastestream	Volume Processed (gallons)	Goal (gallons)
Blackwater	26,909	138,600
Sludge	6,086 (22.6% of processed volume)	Measure and record
Flush Water (potable water usage)	1,096	Measure and record

The system is designed to process 5 gpm of influent wastewater at steady-state conditions. The throughput of the system is largely based on the flows through the mesh screen, tubular filter socks, and ceramic membranes. During Phase 2, the system processed about 1gpm of influent and increased the residence time in the reactor.

Since the size of the mesh screen was increased, more solids passed through the screen that should have been captured in the Flocculator as occurred during Phase 1. The solids actually either stayed suspended in the solution or settled to the bottom of the hydraulic separator. Agitation of the fluid with the air dissolving pump lengthened the suspension time of the solids, which were passed to the intermediate tank. According to Navalís engineers, the MARFLOC 7825 aluminum chlorohydrate may have very little effectiveness on blackwater only influent because there were no colloidal particles and the solids are too heavy for the flocculant to handle alone. Navalís suggested the purchase of a Tomel Polymore unit to handle the heavy solids. No changes were performed to correct the problem. Therefore, the solids were handled within the tubular filter socks and the Kerasep membrane which reduced the throughput dramatically through the socks. The flow through the filter socks was reduced from 5 gpm down to 0.85 gpm. Also, since the backwash of the filter socks used the water in the membrane tank, there was not ample water (as designed) to also flush the ceramic membrane and pass water to reactor. This reduced the system's throughput.

The addition of the air dryer provided the confidence that the ozone generator produced the designed flow of ozone. Also, the larger ozone dissolving pump at the reactor further aided in the wastewater treatment. The dissolved ozone content entering the reactor averaged 4.07 mg/L ozone as measured by the ATI Dissolved Ozone Monitor and 4.4 mg/L ozone as measured by the Rosemount Analytical Dissolved Ozone Sensor. Based on a typical ozone conversion of 4 to 8%

claimed by the ozone generator manufacturer, Pacific Ozone, and the flow rate of air entering the generator, the measured dissolved ozone values were determined to be within normal parameters.

The first objective was to process wastewater within the influent concentration ranges listed in Table 2. The results from Martel Laboratories show that the average parameter values of the influent were within the required range for BOD₅, but the TSS influent average was below the desired average.

Table 19. Phase 2 Influent Composition

Wastewater Parameter	Performance Specification 40-sample Average Range (mg/L)	Actual 40-sample Average (mg/L)
BOD ₅	780 – 1,700	1,054
COD		1,347
TSS	2,100 – 3,500	1,182
O/G		8

Part of the objective was to verify the system could process at the recommended design flow rate. The design processing rates were set at 6,600 gpd for fifteen operating days. The system process rate averaged 1,500 gpd, and therefore the processing rate was not met throughout the evaluation due to the frequent backwashing required for the filter socks and high solids concentration. The flocculator and hydraulic separator were not sufficiently removing the solids. This caused many solids to pass through to each of the intermediate tanks, thus clogging the tubular filter socks. Since the feed to the ceramic membrane was also backwashing the filter socks, very little water was reaching the reactor with ultimately less effluent discharged from the system and the increasing the residence time in the finish tank.

Phase 2 Sampling and Analysis Results

The influent composition specified by the performance specification was met for BOD₅ and O/G, but much lower than the TSS range. The effluent quality was assessed against the thresholds listed in Table 20. The results show that effluent quality was met for all contaminants: BOD₅, COD, TSS, and FC. All average values were much lower than the limits. These results show that the system was capable of adequately removing the organics, solids, and disinfecting the wastewater. A statistical analysis was conducted on all the data. A detailed discussion of the results is located in Technical Note No. 10-167-02, found in Appendix L.

Table 20. Phase 2 Sampling Results

Stream	BOD ₅ (mg/L)	COD (mg/L)	TSS (mg/L)	FC (cfu/100 mL)	O/G (mg/L)
Influent Average (40 samples)	1,054	1,347	1,182		<8
Test Influent Requirement	780 – 1,700		2,100 – 3,500		
Cold Start Averages	38	37	12	1	
Effluent Averages (40 samples)	4	49	1	1	
Effluent Ranges			≤ 150	≤ 200	
USCG Effluent Limit	≤ 25	≤ 125	≤ 35	≤ 100	

Figures 21 through 25 graphically show the influent and effluent analytical results for BOD₅, COD, TSS, FC, and O/G for Phase 2.

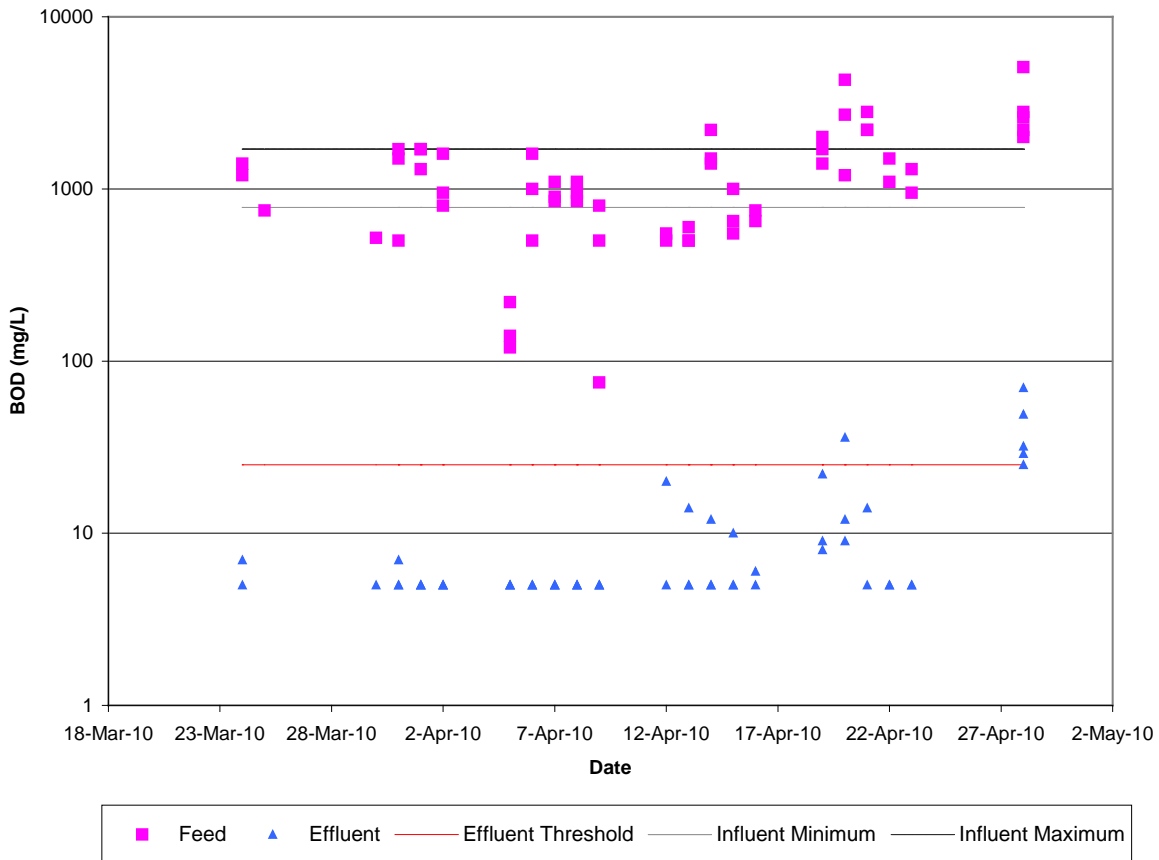

Figure 21. Graph of Analytical Results for BOD₅ for Phase 2

Figure 21 shows the effluent BOD₅ concentration met the threshold throughout Phase 2 testing with the exception of one sample. Most of the samples exceeded the threshold during the cold start test that was conducted on 28 April 2010. Most of the influent BOD₅ concentrations ranged from 500 mg/L to 3,000 mg/L with an average of 1,187 mg/L. The BOD₅ concentration was reduced by 99% during Phase 2, instead of the 95% reduction in Phase 1. Since the effluent BOD₅ concentration values are lower than those recorded in Phase 1, it is apparent that oxidation in the Navalis process was improved by the changes made prior to the evaluation. Measured dissolved ozone concentrations ranged from 0 to 10.4 mg/L.

Figure 22 shows the average effluent COD concentration was below the threshold for all but two samples collected during Phase 2. The influent concentration range was 100 – 3,100 mg/L with an average of 1,579 mg/L. There was a 94% reduction in COD levels.

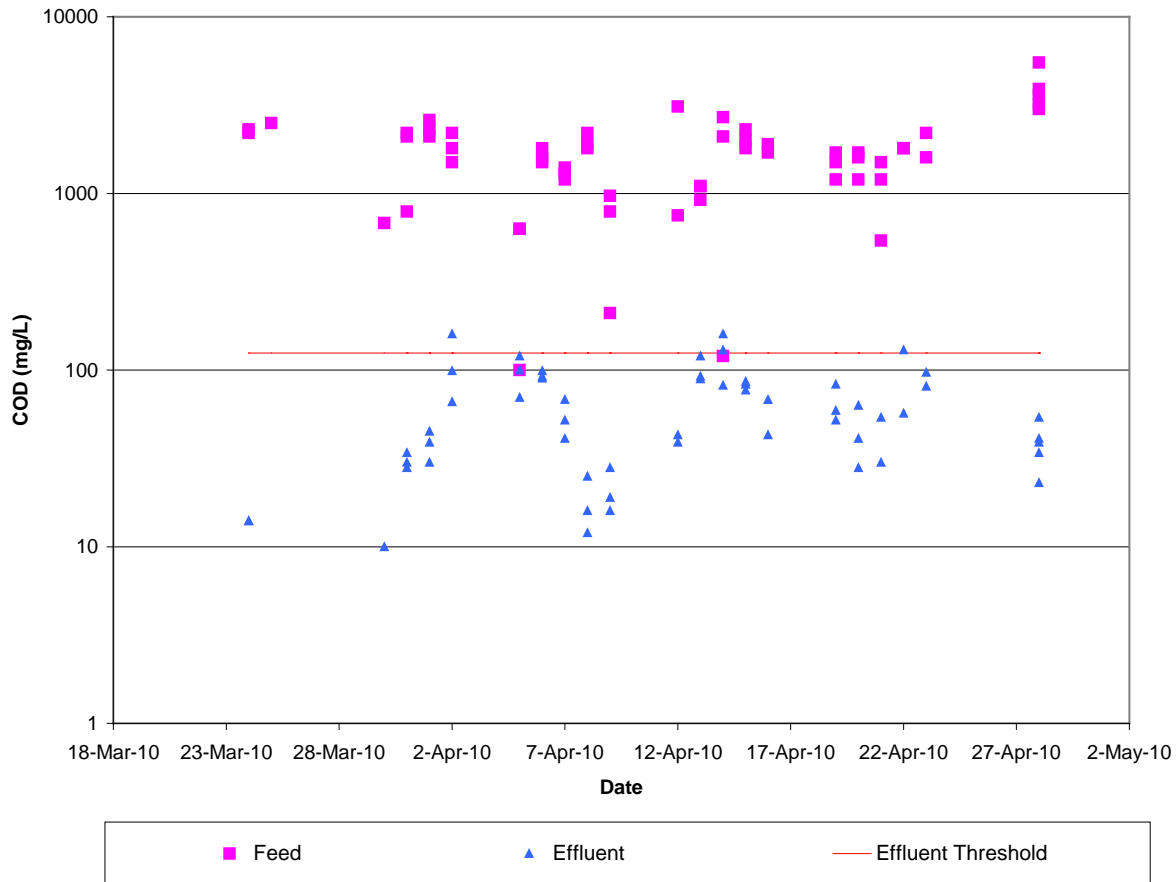

Figure 22. Graph of Analytical Results for COD for Phase 2

Figure 23 shows the average effluent TSS concentration was below the threshold for all samples collected during Phase 2. The influent concentration range was 78 – 2,300 mg/L with an average concentration of 1,324 mg/L. Based on the results seen during both the Phase 1 and Phase 2, evaluation the Navalis Orion™ system has easily removed the solids from the wastewater regardless of the concentration.

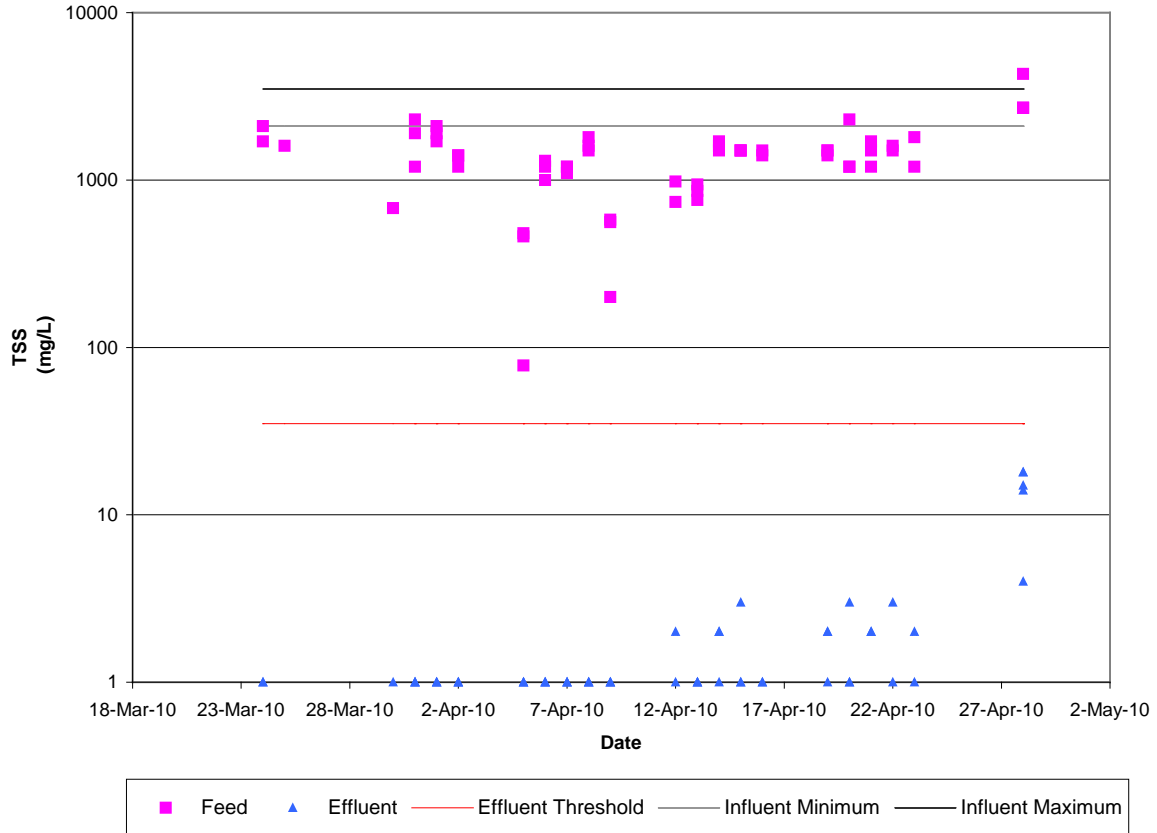

Figure 23. Graph of Analytical Results for TSS for Phase 2

Figure 24 shows the effluent FC concentration was consistently met during Phase 2 testing. The results were similar to the results of Phase 1.

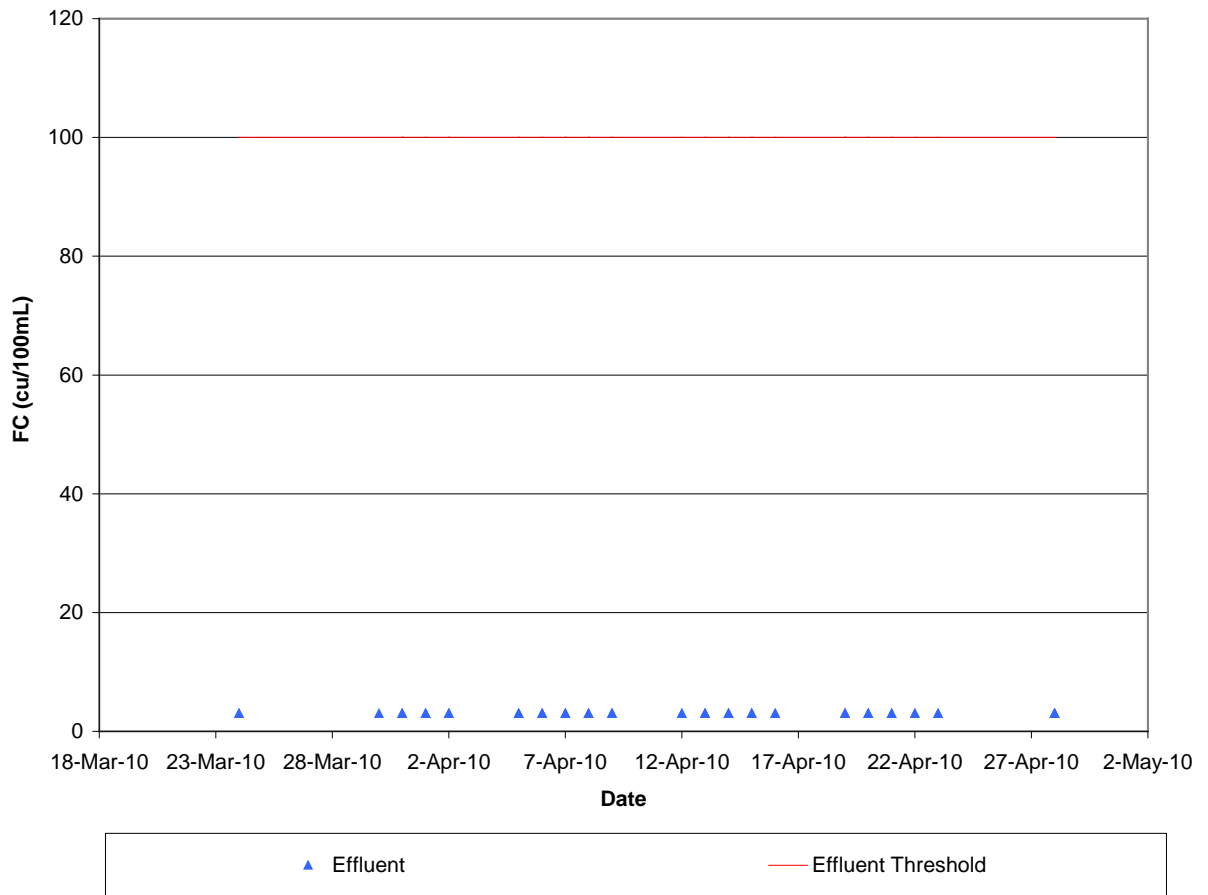

Figure 24. Graph of Analytical Results for FC for Phase 2

Membrane Recovery Analysis

Using the same formula as written in Phase 1, the membrane permeate flow rate averaged 0.5 gallons per minute and the membrane feed flow rate averaged 2.0 gallons per minute. This low flow rate was due to more solids in the membrane feed water than seen during Phase 1 and the multiple backwashes that was required to increase the flow through the tubular filters. These factors lowered the volume in the membrane feed tank, which caused more water to transfer back to the AET via the program timer of flushing the membrane loop prior to discharging permeate to the reactor. Therefore, there was only a 25% membrane recovery during Phase 2 evaluation.

Solids Holding and Sludge Generation

The actual sludge generation was 6,086 gallons of sludge, which resulted in 22.6% of the process volume. The sludge generation was higher than during Phase 1 due to the higher level of contaminants in the influent waste stream. Again, the sludge generation may be reduced if a turbidity sensor was used to determine sludge between clarified water.

Sludge Reduction Treatment Analysis

The sludge reduction analysis was not conducted for the same reasons as in Phase 1.

Maintenance

Prior to the start of Phase 2 testing, the ceramic membrane was cleaned as recommended by Navalis. This cleaning consisted of the use of an acidic and basic cleaning agent and took about 2 hours to complete. The 74-mesh screen was replaced with the 38-mesh screen. Also, the tubular filter socks were replaced with a new clean set of filter socks of the same size.

The same maintenance was conducted in Phase 2 as in Phase 1, except the chemical tank was refilled each day because the chemical rate was increased due to the higher concentration of solids in the wastewater.

In addition to the usual maintenance, operators were constantly managing a leak from the UV unit. One of the seals on the wiper mechanism was worn and suspected to be the source of the leak. Approximately 3-4 gallons of water leaked daily through the UV unit. The reliability of the UV unit was compromised and the UV lamp operated inconsistently.

After three operating days, the filter socks were completely clogged and were replaced. Operators increased the frequency of the bag filter backwashing cycle from 5 seconds every 90 seconds to 5 seconds every 60 seconds. This action helped maintain some flow through the filter socks. By design, the flow through the filter socks should be at least 5 m³/hr and the average flow through the socks was only 0.85 m³/hr. This reduced flow attributed to the low throughput of the system.

Phase 2 Implementation Issues

- Processing a different influent wastewater stream required re-adjustment of the seven ball valves to allow adequate air to enter the Flocculator tubes without confirmation that the operator achieved the optimum setting.
- The Shaker Screen mesh size again need to be tested with the new influent stream
- The Operator Manual contains incomplete or missing information on how to address system issues. "Operator must troubleshoot" is a statement in the manual when trying to rectify the problem. This is not enough guidance. There is no information provided on what conditions must be met before the UV unit turns on, or how to optimize the air being dissolved into the Flocculator.
- Lack of detailed program instructions or explanations left the operator with little information on system issues. Sometimes the system recirculated the tanks and without detailed program instructions, the operator had no idea what the system was "waiting for" or what actions, if any, were needed. There were major transitions between the system running full bore and seemingly being idle, without any indication why.
- Pumps became vapor locked without the system acknowledging an issue. The system should be able to realize there is a low pressure on the pump and provide a warning that there is a problem with the pump.
- The system required a constant balancing act between suction and discharge valves on the sludge ozone dissolving pump P-10, which required frequent adjustments and multiple potential run-states. This was also a problem when the SRT level was too low.
- Heavy solids passed through the hydraulic separator and clogged the filter socks.
- Programming running in steady state had dramatically different values for flow rates and pressures from one day to the next, without any perturbation from a user.
- The volume in the membrane feed tank was not adequate. Based on the timing in the program to backwash the filters, a portion of the water was transferred after backwashing to the AET, and the remainder to the reactor. Many times the reactor did not receive any water because the low tank level was reached.
- When the Finishing tank reached a low level, it caused the advanced oxidation stage to shutdown. Programming and/or equipment should prevent this from happening.
- The condition of the SRT and SDT filling quickly create an alert to check the mesh screen.
- The flocculent chemical and system needs to be optimized for each specific wastewater type.

Table 21 summarizes Phase 1 and Phase 2 results.

Table 21: Performance Objectives Results

Performance Objective	Success Criteria	Phase 1 Combined Blackwater and Graywater Laboratory Results	Phase 2 Blackwater Laboratory Results
Meet Effluent Quality Standards	BOD ₅ ≤ 25 mg/L COD ≤ 125 mg/L TSS ≤ 35 mg/L FC ≤ 100 cfu/100 mL 6 < pH < 8.5	Not Met BOD ₅ = 60 mg/L COD = 145 mg/L TSS = 1.6 mg/L FC = 5.6 cfu/100 mL pH = 6.8	Not Met BOD ₅ = 3.8 mg/L COD = 49 mg/L TSS = 0.7 mg/L FC = 1.0 cfu/100 mL pH = 6.1
Meet Minimum Startup Time	≤ 12 hrs	Not met	Not met
Meet Treatment Capacity	Average daily volume processed: 6,600 gpd for 12 days and Maximum daily volume processed: 7,200 gpd for 3 days	Not Met (78% of rated capacity) Average – 4,023 gpd Max – 5,134 gpd	Not Met (22% of rated capacity) Average – 1,500 gpd Max – 3,126 gpd
Demonstrate Level of Operator Involvement	Run and record	Regular Daily Maintenance 5 – 40 minutes Special Maintenance 0.5 – 3 hours	Regular Daily Maintenance 5 – 40 minutes Special Maintenance 0.5 – 3 hours
Demonstrate System Reliability	No critical component failures MaxTTR ≤ 12 man-hrs (non-critical)	No critical component failures	UV disinfection unit

7.0 Cost Assessment

7.1 Cost Model

Current methods to meet effluent discharge regulations entail the use of holding tanks vice treatment. Now, with more restrictive requirements anticipated, a treatment system is needed. The use of a treatment system is not a decision made in order to realize a cost savings. Using a treatment system is the only way to complete a mission successfully and meet environmental regulations. Retrofit of systems would be cost prohibitive. In most cases, space is not even available onboard ship for a properly sized treatment system and retrofit is not an option. The focus will be on forward fit implementation.

In completing a cost/benefit analysis, the cost of successfully completing a mission is not known. The cost of altering a mission in order to move to an area where discharges are allowed is not known and would vary with each mission.

Comparing the cost of purchasing, installing and operating a holding tank cannot be compared to the same costs for a treatment system. The treatment system is an additional capability with higher costs. A treatment system cannot directly replace a holding tank, which is the existing technology, but will be an addition. The holding tank is normally part of the ship's Collection, Holding and Transfer (CHT) system and must remain installed for proper operation of the CHT system. The original volume of the tank may no longer be needed after a treatment system is added. The ship would potentially have the option to replace the holding tank with another of lesser volume. Conversion of the space and weight into monetary savings is not known.

Tangible cost savings are associated with in-port disposal, if a port allows effluent discharges. The monetary savings for each ship is immediate.

For all these reasons discussed, a formal cost/benefit analysis could not be performed. Instead, costs were documented for the installation and testing of the Navalis Orion™ system.

The costs of installing, purchasing and operating a Navalis Orion™ system are categorized and listed in Table 22 with a description following for each factor.

Table 22. Navalis Orion™ Cost Factors

Direct Costs		Indirect Costs
Start-Up	Operation & Maintenance	
- Equipment Purchase	- Operation (Labor)	- Integrated Logistics Support
- Equipment Design	- Utilities	- Sample Analysis
- Mobilization	- Waste Disposal	- OSHA/EHS Training
- Installation	- Maintenance & Repair	
- Training	- Consumables	

Start-Up costs include the following:

- *Equipment Purchase* – The full purchase price of the capital equipment.
- *Equipment Design* – The engineering hours required to size the equipment to meet the needs of a specific ship and mission.
- *Mobilization* – The cost of setting up the technology on the ship which includes NAVSEA Ship Maintenance (SHIPMAIN) planning and approvals, contracting labor, equipment shipping costs to the ship and travel costs.
- *Installation* – The ship installation costs, which will vary by ship.
- *Training* – Operator training costs will be estimated.

Operation and maintenance costs include the following:

- *Operation Labor* – The cost of operator hours required to run the equipment.
- *Utilities* – The cost of power and water (air) for the equipment to function.
- *Waste Disposal* – The cost of sludge disposal and labor hours associated with transfer or storage of the sludge for disposal.
- *Maintenance and Repair* – The cost of equipment and labor needed to maintain, replace and repair parts.
- *Consumables* – The cost of process chemicals, personal protective equipment and supplies.

Other indirect costs include the following:

- *Integrated Logistics Support (ILS)* – The development of new or modified ship documentation for operation of the system.
- *Sample Analysis* – The laboratory costs to analyze samples to confirm effluent quality.
- *Occupational Safety and Health Administration (OSHA)/EHS Training* – The costs to train operators on ozone and chemical safety.

Navalis Environmental Systems has estimated the Life Cycle Cost (LCC) for the Navalis Orion™ system. The factors for determining LCC are (1) equipment maintenance and repair, (2) process chemicals and consumables, (3) labor for operation, maintenance and repair and, (4) utilities. The LCC is based on a 20-year life cycle.

7.2 Cost Analysis and Comparison

The costs of installing, purchasing and operating a Navalis Orion™ system in the laboratory were collected during the laboratory demonstration and documented. The shipboard demonstration was cancelled. Only a portion of the costs associated with a shipboard installation could be estimated. All costs did not apply to the laboratory testing or could not be estimated for a theoretical ship installation. Each cost factor value is discussed in this section and illustrates the complicated process of estimating the associated costs of new complex shipboard systems. The laboratory testing and shipboard estimated were used to evaluate and confirm the LCC calculated by the manufacturer. A spreadsheet with assumptions and calculation details is included in Appendix M.

7.2.1 Direct Costs - Start-up

Start-up costs have been broken into separate categories, including the purchase of the equipment, additional costs for equipment design, the transport and installation of the system, and the training required to have knowledgeable people able to operate it.

The initial purchase price of the Navalis Orion™ Model 5 system was \$299,250, which included site delivery and installation. A shipboard system would be more expensive in order to harden the system to meet military specifications.

The Navalis Orion™ system is available in four sizes, depending on treatment capacity required. While the Orion tested at NSWCCD had a treatment capacity of 7,200 gal/day, two larger models are available. The Model 10 treats up to 14,400 gal/day, and the Model 15 can treat up to 22,200 gal/day. Naturally, for larger treatment capacities onboard ship, both of these models have greater footprint, weight, power consumption, and consumable usage. Apart from increased cost of a higher-capacity model, no additional costs are anticipated from an equipment design standpoint. One of the existing models would be chosen for a shipboard installation with possible multiple units to ensure treatment capacity.

Concurrent with the laboratory installation of the system by Navalis Environmental Systems, the system facilities (air, electrical, plumbing, etc.) were completed by three NSWCCD technicians over 3 work days. On a naval vessel, the cost for installation would not be directly comparable. A time consuming approval process and outside contractor labor are required for shipboard installation. Without a specific ship identified, a cost estimate for a shipboard installation could not be estimated.

NSWCCD received no formal training on the operation or maintenance of the Navalis Orion™ system. Knowledge of the system was gained through hands-on examination, testing, and comparison to system documentation. While this proficiency was gained over an estimated three weeks in a non-structured setting, a structured training environment is estimated to achieve a similar level of proficiency in three days. For four operators and two supervisors, the combined manpower cost of training for three days will be \$2755. Navalis offers onsite training for \$1150/day plus travel expenses. Using a conservative estimate of \$1500 for travel expenses, the Navalis cost of training would approach \$4950. Therefore, the combined cost of having Navalis provide training to four operators and two supervisors over three days is estimated at \$7700.

7.2.2 Direct Costs - Operation and Maintenance

A significant amount of the ongoing costs of a treatment system is the cost to operate and maintain the system. Six primary cost drivers have been identified for consideration including operational labor, utilities consumed by the system, waste disposal, replacement parts required to maintain the system, labor required to repair the system, and consumables.

Although the manufacturer projected labor estimates for system operation, including 30 operator hrs/month and 4 supervisor hrs/month, NSWCCD has significantly increased the operation labor required based on observations during testing at Carderock. Labor during the laboratory

evaluation was \$55,700 for 12 hours per day during Phase 1 and Phase 2, but is not representative due to the need to document instrumentation readings throughout the test. The labor rates at NSWCCD are also higher than for shipboard operators. The projected estimate for shipboard operator involvement is increased to 150 hrs/month (\$2730/month) and supervisor involvement is increased to 20 hrs/month (\$420/month), or a combined cost of \$3150/month.

The two primary utilities of concern on the Navalis system are energy consumption and compressed air usage. The system requires an electrical service that can provide 3-phase, 480V at 40amps. At 100% usage, or 7200 gal/day, Navalis literature claims 14,479 kW-hr energy consumption per month, or approximately 475 kW-hr per day. At an average price of \$0.125/kW-hr, the approximate cost is \$1,810 per month.

From data obtained during Phase 2 testing at NSWCCD, the maximum amount of water fed from the AET, which includes raw wastewater and recycled, was 2600 gal/day, with a corresponding energy consumption of 360 kW-hr per day. By modeling 22 separate days of energy consumption and extrapolating out to the theoretical maximum of 7200 gal/day, a logarithmic plot predicts less than a 1% variation from the Navalis reported usage as depicted in Figure 26. Therefore, the monthly estimate of \$1810 for energy consumption is supported.

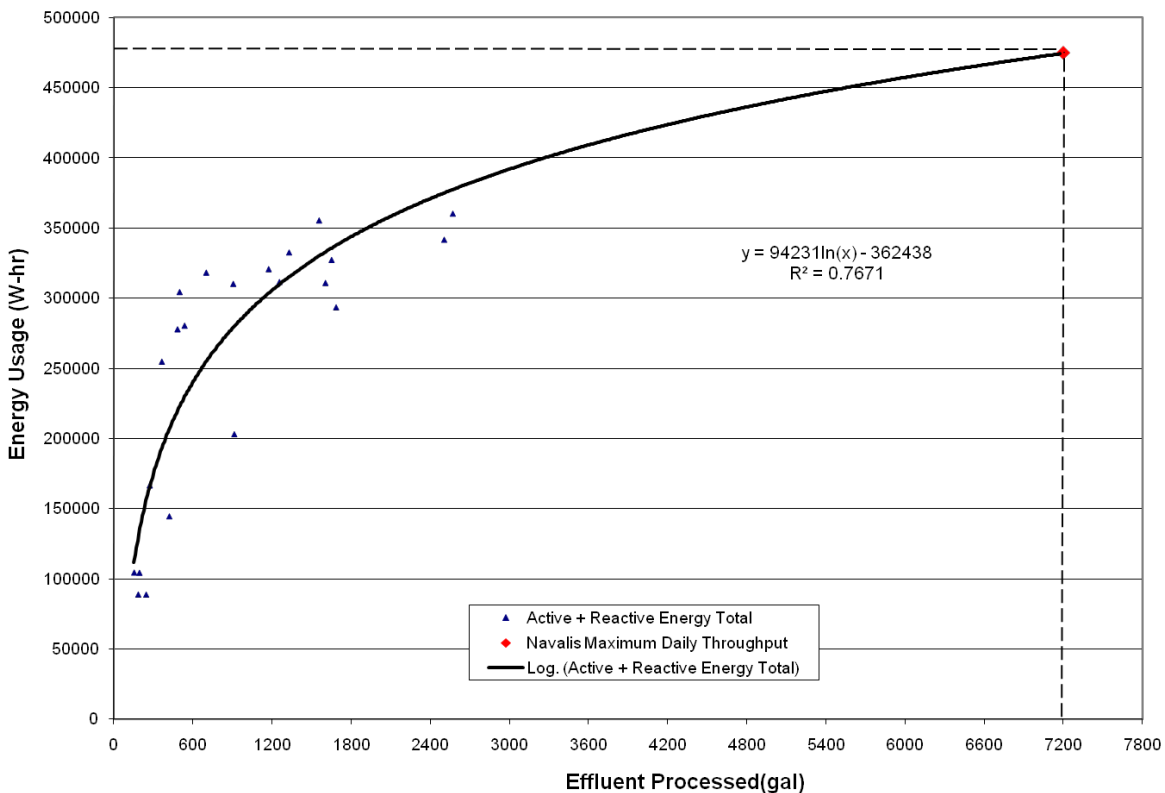

Figure 26. Graph of Energy Usage versus Effluent Processed

The system also requires 6 scfm of compressed air at 30 psig with a dew point of -80°F or below. The air is primarily used to feed the ozone generator, which requires the air to be clean and dry to prevent fouling of the generator. Although all ship classes have the capability of delivering

the required air flow rate, after investigation of potential ship classes, none appear to be able to meet the ultra low-moisture requirement required by the ozone generator. During Phase 1 testing, NSWCCD-supplied air was also insufficiently dry, so a regenerative desiccant dryer was purchased at a cost of \$1640 to remove moisture from the facility-supplied compressed air supply. The addition of the desiccant dryer however, also introduced a large pressure drop to the system that required the air supply to be increased to 80 psig. The compressed air source at NSWCCD supplies many laboratories in the building, so a cost only for the Navalis Orion™ testing could not be calculated. The cost to deliver compressed air at these conditions shipboard has been requested from the Life Support and Compressed Air Systems Branch of NSWCCD and is not yet available. Compressed air costs were not included in the Navalis estimate.

Treatment of ship waste will generate a volume of sludge that must be stored until it can be discharged or transferred off the ship. As currently designed, the Navalis Orion™ system software periodically sends a volume of sludge to an external storage tank which is not part of the system. Testing at NSWCCD has shown that 4 gallons of sludge are generated for every 21 gallons of combined graywater and blackwater processed. At the theoretical maximum, the Navalis Orion™ system will therefore generate approximately 1370 gallons of sludge every month. Considering that disposal could occur in Navy and non-Navy ports, monthly disposal costs could approach a high of \$825.[15] Laboratory sludge was discharged to the sewer as specified by NAVFAC, so no costs were incurred.

Navalis Environmental Systems has provided a list of spare parts recommended to have available for routine repair at an annual price of \$5460. These parts comprise the majority of the maintenance events that will occur and repeat within the first year. Navalis Environmental Systems estimates the parts on this list to have a 2-3 week lead time for order replacement so operational logistics may dictate the need to keep additional spares on hand.

A second category of parts for replacement are on a longer-term repair cycle of two to ten years. These include higher-price items such as replacing the ozone generator after ten years and replacing the ceramic membrane after five years. Navalis Environmental Systems employs a net present value with discount rate of 5% over a 20-year service life. This translates to an additional \$3100 per year.

In addition to operational labor, NSWCCD has identified specific repair events that will require additional manpower commitments. For shipboard operation, the tasks for removal, cleaning, and replacement of the shaker screen will require 2 people every week for 2 hours at a projected cost of \$290/month. Replacing the filters will require 2 people every 2 weeks for 2 hours at a projected cost of \$145/month. The combined labor dedicated to maintenance and repair is \$435/month. During Phase 1 and Phase 2 testing, operator labor required was documented for maintenance and repairs as 15 operator-days (\$14,700) in Phase 1 and 23 operator-days (\$22,500) in Phase 2. Again, rates are higher for labor at NSWCCD than on a ship.

The Navalis Orion™ system has one solid chemical consumable and three liquid chemical consumables that are used in normal operation of the system. Ozone destruct media must be periodically exchanged as a safety measure to prevent operator exposure to ozone. This is replaced every 6 months at an annual cost of \$500. This was not required during the laboratory

evaluation. Two membrane wash chemicals are used to prevent build-up of fouling materials on the membrane. Predicted usage for each wash chemical is 4 liters per month, for a combined annual cost of \$450. An aluminum chlorohydrate flocculant is used to aggregate the coagulated particles to form larger flocules and thereby hasten gravitational settling. Although Navalis predicts usage of 4 liters per month, NSWCCD consumption was noticeably higher, leading to a projected annual cost of \$1100. The actual total chemical cost during the laboratory evaluation was \$220.

The two primary exposure risks are ozone gas from the ozone generator and biological hazards from the wastewater. Normal personal protective equipment (PPE) for wastewater/sewage industry workers can be employed to mitigate risks from potential exposure to sewage. The PPE recommended for wastewater workers includes gloves, goggles, faceshield, respirator, and water-resistant smock or apron. To minimize the risk of cross-contamination, PPE gear used around wastewater should not be used around non-wastewater systems. Assuming gear for 4 operators, the PPE cost estimate is \$563.

7.2.3 Indirect Costs

In addition to the costs directly related to the Navalis Orion™ system, additional costs need to be considered, including those related to performing sample analysis to verify the system is operating properly, any costs required to provide safety training associated with the hazards of sewage handling and hazardous gas exposure, and logistic concerns.

Although routine sampling of certified Type II MSDs is not required, to troubleshoot and confirm the performance of the Navalis Orion™ system while deployed, the vessel must have the ability to perform specific tests for the parameters regulated by MARPOL. These parameters include BOD₅, COD, TSS, FC, and pH. Initial purchase of the analytical equipment required to perform these tests is estimated at \$8400. This does not include the cost to convert a space into a laboratory to house and operate the equipment or extra labor to complete the tests. Laboratory evaluation sampling and analytical costs are higher than shipboard estimates and do not correlate to shipboard estimates.

Any personnel expected to work on or around a system that uses ozone should be adequately trained regarding the symptoms and health risks associated with short-term and long-term exposure. For ozone, OSHA has established an 8-hr exposure limit of 0.1 ppm and a 15-min acute exposure limit of 0.3 ppm. Additionally, if the system is idle long enough for any wastewater to become anaerobic, there is a risk of formation of hydrogen sulfide gas. Although the Navalis Orion™ system employs ozone detection sensors, as well as a hydrogen sulfide gas sensor, comprehensive training must be performed so that any operator or supervisor is aware of any potential risks.

In the case of certain safety hazards in private industry, a safety class to cover the risks associated with sewage treatment and hazardous gas protection could approach \$1200 per person for a single day safety class, or \$7200 for four technicians and two supervisors. The Navy would need to consider whether current safety training would be sufficient, due to the hazards currently onboard a Navy vessel.

Many factors affect the cost of ILS for new shipboard equipment. The fact that the Navalys Orion™ system is complex increases the ILS cost. The following is a list of ILS documentation that would be affected by a new MSD:

- Revise Sewage Disposal Operational Sequencing System.
- Revise Preventative Maintenance Schedule (PMS), which includes development of PMS cards for the system and revision to the Maintenance Index Page that lists the PMS cards and makes the cards applicable to the effected ship.
- Convert commercial Tech Manual into a Navy manual. This could be a large expense depending on the number of pages of the tech manual.
- Revise Coordinated Shipboard Allowance List and develop Allowance Parts Lists. This will depend on the number of parts ship's force would need to carry onboard to support the Navalys Orion™ system.
- Revise Ship Drawings. This is expensive and includes both tech code labor and shipyard labor.
- Revise Ship Information Book.
- Certify ILS.
- Revise/develop a checklist for the system.

Based on this list, ILS revision would require a minimum of 6 man-months and over \$150,000 of shipyard labor. Better estimates can be obtained by knowing how the system will be integrated into the ship.

7.2.4 Life Cycle Costs

To summarize the LCC cost analysis, Navalys Environmental Systems estimated LCC at \$30,900. Based on actual laboratory experience and shipboard estimates, NSWCCD determined the Navalys value to be low and calculated an LCC of approximately \$70,000. These values do not include the costs of compressed air and waste disposal, which are real costs that will increase the value of the NSWCCD estimate further. The major variance from the estimates was from labor costs for operation, maintenance and repair of the system. Table 23 summarizes the estimated yearly values for the LCC cost factors.

Table 23. Navalys Orion™ Life Cycle Cost Estimate by NSWCCD

LCC Cost Factors	Yearly Cost
Equipment Maintenance & Repair (Parts)	\$ 8,560
Process Chemicals & Consumables	\$ 3,700
Equipment Operation (Labor)	\$37,800
Equipment Maintenance & Repair (Labor)	\$ 5,220
Utilities (Electric)	\$21,720
Total	\$77,000

8.0 Implementation Issues

8.1 Stakeholders and Implementation

The NAVSEA Technical Warrant Holder (TWH) for Ship Environmental Protection (NAVSEA 05P25) recommends treatment technology for new design Navy ships. The goal is to change American Bureau of Shipping Naval Vessel Rules, Part 5, Chapter 7, Section 7 to recommend advanced oxidation as an appropriate treatment system technology for new US Navy ships and retrofits of older vessels.[16] The success of the demonstration will also be documented in the NAVSEA Non-Oily Technology Identification and Assessment Process (TIAP) summary for the TWH. When participating in the design of new ships, the TWH will have documentation to recommend advanced oxidation technology. NAVSEA 05P25 has driven the development and finalization of the Performance Specification, MIL-PRF-30099, which is approved for use by all Department Of Defense departments and agencies which outlines acceptance criteria for the treatment systems on Navy ships.

8.2 Transition Impacts

Overall, the evaluation has demonstrated that advanced oxidation using ozone and ultraviolet light is a potential technology for the treatment of blackwater and graywater generated on a military vessel and warrants further testing. The objective was to evaluate advanced oxidation technology. The Navalis Orion™ Model 5 Advanced Oxidation Wastewater Treatment System is one of the commercial wastewater treatment systems available. To help improve the system performance and correct issues, optimization is needed.

The Navalis Orion™ can successfully treat a portion of shipboard wastewater. Phase 2 successfully produced acceptable quality effluent. The AOSR residence time should be modified to be controlled by time and not by Finishing Tank volume. Since the capacity for Phase 2 was reduced, the recirculation time through the AOSR was high. Phase 1 testing should be repeated to confirm that the modifications are also successful for combined blackwater and graywater, especially since the manufacturer designed the system as a combined blackwater and graywater treatment device.

The goal is not only to identify commercial wastewater treatment systems that can process high strength wastewater, but that also require only minimal operator interaction and meet specific ship size and weight restrictions. The capacity of the system is an issue for a ship installation. The Navalis Orion™ is rated to treat approximately 6600 gpd, but only demonstrated a capacity of 4023 gpd of combined blackwater and graywater and 1500 gpd of blackwater. The solids removal stage needs optimization to increase wastewater flow through the system and to reduce sludge generation. This will reduce the size of the unit and reduce the volume of sludge storage required.

The system did not demonstrate a low level of operator intervention. The system is complex and training is required. The programming and automation should be optimized. Improved operator tools are also needed, such as a more complete and detailed Operation, Maintenance and

Installation manual with better troubleshooting guidance and automation/programming descriptions.

The system reliability was demonstrated in Phase 1 with no critical component failures. However, in Phase 2, the UV unit did not operate reliably. A better understanding of how the UV unit is programmed with the system and how to maintain the unit is needed from Navalis.

Any new regulations will only aid in the transition of an optimization system. More stringent effluent quality standards are anticipated and will stress the need for wastewater treatment technologies.

Implemented equipment will most likely be custom-built for each ship class depending on space availability and ship specification. This can be handled with multiple designs or installation of multiple single units that together will provide the needed capacity. Since no other treatment systems for combined blackwater and graywater have been built, scale-up issues could be an issue. No proprietary or intellectual property rights issues are anticipated. The system can be purchased by any vessel with the need. The Navalis Orion™ Model 5 purchased for this test was a standard size and not customized specifically for this demonstration. However, the system capacity was the highest that could be supported by the laboratory facilities.

8.3 Technology Transfer Plans

Further testing of the Navalis Orion™ will be performed in a Phase 3 test to evaluate the equipment modifications made after the Phase 1 test. In Phase 3, the system will process combined blackwater and graywater. Phase 2 effluent quality results were favorable, but the processing rate for the blackwater influent was very low and potentially increased the residence time in the reactor. The effluent quality needs to be confirmed while processing combined blackwater and graywater at the rated capacity.

9.0 References

1. "Federal Water Pollution Control Act," As Amended (33 U.S.C 1251 et seq.)
2. International Maritime Organization, "International Convention for the Prevention of Pollution from Ships," (MARPOL 73/78).
3. OPNAVINST 5090.1C (series), Environmental and Natural Resources Program Manual, Chapter 22, Environmental Compliance Afloat
4. Metcalf & Eddy, Inc., *Wastewater Engineering: Treatment, Disposal, and Reuse*, 3rd ed., (McGraw-Hill, Inc., 1991), p. 349.
5. Beltran, Fernando J. *Ozone Reaction Kinetics for Water and Wastewater Systems*, (Lewis Publishers, 2004), p. 193.
6. "Performance Specification, Treatment System, Blackwater and Combined Blackwater/Graywater, for Surface Ships," MIL-PRF-30099, June 2006.
7. Riggs, S., "Updated Analysis of Wastewater Treatment System Effluent Quality for Alaska Cruise Ships and Ferries (2000-2009)," NSWCCD-63-TR-2010/XX+CR, August 2010.
8. United States Code of Federal Regulations, Title 33, Volume 2, Part 159, "Marine Sanitation Devices."
9. United States Code of Federal Regulations, Title 40, Volume 19, Part 140, "Marine Sanitation Device Standard."
10. International Maritime Organization, Marine Environmental Committee, "Recommendation on International Effluent Standards and guidelines for Performance Tests for Sewage Treatment Plants," Resolution MEPC.2(IV), 3 December 1976.
11. International Maritime Organization, Marine Environmental Committee, "Revised Guidelines on Implementation of Effluent Standards and Performance Tests for Sewage Treatment Plants," Resolution MEPC.159(55), 13 October 2006.
12. "Shock Design Criteria for Surface Ships," NAVSEA 0908-LP-000-3010 Rev. 1, September 1995.
13. "Military Specification, Shock Tests, High-Impact Shipboard Machinery, Equipment, and Systems, Requirements for," MIL-S-901D, 17 March 1989.
14. American Water Works Association, "Standard Methods for the Examination of Water and Wastewater," 21st Edition, 2005.
15. BMT Designers & Planners "Navy Surface Ship Waste Disposal Costs – Projected (2006-2030), Revision IIIA," April 2006, p. D-11.
16. American Bureau of Shipping Guide for Building and Classing Naval Vessels, Part 5 (Auxiliary Machinery Systems) Chapter 7 (Environmental Protection Systems) Section 7 (Sewage and Graywater), July 2008.

Appendix A: Points of Contact

Points of Contacts

Point of Contact	Organization	Phone/Fax/E-mail	Role in Project
Tina Lerke	NAVSEA Carderock, Code 6330 9500 MacArthur Blvd W. Bethesda, MD 20817	<u>Phone:</u> 301-227-5157 <u>Fax:</u> 301-227-5549 <u>E-mail:</u> tina.lerke@navy.mil	Lead Principal Investigator, will lead laboratory and shipboard evaluation efforts at NAVSEA Carderock
Sheila Riggs	Same as above	<u>Phone:</u> 301-227-5198 <u>Fax:</u> 301-227-5549 <u>E-mail:</u> sheila.riggs@navy.mil	Senior Engineer, will lead laboratory evaluation at NAVSEA Carderock
Robert Heyburn	NAVSEA Carderock Code 6690 201 State Route 34 South Coltsneck, NJ 07722	<u>Phone:</u> 732-866-2020 <u>Fax:</u> 732-866-1135 <u>E-mail:</u> robert.heyburn@navy.mil	Senior Engineer, will lead review and approval of the DDAM analysis
Stephen Markle, P.E.	Navalis Environmental Systems 1212 Burtonwood Court Alexandria, VA 22307	<u>Phone:</u> 703-765-4041 <u>Fax:</u> 703-997-2525 <u>E-mail:</u> spmarkle@navalissystems.com	Co-Investigator, will lead system construction and DDAM analysis for Navalis Environmental Systems
Michael Chapkovich	NAVSEA Isaac Hull Avenue, SE Building 197 Washington Navy Yard Washington, DC 20376	<u>Phone:</u> 703-202-1799 <u>Fax:</u> <u>E-mail:</u> michael.chapkovich@navy.mil	Participating sponsor, Ship Environmental Program Manager, SEA 05P25

**Appendix B: NSWCCD Code 669 DDAM Unclassified Coefficient
Memorandum**

Fr: John Marriott
NSWCCD
Code 6690
732.866.2667 (w)
732.866.1135 (f)
732.625.1061 (cell)

26 Feb 09

To: Tina Lerke
NSWCCD
Code 6330
301.227.5549 (f)

Subj: UNCLASSIFIED DYNAMIC DESIGN ANALYSIS METHOD COEFFICIENTS FOR HULL SYSTEMS

1. Following are unclassified DDAM inputs used for subject systems.

Ship Type: Surface Ship

(I) Hull Mounted Systems

(i) Reference Equations

$$A_o = 20 \left[\frac{(37.5 + W_j)(12 + W_j)}{(6 + W_j)^2} \right], \quad (g)$$

$$V_o = 60 \left[\frac{(12 + W_j)}{(6 + W_j)} \right] \quad (\text{in/sec})$$

(ii) Design Values

Table V

	Elastic		Elastic-Plastic	
	A_j	V_j	A_j	V_j
Vertical	1.0 A_o	1.0 V_o	1.0 A_o	0.5 V_o
Ahwardships	0.4 A_o	0.4 V_o	0.4 A_o	0.2 V_o
Fore and Aft	0.4 A_o	0.4 V_o	0.4 A_o	0.2 V_o

2. If you have any questions pertaining to this matter you can contact me at above numbers.

Appendix C: Detailed Test Requirements

DETAILED TEST REQUIREMENTS

Background

The test plan documents the requirements for checkout and testing of the Navalis Orion[®] system. Six of the tests in the plan require details specific to this MSD. This appendix includes the additional requirements and information specific to the Navalis system for tests 1-7, 1-25, 1-26, 1-27, 1-28, 1-32, and 2-9. Always follow the detailed operating instruction provided with the MSD and in the operation manual when performing any of these detailed tests.

Test 1-7, Sampling Ports

Three sample ports are required but ten are provided on the Navalis Orion[®] system as listed in Table C-1. See Drawing NES-ORI05-PI00 Rev 10 in Appendix A for exact location. Check and verify each of the ports and indicate the results in the table below. Document the overall result in Table 5 of the main test plan.

Table C-1. Test 1-7, Sampling Ports

Description	Success Criteria and Result (Y/N)	Y/N	Comments
Inlet sample port	System has a sample connection on the inlet line adequate to draw a sample of the feed water.		
From Intermediate Tank			
From Hydraulic Separator to Intermediate Tank			
From Hydraulic Separator			
From Hydraulic Separator to Sludge Tank			
From Flocculator			
Permeate Discharge to Reactor Tank			
From Membrane Feed Tank			
Treated Water Discharge – Effluent sample port	System has a sample connection on the inlet line adequate to draw a sample to check discharge requirements.		
From Sludge Tank – Sludge sample port	System has a sample connection on the sludge tank drain line adequate to draw a sample of sludge close to the bottom of the tank.		
From Sludge Decant			

Test 1-25, Operating Modes

The performance specification requires that MSDs have operating modes and that they be tested to verify that they have been provided and function properly. Review the operation and maintenance manual, check the Navalis Orion[®] system for these modes, and record the results below and in Table 7 of the main test plan. The operating modes, as given in the operating manual for the Navalis Orion[®] system, and details to be tested are included in Table C-2.

Table C-2. Test 1-25, Operating Modes

Operation Mode	Mode Requirement	Success Criteria and Result (Y/N)	Y/N	Comments
AUTO (normal operation)	Normal system automatic operation based on liquid levels in the collecting tank.	With circuit breaker energized, select “START” on the system status and ultra status buttons and “AUTO ENABLED” located on the main screen of the operator interface and achieve steady- state operation automatically. All manual controls are inactive.		
	Auto mode: Idle	When the liquid level in the shaker tank is low (low level indicator PT1 < 25%), the system stops processing and the system waits for water to be fed to the system. and a message is displayed on the operator interface.		
Off	Unit is turned off automatically without damage to the system.	When the “STOP” on the system status button is pressed on the main screen of the operator interface, the unit stops operation without damage and a message is displayed on the operator interface.		
MAN	Operates the system without regard to the tank levels when selected.	With circuit breaker energized, select “START” on the system status and ultra status buttons located on the main screen of the operator interface and operator can troubleshoot or operate manually.		
Emergency Pump Down	Pump untreated liquid in the feed tank overboard or to shore connection.	Select “E-STOP”. Follow operation instructions for valve alignment and then follow the instructions.		
CIP (Clean-in-place)	Chemically clean the ultrafiltration membranes using the Ultrasil 76 and 110 cleaners.	Select “CIP MAIN”. Press “START” for ULTRA STATUS and CIP STATUS. System will automatically clean the membranes through the 30-step sequence.		

Test 1-26, Monitoring and Control

The performance specification requires that MSDs be capable of monitoring and automatically controlling all appropriate subsystems and operations. Specific requirements and tests required for the Navalis Orion[®] system are included in Table C-3. Record the results in this table and in Table 7 of the main test plan.

Table C-3. Test 1-26, Monitoring and Control

Monitoring and Control Requirement	Success Criteria and Result (Y/N)	Y/N	Comments
PLC and message display	A PLC or equivalent with message display and operator access to all modes of operation is provided.		
Emergency Shutdown	Check and verify that the emergency stop pushbutton on the control panel stops the system and a message is displayed.		
	Does the unit have provisions for a remote emergency stop?		
System control switch for operation modes	Do the "AUT" and "MAN" pushbuttons function properly?		
Elapsed time meter for each pump	Is the elapsed time for each pump recorded or displayed on the MSD?		
Power loss return	Does the MSD restart automatic operation upon return of power after a power failure?		
That alarm messages are read and logged for each item.	Motor thermal overload		
	Emergency stop		
	Power interrupt		
	Vent high pressure		

Test 1-27, Audible Alerts and Alarms

The procurement specification requires that certain audible alerts and alarms be provided and meet specific requirements. The specific requirements are listed in the main body of the test plan, and the specific alerts and alarms used during previous laboratory evaluations are listed in Table C-4. Test the alerts and alarms as described in Test 1-27, and record the results in this table and in Table 7 of the main test plan.

Table C-4. Test 1-27, Audible Alerts and Alarms

Audible Alert and Alarm Requirement	Success Criteria and Result (Y/N)	Y/N	Comments
Audible alerts of main test 1-27	MSD meets the requirements listed in Test 1-27 for audible alarms.		
Audible alarms of main test 1-27			
Vent high pressure alarm	Confirm the MSD has audible alarm that meets the specification requirements.		
Power loss occurred			
Emergency stop			
Inlet tank high level			

Test 1-28, Visual Alerts and Alarms

The procurement specification requires that certain visual alerts and alarms be provided and meet specific requirements. The specific requirements are listed in the main body of the test plan, and the specific Navalis Orion® system alarms and alerts are listed in Table C-5. Test the alarms and alerts as described in Test 1-28, and record the results in this table and in Table 7 of the main test plan.

Table C-5. Test 1-28, Visual Alerts and Alarms

Visual Alert and Alarm Requirement	Success Criteria and Result (Y/N)	Y/N	Comments
Visual alerts of main test 1-28	MSD meets the requirements listed in Test 1-28 for visual alerts and alarms.		
Visual alarms of main test 1-28			
Macerator motor starter trouble	Confirm the MSD has visual alarm that meets the specification requirements.		
Vent high pressure alarm			
Power loss occurred			
Emergency stop			
Inlet tank high level			

Test 1-32, Data Acquisition/Retrieval

For the phase 1 portion of the test, view the status of all saved data once per day to confirm that data is stored in accordance with Table C-6. Do not erase any data until the end of the processing test to confirm that the system can store and retrieve data for the 15-day test period. Four times during the test download the data and view it on an external computer to verify data retrieval capabilities. Record the results and comments in Table C-6 below and in Table 8 in the main test plan. These are the minimum requirements.

Table C-6. Data Acquisition/Retrieval, Test 1-32

Data Acquisition/Retrieval	Success Criteria and Result (Y/N)	Y/N	Comments
Influent Flow	Did the MSD record each parameter properly?		
Effluent Flow			
Effluent ORP			
Effluent pH			
Effluent Turbidity			
Effluent Temperature			
Membrane Reject Flow			
Membrane Product Flow			
Membrane Pressure			
Tubular Filter Effluent Flow			
Tank Levels			
Pump Pressures			
System Pressures			
System On/Off			
Level 1 Alarm			
Level 2 Motor Overload Trip			
Daily data	Was the data successfully viewed every day?		
Retrieval capabilities	Was the data successfully retrieved four times during the test as described above?		

Test 2-9, Data Acquisition/Retrieval

For the phase 2 portion of the test, view the status of all saved data once per day to confirm that data is stored in accordance with Table C-7. Do not erase any data until the end of the processing test to confirm that the system can store and retrieve data for the 15-day test period. Four times during the test download the data and view it on an external computer to verify data retrieval capabilities. Record the results and comments in Table C-7 below and in Table 10 in the main test plan. These are the minimum requirements.

Table C-7. Data Acquisition/Retrieval, Test 2-9.

Data Acquisition/Retrieval	Success Criteria and Result (Y/N)	Y/N	Comments
Influent Flow	Did the MSD record each parameter properly?		
Effluent Flow			
Effluent ORP			
Effluent pH			
Effluent Turbidity			
Effluent Temperature			
Membrane Reject Flow			
Membrane Product Flow			
Membrane Pressure			
Tubular Filter Effluent Flow			
Tank Levels			
Pump Pressures			
System Pressures			
System On/Off			
Level 1 Alarm			
Level 2 Motor Overload Trip			
Daily data	Was the data successfully viewed every day?		
Retrieval capabilities	Was the data successfully retrieved four times during the test as described above?		

Inspection Checklist

Laboratory connections to the Orion™ system

During the system inspection at the manufacturing site, check that the system connections that are provided will match with the laboratory connections. See Drawing NES-ORI05-PI00 Rev 10 in Appendix A for exact location.

Table C-8. Laboratory Connections to the Orion™ system

Laboratory Connections	Success Criteria and Result (Y/N)	Y/N	Comments
Wastewater Inlet 2" ANSI 150# Flange (DN50) at 8-C	Confirm the MSD connections match the laboratory connections		
Membrane Blowdown 2" ANSI 150# Flange (DN50) at 4-B			
Hot Technical Water Inlet 3/4" Female NPT threads (DN20) at 8-C			
Power Vent Discharge 1" ANSI 150# Flange (DN25) at 24-B			
Treated Water Discharge 3/4" ANSI 150# Flange (DN20) at 20-B			
Compressed Air Inlet 1/2" Female NPT threads (DN15) at 20-A			
Sludge Discharge 1-1/2" ANSI 150# Flange (DN40) at 25-B			
Drain Discharge 1-1/2" ANSI 150# Flange (DN40) at 25-B			

Sludge Reduction System Test

Table C-9. Sludge Reduction System Performance

Sludge Reduction	Record daily sludge tank levels	Date:	Day 1	Day 2	Day 3	Day 4	Day 5	
		Tank level, gal:						
		Date:	Day 6	Day 7	Day 8	Day 9	Day 10	
		Tank level, gal:						
Date:	Day 11	Day 12	Day 13	Day 14	Day 15			
Tank level, gal:								
Date:	Day 16	Day 17						
Tank level, gal:								

Membrane Processing Parameters

Table C-10. Recovery Rate of Ultrafiltration Process

Membrane Processing Parameters (auto log)	Record daily average flow rates (volume/hour) of membrane influent, effluent, and reject	Date:	Day 1	Day 2	Day 3	Day 4	Day 5
		Influent Flow Rate, m ³ /hr (FM 55): Effluent Flow Rate, m ³ /hr (FM 18): Reject Flow Rate, m ³ /hr (FM 19):					
		Date:	Day 6	Day 7	Day 8	Day 9	Day 10
		Influent Flow Rate, m ³ /hr (FM 55): Effluent Flow Rate, m ³ /hr (FM 18): Reject Flow Rate, m ³ /hr (FM 19):					
Date:	Day 11	Day 12	Day 13	Day 14	Day 15		
Influent Flow Rate, m ³ /hr (FM 55): Effluent Flow Rate, m ³ /hr (FM 18): Reject Flow Rate, m ³ /hr (FM 19):							
Date:	Day 16	Day 17					
Influent Flow Rate, m ³ /hr (FM 55): Effluent Flow Rate, m ³ /hr (FM 18): Reject Flow Rate, m ³ /hr (FM 19):							

Cost Analysis Parameters

Table C-11. Cost Analysis Parameters for Each Phase

Navalis Orion Laboratory Evaluation -- Cost Analysis Parameters

Mobilization	Document time to deliver system from WRI	Date shipped: Date received:
	Document cost to deliver system from WRI	Shipping cost:
Installation	Calculate total hours required to connect system in laboratory	Date: Time start: Time end: # people:
Training	Number of training hours for engineers and technicians	Date: Time start: Time end: # people:

Operation	Number of hours for engineers and technicians to operate system	Date:	Day 1	Day 2	Day 3	Day 4	Day 5
		Hours:					
		Date:	Day 6	Day 7	Day 8	Day 9	Day 10
		Hours:					
		Date:	Day 11	Day 12	Day 13	Day 14	Day 15
		Hours:					

Utilities	Record daily power used	Date:	Day 1	Day 2	Day 3	Day 4	Day 5
		KWh:					
		Date:	Day 6	Day 7	Day 8	Day 9	Day 10
		KWh:					
		Date:	Day 11	Day 12	Day 13	Day 14	Day 15
		KWh:					

Utilities	Record daily water usage	Date:	Day 1	Day 2	Day 3	Day 4	Day 5
		Source 1 gals:					
		Source 2 gals:					
		Source 3 gals:					
		Source 4 gals:					
		Date:	Day 6	Day 7	Day 8	Day 9	Day 10
Source 1 gals:							
Source 2 gals:							
Source 3 gals:							
Source 4 gals:							
Date:	Day 11	Day 12	Day 13	Day 14	Day 15		
Source 1 gals:							
Source 2 gals:							
Source 3 gals:							
Source 4 gals:							

Table C-11. Cost Analysis Parameters (cont)

Maintenance and Repair	Record daily labor required for regular maintenance items and any repair items	Date:	Day 1	Day 2	Day 3	Day 4	Day 5
		Maint hrs:					
		Description:					
		Repair hrs:					
		Description:					
		Date:	Day 6	Day 7	Day 8	Day 9	Day 10
		Maint hrs:					
		Description:					
		Repair hrs:					
Date:	Day 11	Day 12	Day 13	Day 14	Day 15		
Maint hrs:							
Description:							
Repair hrs:							
Description:							
Consumables	Record amount of consumable used daily	Date:	Day 1	Day 2	Day 3	Day 4	Day 5
		Flocculant, gals:					
		Ultrasil 76, gals:					
		Ultrasil 110, gals:					
		Date:	Day 6	Day 7	Day 8	Day 9	Day 10
		Flocculant, gals:					
		Ultrasil 76, gals:					
		Ultrasil 110, gals:					
		Date:	Day 11	Day 12	Day 13	Day 14	Day 15
Flocculant, gals:							
Ultrasil 76, gals:							
Ultrasil 110, gals:							
Waste Disposal	Record volume of sludge discharged	Date:	Day 1	Day 2	Day 3	Day 4	Day 5
		gals:					
		Date:	Day 6	Day 7	Day 8	Day 9	Day 10
		gals:					
		Date:	Day 11	Day 12	Day 13	Day 14	Day 15
		gals:					

Appendix D: NSWCCD Code 669 DDAM Analysis Review Memorandum

MEMORANDUM

MAY 17 2010

From: Code 669 (B. Heyburn)
To: Code 633 (T. Lerke)

Subj: REVIEW OF DDAM ANALYSIS FOR THE NAVALIS ENVIRONMENTAL
SYSTEMS, LLC ORION MODEL 5 ADVANCED WASTEWATER
PURIFICATION (AWP) SYSTEM

Ref: (a) Navalys Report NES USN7023-008 "Shock Analysis Report"
of 29 May 2009
(b) NAVSEA 0908-000-LP-3010 Rev. 1; Shock Design Criteria
for Surface Ships
(c) NRL Report 1396, "Interim Design Values for Shock
Design of Shipboard Equipment", Feb 1963
(d) DDS 072-1 (Confidential)

1. Reference (a) was forwarded to the Naval Surface Warfare Center, Carderock Division, NSWCCD Code 669 (Colts Neck) for review and comment. Reference (a) was performed as part of a risk mitigation effort during the design phase of the equipment identified in paragraphs 1a. - 1j. This letter does not constitute a recommendation for shock qualification of the equipment. However, NSWCCD Code 669 (Colts Neck) concludes that the analysis presented in reference (a) satisfactorily meets the requirements for Grade B, hull mounted shock in accordance with reference (b) using the shock spectrum defined in reference (c):

- | | | |
|----|----------------|----------------------------------|
| a. | Equipment Name | Membrane Module |
| | Drawing Number | NES-OR105-MD008 Rev - |
| | Manufacturer | Navalis Environmental LLC |
| b. | Equipment Name | Tubular Filter Module |
| | Drawing Number | NES-STD0000-TF001 Rev - |
| | Manufacturer | Navalis Environmental LLC |
| c. | Equipment Name | Hydraulic Separator Tank |
| | Drawing Number | NES-ORI05-MD003 Rev. 2BD18500200 |
| | Manufacturer | Navalis Environmental LLC |
| d. | Equipment Name | Stirred Reactor Tank |
| | Drawing Number | NES-ORI05-MD004 Rev. 5 |
| | Manufacturer | Navalis Environmental LLC |

Subj: REVIEW OF DDAM ANALYSIS FOR THE NAVALIS ENVIRONMENTAL SYSTEMS, LLC ORION MODEL 5 ADVANCED WASTEWATER PURIFICATION (AWP) SYSTEM

- e. Equipment Name Single Process Tank Module
Drawing Number NES-ORI05-MD001 Rev. -
Manufacturer Navalis Environmental LLC

- f. Equipment Name Double Process Tank Module
Drawing Number NES-ORI05-MD001 Rev. -
Manufacturer Navalis Environmental LLC

- g. Equipment Name Sludge Collection Tank
Drawing Number NES-SRT-MD001 Rev. 5
Manufacturer Navalis Environmental LLC

- h. Equipment Name Membrane Recirculation/Wash Pump
Module
Drawing Number NES-ORI05-EL400 Rev. 1
Manufacturer Navalis Environmental LLC

- i. Equipment Name Typical Vertical Pump Module
Drawing Number NES-USN7023-MD004 Rev. -
Manufacturer Navalis Environmental LLC

- j. Equipment Name Typical Ozone Pump Module
Drawing Number NES-USN7023-MD005 Rev. -
Manufacturer Navalis Environmental LLC

2. To consider the AWP equipment for official shock qualification, Code 633 shall update and resubmit reference (a) using the shock spectrum as defined in reference (d), in accordance with the shock criteria in reference (b).

3. The technical POC is NSWCCD Code 669 DDAM DAA Robert Heyburn, Code 669, Commercial (732) 866-2020, or email robert.heyburn@navy.mil and NSWCCD Code 669 John Marriott, Code 669, Commercial (732) 866-2667, DSN 443-1127, or email john.e.marriott@navy.mil.



J. Gosch

Appendix E: Naval Shock Analysis Report

Distribution of this Appendix is limited to U.S. Government Agencies only. Individuals who would like a copy should submit a request to Tina Lerke at tina.lerke@navy.mil.

Appendix F: Installation/Commissioning Details

Distribution of this Appendix is limited to U.S. Government Agencies only. Individuals who would like a copy should submit a request to Tina Lerke at tina.lerke@navy.mil.

Appendix G: Operation, Maintenance and Installation Manual

Distribution of this Appendix is limited to U.S. Government Agencies only. Individuals who would like a copy should submit a request to Tina Lerke at tina.lerke@navy.mil.

Appendix H: Environmental Safety and Health Review

From: [Phillips, Michael P CIV NSWCCD W. Bethesda, 3530](#)
To: [Lerke, Tina G CIV NSWCCD W. Bethesda, 6330](#)
Cc: [Shawer, Amy M CIV NSWCCD W. Bethesda, 3500](#); [Riggs, Sheila B CIV NSWCCD W. Bethesda, 6330](#); [Kelly, Charles M CIV NSWCCD W. Bethesda, 6330](#); [Gonell, Lety CIV SEA 05](#); [Smith, Rita L CIV NAVFAC](#); [Ness, John R CIV NAVFAC, WASHINGTON](#); [Cox, Walter G CIV NSWCCD W. Bethesda, 3530](#)
Subject: RE: Safety Review of Navalis Orion Treatment System
Date: Tuesday, March 17, 2009 15:59:19

Tina,

Having read your responses to my comments and to comments made by Amy Shaver, I am satisfied that you have adequately addressed the safety risks associated with your equipment providing you follow up with all the actions you describe below.

Thank you for your attention to these issues. I trust that you will contact the ESH Office again for your next project and I hope you will encourage your fellow employees to do the same.

In service,
Mike

Michael Phillips
(301)227-0002
Carderock Mission Project Review
Environmental, Safety, and Health Office
NSWC Carderock Division, Code 353

-----Original Message-----

From: Lerke, Tina G CIV NSWCCD W. Bethesda, 6330
Sent: Monday, March 16, 2009 14:55
To: Phillips, Michael P CIV NSWCCD W. Bethesda, 3530
Cc: Shawer, Amy M CIV NSWCCD W. Bethesda, 3500; Riggs, Sheila B CIV NSWCCD W. Bethesda, 6330; Kelly, Charles M CIV NSWCCD W. Bethesda, 6330; Gonell, Lety CIV SEA 05; Smith, Rita L CIV NAVFAC; Ness, John R CIV NAVFAC, WASHINGTON; Cox, Walter G CIV NSWCCD W. Bethesda, 3530
Subject: RE: Safety Review of Navalis Orion Treatment System

Mike,

I read your comments and questions, and my responses are provided below directly following each comment. Please let me know if you have anything further to add. I plan on addressing Amy's comments in a separate email which will follow soon.

We plan to begin testing the system on 23 March for two phases which will end during the week of 11 May 2009.

Thank you for all your help.

Best Regards,
Tina

-----Original Message-----

From: Phillips, Michael P CIV NSWCCD W. Bethesda, 3530
Sent: Monday, February 23, 2009 3:30 PM
To: Lerke, Tina G CIV NSWCCD W. Bethesda, 6330
Cc: Shawer, Amy M CIV NSWCCD W. Bethesda, 3500; Riggs, Sheila B CIV NSWCCD W. Bethesda, 6330; Kelly, Charles M CIV NSWCCD W. Bethesda, 6330; Gonell,

Lety CIV SEA 05; Smith, Rita L CIV NAVFAC; Ness, John R CIV NAVFAC
WASHINGTON; Cox, Walter G CIV NSWCCD W. Bethesda, 3530
Subject: RE: Safety Review of Naval Orion Treatment System

Tina,
I have finished my review of your test plan. Here are my
comments/questions:

It is not clear from your plan what will become of the effluent, reacted
sludge, and wash-down water that result from operation of this equipment. I
expect you have discussed this w/ Rita Smith. Describe how each of these
will be properly disposed of.

C633 - Per my phone conversation with Rita Smith (NAVFAC) on 2/24/09 and
e-mail correspondence on 3/12/09, the following plan is confirmed:

Before the test begins:

- Screen the influent graywater for metals (trace metals and mercury)
- Screen the influent blackwater for metals (trace metals and mercury)
- Obtain samples in triplicate (one sample event)
- These samples will give an indication of what level of metals could be
concentrated in the effluent or sludge after processing.

When the test begins:

- Screen the sludge for metals (trace metals and mercury)
- Screen the effluent for metals (trace metals and mercury)
- Obtain samples in triplicate (one sample event)
- The effluent and sludge will be allowed to be discharged to the lab
sewer.

The sample results are not required to discharge to the sewer, and will not
hold up the evaluation.

Wash-down water -- will not be discharged, will be recycled back into system
influent for processing

This plan has been added to the test plan.

The equipment has numerous energy sources (pressure, kinetic, electrical,
etc...) that must be controlled to allow safe operation and maintenance.
Ensure that all appropriate personnel have been trained in proper
lock-out/tag-out procedures before operating or maintaining the equipment.
Contact Walter Cox (x0139) for more information on this program.

C633 - We have regular lab reviews with Walter Cox via Mike Kelly (branch
head). I plan on contacting Walter this week to discuss.

On Page 8 you indicate that MarFloc 7835 as the flocculant. The provided
MSDS is for MarFloc 7825. Please correct the text or provide the correct
MSDS and ensure our office is aware of which product is being used. Also on
Page 8 you refer to Ecolab Ultrasil - 11, but the MSDS is for Ultrasil -
110. Please correct the text.

C633 - These were both typos which were fixed in the test plan text.
MarFloc 7825 will be used, and the MSDS provided is for MarFloc 7825.
Ultrasil 110 will be used, and the MSDS provided is for Ultrasil 110.

Page 10 indicates the vendor will deliver the wastewater to holding tanks in the NSWCCD laboratory. Ensure that spill prevention and control procedures are implemented for this facility. Contact John Ness (x0141) for more info.

C633 - I will contact John Ness to be sure all required procedures are implemented in wastewater lab (Bldg 60, Rm 175).

Page 14: Backflow prevention should be confirmed using potable water in the event the system does not effectively prevent backflow. Greywater/blackwater should not be introduced until adequate backflow prevention is confirmed using potable water.

C633 - The lab has always had a backflow preventor installed required by Carderock facilities. The backflow preventor is tested on a regular basis by Carderock facilities with the latest test completed in Jan 2009.

Tests 1-19, 1-31 and 2-8 (pages 16, 21, and 24) indicate a safety evaluation is required. This document review should not be construed as that evaluation. Schedule an inspection in advance for each of these test events.

C633 - Mike, I will call you to discuss exactly who needs to inspect the system before or during the test.

If Test 1-23 and 1-24 are physical tests (versus verification of design) then personnel involved require training. Please insert the following text in your plan: "Supervisors are responsible for ensuring that employees working on electrical equipment with voltage in excess of 50 volts and face a risk of electric shock are trained in and familiar with the safety-related work practices required by CFR1910.331 thru 1910.335 that pertain to their respective job assignments. Unqualified workers (workers who have not had previous training in avoiding the electrical hazards of working on or near exposed energized parts) shall also be trained in any other safe work practices which are necessary for their safety. The training shall be of the classroom or on-the-job type the degree of which is determined by the risk to the employee."

C633 - A safety section was added to the test plan where most of your comments are addressed. The above paragraph was added to the new safety section. Also, this test must be conducted by a certified electrician. We plan to have our certified electrician perform the test, not our engineers or technicians.

Test 1-26 (Page 19) "... in a controlled manner that does not damage the equipment or endanger personnel." Testing to determine if the equipment might endanger personnel implies that personnel might be in danger during this test. Describe what precautions will be implemented to minimize risk to personnel for this test.

C633 - This testing is performed using potable water with the vendor during the checkout period. The vendor can manipulate the programming to simulate dangerous situations and test the system response safely.

Regarding Amy Shower's comments, a tank or other volume would only be

subject to confined space regulations if the space is large enough to bodily enter. In that case, the risk is that a worker may become overwhelmed by gas or vapors and fall into the equipment. While an employee becoming overwhelmed is always a concern, an additional set of regulations applies when a confined space is present. It does not appear from Figure 1 that the equipment has such a space. Please confirm that is correct.

C633 - The tanks of the system do not have any openings large enough for entry, and most of the tanks are just too small with a volume of 45 gallons each. There are not confined spaces that are part of the treatment system being tested.

I concur that MSDSs for sodium hypochlorite and calcium hypochlorite are needed. I also endorse Amy's PPE requirements.

C633 - This section was a carryover from the original proposal which is now a few years old. The system no longer uses sodium hypochlorite or calcium hypochlorite in the treatment train. The test plan was edited to remove this.

Please provide any response to Amy's comments for clarity and my records.

C633 - An e-mail will be issued shortly to address each of Amy's comments.

In service,
Mike

-----Original Message-----

From: Lerke, Tina G CIV NSWCCD W. Bethesda, 6330
Sent: Wednesday, February 18, 2009 14:56
To: Phillips, Michael P CIV NSWCCD W. Bethesda, 3530
Cc: Shower, Amy M CIV NSWCCD W. Bethesda, 3500; Riggs, Sheila B CIV NSWCCD W. Bethesda, 6330; Kelly, Charles M CIV NSWCCD W. Bethesda, 6330; Gonell, Lety CIV SEA 05
Subject: RE: Safety Review of Navalix Orion Treatment System

Michael,

Do you have any issues or concerns with the test plan? We expect the treatment system to be delivered on Monday, 23 Feb. Testing is planned to begin on Monday, 9 March.

Regards,
Tina

-----Original Message-----

From: Lerke, Tina G CIV NSWCCD W. Bethesda, 6330
Sent: Monday, January 12, 2009 3:18 PM
To: Phillips, Michael P CIV NSWCCD W. Bethesda, 3530
Cc: Shower, Amy M CIV NSWCCD W. Bethesda, 3500; Riggs, Sheila B CIV NSWCCD W. Bethesda, 6330; Kelly, Charles M CIV NSWCCD W. Bethesda, 6330; Gonell, Lety CIV SEA 05
Subject: Safety Review of Navalix Orion Treatment System

Michael,

As we discussed this afternoon, a draft of the laboratory test plan for the

evaluation of the Naval Orion Advanced Wastewater Treatment System is attached. (I was unable to convert to pdf due to issues with Adobe.) Also, the latest schedule is included below. Please let me know if you have any questions on the test plan or any recommendations.

Best Regards,
Tina

Testing at Naval Orion -- 27-29 Jan 2009
Delivery Date -- 9 Feb 2009
Lab Setup & Checkout -- 9-13 Feb 2009
Week for Modifications -- 16-20 Feb 2009 Begin Testing -- 23 Feb 2009

Tina Lerke
Wastewater Management Branch
Environmental Quality Division
NAVSEA Carderock
(301) 227-5157
tina.lerke@navy.mil

Appendix I: Maintenance Log, Daily Flow and Analytical Data for Phase 1

Navalis Maintenance Log Phase I									
Date (2009)	Time	Operator	Maintenance Event	Comments	Completion Time			minutes	hours
14-May	0915	Buckley	Chemical Addition	Added 20 liters of Flocculant	~20 minutes		14-May	60	1.00
14-May	1415	Buckley	Checked and cleaned Shaker Screen	Cleaned debris from shaker screen by manually flushing with hot water	~40 minutes		16-May	10	0.17
16-May	545	Riggs	No ozone to SRT	Low flow volume and low pressure. Adjusted the flow to 4.5scfm and the pressure to 60psi	~10 minutes		18-May	40	0.67
18-May	1155	Riggs	Reset Motor Overload P-10 (sludge ozone pump)	Turned off power to system; Opened the electrical cabinet; reset motor and then restarted the system.	~5 minutes		19-May	15	0.25
18-May	1158	Riggs	Data Dump after power reset	Downloaded data from the data card.	~10 minutes		20-May	90	1.50
18-May	1210	Riggs	P-10 pump cavitating	Added potable water to SRT to thin sludge for easier transfer through pump. SRT increase from 23% to 34%.	~10 minutes		21-May	420	7.00
18-May	1415	Riggs	Checked and cleaned Shaker Screen	Manually sprayed shaker screen via program while inlet flow was off for 10 minutes	~15 minutes		22-May	40	0.67
19-May	1035	Riggs	Cleaned Shaker Screen	Canadian Visit; Stopped feed to the system; Set system to manual mode; Stopped the shaker screen and used hot water spray via program. Examined/cleaned screen while in place.	~15 minutes		26-May	100	1.67
20-May	0600-1100	Riggs	Adjust P-10 pressure; Pump is cavitating	Adjusted several times throughout this period	~1 hour		27-May	40	0.67
20-May	1600	Buckley	Added chemical flocculant	Added 20 liters of Flocculant	~20 minutes		30-May	60	1.00
20-May	1730	Riggs	Cleaned Shaker Screen	Sprayed screen with hot water via the manual mode (program)	~10 minutes		1-Jun	30	0.50
21-May	0600-1000	Riggs	Uploaded new programs (6 times)	Loaded different versions of the program to remove the P-3 (filter charge pump) high pressure alarm. C. Andreas assisted me through the process.	~3 hours.		2-Jun	60	1.00
21-May	1330	Riggs	CIP via manual process as written by J. McCre	Maintenance Day. Cleaned the ceramic membrane. Pumps are mislabeled on the screen/buttons. pH probes are not reading the same on each CIP screen.	2-3 hours		11-Jun	90	1.50
21-May	1400	Riggs	Cleaned Shaker Screen	Manually sprayed shaker screen via program while inlet flow was off for 20 minutes	~30 minutes		18-Jun	30	0.50
21-May	1430	Buckley/ R	Replaced filter socks	replaced filter socks with 20 micron mesh (~184 hours on used socks)	~30 minutes		23-Jun	40	0.67
22-May	0630	Riggs	Adjust P-10 pressure; Pump is cavitating	To increase pump pressure and sludge flow rate.	~10 minutes	No. days		15	
22-May	1600	Buckley	Manually drained Decant Tank	High level alarms on decant tank. Manually drained to Sludge Reservoir (lab tank).	~30 minutes	Average		75	
26-May	1115	Buckley/ R	Cleaned Shaker Screen	Scrubbed Shaker Screen with brush, nylon scraper, and rinsed. (Took pictures)	~1 hour	Minimum		10	
26-May	1315	Riggs	Adjusted P-10 valves; Reset Motor Overload	Turned off power to system; Opened the electrical cabinet; reset motor and then restarted the system. Downloaded data	~30 minutes	Maximum		420	
26-May	1530	Riggs	Adjusted P-10 valves	To increase pump pressure and ozone flow rate.	~10 minutes				

27-May	1115	Buckley	Reset Motor Overload	Turned off power to system; Opened the electrical cabinet; reset motor and then restarted the system. Ozone discharge pressure high. Downloaded data	~30 minutes				
27-May	1120	Buckley	Adjusted P-10 valves	To increase pump pressure and ozone flow rate.	~10 minutes				
30-May	0800	Riggs	Cleaned Shaker Screen	Scrubbed Shaker Screen with brush, nylon scraper, and rinsed. (Took pictures)	~1 hour				
1-Jun	1430	Buckley	Cleaned Shaker Screen	Turned off power to system; Opened the electrical cabinet; reset motor and then restarted the system. Ozone discharge pressure high. Downloaded data	~30 minutes				
2-Jun	1000	Riggs	Cleaned Shaker Screen	Turned off power to system; Opened the electrical cabinet; reset motor and then restarted the system. Ozone discharge pressure high. Downloaded data	~30 minutes				
2-Jun	1600	Buckley/ R	Replaced filter socks	New socks are larger in diameter (not a tight fit as previously used)	~30 minutes				
11-Jun	1300	Markle/ Ri	Replaced/ installed screen	Exchanged 74-mesh screen with 38-mesh (50% larger opening)	~30 minutes				
11-Jun	1400	Markle/ Ri	Diluted flocculant by 50%	Added 1 part flocculant with 1 part water (Pictures taken	~30 minutes				
11-Jun	1600	Markle/ Ri	Diluted flocculant by 25%	Added 1 part flocculant with 3 part water (Pictures taken	~30 minutes				
18-Jun	0600	Riggs	Reset Motor Overload	Turned off power to system; Opened the electrical cabinet; reset motor and then restarted the system. Ozone discharge pressure high. Downloaded data	~30 minutes				
23-Jun	0630	Riggs	Checked UV unit	Wiring is loose on the back of the unit. Tapping the unit engaged the connection. Tightened the wiring. (Noticed water leaking from the wire.)	~10 minutes				
23-Jun	1300	Riggs	Added chemical flocculant	Added 1 gallon of flocculant mixture. Chemical tank level is at 20 liters	~30 minutes				

Phase 1 Daily Flow Summary

	Date	Processed	Effluent Discharged	Sludge	AET Return	AET FEED	Total Discharged	Notes
Cold Start	5/14/09	2497	2266	319	914	4168	2585	* Cold Start (new filter socks)
Day 1	5/15/09	4919	4836	676	1715	8493	5512	
Day 2	5/18/09	4952	4582	735	2075	8228	5317	
Day 3	5/19/09	4091	4276	500	2711	8461	4776	
Day 4	5/20/09	2283	1977	511	1941	4944	2488	
Day 5	5/22/09	3478	3736	621	1979	7409	4357	
Day 6	5/26/09	2371	2118	279	1233	4424	2397	
Day 7	5/27/09	4424	4335	669	2148	8197	5004	
Day 8	5/28/09	5134	4853	621	1963	7708	5474	
Day 9	5/29/09	4939	1934	3099	1190	7679	5033	
Day 10	6/1/09	1955	1759	288	4389	7283	2047	
Day 11	6/16/09	4850	4617	489	2340	7945	5106	
Day 12	6/17/09	4243	4081	396	1928	6985	4477	
Day 13	6/18/09	2750	2981	422	1401	5635	3403	
Day 14	6/23/09	5036	4672	644	1978	8476	5316	
Day 15	6/24/09	4915	4907	530	2082	8030	5437	
	max	5134	4907	3099	4389	8493	5512	
	min	1955	1759	279	1190	4424	2047	
	average	4023	3711	699	2072	7326	4410	
	Total BW/GW Processed			60340	gallons			
	Total Effluent Discharged			55664	gallons			
	Total Sludge Discharged			10480	gallons			
	Total Process Water Used			877	gallons			

Phase 1 Analytical Results															
Number of Samples Collected	SAMPLE_ID	DATE	Time	Influent	AET	Effluent	Influent	AET	Effluent	Influent	Influent	AET	Effluent	Influent	Effluent
				Biochemical Oxygen Demand mg/l	Chemical Oxygen Demand mg/l	O/G (HEM) mg/l	Solids (Suspended) mg/l			Fecal Coliform cfu/100 mL					
0	Startup	05/14/09	2:00												
1	ORI-CS-1	05/14/09	06:00	1600		130	3100		280	160	65		1	240000	3
2	ORI-CS-11	05/14/09	10:00	1600		130	3200		300	130	710		2	240000	3
3	ORI-CS-12	05/14/09	14:00	1600		130	3100		310	110	650		2	240000	3
4	ORI-CS-13	05/14/09	14:00	1800		130	3200		300	320	650		2	240000	3
5	ORI-CS-14	05/14/09	14:00	1600		140	3200		320	410	650		2	240000	3
1	ORI-1	05/15/09	07:00	1300		140	2700		290	210	710		3		3
2	ORI-12	05/15/09	10:00	1800		100	3300		250	270	540		2		3
3	ORI-13	05/15/09	14:00	1800		91	4900		240	280	1200		1		4
4	ORI-14	05/18/09	07:00	620		100	1900		270	65	1300		2		3
5	ORI-15	05/18/09	10:00	1200		92	2400		230	60	2100		3		3
6	ORI-16	05/18/09	14:00	1200		51	2000		140	55	1900		2		3
7	ORI-17	05/19/09	07:00	1400		29	3200		90	19	1800		1		3
8	ORI-18	05/19/09	10:00	1100		28	1700		83	400	980		1		3
9	ORI-13	05/19/09	14:00	910		25	1400		80	230	570		1		3
10	ORI-19	05/20/09	07:00	1900		60	3900		150	390	2800		2		10
11	ORI-110	05/20/09	10:00	2100		80	4100		150	340	3100		2		10
12	ORI-111	05/20/09	14:00	2200		53	5800		120	420	4100		2		10
13	ORI-112	05/22/09	07:00	1600		30	4900		87	200	3800		1		3
14	ORI-113	05/22/09	10:00	990		73	4100		190	470	3200		4		3
15	ORI-114	05/22/09	14:00	1600		87	3700		230	270	2700		4		3
16	ORI-115	05/26/09	07:00	1100		120	3200		230	100	2500		7		4
17	ORI-116	05/26/09	10:00	1200		76	3200		180	200	2200		2		3
18	ORI-117	05/26/09	14:00	1700		110	3400		210	120	2200		1		4
19	ORI-118	05/27/09	08:00	750		140	3600		280	150	2600		2		9
20	ORI-119	05/27/09	10:00	900		130	3200		250	170	2400		2		3
21	ORI-120	05/27/09	14:00	1300		99	2500		203	100	1500		1		3
22	ORI-121	05/28/09	07:00	1300		52	1600		110	150	830		2		93
23	ORI-122	05/28/09	10:00	850		30	1700		120	170	850		1		23
24	ORI-123	05/28/09	14:00	1400		28	1600		100	200	830		2		3
25	ORI-124	05/29/09	07:00	1300		48	2500		97	240	1800		4		4
26	ORI-125	05/29/09	10:00	7700		58	2500		94	200	1500		2		9
27	ORI-126	05/29/09	14:00	1700		34	2700		71	740	1000		1		9
28	ORI-127	06/01/09	07:00	1600		24	3200		69	580	520		4		43
29	ORI-128	06/01/09	10:00	5600		85	5000		182	810	1100		2		2
30	ORI-129	06/01/09	14:00	7500		200	5600		346	660	1000		1		23
31	ORI-130	06/03/09	08:30	1200		130	2900		230	380	720		1	240000	3
32	ORI-131	06/03/09	10:00	1600		97	2600		170	450	1100		2	240000	3
33	ORI-132	06/03/09	14:00	1700		68	2800		120	310	1400		2	240000	3
34	ORI-133	06/04/09	07:00	960		90	2000		90	190	870		4		3
35	ORI-134	06/04/09	10:00	2200	1100	77	2900	2000	97	150	770		1		3
36	ORI-135	06/16/09	06:30	850	3200	12	900	940	69	95	440	580	3		46
37	ORI-136	06/16/09	08:30	1200	390	62	1800	900	78	300	950	520	3		43
38	ORI-137	06/16/09	12:30	1400	780	33	2400	1300	85	360	920	660	1		93
39	ORI-138	06/17/09	06:30	2200	1800	72	2800	2800	160	230	1000	1200	1		4
40	ORI-139	06/17/09	08:30	1800	1100	45	2700	2800	170	170	1100	1000	1		3
41	ORI-140	06/17/09	12:30	1900	1900	66	2800	2600	170	150	960	1000	2		3
42	ORI-141	06/18/09	08:00	1000	1700	96	2500	2100	230	33	1300	1300	1		10
43	ORI-142	06/18/09	10:15	2800	1700	130	2900	2700	200	11	1400	1500	1		24
44	ORI-143	06/18/09	12:30	2900	1900	150	3200	2500	200	50	1300	1600	1		24
45	ORI-144	06/23/09	06:30	500	850	73	620	1500	120	17	340	940	2		3
46	ORI-145	06/23/09	08:30	750	650	21	1200	1300	90	36	590	740	1		3
47	ORI-146	06/23/09	12:30	2100	2200	48	1600	2300	120	39	650	1300	1		3
48	ORI-147	06/24/09	05:30	650	400	46	1400	1600	130	170	360	780	2		3
49	ORI-148	06/24/09	08:30	840	650	30	1500	1400	100	150	350	640	1		3
50	ORI-149	06/24/09	11:30	670	540	30	1800	1400	1100	64	610	520	1		3
			GeoMean	1435	1087	62	2531	1766	150	160	1165	890	2	240000	6
			Average	1737	1304	73	2776	1884	177	232	1415	952	2	240000	12
			Maximum	7700	3200	200	5800	2800	1100	810	4100	1600	7	240000	93
			Minimum	500	390	12	620	900	69	11	340	520	1	240000	2

Appendix J: Statistical Analysis Technical Note No. 10-167-01 for Phase 1



4 March 2010

Technical Note No. 10-167-01

STATISTICAL ANALYSIS OF RESULTS FROM THE PHASE I TEST
OF THE NAVALIS WASTEWATER TREATMENT SYTEM

by

Kevin C. Burns

Introduction

Researchers at the Naval Surface Warfare Center, Carderock Division (NSWCCD) have recently conducted the first phase of testing a Navalys Orion wastewater treatment system. That is an advanced oxidation system which uses ozone, flocculation and ultraviolet light to eliminate contaminants from wastewater.

The Phase I test used mixed graywater (90%) and blackwater (10%). The average influent concentrations were required to meet NSWCCD specifications for certain contaminants to insure that the wastewater would be representative of that found aboard Navy ships. The effluent was required to meet MARPOL¹ standards. Those standards were met for some measured contaminants, but not for others during this test.

Test Methods

Both the NSWCCD performance specification and MEPC 159(55) require a minimum of forty effluent samples. For this evaluation, forty-five sample sets were obtained, three per day during fifteen days of testing. The extra samples were taken to allow for the possibility of lost

¹ Marine Environmental Protection Committee of the International Maritime Organization, Resolution MEPC.159(55), 13 October 2006.

data from broken sample bottles, analysis-laboratory errors or other causes. Influent and effluent samples were collected at the same times each day.

The Navalís system collects concentrated contaminants in a sludge tank. NSWCCD drained that tank overnight after each processing day to prevent tank overflow. They also took three sludge samples at the start of each test day to measure solids concentrations.

Five different contaminants were measure during this test:

BOD – five-day biochemical oxygen demand (mg/l),

COD – chemical oxygen demand (mg/l),

TSS – total suspended solids (mg/l),

O&G – oil and grease (mg/l),

FC – fecal coliform bacteria (mpn).

In the influent stream, NSWCCD measured BOD, COD, TSS and O&G. The effluent was measured for BOD, COD, TSS and FC. Only TSS was measured in the sludge.

Influent Contaminant Concentrations

The NSWCCD criteria for influent contaminant concentrations are designed to insure that laboratory test wastewater is comparable to shipboard waste. Standards have been set for three contaminants (BOD, TSS, O&G). NSWCCD also measured influent COD for this test. The NSWCCD performance specification requires that the average contaminant concentrations from forty influent samples fall within the ranges provided in Table 1 below. The target concentrations are the midpoints of those ranges. The last column of the table provides the measured averages from the Navalís Phase I test. All concentrations are provided in mg/l.

Table 1: Target Ranges and Measured Averages for Influent Contaminants

Contaminant	Allowable Range	Target	Test Average
BOD	530 – 1300	915	1404
COD			2669
TSS	700 – 2400	1550	1478
O&G	100 - 220	160	205

The average measured influent concentrations from this test were higher than desired for BOD, close to the target for TSS and near the upper limit of the allowable range for O&G. It is difficult to precisely control influent concentrations, and this feed was somewhat stronger than desired. However, the average BOD concentration was close enough to the allowable range that this should still be considered a reasonable test of the Navalis system.

Sample averages can be distorted by a small number of extreme observations, which might result from sampling or analysis errors. To check for such extreme observations, normal probability plots were used to assess the statistical distribution of data for each contaminant. Those plots compare the observed data to the expected values from a normal distribution. Random samples from a normal distribution should fall approximately along a straight line. Transformations can be applied to the data to check the fit of other common statistical distributions.

Figure 1 is a normal probability plot of the natural logarithms of the measured influent BOD concentrations. The data points fall along a line, so this is the appropriate transformation to apply. There are no clear outliers. The Anderson-Darling (AD) test statistic provides a formal test of the distribution fit. The p-value is much greater than .05, so there is no evidence to contradict the lognormal hypothesis. Given that the logarithms of the concentrations follow a normal distribution, the original observations follow a lognormal distribution. That is a common statistical model for contaminant concentrations. It was also found to provide reasonable fits for the other measured influent contaminants.

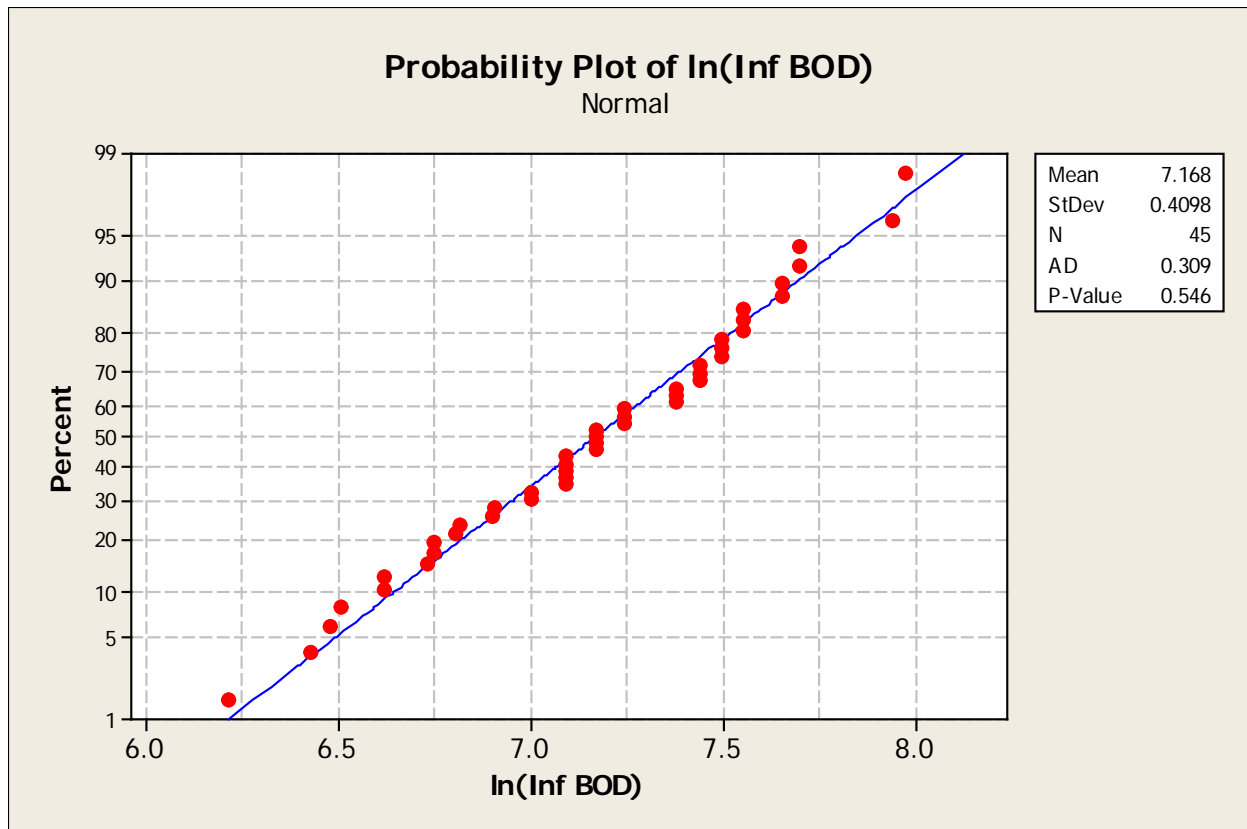

Figure 1: Check of Lognormal Fit for Influent BOD

Effluent Contaminant Concentrations

The MARPOL standards for measured effluent concentrations apply to the geometric means (GM) of those measurements. Rules are specified for calculating the GM when some observations are reported as less than the detection limit (DL). For BOD, COD and TSS, nondetects are set to DL/2. For FC, nondetects are set to 1. Table 2 provides the MARPOL standards and the measured GMs for this test, using the MARPOL rules for nondetects.

Table 2: MARPOL Standards and Measured Effluent Concentrations

Contaminant	MARPOL Standard	Measured GM
BOD	≤ 25 mg/l	60
COD	≤ 125 mg/l	145
TSS	≤ 35 mg/l	1.6
FC	≤ 100 mpn/100 ml	5.6

The measured GMs for BOD and COD exceeded the stated limits in the Phase I test.

It is possible that the failure to meet MARPOL standards for BOD and COD might be attributable to the strong wastewater feed during this test. Figure 2 is a plot of effluent versus influent BOD. There is no evidence of a correlation. Similar plots were constructed after applying various time lags to the effluent BOD to account for possible residence time. No significant correlation was found in any case. While there may still be some relationship between influent and effluent BOD, no such relationship could be found in the available data.

Figure 3 is a plot of effluent versus influent COD concentrations. The calculated correlation coefficient is .374. While not very strong, that correlation is statistically significant ($p = .011$). That is, there is clear evidence that higher influent COD concentrations will result, on average, in higher effluent COD concentrations.

There is generally some correlation between BOD and COD concentrations. Figures 4 and 5 show the relationships for this data set. The correlation is particularly strong for the effluent. That is some indication that high influent BOD concentrations might lead to high effluent BOD measurements. That is, high influent BOD implies high influent COD, which implies high effluent COD, which indicates high effluent BOD. However, this relationship is tenuous at best. In any case, the influent BOD average for this test was only about 50% over the Navy target value. The effluent GM was more than double the MARPOL limit. It seems unlikely that the system would have met the standard even with somewhat lower feed concentrations.

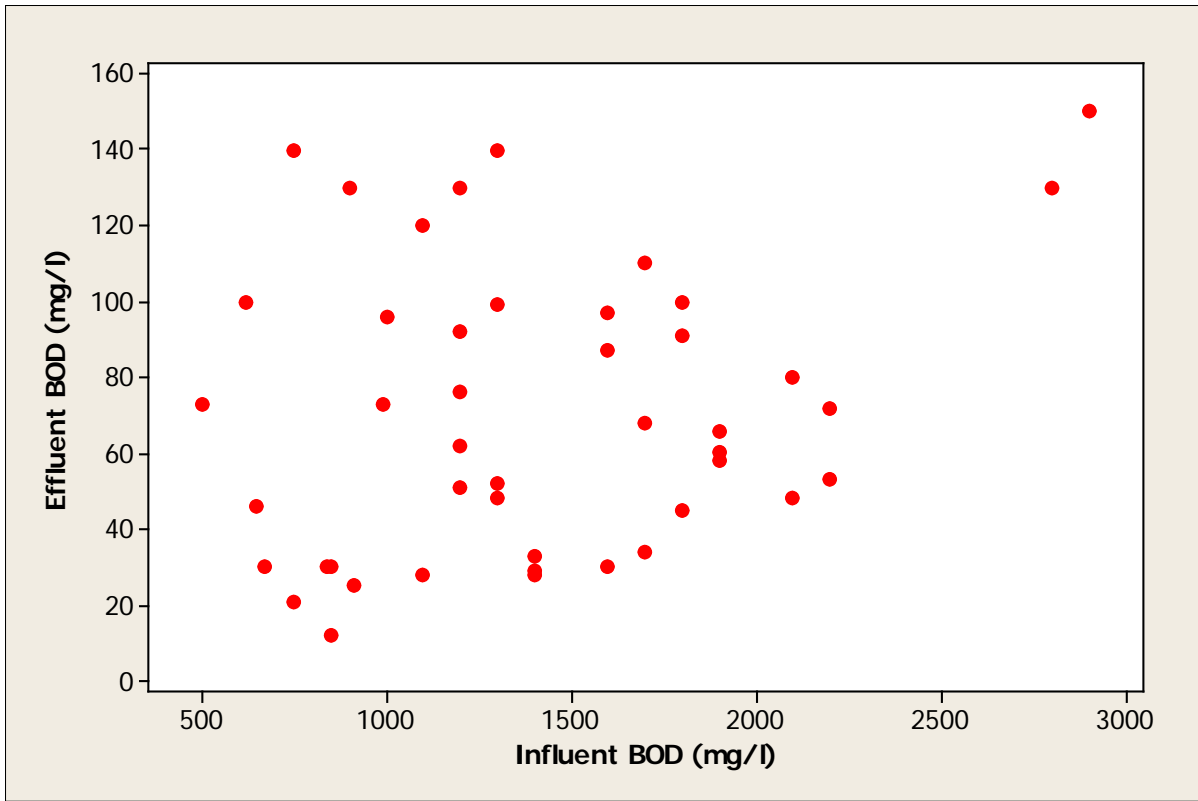

Figure 2: Effluent vs. Influent BOD Concentrations

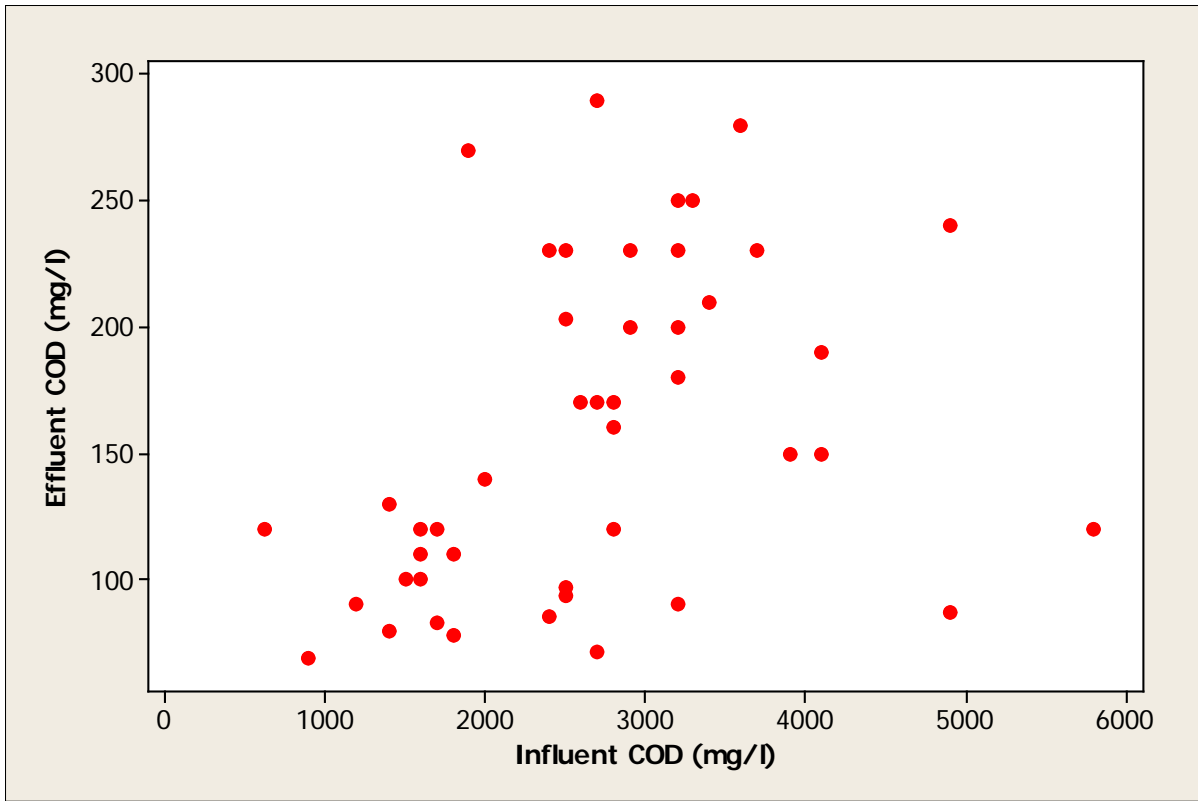

Figure 3: Effluent vs. Influent COD Concentrations

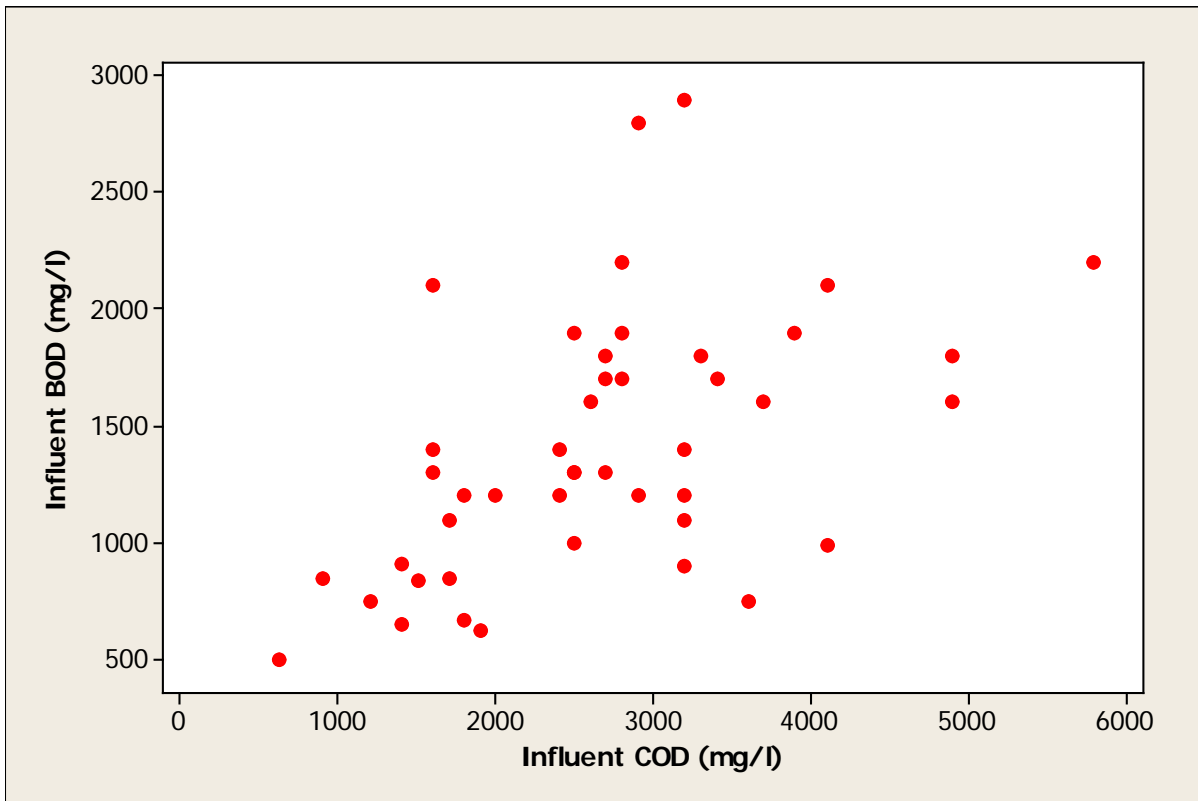

Figure 4: Influent BOD vs. COD

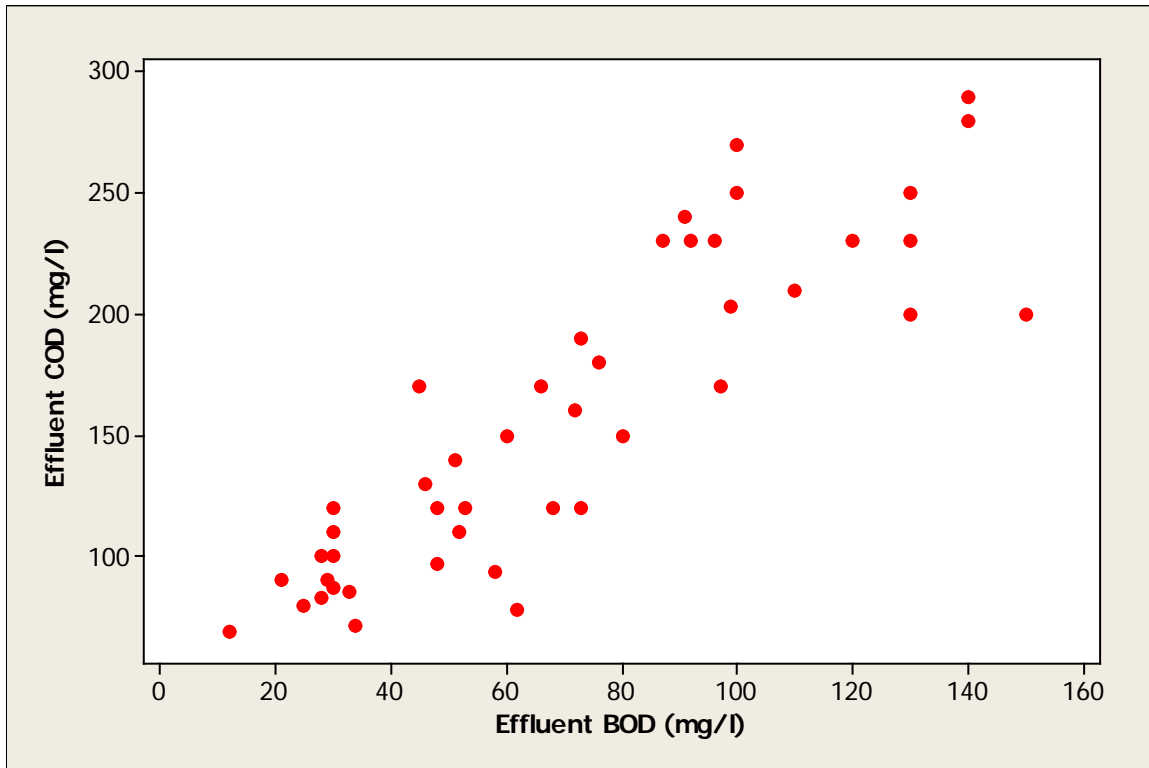

Figure 5: Effluent BOD vs. COD

Sludge Concentrations

There are no specific goals for sludge solids concentrations. These measurements were taken just to characterize the waste. Three samples were taken together at the start of each test day. As would be expected in that case, there is statistically significant variation from day to day. That is, samples taken on the same day tend to be more similar than samples taken on different days. However, since sampling was balanced, it is still reasonable to fit a distribution to the individual data points. In this case, a normal model fits well. The estimated mean is 21547 mg/l, and the estimated standard deviation is 8632 mg/l.

Conclusions

There is only one relevant conclusion to be drawn from this test. The system did not meet MARPOL standard for effluent BOD and COD. It is possible that relatively high influent BOD concentrations contributed to that failure, but it seems unlikely that the system would have passed even if the Navy influent targets had been met.

Appendix K: Maintenance Log, Daily Flow and Analytical Data for Phase 2

Navalis Maintenance Log Phase 2						Date	Minutes	Hours
Date (2010)	Time	Operator	Maintenance event	Comments	Completion Time			
23-Mar	0800	Riggs	Cleaned ceramic membrane	Removed accumulated debris from Phase I testing	~3 hours	23-Mar	187.5	3.125
23-Mar	1300	Riggs	Filled tanks with potable water	Required to start the system. Tank levels must be at least 50%. Note: Water flow rate is the restriction.	~2 hours	24-Mar	120	2
23-Mar	1400	Jones	Replaced UV Bulb	Started Phase II with a new bulb	~30 mins	25-Mar	95	1.583333
23-Mar	1430	Buckley	Installed new filter socks	Started Phase II with a new filter socks	~30 mins	29-Mar	475	7.916667
23-Mar	1500	Riggs	Added Chemical	Added 20 liters of 3:1 chemical mixture (H2O:Alum)	~15 mins	30-Mar	145	2.416667
24-Mar	0600-1600	Riggs	Adjust P-10 pressure; Pump is cavitating	Adjusted on P-10 valves throughout the day	~2 hours	31-Mar	50	0.833333
25-Mar	0500	Riggs	Drained Membrane Feed tank	To replace with potable water	~15 mins	1-Apr	70	1.166667
25-Mar	0515	Riggs	Filled Membrane Feed tank w/ potable water and flushed filter socks	To flush filter socks; Very little flow through socks	~20 mins	2-Apr	30	0.5
25-Mar	0615	Riggs	Restarted System	System was off due to several alarms and above maintenance was completed. Note: Only took seconds to engage the system, but system takes 45 minutes to drain the bottom of the hydraulic separator, intermediate tank, and flush the membrane loop before sending water through the system. All water is sent to the sludge tank or AET.	~45 mins	5-Apr	14	0.233333
25-Mar	0630	Riggs	Shutdown system, reset motor starter and restarted system	P11 (M11) drain pump motor starter tripped	~10 mins	6-Apr	14	0.233333
25-Mar	0840	Riggs	Changed filter backwash cycle	Changed frequency from every 90 secs to every 60 secs	~5 mins	8-Apr	17	0.283333
29-Mar	0600-1600	Riggs	Maintenance Day	Filter Socks clogged beyond flushing; Drained tubular canisters and replaced Filter socks	~45 mins	9-Apr	22	0.366667
29-Mar		Riggs		Drained all tanks; Solids are not separating in Hydraulic Separator	~4 hours	10-Apr	10	0.166667
29-Mar		Riggs		Checked UV system because bulb was intermittently illuminating	~30 mins	12-Apr	4	0.066667
29-Mar		Riggs		Cleaned Shaker Screen	~20 mins	13-Apr	12	0.2
29-Mar		Riggs		Changed chemical mixture to 2:1 as recommended by Navalis	~20 mins	14-Apr	10	0.166667
29-Mar		Riggs		Filled all tanks to 50% level	~2 hours	15-Apr	22	0.366667
30-Mar	0600	Riggs	Started system	Restarted Phase II; Initial start-up takes 45 mins.	~45 mins	16-Apr	14	0.233333
30-Mar	0800	Riggs	Shutdown system	Low Flow through filter socks	~5 mins	19-Apr	30	0.5

30-Mar	0810	Riggs	Removed and cleaned filter socks	Filter Socks clogged; Drained tubular canisters and cleaned Filter socks	~45 mins		20-Apr	30	0.5
30-Mar	1000	Riggs	Manually started P-2 (air dissolving pump from flocculator to hydraulic separator	Adjusting valves on flocculator tubing and P-2 to achieve negative pressure and maximum amount of air bubbles	~45 mins		21-Apr	14	0.233333
30-Mar	1050	Riggs	Restarted System		~5 mins		22-Apr	4	0.066667
31-Mar	0630	Riggs	Chemical Addition	Added 32 L of 3:1 Mixture (H2O:Alum)	~20 mins		23-Apr	14	0.233333
31-Mar	1130	Riggs	Chemical Addition	Added 10 L of 2:1 Mixture (H2O:Alum)	~10 mins				
31-Mar	1515	Riggs	Drained Sludge Tank	Provide storage tank	~20 mins	No. Days		23	
1-Apr	0630	Riggs	Chemical Addition	Added 32 L of 2:1 Mixture (H2O:Alum)	~10 mins	Average		61.02174	
1-Apr	0700	Riggs	Drained Sludge Tank	Provide storage tank	~20 mins	Minimum		4	
2-Apr	0610	Riggs	Chemical Addition	Added 37 L of 2:1 Mixture (H2O:Alum)	~20 mins	Maximum		475	
2-Apr	0800	Riggs	Checked UV	Light is not on	~10 mins				
5-Apr	0800	Riggs	Checked UV	Collected samples and UV lamp was not on	~2 mins				
5-Apr	1000	Riggs	Chemical Addition	Added 16 L of 3:1 Mixture (H2O:Alum)	~10 mins				
5-Apr	1400	Riggs	Checked UV	Collected samples and UV lamp was not on	~2 mins				
6-Apr	0830	Riggs	Chemical Addition	Added 16 L of 3:1 Mixture (H2O:Alum)	~10 mins				
6-Apr	0950	Riggs	Checked UV	Drained water from UV casings	~2 mins				
6-Apr	1030	Riggs	Checked UV	UV lamp is on!	~2 mins				
8-Apr	0730	Riggs	Adjust P-10 pressure; Pump is cavtating	P10 low pressure; adjusted gate valves to/from SRT	~2 mins				
8-Apr	0900	Riggs	Adjusted Chemical dosage	Changed chemical floc dosage from 50 strokes and 50 speed to 70 strokes/70 speed	~5 mins				
8-Apr	1200	Riggs	Chemical Addition	Added 16 L of 3:1 Mixture (H2O:Alum)	~10 mins				
9-Apr	0745	Riggs	Chemical Addition	Added 16 L of 3:1 Mixture (H2O:Alum)	~10 mins				
9-Apr	1330	Riggs	Chemical Addition	Added 16 L of 3:1 Mixture (H2O:Alum)	~10 mins				
9-Apr	1400	Riggs	Checked UV	Steady bead of water leaking from UV unit	~2 mins				
10-Apr	0615	Riggs	Chemical Addition	Added 22 L of 3:1 Mixture (H2O:Alum)	~10 mins				
12-Apr	0615	Riggs	Checked UV	Still no UV light illumination	~2 mins				
12-Apr	0740	Riggs	Primed P-3 (Intermediate Tank Pump)	Low flow through FM55. P3 vapor locked; vented to start flow	~2 mins				
13-Apr	630	Riggs	Checked UV	Still no UV light illumination; Steady drip of water exiting UV casing	~2 mins				
13-Apr	1530	Riggs	Chemical Addition	Added 16 L of 3:1 chemical floc mixture	~10 mins				
14-Apr	0715	Riggs	Chemical Addition	Added 16 L of 3:1 chemical floc mixture	~10 mins				
15-Apr	0745	Riggs	Chemical Addition	Floc tank was at low level 8 L; Added 16 L of 3:1 mixture	~10 mins				
15-Apr	1300	Riggs	Chemical Addition	Added 8 L of 3:1 mixture	~10 mins				
15-Apr	1330	Riggs	Checked UV	Vacuumed water from UV casing and the UV lamp came on	~2 mins				
16-Apr	1430	Riggs	Chemical Addition	Added 30 L of 3:1 mixture	~10 mins				

16-Apr	0730	Riggs	Checked UV	Drained water from UV casing and UV lamp came on	~2 mins				
16-Apr	0745	Riggs	Checked UV	Opened UV casing while system was running (leak originated from the wiper motor)	~2 mins				
19-Apr	1420	Riggs	Flushed Filter socks	Filled membrane feed tank with potable water to backwash membranes	~20 mins				
19-Apr	1540	Riggs	Chemical Addition	Added 16 L of 3:1 mixture to chem tank	~10 mins				
20-Apr	0945	Riggs	Chemical Addition	Added 24 L of 3:1 mixture to chem tank	~10 mins				
20-Apr	1530	Riggs	Drained Sludge Tank	Drained sludge tank of 1000 gallons	~20 mins				
21-Apr	0900	Riggs	Chemical Addition	Added 24 L of 3:1 mixture to chem tank	~10 mins				
21-Apr	1130	Riggs	Checked UV	UV lamp came on	~2 mins				
21-Apr	1330	Riggs	Checked UV	Emptied 5 L from UV leak	~2 mins				
22-Apr	0730	Riggs	Low Finish Tank Alarm	Restart system; UV lamp did not come on	~2 mins				
22-Apr	930	Riggs	Checked UV	UV lamp on	~2 mins				
23-Apr	0715	Riggs	Low Finish Tank Alarm	Restarted System	~2 mins				
23-Apr	0730	Riggs	Ozone generator tripped	system alarm due to ozone contactor tripped. Reset relay by powering down the system. Restarted system	~5 mins				
23-Apr	0740	Riggs	Force more water to transfer to reactor	Finish tank at 1% (low volume); opened reactor valve and closed AET valve on the ULTRA screen.	~5 mins				
23-Apr	0930	Riggs	Checked UV	No UV light	~2 mins				

Phase 2 Daily Flow Summary

	Date	Processed	Effluent Discharged	Sludge	AET Return	AET FEED	Total Discharged	Notes
Cold Start	4/28/10	733	420	184	1466	2966	604	Cold Start (used filter socks)
Day 1	3/24/10	966	873	118	1534.6	3172.5	991	
Day 2	3/25/10	677	240	191	839.4	880.5	431	
Day 3	3/30/10	2478	1686	307	1669	4252	1993	
Day 4	3/31/10	3126	2507	510	3079	7142	3017	
Day 5	4/1/10	3108	2572	318	2678	7301	2890	
Day 6	4/2/10	1730	1652	205	3216	7881	1857	
Day 7	4/5/10	1870	1605	233	3236	7125	1838	
Day 8	4/6/10	1568	1287	211	3526	9012	1498	
Day 9	4/7/10	1477	1256	207	3510	7790	1463	
Day 10	4/8/10	1850	1557	204	3154	6981	1761	
Day 11	4/10/10	1703	1329	286	2947	5889	1615	
Day 12	4/12/10	1044	502	368	3642	5415	870	
Day 13	4/13/10	1380	885	444	4469	7174	1329	
Day 14	4/14/10	855	536	384	4327	6435	920	
Day 15	4/15/10	695	363	375	3815	5169	738	
Day 16	4/16/10	434	193	165	1451	2211	358	Only Processed 8 hours
Day 17	4/19/10	1264	498	400	4201	6082	898	
Day 18	4/20/10	1299	700	424	4306	6366	1124	
Day 19	4/21/10	784	271	271	2606	3819	542	
Day 20	4/22/10	619	153	183	1262	1901	336	
Day 21	4/23/10	505	184	119	1408	1767	303	Only Processed 8 hours
	max	3126	2572	510	4469	9012	3017	excluded 8 hour days
	min	619	153	118	839	881	336	excluded 8 hour days
	average	1500	1077	297	3054	5778	1374	excluded 8 hour days
	Total Blackwater Processed			29432	gallons			
	Total Effluent Discharged			20832	gallons			
	Total Sludge Discharged			5923	gallons			
	Total Processed Water			1090	gallons			

Phase 2 Analytical Results																	
Number of Samples Collected	SAMPLE_ID	DATE	Time	Influent	AET	Perm	Effluent	Influent	AET	Perm	Effluent	Influent	AET	Influent	AET	Perm	Effluent
				Biochemical Oxygen Demand				Chemical Oxygen Demand				Oil&Grease (HEM)		Solids (Suspended)			
				mg/l				mg/l				mg/l		mg/l			
1	BW ORI-156	28-Apr-10	6:30	5100	4900	51	49	5500		63	54		83	4300		4	4
2	BW ORI-157	28-Apr-10	10:30	2000	3400	50	32	3200		54	41		68	2700		1	14
3	BW ORI-158	28-Apr-10	14:00	2200	2000	41	25	3900		81	23		88	2700		5	18
4	BW ORI-159	28-Apr-10	14:00	2800	2200	43	70	3000		140	34		88	2700		3	18
5	BW ORI-160	28-Apr-10	14:00	2600	2100	30	29	3600		81	39		14	2700		5	15
1	BW ORI-101	24-Mar-10	10:30	1200		5	7	2200		19	14	5		1700			1
2	BW ORI-102	24-Mar-10	14:00	1400		5	5	2300		19	14	19		2100			1
3	BW ORI-103	25-Mar-10	14:00	750		5	5	2500		16	10			1600			4
4	BW ORI-104	30-Mar-10	13:30	520		5	5	680		23	10	5		680			1
5	BW ORI-105	31-Mar-10	7:00	500		5	5	790		41	28	21		1200			1
6	BW ORI-106	31-Mar-10	11:30	1700		5	7	2200		39	34	5		2300			1
7	BW ORI-107	31-Mar-10	14:00	1500		5	5	2100		23	30	5		1900			1
8	BW ORI-108	1-Apr-10	7:00	1700		5	5	2600		45	30	5		1900			1
9	BW ORI-109	1-Apr-10	10:30	1700		5	5	2100		36	45	13		2100			1
10	BW ORI-110	1-Apr-10	14:00	1300		5	5	2300		43	39	5		1700			1
11	BW ORI-111	2-Apr-10	7:00	1600		5	5	1800		210	160	18		1400			1
12	BW ORI-112	2-Apr-10	10:30	950		5	5	2200		70	99	5		1400			1
13	BW ORI-113	2-Apr-10	14:00	800		5	5	1500		66	66	5		1200			1
14	BW ORI-114	5-Apr-10	8:00	120		5	5	100		120	70	5		78			1
15	BW ORI-115	5-Apr-10	11:00	140		5	5	630		160	100	5		480			1
16	BW ORI-116	5-Apr-10	14:00	220		5	5	630		140	120	5		460			1
17	BW ORI-117	6-Apr-10	8:00	500		5	5	1500		140	99	5		1000			1
18	BW ORI-118	6-Apr-10	11:00	1000		5	5	1800		110	90	5		1200			1
19	BW ORI-119	6-Apr-10	14:00	1600		5	5	1600		100	92	5		1300			1
20	BW ORI-120	7-Apr-10	7:30	1100		5	5	1300		81	68	10		1100			1
21	BW ORI-121	7-Apr-10	11:00	850		5	5	1200		72	52	6		1200			1
22	BW ORI-122	7-Apr-10	14:00	900		5	5	1400		120	41	5		1200			1
23	BW ORI-123	8-Apr-10	7:30	950		5	5	1800		28	12	6		1500			1
24	BW ORI-124	8-Apr-10	10:30	850		5	5	2200		34	16	6		1600			1
25	BW ORI-125	8-Apr-10	14:00	1100		5	5	1900		36	25	5		1800			1
26	BW ORI-126	9-Apr-10	7:30	75		5	5	210		21	19	5		200			1
27	BW ORI-127	9-Apr-10	10:30	500		5	5	790		37	16	5		580			1
28	BW ORI-128	9-Apr-10	14:00	800		5	5	970		63	28	8		560			1
29	BW ORI-129	12-Apr-10	10:30	550		5	5	750		83	39	6		740			2
30	BW ORI-130	12-Apr-10	14:00	500		5	20	3100		28	43	5		980			1
31	BW ORI-131	13-Apr-10	7:00	500		5	14	1100		190	92	5		860			1
32	BW ORI-132	13-Apr-10	10:30	600		5	5	920		110	120	5		760			1
33	BW ORI-133	13-Apr-10	14:00	500	500	5	5	1100	2600	72	89	9		940	3500		1
34	BW ORI-134	14-Apr-10	7:00	1500	500	5	12	2700	3100	120	82	5	5	1500	3500		2
35	BW ORI-135	14-Apr-10	11:30	2200		5	5	2100		170	160	5	5	1600			2
36	BW ORI-136	14-Apr-10	14:00	1400	500	5	5	120	1900	210	130	5		1700	3000		1
37	BW ORI-137	15-Apr-10	7:00	650		5	10	1800		110	77	5	5	1500			3
38	BW ORI-138	15-Apr-10	10:30	1000		5	5	2300		120	83	5		1500			1
39	BW ORI-139	15-Apr-10	14:00	550	500	5	5	2000	3100	83	86	5		1500	3000		1
40	BW ORI-140	16-Apr-10	10:30	650		5	6	1700		41	68	5	5	1400			1
41	BW ORI-141	16-Apr-10	14:00	750	500	5	5	1900	2200	41	43	5		1500	3400		1
42	BW ORI-142	19-Apr-10	8:00	1700	500	5	8	1700	2100	63	52	5	5	1500	2400	1	1
43	BW ORI-143	19-Apr-10	11:30	1400	500	12	9	1500	1900	74	59	5		1500	3200	1	2
44	BW ORI-144	19-Apr-10	14:00	2000	500	5	22	1200	2100	79	83	5		1400	3100	1	2
45	BW ORI-145	20-Apr-10	7:00	4300	800	5	36	1200	2000	28	63	5	5	1200	2800	1	1
46	BW ORI-146	20-Apr-10	11:30	1200	500	5	12	1700		12	41	5		1200	2900	1	3
47	BW ORI-147	20-Apr-10	14:00	2700	50	5	9	1600		12	28	7	7	2300	3100	1	1
48	BW ORI-148	21-Apr-10	7:00	2200	95			1200	2200			5		1200	2800	1	1
49	BW ORI-149	21-Apr-10	10:30	2800	230	5	14	540	1900	92	54			1700	2500	1	2
50	BW ORI-150	21-Apr-10	14:00	2200	120	5	5	1500	1700	43	30			1500	2600	1	2
51	BW ORI-151	22-Apr-10	11:00	1500	800	5	5	1800		79	57	33	5	1600	2200	1	3
52	BW ORI-152	22-Apr-10	14:00	1100	500	13	5	1800		54	130	23	5	1500	3200	1	1
53	BW ORI-154	23-Apr-10	14:00	1300	500	5	5	1600		110	81	15	5	1200	2600	1	2
54	BW ORI-155	23-Apr-10	14:00	950	2200	5	5	2200		220	97	20	5	1800	2300	1	1
			No. Samples	54	18	53	53	54	12	53	53	51	11	54	18	13	53
			GeoMean	926	406	5	6	1333	2194	60	50	7	5	1182	2868	1	1
			Average	1167	544	5	7	1564	2233	78	63	8	5	1324	2894	1	1
			Maximum	4300	2200	13	36	3100	3100	220	160	33	7	2300	3500	1	4
			Minimum	75	50	5	5	100	1700	12	10	5	5	78	2200	1	1

Appendix L: Statistical Analysis Technical Note No. 10-167-02 for Phase 2



17 June 2010

Technical Note No. 10-167-02

STATISTICAL ANALYSIS OF RESULTS FROM THE PHASE 2 TEST
OF THE NAVALIS WASTEWATER TREATMENT SYSTEM

by

Kevin C. Burns

Introduction

During March and April 2010, researchers at the Naval Surface Warfare Center, Carderock Division (NSWCCD) conducted the second phase of testing a Naval Orion wastewater treatment system. That system uses screening and hydraulic separation to remove solids which are sent to a sludge tank. The clarified liquid is then pumped through ultra-filtration membranes and given final treatment in an advanced oxidation loop using ozone and ultraviolet light.

The Phase 1 test of this system used mixed graywater (90%) and blackwater (10%). Results from that test were discussed in an earlier technical note². The Phase 2 test used blackwater alone. For these tests, average feed concentrations for certain contaminants are required to meet NSWCCD specifications. The effluent is required to meet MARPOL³ standards.

For the Phase 2 test, the average measured feed BOD concentration is close to the midpoint of the range given in the performance specification. The average feed TSS concentration is lower than required by the specification, but still high enough that this can

² Burns, Kevin C., "Statistical Analysis of Results from the Phase 1 Test of the Naval Wastewater Treatment System," SAIC Technical Note No. 10-167-01, 10 March 2010.

³ Marine Environmental Protection Committee of the International Maritime Organization, Resolution MEPC.159(55), 13 October 2006.

probably be considered a valid test of the system. The MARPOL effluent standards were met for all contaminants.

Test Methods

Both the NSWCCD performance specification and MEPC 159(55) require a minimum of forty effluent samples. For this evaluation, fifty-five sample sets were obtained during twenty-one days of testing. The extra samples were taken to allow for the possibility of lost data from broken sample bottles, analysis-laboratory errors or other causes. Samples were collected from the feed, membrane permeate and system effluent. In most cases, samples were collected from all three locations at the same time. Beginning on the third day of testing, a single sludge sample was collected each day.

Five different contaminants were measured during this test:

BOD – five-day biochemical oxygen demand (mg/l),

COD – chemical oxygen demand (mg/l),

TSS – total suspended solids (mg/l),

O&G – oil and grease (mg/l),

FC – fecal coliform bacteria (mpn/100 ml).

In the feed, NSWCCD measured BOD, COD, TSS and O&G. The membrane permeate was measured for BOD and COD. TSS samples were obtained from the permeate during the last week of testing. The effluent was measured for BOD, COD, TSS and FC. TSS and metals were measured in the sludge, but only TSS is considered in this analysis.

Influent Contaminant Concentrations

The NSWCCD criteria for influent contaminant concentrations are designed to insure that laboratory test wastewater is comparable to shipboard waste. Standards have been set for BOD and TSS in blackwater feed. NSWCCD also measured feed COD and O&G for this test, and those results are of interest as well.

The first step in this analysis was to check for suspect data points. Figure 1 is a normal probability plot of the feed BOD measurements. The majority of the data points fall between 500 mg/l and 3000 mg/l. There are four low outliers: all three samples from 5 April and the first sample from 9 April. There was one anomalously high result from the first sample taken on 20

April. It is impossible to be certain that these results are erroneous, but they do not appear to be consistent with the rest of the data, and they were not used in the analysis. No obvious outliers were identified for the other three feed contaminants.

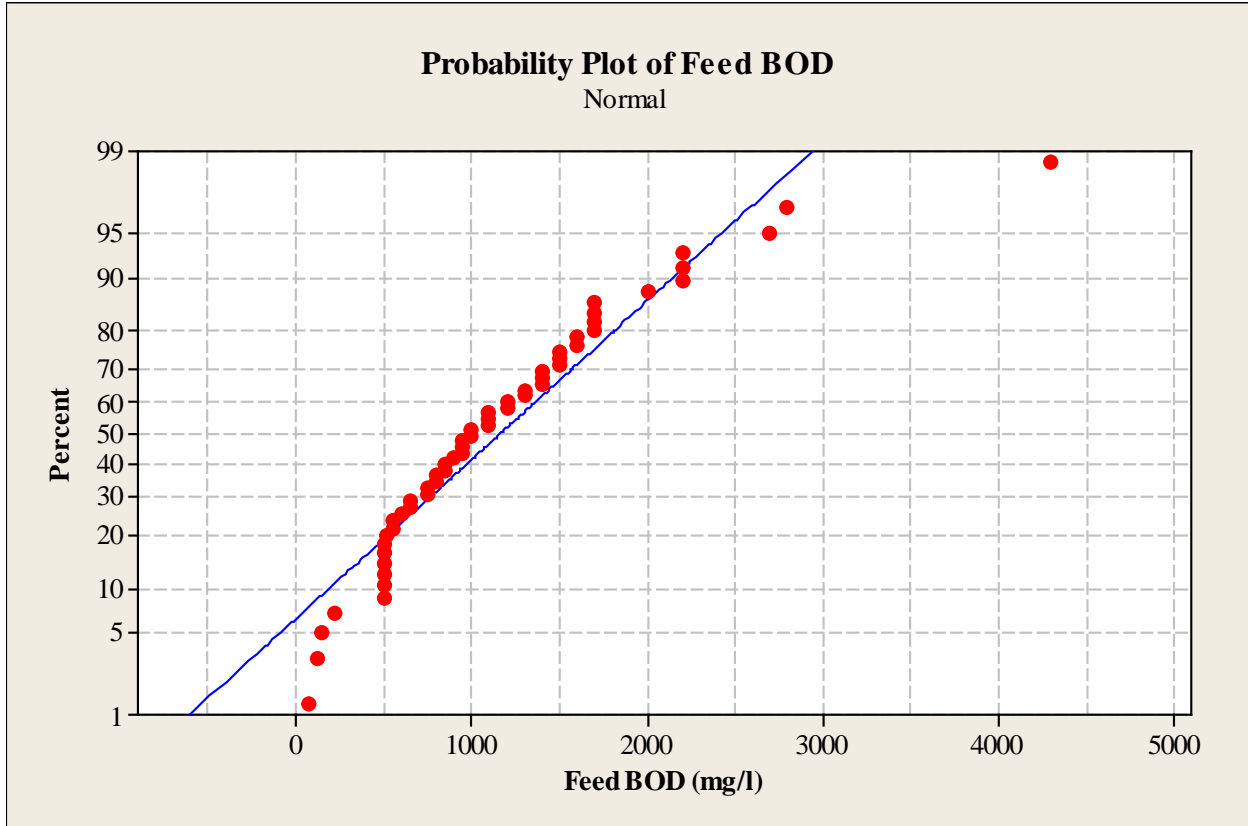

Figure 1: Normal Probability Plot for Feed BOD

The NSWCCD performance specification requires that the average contaminant concentrations from forty influent samples fall within the ranges provided in Table 1 below. The target concentrations are the midpoints of those ranges. The last column of the table provides the measured averages from the Navalis Phase 2 test. All concentrations are provided in mg/l.

Table 1: Target Ranges and Measured Averages for Feed Contaminants

Contaminant	Allowable Range	Target	Test Average
BOD	780-1700	1240	1187
COD			1579
TSS	2100-3500	2800	1324

O&G			< 8
-----	--	--	-----

The measured average feed BOD concentration is close to the performance specification target. The average TSS concentration is lower than desired and outside the performance specification range. However, TSS concentrations were probably still high enough to provide a reasonable test of the system. It should be noted that the MARPOL requirement for feed TSS is that the average must exceed 500 mg/l.

Effluent Contaminant Concentrations

The MARPOL standards for measured effluent concentrations apply to the geometric means of those measurements. Rules are specified for calculating the geometric mean when some observations are reported as less than the detection limit (DL). For BOD, COD and TSS, nondetects are set to DL/2. The analysis laboratory provided detection limits of 5 mg/l for BOD, 10 mg/l for COD and 1 mg/l for TSS. For FC, nondetects are set to 1. Table 2 provides the MARPOL standards and the measured geometric means for this test, using the MARPOL rules for nondetects.

Table 2: MARPOL Standards and Measured Effluent Concentrations

Contaminant	MARPOL Standard	Measured Geometric Mean
BOD	≤ 25 mg/l	4 mg/l
COD	≤ 125 mg/l	49 mg/l
TSS	≤ 35 mg/l	1 mg/l
FC	≤ 100 mpn/100 ml	1 mpn/100 ml

BOD and TSS were detected only occasionally in the effluent during this test. FC was not detected in any effluent sample. Measurable COD was found in most effluent samples, but the geometric mean for that contaminant is still well below the MARPOL limit.

Sludge TSS Concentrations

There are no specific goals for sludge solids concentrations. These measurements were taken just to characterize the waste. A single TSS sample was taken on each of eighteen test days. A normal probability plot of those results is provided in Figure 2. There are two obvious outliers. Very low TSS results were reported on 13 April and 14 April. Those results were discarded. The remaining data points are approximately normally distributed with an estimated mean of 19412 mg/l and an estimated standard deviation of 4691 mg/l.

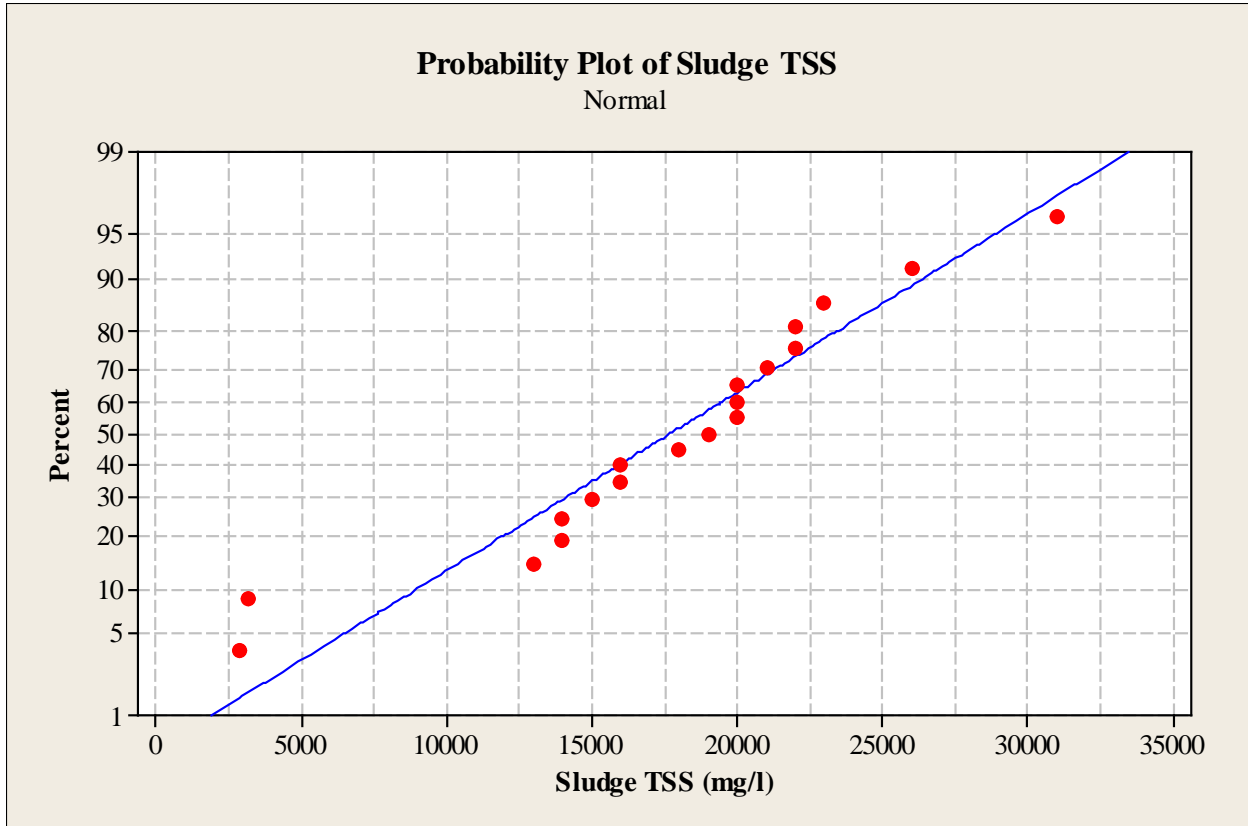

Figure 2: Normal Probability Plot for Sludge TSS

Further Discussion

For this evaluation, NSWCCD diluted surrogate raw blackwater to create the feed, which was then pumped to an aerated equalization tank (AET) before being processed by the Navalis system. Some sampling was conducted at each of five stages in the process: raw blackwater, feed, AET, membrane permeate and system effluent. The feed and effluent results are of primary interest because they are required to meet NSWCCD and MARPOL specifications, but results from other stages of the process are also important.

Table 3 provides the average and geometric mean for each contaminant measured at each sampling location. The averages are probably the most appropriate summary statistics for locations with high contaminant concentrations (raw blackwater, feed, AET). The geometric means are better summary statistics for the permeate and effluent.

In addition to those outliers identified earlier for feed BOD and sludge TSS, one very low result (first on 19 April) was discarded for AET TSS. In most cases where some results were reported as less than detection limits, the average was calculated with the nondetects set to the detection limit, and listed in Table 3 as less than the resulting value. Geometric means were calculated using the MARPOL rules for nondetects. The one exception was for BOD in the AET. For that sampling location, nine of the twenty-three BOD sample results were reported only as < 500 mg/l, which is much too high a value to be treated as a detection limit.

Wastewater contaminant concentrations tend to be skewed, with relatively low concentrations in most samples but occasional higher results. That is especially true when the contaminants are present only at low concentrations, such as in treatment system effluent. The lognormal statistical model is commonly used to fit these sample distributions. Given a skewed statistical distribution, a sample average can be distorted by the presence of a few relatively high observations. For that reason, MARPOL has chosen to base its effluent standards on geometric means of the measured concentrations. The geometric mean is the optimal estimate of the median of a lognormal distribution.

For BOD in the AET, a lognormal model provides a reasonable fit to the data. The estimated median from that model is provided in Table 3 in the geometric mean column. The estimated mean from the model is provided in the average column. Note that the sample average is an estimate of the mean for any distribution. This analysis substitutes one set of distribution parameter estimates for another set which could not be calculated from the available data.

Table 3: Summary Statistics for Each Sampling Location

Sampling Location	Contaminant	Number of Samples	Average	Geometric Mean
Raw Blackwater	BOD	16	5931	4774
	COD	16	5475	4596
	TSS	16	4318	4036
	FC	0		
	O&G	2	< 5.0	2.5
Feed	BOD	49	1187	1054
	COD	55	1579	1347
	TSS	54	1324	1182
	FC	0		
	O&G	51	< 7.7	4.2
AET	BOD	23	1117	259
	COD	17	2518	2434
	TSS	22	2800	2764
	FC	0		
	O&G	11	< 5.2	2.9
Membrane Permeate	BOD	53	< 5.3	2.7
	COD	53	79	61
	TSS	12	< 1.0	0.5
	FC	1	< 3	1
	O&G	0		
System Effluent	BOD	53	< 7.2	3.8
	COD	53	< 63	49
	TSS	53	< 1.3	0.7
	FC	53	< 3.0	1.0
	O&G	1	9	9

It is of some interest to determine how much effect the final advanced oxidation loop has on contaminant concentrations. BOD results for both the permeate and the effluent were usually reported as less than the detection limit. TSS was not detected in the permeate during the last week of testing, and was rarely detected in the effluent throughout the test. There is not enough information available to determine whether the final treatment loop had any effect on either of these contaminants.

COD was usually detected in both the permeate and the effluent, so a meaningful comparison between sample locations is possible for that contaminant. The wastewater stream has some residence time in the system between the two sample points, so samples taken at the same time from the two locations are not matched. For this analysis, it was thought best to compare daily values. The statistical distributions of COD concentrations are skewed and best fit by lognormal models. For that distribution, the best daily summary statistic is the geometric mean. For this analysis, daily geometric means were calculated using the MARPOL rule for the few observations reported as less than the detection limit.

Daily permeate COD values are plotted against the corresponding effluent values in Figure 3. The straight line on the plot is the regression fit through the origin. The estimated relationship is:

$$\text{Effluent COD} = 0.75 \text{ Permeate COD.}$$

The slope of the regression line is significantly less than one, so there is evidence that the advanced oxidation loop does reduce COD concentrations.

It would also be helpful to quantify the relationship between feed and effluent concentrations for this test. The measured feed TSS results were lower than desired. If there were a strong correlation between feed and effluent results, it might be possible to predict what effluent concentrations would have been if feed concentrations met the NSWCCD specification.

Effluent BOD and TSS concentrations were very low, usually reported as less than the detection limits. There is no clear method for estimating the relationships between feed and effluent concentrations for those contaminants. COD was usually detected in the effluent, and can perhaps be used as a proxy measure of feed strength. Daily geometric means of feed and effluent COD were calculated, again using the MARPOL rule for nondetects. The effluent values are plotted against the feed values in Figure 4. There is no statistically significant

correlation. Therefore, there is no reasonable way to estimate what would have happened if feed concentrations had been higher.

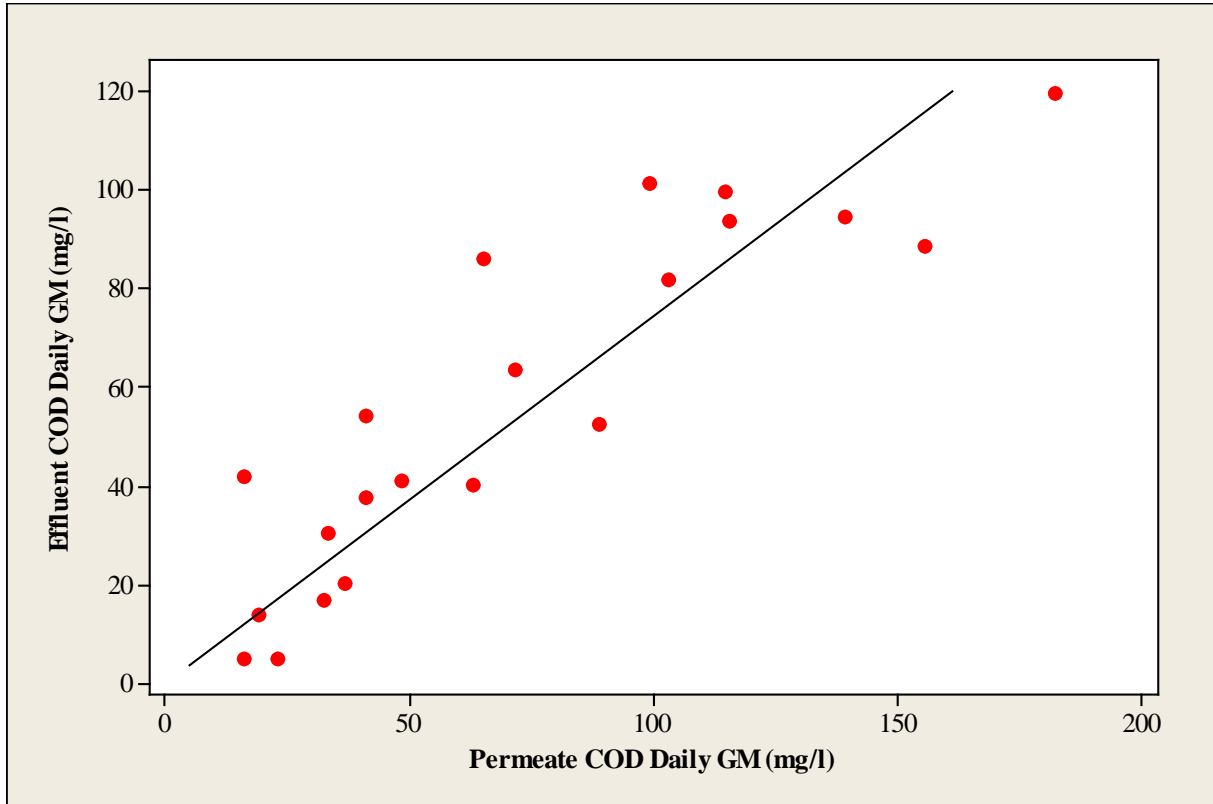

Figure 3: Effluent vs. Permeate COD Concentrations

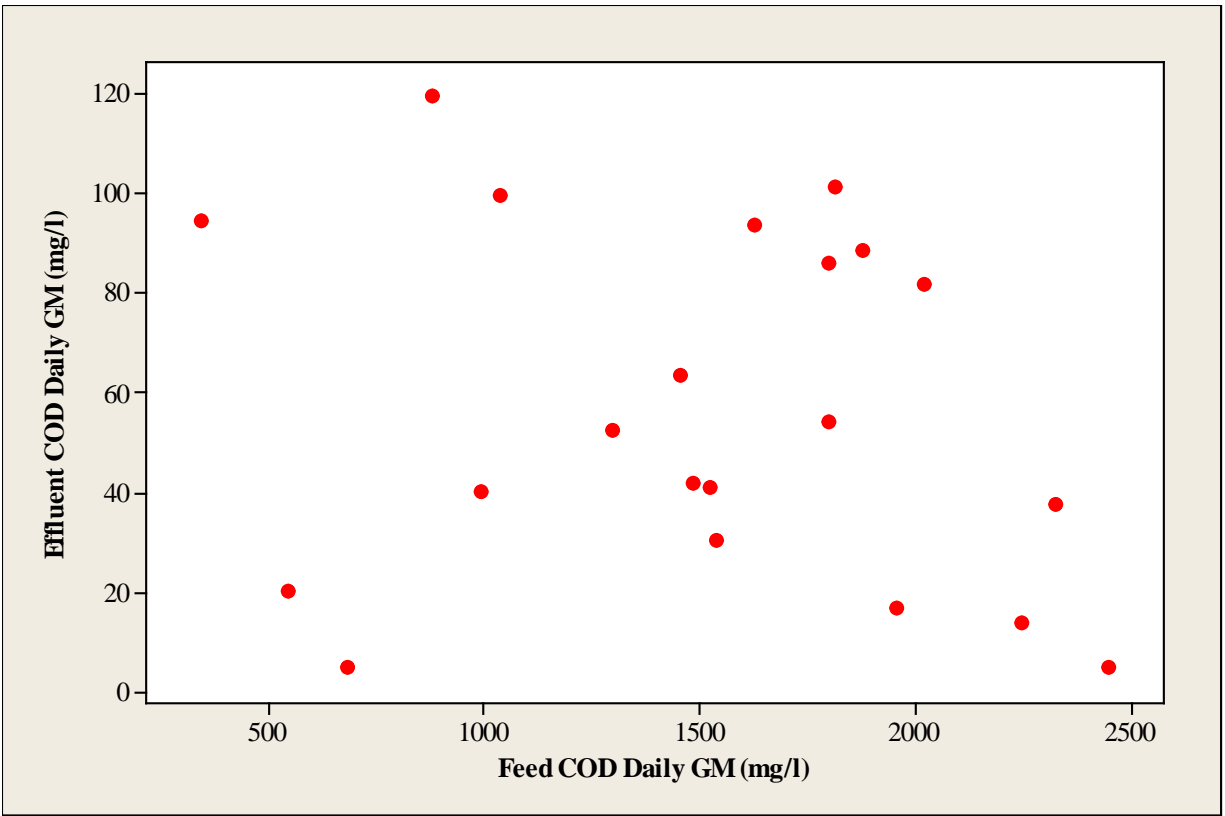

Figure 4: Effluent vs. Feed COD Concentrations

Conclusions

The average feed concentration of BOD was near the midpoint of the range required by the NSWCCD performance specification. The average feed TSS concentration was lower than required. Given the available data, it is not feasible to estimate the relationships between feed and effluent concentrations for those contaminants. Therefore, there is no way to predict what effluent concentration levels would have been if TSS feed concentrations had met the specification.

BOD, TSS and FC were rarely detected in the effluent during this test, and the estimated geometric mean concentrations are well below the MARPOL standards. COD was detected most of the time, but the calculated geometric mean is still less than half of the MARPOL limit.

Appendix M: Cost Analysis Data

Navalis Laboratory Costs			
Direct Costs		Cost, \$	Notes
Start-Up			
	Equipment Purchase	299,250	Contract amount was higher, but equipment cost was \$299,250
	Equipment Design	-	No design was needed
	Mobilization	-	Shipping cost was included in equipment cost
	Installation	2,933	Navalis install cost was included in equipment cost, C633 installation involved 3 technicians (NT-4 level) over 3 workdays \$122.21/hr (NT4) x 3 techs/day x 8 hrs/day
	Training	29,330	No formal training, hands on operation, 2 operators, ~3wks each 2 operators x \$122.21/hr x 3 wks x 40 hrs/wk
Operation & Maintenance			
	Operation (Labor)	55,728	Operation labor ~12 operator-hrs/day Phase 1 = 16 days, Phase 2 = 22 days \$122.21/hr x 12 hrs/day x (16+22)days
	Utilities	n/a	kW-hr per month + compressed air
	Waste Disposal	-	No cost, waste disposed in lab sewer
	Maintenance/Repair	37,152	Phase 1 = 15 days, Phase 2 = 23 days \$122.21/hr x 38 operator-days x 8 hrs/day
	Consumables	825	Ozone kill = 0, Ultrasil 76=\$4.50/L, Ultrasil 110=\$4.75/l, Floc chem = \$3.80/L 11.4L x \$4.5 + 11.4L x \$4.75 + 189.3L x \$3.8
Indirect Costs			
	Integrated Logistics	n/a	No special documentation needed for laboratory evaluation
	Sample Analysis	n/a	Test sampling not representative of ship
	OSHA/EHS Training	n/a	Part of employee yearly mandatory training at NSWCCD

Labor Assumptions
Operator (E-5 level, 6 yrs experience) = Hull Maintenance Technician
Supervisor (E-6 level, 10 yrs experience)
Monthly labor rate = Basic Pay + Sea Pay + Basic Allowance for Housing
E-5 Monthly Rate = 2584 + 325 + 1452 = \$ 4361 E-6 Monthly Rate = 3149 + 450 + 1452 = \$ 5051 E-5 Daily Rate = 4361/30d = \$145.37 or \$18.17/hr E-6 Daily Rate = 5051/30d = \$168.37 or \$21.05/hr
BAH assumption for Norfolk/Portsmouth, VA, 23515 (married w/dependants)
References:
2010 Active Duty Basic Pay Chart 2010 Career Sea Pay Chart
All charts from US Navy website: www.navycs.com
BAH query from DoD website: www.defensetravel.dod.mil
NSWCCD Operator (ND-4, NT-4) = \$122.21/hr

Navalis Ship Costs - Estimated				
Direct Costs				
		Cost, \$/month	Cost, \$/year	Notes
Start-Up				
	Equipment Purchase	n/a	n/a	Assume same cost. Actually would expect higher due to hardening to meet mil-specs
	Equipment Design	-	-	No design needed. Ship will purchase unit or multiple units depending on size of ship
	Mobilization	2,000	2,000	Based on Navalis, cost of shipping across US is ~\$2K
	Installation	n/a	n/a	Depends on ship layout. Each case will be different. Assume only new design ships
	Training	7,705	-	Navalis on-site training (onboard ship) 4 HT + 2 Supr + 3d course + Navalis travel + course cost 4 operators x 3 days x \$145.37/d = \$1745 2 supervisors x 3 days x \$168.37/d = \$1010 Navalis travel = \$1500, Course cost = \$1150/day x 3 days
Operation & Maintenance				
	Operation (Labor)	3,147	37,758	Est. 150 hrs/mo for E-5, 20 hrs/mo for E-6
	Utilities	1,810	21,719	14,479 kW-hr/mo x 0.125/kW-hr + compressed air (NEED INFO)
	Waste Disposal	822	9,861	Est. 1370 gal sludge/mo based on BW/GW processing BMT report \$0.5998/gal for highest rate for non-Navy port
	Maintenance/Repair	436	5,233	Screen = 2 operator x 2 hrs/wk x 4 wks/mo = \$290 Filters = 2 operator x 2 hrs/wk x 2 wks/mo = \$145
	Consumables	217	2,602	ozone media = \$500/yr wash chem 1 = 4L/mo x \$4.50/L = \$18/mo wash chem 2 = 4L/mo x \$4.75/L = \$19/mo flocculant = 24L/mo x \$3.80/L = \$91/mo PPE = \$141 per person x 4 operators = \$ 564/yr
Indirect Costs				
	Integrated Logistics	n/a		Cannot estimate without ship
	Sample Analysis	700	8,400	BOD, COD, TSS, FC analysis equipment cost = \$8400
	OSHA/EHS Training	7,200	7,200	Class = \$1200 per person, assume yearly class