

ADA

PROBABILISTIC-BASED MODELING AND SIMULATION ASSESSMENT

**INTERIM REPORT
TFLRF No. 408**

**by
W. Loren Francis
Daniel P. Nicolella
Carl F. Popelar
Ben H. Thacker**

**The Mechanical Engineering Division
Southwest Research Institute® (SwRI®)
San Antonio, TX**

**By
Allen S. Comfort
Luis A. Villahermosa**

**U.S. Army TARDEC
Force Projection Technologies
Warren, Michigan**

Contract No. DAAE-07-99-C-L053 (WD46)

Approved for public release: distribution unlimited

June 2010

Disclaimers

The findings in this report are not to be construed as an official Department of the Army position unless so designated by other authorized documents.

Trade names cited in this report do not constitute an official endorsement or approval of the use of such commercial hardware or software.

DTIC Availability Notice

Qualified requestors may obtain copies of this report from the Defense Technical Information Center, Attn: DTIC-OCC, 8725 John J. Kingman Road, Suite 0944, Fort Belvoir, Virginia 22060-6218.

Disposition Instructions

Destroy this report when no longer needed. Do not return it to the originator.

PROBABILISTIC-BASED MODELING AND SIMULATION ASSESSMENT

INTERIM REPORT
TFLRF No. 408

by
W. Loren Francis
Daniel P. Nicolella
Carl F. Popelar
Ben H. Thacker

The Mechanical Engineering Division
Southwest Research Institute[®] (SwRI[®])
San Antonio, TX

by
Allen S. Comfort
Luis A. Villahermosa

U.S. Army TARDEC
Force Projection Technologies
Warren, Michigan

Contract No. DAAE-07-99-C-L053 (WD46)
SwRI[®] Project No. 08.03227.46

Approved for public release: distribution unlimited

June 2010

Approved by:



Steven D. Marty, P.E., Director
U.S. Army TARDEC Fuels and Lubricants
Research Facility (SwRI[®])

REPORT DOCUMENTATION PAGE				<i>Form Approved</i> <i>OMB No. 0704-0188</i>	
Public reporting burden for this collection of information is estimated to average 1 hour per response, including the time for reviewing instructions, searching existing data sources, gathering and maintaining the data needed, and completing and reviewing this collection of information. Send comments regarding this burden estimate or any other aspect of this collection of information, including suggestions for reducing this burden to Department of Defense, Washington Headquarters Services, Directorate for Information Operations and Reports (0704-0188), 1215 Jefferson Davis Highway, Suite 1204, Arlington, VA 22202-4302. Respondents should be aware that notwithstanding any other provision of law, no person shall be subject to any penalty for failing to comply with a collection of information if it does not display a currently valid OMB control number. PLEASE DO NOT RETURN YOUR FORM TO THE ABOVE ADDRESS.					
1. REPORT DATE (DD-MM-YYYY) 30 June 2010		2. REPORT TYPE Interim Report		3. DATES COVERED (From - To) 08-2007 – 06-2010	
4. TITLE AND SUBTITLE Probabilistic Based Modeling and Simulation Assessment				5a. CONTRACT NUMBER DAAE07-99-C-L053	
				5b. GRANT NUMBER	
				5c. PROGRAM ELEMENT NUMBER	
6. AUTHOR(S) Francis, William L.; Nicolella, Daniel P.; Popelar, Carl F.; Thacker, Ben H. Comfort, Allen S.; Villahermosa, Luis A.				5d. PROJECT NUMBER SwRI 08.03227.46	
				5e. TASK NUMBER WD 46	
				5f. WORK UNIT NUMBER	
7. PERFORMING ORGANIZATION NAME(S) AND ADDRESS(ES) Mechanical Engineering Division Southwest Research Institute® P.O. Drawer 28510 San Antonio, TX 78228-0510				8. PERFORMING ORGANIZATION REPORT NUMBER TFLRF No. 408	
9. SPONSORING / MONITORING AGENCY NAME(S) AND ADDRESS(ES) U.S. Army RDECOM U.S. Army TARDEC Force Projection Technologies Warren, MI 48397-5000				10. SPONSOR/MONITOR'S ACRONYM(S)	
				11. SPONSOR/MONITOR'S REPORT NUMBER(S)	
12. DISTRIBUTION / AVAILABILITY STATEMENT Approved for public release; distribution unlimited					
13. SUPPLEMENTARY NOTES					
14. ABSTRACT A robust model of the HMMWV with an occupant model was created and analyzed using a variety of probabilistic methods. Methodologies were developed to determine the relative importance of structural components of the vehicle under different crash and blast scenarios. With the integration of the high fidelity neck and head model, a methodology to calculate the probability of injury to soft tissues of the neck was created and tested. These models and software tools can now be used by the Army to evaluate future designs and improve current vehicle designs in an effort to improve occupant safety on and off the battlefield.					
15. SUBJECT TERMS HMMWV, Occupant Model, Hybrid III Finite Element Model, Simulation					
16. SECURITY CLASSIFICATION OF:			17. LIMITATION OF ABSTRACT	18. NUMBER OF PAGES	19a. NAME OF RESPONSIBLE PERSON
a. REPORT Unclassified	b. ABSTRACT Unclassified	c. THIS PAGE Unclassified	Unclassified	37	19b. TELEPHONE NUMBER (include area code)

EXECUTIVE SUMMARY

Objectives

The objective of this effort is to employ probabilistic modeling and simulation to identify and explore the benefits of enhancements to improve occupant safety in U.S. Army tactical vehicles. A probabilistic-based modeling and simulation assessment will identify all key design parameters enabling improvements in design performance of existing and future tactical vehicles. The probabilistic methodology properly includes the effects of parameter variability, correlation, and multiple (often competing) failure metrics. Important scenarios include vehicular collisions, blast/fragment impact, and rollovers, as well as related hazards involving fuel and oil/fluid fires, carbon monoxide leakage, etc. The overall goal is to determine the relative importance and correlation of vehicle design factors and demonstrate how changes in these design factors can significantly increase the overall safety and survivability of occupants in both crash and non-crash scenarios. To achieve this goal the focus of this effort is divided into two areas. The first area of focus is to develop a methodology to integrate probabilistic analysis into finite element analysis of vehicle collisions and blast. The second area of focus is to develop an accurate finite element model of the occupant that can be used to determine the risk of injury.

Importance of Project

The importance of this project is to develop a model and methodology that can be used by the Army to make informed design decisions on vehicles and restraints systems that will minimize the risk of injury to the occupants. By using the probabilistic methodologies along with the high fidelity neck and Hybrid III finite element model, this approach can be applied to any vehicle in which models are available.

Technical Approach

A finite element model of the HMMWV was obtained from the Army and used to model a variety of crash and blast scenarios. For the occupant, two models were used. The first was a finite element model of the Hybrid III crash test dummy. The second was the same Hybrid III model but with the head and neck replaced with a high fidelity cervical spine and head model. The occupant models were used to determine the effects of HMMWV design changes on various injury criteria.

Accomplishments

A robust model of the HMMWV with an occupant model was created and analyzed using a variety of probabilistic methods. Methodologies were developed to determine the relative importance of structural components of the vehicle under different crash and blast scenarios. With the integration of the high fidelity neck and head model, a methodology to calculate the probability of injury to soft tissues of the neck was created and tested. These models and software tools can now be used by the Army to evaluate future designs and improve current vehicle designs in an effort to improve occupant safety on and off the battlefield.

FOREWORD/ACKNOWLEDGMENTS

The Mechanical Engineering Division of Southwest Research Institute (SwRI), San Antonio, Texas, performed this work during the period January 2007 through June 2010 under Contract No. DAAE-07-99-C-L053. The U.S. Army Tank-Automotive RD&E Center, Force Projection Technologies, Warren, Michigan administered the project. Mr. Luis Villahermosa (AMSRD-TAR-D/MS110) served as the TARDEC contracting officer's technical representative. Dr. David Tenenbaum served as project technical monitors.

The authors would like to acknowledge the TFLRF administrative and report-processing support provided by Dianna Barrera.

TABLE OF CONTENTS

<u>Section</u>	<u>Page</u>
EXECUTIVE SUMMARY	V
FOREWORD/ACKNOWLEDGMENTS	VII
LIST OF FIGURES	IX
ACRONYMS AND ABBREVIATIONS	X
1.0 INTRODUCTION AND OBJECTIVE	1
2.0 MODELING	1
2.1 HMMWV MODELING.....	1
2.2 HYBRID III MODEL	4
2.3 HIGH FIDELITY HEAD AND NECK MODEL.....	5
2.4 ANATOMICAL MODELING	7
3.0 ANALYSIS AND RESULTLS	8
3.1 BLAST LOADING.....	8
3.2 FRONTAL COLLISION	12
3.2.1 Hybrid III Model.....	12
3.2.2 High Fidelity Spine and Head Model	14
3.3 REAR COLLISION.....	16
3.3.1 Deterministic Design Optimization of Vehicle Frame Rails	19
3.4 SIDE COLLISION.....	25
4.0 CONCLUSIONS AND DISCUSSION	25

LIST OF FIGURES

<u>Figure</u>	Page
Figure 1. Finite Element Model of the HMMWV.....	2
Figure 2. Underside of the HMMWV Model Shown with the Engine and Transmission.....	3
Figure 3. Model of the Fuel Tank.....	3
Figure 4. Hybrid III Crash Test Dummy FEM.....	4
Figure 5. HMMWV FEM Shown with the Hybrid III Model Included.....	4
Figure 6. High Fidelity Head and Neck Model.....	5
Figure 7. Head displacement with only passive muscles under one gravity of loading.....	6
Figure 8. Head displacements with optimized muscles under one gravity of loading.....	6
Figure 9. The High Fidelity Head Combined with the Hybrid III FEM and Included in the HMMWV Model.....	7
Figure 10. Anatomical Surface Models Combined with an Existing Spine and Head Model.....	8
Figure 11. HMMWV model of a 0.5 kg TNT blast before detonation.....	9
Figure 12. HMMWV model 30 ms after a 0.5 kg TNT blast with von Mises stresses shown.....	9
Figure 13. CDF of the maximum displacement of the HMMWV floor.....	10
Figure 14. Importance levels for the various floor pan thicknesses and the modulus of elasticity of those components.....	11
Figure 15. HMMWV FEM with the T1 component labeled.....	11
Figure 16. Frontal 15 mph crash simulation at 100 ms with an unbelted Hybrid III model.....	12
Figure 17. HIC time history for the mean value frontal collision.....	13
Figure 18. The cumulative distribution function for HIC values in a 20 mph frontal collision...	13
Figure 19. Frontal collision simulation using the NAVAIR high fidelity cervical spine and head model.....	14
Figure 20. The seven structural components used in the mean value analysis.....	15
Figure 21. CDF for the strain in the C5-C6 intra-spinous ligament during a 15 mph frontal collision.....	15
Figure 22. A 30 mph rear impact simulation.....	16
Figure 23. Door closure distance.....	16
Figure 24. CDF for the HIC values in a 30 mph rear impact.....	17
Figure 25. Frame rail part 40611 was shown to have the greatest effect to HIC values in a rear impact.....	18
Figure 26. CDF for door closure distance in a 30 mph rear impact.....	18
Figure 27. Part 140531 was shown to have the greatest effect on door closure distance.....	19
Figure 28. Simulation of rear impact of HMMWV with a rigid wall.....	21
Figure 29. Time history of HIC during a crash event.....	21
Figure 30. Top view of an angled rear impact of a HMMWV with a rigid wall.....	22
Figure 31. Contour plot of HIC = 200 contours with confidence bounds and $\sigma_{noise} = 20$	23
Figure 32. Contour plot of HIC = 200 contours with confidence bounds and $\sigma_{noise} = 40$	24
Figure 33. Side impact model.....	25

ACRONYMS AND ABBREVIATIONS

CDF	Cumulative Distribution Function
CENTAUR	Collection of Engineering Tools for Analyzing Uncertainty
COV	Coefficient of Variation
CT	Computerized Tomography
EGO	Efficient Global Optimization
EGRA	Efficient Global Reliability Analysis
FEA	Finite Element Analysis
FEM	Finite Element Model
HIC	Head Injury Criteria
HMMWV	High Mobility Multipurpose Wheeled Vehicle
IED	Improvised Explosive Device
LSTC	Livermore Software Technology Corp.
MC	Monte Carlo
NAVAIR	Naval Air Systems Command

1.0 INTRODUCTION AND OBJECTIVE

The number of casualties and injuries that occur to war fighters as occupants in U.S. Army tactical vehicles accounts for a large portion in the overall injury and casualty numbers in the current wars in Iraq and Afghanistan. Designing vehicles and safety systems that will protect the occupant from Improvised Explosive Device (IED) blast and vehicle collisions is made difficult by often competing safety factors. While increasing armor on a vehicle will protect from blast, it will increase the risk of injury in a collision. New tools using the latest in finite element modeling, biomechanics and probabilistic analysis are need to address these challenges.

The objective of this effort is to employ probabilistic modeling and simulation to identify and explore the benefits of enhancements to improve occupant safety in U.S. Army tactical vehicles. A probabilistic-based modeling and simulation assessment will identify all key design parameters enabling improvements in design performance of existing and future tactical vehicles. The probabilistic methodology properly includes the effects of parameter variability, correlation, and multiple (often competing) failure metrics. Important scenarios include vehicular collisions, blast/fragment impact, and rollovers, as well as related hazards involving fuel and oil/fluid fires, carbon monoxide leakage, etc. The overall goal is to determine the relative importance and correlation of vehicle design factors and demonstrate how changes in these design factors can significantly increase the overall safety and survivability of occupants in both crash and non-crash scenarios. To achieve this goal the focus of this effort is divided into two areas. One being to develop a methodology to integrate probabilistic analysis into finite element analysis of vehicle collisions and blast. The second area of focus is developing an accurate finite element model of the occupant that can be used to determine the risk of injury.

2.0 MODELING

2.1 HMMWV MODELING

A finite element model of the HMMWV was obtained from TARDEC and modified for the purposes of this program, Figure 1. The model consist of 9722 solid elements, 83517 shell elements and 100259 nodes. No specific material properties were provided by the Army for the

Finite Element Model (FEM). Steel with a modulus of $2.07E11$ Pa and density of $7.83E3$ kg/m³ was used for all elements in the FEM. Welds and fasteners are modeled using nodal constraints.

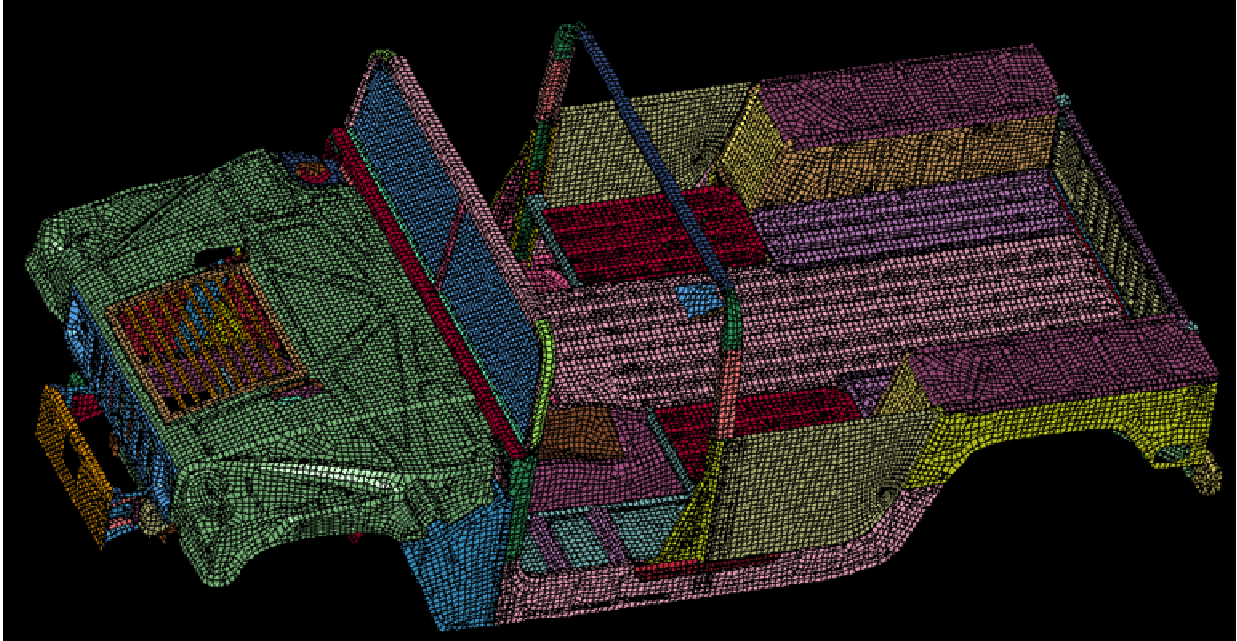

Figure 1. Finite Element Model of the HMMWV

The model as received from the Army did not include an engine or transmission. It was determined that in order to accurately model vehicle behavior during a blast or impact the weight and stiffness of the engine and transmission would be required. Using measurements taken from a HMMWV located at SwRI, a simplified model of the engine and transmission was created and added to the original HMMWV model, Figure 2. A fuel tank model was also added to give the model the capability of determining the risk of a fuel leak as the result of a collision or blast. Measurements from a HMMWV were used to create the model, Figure 3.

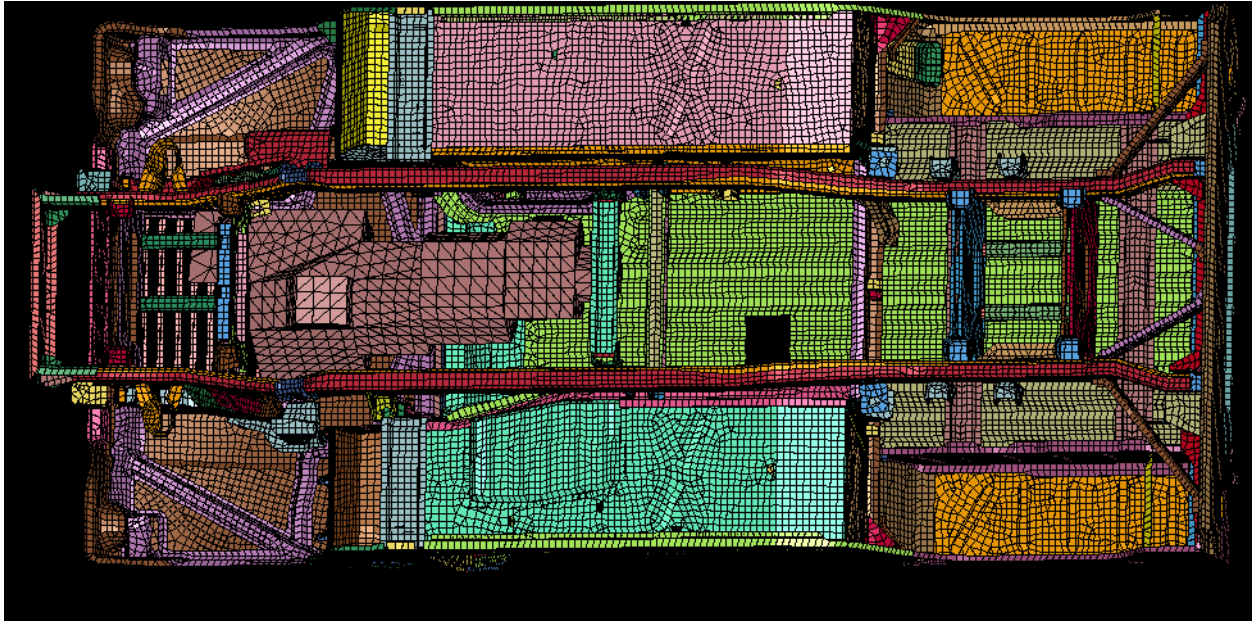

Figure 2. Underside of the HMMWV Model Shown with the Engine and Transmission



Figure 3. Model of the Fuel Tank

2.2 HYBRID III MODEL

The LSTC (Livermore Software Technology Corp.) 50th percentile Hybrid III dummy model, Figure 4, was used to add an occupant to the HMMWV model. This is a free model that has been validated for crash scenarios. The Hybrid III model consist of 4295 elements and 7444 nodes. Complete documentation for the model can be found at LSTC's website, www.lstc.com. A simplified seat structure with a three point restraint system was added to the HMMWV model along with the Hybrid III FEM, Figure 5.

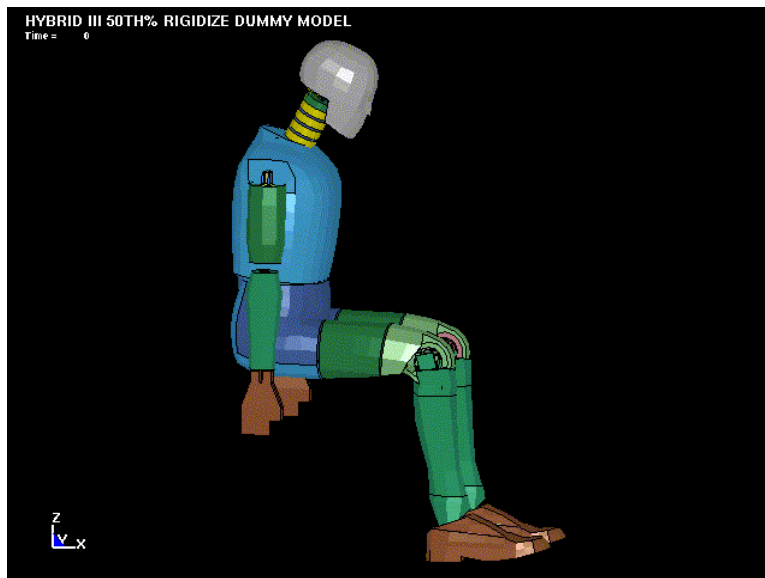

Figure 4. Hybrid III Crash Test Dummy FEM

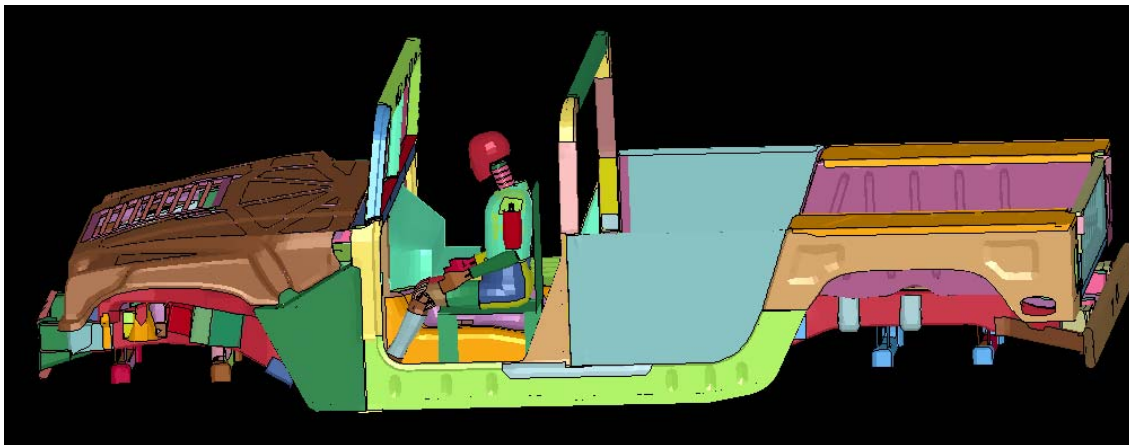

Figure 5. HMMWV FEM Shown with the Hybrid III Model Included

2.3 HIGH FIDELITY HEAD AND NECK MODEL

A high fidelity head and neck model was used to replace the simplified head and neck on the Hybrid III. The high fidelity head and neck model has the capability to output stresses and strains of soft tissue and boney structures of the head and neck. The head and neck model was originally developed for Naval Air Systems Command (NAVAIR).

The model consists of the skull through the T1 vertebrae, including the disks, ligaments and musculature, Figure 6. In total there are 57837 elements with 63713 nodes. A full description of the model can be found in Ref. [1].

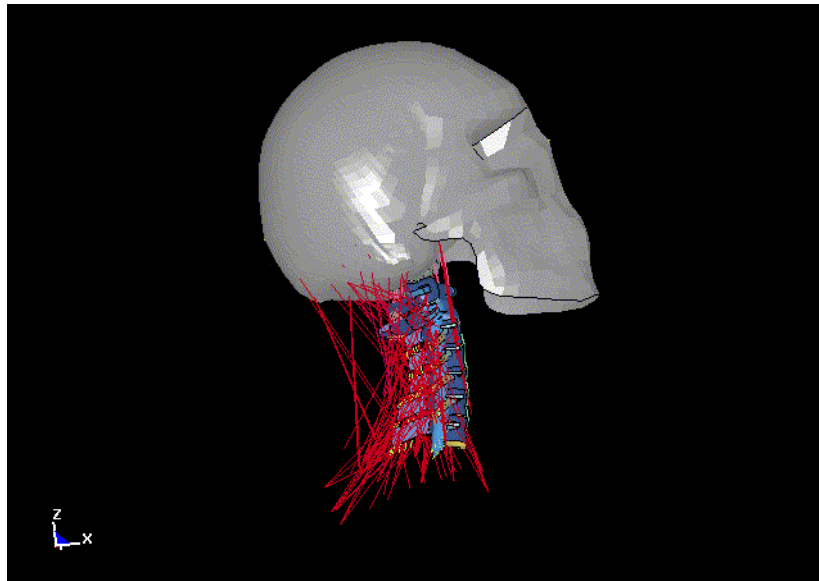

Figure 6. High Fidelity Head and Neck Model

The neck model includes 23 muscle groups modeled using Hill type muscle elements. For the purposes of these simulations it was necessary that the neck be stable in an upright position under one gravity of loading. To do this, the muscle forces had to be optimized to keep the head upright. Starting values of muscle activation levels were taken from literature (Ref. [2]) and then optimized to result in the least amount of head movement over a three second interval. With only passive musculature, the head oscillates 30 to 40 mm anterior to posterior, Figure 7. After the muscle optimization, the oscillations are reduced to less than 1.5 mm over the three seconds, Figure 8.

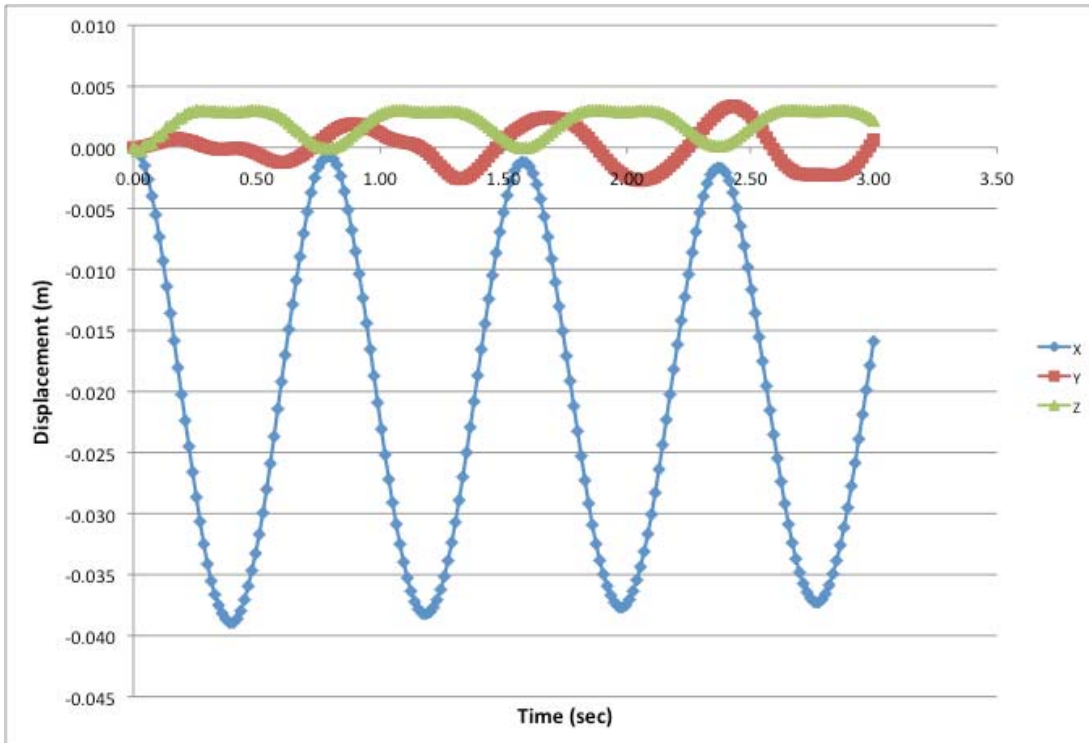

Figure 7. Head displacement with only passive muscles under one gravity of loading

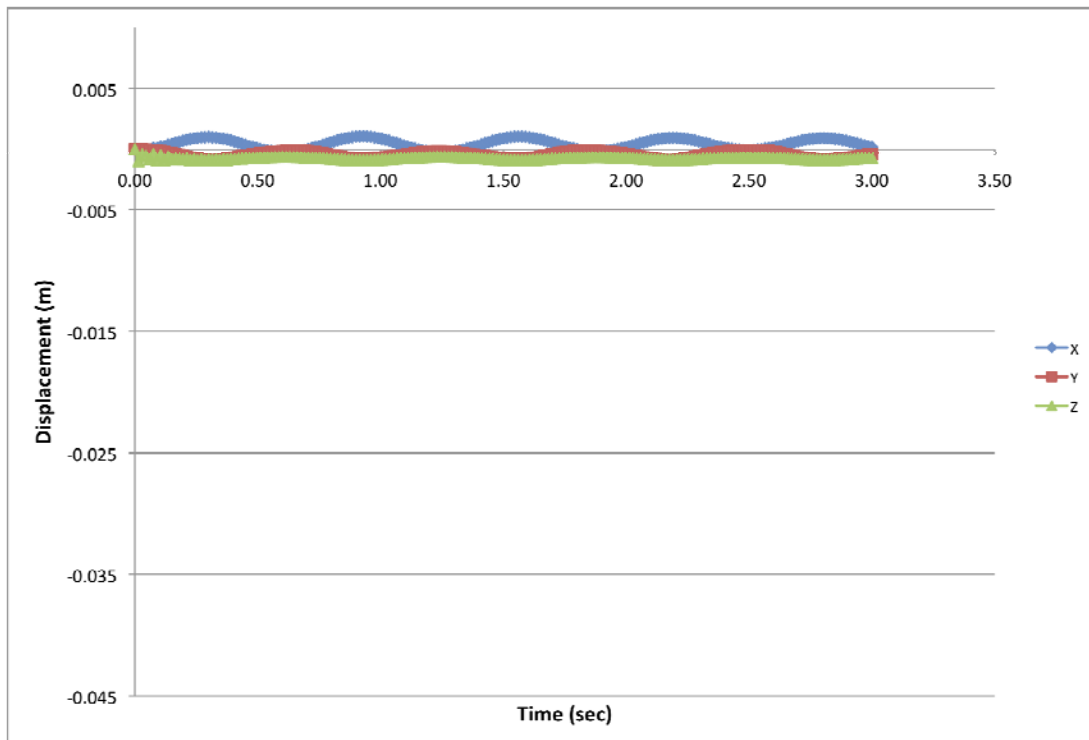

Figure 8. Head displacements with optimized muscles under one gravity of loading

The optimized high fidelity head and neck model was attached to the Hybrid III dummy model at the T1 level and included in the HMMWV model, Figure 9.

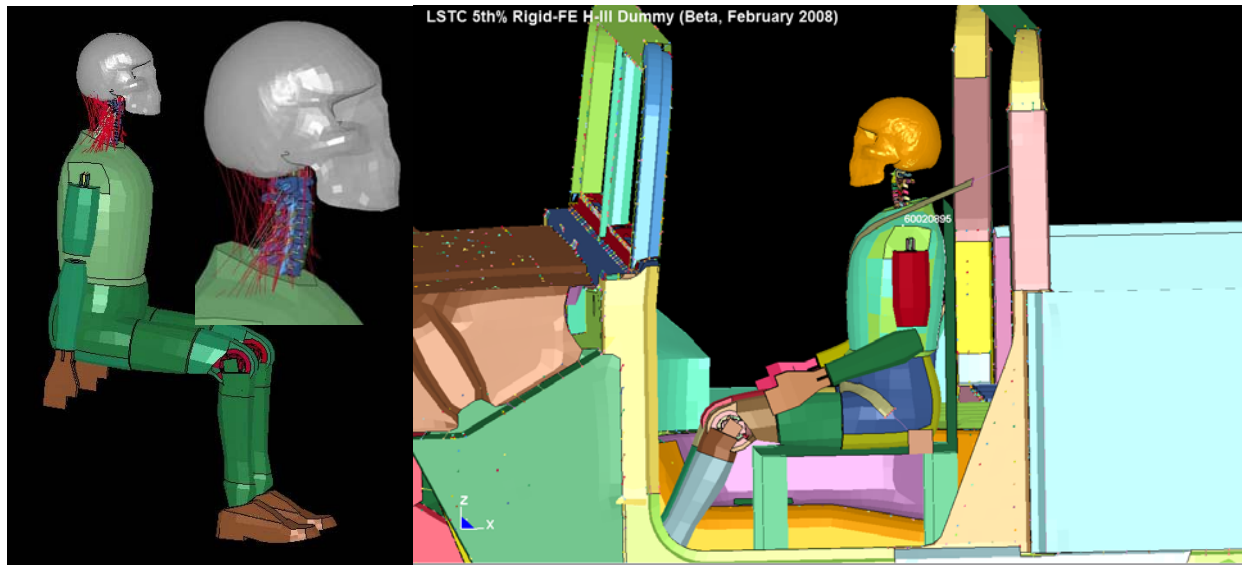

Figure 9. The High Fidelity Head Combined with the Hybrid III FEM and Included in the HMMWV Model

2.4 ANATOMICAL MODELING

Adding the high fidelity head and neck to the Hybrid III model results in the ability to determine the probability of injury to the neck. However, to determine multiple types of injuries, a more detailed model of the human body is needed. Some of the internal organs of the body were modeled using surfaces created from computerized tomography (CT) scans and added to a full spine model, Figure 10. This model is not yet complete, but when complete will allow for the measurement of a multitude of injury criteria.

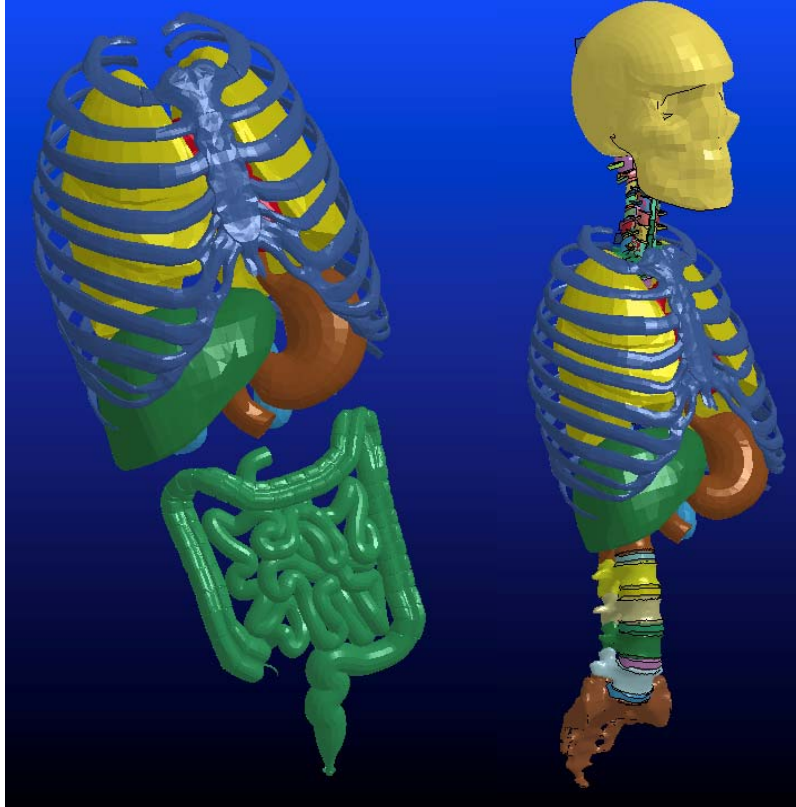

Figure 10. Anatomical Surface Models Combined with an Existing Spine and Head Model

3.0 ANALYSIS AND RESULTS

The objective of the finite element modeling and simulation was to investigate the effects of various structural components on the risk of injury to the occupant as well as other metrics. One blast model and four collision models were created.

3.1 BLAST LOADING

A blast loading model was created using the original unmodified HMMWV model. The model simulates 0.5 kg of TNT being detonated under the center of the vehicle. In order to investigate the effects of the relevant structural components, the thicknesses and modulus of elasticity of the five floor panels closest to the blast were analyzed using a mean value analysis. Each thickness and the modulus of elasticity were assumed to have a lognormal distribution with a 10% coefficient of variation (COV). The forward difference mean value analysis perturbed each value

by 10% of one standard deviation. For each perturbation the model was run out to 30 ms and the maximum floor pan displacement was outputted, Figure 11 and Figure 12.

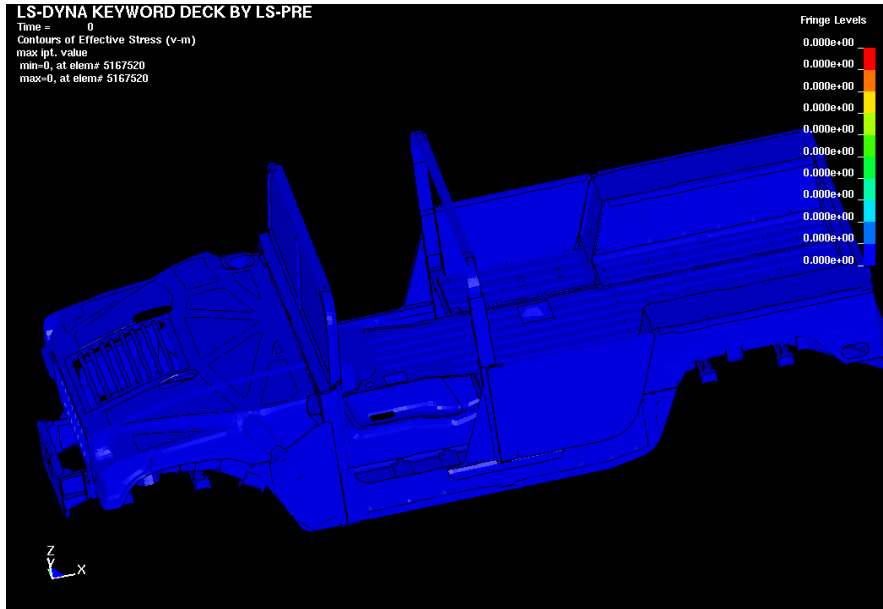

Figure 11. HMMWV model of a 0.5 kg TNT blast before detonation

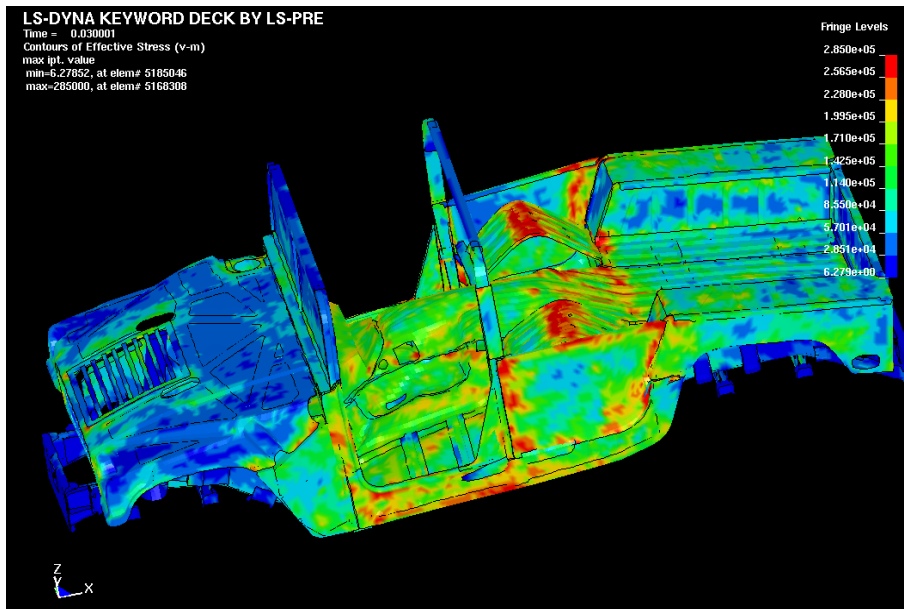

Figure 12. HMMWV model 30 ms after a 0.5 kg TNT blast with von Mises stresses shown

The cumulative distribution function (CDF) for the maximum floor displacement shown in Figure 13 gives the probability that the floor displacement will be less than a given value given the assumed variances for the model components.

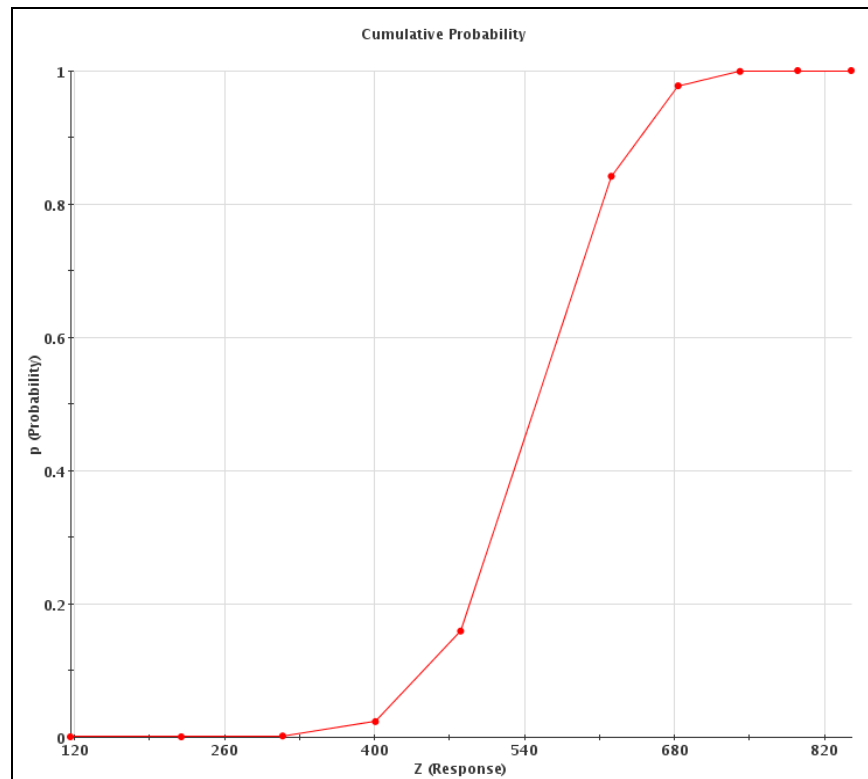

Figure 13. CDF of the maximum displacement of the HMMWV floor

The mean value analysis return importance levels for all variables that were included in the analysis. The importance levels can help determine which structural components have the greatest effect on the metric of interest. For the blast loading, the importance levels show that the thickness of the components generally has a greater effect of floor displacement than the stiffness of the material, Figure 14. As expected, the thickness of the largest floor pan had the highest level of importance in this analysis, Figure 15.

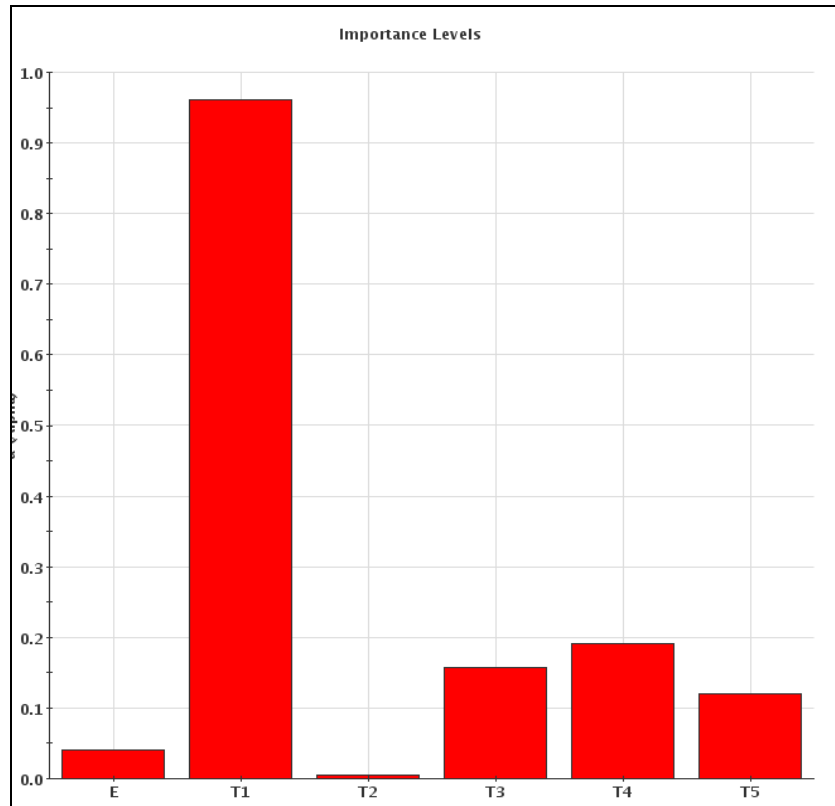

Figure 14. Importance levels for the various floor pan thicknesses and the modulus of elasticity of those components

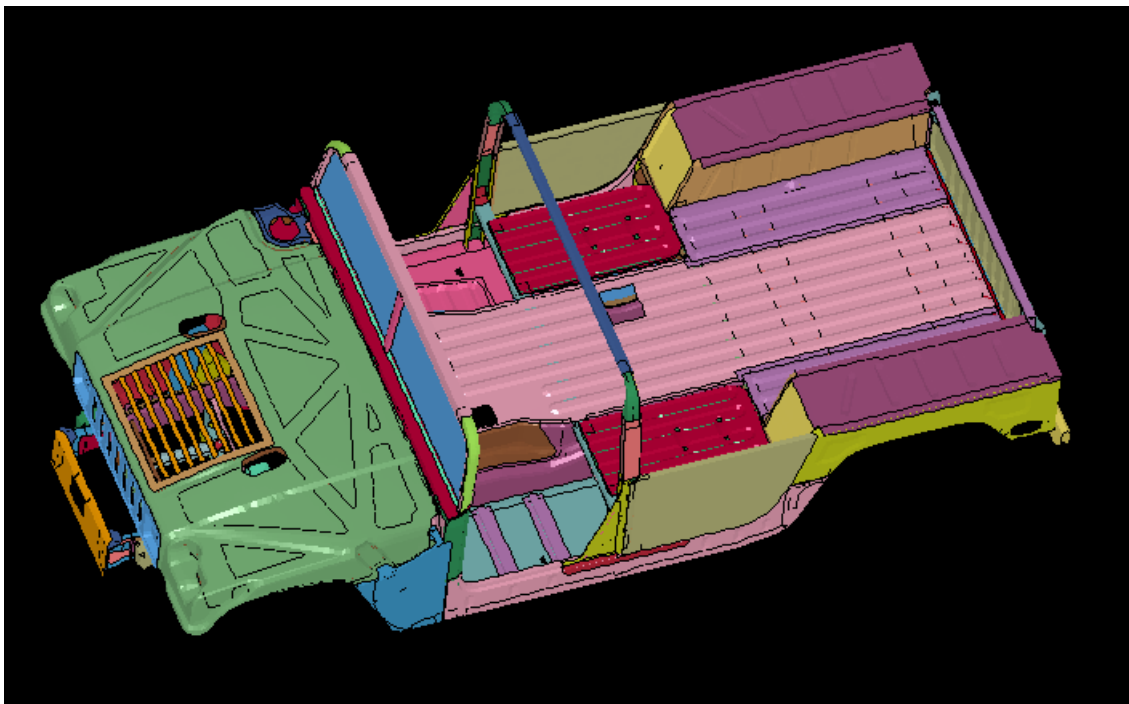

Figure 15. HMMWV FEM with the T1 component labeled

3.2 FRONTAL COLLISION

3.2.1 Hybrid III Model

Frontal collision was modeled by prescribing initial velocities of 15 and 20 mph to the HMMWV model directly in front of a rigid wall. The initial modeling of the frontal collision used the standard Hybrid III dummy model unbelted. As expected, the simulation shows the dummy model being thrown into the windshield of the vehicle model, Figure 16.

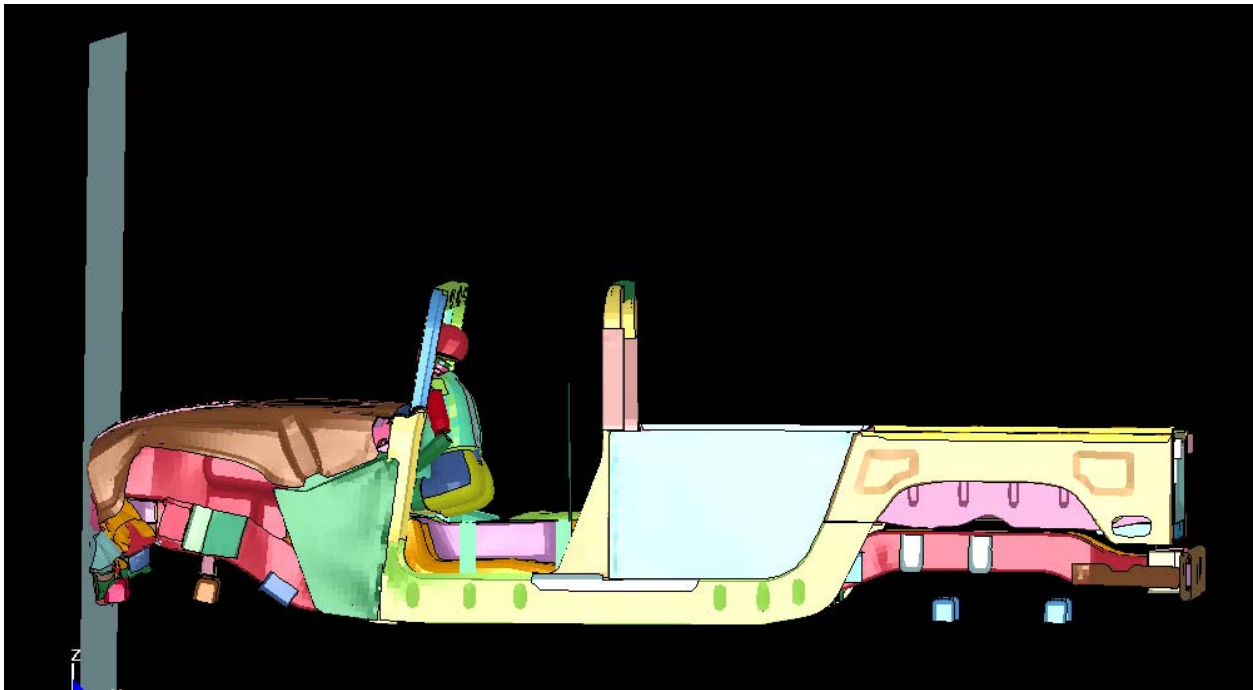

Figure 16. Frontal 15 mph crash simulation at 100 ms with an unbelted Hybrid III model

The Hybrid III dummy model was then restrained using a finite element seatbelt model. The dummy model has the ability to output head injury criteria (HIC) values which are commonly used as metric for head injury. The HIC value was used in a mean value analysis of the structural components of the HMMWV to determine which component has the greatest influence on the risk of injury during a frontal collision. Figure 17 shows the HIC time history for a 15 mph frontal collision using the belted Hybrid III dummy.

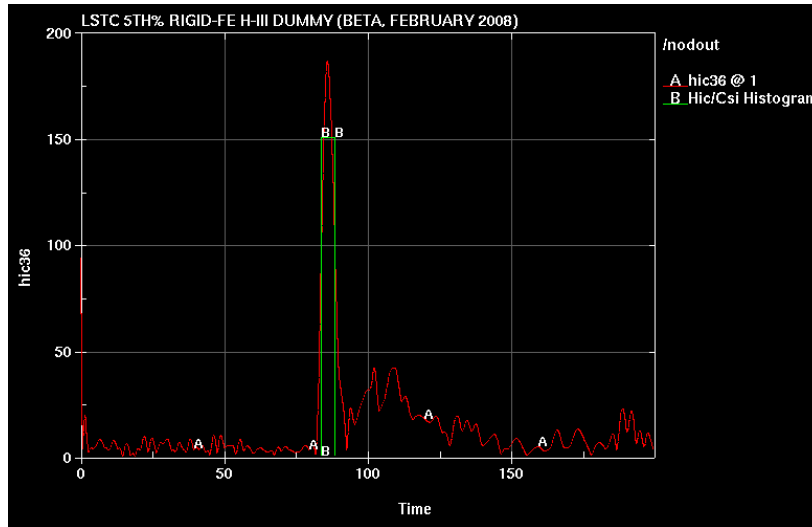

Figure 17. HIC time history for the mean value frontal collision

To assess the effect of vehicle design parameters on the occupant HIC response, the thicknesses of 32 structural components in the HMMWV were modeled as random variables with a 10% coefficient of variation (COV) and the response of the vehicle and occupant system was assessed using a Monte Carlo (MC) analysis. The MC analysis required 132 separate runs of the frontal collision simulation model. The resulting CDF, Figure 18 indicates that the occupant HIC has a COV of 15.5% given a 10% COV on material thicknesses.

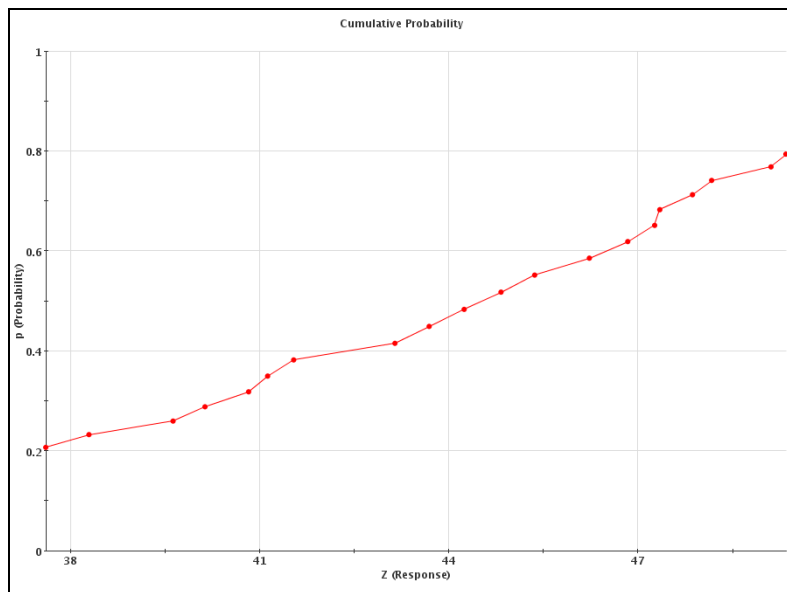

Figure 18. The cumulative distribution function for HIC values in a 20 mph frontal collision

3.2.2 High Fidelity Spine and Head Model

The high fidelity head and spine model was used in the frontal collision model to determine the risk of injury to the soft tissues of the neck. Unlike the standard Hybrid III model neck, strains and stresses for individual components of the neck can be outputted using the high fidelity spine model and used to determine the probability of exceeding published tissue injury tolerances that could result in injury to the occupant. Figure 19 shows the high fidelity head and spine model during a 15 mph frontal collision.



Figure 19. Frontal collision simulation using the NAVAIR high fidelity cervical spine and head model

A mean value analysis was performed where the thicknesses of seven of the front structural components of the HMMWV model were included as random variables, Figure 20. The thicknesses were given a lognormal distribution and a 10% COV. To test this methodology, the strain in the intra-spineous ligament was used as an injury metric. Figure 21 shows the CDF for the strain in the C5-C6 intra-spineous ligament. The CDF can be used to determine the probability of exceeding a given level of strain and therefore, the probability of injury to the occupant.

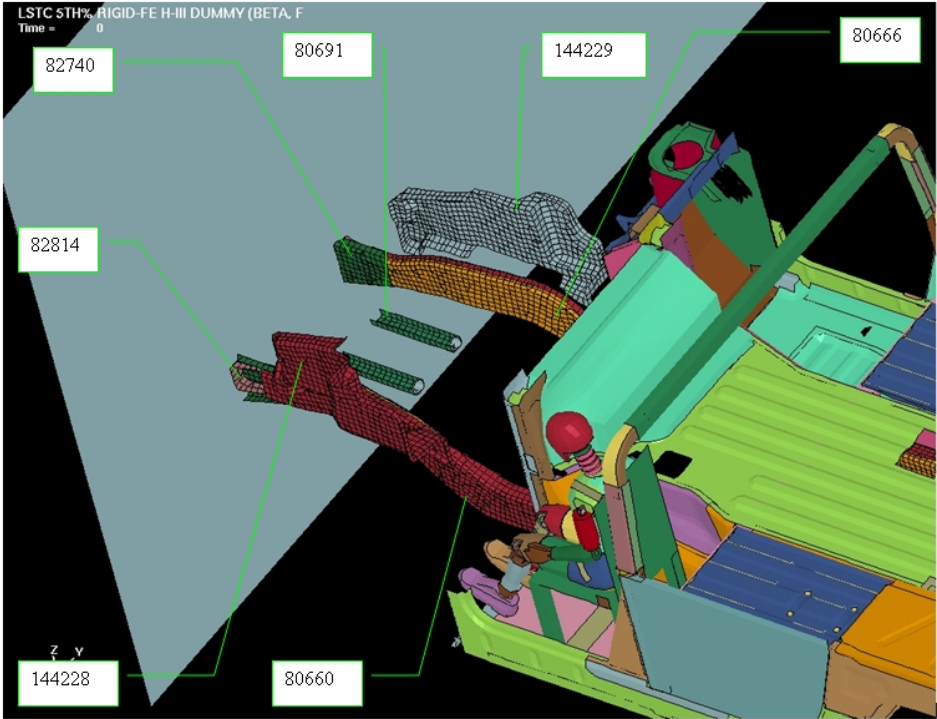

Figure 20. The seven structural components used in the mean value analysis

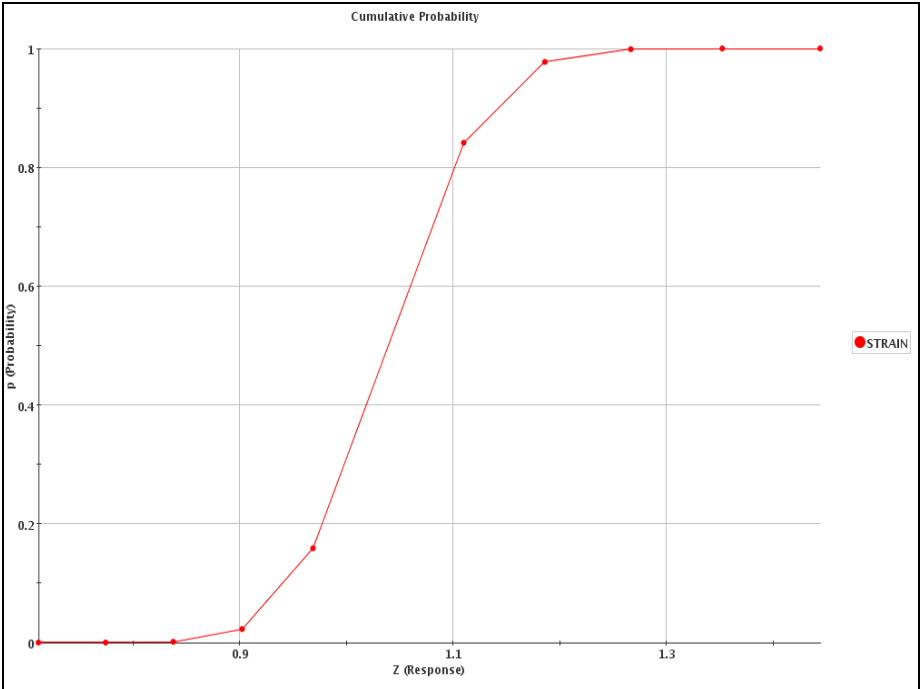

Figure 21. CDF for the strain in the C5-C6 intra-spinous ligament during a 15 mph frontal collision

3.3 REAR COLLISION

Rear collision was modeled by prescribing a negative initial velocity to the HMMWV model with a rigid wall directly behind the model. The vehicle impacts the wall causing the neck of the occupant to hyper extend and creating the possibility of injury, Figure 22.

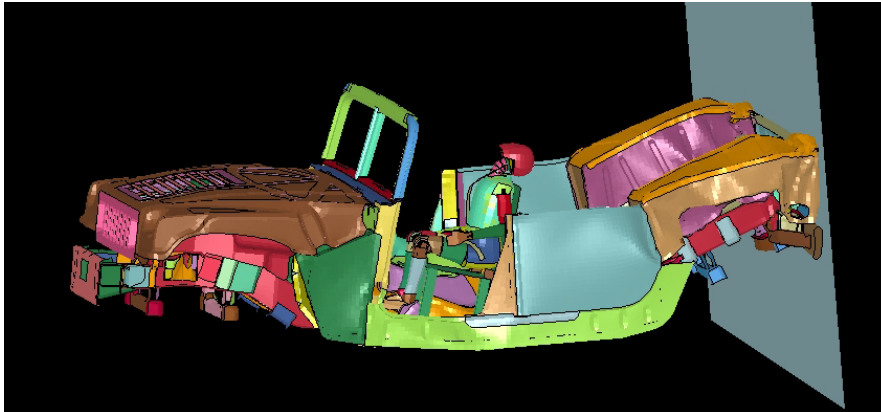

Figure 22. A 30 mph rear impact simulation

For the rear impact simulations, two different response metrics were examined. As before the HIC value was used to determine the risk of injury. In addition, door closure distance was used to determine the risk of an occupant being unable to open the door after an accident. Door closure was defined as the distance between front and rear of the door frame, Figure 23.

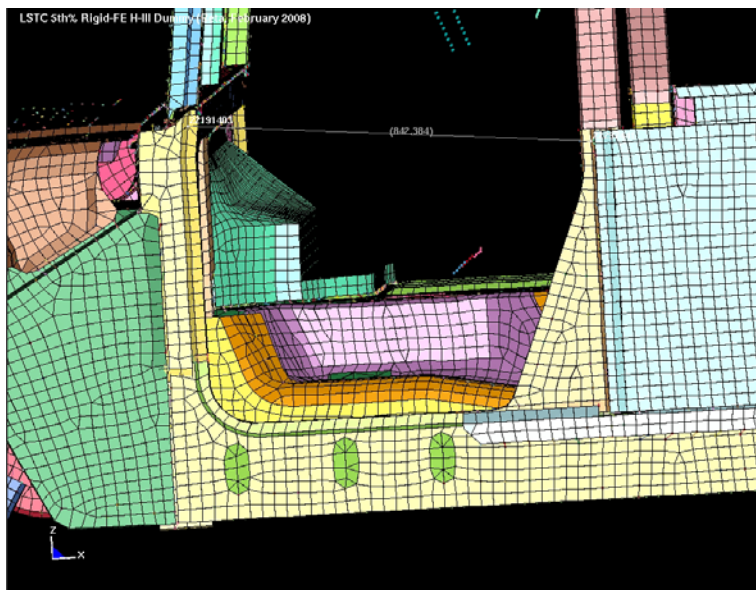

Figure 23. Door closure distance

The thicknesses of 32 structural components in the HMMWV model were made variables in a Monte Carlo analysis in order to determine the variance of the HIC and door closure distance responses resulting from a 10% COV in the vehicle material thicknesses. The MC analysis required 132 separate runs of the rear collision model. Figure 25 shows the CDF for the HIC values in a 30 mph rear impact. The generated importance levels determined that the inner frame rail of the HMMWV had the greatest impact on the HIC values, Figure 25 and Figure 26 shows the CDF for the door closure distance values in a 30 mph rear impact. The generated importance levels determined that the outer frame rail of the HMMWV had the greatest impact on the door closure distance values, Figure 27.

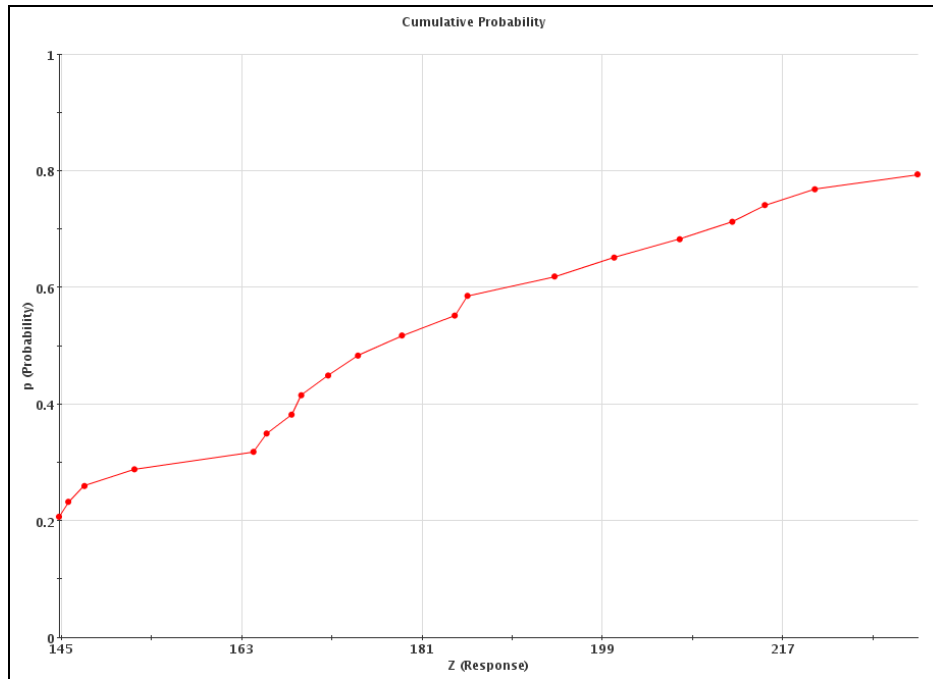

Figure 24. CDF for the HIC values in a 30 mph rear impact

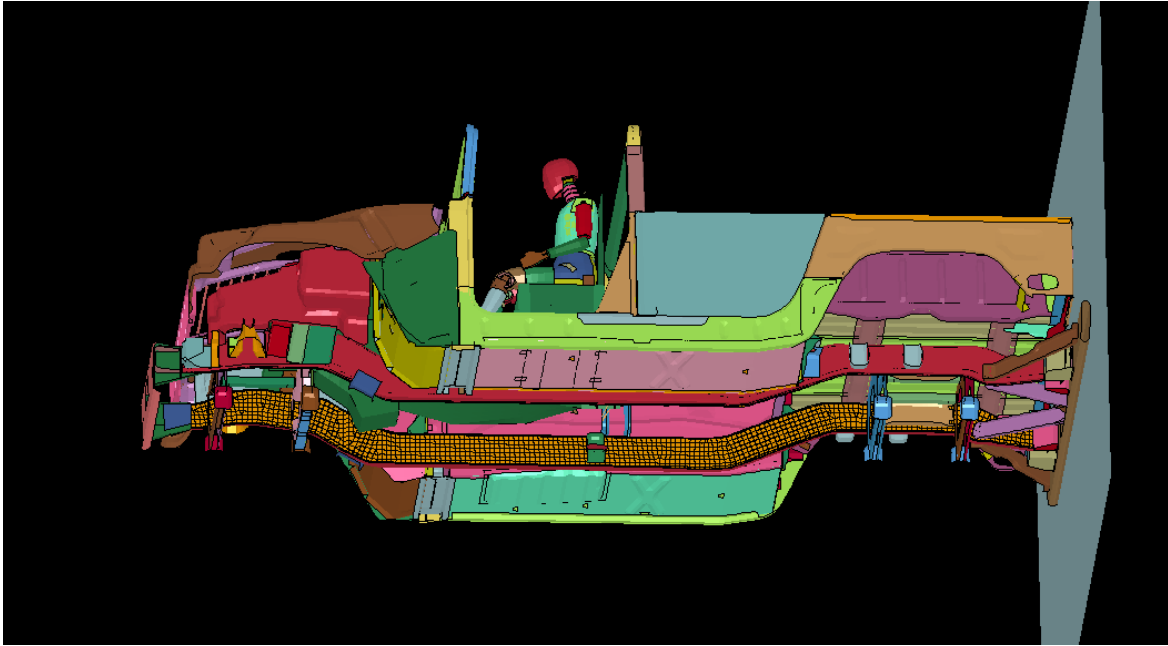

Figure 25. Frame rail part 40611 was shown to have the greatest effect to HIC values in a rear impact

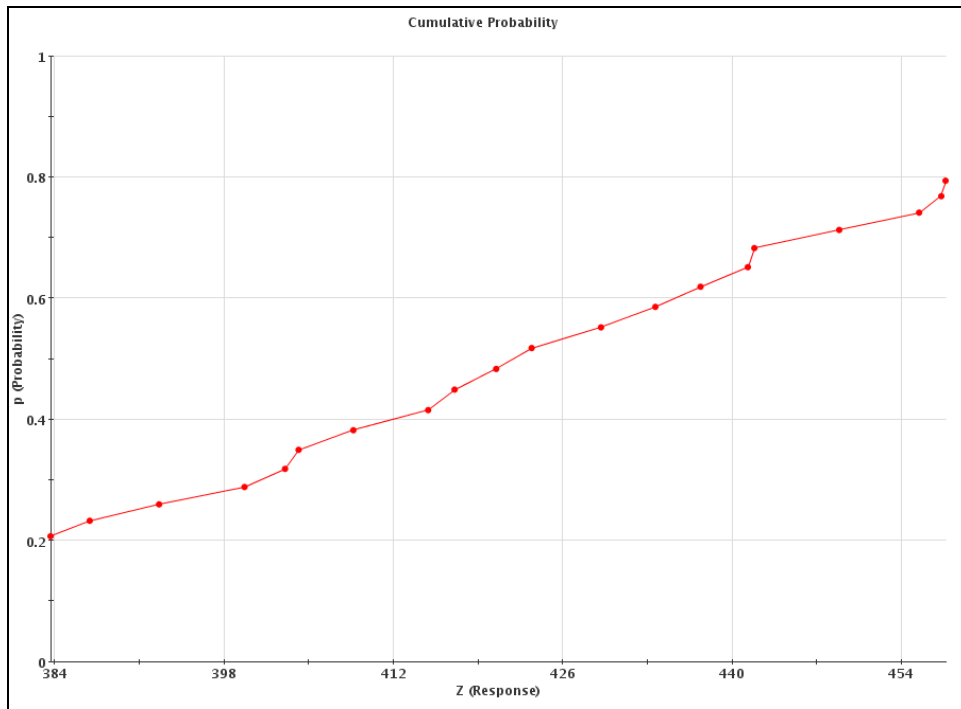

Figure 26. CDF for door closure distance in a 30 mph rear impact

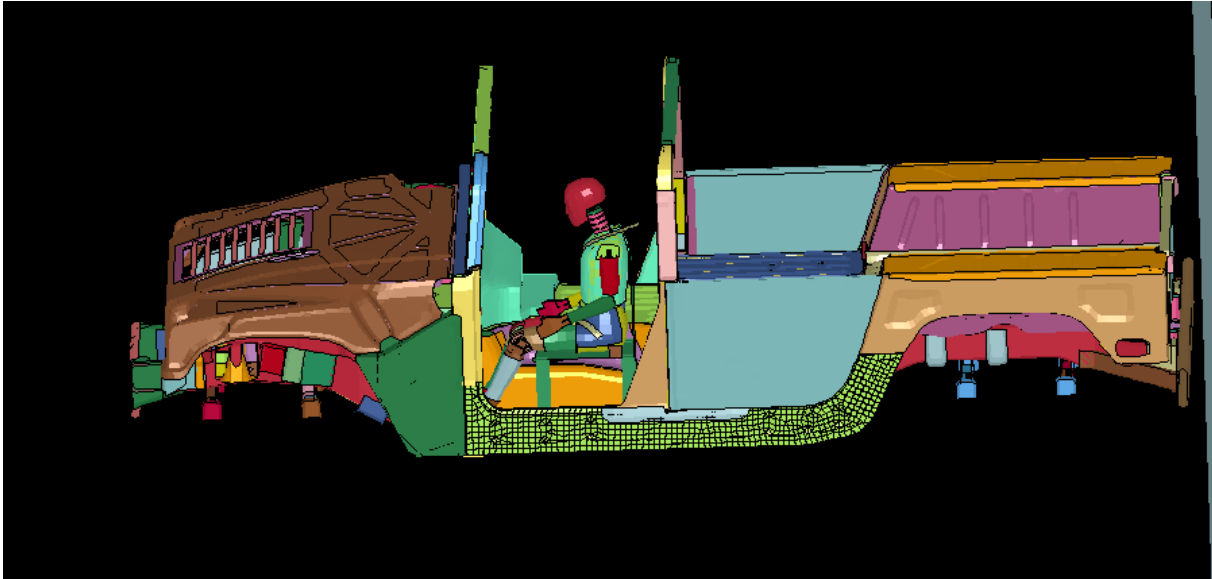

Figure 27. Part 140531 was shown to have the greatest effect on door closure distance

3.3.1 Deterministic Design Optimization of Vehicle Frame Rails

The goal of this analysis was to determine the frame rail thickness that minimizes the HIC resulting from a front impact. Design optimization is computationally challenging because it typically requires a large number of model analyses, meaning it can take days or weeks to complete. This is especially true of this problem where each analysis of the front impact model can take greater than seven hours on available hardware. To reduce this cost, we investigated the potential of solving this problem with the Efficient Global Optimization (EGO) method [3].

EGO builds a surrogate model (specifically, a Gaussian process model) of the objective function using a small number of randomly drawn samples over the input variable space. It then seeks additional training data by iteratively sampling only the regions where there is a reasonable expectation that the optimal solution might be found. By focusing on these areas, the EGO is able to locate the optimal solution with a relatively small number of objective function evaluations.

In this analysis, we seek the frame rail thickness over the bounds 1.5mm to 6mm that produces the minimum HIC value for an occupant during a front impact on the vehicle. In the first step of

solving this with EGO, three frame rail thicknesses are randomly chosen within the bounds and the front impact model is run at each thickness to determine the resulting HIC. In subsequent iterations, EGO requires only three more additional evaluations (only six total) to locate the optimal solution. For comparison, if a local, gradient-based optimizer were used in place of EGO it; 1) would likely have required additional evaluations of the model, and 2) due to the nonlinear relationship between frame rail thickness and HIC, it may not have been able to locate the global optimum (it may have converged to a local optimum instead).

The solution found by EGO is in itself somewhat uninteresting. As is intuitively expected, the minimum HIC occurs at the minimum frame rail thickness. This allows the front of the vehicle to crush, reducing the amount of energy imparted to the occupant. However, this analysis demonstrates the capabilities and benefits of applying this solver to this computationally expensive problem. Additionally, to enable solving this problem with EGO the LS-DYNA model of the front impact had to be linked with an implementation of the algorithm. The model was linked with CENTAUR (Collection of Engineering Tools for Analyzing Uncertainty and Reliability), which is a computational library developed at SwRI. This linkage enables not just EGO, but will allow us to explore the model through a variety of probabilistic analysis methods.

Probability of Head Injury due to Vehicle Impact

This problem involves calculating the probability that a person operating a High Mobility Multipurpose Wheeled Vehicle (HMMWV) would sustain a head injury due to a rear impact on the vehicle while traveling at 20 mph. The response function involves analyzing a large finite element model with LS-DYNA whose run-times can exceed seven hours, making efficiency a critical consideration. For this reason, the Efficient Global Reliability Analysis (EGRA) [4] method will be used for the analysis. Figure 28 shows an example of this model when experiencing a rear impact. Note the deflection of the driver's head in this simulation. This "snapping back" of the head can lead to severe head injuries, measured in this model by the Head Injury Criterion (HIC). In this analysis, we are concerned with the maximum HIC value sustained throughout the crash event exceeding a threshold limit of 200, i.e., $P[HIC_{max} > 200]$. Figure 29 shows an example time history of the HIC from a simulation. Note the very sharp peak clearly denoting the maximum value.

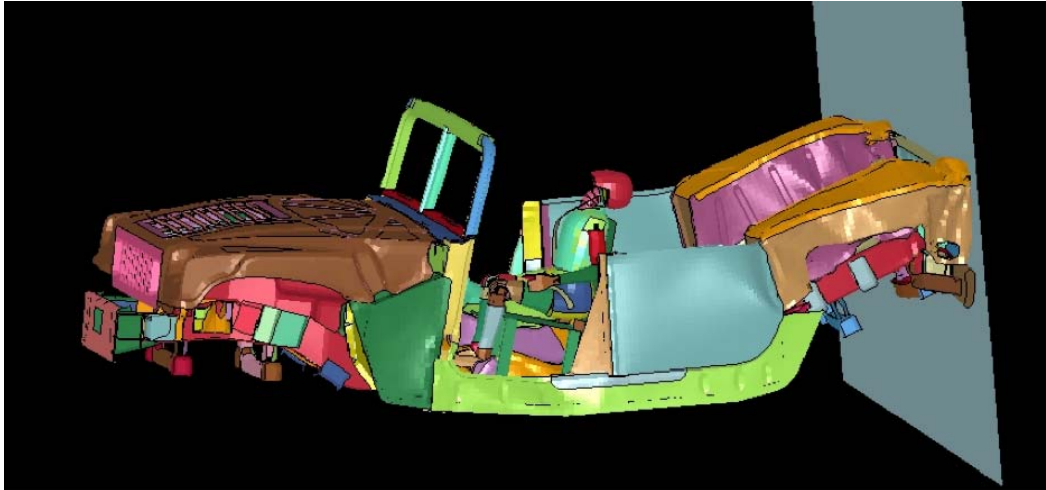

Figure 28. Simulation of rear impact of HMMWV with a rigid wall

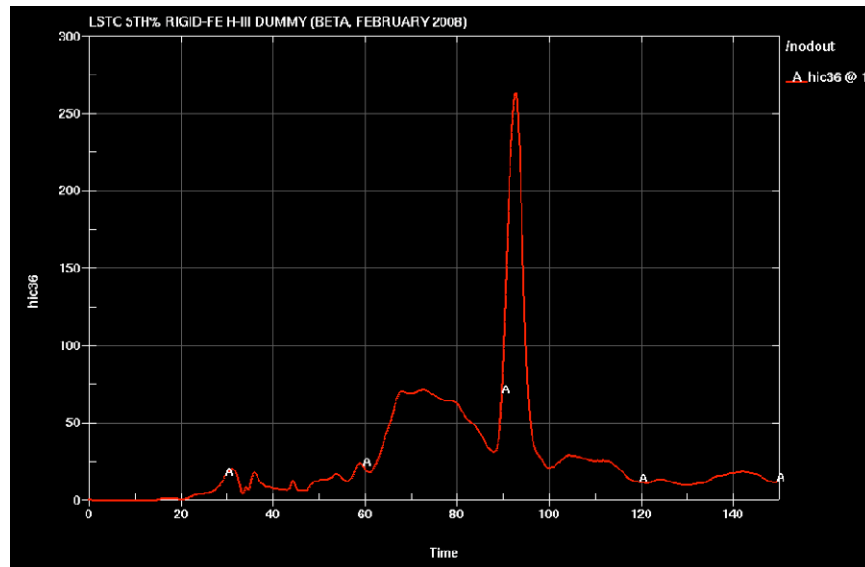

Figure 29. Time history of HIC during a crash event

The random variables being considered are the angle of vehicle impact and the thickness of the material used to construct the main frame rails that run the length of the vehicle. The angle is modeled as a Truncated Normal with a mean of 0 (indicating an impact perpendicular to the wall), a standard deviation of 30 degrees, and bounded at ± 90 degrees. The frame rail thickness is modeled as Normal with a mean of 3 mm and a standard deviation of 0.5 mm. Figure 30 shows an example of the HMMWV impacting the rigid wall at an angle.

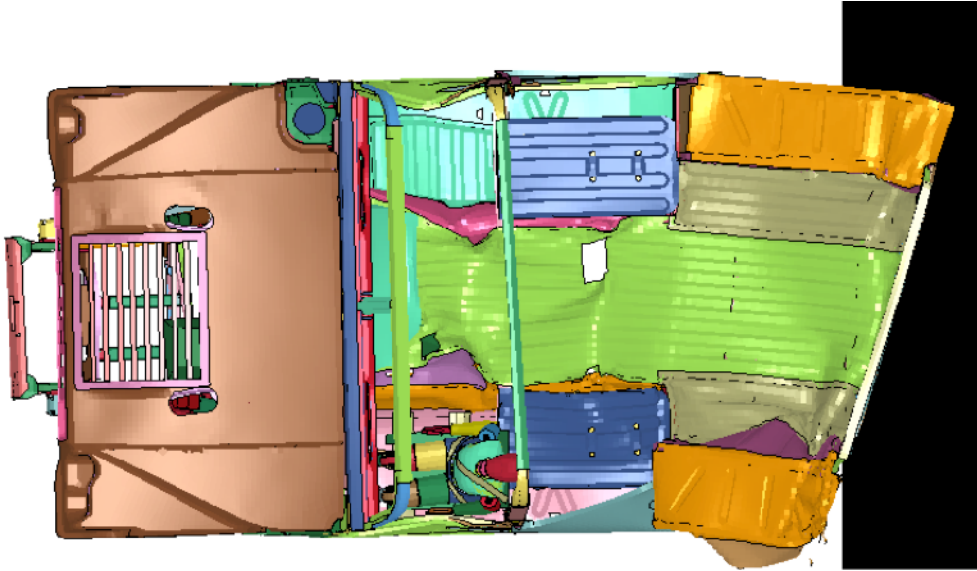

Figure 30. Top view of an angled rear impact of a HMMWV with a rigid wall

There are multiple sources of noise in this analysis. This noise causes problems for EGRA due to its reliance on Gaussian process modeling, which struggles to model this type of behavior. One source is the model discretization. Due to the size of the model, and the large expense already entailed in its analysis, it is not finely meshed throughout. Another is the dynamic modifications to the model during the analysis. As portions of the HMMWV are crushed, some elements become highly deformed, causing numerical difficulties for the analysis, and are removed from the model. An additional source of noise comes from the post-processing of the model data to extract the maximum HIC value. This requires an amount of curve-fitting and interpolation, which can introduce uncertainty. All of these are artifacts of the modeling process and not representative of the true physics of the impact, and can thus be qualified as unwanted noise in the model response.

Unfortunately, it is difficult to quantify the amount of noise these factors contribute to the response. EGRA, or more specifically, the GP model used by EGRA, is capable of “smoothing through” this noise, but it requires that standard deviation of the noise, σ_{noise} , be provided at the time the model is constructed. For this problem, providing this value is a real challenge. In this analysis, a value of 20 is used. The analysis was run until 54 training points had been added. Figure 31 shows the limit state contours for the mean and the 90% confidence bounds. It is clear

that even with this level of sampling, a considerable amount of uncertainty remains on the limit state. This is confirmed when the confidence bounds on the probability of failure are calculated and shown to be fairly wide; with this model there is 90% confidence that $0.0342 \leq p_f \leq 0.148$.

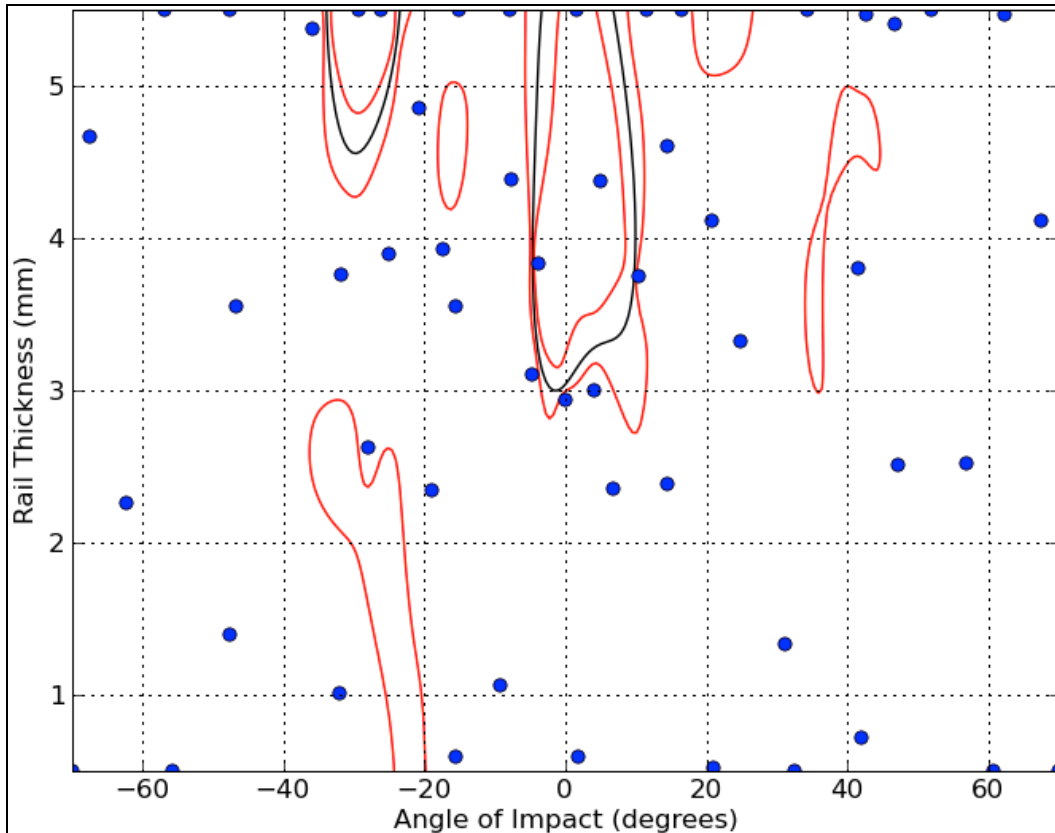

Figure 31. Contour plot of HIC = 200 contours with confidence bounds and $\sigma_{noise} = 20$

Further investigation indicates that using $\sigma_{noise} = 20$ is likely too small. Plots of the GP surface (not shown here because these three dimensional plots are difficult to convey on paper) show that it remains quite noisy; it does not “smooth out” the noise as desired. Increasing the noise level to $\sigma_{noise} = 40$ has a dramatic effect on the model. The surface (again, not shown) appears to provide the desired level of smoothing, the limit state contours, shown in Figure 32 are much better behaved, and the 90% confidence bounds have now been reduced to $0.0413 \leq p_f \leq 0.0597$.

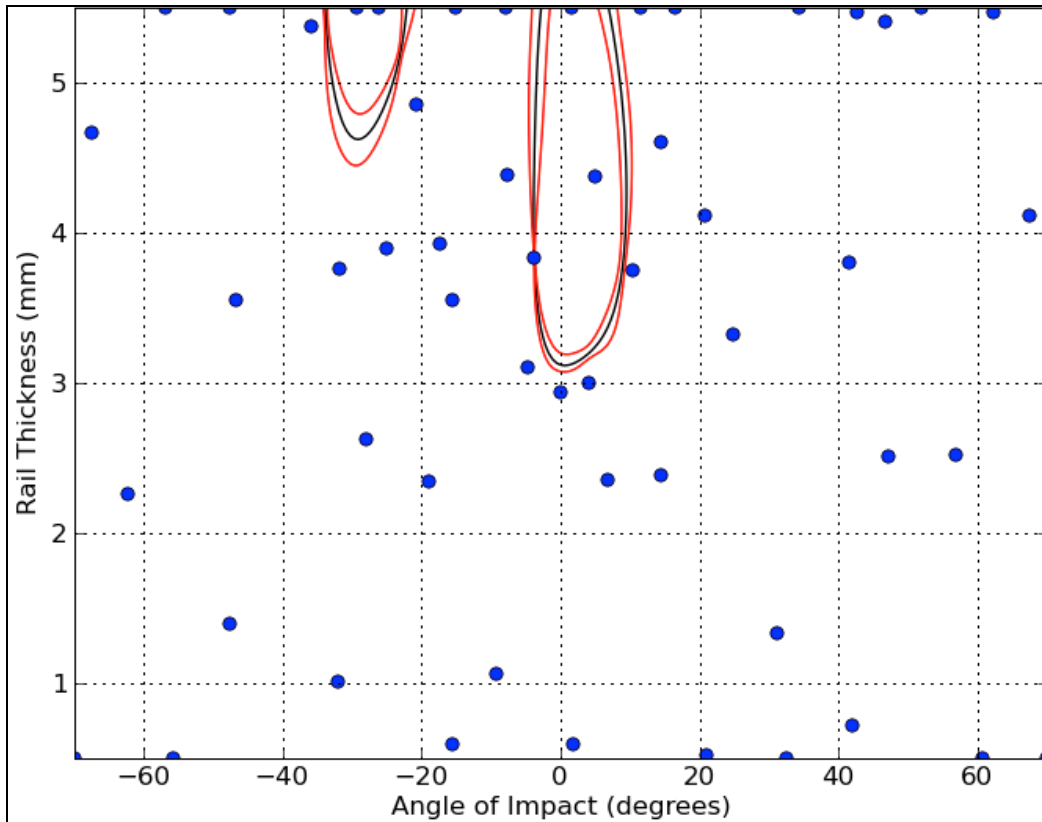

Figure 32. Contour plot of HIC = 200 contours with confidence bounds and $\sigma_{\text{noise}} = 40$

While it is beneficial to learn more about the function, it should be noted that changing the noise level after EGRA has run for several iterations is potentially quite different than running EGRA with the noise level from the beginning. The algorithm would have likely selected different training data along the way, and in this particular case, may have even allowed the method to converge before reaching this number of iterations. It is clear that properly selecting the level of noise in the response can have a significant effect on the convergence of EGRA and the results it provides. An approach for determining the appropriate noise value has not been investigated as a part of this effort and may be a candidate for future research.

3.4 SIDE COLLISION

A model was created to simulate a side impact. The side impact model simulates the vehicle striking a large cylindrical pillar at 30 mph, Figure 33. The methodologies and analysis techniques described in sections 3.2 and 3.3 could be applied to these models as well.

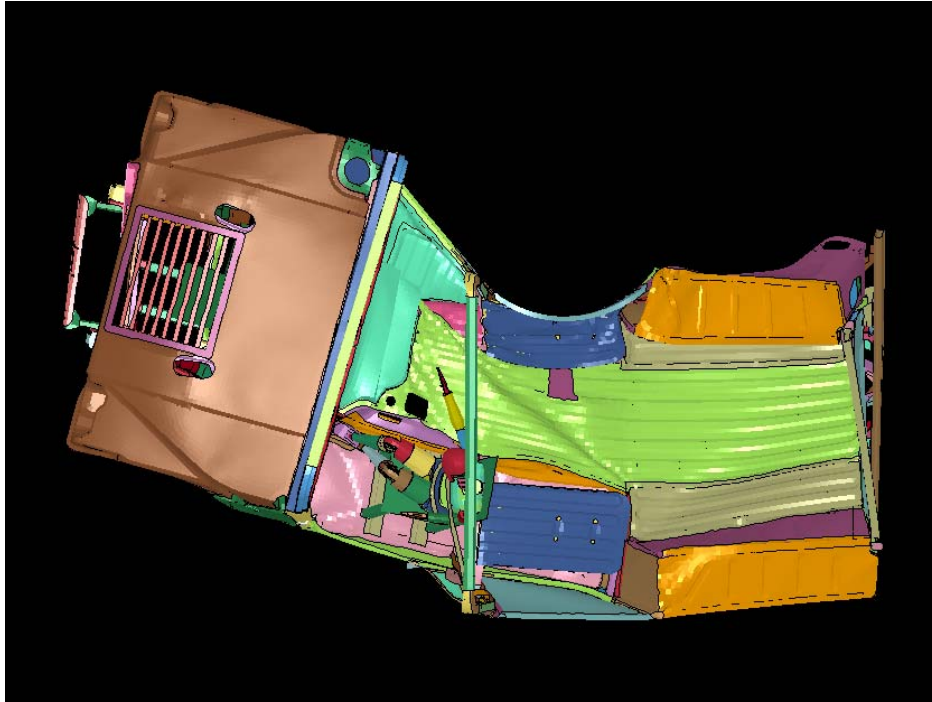

Figure 33. Side impact model

4.0 CONCLUSIONS AND DISCUSSION

This program has shown that the use of probabilistic modeling in combination with biomechanical modeling can be a powerful tool in evaluating designs and mitigating injury risk for military vehicle occupants.

When designing mitigation strategies there are often competing factors. To protect against IED, many HMMWV have steel plating welded on to the vehicle. However, the additional material results in a stiffer structure which increases risks of injury to the occupant in a collision. Using the methods developed for this program, those increased risks can be quantified so that informed

vehicle design decisions can be made that will minimize the risk of injury to vehicle occupants for multiple injurious events.

The methods and techniques used in this program are only accurate when verified and validated models are used. For this program, obtaining an accurate vehicle model was the limiting factor. The materials in the HMMWV model were a generic steel material model. While, this limitation did not affect the overall objective of developing tools and methods to determine risk, it did, however, prevent the program from determining mitigation strategies for reducing risk of injury for this specific vehicle. There is a need for detailed and accurate vehicle finite element models.

Another limitation of this program is the lack of injury data from the battle field. Injury data is needed to determine where the focus of this type of research should lie. If, for instance, the predominant injury scenario includes an unbelted occupant, then the simulations would need to be adjusted to reflect that reality. Once injury data is available, the methods and models could quickly be modified to include the addition knowledge.

In conclusion, an advanced military vehicle simulation methodology has been developed to assess the risk of injury to the warfighter vehicle occupant. Advanced probabilistic, design and reliability based optimization, and biomechanical modeling techniques were successfully synthesized to produce a methodology that is capable of quantitatively assessing specific risk of injury due to various potentially injurious vehicle loading conditions including front and rear collisions and exposure to IED blast loading. This methodology enables the quantitative assessment of proposed design alterations to existing vehicles and the quantitative assessment of completely new vehicles on warfighter injury risk. Furthermore, design changes can be systematically optimized to provide maximum vehicle performance while maintaining warfighter safety with the implementation of deterministic and reliability based design methodologies.

LIST OF REFERENCES

- [1] Thacker, B., Francis, W., Nicolella, D. *Model Validation and Uncertainty Quantification Applied to Cervical Spine Injury Assessment*. NATO AVT Symposium on Computational Uncertainty in Military Vehicle Design, 2007.
- [2] Chancey, V., Nightingale, R., Van Ee, C., Knaub, K., & Myers, B. (2003) *Improved estimation of the human neck tensile tolerance: reducing the range of reported tolerance using anthropometrically correct muscles and optimized physiologic initial conditions*. Stapp Car Crash Journal, v. 47.
- [3] Jones, D., Schonlau, M., and Welch, W., *Efficient Global Optimization of Expensive Black-Box Functions*, *INFORMS Journal on Computing*, Volume 12, pp. 272-283, 1998.
- [4] Bichon, B. J., Eldred, M. S., Swiler, L. P., Mahadevan, S., and McFarland, J. M., *Efficient Global Reliability Analysis for Nonlinear Implicit Performance Functions*, *AIAA Journal*, Volume 46, No. 10, pp. 2459-2468, 2008.