

AD _____

Award Number: W81XWH-07-1-0FG

TITLE: *[Illegible text]*

PRINCIPAL INVESTIGATOR: *[Illegible text]*

CONTRACTING ORGANIZATION: *[Illegible text]*

REPORT DATE: *[Illegible text]*

TYPE OF REPORT: *[Illegible text]*

PREPARED FOR: U.S. Army Medical Research and Materiel Command
Fort Detrick, Maryland 21702-5012

DISTRIBUTION STATEMENT: Approved for public release; distribution unlimited

The views, opinions and/or findings contained in this report are those of the author(s) and should not be construed as an official Department of the Army position, policy or decision unless so designated by other documentation.

REPORT DOCUMENTATION PAGE

Form Approved
OMB No. 0704-0188

Public reporting burden for this collection of information is estimated to average 1 hour per response, including the time for reviewing instructions, searching existing data sources, gathering and maintaining the data needed, and completing and reviewing this collection of information. Send comments regarding this burden estimate or any other aspect of this collection of information, including suggestions for reducing this burden to Department of Defense, Washington Headquarters Services, Directorate for Information Operations and Reports (0704-0188), 1215 Jefferson Davis Highway, Suite 1204, Arlington, VA 22202-4302. Respondents should be aware that notwithstanding any other provision of law, no person shall be subject to any penalty for failing to comply with a collection of information if it does not display a currently valid OMB control number. **PLEASE DO NOT RETURN YOUR FORM TO THE ABOVE ADDRESS.**

1. REPORT DATE (DD-MM-YYYY) 01-04-2011		2. REPORT TYPE Final		3. DATES COVERED (From - To) 26 FEB 2007 - 31 MAR 2011	
4. TITLE AND SUBTITLE Feasibility of Dual Optical/Ultrasound Imaging and Contrast Media for the Detection and Characterization of Prostate Cancer				5a. CONTRACT NUMBER	
				5b. GRANT NUMBER W81XWH-07-1-0125	
				5c. PROGRAM ELEMENT NUMBER	
6. AUTHOR(S) Dr. David Hall E-Mail: djhall@ucsd.edu				5d. PROJECT NUMBER	
				5e. TASK NUMBER	
				5f. WORK UNIT NUMBER	
7. PERFORMING ORGANIZATION NAME(S) AND ADDRESS(ES) The University of California La Jolla, CA 92093				8. PERFORMING ORGANIZATION REPORT NUMBER	
9. SPONSORING / MONITORING AGENCY NAME(S) AND ADDRESS(ES) U.S. Army Medical Research and Materiel Command Fort Detrick, Maryland 21702-5012				10. SPONSOR/MONITOR'S ACRONYM(S)	
				11. SPONSOR/MONITOR'S REPORT NUMBER(S)	
12. DISTRIBUTION / AVAILABILITY STATEMENT Approved for Public Release; Distribution Unlimited					
13. SUPPLEMENTARY NOTES					
14. ABSTRACT This research project focuses on prostate cancer, a devastating socioeconomic disease, whose detection is plagued with inadequate sensitivity and specificity. Hypoxia is the hallmark of malignancy because aggressive cancers outgrow their blood supply. We ultimately aim to build an instrument that combines Optics and UltraSound (OPUS) to quantify hypoxia via optical imaging but with the improved spatial resolution of US imaging. Specifically, the acoustooptic effect will be used to only modulate light (at the ultrasound frequency) which propagates through a small ultrasound focal zone. This DOD Idea Development Award is concerned with the development of a novel acousto-optic detection method and using microbubble-based contrast agents to significantly increase the light modulation and, moreover, the use of fluorescent microbubbles to provide additional enhancement. During the first year of the research project we demonstrated the detection of ultrasound-modulated incoherent photons followed by novel quadrature detection of ultrasound-modulated photons and fluorescence photons with a gain-modulated image intensified CCD camera approach. During the second year of the research project we demonstrated significant signal enhancement with ultrasound microbubbles and generation of higher harmonic modulation. We also demonstrated acoustooptic detection with a novel SPAD detector. During the third year of this research project we developed a novel acousto-optic light scattering system to robustly characterize ultrasound-induced oscillation of individual microbubbles and also observed microbubble collapse and implosion at higher ultrasound pressures. In the fourth and final year of this project we manufactured quenchable fluorescent microbubbles and modified the system to detect their ultrasound-modulated fluorescence. As such, this project was an overall success with all tasks completed. Ultimately, in vivo acousto-optic imaging has the potential to diagnose prostate cancer at ultrasound spatial resolution based on optical contrast of endogenous hypoxia with microbubbles or quenchable fluorescent microbubbles for additional enhancement.					
15. SUBJECT TERMS prostate, cancer, imaging, acousto-optic, optical, ultrasound, fluorescence, microbubbles					
16. SECURITY CLASSIFICATION OF:			17. LIMITATION OF ABSTRACT	18. NUMBER OF PAGES	19a. NAME OF RESPONSIBLE PERSON
a. REPORT U	b. ABSTRACT U	c. THIS PAGE U			USAMRMC
			UU	29	19b. TELEPHONE NUMBER (include area code)

Table of Contents

	<u>Page</u>
Introduction.....	4
Body.....	4
Key Research Accomplishments.....	15
Reportable Outcomes.....	16
Conclusion.....	17
References.....	18
Appendices.....	18

INTRODUCTION

This research project focuses on prostate cancer, a devastating socioeconomic disease, whose detection is plagued with inadequate sensitivity and specificity. Hypoxia is the hallmark of malignancy because aggressive cancers outgrow their blood supply. Optical imaging is emerging as a physiologic tool capable of quantifying hypoxia but only at centimeter spatial resolution which is unacceptable for prostate cancer imaging. We ultimately aim to build an instrument that combines Optics and UltraSound (OPUS) to quantify hypoxia via optical imaging but with the improved spatial resolution of US imaging. Specifically, the acousto-optic effect will be used to only modulate light (at the ultrasound frequency) which propagates through a small ultrasound focal zone. Optical images generated from only ultrasound-modulated light will thus have the improved spatial resolution of the ultrasound focal zone. The main difficulty is the detection and discrimination of ultrasound-modulated light from the overwhelming presence of non-modulated light not passing through the ultrasound focal zone. This DOD Idea Development Award is concerned with the development of a novel detection idea based on quadrature measurements with a gain-modulated image intensified CCD camera. Furthermore, we proposed the novel idea of using microbubble-based contrast agents to significantly increase the light modulation and, moreover, the use of fluorescent microbubbles to provide additional enhancement.

BODY

The Statement of Work outlined four main tasks for this project. The following describes the research conducted to date for each task:

First Year

Task 1. Prove that modulating optical signal amplification with the US frequency to preferentially amplify the modulated photons results in improved SNR.

For acousto-optic imaging, the size and location of the US-focal zone provides the image spatial resolution and the optical detector is simply used to collect as many modulated photons as possible to improve SNR. For the detection of ultrasound-modulated coherent light, simple use of a collection lens to focus many speckles to a single detector results in phase-cancellation which ultimately eliminates the modulation signal rather than increasing it. Hence, some researchers[1] have used a CCD camera for parallel detection where each pixel acts as an independent detector to detect a larger number of speckles. However, since the frame-rates of CCD cameras are not capable of monitoring the speckle modulation via ultrasound (MHz) in real-time, some researchers[2] examine the speckle contrast of a single CCD frame which is inversely proportional to the magnitude of the acousto-optic effect.

As hypothesized in task 1, we expected the use of an image intensified CCD camera gain-modulated at the ultrasound frequency would lead to a greater change in the speckle contrast correlated with increasing the detector gain. These initial experiments employed a laser diode (5 mW at 650 nm, coherence length of ~5 M) to illuminate a water tank (65 mm wide) to which we added varying amounts of intralipid as an optical scatterer. Light was detected with a gain-modulated image intensifier (Picostar HRI, LaVision, Germany) with a highly sensitive electron-multiplying CCD camera (Andor, CA) to detect the output of the image intensifier and store it on the acquisition computer. Modulation of the image intensifier gain was achieved with a function generator (Stanford Research Systems, DS345) outputting a sine wave at the ultrasound frequency and phase-locked ($\Delta\Phi = 0$) to a second identical function generator input to an RF Amplifier (ENI, 240L) to drive a single-element ultrasound transducer (Panametrics, V303) with a 1 MHz sine wave (50 Vpp) with 20 pulses (20 μ s pulse-length) every millisecond (2% duty cycle). The US transducer was submerged in the water tank such that its focal zone (mechanically focused to 1.5 inches) intercepted the line-of-sight between the laser diode and the image intensifier in transmission mode. Since speckles are typically around 10 μ m (similar size to 8 μ M CCD pixel) we used an extension tube (PN-11, Nikon) and 50 mm f/1.4 Lens (Nikon) to achieve 1:1 imaging (i.e. 8 μ m spatial resolution) over an 8 x 8 mm (1000 by 1000 pixels) field of view. The experimental configuration is shown in Figure 1.

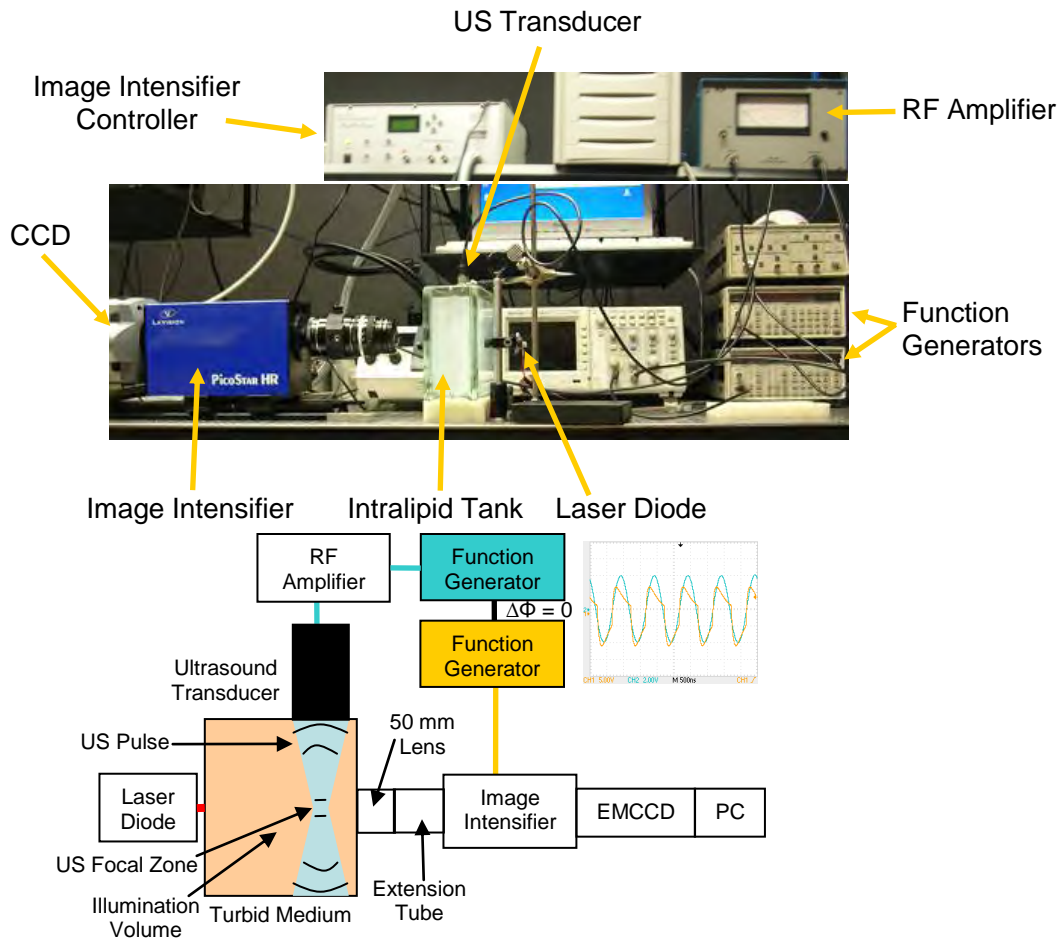
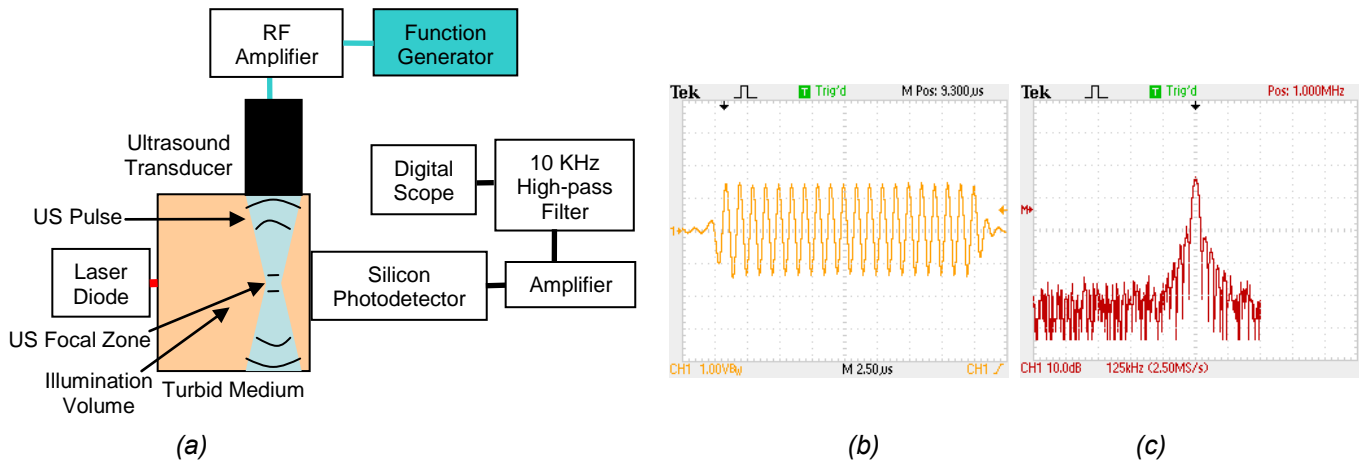

Figure 1 a) Experimental configuration for acousto-optic detection with gain-modulated image intensifier
 1b) Schematic representation

A baseline measurement was first performed with no gain modulation, i.e. a steady-state gain, with and without the ultrasound being applied to measure the change in speckle contrast. The image intensifier was set to 300 V, the CCD integration time to 400 ms, and 100 sequential images were acquired. The speckle contrast is defined as the standard deviation of the image intensity (σ) divided by the mean intensity ($\langle I \rangle$). Without ultrasound we measured an average speckle contrast of 0.03557 and with ultrasound an average speckle contrast of 0.03548 demonstrating the decrease as expected. However, upon further analysis we found the standard deviation in the speckle contrast across the 100 images was 0.0002 and so this decrease was within the measurement error. We explored a variety of image intensifier voltages and CCD integration times but were unable to detect any statistically meaningful difference in the speckle contrast with and without ultrasound being applied. This result was somewhat surprising, but undaunted we proceeded to try and detect a change in speckle contrast when applying a gain-modulation to the image intensifier. The image intensifier is comprised of a microchannel plate (MCP) held at a high amplification voltage and a photocathode whose response is modulated by the function generator. Unfortunately, even with full modulation of the photocathode we were still unable to detect any difference in the speckle contrast with and without ultrasound being applied. This result was unexpected and somewhat concerning, causing us to recheck that the equipment was indeed operating correctly.

At this stage of the project we had been unable to detect the elusive ultrasound-modulated photons and decided to simplify the set-up to a more basic experimental configuration. The gain-modulated image intensified CCD was replaced with an amplified (20 dB) silicon photodetector (PDA36A, ThorLabs). Although this is essentially only one pixel compared to the CCD camera, it has sufficient bandwidth (MHz range) to follow the signal in real time which the CCD cannot. Unlike the previous experiment which resolved individual speckles, we simply detected all the transmitted light over $\sim 1 \text{ cm}^2$ area. The output of the silicon photodetector was further amplified and passed through a high pass-filter (Stanford Research Systems, SR560), $>10 \text{ KHz}$, to remove DC and low frequency noise before being recorded on a digital scope (Tektronix, TDS 2012B). Under

this experimental configuration, Figure 2a, we were finally able to detect the ultrasound-modulated optical signal which was recorded on the scope (Fig. 2b). A Fourier transform of this signal (Fig. 2c) clearly shows a peak at 1 MHz (the ultrasound frequency) where the amplitude is proportional to the magnitude of the acousto-optic effect. As a control, the measurement was repeated without the ultrasound being applied for which there was no modulation detected in the optical signal.



(a) Experimental set-up for detection of ultrasound-modulated coherent light with a silicon photodetector
 (b) Optical modulation detected and recorded on the digital scope.
 (c) Fourier transform demonstrating optical modulation is at the US modulation frequency.

This experimental result is critical and demonstrates that we can detect ultrasound-modulated photons when all the individual speckles are spatially integrated on the detector. As discussed above, the spatial integration of random speckles leads to phase-cancellation which should destroy any modulation. This led us to speculate that the modulation observed here is not due to modulated speckles, caused by modulating the interference pattern of coherent photons, but rather, due to modulation of the local optical attenuation which essentially modulates the intensity of the photons in phase. The optical attenuation can be modulated via changes in the refractive index, optical absorption and scattering, and/or density of scatters by the ultrasound wave. Furthermore, modulation of the optical attenuation should modulate photon intensity regardless of whether the photons are coherent or incoherent.

To date, most acousto-optic researchers[1] have relied upon the use of coherent photons with the necessity for photon coherence from optical source to ultrasound-focal-zone to optical detector imposing a requirement on the laser to have a long coherence length (at least as long as the optical pathlength). For highly scattering media, the optical pathlength can easily reach six times the geometrical distance[3] restricting the choice of available lasers. The ability to intensity-modulate incoherent photons with ultrasound removes this constraint permitting a wider range of optical sources to be considered. Moreover, since the fluorescence process is inherently incoherent, it allows the potential for ultrasound-modulation of fluorescence photons. We therefore modified our experimental set-up, Figure 3a, to demonstrate the detection of ultrasound-modulated incoherent photons. We simply replaced our coherent laser diode (Figure 2a) with an incoherent light source (100 W Halogen Lamp, Schott KL1500). As expected, Figure 3b show the detected and recorded modulation of the optical signal which exhibits modulation at the ultrasound frequency of 1 MHz. Note, the envelope is caused by a lower frequency modulation from the lamp that was not blocked by our frequency filter.

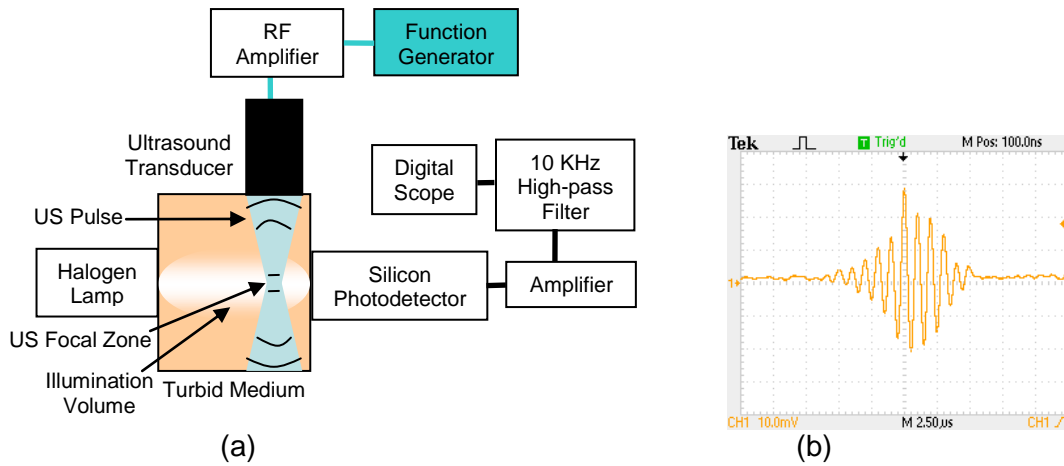

Figure 3a) Experimental set-up for AO measurements of ultrasound-modulated incoherent light.
 3b) Optical modulation at 1 MHz detected and recorded on the digital scope.

Although we did not detect the expected change in speckle contrast and could therefore not demonstrate an improvement in SNR, this research led to the novel ultrasound-modulation of incoherent photons. Moreover, the idea that all the photons are modulated in phase by modulation of the optical attenuation explains why we did not observe any change in speckle contrast when applying ultrasound. The decrease in speckle contrast from coherent photons by the addition of ultrasound observed by others[2] relies on the principle that the standard deviation of the intensity decreases while the average intensity remains unaffected as all the random phases of the speckles cancel out. However, a modulation of the optical attenuation by ultrasound causes an in phase intensity modulation which simply scales the standard deviation and average intensity such that the speckle contrast remains unchanged as we observed.

Task 2. Prove that the use of a Picostar camera system and a quadrature technique results in faster data acquisition without loss of SNR.

Particularly novel to this project is the proposed quadrature detection of ultrasound-modulated photons with a gain-modulated image intensifier to detect ultrasound-modulated photons[4]. Here, a continuous wave laser source is employed and the gain of the optical detector is modulated at the same frequency as the ultrasound. The CCD image is then acquired at four different phase shifts between the optical detector modulation and ultrasound modulation. The idea is inspired by the way wide-field fluorescence lifetime imaging microscopy (FLIM) is performed[5]. For this application, Fig. 4, a modulated (~ hundreds of MHz) light-emitting diode (LED) source is employed to excite a fluorophore resulting in a modulated fluorescence signal where the fluorophore lifetime induces a phase shift. Hence, the measurement of phase shift at each pixel enables a fluorescence lifetime image to be generated.

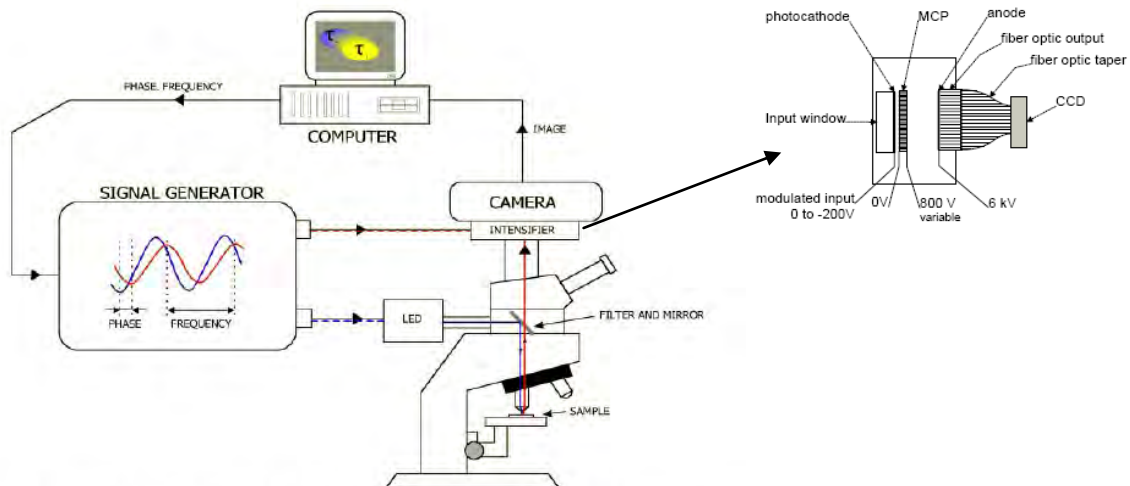

Figure 4. FLIM system setup: Wide-field fluorescence microscope and LIFA attachment for FLIM

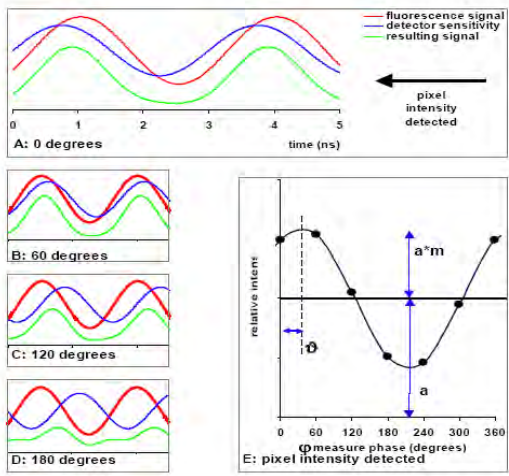

Figure 5. Cross-Correlation Principle

The measurement of phase shift is achieved by modulating the photocathode of the image intensifier at the same frequency as the LED. The resultant signal detected on the CCD pixel is thus a product of the phase-shifted fluorescence signal and the optical detector sensitivity. However, a time-averaged signal is recorded since a CCD does not have sufficient frame-rate to follow this signal. Nevertheless, by acquiring this signal at four different phases, Fig 5, one is able to measure the cross correlation of the fluorescence signal and the optical detector sensitivity. The cross-correlation enables the amplitude and phase shift of the fluorescence signal and hence the fluorophore lifetime to be measured.

For acousto-optic imaging, one can simply substitute the fluorescence signal in the FLIM example with the ultrasound-modulated light signal (albeit at 1 MHz not hundreds of MHz). Thus the amplitude, A , of the acousto-optic effect can be calculated directly from the following equation:

$$I = S_0 - S_{180}$$

$$Q = S_{90} - S_{270}$$

$$A = \sqrt{(I^2 + Q^2)}$$

where S_n is the CCD image acquired for a given phase-shift of n degrees.

For ultrasound-modulated incoherent light the photons are modulated in the US focal zone due to a modulation in the optical attenuation. Since photons then take different pathlengths from the US focal zone to the optical detector there are still residual phase differences in the resultant optical signal which could be corrected for with this technique. However, at 1MHz these phase differences were found to be negligible, especially compared to those typically found in standard frequency domain optical imaging using a modulated laser source and conducted at hundreds of MHz [6]. Hence, even without performing phase-alignment, the spatial integration of the signal from this large area detector is still a preferable and more efficient option for capturing the ultrasound-modulated photons than using a small area, single photodetector.

The experimental set-up for the gain-modulated image intensifier approach is shown in Fig. 6:

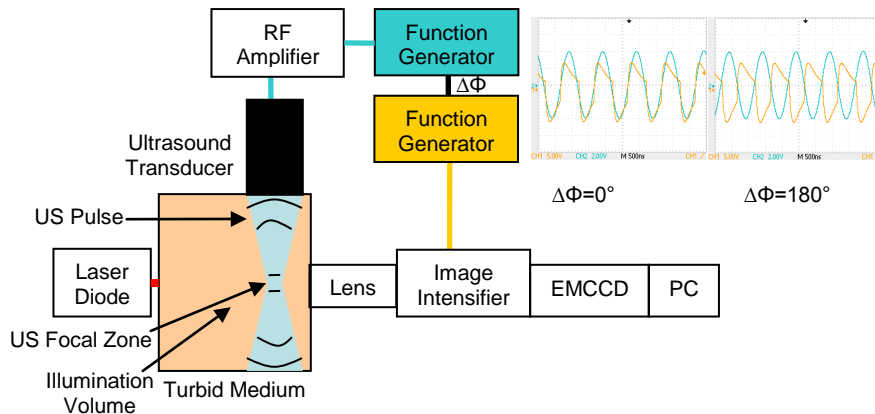

Figure 6. Experimental configuration for acousto-optic detection with gain-modulated image intensifier

The configuration is similar to that described in Figure 1, except that the extension tube has been removed since we now want to collect the optical signal over a much larger optical area (several cm^2) rather than focusing on individual speckles. Based on our previous experiments with the silicon photodiode we used the coherent source, rather than the halogen lamp, since it provided a more stable CW source. The coherence of

the source is not relevant here since we are not observing speckle contrast but rather the modulated photon intensity via ultrasound-modulation of the optical attenuation. Figure 6 shows the driving signals to the ultrasound (blue) and the image-intensifier (yellow) for the two cases of in phase ($\Delta\Phi=0^\circ$) and out of phase ($\Delta\Phi=180^\circ$). For quadrature detection, by definition, four phase measurements are generally required as described above. However, here we intentionally phase-aligned the signals for the special case that the maximum and minimum signals coincided with $\Delta\Phi=0^\circ$ and $\Delta\Phi=180^\circ$ respectively. As such, the amplitude of the acousto-optic effect is simply the difference between the two measurements. The image intensifier's microchannel plate (MCP) was set to a voltage of 260 V (low) and the CCD integration time was set to 320 ms per frame. Several images were then acquired for $\Delta\Phi=0^\circ$ before switching to $\Delta\Phi=180^\circ$ and finally with the ultrasound turned-off as a control. The resultant CCD images were then spatially integrated and the intensity values, I , are displayed in Fig 7:

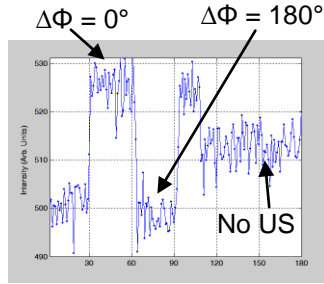

Figure 7: Detection of US-modulated photons with Gain-modulated image intensifier

This result clearly demonstrates that ultrasound-modulation causes a decrease in the local optical attenuation when $\Delta\Phi=0^\circ$ resulting in higher intensity, and an increase in the local optical attenuation when $\Delta\Phi=180^\circ$ resulting in lower intensity, compared to the local optical attenuation and intensity when no ultrasound is applied. Note, we still switched the detector's phase back and forth when no ultrasound was applied as a further control. Also, the intensity obtained without US being applied is midway between $\Delta\Phi=0^\circ$ and $\Delta\Phi=180^\circ$ as expected. The modulation in the optical intensity due to ultrasound can best be represented by the induced modulation depth, M , equal to $(I_{\Delta\Phi 0^\circ} - I_{\Delta\Phi 180^\circ}) / (I_{\Delta\Phi 0^\circ} + I_{\Delta\Phi 180^\circ})$ which here is approximately 3%.

This, to our knowledge, is the first detection of ultrasound-modulated photons using a gain-modulated image intensifier phase detection approach.

Ultrasound-Modulated Fluorescence

The detection of ultrasound-modulated fluorescence would promote acousto-optic imaging to acousto-optic molecular imaging with the use of targeted fluorophore-based optical probes. As mentioned above, fluorescence is an incoherent phenomenon and we had previously detected ultrasound-modulation of incoherent photons with the silicon photodetector (Fig. 3). However, this had employed a 100W halogen lamp which is many orders of magnitude brighter than a typical fluorescence signal, nW. Hence, although we did attempt it, it was not surprising that we were unable to detect a fluorescence signal with the silicon photodetector. Fluorescence detection usually requires a more sensitive optical detector, such as a photomultiplier tube (PMT) or microchannel plate (MCP), due to the low quantum yield of common fluorophores. To our knowledge only two other groups [7, 8] have recently reported on the detection of ultrasound-modulated fluorescence and both used a single detector as opposed to, and without the benefits of, our large area, multi-pixel image intensifier. We have previously used our image intensifier to detect time domain fluorescence signals[9] and now planned to use it to detect ultrasound-modulated fluorescence. We chose a small cylindrical fluorescent pellet, 15 mm diameter by 8 mm height, containing the fluorophore Qdot800 (Invitrogen, CA) at 10 pM concentration. Our manufacture of such pellets is reported elsewhere[10]. The fluorescent pellet was placed on the side of the water tank in the line of sight between the laser diode and optical detector to which we had added a wavelength filter (OmegaFilters) to block detection of the laser diode excitation light and permit detection of fluorescence from the fluorescent pellet (see Fig. 8).

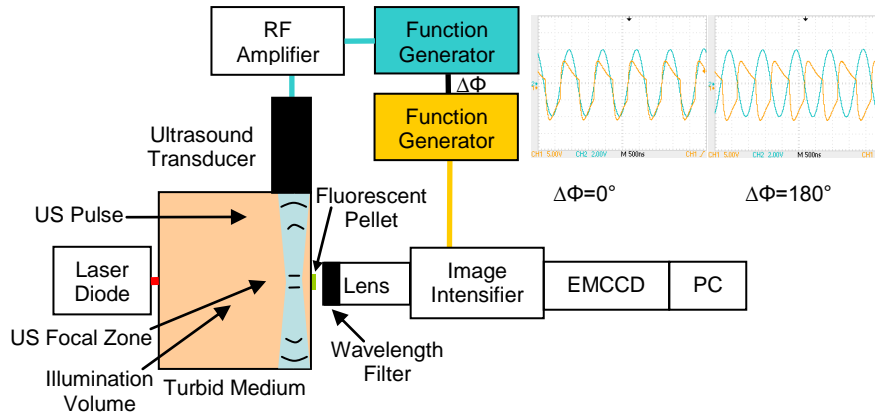

Figure 8: Experimental set-up for detection of ultrasound-modulated fluorescence

Due to the weak fluorescence signal we increased the MCP voltage to 510 V (medium) and acquired several images with an integration time of 320 ms at $\Delta\Phi=0^\circ$ before switching to $\Delta\Phi=180^\circ$. The resultant CCD images were then integrated and the intensity values are displayed in Fig 9:

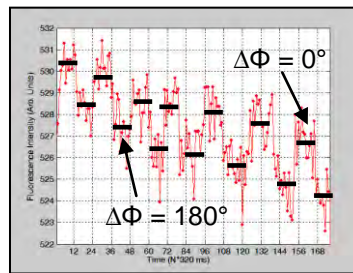

Figure 9: Detection of US-modulated fluorescence with Gain-modulated image intensifier

This result demonstrates the detection of ultrasound-modulated fluorescence with the gain-modulated image intensifier. Note the modulation depth is much weaker, approximately 0.2 %, compared to that measured from excitation photons (see Figure 7) and is expected since we now have a weaker fluorescence signal. Indeed, at these low light levels a systematic downwards drift in the detector's response is also evident. This is not a concern since simple data-processing can remove this baseline effect. As before, without the ultrasound being applied there was no modulation detected. It should be noted that the fluorescent pellet is actually located just after the ultrasound focal zone and closer to the detector to ensure a strong detected optical signal, rather than submerged within the focal zone itself. As such, the fluorescence photons are not being modulated per se, but rather the excitation photons from the laser diode are being modulated just before the pellet which then induces a modulation in the fluorescence signal. Indeed, even if the fluorescent pellet and focal zone were exactly co-localized the dominant modulation of the resultant fluorescence signal would be due to modulation of the excitation photons rather than modulation of the emitted fluorescence photons themselves. One can consider the continuous wave photons from the optical source forming a localized modulated optical source in the ultrasound focal zone which, when in close proximity of a fluorophore, generates a modulated fluorescence signal which would otherwise be a steady-state fluorescence signal. Hence, there is potential to image fluorophore distribution with ultrasound spatial resolution. It should be noted that a slight misalignment in the US focal zone proximity to the fluorescent pellet led to a total loss of the modulated fluorescence signal demonstrating that the method should provide a very high spatial resolution (~mm).

This, to our knowledge, is the first detection of ultrasound-modulated fluorescence photons using a gain-modulated image intensifier phase detection approach. We subsequently published these quadrature detection results in Open Optics[11].

Task 3. Prove that microbubble-based US contrast agents can increase the photon modulation and result in higher SNR in regions containing microbubbles.

This highly innovative and novel approach addresses the major problem of acousto-optic imaging, namely the very low signal from modulated photons in the overwhelming presence of un-modulated photons which has hindered its translation to high optical scattering in vivo applications. We present the modulation of microbubbles by ultrasound, which is known to induce large oscillatory volumes changes of the microbubbles [12], which here we expect to dramatically increase the photon modulation due to large modulation of the local optical properties. To test this hypothesis we modified the experimental set-up shown in figure 2a by submerging a quartz cuvette (12.5x12.5x68mm) in the US focal zone of a 2.25 MHz transducer driven at 1.5 MHz. We also prepared Definity (FDA approved US contrast agent, Bristol-Myers Squibb Medical Imaging) per manufacturer’s instruction and then filled a 1-mL syringe and allowed the microbubbles to settle. By obtaining samples from the syringe at different depths we obtained three suspensions of small (least buoyant) ~1 μ m, medium ~2 μ m, and large (most buoyant) ~3 μ m microbubbles. Each microbubble suspension was placed in the cuvette individually and the corresponding AO signal measured. Between different suspensions the cuvette was washed thoroughly with pure saline for which we also measured the AO signal as a control. Fig. 10a shows the detected AO modulation in the frequency domain where it can be seen that there is a significant increase in the photon modulation at the fundamental frequency (1.5 MHz) for all microbubble suspensions compared to the saline. Furthermore, higher order harmonics are observed at 3 and 4.5MHz for the medium and large microbubbles. Fig. 10b quantifies the significant dB gain of the modulated photons beyond the saline control by the addition of microbubbles.

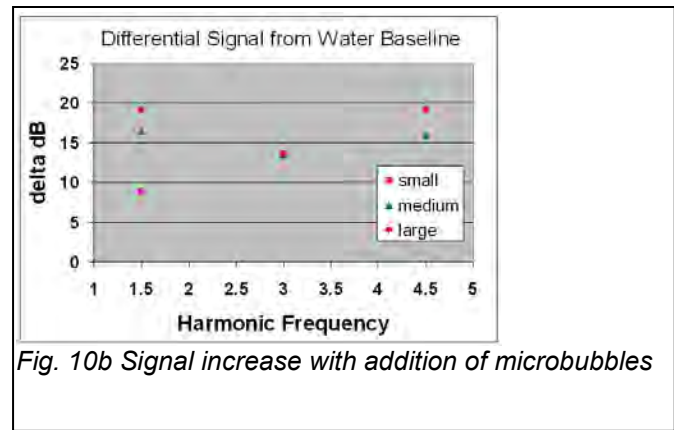
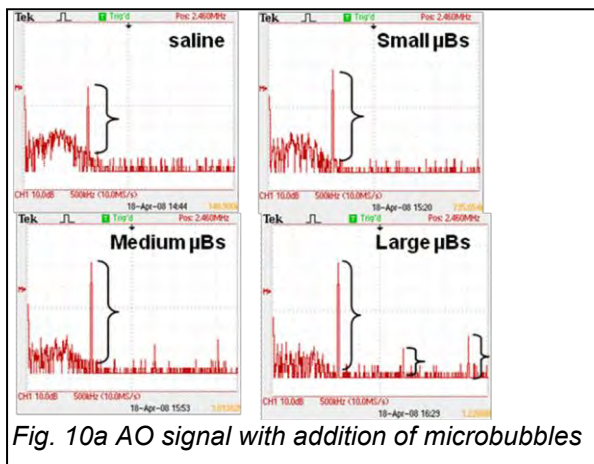

This, to our knowledge, is the first demonstration of the ultrasound-modulated photon signal being amplified by microbubbles and the additional modulation at higher harmonics. This harmonic signature can be used to specifically identify the microbubbles.

Through collaboration with the Electrical and Computer Engineering department at UCSD we also explored using their novel photon detector technology, known as a single photon avalanche diode (SPAD) detector [13], to detect ultrasound-modulated photons. We used the experimental setup in Fig. 2a and replaced the silicon photo-detector, amplifier, high-pass filter, and scope with a 7- μ m SPAD, counter and computer to display photon counts over time. We also used a 5mW, 532nm laser given this SPAD is more sensitive at these shorter wavelengths. Despite the SPAD’s small detection area (7- μ m) we were able to clearly detect the modulated optical signal in the SPAD’s time-of-arrival count histogram (Fig. 11a). A Fourier transform of this signal (Fig. 11b) shows the expected peak at 1 MHz (the US frequency). In principle, the larger active area of a 2D SPAD array should capture many more photons increasing SNR.

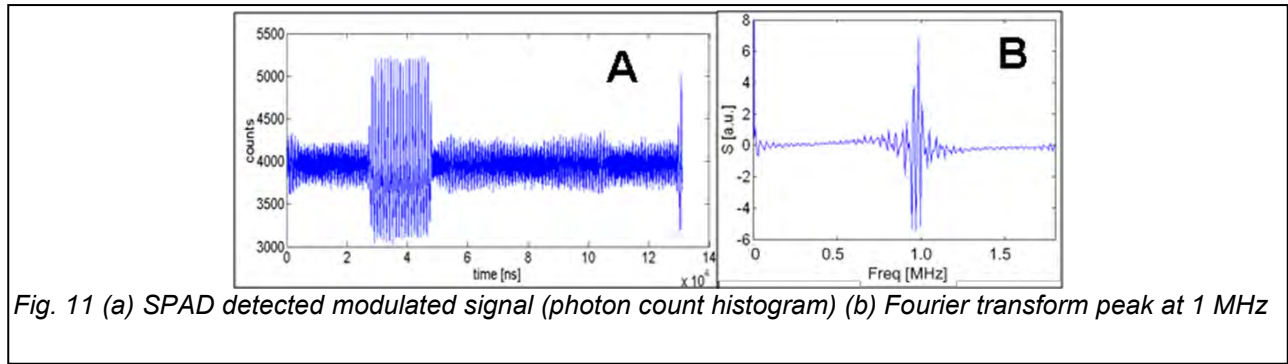

Fig. 11 (a) SPAD detected modulated signal (photon count histogram) (b) Fourier transform peak at 1 MHz

This, to our knowledge, is the first detection of ultrasound-modulated photons with a SPAD. The microbubble and SPAD results was recently presented[14, 15] and published in the SPIE proceedings[15].

Task 4. Prove that fluorophores attached to microbubbles will result in modulation of the photons at the emission frequency.

As presented in task 2, we have already demonstrated the detection of ultrasound-modulated photons at the fluorescence emission frequency[4, 11] and now plan to develop and employ fluorophore-based microbubbles. To this end, Dr. Goodwin, a UCSD colleague in the Nanoengineering department, recently labeled microbubbles with the fluorophore Nile Red (Invitrogen, CA). Figure 12 shows a fluorescence microscope image of these fluorescent microbubbles.

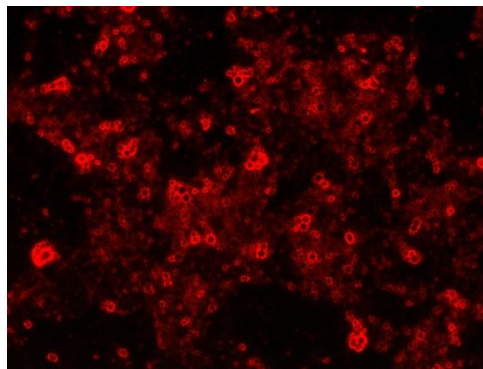

Fig. 12 Microscope image of fluorophore-labeled microbubbles

Next steps were to optimize the fluorescent microbubble formulation and demonstrate pressure modulation (ultimately via ultrasound) of the microbubbles to change their size to induce self-quenching of the fluorophore to modulate the fluorescence intensity. Since task 3 demonstrated that microbubbles also generate higher harmonic modulations we also expect to detect these higher harmonic modulations in the fluorescence signal. Ultimately, we want to detect the ultrasound-modulation of fluorescence from fluorescent microbubbles in tissue-like media to demonstrate this approach is viable for in vivo applications.

Third Year

The final task of the project is as follows:

Task 4. Prove that fluorophores attached to microbubbles will result in modulation of the photons at the emission frequency.

This is the most ambitious aspect of the project and has also proved the most challenging to date. Earlier in the project we demonstrated both the detection of ultrasound-modulated fluorescence (without microbubbles) and that microbubbles (without fluorescence) can significantly enhance the ultrasound-modulated photon signal with characteristic harmonic signatures. However, combining both fluorescence and microbubbles to significantly enhance the ultrasound-modulated fluorescence with characteristic harmonic signatures has remained elusive.

One major issue has been obtaining robust and repeatable measurements of ultrasound-modulated photons enhanced with microbubbles. Consequently, the third year of this project was spent redesigning and improving our acousto-optic set-up to obtain robust and repeatable measurements from microbubbles. Collaboration with UCSD colleagues, particularly Mark Hsu, Ph.D. student, ECE Dept. and Dr. Eghtedari, Resident, Radiology Dept., led to the development of a novel light scattering system which can measure the ultrasound-modulated dynamics of individual microbubbles (Figure 13):

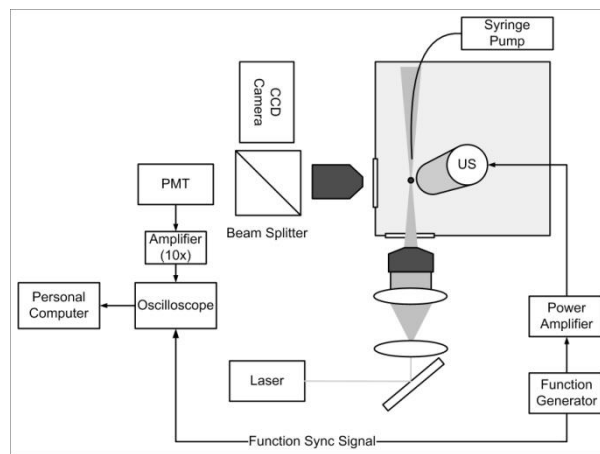

Fig. 13 Acousto-Optic Light Scattering system

In essence, an individual microbubble in a water-bath is illuminated by a laser beam and the scattered light is detected by a PMT. Ultrasound-modulation of the microbubble changes its diameter which changes the amount of scattered light detected by the PMT. The PMT output is amplified and recorded on an oscilloscope which is synchronized to the ultrasound-modulation. Microbubbles are appropriately diluted such that a syringe pump and capillary tube introduce an individual microbubble into the acousto-optic focal per ultrasound pulse train which is confirmed with a CCD camera. Hence, the light scattering signal can characterize the ultrasound-induced oscillatory dynamics of individual microbubbles in real-time.

The light scattering system was employed to measure the ultrasound-induced oscillatory dynamics from a variety of microbubbles and did so in a robust and repeatable manner. Specifically, commercial Definity microbubbles were compared to more rigid-shelled bovine serum albumin microbubbles prepared by UCSD colleague Dr. Goodwin. Commercial solid silica microspheres were used as a control due to their inability to undergo ultrasound-induced oscillations at these diagnostic ultrasound pressures.

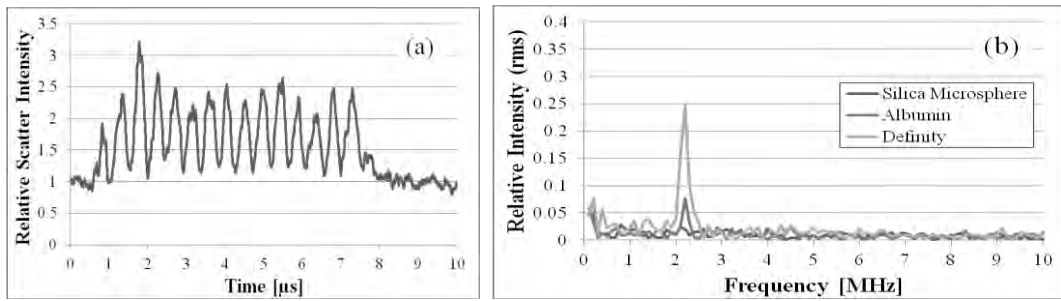

Fig. 14 Time domain (a) and Fourier Domain (b) waveforms from different microbubbles undergoing ultrasound-induced oscillation at 100 kPa

Figure 14a shows the time domain waveform of light scattering from Definity microbubbles undergoing an ultrasound pulse train (fifteen 2.25 MHz pulses at 100 kPa). Figure 14b shows the corresponding Fourier transform clearly identifying the 2.25 MHz fundamental frequency. Figure 14b also shows the response for the albumin microbubbles which have a smaller amplitude at 2.25 MHz compared to the Definity microbubbles. This is expected since the albumin microbubbles have a more rigid shell which dampens the oscillation. Figure 14b also shows the silica microspheres which exhibit no oscillation as expected.

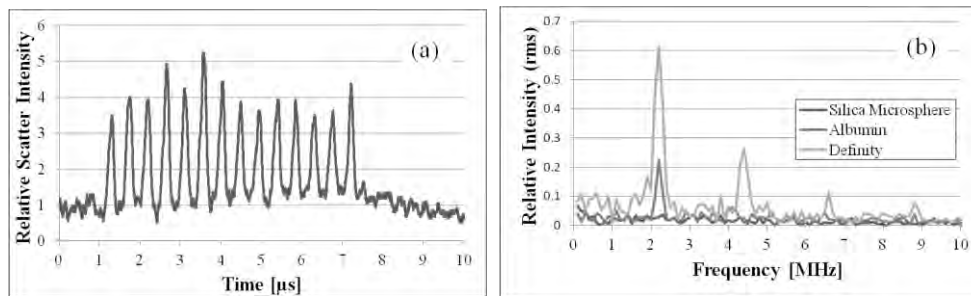

Fig. 15 Time domain (a) and Fourier Domain (b) waveforms from different microbubbles undergoing ultrasound-induced oscillation at 200 kPa

Figure 15 shows similar results to Figure 14 but with an increased ultrasound pressure of 200 kPa. Here we see the emergence of higher harmonics for the Definity microbubbles but not for the more rigid-shelled albumin microbubbles. Again, the silica microspheres exhibit no oscillation as expected.

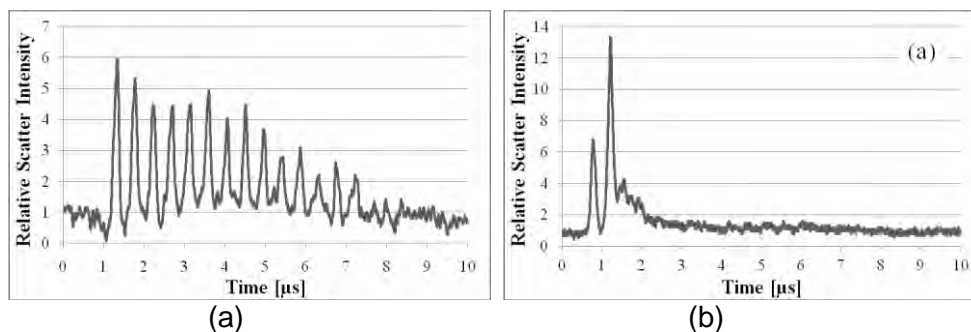

Fig. 16 Time domain waveform showing Definity microbubble collapse at 260 kPa (a) and implosion at 1.3 MPa (b)

Figure 16a shows Definity microbubble oscillations at 260 kPa. Here we observe that the oscillations become increasingly damped with time. Here we speculate that at this increased pressure the shell is compromised and small amounts of gas escape the microbubble with each oscillation reducing its ability to oscillate. Figure 16b shows a Definity microbubble implosion at 1.3 MPa as expected. These results from the acousto-optic light scattering system were recently accepted for publication in the Journal of Biomedical Optics, Hsu et al [16] *In Press*. The development of the acousto-optic light scattering system in the third year means we can now robustly measure and characterize the harmonic signature from a variety of microbubbles.

Fourth Year

To complete the final Task 4 of this Project we returned to the issue of fluorescent microbubbles and the detection of their ultrasound-modulated fluorescence.

The goal was to load fluorophore on the microbubble surface such that under radial oscillation of the microbubble by ultrasound the fluorophore undergoes modulated quenching resulting in a modulated fluorescence signal at the ultrasound frequency. Ideally, this would vary from no fluorescence (fully quenched) to maximum fluorescence (fully unquenched) to no fluorescence (fully quenched) following microbubble expansion and contraction over an ultrasound cycle as shown in Figure 17.

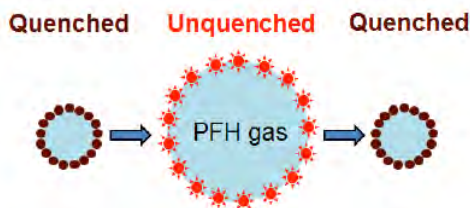

Fig. 17 Concept of Quenchable Fluorescent Microbubble

Manufacture of quenchable fluorescent microbubbles was conducted by Mr. M. Benchimol in the ECE department at UCSD. Fluorescent microbubbles were prepared using variations of published microbubble preparations using DSPC, DSPE-mPEG, and perfluorohexane (PFH) gas in PBS. A lipophilic fluorescence dye (DiI) was added during microbubble fabrication to be incorporated into the lipid shell.

The acousto-optic light scattering system (Fig. 13) was modified by the addition of emission filters in front of the PMT for the detection of DiI fluorescence. Figure 18a shows the system's time domain detection of ultrasound-modulated fluorescence from these quenchable fluorescent microbubbles (blue) compared to non-fluorescent microbubbles as controls (red). Figure 18b shows the corresponding Fourier Transform with a characteristic peak in the fluorescence signal at the ultrasound-modulation frequency.

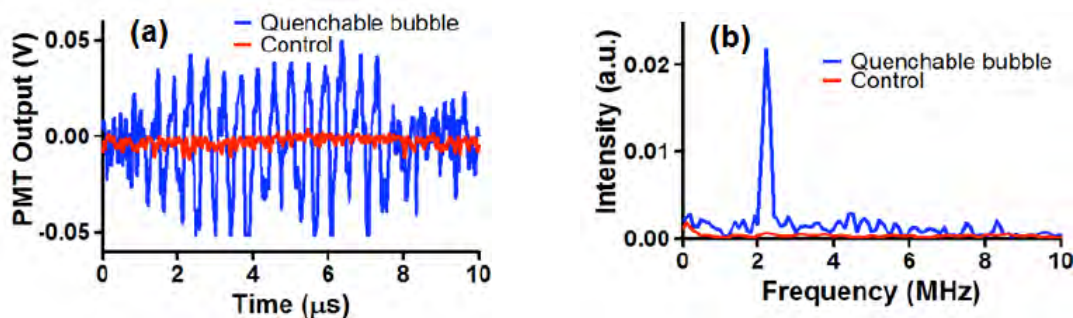

Fig. 18 Detection of ultrasound-modulated fluorescence from quenchable fluorescent microbubbles

This result completes the final task of the project. Such quenchable fluorescent microbubbles have potential applications as contrast agents for in vivo acousto-optic imaging.

KEY RESEARCH ACCOMPLISHMENTS

First Year

1. Detection of ultrasound-modulated incoherent photons.
2. Novel quadrature detection of ultrasound-modulated photons with a gain-modulated image-intensified CCD.
3. Novel quadrature detection of ultrasound-modulated fluorescence photons with a gain-modulated image-intensified CCD.

Second Year

4. Significant increase of ultrasound-modulated photons with microbubbles.
5. Generation of higher harmonic ultrasound-modulated photons with microbubbles.
6. Detection of ultrasound-modulated photons with SPAD detector.

Third Year

7. Development of acousto-optic light scattering system.
8. Robust characterization of ultrasound-induced oscillation of individual microbubbles in real-time.
9. Observation of microbubble collapse and implosion at higher ultrasound pressures.

Fourth Year

10. Manufacture of quenchable fluorescent microbubbles.
11. Detection of ultrasound-modulated fluorescence from quenchable fluorescent microbubbles.

REPORTABLE OUTCOMES

Publications, Presentations, and Patent Applications:

First Year

D. J. Hall and U. Sunar, *A novel acousto-optic molecular imaging system for fluorescence-based probes*. Joint (SMI&AMI) Molecular Imaging Conference, Oral Presentation 0070, (2007). (Triple blind peer-review scored as one of the Top Ten conference abstracts out of ~1000 presentations).

Second Year

D. J. Hall, U. Sunar, and S. Farshchi-Heydari, "Quadrature detection of ultrasound-modulated photons with a gain-modulated, image-intensified, CCD camera" *Open Optics 2*, 75-78 (2008). (see Appendix for paper).

M. Hsu, D. J. Hall, S. Farshchi-Heydari, S. Esener, and R. F. Mattrey, "Novel Acousto-Optic Signal Augmentation using Microbubbles," Poster Presentation 0366, WMI (2008).

D. J. Hall, M. Hsu, S. Esener, and R. F. Mattrey, "Detection of ultrasound-modulated photons and enhancement with ultrasound microbubbles," *Proc. SPIE, Vol. 7177, 71771L* (2009). (see Appendix for paper).

Patent Application, D. J. Hall, "Detection of ultrasound-modulated photons with a gain-modulated image-intensified CCD camera," (2008).

Patent Application, D. J. Hall and R. F. Mattrey, "Enhancement of Acousto-Optic Signal Using Microbubbles," (2008).

Fourth Year

D. J. Hall, M. J. Hsu, A. Goodwin, M. Eghtedari, S. Esener, and R. F. Mattrey, "Feasibility of Dual Optics-Ultrasound Imaging and Contrast Media for the Detection and Characterization of Prostate Cancer," Poster Presentation P21-27, IMPaCT (2011) (see Appendix for Abstract).

M. J. Hsu, M. Eghtedari, A. Goodwin, D. J. Hall, R. F. Mattrey, S. C. Esener, "Characterization of Individual Ultrasound Microbubble Dynamics with a Light Scattering System," *Journal of Biomedical Optics* (2011) *In Press*

Grants Applied for:

First Year

NIH: U54 RFA-CA-08-002 NTR: Optical Imaging in Multimodal Platforms.

"High Resolution Optical-Ultrasound (OPUS 1) Molecular Imaging in Breast Cancer

R. Mattrey and D. Hall (Co-PIs). Employed research supported by this award as Preliminary Data.

Second Year

NIH: R01 PAR07-214: Academic-Industrial Partnerships for Development and Validation of In Vivo Imaging Systems and Methods for Cancer Investigations.

“Development of Dual Optics/Ultrasound (OPUS) Imaging System and its Contrast Media”

R. Mattrey and D. Hall (Co-PIs). Employed research supported by this award as Preliminary Data.

Third Year

NIH: RC1 EB010994-01: Broad Challenge Area (06): *Enabling Technologies* and specific Challenge Topic, 06-EB-106 *Optical Imaging of Internal Organs in Humans*. “Acousto-Optic Imaging of Internal organs”

D. Hall (PI). Employed research supported by this award as Preliminary Data.

Fourth Year

NIH: R21

“Fluorescent Microbubbles as High-Resolution Acousto-optic Contrast Agents for Breast Cancer Diagnosis”

R. Mattrey (PI), D. Hall (Co-I). Employed research supported by this award as Preliminary Data.

CONCLUSION

The first year of this research project involved the detection of ultrasound-modulated incoherent photons, based on the principle of modulating the optical attenuation, followed by the novel quadrature detection of ultrasound-modulated photons and fluorescence photons with a gain-modulated image intensified CCD. This research demonstrates the potential to perform acousto-optic imaging with incoherent and fluorescence photons providing novel opportunities for in vivo acousto-optic molecular imaging based on endogenous contrast and fluorescent probes. This cutting-edge research was presented at the Joint Molecular Imaging conference[4] and peer-review rated as one of the top ten abstracts out of ~1000 presentations. This work was subsequently recently published in *Open Optics*[11] with a corresponding patent application.

In the second year of this research project we demonstrated that microbubbles dramatically enhance AO photon modulation at both the fundamental and higher order harmonic frequencies. This signal enhancement should greatly improve detection of ultrasound-modulated photons especially for challenging, highly scattering, in vivo environments. Furthermore, the specific harmonic signature of microbubbles will help identify and discriminate them from ultrasound-modulation of native tissue optical properties leading to high specificity with targeted microbubbles. Moreover, ultrasound-modulated fluorescence from fluorophores in the vicinity (or attached) to microbubbles should also be encoded with their harmonic signature thus differentiating them from fluorophores not in the vicinity of microbubbles. A corresponding patent application has been filed. Meanwhile, novel detection of ultrasound-modulated photons with a SPAD, through collaboration with the UCSD ECE department, offers the potential for high photon count rate, sensitivity, and large sampling area from future 2D SPAD arrays to provide strong signal for in vivo AO detection of ultrasound-modulated photons with clinically-viable acquisition times. The above results were presented[14, 15] and recently published[15] in the SPIE proceedings.

In the third year of this research project we developed a novel acousto-optic light scattering system to address difficulties in obtaining stable measurements of ultrasound-modulated photons enhanced with microbubbles. The system was employed to characterize ultrasound-induced oscillation of individual microbubbles in real-time and did so in a robust and repeatable manner. The system was also employed to observe microbubble collapse and implosion at higher ultrasound pressures. This research is now *In Press* [16].

In the fourth and final year of this research project we manufactured quenchable fluorescent microbubbles and measured their ultrasound-modulated fluorescence with the acousto-optic light scattering system.

As such, this project was an overall success with all tasks completed. The final results from this project were presented at the Innovative Minds in Prostate Cancer Today (IMPACT) conference (March 2011, Orlando, FL) [17]. Ultimately, in vivo acousto-optic imaging has the potential to diagnose prostate cancer at ultrasound spatial resolution based on optical contrast of endogenous hypoxia with microbubbles or quenchable fluorescent microbubbles for additional enhancement.

REFERENCES

- [1] L. V. Wang, "Ultrasound-mediated biophotonic imaging: a review of acousto-optical tomography and photo-acoustic tomography," *Dis Markers*, vol. 19, pp. 123-38, 2003.
- [2] J. Li, G. Ku, and L. H. Wang, "Ultrasound-modulated optical tomography of biological tissue by use of contrast of laser speckles," *Appl. Opt.*, vol. 41, pp. 6030-6035, 2002.
- [3] P. van der Zee, M. Cope, S. R. Arridge, M. Essenpreis, L. A. Potter, A. D. Edwards, J. S. Wyatt, D. C. McCormick, S. C. Roth, E. O. Reynolds, and D. T. Delpy, "Experimentally measured optical pathlengths for the adult head, calf, and forearm and the head of the newborn infant as a function of interoptode spacing," *Adv. Exp. Med. Biol.*, vol. 316, 1992.
- [4] D. J. Hall and U. Sunar, "A novel acousto-optic molecular imaging system for fluorescence-based probes," *SMI&AMI*, 2007.
- [5] K. Stoop, a. a, b. b, c. c, and d. d, "LIFA: System for fluorescence lifetime imaging microscopy (FLIM)," *EMBO:Light Microscopy of Living Specimens*, 2002.
- [6] A. B. Thompson and E. M. Sevick-Muraca, "Near-Infrared fluorescence contrast-enhanced imaging with intensified charge-coupled device homodyne detection: measurement precision and accuracy," *JBO*, vol. 8, pp. 111-120, 2003.
- [7] K. Krishnan, B. Fomitchov, S. Lomnes, M. Kollegal, and F. Jansen, "A theory for the ultrasonic modulation of incoherent light in turbid medium," *SPIE*, vol. 6009, pp. 60090V1-V12, 2005.
- [8] M. Kobayashi, T. Mizumoto, Y. Shibuya, and M. Enomoto, "Fluorescence tomography in turbid media based on acousto-optic modulation imaging," *Appl. Phys. Letters*, vol. 89, pp. 181102:1-3, 2006.
- [9] D. Hall, D. R. Vera, and R. F. Mattrey, "Full-field time domain optical molecular imaging system," *SPIE* 5693, 2005.
- [10] D. Hall and S. Han, "Preliminary Results from a Multi-wavelength time Domain Optical Molecular Imaging System," *SPIE*, vol. 6430, 2007.
- [11] D. J. Hall, U. Sunar, and Farshchi-Heydari, "Quadrature detection of ultrasound-modulated photons with a gain-modulated, image-intensified, CCD camera," *Open Optics*, vol. 2, pp. 75-78, 2008.
- [12] N. de Jong, A. Bouakaz, and P. Frinking, "Basic Acoustic Properties of Microbubbles," *Echoradiography*, vol. 19, pp. 229-240, 2002.
- [13] H. Finkelstein, M. J. Hsu, and S. C. Esener, "STI-bounded single-photon avalanche diode in a deep-submicrometer CMOS technology," *IEEE Electron Device Letters*, vol. 27, pp. 887-889, 2006.
- [14] M. Hsu, D. J. Hall, S. Farshchi-Heydari, S. Esener, and R. F. Mattrey, "Novel Acousto-Optic Signal Augmentation using Microbubbles," *Poster Presentation - 0366*, WMI, 2008.
- [15] D. J. Hall, M. Hsu, S. Esener, and R. F. Mattrey, "Detection of ultrasound-modulated photons and enhancement with ultrasound microbubbles," *Proc. SPIE*, vol. 7177, pp. 71771L, 2009.
- [16] M. J. Hsu, M. Eghtedari, A. Goodwin, D. J. Hall, R. F. Mattrey, S. C. Esener, "Characterization of Individual Ultrasound Microbubble Dynamics with a Light Scattering System," *JBO 2011 In Press*
- [17] D. J. Hall, M. J. Hsu, A. Goodwin, M. Eghtedari, S. Esener, and R. F. Mattrey, "Feasibility of Dual Optics Ultrasound Imaging and Contrast Media for the Detection and Characterization of Prostate Cancer," *IMPACT conference, Poster Presentation P21-27*, 2011.

FUNDED PERSONNEL

D. J. Hall, Ph.D. (PI), R. F. Mattrey, M.D. (Radiologist), U. Sunar, Ph.D. (Postdoc), D. Fisher (Chemist).

APPENDICES

Page 19:

D. J. Hall, U. Sunar, and S. Farshchi-Heydari, "Quadrature detection of ultrasound-modulated photons with a gain-modulated, image-intensified, CCD camera" *Open Optics 2*, 75-78 (2008).

Page 23:

D. J. Hall, M. Hsu, S. Esener, and R. F. Mattrey, "Detection of ultrasound-modulated photons and enhancement with ultrasound microbubbles," *Proc. SPIE, Vol. 7177, 71771L* (2009).

Page 28:

D. J. Hall, M. J. Hsu, A. Goodwin, M. Eghtedari, S. Esener, and R. F. Mattrey, "Feasibility of Dual Optics Ultrasound Imaging and Contrast Media for the Detection and Characterization of Prostate Cancer," *IMPACT conference, Poster Presentation P21-27* (2011).

Quadrature Detection of Ultrasound-Modulated Photons with a Gain-Modulated, Image-Intensified, CCD Camera

David J. Hall*, Ulas Sunar and Salman Farshchi-Heydari

Department of Radiology, University of California, San Diego, CA 92093-0819, USA

Abstract: Acousto-optic imaging promises to provide *in vivo* images of optical contrast but with the superior spatial resolution of ultrasound imaging. Here we present novel quadrature detection of ultrasound-modulated photons with a gain-modulated, image-intensified, CCD camera. The additional detection of ultrasound-modulated fluorescence photons demonstrates potential for *in vivo* acousto-optic molecular imaging.

Keywords: Acousto-optic, fluorescence, ultrasound.

INTRODUCTION

In the last several years there has been rapid growth in the optical molecular imaging of small animals *in vivo* [1]. Longitudinal studies can now be performed employing optical probes based on bioluminescence and fluorescence markers [2]. Nevertheless, optical imaging suffers from the inherent high scattering of optical photons by biological tissue resulting in centimeter spatial resolution for applications such as optical breast imaging [3]. To address this issue researchers are combining optics and ultrasound to provide optical images at superior ultrasound spatial resolution (mm). One popular approach is opto-acoustic imaging [4] which provides optical absorption images at ultrasound resolution. An alternative combination of optics and ultrasound is acousto-optic imaging [5]. This approach involves the modulation of photons, at the ultrasound frequency, which propagate through a small ultrasound focal zone. Optical images generated from only these ultrasound-modulated photons will thus have the improved spatial resolution of the ultrasound focal zone. The main challenge is the detection and discrimination of ultrasound-modulated photons from the overwhelming presence of non-modulated photons not passing through the ultrasound focal zone. To date, most researchers have employed coherent light sources and detecting ultrasound-modulated speckles [6, 7]. To increase the SNR of the modulated signal a large number of speckles must be detected. However, since the detected speckles modulate at the same frequency but with random phase, a direct spatial integration of the speckles would lead to a loss of modulation. Instead, parallel detection techniques employ a coherent light source modulated at the ultrasound frequency and detect the ultrasound-modulated speckles with a CCD camera [8]. Quadrature detection, i.e. acquiring CCD images of speckles at four different phase shifts between the laser and ultrasound modulation, permits the modulation amplitude of each speckle to be determined which summed

over all speckles leads to an increase in SNR. Researchers have also elucidated on the physical process of ultrasound-modulation of coherent photons [9, 10]. The requirement for coherence limits the choice of light sources to those with a coherence length at least as long as the optical pathlength (several centimeters for highly scattering biological tissue), as well as high imaging spatial resolution (order of microns) to resolve individual speckles, and prohibits the modulation of incoherent processes such as fluorescence.

More recently researchers have reported detection of ultrasound-modulated incoherent photons [11]. Here, the ultrasound modulates the optical properties (refractive index, absorption, scattering) of the ultrasound focal zone resulting in a modulation of the local optical attenuation coefficient causing an in-phase intensity modulation of the photons (be they incoherent or coherent). In essence, it can be considered as generating a modulated light source at the ultrasound frequency in the focal zone. The detection of the in-phase intensity modulation does not require the high imaging spatial resolution needed to resolve the random phase speckles from coherent photons and permits direct spatial integration of the detected photons. Here we present our novel parallel detection approach and preliminary results demonstrating detection of ultrasound-modulated photons and fluorescence.

METHOD

The detection of ultrasound-modulated photons has employed photomultiplier tubes (PMTs) which have adequate bandwidth to measure the MHz modulation frequency but limited detection area. Unfortunately larger area detectors, such as CCD cameras, have inadequate frame rates (Hz) to capture the MHz signal. However, CCD cameras have been employed in parallel detection quadrature methods by cross-correlating the ultrasound modulation with a laser modulated at the ultrasound frequency and acquiring CCD images at four different phase shifts [8]. We have developed an alternative, novel, parallel quadrature detection approach where the laser is steady-state and the ultrasound modulation is cross-correlated with an image-intensified CCD camera which is gain-modulated at the ultrasound frequency and CCD images are acquired at four different phase shifts. In

*Address correspondence to this author at the Department of Radiology, University of California, San Diego, CA 92093-0819, USA;
E-mail: djhall@ucsd.edu

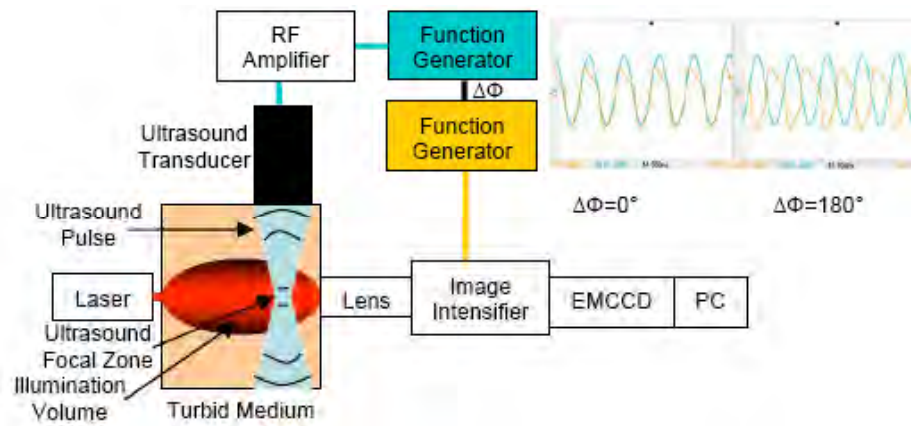

Fig. (1). Configuration for detection of ultrasound-modulated photons with a gain-modulated, image-intensified, CCD camera. 1 MHz driving signals for US transducer and Image Intensifier gain shown (top right) for relative phase shifts of 0° and 180° .

other words, we are cross-correlating the ultrasound and the optical detector using a steady-state source as opposed to cross-correlating the ultrasound and the optical source using a steady-state detector [8]. The experimental configuration is shown in Fig. (1).

In this setup we employed a laser diode (5 mW at 650 nm) to illuminate a water tank (65 mm wide) to which we added varying amounts of intralipid as an optical scatterer. Light was detected with a gain-modulated image intensifier (Picostar HRI, LaVision, Germany) with a highly sensitive electron-multiplying CCD camera (Andor, CA) to detect the output of the image intensifier and store it on the acquisition computer. Modulation of the image intensifier gain was achieved with a function generator (Stanford Research Systems, DS345) outputting a sine wave at the ultrasound frequency and phase-locked to a second identical function generator input to an RF Amplifier (ENI, 240L) to drive a single-element ultrasound transducer (Panametrics, V303) with a 1 MHz sine wave (50 Vpp) with 20 pulses (20 μ s pulse-length) every millisecond (2% duty cycle). The phase shift, $\Delta\Phi$, between the image intensifier gain and ultrasound transducer can be varied from 0 to 2π . Fig. (1) shows the driving signals for the image intensifier gain (yellow) and the ultrasound transducer (blue) for the two conditions of $\Delta\Phi=0^\circ$ and $\Delta\Phi=180^\circ$. The ultrasound transducer was submerged in the water tank such that its focal zone (100 KPa peak pressure) intercepted the line-of-sight between the laser diode (~ 0.1 mW in focal zone) and the image intensifier in transmission mode. A 50 mm f/1.4 Lens (Nikon) permitted photon detection over a large area (several cm^2).

RESULTS

Quadrature Detection of Ultrasound-Modulated Photons

The image intensifier's microchannel plate (MCP) was set to a voltage of 260 V (low gain) and the CCD integration time was set to 320 ms per frame. Several images were then acquired for $\Delta\Phi=0^\circ$ before switching to $\Delta\Phi=180^\circ$ and finally with the ultrasound turned-off as a control. For quadrature detection we generally require four phase measurements. However, here we intentionally phase-aligned the signals for the special case that the maximum and minimum signals coincided with $\Delta\Phi=0^\circ$ and $\Delta\Phi=180^\circ$ respectively. As such, the amplitude of the acousto-optic effect is simply the differ-

ence between the two measurements. Each CCD image was spatially integrated, since the intensity modulation was in-phase, and the intensity values, I , were plotted (Fig. 2). Note, similar to other researchers [8], this approach would also be applicable to parallel quadrature detection of ultrasound-modulated speckles from coherent photons.

Fig. (2) shows that ultrasound-modulation causes a decrease in the local optical attenuation when $\Delta\Phi=0^\circ$ resulting in higher intensity, and an increase in the local optical attenuation when $\Delta\Phi=180^\circ$ resulting in lower intensity, compared to the local optical attenuation and intensity when no ultrasound is applied. We continued to switch the detector's phase back and forth when no ultrasound was applied as a further control. Also it was noted that the intensity obtained without ultrasound being applied is midway between $\Delta\Phi=0^\circ$ and $\Delta\Phi=180^\circ$ as expected. The modulation in the optical intensity due to ultrasound can best be represented by the induced modulation depth, M , equal to $(I\Delta\Phi 0^\circ - I\Delta\Phi 180^\circ)/(I\Delta\Phi 0^\circ + I\Delta\Phi 180^\circ)$ which here is approximately 3%.

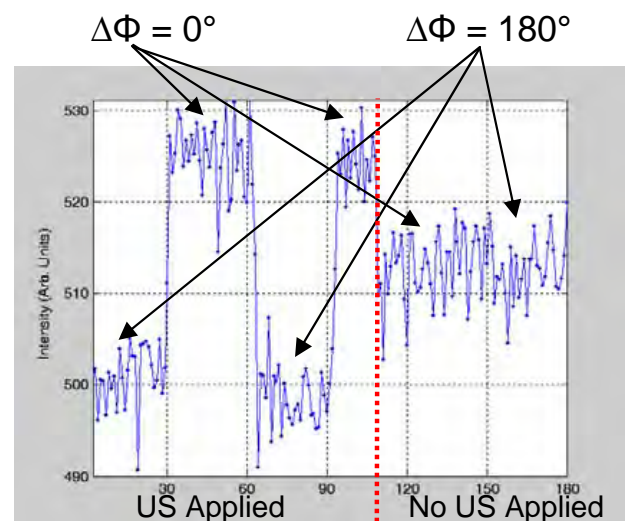

Fig. (2). Detection of ultrasound-modulated photons with 3 % modulation depth. Recorded Intensity for relative phase shifts of 0° and 180° with and without ultrasound applied.

Quadrature Detection of Ultrasound-Modulated Fluorescence

To investigate whether we could detect ultrasound-modulated fluorescence we used a small cylindrical fluorescent pellet, 15 mm diameter by 8 mm height, containing the fluorophore Qdot800 (Invitrogen, CA) at 10 pM concentration. Our manufacture of such pellets is reported elsewhere [12]. The fluorescent pellet was placed on the side of the water tank in the line of sight between the laser diode and optical detector to which we had added a wavelength filter (OmegaFilters, 780 LP) to block laser excitation light and permit detection of fluorescence from the fluorescent pellet. Due to the weak fluorescence signal we increased the MCP voltage to 510 V (medium gain) and acquired several images with an integration time of 320 ms at $\Delta\Phi=0^\circ$ before switching to $\Delta\Phi=180^\circ$. The resultant CCD images were then integrated and the intensity values are displayed in Fig. (3).

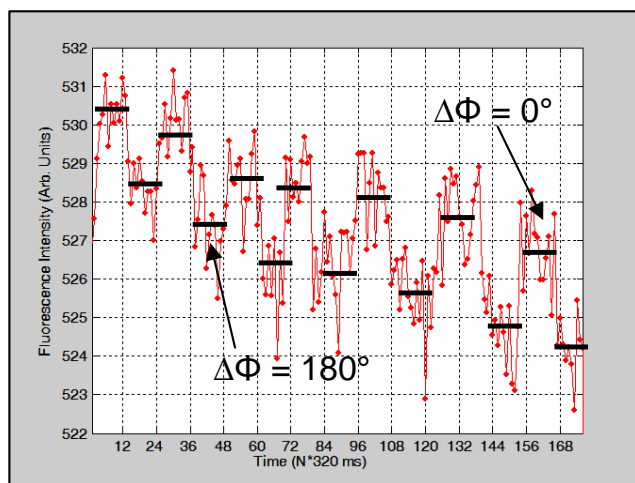

Fig. (3). Detection of ultrasound-modulated fluorescence. Recorded Fluorescence Intensity for relative phase shifts of 0° (peaks) and 180° (troughs).

This result demonstrates the detection of ultrasound-modulated fluorescence with the gain-modulated image intensifier. Note the modulation depth is much weaker, approximately 0.2 %, compared to that measured from excitation photons (Fig. 2). Systematic downwards drift is due primarily to small laser and detector drifts we observed during our measurements with and without ultrasound modulation. This drift was not a concern since modulation depth was the main interest and simple data-processing can remove this baseline effect. As before, without the ultrasound being applied there was no modulation detected. It should be noted that the fluorescent pellet is actually located just after the ultrasound focal zone and closer to the detector to ensure a strong detected optical signal, rather than submerged within the focal zone itself. As such, the fluorescence photons are not being modulated per se, but rather the excitation photons from the laser diode are being modulated just before the pellet which then induces a modulation in the fluorescence signal. Indeed, even if the fluorescent pellet and focal zone were exactly co-localized the fluorescence modulation would be due to modulation of both the excitation photons and emitted fluorescence photons. Again it is useful to consider the continuous wave photons from the optical source as forming a localized modulated optical source in the ultra-

sound focal zone which, when in close proximity of a fluorophore, generates a modulated fluorescence signal which would otherwise be a steady-state fluorescence signal. Hence, there is potential to image fluorophore distribution with ultrasound spatial resolution. It should be noted that a slight misalignment in the ultrasound focal zone proximity to the fluorescent pellet led to a total loss of the modulated fluorescence signal demonstrating that the method should provide a very high spatial resolution (\sim mm).

Beyond the quadrature detection of ultrasound-modulated photons demonstrated here, we plan to perform acousto-optic imaging with this detection approach. The laser and ultrasound focal zone will be raster-scanned across an optically scattering object and the amplitude of the ultrasound-modulated photons measured for each scan position to provide an image. For a homogeneous object we expect constant amplitude, whereas scanning across a more optically attenuating inhomogeneity we expect a decrease in amplitude. Alternatively, in fluorescence imaging mode scanning across a fluorescent inhomogeneity we expect an increase in amplitude due to the detection of ultrasound-modulated fluorescence photons. Since only photons within the small ultrasound focal zone are modulated and contribute to the acousto-optic images we expect much higher image spatial resolution than achievable from optical imaging which employs all detected photons.

CONCLUSIONS

This work has presented the novel quadrature detection of ultrasound-modulated photons with a gain-modulated, image-intensified CCD camera. Furthermore, the detection with this novel approach of ultrasound-modulated fluorescence, an incoherent process, offers the opportunity for acousto-optic molecular imaging employing fluorescence-based probes. Future work will involve a scanning configuration to perform acousto-optic imaging.

ACKNOWLEDGEMENTS

The authors gratefully acknowledge a DOD Army PCRP Idea Development award (W81XWH-07-1-0125) for funding this work, support from GE Healthcare, and useful discussions with Dr. Robert Mattrey (UCSD) regarding ultrasound.

REFERENCES

- [1] Weissleder R, Ntziachristos V. Shedding light onto live molecular targets. *Nat Med* 2003; 9: 123-8.
- [2] Rice B, Cable M, Nelson M. *In Vivo* Imaging of Light-emitting Probes. *J Biomed Opt* 2001; 6(4): 432-40.
- [3] Intes X, Djaziri S, Ichalalene Z, *et al.* Time-domain optical mammography SoftScan: Initial results. *Acad Radiol* 2005; 12(8): 934-47.
- [4] Oraevsky A. Detection, diagnostics and image-guided therapy of cancer using laser optoacoustic imaging system and gold nanoparticles. *IEEE* 2004; 250-51.
- [5] Wang L. Ultrasound-mediated biophotonic imaging: A review of acousto-optical tomography and photo-acoustic tomography. *Dis Markers* 2003; 19: 123-38.
- [6] Wang L, Jacques S, Zhao X. Continuous-wave ultrasonic modulation of scattered laser light to image objects in turbid media. *Opt Lett* 1995; 20(6): 629-31.
- [7] Li J, Ku G, Wang L. Ultrasound-modulated optical tomography of biological tissue by use of contrast of laser speckles. *Appl Opt* 2002; 41(28): 6030-5.

- [8] Leveque S, Boccara A, Lebec M, Saint-Jalmes H. Ultrasonic tagging of photon paths in scattering media: parallel speckle modulation processing. *Opt Lett* 1999; 24(3): 181-3.
- [9] Wang L. Mechanisms of Ultrasonic modulation of multiply scattered coherent light: An analytical model. *Phys Rev Lett* 2001; 87(4): 043903.
- [10] Zemp R, Sakadzic S, Wang L. Stochastic explanation of speckle contrast detection in ultrasound-modulated optical tomography. *Phys Rev E* 2006; 73: 061920.
- [11] Krishnan K, Formitchov P, Lomnes S, Kollegal M, Jansen F. A theory for the ultrasonic modulation of incoherent light in turbid medium. *SPIE* 2005; 6009: 147-58.
- [12] Hall D, Han S. Preliminary Results from a multi-wavelength time domain optical molecular imaging system. *SPIE* 2007; 6430: 64300T.

Received: August 8, 2008

Revised: September 8, 2008

Accepted: September 9, 2008

© Hall *et al.*; Licensee *Bentham Open*.

This is an open access article licensed under the terms of the Creative Commons Attribution Non-Commercial License (<http://creativecommons.org/licenses/by-nc/3.0/>) which permits unrestricted, non-commercial use, distribution and reproduction in any medium, provided the work is properly cited.

Detection of ultrasound-modulated photons and enhancement with ultrasound microbubbles

David J. Hall^{*1}, Mark J. Hsu², Sadik Esener², and Robert F. Mattrey¹
Departments of Radiology¹ and Electrical and Computer Engineering²

University of California, San Diego, 3855 Health Sciences Dr., La Jolla, CA USA 92093-0819

ABSTRACT

In vivo acousto-optic imaging promises to provide optical contrast at superior ultrasound spatial resolution. The main challenge is to detect ultrasound-modulated photons in the overwhelming presence of un-modulated photons. We have demonstrated in vitro detection of ultrasound-modulated photons with a variety of detection methods. Furthermore, we have detected ultrasound-modulated fluorescence offering potential for acousto-optic molecular imaging. Moreover, we have demonstrated the use of ultrasound microbubbles to significantly enhance the acousto-optic signal at the ultrasound frequency with the additional generation of higher order harmonic frequencies. Here the results from our various detection methods, ultrasound-modulated fluorescence, and enhancement with microbubbles are presented.

Keywords: acousto-optic, ultrasound-modulated photons, fluorescence, microbubbles

1. BACKGROUND

In vivo optical imaging is limited by the high optical scattering of tissue which limits the spatial resolution to centimeters for applications such as optical breast imaging[1]. Researchers are combining optics and ultrasound to provide optical images at superior ultrasound spatial resolution. A popular approach is opto-acoustic imaging which provides optical attenuation images at ultrasound resolution and is described elsewhere[2]. Alternatively, acousto-optic imaging involves the modulation of photons at the ultrasound frequency when they propagate through a small ultrasound focal zone[3]. Images generated from only these ultrasound-modulated photons, as opposed to all detected photons, will have the improved spatial resolution of the ultrasound focal zone. The main challenge is the detection and discrimination of ultrasound-modulated photons in the overwhelming presence of un-modulated photons not passing through the ultrasound focal zone. Here we present our detection of ultrasound-modulated photons with a variety of photo-detectors, detection of ultrasound-modulated fluorescence, and dramatic signal enhancement using ultrasound microbubbles.

2. METHODS & RESULTS

2.1 Detection of ultrasound-modulated photons with a silicon photo-detector

Coherent Photons

A 65 mm wide tank containing water and Intralipid for optical scattering was illuminated using a laser diode (5 mW at 650 nm, coherence length $\sim 5M$). Light was detected in transmission mode with a silicon photo-detector (PDA36A, ThorLabs), amplified (10dB built-in gain), filtered (Stanford Research Systems, SR560) to remove DC and low frequency noise (<10 KHz) and recorded on a digital scope (Tektronix, TDS 2012B). A function generator (Stanford Research Systems, DS345) and RF Amplifier (ENI, 240L) delivered to a single-element US transducer (Panametrics, V303, 3cm focal length) a 1 MHz sine wave (20 cycles at 50Vpp) every 50 μ s (2% duty cycle). The transducer was submerged in water and the light was passed through the US focal zone (Fig. 1a). The local US effect on water was sufficient to modulate the optical properties that were detected in the optical signal and displayed on the scope (Fig. 1b).

* djhall@ucsd.edu; phone 1 858 822-0893; fax 1 858 822-0950

A Fourier transform of this signal (Fig. 1c) shows a peak at 1 MHz (the US frequency) where the amplitude is proportional to the magnitude of the AO effect. When, the measurement was repeated without US there was no modulation detected.

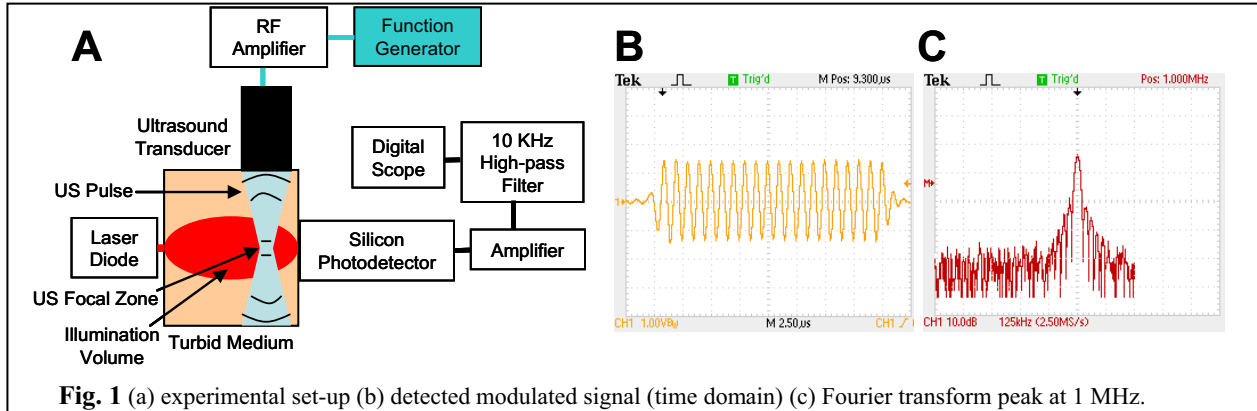

Incoherent Photons

Most previous AO research has used coherent photons with US modulation of photon path-lengths that affect phase that are detected as an interference “speckle” pattern [3]. The necessity for photon to remain coherent throughout their path in tissues that can easily reach six times the tissue thickness [4], requires lasers with long coherence length restricting the choice of available lasers. We used the experimental setup shown in Fig 1a but replaced the coherent light source with an incoherent light source (100 W Halogen Lamp, Schott KL1500) (Fig 2a). Fig 2b shows the detected modulation of the optical signal at the US frequency of 1 MHz. One other group [5] has also reported on the modulation of incoherent photons which relies upon modulation of the local optical attenuation coefficient that will affect all photons be they coherent or incoherent.

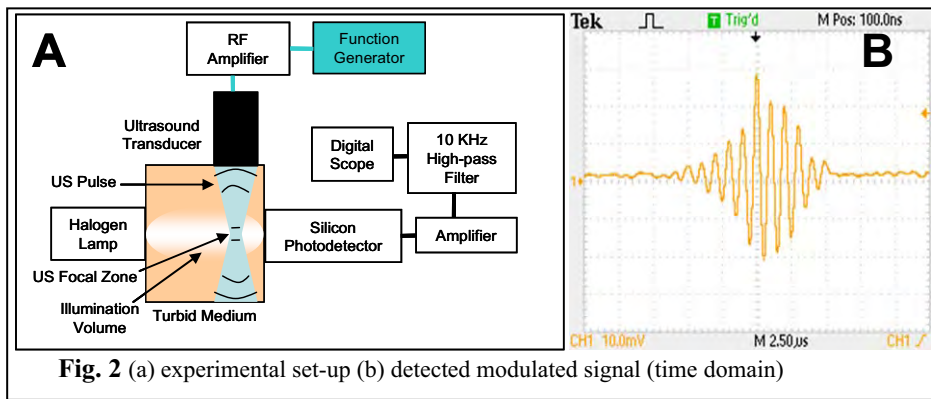

Enhancement with Ultrasound Microbubbles

A novel idea presented here is the use of microbubbles to increase photon modulation to improve AO detection. The modulation of microbubbles by ultrasound is expected to dramatically increase the photon modulation due to large oscillatory volume changes of the microbubbles leading to large modulation of the local optical properties. To test this hypothesis we modified the experimental set-up shown in figure 1 by submerging a quartz cuvette (12.5x12.5x68mm) in the US focal zone of a 2.25 MHz transducer driven at 1.5 MHz. We also prepared Definity (FDA approved US contrast agent, Bristol-Myers Squibb Medical Imaging) per manufacturer’s instruction and then filled a 1-mL syringe and allowed the microbubbles to settle. By obtaining samples from the syringe at different depths we obtained three suspensions of small (least buoyant), medium, and large (most buoyant) microbubbles. Each microbubble suspension was placed in the cuvette individually and the corresponding AO signal measured. Between different suspensions the cuvette was washed thoroughly with pure saline for which we also measured the AO signal as a control. Fig. 3a shows

the detected AO modulation in the frequency domain where it can be seen that there is an increase in the photon modulation at the fundamental frequency (1.5 MHz) for all microbubble suspensions compared to the saline. Furthermore, higher order harmonics are observed at 3 and 4.5MHz for the medium and large microbubbles. Fig. 3b quantifies the significant dB gain of the modulated photons beyond the saline control by the addition of microbubbles.

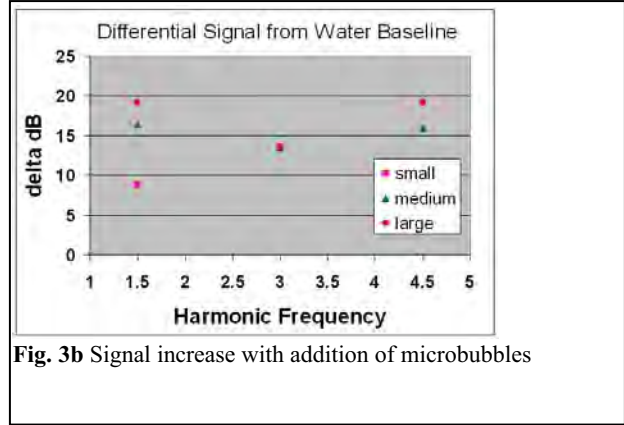
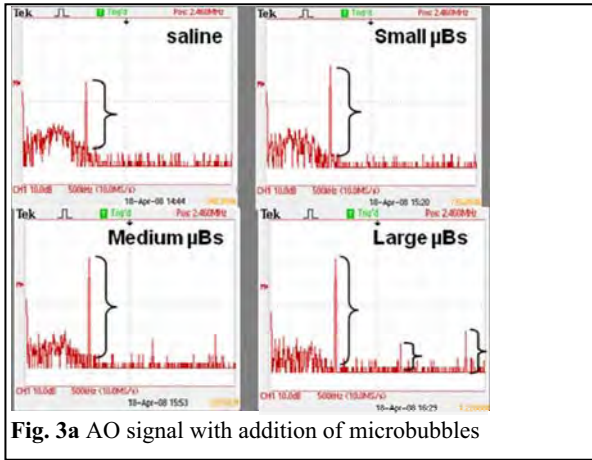

2.2 Quadrature Detection of ultrasound-modulated photons with a gain-modulated image-intensifier

The ability to measure ultrasound-modulated incoherent photons offers the opportunity to measure ultrasound-modulated fluorescence with future potential for AO molecular imaging with fluorescence-based probes. To our knowledge only two other groups have detected US-modulated fluorescence [5, 6]. We also attempted to detect ultrasound-modulated fluorescence with our silicon photo-detector but found the fluorescence signal too weak to detect. However, we also have a highly sensitive image-intensified (*Picostar*, LaVision, Germany) EMCCD camera (Andor, CA) and detected ultrasound-modulated fluorescence using a novel gain-modulated quadrature approach which is reported in more detail elsewhere [7]. Basically, the optical detector is gain-modulated at the US frequency and the photon intensity is measured as the phase shift, $\Delta\Phi$, between the US and detector-gain driving signals is varied. The ultrasound-induced photon modulation can then be recovered from just four phase shift measurements (quadrature). Moreover, by intentionally adjusting the phase-shift such that maximum and minimum photon intensity is measured at $\Delta\Phi=0^\circ$ and 180° respectively, the photon modulation is simply $I\Delta\Phi_0^\circ - I\Delta\Phi_{180^\circ}$. For brevity, Fig. 4a shows the detection of US-modulated photons and Fig. 4b shows the detection of ultrasound-modulated fluorescence from a Qdot800 (Invitrogen, CA) fluorescent pellet. As expected, the fluorescence signal is much weaker but is nevertheless detectable.

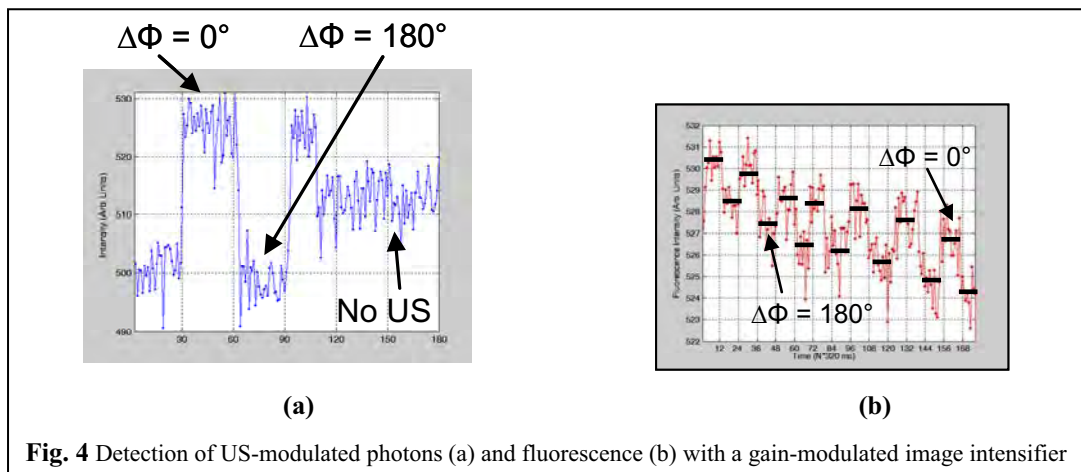

2.3 Detection of ultrasound-modulated photons with a Photomultiplier tube

Detection of AO modulated photons has traditionally been done with photomultiplier tubes due to their good quantum efficiencies and high gains[3]. We used a similar setup shown in Fig. 1a and replaced the silicon photo-detector with a Hamamatsu HC-125 Analog PMT with 8MHz bandwidth. Here, we used a 532nm, 5mW laser for better detector sensitivity and placed an aperture in front of the PMT to reduce the total photon flux to prevent detector saturation. A clear ultrasound-modulated light signal was measured and is shown in the time domain (Fig. 5a) and frequency domain (Fig. 5b).

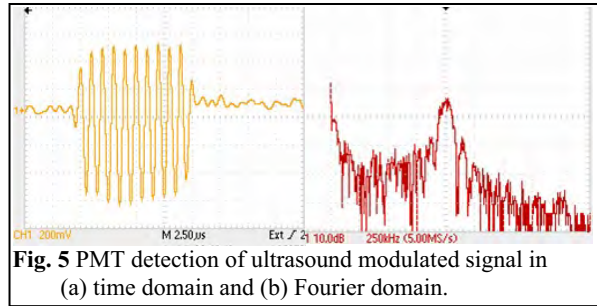

Real-time AO imaging will inevitably require photo-detector arrays to detect larger numbers of ultrasound-modulated photons. Large arrays of PMTs, however, are not practical due their inability to be cost-effectively scaled as well as their bulky and fragile nature. In the final section, we present preliminary results demonstrating feasibility of AO imaging with a CMOS SPAD capable of being scaled towards megapixel arrays for a fraction of the cost of a single PMT detector.

2.4 Detection of ultrasound-modulated photons with a Single Photon Avalanche Detector (SPAD)

To demonstrate the feasibility of using our SPAD detector, described in detail elsewhere [8], we used the experimental setup in Fig. 1a and replaced the silicon photo-detector, amplifier, high-pass filter, and scope with our 7-µm SPAD, counter and computer to display photon counts over time. Again, we used a 5mW, 532nm laser given this SPAD is more sensitive at these shorter wavelengths. Despite the SPAD's small detection area (7-µm) we were able to clearly detect the modulated optical signal in the SPAD's time-of-arrival count histogram (Fig. 6a). A Fourier transform of this signal (Fig. 6b) shows the expected peak at 1 MHz (the US frequency). In principle, the larger active area of a 2D array should capture many more photons increasing SNR.

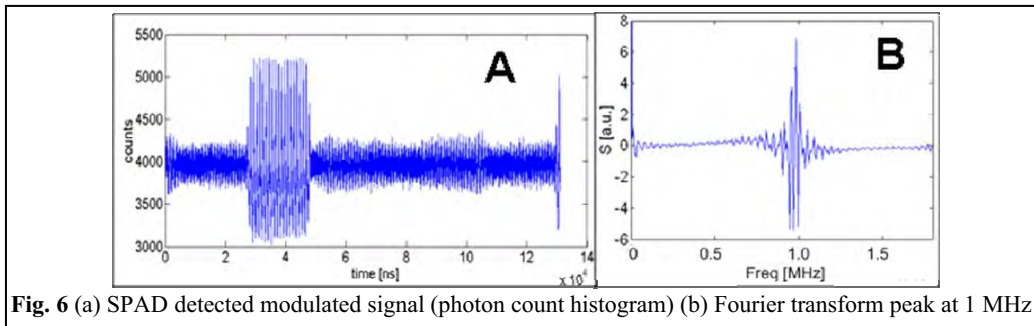

3. CONCLUSION

These preliminary results demonstrate our ability to measure US-modulated coherent, incoherent, and fluorescence light using a variety of photo-detectors. We believe that the combination of the high photon count rate, sensitivity, and large sampling area that will be possible with SPAD arrays will provide sufficient signal for in vivo AO detection of ultrasound-modulated photons with clinically-viable acquisition times. Equally important, we showed that microbubbles dramatically enhance AO photon modulation at both the fundamental and higher order harmonic frequencies as is known to occur with US imaging[9]. This signal enhancement should greatly improve detection of ultrasound-modulated photons especially for challenging, highly scattering, in vivo environments. Furthermore, the specific harmonic signature of microbubbles will help identify and discriminate them from ultrasound-modulation of native tissue optical properties leading to high specificity with targeted microbubbles. Moreover, ultrasound-modulated fluorescence from fluorophores in the vicinity (or attached) to microbubbles will also be encoded with their harmonic signature thus differentiating them from fluorophores not in the vicinity of microbubbles. In future work we plan to generate AO images and explore fluorophore-labelled microbubbles.

4. ACKNOWLEDGEMENTS

The authors gratefully acknowledge the DOD: W81XWH-07-1-0125 and NCI: U54-CA 119335 and R21-EB005360 for funding this research.

REFERENCES

- [1] Intes, X., Djeziri, S., Ichalalene, Z., Mincu, N., Wang, Y., St-Jean, P., Lesage, F., Hall, D., Boas, D., Polyzos, M., Fleiszer, D., and Mesurolle, B., "Time-domain optical mammography SoftScan: Initial results," *Academic Radiology* 12, 1355-1355 (2005).
- [2] Oraevsky, A., "Detection, diagnostics and image-guided therapy of cancer using laser optoacoustic imaging system and gold nanoparticles," *IEEE* 0780386760, 250- 251 (2004).
- [3] Wang, L., "Ultrasound-mediated biophotonic imaging: a review of acousto-optical tomography and photoacoustic tomography," *Dis Markers* 19, 123-138 (2003).
- [4] Van der Zee, P., Cope, M., Arridge, S. R., Essenpreis, M., Potter, L. A., Edwards, A. D., Wyatt, J. S., McCormick, D. C., Roth, S. C., Reynolds, E. O., and Delpy, D. T., "Experimentally measured optical pathlengths for the adult head, calf, and forearm and the head of the newborn infant as a function of interoptode spacing," *Adv Exp Med Bio* 316, 143-153 (1992).
- [5] Krishnan, K., Fomitchov, B., Lomnes, S., Kollegal, M., and Jansen, F., "A theory for the ultrasonic modulation of incoherent light in turbid medium," *SPIE* 6009, 60090V1-V12 (2005).
- [6] Kobayashi, M., Mizumoto, T., Shibuya, Y., and Enomoto, M., "Fluorescence tomography in turbid media based on acousto-optic modulation imaging," *Appl. Phys. Letters* 89, 181102:1-3 (2006).
- [7] Hall, D. J., Sunar, U., and Farshchi-Heydari, S., "Quadrature Detection of Ultrasound-Modulated Photons with a Gain-Modulated, Image-Intensified, CCD Camera," *Open Optics* 2, 75-78 (2008).
- [8] Finkelstein, H., Hsu, M. J., and Esener, S. C., "STI-bounded single-photon avalanche diode in a deep-submicrometer CMOS technology," *IEEE Electron Device Letters* 27, 887-889 (2006).
- [9] De Jong, N., Bouakaz, A., and Frinking, P., "Basic Acoustic Properties of Microbubbles," *Echography* 19, 229-240 (2002).

FEASIBILITY OF DUAL OPTICS-ULTRASOUND IMAGING AND CONTRAST MEDIA FOR THE DETECTION AND CHARACTERIZATION OF PROSTATE CANCER

David Hall, Mark Hsu, Andrew Goodwin, Mohammad Eghtedari, Sadik Esener, and Robert Mattrey

University of California, San Diego

Background and Objectives: This research project focuses on prostate cancer, a devastating socioeconomic disease, whose detection is plagued with inadequate sensitivity and specificity. Hypoxia is the hallmark of malignancy because aggressive cancers outgrow their blood supply. Optical imaging is emerging as a physiologic tool capable of quantifying hypoxia but only at centimeter spatial resolution, which is unacceptable for prostate cancer imaging. We ultimately aim to build an instrument that combines Optics and UltraSound (OPUS) to quantify hypoxia via optical imaging but with the improved spatial resolution of ultrasound imaging. Specifically, the acousto-optic effect will be used to only modulate light (at the ultrasound frequency), which propagates through a small ultrasound focal zone. Optical images generated from only ultrasound-modulated light will thus have the improved spatial resolution of the ultrasound focal zone. The main difficulty is the detection and discrimination of ultrasound-modulated light from the overwhelming presence of non-modulated light not passing through the ultrasound focal zone. This Department of Defense Idea Development Award is concerned with the development of a novel detection idea based on quadrature measurements with a gain-modulated image intensified CCD (charged coupled device) camera. Furthermore, we propose the novel idea of using microbubble-based contrast agents to significantly increase the light modulation and, moreover, the use of fluorescent microbubbles to provide additional enhancement.

Brief Description of Methodologies: In addition to standard photomultiplier tubes, we explored the novel quadrature detection of ultrasound-modulated photons with a gain-modulated image intensified CCD camera. Here, a continuous wave laser source is employed, and the gain of the optical detector is modulated at the same frequency as the ultrasound. The CCD image is acquired at four phase shifts between optical detector modulation and ultrasound modulation from which the amplitude of the ultrasound-modulated photons can be extracted. Through collaboration with the Electrical and Computer Engineering Department at the University of California, San Diego, we also explored the use of a novel single photon avalanche diode (SPAD) to detect ultrasound-modulated photons. Systems were extended to measuring ultrasound-modulated fluorescence with fluorescence filters. Microbubbles significantly increased the amplitude of ultrasound-modulated photons.

Results: Novel quadrature detection of ultrasound-modulated photons and fluorescence photons with a gain-modulated image-intensified CCD. Significant increase of ultrasound-modulated photons with microbubbles and generation of specific higher harmonics. Detection of ultrasound-modulated photons with novel SPAD detector. Development of acousto-optic light scattering system and characterization of ultrasound-induced oscillation of individual microbubbles in real-time. Observation of microbubble collapse, implosion at higher ultrasound pressures, and ultrasound-modulation of fluorescent microbubbles.

Conclusions: This project has demonstrated the detection of ultrasound-modulated photons with novel optical detection schemes. The modulation was improved with microbubbles and extended to fluorescent microbubbles.

Impact Statement: Ultimately, acousto-optic imaging could be used to diagnose prostate cancer in vivo based on optical contrast of endogenous hypoxia and/or cancer-targeted fluorescent microbubbles at ultrasound spatial resolution.

This work was supported by the U.S. Army Medical Research and Materiel Command under W81XWH-07-1-0125.