



AFRL-RX-WP-TP-2011-4348

**EDDY CURRENT BENCHMARKING EXPERIMENTS FOR
MODEL VALIDATION AT AFRL (POSTPRINT)**

Jeremy.S. Knopp and Mark P. Blodgett

Nondestructive Evaluation Branch

Metals, Ceramics & Nondestructive Evaluation Division

Ryan D. Mooers

Iowa State University

Center for Nondestructive Evaluation

OCTOBER 2011

Approved for public release; distribution unlimited.

See additional restrictions described on inside pages

STINFO COPY

**AIR FORCE RESEARCH LABORATORY
MATERIALS AND MANUFACTURING DIRECTORATE
WRIGHT-PATTERSON AIR FORCE BASE, OH 45433-7750
AIR FORCE MATERIEL COMMAND
UNITED STATES AIR FORCE**

REPORT DOCUMENTATION PAGE				<i>Form Approved</i> OMB No. 0704-0188	
<p>The public reporting burden for this collection of information is estimated to average 1 hour per response, including the time for reviewing instructions, searching existing data sources, gathering and maintaining the data needed, and completing and reviewing the collection of information. Send comments regarding this burden estimate or any other aspect of this collection of information, including suggestions for reducing this burden, to Department of Defense, Washington Headquarters Services, Directorate for Information Operations and Reports (0704-0188), 1215 Jefferson Davis Highway, Suite 1204, Arlington, VA 22202-4302. Respondents should be aware that notwithstanding any other provision of law, no person shall be subject to any penalty for failing to comply with a collection of information if it does not display a currently valid OMB control number. PLEASE DO NOT RETURN YOUR FORM TO THE ABOVE ADDRESS.</p>					
1. REPORT DATE (DD-MM-YY) October 2011		2. REPORT TYPE Technical Paper		3. DATES COVERED (From - To) 25 June 2009 – 4 December 2009	
4. TITLE AND SUBTITLE EDDY CURRENT BENCHMARKING EXPERIMENTS FOR MODEL VALIDATION AT AFRL (POSTPRINT)				5a. CONTRACT NUMBER In-house	
				5b. GRANT NUMBER	
				5c. PROGRAM ELEMENT NUMBER 62102F	
6. AUTHOR(S) Jeremy.S. Knopp and Mark P. Blodgett (AFRL/RXLP) Ryan D. Mooers (Iowa State University/Center for Nondestructive Evaluation)				5d. PROJECT NUMBER 4349	
				5e. TASK NUMBER 40	
				5f. WORK UNIT NUMBER LP110100	
7. PERFORMING ORGANIZATION NAME(S) AND ADDRESS(ES) Nondestructive Evaluation Branch (AFRL/RXLP) Metals, Ceramics & Nondestructive Evaluation Division Materials and Manufacturing Directorate Wright-Patterson Air Force Base, OH 45433-7750 Air Force Materiel Command, United States Air Force				Iowa State University Center for Nondestructive Evaluation 1915 Scholl Road 111 ASC II Ames, Iowa 500-11-3041	
9. SPONSORING/MONITORING AGENCY NAME(S) AND ADDRESS(ES) Air Force Research Laboratory Materials and Manufacturing Directorate Wright-Patterson Air Force Base, OH 45433-7750 Air Force Materiel Command United States Air Force				8. PERFORMING ORGANIZATION REPORT NUMBER AFRL-RX-WP-TP-2011-4348	
				10. SPONSORING/MONITORING AGENCY ACRONYM(S) AFRL/RXLP	
				11. SPONSORING/MONITORING AGENCY REPORT NUMBER(S) AFRL-RX-WP-TP-2011-4348	
12. DISTRIBUTION/AVAILABILITY STATEMENT Approved for public release; distribution unlimited.					
13. SUPPLEMENTARY NOTES The U.S. Government is joint author of the work and has the right to use, modify, reproduce, release, perform, display, or disclose the work. PA Case Number and clearance date: 88ABW-2010-0013, 4 Jan 2010. Published in Applied Computational Electromagnetic Society; Tampere, Finland; April 2010. This document contains color.					
14. ABSTRACT To support an effort to estimate characteristics of surface-connected damage (i.e., cracks) in aerospace and propulsion structures, a computer-controlled scanning capability that acquires experimental eddy current data was developed based on an Agilent 4294A Impedance Analyzer. This instrument is being used to assess performance of different computational electromagnetic codes in terms of determining how well they predict the complex response from simulated flaws in conducting plates. The particular benchmark problem of interest in this paper measures the real and imaginary impedance due to Electrical-Discharge Machined (EDM) notches in aluminum plates that are approximately 13 mm thick. These EDM notches are 5mm deep and have the same surface length and width. A range of notches have been generated for this study, which includes vertically oriented notches and angled notches of 10, 20 and 30 degrees relative to the surface normal.					
15. SUBJECT TERMS flaw characterization, complex impedance, eddy current, volume integral method.					
16. SECURITY CLASSIFICATION OF:			17. LIMITATION OF ABSTRACT: SAR	18. NUMBER OF PAGES 8	19a. NAME OF RESPONSIBLE PERSON (Monitor) Mark Blodgett
a. REPORT Unclassified	b. ABSTRACT Unclassified	c. THIS PAGE Unclassified			

Eddy Current Benchmarking Experiments for Model Validation at AFRL

Ryan D. Mooers², Jeremy S. Knopp¹, Mark P. Blodgett¹

¹ Air Force Research Laboratory (AFRL/RXLP), Wright-Patterson AFB, OH 45433, USA
mark.blodgett@wpafb.af.mil, jeremy.knopp@wpafb.af.mil,

² Iowa State University/Center for Nondestructive Evaluation
rymooers32@gmail.com

Abstract: To support an effort to estimate characteristics of surface-connected damage (i.e., cracks) in aerospace and propulsion structures, a computer-controlled scanning capability that acquires experimental eddy current data was developed based on an Agilent 4294A Impedance Analyzer. This instrument is being used to assess performance of different computational electromagnetic codes in terms of determining how well they predict the complex response from simulated flaws in conducting plates. The particular benchmark problem of interest in this paper measures the real and imaginary impedance due to Electrical-Discharge Machined (EDM) notches in aluminum plates that are approximately 13 mm thick. These EDM notches are 5mm deep and have the same surface length and width. A range of notches have been generated for this study, which includes vertically oriented notches and angled notches of 10, 20 and 30 degrees relative to the surface normal.

Keywords: flaw characterization, complex impedance, eddy current, volume integral method.

1. Introduction

In the last few decades, several eddy current simulation tools have been developed both commercially and as research grade software packages. These are based on several different numerical methods such as the finite difference time domain method, finite element, boundary element, volume integral, and mesh less methods. This paper focuses on a previous experiment conducted by Burke [1]. This is a simple problem that can be used to determine the accuracy and efficiency of different numerical methods. The two codes used in this paper are VIC 3D [2], a volume integral code, and EC SIM [3-4], which uses the boundary element method for solution. Future experiments will be provided to the wider community for assessment of simulation codes based on different numerical methods.

2. Background / Benchmark Experiment

This experiment uses a large circular air cored probe, scanned over the length of a large rectangular notch in a plate of aluminum. The overall experimental setup can be seen in Figure 1, with the dimensions labeled and given in Table 1. The proportions of the plate, the probe, and the test parameters have been chosen such that the outer radius of the probe and the length of the notch are on the same order. For each scan position over the plate, the change in impedance (ΔZ) is measured. Three plates were used for this experiment, each of a different alloy chemistry and conductivity, which differs from the alloy used in the original Burke study. The three alloys used were 6061 T6, 7075 T6 and 2024 T3. Each square plate has notches placed in the center. Figure 2 shows the testing apparatus with the probe and plate in place. This experiment was conducted according to the procedure published by Harrison et al [5]. Other methods that use voltage measuring instruments have been proposed, but these all rely on a transfer function approach between the measured impedance and voltage output [6]. The concern is that error in the model can essentially be absorbed by the transfer function and therefore is not suitable for model validation. It should be noted however, that once proper benchmark experiments are conducted, such transfer functions have great value in making field instruments compatible with simulations and model-based inverse methods. Table 1 lists the conductivity values used for this experiment.

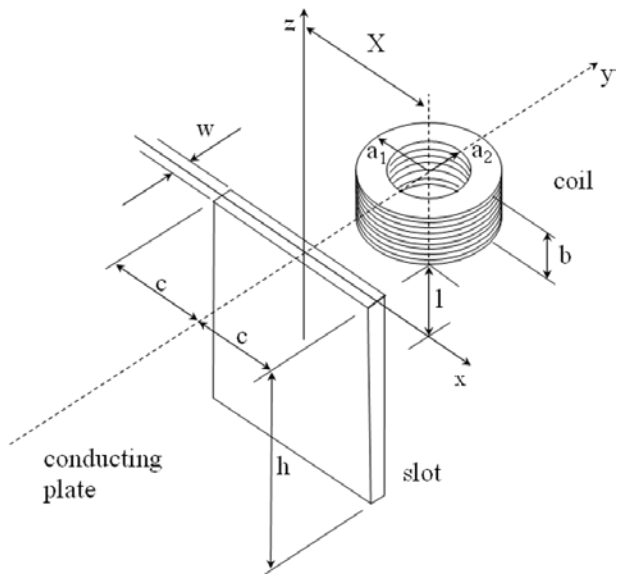

	<u>Coil</u>	
Inner radius		6.15 mm
Outer radius		12.4 mm
Length		6.15 mm
Number of turns		3790
Lift-off		0.88 mm
	<u>Test specimen</u>	
Conductivity		3.06 S/m
Plate thickness		12.22 mm
	<u>Defect</u>	
Length		12.60 mm
Depth		5.00 mm
Width		0.28 mm
	<u>Other</u>	
Frequency		900 Hz

Figure 1. Experimental setup

Table 1. Experimental parameters

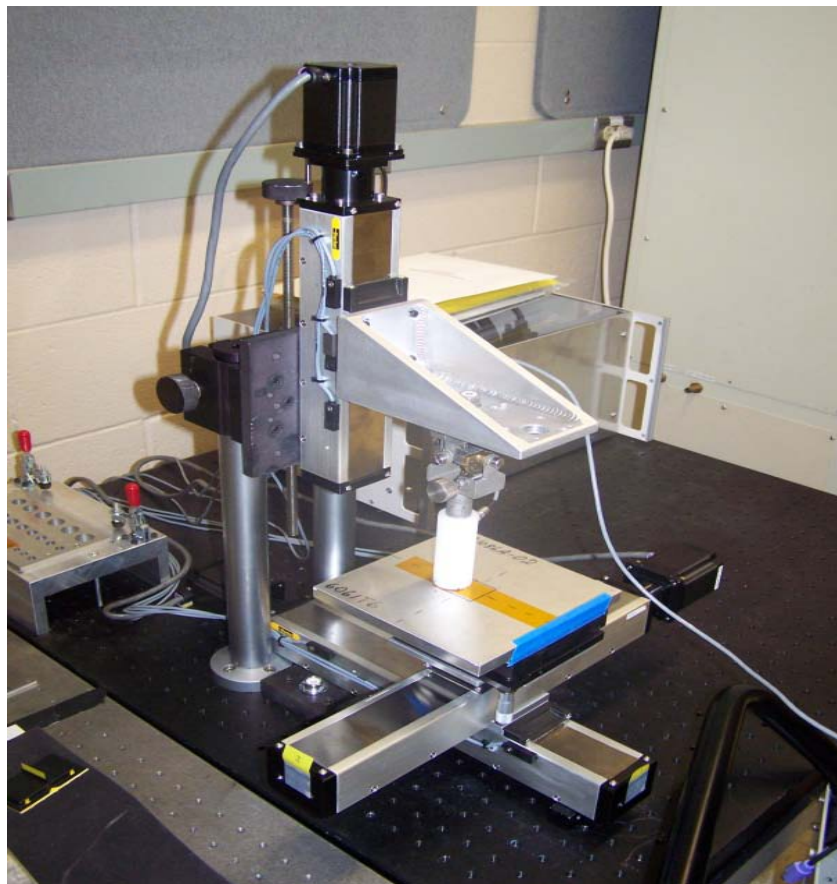

Figure 2. Testing Apparatus with probe and plate in position

3. Experimental Procedure

Preliminary measurements are needed for later post-processing of the data. This includes the DC values of resistance and inductance, as well as multiple scans to determine if repeatability is affected by temperature variations or other experimental factors. The DC value for probe resistance was found using a 4 point analysis. The DC value for inductance was found by running the probe over a range of frequencies and interpolating back to the DC value. This method also verified the value for the DC resistance. For each of these scans a thin plate of aluminum was leveled using a digital protractor.

A series of air scans were run to check for the consistency of the probe. The error between identical air scans taken at different times was about 0.3%. The test plate was then placed on the test stand, and leveled using the same digital protractor as with the previous test plate. The probe was then positioned in a defect free area, with the center of the probe at least a probe radius from the edge of the notch. The probe was then scanned parallel to the notch, using the same scan length to be used with the actual notch. The purpose of this was to measure subtle variations in the plate conductivity and other factors that may impact the experiment. Finally, the scans over the notch were performed. These were run such that the probe field did not interact with the notch at each end of the scan.

The experiment conducted as described yielded reproducible measurements. The data bracketing process consisted of taking two separate air scans before running a test, followed by anywhere from 2 to 4 unflawed scans, then a set of 5 to 6 notch scans; this was then repeated in reverse order to verify reproducibility.

4. Correction for Parasitic Capacitance and Other Non-ideal Coil Behavior

A final step needs to be taken after data collection. Here is where the previous measurements taken before the scans are used. This parallel network comes about from the deviation from the ideal values for a particular eddy current probe. The parallel network can be broken down into three main components; these being self-resistance and self-capacitance, along with the lead capacitance. This correction procedure begins with using the DC resistance and inductance values to find ideal admittance [5].

$$Y_o = 1/Z_o = 1/(R_o + j\omega L_o) \quad (1)$$

This value is subtracted from the air admittance value.

$$Y_A = 1/Z_A \quad (2)$$

By performing this subtraction, the admittance of the parallel network is obtained.

$$Y_p = Y_A - Y_o \quad (3)$$

The admittance of the probe over an unflawed region of the plate is achieved by subtracting the admittance of the unflawed region from the parallel network admittance.

$$Z_{CORR}^U = 1/(Y_U - Y_p) \quad (4)$$

To find the change in the corrected impedance, this value for the corrected unflawed impedance must be subtracted from the DC value.

$$\Delta Z_{CORR}^U = Z_{CORR}^U - Z_o \quad (5)$$

When a defect is seen in the region under the probe, the equation below gives the impedance change.

$$\Delta Z_{CORR}^D = 1/(Y_D - Y_p) - 1/(Y_U - Y_p) \quad (6)$$

5. Results

In this section the results from the experiments, with the corrections made, as well as the simulations from both EC SIM and VIC 3D will be presented for two of the plates. In looking at Figures 3a, 3c and 3e the results have a good agreement in shape and there are some slight discrepancies in the magnitude. The majority of this discrepancy is a shift in the experimental data, either up or down. The same general trends can be seen in Figures 3b, 3d, and 3f. Figure 3b shows a legend which is consistent for all the Figures in this section.

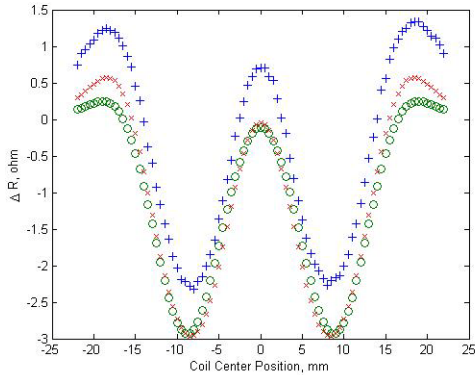

Figure 3a. Resistance for 6061 T6

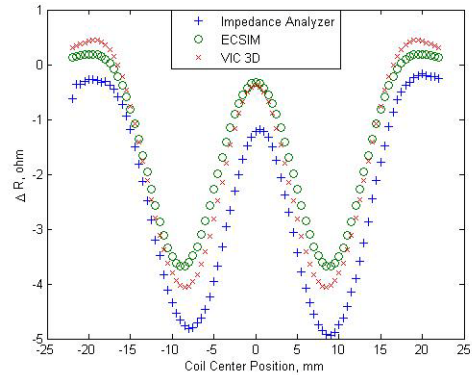

Figure 3b. Resistance for 7075 T6

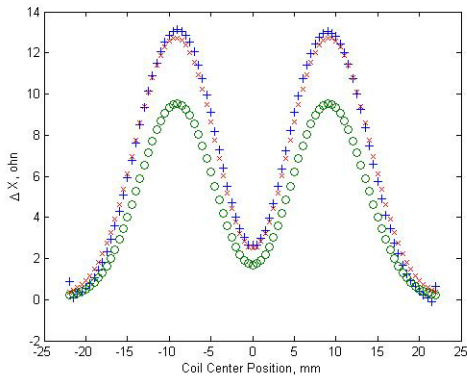

Figure 3c. Reactance for 6061 T6

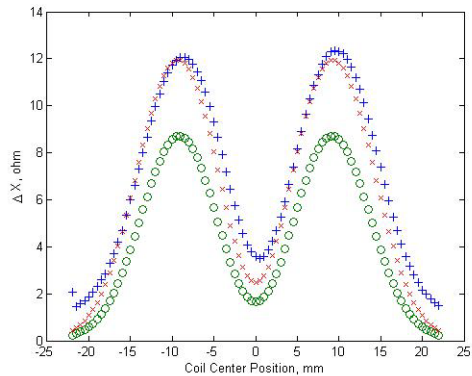

Figure 3d. Reactance for 7075 T6

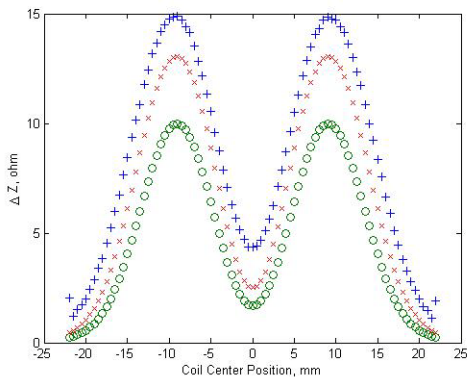

Figure 3e. Impedance for 6061 T6

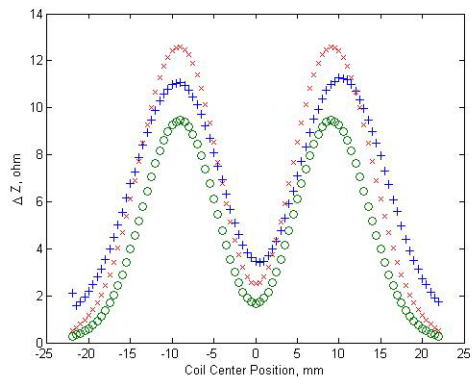

Figure 3f. Impedance for 7075 T6

6. Conclusion

As displayed in the graphs above, there is qualitative agreement in the shape of each of the curves. There is a discrepancy in the magnitude of the plots as well as an offset, in the experimental data. This can be seen best in Figure 3a and Figure 3b. One would expect the data after the correction to approach zero away from the notch, with the subtraction of the unflawed sections, but this is not the case. This could indicate that the probe interacted with the edge or the notch at ends of the scan. For the most part there is very good agreement in a few of the plots, in both magnitude and shape, such as Figure 3c and Figure 3d plate, but there are still slight discrepancies in the at the endpoints. In looking at Figures 3a, and more importantly 3c and 3e, it become clear that the error in the Figure 3e is due to the shift seen in Figure 3a.

In reviewing the results of the two simulation codes, some interesting trends were evident. In the resistance component shown in Figure 3a and Figure 3b, there is good correlation, both in shape and magnitude. This type of correlation does not appear in the other plots. In Figures 3c-f the two codes produce radically different results. In comparing the simulation codes to the experimental data it can be seen that in the majority of the plots, the results generated by VIC-3D are more in agreement with the experimental data.

One outcome of this investigation was an appreciation for the liftoff control necessary for this type of experiment. The original study made use of a spring-loaded mechanism to keep the probe at desired constant liftoff. This was not done for these experiments. In addition, the mechanism to remove any tilt form the probe, in either perpendicular or parallel direction to the scan, was rather cumbersome and inaccurate, which made accurate leveling of the probe somewhat difficult.

Acknowledgement

Funding was provided by the Air Force Research Laboratory, NDE Branch. The authors would like to thank Edward Klosterman, Richard Riebel and Tom Boehnlein for their valuable efforts in this research.

References

1. S.K. Burke, A benchmark problem for computation of DZ in eddy-current nondestructive evaluation (NDE), *J. Nondestruct. Eval.* 17, 1988, pp. 35-41.
2. R. Murphy, H. Sabbagh, A. Chan, and E. Sabbagh, A volume-integral code for electromagnetic nondestructive evaluation, in Proceedings of the 13th Annual *Review of Progress in Applied Computational Electromagnetics*, Monterey, CA, March, 1997.
3. J. Chao, N. Nakagawa, D. Raulerson, and J. Moulder, "A general boundary integral equation approach to eddy current crack modeling," *Rev. Prog. Quant. Nondestruct. Eval* Vol. 16, 1997, pp 279-285.
4. Norio Nakagawa and B.P.C. Rao, "A Study of Boundary Element Eddy Current Model Validation," *Rev. Prog. Quant. Nondestruct. Eval* Vol.24, 2005, pp 432-439.
5. D. Harrison, L. Jones, and S. Burke, Benchmark problems for defect size and shape determination in eddy current nondestructive evaluation, *J. Nondestruct. Eval.* 15, 1996, pp. 21-34.
6. J.S. Knopp, J.C. Aldrin, and P. Misra, Considerations in the validation and application of models for eddy current inspection of cracks around fastener holes, *J. Nondestruct. Eval.* 25, 2006, pp. 123-138.