

TECHNICAL REPORT
NATICK/TR-12/009



AD _____

REMOTE ENVIRONMENTAL MONITORING AND DIAGNOSTICS IN THE PERISHABLES SUPPLY CHAIN PHASE I

by
Jeffrey K. Brecht
Jean-Pierre Émond*
Maria Cecilia N. Nunes*
Charles A. Sims
Asli Obadasi
and
Ismail Uysal*

University of Florida
Gainesville, FL 32611-5500

***University of South Florida Polytechnic**
Lakeland, FL 33803

December 2011

Final Report
October 2008 – December 2010

Approved for public release; distribution is unlimited

Prepared for
U.S. Army Natick Soldier Research, Development and Engineering Center
Natick, Massachusetts 01760-5018

UNCLASSIFIED

DISCLAIMERS

The findings contained in this report are not to be construed as an official Department of the Army position unless so designated by other authorized documents.

Citation of trade names in this report does not constitute an official endorsement or approval of the use of such items.

DESTRUCTION NOTICE

For Classified Documents:

Follow the procedures in DoD 5200.22-M, Industrial Security Manual, Section II-19 or DoD 5200.1-R, Information Security Program Regulation, Chapter IX.

For Unclassified/Limited Distribution Documents:

Destroy by any method that prevents disclosure of contents or reconstruction of the document.

UNCLASSIFIED

REPORT DOCUMENTATION PAGE

Form Approved
OMB No. 0704-0188

Public reporting burden for this collection of information is estimated to average 1 hour per response, including the time for reviewing instructions, searching existing data sources, gathering and maintaining the data needed, and completing and reviewing this collection of information. Send comments regarding this burden estimate or any other aspect of this collection of information, including suggestions for reducing this burden to Department of Defense, Washington Headquarters Services, Directorate for Information Operations and Reports (0704-0188), 1215 Jefferson Davis Highway, Suite 1204, Arlington, VA 22202-4302. Respondents should be aware that notwithstanding any other provision of law, no person shall be subject to any penalty for failing to comply with a collection of information if it does not display a currently valid OMB control number.

PLEASE DO NOT RETURN YOUR FORM TO THE ABOVE ADDRESS.

1. REPORT DATE (DD-MM-YYYY) 12-12-2011		2. REPORT TYPE Final		3. DATES COVERED (From - To) October 2008 - December 2010	
4. TITLE AND SUBTITLE REMOTE ENVIRONMENTAL MONITORING AND DIAGNOSTICS IN THE PERISHABLES SUPPLY CHAIN - PHASE 1				5a. CONTRACT NUMBER W911QY-08-C-0136	
				5b. GRANT NUMBER	
				5c. PROGRAM ELEMENT NUMBER 63001	
6. AUTHOR(S) Jeffrey K. Brecht, Jean-Pierre Émond*, Maria Cecilia N. Nunes*, Charles A. Sims, Asli Obadasi, and Ismail Uysal*				5d. PROJECT NUMBER J52	
				5e. TASK NUMBER 30	
				5f. WORK UNIT NUMBER	
7. PERFORMING ORGANIZATION NAME(S) AND ADDRESS(ES) University of Florida 219 Grinter Hall Gainesville, FL 32611-5500				8. PERFORMING ORGANIZATION REPORT NUMBER	
9. SPONSORING / MONITORING AGENCY NAME(S) AND ADDRESS(ES) U.S. Army Natick Soldier Research, Development and Engineering Center ATTN: RDNS-CFG (J. Zanchi) Kansas Street, Natick, MA 01760-5018				10. SPONSOR/MONITOR'S ACRONYM(S) NSRDEC	
				11. SPONSOR/MONITOR'S REPORT NUMBER(S) NATICK/TR-12/009	
12. DISTRIBUTION / AVAILABILITY STATEMENT Approved for Public Release; distribution is unlimited					
13. SUPPLEMENTARY NOTES *University of South Florida Polytechnic (USFP), Lakeland, FL 33803, under a subcontract awarded to USFP by the University of Florida.					
14. ABSTRACT This report details the Phase 1 effort conducted by the University of Florida and the University of South Florida Polytechnic as part of a multi-year, multi-phase effort entitled "Remote Environmental Monitoring and Diagnostics in the Perishables Supply Chain" under a Broad Agency Announcement Contract awarded by the Natick Soldier Research, Development, and Engineering Center (NSRDEC) to the University of Florida. This work was conducted during the period October 2008 to December 2010 and involved the investigation and application of various technologies including wireless temperature sensors, remote monitoring using radio frequency identification (RFID), algorithms, and diagnostics, to demonstrate that ration shelf life can be automatically calculated in real time using web-based computer models. A prototype system including sensor equipped pallet level RFID tags, handheld readers, and computer shelf life models was identified, assessed and developed to determine the remaining shelf life of First Strike Rations based on ration time and temperature storage history.					
15. SUBJECT TERMS RATIONS MOBILE BATTERIES HIGH TEMPERATURES TEMPERATURE SENSORS SENSORS MONITORS PROTOTYPES COMPUTER MODELING COMMUNICATION RANGE STORAGE SHELF LIFE ALGORITHMS REMOTE MONITORING PERFORMANCE TESTS READERS TRACKING DIAGNOSTICS ENVIRONMENTAL TESTING WIRELESS ACCURACY SUPPLY CHAIN RELIABILITY(ELECTRONICS) LOGISTICS HAND HELD FOOD SAFETY RFID(FADIO FREQUENCY IDENTIFICATION) RFID TAGS PERISHABLE RANGE(DISTANCE) RADIOFREQUENCY IDENTIFICATION DEVICES					
16. SECURITY CLASSIFICATION OF:			17. LIMITATION OF ABSTRACT SAR	18. NUMBER OF PAGES 208	19a. NAME OF RESPONSIBLE PERSON Joseph Zanchi
a. REPORT U	b. ABSTRACT U	c. THIS PAGE U			19b. TELEPHONE NUMBER (include area code) (508)-233-4609

This page intentionally left blank

UNCLASSIFIED

Contents

List of Figures.....	vi
List of Tables.....	xiii
Executive Summary	xv
1 Objective 1 – Evaluation, Selection and Development of a Prototype, Sensor Enabled, Radio Frequency Identification (RFID) System for Temperature Tracking and Shelf Life Monitoring of First Strike Rations	1
1.1 Introduction.....	1
1.1.1 Objective 1 Team	2
1.2 Project Definition and Key Requirements	3
1.3 Evaluation and Selection of the Right Wireless Technology	4
1.3.1 Market Search	4
1.3.2 Environmental Testing Protocol – Procedure, Results and Discussion	6
1.3.3 Temperature Based Accuracy Testing.....	8
1.3.4 Environmental (Vibration & Temperature) Accuracy and Reliability Testing	20
1.3.5 Read Range Testing for Caen and Intellex Systems	31
1.3.6 Context Based Temperature Accuracy Metric	33
1.3.7 Shelf Life Estimation.....	34
1.4 Estimating the Inside Temperature of an FSR Pallet from the Recorded Environmental Temperature	35
1.5 General Information and System Overview for Caen System.....	42
1.5.1 Scan for Tags	44
1.5.2 Download Data.....	45
1.5.3 Run Shelf-Life Algorithm	46
1.5.4 Tag Admin	47
1.5.5 Configuration File	48
1.5.6 Error Conditions	49
1.5.7 Pricing.....	50
1.6 General Information and System Overview for Intellex System.....	51
1.6.1 Main Screen and Basic Operations	52
1.6.2 Downloading Data.....	54

1.6.3	Charting Temperature Data and Shelf Life Algorithm.....	56
1.6.4	Tag Configuration and Advanced Functionalities	58
1.6.5	Pricing.....	65
1.7	Conclusions - Validation and Final Recommendations	65
1.7.1	Validation	66
1.7.2	Final Recommendations.....	66
2	Objective 2a: Physical and Compositional Attributes of FSR Items During Storage at Different Temperatures.....	68
2.1	Introduction.....	68
2.2	Materials and Methods	68
2.2.1	FSR Items.....	68
2.2.2	Storage Conditions	71
2.2.3	Quality Evaluation	73
2.3	Results	77
2.3.1	Filled French Toast Pocket	77
2.3.2	Bacon Cheddar Pocket Sandwich	85
2.3.3	Wheat Snack Bread	92
2.3.4	Beef Snack, Sweet BBQ	99
2.3.5	Applesauce, CHO Enhanced (Zapplesauce).....	106
2.3.6	Italian Pocket Sandwich:	113
2.3.7	Tortillas.....	121
2.3.8	BBQ Beef Pocket Sandwich	127
2.3.9	Dessert Bar, Chocolate Banana Nut	135
2.4	General Conclusions.....	142
2.5	Objective 2 Literature Cited	144
3	Objective 2b: Sensory Attributes of FSR Items During Storage at Different Temperatures	145
3.1	Introduction.....	145
3.2	Materials and Methods	145
3.2.1	Reference Generation	146
3.2.2	Evaluation of Stored Samples	147
3.3	Results	149

3.3.1	80°F Storage	149
3.3.2	100°F Storage	154
3.3.3	120°F Storage	159
3.3.4	140°F Storage	164
3.4	Summary.....	170
4	Shelf Life Model Construction from Taste Panel Data	171
4.1	Introduction.....	171
4.2	Quality Index Determination From Taste Panel Results	172
5	Final Budget	179
5.1	Equipment Record.....	180
6	Overall Conclusions	181
	Appendix A - Environmental Testing Results	183
	Appendix B - System Specification Sheets	185

List of Figures

Figure 1. Environmental test chamber from the outside	6
Figure 2. Environmental test chamber with the door open	7
Figure 3. A close-up view of the inside of the environmental test chamber.....	7
Figure 4. Relationship between Celsius and Fahrenheit.....	10
Figure 5. Overall performance results for 10 Caen tags for 80% requirement range span testing.....	11
Figure 6. Individual Caen tag temperature logs for 80% requirement range span testing	12
Figure 7. Overall performance results for 10 Infratab tags for 80% requirement range span testing.....	12
Figure 8. Individual Infratab tag temperature logs for 80% requirement range span testing	13
Figure 9. Overall performance results for 10 Intellex tags for 80% requirement range span testing....	14
Figure 10. Individual Intellex tag temperature logs for 80% requirement range span testing	15
Figure 11. Averaged RFID tag – sensor output comparison for extended requirement limit testing	16
Figure 12. Averaged RFID tag – sensor output comparison for freezing temperature testing	18
Figure 13. Averaged RFID tag – sensor output comparison for two point swing testing	19
Figure 14. The power spectral density (PSD) of the vibration profile used for truck mode	22
Figure 15. Averaged RFID tag – sensor output comparison for 104°F to 5°F truck mode testing.....	23
Figure 16. Freezing temperatures for Infratab tags.....	23
Figure 17. The power spectral density (PSD) of the vibration profile used for rail mode	24
Figure 18. Averaged RFID tag – sensor output comparison for 104°F to 5°F rail mode testing.....	25
Figure 19. The power spectral density (PSD) of the vibration profile used for air mode.....	26
Figure 20. Averaged RFID tag – sensor output comparison for 104°F to 5°F air mode testing.....	26
Figure 21. Averaged RFID tag – sensor output comparison for 59°F to 118.4°F truck mode testing.....	28
Figure 22. The settings used for sine vibration testing.....	29
Figure 23. Averaged RFID tag – sensor output comparison for sine vibration testing @ 32°F	30
Figure 24. Tag orientations with respect to the handheld reader.....	31
Figure 25. A typical shelf life plot for an imaginary product.....	34
Figure 26. How the temperature inside the pallet at point labeled 20-alpha changes with the temperature outside the pallet	37
Figure 27. How the temperature inside the pallet at point labeled 36-prime changes with the temperature outside the pallet	37
Figure 28. A typical resistor-capacitor circuit to simulate the behavior of the pallet temperature in the presence of changing environmental temperature.....	38
Figure 29. Comparison of environmental temperature, measured pallet temperature and the estimated pallet temperature for point 20-alpha.....	40
Figure 30. Comparison of environmental temperature, measured pallet temperature and the estimated pallet temperature for point 36-prime	41
Figure 31. Psion Workabout Pro 2 Handheld Reader	42
Figure 32. A927Z Caen Temperature Tag	43
Figure 33. Scanning for Tags with Caen Reader.....	44

Figure 34. Downloading Tags with CAEN Reader.....	45
Figure 35. Running the Shelf-Life Algorithm with CAEN Reader.....	46
Figure 36. Tag Admin for CAEN Reader	47
Figure 37. Motorola MC9090 /w Intellex reader module.....	51
Figure 38. Intellex TMT 8500 temperature tag.....	51
Figure 39. Main screen of the UI for Intellex reader	52
Figure 40. Main screen of the UI for Intellex reader with specific tag selected.....	52
Figure 41. Status tab of Intellex reader displaying high temperature alarm.....	53
Figure 42. Data tab of Intellex reader	54
Figure 43. Temperature timestamp information on Intellex reader	54
Figure 44. Waypoints tab of Intellex reader	55
Figure 45. Info tab of Intellex reader	55
Figure 46. Options in the temperatures tab of Intellex reader	56
Figure 47. Example of shelf life graph of product with more than half of its shelf life still available	56
Figure 48. Examples of shelf life graphs displaying other outcomes.....	57
Figure 49. Export data option for the Intellex reader.....	57
Figure 50. Configuration tab of Intellex reader	58
Figure 51. Temps tab in configuration window of Intellex reader	59
Figure 52. Memory tab in configuration window of Intellex reader	59
Figure 53. Info tab in configuration window of Intellex reader.....	60
Figure 54. Waypoint tab of Intellex reader.....	60
Figure 55. Successful and Unsuccessful Attempts at Setting Waypoint on Intellex reader	61
Figure 56. Configuration of Tags with Intellex Reader	61
Figure 57. Successful and Unsuccessful Configurations of Tags with Intellex Reader	62
Figure 58. Stopping Tags from Logging with Intellex Reader	63
Figure 59. Resetting Tags with Intellex Reader.....	63
Figure 60. Properly Reset Tag in Intellex Reader	64
Figure 61. Settings Window of Intellex Reader	64
Figure 62. Physical and compositional evaluation (from left to right: color and texture analysis, sample preparation, and soluble solids content measurements).....	74
Figure 63. Changes in color attributes (L*, chroma, and hue) of Filled French Toast Pocket during a 52-week storage period at 40, 80, 100, 120, and 140°F.....	78
Figure 64. Changes in the appearance of Filled French Toast Pocket during a 52-week storage period at 40, 80, 100, 120, and 140°F.....	79
Figure 65. Changes in the texture of Filled French Toast Pocket during a 52-week storage period at 40, 80, 100, 120, and 140°F.....	80
Figure 66. Changes in pH, titratable acidity, and soluble solid contents of Filled French Toast Pocket during a 36-week storage period at 40, 80, 100, 120, and 140°F.....	81
Figure 67. Changes in moisture content and water activity of Filled French Toast Pocket during a 52-week storage period at 40, 80, 100, 120, and 140°F.....	82

Figure 68. Changes in sugar profiles of Filled French Toast Pocket during a 52-week storage period at 40, 80, 100, 120, and 140°F	83
Figure 69. Changes in maltodextrin content of Filled French Toast Pocket during a 52-week storage period at 40, 80, 100, 120, and 140°F.....	84
Figure 70. Changes in peroxide value of Filled French Toast Pocket during a 52-week storage period at 40, 80, 100, 120, and 140°F	84
Figure 71. Changes in the color attributes (L*, chroma, and hue) of Bacon Cheddar Pocket Sandwich during a 52-week storage period 40, 80, 100, 120, and 140°F.....	85
Figure 72. Changes in the appearance of Bacon Cheddar Pocket Sandwich during a 52-week storage period at 40, 80, 100, 120, and 140°F.....	86
Figure 73. Changes in the texture of Bacon Cheddar Pocket Sandwich during a 52-week storage period at 40, 80, 100, 120, and 140°F	86
Figure 74. Changes in pH, titratable acidity, and soluble solid contents of Bacon Cheddar Pocket Sandwich during a 36-week storage period at 40, 80, 100, 120, and 140°F	87
Figure 75. Changes in moisture content and water activity of Bacon Cheddar Pocket Sandwich during a 52-week storage period at 40, 80, 100, 120, and 140°F.....	88
Figure 76. Changes in the ascorbic acid content of Bacon Cheddar Pocket Sandwich during a 52-week storage period at 40, 80, 100, 120, and 140°F	89
Figure 77. Changes in the sugar profiles (sucrose, glucose, fructose, and total sugar) of Bacon Cheddar Pocket Sandwich during a 52-week storage period at 40, 80, 100, 120, and 140°F	90
Figure 78. Changes in the maltodextrin content of Bacon Cheddar Pocket Sandwich during a 52-week storage period at 40, 80, 100, 120, and 140°F	91
Figure 79. Changes in the peroxide value of the whole sandwich and in the meat only of Bacon Cheddar Pocket Sandwich stored for a 52-week storage period at 40, 80, 100, 120, and 140°F.....	91
Figure 80. Changes in the color attributes (L*, chroma, and hue) of Wheat Snack Bread during a 52-week period at 40, 80, 100, 120, and 140°F.....	92
Figure 81. Changes in the appearance of Wheat Snack Bread during a 52-week storage period at 40, 80, 100, 120, and 140°F	93
Figure 82. Changes in the texture of Wheat Snack Bread during a 52-week storage period at 40, 80, 100, 120, and 140°F	94
Figure 83. Changes in the titratable acidity, soluble solids content, and pH of Wheat Snack Bread during a 36-week storage period at 40, 80, 100, 120, and 140°F.....	95
Figure 84. Changes in moisture content and water activity of Wheat Snack Bread during storage for a 52-week period at 40, 80, 100, 120, and 140°F	96
Figure 85. Changes in sugar profiles (sucrose, glucose, fructose, and total sugar) of Wheat Snack Bread during a 52-week storage period at 40, 80, 100, 120, and 140°F.....	97
Figure 86. Changes in maltodextrin content of Wheat Snack Bread during a 52-week storage period at 40, 80, 100, 120, and 140°F	98
Figure 87. Changes in the peroxide value of Wheat Snack Bread during a 52-week storage period at 40, 80, 100, 120, and 140°F.	98
Figure 88. Changes in color attributes (L*, chroma, and hue) of Beef Snack, Sweet BBQ during a 52-week storage period at 40, 80, 100, 120, and 140°F	99

Figure 89. Changes in the appearance of Beef Snack, Sweet BBQ during storage for a 52-week period at 40, 80, 100, 120, and 140°F	100
Figure 90. Changes in the texture of Beef Snack, Sweet BBQ during a 52-week storage period at 40, 80, 100, 120, and 140°F	101
Figure 91. Changes in pH, titratable acidity, and soluble solids content of Beef Snack, Sweet BBQ during a 36-week storage period at 40, 80, 100, 120, and 140°F.....	102
Figure 92. Changes in water activity and moisture content of Beef Snack, Sweet BBQ during storage for a 52-week storage period at 40, 80, 100, 120, and 140°F.....	103
Figure 93. Changes in the sugar profile (sucrose, glucose, fructose, and total sugar) of Beef Snack, Sweet BBQ during a 52-week storage period at 40, 80, 100, 120, and 140°F.....	104
Figure 94. Changes in maltodextrin content of Beef Snack, Sweet BBQ during a 52-week storage period at 40, 80, 100, 120, and 140°F	105
Figure 95. Changes in peroxide value of Beef Snack, Sweet BBQ during a 52-week storage period at 40, 80, 100, 120, and 140°F	106
Figure 96. Changes in color attributes (L*, chroma, and hue) of Applesauce during a 52-week storage period at 40, 80, 100, 120, and 140°F.....	107
Figure 97. Changes in the appearance of Applesauce during a 52-week storage period at 40, 80, 100, 120, and 140°F.....	108
Figure 98. Changes in the texture of Applesauce during a 52-week storage period at 40, 80, 100, 120, and 140°F	109
Figure 99. Changes in pH, titratable acidity, and soluble solid contents of Applesauce during a 36-week storage period at 40, 80, 100, 120, and 140°F	110
Figure 100. Changes in water activity and moisture content of Applesauce during a 52-week storage period at 40, 80, 100, 120, and 140°F.....	111
Figure 101. Ascorbic acid changes in Applesauce during a 52-week storage period at 40, 80, 100, 120, and 140°F.....	111
Figure 102. Changes in sugar profiles (sucrose, glucose, fructose, and total sugar) of Applesauce during a 52-week storage period at 40, 80, 100, 120, and 140°F.....	112
Figure 103. Changes in maltodextrin content of Applesauce during a 52-week storage period at 40, 80, 100, 120, and 140°F.....	113
Figure 104. Changes in color attributes (L*, chroma, and hue) of Italian Pocket Sandwich during a 52-week storage period at 40, 80, 100, 120, and 140°F.....	114
Figure 105. Changes in the appearance of Italian Pocket Sandwich during a 52-week storage period at 40, 80, 100, 120, and 140°F.....	115
Figure 106. Changes in the firmness of Italian Pocket Sandwich during a 52-week storage period at 40, 80, 100, 120, and 140°F	116
Figure 107. Changes in pH, titratable acidity, and soluble solid contents of Italian Pocket Sandwich during a 36-week storage period at 40, 80, 100, 120, and 140°F.....	117
Figure 108. Changes in moisture content and water activity of Italian Pocket Sandwich during a 52-week storage period at 40, 80, 100, 120, and 140°F	118
Figure 109. Changes in ascorbic acid content of Italian Pocket Sandwich during a 52-week storage period at 40, 80, 100, 120, and 140°F	118

Figure 110. Changes in the sugar profile (sucrose, glucose, fructose, and total sugar) of Italian Pocket Sandwich during a 52-week storage period at 40, 80, 100, 120, and 140°F 119

Figure 111. Changes in maltodextrin content of Italian Pocket Sandwich during a 52-week storage period at 40, 80, 100, 120, and 140°F 120

Figure 112. Changes in peroxide value in the whole Italian Pocket Sandwich and meat only during a 52-week storage period at 40, 80, 100, 120, and 140°F 121

Figure 113. Changes in color attributes (L*, chroma, and hue) of Tortillas during a 52-week storage period at 40, 80, 100, 120, and 140°F 122

Figure 114. Changes in the appearance of Tortillas during a 52-week storage period at 40, 80, 100, 120, and 140°F 123

Figure 115. Changes in the texture of Tortillas during a 52-week storage period at 40, 80, 100, 120, and 140°F 123

Figure 116. Changes in titratable acidity, soluble solids content, and pH of Tortillas stored during a 36-week storage period at 40, 80, 100, 120, and 140°F 124

Figure 117. Changes in water activity and moisture content of Tortillas during a 52-week storage period at 40, 80, 100, 120, and 140°F 125

Figure 118. Changes in sugar profile (sucrose, fructose, and total sugar) and maltodextrin content of Tortillas during a 52-week storage period at 40, 80, 100, 120, and 140°F 126

Figure 119. Changes in the peroxide value of Tortillas during storage for 52-weeks at 40, 80, 100, 120, and 140°F 127

Figure 120. Changes in color attributes (L*, chroma, and hue) of BBQ Beef Pocket Sandwich during a 52-week storage period at 40, 80, 100, 120, and 140°F 128

Figure 121. Changes in the appearance of BBQ Beef Pocket Sandwich during a 52-week period at 40, 80, 100, 120, and 140°F 129

Figure 122. Changes in the texture of BBQ Beef Pocket Sandwich stored during a 52-week storage period at 40, 80, 100, 120, and 140°F 130

Figure 123. Changes in pH, titratable acidity, and soluble solid contents of BBQ Beef Pocket Sandwich during a 36-week storage period at 40, 80, 100, 120, and 140°F 131

Figure 124. Changes in moisture content and water activity of BBQ Beef Pocket Sandwich during a 52-week storage period at 40, 80, 100, 120, and 140°F 132

Figure 125. Changes in ascorbic acid content of BBQ Beef Pocket Sandwich during a 52-week storage period at 40, 80, 100, 120, and 140°F 132

Figure 126. Changes in sugar profiles (sucrose, glucose, fructose, and total sugar) of BBQ Beef Pocket Sandwich during a 52-week storage period at 40, 80, 100, 120, and 140°F 133

Figure 127. Changes in maltodextrin content of BBQ Beef Pocket Sandwich during a 52-week storage period at 40, 80, 100, 120, and 140°F 134

Figure 128. Changes in the peroxide value of whole and meat part only of BBQ Beef Pocket Sandwich during a 52-week storage period at 40, 80, 100, 120, and 140°F 135

Figure 129. Changes in color attributes (L*, chroma, and hue) of Dessert Bar, Chocolate Banana Nut during a 52-week storage period at 40, 80, 100, 120, and 140°F 136

Figure 130. Changes in the appearance of Dessert Bar, Chocolate Banana Nut during a 52-week storage period at 40, 80, 100, 120, and 140°F 137

Figure 131. Changes in the texture of Dessert Bar, Chocolate Banana Nut during a 52-week storage period at 40, 80, 100, 120, and 140°F.....	138
Figure 132. Change in pH, titratable acidity, and soluble solid contents Dessert Bar, Chocolate Banana Nut during a 36-week storage period at 40, 80, 100, 120, and 140°F.....	139
Figure 133. Changes in moisture content and water activity of Dessert Bar, Chocolate Banana Nut during a 52-week storage period at 40, 80, 100, 120, and 140°F.....	140
Figure 134. Changes in sugar profiles (sucrose, glucose, fructose, and total sugar) of Dessert Bar, Chocolate Banana Nut during a 52-week storage period at 40, 80, 100, 120, and 140°F.....	141
Figure 135. Changes in peroxide value of Dessert Bar, Chocolate Banana Nut during a 52-week storage period at 40, 80, 100, 120, and 140°F.....	142
Figure 136. Ballot used during training sessions.	146
Figure 137. A screen shot of a typical ballot used for the evaluation of stored FSR.	147
Figure 138. A group of trained panelists evaluating First Strike Ratios.	148
Figure 139. Changes in the quality attributes of Zapplesauce stored at 80°F.....	149
Figure 140. Changes in the quality attributes of Tortilla stored at 80°F.....	150
Figure 141. Changes in the quality attributes of Bacon Cheddar Sandwich stored at 80°F.....	150
Figure 142. Changes in the quality attributes of Beef Snack Barbecue stored at 80°F.....	151
Figure 143. Changes in the quality attributes of Chocolate Banana Nut Dessert Bar stored at 80°F.....	151
Figure 144. Changes in the quality attributes of Italian Style Sandwich stored at 80°F.....	152
Figure 145. Changes in the quality attributes of Filled French Toast stored at 80°F.....	152
Figure 146. Changes in the quality attributes of Wheat Snack Bread stored at 80°F.....	153
Figure 147. Changes in the quality attributes of Honey Barbecued Beef Sandwich stored at 80°F.....	153
Figure 148. Changes in the quality attributes of Zapplesauce stored at 100°F.....	154
Figure 149. Changes in the quality attributes of Tortilla stored at 100°F.....	155
Figure 150. Changes in the quality attributes of Bacon Cheddar Sandwich stored at 100°F.....	155
Figure 151. Changes in the quality attributes of Beef Snack BBQ stored at 100°F.....	156
Figure 152. Changes in the quality attributes of Chocolate Banana Nut Dessert Bar stored at 100°F.....	156
Figure 153. Changes in the quality attributes of Italian Style Sandwich stored at 100°F.....	157
Figure 154. Changes in the quality attributes of Filled French Toast stored at 100°F.....	158
Figure 155. Changes in the quality attributes of Wheat Snack Bread stored at 100°F.....	158
Figure 156. Changes in the quality attributes of Honey Barbecued Beef Sandwich stored at 100°F.....	159
Figure 157. Changes in the quality attributes of Zapplesauce stored at 120°F.....	160
Figure 158. Changes in the quality attributes of Tortilla stored at 120°F.....	160
Figure 159. Changes in the quality attributes of Bacon Cheddar Sandwich stored at 120°F.....	161
Figure 160. Changes in the quality attributes of Beef Snack BBQ stored at 120°F.....	161
Figure 161. Changes in the quality attributes of Chocolate Banana Nut Dessert Bar stored at 120°F.....	162
Figure 162. Changes in the quality attributes of Italian Style Sandwich stored at 120°F.....	162
Figure 163. Changes in the quality attributes of Filled French Toast stored at 120°F.....	163
Figure 164. Changes in the quality attributes of Wheat Snack Bread stored at 120°F.....	163

Figure 165. Changes in the quality attributes of Honey Barbecued Beef Sandwich stored at 120°F..... 164

Figure 166. Changes in the quality attributes of Zapplesauce stored at 140°F..... 165

Figure 167. Changes in the quality attributes of Tortilla stored at 140°F..... 165

Figure 168. Changes in the quality attributes of Bacon Cheddar Sandwich stored at 140°F 166

Figure 169. Changes in the quality attributes of Beef Snack BBQ stored at 140°F..... 166

Figure 170. Changes in the quality attributes of Chocolate Banana Nut Dessert Bar stored at 140°F 167

Figure 171. Changes in the quality attributes of Italian Style Sandwich stored at 140°F..... 168

Figure 172. Changes in the quality attributes of Filled French Toast stored at 140°F..... 168

Figure 173. Changes in the quality attributes of Wheat Snack Bread stored at 140°F 169

Figure 174. Changes in the quality attributes of Honey Barbecued Beef Sandwich stored at 140°F..... 169

Figure 175. The interpolation of quality index value for the appearance of Zapplesauce at 120°F..... 173

Figure 176. The plot that shows how much QI will drop depending on previous QI value, temperature and time 174

Figure 177. The spline interpolation for the drop in QI value vs. temperature relation 175

Figure 178. The logarithmic-linear interpolation for the drop in QI vs. temperature relation 176

Figure 179. Graphical representation of the quality matrix for one of the product-quality pairs 177

Figure 180. Complete flow diagram for the shelf life estimation algorithm 178

List of Tables

Table 1. Results of 80% Requirement Range Span Testing.....	15
Table 2. Results of Extended Limit Requirement Testing	17
Table 3. Results of Freezing temperature Testing	18
Table 4. Results of Two-Point Swing Testing	20
Table 5. Results of Truck Mode Vibration Testing with 104°F to 5°F Temperature Profile.....	24
Table 6. Results of Rail Mode Vibration Testing with 104°F to 5°F Temperature Profile.....	25
Table 7. Results of Air Mode Vibration Testing with 104°F to 5°F Temperature Profile	27
Table 8. Results of Truck Mode Vibration Testing with 59°F to 118.4°F Temperature Profile.....	27
Table 9. Results of Rail Mode Vibration with 59°F to 118.4°F Temperature Profile	28
Table 10. Results of Air Mode Vibration with 59°F to 118.4°F Temperature Profile.....	29
Table 11. Results of Sine Mode Vibration Tests at 118.4°F, 89.6°F, 59°F, 32°F, and 5°F.....	30
Table 12. Results of Caen Range Testing	32
Table 13. Results of Intelleflex Range Testing	33
Table 14. CAEN Tag Status Readings and Descriptions.....	44
Table 15. First Strike Ration Menus	69
Table 16. Physical and Compositional Evaluation Schedule	72
Table 17. Frequency of sampling at each storage temperature.....	148
Table 18. Weeks of storage before the mean overall quality score drops below 4.0	170
Table 19. Example of Zapplesauce Taste Panel at 120°F	172
Table 20. Equipment Record.....	180

Preface

This report details a Phase 1 effort conducted by the University of Florida and the University of South Florida Polytechnic as part of a multi-year, multi-phase project entitled “Remote Environmental Monitoring and Diagnostics in the Perishables Supply Chain.” This work was conducted during the period October 2008 to December 2010 under a Broad Agency Announcement Contract (# W911QY-08-C-0136) awarded by the Natick Soldier Research, Development, and Engineering Center (NSRDEC) to the University of Florida. Efforts involved the investigation and application of various technologies including wireless temperature sensors, remote monitoring using radio frequency identification (RFID), algorithms, and diagnostics, to demonstrate that ration shelf life can be automatically calculated in real time using web-based computer models.

The findings contained in this final project report are not to be construed as an official Department of the Army position unless so designated by other authorized documents. Citation of trade names in this report does not constitute an official endorsement or approval of the use of such items.

This comprehensive research program was made possible through the joint cooperation and collaboration of the following individuals:

Jeffrey K. Brecht, Ph.D., University of Florida, Project Coordinator

Jean-Pierre Émond, Ph.D., University of South Florida Polytechnic, Objective 1 Director

M. Cecilia N. Nunes, Ph.D., Univ. of South Florida Polytechnic, Objective 2 Co-Director

Charles A. Sims, Ph.D., University of Florida, Objective 2 Co-Director

Pavlos Tsouvaltzis, Ph.D., University of Florida, Research Program Coordinator

Ismail Uysal, Ph.D., University of South Florida Polytechnic, Objective 1 Associate

Asli Odabasi, Ph.D., University of Florida, Objective 2 Associate

Yavuz Yagiz, Ph.D., University of Florida, Objective 2 Associate

Gisele Bennett, Ph.D., Georgia Institute of Technology, Subcontractor

Jeffrey L. Wells, Franwell Inc., Subcontractor

Executive Summary

Scientific and Technical Achievements

- *The goal of this project was to identify sensor-equipped RFID technology and develop automated knowledge system capability to determine the remaining shelf life of operational rations in the Department of Defense (DoD) supply chain based on remotely monitored temperature history.*

Shelf-stable (semi-perishable) combat rations are essential for enabling the individual Warfighter to perform assigned missions and survive battlefield threats. The current family of rations [Meal, Ready-to-Eat (MRE) and First Strike Rations (FSR)] has been developed and designed to have sufficient shelf life under normal storage conditions (2 to 3 years at 80°F and 6 months at 100°F), however, under high temperature conditions there is significant degradation of the quality and nutrient content of those rations. Extreme high temperatures can shorten their shelf life so drastically that the concept of providing perishable food products to the battlefield is almost impossible.

The introduction of highly functional, sensor-equipped radio frequency identification (RFID) tags in the DoD supply chain can significantly improve food quality, safety, and security. In addition these new technologies can play an important and significant role in supply chain management. This project, performed jointly by the University of Florida (UF)/ Institute of Food and Agricultural Sciences (IFAS) Center for Food Distribution & Retailing (CFDR) and the U.S. Army Natick Soldier Research, Development & Engineering Center (NSRDEC), and later on with the University of South Florida Polytechnic, sought to exploit that additional functionality in order to improve military logistics, while simultaneously providing valuable improvement opportunities for commercial food distribution and retailing.

- *By using wireless temperature sensors, remote monitoring (RFID), algorithms, and diagnostics, it was demonstrated that FSR shelf life can be automatically calculated in real time using web-based computer models. A fully functional prototype RFID system was developed during this project as a result of extensive testing. Intellex tags were selected because they showed high accuracy in both temperature accuracy and environmental simulation tests, had a longer communication range than other tested tags, and are based on an advanced class 3 communication protocol, making them future-ready in terms of adaptability to other systems and RFID readers.*

With this knowledge, logisticians can better plan for a steady flow of rations and other food supplies to support Warfighters in various theaters of operation despite products potentially encountering extreme environmental conditions during transit. It is our hope that this knowledge can result in reduced losses due to heat stressed rations, as well as reduced inspection time to determine ration serviceability.

For maximum applicability to the currently existing military supply chain, this project was focused on developing a prototype system for front end temperature data collection using

commercially available RFID tags and commercial handheld readers. This data was used in conjunction with shelf life models developed for nine selected FSR menu items to calculate remaining shelf life.

- *The quality and shelf-life of selected FSR menu items when exposed to extreme ambient temperatures was determined using measurements of the physical and compositional characteristics of the products and evaluation of the sensory quality. The results of these measurements and evaluations provided data for development of algorithms to iterate each quality factor for each FSR menu item with specific time increments. The algorithms were validated and calibrated, and software was developed for models to predict remaining shelf life from a handheld reader.*

A long term vision associated with this project was to eventually integrate FSR automated shelf life data into the US Army Veterinary Command Inspection Database. Subsequently a web-based system was investigated in order to provide real-time visibility of remaining shelf life of operational rations throughout the DoD supply chain.

- *As a result of this project, the NSRDEC, Combat Feeding Directorate now has an RFID based portable solution to monitor and track the environmental temperature of FSR for accurate estimation of remaining shelf life prior to consumption.*

REMOTE ENVIRONMENTAL MONITORING AND DIAGNOSTICS IN THE PERISHABLES SUPPLY CHAIN - PHASE I

1 Objective 1 – Evaluation, Selection and Development of a Prototype, Sensor Enabled, Radio Frequency Identification (RFID) System for Temperature Tracking and Shelf Life Monitoring of First Strike Rations¹

1.1 Introduction

First Strike Rations (FSR) can be classified as “semi-perishable” as they have approximately a two year shelf life when stored under normal storage conditions (80°F). However, under high temperatures, a significant degradation occurs in the quality and nutritional content of FSR. Considering the crucial importance of FSR, as they are essential for enabling the Warfighter to perform assigned missions and survive battlefield threats, it is extremely important to quantify the degradation in FSR quality after a prolonged exposure to high temperatures.

This project considers implementation of a temperature sensor equipped radio frequency identification (RFID) system to the Department of Defense (DoD) supply chain to significantly improve food quality, safety and security. By using RFID tags with temperature sensing capabilities, a shelf life estimation algorithm can be utilized at the distribution point to calculate the remaining shelf life of FSR when exposed to effects of both time and extreme high temperature. This will ultimately lead to supply chain logisticians planning for a steady flow of rations and other food supplies to support the Warfighter in various theaters of operation despite the products potentially encountering extreme environmental conditions during their transit. However, the first phase of the project, as detailed in this final report, will concentrate on determining the shelf life of the product prior to consumption. In order to accomplish this task, the Objective 1 team focused on developing a self-contained system for temperature recording and shelf life estimation using commercially available RFID tags and handheld readers for maximum applicability to the existing military supply chain.

One of the most important goals of the project was to select a commercially available temperature sensing RFID tag that can withstand the extreme environmental conditions such as temperature and vibration during the transportation of the FSR. The Objective 1 team has gone through an extensive market review to identify and down select candidate technologies that satisfied the majority of the project requirements. In order to efficiently compare the possible solutions, a testing protocol has been developed that not only compares the accuracy of the

¹ Prepared by: Ismail Uysal, Ph.D., University of South Florida Polytechnic, Lakeland, FL

tags but also the reliability under extreme temperatures and vibration. The proposed standard testing protocol for sensor tags also includes a performance metric based on temperature accuracy and a requirement driven test scheme to determine reliability.

In addition to accuracy and reliability testing, the candidate technologies have undergone other performance tests such as read range testing and battery life testing. Based on the reality that a typical FSR package includes liquids and metal packaging, which presents RFID technical performance challenges, temperature estimation models have been developed to more accurately represent the temperature inside the FSR pallet with a temperature logger placed outside.

Since the ultimate goal of the project is to estimate the shelf life of an FSR pallet based on temperature history, a shelf life algorithm was developed based on two-dimensional cubic spline and exponential interpolation of experimental taste panel data for different temperatures.

Finally, application software has been developed for two candidate technologies, A927Z tags from Caen RFID based in Italy, and TMT-8500 tags from Intellex based in California, USA. Both prototype systems have been demonstrated to operate successfully during the project wrap-up meeting in Lakeland, Florida on December 8th, 2010.

This Objective 1 section of the final report includes:

- ⇒ Project definition and key system requirements
- ⇒ Market search and selection of candidate technologies based on system requirements
- ⇒ The novel environmental testing protocol for reliability and accuracy analysis of candidate technologies
- ⇒ Results for each of the tests included in the protocol for three manufacturers
- ⇒ RFID tag read range testing and associated results
- ⇒ Context based accuracy metric developed to identify the most accurate technology
- ⇒ Preliminary temperature estimation studies to model inside temperature of FSR pallets using only the outside temperature data
- ⇒ Shelf life model construction based on taste panel data at different temperatures
- ⇒ System specifications and detailed operating manuals for two prototype systems
- ⇒ Conclusions: validation and final recommendations.

1.1.1 Objective 1 Team

A diverse team of scientists and engineers have worked together to deliver two fully functional prototype systems equipped with RFID technology to track the environmental temperature of FSR during transportation and storage to estimate the shelf life prior to consumption for enhanced product acceptability, nutrition and increased safety.

- ⇒ Dr. Jean-Pierre Émond – University of South Florida Polytechnic, Lakeland, FL
- ⇒ Dr. Ismail Uysal – University of South Florida Polytechnic, Lakeland, FL

- ⇒ Dr. Gisele Bennett – Georgia Institute of Technology, Atlanta, GA
- ⇒ Jeffrey Jo – Georgia Institute of Technology, Atlanta, GA
- ⇒ Jeffrey Wells – Franwell, Inc., Lakeland, FL
- ⇒ John Stephens – Franwell, Inc., Lakeland, FL
- ⇒ Praveen Limbachiya – Franwell, Inc., Lakeland, FL

1.2 Project Definition and Key Requirements

Before the project activities can be described in greater detail, the project needs to be defined along with some of the key system requirements that limit the list of potential technology candidates for the solution.

The main purpose of this study is to implement RFID temperature tags in the supply chain of FSR to significantly improve food quality, safety and distribution. In other words, an RFID based portable solution to monitor and track the environmental temperature of FSR for accurate estimation of remaining shelf life prior to consumption. One of the most important goals of the project is to pick a commercially available temperature sensing RFID tag that can withstand the extreme environmental conditions such as temperature and vibration during the transportation of the FSR that accurately reflect the rigors and stressors of the military supply chain. In order to efficiently compare the possible solutions, a testing protocol must be developed that will not only compare the accuracy of the tags but also the reliability under extreme temperatures and vibration, which in turn formed the basis of the academic research described in this report.

Recent developments in RFID-enabled sensors along with decreasing price levels have opened many application possibilities such as tracking the temperature of heat sensitive products during transportation or accessing accurate remaining shelf life data for fresh produce at distribution points. However, unlike simple ID tags, for which the price tag seems to be the governing attribute, there needs to be a common standard for testing and assessing the reliability and accuracy of temperature tags to come up with an objective comparison scheme to pick the best possible solution for a specific project. Since every application will be defined by its requirements, the common standard must have requirement driven parameters to ensure applicability to different operational scenarios.

Hence, in order to evaluate different technologies on the market, one needs to take into account the project requirements. The most crucial requirements for the project mandated by Natick Research, Development, and Engineering Center (NSRDEC) can be summarized as follows:

- ⇒ RFID tags with the temperature sensors should be able to withstand temperatures between -22°F and 140°F.
- ⇒ The RFID system should operate at Ultra High Frequency (UHF), preferably at 915MHz to be compatible with other wireless technologies already in place.
- ⇒ The commercially available RFID handheld reader and the tags should communicate using a standard and passive protocol.



- ⇒ A battery life of 3 years for the RFID tags to properly record the entire temperature history.
- ⇒ The solution needs to be portable and fully stand-alone. It should assume the link to a mainframe is never guaranteed and all the software should be included in the handheld or the tag.
- ⇒ The read range from the sides of the pallet should be at least 6 to 10 feet.
- ⇒ The cost of the tag should be in the vicinity of \$15-\$25.
- ⇒ The cost of the portable RFID reader cannot exceed \$5,000.

1.3 Evaluation and Selection of the Right Wireless Technology

1.3.1 Market Search

Based on the aforementioned requirements, the first goal of the Objective 1 team was to conduct an extensive market search to evaluate different technologies and choose the ones to be evaluated further through environmental accuracy and reliability testing. Throughout the entirety of the first phase, the market search and review never ceased as RFID technologies, especially sensor-based hardware, constantly evolved. A great example of this is the fact that while two of the technologies that we picked for further evaluation (Caen and Infratab) were on the market when the project first started, the third technology (Intellex), one of those which we actually recommend for application, was not readily available on the market until late 2010.

Below are some of the wireless temperature tracking technologies on the market and reasoning behind why only a select few were chosen for further, more comprehensive, evaluation:

- ⇒ **Caen:** These tags operate at 915 MHz, and satisfy most of the project requirements except the low temperature threshold of -22°F. They use Class 1 Gen 2 communication protocol, which is a standard and passive communication protocol. They have a battery life of approximately 3 to 5 years with 8000 sample memory for temperature samples. Their manufacturer claimed accuracy is +/-0.18°F. They have a durable casing to protect the circuitry and the temperature sensor inside. This is one of the manufacturers picked for further evaluation. 
- ⇒ **Evidencia:** These tags operate at 13.56 MHz, high frequency (HF) band and in this regard do not satisfy one of the key requirements. However, they have a 64,000 sample memory, which can be crucial for products like fresh produce. Since it is an HF temperature tag, it requires close range for communication. 
- ⇒ **Gentag:** These tags also operate at 13.56 MHz HF band with close range communications. They have both passive and battery assisted versions for increased reliability in communication between tags and readers. 

They are compatible with near field communication (NFC) devices such as some of the smart phones.

⇒ **Identec:** Identec is one of the leading companies in developing wireless temperature tracking solutions. Their i-Q350TL SL tags have more than 6 years of shelf life, provide superior accuracy as well as greatly increased read range over its passive competition. In addition, it operates at 915MHz UHF frequency band, which would make it a great candidate technology for the project if it wasn't for the fact that the tags and readers use an active communication standard. In other words, the tags actively beacon their identification codes and any information stored in the memory in the vicinity of a reader, which fails to satisfy one of the key project requirements.



⇒ **Infratab:** These tags satisfy a majority of the key requirements such as operating at UHF 915MHz, having standard passive communication controls, -13°F to 158°F temperature sensor range, etc. However, they have limited memory that can only store 100 pairs of temperature and time stamps. This was the second technology chosen for further evaluation since it doesn't openly fail or violate any of the key requirements.



⇒ **Intelleflex:** Intelleflex has recently come out with their newest addition to temperature monitoring RFID tags. Similar to Caen and Infratab, TMT-8500 also satisfies all the key requirements with its battery life, operating frequency band, read range and temperature sensor range, and standard and passive communication protocol. In addition to these, TMT-8500 tags also operate on the new class 3 protocol, which provides a much more reliable link between the reader and the tag, resulting in greatly improved read range over its competitors. Intelleflex has been chosen as the third and last technology for further evaluation.



⇒ **Savi:** Savi has multiple RFID temperature tags with the majority of the technical specifications satisfying the key project requirements. However, like the Identec tags, they are active tags and operate on a different (yet standard) communication protocol called ISO 18000-7. Since the candidate technology should have a passive link between the reader and the tag as one of the requirements, Savi was not picked for further evaluation.



⇒ **Sensitech and Stepac:** Sensitech's TempTale RF product and Stepac's Xsense system are similar in the way they monitor the temperature of a shipment and have a base module (with satellite communication option to show the temperature and location of the container in real time) to communicate with the tags. Even though both systems are capable of monitoring extreme temperatures reliably, the fact that they use an active link between the reader and the tags as well as non-standard, proprietary



protocols will limit their applicability to the project solution due to lack of some of the key requirements.

1.3.2 Environmental Testing Protocol – Procedure, Results and Discussion

The overall protocol consists of two main parts. The first part considers the simulation of environmental characteristics during the transportation of the product as well as the measuring of temperature accuracy within the requirement range. The second part introduces the context based accuracy metric, which will combine the shelf life specifics of the product and the temperature accuracy of the tag to find an objective and quantitative performance measure to be associated with each tag under test.

The development of the proposed testing protocol would not be possible if it wasn't for the unique test setup designed by the team of Dr. Émond and his research assistant. While it is not uncommon for tag manufacturers to perform certain vibration tests while designing their products, in real life the reliability of the tag, such as the integrity of the battery contact, strongly depends on the environmental temperature during transportation vibration. Hence, an environmental vibration chamber has been designed and manufactured to realistically simulate not only the vibration during transportation but the temperature as well.

Figure 1 and Figure 2 show the environmental test chamber that was used during the testing of candidate technologies.



Figure 1. Environmental test chamber from the outside



Figure 2. Environmental test chamber with the door open

The vibration table is located in the middle of the chamber as shown in Figure 3. The height of the chamber allows for double stacking pallets; however, the table is only able to vibrate one full pallet load. Due to forces created by the table actuator during vibration tests, the seismic base of the table should be de-coupled from the building structure and thus housed in a pit about three feet deep into the ground. This creates another challenge where the inside of the chamber must be isolated in order to block any outside heat or cold coming into the chamber from the seismic base of the vibration table. Figure 3 shows the solution that was designed to overcome this problem by employing two moveable metal platforms on hinges with custom-cut holes corresponding to 1G supports and the piston of the table to allow vibration with minimal friction.

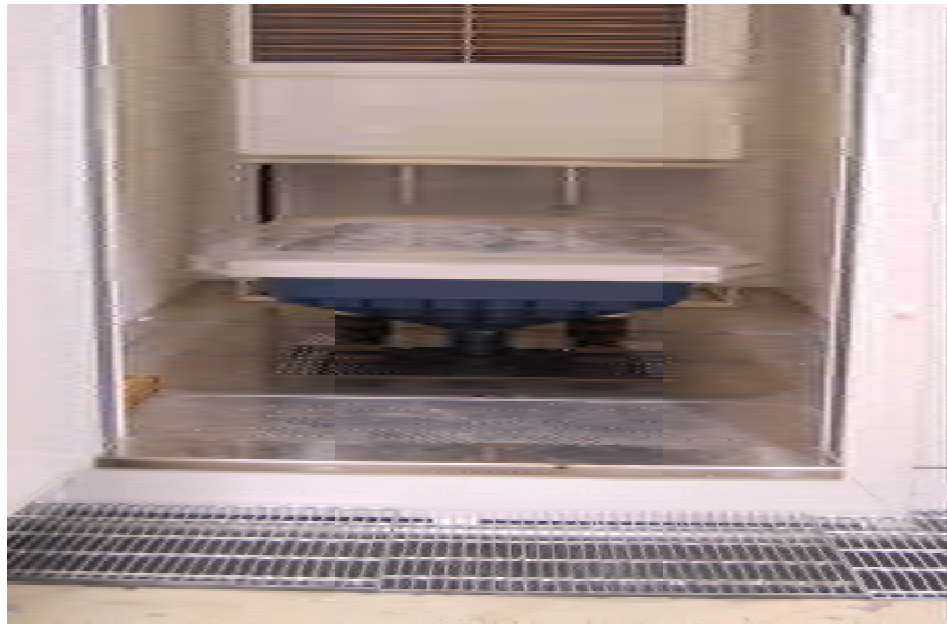

Figure 3. A close-up view of the inside of the environmental test chamber

The temperature chamber used in the experiments is manufactured by Conviron with model number C1010. Its temperature range is -31°F to 140°F. It can simulate sudden changes in temperature with a 30 minute gradient between its highest and lowest temperatures. The vibration table is manufactured by Lansmont with model number 6200. It can vibrate payloads up to 1361 kg and has a maximum stroke of 15.2 cm. Its frequency range is between 2-300 Hz, which allows the simulation of all standard vibration curves that can be encountered during transportation. The unique setup allows the user to simulate real life vibration profiles for various target modes at different temperatures to achieve a higher and more realistic level of testing standard than regular vibration tests.

In developing the testing standard for temperature tags, the two important features are adaptability and modularity. In other words, the proposed protocol should not only be applicable to any problem with the necessary parameters but also should be open ended to allow future modifications and integration of other test schemes. For instance, there are some specifications of the tag such as read range with different readers, memory read speed, battery life, etc. that are common with regular ID tags. However, creating a testing standard for every possible specification is beyond the scope of this project, which concentrates on the accuracy and reliability of sensory tags instead. However, the modular design of the testing protocol allows for augmentation of such testing schemes to the protocol if the application demands it.

The overall protocol can be explained in two major groups: temperature based and environmental simulation (both temperature and vibration) based.

1.3.3 Temperature Based Accuracy Testing

The protocol looks at both the population behavior of tags for mean accuracy and overall performance and the individual tags to check for irregularities in temperature recording. For each test explained below, the following initialization and data harvesting stages are the same.

- 1) Determine tag population size and record it. More tags will result in better statistical results.
- 2) Determine the number of cross-reference sensors and record it. (For tests in this project, high accuracy calibrated Hoboware U12 loggers were used)
- 3) Initialize the tags by clearing memory and initializing the internal clock.
- 4) Set the temperature sampling rate.
- 5) Start the tags.
- 6) Place tags in the temperature chamber.
- 7) Run test schedules A, B, C or D as explained below.
- 8) Retrieve tags from the temperature chamber.
- 9) Stop the tags.
- 10) Read and record memory.
- 11) Process the temperature data into PC for further statistical analysis.

The following subsections will explain the different test schedules that must be run to ensure operability under the required temperature range. Since the requirement limits (extreme low or high temperatures) pose the biggest problem, there are four different test schedules for thorough analysis as explained below.

Before we explain the protocol, it is critically important to mention the following aspects related to each experiment:

- ⇒ The sampling instants of RFID tags and reference sensor logs should always overlap perfectly prior to statistical analysis. Even a couple minutes of difference between timestamps will greatly affect the accuracy results.
- ⇒ Different sampling rates were used for different manufacturers based on memory limitations and other factors. In order to ensure the same reference sensor can be used for each manufacturer, the reference sensors were set to have a 1 minute sampling rate and then down sampled accordingly based on the sampling rate of RFID tags for each experiment.
- ⇒ Caen and Intellex tags, based on the type of testing, were set at either 1-minute or 5-minute sampling rates.
- ⇒ Infratab tags, based on the type of testing, were set at 60-minute, 15-minute or 1-minute sampling rates.

Since each tag manufacturer defines their temperature accuracy in Celsius, the following test protocol uses temperatures based on Celsius to define some of the test parameters. However, at NSRDEC's request, all the temperatures in the following analysis sections are presented in Fahrenheit, except for the figures generated by the test software.

Figure 4 shows the relationship between Celsius and Fahrenheit, as well as the requirement range of the project as denoted by the arrows. Readers can use this figure as a quick reference to the relationship between Fahrenheit and Celsius values when viewing the graphical analysis plots.

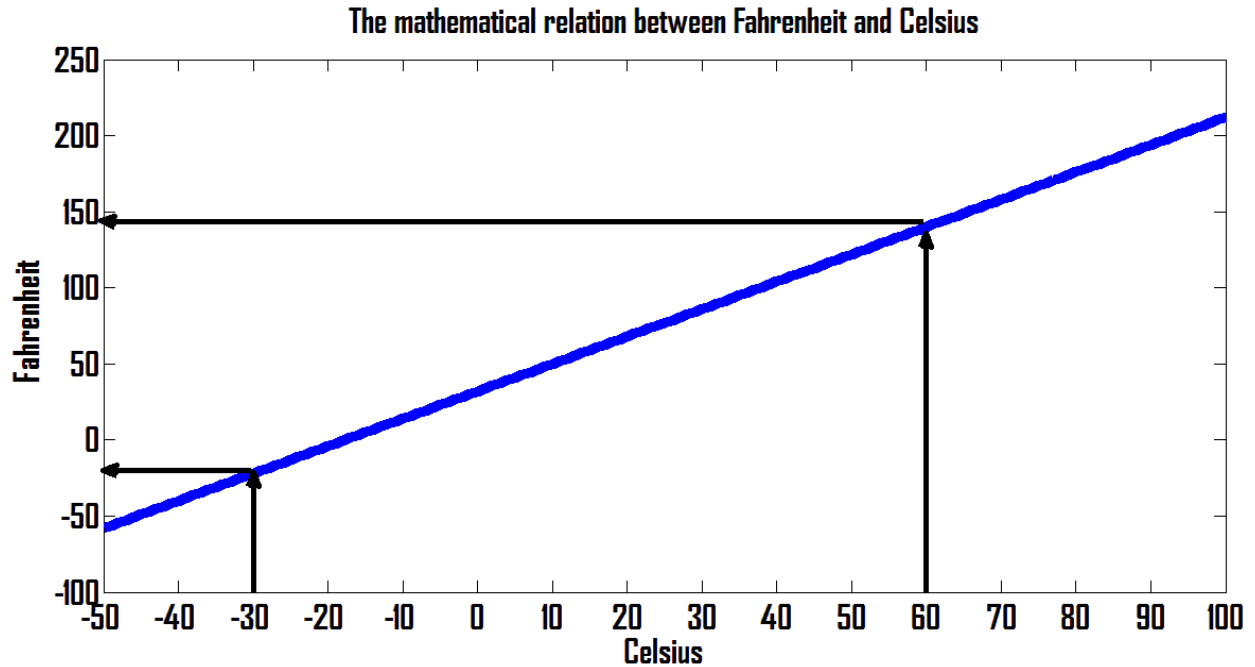

Figure 4. Relationship between Celsius and Fahrenheit

1.3.3.1 80% Requirement Range Span Testing (Schedule A)

This is a full 24-hour test where the highest and lowest temperatures of the test schedule are set at 10% below the requirement limits. The temperature is then changed from high to low uniformly with a proper rate of change to complete the full cycle within 24 hours. The main purpose of this test is to check the overall accuracy of the tag population within the majority of requirement range. Since our requirement limits for this project are 140°F and -22°F, the high and low temperature limits in this testing will be 130°F and -16.6°F.

Caen Tag Results:

For this test, Caen tags were set to sample every 5 minutes. Figure 5 shows the results of one such test performed with Caen RFID tags. The top left corner shows the average temperature recording of all RFID tags compared to the reference sensor. As observed from Figure 4 the tags had a mean square error of roughly 2.62°F, which is mostly due to the fact that tags are missing sampling instants. If one looks at the beginning of the test, the tag and reference sensor output matches well, whereas towards the end RFID tag output seems to “lead-in-time”, which is physically impossible. This serves as an indication that the tag has started missing sampling instants especially at subzero temperatures. The statistical figures in the middle of the figure stand for the following: mean-square error (MSE), standard deviation (STD) and cross-correlation coefficient (Corr.). MSE and STD are commonly used performance metrics to compare a test system output with a reference output. The cross-correlation coefficient is useful in comparing the overall shape of the temperature curves. Higher cross-correlation coefficients indicate more similar outputs. For example, the cross-correlation coefficient of the reference sensor log with itself will always give a value of 1, meaning there is perfect correlation between the two, since the temperature curves are identical.

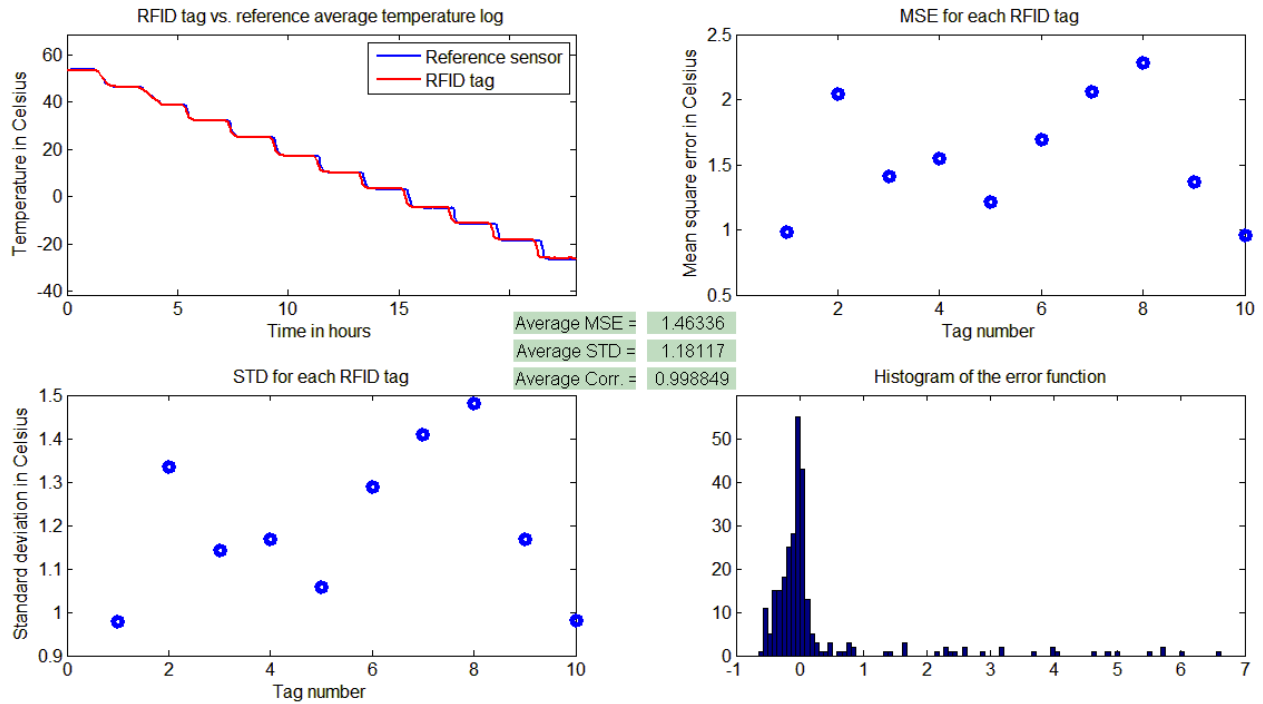

Figure 5. Overall performance results for 10 Caen tags for 80% requirement range span testing

If one looks at the individual Caen logs, it is easy to see that this behavior is more evident for some tags than others. Figure 6 shows the individual output plots for Caen tags. For example, if one compares tag #4 and tag #5, it is easy to observe that tag #4 has skipped more sampling instants. This might be an important issue especially when the temperatures fall below freezing because a typical recording session for each individual tag will last between 1 and 2 years. The shift in time and sampling instants will accumulate over this duration and may interfere with the accuracy of the shelf life algorithm.

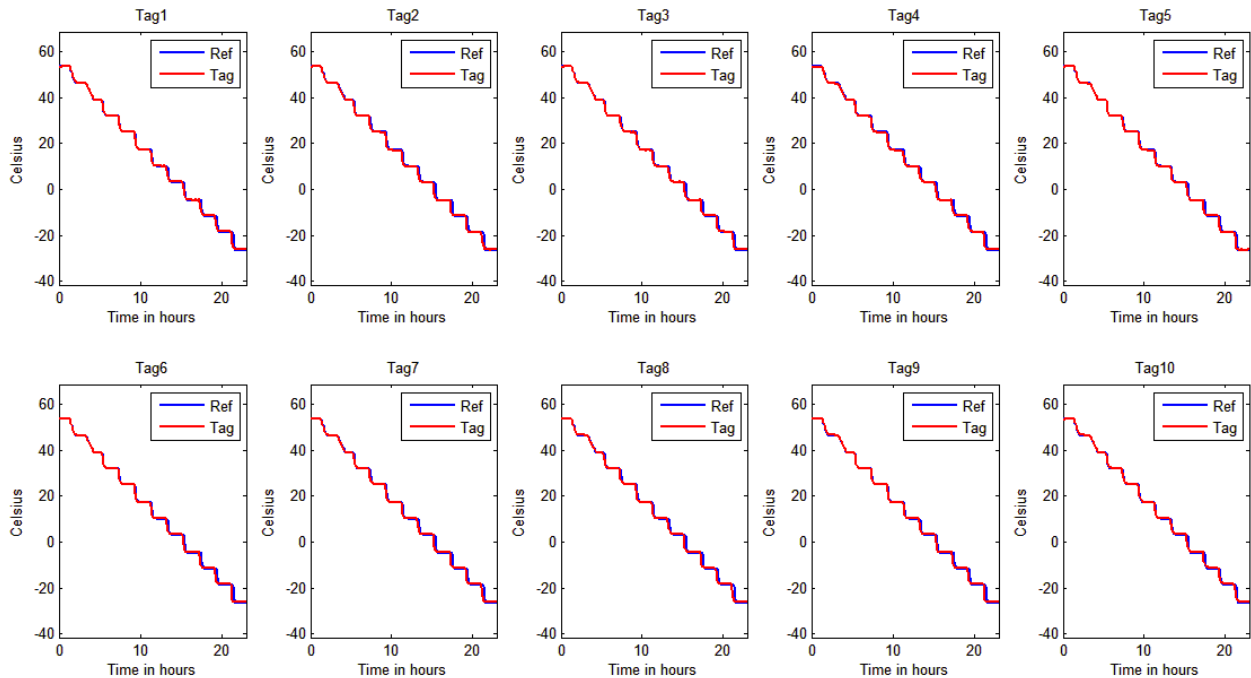

Figure 6. Individual Caen tag temperature logs for 80% requirement range span testing

Infratab Tag Results:

For this test, Infratab tags were set to sample every 15 minutes. Figure 7 shows the results for tags manufactured by Infratab. It is important to mention that Infratab tags freeze at temperatures below freezing (more on this in the following sections). Thus, for this particular experiment only the temperature regions above 32°F are displayed.

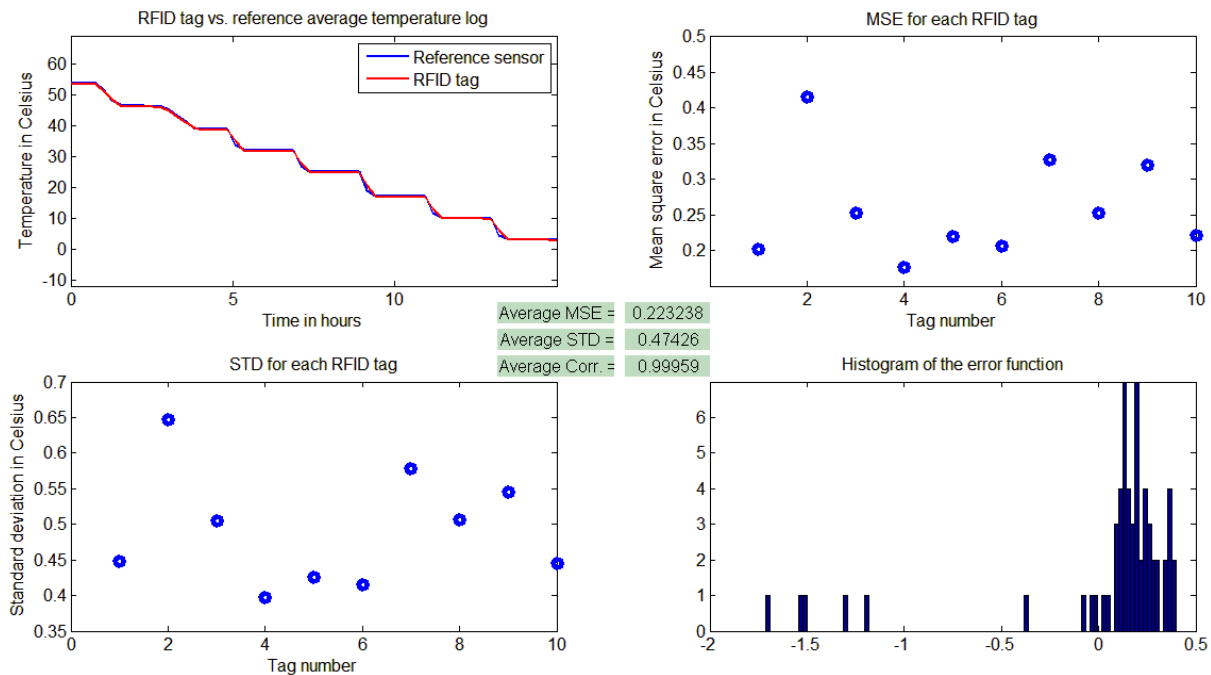

Figure 7. Overall performance results for 10 Infratab tags for 80% requirement range span testing

The average MSE in this case is 0.396°F and much lower than Caen tags, however it is important to note that Infratab tags were unable to record temperatures below freezing. A slight delay can be observed between the reference tag and the RFID tag as the red line follows the blue line. If you look at the MSE and STD distributions for each tag, they are fairly close to each other indicating that no particular tag performed significantly worse than the others. The error histogram on the bottom right corner shows that the majority of errors are positive, which means the RFID tag measured the temperature less than it actually was. The error samples in the large negative zone (around -3.6°F and -2.7°F) are due to the fact that the temperature log delays the reference log especially in temperature transition intervals.

Figure 8 shows the individual outputs for each Infratab tag compared to the reference log. There is no individual tag with a significantly worse performance than the others.

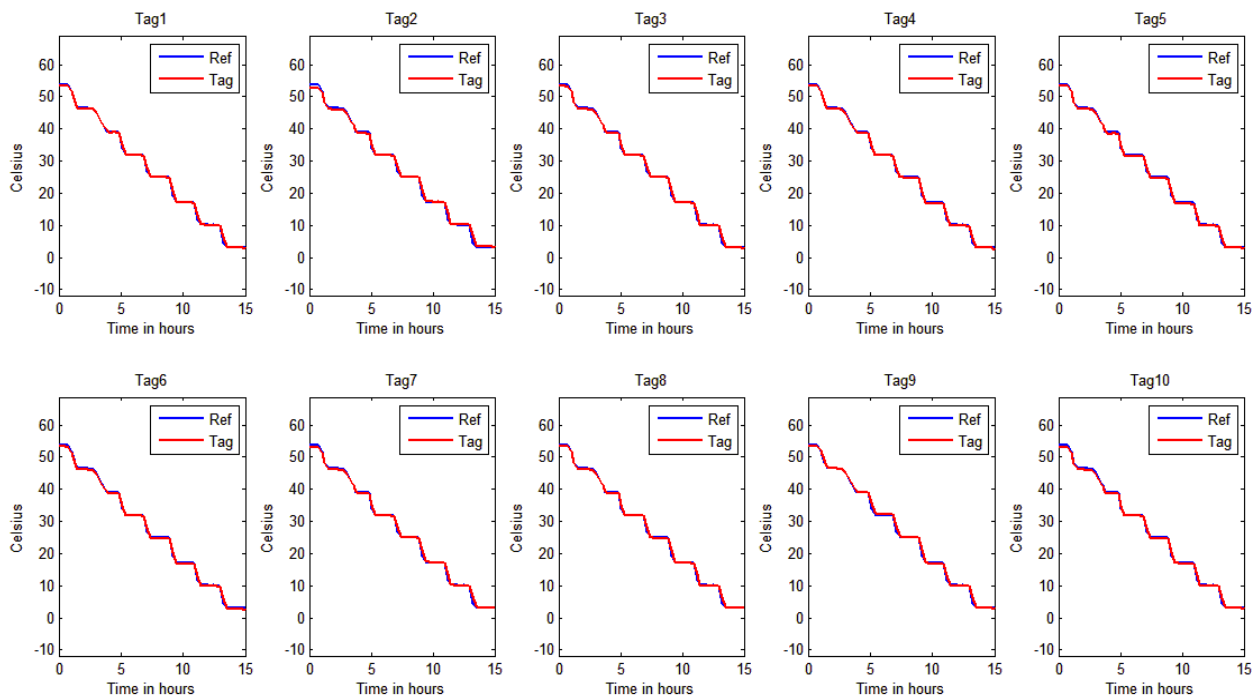

Figure 8. Individual Infratab tag temperature logs for 80% requirement range span testing

Intellex Tag Results:

For this test, Intellex tags were set to sample every 5 minutes. Figure 9 shows the results for tags manufactured by Intellex.

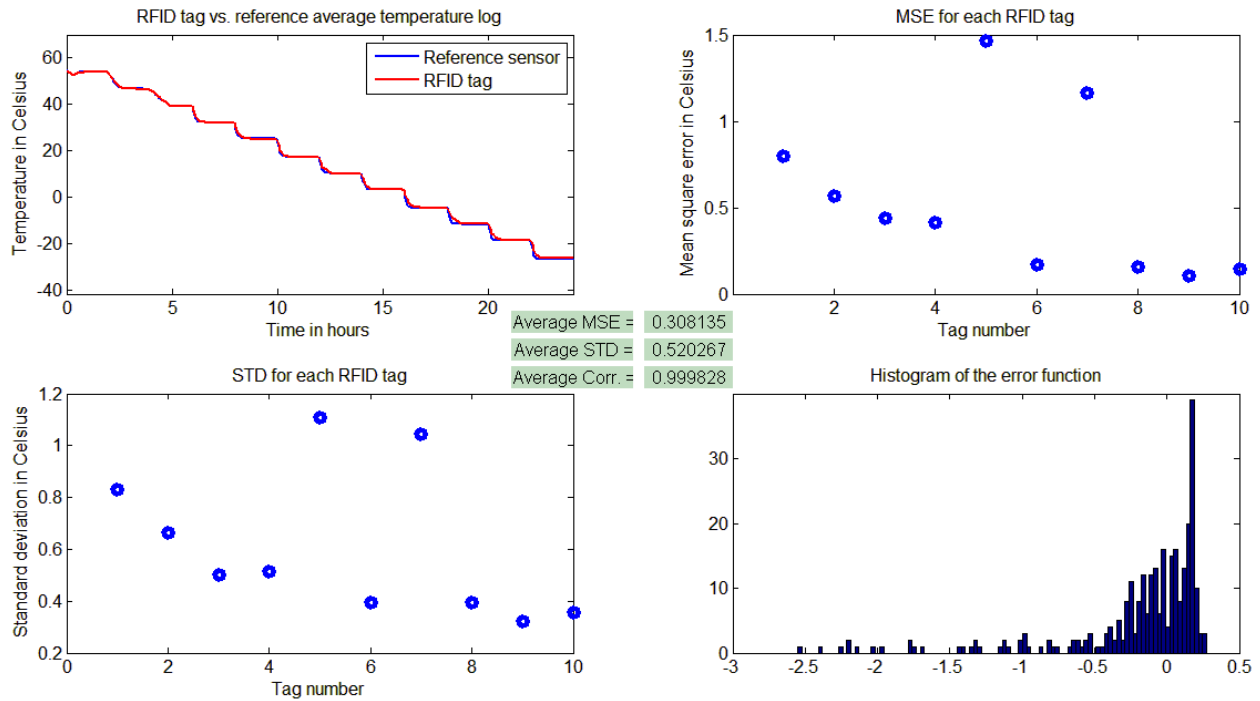

Figure 9. Overall performance results for 10 Intellex tags for 80% requirement range span testing

The average MSE for Intellex tags, 0.54°F , is significantly lower than Caen tags and comparable to Infratab tags. However, Intellex tags were not frozen at any point and were able to record the entire temperature log successfully. Similar to Infratab tags, there is a slight delay between the reference and RFID tag output during temperature transitions. This is also evident from the error histogram on the bottom right corner. When we look at the individual tag behavior on the top right corner, we can observe that the MSE for tags 5 and 7 are higher than the rest of the population. This can also be seen in Figure 10 where tags 5 and 7 have a greater delay in temperature transition. However, both tags were still able to follow the entire temperature history successfully.

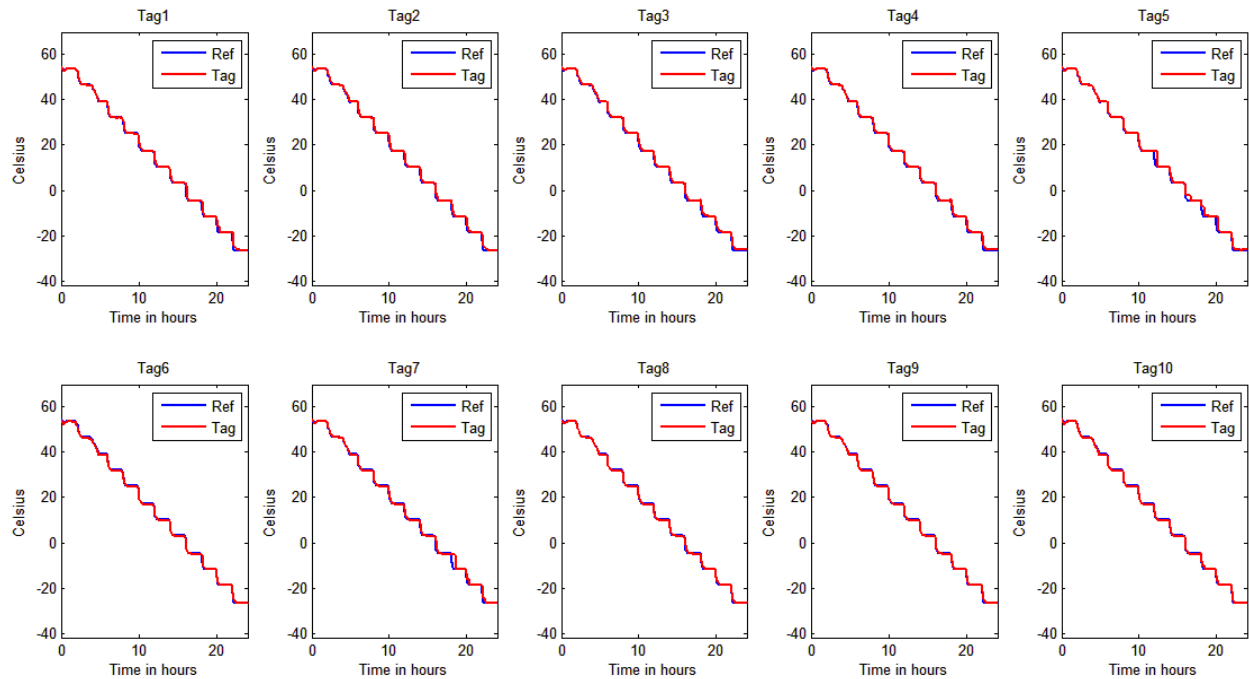

Figure 10. Individual Intellex tag temperature logs for 80% requirement range span testing
 The results can be summarized as shown in Table 1.

Table 1. Results of 80% requirement range span testing

	MSE	STD	Corr.
Caen	2.63°F	2.12°F	0.998849
Infratab (not frozen)	0.40°F	0.85°F	0.99959
Intellex	0.56°F	0.94°F	0.999828

Please note that in none of the experiments above was there an instance in which an individual tag performed significantly worse than the other tags belonging to the same manufacturer. The same observation holds true for all the rest of the testing discussed in this section, and thus the graphical results will be used mainly to explain the temperature profiles for each experiment while numerical results will be provided for quantitative performance comparison.

In Appendix A, the reader can find a summary of all the numerical analyses for each environmental testing profile discussed in this section.

1.3.3.2 Extended Requirement Limit Testing (Schedule B)

This is another full 24-hour testing where the chamber is started at the high requirement limit (in this case 140°F) for an extended period of time (8 hours) while the reference sensors and RFID tags are recording the temperature. Then, the temperature is decreased 10% below the maximum requirement limit (in this case 129.2°F) for a relatively shorter period of time (4 hours). A sharp transition in temperature follows to set the chamber temperature at the lowest requirement limit (in this case -22°F) again for an extended period of time (8 hours). The

testing concludes with the temperature rising 10% over the lowest requirement limit (in this case -16.6°F) and kept at this temperature for a relatively shorter period of time (4 hours). The main purpose of this test is to see if the tags have any issues recording temperature accurately after prolonged exposure to extreme temperatures. Figure 11 shows the averaged RFID tag output for each of the manufacturers compared to reference sensor output. For this test, Caen and Intellex tags were set to sample every 5 minutes whereas Infratab tags were set to sample every 60 minutes.

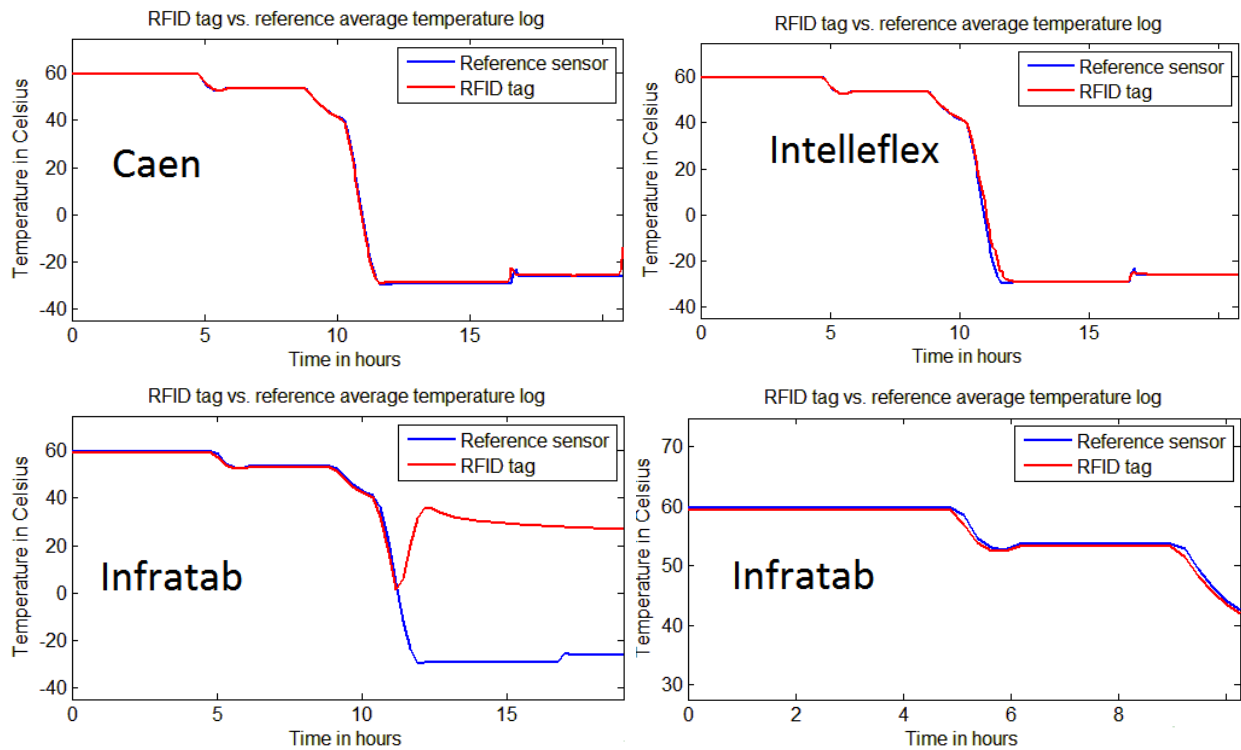

Figure 11. Averaged RFID tag – sensor output comparison for extended requirement limit testing

As seen in Figure 11 both Intellex and Caen tags were able to follow reference sensor outputs successfully throughout the experiment. While Intellex tags showed better accuracy performance at steady-state high and low temperatures, Caen tags showed better performance during temperature transitions.

In contrast, Infratab tags displayed a different behavior as previously mentioned in the 80% requirement range span testing. The shape of the red curve on the bottom right plot indicates that Infratab tags were frozen roughly around the temperature where that line break occurred. When they froze, their internal clock froze along with the sensing circuitry, and thus, when the tag came back online it started recording temperatures as if nothing happened between the times it was frozen and operational again. Since our requirements include temperatures as low as -22°F, this is a major concern for utilizing Infratab tags for this particular project. For comparison purposes, we have also attached the Infratab output plot just for the temperatures where none of the tags were frozen.

The results can be summarized as shown in Table 2.

Table 2. Results of extended limit requirement testing

	MSE	STD	Corr.
Caen	2.12°F	1.944°F	0.999688
Infratab (frozen)	2392.2°F	51.84°F	0.874171
Infratab (not frozen)	0.61°F	0.504°F	0.998352
Intellex	3.46°F	2.41°F	0.999516

1.3.3.3 Freezing Temperature Testing (Schedule C)

Since most applications utilizing temperature tags deal with the shelf life of the transported product, it is imperative to determine the freezing temperature of the tag and confirm that it is outside the requirement range. When a temperature tag freezes, it will stop recording temperature and its internal clock will not advance. Hence, when the temperature rises above freezing point, the tag will come back online and start recording the temperature but will continue the time stamps from when it was first frozen. This poses a serious problem for shelf life calculations since the estimation algorithm requires accurate temperature-time representation of the environment.

Please note that the above observation may not necessarily hold true for a product such as FSR that is not significantly affected by freezing temperatures. However, it is important to note that freezing tags are still completely unacceptable from an overall system operation point of view since it prevents complete visibility during temperature recording and might cause problems during the calculation of the shelf life algorithm.

The parameters of this type of testing are driven by the capabilities of the environmental chamber being used for the experiment. In this case, the Convicon chamber used in the project can go as low as -31°F. Hence, the low temperature point is set at this temperature and the chamber temperature is gradually lowered to this temperature from a pre-determined positive temperature (in this case room temperature of 77°F).

Please note that Infratab was not included in freezing temperature tests due to not having satisfied low temperature requirements of the project in the previous test.

For this test, both Caen and Intellex tags were set to sample every 1 minute to have a better time resolution in order to determine their freezing temperature, if any. At the end of the test, none of the 20 tags being tested had frozen. However, two of the Caen tags failed to operate as one of them stopped recording completely in the middle of the test but was able to return to normal operation after the test while the other had a complete hardware failure and was no longer operational even after the test. Figure 12 shows the averaged tag output vs. the reference sensor output. Please note that the line break in Caen plot doesn't show the tags are

frozen, instead it shows a similar phenomenon observed in the 80% requirement range span test where the tags skip sampling instants (especially at low temperatures).

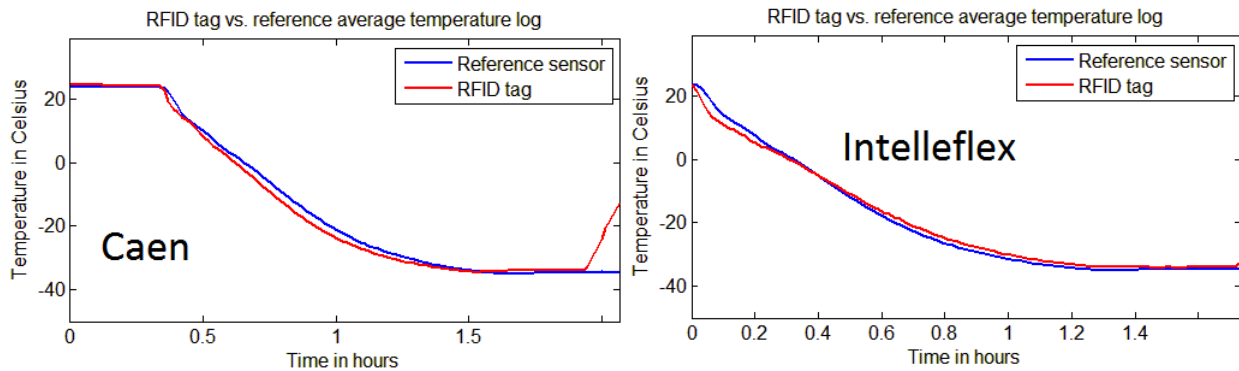

Figure 12. Averaged RFID tag – sensor output comparison for freezing temperature testing

The results can be summarized as shown in Table 3.

Table 3. Results of freezing temperature testing

	MSE	STD	Corr. Coeff.
Caen	26.64°F	6.95°F	0.98581
Intellexflex	4.356°F	2.72°F	0.998551

1.3.3.4 Two-Point Swing Testing (Schedule D)

The final temperature accuracy test in the protocol measures the accuracy and the performance of tags around two predetermined mean temperature values for an extended period of time. The results are shown in Figure 13.

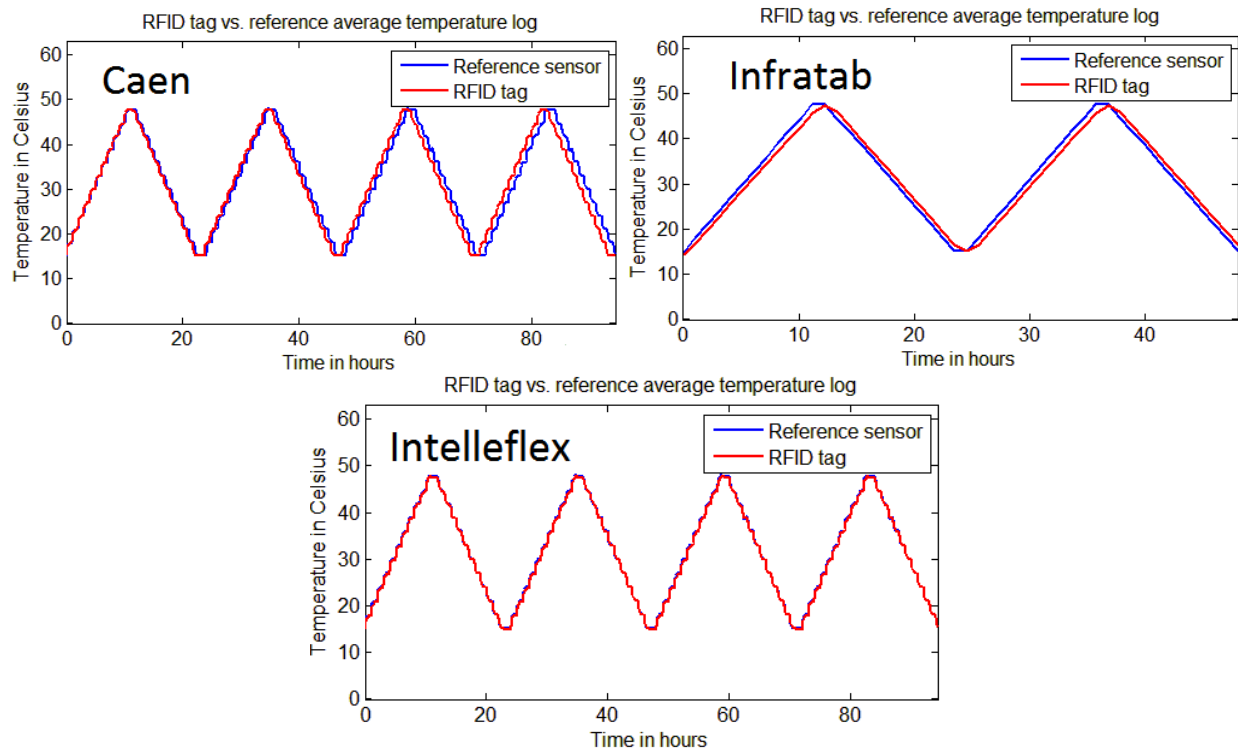

Figure 13. Averaged RFID tag – sensor output comparison for two point swing testing

The parameters for the previous tests were driven by project requirements, whereas the parameters for this test are driven by prior knowledge on the temperature distribution throughout the transportation of a typical FSR pallet shipment. In order to acquire this knowledge, the user needs to ship out temperature loggers and monitor the supply chain to determine the average maximum and average minimum temperatures. Once these two parameters are determined, the chamber temperature will swing between these two values with full 24-hour intervals to emulate the shipping lane while the reference sensors and RFID tags are recording the temperature. In order to increase the exposure time, it is recommended that multiple swings are used.

For this testing, the daily temperature summaries from a previous study by NSRDEC have been provided to Objective 1 team and from this data, the average minimum and maximum temperatures were determined to be 59°F and 118.4°F respectively. Caen and Intelleflex tags were set to sample at every 5 minutes, whereas Infratab tags at every 60 minutes due to limited memory. The overall test duration was 96 hours.

Figure 13 shows the results for three manufacturers. Even though each tag we tested was able to follow chamber temperature relatively well, Intelleflex significantly outperformed its competition with significantly lower MSE values. Caen exhibited the same type of behavior where the timing of its circuitry seemed to lead the reference sensor timing, amplified by the extended duration of the testing (96 hours). Please also note that only the first 48 hours of Infratab are displayed due to memory issues.

The results can be summarized as shown In Table 4:

Table 4. Results of two-point swing testing

	MSE	STD	Corr. Coeff.
Caen	8.73°F	3.96°F	0.976594
Infratab	3.62°F	2.56°F	0.990501
Intellex	0.09°F	0.25°F	0.999904

1.3.4 Environmental (Vibration & Temperature) Accuracy and Reliability Testing

The next and possibly most important part of the testing protocol is the environmental testing of the candidate technologies. In previous tests, the accuracy of the tags was analyzed extensively with temperature profiles with parameters based upon project requirements. In the environmental accuracy and reliability testing, the tags are also subject to transportation vibration through pre-determined random transportation modes such as truck, rail and air as well as sine vibration at different frequencies.

Contrary to temperature based accuracy testing, this setup deals with the reliability of the tags to gauge their performance under realistic transportation simulations. The unique test setup introduced at the beginning of this section can do this by vibrating the RFID tags using different power spectral density (PSD) curves to emulate transportation modes such as truck, rail and air at different temperatures. In order to accomplish this successfully, prior knowledge is needed regarding the approximate temperature distribution during transportation of the product, which can be obtained by sending out temperature loggers with a regular shipment and recording their data at the destination point. For this project we are using vibration PSDs created by American Society for Testing and Materials (ASTM) for different modes of vibration over years of accumulative knowledge (ASTM D4169 - Truck, Air, Rail for random vibration and ASTM D5112 for sine vibration). For the temperature profiles, we use the same data from the daily temperature summary study for FSR and MRE shipments performed previously by NSRDEC.

In case the total transport duration of the actual product is more than 24 hours or exceeds the continuous vibration capabilities of the test system, accelerated test methods can be applied to speed up the simulation. Similar to temperature based accuracy testing, there are different test schedules to cover different possible modes of transport; however, more test schedules can be added as well. The protocol steps are similar to temperature based accuracy testing with a few key differences.

- ⇒ Determine tag population size and record it. Similar to temperature testing, more tags will result in better statistical results.
- ⇒ Determine the number of cross-reference sensors and record it. Place cross-reference sensors outside the vibration table.
- ⇒ Initialize the tags by clearing memory and initializing the internal clock.

- ⇒ Set the temperature sampling rate.
- ⇒ Start the tags.
- ⇒ Place at least one cross reference sensor and two RFID tags from each manufacturer on chamber walls, away from the vibration table as control samples.
- ⇒ Place the remaining cross reference sensor and RFID tags on the vibration table.
- ⇒ Set the temperature schedule of the chamber to simulate shipping temperature distribution during the vibration event.
- ⇒ Run test schedules as explained below.
- ⇒ Retrieve tags from the environmental vibration chamber.
- ⇒ Stop the tags.
- ⇒ Read and record memory.
- ⇒ Process the temperature data into PC for further statistical analysis.

This protocol uses the standard way of defining a vibration profile by power spectral density (PSD) plots, which show the random possibility of having a specific acceleration at a given frequency. The controller unit of the vibration table, Lansmont 6200, allows specifying the total test duration and the corresponding vibration profile to be applied to the actuator of the table within that time. It is important to note that the profiles discussed below aim to cover the entirety of possible modes of transportation but they can and should be changed or amended depending on the transportation mode of the actual product. Correspondingly, the requirements of the application itself will decide which vibration profiles will be used in vibration based reliability testing.

For this project, we have chosen two different temperature profiles with three different transportation modes for a total of six random vibration tests as well as five different steady-state temperatures for 1-hour long sine vibration tests.

- ⇒ Temperature profile 1 – 104°F to 5°F (for truck, rail and air mode)
 - This temperature profile was chosen to include as extreme limits as possible by the operating specifications of the vibration table. It is known in the literature that electronics tend to fail under vibration more at extreme low temperatures than at regular temperatures. Hence, based on the maximum allowable temperature range dictated by the vibration table, our first profile covers all the way down to 5°F.
- ⇒ Temperature profile 2 – 59°F to 118.4°F (for truck, rail and air mode)
 - This temperature profile is based on real life knowledge of FSR/MRE shipping lane temperatures and is similar to the two points swing test explained in the previous section.
- ⇒ Steady-state temperatures of 118.4°F, 89.6°F, 59°F, 32°F, 5°F
 - A 1-hour long high intensity sine vibration test was administered at these five temperatures to gauge reliability and accuracy.

1.3.4.1 Truck Mode Vibration with 104°F to 5°F Temperature Profile

In this test, truck mode vibration with the PSD shown in Figure 14, was used along with the 104°F to 5°F temperature profile to test for overall accuracy and reliability. The overall test duration was set at 12 hours with intensified vibration PSD to emulate a full 24 hour shipment. The Caen and Intellex tags were set at 5 minute sampling rates whereas Infratab tags were set at 15 minutes.

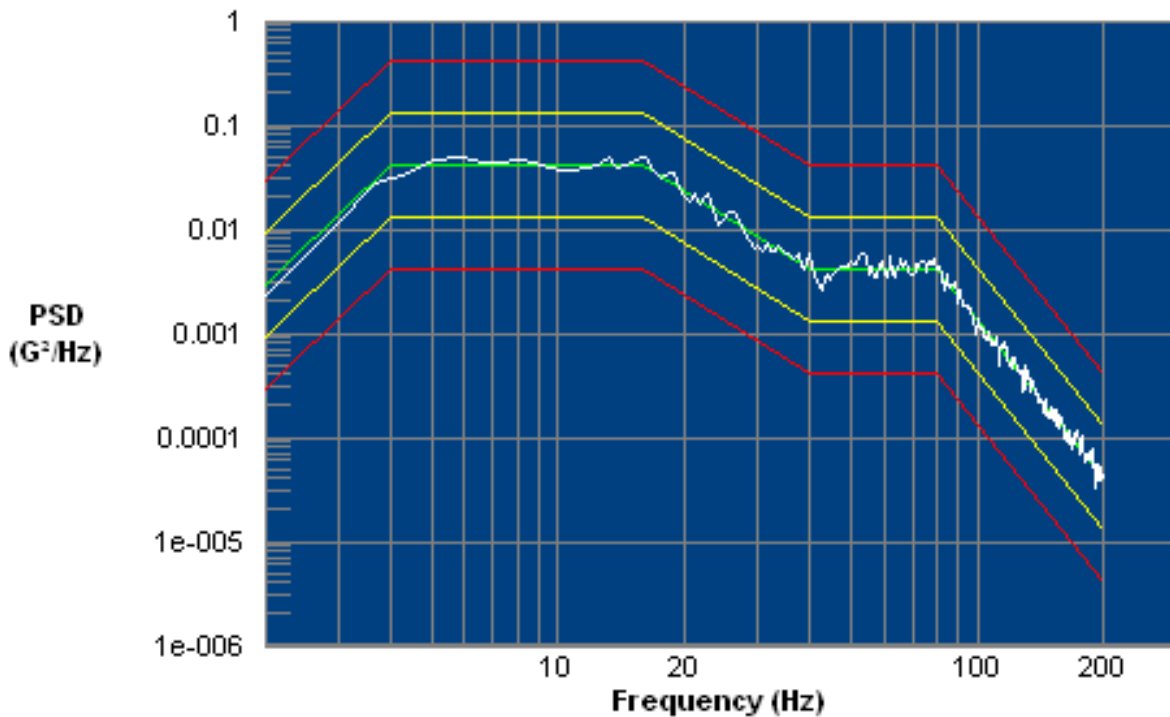

Figure 14. The power spectral density (PSD) of the vibration profile used for truck mode

Figure 15 shows the average RFID tag output for each manufacturer compared to the reference sensors. Similar to the previous tests, Infratab tags were frozen below a certain temperature. The biggest problem is the fact that each Infratab tag freezes at a different temperature as shown in Figure 16. Where the line breaks occur for each tag defines its freezing temperature. As you can see, some of the tags have higher freezing temperatures than the others. Hence, even software designed to work around this issue (assuming freezing temperatures do not damage the product) will have a difficult time accounting for different freezing temperatures.

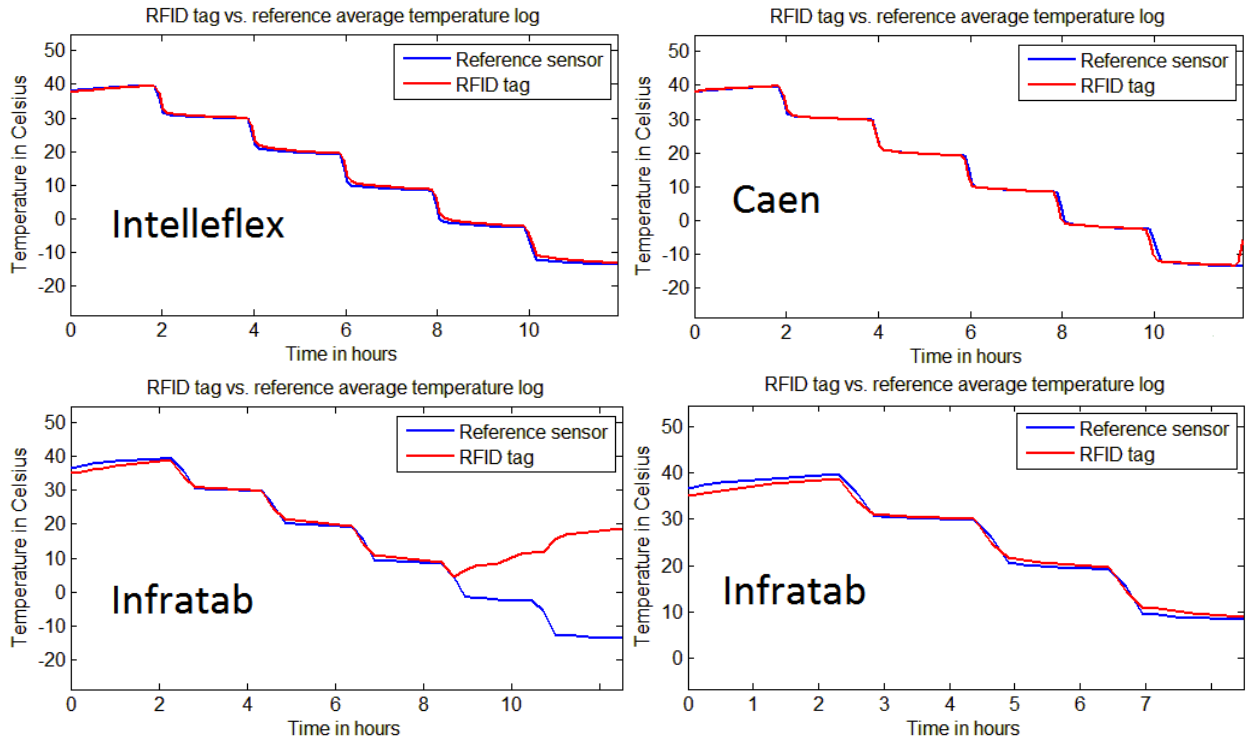

Figure 15. Averaged RFID tag – sensor output comparison for 104°F to 5°F truck mode testing

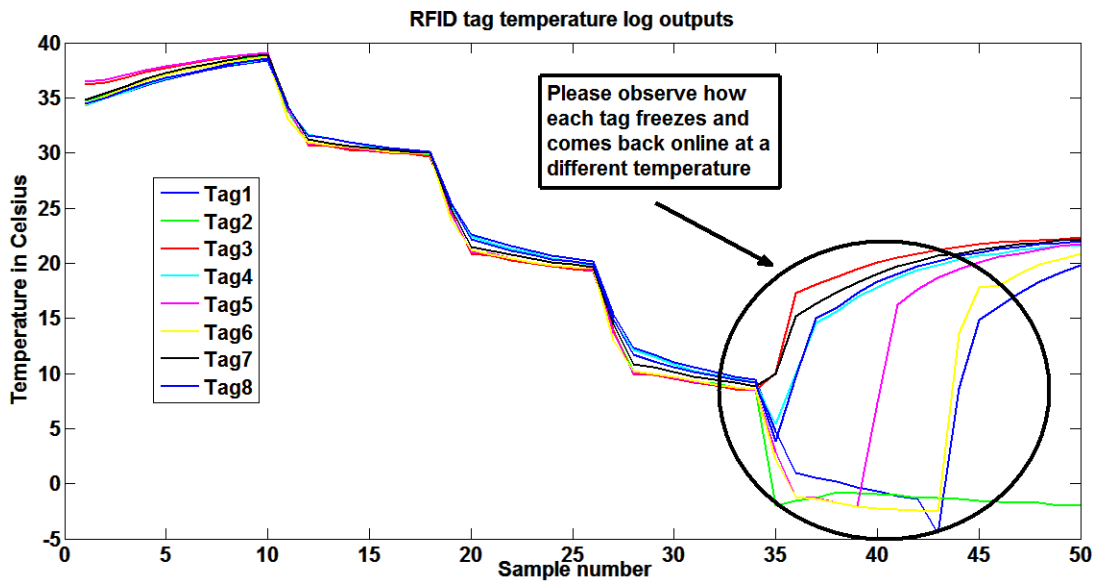

Figure 16. Freezing temperatures for Infratab tags

The results can be seen in Table 5.

Table 5. Results of truck mode vibration testing with 104°F to 5°F temperature profile

	MSE(wall)	MSE(table)	STD(wall)	STD(table)	Corr. (wall)	Corr. (table)
Caen	1.53°F	1.75°F	1.62°F	1.78°F	0.998843	0.998497
Infratab (not frozen)	0.59°F	1.98°F	1.03°F	1.91°F	0.999123	0.997908
Intellex	0.49°F	0.94°F	0.63°F	0.90°F	0.999916	0.999742

As can be observed in Table 5, for each of the tag manufacturers the accuracy of the tags diminishes slightly with vibration as the MSE values for the wall tags are smaller than the MSE values for the tags attached on the vibration table. From now on, the accuracy results of only the table tags will be tabulated unless there is a wide discrepancy with the wall tag outputs indicating a significant problem in accuracy under vibration.

1.3.4.2 Rail Mode Vibration with 104°F to 5°F Temperature Profile

In this test, rail mode vibration with the PSD shown in Figure 17 has been used along with the 104°F to 5°F temperature profile to test for overall accuracy and reliability. The overall test duration was set at 12 hours with intensified vibration PSD to emulate a full 24 hour shipment. The Caen and Intellex tags were set at 5 minute sampling rates whereas Infratab tags were set at 15 minutes.

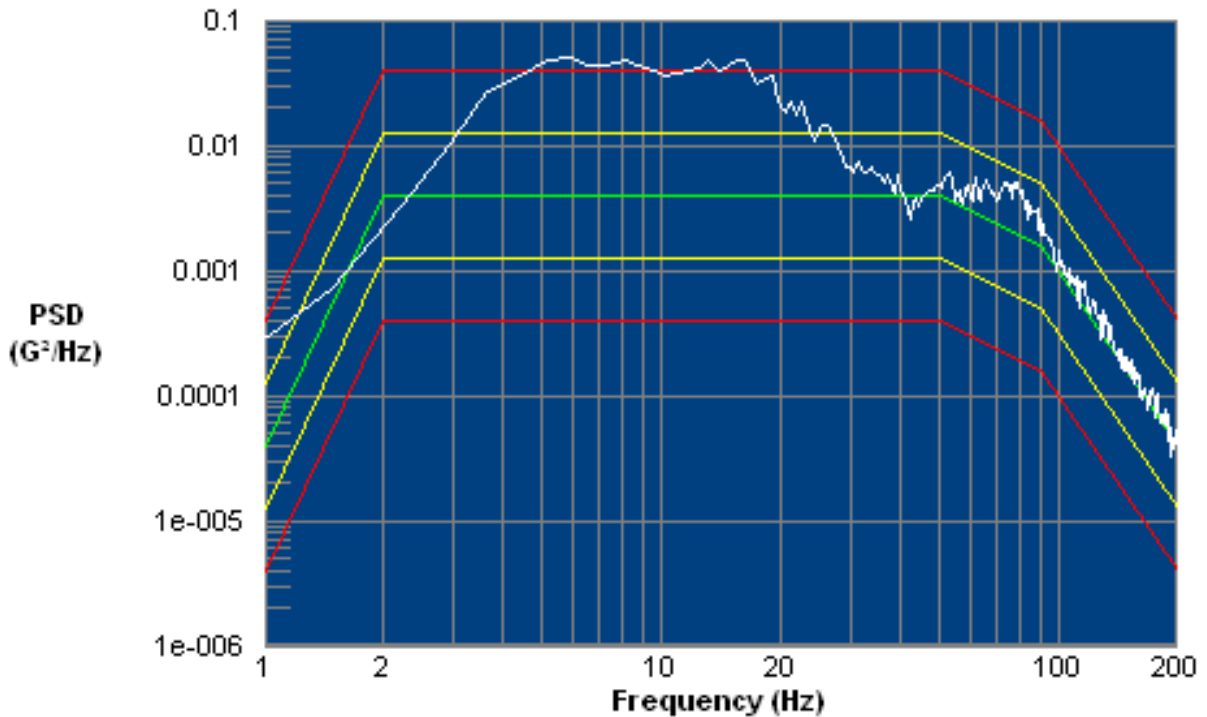

Figure 17. The power spectral density (PSD) of the vibration profile used for rail mode

Table 6 shows the statistical results of the test. Figure 18 shows the averaged RFID tag outputs along with the cross reference sensor outputs. For Infratab tags, only the temperature profile where the tags were not frozen is displayed.

Table 6. Results of rail mode vibration testing with 104°F to 5°F temperature profile

	MSE	STD	Corr.
Caen	1.66°F	1.73°F	0.998553
Infratab (non frozen)	3.74°F	2.48°F	0.928471
Intellex	2.39°F	1.66°F	0.999278

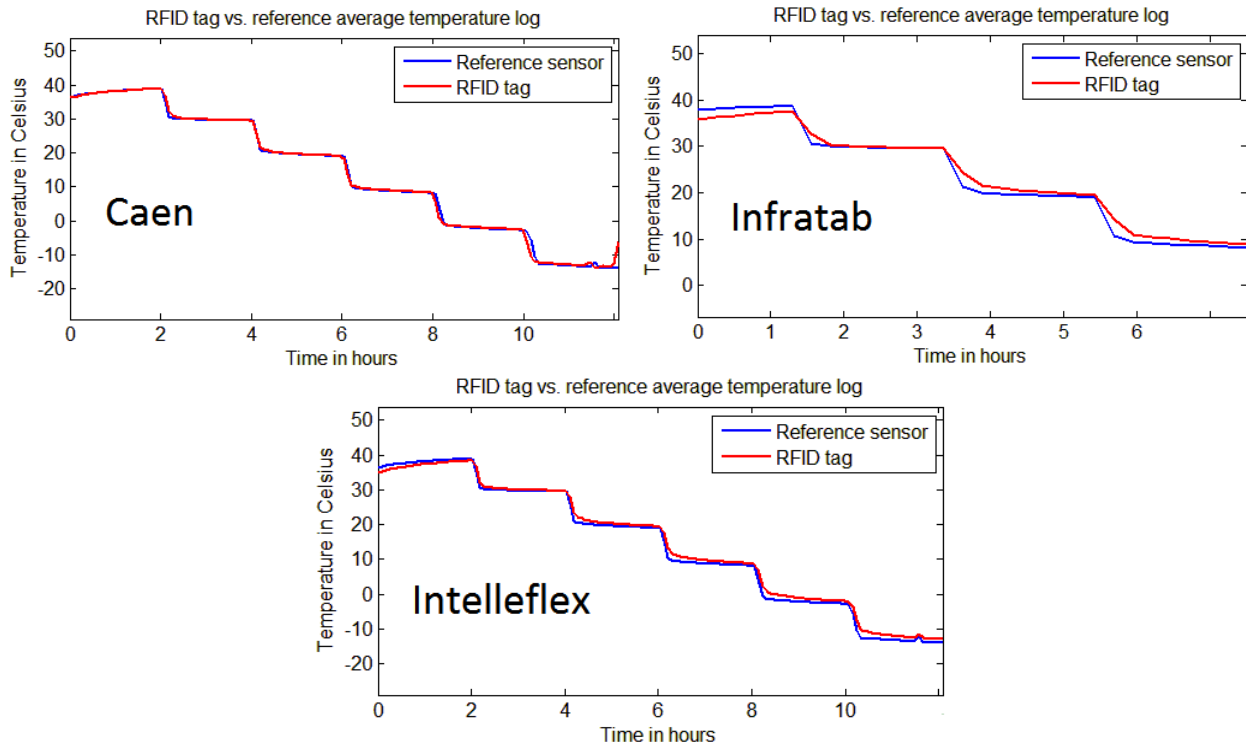

Figure 18. Averaged RFID tag – sensor output comparison for 104°F to 5°F rail mode testing

1.3.4.3 Air Mode Vibration with 104°F to 5°F Temperature Profile

In this test, air mode vibration with the PSD shown in Figure 19 has been used along with the 104°F to 5°F temperature profile to test for overall accuracy and reliability. The overall test duration was set at 12 hours with (unlike others) normal intensity PSD since air transportation typically takes no longer than 12 hours. The Caen and Intellex tags were set at 5 minute sampling rates whereas Infratab tags were set at 15 minutes.

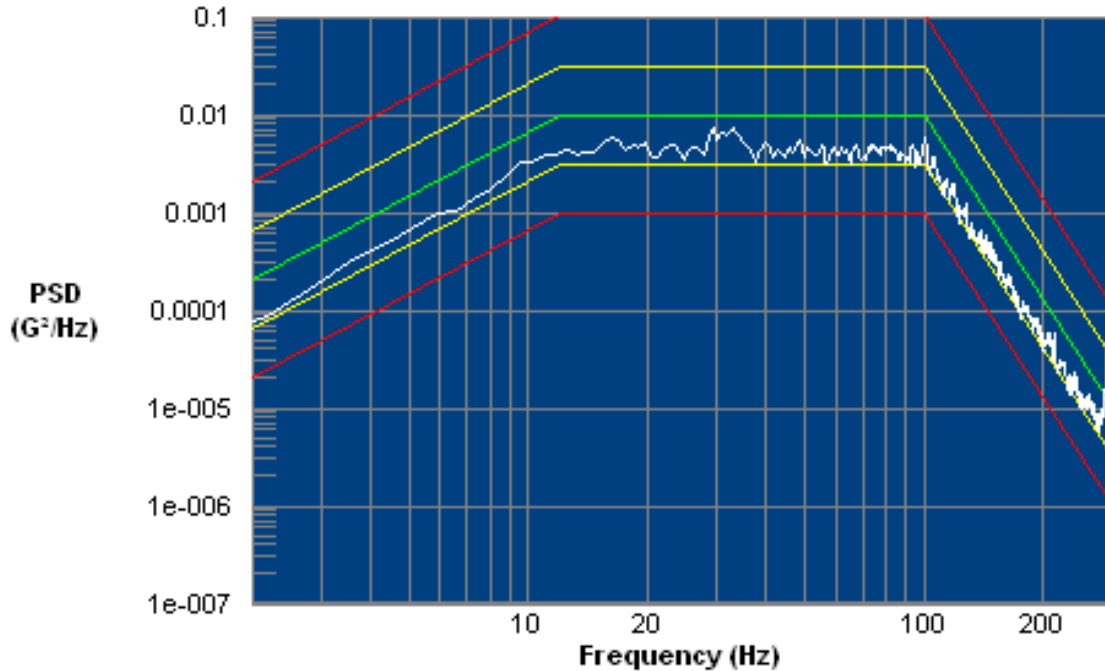

Figure 19. The power spectral density (PSD) of the vibration profile used for air mode

Figure 20 shows the averaged RFID tag outputs along with the cross reference sensor outputs. For Infratab tags, only the temperature profile where the tags were not frozen is displayed.

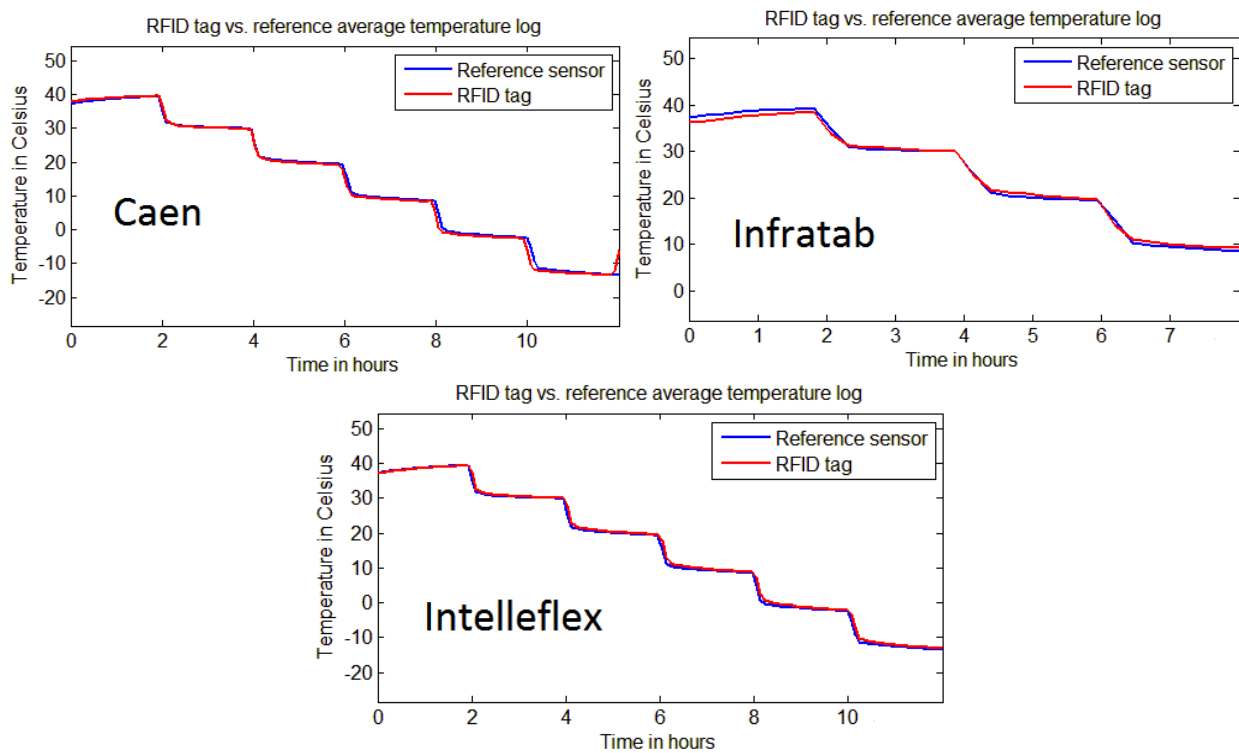

Figure 20. Averaged RFID tag – sensor output comparison for 104°F to 5°F air mode testing

The statistical results are shown in Table 7.

Table 7. Results of air mode vibration testing with 104°F to 5°F temperature profile

	MSE	STD	Corr.
Caen	2.00°F	1.84°F	0.998474
Infratab (non frozen)	0.83°F	1.24°F	0.999096
Intellexflex	0.76°F	0.90°F	0.999654

1.3.4.4 Truck Mode Vibration with 59°F to 118.4°F Temperature Profile

As previously mentioned, the same random vibration profiles of truck, rail and air have also been used with a different temperature profile, parameters of which have been set by prior knowledge on the shipping lanes of FSR/MRE by the daily temperature study performed by NSRDEC. The temperature profile is similar to the two-point swing test except it is only a half swing with intensified vibration PSD to simulate a longer shipment. Similar to the tests described above, the overall test duration was set at 12 hours with intensified vibration PSD to emulate a full 24 hour shipment. The Caen and Intellexflex tags were set at 5 minute sampling rates whereas Infratab tags were set at 15 minutes.

The results are shown in Table 8. Figure 21 shows the averaged RFID tag outputs compared to reference sensor outputs. The results are tabulated below.

Table 8. Results of truck mode vibration testing with 59°F to 118.4°F temperature profile

	MSE	STD	Corr.
Caen	0.18°F	0.54°F	0.999547
Infratab	1.51°F	0.85°F	0.999522
Intellexflex	0.07°F	0.24°F	0.999916

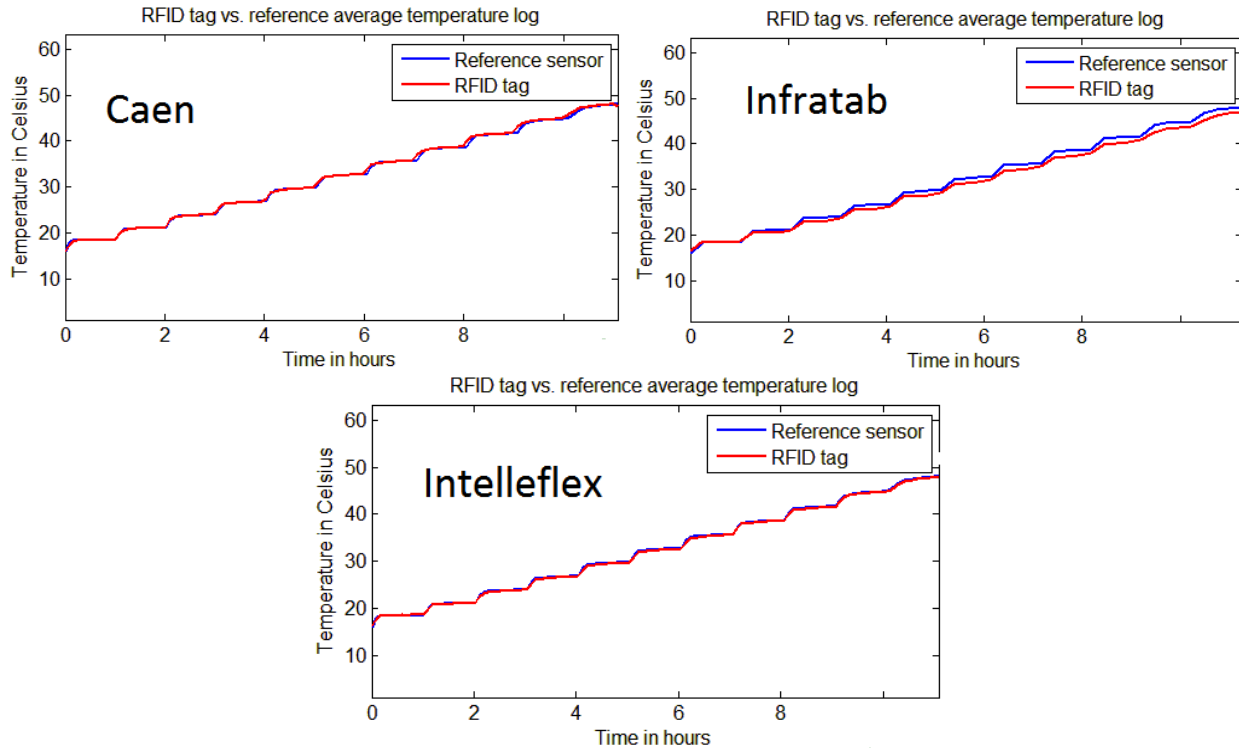

Figure 21. Averaged RFID tag – sensor output comparison for 59°F to 118.4°F truck mode testing

From this point on, for the remainder of this section, only the statistical results will be presented in table format since each temperature plot looks similar to the ones shown in Figure 21.

1.3.4.5 Rail Mode Vibration with 59°F to 118.4°F Temperature Profile

The overall test duration was set at 12 hours with intensified rail mode vibration PSD to emulate a full 24 hour shipment. The Caen and Intelleflex tags were set at 5 minute sampling rates whereas Infratab tags were set at 15 minutes. The results are shown in Table 9.

Table 9. Results of Rail Mode Vibration with 59°F to 118.4°F Temperature Profile

	MSE	STD	Corr.
Caen	0.18°F	0.57°F	0.99953
Infratab	1.46°F	0.72°F	0.999397
Intelleflex	0.02°F	0.18°F	0.999949

1.3.4.6 Air Mode Vibration with 59°F to 118.4°F Temperature Profile

The overall test duration was set at 12 hours with (unlike others) normal intensity PSD since air transportation typically takes no longer than 12 hours. The Caen and Intelleflex tags were set at 5 minute sampling rates whereas Infratab tags were set at 15 minutes. The results are shown in Table 10.

Table 10. Results of air mode vibration with 59°F to 118.4°F temperature profile

	MSE	STD	Corr.
Caen	0.14°F	0.38°F	0.999615
Infratab	1.80°F	0.94°F	0.999208
Intelleflex	0.13°F	0.32°F	0.999867

1.3.4.7 Sine Mode Vibration Tests @ 118.4°F, 89.6°F, 59°F, 32°F, and 5°F

As the last step of environmental testing, we decided to look at sine vibration at different temperatures to observe if there are any resonant frequencies for any of the tags by the three manufacturers. Different from the random vibration tests, each sine vibration test took place within 60 minutes. As shown in Figure 22, the ASTM standard of 3Hz to 100Hz sine sweep with 1 octave/minute was modified such that the vibration frequency of the table was changed from 3Hz to 100Hz with a peak acceleration level of 0.5G within 1 hour. In order to achieve this, the frequency rate of change was adjusted to 0.085 octaves / minute.

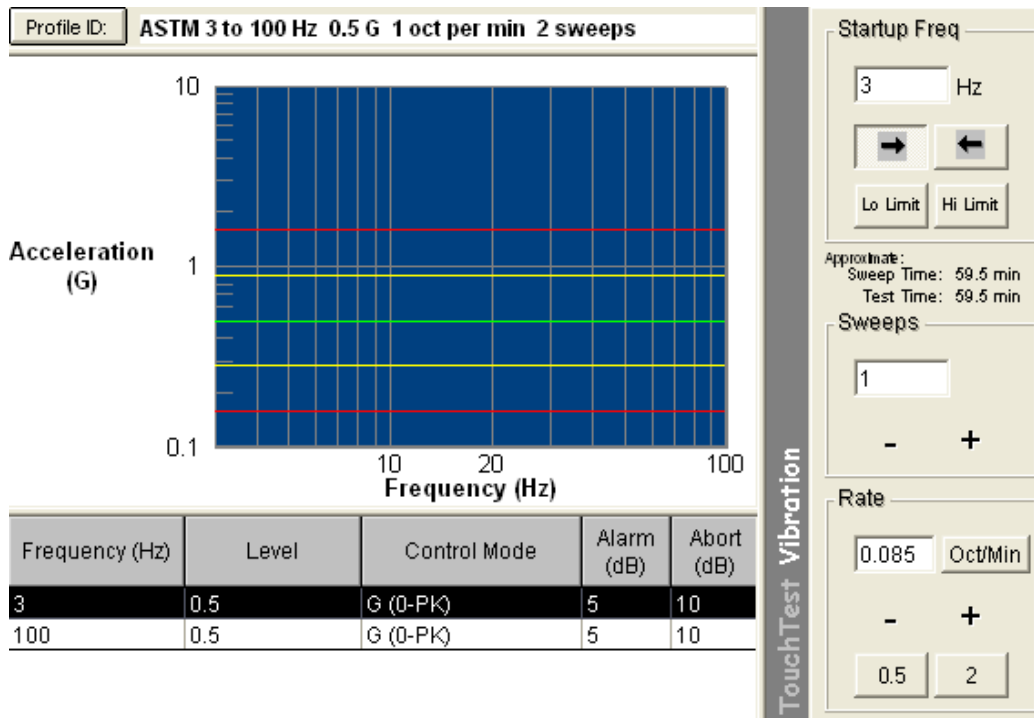

Figure 22. The settings used for sine vibration testing

Figure 23 shows what the typical averaged RFID tag outputs look like compared to reference sensors for T = 32°F.

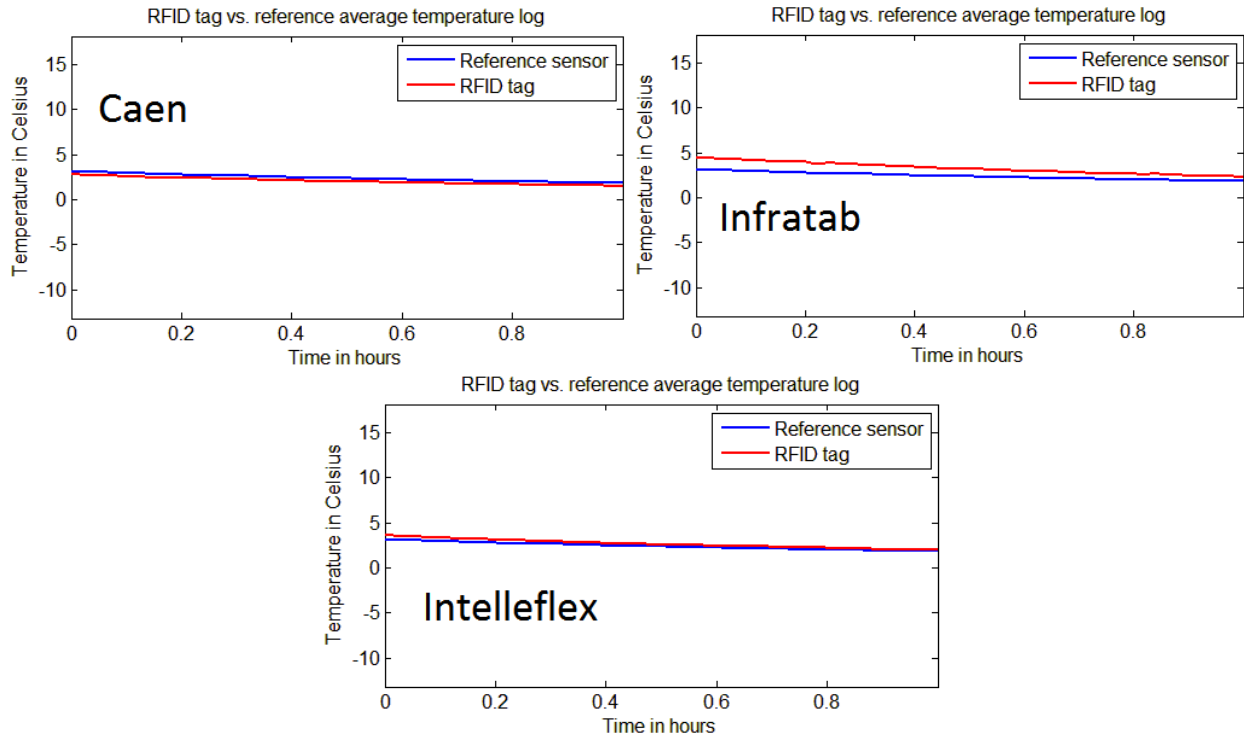

Figure 23. Averaged RFID tag – sensor output comparison for sine vibration testing @ 32°F

Since the rest of the plots for different temperatures all look alike, all of the entire data are represented statistically. The averaged statistical results are shown in Table 11.

Table 11. Results of Sine Mode Vibration Tests at 118.4°F, 89.6°F, 59°F, 32°F, and 5°F

	118.4°F		89.6°F		59°F		32°F		5°F	
	MSE	STD	MSE	STD	MSE	STD	MSE	STD	MSE	STD
Caen	0.04°F	0.02°F	0.18°F	0.05°F	0.00°F	0.00°F	0.20°F	0.07°F	0.02°F	0.07°F
Infratab	16.22°F	1.03°F	1.03°F	0.16°F	11.07°F	0.85°F	1.62°F*	0.45°F*	NA	NA
Intelleflex	0.05°F	0.04°F	0.00°F	0.04°F	0.02°F	0.04°F	0.14°F	0.14°F	0.14°F	0.04°F

There are three important things to note regarding the results presented in the above table:

- ⇒ Since the manufacturer specified temperature accuracy of Hoboware cross reference sensors themselves are +/-0.18°F, it is not mathematically possible to say one tag is better than the other as long as they are within that magnitude of error. Hence for all of the sine vibration tests at each of the five temperatures it can only be said that both Intelleflex and Caen performed similarly (statistically insignificant differences) in terms of accuracy and they both performed better than Infratab.
- ⇒ Infratab tags were not used for 5°F test due to the fact that they freeze at that temperature.
- ⇒ At 32°F, four Infratab tags failed to record any temperature information so the results in the table for those entries are denoted by *.

1.3.5 Read Range Testing for Caen and Intellex Systems

In addition to the environmental tests as defined by the protocol described in the previous section, we have also tested the range limitations of ten tags for both Caen and Intellex in a semi-controlled environment with the least amount of potential interference.

1.3.5.1 Caen Range Testing

The Caen range study was performed by the team at Georgia Tech under supervision of Dr. Gisele Bennett and Jeff Jo. For this test, the tags were placed on a wooden box approximately 1 foot tall and oriented adjacent to the pointing direction of the scanner. The reader (Workabout Pro 2 handheld) was configured to use the maximum power setting of 500mW. We then marked off measurements of 3 and 6 feet away from where the tag was positioned to indicate where we would need to hold the reader for each trial. Initially we also included measurements of 9 and 12 feet, but as the trials continued, we noticed that the reader was unable to successfully read at those distances so they were omitted from the results. The reader was held by the user close to the body in a natural way allowing the user to read the information and never veering from this position during any of the trials.

Our tests consisted of distance, operation, and orientation attributes where each operation was attempted five times per orientation per distance. Given ten tags, two distances, three operations, two orientations, and five trials we collected 600 data points in total. The operations consisted of scanning for tags, downloading tag data, and starting and stopping the tag's logging session. As shown in Figure 24 we decided to orient the tag with the "R" located on the tag facing towards the user and facing away from the user to see if this had any effect on the range.



Figure 24. Tag orientations with respect to the handheld reader

The table below displays the raw data from the tests. Each cell contains a number between 0 and 5 corresponding to the number of successful communication attempts that occurred for the stated operation at the stated distance with the stated orientation on the subject tag. The accuracies are then calculated for each operation/distance/orientation, and then overall

accuracies are computed for each distance/orientation over all operations, and finally the accuracies for each distance over all operations and orientations. The results are shown in Table 12.

Table 12. Results of Caen range testing

	Scan				Download				Start/Stop			
	3ft		6ft		3ft		6ft		3ft		6ft	
Tag ID	Toward	Away	Toward	Away	Toward	Away	Toward	Away	Toward	Away	Toward	Away
FF44	5	5	5	5	5	5	5	3	5	5	1	4
0001	5	5	5	5	5	5	5	5	5	5	5	5
0014	4	5	5	4	5	5	5	5	5	5	4	5
0059	5	5	5	5	5	5	5	4	5	5	3	5
0023	5	5	5	5	5	5	0	2	5	5	5	2
0035	5	5	5	5	5	5	5	5	5	5	2	1
004F	5	5	4	3	5	5	3	5	5	5	5	5
0027	5	5	1	2	5	5	0	0	5	5	0	0
006C	5	5	5	5	5	5	5	5	5	5	5	5
002B	5	5	5	5	5	5	3	0	5	5	2	0
Accuracy	98%	100%	90.00%	88%	100%	100%	72%	68%	100%	100%	64%	64%
	3ft Toward Accuracy		99.33%		6ft Toward Accuracy		75.33%		Total 3ft Accuracy		99.67%	
	3ft Away Accuracy		100%		6ft Away Accuracy		73.33%		Total 6ft Accuracy		74.33%	

As observed from the above table, the overall accuracy drops roughly 25% as the handheld reader is moved from 3 ft to 6 ft. Some tags (such as 0027) have significantly worse performance than the others and affect the overall performance results. Another conclusion is that configuration of the tag (starting, stopping, etc.) requires writing to tag memory and is more range dependant than reading the tag memory such as scanning and downloading.

1.3.5.2 Intellex Range Testing

For the Intellex testing we did a similar study but instead of a wooden box, we have used an actual pallet of FSR and attached the tags on the side of the pallet. Motorola MC9090 handheld uses an RFID antenna that is linearly polarized and has approximately a 70-degree cone measured from the nose of the device. In order to ensure correct placement of the tag, the tag was placed parallel (front facing the reader) and within the 70-degree read field of the handheld antenna. We have used the same output power level of 0.5mW with the Motorola MC9090 handheld equipped with compact Intellex module reader. Initially, we started with 3 feet, 6 feet and 9 feet distances from the pallet but since we were able to get 100% accuracy with each testing, we decided to extend the distance to 12 and 24 feet. We then marked distances of 12 feet and 24 feet away from the pallet and ran the same tests (of read/write/configure) with the ten Intellex tags. The results are shown in Table 13.

Table 13. Results of Intellex range testing

	Scan		Download		Start/Stop	
	12ft	24ft	12ft	24ft	12ft	24ft
Tag ID						
7601	5	5	5	5	5	4
7602	5	5	5	4	5	3
7603	5	5	5	5	5	5
7604	5	5	5	5	5	5
7605	5	5	5	4	5	4
7606	5	5	5	4	5	4
7607	5	5	5	5	5	5
7608	5	5	5	5	5	5
7609	5	5	5	4	5	4
76010	5	5	5	5	5	4
Accuracy	100%	100%	100%	92%	100%	86%
12ft Total Accuracy	100%		24ft Total Accuracy	92.66%		

The results in the table indicate that even though there still is a performance drop of roughly 10% going from 12 feet to 24 feet, class 3 communication protocol coupled with a patented antenna design helps Intellex tags outshine their competition in terms of minimal interference read range. Even though the RFID chip-reader air interface is similar between class 1 and 3 protocols, class 3 protocol defines a more efficient way of communicating the data stored in the memory of the tag (in this case, the temperature log) which results in faster communications, less bit error failure over the same distance and thus extended range. Please note that in an actual use case setting with other RF sources in the environment these results will be affected; however, considering the original project requirement of 6 to 10 feet, it is safe to say Intellex tags will still operate successfully.

1.3.6 Context Based Temperature Accuracy Metric

One of the novel contributions of the proposed protocol is the introduction of a smart and context based accuracy metric that goes beyond the standard definition of mean error for an objective performance measure to choose the best tag for applications based on shelf life estimation.

Typically, when a temperature tag is used to track the temperature of a product, the most important characteristic that is being monitored is the remaining shelf life. The previous section discussed the proposed testing protocol for the general accuracy and reliability of the tags to be used for recording the temperature. In this section, we will describe how the results obtained from the previous tests can be combined in an intelligent way to create a quantitative and definitive measure that depends on the characteristic shelf life of the product in consideration.

1.3.7 Shelf Life Estimation

In the literature there are many different algorithms for accurate shelf life estimation; however, the discussion of these algorithms is beyond the scope of this report. For illustrative purposes, we will use a simpler, exponential approach called the Arrhenius model, which is defined by the following equation:

$$t_f = A \exp\left\{\frac{\Delta H}{kT}\right\} \quad (1)$$

where t_f is the time to failure, or the remaining shelf life; A is a parametric constant that depends on the product; k is the Boltzmann's constant, which equals to 8.617×10^{-5} eV/K; T is the temperature in Kelvin at which the failure process takes place; and finally ΔH is the activation energy, which is the most critical parameter in the model. The activation energy depends entirely on the chemical specifications of the product. Finding the parameters of the model requires experimental studies on the product, but for argument's sake, we will assign random numbers to A and ΔH such that our sample imaginary product has a shelf life as depicted in Figure 25.

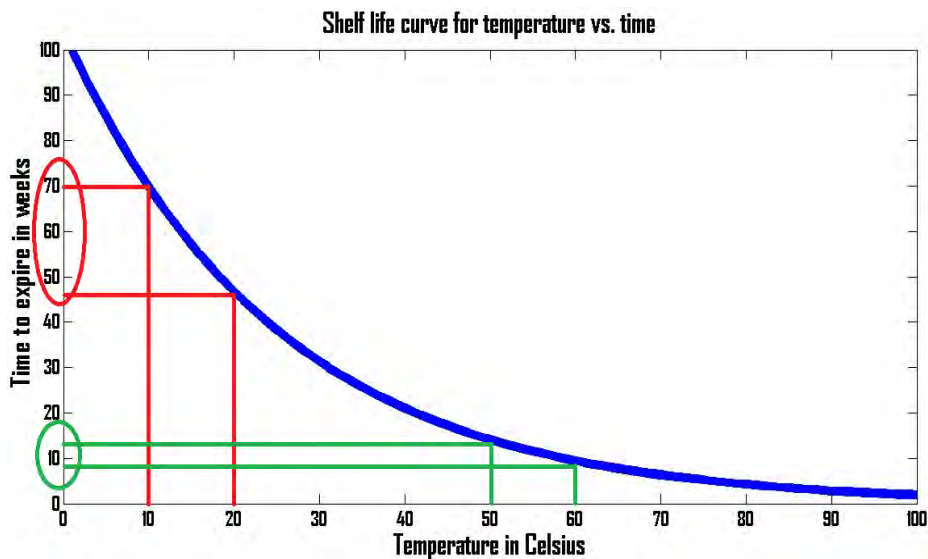

Figure 25. A typical shelf life plot for an imaginary product

Figure 25 shows that the shelf life curve is exponential, i.e., the rate of change in the shelf life of the product is lesser at higher temperatures. For instance, as shown in Figure 25 the difference in shelf life between 50°F and 68°F is greater than the difference between 122°F and 140°F. This tells us that if a specific tag has more error between 50°F and 68° it would affect the performance of the shelf life estimation algorithm worse than a tag with more error in the 122°F and 140°F range, simply because the shelf life curve is more flat within the latter range. This observation tells us that the slope (derivative) of this curve should affect the decision of the most accurate tag beyond simple mean error calculations. In other words, the mean square error (MSE) for a sensor (as used in the environmental testing described in earlier sections) is defined as follows:

$$MSE = \frac{1}{N} \sum_i (T_s(i) - T_r(i))^2 \quad (2)$$

where $T_s(i)$ and $T_r(i)$ are the recorded temperatures by the tag sensor and the reference sensor at the i^{th} sampling instant. The total error across all sampling instants is then averaged over the test duration with a total number of N sampling instants. Even though this provides a rough (and most commonly used) guideline for accuracy comparison between the tags, it does not provide a smart and context based decision based on the specifics of the product and its shelf life.

Instead, we propose the following novel solution:

$$CBA = \frac{1}{N} \sum_i f(T_r(i))(T_s(i) - T_r(i))^2 \quad (3)$$

where CBA stands for context-based accuracy and $f(T_r(i))$ is a function of temperature that takes the current reference temperature as input and returns a constant multiplier derived from the shelf life curve of the product. Since one needs to amplify the effect of the sensor error at temperatures around which shelf life changes rapidly, $f(T)$ can be chosen as the derivative of the Arrhenius curve. Thus, the novel CBA metric is defined by the following final equation:

$$CBA = \frac{1}{N} \sum_i \text{abs}(t'_f(T_r(i)))(T_s(i) - T_r(i))^2 \quad (4)$$

where t_f stands for the derivative of the time to failure function as defined by the Arrhenius equation in the above section. The absolute value of this function is required to find the real magnitude of change at a specific temperature.

Once CBA is calculated for each tag being tested, the population of tags that have the lowest CBA values will provide the best solution for that specific application. The same logic can be applied to other statistical measures such as the standard deviation to calculate the deviation around CBA instead of mean error.

It is crucial to note that, even with the developed CBA metric, all statistical analysis presented in this report uses the standard performance metrics such as mean square error (MSE). The reason for this is the fact that the parametric fine tuning of FSR's shelf life model will continue in Phase II of this project through Q4 of 2011. As more results from 80°F become available, the true accuracy improvement of using CBA over MSE will become more evident and all the statistical analysis concerning temperature accuracy will use CBA instead of MSE in Phase II.

1.4 Estimating the Inside Temperature of an FSR Pallet from the Recorded Environmental Temperature

Temperature tracking of perishable products such as fresh produce or temperature sensitive pharmaceutical drugs during their transportation has been vital to ensure the quality degradation remains acceptable when the items reach their end destination. RFID enabled

temperature loggers take this to the next level by adding the capability of wireless data transfer to remotely monitor the temperature inside a shipping container. Such information would pave the way for intelligent distribution practices such as first-expired-first-out (FEFO) instead of the more commonly used first-in-first-out (FIFO) based on the differences in the temperature profiles witnessed during transportation of individual shipments.

However, due to the dynamics of heating/cooling cycles, it is well known that the temperatures taken in close proximity to the products may be different than the temperatures measured inside the shipping container itself. For instance, the temperature inside the container can change more rapidly than the temperature inside a pallet of tightly packed food products. In some cases this might be helpful, such as when the temperature inside the pallet is low and the temperature inside the container increases rapidly. In such a scenario, it will take longer for the pallet temperature to rise to the level of container temperature, which might have a positive impact on the remaining shelf life. However, in the opposite case, even when the temperature inside the container cools down, it will take longer for the pallet temperature to come down as well and will negatively affect the remaining shelf life. In summary, it is crucial to measure the temperature inside the pallet rather than the container to have a more accurate representation of the remaining shelf life.

The limitations of RFID technology, such as the reduced performance near metals and liquids, might prevent placing RFID temperature tags inside pallets with significant metal and liquid content. One example of this would be FSRs as they are shipped and stored in tightly packed pallets where the shipping or storing temperatures can exceed 150-160°F, which results in dramatically reduced shelf life. Since this project deals with the estimation of remaining shelf life based on the temperatures measured by RFID temperature loggers during shipment and storage, in order to best monitor the temperature inside the pallet, the trivial solution is to place the temperature tags inside for more accurate measurement. However, this causes serious problems during the interrogation of these tags due to all the metal and liquid content of the rations inside the pallet. Hence, the tags are placed outside the pallet, measuring only the temperature inside the container. One can use this information as an approximation to the actual temperature inside the pallet and calculate remaining shelf life based on this data; however, there is a more accurate way of estimating the temperature in close proximity to the products inside the pallet.

This study was performed to find the correlation between the temperatures inside and outside the pallet during heating/cooling of the environment. Eight different experiments were performed where one temperature sensor was placed outside the FSR pallet and two sensors inside the pallet, labeled as *20-alpha* and *36-prime*. The labeling of the points inside the pallet simply replicates the names of the terminals the two thermocouples were connected to and has no specific meaning. Based on the heating/cooling intervals, the tests can be divided as follows: 6 hours/6 hours, 9 hours/15 hours, 8 hours/8 hours, 18 hours/18 hours, 24 hours/24 hours, 2 days/2 days, 3 days/3 days and 4 days/4 days. The results can be seen in Figures 26 and 27.

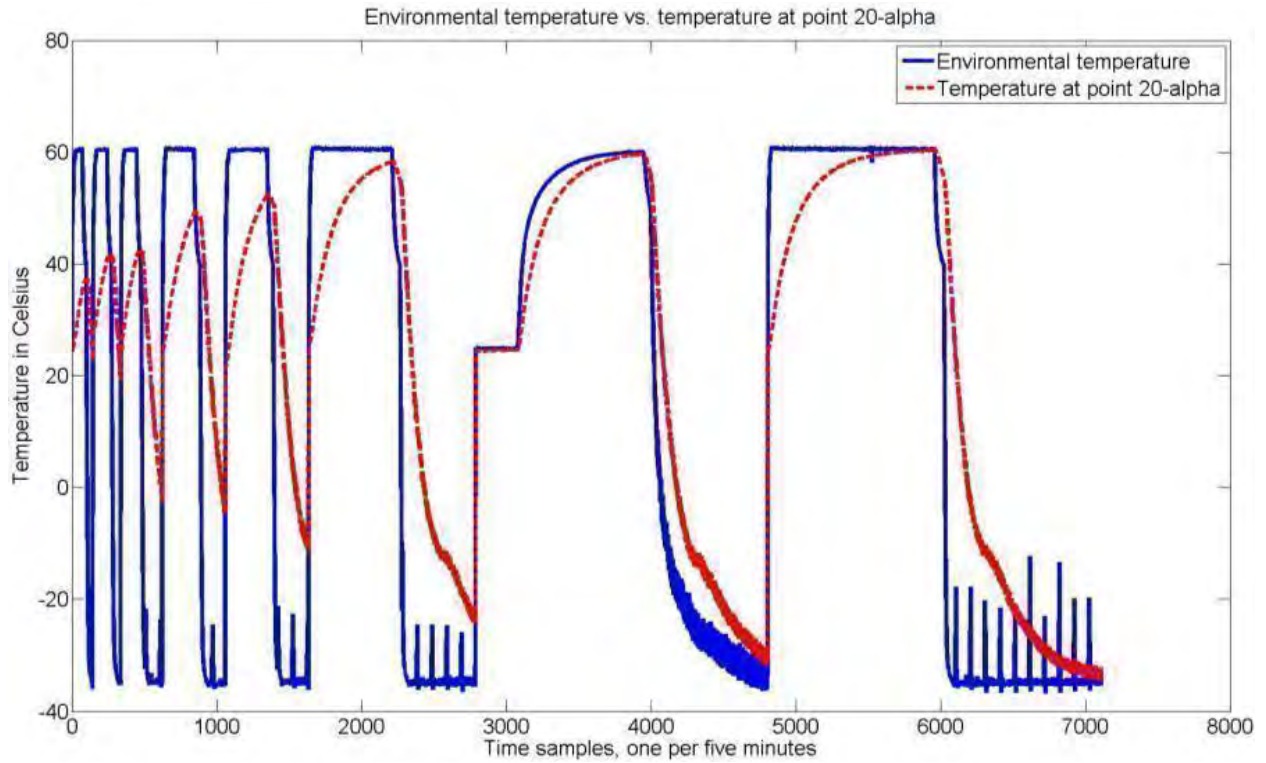

Figure 26. How the temperature inside the pallet at point labeled 20-alpha changes with the temperature outside the pallet

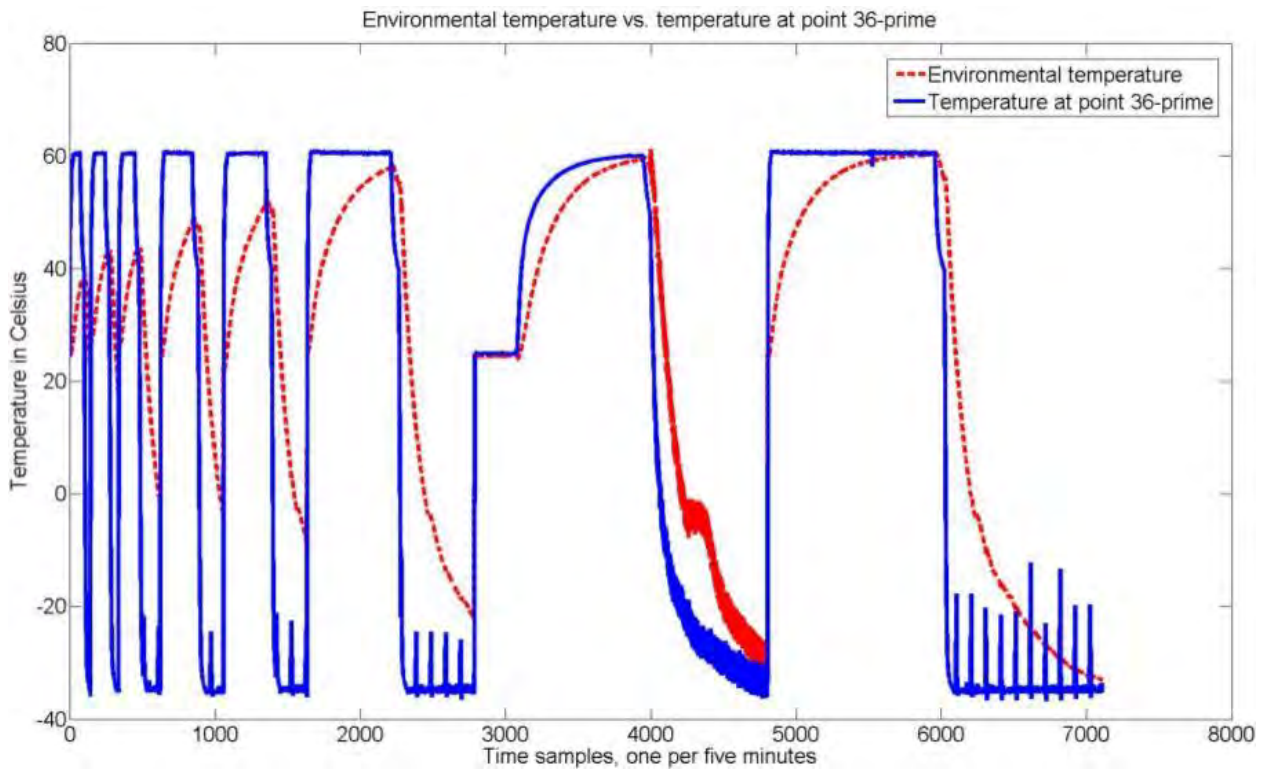

Figure 27. How the temperature inside the pallet at point labeled 36-prime changes with the temperature outside the pallet

Figure 26 shows a concatenated plot for the measured temperature levels inside and outside the rations pallet during the entire study for the point labeled 20-alpha inside the pallet. Similarly, Figure 27 shows the same plot for the point labeled 36-prime. As expected, the temperatures inside the pallet show a capacitor effect to rapidly changing temperature by slow heating/cooling cycles. In other words, the temperatures rise and decay with a time constant that can be determined from these eight experiments and can subsequently be modeled to estimate the temperature inside the pallet given the environmental temperature.

In order to better explain this phenomenon, let's take a look at a strikingly similar analogy where the environmental temperature is modeled by the potential difference between the terminals of a voltage source and the pallet temperature is modeled by the potential difference between the terminals of a capacitor as shown in the electronic circuit of Figure 28.

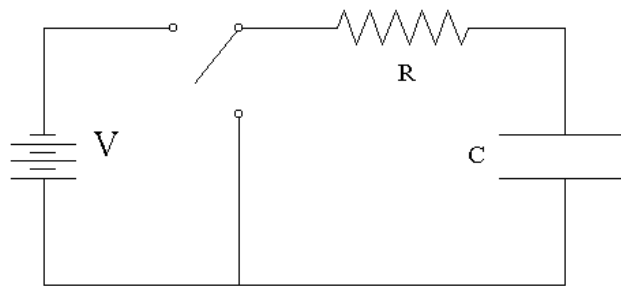

Figure 28. A typical resistor-capacitor circuit to simulate the behavior of the pallet temperature in the presence of changing environmental temperature

In this figure, V represents the environmental temperature and V_c represents the pallet temperature. The relation between the two temperatures can be explained by the following equation:

$$V_c = V_c^{initial} + (V - V_c^{initial}) \left(1 - e^{-\frac{t}{RC}}\right) \quad (5)$$

where $V_c^{initial}$ is the initial pallet temperature, R is the resistance of the resistor and C is the capacitance of the capacitor. In other words, the pallet temperature will rise or fall with a speed determined by the time constant (RC) and the difference between the temperature of the pallet and the environmental temperature. The bigger the difference the faster temperature will change inside the pallet.

In order to find the time constant empirically, one has to change the potential V and observe how the potential V_c changes with time. Both Figure 26 and Figure 27 provide enough information on how to find the time constant for both rising and falling temperatures.

If we rearrange the terms in the above equation to find τ (RC), we arrive at the following equation:

$$\tau = \frac{-t}{\ln \left(\frac{V - V_c}{V - V_c^{initial}}\right)} \quad (6)$$

Hence, if one knows the temperature inside the pallet at a given time, t , the initial temperature inside the pallet, and the environmental temperature, it becomes trivial to calculate the time constant. Unlike the electronic circuit described above, it is possible to have a different time constant for heating and cooling cycles and the way the experiments are designed will allow for separate calculation of the two.

Let's take a look at the last experiment to calculate τ_{rising} for 20-alpha point. In this experiment, the average environmental temperature sits at 60.5°C. If we define $t = 0$ as the time the pallet temperature started to increase from 24.6°C, we can then choose a second temperature point-time pair to calculate the time constant. For this example, at $t = 76$ hours the pallet temperature reaches 60°C, and this point will be used in the calculations below where T represents temperature whereas t represents time.

$$T_{\text{pallet}}(t = 0) = 24.6C$$

$$T_{\text{environmental}} = 60.5C$$

$$T_{\text{pallet}}(t = 76 \text{ hours}) = 60C \quad (7)$$

Thus;

$$\tau_{\text{rising}} = \frac{-76}{\ln\left(\frac{60.5-60}{60.5-24.6}\right)} = 17.8 \text{ hours}$$

Similarly, to find τ_{falling} , one only need define two time-temperature points where the pallet temperature slowly approaches the environmental temperature.

$$T_{\text{pallet}}(t = 0) = 60.5C$$

$$T_{\text{environmental}} = -35C \quad (8)$$

$$T_{\text{pallet}}(t = 67.5 \text{ hours}) = -33C$$

$$\tau_{\text{falling}} = \frac{-67.5}{\ln\left(\frac{-35-(-33)}{-35-60.5}\right)} = 17.5 \text{ hours}$$

The fact that the falling time constant is higher shows that the pallet cools down faster than it heats up. Based on these time constants, estimating the temperature inside the pallet can be modeled by the following two equations:

If $T_{\text{environmental}} > (T - 1)_{\text{pallet}}$, then...

$$T_{\text{pallet}} = (T - 1)_{\text{pallet}} + (T_{\text{environmental}} - (T - 1)_{\text{pallet}}) \left(1 - e^{\frac{-t}{\tau_{\text{rising}}}}\right) \quad (9)$$

If $T_{\text{environmental}} < (T - 1)_{\text{pallet}}$, then...

$$T_{\text{pallet}} = (T - 1)_{\text{pallet}} + (T_{\text{environmental}} - (T - 1)_{\text{pallet}}) \left(1 - e^{\frac{-t}{\tau_{\text{falling}}}}\right)$$

where T_{pallet} is the current estimated pallet temperature and $(T-1)_{\text{pallet}}$ denotes the previously estimated temperature sample.

Remember that this model is only an approximation of the actual temperature inside the pallet where actually measuring this temperature is impossible. In order to gauge the performance of this model, let us compare the model output with the actual measured temperature inside the pallet. Figures 29 and 30 show the estimated pallet temperature against the actual pallet temperature measured by the sensor for point 20-alpha and point 36-prime, respectively. As clearly observed from these figures, the estimated temperature is much closer to the pallet temperature than the environmental temperature and thus would be a much better candidate to be the temperature profile used in shelf life calculations.

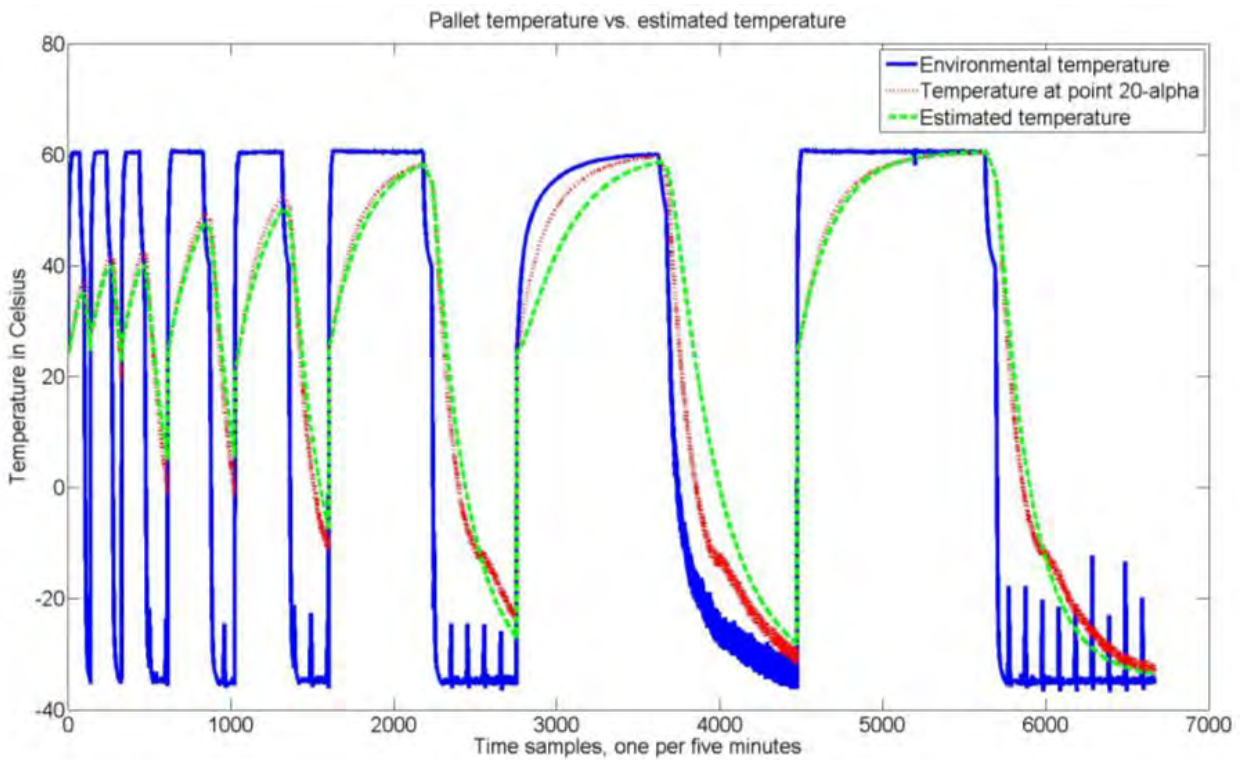

Figure 29. Comparison of environmental temperature, measured pallet temperature and the estimated pallet temperature for point 20-alpha

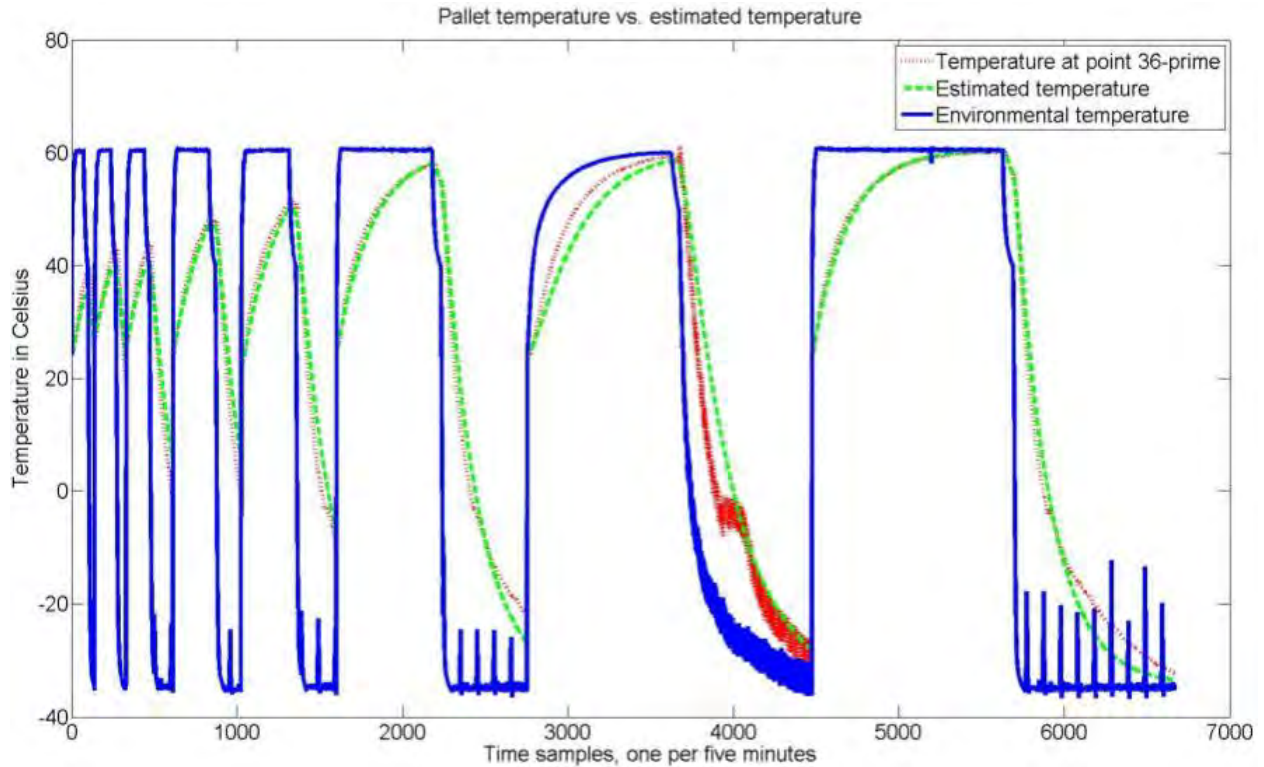

Figure 30. Comparison of environmental temperature, measured pallet temperature and the estimated pallet temperature for point 36-prime

In terms of numerical evaluation, the absolute mean error and standard deviation between the environmental temperature and the pallet temperature are as follows:

$$e_{environmental-pallet} = 17.05C$$

$$\sigma_{environmental-pallet} = 23.6C$$

In contrast, the mean error and standard deviation between the estimated temperature and the pallet temperature are much lower.

$$e_{pallet-estimated} = 3.4C$$

$$\sigma_{pallet-estimated} = 5.4C$$

Even though these calculations were performed for the point alpha-20, it's similar for the other point prime-36 as well.

To summarize, in the aforementioned application where one needs to estimate the shelf life of FSRs based on a tag attached outside the pallet, it is significantly better to estimate the pallet temperature using this model and then use the estimated temperature to calculate the remaining shelf life for much more accurate results.

It is true that each different pallet configuration would require a new thermal study to properly determine the algorithm parameters. In addition, the outside temperatures can sometimes be a better indication of the shelf life for cases with at least one side exposed. However, this can be resolved by choosing the estimation points more carefully in the thermal study. Instead of

using just two points in the pallet (which was initially chosen for a proof-of-concept for this type of estimation problem) one can place the sensors at different locations to comprehensively represent the pallet or even an entire container, such as on the side of the cases within the plastic wrap or on the cases closer to the top of the container, which would be exposed to higher temperature changes than observed by the tag.

Finally, this model was developed towards the end of the first phase of the project. A simple capacitive model, though shown to be quite effective, can be outperformed by more complex estimation models such as neural network or time series estimations. In Phase II of the project, we will explore these possibilities and more importantly integrate this type of temperature estimation inside the shelf-life model for a combined software approach.

1.5 General Information and System Overview for Caen System

The software application for the Caen system runs on a Windows Mobile device, specifically a Psion Teklogix Workabout Pro 2 (Figure 31) handheld scanner with an attached CAEN A528 RFID reader. The application then uses the CAEN A538 RFID reader to connect to the CAEN A927Z RFID temperature tags to download information and display that information to the user for analysis and as inputs into the Shelf-Life Algorithm. For the detailed technical datasheet of the handheld reader and the tags please refer to Appendix B.



Figure 31. Psion Workabout Pro 2 Handheld Reader

The biggest problem encountered in developing the software for the CAEN tags was the necessity to have access to the low level reader protocol of the handheld system (LLRP). LLRP is used to define several system parameters such as the bit rate or the Miller coefficient to ensure communication between the tag and the reader. CAEN tags (Figure 32), different from most of the other typical Class 1 Gen 2 tags, use a lower bit rate, and the default RFID reader that comes with the Motorola MC9090 handheld does not allow the user to modify the LLRP parameters of the reader. Hence, we had to do a market search and find a handheld with an integrated RFID reader that either automatically satisfies the LLRP requirements of the CAEN tags or allows the user to modify the parameters. In the end, we decided on the Psion Teklogix Workabout Pro 2 handheld scanner, since the RFID reader module integrated in this handheld has the required air interface communication protocol and LLRP parameters to communicate with the CAEN temperature tags.

Another difficulty we faced during the software development was when we tried to access the memory locations of the tag that are supposed to store the temperature data. The specsheet for the tag had the wrong memory locations and thus the research team had to analyze CAEN's own demo software to extract the right information regarding memory locations.



Figure 32. A927Z Caen Temperature Tag

The system is generally used with a Windows Mobile RFID reader application connected to a supported CAEN RFID reader peripheral. The CAEN RFID tags will be placed on pallets containing perishable goods for monitoring the temperatures the goods experience during long periods of storage and while in transit. A user will use the application to begin the logging session for those goods and periodically read the temperature data, run it through the Shelf-Life Algorithm, and determine if the products are “good” or “expired”. For the CAEN system, the output of the algorithm simply displays the current pallet condition. The software development effort for the second part of the Shelf-Life Algorithm, which actually estimates the “time-to-expire” or the remaining shelf life from the current pallet condition, was completed for the Intellex system.

Due to the nature of wireless RFID transmissions, the Shelf-Life Monitor application anticipates a number of error conditions that will occur when data transmissions are interrupted. Attempts are made to mitigate these error conditions by allowing a specific number of connection timeouts to occur before the software determines a tag is no longer in readable range. These timeouts could potentially degrade the performance of the software if a tag is at the edge of the RFID communication range.

The Windows Mobile device has a power setting that forces the operating system to go into sleep mode after a specified amount of time. When this mode is activated it appears that the Windows Mobile device has turned off. To bring the operating system out of sleep mode, hold the “Enter” key at the top right of the key pad for a few seconds and the operating system will go back into the state it was in before it went into sleep mode.

The Windows Mobile device does not have a way to reset the operating system from the operating system menu options. To initiate a hard reset on the Workabout Pro, hold the blue “FN” and red “Enter” keys simultaneously and wait for the hard reset to begin (about 5 seconds). The system will then reboot and the application can be used as normal.

To start the Shelf-Life Monitor application, select the application from the Start menu on the Windows Mobile operating system. The application will power on the CAEN RFID reader and load the software taking the user to the main screen.

1.5.1 Scan for Tags

Find all temperature tags within range of the reader and display their tag identification number (tag ID) as well as their current status. The Scan button will instruct the CAEN RFID reader to probe the area for all CAEN Temperature Tags and list their tag ID along with their current status (as shown in Figure 33 and Table 14).

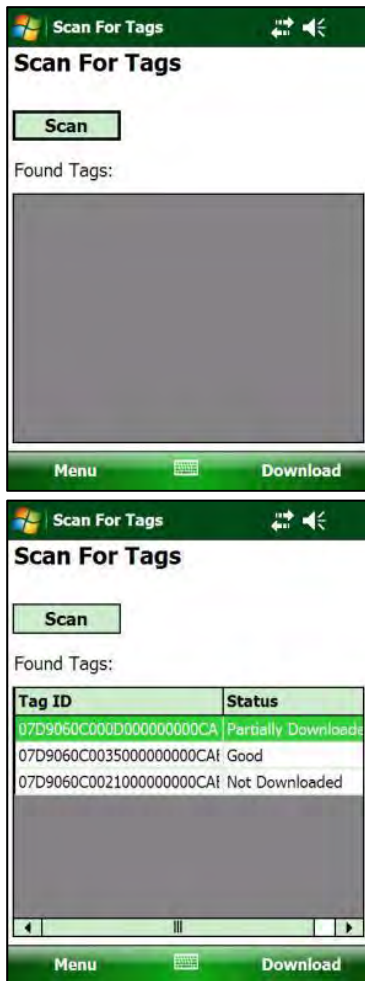

Figure 33. Scanning for Tags with Caen Reader

If the reader is unable to find any tags within range, an error message will be displayed. If the Scan button is pressed while tags are pre-existing in the “Found Tags” table, tags which have had their data downloaded will not be removed, even if they are out of range. Any tags marked as “Not Downloaded” will be removed if the most recent scan was unable to find them. This feature allows a user to analyze the data from tags that have been downloaded when they are

Table 14. Caen tag status readings and descriptions

Status	Description
Not Downloaded	The data has not yet been downloaded from the tag.
Partially Downloaded	The data has been partially downloaded from the tag due to the user cancelling the download midway through the downloading process.
Fully Downloaded	The data has been completely downloaded from the tag.
Expired	The Shelf-Life Algorithm has been run on fully downloaded data from the tag and has determined the product is expired.
Expired*	The Shelf-Life Algorithm has been run on partially downloaded data from the tag and has determined the product is expired.
Good	The Shelf-Life Algorithm has been run on fully downloaded data from the tag and has determined the product is good.
Good*	The Shelf-Life Algorithm has been run on fully downloaded data from the tag and has determined the product is good.

out of range and informs the user which tags are available for downloading based on the most recent scan.

1.5.2 Download Data

Download the data for the tag that is selected in the table. Once a tag has been found the user can then download the temperature data from that tag. This is achieved by selecting the tag from the “Found Tags” table and clicking the Download button. The user will then be presented with a progress screen where the data download progress is shown and the user is given the option to cancel the download. If the user chooses to cancel the download a warning message is shown to inform the user that the partially downloaded data will be saved with this tag. If the user chooses “Yes” to continue the cancellation, then the incomplete data can be used in the Shelf-Life Algorithm. If the user chooses “No”, then the download operation continues as normal. If the user chooses “Cancel” then the download is stopped and the user is taken back to the main screen. Figure 34 shows examples of the download screens.

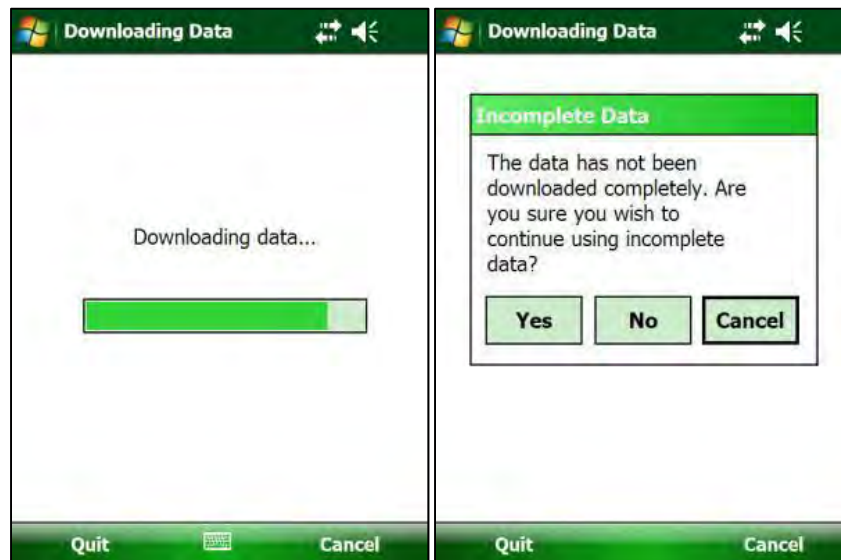

Figure 34. Downloading Tags with CAEN Reader

If a tag’s status is set to any status other than “Not Downloaded”, the tag data can be viewed from the main screen by selecting the tag and choosing “Menu” -> “View Data”. This will present the user with the algorithm result and chart screen.

To remove an individual tag from the “Found Tags” table a user can either press and hold on the tag entry and click “Remove From List” or select the tag and choose “Menu” -> “Remove”. To clear the table of all tags a user can select “Menu” -> “Remove All”.

1.5.3 Run Shelf-Life Algorithm

The “Run Self-Life Algorithm” function (Figure 35) initiates the Shelf-Life Algorithm and uses the displayed data as input into the algorithm. The algorithm determines whether the product has expired or is still good and displays this status on the screen. The status is also updated for the tag on the main screen.

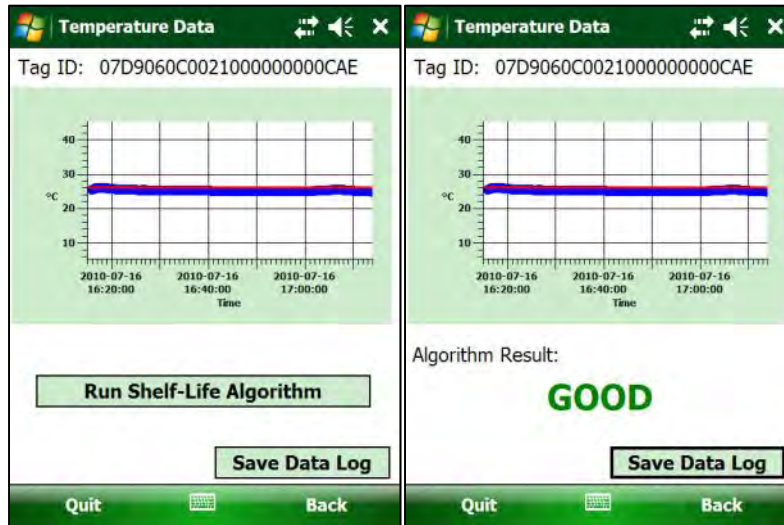

Figure 35. Running the Shelf-Life Algorithm with CAEN Reader

If the “Run Shelf-Life Algorithm” button is displayed in the algorithm result and chart screen then this tag’s temperature data has not been run through the Shelf-Life Algorithm. Clicking the “Run Shelf-Life Algorithm” will update this tag’s temperature data and determine if the product is good or expired. Once the algorithm completes, the status is displayed and updated on the main screen. Depending on the configuration settings, the application will send the status update along with the raw temperature data to the email addresses specified in the configuration file.

As mentioned previously, for the CAEN system, the output of the algorithm simply displays the current pallet condition. The software development effort for the second part of the Shelf-Life Algorithm which actually estimates the “time-to-expire” or the remaining shelf life from the current pallet condition, was completed for the Intellex system.

The user also has the option to save the data log, which contains the raw temperature data, to a file on the Windows Mobile file system. This is done by pressing the “Save Data Log” button on the algorithm result screen. To access this file, connect the Windows Mobile device to a Windows based computer, open the ActiveSync program, choose the explore button, double-click on “My Windows Mobile-Based Device” -> “Program Files” -> “shelflifemonitor”. In here you’ll find all of the data logs along with application specific files. The data logs are named “DataLog” followed by the tag ID and the date the log was created. Copy and paste the log from the shelflifemonitor file onto the computer. Once the log has been copied over it can be viewed

with text editor (i.e. Notepad). The log can also be viewed directly from the Windows Mobile device by opening the File Explorer and navigating to the directory containing the logs.

Note: If the algorithm result is displayed with a “*” next to it, it’s because this tag’s data was run through the Shelf-Life Algorithm with partially downloaded data. In order to display the status without the “*”, the tag’s data will need to be fully downloaded from the main screen.

1.5.4 Tag Admin

Users have the ability to start and stop the logging for each CAEN RFID Temperature Tag. This is handled through the tag admin section, which is accessed through the menu on the main screen. Through this interface the user can also set the sampling interval of the temperature data and refresh the tag’s logging status.

The Shelf-Life Monitor application contains a module for administering the CAEN temperature tags, which provides functionality for starting and stopping the logs and setting the sampling interval. This module is accessed by selecting a tag from the main screen then navigating to “Menu” -> “Admin Menu” -> “Tag Admin”. On the tag administration screen the user will be presented with the following tag information.

- ⇒ Tag ID – The ID of the tag currently being administered
- ⇒ Logging Status – Informs the user as to whether this tag is currently logging data or not logging any data.
- ⇒ Number of Samples – The total number of samples that have been logged by this tag.
- ⇒ Log Start Time – The time that this tag’s logging session was started.
- ⇒ Sampling Interval – The interval at which each temperature sample is logged for this tag.

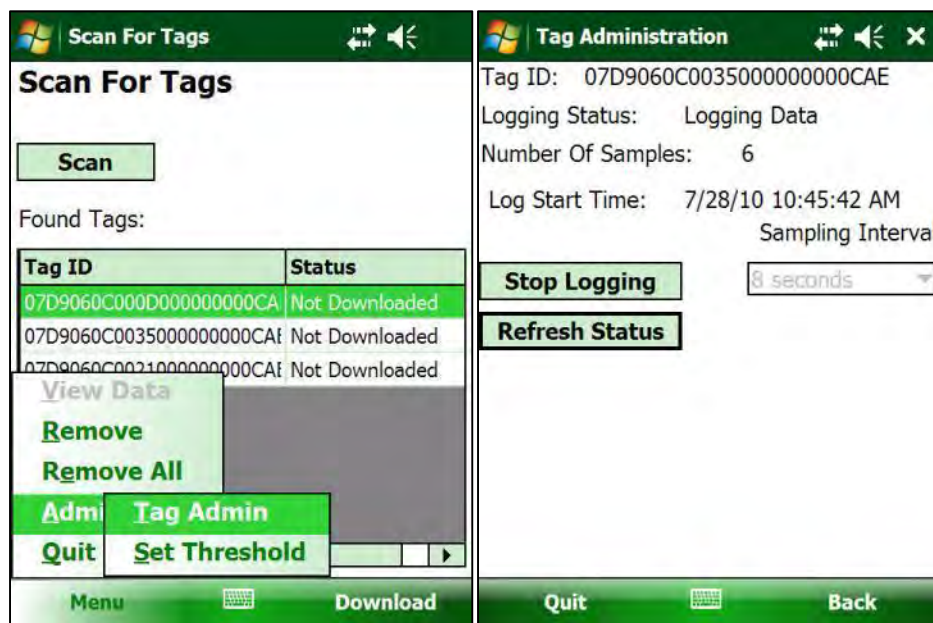

Figure 36. Tag Admin for CAEN Reader

To commission the tag for logging the user must choose the sampling interval, click on the “Start Logging” button and agree to erase the tag’s current temperature log. The tag log can only be started if the tag is not currently logging.

The CAEN RFID temperature tag supports the ability for a log to be stopped and started without erasing the log; however, because the Shelf-Life Monitor implementation does not log timestamps, the temperature data timestamps would be calculated incorrectly. The application calculates the timestamps based on start time and sampling interval and any gaps between temperature samples would not be identified if the log was not erased upon restart. Once the tag log has been started, the tag administration screen will be updated to reflect the new information such as sampling interval, start time, and number of samples.

Note: The tag’s log does not have to be stopped for a user to download the tag’s data and run it through the Shelf-Life Algorithm.

To stop the tag’s current logging session, the user must click the “Stop Logging” button and agree to finalize this tag’s logged temperature data. The tag log can only be stopped if the tag is currently logging.

The purpose of finalizing the tag’s logging session is due to the fact that the timestamps cannot be accurately calculated if there are gaps in the temperature logs. This warning is informing the user that when this tag’s log is restarted the currently logged data will be erased and a new logging session will be started.

Once the tag log has been stopped, the tag administration screen will update the logging status.

Note: This tag’s data can still be downloaded and run through the Shelf-Life Algorithm after the log has been stopped. Once the log is restarted the data will be lost.

1.5.5 Configuration File

The Shelf-Life Monitor application reads parameters from a configuration file that can be edited on the device through the Windows Mobile ActiveSync application. To access the configuration file, ensure the device is connected to a Windows based computer, open Microsoft ActiveSync, select Tools ->Explore Device. This should open a new Windows Explorer window into the device. Double click on “My Windows Mobile-Based Device” -> “Program Files” -> “Shelf Life Monitor”. Copy and paste the configuration file “App.config” from the device onto the computer (the file cannot be edited directly on the device). Open the configuration file in a text editor (i.e. Notepad).

The configuration file contains the following parameters:

- ⇒ Algorithm Threshold – Sets the threshold of the Pseudo Shelf-Life Algorithm. This can also be done via the Shelf-Life Monitor application Admin section.

- ⇒ Send Email Enabled – Whenever the Shelf-Life Algorithm is run on temperature data, an email is sent containing the tag ID, status, and data log file. This parameter enables and disables that email from being sent. Setting the parameter to 1 enables emailing and 0 disables emailing.
- ⇒ Email Address Recipients – Determines the recipients for the Shelf-Life Algorithm email sent stated above. Must be in a semi-colon delimited string (i.e. email1@domain.com;email2@domain.com).
- ⇒ Pocket Outlook Account Name – The name of the email account provider that has been setup on the device for sending the Shelf-Life Algorithm status emails. This email account must be setup on the device for the Shelf-Life Monitor application to send the status emails. For more information on setting up email accounts on Windows Mobile 6.1, see <http://www.microsoft.com/windowsmobile/en-us/help/v6-0/Send-Receive-Email-touch.aspx>

Once these parameters have been set, save the configuration file (must be named “App.config”). Copy and paste the saved configuration file from the computer back onto the device from the same location you retrieved the file from. When the application is reopened, the new configuration parameters will be used.

1.5.6 Error Conditions

It is important for the user to understand the error conditions that occur when the Shelf-Life Monitor application attempts to connect to the CAEN RFID Temperature Tag and the connection has been lost. This section explains the different error conditions, how they can be mitigated, and their significance in operating the application and tags.

- ⇒ The CAEN RFID Temperature Tag contains memory for storing the temperature data that has been logged since the logging session was started. This memory is a fixed size and will eventually be filled up once the device has logged enough data. Whenever the memory is full, the tag will erase a block of old data and begin storing the new data in its place. Deleting temperature data renders the algorithm result unusable because all historical data is needed to determine if the product is good or expired. Therefore, the Shelf-Life Monitor application informs the user that a tag with full memory cannot be checked with the Shelf-Life Algorithm. The tag will need to be restarted so the old log can be deleted.
- ⇒ The Shelf-Life Monitor application attempts to scan for tags by probing the area multiple times for CAEN RFID Temperature Tags. If there are no tags available then the user is informed with an error message. Given the range limitations of RFID transmissions, it is important for a user to aim the handheld in the general direction of the tag that the user is trying to scan. The user could potentially press the “Scan for Tags” button and point the handheld at multiple tags in an effort to gather as many tags as possible in one sweep.

- ⇒ When a user begins downloading data from a selected tag, the RFID transmission could be interrupted due to interference or the tag going out of range. The Shelf-Life Monitor application tries to reconnect to the tag multiple times before displaying an error message that the tag's connection has been lost. If the download has not completed, the user will be directed back to the main screen where the download can be retried. The user could begin the download and then point the handheld in the direction of the tag that the user is trying download data from in an effort to keep the connection open long enough to gather all of the data.
- ⇒ When a user chooses the "Tag Admin" option for a selected tag, the Shelf-Life Monitor application will attempt to connect to the tag and download all of the status information such as logging status and start time. If the application cannot connect to the tag initially, an error message will be displayed and the user will remain at the main screen. Otherwise the tag is connected and the status is read and the user is presented with the tag administration screen.
- ⇒ The options available to the user from the tag administration screen are start logging, stop logging, and refresh status. When a user starts the logging session, the application sends commands to the tag to delete its current log, reset the start time and sampling interval, and begin a new logging session. When a user stops the logging session, the application sends commands to the tag to simply stop the logging session. During these operations the application needs to connect to the tag multiple times. At the beginning of the start and stop commands the application connects to the tag to send it start and stop command information then attempts to update the status information on the admin screen. There's a possibility that the commands were sent to the tag without errors, but the connection was lost when the status information was attempting to be refreshed. In this case, the application will inform the user that the start or stop action was completed successfully, but the connection was lost to refresh the status. The tag administration screen will show "Error" for all fields except the "Logging Status". If the application was unable to send the initial start or stop command information, then the application will inform the user that a connection to the tag could not be made and the state of the tag has not been changed.

1.5.7 Pricing

It is important to note that the price levels for both the Workabout Pro 2 handheld computer integrated with the RFID module and the A927Z Caen temperature tags are constantly changing. At the time of this writing, a Workabout Pro 2 handheld integrated with the Caen RFID module costs roughly around \$4,000, which falls below the requirement threshold of \$5,000. As far as the Caen A927Z temperature tags are concerned, the biggest effect on the price is the volume of purchase as the price varies greatly with the number of tags being purchased. At the time of this writing, for a 100 tag purchase the cost is roughly around \$30 per tag, which is pushing the higher limit of the cost requirement.

1.6 General Information and System Overview for Intellex System

This radio-frequency identification system uses a Motorola MC9090 handheld computer integrated with an Intellex RFID reader module to communicate with RFID temperature loggers TMT-8500 manufactured by Intellex. At the time of this writing, Intellex has also started marketing a Motorola MC9090 based handheld device (Figure 37), which comes integrated with their compact reader module, called HMR-9090 handheld reader. The detailed datasheet for the tags and the handheld can be found in the Appendix B.

The application software is based on the Windows Mobile operating platform. It has the functionality to use the Intellex reader module to communicate with the TMT-8500 tags (Figure 38) to start/stop and record RFID tags and run a temperature-based Shelf-Life Algorithm on the downloaded data.



Figure 37. Motorola MC9090 /w Intellex reader module



Figure 38. Intellex TMT 8500 temperature tag

In this manual, the user can see how the software works to communicate with the RFID tags along with some of its basic and more complex functionalities. Figures 39 to 61 and their descriptions give the user detailed instructions on how to operate the system. It is recommended that the user follows the walkthrough as presented in this manual at least once before operating the system to have a better understanding of different menu options and system functionality.

Please note that in the manual below, each figure is immediately followed by their corresponding explanation for better understanding of software functionality.

1.6.1 Main Screen and Basic Operations

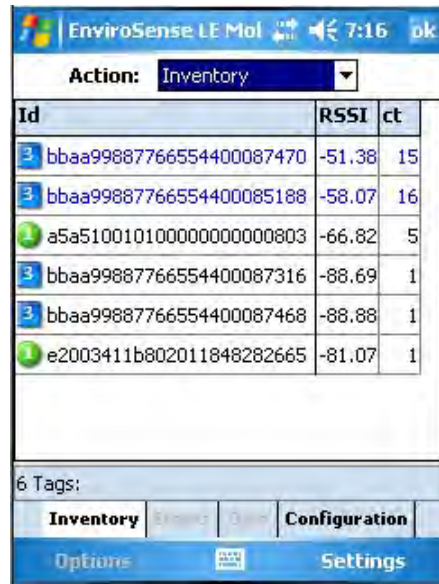

Figure 39. Main screen of the UI for Intellex reader

This is the main screen of the user interface (UI) for the handheld based software for Intellex system. On this screen the user can see which tags were last seen in the vicinity of the handheld reader when the trigger was pulled, what the received signal strength indication (RSSI) was for each tag (indicating the relative distance of the tag to the reader) as well as how many number of times the reader has seen the tag in count (ct) column.

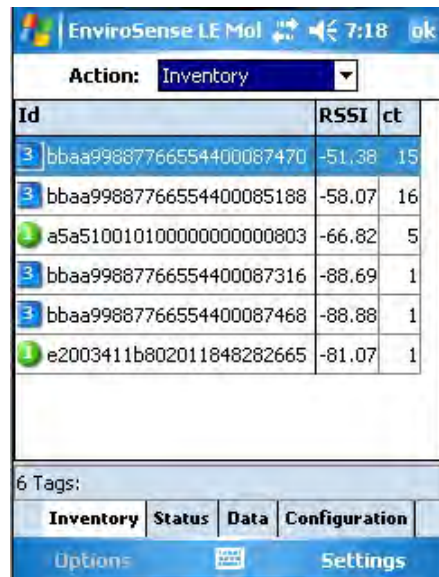

Figure 40. Main screen of the UI for Intellex reader with specific tag selected

This is what the screen looks like when a specific tag is selected. As you can see, the “Status” and “Data” options are highlighted once a particular tag is selected. The user can now select

Status to see the status of the tag (more information on that below), Data to see the recorded temperature data in the tag or Configuration to configure the tag.

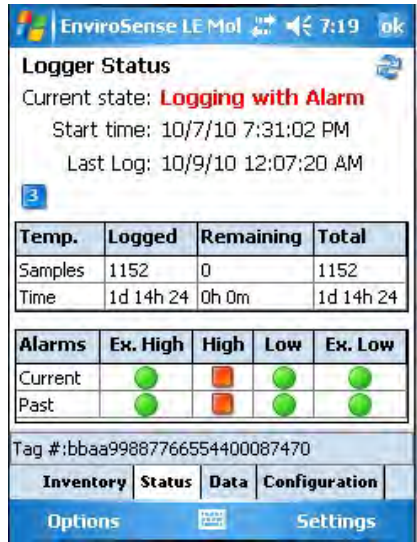

Figure 41. Status tab of Intellex reader displaying high temperature alarm

Once the user clicks on Status tab, he can see detailed information about the tag, such as its current state (running, stopped, running with alarms, stopped with alarms, etc.), when the tag was started, when was the last time it recorded a temperature, how many temperature samples it has recorded so far, and how much memory is left on the tag to keep recording new temperatures. In addition to this, the user can also see the total amount of time the tag has been recording as well as the types of alarm flags that the tag has turned on. With Intellex tags, the user can define four temperatures for alarms: high, extreme high and low, extreme low. On Status screen these alarms are displayed as shown in the picture.

1.6.2 Downloading Data

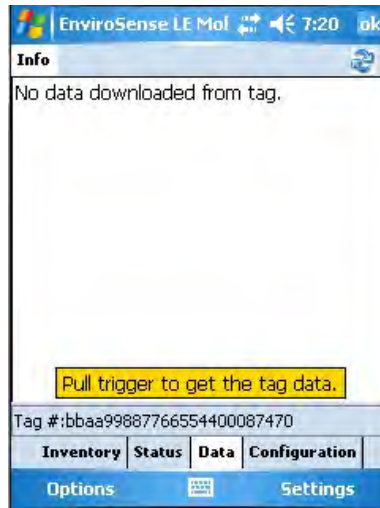

Figure 42. Data tab of Intellex reader

Similar to the Status window, the user can click on Data to see if any data was downloaded for the tag before to the handheld. If so, the user can see this data in a tabular temperature-time format. If not, the user can pull the trigger of the handheld to start downloading data from the tag to the handheld.

The screenshot shows the 'Data' tab of the Intellex reader. The title bar reads 'EnviroSense LE Mol' with a signal strength indicator, a battery icon, and the time '7:27'. The main content area displays a table with two columns: 'Timestamp' and 'Temp.'. The table contains 12 rows of data, with the last two rows highlighted in red. Below the table is a field for 'Tag #: bbaa99887766554400087470' and a navigation bar with buttons for 'Inventory', 'Status', 'Data', 'Configuration', 'Options', and 'Settings'.

Timestamp	Temp.
10/7/10 7:33:03 PM	78.08 °F
10/7/10 7:35:03 PM	77.76 °F
10/7/10 7:37:03 PM	77.76 °F
10/7/10 7:39:03 PM	77.97 °F
10/7/10 7:41:03 PM	78.31 °F
10/7/10 7:43:04 PM	82.71 °F
10/7/10 7:44:04 PM	85.73 °F
10/7/10 7:45:04 PM	87.53 °F
10/7/10 7:46:04 PM	88.66 °F
10/7/10 7:47:04 PM	89.56 °F
10/7/10 7:48:04 PM	90.23 °F
10/7/10 7:49:04 PM	90.81 °F

Figure 43. Temperature timestamp information on Intellex reader

Once the download is successfully completed, the user can see the temperature-time stamp information recorded in the tag. On the left column the timestamp for which the temperature data was recorded is displayed. In this example, the tags were configured to record temperature every 2 minutes as can be seen from this screenshot. On the right column, the user can see the associated temperature with that timestamp. In this example, the

temperature is stored as Fahrenheit but it can be configured to be stored in Celsius as well. Please note that two new options are now available to the user once the temperature data is downloaded: Waypoints and Info.

Temperatures		Waypoints	Info
Timestamp	Temp.	Waypoint	
10/7/10 7:33:03 PM	78.08 °F	10/10/10 9:28:44 AM	WP: 7
10/7/10 7:35:03 PM	77.76 °F		
10/7/10 7:37:03 PM	77.76 °F		
10/7/10 7:39:03 PM	77.97 °F		
10/7/10 7:41:03 PM	78.31 °F		
10/7/10 7:43:04 PM	82.71 °F		
10/7/10 7:44:04 PM	85.73 °F		
10/7/10 7:45:04 PM	87.53 °F		
10/7/10 7:46:04 PM	88.66 °F		
10/7/10 7:47:04 PM	89.56 °F		
10/7/10 7:48:04 PM	90.23 °F		
10/7/10 7:49:04 PM	90.81 °F		
Tag #:bbaa99887766554400087470			
Inventory	Status	Data	Configuration
Options		Settings	

Figure 44. Waypoints tab of Intellex reader

Once the user clicks to Waypoints, he can see when the tag has been to or passed a particular waypoint. Waypoints can be defined in the system as specific warehouses or distribution points and can carry crucial information when the logistics history of the shipment is required.

Temperatures		Waypoints	Info	Write Info
Timestamp	Temp.	This is where the user data goes. Now I can write it to tag.		
10/7/10 7:33:03 PM	78.08 °F			
10/7/10 7:35:03 PM	77.76 °F			
10/7/10 7:37:03 PM	77.76 °F			
10/7/10 7:39:03 PM	77.97 °F			
10/7/10 7:41:03 PM	78.31 °F			
10/7/10 7:43:04 PM	82.71 °F			
10/7/10 7:44:04 PM	85.73 °F			
10/7/10 7:45:04 PM	87.53 °F			
10/7/10 7:46:04 PM	88.66 °F			
10/7/10 7:47:04 PM	89.56 °F			
10/7/10 7:48:04 PM	90.23 °F			
10/7/10 7:49:04 PM	90.81 °F			
Tag #:bbaa99887766554400087470				
Inventory	Status	Data	Configuration	
Options		Settings		

Figure 45. Info tab of Intellex reader

Similarly, when the user selects the Info tab, he can see any custom information about the tag that was written to the memory beforehand. For example, if there is any irregularity with the

shipment of a particular pallet such that if it had been delayed, or if it had fewer cases in the pallet than the others, this information can be stored in the Intellex tag and observed in this tab.

1.6.3 Charting Temperature Data and Shelf Life Algorithm

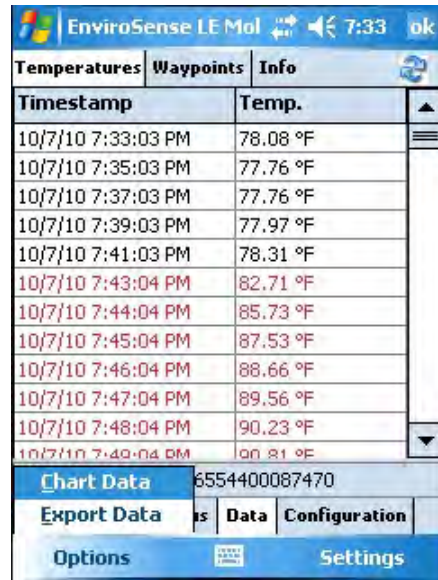

Figure 46. Options in the temperatures tab of Intellex reader

In the main Temperatures tab, the user can click on Options to either chart the temperature data to see the temperature history in graphics format, or export the data into a different file format to be used by another application.

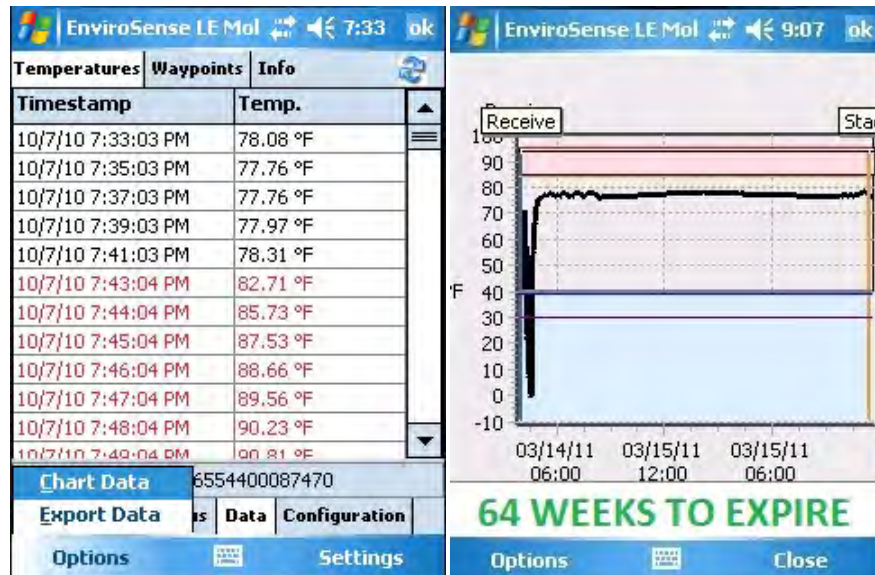

Figure 47. Example of shelf life graph of product with more than half of its shelf life still available

If the user selects to chart the data, a window similar to the one above will appear. On the x-axis the user can see the timeline of the recorded temperature history and on the y-axis the temperature itself is displayed. When the user chooses to chart the data, the shelf life status of the product will also be displayed with the following three possibilities: the product has either more than half of its shelf life still available (as shown above), less than half of its shelf life available or is expired (as shown below). To get the following screenshots, the parameters of the algorithm were modified to display all the available outcomes using the same temperature curve.

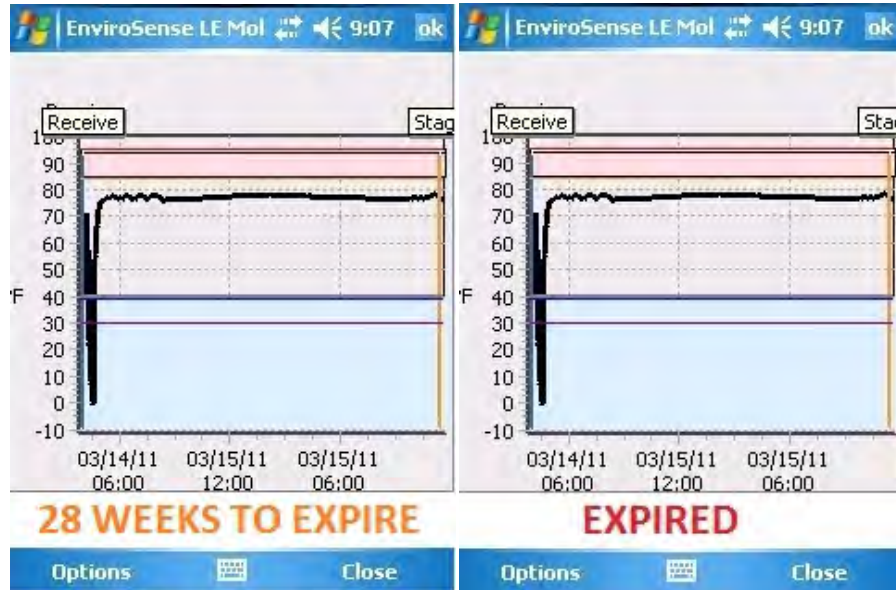

Figure 48. Examples of shelf life graphs displaying other outcomes

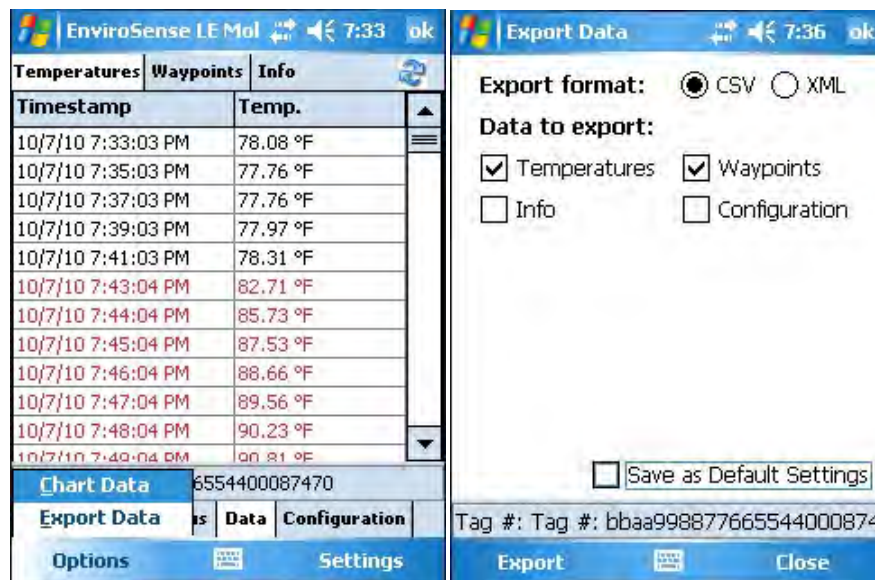

Figure 49. Export data option for the Intellex reader

The next option is to export the temperature data into another file format to be used in another application. For example, the user can store temperatures, time stamps, waypoints, user-defined information about the tag and tag configuration in either CSV or XML format. This utility will become useful when this data needs to be transferred off to a main server for further analysis or utilization.

1.6.4 Tag Configuration and Advanced Functionalities

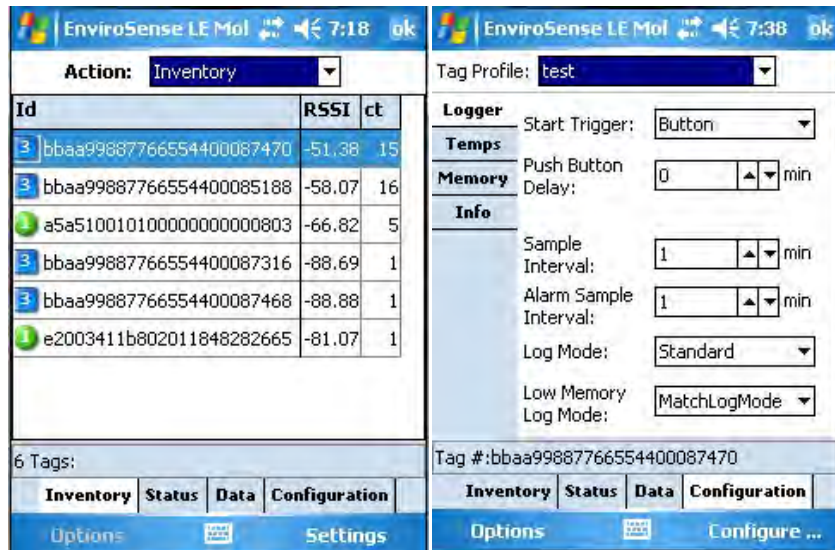

Figure 50. Configuration tab of Intellex reader

From the main screen the user can also go the configuration tab where important parameters such as how the tag will be started, what will the sampling rate be, if there will be a different sampling rate once an alarm threshold is crossed, etc. are defined. Please note that not all users in the system have or need access to this configuration information. In the first tab of the configuration window, Logger, the user can define tag-specific configuration parameters such as sampling interval, alarm sampling interval, how the information will be stored and how the information will be stored when the tag is running low on memory.

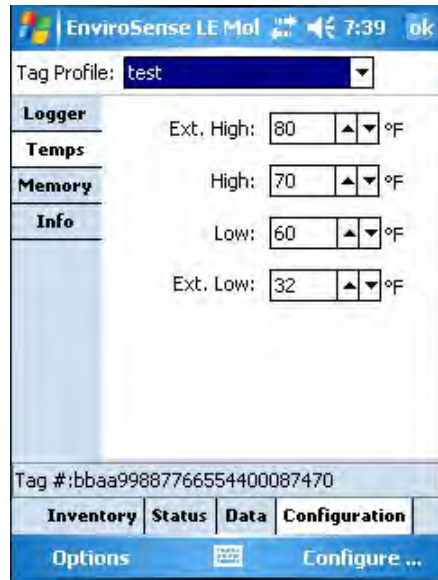

Figure 51. Temps tab in configuration window of Intellex reader

On the Temps tab of the configuration window, the user can define what the alarm temperature thresholds will be such as the low/extreme low and high/extreme high alarm temperatures.

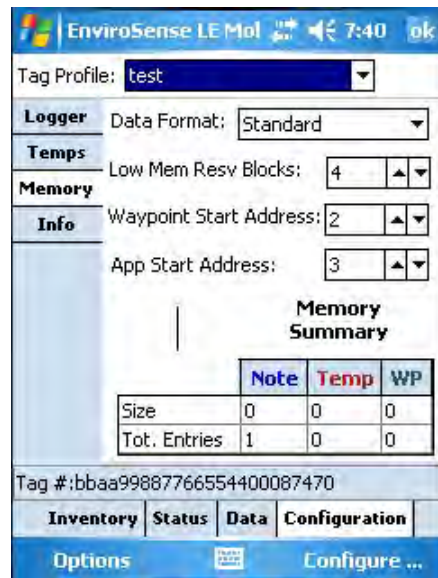

Figure 52. Memory tab in configuration window of Intellex reader

The memory tab of the configuration window has advanced functionalities that should not be of concern to the typical user of the software and can actually be disabled by the program administrator.

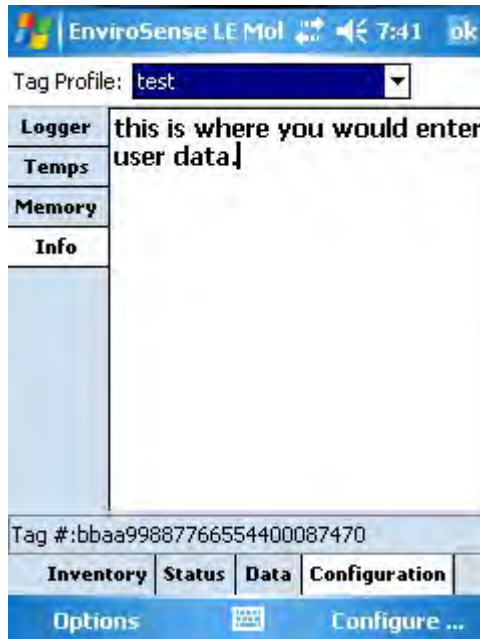

Figure 53. Info tab in configuration window of Intelleflex reader

Finally the Info tab of the configuration window is where the user can input tag (or pallet) specific information such as any irregular details about the shipment, etc.

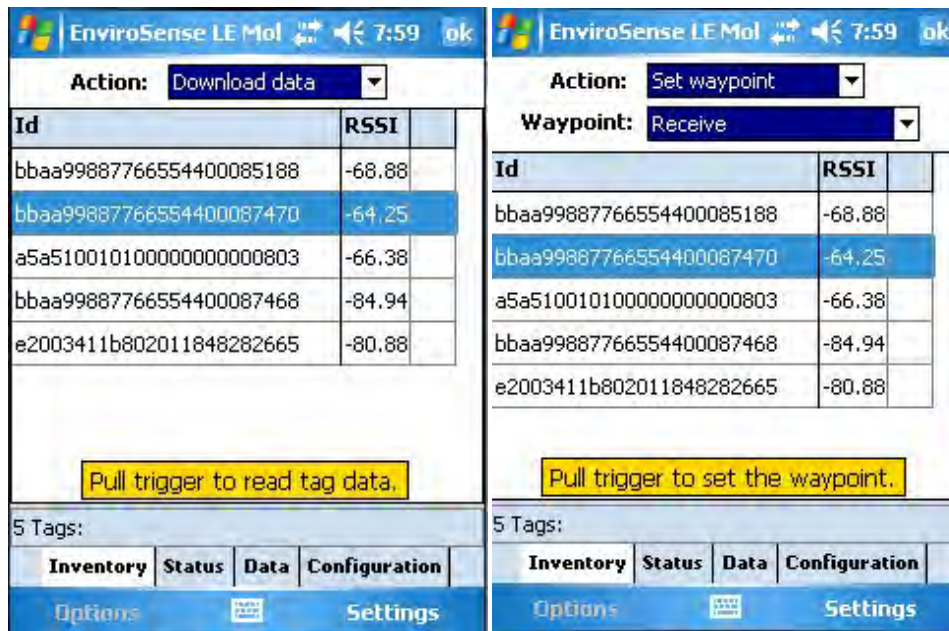

Figure 54. Waypoint tab of Intelleflex reader

From the home screen, the user can also pick between different actions to perform with the tag. So far, we have explained the download functionality for the recorded temperature data. The user can also pick a different option from the pull down menu, for example set waypoint, and assign it to the tag of choice by pulling the handheld reader trigger.

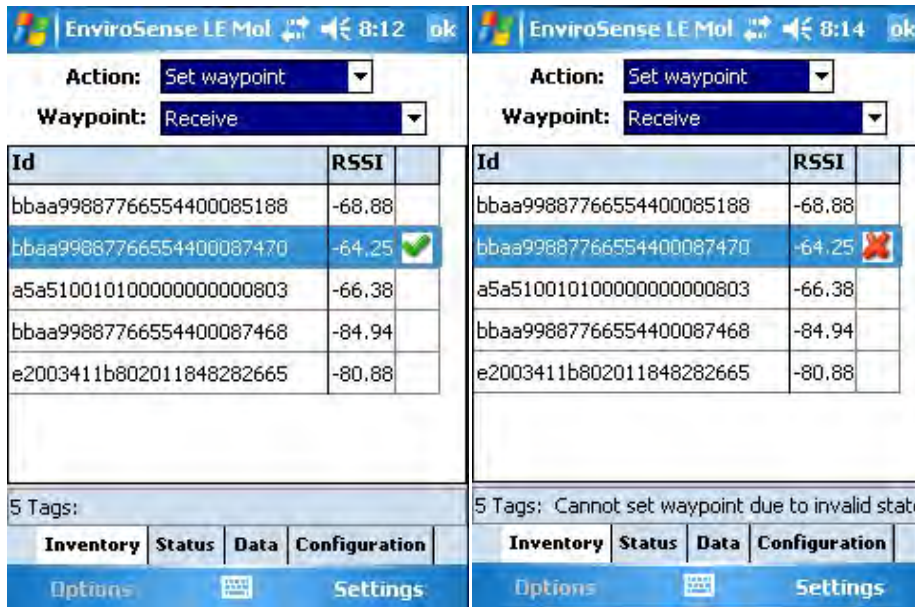

Figure 55. Successful and Unsuccessful Attempts at Setting Waypoint on Intellex reader

Once the waypoint is successfully set, the user will receive visual confirmation in the form of a green checkmark next to the tag for which the waypoint was set. As explained before, setting waypoints are especially useful when tracking the logistics history of a particular shipment. For example, each handheld in different destinations, shipper warehouse, distribution warehouse, destination point etc. can have a different waypoint ID, and when the waypoint is set on a tag, the user will know the exact time the shipment was received at that specific waypoint in the supply chain. If the waypoint was not able to be set successfully, the user will see a red cross and should try it again.

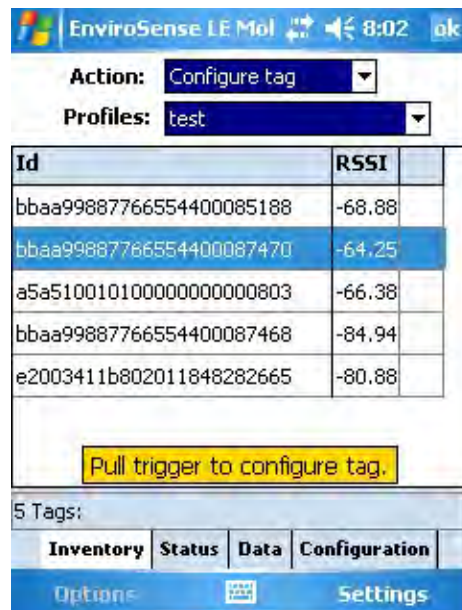

Figure 56. Configuration of Tags with Intellex Reader

From the same home screen, where the users can select Download/Waypoint, they can also choose to configure a specific tag. The configuration parameters can be accessed from the Configuration tab as explained in the earlier pictures. In order to configure a tag with the defined parameters, the user needs to click the tag to be configured and then pull the handheld reader trigger.

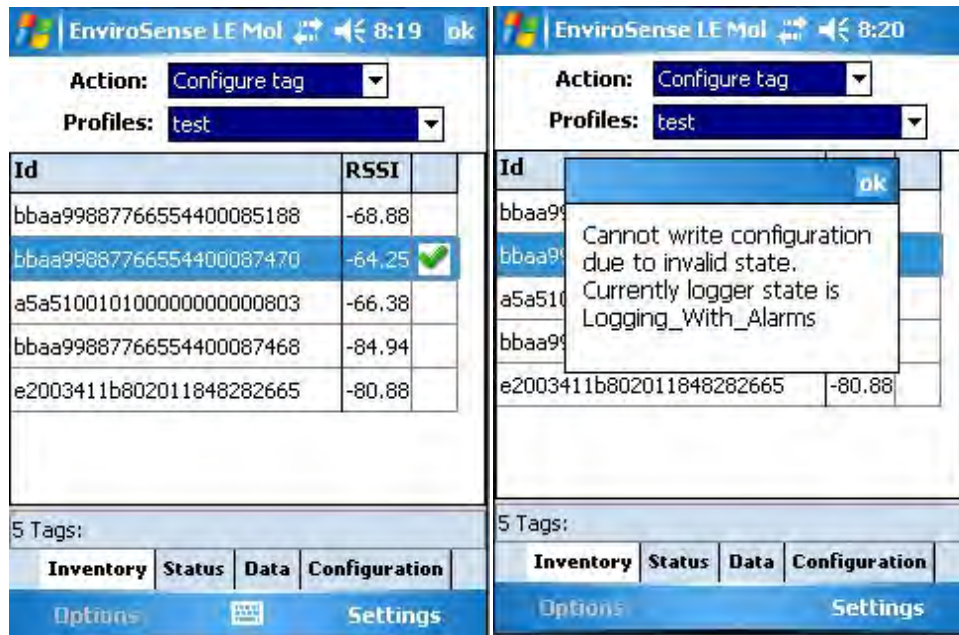

Figure 57. Successful and Unsuccessful Configurations of Tags with Intellex Reader

Once the configuration of the tag is successfully completed, the user will see a green checkmark next to the tag being configured. In cases where the configuration could not be completed due to a number of reasons, such as the tag is no longer in the field of the reader, the tag was not stopped prior to being configured (as shown in the picture) the user will be notified with the cause of configuration failure and how to fix the problem. In this case, the logger was not stopped prior to configuration.

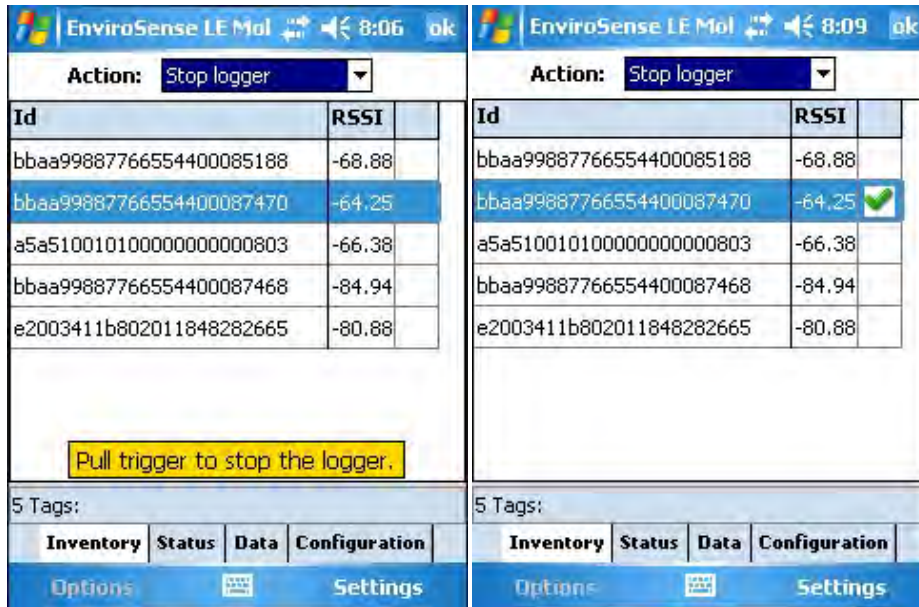

Figure 58. Stopping Tags from Logging with Intellex Reader

In order to stop a particular tag, the user will use the same drop down menu and pick Stop Logger option. Afterwards, he has to click on the tag that needs to be stopped logging and then pull the handheld reader trigger to complete the operation. Once the operation is completed, a green check mark will appear next to the tag ID indicating that the tag was successfully stopped.

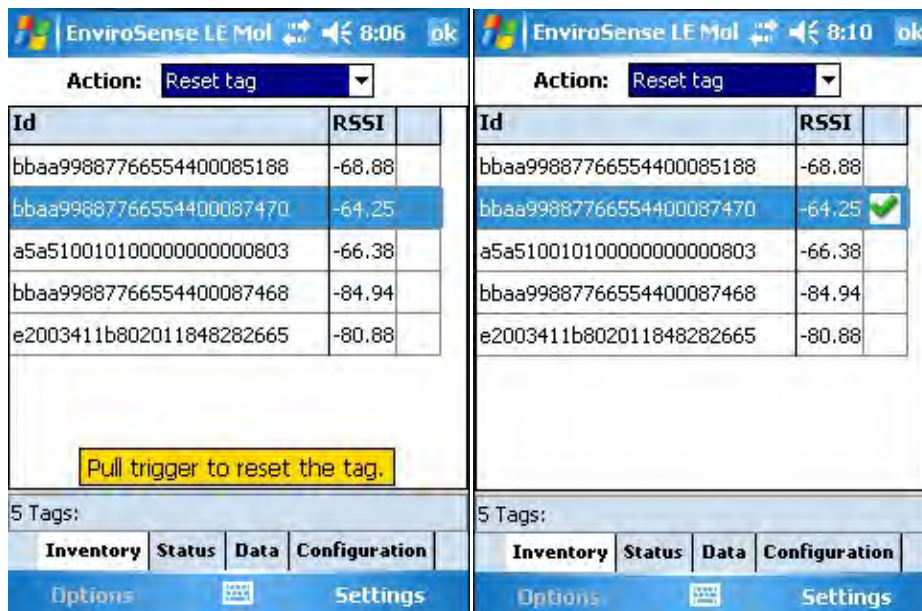

Figure 59. Resetting Tags with Intellex Reader

In order to start a logger, the user can either select configuration options such that the tag will start automatically after a fixed period of time, such as 1 hour, or 5 minutes, after the

configuration parameters are sent to the tag. Alternatively, the user can start the tag by using the handheld reader trigger. In order to do this, the tag needs to be in reset state. He can select reset tag option from the same drop down menu and pull the trigger of the handheld reader. A green check mark will ensure that the resetting operation has been successfully completed, after which the user can start the tag.

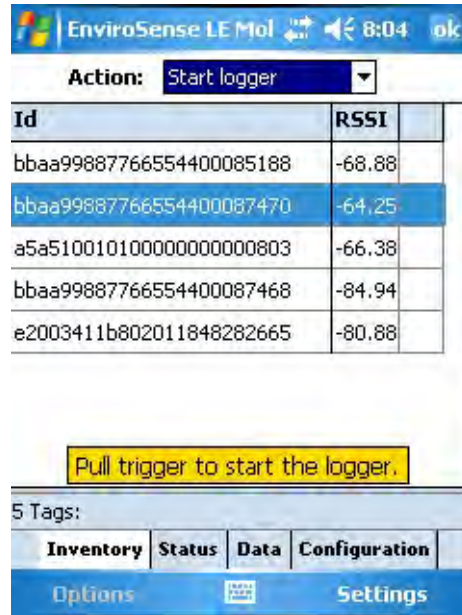

Figure 60. Properly Reset Tag in Intellex Reader

Once the tag is reset and is in the right state, the user can click on the tag, choose the start logger option from the drop down menu and pull the handheld reader trigger to start the tag.

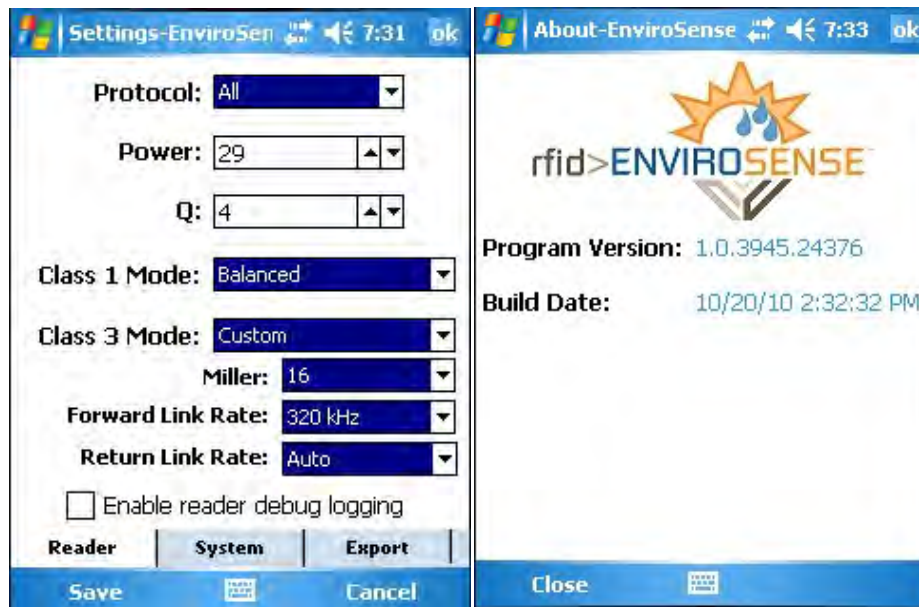

Figure 61. Settings Window of Intellex Reader

In addition to basic user functionalities, the software also enables the user to access more detailed RFID reader characteristics such as mode of communication, reader output power, Miller coefficient, forward and return link bit rates, through the Settings window. However, the discussion of these features is beyond the scope of this manual and can also be disabled once the optimum parameters are set by the program administrator.

1.6.5 Pricing

Just like the Caen system, it is important to note that the price levels for both the Motorola MC9090 computer integrated with the Intellex RFID module and the TMT-8500 Intellex tags are in constant flux. Similar to the Workabout Pro 2 handheld, at the time of this writing, a Motorola MC9090 handheld integrated with the Intellex RFID module costs roughly around \$4,000, which falls below the requirement threshold of \$5,000. The price of the TMT-8500 tags is greatly affected by the volume of the purchase, but at the time of this writing, for a 100 tag purchase the cost is roughly around \$20 per tag, which falls in the middle of tag cost requirement range.

1.7 Conclusions - Validation and Final Recommendations

To conclude, at the end of the first phase of the project, the following Objective 1 goals have been successfully accomplished:

- ⇒ Extensive market search and identification of candidate technologies
- ⇒ Development and administration of a novel testing protocol to identify the most reliable and accurate temperature tracking technology satisfying project requirements
- ⇒ Construction of a shelf life computer model that can run on a portable device to estimate the status of an FSR shipment based on prior temperature history recorded by the RFID temperature tag
- ⇒ Two fully functional and portable prototype systems and respective software development to integrate tag-handheld communication with shelf life estimation
- ⇒ Initial validation of the prototype systems at the final project meeting

On December 8th, 2010, we had a Phase I project wrap-up meeting to present our results and demonstrate the prototype systems we have developed for the project. The meeting took place at the University of South Florida Polytechnic in Lakeland, FL, with the following participants from all the parties involved in the project:

- ⇒ Joseph Zanchi, Natick Soldier Research, Development and Engineering Center
- ⇒ Harry Kirejczyk, Natick Soldier Research Development and Engineering Center
- ⇒ John Smith, U.S. Army Veterinary Command
- ⇒ Melody Arnold, U.S. Army Veterinary Command
- ⇒ Jean-Pierre Émond, University of South Florida Polytechnic
- ⇒ Ismail Uysal, University of South Florida Polytechnic
- ⇒ Cecilia Nunes, University of South Florida Polytechnic

- ⇒ Magalie Laniel, University of South Florida Polytechnic
- ⇒ Melissa Germain, University of South Florida Polytechnic
- ⇒ Sencer Yeralan, University of South Florida Polytechnic
- ⇒ Jeffrey Brecht, University of Florida
- ⇒ Steve Sargent, University of Florida
- ⇒ Charles Sims, University of Florida
- ⇒ Yavuz Yagiz, University of Florida
- ⇒ Gisele Bennett, Georgia Institute of Technology
- ⇒ Jeffrey Wells, Franwell Inc.
- ⇒ Praveen Limbachiya, Franwell Inc.

1.7.1 Validation

As part of our initial validation effort, at this meeting we were able to successfully demonstrate the full functionality of both systems we have developed for the project. In this demonstration, we were able to show that both handheld systems:

- ⇒ Can see tags within their antenna fields.
 - Intellex system displayed better read range capabilities than Caen in this demonstration
- ⇒ Can initialize and start the tags.
- ⇒ Can download recorded temperature information from the tags.
- ⇒ Can run the shelf life algorithm on the downloaded temperature information to determine an expired/non-expired decision.

1.7.2 Final Recommendations

Since the environmental simulation tests have been running concurrently with software development, we wanted to have a fully functional prototype for each system in case one system proved to be better than the other at the end of our extensive testing protocol, potentially causing delays due to lack of software development for that particular system.

Even though both prototype systems functioned well as demonstrated at the Lakeland meeting, based on their comparative performance in environmental testing results (as reported in Section 2.3), as well as the read range testing results (also reported in Section 2.3), the Intellex system looks to be the better candidate for a possible future implementation in estimating the shelf life for FSR systems. Even though tags from both manufacturers have shown high accuracy in both temperature accuracy and environmental simulation tests, two of the Caen tags failed in the freezing temperature test. In addition, Intellex system, based on its advanced class 3 communication protocol, is more future-ready in terms of adaptability to other systems and RFID readers.

Nonetheless, the Objective 1 team is aware of the fact that RFID technology, especially for sensor applications, is rapidly evolving, and for this reason, we have proposed to keep

evaluating new technologies in Phase II of the project as they are introduced to the market. As explained before, a great example of this is the fact that Intellex TMT-8500 tags were not available commercially when the project first started, yet they turned out to be the best candidate for this application. In the meantime, the rest of the system development efforts proposed for Phase II, from integrating the temperature estimation algorithm and the shelf life model, to database processing for smart distribution practices relying on shelf life and temperature data recorded by the RFID tags, will continue with the Intellex system.

2 Objective 2a: Physical and Compositional Attributes of FSR Items During Storage at Different Temperatures²

2.1 Introduction

First Strike Ration (FSR) is a compact lightweight product composed of several food items designed to be consumed by the Warfighters during short duration high intensity combat operations. The FSR is intended to enhance soldier food consumption, nutritional intake and mobility. Although it is known that the FSR has a minimum 2 year shelf-life when stored at 80°F and 6 month shelf life at 100°F, there is limited information about the quality and shelf-life of FSR when exposed to extreme ambient temperatures such as those commonly found in desert-like areas.

FSR menus are composed of different types of food products, each with particular physical and compositional characteristics. According to previous data collected by the NSRDEC, some items in each of the three menus are more predisposed to premature deterioration and may render the ration unsuitable for consumption.

The objectives of this work were: 1) study the effect of different storage temperatures, refrigerated and extreme ambient (high heat) temperatures, like those commonly encountered in desert-like environments, on the physical and compositional quality of nine selected FSR items; 2) generate quantitative data to validate the sensory data used in the design of the shelf life predicting model.

2.2 Materials and Methods

2.2.1 FSR Items

From the three currently available FSR menus; nine individual menu items were selected (Table 15). From Menu 1 the following items were evaluated: Filled French Toast Pocket (1), Bacon Cheddar Pocket Sandwich (2), Wheat Snack Bread (3), Beef Snack, Sweet BBQ (4), and Applesauce CHO Enhanced (5); from Menu 2: Italian Pocket Sandwich (6) and Tortillas (7); and from Menu 3: BBQ Beef Pocket Sandwich (8) and Dessert Bar, Chocolate Banana Nut (9). Of these nine items, two are common to all three menus, namely: Applesauce, CHO Enhanced (Zapplesauce) and Beef Snack, Sweet BBQ. Tortillas are common to Menus 2 and 3.

These nine menu items were identified by NSRDEC-Combat Feeding Directorate personnel as having been previously determined to be the most shelf life sensitive among all FSR menu items.

² Prepared by: Maria Cecilia N. Nunes, Ph.D., University of South Florida Polytechnic, Lakeland, FL

Table 15. First Strike Ration menus

Menu 1	Menu 2	Menu 3
Filled French Toast Pocket	Brown Sugar Cin Toaster Pastry	Lemon Poppyseed Pound Cake
Bacon Cheddar Pocket Sandwich	Italian Pocket Sandwich	BBQ Beef Pocket Sandwich
Pepperoni Pocket Sandwich	Chunk Chicken (Tyson, 7 oz) Tortillas	Albacore Tuna (Starkist, 3oz.) Tortillas
Cheese Spread, Jalapeno	Peanut Butter	Cheese Spread, Plain
Wheat Snack Bread	Cracker, Plain	Cracker, Plain
ERGO Drink	ERGO Drink	ERGO Drink
ERGO Drink	ERGO Drink	ERGO Drink
Mini HooAH! Mocha	Mini HooAH! Apple Cinnamon	Mini HooAH! Mocha
Mini HooAH! Chocolate	Mini HooAH! Cran-Rasp	Mini HooAH! Cran-Rasp
Dessert Bar, Peanut Butter	Dessert Bar, Mocha	Dessert Bar, Choc Banana Nut
Beef Snack, Sweet BBQ	Beef Snack, Sweet BBQ	Beef Snack, Sweet BBQ
Beef Snack, Teriyaki	Beef Snack, Teriyaki	Beef Snack, Teriyaki
Applesauce, CHO Enhanced	Applesauce, CHO Enhanced	Applesauce, CHO Enhanced
FSR Nut Fruit Mix, Type III	FSR Nut Fruit Mix, Type III	FSR Nut Fruit Mix, Type III
Gum, Stay Alert	Gum, Stay Alert	Gum, Stay Alert
	Mayonnaise, Fat Free	Mayonnaise, Fat Free
	Hot Sauce	Hot Sauce

Source: NSRDEC

Filled French Toast Pocket consists of flour, corn syrup, hydrogenated vegetable shortening, glycerol, sugar, dextrose, imitation maple syrup, yeast, salt tapioca starch, corn starch, sucrose ester, artificial and natural flavor, gum arabic, calcium sulfate, xanthan gum, cinnamon, cocoa, lecithin, sorbic acid FD&C yellow #5, and locust bean gum.

Bacon Cheddar Pocket Sandwich is prepared from bread and cured bacon, and contains the following ingredients: bread (enriched flour [wheat flour, niacin, reduced iron, thiamine mononitrate, riboflavin, folic acid], water, cheddar flavored flakes [hydrolyzed vegetable oil, corn syrup solids, wheat flour, milk, maltodextrin, salt, lactic acid, enzyme modified cheese; milk, salt, enzyme, natural flavors, sodium citrate, sodium carbonate, disodium phosphate, annatto as a color agent], partially hydrogenated soybean and cottonseed oil, glycerol, yeast, salt, sucrose ester, dough conditioners [dextrose, flour diacetyl tartaric acid esters of mono- and diglyceride, mono- and diglycerides, ascorbic acid, fungal alpha amylase, L-cysteine hydrochloride, azodicarbonamide], gum Arabic, butter flavor [modified food starch, maltodextrin, natural and artificial flavors, partially hydrogenated soybean oil, water, soy

lecithin], glucono-delta-lactone, calcium sulfate, xanthan gum, sorbic acid) and bacon (cured with water, salt, hickory smoke flavor, sugar, dextrose, sodium erythorbate, sodium nitrite).

Wheat Snack Bread is composed of enriched bleached flour (bleached flour, malted barley flour, niacin, reduced iron, thiamine mononitrate, riboflavin, folic acid), water, partially hydrogenated soybean and cottonseed oils, glycerol, sugar, wheat bran, contains 2% or less: hydrated monoglycerides, polysorbate 60, salt, extract of malted barley and corn, wheat starch, silicon dioxide, hydroxylated soy lecithin, soy flour, calcium sulfate, enzymes, sodium stearoyllactylate, leavening (sodium aluminum phosphate, baking soda), xanthan gum, gum arabic, corn syrup, sorbic acid, yeast, sorbitanmonostearate.

Beef Snack Sweet BBQ is made up of beef, water, hydrolyzed soy protein, sugar, salt, brown sugar, dextrose, corn syrup, flavorings, monosodium glutamate, smoke flavoring, extract of paprika, sodium erythorbate, sodium nitrite.

Applesauce CHO Enhanced, commercially known as Zapplesauce, consists of apples, maltodextrin, water, sugar, and ascorbic acid as vitamin C source. It was originally designed to increase the endurance of the soldiers by adding excess amounts of maltodextrin, which can preserve glycogen in the muscles and liver.

Italian Pocket Sandwich, which is prepared from bread, tomato sauce, marinated cooked sausage, pepperoni, and mozzarella cheese powder, contains following ingredients: bread (enriched flour [wheat flour, niacin, reduced iron, thiamine mononitrate, riboflavin, folic acid], water, cheddar flavored flakes [hydrolyzed vegetable oil, corn syrup solids, wheat flour, milk, maltodextrin, salt, lactic acid, enzyme modified cheese; milk, salt, enzyme, natural flavors, sodium citrate, sodium carbonate, disodium phosphate, annatto as a color agent], partially hydrogenated soybean and cottonseed oil, glycerol, yeast, salt, sucrose ester, dough conditioners [dextrose, flour diacetyl tartaric acid esters of mono- and diglyceride, mono- and diglycerides, ascorbic acid, fungal alpha amylase, L-cysteine hydrochloride, azodicarbonamide], gum Arabic, butter flavor [modified food starch, maltodextrin, natural and artificial flavors, partially hydrogenated soybean oil, water, soy lecithin], glucono-delta-lactone, calcium sulfate, xanthan gum, sorbic acid); tomato sauce (tomato paste [tomatoes, tomato juice, salt, citric acid], glycerol, parmesan/Romano cheese [pasteurized cow's milk, culture, salt, enzymes], olive oil, sugar, garlic powder, dried onions, spices, salt); marinated cooked sausage (Italian sausage [pork, salt water, dextrose, spices and flavorings, monosodium glutamate, sodium nitrite] rice syrup, glycerol, water, salt, spices); pepperoni (pork, beef, salt, water, dextrose, paprika, spices and flavorings, lactic acid starter culture, oleoresin of paprika, sodium erythorbate, sodium nitrite, BHA, BHT); mozzarella cheese powder (mozzarella cheese [pasteurized milk, cultures, salt, enzymes], disodium phosphate). The Italian Pocket Sandwich has a high source of proteins made up of about 21% meat.

Tortillas consists of ingredients including bleached flour (wheat flour, niacin, reduced iron, thiamine mononitrate, riboflavin, folic acid), water, vegetable shortening (partially hydrogenated soybean and/or cottonseed oil), glycerin, mono and diglycerides, baking powder

(corn starch, sodium acid pyrophosphate, sodium bicarbonate, and monocalcium phosphate), sugar and/or corn syrup, salt, fumaric acid, potassium sorbate, calcium propionate, sodium stearylactylate.

BBQ Beef Pocket Sandwich, which is prepared from bread and barbecue beef, contains the following ingredients: bread (enriched flour [wheat flour, niacin, reduced iron, thiamine mononitrate, riboflavin, folic acid], water, cheddar flavored flakes [hydrolyzed vegetable oil, corn syrup solids, wheat flour, milk, maltodextrin, salt, lactic acid, enzyme modified cheese; milk, salt, enzyme, natural flavors, sodium citrate, sodium carbonate, disodium phosphate, annatto as a color agent], partially hydrogenated soybean and cottonseed oil, glycerol, yeast salt, sucrose ester, dough conditioners [dextrose, flour diacetyl tartaric acid esters of mono- and diglyceride, mono- and diglycerides, ascorbic acid, fungal alpha amylase, L-cysteine hydrochloride, azodicarbonamide], gum Arabic, butter flavor [modified food starch, maltodextrin, natural and artificial flavors, partially hydrogenated soybean oil, water, soy lecithin], glucono-delta-lactone, calcium sulfate, xanthan gum, sorbic acid); barbecue beef (beef tomato paste [tomato paste, salt, citric acid], brown sugar, mustard, glycerol, honey, molasses, spices, and flavorings, beef broth, partially hydrogenated soybean oil, salt, partially polished brown rice syrup, vinegar flavor [sodium diacetate, citric acid, potassium citrate, glucono-delta-lactone], Worcestershire sauce [distilled vinegar, molasses, corn syrup, water, salt, caramel coloring, sugar, spices, anchovies, flavoring, tamarind, dried onions, smoke flavoring, sodium phosphate]). The BBQ Beef Pocket Sandwich provides a high source of proteins and contains about 21% meat.

Dessert bar Chocolate Banana Nut is composed of sugar, cream powder (cream, nonfat milk, dipotassium phosphate, silicon dioxide), chocolate chips (sugar, chocolate liquor, cocoa butter, dextrose, soy lecithin, vanillin), partially hydrogenated soybean and cottonseed oil, cocoa (processed with alkali), nonfat dry milk, contains 2% or less of: artificial flavor, spray dried coffee, ascorbyl palmitate, BHA, mixed tocopherols.

2.2.2 Storage Conditions

Three replicated samples/packages per individual FSR item were used for initial quality evaluation and a total of 1,269 packages were distributed among five temperature-controlled rooms that were set at 40°F (control-refrigerated conditions), 80°F, 100°F, 120°F, and 140°F (i.e., 486 samples/packages were stored at 40°F, 162 samples/packages were stored at 80°F, 216 samples/packages were stored at 100°F, 189 samples/packages were stored at 120°F and 216 samples/packages stored at 140°F). Physical and compositional attributes were evaluated during a 52-week storage period following the schedule shown in Table 16. Samples stored at 40°F (refrigerated control) were evaluated every time samples from another temperature were evaluated. At the end of each storage period (i.e., 8 weeks at 140°F, 14 weeks at 120°F, 36 weeks at 100°F and 52 weeks at 80°F) all temperatures were evaluated.

Table 16. Physical and compositional evaluation schedule

Date	Weeks	40°F Control	80°F 104 weeks (every 16 weeks)	100°F 42 weeks (every 6 weeks)	120°F 14 weeks (every 2 weeks)	140°F 8 weeks (every week)	NOTES
Nov 10	0	X					Start 2009
Nov 17	1	X				X	
Nov 24	2	X			X	X	
Dec 1	3	X				X	
Dec 8	4	X			X	X	
Dec 15	5	X				X	
Dec 22	6	X		X	X	X	
Dec 29	7	X				X	
Jan 5	8	X	(X)	(X)	X	X	End of 140°F 2010
Jan 12	9						
Jan 19	10	X			X		
Jan 26	11						
Feb 2	12	X		X	X		
Feb 9	13						
Feb 16	14	X	(X)	(X)	X		End of 120°F
Feb 23	15						
Mar 2	16	X	X				
Mar 9	17						
Mar 16	18	X		X			
Mar 23	19						
Mar 30	20						
Apr 6	21						
Apr 13	22						
Apr 20	23						
Apr 27	24	X		X			6 months
May 4	25						
May 11	26						
May 18	27						
May 25	28						
Jun 8	29						
Jun 15	30	X		X			
Jun 22	31						
Jun 29	32	X	X				
Jul 6	33						
Jul 13	34						
Jul 20	35						
Jul 27	36	X	X	X			End of 100°F

Table 16. Physical and Compositional Evaluation Schedule Cont'd

Date	Weeks	40°F Control	80°F 104 weeks (every 16 weeks)	100°F 42 weeks (every 6 weeks)	120°F 14 weeks (every 2 weeks)	140°F 8 weeks (every week)	NOTES
Aug 3	37						
Aug 10	38						
Aug 17	39						
Aug 24	40						
Aug 31	41						
Sep 7	42						
Sep 14	43						
Sep 21	44						
Sep 28	45						
Oct 5	46						
Oct 12	47						
Oct 19	48						
Oct 26	49						
Nov 2	50						
Nov 9	51						
Nov 16	52	X	X				12 months

Note: each (X) corresponds to three samples/packages per FSR item

2.2.3 Quality Evaluation

Physical quality attributes were evaluated for all nine items and composition was evaluated according to their major components. Changes in color, texture, water activity, moisture content, pH acidity, SSC, and sugar profile were measured in all nine FSR items. Physical and compositional evaluation is pictured in Figure 62. Ascorbic acid content was measured only in Bacon Cheddar Pocket Sandwich, Beef Snack Sweet BBQ, Apple Sauce CHO Enhanced, Italian Pocket Sandwich and BBQ Beef Pocket Sandwich. Lipid oxidation was evaluated in all items except in Applesauce.

2.2.3.1 Physical Evaluation

Color. Surface color measurements were taken on three replicated samples of each FSR sample per temperature, at five different points with a hand-held tristimulus reflectance colorimeter (Model CR-300, Minolta Co., Ltd., Osaka, Japan) equipped with a glass light-protection tube with an 8 mm aperture (CR-A33a, Minolta Co., Ltd., Osaka, Japan) using standard illuminant D65 (Figure 33). Color was recorded using the CIE-L*a*b* uniform color space (CIE-Lab), L* (lightness), a* (redness), and b* (yellowness) values. The numerical values of a* and b* were converted into hue angle ($h^{\circ}_{ab} = \tan^{-1}b^*/a^*$) and chroma ($C^*_{ab} = ((a^*)^2 + (b^*)^2)^{1/2}$).



Figure 62. Physical and compositional evaluation (from left to right: color and texture analysis, sample preparation, and soluble solids content measurements)

Texture. Textural analysis of each FSR sample per temperature was performed using the TA.XT Plus Texture Analyzer (Texture Technologies Corp., Scarsdale, NY) (Figure 62). Maximum peak force for compression and shear testing was expressed as kg-force (kgf).

Filled French Toast Pocket, Bacon Cheddar Pocket Sandwich, Wheat Snack Bread, BBQ Beef Pocket Sandwich, Italian Pocket Sandwich, and Chocolate Nut Dessert Bar were sheared using a knife probe for 25 mm at a speed of 10 mm/s with a 1 g contact force. Maximum peak force was obtained from five readings on each of the three replicated samples per temperature.

Textural analysis of Beef Snack, Sweet BBQ was performed using the TA.XT Plus Texture Analyzer (Texture Technologies Corp., Scarsdale, NY). Beef Snack, Sweet BBQ was sheared using a craft knife probe for 25 mm distance at a speed of 10 mm/s with a 1 g contact force. Maximum peak force was obtained from five readings on each of the three replicated samples per temperature.

Texture of applesauce was evaluated using a flat probe, which compressed 50 ml of applesauce in a 100 ml plastic container for 50 mm distance at a speed of 10 mm/s with a 1 g contact force. Maximum peak force was obtained by taking five readings on each of the three replicated samples per temperature.

Texture of tortillas was evaluated using a tortilla fixture with a cone type probe for 50 mm distance at a speed of 10 mm/s with a 1 g contact force. Maximum peak force was obtained from four readings of three replicates of each tortilla per temperature.

2.2.3.2 Compositional Analysis

Moisture Content:

Moisture content was determined by the standard gravimetric method. A 5 g homogenized sample was spread evenly over the bottom of a metal dish, weighed, and dried 24 h at 80°C in a laboratory oven (Model: 40GC, Quincy Lab Inc., Chicago, IL). Dry samples were cooled in desiccators then weighed and final weight was subtracted from initial weight to obtain the moisture content. Triplicates were taken from three FSR samples per temperature.

Water Activity:

Water activity was performed using the dew point technique with an AquaLab 4TE water activity meter (Decagon device Inc., WA, USA). A 2 g homogenized sample was weighed in a disposable plastic cup and placed into the chamber of the water activity meter for measurement. Three replicates per item per temperature were used.

Titrateable Acidity, Soluble Solids Content (SSC), and pH. Samples were homogenized using a hand-held homogenizer (BioMixerBamix, Biospec, Switzerland) or a commercial blender (Model HBB908, Hamilton Beach Inc., NC, USA). A 5 g aliquot of each sample was mixed thoroughly with 45 ml deionized water in a 50 ml polypropylene screw cap tube. After vortexing for 30 s, samples were centrifuged at 6500 rpm for 20 min in a centrifuge (Hermle Z200A, Labnet, Edison, NJ, USA). The supernatant was decanted from the centrifuge tubes for TA, SSC and pH measurements. Then 6.0 g of each supernatant was weighed into 50 ml beakers and diluted with 50 ml distilled water. The titrateable acidity was determined by titration with 0.1 N NaOH to an end point of pH 8.1 with an automatic titrimer (Titroline 96, SCHOTT-GERÄTE GmbH, Germany). The pH of samples was determined using a pH meter (Accumet model 15, Fisher Scientific, CO, USA), previously calibrated with a pH of 4 and 7. The soluble solids content (SSC) of the resulting clear samples was measured with a digital refractometer (Palette PR-101, 0-45 Brix, Atago Co. LTD, Tokyo) (Fig. 33).

Quantification of Ascorbic Acid (Vitamin C) by HPLC:

This procedure was only performed on samples that contained ascorbic acid, which included Applesauce, Bacon Cheddar Pocket Sandwich, Italian Pocket Sandwich, and BBQ Beef Pocket Sandwich. Samples were homogenized using a hand-held homogenizer (BioMixerBamix, Biospec, Switzerland) or a commercial blender (Model HBB908, Hamilton Beach Inc., NC, USA). Then 2 g of each homogenized sample was weighed into a 50 ml plastic bottle and 20 ml metaphosphoric acid mixture (6% HPO₃, containing 2 N acetic acid) was added. The samples were filtered (0.22 µm filter) prior to HPLC analysis. Ascorbic acid analysis was conducted using a Hitachi LaChromUltra UHPLC system with a diode array detector and a LaChromUltra C18 4.6µm column (2 × 50 mm) (Hitachi, Ltd., Tokyo, Japan). The analysis was performed under isocratic mode at a flow rate of 1 ml/min with a detection of 254 nm. Sample injection volume was 5 µL. The mobile phase used was buffered potassium phosphate monobasic (KH₂PO₄, 0.5%, w/v) at pH 2.5, with metaphosphoric acid (HPO₃, 0.1%, w/v). The retention time of ascorbic acid peak was 2.48 min. After comparison of retention time with the ascorbic acid standards,

the peak was identified. The amount of total ascorbic acid was quantified using calibration curves obtained from different concentrations of ascorbic acid standards. Three samples per item per temperature were used for each time with duplicate HPLC injections.

Quantification of Individual and Total Sugar Profile by HPLC:

This procedure was the same for all FSR samples except for Applesauce, for which the ether and boiling steps were omitted. The procedure for Applesauce samples can be found in the second paragraph below.

An aliquot of 5 g from each homogenized sample was mixed thoroughly with 45 ml petroleum ether in a 50 ml polypropylene screw cap tube. After vortex for 30 s, samples were centrifuged at 6000 rpm for 10 min. The ether was discarded and 45 ml distilled water was added. The samples were placed into a boiling water bath for 25 min, and vortex every 5-7 min. Subsequently, the samples are cooled to room temperature and centrifuged at 6000 rpm for 10 min. The supernatant was decanted from the centrifuge tubes and filtered through 0.45 μ m nylon syringe into labeled amber glass vials. Individual and total sugar analyses were conducted using a Hitachi HPLC system with a RI-refractive index detector and a 300 mm \times 8 mm Shodex SP0810 column (Shodex, Colorado Springs, CO) with a SP-G guard column (2 mm \times 4 mm). An isocratic solvent delivery of water was run at 1.0 ml/min. Sample injection volume was 5 μ L. Several standards including maltodextrin, lactose, sucrose, glucose, and fructose were run to identify sample peaks. After comparison of retention time with standards, the peaks were identified. The amount of total sugar was quantified using calibration curves obtained from different concentration of standards. Three samples per FSR item per temperature were used for each time with duplicate HPLC injections.

An aliquot of 5 g per Applesauce sample was mixed thoroughly with 45 ml distilled water in a 50 ml polypropylene screw cap tube. After vortex or mixing for 30 s, samples were centrifuged at 6000 rpm for 10 min. The supernatant was decanted from the centrifuge tubes and filtered through 0.45 μ m nylon syringe into labeled amber glass vials. Individual and total sugar analyses were conducted using a Hitachi HPLC system with a RI-refractive index detector and a 300 mm \times 8 mm Shodex SP0810 column (Shodex, Colorado Springs, CO) with a SP-G guard column (2 mm \times 4 mm). An isocratic solvent delivery of water was run at 1.0 ml/min. Sample injection volume was 5 μ L. Several standards including maltodextrin, lactose, sucrose, glucose, and fructose were run to identify sample peaks. After comparison of retention time with the standards, the peaks were identified. The amount of total sugar was quantified using calibration curves obtained from different concentration of standards. Three samples per Applesauce item per temperature were used for each time with duplicate HPLC injections.

Lipid Oxidation. Lipid oxidation was determined for all FSR samples except for Applesauce samples, which had practically no lipid content. The Peroxide Value (PV) method was used to measure the primary oxidation products and an index to quantify the amount of hydrogen peroxide in FSR products. Approximately 1 g of each homogenized item was transferred to a 15 ml disposable glass test tube, homogenized for 1 min with 3ml of chloroform/methanol (2:1) using a Biohomogenizer and 7 ml of chloroform/methanol (2:1) was added and mixed with 3 ml

of 0.5 % NaCl solution. The mixture was vortex for 30 s and then centrifuged at 2000 rpm for ten minutes in a cold room at 5°C. The chloroform phase was removed, and a 2 ml volume was made to 10 ml using chloroform/methanol (2:1). A 50 µl aliquot of thiocyanate/Fe²⁺ solution was added then the sample was inverted three times with parafilm. The thiocyanate/Fe²⁺ solution was made immediately before use by mixing 1 volume of thiocyanate solution (3.94 M ammonium thiocyanate) with 1 volume of Fe²⁺ solution (obtained from the supernatant of a mixture of 3 ml of 0.144 M BaCl₂ in 0.4 M HCl and 3 ml of freshly prepared 0.144 M FeSO₄). The samples were incubated for 10 min at room temperature, and the absorbance was measured at 500 nm. A standard curve was prepared using cumenehydroperoxide.

Although there is no certain threshold for PV in the literature, some researchers have reported the level of PV depending on the type of food analyzed. For example, the limiting PV values reported to be critical for acceptability of roasted peanuts or peanut oil were 20-30 meq/kg (Evrantz, 1993; St. Angelo et al., 1977; Balasubramanyam et al., 1983; Narasimhan et al., 1986); crude fish oil was 7–8 meq /kg (Huss, 1988); bread sticks were 11.4-14.2 meq/kg (Calligaris, 2008); and biscuits were 13-18 meq/kg (Calligaris, 2007).

2.3 Results

2.3.1 Filled French Toast Pocket

2.3.1.1 *Physical Characteristics*

Color:

The color parameters shown in Figure 63 are defined as L*value, hue angle, and chroma value. The samples exposed to high temperatures (120°F and 140°F) after 8 weeks, showed a sharp decrease in L* value, chroma, and hue angle, and mainly for samples stored at 140°F (Figure 34) For example, L* value, chroma, and hue angle of samples stored at 140°F showed 40%, 32% and 20% decreases, respectively. In general, as the storage temperature increased, the visual color of the samples became darker brown (Figure 64). Brown color development took place after an 8-week storage period for samples stored at 120 and 140°F and was aggravated by time and temperature exposure. The reaction that caused the color change could have been caused by non-enzymatic browning as a result of exposure to extreme temperatures.

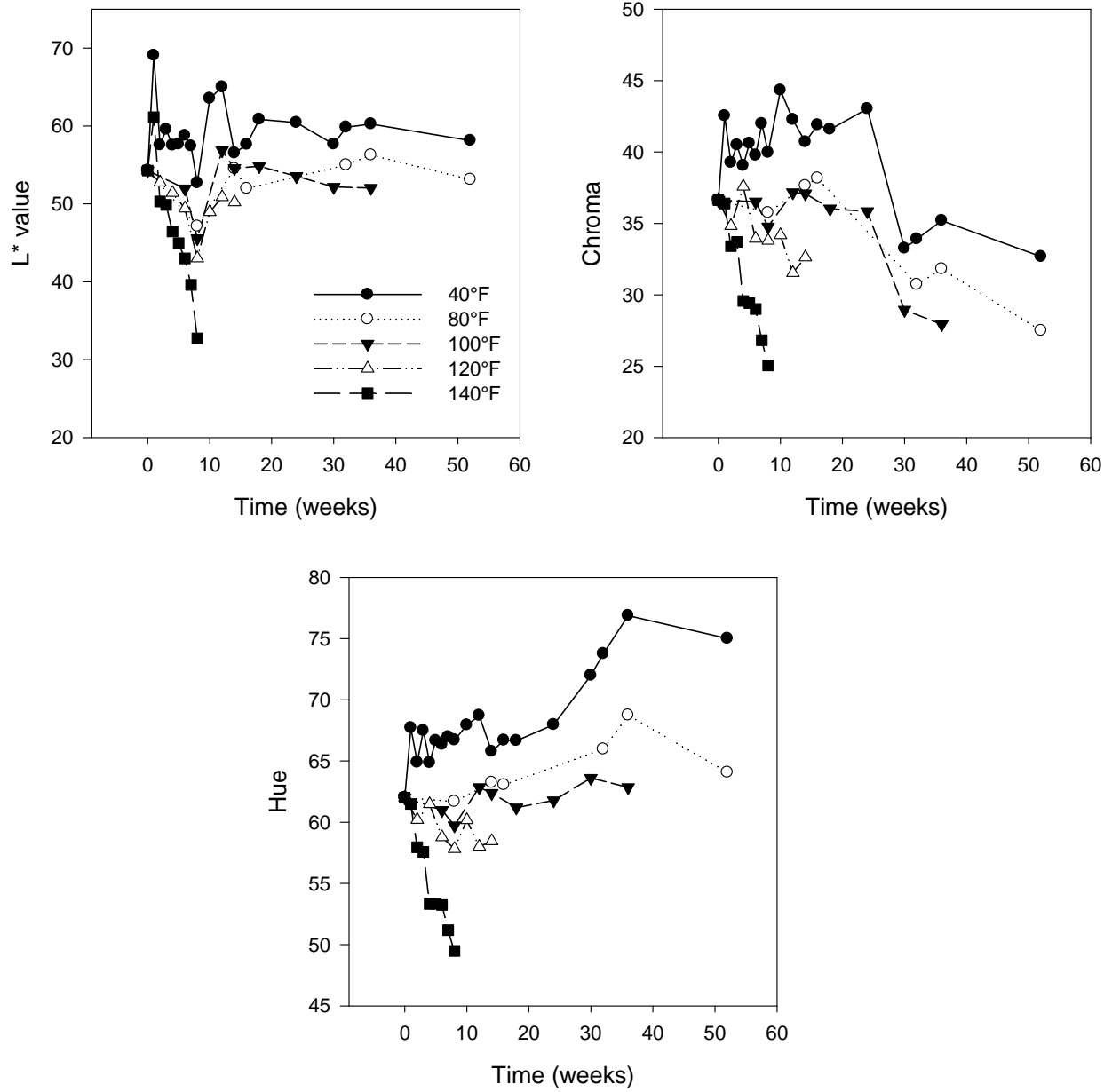

Figure 63. Changes in color attributes (L*, chroma, and hue) of Filled French Toast Pocket during a 52-week storage period at 40, 80, 100, 120, and 140°F

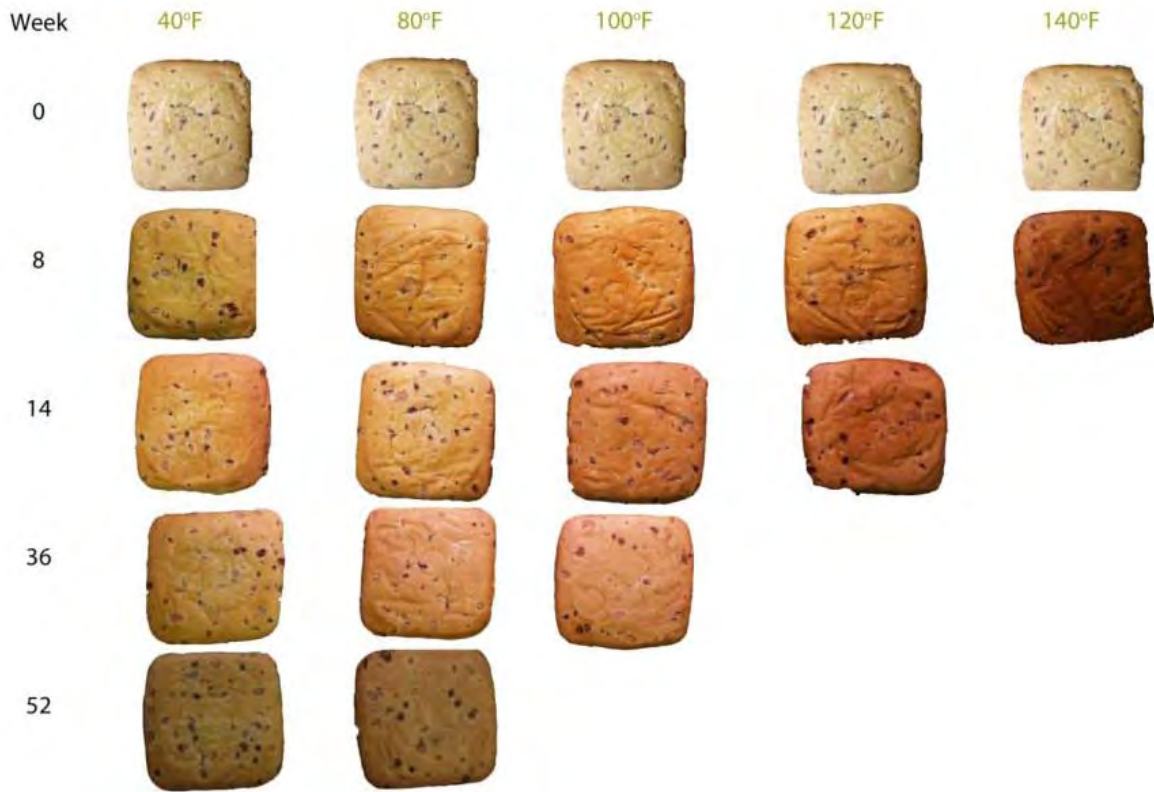

Figure 64. Changes in the appearance of Filled French Toast Pocket during a 52-week storage period at 40, 80, 100, 120, and 140°F

Texture:

The major effect of temperature on the texture of Filled French Toast Pocket was observed after storage for 8 weeks at 100, 120 and 140°F; overall, firmness significantly decreased in samples store at temperatures higher than 80°F (Figure 65). After a 52-week storage period, samples stored at 40°F and 80°F showed only slight changes in their texture when compared to their initial texture values.

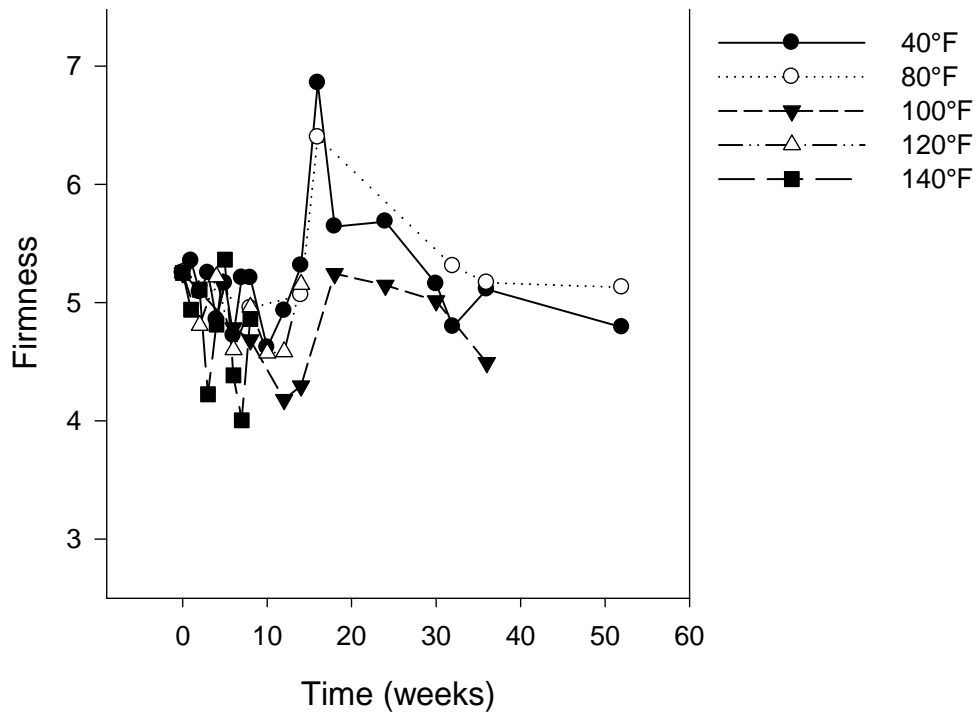

Figure 65. Changes in the texture of Filled French Toast Pocket during a 52-week storage period at 40, 80, 100, 120, and 140°F

2.3.1.2 Compositional Analysis

Titratable Acidity, Soluble Solids Content, and pH:

The pH of Filled French Toast Pocket showed a decreasing trend (Figure 66). During a 36-week storage period, pH decreased for all storage temperatures, but the pH of samples stored at higher temperatures decreased rapidly, especially for samples stored for 8 weeks at 140°F. There were no major changes in titratable acidity regardless of the storage temperature or exposure time (Figure 66). During a 36-week storage period the soluble solids content of the samples fluctuated regardless of the temperatures.

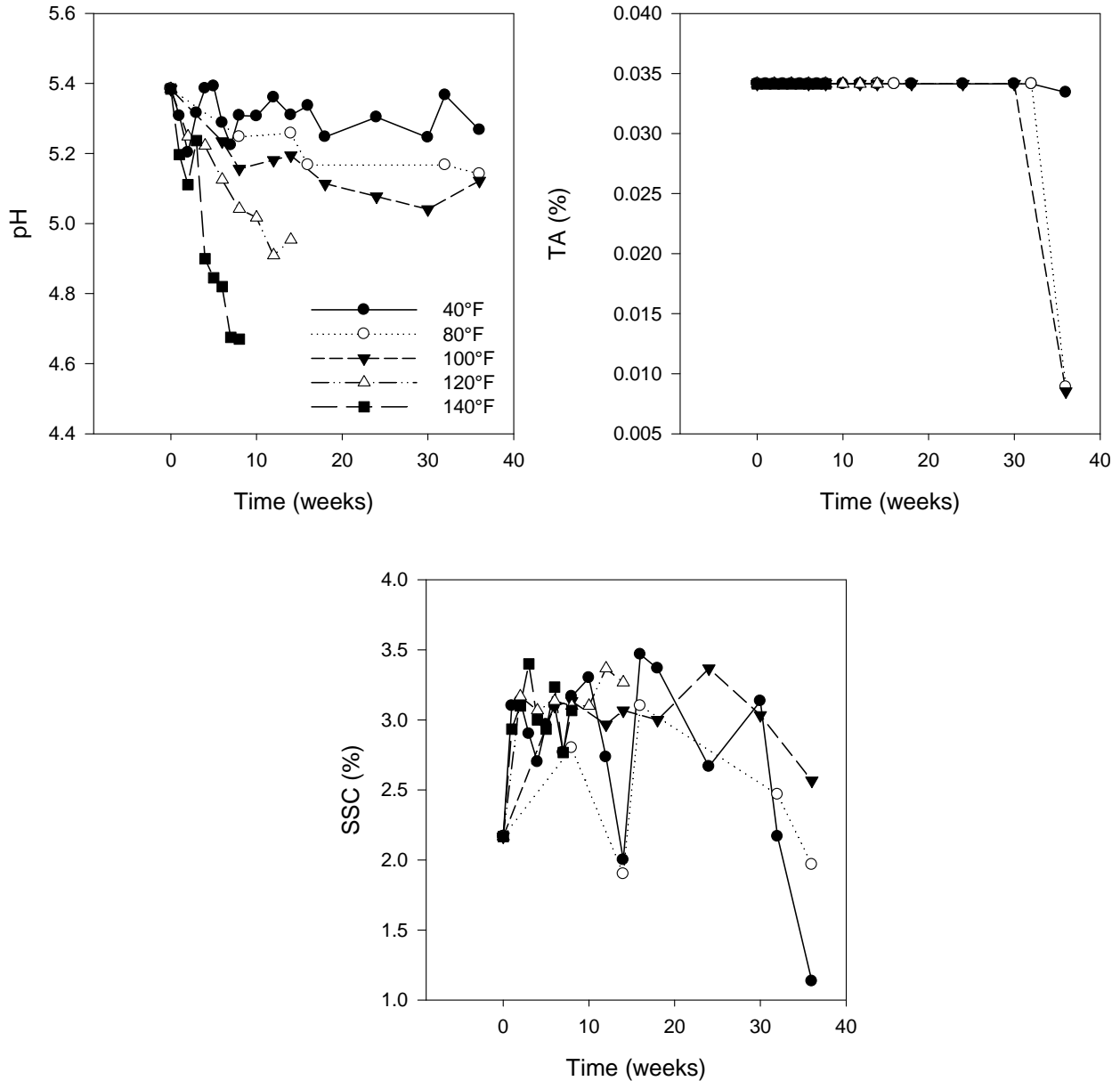

Figure 66. Changes in pH, titratable acidity, and soluble solid contents of Filled French Toast Pocket during a 36-week storage period at 40, 80, 100, 120, and 140°F

Water Activity and Moisture Content:

Water activity increased during storage regardless of temperature; however, sample stored at 140°F experienced the lowest water activity and had the lowest moisture content compared to the other storage temperatures (Figure 67). After 52 weeks of storage, samples stored at 40 and 80°F did not show any major change in moisture content compared to initial measurement.

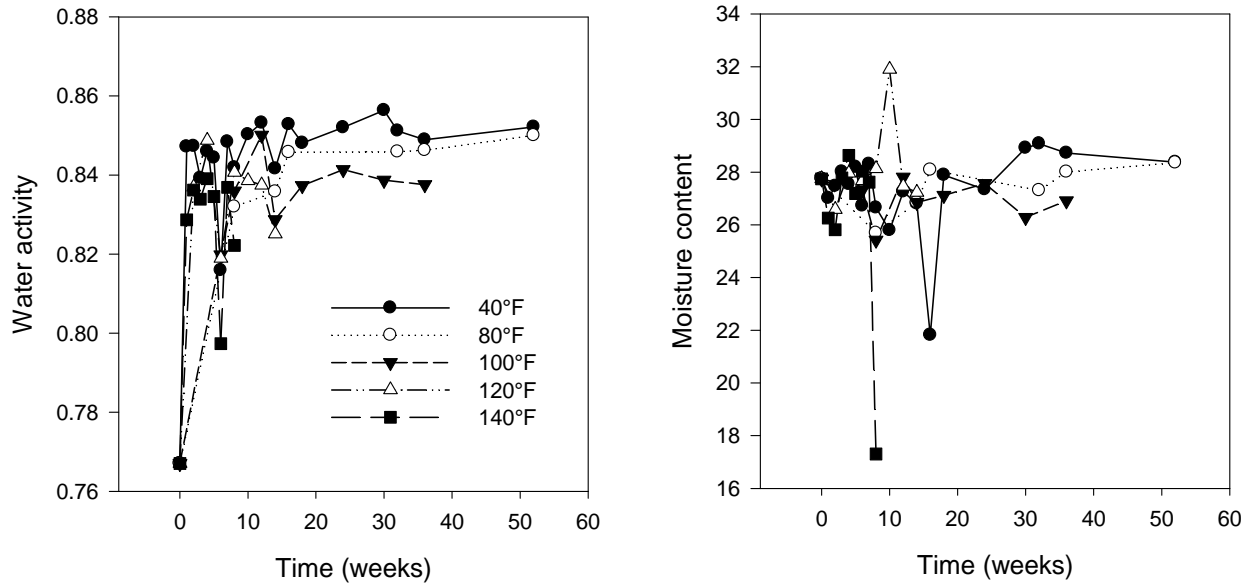

Figure 67. Changes in moisture content and water activity of Filled French Toast Pocket during a 52-week storage period at 40, 80, 100, 120, and 140°F.

Individual and Total Sugar Profiles:

Sucrose was the major sugar measured in Filled French Toast Pocket (Figure 68). While sucrose concentration decreased, the glucose and fructose concentration increased for samples stored at 100°F or higher temperatures. Exposure to high temperatures resulted in hydrolysis of sucrose into fructose and glucose (Figure 68). However, the total sugar concentration of Filled French Toast Pocket stored at 140°F had a higher value than the other temperatures. This could have been caused by the concentration effect on total sugar contents due to water loss during storage at high temperature.

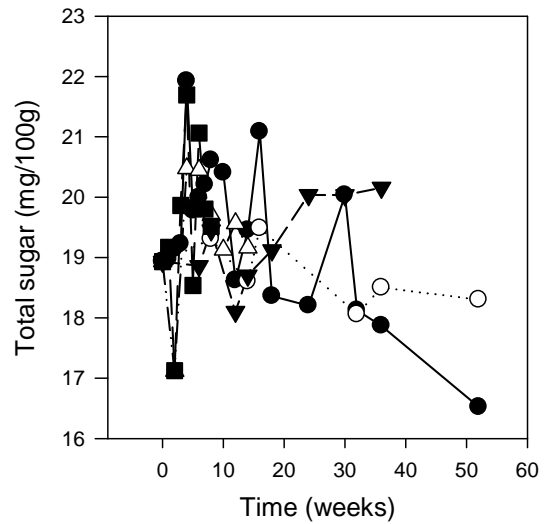
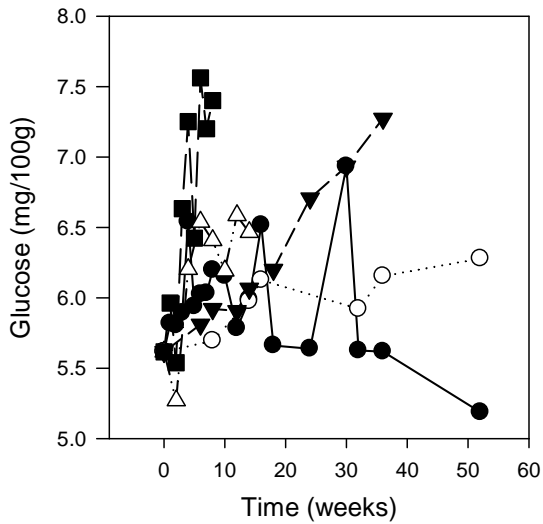
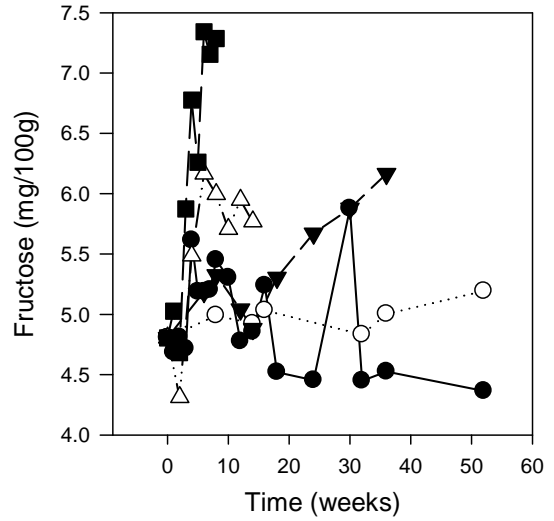
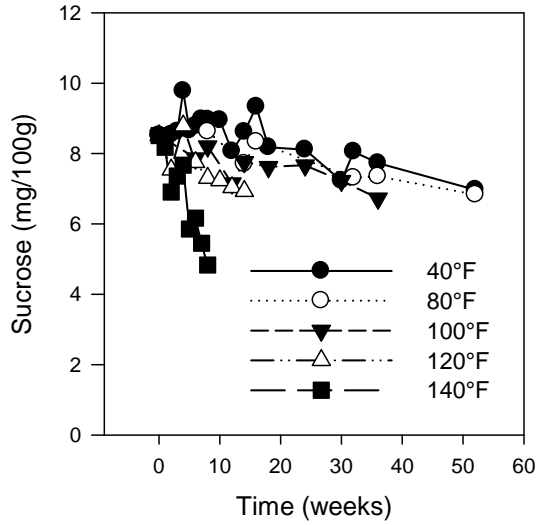

Figure 68. Changes in sugar profiles of Filled French Toast Pocket during a 52-week storage period at 40, 80, 100, 120, and 140°F

Changes in the amount of maltodextrin for Filled French Toast Pocket during 52 weeks storage at 40, 80, 100, 120, and 140°F are shown in Figure 69. Maltodextrin concentration fluctuated for all temperatures regardless of storage time. In addition, there was no significant difference between the maltodextrin content of samples stored at 40 and 80°F after 52 weeks.

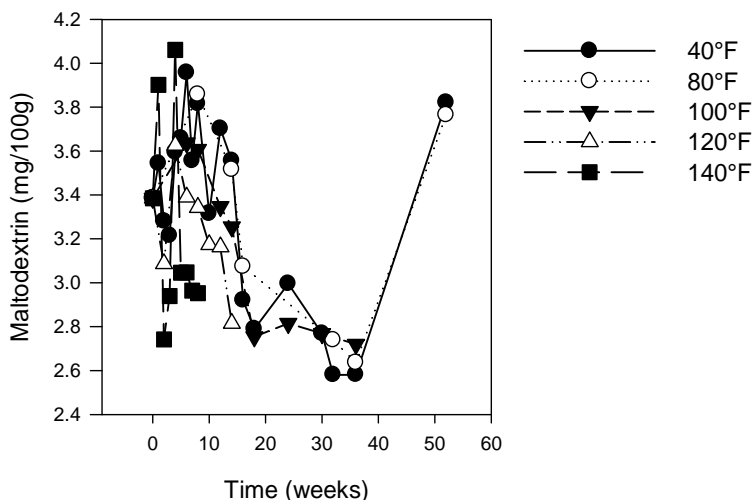

Figure 69. Changes in maltodextrin content of Filled French Toast Pocket during a 52-week storage period at 40, 80, 100, 120, and 140°F

Lipid Oxidation:

The degree of lipid oxidation was measured using peroxide value (PV) assay to monitor the primary oxidation products formed. Figure 70 shows the level of peroxide value in Filled French Toast Pocket during 52 weeks of storage at 40, 80, 100, 120, and 140°F. The level of lipid oxidation was reasonably low for all temperatures after 52 weeks storage. The degree of lipid oxidation fluctuated regardless of the storage time and temperature. In terms of overall quality, the lipid oxidation that occurred during storage of Filled French Toast Pocket was not considered critical as the levels were maintained low, considering a range of 7-30 meq/kg as the limit of acceptability reported in the literature for different foods (in *Materials and Methods*).

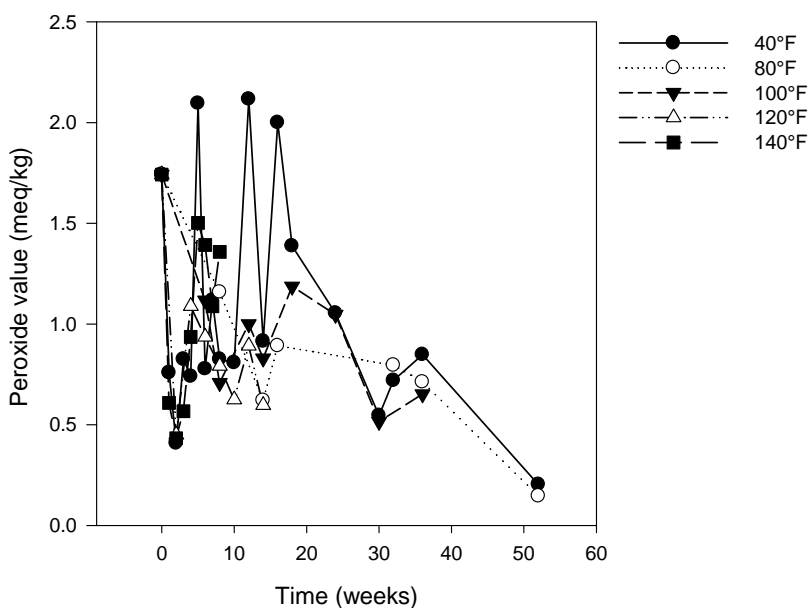

Figure 70. Changes in peroxide value of Filled French Toast Pocket during a 52-week storage period at 40, 80, 100, 120, and 140°F

2.3.2 Bacon Cheddar Pocket Sandwich

2.3.2.1 Physical Characteristics

Color:

Development of brown color on Bacon Cheddar Pocket Sandwich was faster in samples stored at 140°F as compared to samples stored at lower temperatures. L* values, hue angle, and chroma values decreased as temperature increased but slightly changed for samples stored at 80°F and at 40°F (Figure 71). Exposure to extreme temperatures (120 and 140°F) during storage contributed to a considerable decreased in L* value, hue angle, and chroma values when compared to the other temperatures. As the temperature level increased, the Bacon Cheddar Pocket Sandwich developed a darker brown color appearance (Figure 72). Overall, development of browning occurred after 8 weeks of storage at 120°F and 140°F and was intensified with exposure time and temperature. The development of brown color could have been due to non-enzymatic browning caused by exposure to high temperature during storage.

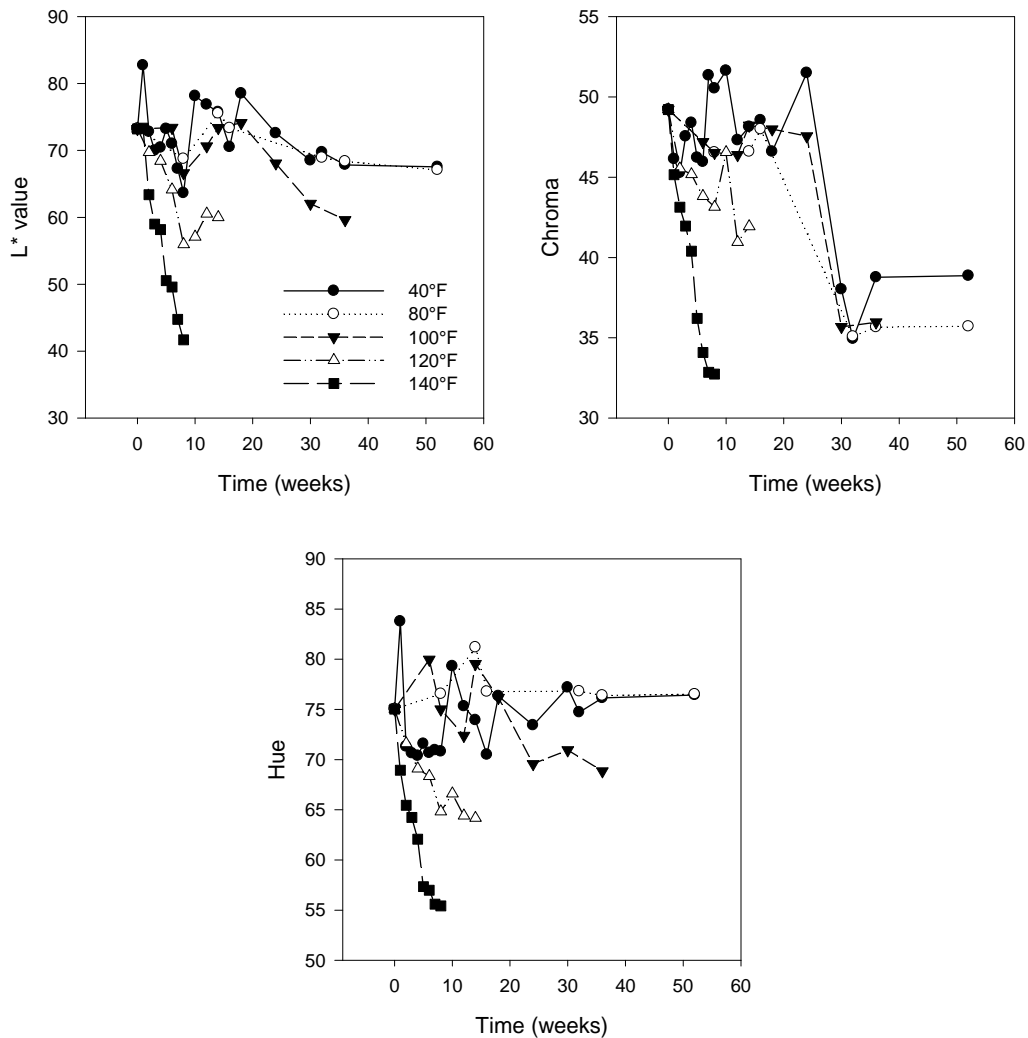

Figure 71. Changes in the color attributes (L*, chroma, and hue) of Bacon Cheddar Pocket Sandwich during a 52-week storage period 40, 80, 100, 120, and 140°F



Figure 72. Changes in the appearance of Bacon Cheddar Pocket Sandwich during a 52-week storage period at 40, 80, 100, 120, and 140°F

Texture:

The most important effect of temperature was seen on the firmness of samples stored at 100°F and higher temperatures as shown by a sharp decrease toward the end of 8-12 weeks storage period (Figure 73). However, at the end of 52 weeks, samples stored at 40 and 80°F had minimum changes in their firmness compared to initial values before storage.

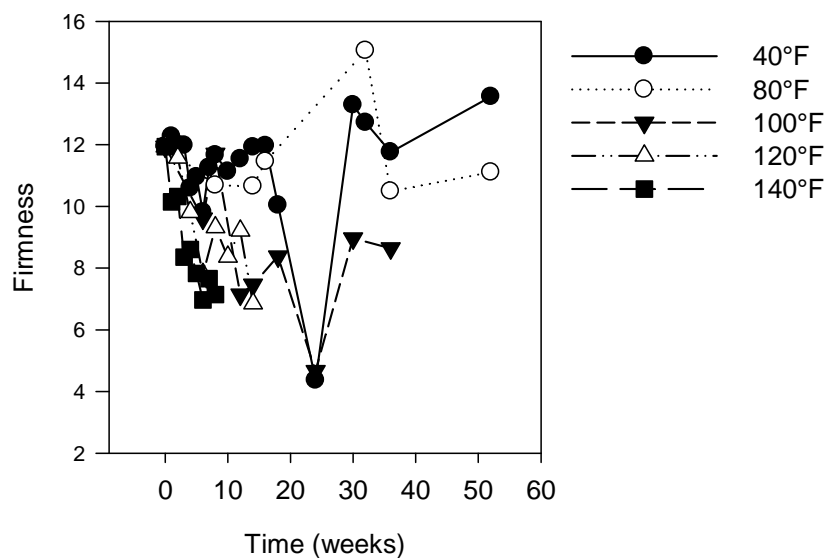

Figure 73. Changes in the texture of Bacon Cheddar Pocket Sandwich during a 52-week storage period at 40, 80, 100, 120, and 140°F

2.3.2.2 Compositional Analysis

Titrateable Acidity, Soluble Solids Content, and pH:

Overall, pH of Bacon Cheddar Pocket Sandwich showed a decreasing trend (Figure 74); on the other hand, titrateable acidity showed an increasing trend during storage, regardless of the storage temperature. The pH slightly decreased for all storage temperatures during 36 weeks of storage, but samples stored at higher temperatures decreased rapidly after 8 weeks of storage, primarily for sample stored at 140°F. Titrateable acidity increased over time for all samples, but the increase in acidity intensified as storage temperature increased. There was no major change in soluble solid contents, regardless of the storage temperature and exposure time (Figure 74).

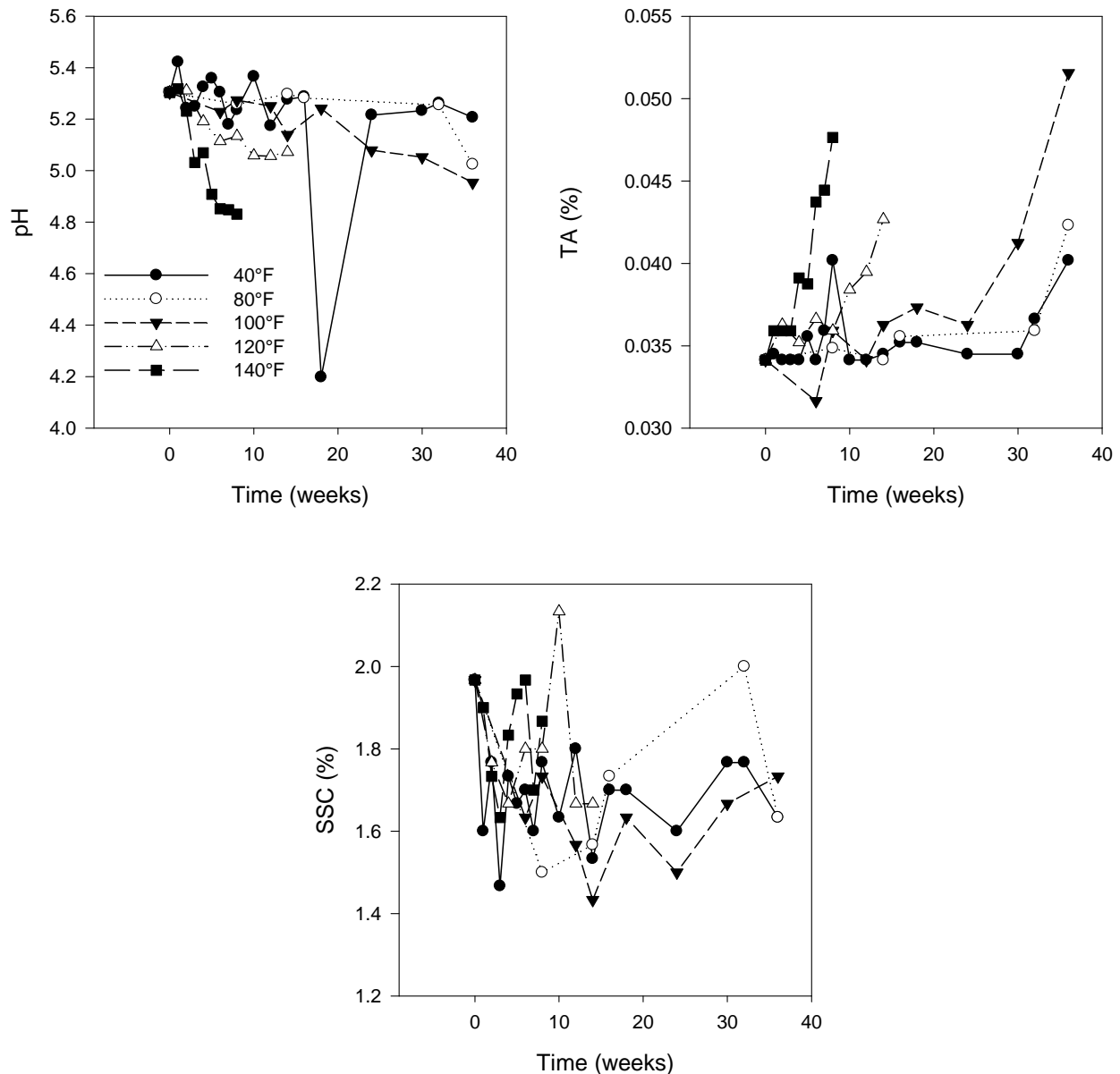

Figure 74. Changes in pH, titrateable acidity, and soluble solid contents of Bacon Cheddar Pocket Sandwich during a 36-week storage period at 40, 80, 100, 120, and 140°F

Water Activity and Moisture Content:

Changes in water activity and moisture content for Bacon Cheddar Pocket Sandwich stored at different temperatures are shown in Figure 75. Water activity and moisture content fluctuated regardless of the storage time or temperature. Overall, exposure to high temperatures (120 and 140°F) resulted in lower water activity and moisture content compared to other temperatures. However, after week 18 and week 24, samples stored at 80 and 100°F showed high water activity and moisture content compared to initial values.

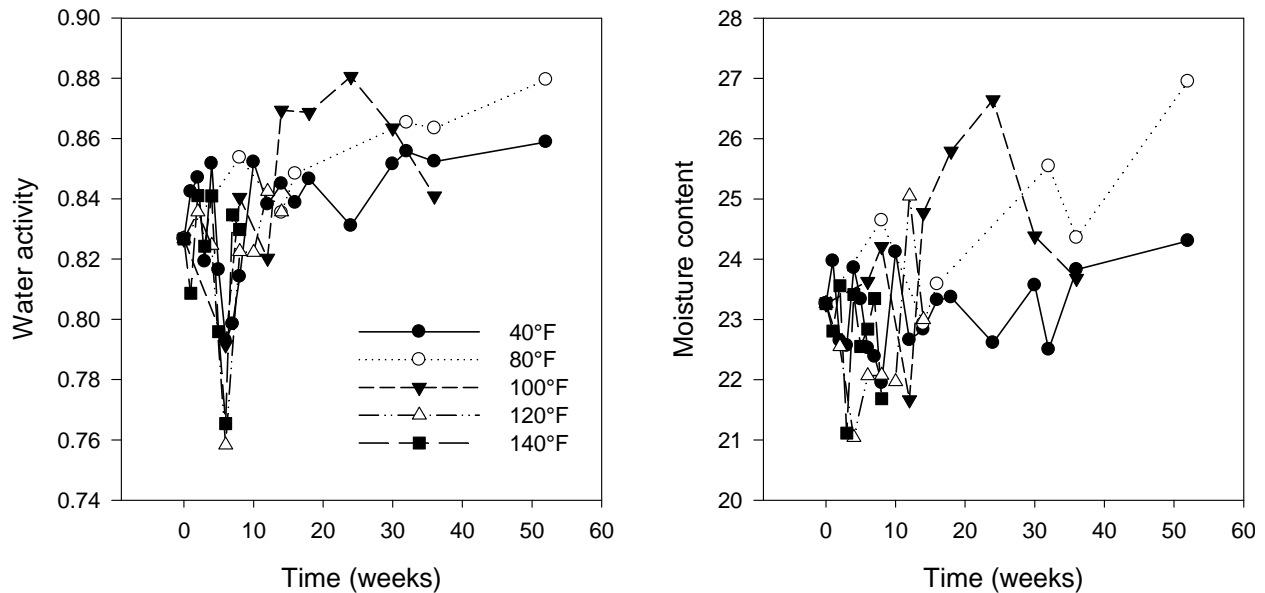

Figure 75. Changes in moisture content and water activity of Bacon Cheddar Pocket Sandwich during a 52-week storage period at 40, 80, 100, 120, and 140°F

Ascorbic Acid Content:

Ascorbic acid content in Bacon Cheddar Pocket Sandwich was quantified by using a high performance liquid chromatography. Ascorbic acid content of samples decreased sharply after approximately 20 week of storage, regardless of the storage temperature; after approximately 30 weeks, ascorbic acid content increased but then decreased again (Figure 76).

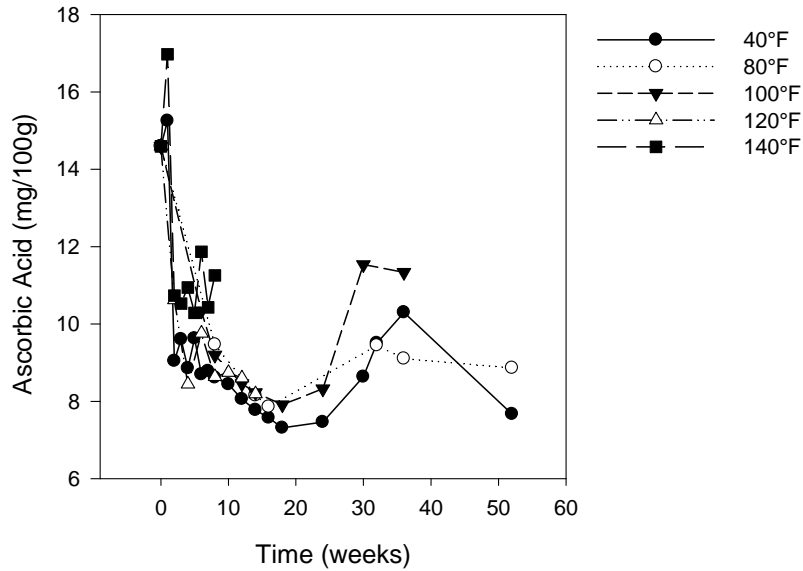

Figure 76. Changes in the ascorbic acid content of Bacon Cheddar Pocket Sandwich during a 52-week storage period at 40, 80, 100, 120, and 140°F

Individual and Total Sugar Profiles:

Figure 77 shows changes in sucrose, fructose, glucose, and total sugar contents for Bacon Cheddar Pocket Sandwich during 52 weeks storage at 40, 80, 100, 120, and 140°F. There was a clear decrease in the concentrations of sucrose, glucose, and total sugar contents for samples stored at temperatures higher than 80°F. This could have been caused by the degradation of sugars when samples were exposed to high temperatures for an 8-week storage period. The samples stored at lower temperatures showed minimum changes in sugar content after a 36 weeks storage period, but began to show reduced sugar content thereafter.

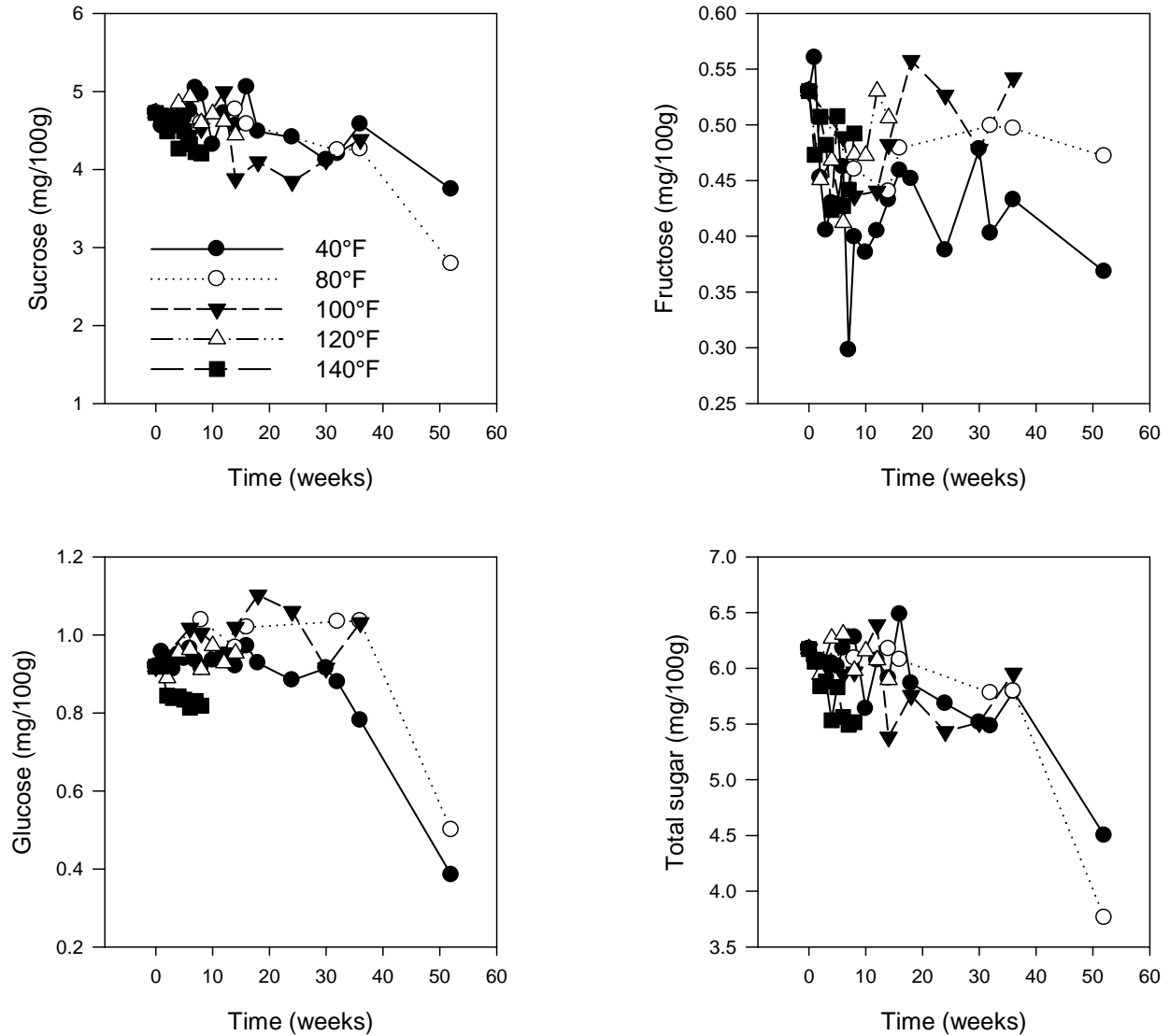

Figure 77. Changes in the sugar profiles (sucrose, glucose, fructose, and total sugar) of Bacon Cheddar Pocket Sandwich during a 52-week storage period at 40, 80, 100, 120, and 140°F

The amount of maltodextrin decreased with an increase in storage temperature particularly in samples stored at 120 and 140°F (Figure 78). There were no major changes in maltodextrin concentration for the samples stored at the other temperatures after 36 weeks of storage period. However, after 52 weeks storage at 40 and 80°F the amount of maltodextrin increased.

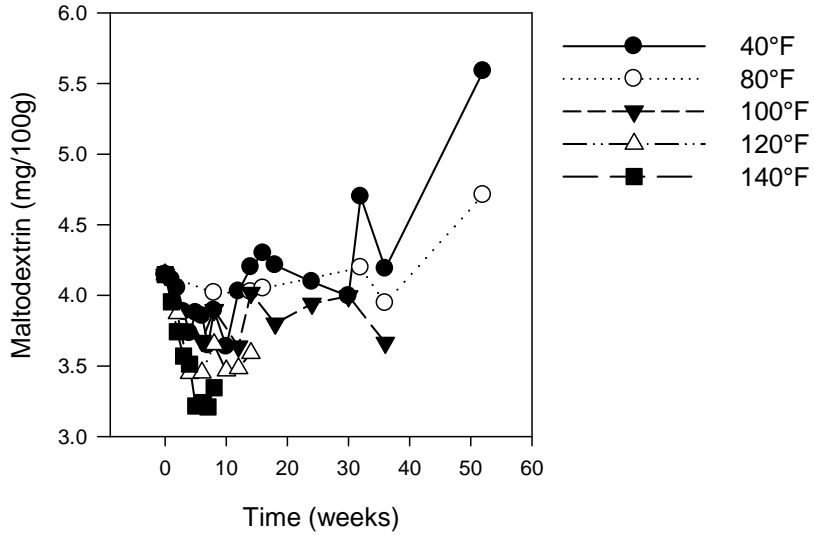

Figure 78. Changes in the maltodextrin content of Bacon Cheddar Pocket Sandwich during a 52-week storage period at 40, 80, 100, 120, and 140°F

Lipid Oxidation:

Peroxide value was measured on both whole sandwich (bread and meat) and meat only, during 52 weeks storage at 40, 80, 100, 120, and 140°F (Figure 79). The level of lipid oxidation was reasonably low for all temperatures after 52 weeks storage. In terms of overall quality, the lipid oxidation that occurred during storage of Bacon Cheddar Pocket Sandwich was not considered critical as the levels remained low, considering a range of 7-30 meq/kg as the limit of acceptability reported in the literature for different foods (in Materials and Methods).

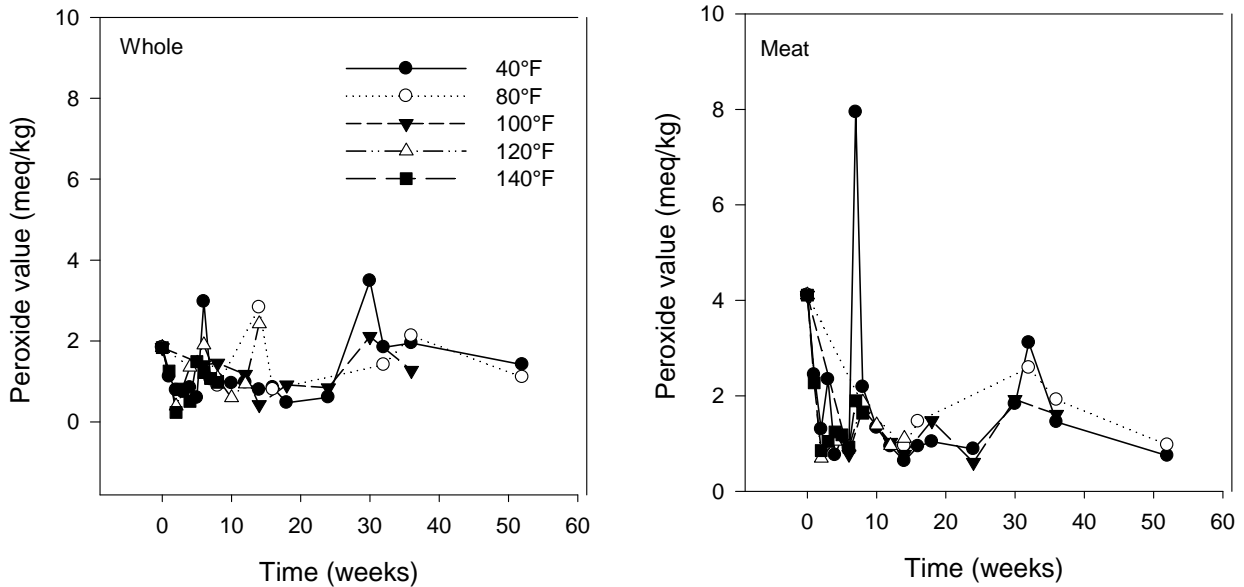

Figure 79. Changes in the peroxide value of the whole sandwich and in the meat only of Bacon Cheddar Pocket Sandwich stored for a 52-week storage period at 40, 80, 100, 120, and 140°F

2.3.3 Wheat Snack Bread

2.3.3.1 Physical Characteristics

Color:

Exposure of Wheat Snack Bread to high temperature (120 and 140°F) resulted in a sharp decrease of L* value, hue angle, and chroma value (Figure 80). These changes were shown visually by the development of dark brown appearance of the bread slices (Figure 81). Brown color development took place after 8 weeks of storage at 120 and 140°F and was intensified by exposure time and temperature. The reaction that occurred resulting in the development of brown discoloration could have been caused by non-enzymatic browning reactions as a result of exposure to high temperatures. Conversely, there was no major change in L* value and hue angle for samples stored at 40 and 80°F compared to their initial value before storage.

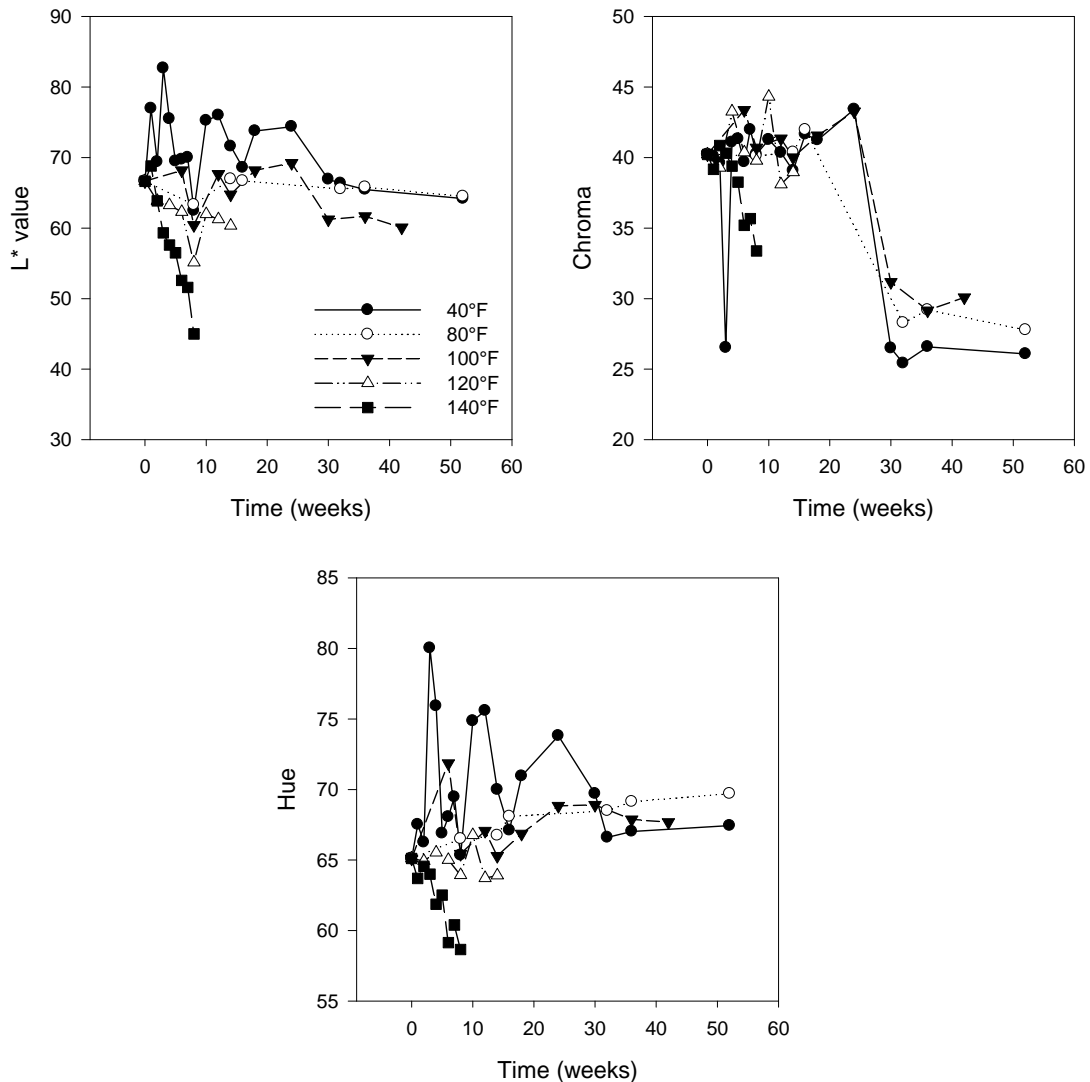

Figure 80. Changes in the color attributes (L*, chroma, and hue) of Wheat Snack Bread during a 52-week period at 40, 80, 100, 120, and 140°F

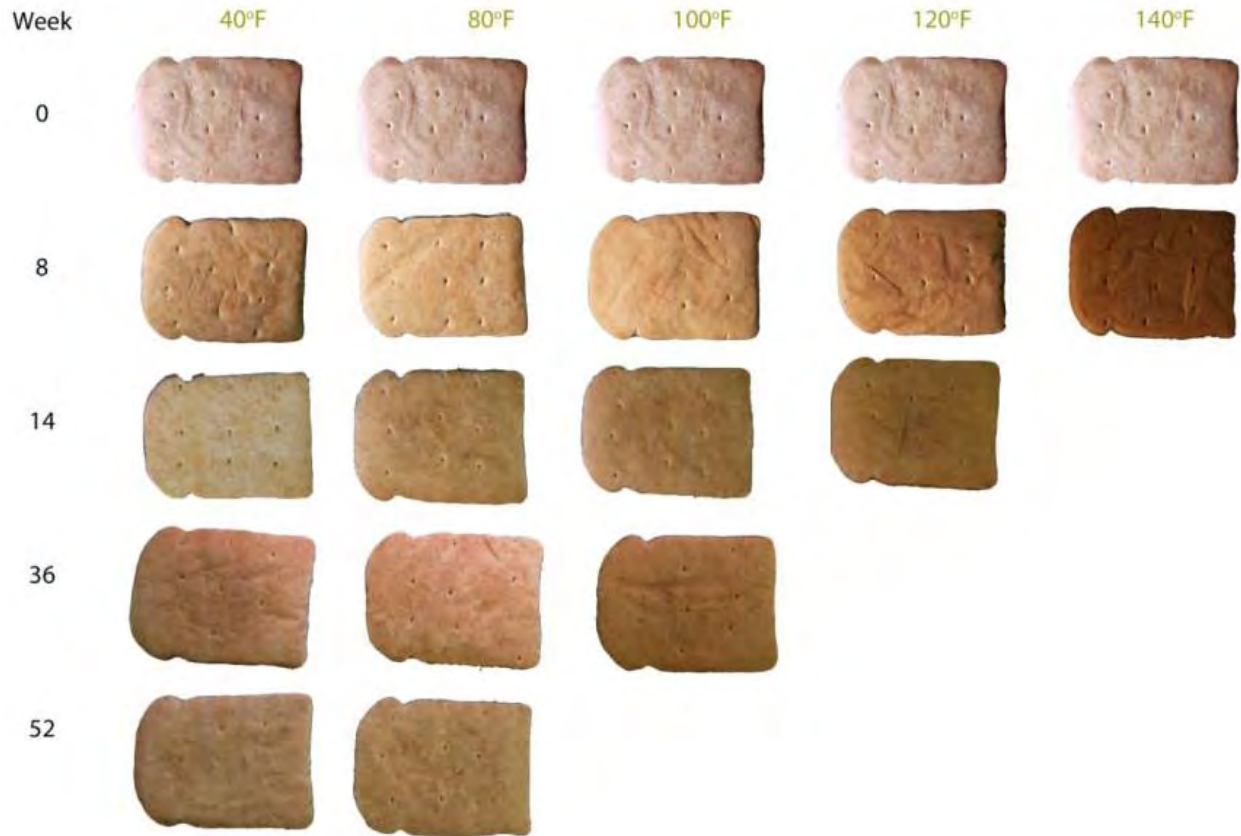

Figure 81. Changes in the appearance of Wheat Snack Bread during a 52-week storage period at 40, 80, 100, 120, and 140°F

Texture:

The most important effect of exposure to high temperature was seen on the texture of samples stored at 120°F or above by the fast increase in firmness value towards to the end of an 8 week storage period (Figure 82). However, after 52 weeks samples stored at 40 and 80°F had a slighter change in texture compared to initial measurement or compared to samples stored at higher temperatures.

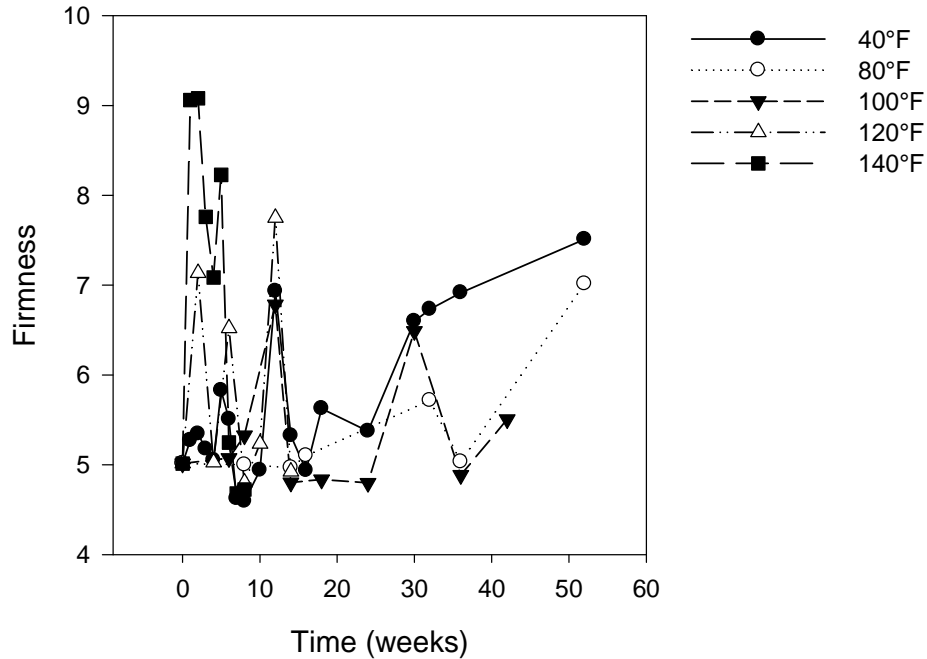

Figure 82. Changes in the texture of Wheat Snack Bread during a 52-week storage period at 40, 80, 100, 120, and 140°F

2.3.3.2 Compositional Analysis

Titratable Acidity, Soluble Solids Content, and pH:

Changes in pH, titratable acidity, and soluble solids content of Wheat Snack Bread during 52 weeks storage period at different temperatures (40, 80, 100, 120, and 140°F) are shown in Figure 83. The pH of bread samples decreased as the storage temperature increased. Samples stored at high temperatures (120 and 140°F) showed a rapid decrease in pH, especially after storage of 8 weeks for samples stored at 140°F. There were no noticeable pH changes in the samples stored at 40 and 80°F. However, there was no significant difference in titratable acidity of the bread samples, regardless of storage time or temperature. Soluble solids content of the samples fluctuated, regardless the temperature, but after 8 weeks of storage it increased and then decreased to reach levels similar to those measured before storage.

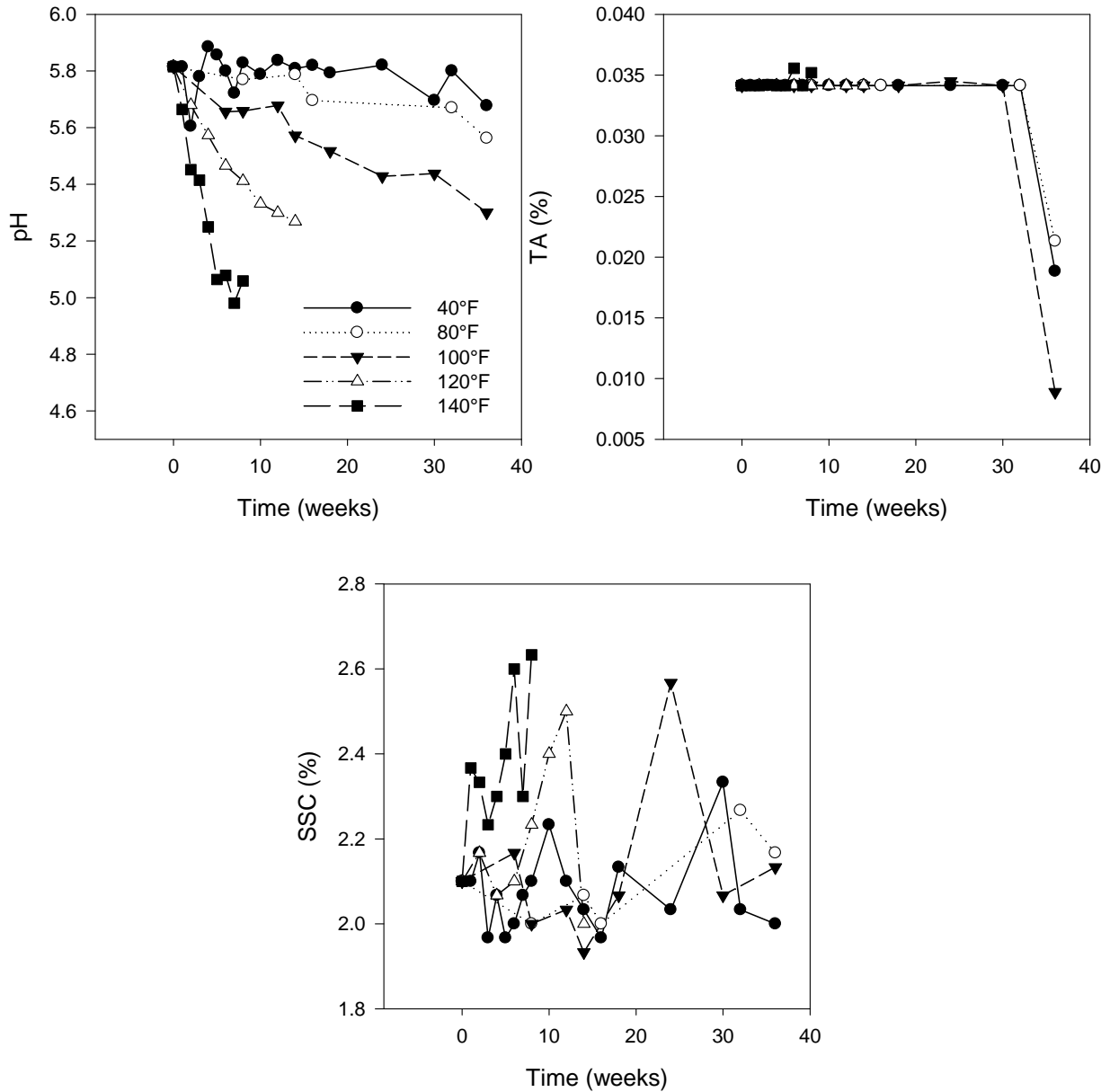

Figure 83. Changes in the titratable acidity, soluble solids content, and pH of Wheat Snack Bread during a 36-week storage period at 40, 80, 100, 120, and 140°F

Water Activity and Moisture Content:

When storage temperature increased, the water activity in Wheat Snack Bread started to increase, becoming stable after 12 weeks of storage (Figure 84). Moisture content decreased after approximately 8 weeks of storage, regardless of storage time and temperatures, increasing thereafter to attain levels compared to those measured initially. Samples stored at 40 and 80°F for 52 weeks did not show major changes in moisture content compared to initial measurements (Figure 84).

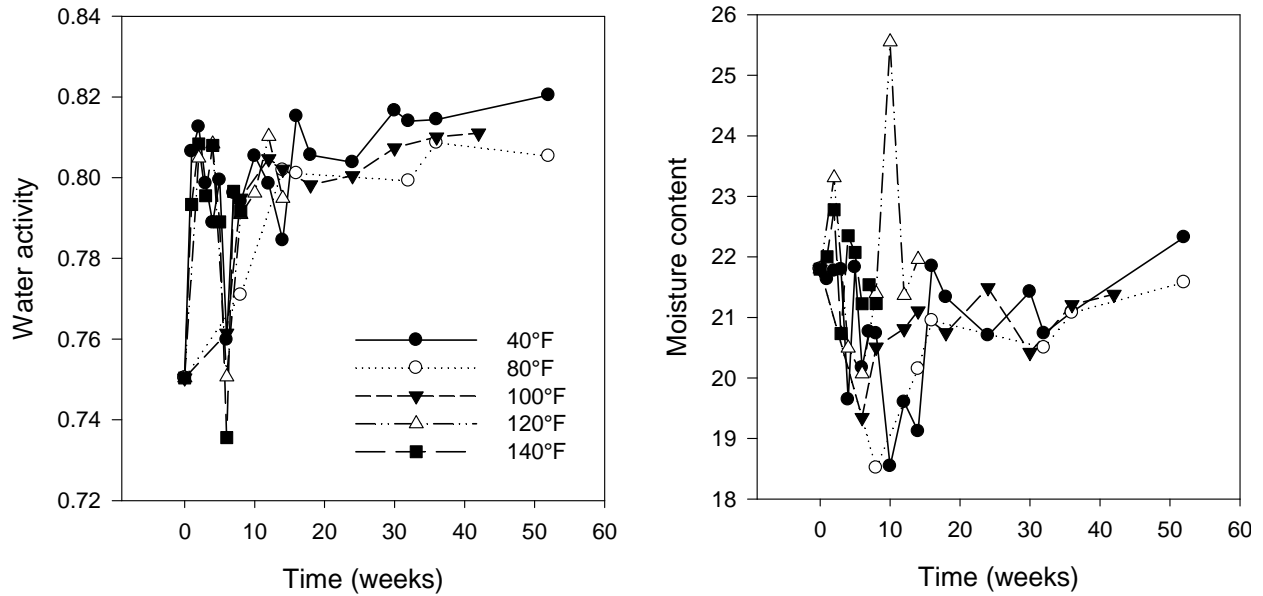

Figure 84. Changes in moisture content and water activity of Wheat Snack Bread during storage for a 52-week period at 40, 80, 100, 120, and 140°F

Individual and Total Sugar Profiles:

After 24 weeks of storage, the amount of sucrose and total sugar increased and thereafter decreased, regardless of the storage temperature, while the amount of fructose and glucose decreased continuously during the entire storage period (Figure 85).

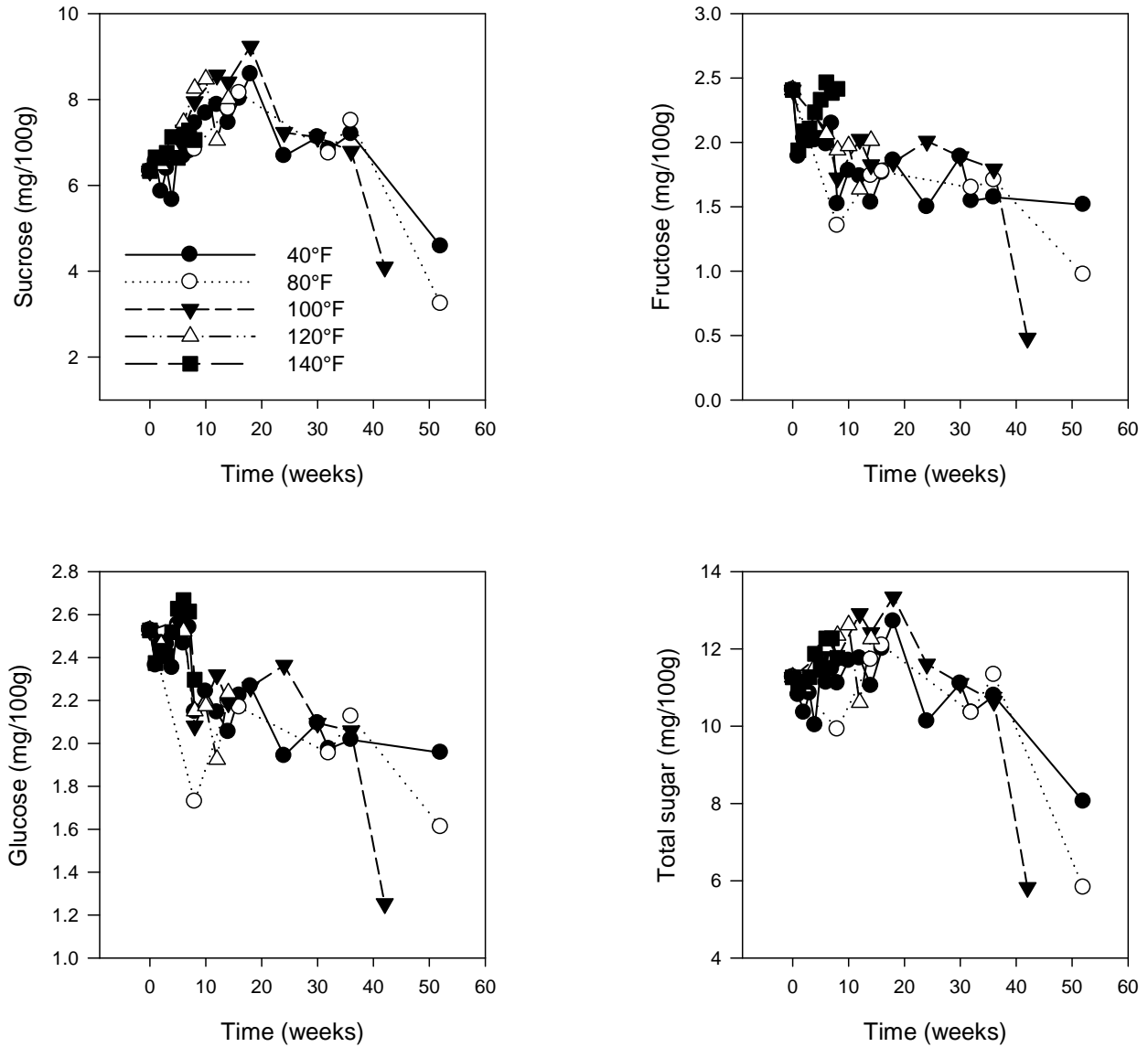

Figure 85. Changes in sugar profiles (sucrose, glucose, fructose, and total sugar) of Wheat Snack Bread during a 52-week storage period at 40, 80, 100, 120, and 140°F

Similarly to what was observed for sucrose and total sugars, the maltodextrin concentration increased during 24 weeks of storage and afterwards decreased (Figure 57). After 24 weeks of storage, samples stored at 100°F had the lowest maltodextrin concentration. Maltodextrin levels of samples stored at 40 and 80°F did not show major changes during 52 weeks of storage (Figure 86).

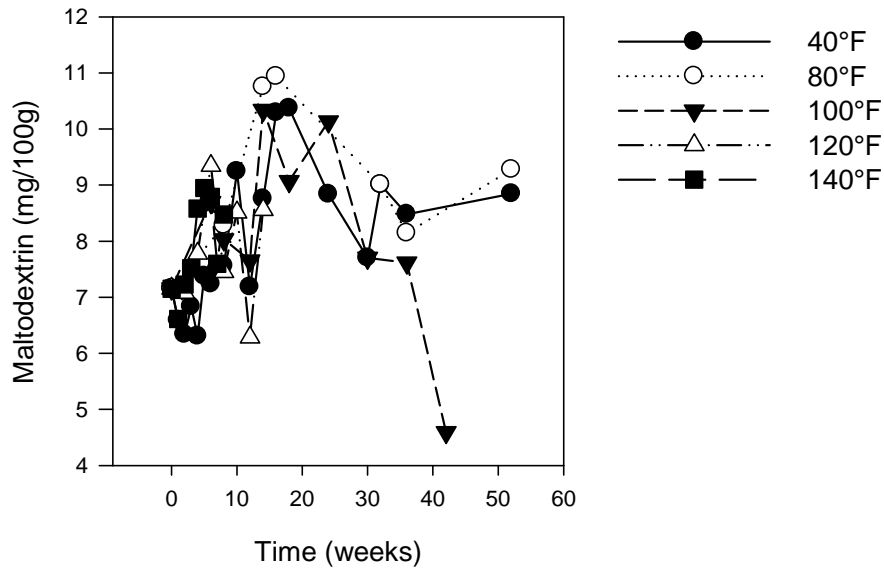

Figure 86. Changes in maltodextrin content of Wheat Snack Bread during a 52-week storage period at 40, 80, 100, 120, and 140°F

Lipid Oxidation:

The level of lipid oxidation was measured using peroxide value (PV) assay to monitor the primary oxidation products formed. Figure 87 represents the level of peroxide value in Wheat Snack Bread during 52 weeks storage at 40, 80, 100, 120, and 140°F. After 52 weeks, the degree of lipid oxidation fluctuated for all temperatures, except for samples stored at 40°F. It was found that the lipid oxidation was not responsible for quality loss of Wheat Snack Bread regardless of storage time and temperature since overall the samples showed a low peroxide value, considering a range of 7-30 meq/kg as the limit of acceptability reported in the literature for different foods (in Materials and Methods).

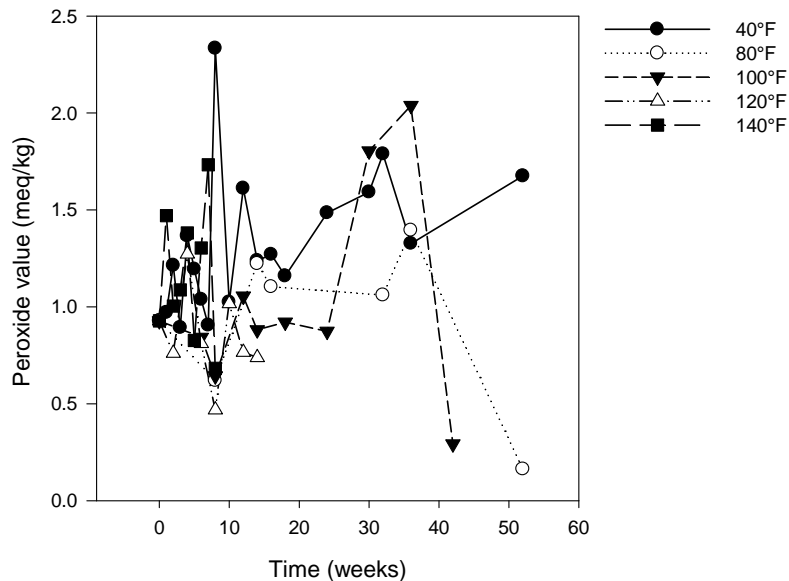

Figure 87. Changes in the peroxide value of Wheat Snack Bread during a 52-week storage period at 40, 80, 100, 120, and 140°F.

2.3.4 Beef Snack, Sweet BBQ

2.3.4.1 Physical Characteristics

Color:

Beef Snack, Sweet BBQ samples exposed to extreme temperature condition (140°F) resulted in sharp decrease in L* value, hue angle, and chroma value at the end of an 8 week storage period (Figure 88). These samples exhibited very dark, almost black appearance (Figure 89). The chroma and hue angle of samples stored at 40, 80, and 100°F decreased significantly after 32 weeks storage, and the L* value of these samples slightly increased, denoting a darker color and enhanced color saturation.

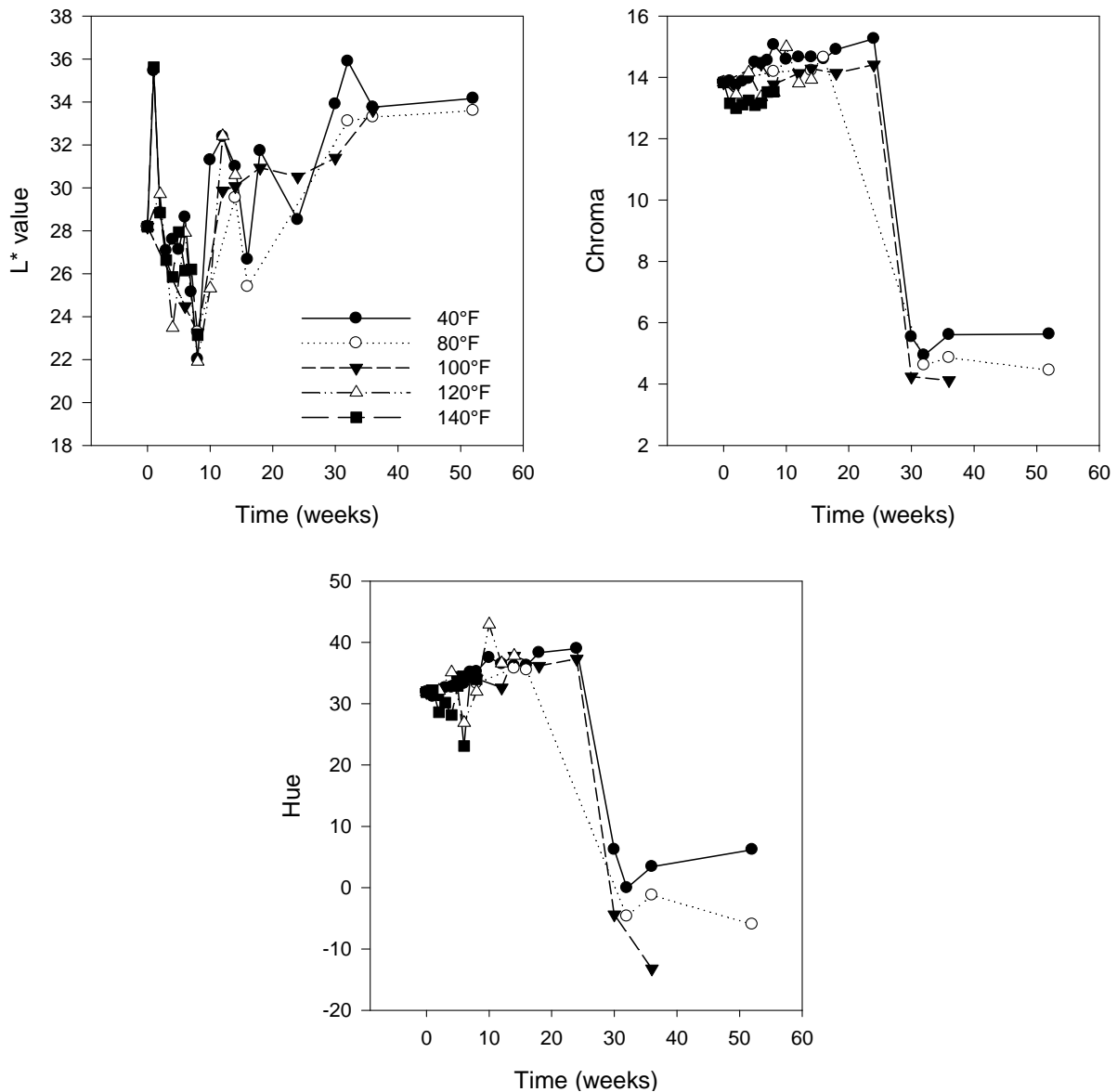

Figure 88. Changes in color attributes (L*, chroma, and hue) of Beef Snack, Sweet BBQ during a 52-week storage period at 40, 80, 100, 120, and 140°F

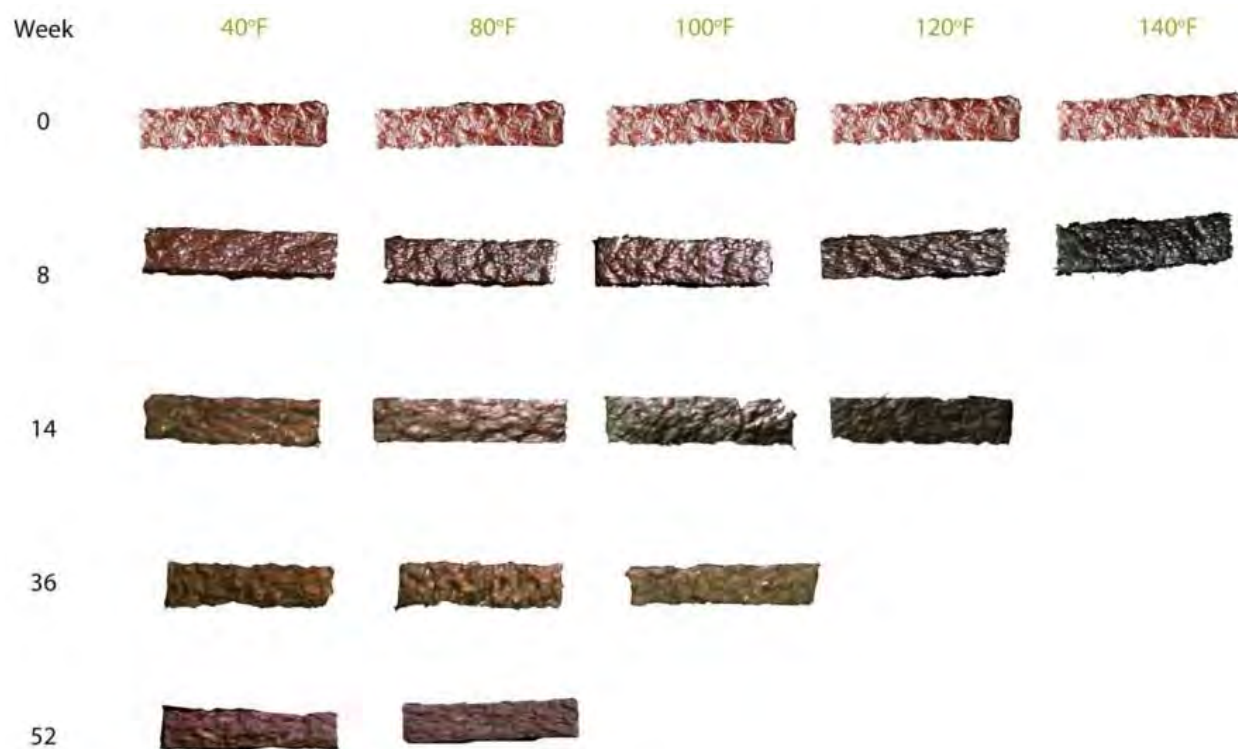

Figure 89. Changes in the appearance of Beef Snack, Sweet BBQ during storage for a 52-week period at 40, 80, 100, 120, and 140°F

Texture:

As the storage temperature increased from 40 to 140°F, the firmness of the Beef Snack, Sweet BBQ started to increase (Figure 90). The sharpest increase in firmness (harder samples) was observed for samples stored at 140°F after an 8-week storage period. The main reason for the increase in firmness and therefore toughening of the samples could have been caused by the loss of moisture content and decrease in water activity. No major textural difference for the Beef Snack, Sweet BBQ was found between samples stored at 40 and 80°F during 52 weeks.

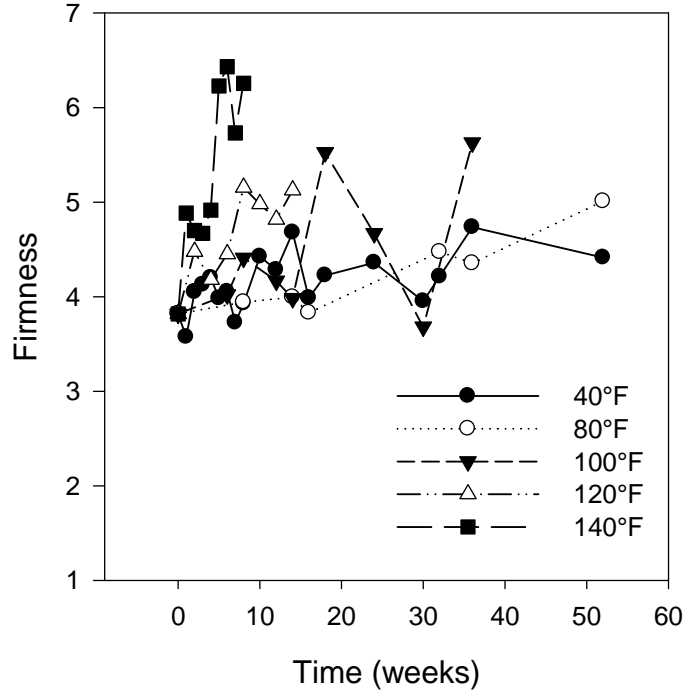

Figure 90. Changes in the texture of Beef Snack, Sweet BBQ during a 52-week storage period at 40, 80, 100, 120, and 140°F

2.3.4.2 Compositional Analysis

Titrateable Acidity, Soluble Solids Content, and pH:

As the storage temperature increased, the pH of the Beef Snack, Sweet BBQ started to decrease, total soluble solid content increased, and titrateable acidity fluctuated (Figure 91). During 52 weeks storage period, the pH of all samples decreased regardless of the storage temperature; however, pH of samples stored at higher temperature decreased rapidly, especially for samples stored at 120 or 140°F. Titrateable acidity showed an increase early on during storage at higher temperatures and an increase followed by a decrease in samples stored at 40, 80, and 100°F during 52 weeks. Samples stored at 140°F showed 64% increase in total soluble solids contents after 8 weeks storage compared to initial measurements.

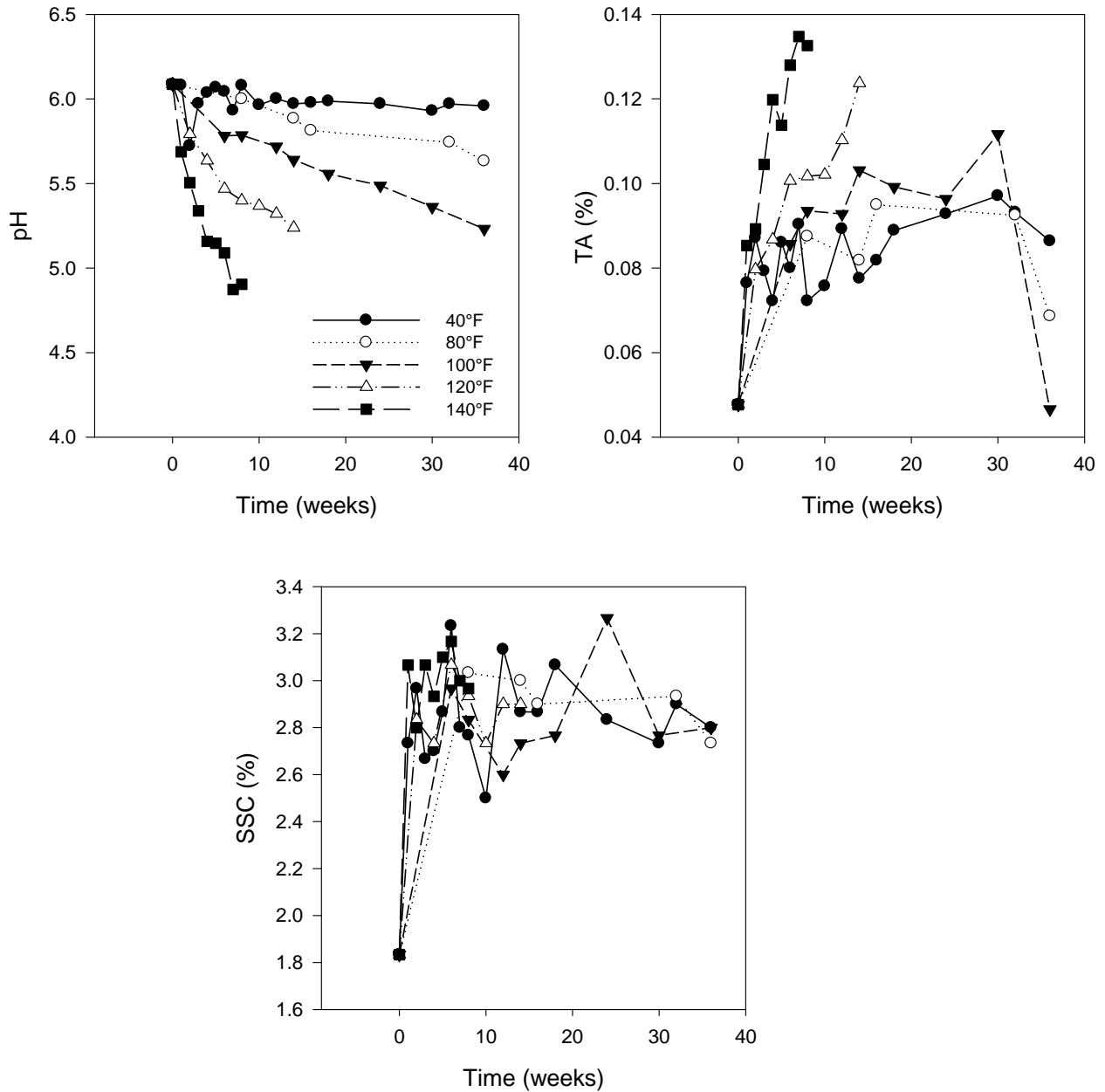

Figure 91. Changes in pH, titratable acidity, and soluble solids content of Beef Snack, Sweet BBQ during a 36-week storage period at 40, 80, 100, 120, and 140°F

Water Activity and Moisture Content:

The results for water activity and moisture content changes for the Beef Snack, Sweet BBQ are shown in Figure 92. Water activity decreased as the temperature increased; however, after an 8 week storage period samples stored at 140°F experienced the lowest water activity compared to other temperatures (Figure 92). Moisture content changed slightly for samples stored at lower temperatures but exposure to higher temperatures resulted in a decreased moisture content.

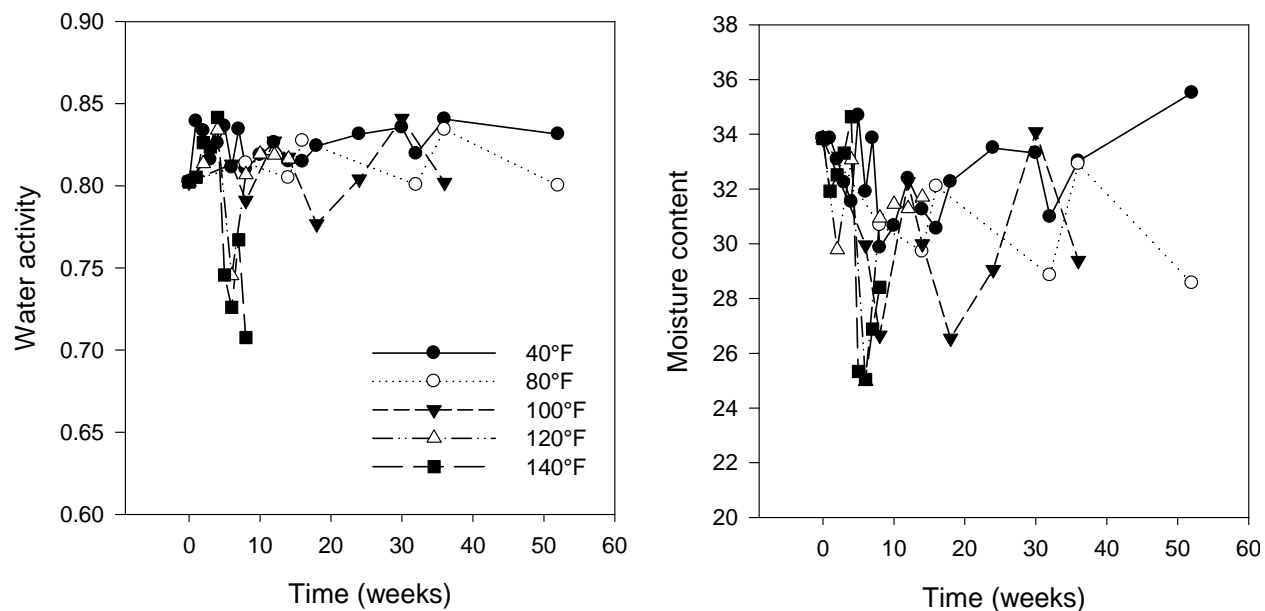

Figure 92. Changes in water activity and moisture content of Beef Snack, Sweet BBQ during storage for a 52-week storage period at 40, 80, 100, 120, and 140°F

Individual and Total Sugar Profiles:

Sucrose was the main sugar measured in Beef Snack, Sweet BBQ (Figure 93). When storage temperature increased, the amount of sucrose decreased sharply, particularly in samples stored at 120 and 140°F (Figure 93). This could have been a result of degradation of sucrose when exposed to high temperature. Samples stored at 40 and 80°F did not show major change in the sucrose concentration. In addition, the amount of fructose showed an increase as the temperature levels increased. The concentration of glucose and total sugar content decreased regardless of the storage temperature.

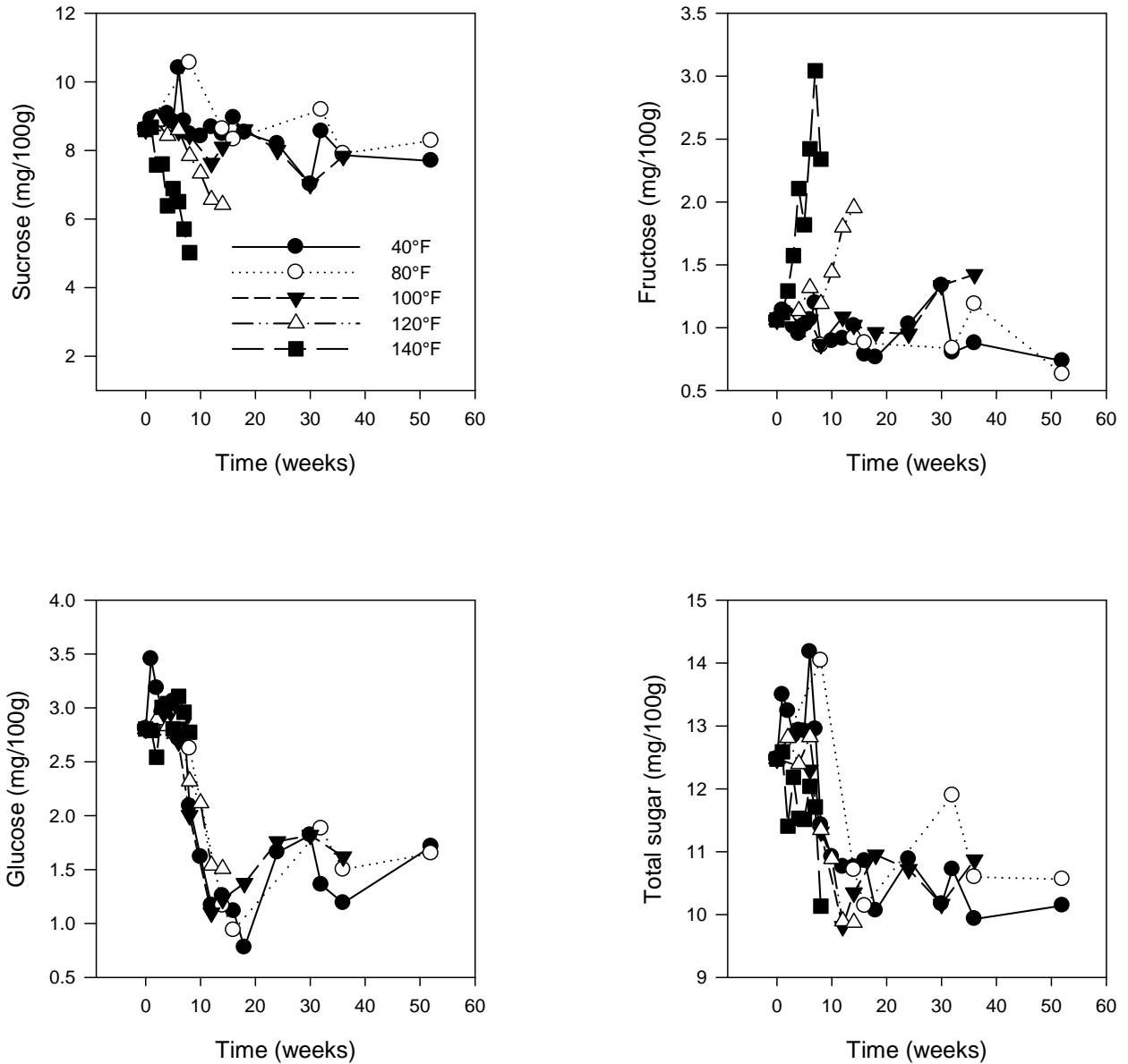

Figure 93. Changes in the sugar profile (sucrose, glucose, fructose, and total sugar) of Beef Snack, Sweet BBQ during a 52-week storage period at 40, 80, 100, 120, and 140°F

Maltodextrin content of Beef Snack, Sweet BBQ sample stored at 120 and 140°F decreased significantly after 8 weeks (Figure 94). The amount of maltodextrin obtained the lowest value in samples stored at 140°F compared to other temperatures. However, after 52 weeks there was no major difference among the samples stored at 40, 80, and 100°F.

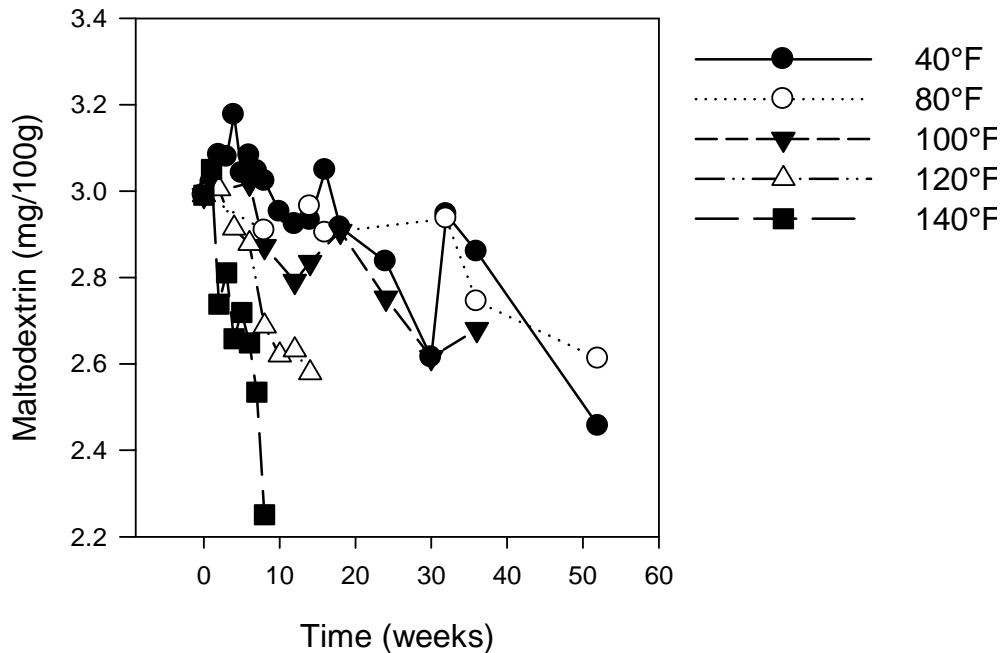

Figure 94. Changes in maltodextrin content of Beef Snack, Sweet BBQ during a 52-week storage period at 40, 80, 100, 120, and 140°F

Lipid Oxidation:

Peroxide value was measured in Beef Snack, Sweet BBQ samples during 52 weeks of storage at 40, 80, 100, 120, and 140°F (Figure 95). Lipid oxidation levels fluctuated regardless of the storage time and temperature. At first, PV value decreased after 8 weeks storage regardless of temperature, but later it showed a sudden increase. Although PV values were higher in this type of FSR item compared to the previous items analyzed, considering a range of 7-30 meq/kg as the limit of acceptability reported in the literature for different foods (in Materials and Methods) the PV obtained for Beef Snack, Sweet BBQ was still below 30 meq/kg. Samples stored at 40 and 80°F did not show major changes in their amount of PV value after 52 weeks storage.

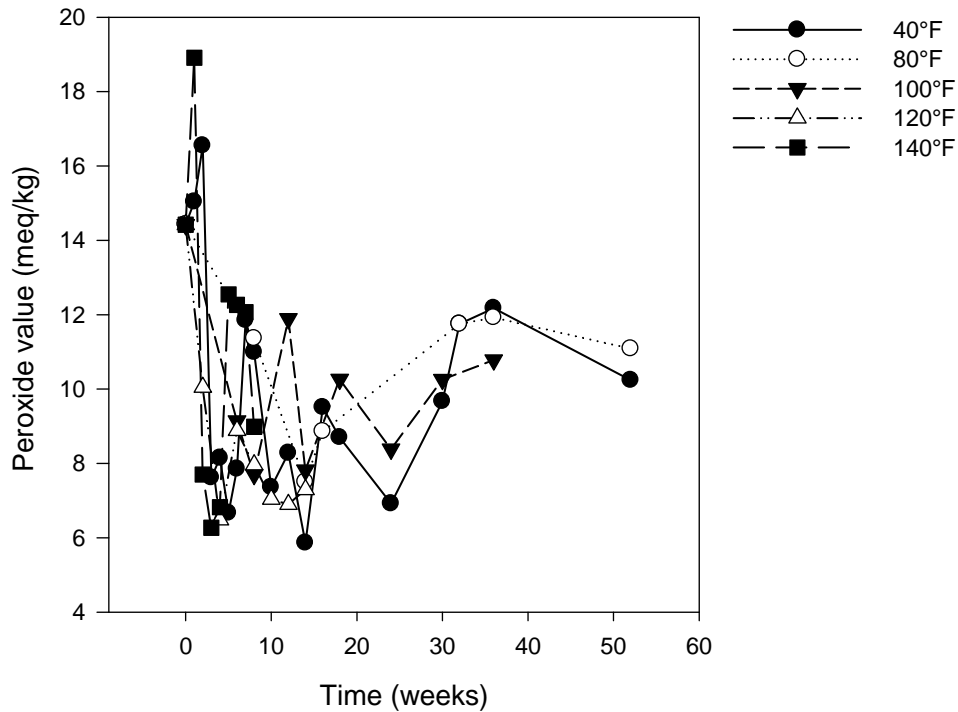

Figure 95. Changes in peroxide value of Beef Snack, Sweet BBQ during a 52-week storage period at 40, 80, 100, 120, and 140°F

2.3.5. Applesauce, CHO Enhanced (Zapplesauce)

2.3.5.1 Physical Characteristics

Color Analysis:

Figure 96 shows the changes in L*value, hue angle, and chroma values of Applesauce samples during 52 weeks at different temperatures. After 52 weeks of storage L* values decreased as temperature increased but changed slightly in samples stored at 80°F and 40°F. Exposure to extreme temperatures (120 and 140°F) considerably decreased the L* value, hue angle, and chroma values of Applesauce when compared to storage at 80 and 40°F. As the temperature increased, the appearance of the samples changed and the color became brownish dark (Figure 97). Brown color development occurred after 8 weeks storage at 100°F and higher temperatures and was amplified by the exposure time and temperature. The brownish appearance of Applesauce could have resulted from non-enzymatic browning caused by exposure to high temperatures.

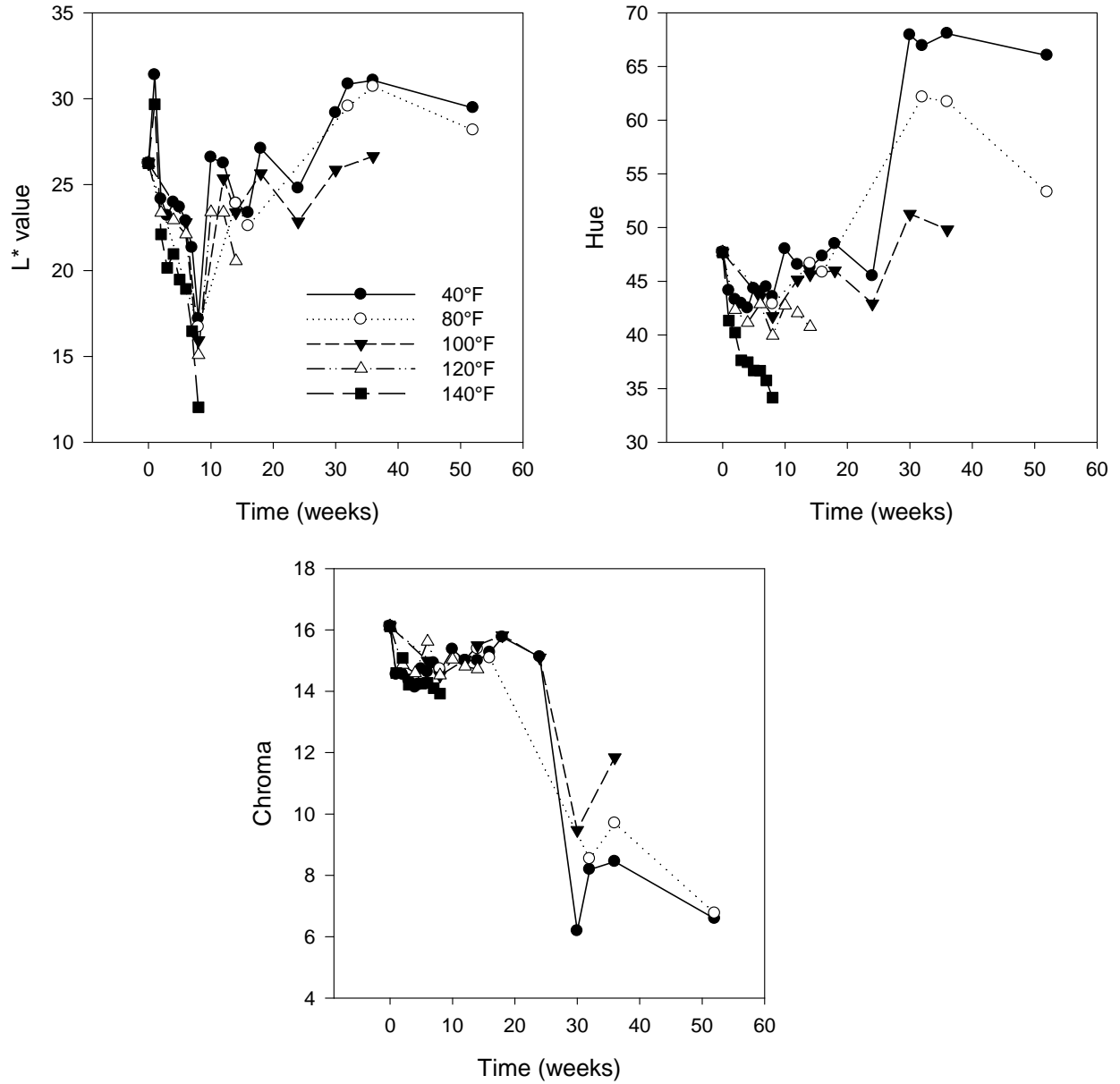

Figure 96. Changes in color attributes (L*, chroma, and hue) of Applesauce during a 52-week storage period at 40, 80, 100, 120, and 140°F

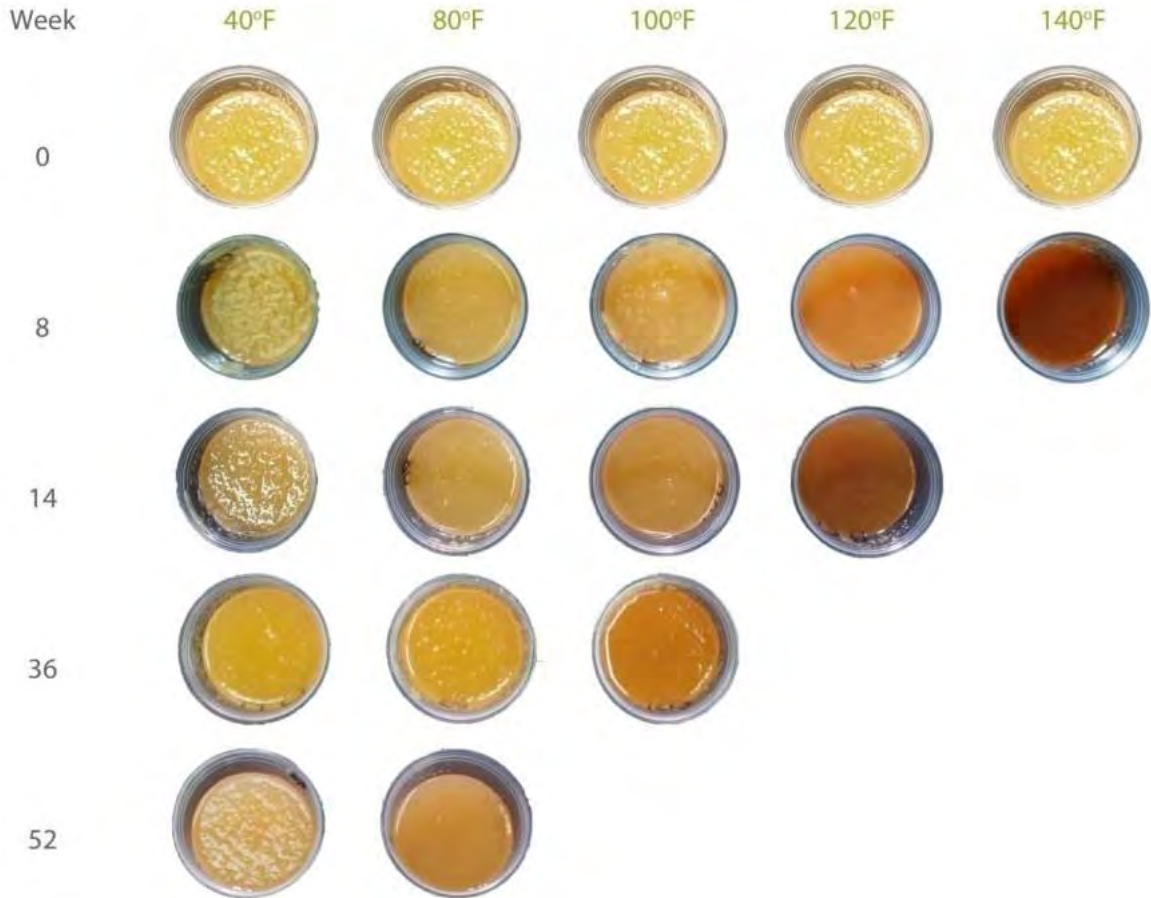

Figure 97. Changes in the appearance of Applesauce during a 52-week storage period at 40, 80, 100, 120, and 140°F

Texture:

Changes in the texture of Applesauce stored in different temperatures during 52 weeks are shown in Figure 98. The major effect of temperature was seen on the texture of Applesauce samples stored at 120 and 140°F. Exposure to extreme temperatures caused a decrease in the firmness of the samples from 0.07 kgf to 0.05 kgf at the end of 8 weeks storage period. This decrease in firmness was translated by a thinner or watery texture (loss of consistency of the puree) particularly in samples exposed to temperatures higher than 80°F.

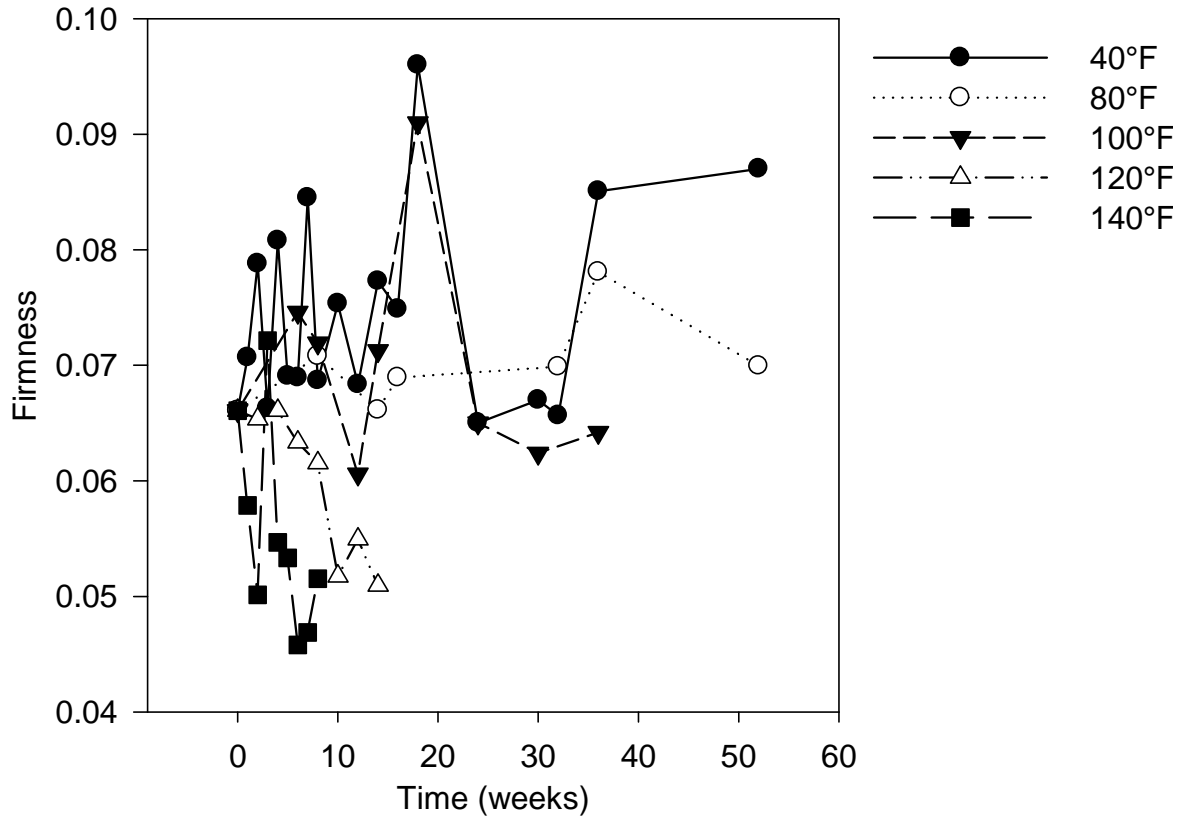

Figure 98. Changes in the texture of Applesauce during a 52-week storage period at 40, 80, 100, 120, and 140°F

2.3.5.2 Compositional Analysis

Titrateable Acidity, Soluble Solids Content, and pH:

The titrateable acidity, soluble solids content and pH of Applesauce stored for 36 weeks at different temperatures are shown in Figure 99. The pH showed a decreasing trend; while titrateable acidity had an increasing trend during storage regardless of the storage temperature. There was no major change in soluble solid contents regardless of the storage temperature.

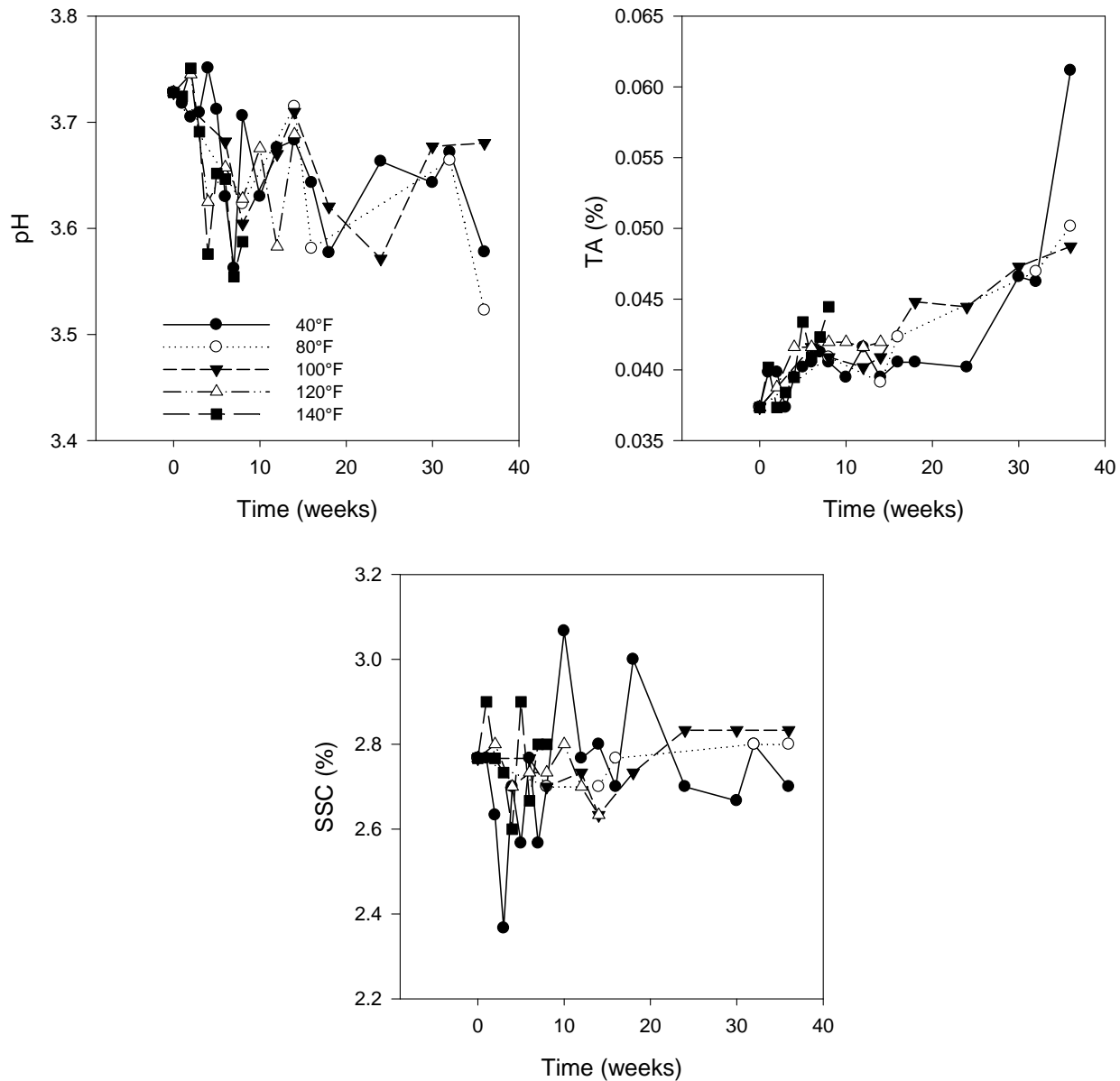

Figure 99. Changes in pH, titratable acidity, and soluble solid contents of Applesauce during a 36-week storage period at 40, 80, 100, 120, and 140°F

Water Activity and Moisture Content:

The results for changes in water activity and moisture content for Applesauce are shown in Figure 100. Water activity increased during storage regardless of temperature; however, samples stored at 140°F showed the highest water activity compared to samples stored at other temperatures (Figure 100).

Moisture content of Applesauce changed slightly for samples stored at 100°F or lower temperatures but exposure to higher temperatures resulted in an increased moisture content. The possible reason for that could have been that bound water molecules became free and contributed to the increase in the total moisture content.

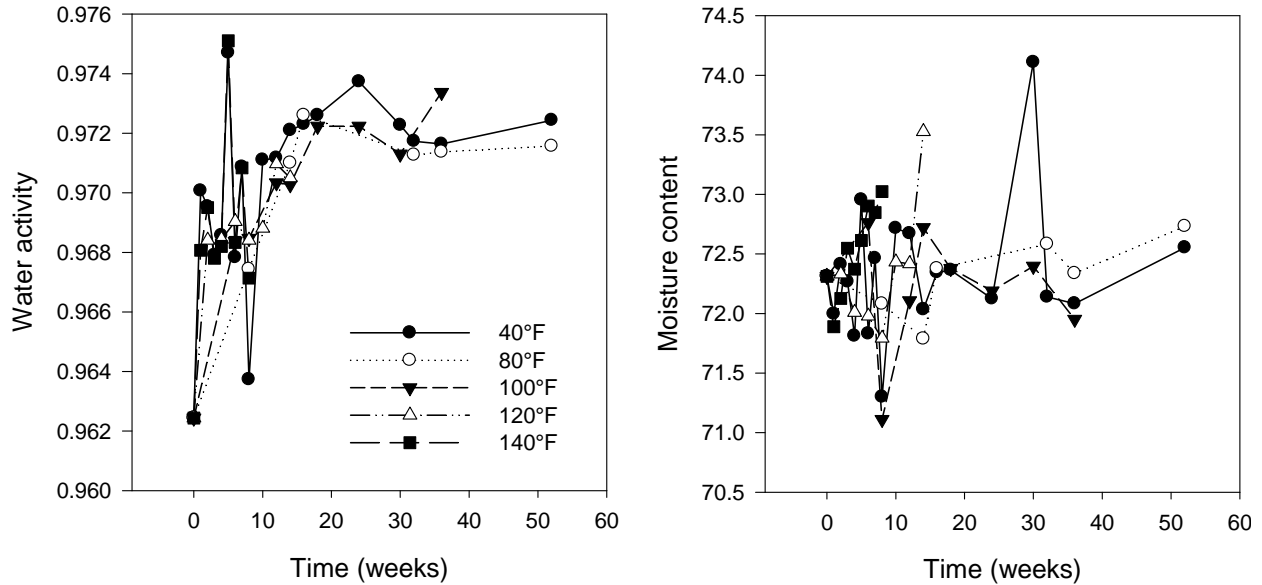

Figure 100. Changes in water activity and moisture content of Applesauce during a 52-week storage period at 40, 80, 100, 120, and 140°F

Ascorbic Acid Content:

The ascorbic acid is a key compound as it prevents oxidation and browning reactions in food. In this study, there was only a slight change in the amount of the ascorbic acid of samples stored at refrigerated conditions (40°F). However, as the temperature increased the degradation of total ascorbic acid during storage was striking (Figure 101). For example, ascorbic acid content of Applesauce decreased by 78% in samples stored at 120°F and by 93% in samples stored at 140°F.

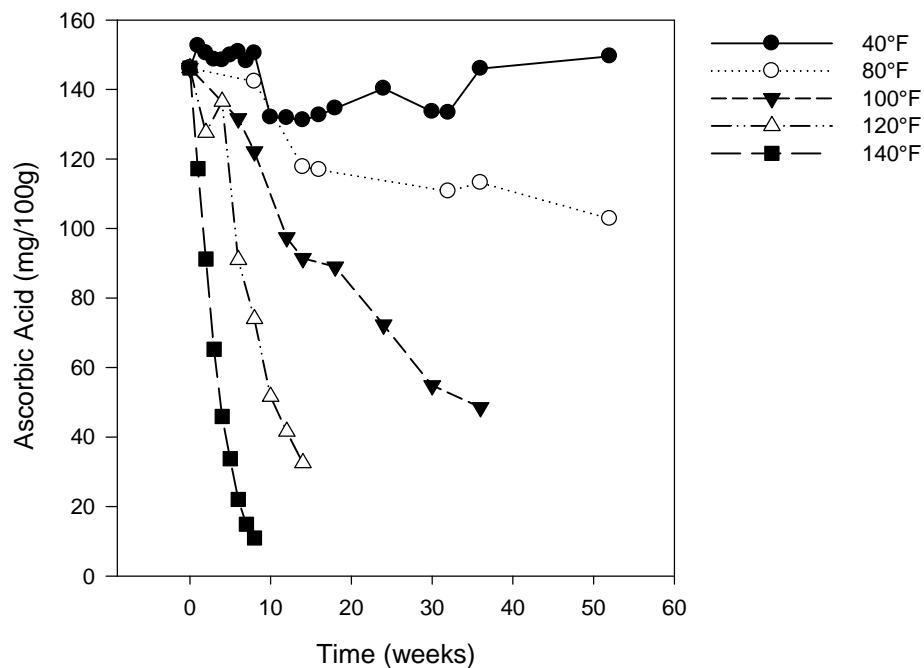

Figure 101. Ascorbic acid changes in Applesauce during a 52-week storage period at 40, 80, 100, 120, and 140°F

Individual and Total Sugar Profiles:

As sucrose concentration decreased, the glucose and fructose concentration increased for samples stored at 100°F or higher temperatures. Increased temperatures resulted in hydrolysis of sucrose into fructose and glucose (Figure 102). However, the total sugar concentration of Applesauce stored at 140°F had a higher value than that of samples stored at lower temperatures. This could be explained by the concentration effect on total sugar content due to the water loss during storage at high temperature. After 52 weeks of storage, the total sugar levels decreased significantly for samples stored at 40 and 80°F.

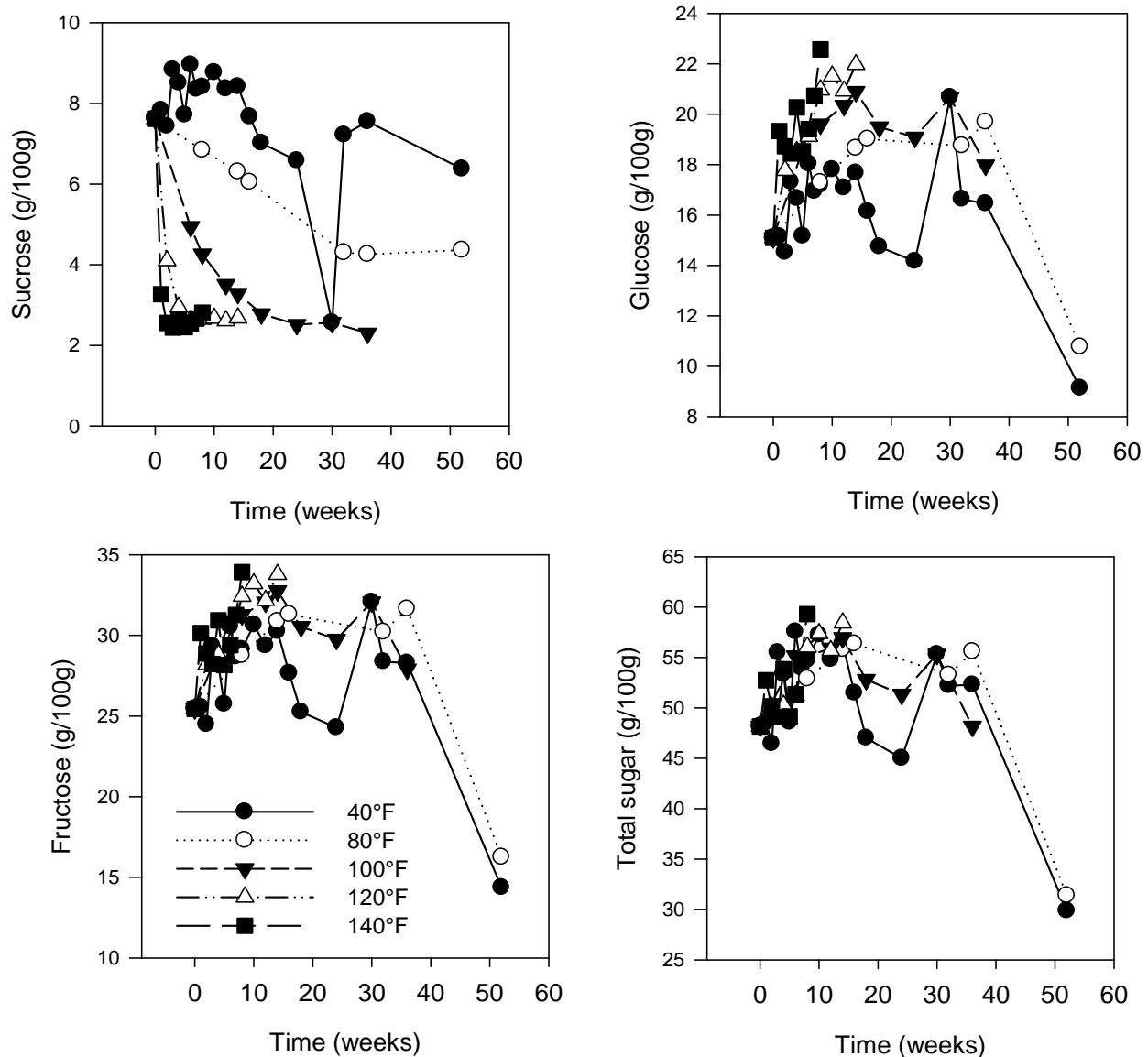

Figure 102. Changes in sugar profiles (sucrose, glucose, fructose, and total sugar) of Applesauce during a 52-week storage period at 40, 80, 100, 120, and 140°F

Maltodextrin levels increased for all samples up to week 14 of storage, and then began to fluctuate and slowly decreased during weeks 36-52 (Figure 103). Maltodextrin content of samples stored at 40 and 80°F showed a sharp decrease from week 36 to week 52.

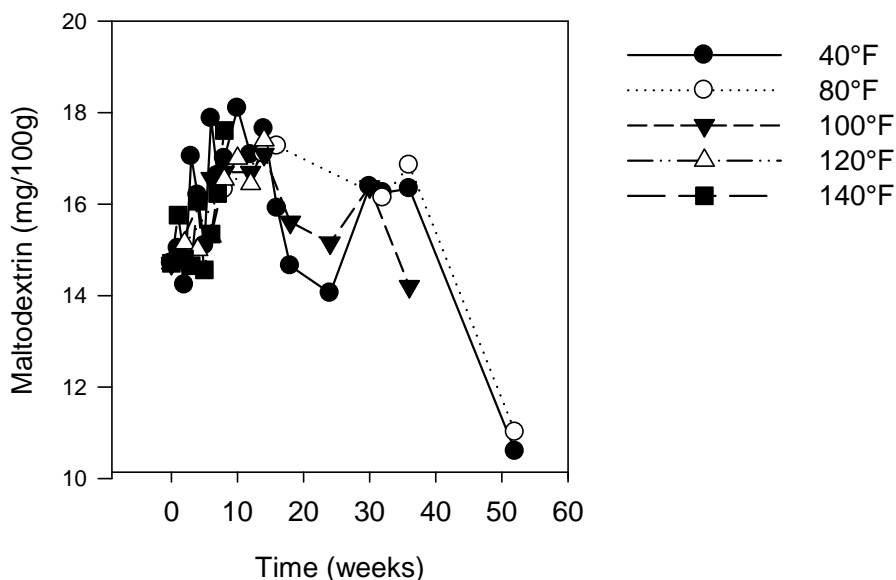

Figure 103. Changes in maltodextrin content of Applesauce during a 52-week storage period at 40, 80, 100, 120, and 140°F

2.3.6 Italian Pocket Sandwich:

2.3.6.1 Physical Characteristics

Color:

A sharp decrease in L* value, chroma, and hue angle occurred after 8 weeks when Italian Pocket Sandwich samples were exposed to high temperatures (120 and 140°F) (Figure 104). This remarkable change was also seen in the appearance of Italian Pocket Sandwich (Figure 105). That is, as the temperature increased, the color of the sample became a dark brown. This browning color developed after 8 weeks in storage at higher temperatures (120 and 140°F) and accelerated with exposure time. The reason for the development of brown was most likely associated with a non-enzymatic reaction that was accelerated by exposure to extreme temperatures.

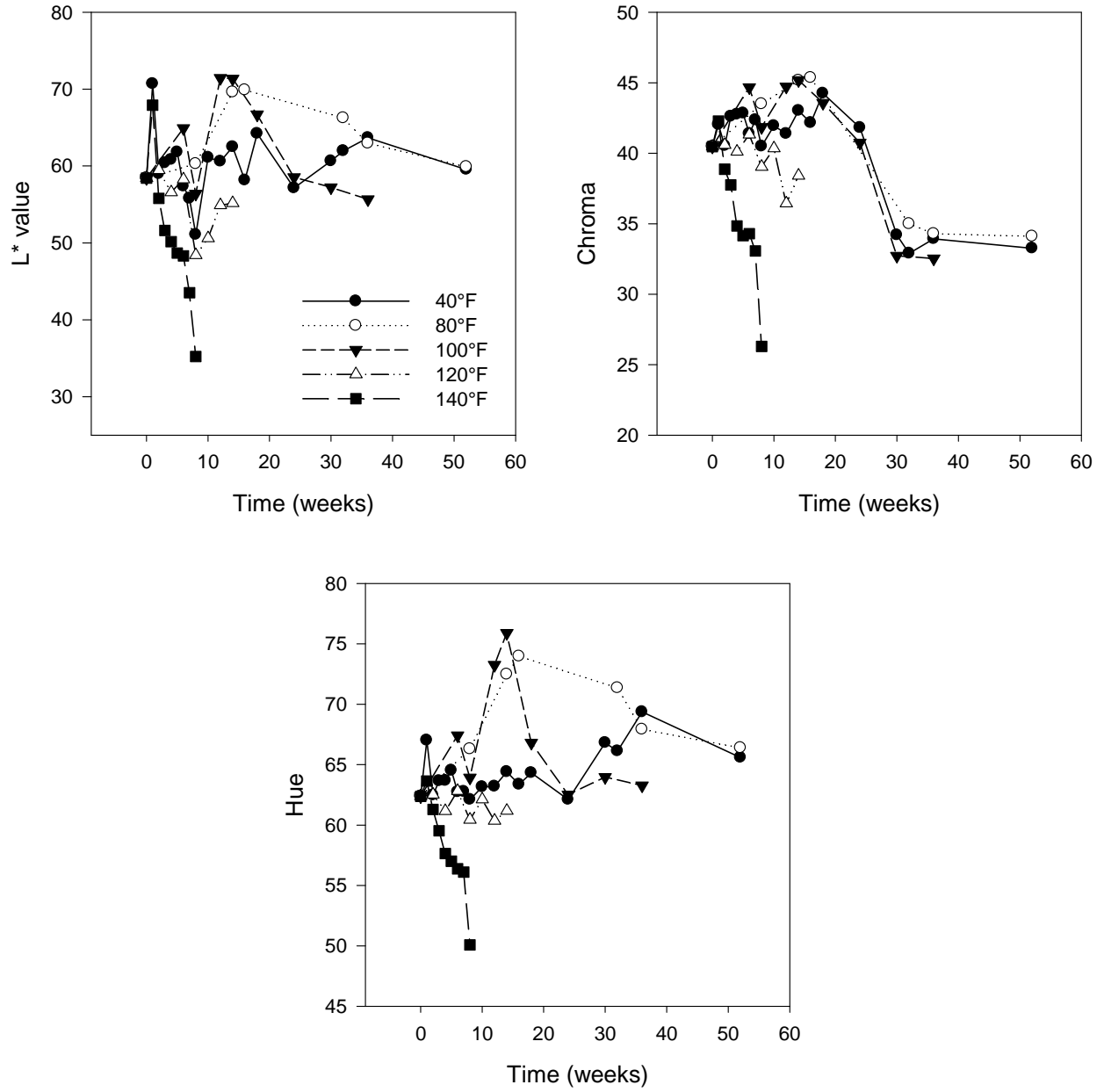

Figure 104. Changes in color attributes (L*, chroma, and hue) of Italian Pocket Sandwich during a 52-week storage period at 40, 80, 100, 120, and 140°F

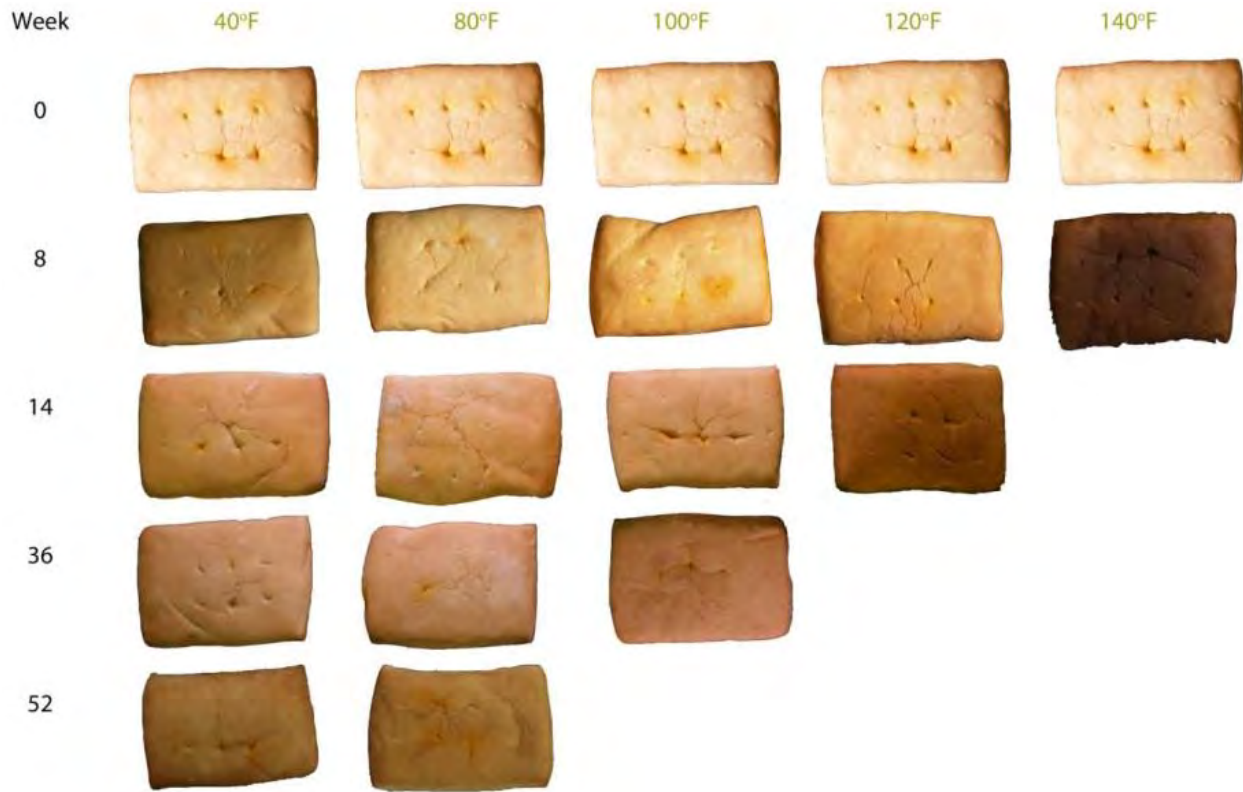

Figure 105. Changes in the appearance of Italian Pocket Sandwich during a 52-week storage period at 40, 80, 100, 120, and 140°F.

Texture:

Italian Pocket Sandwich samples stored at refrigerated condition (40°F) had higher firmness values after 18 weeks than samples stored at other temperatures (Figure 106). That could have been the result of dehydration of the sandwiches or an increase in firmness produced by cooler temperatures. However, as temperature increased the firmness value decreased, due to softening of the samples when exposed to elevated temperatures.

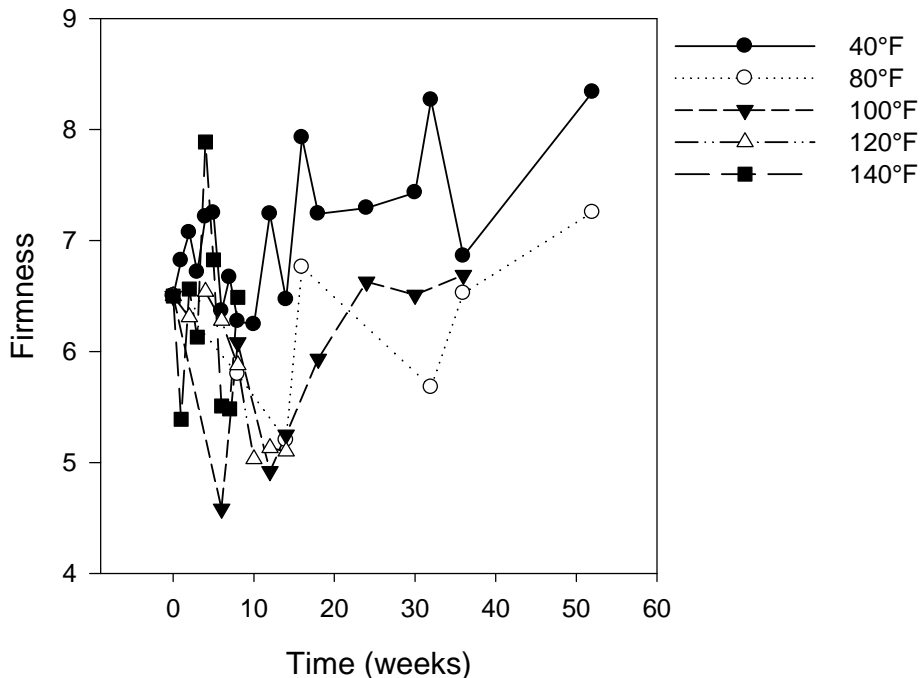

Figure 106. Changes in the firmness of Italian Pocket Sandwich during a 52-week storage period at 40, 80, 100, 120, and 140°F

2.3.6.2 Compositional Analysis

Titratable Acidity, Soluble Solids Content, and pH:

No considerable pH changes were noted in the Italian Pocket Sandwich stored at 40 and 80°F. At 140°F, however, the pH decreased, whereas titratable acidity increased in the same samples stored for 8 weeks, a time that corresponded with the development of brown color. At storage temperatures of 120 and 140°F these biochemical changes were much more marked, particularly at 140°F. Total soluble solid contents increased slightly for all temperatures after 36 weeks of storage (Figure 107).

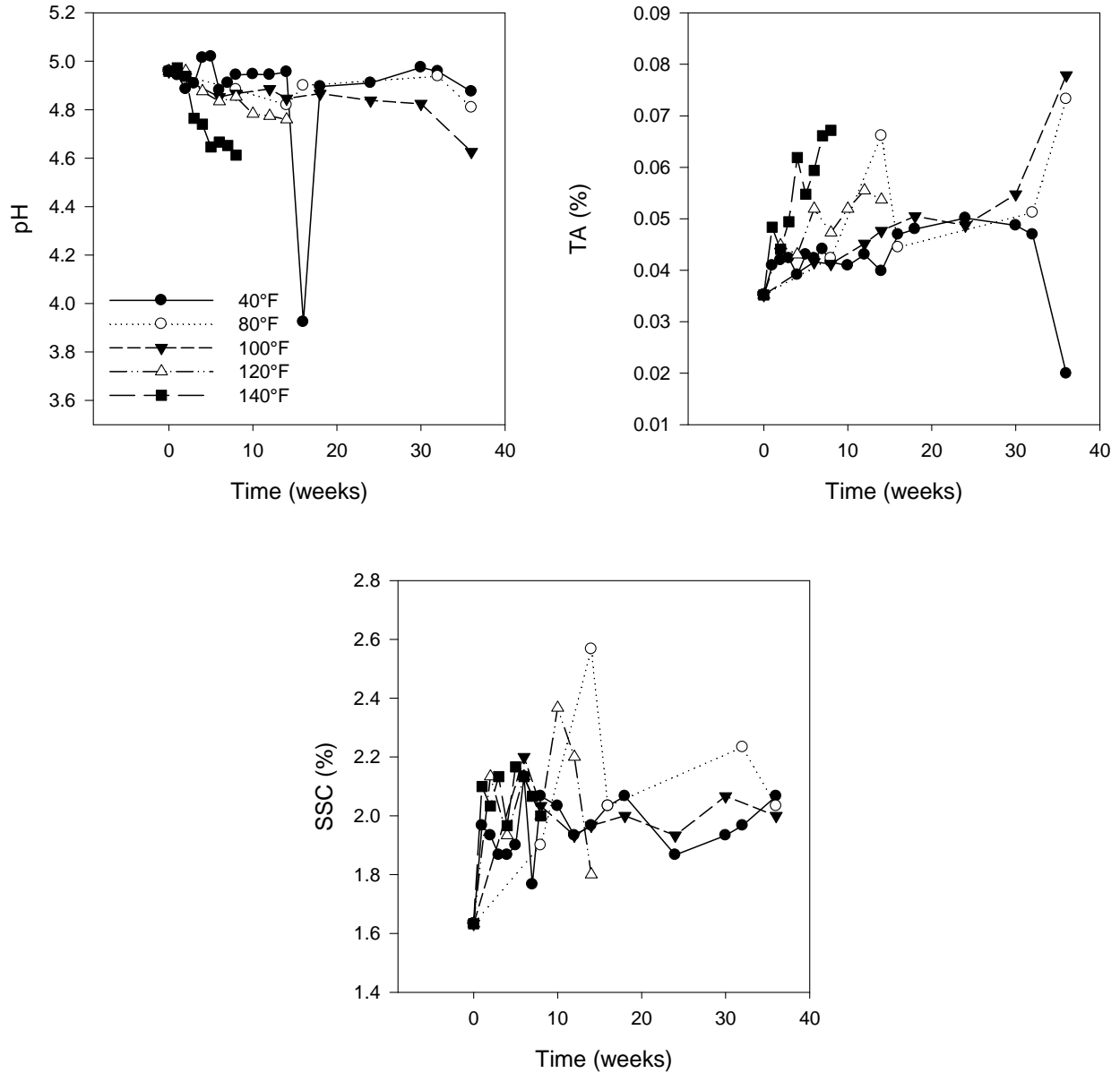

Figure 107. Changes in pH, titratable acidity, and soluble solid contents of Italian Pocket Sandwich during a 36-week storage period at 40, 80, 100, 120, and 140°F

Water Activity and Moisture Content:

Figure 108 represents changes in water activity and moisture content for Italian Pocket Sandwich stored at different temperatures during 52 weeks of storage. Water activity increased during storage regardless of temperature; however, moisture content did not show a certain trend as it fluctuated regardless the storage temperature.

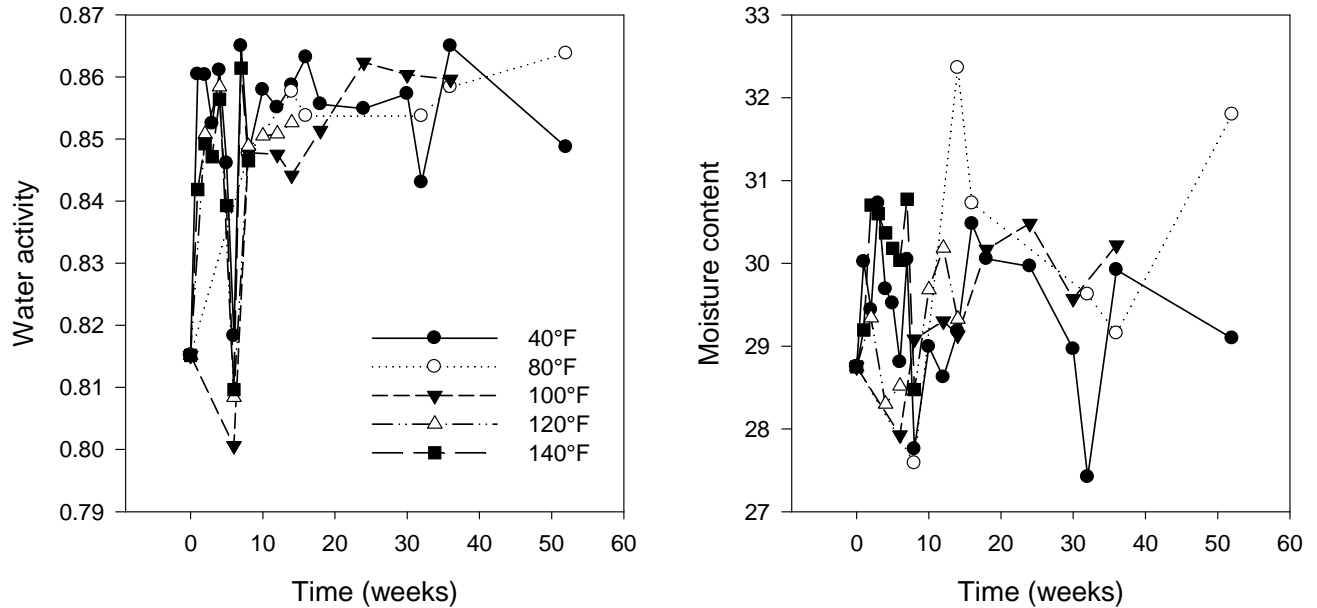

Figure 108. Changes in moisture content and water activity of Italian Pocket Sandwich during a 52-week storage period at 40, 80, 100, 120, and 140°F

Ascorbic Acid Content:

Ascorbic acid content in Italian Pocket Sandwich increased after 8 weeks storage regardless of temperature, but it showed a sudden decrease during the following weeks (Figure 109). The initial increase in the ascorbic acid content of the samples, regardless of the temperature, might have been a consequence of the uneven distribution of ascorbic acid in the samples or might have resulted from the difficulty in the extraction process due to the complexity of the food matrix.

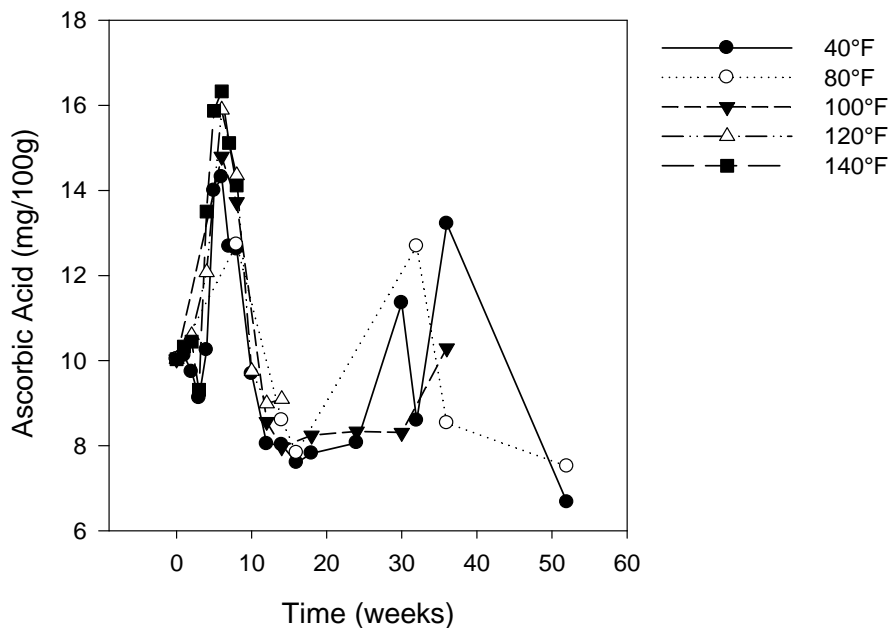

Figure 109. Changes in ascorbic acid content of Italian Pocket Sandwich during a 52-week storage period at 40, 80, 100, 120, and 140°F

Individual and Total Sugar Profiles:

The highest temperatures (120 and 140°F) brought about a sudden decrease in the concentration of sucrose, glucose and total sugar content, particularly in samples stored at 140°F (Figure 110). This could have been the result of degradation of sugars when exposed to high temperature. The lower storage temperatures showed a minimum change in sugar content after 36 weeks storage period, then began to show a decrease in sugar content up to 52 weeks of storage.

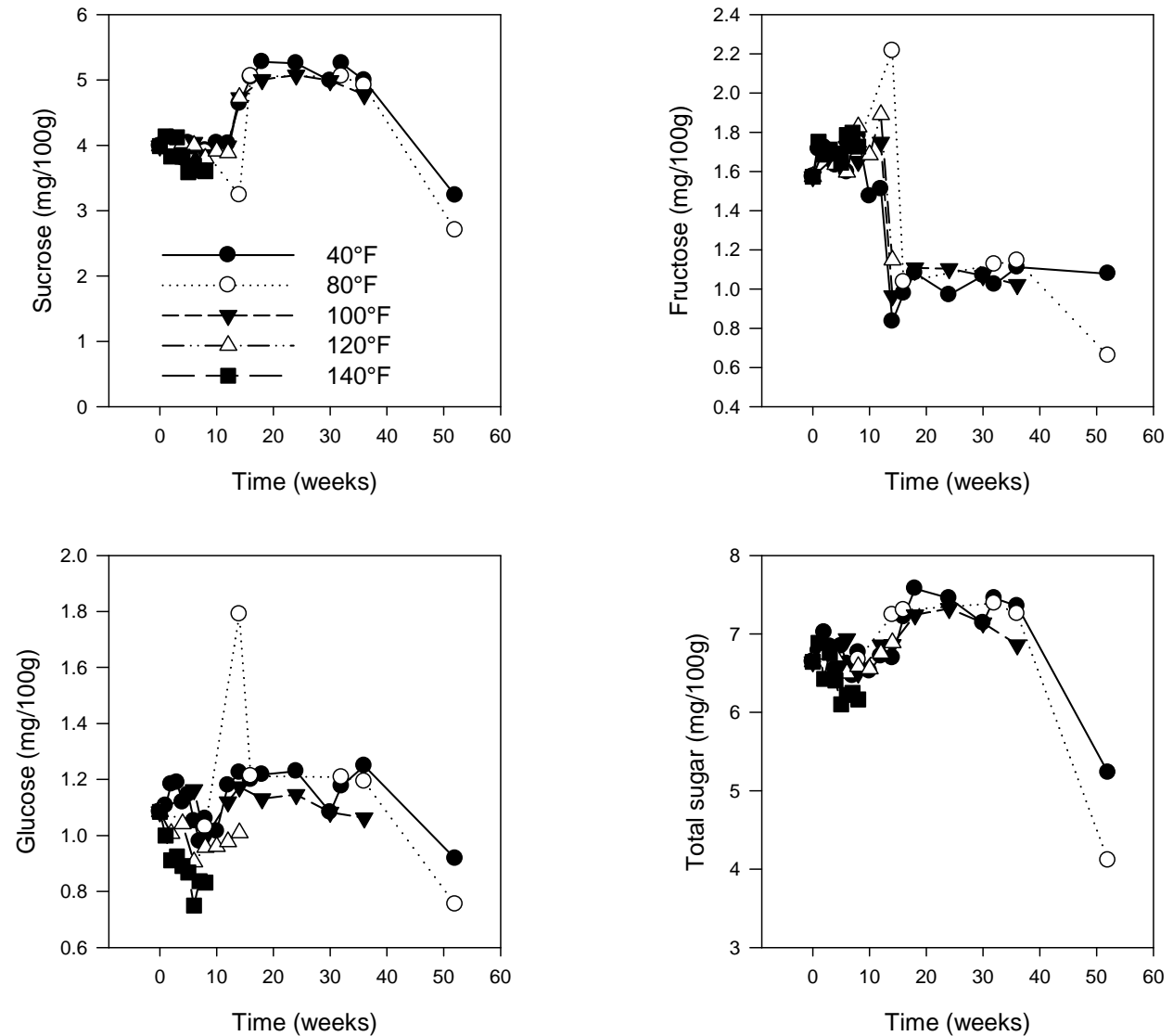

Figure 110. Changes in the sugar profile (sucrose, glucose, fructose, and total sugar) of Italian Pocket Sandwich during a 52-week storage period at 40, 80, 100, 120, and 140°F

Similar to what was observed for the sugar content of Italian Pocket Sandwich, maltodextrin concentration showed a parallel trend (Figure 111). That is, exposure to high temperatures resulted in a decrease in the amount of maltodextrin; however, no major changes occurred in samples stored at lower temperatures (40 and 80°F) after 36 weeks of storage period.

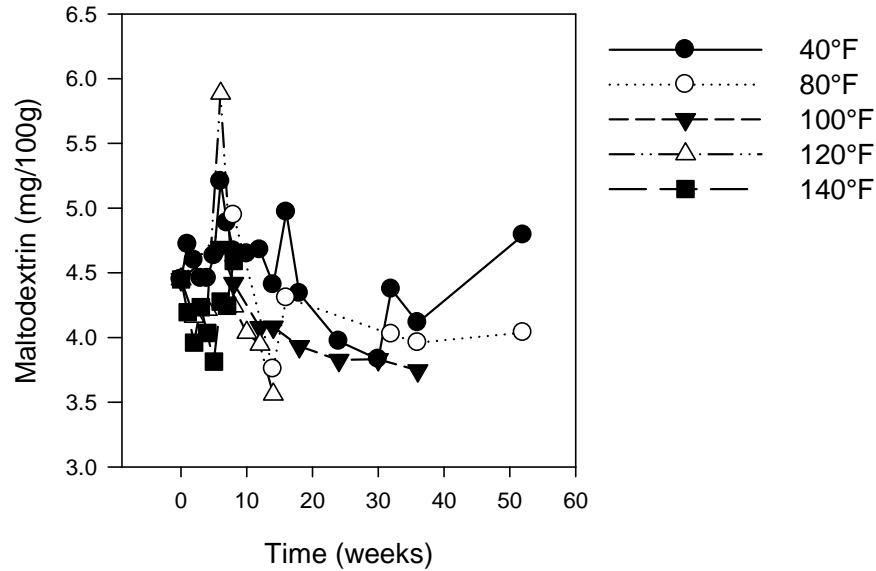

Figure 111. Changes in maltodextrin content of Italian Pocket Sandwich during a 52-week storage period at 40, 80, 100, 120, and 140°F

Lipid Oxidation:

The degree of lipid oxidation was measured using the peroxide value (PV) assay to monitor the primary oxidation products formed. There were two types of sampling methods applied to this product. Entire Italian Pocket Sandwiches and only the meat part of the sandwich were used to measure the level of peroxide value during 52 weeks storage at 40, 80, 100, 120, and 140°F (Figure 112). The results showed that the level of lipid oxidation was low for all temperatures after 52 weeks storage. The lipid oxidation was not found to be a critical point regardless of storage temperature and time for Italian Pocket Sandwich, considering a range of 7-30 meq/kg as the limit of acceptability reported in the literature for different foods (in Materials and Methods).

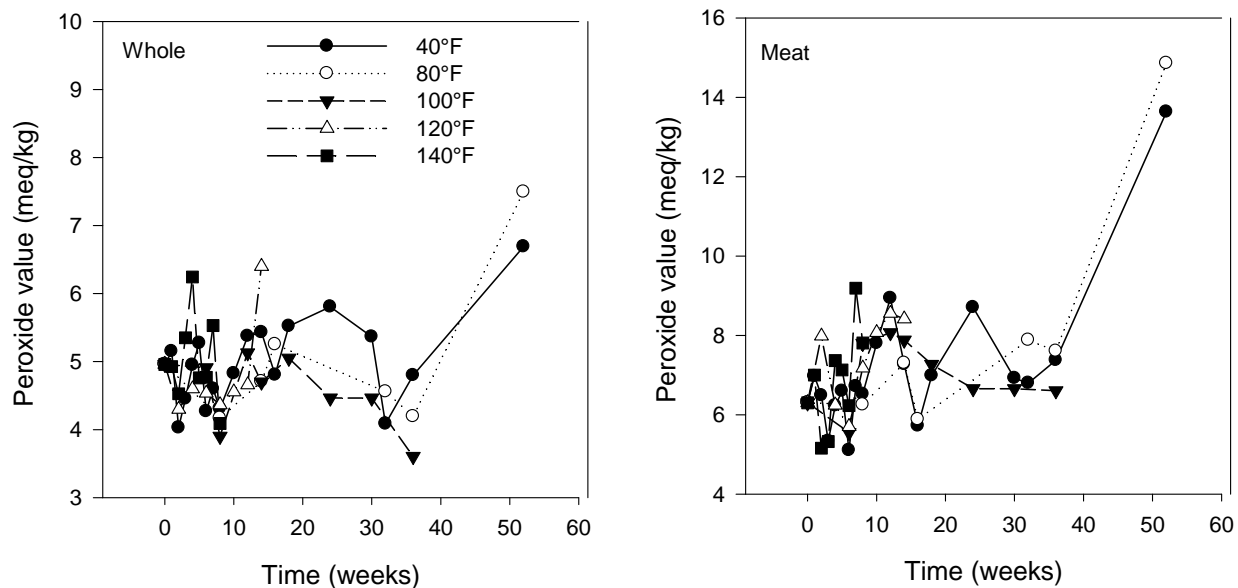

Figure 112. Changes in peroxide value in the whole Italian Pocket Sandwich and meat only during a 52-week storage period at 40, 80, 100, 120, and 140°F

2.3.7 Tortillas

2.3.7.1 Physical Characteristics

Color:

L* value of Tortillas decreased as temperature increased and slightly changed for control and low temperature treatment after 52 weeks storage (Figure 113). Extreme temperature conditions (120 and 140°F) considerably decreased the L* and hue value when compared to modest temperature (80°F) and refrigerated conditions (40°F) during the storage. However, chroma value increased for these temperature conditions (120 and 140°F). As the temperature increased, the color of Tortillas samples became darker brown during storage (Figure 114). Brown color development on Tortillas occurred after 8 weeks storage at 140°F. The brownish color appearance could have been caused by non-enzymatic browning due to the effect of exposure to high temperature.

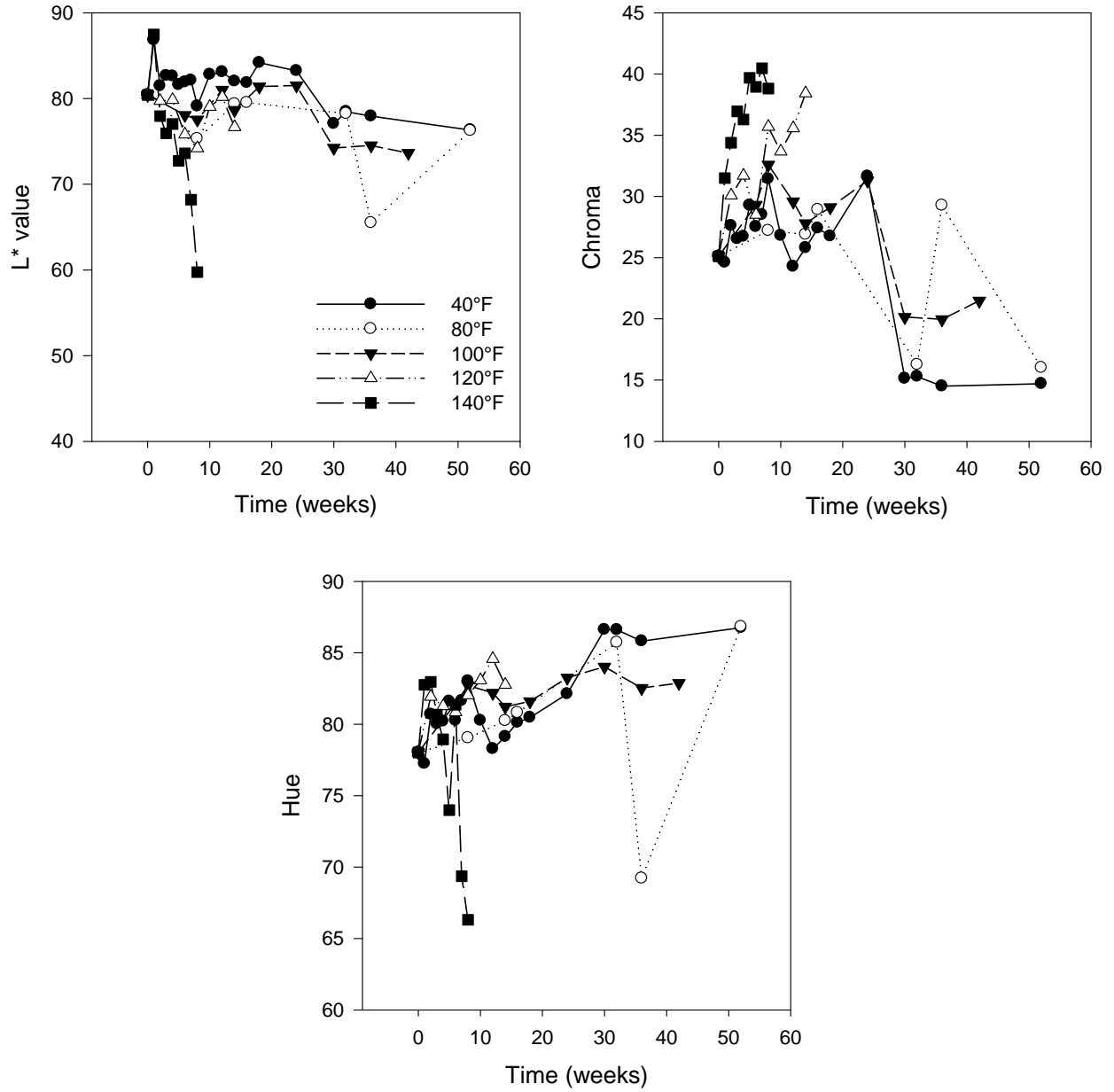

Figure 113. Changes in color attributes (L*, chroma, and hue) of Tortillas during a 52-week storage period at 40, 80, 100, 120, and 140°F



Figure 114. Changes in the appearance of Tortillas during a 52-week storage period at 40, 80, 100, 120, and 140°F

Texture:

After 8 weeks, Tortilla samples stored at refrigerated condition (40°F) showed higher firmness values than those stored at higher (Figure 115). Exposure to extreme temperature conditions (120 and 140°F) contributed to a considerable decrease in the firmness of the samples (Figure 115).

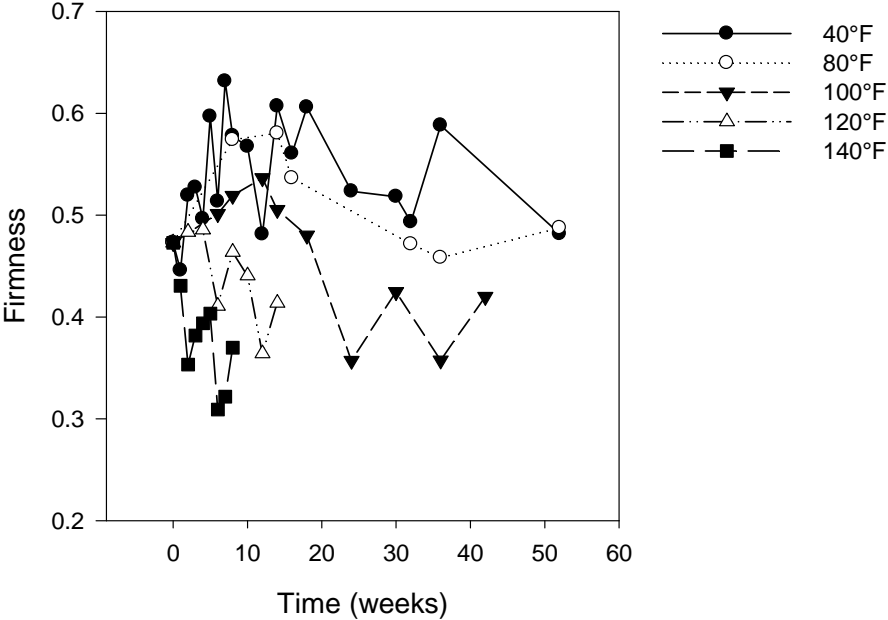

Figure 115. Changes in the texture of Tortillas during a 52-week storage period at 40, 80, 100, 120, and 140°F

2.3.7.2 Compositional Analysis

Titratable Acidity, Soluble Solids Content, and pH:

The total soluble solids content, titratable acidity, and pH of Tortillas stored at different temperatures for 36 weeks are shown in Figure 116. There was no major change found in soluble solids content and pH regardless of the storage time and temperature. However, titratable acidity showed an increasing trend, up until week 36 when it began to decrease.

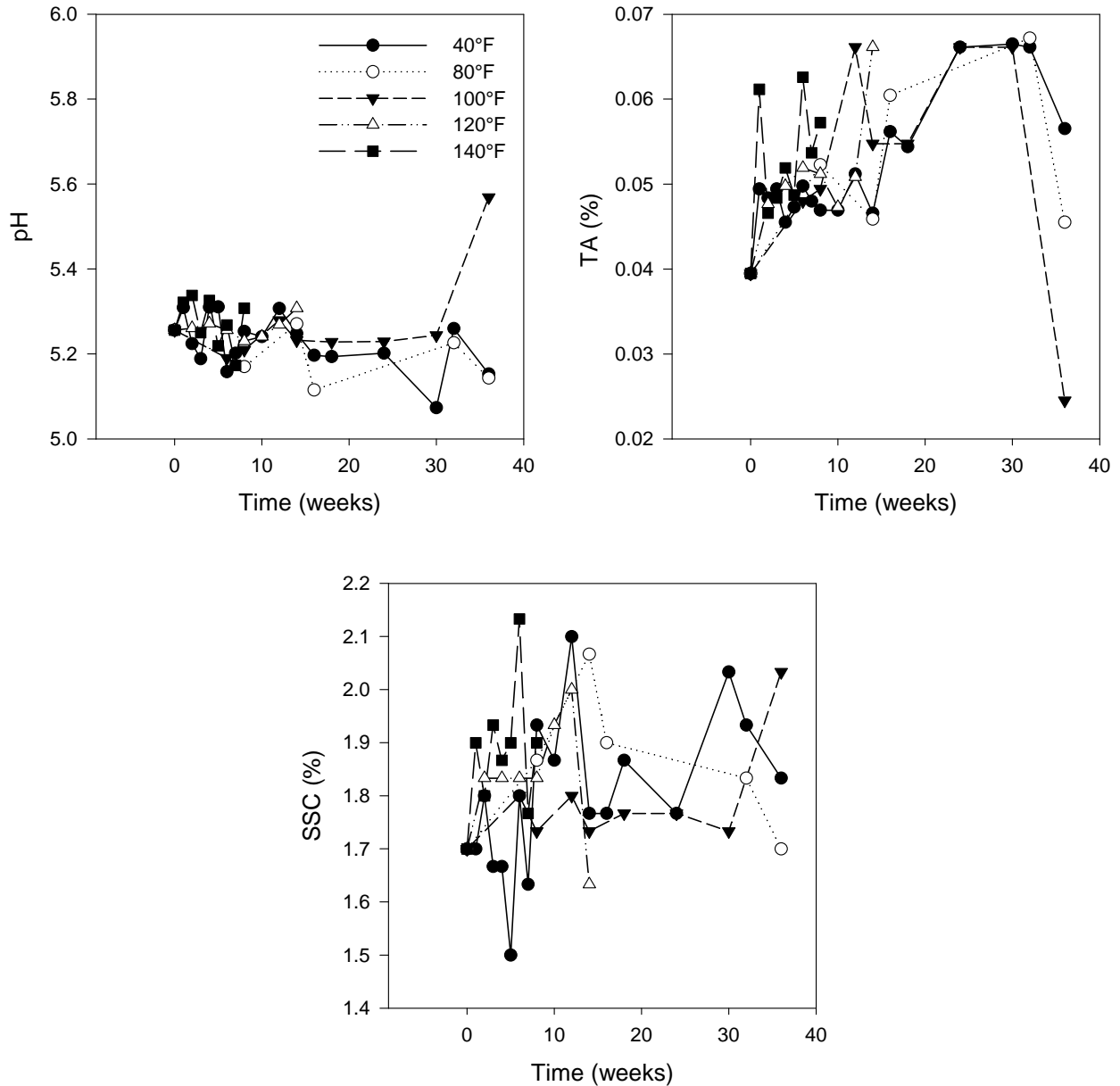

Figure 116. Changes in titratable acidity, soluble solids content, and pH of Tortillas stored during a 36-week storage period at 40, 80, 100, 120, and 140°F

Water Activity and Moisture Content:

Changes in water activity and moisture content for Tortillas stored at different temperatures are shown in Figure 117. The degree of water activity and moisture content fluctuated regardless of storage time or temperature. Water activity showed a general increasing trend; however, moisture content had a decreasing trend during 52 weeks of storage.

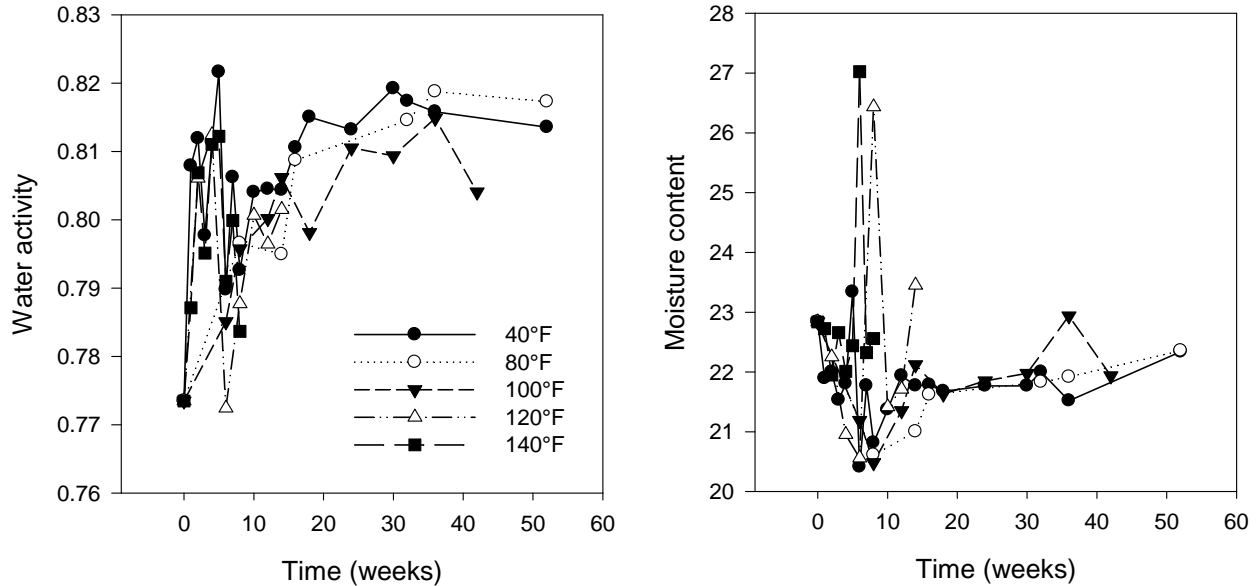

Figure 117. Changes in water activity and moisture content of Tortillas during a 52-week storage period at 40, 80, 100, 120, and 140°F

Individual and Total Sugar Profiles:

The results for the amount of sugar content and maltodextrin concentrations in Tortilla samples are shown in Figure 118. The amount of sucrose, fructose, and total sugar decreased for all storage temperatures during 52 weeks storage; however, for samples stored at higher temperatures, the decrease occurred more rapidly, particularly for samples stored more than 8 weeks at 140°F. There were no considerable maltodextrin changes in the samples stored at 40 and 80°F, but exposure of samples to 100°F and above resulted in increases in maltodextrin concentration.

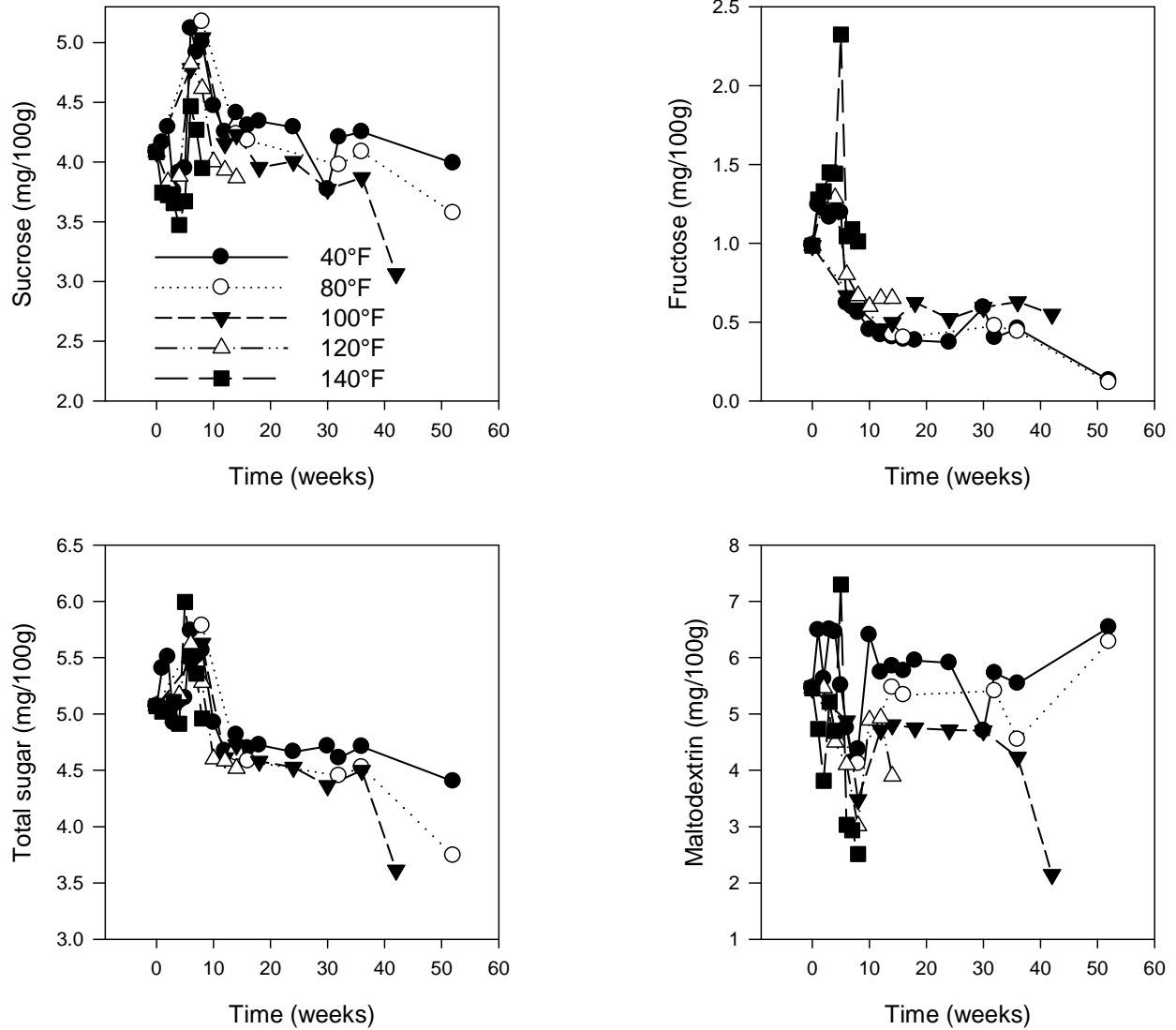

Figure 118. Changes in sugar profile (sucrose, fructose, and total sugar) and maltodextrin content of Tortillas during a 52-week storage period at 40, 80, 100, 120, and 140°F

Lipid Oxidation:

The magnitude of lipid oxidation was measured using peroxide value (PV) assay to monitor the primary oxidation products formed during 52 weeks storage at 40, 80, 100, 120, and 140°F. The degree of lipid oxidation fluctuated regardless of the storage time or temperature (Figure 119). The results showed that the level of lipid oxidation in Tortillas samples were low for all temperatures after 52 weeks storage. The lipid oxidation was not found to be a critical point regardless of storage temperature and time for Tortillas, considering a range of 7-30 meq/kg as the limit of acceptability reported in the literature for different foods (in Materials and Methods).

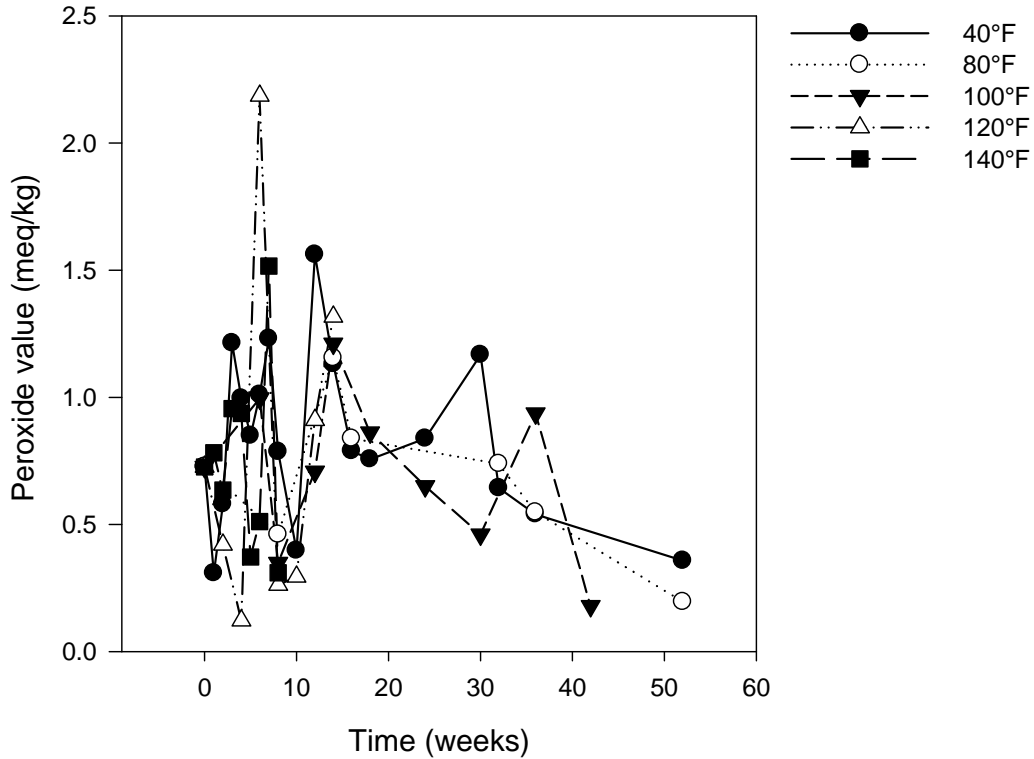

Figure 119. Changes in the peroxide value of Tortillas during storage for 52-weeks at 40, 80, 100, 120, and 140°F.

2.3.8 BBQ Beef Pocket Sandwich

2.3.8.1 Physical Characteristics

Color:

Exposure of BBQ Beef Pocket Sandwich to high temperatures (120 and 140°F) resulted in sharp decreases in L* value, hue angle, and chroma values (Figure 120). For example, samples stored at 140°F showed decreases of 46%, 39%, and 24% for L* value, hue angle, and chroma values, respectively. These samples exhibited dark brown appearance (Figure 121). In general, as the temperature and storage time increased, the sandwich samples became darker brown. Brown color development took place after 8 weeks storage at 120 and 140°F and was accelerated by time and temperature. The reaction for the brown color could have been caused by non-enzymatic browning as a result of exposure to extreme temperature conditions.

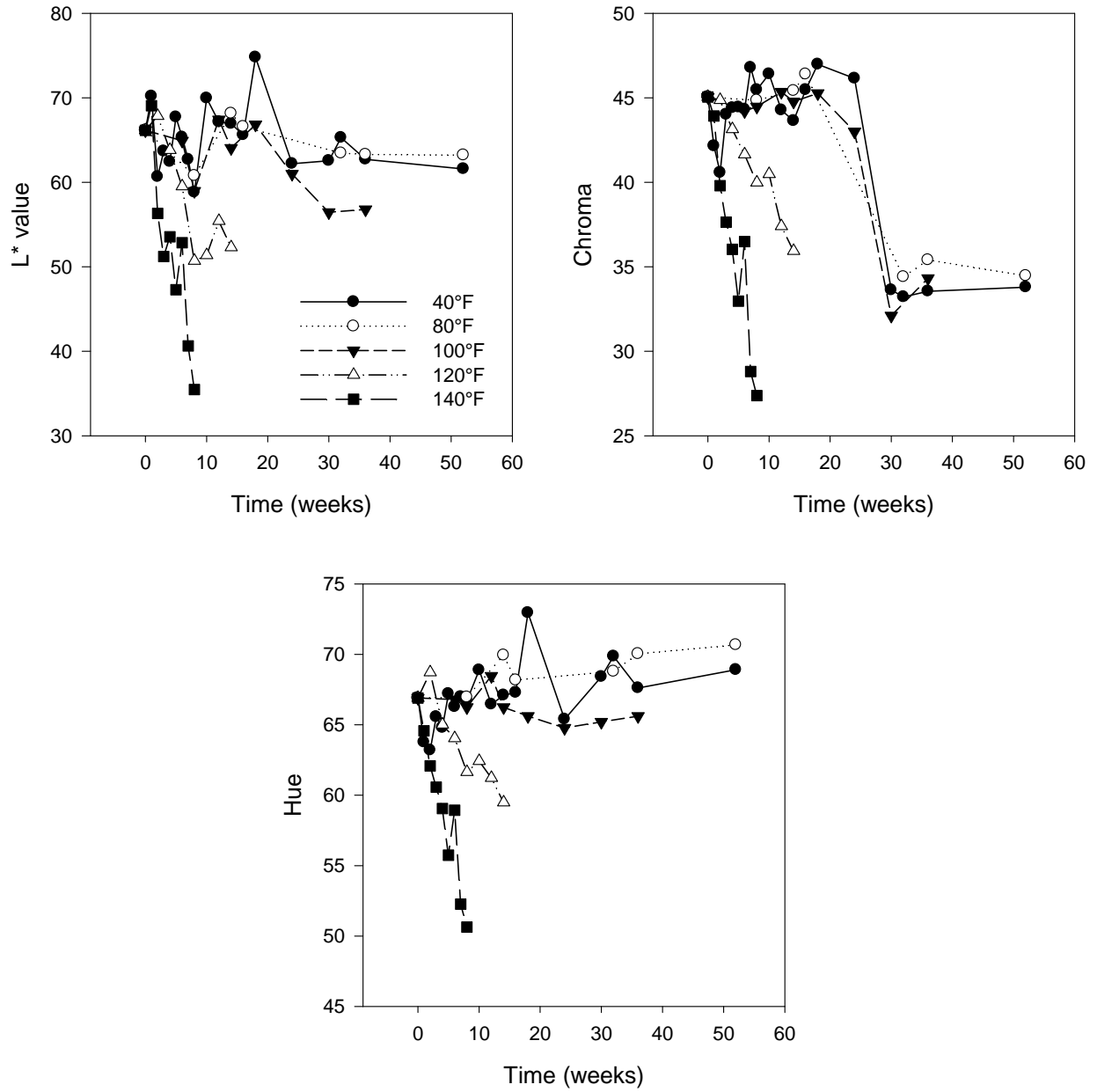

Figure 120. Changes in color attributes (L*, chroma, and hue) of BBQ Beef Pocket Sandwich during a 52-week storage period at 40, 80, 100, 120, and 140°F

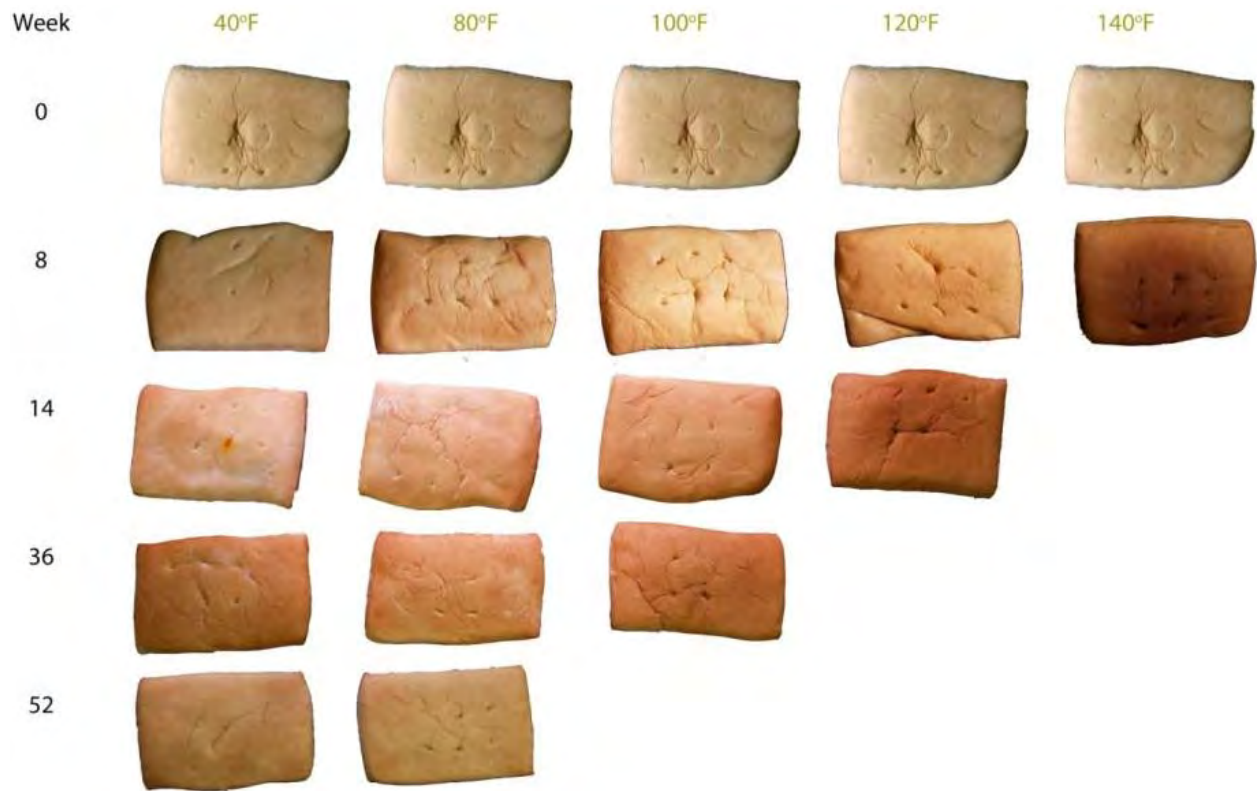

Figure 121. Changes in the appearance of BBQ Beef Pocket Sandwich during a 52-week period at 40, 80, 100, 120, and 140°F

Texture:

The BBQ Beef Pocket Sandwich samples stored at high temperatures (120 and 140°F) showed a considerable decrease in firmness values when compared with samples stored at other temperature conditions after 8 weeks storage (Figure 122). After 52 weeks, samples stored at 40 and 80°F had the lowest changes in texture when compared to initial texture measurement.

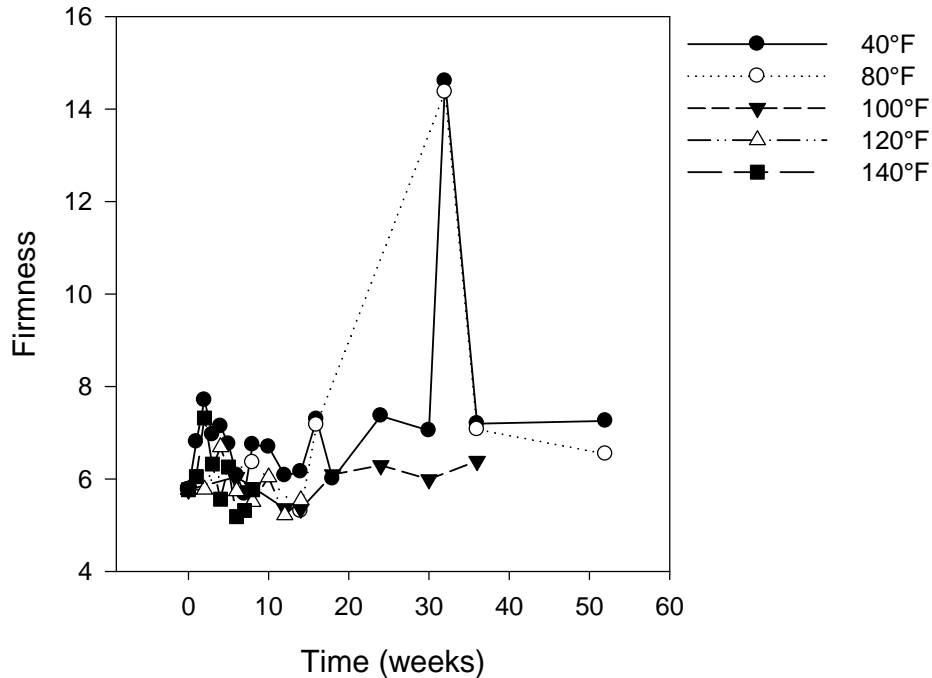

Figure 122. Changes in the texture of BBQ Beef Pocket Sandwich stored during a 52-week storage period at 40, 80, 100, 120, and 140°F

2.3.8.2 Compositional Analysis

Titratable Acidity, Soluble Solids Content, and pH:

As the storage temperature increased from 100 to 140°F, the pH of the BBQ Beef Pocket Sandwich started to decrease, titratable acidity increased, and total soluble solids content did not show major changes (Figure 123). The pH decreased for all storage temperatures during the 36-week storage period; however, in samples stored at high temperatures it decreased rapidly, particularly samples stored more than 8 weeks at 140°F. There were no considerable changes in titratable acidity for the samples stored at 40 and 80°F, but samples stored at 100°F and above showed an increase in titratable acidity. Soluble solids content increased sharply after 8 weeks of storage, but beyond this period there were no significant additional changes in soluble solid contents for samples stored at any temperature.

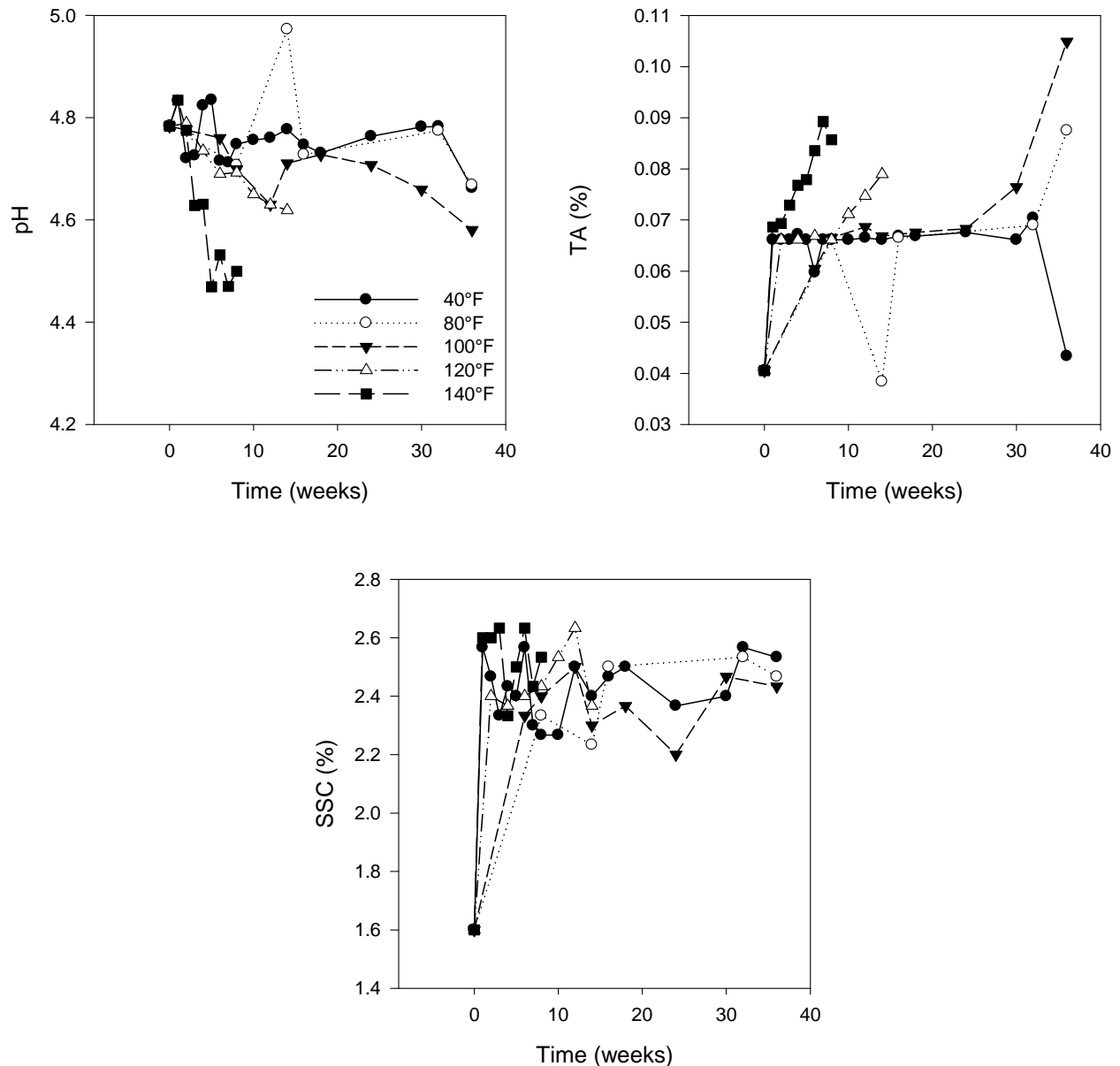

Figure 123. Changes in pH, titratable acidity, and soluble solid contents of BBQ Beef Pocket Sandwich during a 36-week storage period at 40, 80, 100, 120, and 140°F

Water Activity and Moisture Content:

The level of change in water activity and moisture content for the BBQ Beef Pocket Sandwich stored at different temperatures (40, 80, 100, 120, and 140°F) is shown in Figure 124. The water activity and moisture content fluctuated regardless of the storage time and temperature. In addition, the water activity increased for 8 weeks, after which the levels became constant for all temperatures. Overall, there was an increase in water activity and a decrease in moisture content for all temperatures as storage time and temperature were increased.

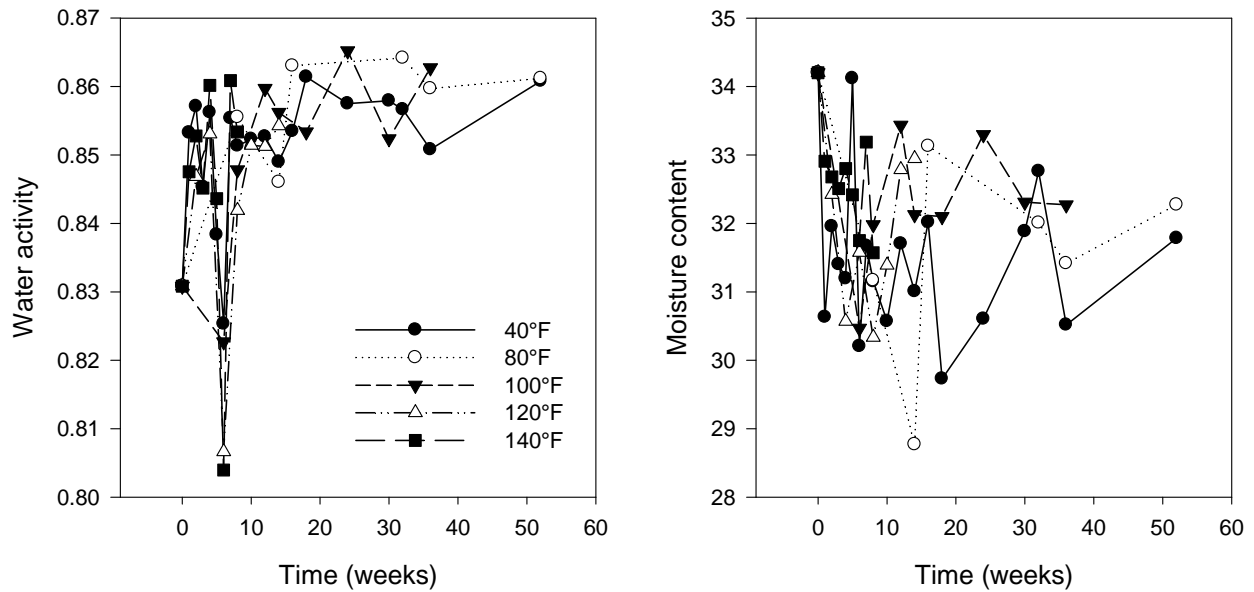

Figure 124. Changes in moisture content and water activity of BBQ Beef Pocket Sandwich during a 52-week storage period at 40, 80, 100, 120, and 140°F)

Ascorbic Acid Content:

Ascorbic acid content increased after 8 weeks storage regardless of temperature, but then showed a sudden decrease for the subsequent weeks (Figure 125). The initial increase in the ascorbic acid content of the samples, regardless of the temperature, might have been a consequence of the uneven distribution of ascorbic acids in the samples or might have resulted from the difficulty in the extraction process due to the complexity of the food matrix.

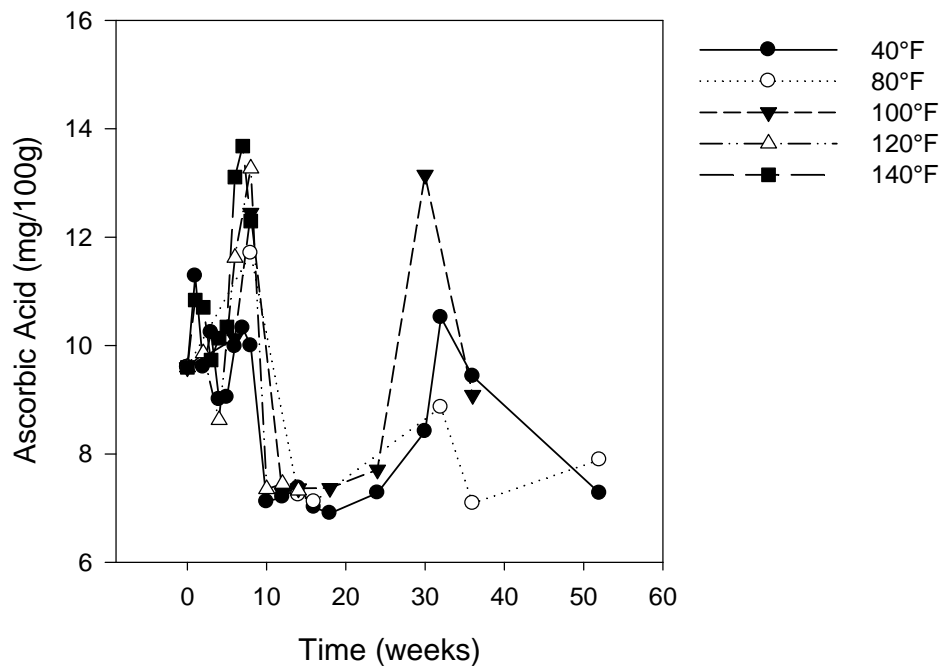

Figure 125. Changes in ascorbic acid content of BBQ Beef Pocket Sandwich during a 52-week storage period at 40, 80, 100, 120, and 140°F

Individual and Total Sugar Profiles:

Changes in sucrose, fructose, glucose, and total sugar contents for BBQ Beef Pocket Sandwich during 52 weeks storage at 40, 80, 100, 120, and 140°F are shown in Figure 126. While the amount of sucrose decreased, the amount of glucose and fructose increased for samples stored at 100°F or higher temperature. The effect of high temperature caused hydrolysis of sucrose into fructose and glucose (Figure 126). Similarly, the amount of total sugar concentration stored at 140°F had a minimum value compared to the other temperatures after 8 weeks storage. This could be degradation of sugars when exposed to high temperature.

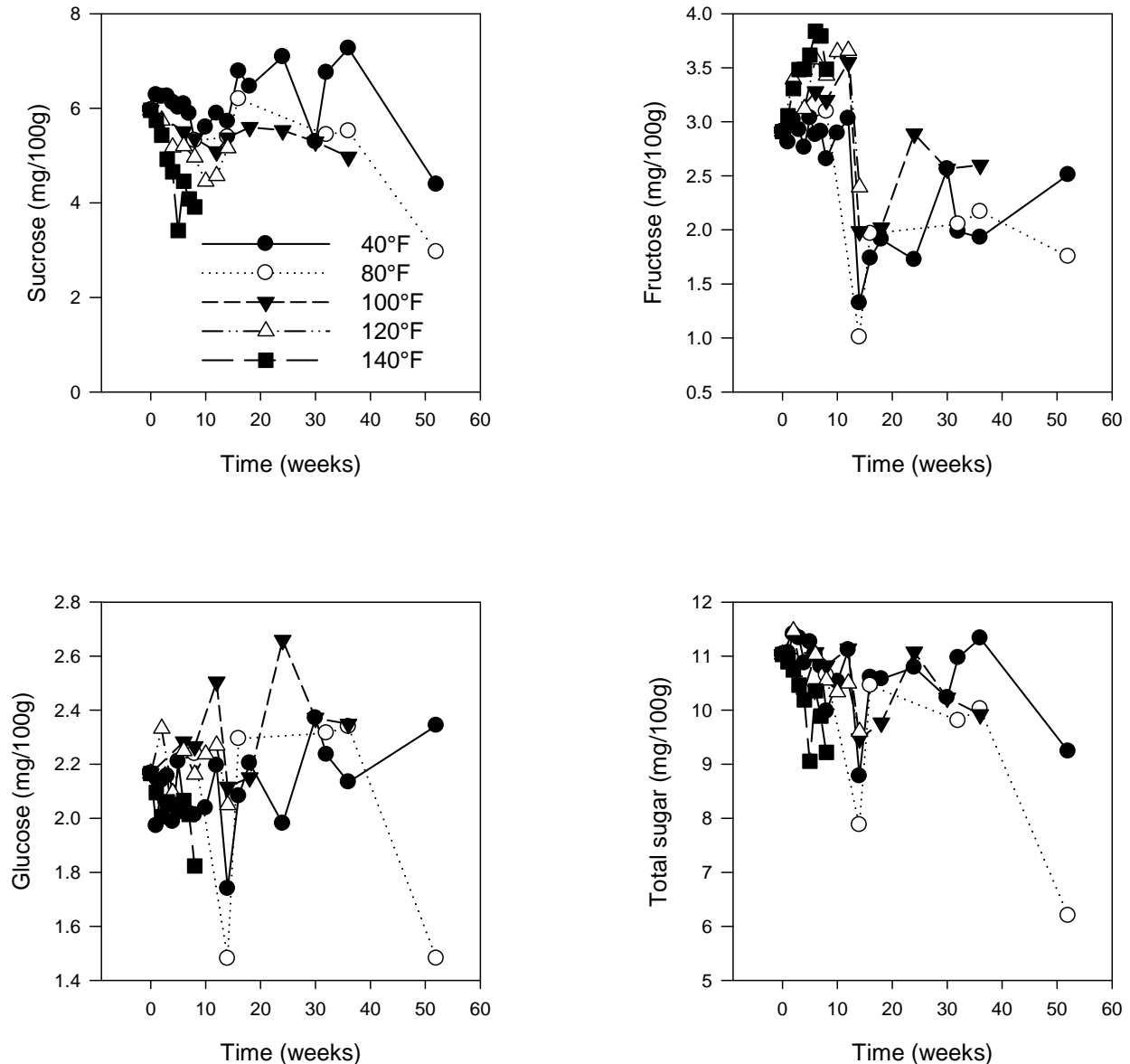

Figure 126. Changes in sugar profiles (sucrose, glucose, fructose, and total sugar) of BBQ Beef Pocket Sandwich during a 52-week storage period at 40, 80, 100, 120, and 140°F

Maltodextrin concentration showed a similar trend to that which was observed for total sugar content (Figure 127). Samples stored at 120 and 140°F showed significant decreases in the amount of maltodextrin after 8 weeks. The amount of maltodextrin showed minimum concentration for samples stored at 100°F after 36 weeks (Figure 127). There was no significant difference between samples stored at 40 and 80°F, however, after 36-52 weeks, samples stored at 80°F showed a decrease in maltodextrin concentration compared to samples stored at 40°F.

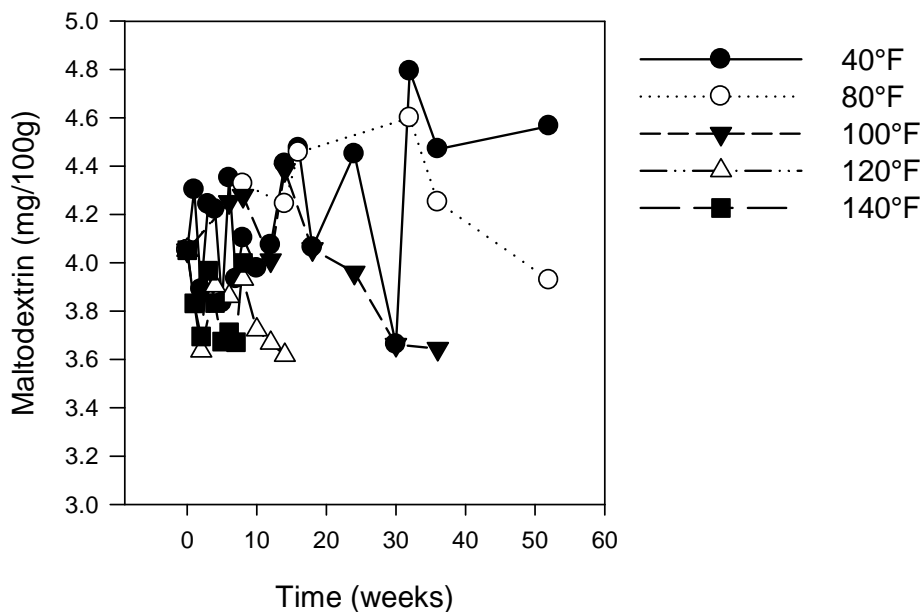

Figure 127. Changes in maltodextrin content of BBQ Beef Pocket Sandwich during a 52-week storage period at 40, 80, 100, 120, and 140°F

Lipid Oxidation:

Peroxide value (PV) assay was used to measure the level of lipid oxidation for the primary oxidation products formed. Because of the complexity of the food matrix and the meat distribution in this type of sandwich, there were two types of sampling methods used. In one, lipid oxidation was measured in the whole sandwich comprising bread and meat, and in the other lipid oxidation was measured in the meat part of sandwich only. In general, lipid oxidation values were higher in the meat part only than in the entire sandwich, except for samples stored at 80°F. Lipid oxidation in the whole sandwich decreased after 8 weeks storage regardless of temperature, but it showed a sudden increase during the subsequent weeks. The lipid oxidation in the meat part fluctuated regardless of the storage time or temperature (Figure 128). The level of lipid oxidation was reasonably low for all temperatures after 52 weeks storage and therefore it was not considered a critical quality issue.

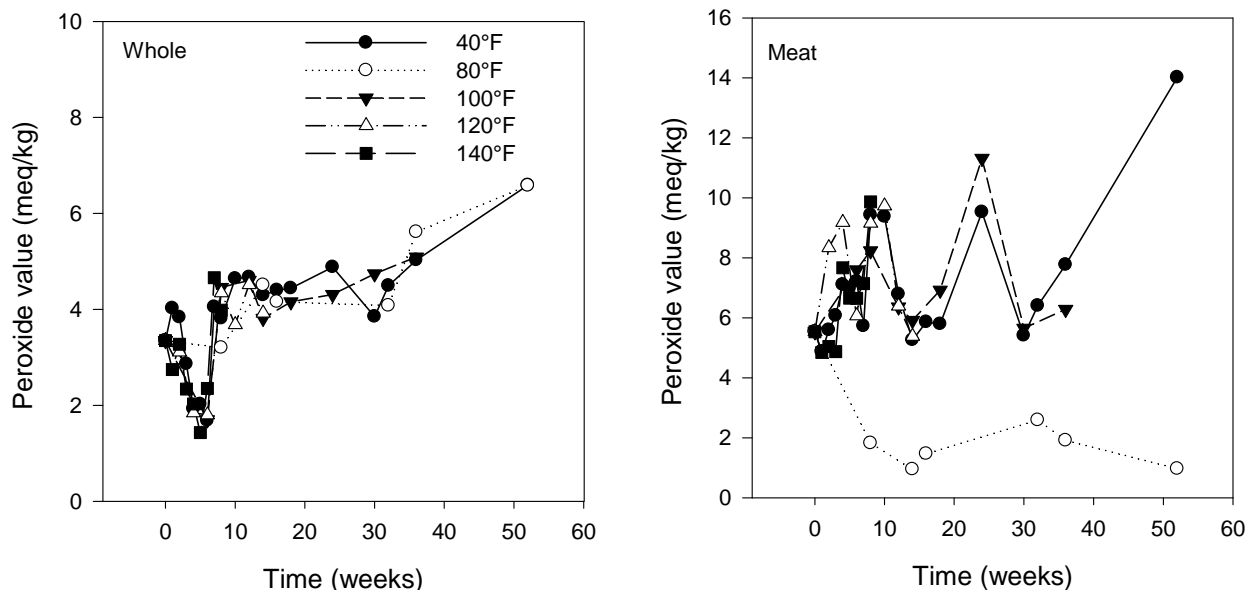

Figure 128. Changes in the peroxide value of whole and meat part only of BBQ Beef Pocket Sandwich during a 52-week storage period at 40, 80, 100, 120, and 140°F

2.3.9 Dessert Bar, Chocolate Banana Nut

2.3.9.1 Physical Characteristics

Color:

Dessert Bar, Chocolate Banana Nut stored at high temperature conditions (120 and 140°F) showed a sharp decrease in L* value, hue angle, and chroma value at the end of 8 weeks storage period (Figure 129). These changes resulted from a faded color and brittleness in the texture of chocolate banana nut dessert bar (Figure 130). In addition, samples stored at 40, 80, and 100°F show only slight increase in L* value after 52 weeks, but significantly decreased in chroma and hue value after 30 weeks storage. The lowest L* value was observed in the sample stored at 140°F at the end of 8 weeks.

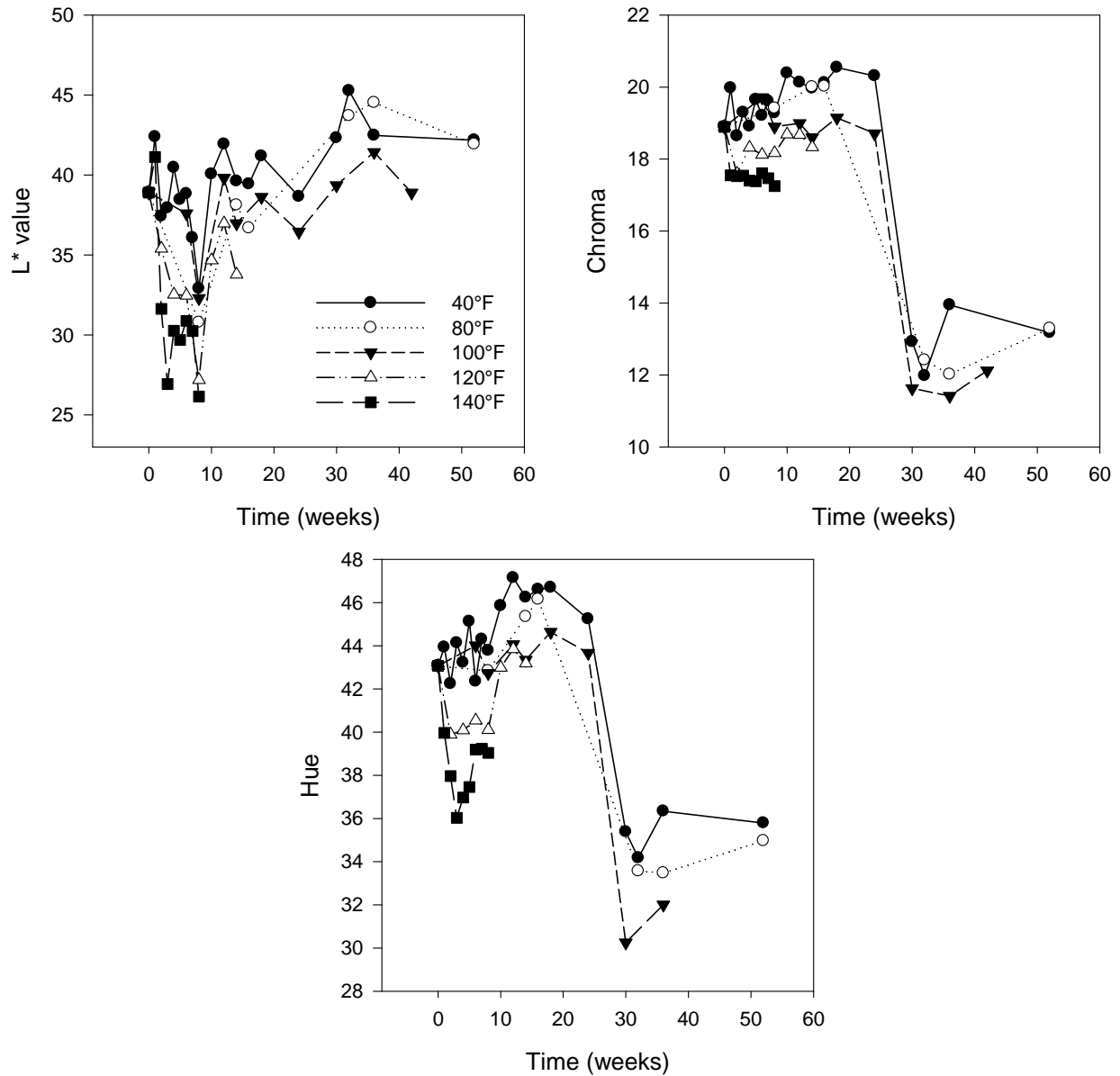

Figure 129. Changes in color attributes (L*, chroma, and hue) of Dessert Bar, Chocolate Banana Nut during a 52-week storage period at 40, 80, 100, 120, and 140°F

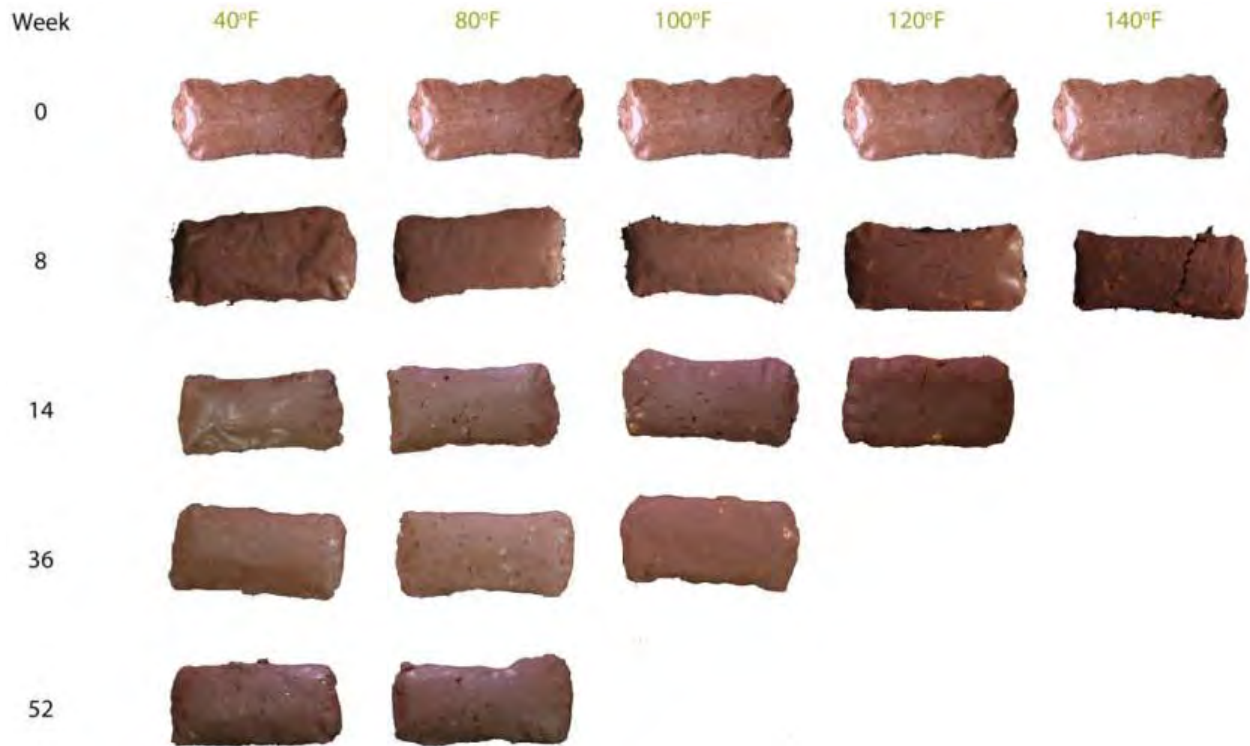

Figure 130. Changes in the appearance of Dessert Bar, Chocolate Banana Nut during a 52-week storage period at 40, 80, 100, 120, and 140°F

Texture:

Exposure of Dessert Bar, Chocolate Banana Nut to extreme temperature conditions (120 and 140°F) significantly decreased their firmness compared to exposure to other temperature conditions after 8 weeks storage (Figure 131). This could have been the result of softer tissue or sample degradation at the higher temperatures. Samples stored at 40°F and 80°F had minimum changes in texture compared to initial texture measurement during 52 weeks storage time. Although samples stored 100°F had the highest firmness value at the end of 8 weeks storage, firmness value of this sample fluctuated during the entire storage period.

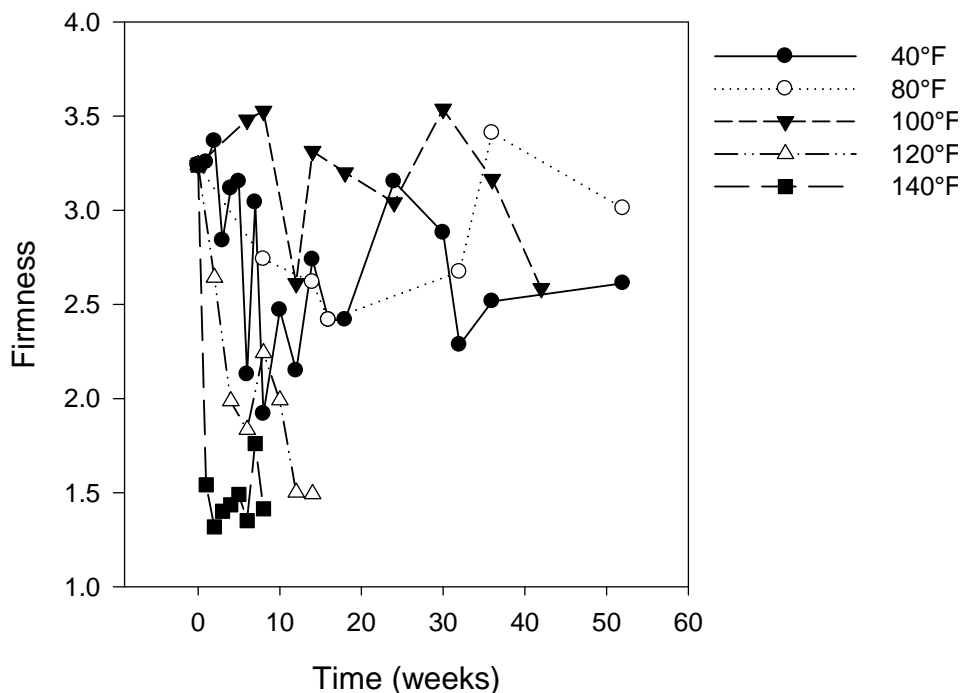

Figure 131. Changes in the texture of Dessert Bar, Chocolate Banana Nut during a 52-week storage period at 40, 80, 100, 120, and 140°F

2.3.9.2 Compositional Analysis

Titrateable Acidity, Soluble Solids Content, and pH:

The effect of different temperatures (40, 80, 100, 120, and 140°F) on pH, titrateable acidity, and total soluble solids contents for Dessert Bar, Chocolate Banana Nut during the 52-week storage period is shown in Figure 132. The pH decreased in samples from all storage temperatures during 36 weeks storage; however, pH of samples stored at higher temperatures decreased rapidly, particularly in samples stored at 140°F after storage of 8 weeks. Titrateable acidity increased as the temperature increased and also increased during storage. Titrateable acidity had the highest value for the sample stored at 140°F after 8 weeks storage. Soluble solids content increased regardless of the storage time and temperature when compared to initial measurement.

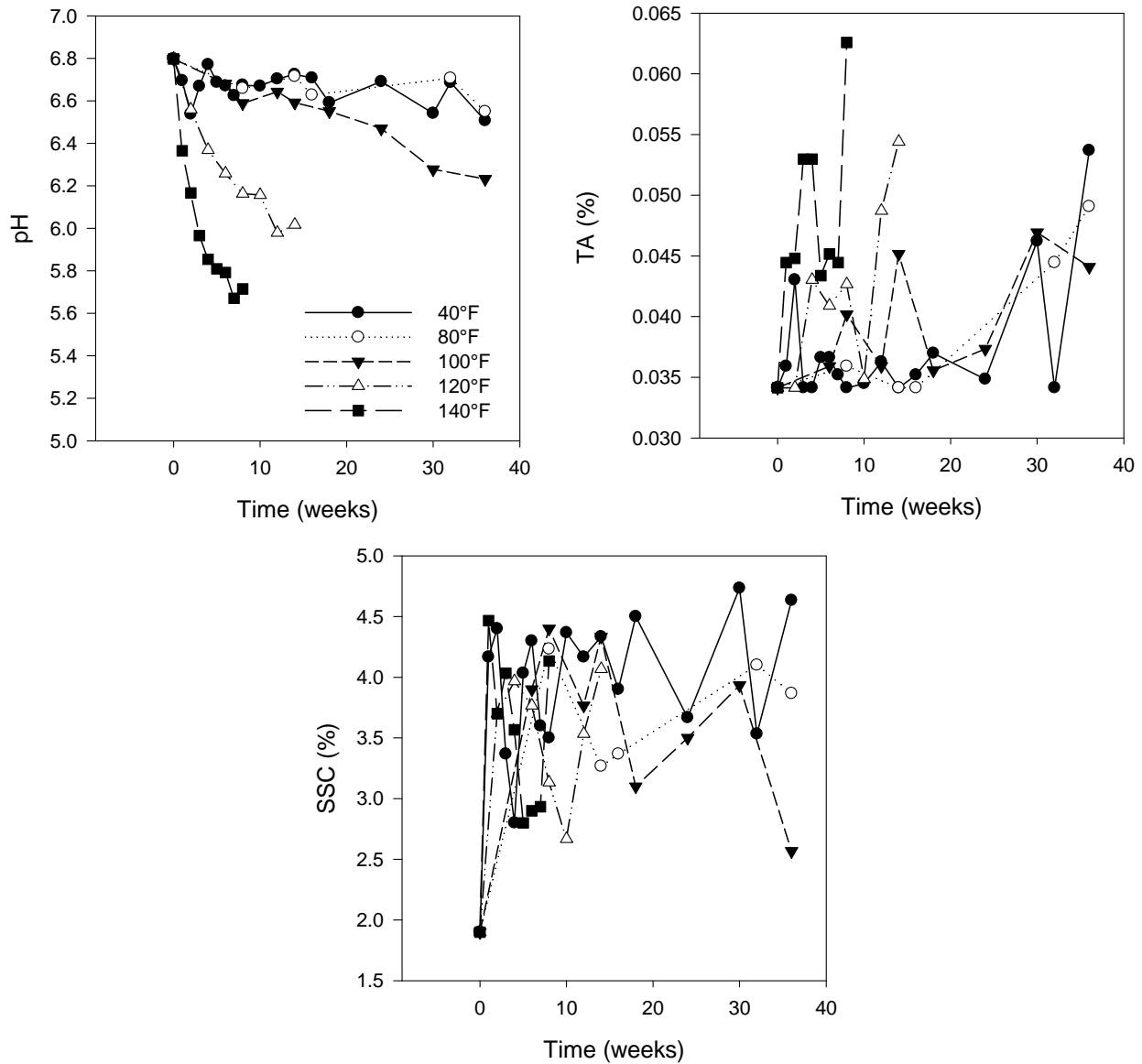

Figure 132. Change in pH, titratable acidity, and soluble solid contents Dessert Bar, Chocolate Banana Nut during a 36-week storage period at 40, 80, 100, 120, and 140°F

Water Activity and Moisture Content:

Changes in water activity and moisture content for Dessert Bar, Chocolate Banana Nut stored at different temperatures during 52 weeks are shown in Figure 133. Water activity and moisture content did not show a certain trend during storage. They fluctuated regardless of the storage time and temperatures. This could be considered normal since the moisture content was considerably low in Dessert Bar, Chocolate Banana Nut.

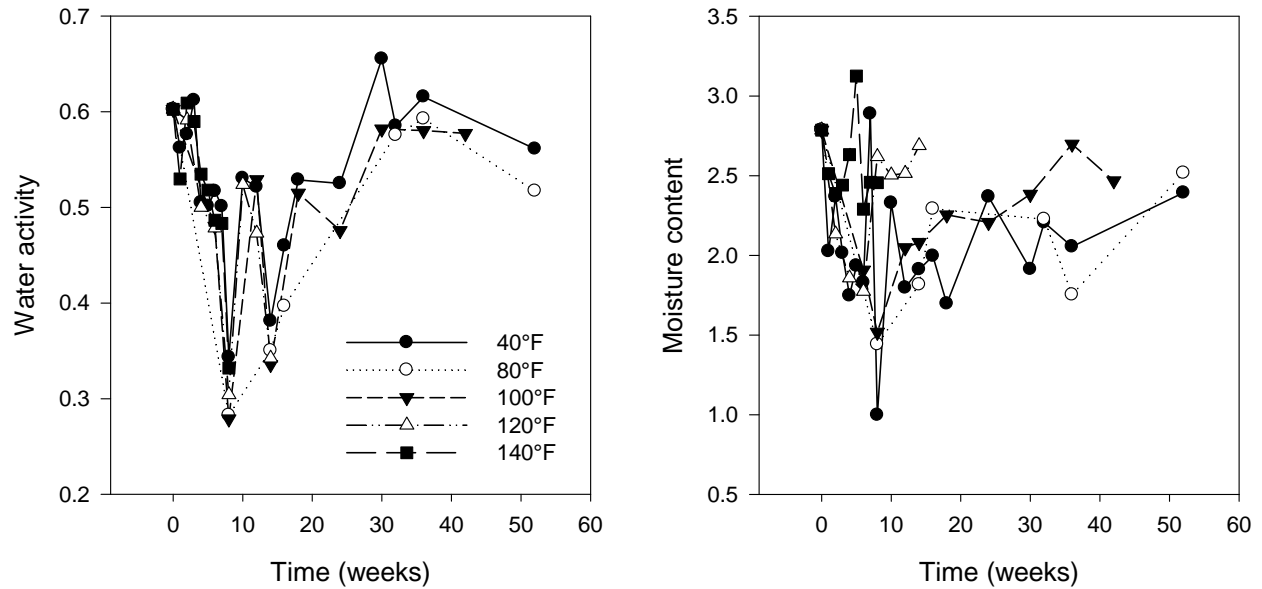

Figure 133. Changes in moisture content and water activity of Dessert Bar, Chocolate Banana Nut during a 52-week storage period at 40, 80, 100, 120, and 140°F

Individual and Total Sugar Profiles:

Dessert Bar, Chocolate Banana Nut initial total sugar content was primarily composed of sucrose (92.3%), glucose (5.4%), and fructose (2.3%). Exposure to high temperatures (120 and 140°F) resulted in a sudden decrease in the concentration of sucrose and glucose, particularly in samples stored at 140°F (Figure 134). However, samples stored at 40°F and 80°F did not show any major change in their sucrose and glucose concentrations during storage.

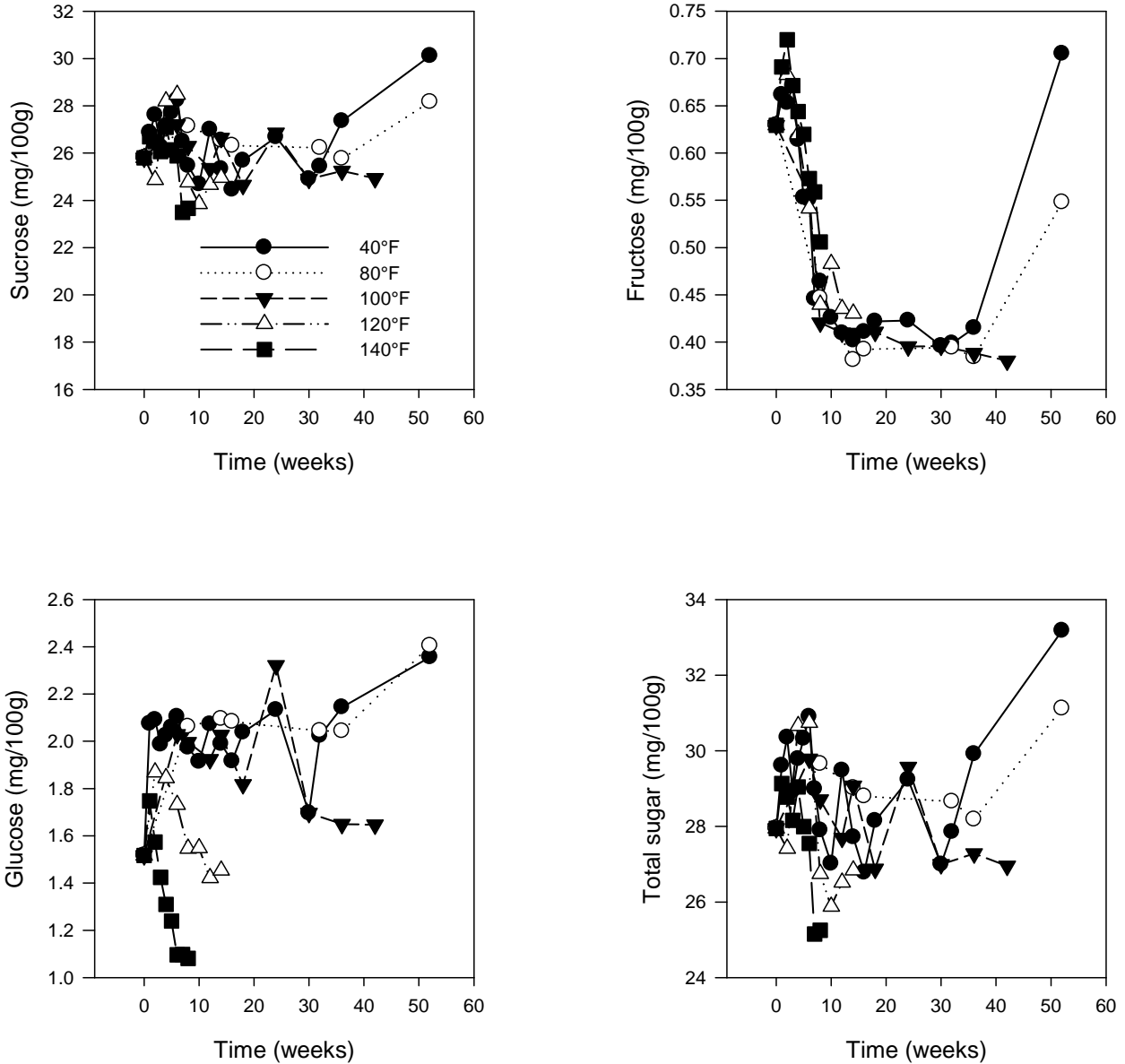

Figure 134. Changes in sugar profiles (sucrose, glucose, fructose, and total sugar) of Dessert Bar, Chocolate Banana Nut during a 52-week storage period at 40, 80, 100, 120, and 140°F

Lipid Oxidation:

The amount of lipid oxidation in the Dessert Bar, Chocolate Banana Nut was measured using peroxide value (PV) assay to monitor the primary oxidation products formed during 52 weeks storage at 40, 80, 100, 120, and 140°F. The degree of lipid oxidation fluctuated independently regardless of the storage time and temperature. The PV value increased slowly until week 14, after which it started to decrease. However, the level of lipid oxidation stayed moderately low for all temperatures after 52 weeks storage (Figure 135).

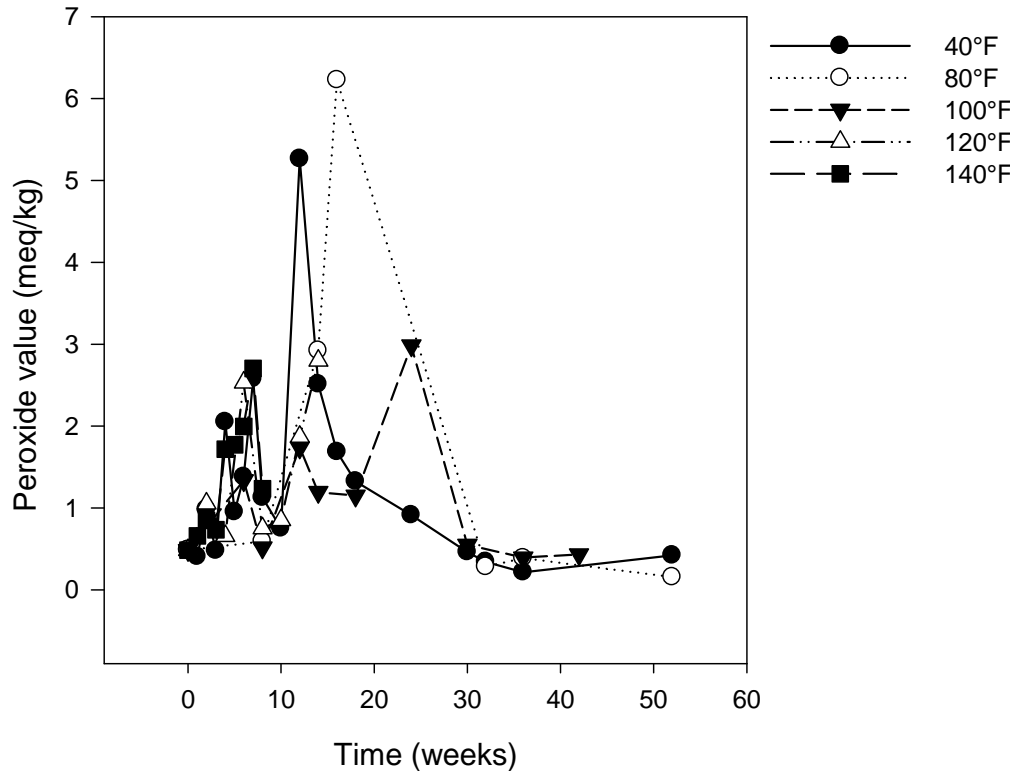

Figure 135. Changes in peroxide value of Dessert Bar, Chocolate Banana Nut during a 52-week storage period at 40, 80, 100, 120, and 140°F

2.4 General Conclusions

There were similar trends in the physical and compositional behavior and degradation during storage at refrigerated and non-refrigerated temperatures for of all nine FSR items evaluated (Filled French Toast Pocket, Bacon Cheddar Pocket Sandwich, Wheat Snack Bread, Beef Snack Sweet BBQ, Applesauce CHO Enhanced, Italian Pocket Sandwich, Tortillas, BBQ Beef Pocket Sandwich, Dessert Bar Chocolate Banana Nut), particularly when these were exposed to extreme temperatures, namely at 100, 120 and 140°F. Samples stored at lower temperatures (40 and 80°F) showed much slighter, or sometimes even very subtle, changes in their physical and compositional attributes, particularly samples stored under refrigerated conditions (40°F). Overall, when stored at 100, 120 or 140°F compared to storage at 80 and 40°F:

- ⇒ All FSR items showed marked changes in coloration translated by darkening of the color and development of a brownish or brownish dark color (decrease in L* values). The brownish appearance was attributed to a non-enzymatic browning reaction that might have occurred during exposure to high temperatures.
- ⇒ There was a considerable decrease in the firmness values (softening of the samples) of all items, except for Beef Snack, Sweet BBQ, which suffered an increase in firmness due to toughening of the food matrix when exposed to high temperatures.

- ⇒ In general, pH of all FSR items tended to decrease whereas acidity increased during storage and therefore the food items tended to have a higher acid content than before storage. Regarding soluble solids content of the samples, there was not a common trend but in most cases there was either an increase or no major changes that occurred during storage.
- ⇒ All FSR items showed an increase in water activity and a decrease in moisture content, except for Dessert Bar, Chocolate Banana Nut, which showed very low water activity compared to the other items. The increase in water activity reflected rearrangements in the food matrix with loss of water paralleling these changes.
- ⇒ Although there was not a similar trend between the nine FSR items in terms of sugar profile, in general, total sugar content tended to decrease. This was mainly due to a decrease in sucrose concentration (the main sugar in most items), and increases in glucose and fructose concentrations, which was attributed to the hydrolysis of sucrose into fructose and glucose. The total sugar concentration of Filled French Toast Pocket was an exception and samples stored at 140°F had higher total sugar content than those stored at lower temperatures. This was attributed to the concentration effect due to water loss during storage at high temperature.
- ⇒ Ascorbic acid content was measured only in samples that contained ascorbic acid in considerable amounts, which included Bacon Cheddar Pocket Sandwich, Applesauce, Italian Pocket Sandwich, and BBQ Beef Pocket Sandwich. In general, there was only a slight change in the amount of the ascorbic acid of samples stored at 40°F. However, as the temperature increased, the degradation of total ascorbic acid during storage was striking, particularly for Applesauce.
- ⇒ The lipid oxidation values (PV values) in FSR items were not found to be critical considering the limits of acceptability reported in the literature for different foods. This was possibly due to the low permeability of the packages to oxygen, which prevented the entrance of air and therefore the oxidation of the fat content of the samples. However, when the lipid oxidation of the meat was analyzed separately from the bread (in sandwiches containing meat) the PV values were higher in the meat.

2.5 Objective 2 Literature Cited

1. Balasubramanyam N., Baldev Raj, Indiramma A.R. 1983. Packaging and storage quality of roasted and salted spiced peanuts in flexible packages. *Perfectpac* 23, 5-11, *Food Science and Technology Abstracts*, 16, 6F300.
2. Calligaris S., Manzocco L., Kravina G., Nicoli M.C. 2007. Shelf life modelling of bakery products by using oxidation indexes. *J Agric Food Chem* 55(5), 2004-2009.
3. Calligaris S., Pieve S.D., Kravina G., Manzocco L., Nicoli C.M. 2008. Shelf life prediction of bread sticks using oxidation indices: A validation study. *Journal of Food Science* 73(2), E51–E56.
4. Evranuz E.O. 1993. The effect of temperature and moisture content on lipid peroxidation during storage of unblanched salted roasted peanuts: shelf life studies for unblanched salted peanuts. *Int. J. Food Sci. Technol.* 28, 193-199.
5. Huss H.H. 1988. *Fresh fish quality and quality changes*. Rome, Italy: FAO.
6. Narasimhan S., Raghuver K.G., Arumugham C., Bhat K.K., Sen, D.P. 1986. Oxidative rancidity of groundnut oil evaluation by sensory and chemical indices and their correlation. *Journal of Food Science and Technology, India*, 23, 273-277. *Food Science and Technology Abstracts*, 19, 6N21.
7. St. Angelo, A.J., Kuck, J.C., Hensarling, T.P., Ory, R.L. 1977. Effects of water and spin blanching on oxidative stability of peanuts. *Journal of Food Processing and Preservation* 1, 249-260.

3 Objective 2b: Sensory Attributes of FSR Items During Storage at Different Temperatures³

3.1 Introduction

A major goal of this project was to develop a knowledge base for the changes in food quality of First Strike Rations (FSR) as a function of time and temperature in the DoD supply chain. In order to determine their shelf life, samples of FSR menu items were evaluated by a trained descriptive sensory panel. Sensory quality of ration components was determined for various storage intervals and temperature conditions in order to provide data for the development of computer shelf life models by the project's Objective 1 team.

3.2 Materials and Methods

For the sensory evaluation of the nine selected FSR menu items, panelists were recruited based on their availability and ability to discriminate between stored and fresh processed foods. Sixteen panelists who qualified for participation were trained to become familiar with the FSR being studied as well as to determine the decline in their quality during storage. The panelists met three times to taste nine samples stored at 120°F at 2 weeks, 4 weeks, 5 weeks, 6 weeks and 8 weeks.

The samples were evaluated on a 1-9 scale based on how they compared to the controls stored under frozen (Filled French Toast, Italian Style Sandwich, Honey Barbecued Beef Sandwich, Bacon Cheddar Sandwich) or refrigerated conditions (Beef Snack BBQ, Zapplesauce, Chocolate Banana Nut Dessert Bar, Wheat Snack Bread, Tortilla). The choice of frozen vs. refrigerated temperature for control samples was based on communication with the researchers at NSRDEC. This scale was selected to closely follow the one being used at NSRDEC for similar purposes (S. Moody, personal communication).

Figure 136 shows a segment of a typical ballot used during training. Paper ballots were preferred during training to encourage discussion and sharing of sensory experiences. Towards the end of the training phase, the panelists were allowed to work on and familiarize themselves with the computerized ballots (Figure 137).

³ Prepared by: Asli Obadası, Ph.D., University of Florida, Gainesville, FL

TESTER:						DATE:			
PRODUCT: First Strike Rations									
INSTRUCTIONS: Please indicate number for quality scores in the box and make comments in the remaining space.									
REJECT			BORDERLINE			ACCEPT			
Extremely Poor	Very Poor	POOR	Below Fair Above Poor	Fair	Below Good Above Fair	Good	Very Good	Excellent	
1	2	3	4	5	6	7	8	9	
SAMPLE	APPEARANCE	ODOR	FLAVOR	TEXTURE	OVERALL QUALITY				
Zapplesauce Reference									
Zapplesauce Sample									

Figure 136. Ballot used during training sessions.

Zapplesauce, Beef Snack BBQ, Tortilla, Bacon Cheddar Sandwich, and Honey Barbecued Beef Sandwich were deemed unacceptable by the panelists and removed from 120°F storage into their respective control temperatures at 8 weeks. Samples of Chocolate Banana Nut Dessert Bar, Filled French Toast, Wheat Snack Bread and Italian Style Sandwich were tasted once more at 10 weeks, at which time they were found to be unacceptable.

Practice sessions followed in which three samples were presented for each product: 1) A control sample (stored under frozen or refrigerated conditions), 2) a sample that had clearly deteriorated to an unacceptable quality level, and 3) a sample in-between the “good” and the “bad” samples.

3.2.1 Reference Generation

In order to provide the panelists with examples of what constitutes an acceptable product and an unacceptable product throughout the course of the storage study, references were generated. Products were stored at 120°F for 10 weeks to make sure all of the nine FSR menu items had deteriorated to a clearly unacceptable level of quality. Products were then moved to their control temperatures (frozen temperature for Filled French Toast, Italian Style Sandwich, Honey Barbecued Beef Sandwich, Bacon Cheddar Sandwich and refrigerated temperature for Beef Snack BBQ, Zapplesauce, Chocolate Banana Nut Dessert Bar, Wheat Snack Bread, Tortilla). These references were the “bad references”.

Products that were kept at their control temperatures (frozen temperature for Filled French Toast, Italian Style Sandwich, Honey Barbecued Beef Sandwich, Bacon Cheddar Sandwich and refrigerated temperature for Beef Snack BBQ, Zapplesauce, Chocolate Banana Nut Dessert Bar, Wheat Snack Bread, Tortilla) were used as “good references”.

The two references were provided to the panelists each time they evaluated a given product from the storage study.

3.2.2 Evaluation of Stored Samples

During a sampling week, products were removed from high temperature storage and evaluated over the course of 3 days to minimize sensory fatigue. The panelists rated the quality of appearance, odor, flavor, texture and overall quality of three samples along with the good and bad references and as such tasted nine products in total each day. The panelists were required to take a 3 minute break in between tasting each product category by use of a computerized ballot that would not advance to the next screen before the countdown finished. Water was provided to cleanse their palates. The panelists were only told the name of the products they were evaluating and had no knowledge of the storage temperature or the storage time being studied. Figure 137 is a view of the computerized ballot. This screen would be followed by another on which the panelist commented on the samples. Figure 138 shows one of the two groups of panelists evaluating the products.

CHOCOLATE BANANA NUT DESSERT BAR
 Please indicate number for quality scores on the scale below by marking the line.
 999 IS THE GOOD REFERENCE and 000 IS THE BAD REFERENCE.

Appearance. 999 000 726

Odor.

Flavor.

Texture.

Overall.

Overall for Sample 726

Extremely Poor-1	Very Poor-2	Poor-3	Below Fair Above Poor-4	Fair-5	Below Good Above Fair-6	Good-7	Very Good-8	Excellent-9
------------------	-------------	--------	-------------------------	--------	-------------------------	--------	-------------	-------------

7.4

Next Question Question 1 of 2

Figure 137. A screen shot of a typical ballot used for the evaluation of stored FSR.



Figure 138. A group of trained panelists evaluating First Strike Ratios.

Sampling frequency (Table 17) at each temperature was determined based on estimates of total storage time making sure each product would be tested 4 or 5 times before deterioration. Point of deterioration was defined as the first point in time after which the mean overall (and any other attribute) quality score was below 4.0 twice in two consecutive sampling times. This boundary is shown on each sensory quality plot in Figure 148 through Figure 164. Although this quality rating for a failing product is lower than what is used at NSRDEC, the panelists were trained to have a uniform and consistent understanding of what constitutes a failing product.

Table 17. Frequency of sampling at each storage temperature

Storage Temperature (°F)	Sampling Frequency
80	Every 16 weeks
100	Every 6 weeks
120	Every 2 weeks
140	Every week

3.3 Results

3.3.1 80°F Storage

Nine FSR products (Filled French Toast, Italian Style Sandwich, Honey Barbecued Beef Sandwich, Bacon Cheddar Sandwich, Beef Snack BBQ, Zapplesauce, Chocolate Banana Nut Dessert Bar, Wheat Snack Bread, and Tortilla) were sampled from the 80°F storage temperature every 16 weeks. The mean quality scores were calculated and are summarized in Figure 110-118.

As expected, based on the shelf life requirement of 2 years at 80°F, within 64 weeks of storage, none of the products stored at this temperature deteriorated to a mean quality score of 4.0, which was agreed to be the cut-off for product rejection. The study of storage at 80°F is ongoing and sampling at this temperature will continue in Phase 2 for a total of 104 weeks.

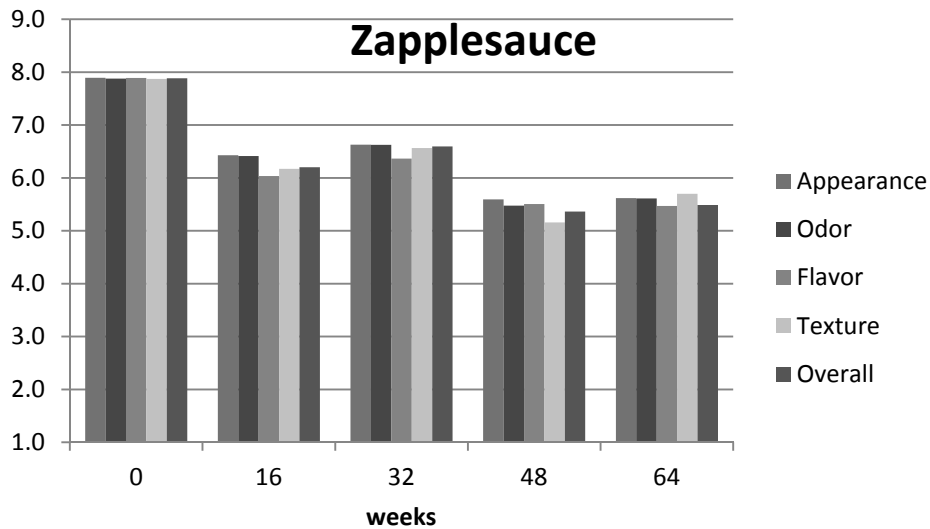

Figure 139. Changes in the quality attributes of Zapplesauce stored at 80°F

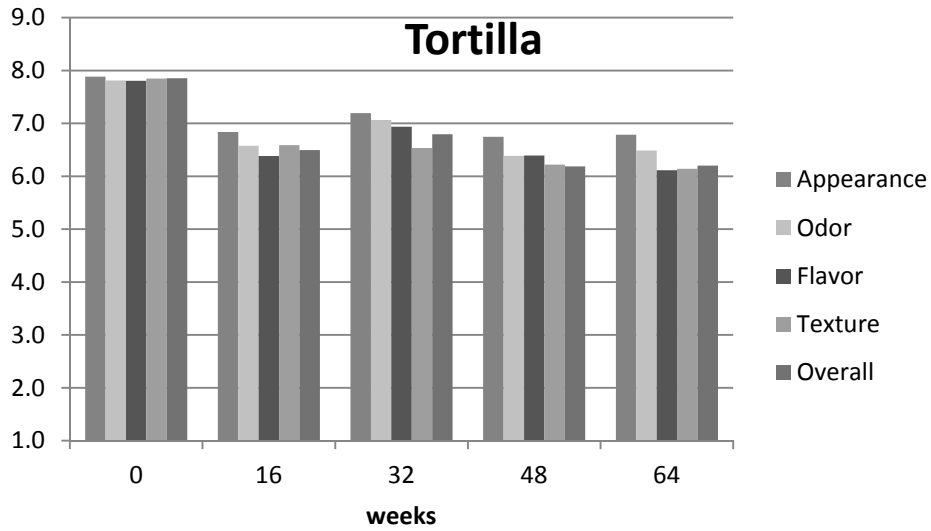

Figure 140. Changes in the quality attributes of Tortilla stored at 80°F

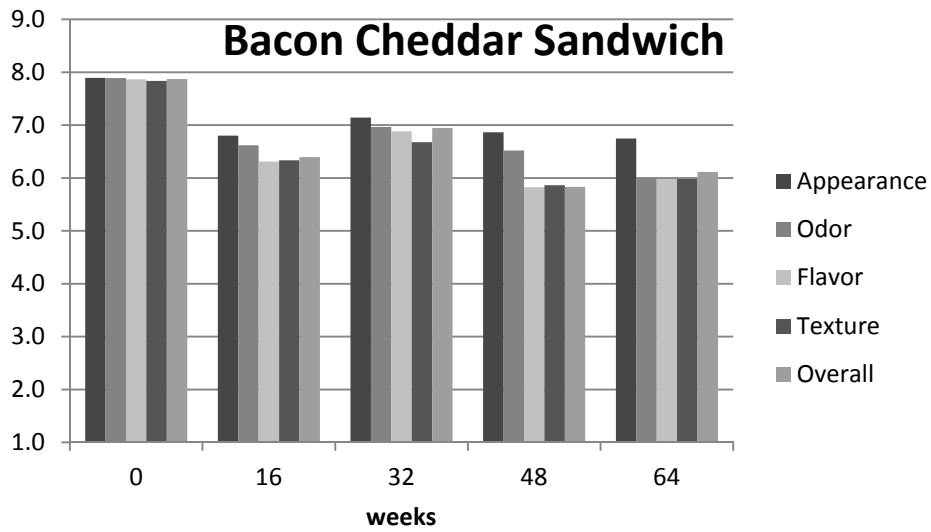

Figure 141. Changes in the quality attributes of Bacon Cheddar Sandwich stored at 80°F

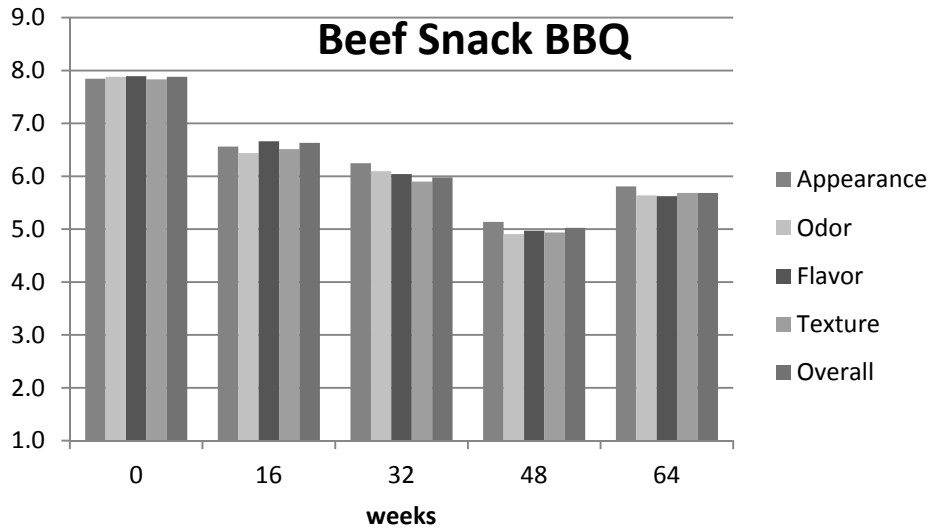

Figure 142. Changes in the quality attributes of Beef Snack Barbecue stored at 80°F

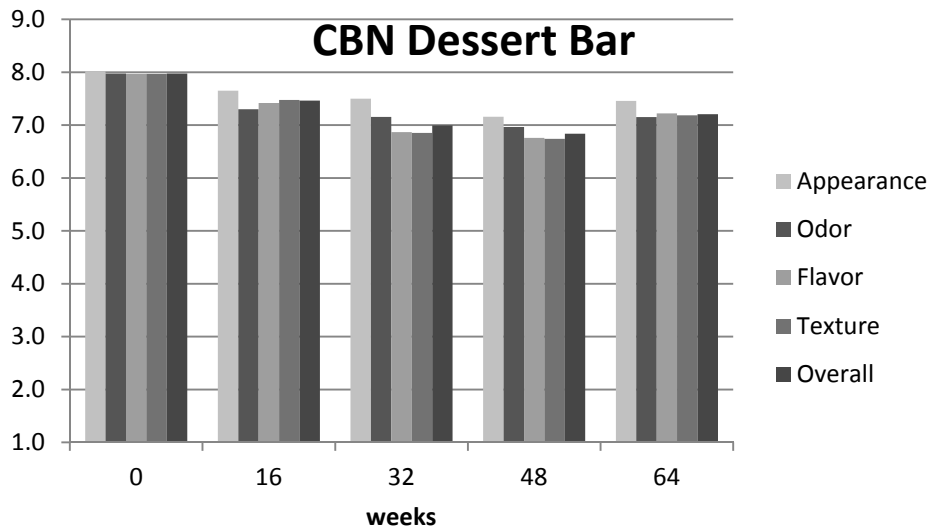

Figure 143. Changes in the quality attributes of Chocolate Banana Nut Dessert Bar stored at 80°F

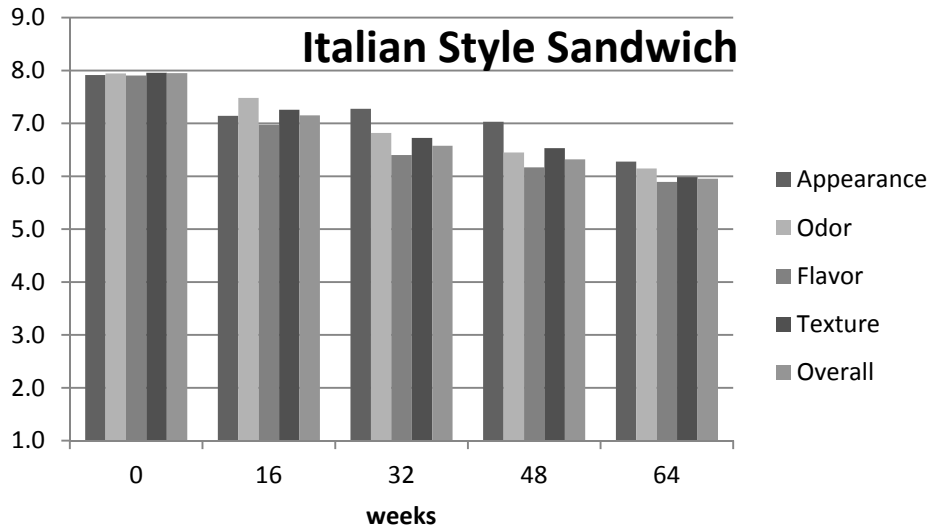

Figure 144. Changes in the quality attributes of Italian Style Sandwich stored at 80°F

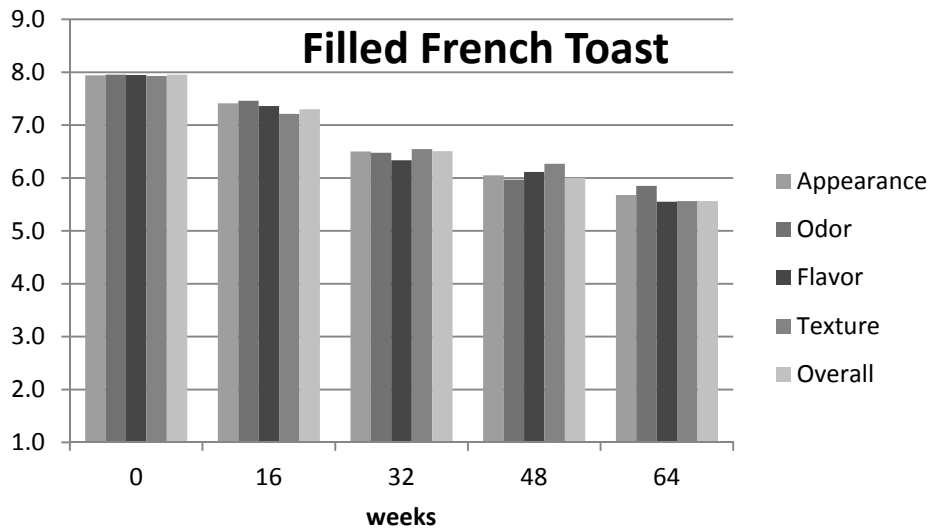

Figure 145. Changes in the quality attributes of Filled French Toast stored at 80°F

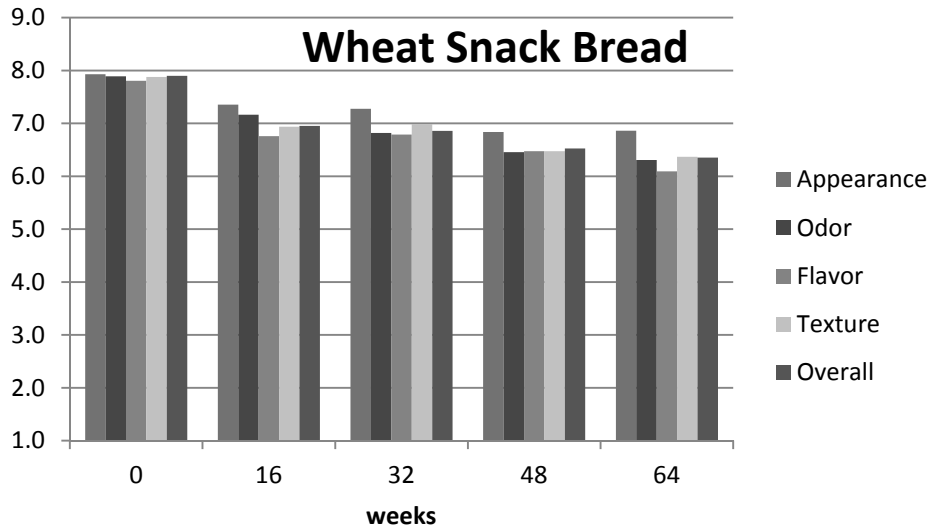

Figure 146. Changes in the quality attributes of Wheat Snack Bread stored at 80°F

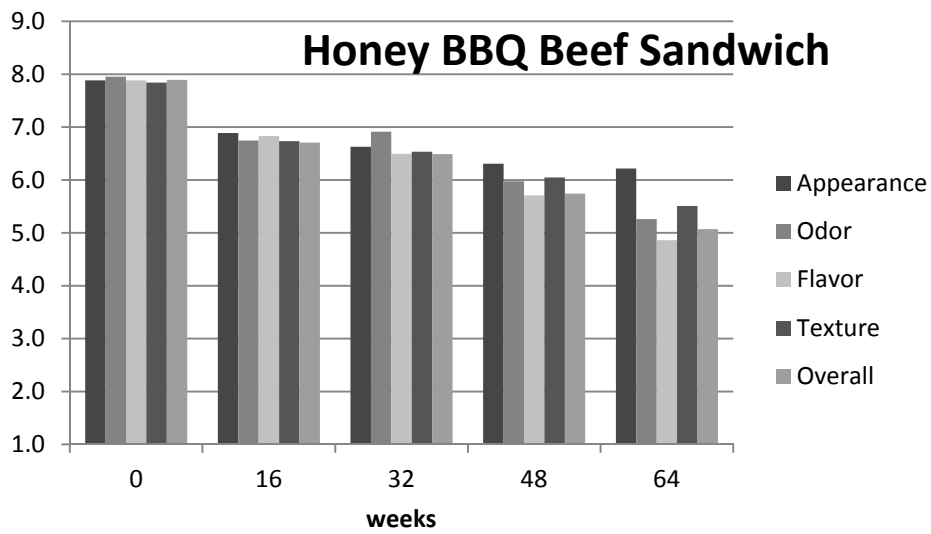

Figure 147. Changes in the quality attributes of Honey Barbecued Beef Sandwich stored at 80°F

3.3.2 100°F Storage

Nine FSR products (Filled French Toast, Italian Style Sandwich, Honey Barbecued Beef Sandwich, Bacon Cheddar Sandwich, Beef Snack BBQ, Zapplesauce, Chocolate Banana Nut Dessert Bar, Wheat Snack Bread, Tortilla) were sampled from the 100°F storage chamber every 6 weeks for from 36 to 48 weeks at which time they were found to have deteriorated to unacceptable levels. None of the products were deemed failing before the shelf life requirement of 6 months at this temperature. The mean quality scores were calculated and are summarized in Figures 148-156.

Zapplesauce, BBQ Beef Snack, Filled French Toast, Bacon Cheddar Sandwich, Italian Style Sandwich and Honey Barbecued Beef Sandwich samples were removed from the 100°F chamber at the end of 36 weeks. Tortilla and Wheat Snack Bread samples were kept for 6 more weeks and removed from 100°F storage at 42 weeks. The Chocolate Banana Nut Dessert Bar was removed from storage at this temperature at 48 weeks. Storage for this product was terminated not because the quality eventually dropped below a mean value of 4.0 for any attribute, but because the change in quality scores over the last 12 weeks of storage was minimal.

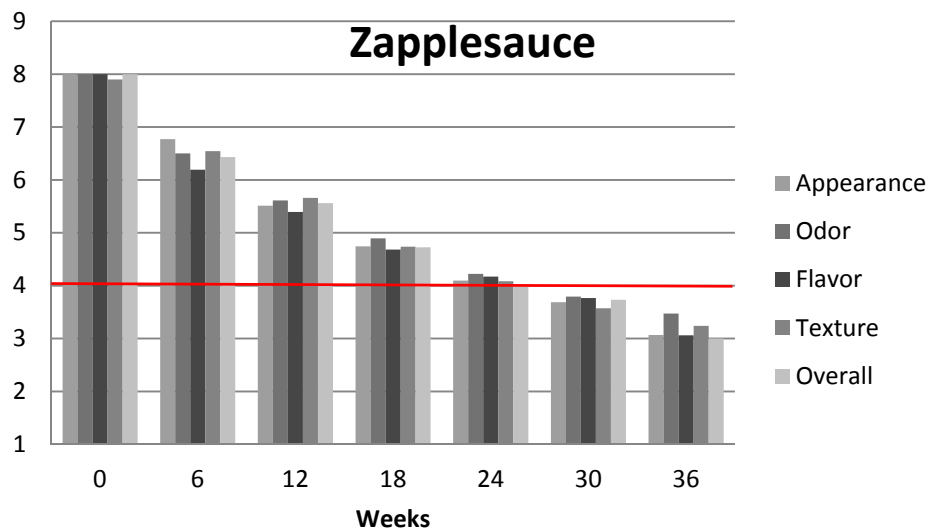

Figure 148. Changes in the quality attributes of Zapplesauce stored at 100°F

Zapplesauce got darker and thinner with time at 100°F and developed a stale, cardboardy aroma. Panelists picked up these changes as early as the 12th week but did not necessarily find the product unacceptable until the 30th week. Some of the panelists mentioned they were not bothered by the darkened applesauce, which reminded them of the cinnamon flavored kind they are used to eating.

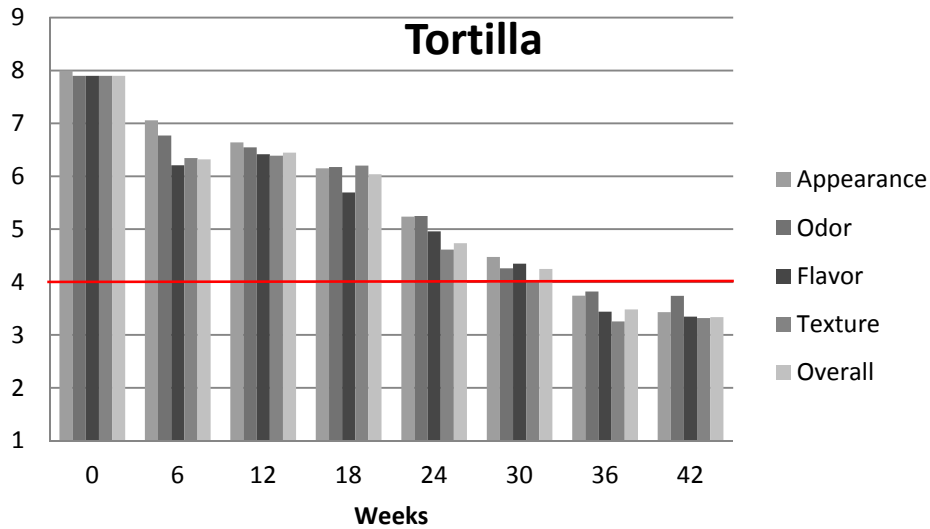

Figure 149. Changes in the quality attributes of Tortilla stored at 100°F

Tortilla samples lost their flexibility and broke when folded upon storage. This failure made the product unacceptable after 30 weeks of storage at 100°F. Other changes included a more yellow and oily appearance and a bitter taste, which were obvious later on during the storage.

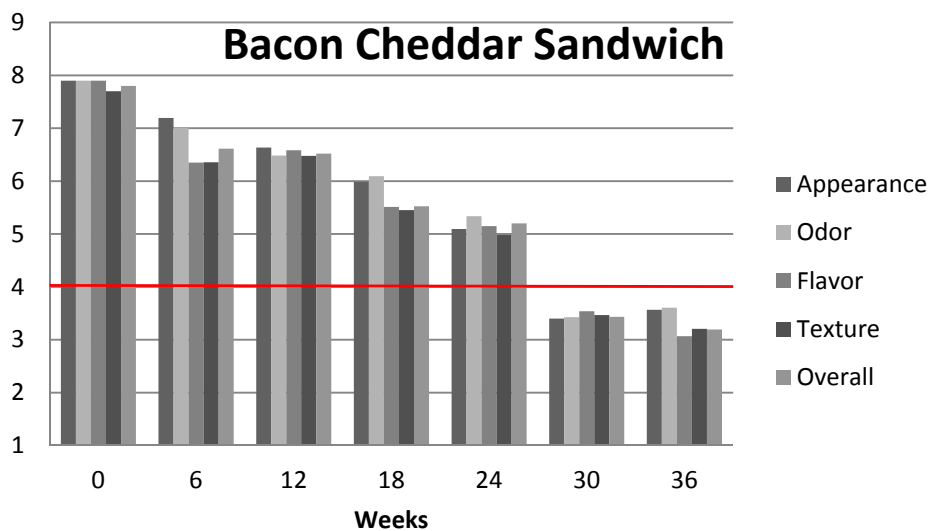

Figure 150. Changes in the quality attributes of Bacon Cheddar Sandwich stored at 100°F

Bacon Cheddar Sandwich became unacceptable around 30 weeks of storage at 100°F due to off-flavor formation, brittle bacon, and crumbly bread.

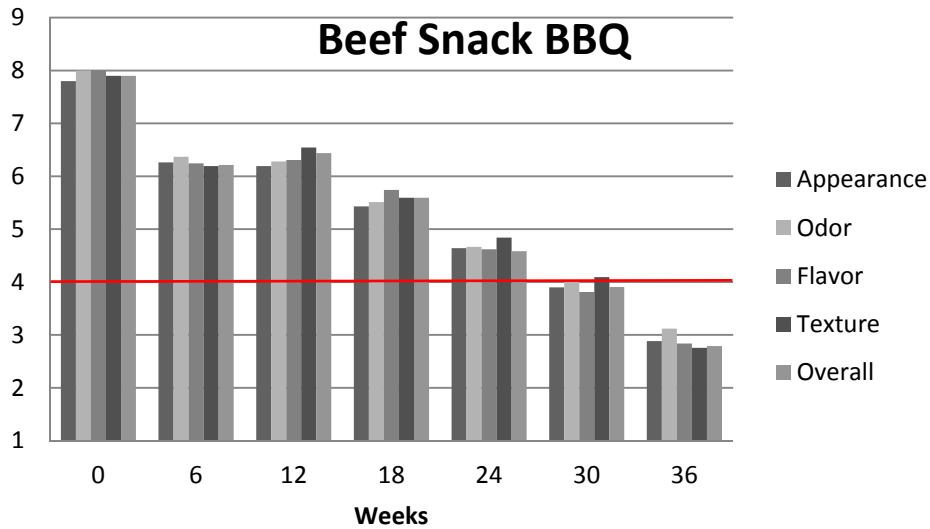

Figure 151. Changes in the quality attributes of Beef Snack BBQ stored at 100°F

Barbecue flavored beef snacks became harder and darker during storage at 100°F. The panelists reported oily surface, less barbecue flavor and gritty texture for the samples sampled at 30 weeks of storage.

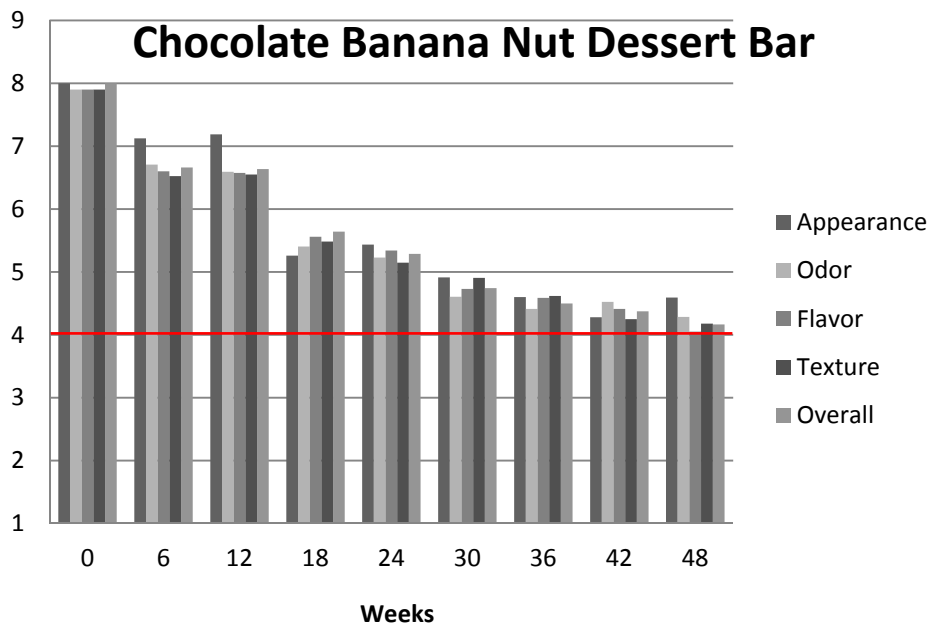

Figure 152. Changes in the quality attributes of Chocolate Banana Nut Dessert Bar stored at 100°F

The powdery outside appearance of the Chocolate Banana Nut Dessert Bar changed into a glossy look over time at 100°F and the chocolate chips merged into the background. The banana flavor faded and some panelists reported sour/bad milk like/rancid flavor in samples

stored for more than 36 weeks. The melt-down characteristic of the fresh product changed to a more crumbly texture. At 100°F these changes had not occurred to the extent that the product received scores below 4.0 on average. This product was kept the longest at this temperature and when it was finally removed it was because of the average scores not changing much over the course of the last 12 weeks of storage rather than any attribute reaching an average quality rating below 4.0.

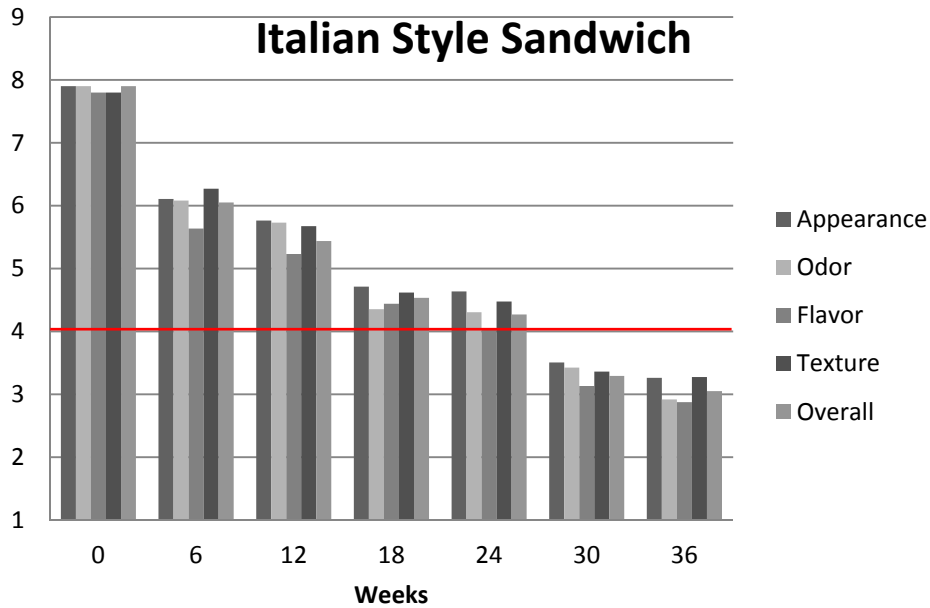

Figure 153. Changes in the quality attributes of Italian Style Sandwich stored at 100°F

The meat filling in the Italian Style Sandwich got darker and drier over time at 100°F. The flavorful spiciness of the fresh sample turned into a pungent, spicy-hot characteristic. The panelists used the word “stale” to describe both the odor and the flavor of the samples at 36 weeks of storage at 100°F.

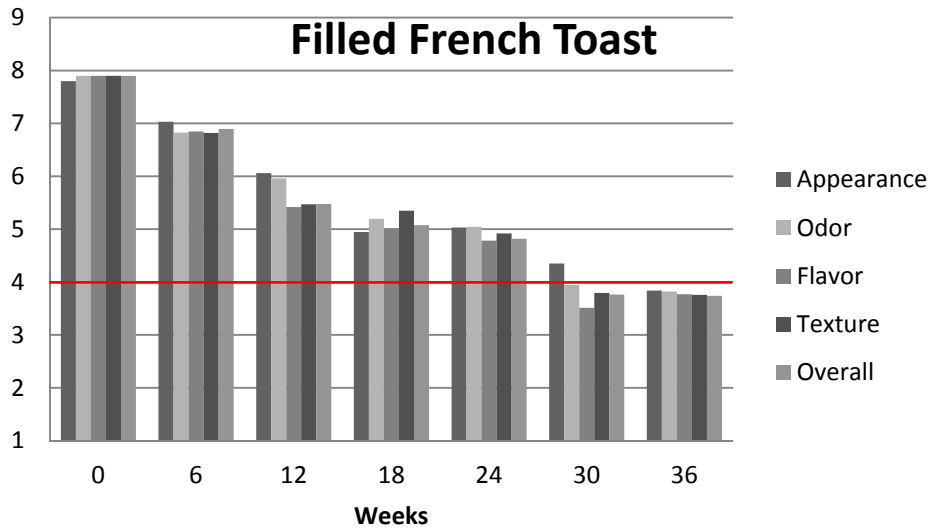

Figure 154. Changes in the quality attributes of Filled French Toast stored at 100°F

Both the bread and the filling of the Filled French Toast got darker over time at 100°F. The filling changed from a jelly consistency to a gel-like thickness, which was described as “gooey” by the panelists. The cinnamon and maple flavors of the fresh product were lost upon storage.

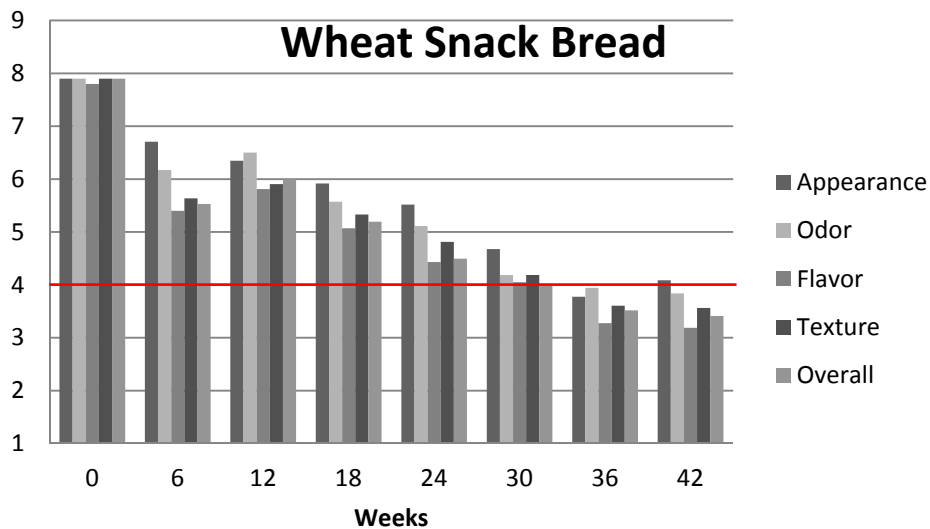

Figure 155. Changes in the quality attributes of Wheat Snack Bread stored at 100°F

Wheat Snack Bread was one of the products that were kept at 100°F for 42 weeks (one sampling period longer than most products) to make sure the mean quality scores were below 4.0 for two time points in a row. The product got darker and developed a stale odor. Panelists reported a bitter taste/aftertaste at 36 and 42 weeks of storage at 100°F.

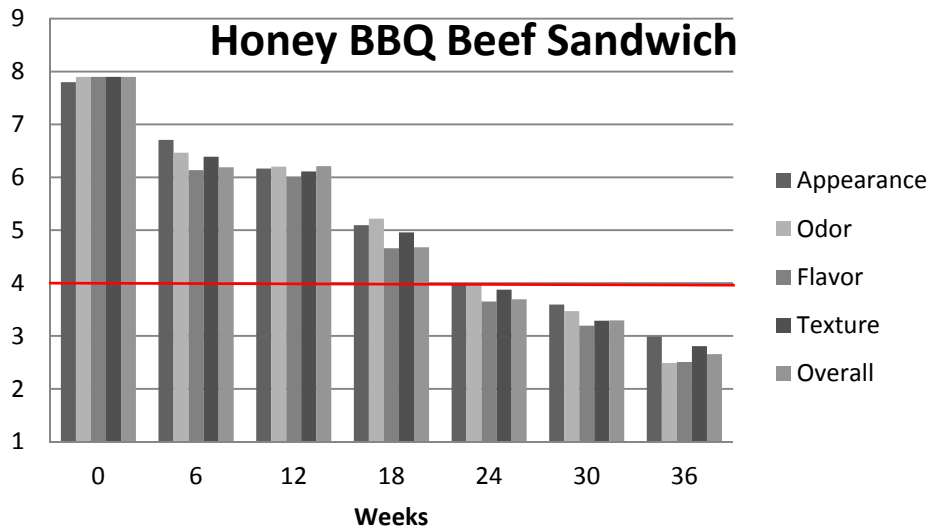

Figure 156. Changes in the quality attributes of Honey Barbecued Beef Sandwich stored at 100°F

Honey Barbecued Beef Sandwich was the first product to have mean quality scores below 4.0 at 100°F. The barbecue flavor changed into a tomato paste-like flavor over time. Panelists reported stale, “bad meat” and various off-flavors in the product stored for 36 weeks at this temperature.

3.3.3 120°F Storage

Nine FSR products (Filled French Toast, Italian Style Sandwich, Honey Barbecued Beef Sandwich, Bacon Cheddar Sandwich, Beef Snack BBQ, Zapplesauce, Chocolate Banana Nut Dessert Bar, Wheat Snack Bread, Tortilla) were sampled from the 120°F storage temperature every other week. Total storage time was 10 weeks for all products. The mean quality scores were calculated and are summarized in Figures 157-165.

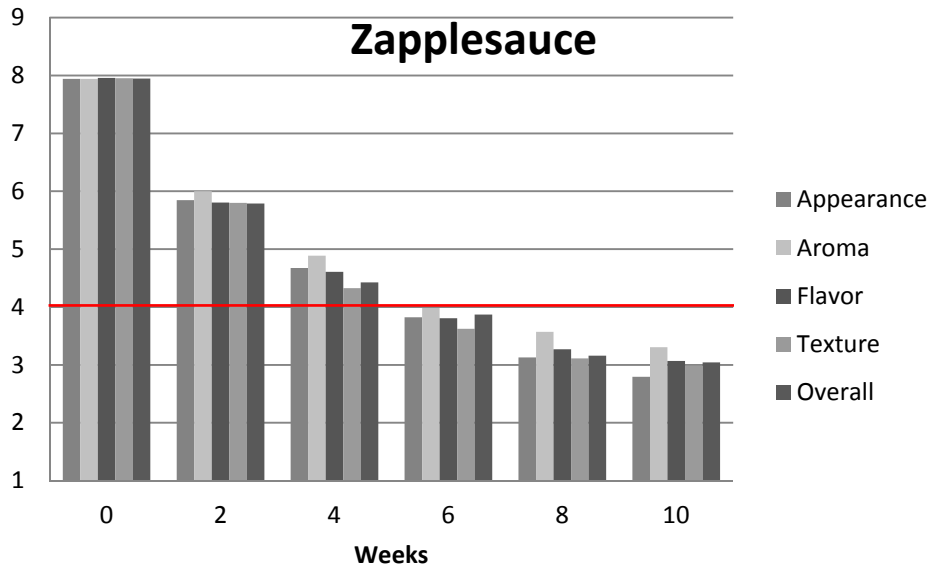

Figure 157. Changes in the quality attributes of Zapplesauce stored at 120°F

The quality changes in Zapplesauce at 120°F were the same as at 100°F. Namely, the product got darker and thinner with time and a stale, cardboardy aroma replaced the fresh apple aroma. These changes made the product unacceptable at 6 weeks.

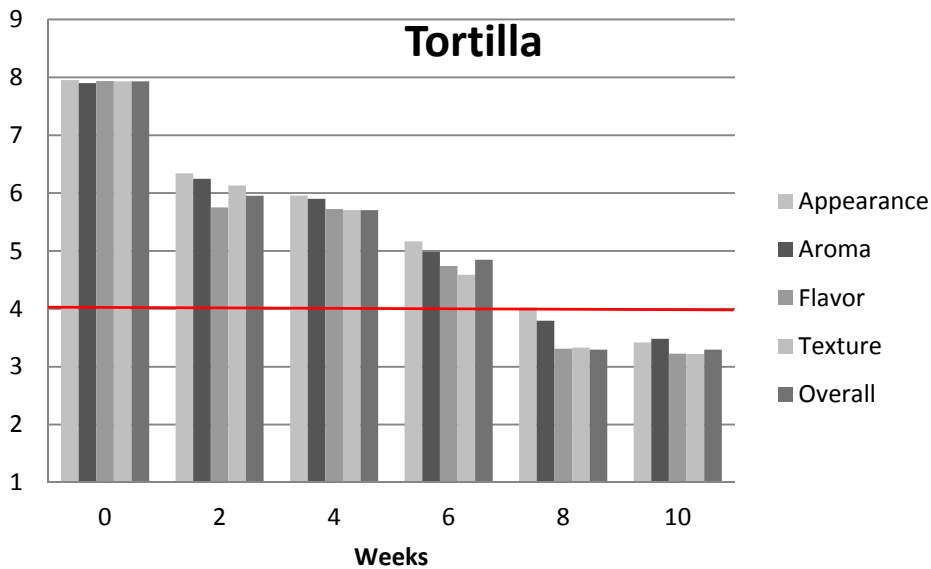

Figure 158. Changes in the quality attributes of Tortilla stored at 120°F

At around 8 weeks of storage at 120°F, Tortilla was unacceptable based on loss in pliability and bitter aftertaste. Average quality scores for appearance, odor, flavor, texture and overall are shown in Figure 158.

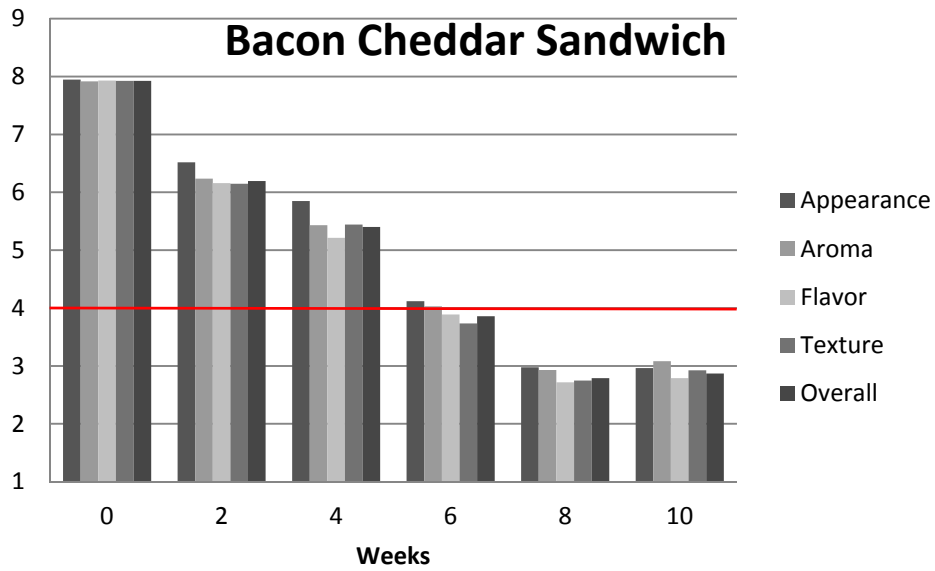

Figure 159. Changes in the quality attributes of Bacon Cheddar Sandwich stored at 120°F

Panelists reported crumbly brown bacon in a sandwich that had cheesy sourness or rancid flavor for Bacon Cheddar Sandwich after 8 weeks of storage at 120°F (Figure 159).

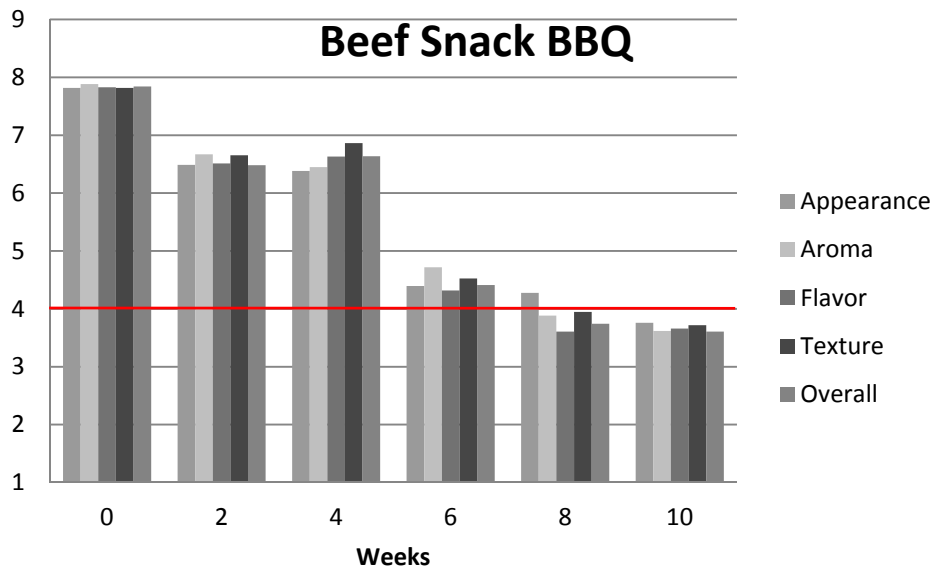

Figure 160. Changes in the quality attributes of Beef Snack BBQ stored at 120°F

Beef Snack BBQ was unacceptable after 8 weeks at 120°F due to the presence of off-flavors (Figure 160).

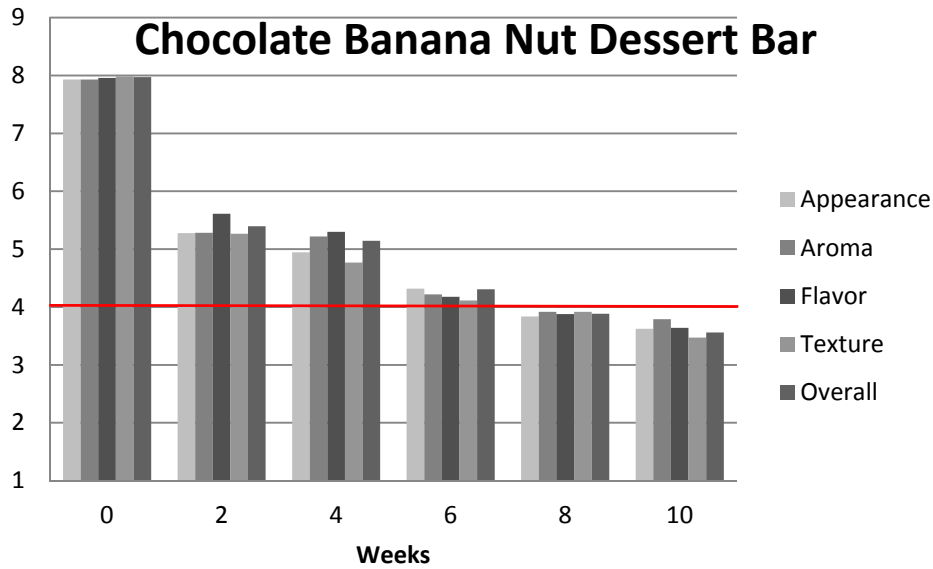

Figure 161. Changes in the quality attributes of Chocolate Banana Nut Dessert Bar stored at 120°F

All attributes of the Chocolate Banana Nut Dessert Bar were rated below 4.0 on average after 8 weeks of storage at 120°F. Glossy surface, lack of banana flavor and formation of some off-flavors as well as crumbly texture were reported in the stored product.

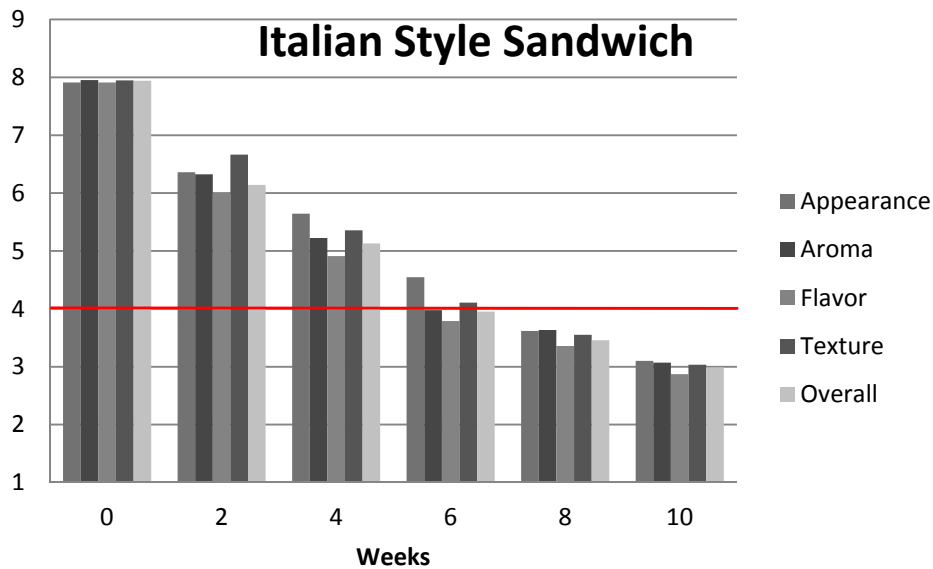

Figure 162. Changes in the quality attributes of Italian Style Sandwich stored at 120°F

The average quality score for the flavor of the Italian Style Sandwich dropped to below 4.0 after 6 weeks of storage at 120°F. This preceded deterioration of any other attribute. The spicy hot characteristic that develops in the product upon storage was easily perceivable by the panelists.

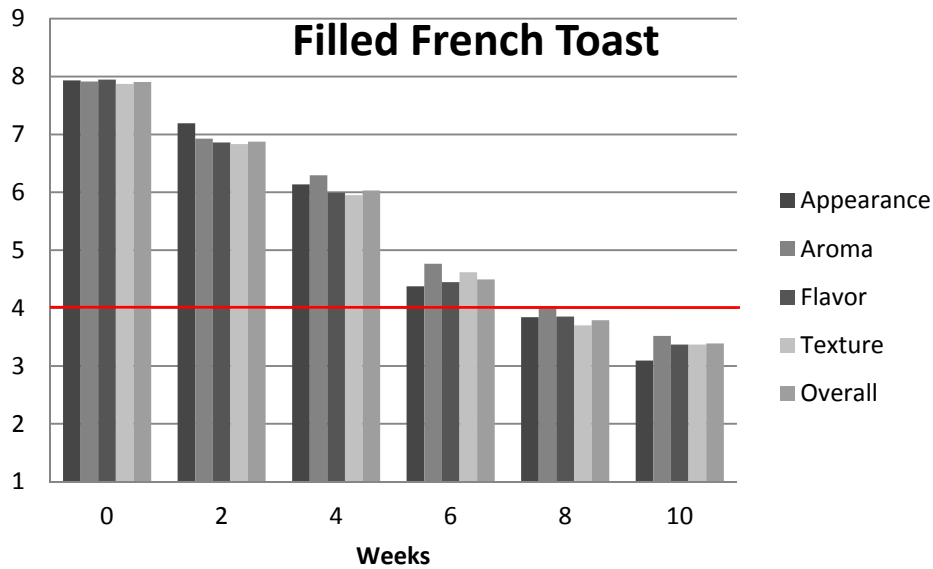

Figure 163. Changes in the quality attributes of Filled French Toast stored at 120°F

Filled French Toast was unacceptable after the 8th week of storage at 120°F (Figure 163). Both the bread and the filling got darker over time. The filling changed from a jelly consistency to a gel-like thickness. The cinnamon and maple flavor of the fresh product were diminished upon storage.

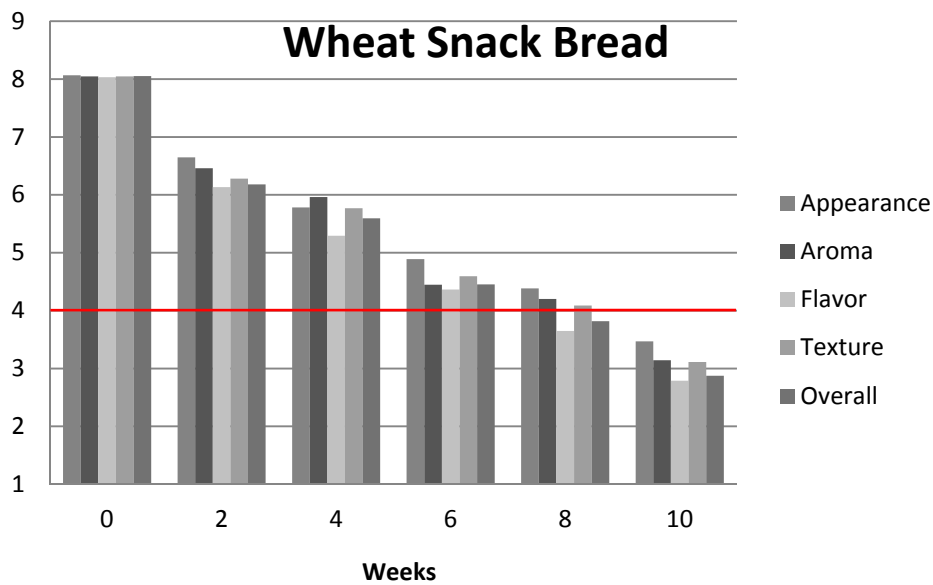

Figure 164. Changes in the quality attributes of Wheat Snack Bread stored at 120°F

Wheat Snack Bread was rejected for its bitter aftertaste at 8 weeks of storage at 120°F (Figure 164). Quality scores for all attributes dropped below 4.0 after 10 weeks of storage.

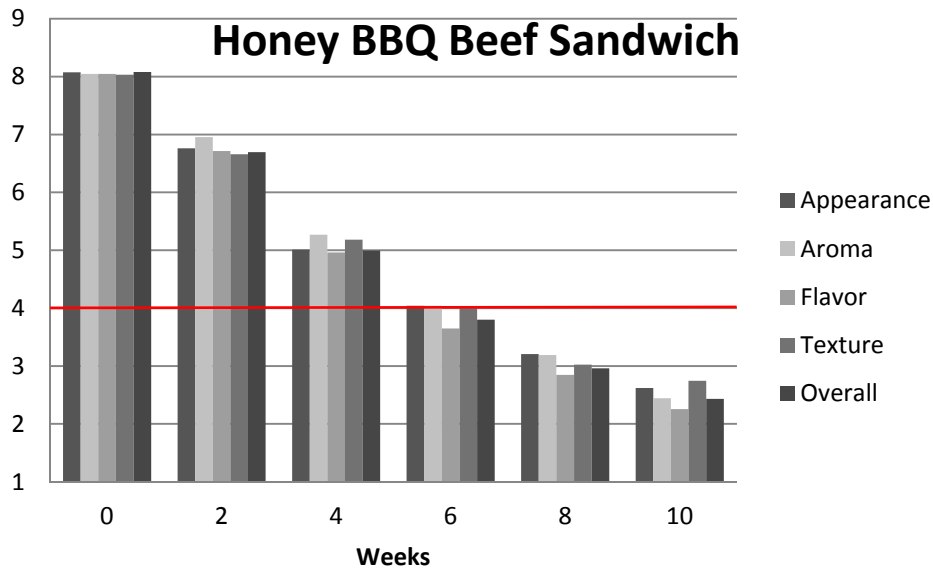

Figure 165. Changes in the quality attributes of Honey Barbecued Beef Sandwich stored at 120°F

The flavor and overall quality of Honey Barbecued Beef Sandwich averaged below 4.0 after 6 weeks of storage at 120°F. Panelists reported stale, rancid and various off-flavors in the product stored for 8 weeks at this temperature.

3.3.4 140°F Storage

Nine FSR products (Filled French Toast, Italian Style Sandwich, Honey Barbecued Beef Sandwich, Bacon Cheddar Sandwich, Beef Snack BBQ, Zapplesauce, Chocolate Banana Nut Dessert Bar, Wheat Snack Bread, Tortilla) were sampled from the 140°F storage temperature every week. Sampling was also done midweek after the 2-week and 3-week time periods. However, it was observed that the additional time points did not change the trend line and they were not included in the results. Total storage time was 5 weeks for all products. The mean quality scores were calculated and are summarized in Figure 166-174.

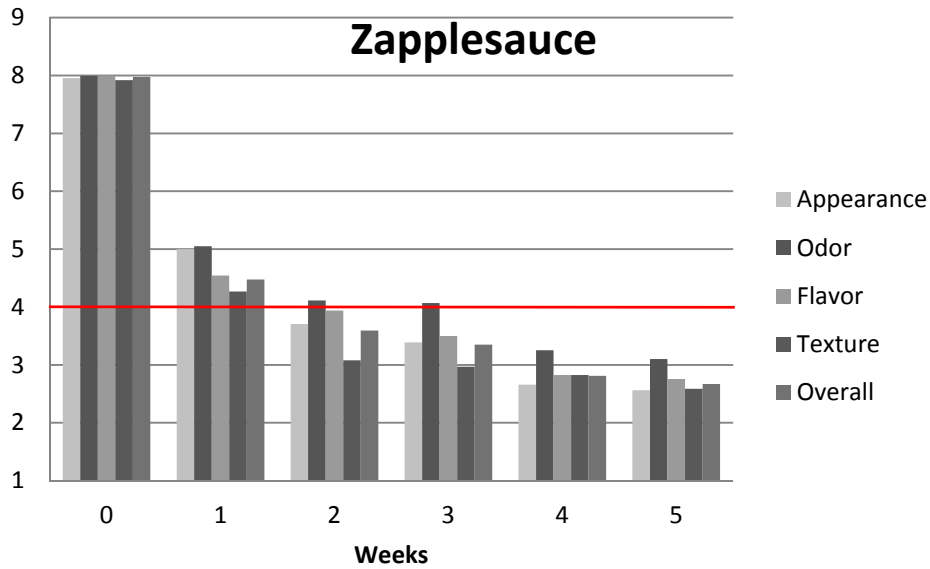

Figure 166. Changes in the quality attributes of Zapplesauce stored at 140°F

The changes in color, consistency and flavor of the Zapplesauce towards a dark, runny and stale tasting product made it unacceptable after as little as 2 weeks of storage at 140°F. With additional weeks of storage, panelists reported burnt color and flavor as well as liquid-like consistency.

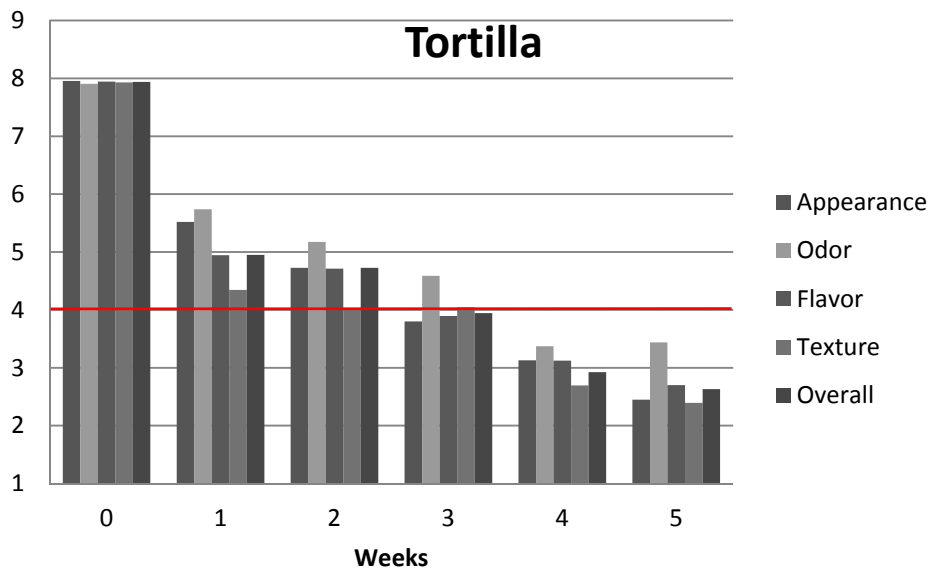

Figure 167. Changes in the quality attributes of Tortilla stored at 140°F

Tortilla started cracking and breaking as early as 2 weeks at 140°F. By the 3rd week, the decline in flavor, appearance and overall quality caught up with that in texture. At 5 weeks panelists reported tortillas stuck together, were darker yellow in color, and had a stale and bitter flavor.

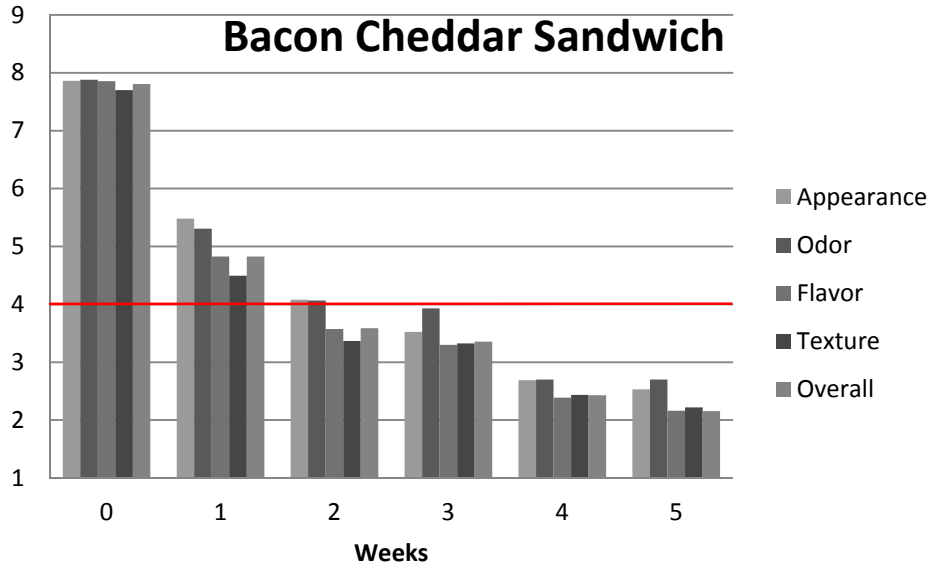

Figure 168. Changes in the quality attributes of Bacon Cheddar Sandwich stored at 140°F

The deterioration of Bacon Cheddar Sandwich at 140°F was rapid and the product became unacceptable after 2 weeks of storage due mainly to off-flavors and crumbly bacon and bread.

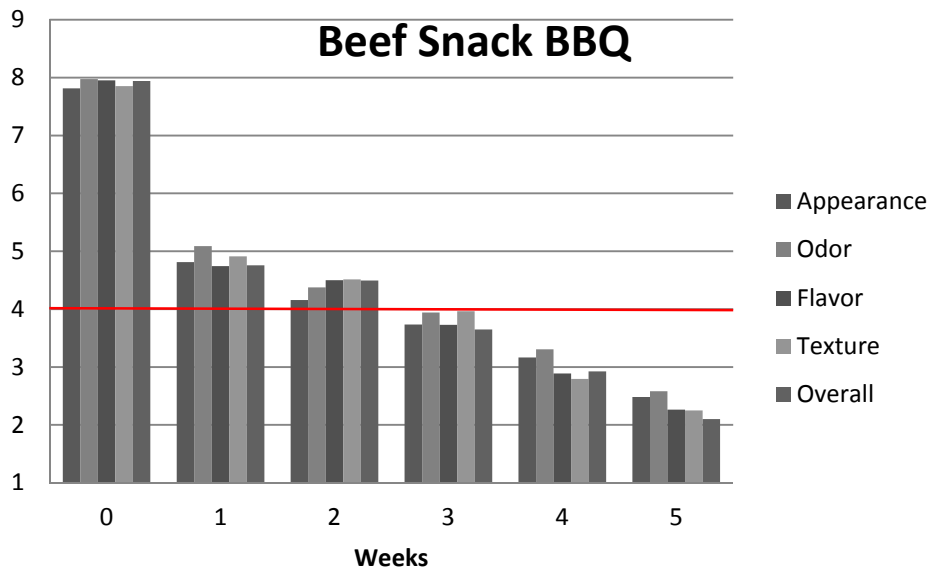

Figure 169. Changes in the quality attributes of Beef Snack BBQ stored at 140°F

After 3 weeks of storage at 140°F, BBQ flavored Beef Snack had a dark and oily appearance and no BBQ flavor left. Panelists reported burnt flavor and some described “pockets of brown goo” in the product at 3 and 4 weeks. At 5 weeks a number of panelists commented on how hard it was to bite into or chew this sample.

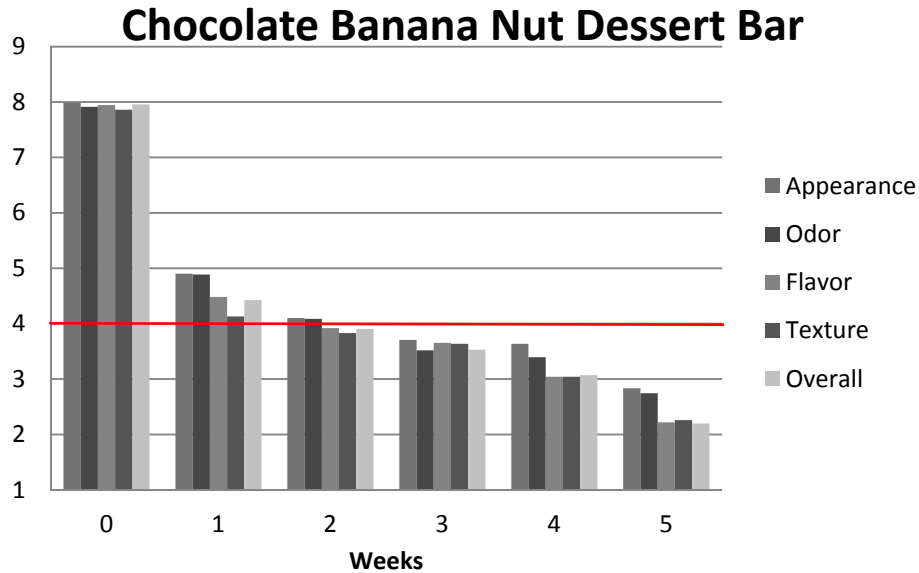

Figure 170. Changes in the quality attributes of Chocolate Banana Nut Dessert Bar stored at 140°F

Although the Chocolate Banana Nut Dessert Bar was one of the products to become unacceptable later during the storage at 120°F and although it never received average quality scores lower than 4.0 at 100°F, it deteriorated in flavor and texture properties as fast as some of the most sensitive products when stored at 140°F. “Rancid” and “sour character” were reported as early as the 2nd week of storage.

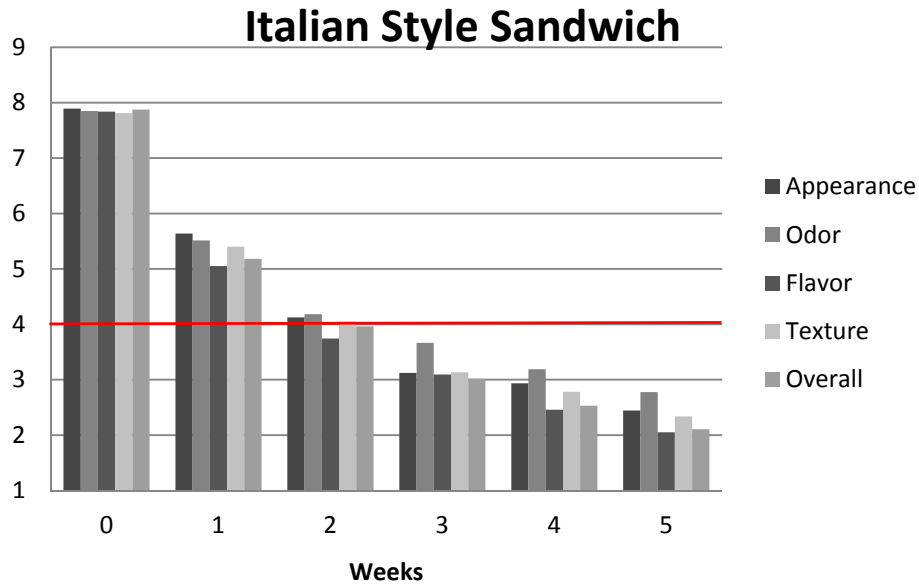

Figure 171. Changes in the quality attributes of Italian Style Sandwich stored at 140°F

The average quality score for the flavor of the Italian Style Sandwich dropped to below 4.0 after 2 weeks of storage at 140°F (Figure 171). Similar to the storage at 120°F, this preceded deterioration of any other attribute.

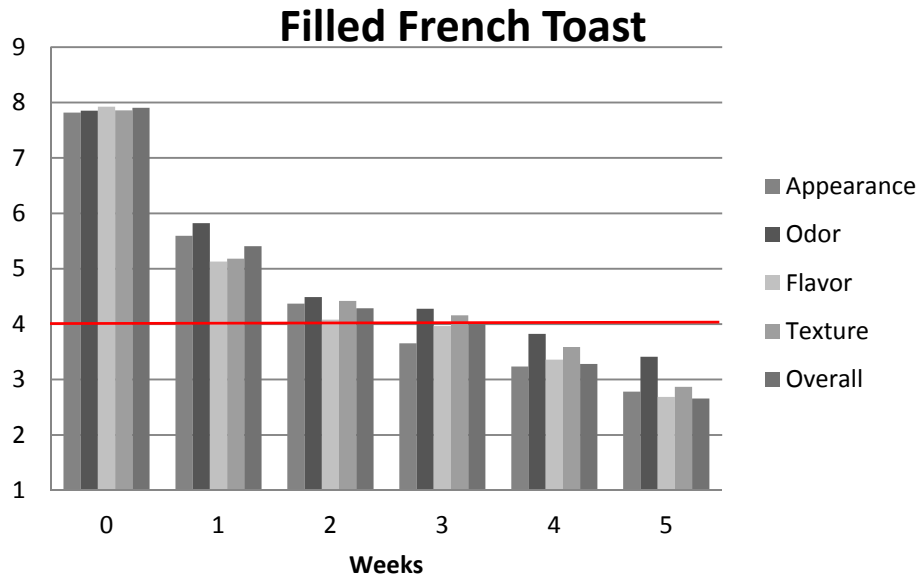

Figure 172. Changes in the quality attributes of Filled French Toast stored at 140°F

Filled French Toast was the product that survived the longest at 140°F. The product was unacceptable after 4 weeks of storage at this temperature (Figure 172).

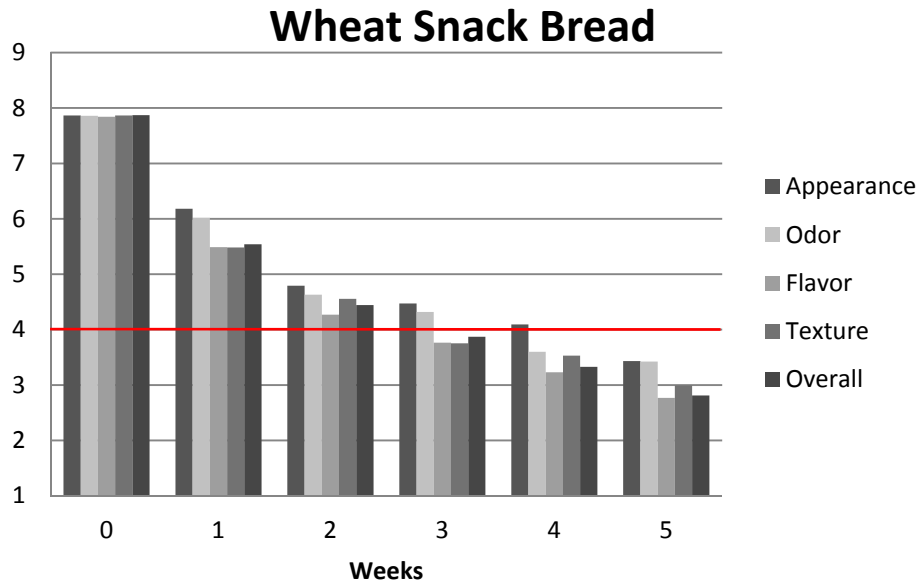

Figure 173. Changes in the quality attributes of Wheat Snack Bread stored at 140°F

Wheat Snack Bread stored at 140°F for 3 weeks became unacceptable (Figure 173) due to “very dry” texture and bitter aftertaste. “Stale” and “like old grain” smell were reported by panelists at 4 weeks.

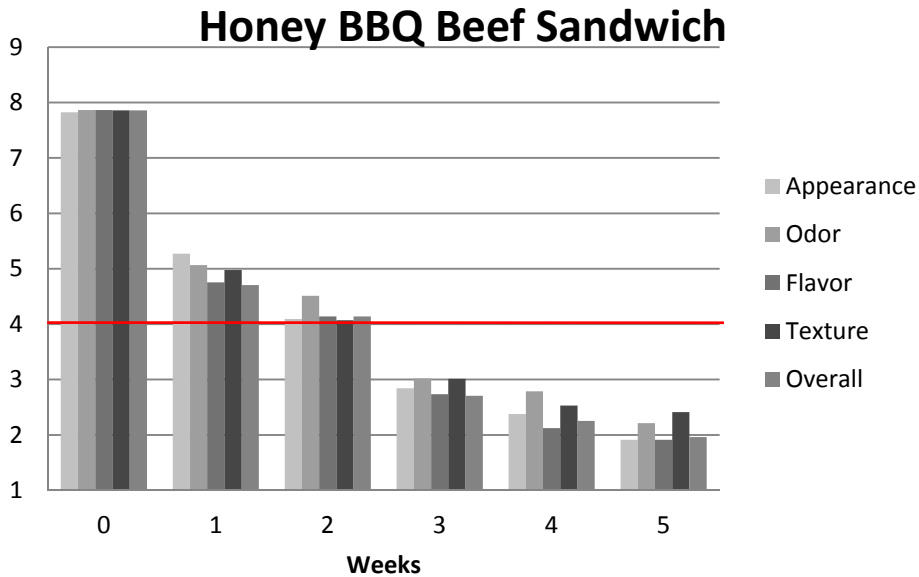

Figure 174. Changes in the quality attributes of Honey Barbecued Beef Sandwich stored at 140°F

Honey Barbecued Beef Sandwich was unacceptable due to changes very similar to those reported for the same product stored at 120°F. All quality scores dropped below the cut-off point of 4.0 at the end of 3 weeks at this temperature.

3.4 Summary

The results of the sensory quality evaluations were summarized in terms of number of weeks to product deterioration at each storage temperature (Table 18). Deterioration was defined by two successive mean quality scores below 4.0 for any attribute (appearance, odor, flavor, texture, overall). For most of the cases, the overall quality rating adequately described deterioration because the panelists would reflect any unacceptable attribute rating into the overall quality score. Italian Style Sandwich was the only product that received average flavor ratings falling in the rejection area without the overall quality score averaging below 4.0 (both at 120°F and 140°F). This may be explained by the spicy hot characteristic of the abused Italian Style Sandwich that is easily perceived by tasters.

Table 18. Weeks of storage before the mean overall quality score drops below 4.0

Products	80°F Every 16 weeks *	100°F Every 6 weeks	120°F Every 2 weeks	140°F Every week
Zapplesauce	5.5	30	6	2
Tortilla	6.2	36	8	3
Bacon Cheddar Sandwich	6.1	30	6	2
Beef Snack	5.7	30	8	3
Chocolate Banana Nut Dessert Bar	7.2	4.2 **	8	2
Italian Style Sandwich	6.0	30	6 (flavor only) ***	2 (flavor only) ***
Filled French Toast	5.6	30	8	4
Wheat Snack Bread	6.5	36	8	3
Honey BBQ Beef Sandwich	5.1	24	6	3

* There are additional samples in storage at 80°F that we will continue to evaluate through the end of 2011 as part of the Phase II project. The values reported here are the mean overall quality scores at 64 weeks.

**This is the mean overall quality score at 48 weeks. The previous mean quality scores were 4.7, 4.5 and 4.4 at 30, 36 and 42 weeks, respectively.

***The mean overall quality score dropped below 4.0 after 8 weeks of storage at 120°F and after 3 weeks of storage at 140°F.

Pearson correlation coefficients between the sensory quality attributes from Objective 2b and the physical and compositional measurements from Objective 2a of this project were calculated. Instrumental lightness measurement of all samples (except beef snack BBQ) correlated significantly with appearance quality as determined by the trained panel. Instrumental evaluation of texture of Zapplesauce, tortilla, bacon cheddar sandwich, beef snack, dessert bar and filled French toast as described in Section 2.2 of this report correlated significantly with texture quality scores from the sensory panel. Among other significant correlations are those for sucrose, glucose and fructose concentrations with flavor and overall quality of Zapplesauce and filled French toast, and the correlations of peroxide value of bacon cheddar sandwich with its flavor and overall quality.

4 Shelf Life Model Construction from Taste Panel Data⁴

4.1 Introduction

There are multiple approaches to shelf life modeling with perishable products the discussion of which is beyond the scope of this section of the report. Instead, in this section we will concentrate on how we constructed parametric models to estimate the drop in the quality index of different FSR products such as bacon cheddar sandwich and Zapplesauce, from an engineering point of view.

Based on the quality models used in this project (more information on this can be found in the later chapters of this report) each FSR item has five quality factors associated with them: appearance, flavor, odor, texture and overall quality. Each quality factor has a quality index (QI), which ranges between 9.0 and 1.0 where 9.0 indicates the highest (initial) quality and 4.0 indicates the lowest acceptable quality. In this regard, the basic idea is to calculate the current QI of the product for a specific quality factor based on the previous QI and the drop in the QI after a specific period of time at a specific temperature. The following equation summarizes this relation:

$$Q_{I_{current}} = Q_{I_{previous}} - f(Q_{I_{previous}}, t, T) \quad (10)$$

where $Q_{I_{current}}$ and $Q_{I_{previous}}$ indicates the current and previous QI values after a specific period of time, t , at an average temperature of T . As shown in the equation, the drop in the QI is a function of the previous QI, time and temperature. Hence, the problem of constructing a shelf life model with this approach can be reduced to finding where the current QI drops below 4.0, the acceptable QI threshold.

In order to find the current QI, one needs to find the function that calculates the drop in QI based on previous QI, time and temperature. This function will not only be different for each FSR item, but will also be different for each quality value such as flavor, texture, etc. Hence, to decide whether an FSR package is still usable or not, multiple quality models should be run on each item and quality factor to see which ones, if any, fall below the acceptable QI threshold of 4.0. In order to find the function for each item/quality factor pair, multiple taste panels have been conducted throughout the life of the project to obtain experimental data points on which the model can be built via interpolation and curve fitting. Four temperature points (80°F, 100°F, 120°F and 140°F) were used, and for each temperature different taste panel sampling periods were chosen, such as 6 weeks for 80 and 100°F, 2 weeks for 120°F, and 1 or 0.5 weeks for 140°F.

⁴ Prepared by: Ismail Uysal, Ph.D., University of South Florida Polytechnic, Lakeland, FL

4.2 Quality Index Determination From Taste Panel Results

Let's start with an example, Zapplesauce at 120°F temperature, for which the typical experimental results of a taste panel look like what is presented in Table 19.

Table 19. Example of Zapplesauce Taste Panel at 120°F

Weeks	Appearance	Aroma	Flavor	Texture	Overall
0	7.9	7.9	8.0	8.0	7.9
2	5.8	6.0	5.8	5.8	5.8
4	4.7	4.9	4.6	4.3	4.4
6	3.8	4.0	3.8	3.6	3.9
8	3.1	3.6	3.3	3.1	3.2
10	2.8	3.3	3.1	3.0	3.0

Please note that these results are averaged across people who participated in the taste panel. As shown in the table, at the end of week 6, appearance, flavor, texture and the overall quality of Zapplesauce all fell below 4.0 QI, indicating that the product was no longer acceptable for use. Even though the drop in QI can be deduced from this table, the sampling period is too long to be used directly in the shelf life model. For this application, based on a typical 2-year shelf life at normal room temperatures, the sampling rate of RFID tags will be set at 12 hours for an optimal trade-off between accuracy, memory capacity, and battery life. Hence, each RFID tag will be sampling the temperature twice per day as opposed to the sampling rate of 2 weeks in this taste panel. Hence, the first interpolation will take place on the axis of time and QI values, as seen in Figure 175.

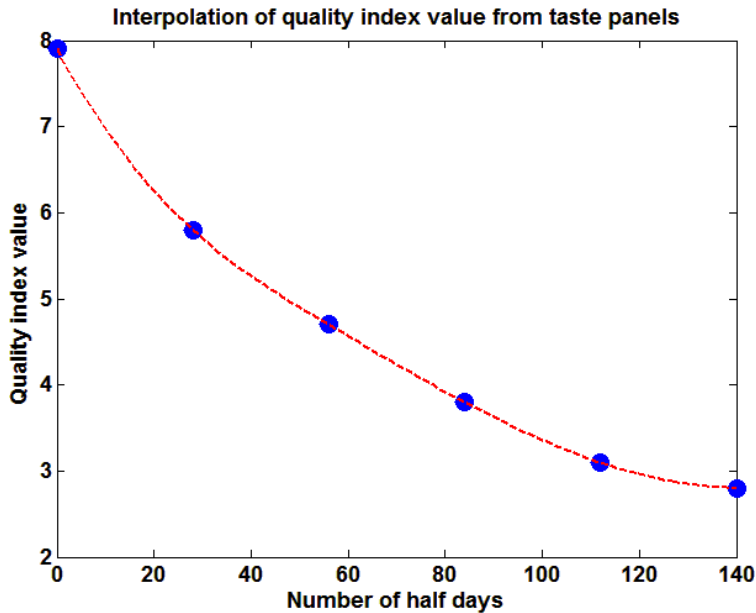

Figure 175. The interpolation of quality index value for the appearance of Zapplesauce at 120°F

Figure 175 shows the interpolation of discrete taste panel data (every 2 weeks) to a higher sampling rate of every half day (based on the RFID sampling rate). In order to accomplish this interpolation, we have used Matlab mathematical software with *spline* interpolation. The discussion of *spline* interpolation is beyond the scope of this report; however it is important to mention that it is a form of interpolation where the interpolant is a special type of piecewise polynomial called a *spline*. It is superior to more commonly used polynomial interpolation, especially for this problem, since the interpolation error can be made much smaller thanks to piecewise interpolation between widely separated experimental data points.

From Figure 175, the shelf life modeling algorithm can easily tell how QI changes with time at a specific temperature (120°F in this case) from an initial value of 7.9. However, as stated in the equation for the model, we are more interested in how the drop in QI is affected by the previous quality index value at that temperature. Since we have time difference as a constant (12 hours) we can deduce this information from Figure 175 by finding for each possible QI value how much the drop will be after 12 hours at 120°F. In order to do this, we define a vector of QI values with a resolution of 0.1 from 4.0 to 9.0 as follows:

$$QI_x = [4.0 \ 4.1 \ 4.2 \ \dots \ 9.0] \tag{11}$$

For each entry in the QI_x vector, we find the corresponding “closest” entry in the QI vector as shown in Fig. 4.2.1. For example, for a QI_x of 5.4, the closest entry in the interpolated QI vector is $QI(39) = 5.3854$. Next step is to find $QI(40)$ value to determine what the next QI value will be after exactly 12 hours so we can calculate the associated drop. It turns out $QI(40) = 5.3443$. The difference between $QI(40)$ and $QI(39)$ is: $QI(40) - QI(39) = 0.0411$, which means that, at

T=120°F, and t=12 hours, the drop in QI value for an initial QI value of 5.4 will be equal to 0.0411 (Figure 176).

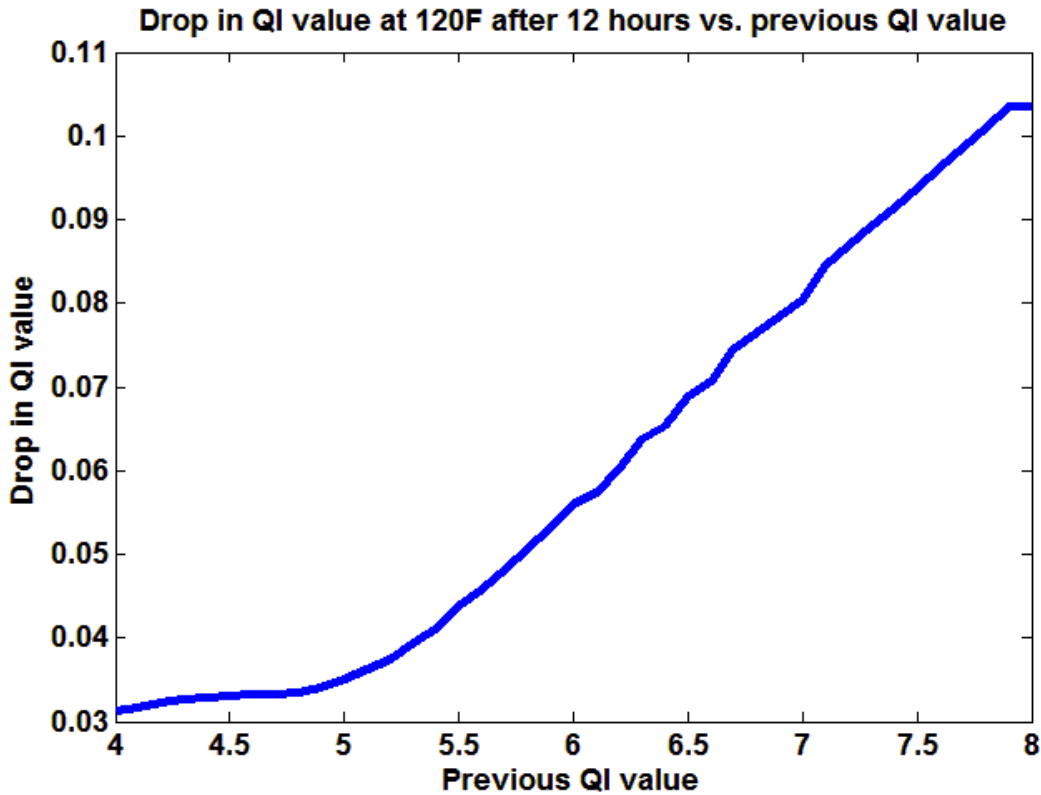

Figure 176. The plot that shows how much QI will drop depending on previous QI value, temperature and time

Figure 176 shows the relation between the drop in QI value with the previous QI value at a fixed temperature after a fixed period of time. This figure constructs the base of the shelf life algorithm.

Please note that Figure 176 is only for a specific quality factor (appearance) of a specific product (Zapplesauce) in FSR. Hence, curves like this need to be constructed for each product and quality factor pair. However, we know that even though the time steps will always be a constant (12 hour sampling rate), the temperatures will be different for each trial. The next step is to generate the same figures at the other treatment temperatures. Hence, at the end, for each previous QI value ranging from 4.0 to 9.0, we will have a “drop in QI value within 12 hours” for each of the treatment temperatures. However, the actual temperature recorded by the tag can be anything between (or beyond) these temperatures, which requires a 2nd round of interpolation over temperatures. Contrary to interpolation over QI values, this poses a problem since the limits of temperature are not as well defined as the limits of QI values.

For example, Figure 177 shows the results of spline interpolation to estimate the drop in quality value, given a previous QI value, with temperature.

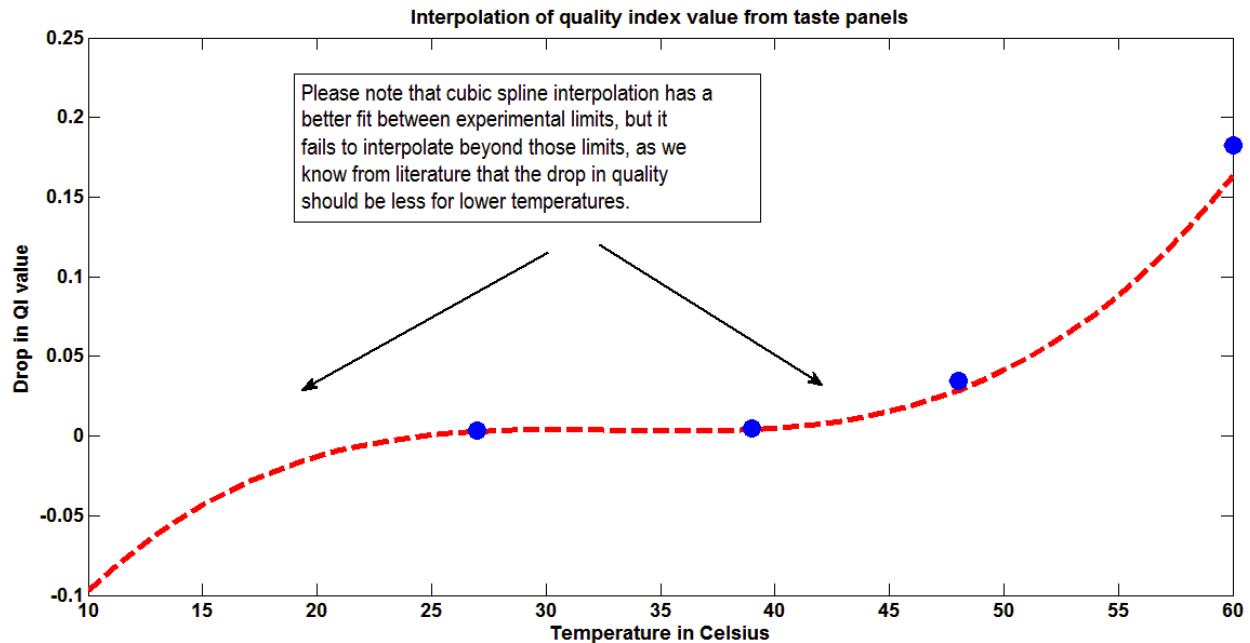

Figure 177. The spline interpolation for the drop in QI value vs. temperature relation

Please note that the interpolation, though pretty accurate within the four experimental data points, fails beyond these limits. We know that the quality of a food product is better preserved at lower temperatures. However, spline interpolation in this case tells us that the quality of the product “increases” with time at low temperatures, which is physically impossible.

Another way to solve this problem is to assume an exponential relationship between the drop in quality value and environmental temperature (as indicated by previous researchers such as the Arrhenius equation). If we assume there is an exponential relation between temperature and quality value drop, then there should be a linear relation between temperature and the logarithmic value of quality drop, which can be solved using linear interpolation. Figure 178 shows the results of such an interpolation technique.

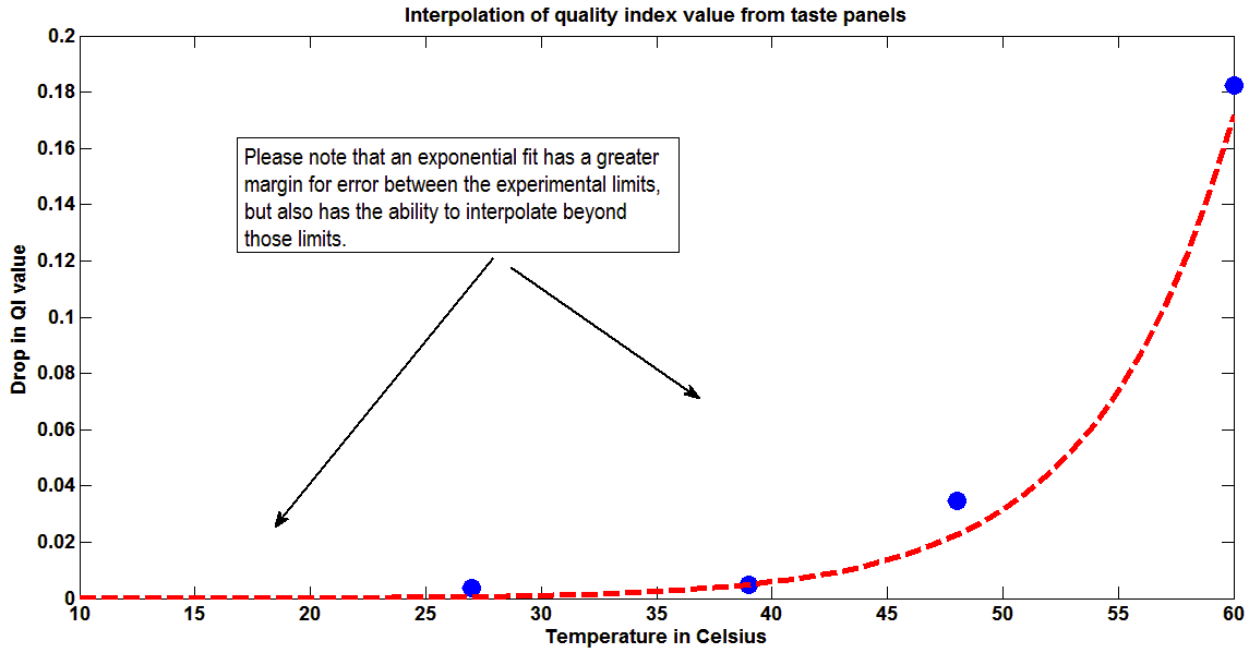

Figure 178. The logarithmic-linear interpolation for the drop in QI vs. temperature relation

As shown in the above figure, even though such interpolation is not as accurate as spline within the experimental temperature points, it is more effective beyond those limits and can model real life temperatures better.

Hence, after this last step, for each previous QI, an equation can be constructed as in Figure 178 that defines the drop in QI vs. increasing temperature. However, in order to make the algorithm run faster on a handheld reader, this equation can be calculated at pre-defined temperature points (such as every 1°F) and a QI drop value can be found for each (previous QI, temperature) pair, which results in the so-called 2x2 quality matrices for each product-quality factor pair.

These matrices now define the function f , in the first equation for the model.

$$Q_{I_{current}} = Q_{I_{previous}} - f(Q_{I_{previous}}, t, T) \quad (12)$$

Given the previous QI, time (which is always constant at 12 hours), and average temperature within that time (mean of last and previous temperature recordings), the quality matrix will return the drop in QI, which can then be used to calculate the current QI. Figure 179 shows how the drop in QI value changes with temperature for different previous QI values.

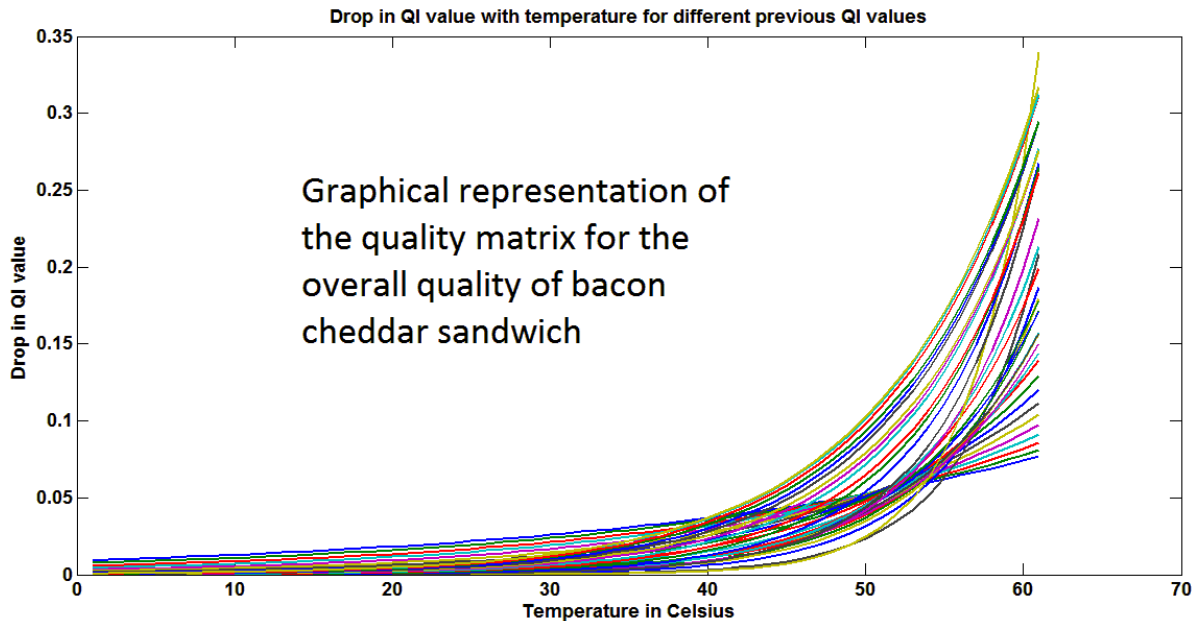

Figure 179. Graphical representation of the quality matrix for one of the product-quality pairs

Figure 179 shows each function (in a different color) relating temperature to a drop in quality value based on the previous QI in graphical format. Here, each colored line represents an initial QI between 4.0 and 9.0.

Having the quality matrices for each product-quality factor pair will allow the user to calculate the current QI for each pair depending on the temperature history by iteratively calculating QI starting with the initial value of 9.0. The point at which iterative calculation of QI drops below the threshold level of 4.0 defines the point at which the product’s shelf life has expired.

The operation of the shelf life algorithm, after constructing the model f , is summarized as a flow diagram in Figure 180. As can be observed from the flow diagram, the model runs on each product and each quality in a recursive manner. Hence, multiple quality curves for each of the product-quality pairs are calculated one by one and a decision is based on the overall assessment of estimated final qualities for each and every quality factor (appearance, odor, taste, etc.) for each product (Zapplesauce, bacon cheddar sandwich etc.). If one of the pairs has a QI value of less than 4, the product is declared expired.

If all the pairs have QI values of greater than 4, the algorithm runs in a similar recursive loop to estimate the remaining shelf life. In order to do that, the algorithm finds the quality-product pair that would first cross the threshold of 4, given the average temperature profile, and records the time it would require to reach that threshold, which provides the estimated shelf life of the product.

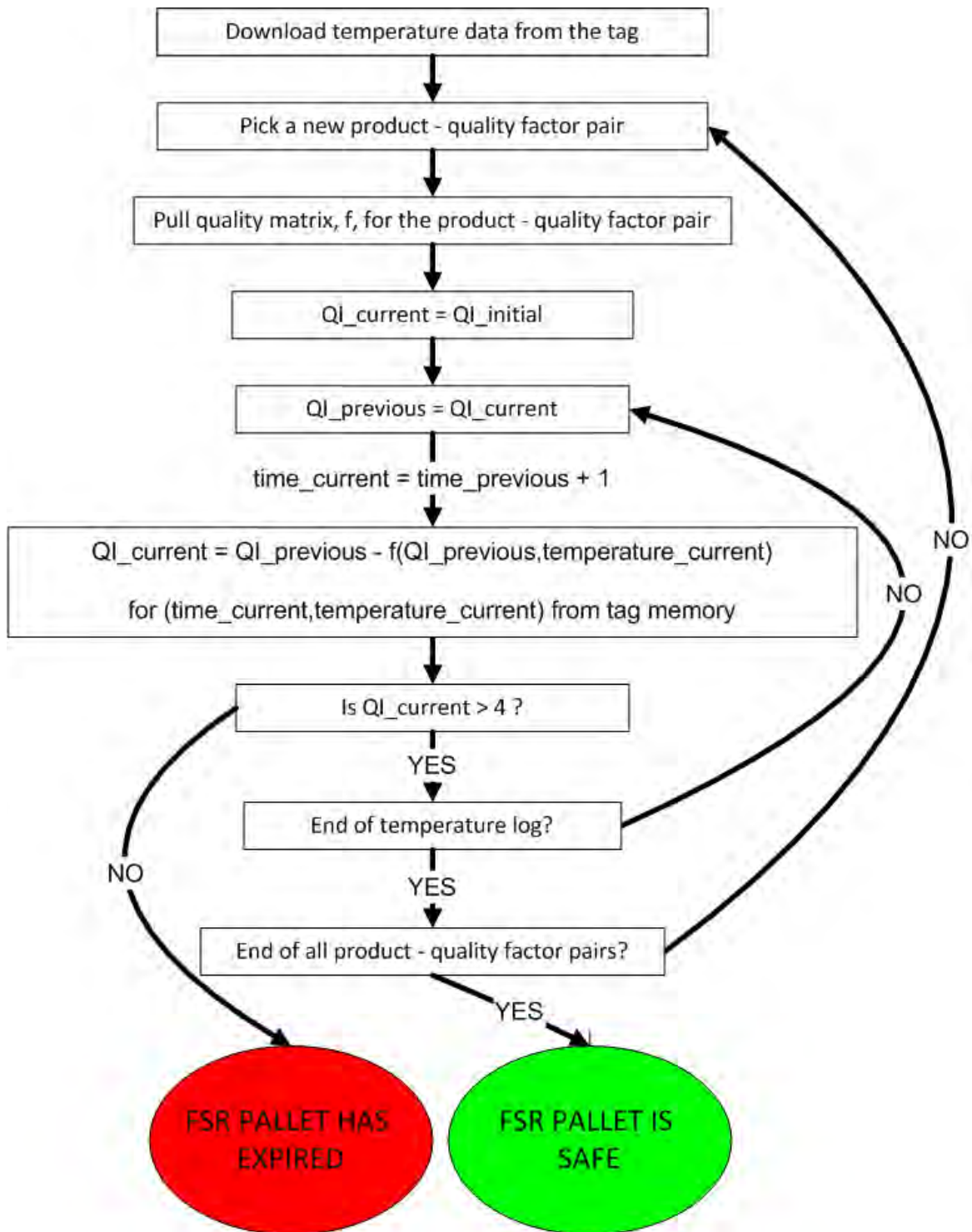

Figure 180. Complete flow diagram for the shelf life estimation algorithm

5 Final Budget

These are the Life-to-Date (10/01/08 – 12/31/10) cumulative budget figures by major budget category. The final figures, including detailed transaction history, have been included on the final public cost voucher and were submitted through WAWF on 15 March, 2011.

Please direct financial inquiries to Jonathan Evans @ jonevans@ufl.edu.

	<u>Life to Date Cumulative</u>
Major Cost Elements: 10/01/08 -12/31/10	
Salaries	\$ 880,167.56
Fringe Benefits	\$ 114,975.80
Materials & Supplies	\$ 73,504.42
Other Expenses	\$ 640,803.86
Travel	\$ 24,020.34
Equipment	<u>\$1,569,950.49</u>
Total Direct Costs:	\$3,303,422.47
Overhead @48.5 MTDC	<u>\$ 588,504.08</u>
Total Amount Claimed:	\$3,891,926.55
Total Contract Amount:	\$4,008,960.00
Residual:	\$ 117,033.45

5.1 Equipment Record

Table 20. Equipment Record

Description	Cost	Location
SENSOR, ELECTROCATALYTIC, ETH-1010	\$9,100.00	UF-HOS*
SPECTROPHOTOMETER, XS2 POWERWA, BIOTEK	\$13,977.99	UF-HOS
GAS CHROMATOGRAPH, 3800 VARIAN	\$19,524.00	UF-HOS
GAS CHROMATOGRAPH, VARIAN	\$28,978.00	UF-HOS
GAS CHROMATOGRAPH, MASS SPEC, AGILENT	\$67,055.20	UF-HOS
AGILENT GC-MS SETUP	\$13,138.82	UF-HOS
COMPUTER, DELL LATITUDE E6400	\$1,293.23	UF-FOS*
COMPUTER, DELL LATITUDE E4300 (10)	\$14,899.40	UF-FOS
CONTROL TEMP ROOMS (12), PROG, CONVIRON		UF-ABE* (3) & UF-HOS (9)
WITH VIBRATION TEST STAND, LANSMONT	\$1,061,109.71	UF-ABE
METER, WATER ACTIVITY, AQUALAB	\$7,730.09	USFP*
HPLC SYSTEM, HITACHI LCU	\$84,989.00	USFP
TEXTURE ANALYZER, TA.XT P 50	\$31,664.00	USFP
CHROMA METER, CR-410, MINOLTA	\$6,602.08	USFP
ANALYZER, REAL TIME SPECTRUM	\$31,927.00	USFP
GENERATOR, FUNCTION 4087 120MH	\$1,650	USFP
GENERATOR, RF SIGNAL AGILENT	\$6,237.23	USFP
FIXED READER, MOTOROLA XR450 (2)	\$6,873.32	USFP
COMPUTER, APPLE IMAC 24"	\$1,788.00	USFP
POWER SUPPLY, XTR33-25 XANTREX	\$1,422.42	USFP
READER, MOTOROLA MC9090 HANDHELD (3)	\$15,810	USFP
ANALYZER, VNA MASTER NETWORK	\$12,104.00	USFP
MODULE, 1.0 - 2.5GHZ 10W	\$2,356.91	USFP
MODULE, 1.0 - 1000MHZ 50W	\$4,591.91	USFP
UHF READER, INFRATAB RFID (3)	\$12,082.44	USFP
UHF READER, CAEN RFID (3)	\$24,082.44	USFP
COMPUTER, MOTOROLA WT4090 MOBI (2)	\$10,058.80	USFP
COMPUTER, APPLE MACBOOK AIR 13 (2)	\$3,398.00	USFP
GPS, SAVER 9X SHOCK & VIBRATIO	\$8,466.50	USFP
RFID READER, W/INTELLIFLEX DRV	\$11,900.00	USFP
RFID READER, W/IDENTEC DRIVER	\$13,200.00	USFP
SERVER, DELL POWEREDGE R900	\$30,900.00	USFP
SCANNER, GEC THERMOCOUPLE	\$11,040.00	USFP
Total	\$1,569,950.49	

*UF-HOS, UF-FOS and UF-ABE = University of Florida, Horticultural Sciences Department, Food Science & Human Nutrition Department, and Agricultural & Biological Engineering Department, respectively, Gainesville, FL; USFP = University of South Florida Polytechnic, Lakeland, FL.

6 Overall Conclusions

Using wireless temperature sensors, remote monitoring (RFID), algorithms, and diagnostics, it was demonstrated that FSR shelf life can be automatically calculated in real time using web-based computer models. A fully functional prototype RFID system was developed during this project as a result of extensive testing. Intellex tags were selected because they showed high accuracy in both temperature accuracy and environmental simulation tests, had a longer communication range than other tested tags, and are based on an advanced class 3 communication protocol, making them future-ready in terms of adaptability to other systems and RFID readers.

The quality and shelf-life of selected FSR menu items when exposed to extreme ambient temperatures was determined using measurements of the physical and compositional characteristics of the products and evaluation of the sensory quality. The results of these measurements and evaluations provided data for development of algorithms to iterate each quality factor for each FSR menu item with specific time increments. The algorithms were validated and calibrated, and software was developed for models to predict remaining shelf life from a handheld reader.

As a result of this project, the NSRDEC, Combat Feeding Directorate now has an RFID based portable solution to monitor and track the environmental temperature of FSR for accurate estimation of remaining shelf life prior to consumption.

This document reports research undertaken at the U.S. Army Natick Soldier Research, Development and Engineering Center, Natick, MA, and has been assigned No. NATICK/TR- 12/009 in a series of reports approved for publication.

This Page Intentionally Left Blank

Appendix A - Environmental Testing Results

80% Requirement Range Span Testing (Schedule A)

	MSE	STD	Corr.
Caen	2.63°F	2.12°F	0.998849
Infratab (not frozen)	0.40°F	0.85°F	0.99959
Intellex	0.56°F	0.94°F	0.999828

Extended Requirement Limit Testing (Schedule B)

	MSE	STD	Corr.
Caen	2.12°F	1.944°F	0.999688
Infratab (frozen)	2392.2°F	51.84°F	0.874171
Infratab (not frozen)	0.61°F	0.504°F	0.998352
Intellex	3.46°F	2.41°F	0.999516

Freezing Temperature Testing (Schedule C)

	MSE	STD	Corr. Coeff.
Caen	26.64°F	6.95°F	0.98581
Intellex	4.356°F	2.72°F	0.998551

Two-Point Swing Testing (Schedule D)

	MSE	STD	Corr. Coeff.
Caen	8.73°F	3.96°F	0.976594
Infratab	3.62°F	2.56°F	0.990501
Intellex	0.09°F	0.25°F	0.999904

Truck Mode Vibration with 104°F to 5°F Temperature Profile

	MSE(wall)	MSE(table)	STD(wall)	STD(table)	Corr. (wall)	Corr. (table)
Caen	1.53°F	1.75°F	1.62°F	1.78°F	0.998843	0.998497
Infratab (not frozen)	0.59°F	1.98°F	1.03°F	1.91°F	0.999123	0.997908
Intellex	0.49°F	0.94°F	0.63°F	0.90°F	0.999916	0.999742

Rail Mode Vibration with 104°F to 5°F Temperature Profile

	MSE	STD	Corr.
Caen	1.66°F	1.73°F	0.998553
Infratab (non frozen)	3.74°F	2.48°F	0.928471
Intellex	2.39°F	1.66°F	0.999278

Air Mode Vibration with 104°F to 5°F Temperature Profile

	MSE	STD	Corr.
Caen	2.00°F	1.84°F	0.998474
Infratab (non frozen)	0.83°F	1.24°F	0.999096
Intellex	0.76°F	0.90°F	0.999654

Truck Mode Vibration with 59°F to 118.4°F Temperature Profile

	MSE	STD	Corr.
Caen	0.18°F	0.54°F	0.999547
Infratab	1.51°F	0.85°F	0.999522
Intellex	0.07°F	0.24°F	0.999916

Rail Mode Vibration with 59°F to 118.4°F Temperature Profile

	MSE	STD	Corr.
Caen	0.18°F	0.57°F	0.99953
Infratab	1.46°F	0.72°F	0.999397
Intellex	0.02°F	0.18°F	0.999949

Air Mode Vibration with 59°F to 118.4°F Temperature Profile

	MSE	STD	Corr.
Caen	0.14°F	0.38°F	0.999615
Infratab	1.80°F	0.94°F	0.999208
Intellex	0.13°F	0.32°F	0.999867

Sine Mode Vibration Tests @ 118.4°F, 89.6°F, 59°F, 32°F, and 5°F

	118.4°F		89.6°F		59°F		32°F		5°F	
	MSE	STD	MSE	STD	MSE	STD	MSE	STD	MSE	STD
Caen	0.04°F	0.02°F	0.18°F	0.05°F	0.00°F	0.00°F	0.20°F	0.07°F	0.02°F	0.07°F
Infratab	16.22°F	1.03°F	1.03°F	0.16°F	11.07°F	0.85°F	1.62°F*	0.45°F*	NA	NA
Intellex	0.05°F	0.04°F	0.00°F	0.04°F	0.02°F	0.04°F	0.14°F	0.14°F	0.14°F	0.04°F

Appendix B - System Specification Sheets



Intellex TMT-8500

Temperature Monitoring Tag

- Temperature monitoring for perishable foods and pharmaceuticals
- Reliable reads/writes at 100m or without unpacking
- Onboard memory stores 3,600 temperature samples
- Two year battery life—based on typical use cases
- Based on ISO and EPCglobal standards

The Intellex TMT-8500 Temperature Monitoring Tag is an XC3 Technology™ RFID tag that combines high sensitivity temperature sensing functionality with ISO standards-based RFID wireless communications. This combined functionality provides market leading visibility, efficiency and improved ROI for perishable foods and pharmaceutical cold chain management by enabling solutions that leverage the benefits of RFID (including real time data access, long range reads, and autonomous data collection with no line of sight restriction) without impacting existing business processes.

The TMT-8500 is based on the ISO C3 (ISO 18000-6.1 C Chapter 11) and EPCglobal Gen 2 Class 1 protocols, with extended memory (60kbits) for data storage, and a microcontroller temperature sensing application. Support for the ISO and EPCglobal protocols enables the TMT-8500 to provide extended RFID capabilities including enhanced read/write sensitivity equating to read ranges in excess of 100 meters, superior battery power management and the full functionality and configurability of a microcontroller-based temperature sensing application. The TMT-8500 is configurable for both single use and multiple-use applications.

Product Features

RF Interface	ISO 18000-6.1 (Manoheater BAP), EPCglobal C1G2
Read Range	100 meters or more in free space in ISO Class 3 mode. Global read support (except for Japan)
Security	User Access, Block Memory Access, Air Interface and Tag Authentication security layers
Memory	Standard EPC tag ID memory plus 60 kbits of extended memory for Sensor, User and WayPoint Data – configurable by the end user. Up to 3,600 temperature samples that can be logged in the sensor memory
Sampling Interval	User configurable from one (1) minute to five (5) days
Start Sample Time	User configurable: selects a time offset delay to start data logging from initial button press or set a specific date and time to start data logging



Alarms	Four (4) configurable thresholds: Two user configurable high temperature and two low temperature alarms												
Logging Modes	Multiple data logging modes for increased storage capacity and increased monitoring time												
Temperature Range	The operating temperature measurement range is -30°C to +70°C (-22°F to +158°F)												
Temperature Accuracy	The maximum temperature measurement error variance is indicated in the table below												
	<table border="1"> <thead> <tr> <th>Temperature Range</th> <th>Allowable Variance</th> </tr> </thead> <tbody> <tr> <td>-22°F to 0°F (-30°C to -18°C)</td> <td>±2°F (±1.1°C)</td> </tr> <tr> <td>0°F to +122°F (-18°C to +50°C)</td> <td>±1°F (±0.5°C)</td> </tr> <tr> <td>+122°F to +158°F (+50°C to +70°C)</td> <td>±2°F (±1.1°C)</td> </tr> </tbody> </table>	Temperature Range	Allowable Variance	-22°F to 0°F (-30°C to -18°C)	±2°F (±1.1°C)	0°F to +122°F (-18°C to +50°C)	±1°F (±0.5°C)	+122°F to +158°F (+50°C to +70°C)	±2°F (±1.1°C)				
Temperature Range	Allowable Variance												
-22°F to 0°F (-30°C to -18°C)	±2°F (±1.1°C)												
0°F to +122°F (-18°C to +50°C)	±1°F (±0.5°C)												
+122°F to +158°F (+50°C to +70°C)	±2°F (±1.1°C)												
Temperature Resolution	0.1°C (1/10th degree) over full temperature range												
Compliance	NIST, FAA												
Clock Accuracy	Real-time clock and timer accuracy of ±1 minute/month												
Battery/Battery Life	3V Lithium battery, UL rated; meets UN Part III, sub-section 38.3 test criteria. Two year battery life — based on typical use cases												
SLPM	Shelf Life Prediction Modeling (SLPM) capability at multiple levels of sophistication are supported, from generic and custom on-tag calculations to sophisticated analytics using software APIs												
Environmental Specifications	<table border="1"> <thead> <tr> <th>Environment</th> <th>Tolerance</th> </tr> </thead> <tbody> <tr> <td>Operational Temperature</td> <td>-30°C to +70°C (-22°F to +158°F)</td> </tr> <tr> <td>Storage Temperature</td> <td>-30°C to +80°C (-22°F to +176°F)</td> </tr> <tr> <td>Vibration</td> <td>IEC 60068-2-36</td> </tr> <tr> <td>Shock (drop)</td> <td>IEC 60068-2-32</td> </tr> <tr> <td>Dust / Water</td> <td>IP67</td> </tr> </tbody> </table>	Environment	Tolerance	Operational Temperature	-30°C to +70°C (-22°F to +158°F)	Storage Temperature	-30°C to +80°C (-22°F to +176°F)	Vibration	IEC 60068-2-36	Shock (drop)	IEC 60068-2-32	Dust / Water	IP67
Environment	Tolerance												
Operational Temperature	-30°C to +70°C (-22°F to +158°F)												
Storage Temperature	-30°C to +80°C (-22°F to +176°F)												
Vibration	IEC 60068-2-36												
Shock (drop)	IEC 60068-2-32												
Dust / Water	IP67												
Interface	Single dual color (red and green) LED and single button for user control and tag status												
Size & Weight	94mm H x 58mm W x 14mm D (3.7" H x 2.3" W x 0.55" D) & 45g												
Packaging	FDA Compliant packaging available												

Design

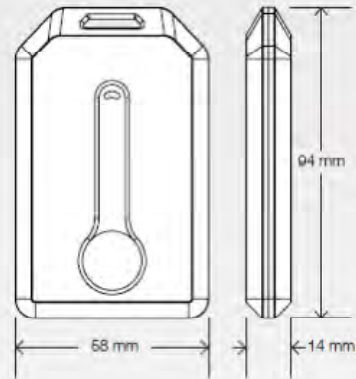

For More Information

To learn more please visit our website or contact us directly. We look forward to hearing from you.

www.intelleflex.com

+1 877 694 3539 Toll Free
+1 408 200 6500 International/Direct

info@intelleflex.com



Intellex HMR-9090

Handheld Barcode/ RFID Reader

- Industry-leading read/write reliability and performance
- Works with Intellex tags to monitor temperature and other conditions inside pallets and containers—without unpacking
- Support for ISO/IEC 18000-6 and EPCglobal C1G2 standards
- Rugged, ergonomic design
- Exceptional ease of use

The Intellex HMR-9090 multi-protocol handheld RFID reader provides superior performance and read/write reliability for a wealth of applications. Built with Intellex XC3 Technology™ it supports ISO/IEC 18000-6 and EPCglobal C1G2 industry standards. It delivers the ability to read/write in RF-challenging environments including metals, liquids and inside packaging and containers.

With the HMR-9090, your mobile workers have a comprehensive on-demand data capture solution that delivers real-time connectivity for mission critical business applications in warehouses and loading docks, as well as worksite or in-transit environments. With the HMR-9090 and Intellex Extended Capability RFID™ tags, you can reliably read and monitor temperature history inside pallets of perishable foods or pharmaceutical packaging—without unpacking or opening the container.

- Perishable food producers, packers, shippers and retailers can easily and cost-effectively track and monitor the temperature of produce on-demand to maximize shelf life and improve quality.
- Pharmaceutical and biologics companies can monitor the temperature inside packaging and containers in transit every step of the way between the factory and the customer to ensure product integrity, efficacy and quality.
- Construction, harvesting and shipping companies can easily monitor assets and products in the field.

The HMR-9090 supports wireless printing and headsets while the ergonomic design provides comfort in scan intensive applications. The HMR-9090's flexible network connectivity and discovery capabilities enable easy integration into existing networks. The multi-user/multi-tasking software supports multiple simultaneous sessions so that applications can interact with the reader, greatly simplifying both system and application design.

Product Features

Advanced Design	High Monostatic Receive Sensitivity High read/write accuracy in very challenging RF environments
	FPGA with Embedded Processor Custom designed for high sensitivity; field upgradeable
	Maximum Transmit Output Power Maximum range with passive tags
	Low Power Consumption Suitable for handheld terminal use
Standards	EPCglobal C1G2 Global interoperability with passive tags
	ISO/IEC 18000-6 Manchester battery assisted passive tags have range over 100 meters
Configurability	Multiprotocol Reader supports C1G2 tags and high performance ISO Class 3 tags
	Performance Profile Tuning Enables performance tuning for speed, range, or balanced mix



The HMR-9090 supports the Intellex Family of Tags:

- STT-8000
- SMT-8100
- SXT-8110
- TMT-8500
- BAT-8300

Specifications

Physical Characteristics	Dimensions	10.75" L x 4.7" W x 7.7" H (27.3 cm x 11.9 cm x 19.5 cm)
	Weight	35.4 oz / 1 kg (includes battery, scanner, and radio)
	Keyboard	53-key; Terminal Emulation (5250, 3270, VT)
	Display	QVGA color
	Power	Removable, rechargeable 7.2 volt Lithium Ion 2200 mAh battery pack, 15.8 watt hours
Processor Characteristics	CPU	Intel® XScale™ Bulverde PXA270 processor at 624 MHz
	Operating System	Microsoft Windows Mobile 5.0/6.1 Premium Edition
	Memory (RAM/ROM)	64 MB/128 MB
	Application Development	PSDK, DCP, and SMDK available through Motorola Developer Zone



Processor Characteristics (continued)	Bar Code Options	2D imaging engine reads symbologies and captures grayscale images and signatures with intuitive laser aiming															
	User Environment	<table border="1"> <tr> <td>Operating Temperature</td> <td>-4° F to 122° F / -20° C to 50° C</td> </tr> <tr> <td>Charging Temperature</td> <td>32° F to 104° F / 0° C to 40° C</td> </tr> <tr> <td>Storage Temperature</td> <td>40° F to 158° F / -40° C to 70° C</td> </tr> <tr> <td>Humidity</td> <td>5% to 95% condensing</td> </tr> <tr> <td>Drop Specification</td> <td>Multiple drops to concrete: 6 ft/1.8 m across the operating temp range</td> </tr> <tr> <td>Tumble</td> <td>2000 one-meter tumbles at room temperature (4000 hits)</td> </tr> <tr> <td>Environmental Sealing</td> <td>IP64 (electronic enclosure, display, and keypad)</td> </tr> <tr> <td>Electrostatic Discharge</td> <td>+/-15 kVdc air discharge; +/-8 kVdc direct discharge; +/-8 kVdc indirect</td> </tr> </table>	Operating Temperature	-4° F to 122° F / -20° C to 50° C	Charging Temperature	32° F to 104° F / 0° C to 40° C	Storage Temperature	40° F to 158° F / -40° C to 70° C	Humidity	5% to 95% condensing	Drop Specification	Multiple drops to concrete: 6 ft/1.8 m across the operating temp range	Tumble	2000 one-meter tumbles at room temperature (4000 hits)	Environmental Sealing	IP64 (electronic enclosure, display, and keypad)	Electrostatic Discharge
Operating Temperature	-4° F to 122° F / -20° C to 50° C																
Charging Temperature	32° F to 104° F / 0° C to 40° C																
Storage Temperature	40° F to 158° F / -40° C to 70° C																
Humidity	5% to 95% condensing																
Drop Specification	Multiple drops to concrete: 6 ft/1.8 m across the operating temp range																
Tumble	2000 one-meter tumbles at room temperature (4000 hits)																
Environmental Sealing	IP64 (electronic enclosure, display, and keypad)																
Electrostatic Discharge	+/-15 kVdc air discharge; +/-8 kVdc direct discharge; +/-8 kVdc indirect																
RFID	Standards Supported	EPCglobal C1G2, ISO/IEC 18000-6 (Manchester mode BAP)															
	Nominal Read Range (C1G2)	0.2 ft to 10 ft / 6 cm to 305 cm															
	Nominal Read Range (C3)	0.2 ft to 100 ft / 6 cm to 30 m															
	Nominal Write Range (C1G2)	1 ft to 2 ft / 30 cm to 61 cm															
	Nominal Write Range (C3)	0.2 ft to 50 ft / 6 cm to 15 m															
	Field	70-degree cone (approx.) measured from nose of device															
	Antenna	Integrated, linearly polarized															
	Frequency Range	US: 902-928 MHz; Europe 865.7-867.5 MHz															
	Output Power	US: 1 W (2W EIRP); Europe 0.5 W															
	C1G2 PIE Forward Link Tari	25 - 6.25 usec															
	C3 Manchester Forward Link Rates	8 - 128 Kbps															
	Miller Backscatter Link Frequencies, M Ratio	BLF: 80 - 320 KHz, M: 4 - 128															
	Reverse Link Data Rates (BLF/M)	2.5 - 80 Kbps															



The TMT-8500 Temperature Monitoring Tag provides the ability to access temperature data on-demand without unpacking pallets or opening containers.



Wireless Data Communication	WLAN	802.11 a/b/g
	Output Power	100 mW (US, International)
	Data Rate	Up to 54 Mbps
	Antenna	Internal
	Frequency Range	Country dependent (802.11a-5 GHz, 802.11b/g-2.4 GHz)
	PAN (Bluetooth Support)	Bluetooth Version 1.2 with BTExplorer (manager) included
Peripherals and Accessories	Cradles	Single-slot serial/USB, 4-slot Ethernet, 4-slot charge only
	Printers	Supports extensive line of printers and cables
	Charger	4-slot universal battery charger
	Other Accessories	Cable adapter module; snap-on magnetic stripe reader; modem module; full set of cables
Regulatory	General	Approved for use in the United States; additional countries in process
	Electrical Safety	Certified to UL60950-1, CSA C22.2 No. 60950-1, IEC 60950-1
	EMI/RFI Radio Versions	US: FCC Part 2 (SAR), FCC Part 15, RSS210 Europe: EN 301-893, EN 300 328, EN60950-1
	Laser Safety	IEC Class 2/FDA Class II in accordance w/IEC 60825-1, 21CFR1040.10
Warranty	The HMR-9090 is warranted against defects in workmanship and materials for a period of one year (12 months) from date of shipment, provided the product remains unmodified and is operated under normal and proper conditions	

For More Information

To learn more please visit our website or contact us directly. We look forward to hearing from you.

www.intelleflex.com

+1 877 694 3639 Toll Free

+1 408 200 6500 International/Direct

info@intelleflex.com

Ordering Information - FPO

Part Number	Description
HMR-9090 RFID Reader	HMR-9090 RFID Reader; North America 902 – 928 MHz frequency band

Specifications are subject to change without notice.

Tags - A927Z Temperature Logger UHF Semi-Passive Tag Datasheet



- **EPC C1G2 (ISO18000-6C) Compatible**
- **Frequency range: 860 MHz ÷ 928 MHz**
- **Read range: approx. 10m in air (2.5m on metal) @ 2W ERP**
- **Unique ID plus long EPC code (512 bit)**
- **Memory capacity: 8000 samples (16 kbyte)**
- **Programmable sampling interval**
- **Programmable temperature thresholds**
- **Battery life: 3 or 5 years**
- **Temperature range: -20°C to +70°C**
- **±0.1°C Accuracy (typical)**
- **No calibration required**
- **Dimensions: 130.4x23.4x12.7 mm³**
- **Battery charge measurement through RF**

CAEN RFID's EASY2LOG® Temperature Logger Mod. A927Z is a low cost, semi-passive UHF tag that allows monitoring of temperature sensitive products during transportation or storage.

Being compliant to the EPC Class1 Gen2/ISO18000-6C standards, EASY2LOG® can be used with most of the Gen2 UHF RFID readers on the market without requiring any additional equipment.

The Logger is configurable either in Continuous or Over-Threshold logging modes, allowing the storage of up to 8000 temperature samples with programmable sampling times. Once programmed, the tag will start to monitor the life of your temperature sensitive product, thus allowing to identify any problems occurred along the whole cold chain by just performing an inventory cycle.

The EASY2LOG® temperature logger is recommended for recording temperatures during transportation and/or storage of temperature-sensitive goods such as:

- Fresh food (fruit, vegetables)
- Seafood
- Meat and poultry
- Milk-based products
- Frozen food
- Chemical/pharmaceutical products

WORKABOUT PRO

Specifications



Model Variants

- WORKABOUT PRO C - Model 7527C-G2
- WORKABOUT PRO S - Model 7527S-G2

Platform

- PXA270 520 MHz, 32 bit RISC CPU
- 256 MB Flash ROM
- 128 MB RAM

Operating System

- Windows® CE 5
- Windows Mobile® 6 Classic, Professional



Wireless Communications

- Optional expansion modules for:
- 802.11a/b/g Compact Flash Radio available on C model
 - 802.11b/g Compact Flash Radio available on all models
 - GPRS EDGE - 850/900/1800/1900 Voice and Data
 - 3G HSDPA - 850/1900/2100MHz Voice and Data
 - Integrated Bluetooth® Class II, V 2.0 + EDR
 - Note: All expansion modules are available factory configured or user installable



Barcode Applications

- 1D laser scanning in standard range, long range, and auto range configurations
- 1D linear imager
- 2D area imager
- Optional bolt-on pistol grip



RFID Module Options

- HF Module
 - Frequency: 13.56 MHz
 - Tags supported: ISO 15693, Philips® ICode™, TI TagIt™; Tagsys (C210, C220, C240, C270)
 - Read/write range up to: 3.15 in (8 cm)
- MIFARE™ module
 - Frequency: 13.56 MHz
 - Tags supported: ISO 14443 A&B, MIFARE™
 - Read/write range up to: 1.97 in (5 cm)
- LF module
 - Frequency: 125 KHz, 134.2 KHz
 - Tags supported: EM 4x0x, EM 4x50; Hitag 1 & 2; ISO HDXA & FDXD
 - Read/write range up to: 2.76 in (7 cm)
- UHF module
 - Frequency: 868 MHz or 915 MHz
 - Tag supported: EPC Class 1 Gen 2, other protocols depending on regions
 - Read range up to: 98.425 in (250 cm)



External Connectors

- One tether connection with full RS232 and USB On-The-Go (USB 1.1) functionality
- One Low-Insertion Force (LIF) docking connector
- DC Power Jack

User Interface

- Color / Touch display
 - 3.7 in (9.398 cm)
 - Full VGA 480 x 640 resolution
 - Transflective, portrait mode TFT
 - Sunlight readable (for outdoor use)
 - High-reliability adjustable LED Backlight featuring a bright 165 cd/m² output
- Touchscreen (standard)
 - Passive stylus or finger operation
 - Signature capture
- Keyboards
 - Full alpha-numeric (C model)
 - Numeric (S model)
 - Backlit, high durability hard-capped keys
- Audio
 - 90 db mono speaker
 - Mono microphone
 - 86 db beeper standard
 - 95 db beeper w/ auto range laser

Programming Environment

- HTML, XML
- Psion Mobile Devices SDK
- Hardware Development Kit (HDK)
- .NET and C++ programming using Microsoft® Visual Studio® 2005
- Java programming supporting JDK 1.2.2 or higher
- Standard Protocol APIs Windows® sockets (CE.net)



Application Software

- Internet Explorer® 6.0
- Psion Voice Dialer and Contacts Manager incl. Windows® CE 5
- PTX Connect VoIP
- Terminal emulation software, supports IBM 5250, IBM 3270, HP2392, ANSI and TESS
- Mobile Control Centre (MCC) device management

Expansion Slots

- One SD/MMC memory card slot
- End-cap USB Interface supports GPS expansion module.
- 100-PIN expansion interface: supports PCMCIA (type II), GPRS/EDGE and other third-party expansion modules developed using Psion Hardware Developer's Kit
- Flex cable interface supports scanner (serial) and imager (USB) modules
- One Type II CF Card Slot

Power Management

- Optional 3.7V, 3300 mAh standard capacity battery
- Optional 3.7V, 4400 mAh high capacity battery
- Advanced smart battery with gauge
- Built in charger
- Rechargeable, user replaceable backup battery pack

Environmental

- Withstands multiple drops from 6 ft (1.8 m) or 26 drops (on 12 edges, 6 corners, 8 faces) from 5 ft (1.5 m) to concrete while powered on and configured with accessories such as WiFi radio, scanner / imager and pistol grip.
- Rain/Dust: IP65, IEC 60529
- Operating temperature: -4°F to 122°F (-20°C to +50°C)
- 5%-95% RH non-condensing
- Storage temperature: -40°F to 140°F (-40°C to +60°C)
- ESD: +/- 8kVdc air discharge, +/-4kVdc contacts

Physical Dimensions

- WORKABOUT PRO C: 8.78" x 2.95"/3.94" x 1.22"/1.65" (223 mm x 75/100 mm x 31/42 mm)
- WORKABOUT PRO S: 7.87" x 2.95"/3.94" x 1.22"/1.65" (200 mm x 75/100 mm x 31/42 mm)

Approvals

- Safety: CSA/UL60950-1, IEC 60950-1, EN60950-1
- EMC: FCC Part 15 Class B
- EN 55022
- EN 55024
- EN301 489
- Laser: IEC 60825-1, Class 2
- FDA 21 CFR 1040.10, 1040.11 Class II
- Bluetooth®: 1.2
- In Vehicle Cradle: e Mark

A complete list of accessories is available at: www.pSION.com



Product is ROHS Compliant.

* Note this product will carry the CE Mark. * Specifications are subject to change without notice.



WORKABOUT PRO

For more information, please visit www.pSIONteklogix.com

© Psion Inc., Psion, Psion Teklogix, Ikon, NEO, Omnil and WORKABOUT PRO 2 are registered trademarks or trademarks of Psion PLC and subsidiaries. Other products mentioned in this document may be trademarks of Psion Inc. or trademarks or registered trademarks of other software, hardware or service providers and are used herein for identification purposes only. Windows and the Windows logo are trademarks or registered trademarks of Microsoft Corporation in the United States and/or other countries. 4.07109