

REPORT DOCUMENTATION PAGE

Form Approved
OMB No. 0704-0188

Public reporting burden for this collection of information is estimated to average 1 hour per response, including the time for reviewing instructions, searching existing data sources, gathering and maintaining the data needed, and completing and reviewing this collection of information. Send comments regarding this burden estimate or any other aspect of this collection of information, including suggestions for reducing this burden to Department of Defense, Washington Headquarters Services, Directorate for Information Operations and Reports (0704-0188), 1215 Jefferson Davis Highway, Suite 1204, Arlington, VA 22202-4302. Respondents should be aware that notwithstanding any other provision of law, no person shall be subject to any penalty for failing to comply with a collection of information if it does not display a currently valid OMB control number. **PLEASE DO NOT RETURN YOUR FORM TO THE ABOVE ADDRESS.**

1. REPORT DATE (DD-MM-YYYY) 27-10-2011		2. REPORT TYPE Briefing Charts		3. DATES COVERED (From - To)	
4. TITLE AND SUBTITLE Summer Co-op Outbrief: Themis Cavitating Venturi Resonance Study				5a. CONTRACT NUMBER	
				5b. GRANT NUMBER	
				5c. PROGRAM ELEMENT NUMBER	
6. AUTHOR(S) Phuoc Hai Tran				5d. PROJECT NUMBER	
				5f. WORK UNIT NUMBER 33SP0795	
7. PERFORMING ORGANIZATION NAME(S) AND ADDRESS(ES) Air Force Research Laboratory (AFMC) AFRL/RZSE 4 Draco Drive Edwards Air Force Base CA 93524-7160				8. PERFORMING ORGANIZATION REPORT NUMBER	
9. SPONSORING / MONITORING AGENCY NAME(S) AND ADDRESS(ES) Air Force Research Laboratory (AFMC) AFRL/RZS 5 Pollux Drive Edwards AFB CA 93524-7048				10. SPONSOR/MONITOR'S ACRONYM(S)	
				11. SPONSOR/MONITOR'S NUMBER(S) AFRL-RZ-ED-VG-2011-436	
12. DISTRIBUTION / AVAILABILITY STATEMENT Distribution A: Approved for public release; distribution unlimited (PA#11930).					
13. SUPPLEMENTARY NOTES Thesis Presentation, University of California at Los Angeles, December 2011.					
14. ABSTRACT This presentation examines the propagation and properties of acoustic disturbances caused by cavitating venture at different operating regimes. Issues of interest are effects on cold flow and water visualization jets (injectors) and the Big Picture: LRE systems. There is a lack of literature pertaining to unsteady characteristics. Theory is explored, along with test details for design space, test facility, test apparatus, and preliminary results.					
15. SUBJECT TERMS					
16. SECURITY CLASSIFICATION OF:			17. LIMITATION OF ABSTRACT	18. NUMBER OF PAGES	19a. NAME OF RESPONSIBLE PERSON
a. REPORT	b. ABSTRACT	c. THIS PAGE			Mr. Nils M. Sedano
Unclassified	Unclassified	Unclassified	SAR	41	19b. TELEPHONE NUMBER <i>(include area code)</i> N/A



Summer Co-op Outbrief: Themis Cavitating Venturi Resonance Study



Phuoc Hai Tran
Research Engineer Summer Intern
AFRL/RZSE/JNT



Biography



- **Phuoc Hai N. Tran**

- Henry Samueli School of Engineering & Applied Science, University of California: Los Angeles

- Aerospace Engineering B.S. (2013) in progress
- UCLA AIAA HyPE Rocket Project
- UCLA Energy Innovation Laboratory
- 2010–2011 Vishal Parikh Memorial Scholarship Recipient



- For outstanding academic achievement coupled with a strong interest in the field of Rocket Propulsion.

- **Interests**

- Jet Propulsion, Fluid Dynamics, Aerodynamics
- Aerospace (Rocketry/Aviation), Cars, Computer Technology, Photography



Study Introduction

Background and Theory



Background and Relevance

Research Objective:

- ❖ *Examine the propagation and properties of acoustic disturbances caused by cavitating venturi at different operating regimes*



Fig1. Insert-type Cavitating Venturi Profile
(AFRL/RZOP, 2011)

- **Extensive use in LREs**
 - Precise passive flow rate control
 - Themis Cold Flow
 - Themis Water Visualization Study
 - System isolation
 - Combustion instability mitigation
- **Issues of interest**
 - Effects on cold flow and water visualization jets (Injectors)
 - Big Picture: LRE systems
- **Lack of literature pertaining to unsteady characteristics**



Theory

- **Mass Flow Rate derived from Bernoulli's Equation**

- Dependent only on P_1 and P_v

$$\dot{m} = C_d A_{th} \sqrt{2\rho(P_1 - P_v)}$$

- **Flow is “choked” through a combination of phenomena**

- Occurs when $R_p \sim 0.85$
- Independent of P_2 and any changes to downstream pressure

- **Dimensionless Variables**

Cavitation Number | Pressure Ratio

$$\sigma = \frac{P_1 - P_v}{P_1 - P_2} \quad R_p = \frac{P_2}{P_1}$$

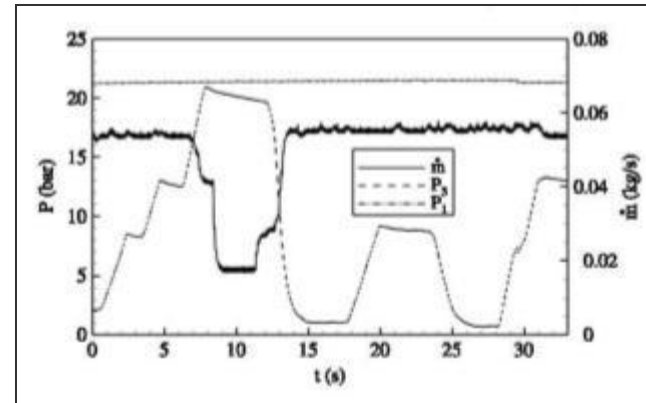

Fig2. Mass Flow and Pressure Ratio versus Time
(Ghassemi & Fasih, 2011)

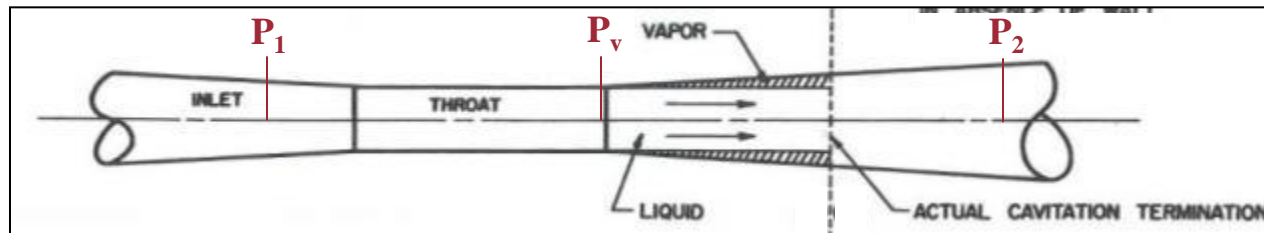

Fig3. Detailed Typical Venturi Cross Section
(Hammit & Robinson, 1966)



Theory

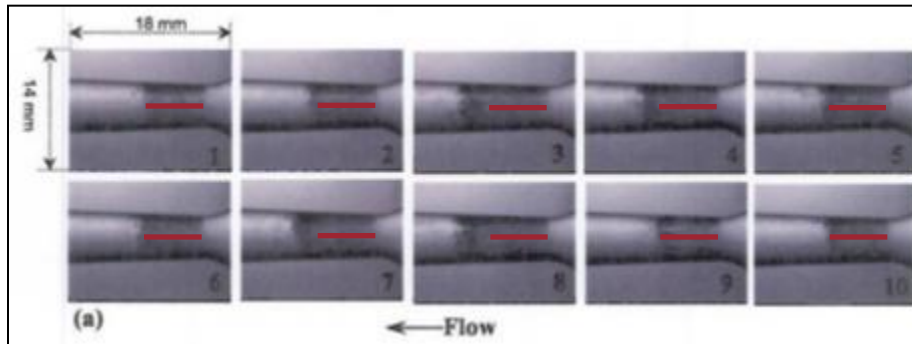

Fig4. Cavitation Length Fluctuation Over Time
(Sayyaadi, 2010)

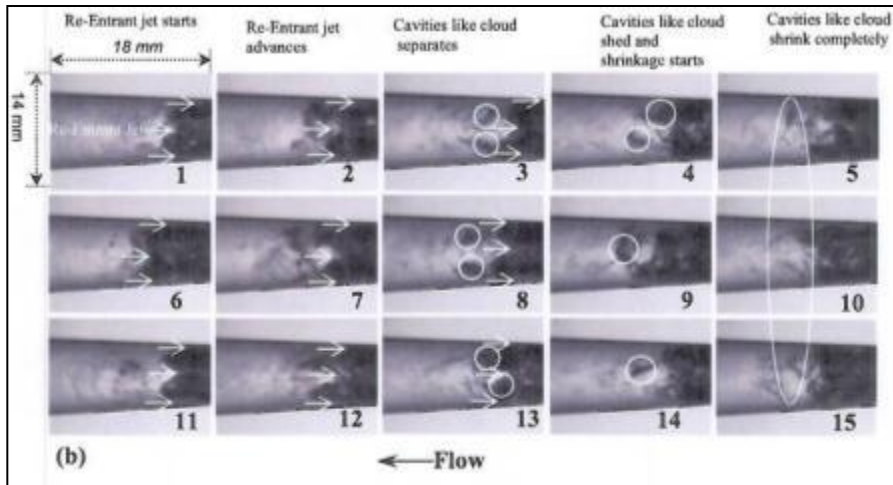

Fig5. Unsteady Flow Phenomena at Cavitation Front
(Sayyaadi, 2010)

- **Inherently unsteady process**
- **Sparse data and results**
 - Poor frequency response of static pressure and mass flow sensors
 - Difficult to model in CFD
 - Disparity between experimental and computational studies
- **Strouhal number** $St = \frac{fL_c}{V_{th}}$
 - Characterize disturbances
 - Function of cavitation number
 - Range of 0.015 to 0.45 (depending on literature source)



Test Details

Design and Implementation



Design Space



- **Test Variables**

- Upstream pressure [P_1]
- Downstream (Back) pressure [P_2]
- Venturi Geometry

- **Test Measurements**

- Pressure Readings
 - Fluctuations at pressure stations of varying L/D position
- Mass Flow Rate
 - Catch and weigh

- **Sample Conditions**

- 0.035" ID, 1.3" L_c , 800 psi P_1
 - Frequency Range: 60 to 1400 Hz
 - Throat Dynamic Pressure: 799 psi
 - Mass Flow Rate: 0.144 lbm/sec

- **Instrumentation Selection**

- Kistler 603B1 with 223A Adapter
 - Wall Flush, Dynamic Reading
 - Easily resolves frequency
 - Easily handles pressure spikes
- Kistler 5010B Dual Mode Amplifier
 - Select pressure range

- **Issues and Constraints**

- Time, Cost, Availability

Pressure Range	psi	15000
Calibrated Partial Range	%	1,10
Maximum Pressure without damage	psi	18000
Sensitivity nom.	pC/psi	-0.35
Threshold (charge amplifier noise)	psi	0.01
Amplitude Non-linearity zero based BFSL	%FSO	±1
Hysteresis	%FSO	1
Insulation Resistance at R.T.	Ω	10^{13}
Resonant Frequency nom.	kHz	500



Fig6. Kistler 603B1 Technical Data Excerpt
(Kistler Instrumentation Corp., 2003)



Design Space

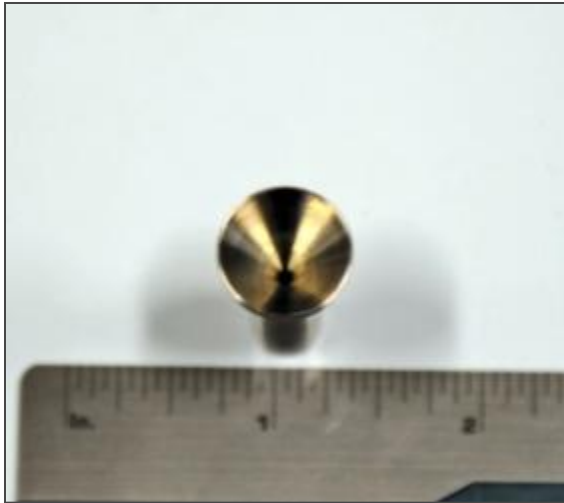

Fig8. Venturi Inlet (0.047")
(AFRL/RZOP, 2011)



Fig9. Venturi Profile (0.047")
(AFRL/RZOP, 2011)



Fig10. Venturi Outlet (0.047")
(AFRL/RZOP, 2011)

D_{throat}	$D_{exit, outer}$	$D_{exit, inner}$	$D_{inlet, outer}$	Wall Thickness _{inlet}	$D_{inlet, inner}$	L_{total}	L_{inlet}	$L_{exit} (L_c)$
0.047	0.3435	0.1829	0.6272	0.0161	0.595	1.2348	0.2512	0.9836
0.0595	0.3761	0.2185	0.6549	0.0147	0.6255	1.4934	0.2348	1.2586
0.027	0.3432	0.1899	0.6258	0.0149	0.596	0.8652	0.258	0.6072

Fig11. Venturi Dimensions
(Phuoc Hai Tran AFRL/RZSE, 2011)



Design Space

- **Simple Cases**

- Vary only by R_p
 - Set only “Back Pressure” during runs

- **Wide Data Range**

- Many comparisons possible
- Spaced for wide σ and R_p spread

- **Case Overview**

- 3 Venturi inserts
- 4 Inlet pressures
- 17 Back pressures
- 204 Test runs
- 15 Seconds per pressure data run
- 5 Minutes per venturi mass flow run
- 10 Minute venturi recycle time

Inlet Pressure	Back Pressure	Cavitation Number	Pressure Ratio
1500	1406.3	15.99	0.94
	1387.5	13.33	0.93
	1368.8	11.42	0.91
	1350.0	10.00	0.90
	1312.5	8.00	0.88
	1275.0	6.66	0.85
	1237.5	5.71	0.83
	1200.0	5.00	0.80
	1125.0	4.00	0.75
	1050.0	3.33	0.70
	975.0	2.86	0.65
	900.0	2.50	0.60
	750.0	2.00	0.50
	600.0	1.67	0.40
	450.0	1.43	0.30
	300.0	1.25	0.20
	150.0	1.11	0.10

Inlet Pressure	Back Pressure	Cavitation Number	Pressure Ratio
1000	937.5	15.99	0.94
	925.0	13.33	0.93
	912.5	11.42	0.91
	900.0	10.00	0.90
	875.0	8.00	0.88
	850.0	6.66	0.85
	825.0	5.71	0.83
	800.0	5.00	0.80
	750.0	4.00	0.75
	700.0	3.33	0.70
	650.0	2.86	0.65
	600.0	2.50	0.60
	500.0	2.00	0.50
	400.0	1.67	0.40
	300.0	1.43	0.30
	200.0	1.25	0.20
	100.0	1.11	0.10

Fig7. Experiment Test Matrix
(Phuoc Hai Tran AFRL/RZSE, 2011)



Test Facility



- **1-14 Flow Lab**

- Test medium
 - Deionized water
- System capabilities
 - Upstream run pressures of up to 2000 psi via regulator
 - Downstream run pressure down to 14 psi via throttle valve
 - Flow Rate of up to ~20 gpm
 - Water degasification system
- Main systems
 - Water tank pressurize
 - Water tank degasify
 - Water tank fill
 - Water run
- Fast recycle time

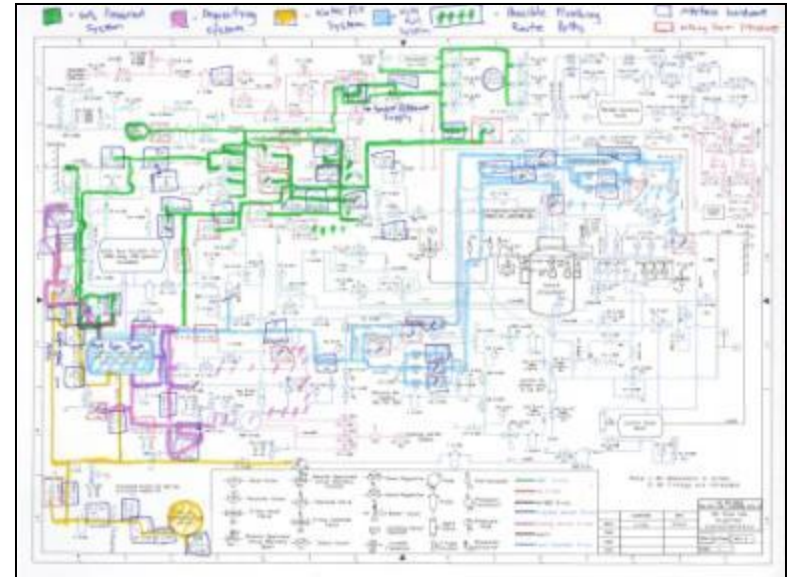

Fig12. Flow Lab PID with Main Systems
(Edgar Felix AFRL/RZSA, July 2011)

- **Safety Considerations**

- Pressurized vessels
- High noise level
 - Venturi ringing
 - Line and tank venting



Test Facility



Fig13. Main Water Tank and Line Pressurization Regulators
(AFRL/RZOP, 2011)

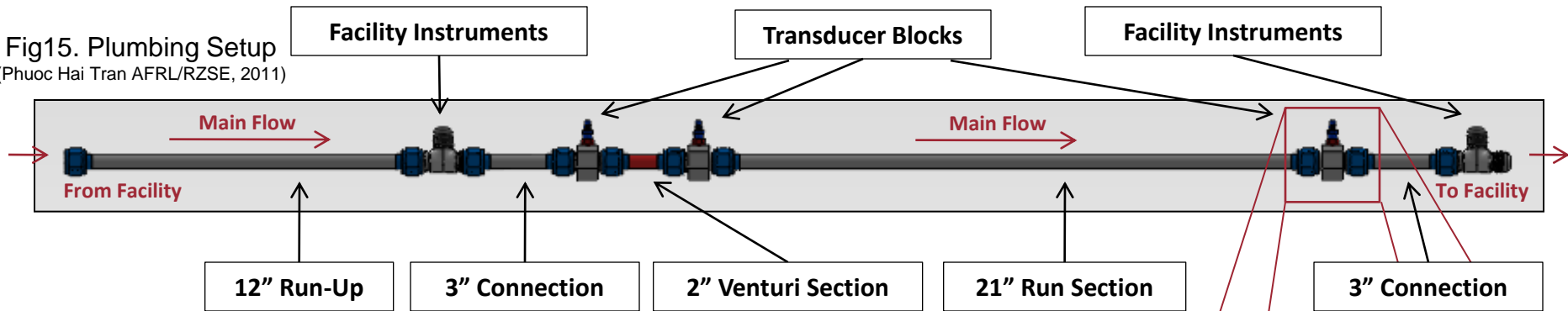

Fig14. Water Tank and Rear Pressure Regulator Panel
(AFRL/RZOP, 2011)



Test Apparatus

Fig15. Plumbing Setup
(Phuoc Hai Tran AFRL/RZSE, 2011)



• Hardware

- 0.049" Wall stainless steel AN-08
 - Rated to over 3500 psi
- Integrated into 1-14 Flow Loop
 - (~ 38 L/D) • 6' total length
 - (~ 48 L/D) • ~17" Run-up to Venturi
 - ~23" Run to downstream block

• Instrumentation

- Facility Instruments
 - AN-08 Cross
 - AN-08 Tee
 - 2x Static PTs
 - 1x Thermocouple
- 3x Transducer Blocks
 - Custom design
 - AN-08, 304 Stainless
 - Wall flush
 - Dynamic PTs

(Not Shown)

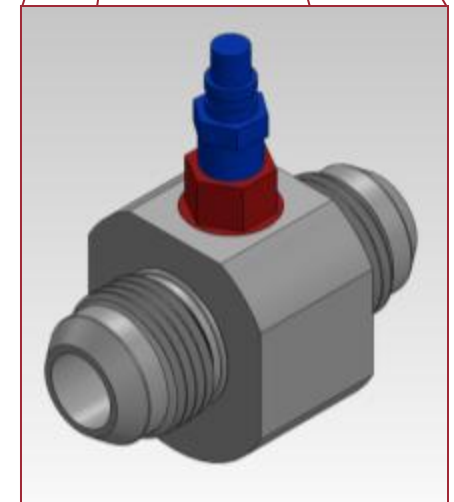

Fig16. Transducer Block with PT
(Phuoc Hai Tran AFRL/RZSE, 2011)



Test Apparatus

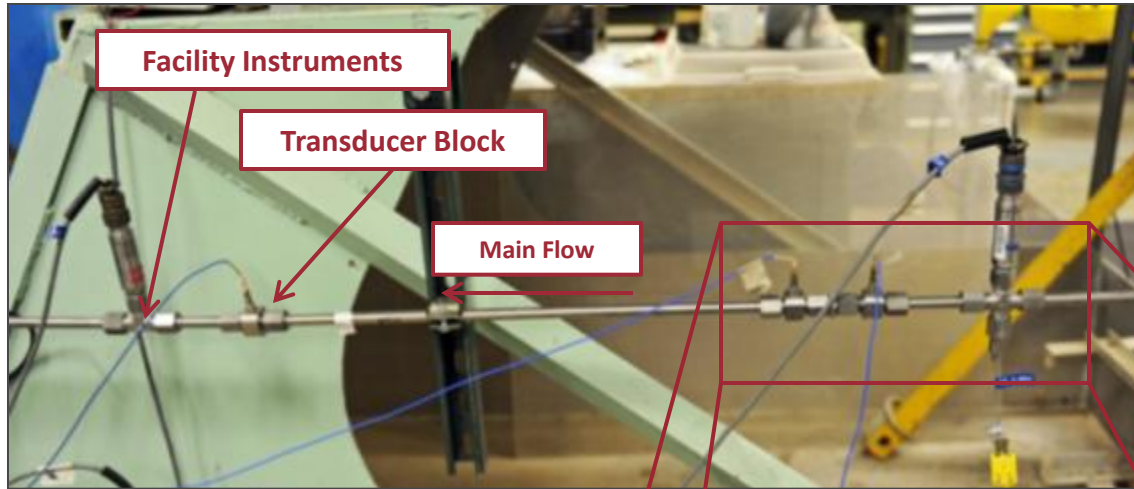

Fig17. Test Apparatus in Flow Loop
(AFRL/RZOP, 2011)



Fig18. Kistler 5010B Signal Processing Units
(AFRL/RZOP, 2011)

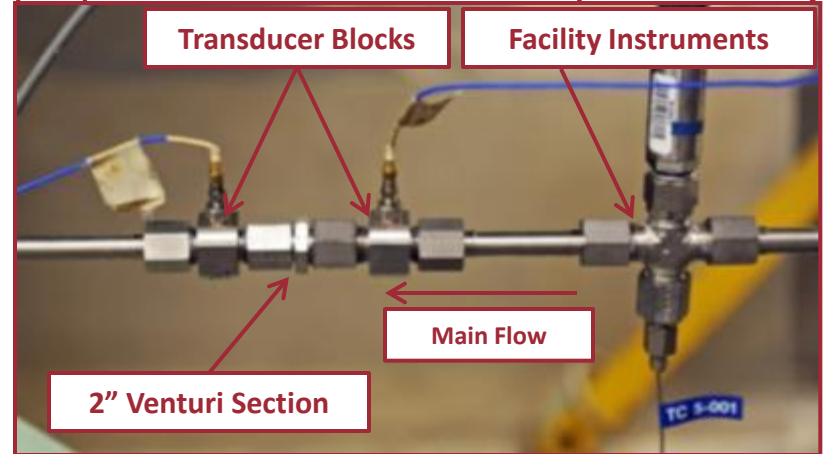

Fig19. Close-up of Venturi Section with Transducer Blocks with fitted Kistler 6031B Transducers
(AFRL/RZOP, 2011)

Distribution A. Approved for public release; distribution unlimited



Preliminary Results

Cavitating Region Characteristics



Test Notes & Observations



- **DAQ Sampling Selection: 2 seconds @ 100,000 Hz**
 - Sampling rate high enough to resolve frequencies
 - Sample length long enough for multiple analyses
- **Amplifier Scale adjusted for optimum resolution**
 - Varied between runs according to flow regime
- **Audible flow regime transitions**
- **Mass flow measurements**
 - 750psi case discarded in the interest of time
 - Anomalous 0.0595" Venturi mass flow results



Analysis Notes



- **High frequency raw data in mV**
 - Convert to psi using correct scale

- **Pressure amplitude (psi) data**
 - Take mean of absolute value of converted pressure data

- **Frequency signatures of raw data**
 - Fast Fourier Transform (FFT) on each data set
 - 4096 samples, 50 runs each, frequency resolution of ~24 Hz



System Baseline



- **Flow through apparatus without venturi**
- **Lower frequency modes**
 - Spectra resembles that of turbulent flow
- **Similar frequency modes in non-cavitating test runs**
 - Dominated by lower frequency modes
- **Low average pressure amplitude**
 - Order of 1.0 psi



System Baseline

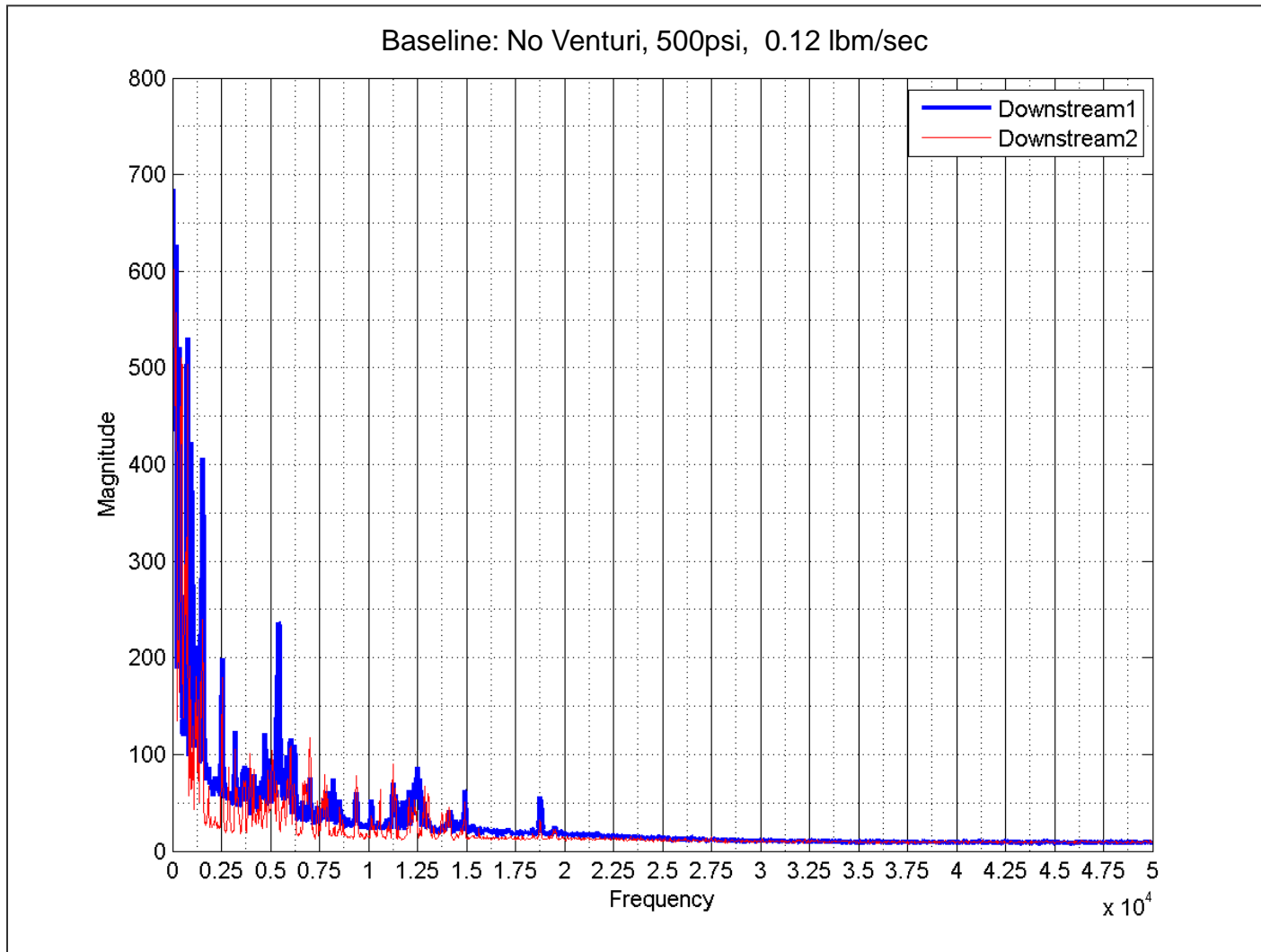

Fig20. Baseline FFT Plot
(Phuoc Hai Tran AFRL/RZSE, 2011)

Distribution A. Approved for public release; distribution unlimited



System Baseline

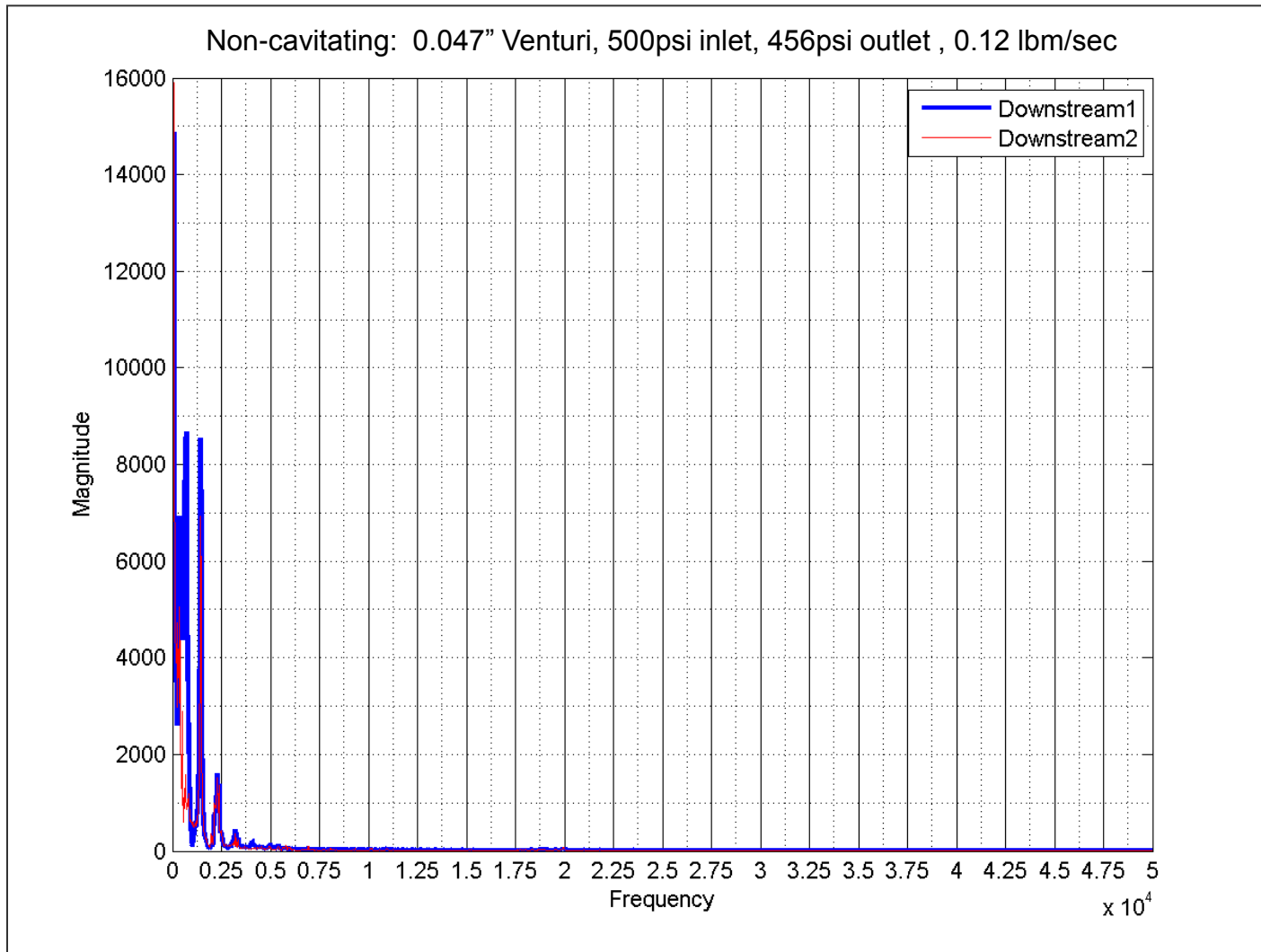

Fig21. Non-cavitating FFT Plot

(Phuoc Hai Tran AFRL/RZSE, 2011)

Distribution A. Approved for public release; distribution unlimited



Pressure Amplitudes and Attenuation

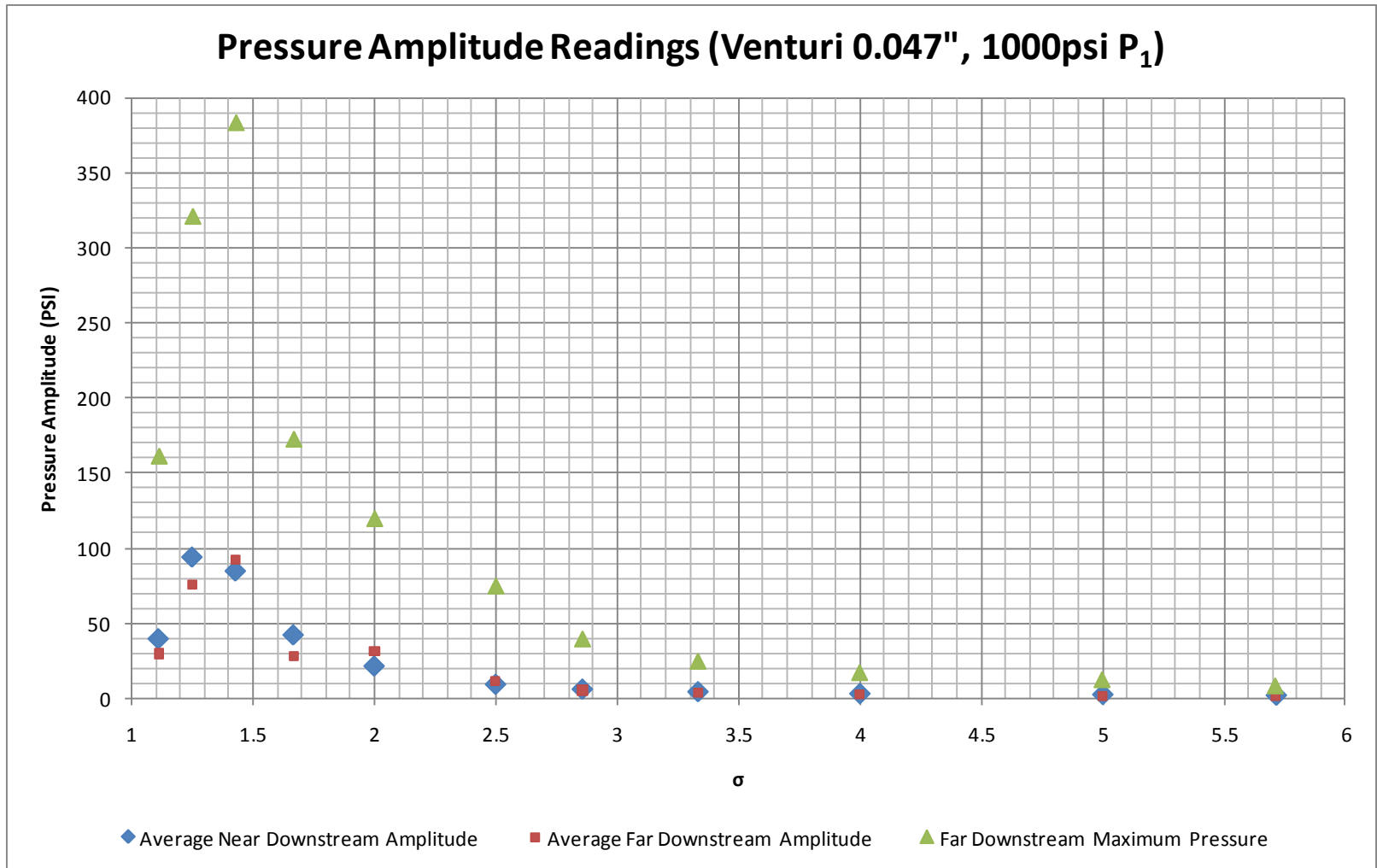

Fig22. Pressure Amplitude Plot
(Phuoc Hai Tran AFRL/RZSE, 2011)



Frequency Analysis

$$St = \frac{fL_c}{V_{th}}$$

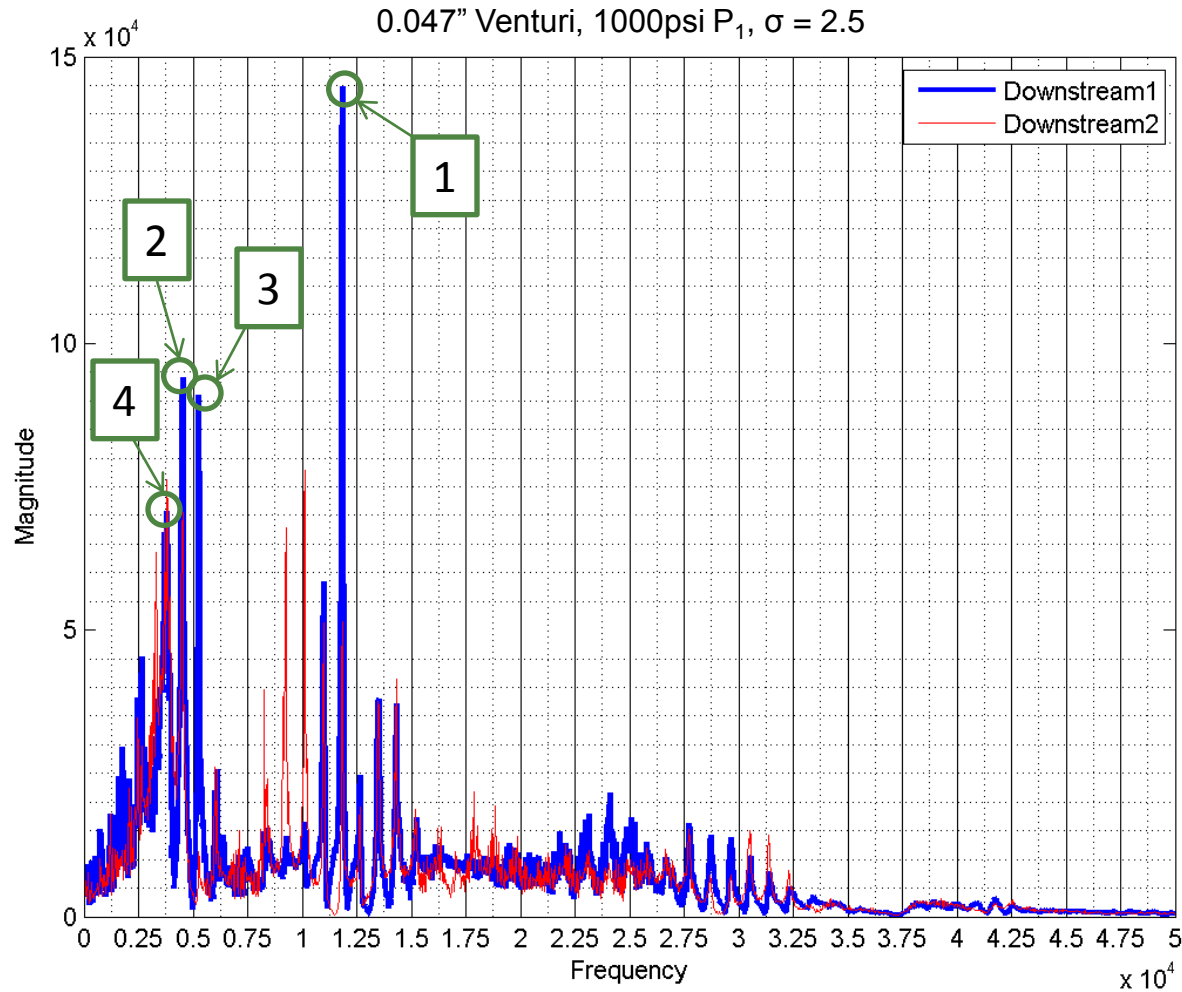

Fig23. FFT Sample Analysis
(Phuoc Hai Tran AFRL/RZSE, 2011)

Distribution A. Approved for public release; distribution unlimited



Frequency Analysis

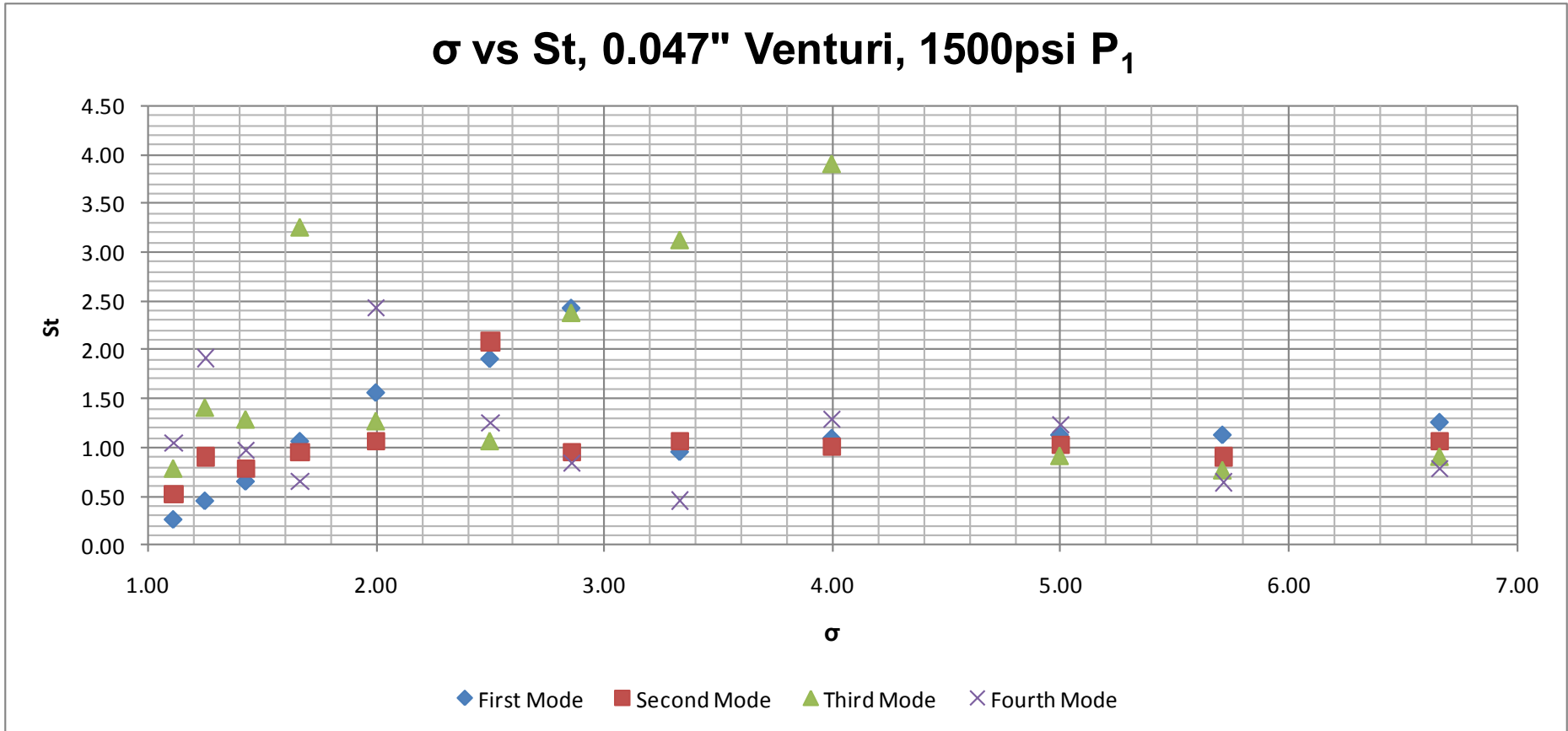

Fig24.
(Phuoc Hai Tran AFRL/RZSE, 2011)



Frequency Signature

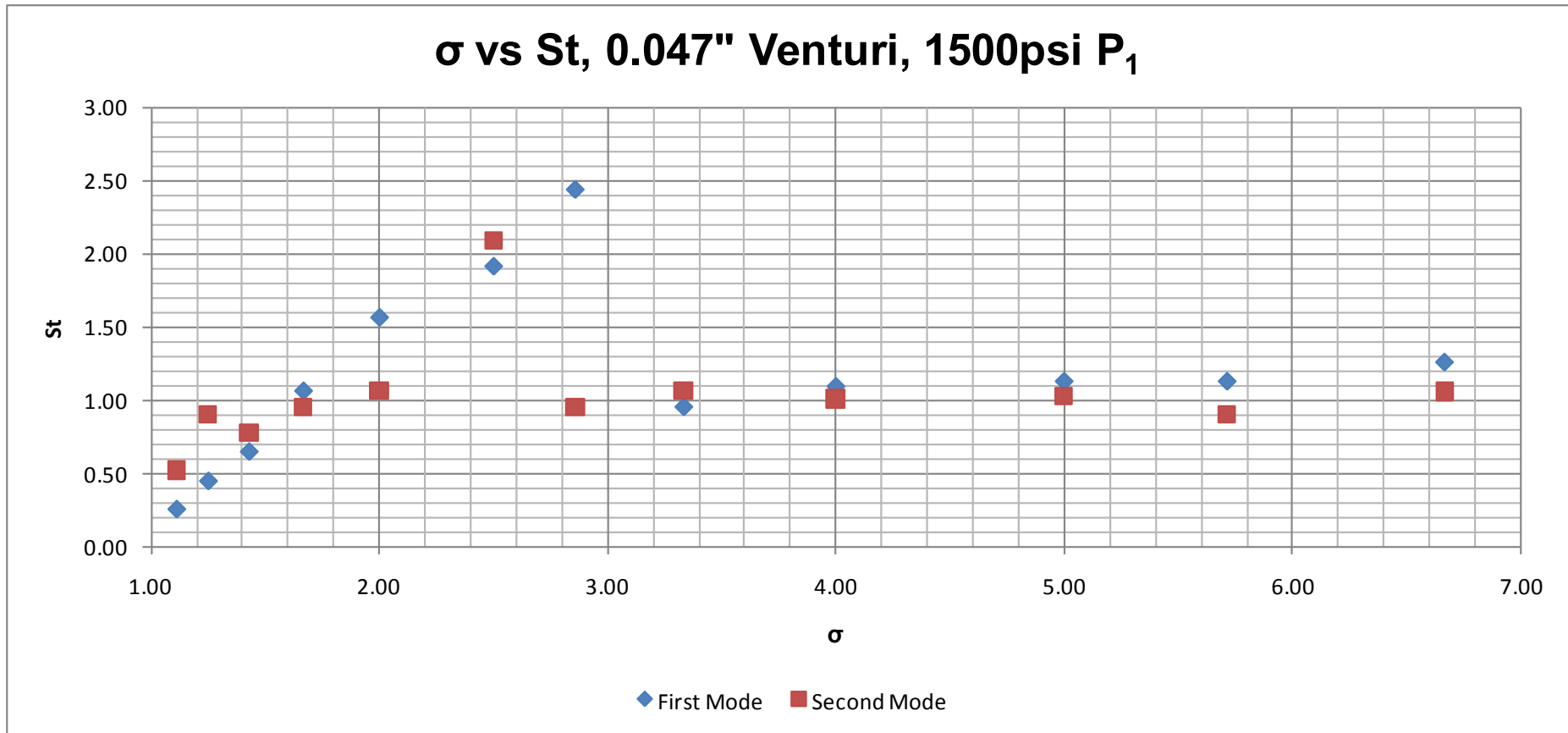

Fig25.
(Phuoc Hai Tran AFRL/RZSE, 2011)



Frequency Signature

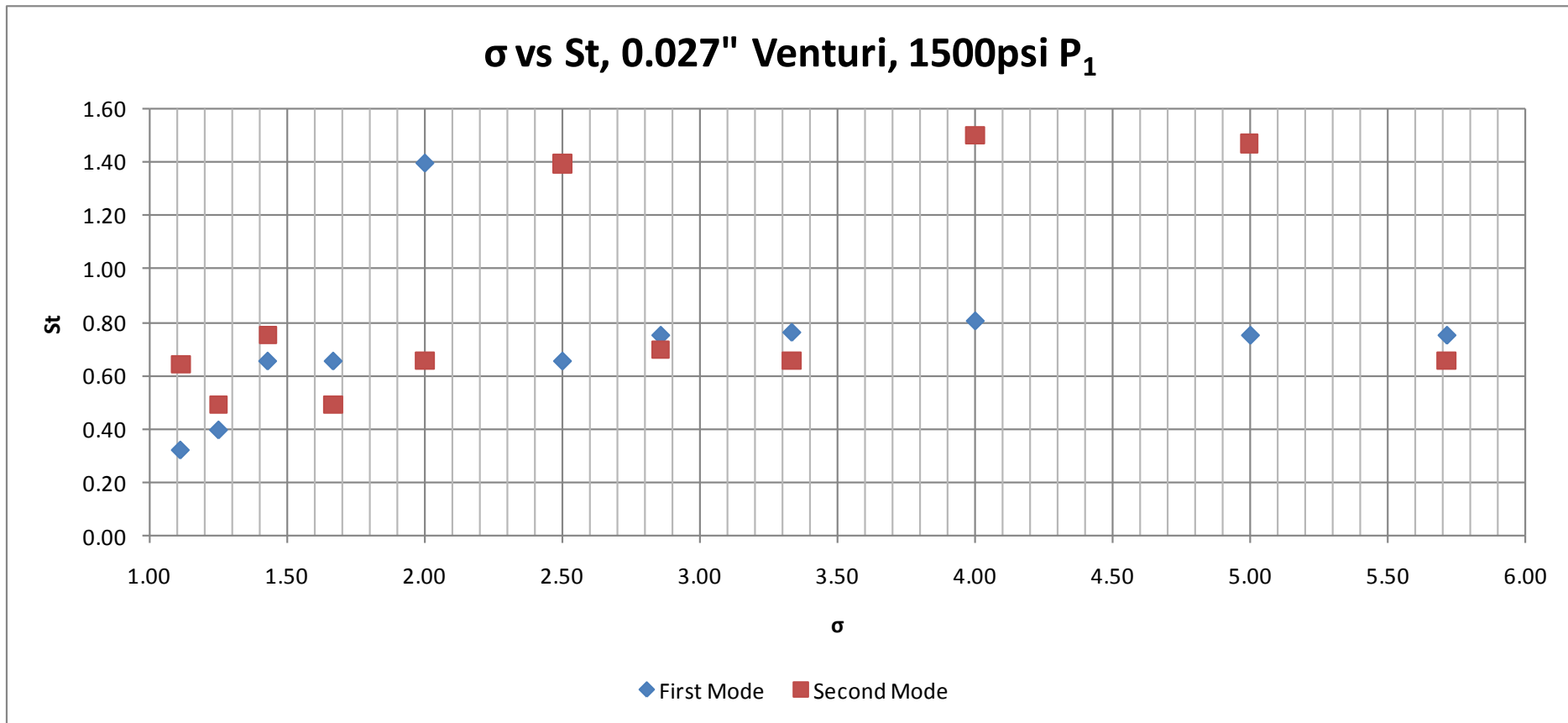

Fig26.
(Phuoc Hai Tran AFRL/RZSE, 2011)



Frequency Signature

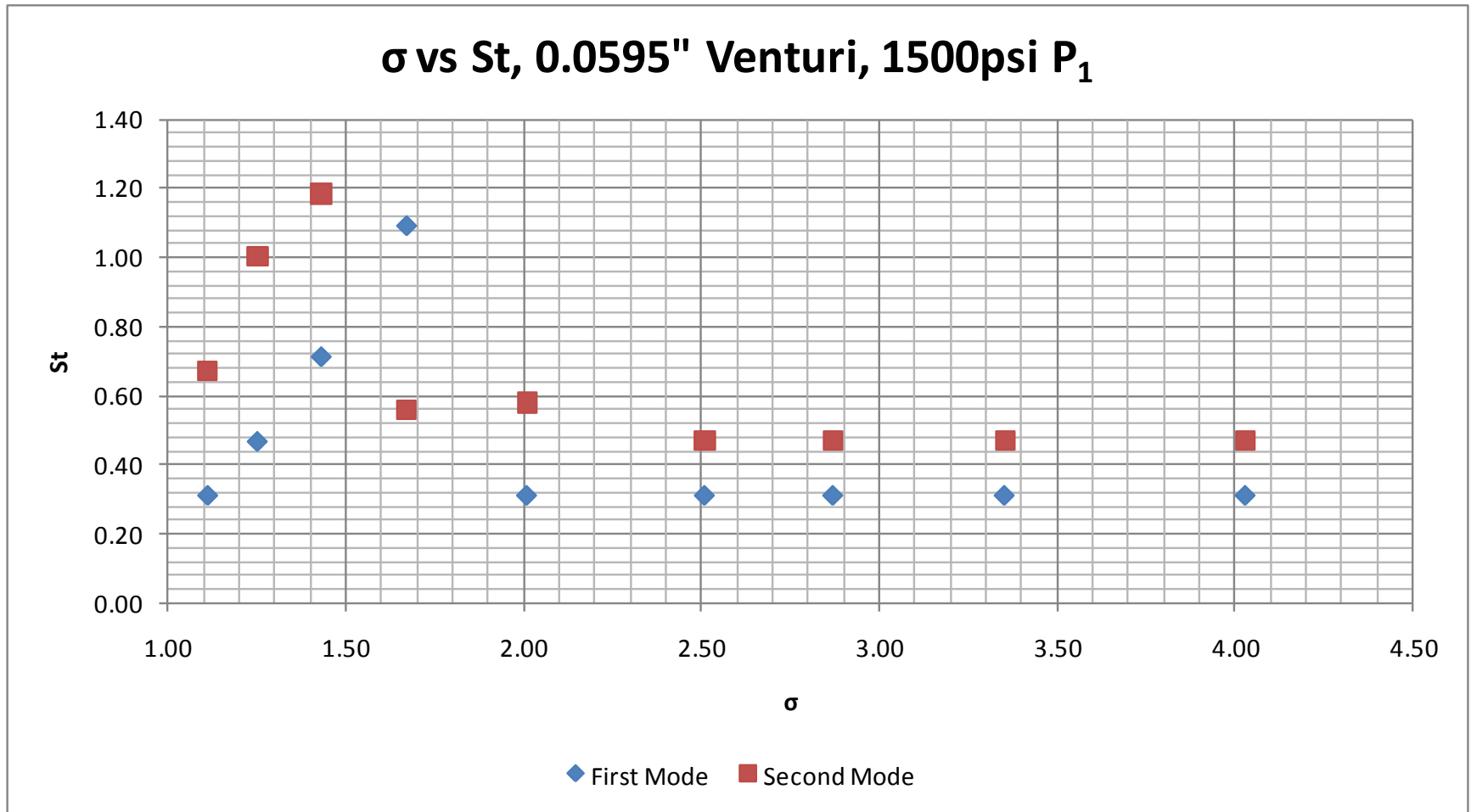

Fig27.
(Phuoc Hai Tran AFRL/RZSE, 2011)



Frequency Signature

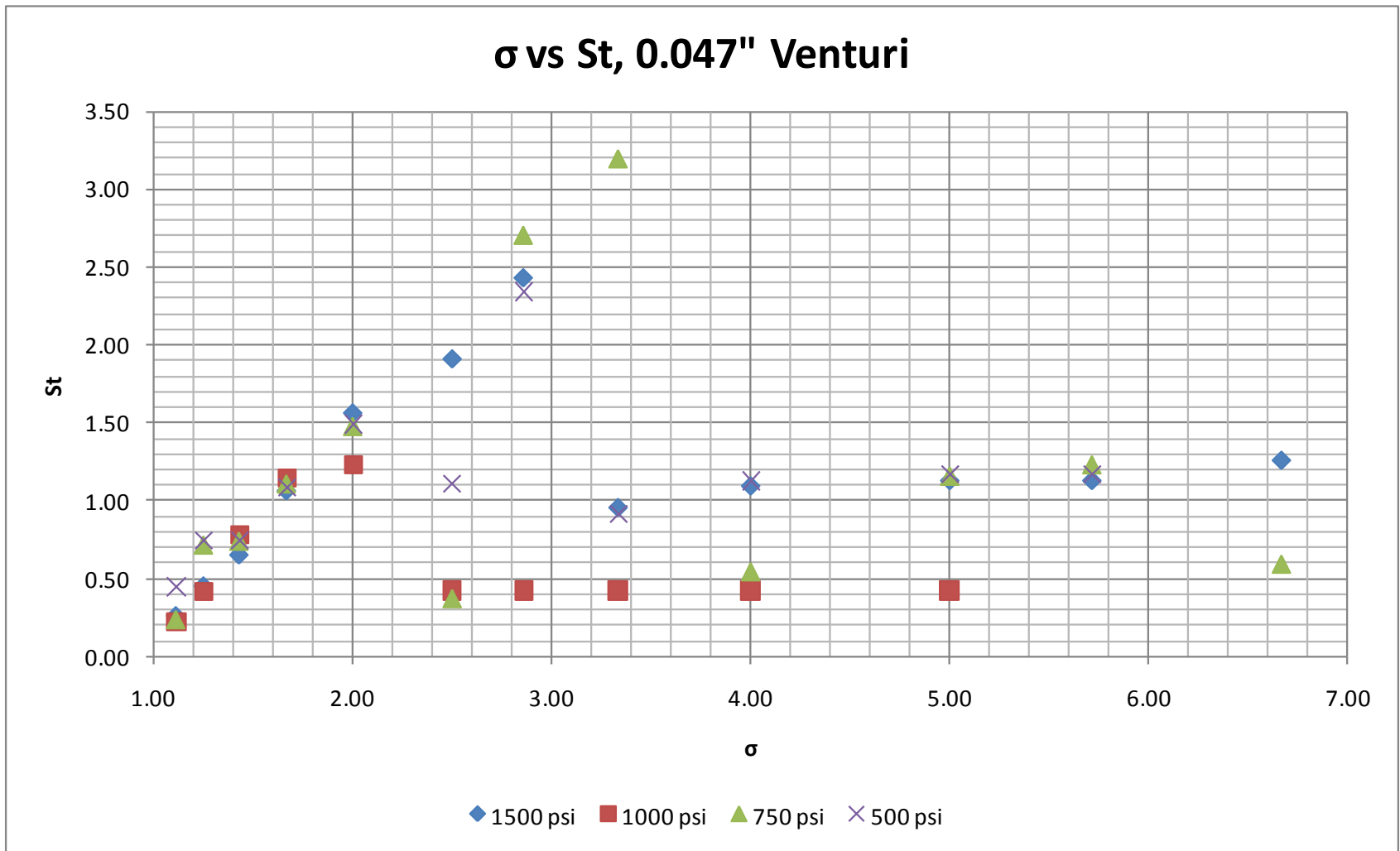

Fig28.
(Phuoc Hai Tran AFRL/RZSE, 2011)



Frequency Signature

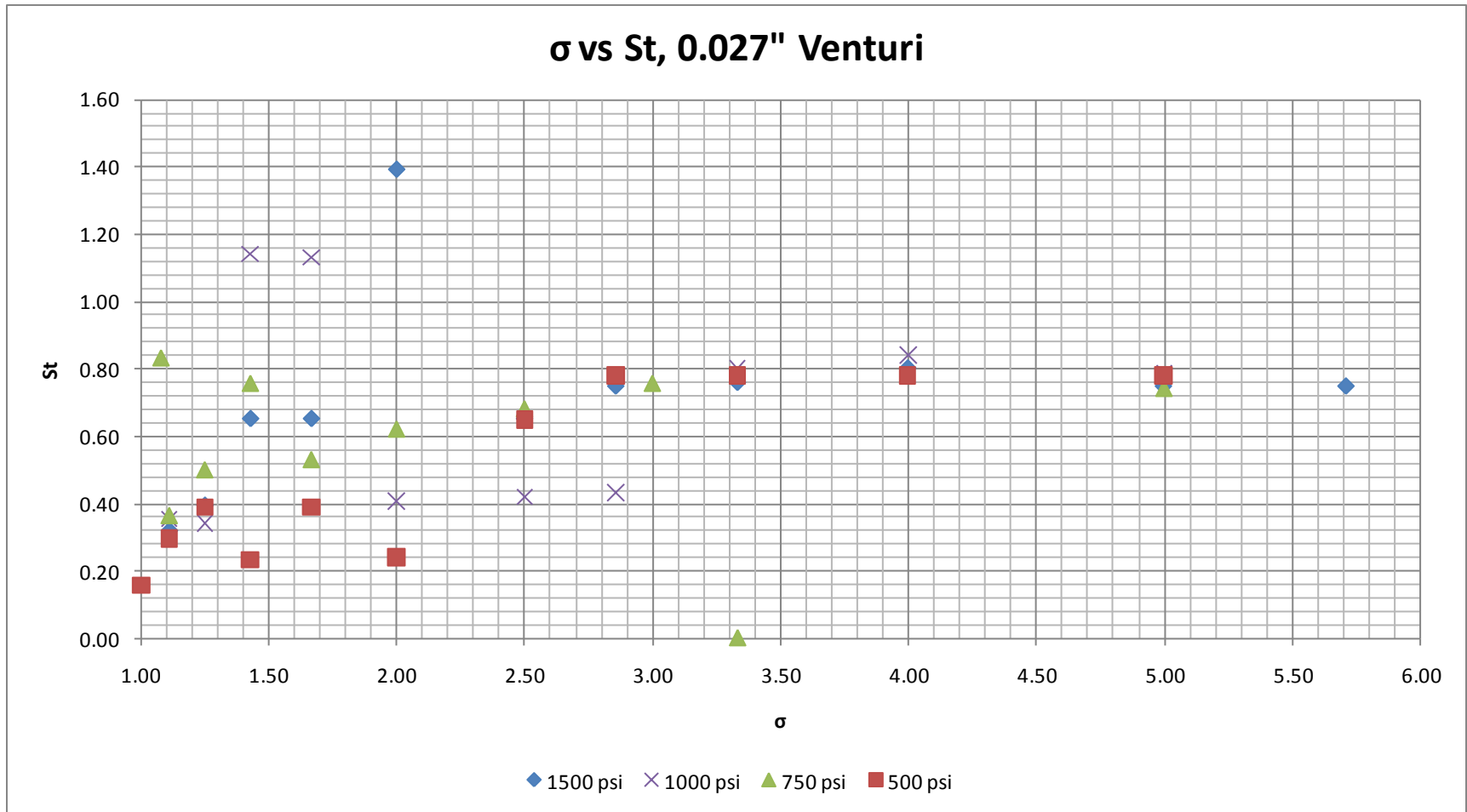

Fig29.
(Phuoc Hai Tran AFRL/RZSE, 2011)



Frequency Signature

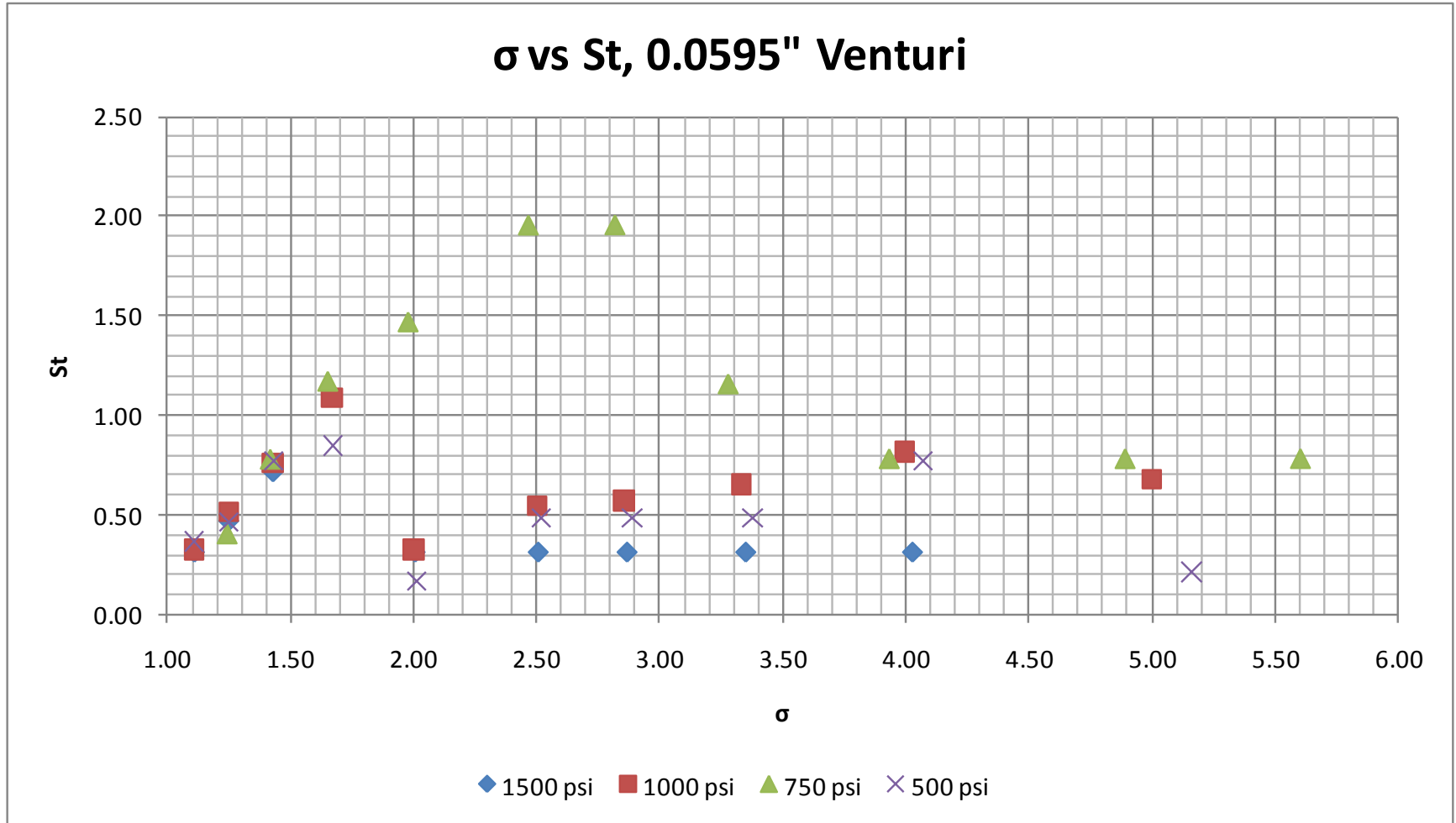

Fig30.
(Phuoc Hai Tran AFRL/RZSE, 2011)



Frequency Signature

σ vs St , Similar Mass Flow Rate

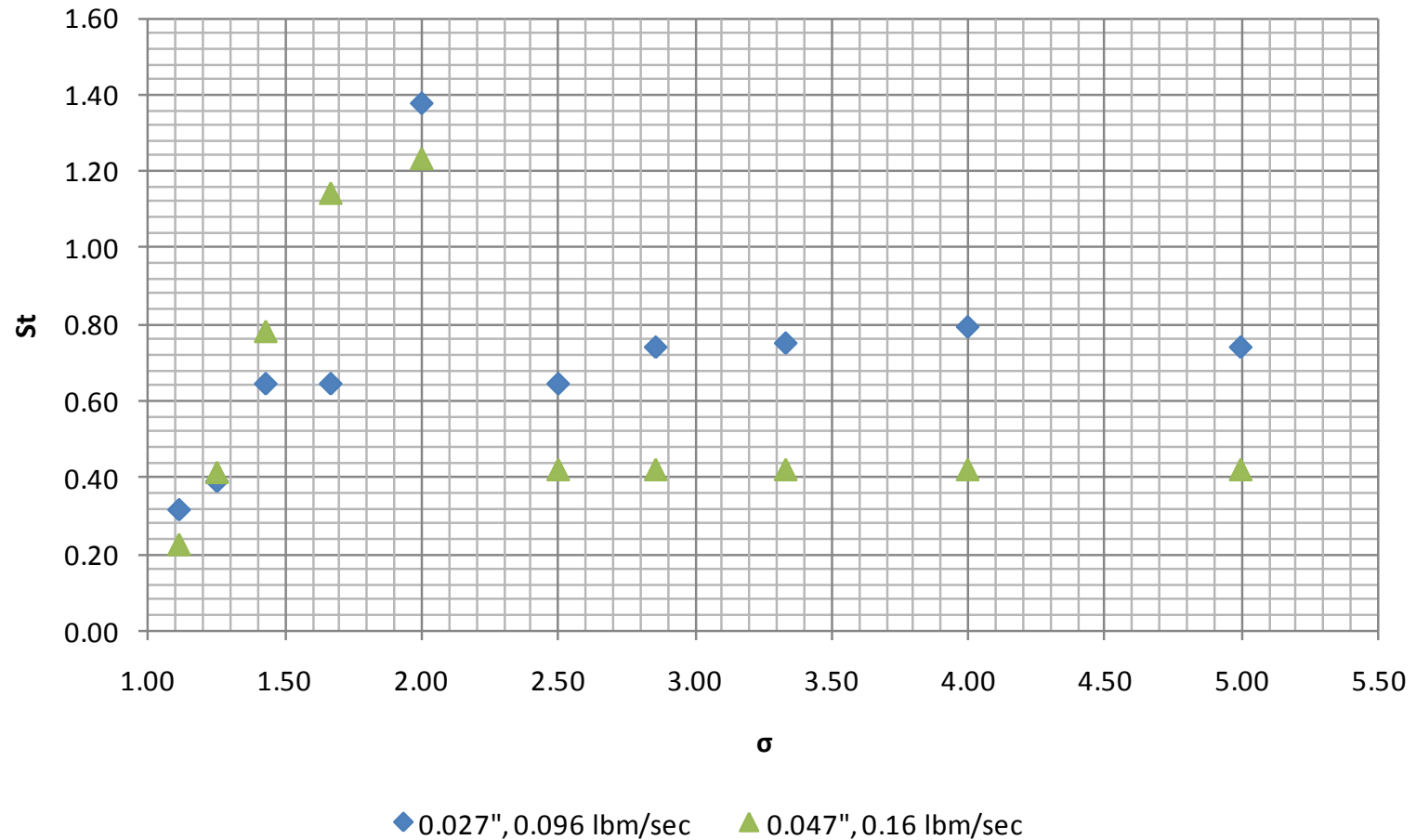

Fig31.

(Phuoc Hai Tran AFRL/RZSE, 2011)

Distribution A. Approved for public release; distribution unlimited



Frequency Signature

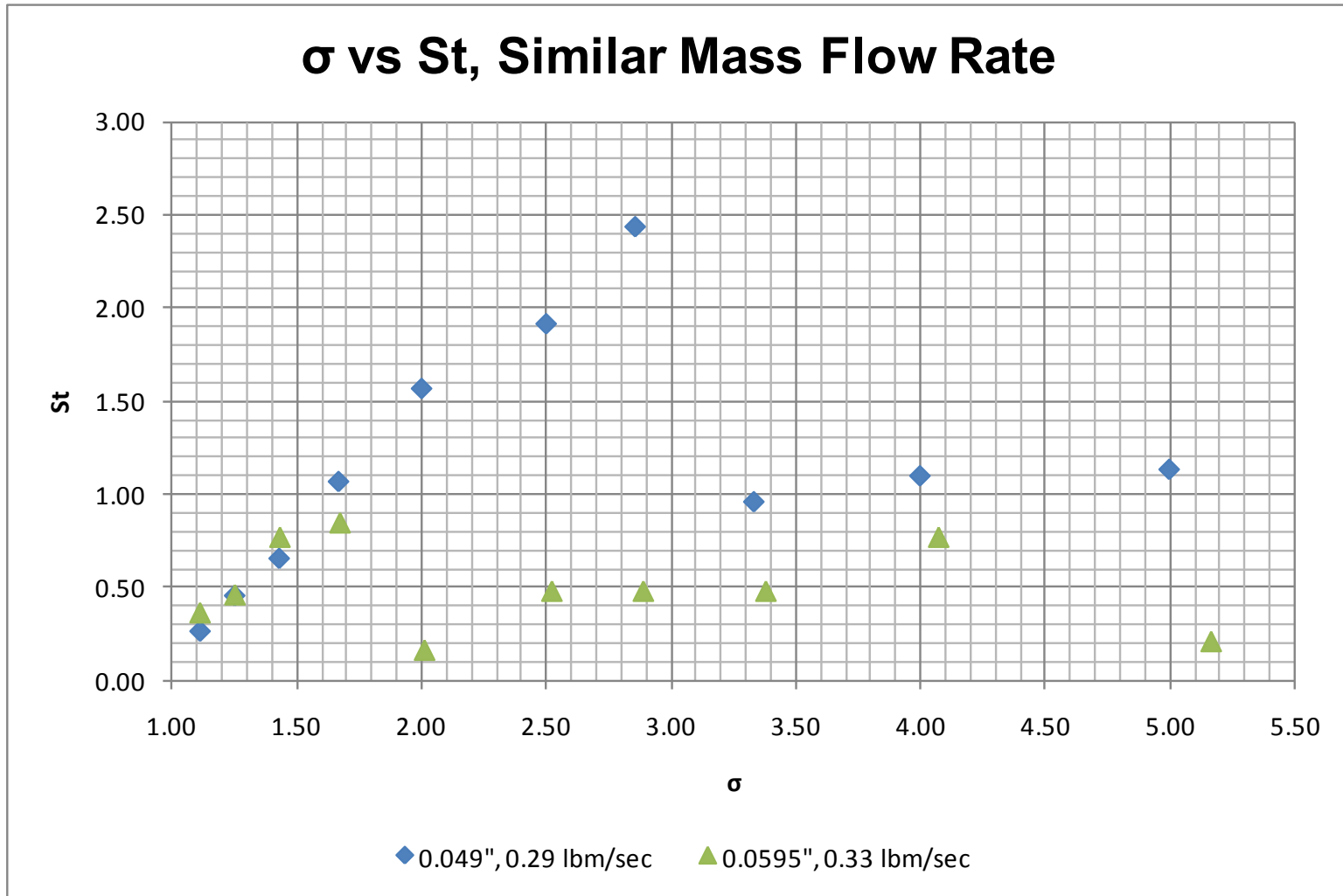

Fig32.
(Phuoc Hai Tran AFRL/RZSE, 2011)

Distribution A. Approved for public release; distribution unlimited



Conclusions

Distribution A. Approved for public release; distribution unlimited



Conclusions



- **Acoustic disturbances caused by cavitating venturi not well attenuated**
 - Only 4% decrease in pressure wave amplitude from near to far downstream stations at the most
- **Strouhal numbers found to be closer to 0.8 (or 0.4 depending on harmonic)**
- **Complex frequency signatures vary over the operating regime of a cavitating venturi**



Future Work



- **Explore selection of fundamental quantities and comparisons for Strouhal number**
- **Examine effect of venturi design**
- **More closely represent a real system**
- **Examine cause of complex frequency signatures, especially in the high range (10,000 – 20,000 Hz)**
- **Examine cause for anomalous C_d for 0.0595" Venturi**



Internship Experience Summary



Engage in professional research engineering

- **Logistics**

- How to interact with engineers, technicians, and industry for project completion
- How to prepare and present technical information

- **Research**

- How to effectively survey literature
- How to design, prepare, and conduct an experiment
- How to perform data analysis
 - Spectral Analysis and FFT Frequency Spectra



Questions?



Distribution A. Approved for public release; distribution unlimited



Upstream Effects

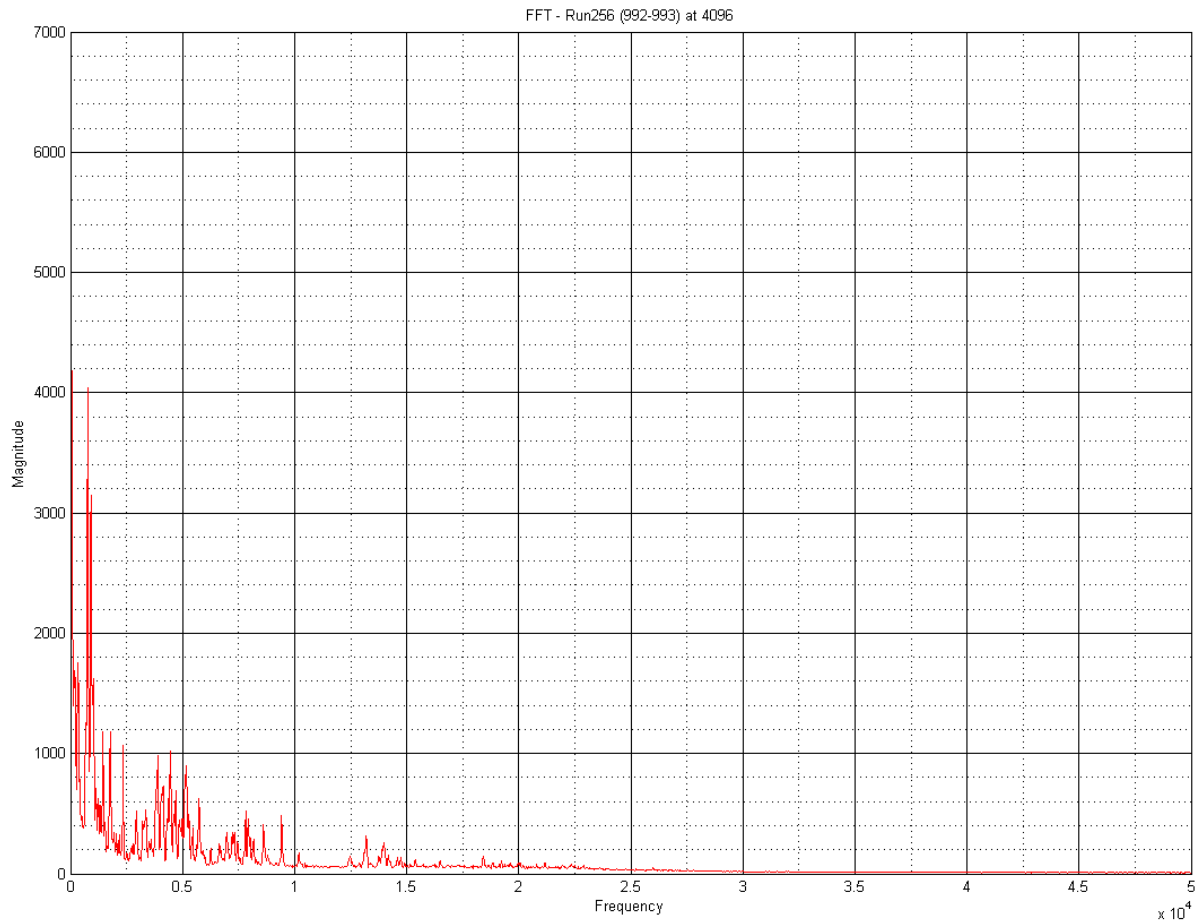

Distribution A. Approved for public release; distribution unlimited



Upstream Effects

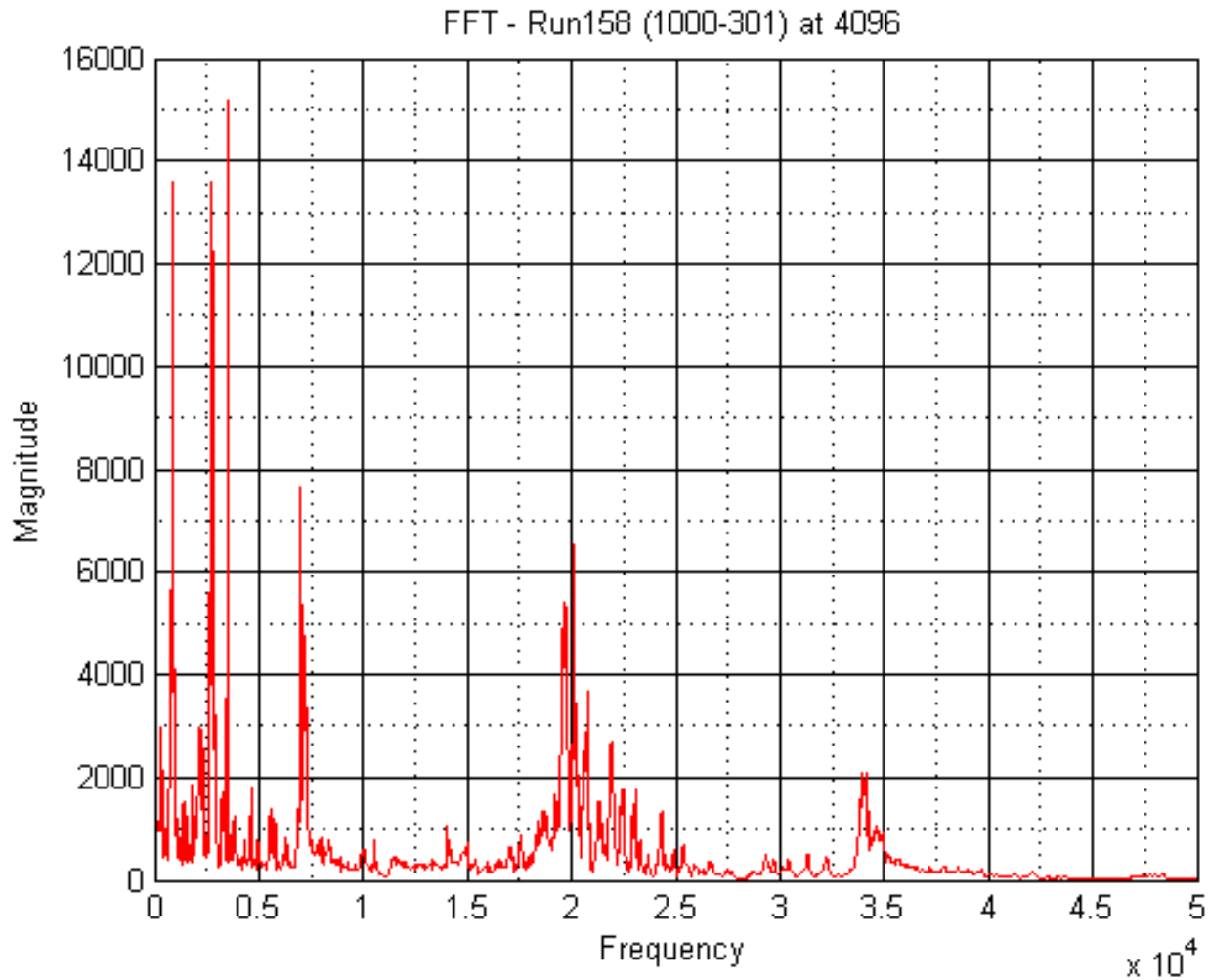

Distribution A. Approved for public release; distribution unlimited



Upstream Effects

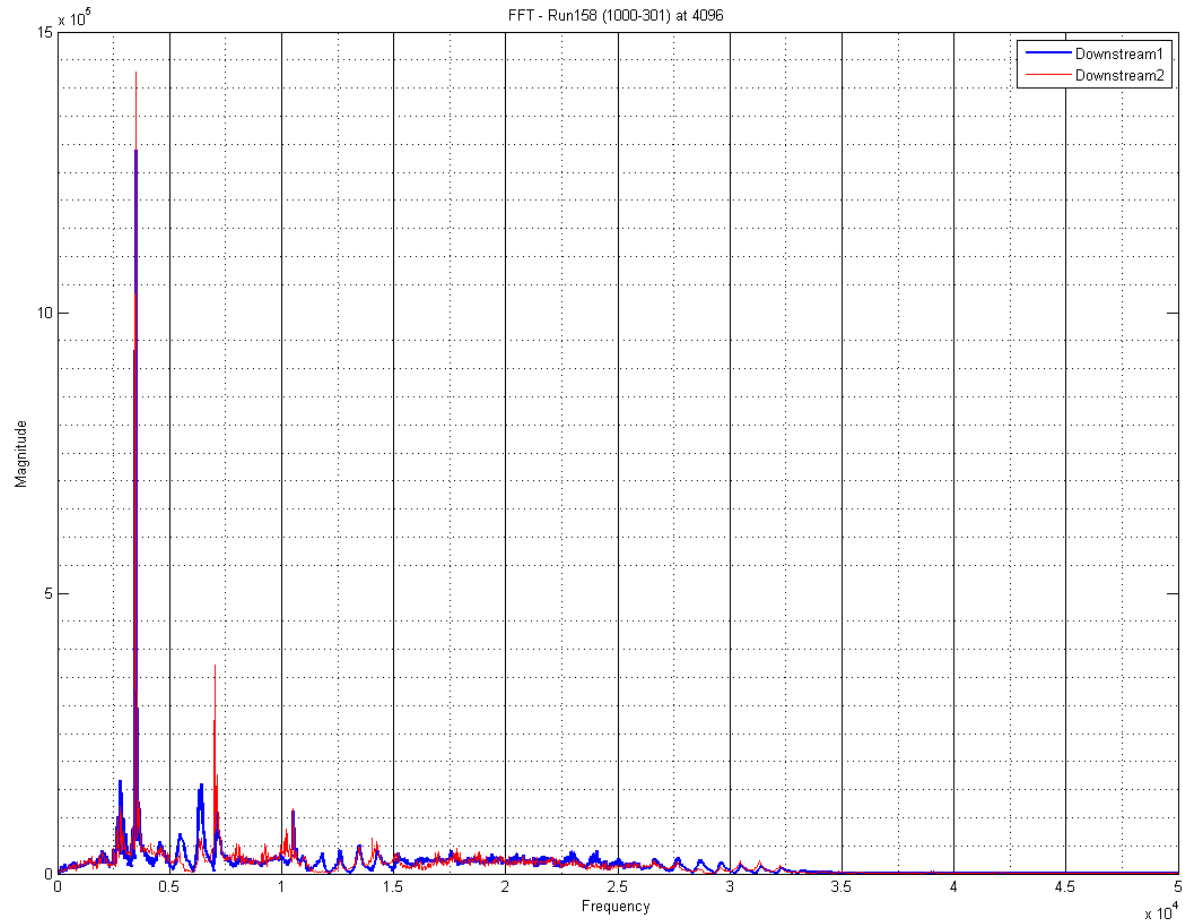

Distribution A. Approved for public release; distribution unlimited