

3070  
NACA TN 2704



# NATIONAL ADVISORY COMMITTEE FOR AERONAUTICS

TECHNICAL NOTE 2704

FATIGUE STRENGTHS OF 14S-T4 ALUMINUM ALLOY  
SUBJECTED TO BIAXIAL TENSILE STRESSES

By Joseph Marin and W. P. Hughes

The Pennsylvania State College



Washington

June 1952

AFMDC  
TECHNICAL LIBRARY  
AFL 2811

<b>REPORT DOCUMENTATION PAGE</b>			<i>Form Approved</i> <i>OMB No. 0704-0188</i>	
Public reporting burden for this collection of information is estimated to average 1 hour per response, including the time for reviewing instructions, searching existing data sources, gathering and maintaining the data needed, and completing and reviewing this collection of information. Send comments regarding this burden estimate or any other aspect of this collection of information, including suggestions for reducing this burden to Department of Defense, Washington Headquarters Services, Directorate for Information Operations and Reports (0704-0188), 1215 Jefferson Davis Highway, Suite 1204, Arlington, VA 22202-4302. Respondents should be aware that notwithstanding any other provision of law, no person shall be subject to any penalty for failing to comply with a collection of information if it does not display a currently valid OMB control number. <b>PLEASE DO NOT RETURN YOUR FORM TO THE ABOVE ADDRESS.</b>				
<b>1. REPORT DATE (DD-MM-YYYY)</b> June 1952		<b>2. REPORT TYPE</b> Technical note		<b>3. DATES COVERED (From - To)</b>
<b>4. TITLE AND SUBTITLE</b> Fatigue Strengths of 14S-T4 Aluminum Alloy Subjected to Biaxial Tensile Stresses			<b>5a. CONTRACT NUMBER</b>	
			<b>5b. GRANT NUMBER</b>	
			<b>5c. PROGRAM ELEMENT NUMBER</b>	
<b>6. AUTHOR(S)</b> Joseph Marin and W. P. Hughes			<b>5d. PROJECT NUMBER</b>	
			<b>5e. TASK NUMBER</b>	
			<b>5f. WORK UNIT NUMBER</b>	
<b>7. PERFORMING ORGANIZATION NAME(S) AND ADDRESS(ES)</b> Pennsylvania State University, State College, PA 16502			<b>8. PERFORMING ORGANIZATION REPORT NUMBER</b>	
<b>9. SPONSORING / MONITORING AGENCY NAME(S) AND ADDRESS(ES)</b> National Advisory Committee for Aeronautics			<b>10. SPONSOR/MONITOR'S ACRONYM(S)</b> NACA	
			<b>11. SPONSOR/MONITOR'S REPORT NUMBER(S)</b> TN-2704	
<b>12. DISTRIBUTION / AVAILABILITY STATEMENT</b> Approved for public release; distribution is unlimited.				
<b>13. SUPPLEMENTARY NOTES</b>				
<b>14. ABSTRACT</b> The purpose of this investigation was to determine the influence of biaxial tensile stresses on the fatigue strength of a 14S-T4 aluminum alloy when subjected to various ratios of biaxial stresses. The effect upon the fatigue strength of varying the ratio of the biaxial stresses was studied. The biaxial fatigue stresses were produced by applying simultaneously a pulsating internal pressure and a fluctuating axial tensile load to a thin-walled tubular specimen. The maximum and minimum values of the longitudinal and circumferential stresses were kept in phase by adjusting the testing machine. The dynamic loads were applied to the specimen by a specially designed testing machine. The fatigue strengths and S-N diagrams were obtained up to about 10 (exp 7) cycles for four principal stress ratios. The test results show that the fatigue strength is greatly affected by the anisotropy of the material. For this reason, it was found that the fatigue strength of the material in the circumferential direction was about two-thirds of the fatigue strength in the longitudinal direction. The test results for the 14S-T4 extruded tubing did not agree with any particular theory of failure. However, if the anisotropy of the material is considered the results are sufficiently close to the stress theory to permit its use in design.				
<b>15. SUBJECT TERMS</b>				
<b>16. SECURITY CLASSIFICATION OF:</b> Unclassified			<b>17. LIMITATION OF ABSTRACT</b> UU	<b>18. NUMBER OF PAGES</b> 25
<b>a. REPORT</b> U	<b>b. ABSTRACT</b> U	<b>c. THIS PAGE</b> U		
			<b>19b. TELEPHONE NUMBER (include area code)</b>	

## TECHNICAL NOTE 2704

## FATIGUE STRENGTHS OF 14S-T4 ALUMINUM ALLOY

## SUBJECTED TO BIAXIAL TENSILE STRESSES

By Joseph Marin and W. P. Hughes

## SUMMARY

The purpose of this investigation was to determine the influence of biaxial tensile stresses on the fatigue strength of a 14S-T4 aluminum alloy when subjected to various ratios of biaxial stresses. The effect upon the fatigue strength of varying the ratio of the biaxial stresses was studied. The biaxial fatigue stresses were produced by applying simultaneously a pulsating internal pressure and a fluctuating axial tensile load to a thin-walled tubular specimen. The maximum and minimum values of the longitudinal and circumferential stresses were kept in phase by adjusting the testing machine. The dynamic loads were applied to the specimen by a specially designed testing machine.

The fatigue strengths and S-N diagrams were obtained up to about  $10^7$  cycles for four principal stress ratios. The test results show that the fatigue strength is greatly affected by the anisotropy of the material. For this reason, it was found that the fatigue strength of the material in the circumferential direction was about two-thirds of the fatigue strength in the longitudinal direction. The test results for the 14S-T4 extruded tubing did not agree with any particular theory of failure. However, if the anisotropy of the material is considered the results are sufficiently close to the stress theory to permit its use in design.

## INTRODUCTION

Most fatigue tests are conducted with specimens subjected to simple stresses, such as fluctuating axial or fluctuating bending stresses. There are many machine and structural parts, however, in which the stresses are biaxial or triaxial and act in more than one direction. A survey of the available test data (references 1 to 5) shows that there is very little information on the fatigue strength of metals subjected to combined stresses. The purpose of this investigation was to obtain the fatigue strength of a 14S-T4 aluminum alloy when subjected to tensile biaxial fatigue stresses. Various ratios of fluctuating biaxial tensile

stresses were produced by subjecting a tubular specimen to fluctuating axial tension and fluctuating internal pressure.

This investigation was conducted at the School of Engineering of The Pennsylvania State College under the sponsorship and with the financial assistance of the National Advisory Committee for Aeronautics. The tests were conducted in the Fatigue Laboratory of the Department of Engineering Mechanics. Mr. W. P. Hughes, research assistant, conducted most of the tests and computed the test data. Messrs. L. W. Hu and J. D. Cuzzolina assisted in the test program. The administrative direction given by the NACA and the School of Engineering and the technical assistance given by the foregoing individuals are greatly appreciated.

#### SYMBOLS

A	cross-sectional area of tubular specimen, square inches
d	internal diameter of specimen, inches
N	number of cycles to failure
p	internal pressure, psi
P	axial tensile load, pounds
$p', p'', p'''$	maximum, mean, and minimum fluctuating pressures, respectively, psi
$P', P'', P'''$	maximum, mean, and minimum fluctuating axial tension loads, respectively, pounds
R	principal stress ratio
t	wall thickness of specimen
$\sigma_1, \sigma_2$	longitudinal and transverse biaxial principal stresses, psi
$\sigma_1', \sigma_1'', \sigma_1'''$	maximum, mean, and minimum values of principal stress $\sigma_1$ , respectively, psi
$\sigma_2', \sigma_2'', \sigma_2'''$	maximum, mean, and minimum values of principal stress $\sigma_2$ , respectively, psi
$\sigma_{1t}'$	fatigue strength for uniaxial longitudinal tension, psi

## DESCRIPTION OF MATERIAL

The material tested in this investigation was a fully heat-treated aluminum alloy designated as 14S-T4. The material was hot-rolled and was received in tubular form, in lengths of 7 inches, with an outside diameter of  $1\frac{5}{8}$  inches and a wall thickness of  $1/4$  inch. The nominal chemical composition, in addition to aluminum and normal impurities, consists of 4.4 percent copper, 0.8 percent each of silicon and manganese, and 0.4 percent magnesium. The mechanical properties of the material in tension for different orientations, as supplied by the Aluminum Company of America, are given in table 1.

## TEST PROCEDURE

Test specimen.- The test specimens were machined from extruded tubing. They had an over-all length of 7 inches, with an intermediate length of about 4 inches of reduced wall thickness of 0.05 inch. The remaining dimensions of the specimen are given in figure 1. In finishing the specimen surfaces, both the inner and outer surfaces were polished with a 9/0 metallurgical abrasive paper.

The wall thickness of the specimens was measured to 0.0001 inch using the apparatus described in reference 6. The ratio of the wall thickness to the inside diameter was 0.050 so that the circumferential stresses throughout the wall were essentially uniform and the values of these stresses could be approximately determined assuming a thin wall and uniform stress.

Considering the specimens to be thin-walled tubes subjected to an axial tensile load  $P$  and an internal pressure  $p$ , the longitudinal and circumferential stresses are, respectively,

$$\begin{aligned}\sigma_1 &= \frac{P}{A} + \frac{pd}{4t} \\ &= \frac{P}{\pi dt} + \frac{pd}{4t}\end{aligned}\tag{1}$$

and

$$\sigma_2 = \frac{pd}{2t}$$

where

A                    cross-sectional area of tube  
 d                    internal diameter of specimen  
 t                    wall thickness of specimen

The tubular specimens were subjected to synchronous variable loads  $P$  and  $p$  with maximum values  $P'$  and  $p'$ , minimum values  $P'''$  and  $p'''$ , and mean values  $P''$  and  $p''$ . Using equations (1) and (2) the maximum, minimum, and mean values of the principal stresses  $\sigma_1$  and  $\sigma_2$  are

$$\left. \begin{aligned} \sigma_1' &= \frac{P'}{\pi dt} + \frac{p'd}{4t} \\ \sigma_1''' &= \frac{P'''}{\pi dt} + \frac{p'''d}{4t} \\ \sigma_1'' &= \frac{P''}{\pi dt} + \frac{p''d}{4t} \end{aligned} \right\} \quad (3)$$

$$\left. \begin{aligned} \sigma_2' &= \frac{p'd}{2t} \\ \sigma_2''' &= \frac{p'''d}{2t} \\ \sigma_2'' &= \frac{p''d}{2t} \end{aligned} \right\} \quad (4)$$

For fluctuating stresses as defined by equations (3) and (4), the fatigue strengths of the material will depend upon the ratio of the minimum to the maximum stresses as well as the ratio of the principal stresses. It is apparent that a large number of tests would be required to consider all possible stress combinations. For this reason, it was necessary to restrict the test program to a consideration of the influence on the fatigue strength of the principal stress ratio  $\sigma_2'/\sigma_1'$  for a given ratio of the minimum to the maximum stresses. The ratio of the minimum to the maximum stress was maintained to a value less than 0.10 for all tests.

Testing machine.- A special testing machine, as described in reference 4, was used for these tests. Figure 2 is a photograph of this machine. The tubular specimens S are subjected to a fluctuating axial load by the lever K. This lever is subjected to a fluctuating load by means of an eccentric  $E_1$ . The eccentric  $E_1$  is attached to a gear which is driven by a pinion. The pinion is operated by a 3-horsepower, 3600-rpm, alternating-current motor T. By means of a gear reduction of 1 to 10, stress fluctuations of about 300 cycles per minute are produced on the specimen. It was necessary to have such a low rate of stress fluctuation in order to eliminate errors due to interference of pressure waves introduced by the successive application of internal pressure.

A Bosch pump applies the fluctuating internal oil pressure. The pump is activated by a plunger and connecting-rod system attached to a driving eccentric  $E_2$ . A change in the throw of the eccentric changes the internal pressure produced in the specimen. An accumulator A is used to provide against drop in pressure caused by possible oil leakage. The number of stress fluctuations to fracture is recorded by a revolution counter U. The motor is stopped by a microswitch D when the loads are such as to produce a circumferential crack. The microswitch operates or stops the motor when the rotation of the yoke Y occurs as a circumferential crack is produced. For tests in which failure results by longitudinal cracks or internal pressure, the motor is also stopped by the microswitch D. This is accomplished when the fracture of the specimen releases oil into a delicately balanced container M. The released oil unbalances the container and trips the microswitch.

The axial load is measured by a 10,000-pound dynamometer N which is connected between the eccentric  $E_1$  and the lever K. The lever with a 4-to-1 lever-arm ratio applies the load to the specimens S mounted between spherical seats. The Bourdon gages H and L measure, respectively, the maximum and minimum internal pressures. Specially designed check valves at G prevent fluctuations of the pressure-gage pointers. Calibrations of the dynamometer and pressure gages were made periodically to insure accuracy of load measurement. Concentricity of axial loading was also checked by measuring the longitudinal strain on the specimen at four points equally spaced around the circumference. After adjustment, the maximum difference in stress around the circumference was found to be about 1 percent.

A Hathaway Type S-14A oscillograph (fig. 3) was used to measure the dynamic strain on the specimen using SR-4 gages. The stress calculated from these strains for each specimen tested was found to agree within 1 percent with the values calculated from the applied loads and specimen dimensions.

Method of testing.- The method of testing will be outlined for specimens subjected to both axial loading and internal pressure since for the tests with only one loading the procedure is simplified by the omission of certain adjustments.

The test procedure consists in first measuring the external diameter and wall thickness of the specimen at various locations on the specimen. Circumferential and longitudinal SR-4 dynamic strain gages are then cemented to the specimens. Two specimens are then screwed into the holders and the oil-pressure line is fastened to the connection in the center holder. The axial load corresponding to a selected value can be applied by adjusting the eccentric  $E_1$  to a given position and fixing that position with self-locking setscrews. Placing the eccentric  $E_1$  in its lowest position, a threaded turnbuckle above the dynamometer  $N$  is adjusted until the dynamometer reads the desired minimum load. The drive shaft can be rotated by hand to determine the maximum axial dynamometer load reading. If the load reading is not that desired, the above procedure is repeated until the desired reading is obtained.

For the internal pressure, the eccentric  $E_2$  is adjusted. This is done by first using a tentative setting of the outer eccentric relative to the inner. Then by the hand pump  $B$ , the internal-pressure system is filled with oil - the air being expelled from the air outlet in the upper specimen holder. The air outlet is closed when the system is filled with oil. The operation of the hand pump is then continued until the desired minimum internal pressure is reached with the piston of the Bosch pump at the bottom of its stroke. The drive shaft is then rotated by hand to obtain approximate readings of the maximum and minimum pressures. The foregoing static pressures will be slightly lower than the operating pressures. During the starting period the valve  $F$  to the pressure gages is closed to avoid shock loading. However, the valve  $F$  is left open during a test. Damage to the gage parts by fatigue is prevented by a specially designed valve block  $G$ , which permits static readings of the maximum pressure on gage  $H$  and the minimum pressure on gage  $L$ .

Synchronism of the axial load and internal pressure so that they will be in phase is made possible by the rotation of the inner part of eccentric  $E_2$  relative to the inner part of eccentric  $E_1$ . This inphase adjustment is made so that the minimum dynamometer reading is obtained when the pump piston is at the bottom of its stroke. This static adjustment was found to give synchronous loading conditions during the dynamic test loading. Photographic records with the Hathaway oscillograph were obtained to verify that the maximum and minimum values of the lateral and longitudinal strains occurred simultaneously.

The application of the internal pressure produced an elongation of the specimen which therefore requires that the axial load be adjusted. Further load adjustments and addition of oil by the hand pump may also be necessary during a test. Upon the fracture of a specimen the micro-switch shuts off the motor and the number of cycles to failure is recorded by the counter U. The fractured specimen is then replaced by a dummy specimen and the test is continued until the second specimen fails. The foregoing test procedure is repeated for pairs of specimens at different stress levels and for various principal stress ratios.

### TEST RESULTS

Fatigue strengths were obtained in this investigation for four principal stress ratios and for ratios of the minimum to the maximum stress equal to approximately 0. The strength values were determined for stress applications up to about  $5 \times 10^6$  cycles. Figure 4 gives the S-N curves for the four principal stress ratios  $R = \sigma_2'/\sigma_1' = 0, 1, 2,$  and 0.5. The data used in plotting figure 4 are shown in tables 2 to 5. Because of the slow speed of testing (about 300 cpm), it was necessary to limit the duration of the tests. The available time did not permit the determination of a statistically accurate S-N diagram. It did provide, however, the information to show the influence of tensile biaxial stresses upon the fatigue strength.

### ANALYSIS AND DISCUSSION

The effect of the principal stress ratio of the fatigue strength is shown in figure 5, which is a single plot of the S-N curves of figure 4. From figure 5 it is seen that the fatigue strengths for the various principal stress ratios are slightly lower than for longitudinal tension. The reduced strength under biaxial tension may be explained by the fact that the material has directional properties. It was found in another investigation (reference 7) that the tensile ultimate strength in the circumferential direction was 88 percent of that in the longitudinal direction. The influence of the direction properties of the material tested is also shown in figure 6, which compares the biaxial fatigue strengths with the longitudinal uniaxial fatigue strengths. A comparison was made between the test results and existing theories of failure but available theories were found inadequate. This difficulty may be due mainly to the fact that the material had directional properties. Figure 4 shows that the uniaxial fatigue strength in the lateral direction may be about 65 percent of the uniaxial fatigue strength in the longitudinal direction. If this anisotropy of the material is considered,

figure 5 shows that the stress theory may be considered to agree approximately with the test results.

Photographs of typical fractured specimens are shown in figure 7. For stress ratios of 0 and 0.5, the fracture was circumferential. The plane of fracture was about  $45^{\circ}$  to the surface of the tube. For stress ratios of 1 and 2, failure consisted of almost imperceptible longitudinal cracks varying from about  $1/4$  to 1 inch in length.

#### CONCLUSIONS

From an investigation of the fatigue strengths of a 14S-T4 aluminum alloy subjected to biaxial tensile stresses it was found that:

1. The fatigue strength was greatly affected by the anisotropy of the material. The fatigue strength in the circumferential direction for the extruded tubes was found to be about two-thirds of the fatigue strength in the longitudinal direction. This directional effect was also found to be greater for fatigue strengths than for static strengths.
2. Although no particular theory was found to agree with the test results, when anisotropy is considered the influence of the principal stress ratios may be approximately predicted by the stress theory.

The Pennsylvania State College  
State College, Pa., July 27, 1951

## REFERENCES

1. Marin, J.: Mechanical Properties of Materials and Design. McGraw-Hill Book Co., Inc., 1942. (See also, Marin, J.: Interpretation of Experiments on Fatigue Strength of Metals Subjected to Combined Stresses. The Welding Jour., vol. VII, no. 5, May 1942, pp. 245-s - 248-s.)
2. Morikawa, G. K., and Griffis, L.: The Biaxial Fatigue Strength of Low-Carbon Steels. The Welding Jour., vol. 24, March 1945, pp. 167-s - 174-s.
3. Sauer, J. A.: A Study of Fatigue Phenomena under Combined Stress. Vol. 4. Proc. Seventh Int. Cong. Appl. Mech. (Sept. 1948, London), 1948, pp. 150-164.
4. Marin, Joseph, and Shelton, William: Biaxial Fatigue Strength of 24S-T Aluminum Alloy. NACA TN 1889, 1949.
5. Majors, H., Jr., Mills, B. D., Jr., and MacGregor, C. W.: Fatigue under Combined Pulsating Stresses. Jour. Appl. Mech., vol. 16, no. 3, Sept. 1949, pp. 269-276.
6. Marin, Joseph, Faupel, J. H., Dutton, V. L., and Brossman, M. W.: Biaxial Plastic Stress-Strain Relations for 24S-T Aluminum Alloy. NACA TN 1536, 1948.
7. Marin, J., and Hu, L. W.: Plastic Stress-Strain Relations under Constant and Variable Biaxial Tension Stress Ratios for a 14S-T4 Aluminum Alloy. Contract NAW-5791, NACA and The Penn. State College, March 1951.

TABLE 1

## MECHANICAL PROPERTIES IN TENSION FOR 14S HOT-ROLLED BARS

1  $\frac{5}{8}$  -in. diam., bored with 3/4-in. hole and heat-treated

Specimen (b)	Tensile strength (psi) (a)				Yield strength (psi) (a)				Elongation in 4 diam (percent) (a)			
	L	D	T <sub>1</sub>	T <sub>2</sub>	L	D	T <sub>1</sub>	T <sub>2</sub>	L	D	T <sub>1</sub>	T <sub>2</sub>
460501-T6-6-1	69,000	71,000	66,300	67,700	61,200	62,700	60,800	61,400	12	8	6.5	8.8
460501-T6-6-2	69,500	71,000	67,400	66,200	61,200	63,200	62,400	60,300	12	10	6.5	6.8
460501-T6-6-3	68,900	75,000	68,000	68,800	60,700	67,700	62,900	63,800	12	10	6.0	<sup>c</sup> 2.8
Average	69,130	72,330	67,230	67,570	61,030	64,530	62,330	61,830	12	9.3	6.3	6.1
460501-T4-4-1	60,100	63,700	60,600	61,800	32,100	36,800	40,200	40,800	26	20	18.8	15.6
460501-T4-4-2	58,900	63,900	62,700	63,500	31,700	35,800	39,300	38,800	28	22	20.4	18.9
460501-T4-4-3	59,600	61,300	61,100	60,400	31,300	33,600	37,700	37,600	26	24	18.6	18.7
Average	59,530	62,970	61,470	61,900	31,700	35,400	39,070	39,070	26.7	22	19.3	17.7

<sup>a</sup>L, longitudinal specimen; D, specimen taken diagonal to longitudinal and transverse directions; T<sub>1</sub>, transverse specimen; T<sub>2</sub>, transverse specimen at 90° to T<sub>1</sub>.

<sup>b</sup>First three specimens heat-treated to -T6 temper; last three, to -T4 temper.

<sup>c</sup>Specimen failed outside of gage marks.



TABLE 2

FATIGUE TEST DATA FOR STRESS RATIO  $R = \sigma_2' / \sigma_1' = 0$ 

Specimen	$P'$ (lb)	$P'''$ (lb)	d (in.)	t (in.)	$\sigma_1'$ (psi)	$\sigma_2'$ (psi)	$\sigma_1'''$ (psi)	$\sigma_2'''$ (psi)	R	Number of cycles
B58	$7.03 \times 10^3$	$0.18 \times 10^3$	1.00	0.0504	$42.1 \times 10^3$	0	$1.0 \times 10^3$	0	0	$0.0336 \times 10^6$
B57	8.58	.19	1.00	.0510	42.0	0	1.0	0	0	.0285
B56	7.10	.18	1.00	.0506	42.4	0	1.0	0	0	.1535
B35	6.54	.17	1.00	.0500	39.6	0	1.0	0	0	.0269
B36	6.55	.18	1.00	.0504	39.4	0	1.0	0	0	.1323
B22	6.00	.40	1.00	.0503	36.4	0	2.4	0	0	.1549
B23	5.90	.40	1.00	.0512	35.2	0	2.3	0	0	.2869
B7	5.80	.40	1.00	.0498	35.2	0	2.4	0	0	.5580
B27	5.21	.28	1.00	.0510	31.0	0	1.7	0	0	.9969
B25	5.11	.33	1.00	.0498	31.0	0	2.0	0	0	1.7342
B42	4.60	.17	1.00	.0496	28.0	0	1.0	0	0	5.1040

TABLE 3

FATIGUE TEST DATA FOR STRESS RATIO  $R = \sigma_2'/\sigma_1' = 2.0$ 

Specimen	$p'$ (psi)	$p'''$ (psi)	d (in.)	t (in.)	$\sigma_1'$ (psi)	$\sigma_2'$ (psi)	$\sigma_1'''$ (psi)	$\sigma_2'''$ (psi)	R	Number of cycles
B75	$3.70 \times 10^3$	$0.200 \times 10^3$	1.00	0.0508	$18.20 \times 10^3$	$36.40 \times 10^3$	$0.98 \times 10^3$	$1.96 \times 10^3$	2.0	$0.0452 \times 10^6$
B76	3.70	.200	1.00	.0508	18.20	36.40	.98	1.96	2.0	.0551
B63	3.10	.175	1.00	.0505	15.35	30.70	.86	1.73	2.0	.1030
B64	3.10	.175	1.00	.0512	15.20	30.40	.86	1.72	2.0	.1749
B65	2.60	.175	1.00	.0509	12.80	25.60	.86	1.72	2.0	.1689
B72	2.60	.175	1.00	.0504	12.90	25.80	.86	1.73	2.0	.1934
B73	2.20	.175	1.00	.0514	10.70	21.40	.85	1.70	2.0	.2666
B74	2.20	.175	1.00	.0510	10.80	21.60	.86	1.72	2.0	1.3511
B84	1.80	.175	1.00	.0507	8.87	17.75	.86	1.73	2.0	5.0992
B85	1.80	.175	1.00	.0504	8.95	17.90	.87	1.74	2.0	5.0992
B86	4.10	.150	1.00	.0508	20.20	40.40	.74	1.47	2.0	.0199
B87	4.10	.150	1.00	.0505	20.30	40.60	.74	1.48	2.0	.0245

NACA

TABLE 4

FATIGUE TEST DATA FOR STRESS RATIO  $R = \sigma_2' / \sigma_1' = 1.0$

Specimen	$P'$ (lb)	$P'''$ (lb)	$p'$ (psi)	$p'''$ (psi)	d (in.)	t (in.)	$\sigma_1'$ (psi)	$\sigma_2'$ (psi)	$\sigma_1'''$ (psi)	$\sigma_2'''$ (psi)	R	Number of cycles
B115	$3.30 \times 10^3$	$0.40 \times 10^3$	$4.00 \times 10^3$	$0.175 \times 10^3$	1.00	0.0502	$39.90 \times 10^3$	$40.00 \times 10^3$	$3.30 \times 10^3$	$1.75 \times 10^3$	1.00	$0.0211 \times 10^6$
B98	2.88	.40	3.50	.175	1.00	.0509	34.90	34.40	3.20	1.74	.99	.0722
B99	2.88	.40	3.50	.175	1.00	.0512	34.70	34.20	3.10	1.73	.99	.0903
B100	2.47	.40	3.00	.175	1.00	.0505	29.70	29.70	3.20	1.74	1.00	.2156
B116	2.06	.40	2.50	.150	1.00	.0509	24.56	24.60	3.10	1.50	1.00	5.0310
B131	2.31	.40	2.80	.150	1.00	.0511	27.51	27.40	3.10	1.96	.99	3.3200
B132	2.47	.40	3.00	.200	1.00	.0510	29.52	29.40	3.10	1.96	.99	.6796



TABLE 5

FATIGUE TEST DATA FOR STRESS RATIO  $R = \sigma_2'/\sigma_1' = 0.5$ 

Specimen	P' (lb)	P''' (lb)	p' (psi)	p''' (psi)	d (in.)	t (in.)	$\sigma_1'$ (psi)	$\sigma_2'$ (psi)	$\sigma_1'''$ (psi)	$\sigma_2'''$ (psi)	R	Number of cycles
B187	5650	400	2400	200	1.00	0.0512	$46.8 \times 10^3$	$23.40 \times 10^3$	$3.44 \times 10^3$	$1.95 \times 10^3$	0.50	$0.0570 \times 10^6$
B186	5300	400	2250	200	1.00	.0498	45.2	22.60	3.56	2.01	.50	.0643
B157	5200	400	2100	200	1.00	.0503	43.4	20.90	3.53	1.99	.48	.1079
B139	4960	400	2000	175	1.00	.0514	40.4	19.46	3.33	1.70	.48	.1816
B140	4450	400	1800	200	1.00	.0509	36.7	17.68	3.48	1.96	.48	.3104
B158	3960	400	1600	200	1.00	.0507	32.8	15.78	3.50	1.97	.48	.4133
B190	3650	400	1550	200	1.00	.0516	30.0	15.02	3.44	1.94	.50	5.2640
B167	3530	400	1500	200	1.00	.0508	29.5	14.76	3.49	1.97	.50	5.0408

NACA

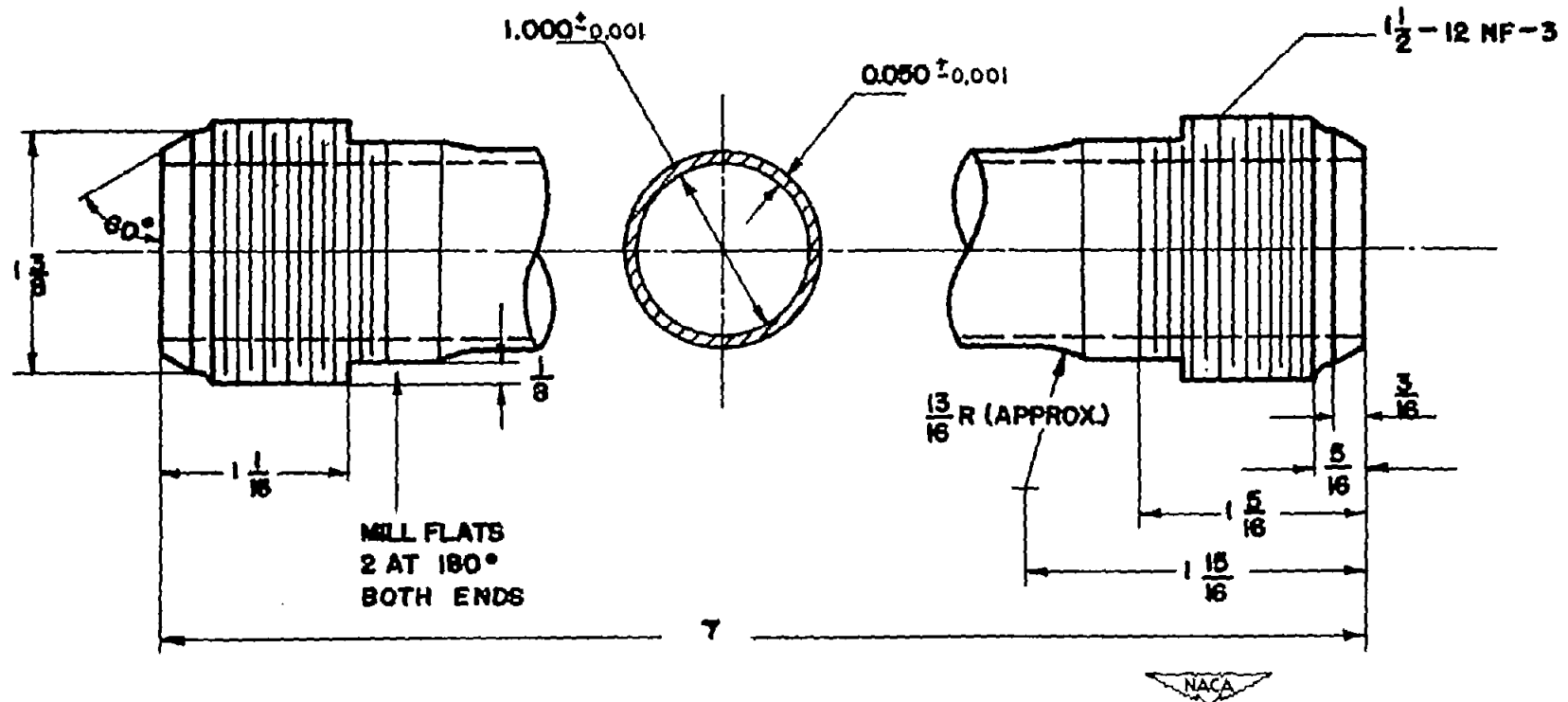

Figure 1.- Biaxial stress specimen. All dimensions are in inches.  
 Inner and outer surfaces of tube must be polished smooth with  
 9/0 Metalite cloth.

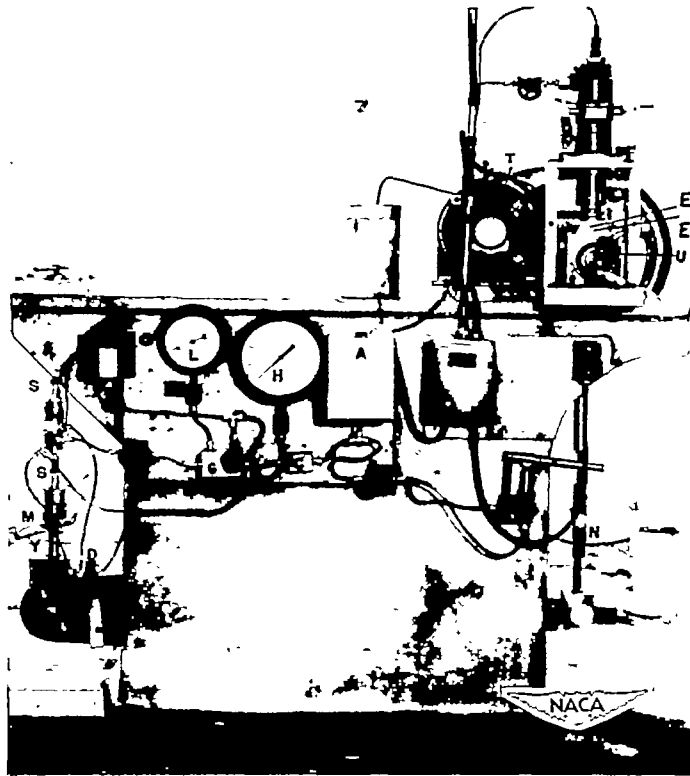

Figure 2.- Biaxial fatigue testing machine.

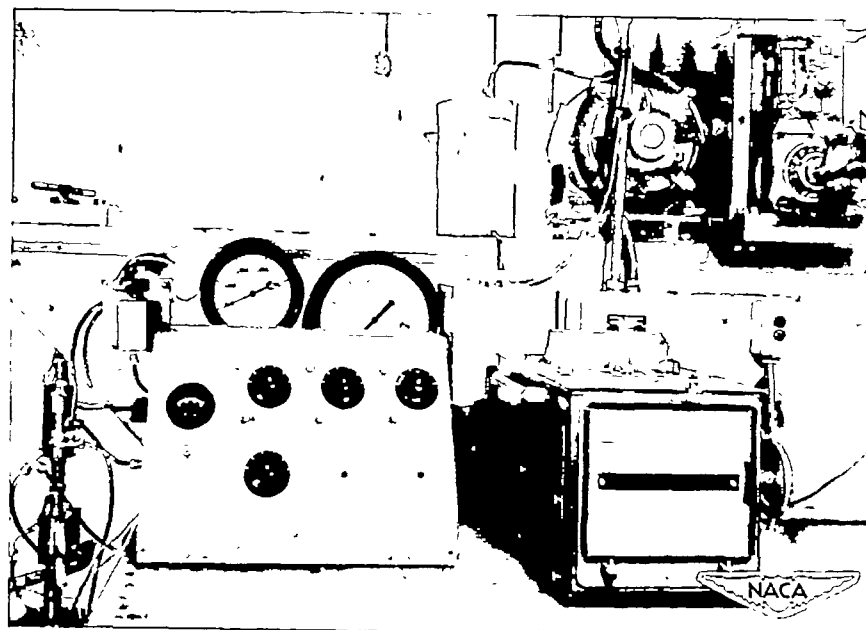
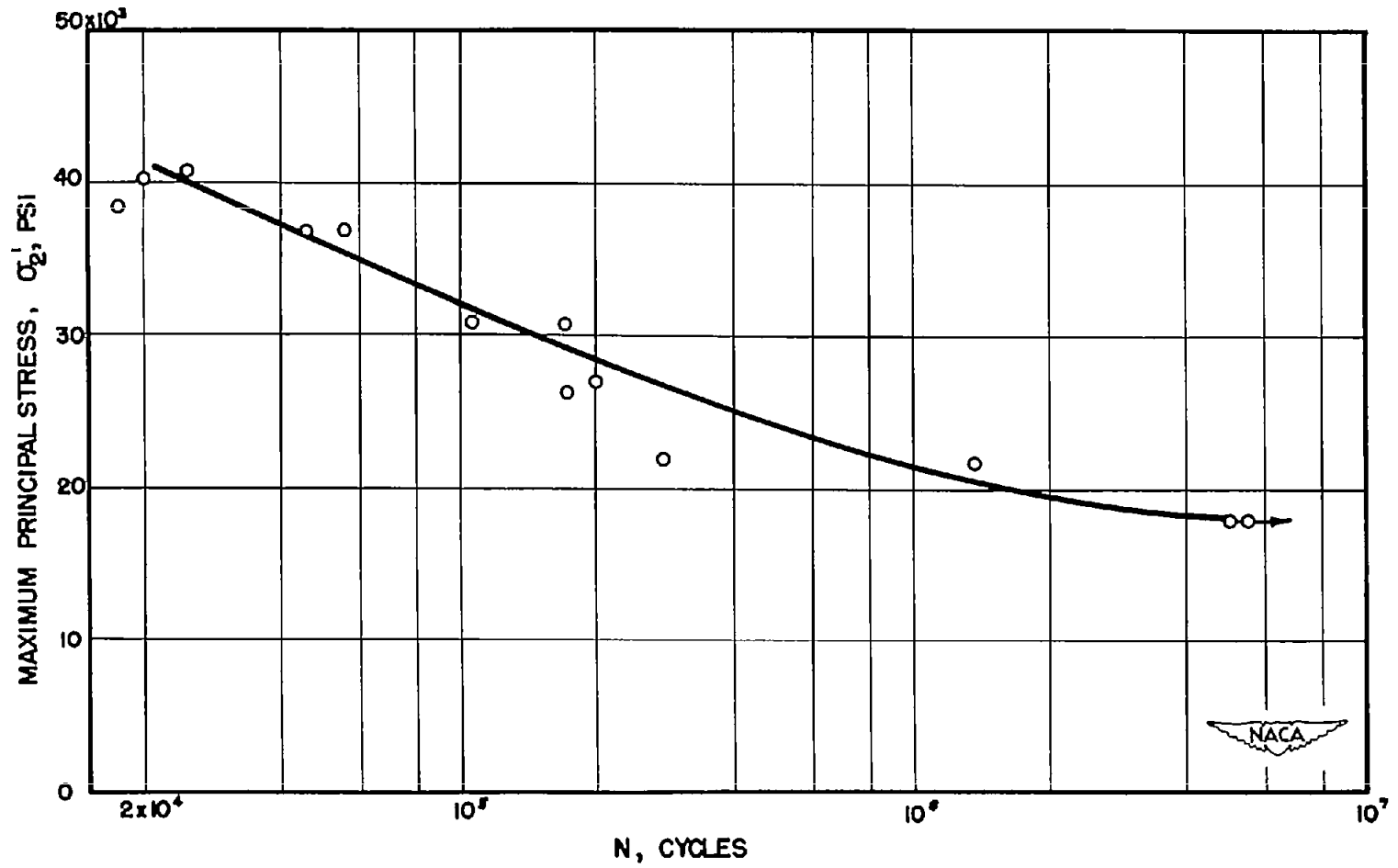
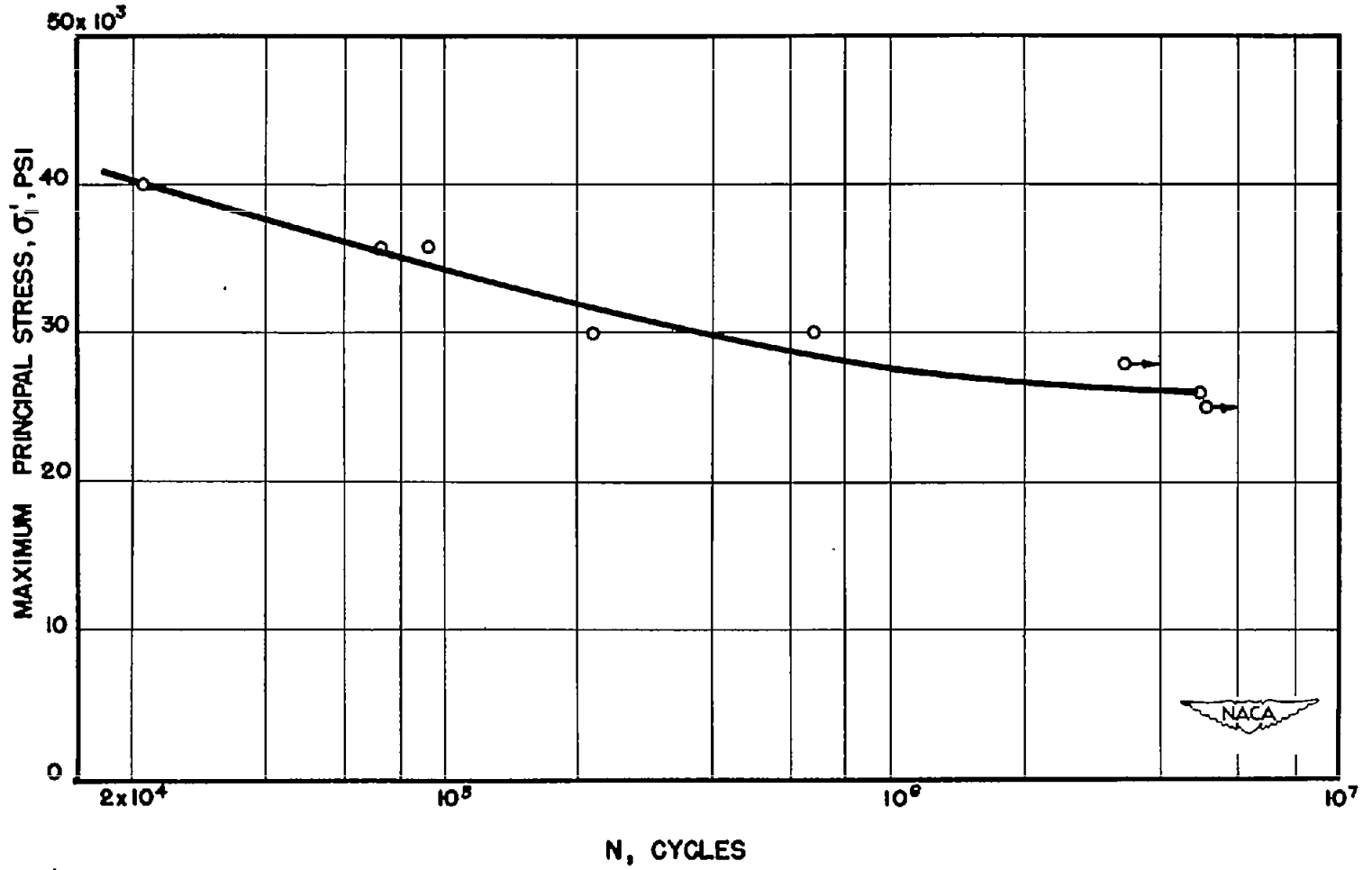

Figure 3.- Strain-measuring equipment.



$$(a) R = \frac{\sigma_2}{\sigma_1} = 2.0.$$

Figure 4.- S-N curves for four principal stress ratios.



$$(b) R = \frac{\sigma_2^i}{\sigma_1^i} = 1.0.$$

Figure 4.- Continued.

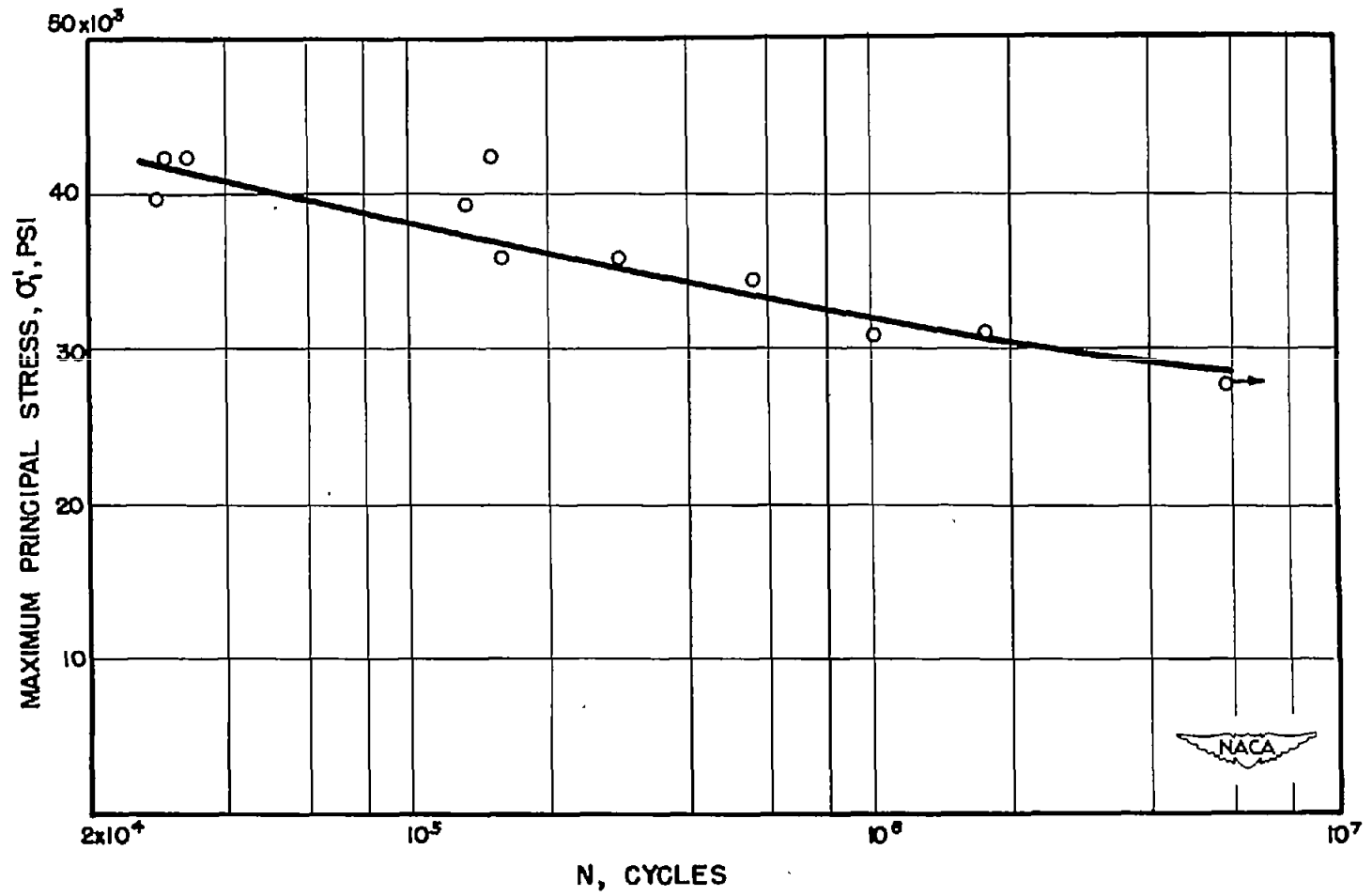

$$(c) \quad R = \frac{\sigma_2'}{\sigma_1'} = 0.$$

Figure 4.- Continued.

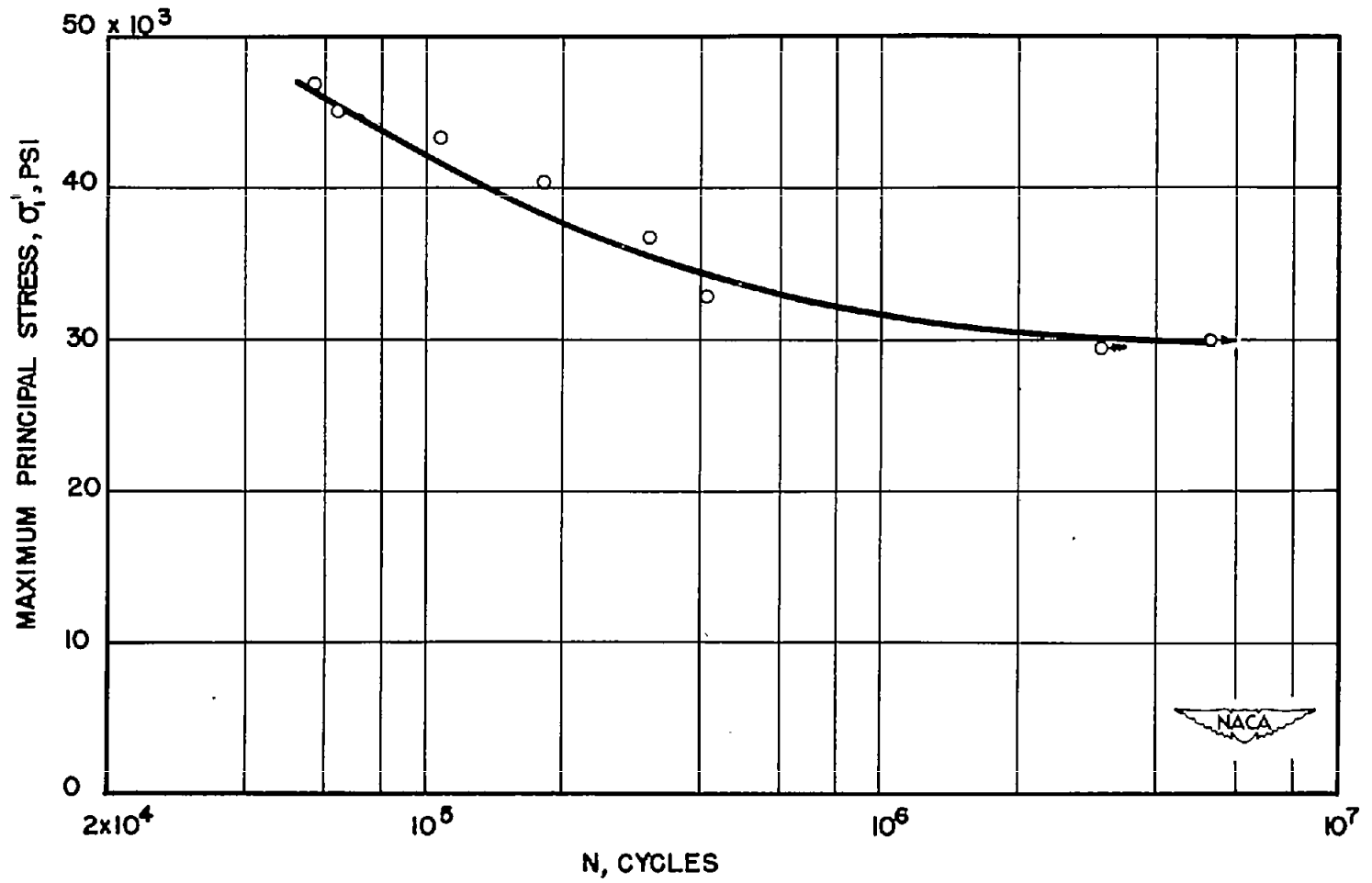

$$(d) R = \frac{\sigma_2'}{\sigma_1'} = 0.5.$$

Figure 4.- Concluded.

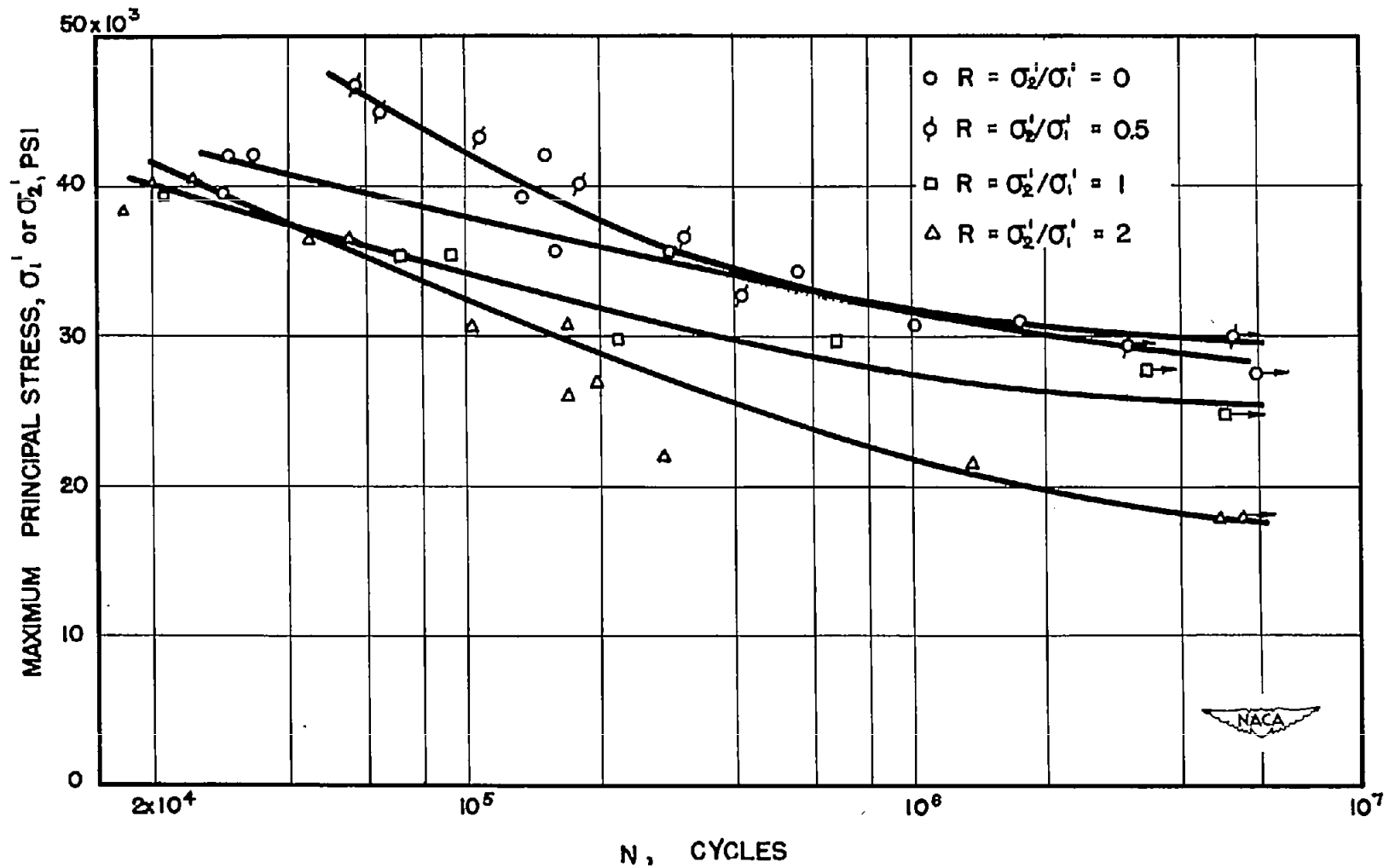

Figure 5.- S-N curves from figure 4 shown in a single plot.

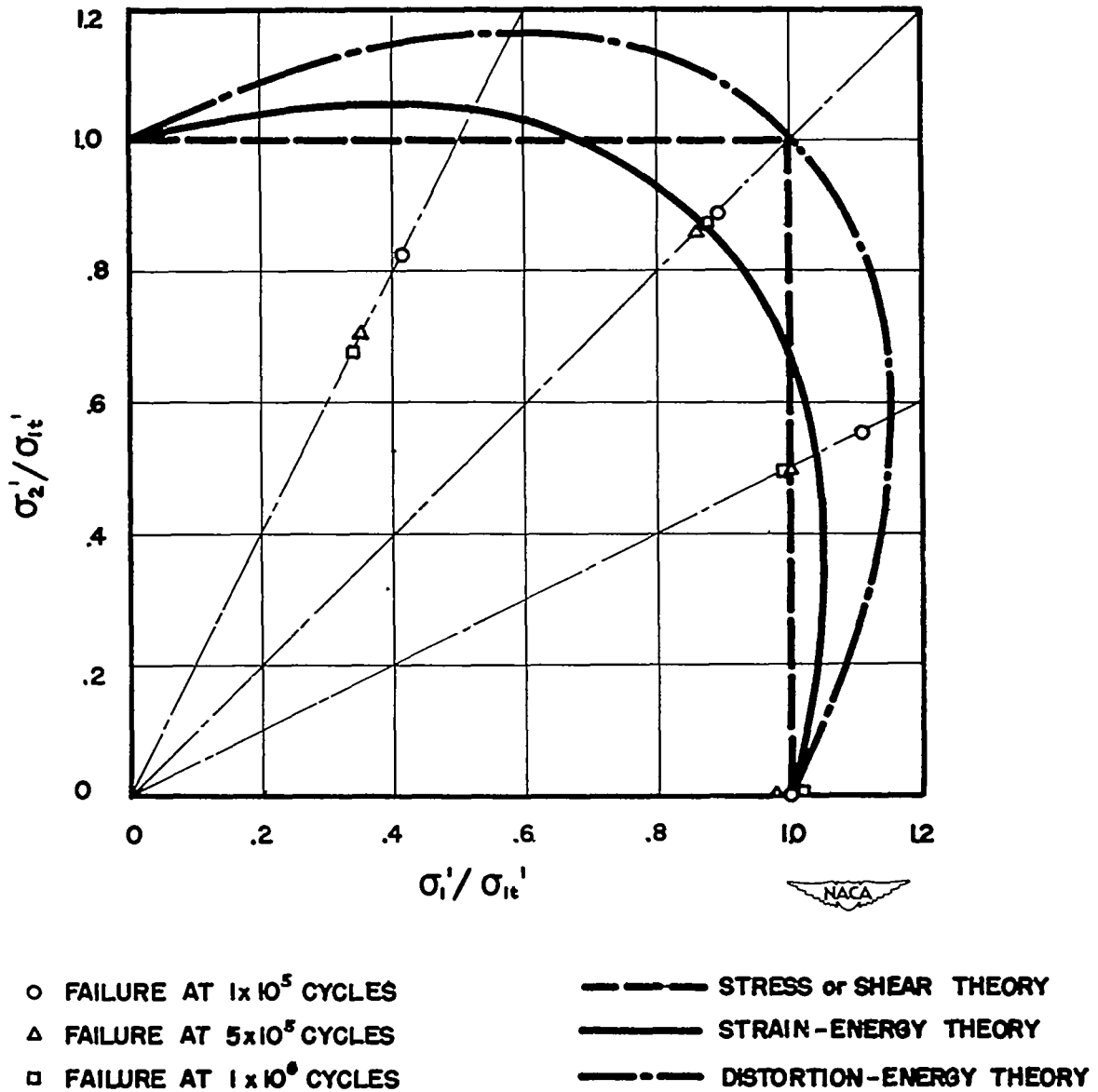

Figure 6.- Biaxial fatigue-stress relationship.

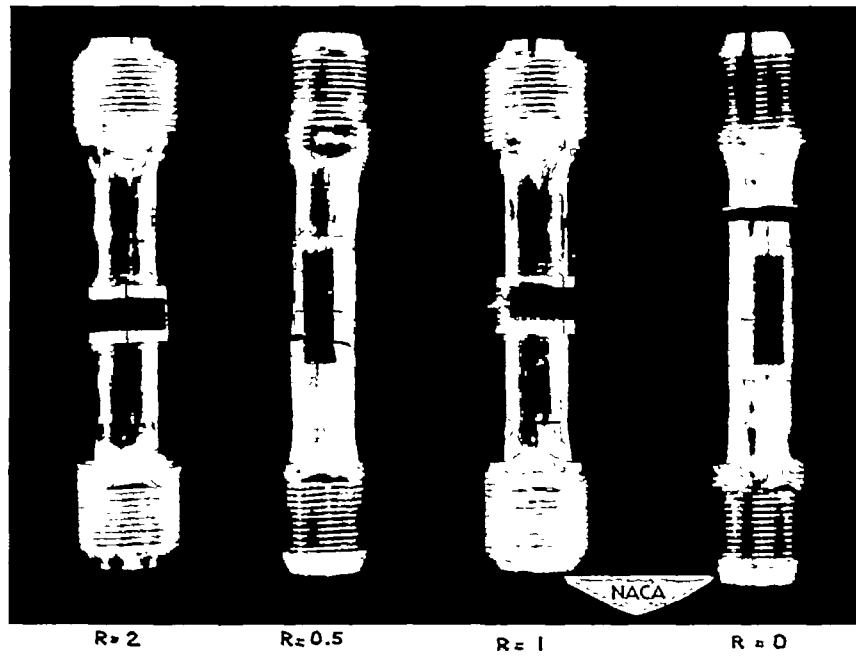

Figure 7.- Typical fractured specimens.