

REPORT DOCUMENTATION PAGE

Form Approved
OMB No. 0704-0188

Public reporting burden for this collection of information is estimated to average 1 hour per response, including the time for reviewing instructions, searching existing data sources, gathering and maintaining the data needed, and completing and reviewing this collection of information. Send comments regarding this burden estimate or any other aspect of this collection of information, including suggestions for reducing this burden to Department of Defense, Washington Headquarters Services, Directorate for Information Operations and Reports (0704-0188), 1215 Jefferson Davis Highway, Suite 1204, Arlington, VA 22202-4302. Respondents should be aware that notwithstanding any other provision of law, no person shall be subject to any penalty for failing to comply with a collection of information if it does not display a currently valid OMB control number. **PLEASE DO NOT RETURN YOUR FORM TO THE ABOVE ADDRESS.**

| | | | | | |
|--|-------------------------|---|---|----------------------------|--|
| 1. REPORT DATE (DD-MM-YYYY) | | 2. REPORT TYPE Conference paper | 3. DATES COVERED (From - To) | | |
| 4. TITLE AND SUBTITLE COTS Networked Ground Sensors for Artillery Localization | | | 5a. CONTRACT NUMBER DAAE30-98-D-1010-0005 | | |
| | | | 5b. GRANT NUMBER | | |
| | | | 5c. PROGRAM ELEMENT NUMBER | | |
| 6. AUTHOR(S) David C. Swanson | | | 5d. PROJECT NUMBER | | |
| | | | 5e. TASK NUMBER | | |
| | | | 5f. WORK UNIT NUMBER | | |
| 7. PERFORMING ORGANIZATION NAME(S) AND ADDRESS(ES) The Applied Research Laboratory The Pennsylvania State University P.O. Box 30, State College, PA 16804 | | | 8. PERFORMING ORGANIZATION REPORT NUMBER | | |
| 9. SPONSORING / MONITORING AGENCY NAME(S) AND ADDRESS(ES) Department of the Army, CECOM RDEC Night Vision & Electronic Sensors Directorate AMSEL-RD-NV-D 10221 Burbeck Road Ft. Belvoir, VA 22060-5806 | | | 10. SPONSOR/MONITOR'S ACRONYM(S) | | |
| | | | 11. SPONSOR/MONITOR'S REPORT NUMBER(S) | | |
| 12. DISTRIBUTION / AVAILABILITY STATEMENT Approved for public release; distribution is unlimited. | | | | | |
| 13. SUPPLEMENTARY NOTES Presented at the 2001 Meeting of the MSS Specialty Group on Battlefield Acoustic & Seismic Sensing, Magnetic & Electric Field Sensors, held on 24-26 October 2001. | | | | | |
| 14. ABSTRACT A commercial off-the-shelf (COTS) design of a ground sensor network is implemented using Windows 2000, wireless 2.4 GHz Ethernet, GPS time synchronization, and solar power. While using low power commercial components, the power budget (including radio and all peripherals) is still a hefty 20 watts, which is low by Pentium-class PC standards, but quite high compared to what is possible using embedded processors. Using Windows 2000 (W2k) and a 533 MHz Celeron processor as a ground sensor platform, offers many advantages. The biggest advantage is that we don't have to develop all the networking and power-saving features built into W2k. Using secure Intranets (private networks on the test range) and secure Extranets (secure landlines connecting the range to the user thousands of miles away), the user can log into the W2k domain and the "network neighborhood" is the ground sensor network. This greatly facilitates engineering development of algorithms, data collection, and proof-of-concept validation by leveraging technology developed for the commercial Internet. Each ground sensor has an 8-channel 24-bit data acquisition system with 4 microphones and a 3-component geophone. The remaining channel digitizes a timing pulse waveform from the GPS which allows each ground sensor to be synchronized within one sample period of the analog conversions. Each node automatically detects an artillery blast, calculates a line of bearing and precise time of arrival, captures and logs environmental data and a short recording of the blast, and sends a message to a server. The server automatically backs up recordings and manages the 20 Gigabytes of disk space on each of the ground sensor nodes. | | | | | |
| 15. SUBJECT TERMS | | | | | |
| 16. SECURITY CLASSIFICATION OF: Unclassified | | | 17. LIMITATION OF ABSTRACT UU | 18. NUMBER OF PAGES | 19a. NAME OF RESPONSIBLE PERSON |
| a. REPORT U | b. ABSTRACT U | c. THIS PAGE U | | | 19b. TELEPHONE NUMBER (include area code) |

COTS Networked Ground Sensors for Artillery Localization

David C. Swanson
The Applied Research Laboratory
The Pennsylvania State University
P.O. Box 30, State College, PA 16804
(814) 865-2448, dcs5@psu.edu

Abstract

A commercial off-the-shelf (COTS) design of a ground sensor network is implemented using Windows 2000, wireless 2.4 GHz Ethernet, GPS time synchronization, and solar power. While using low power commercial components, the power budget (including radio and all peripherals) is still a hefty 20 watts, which is low by Pentium-class PC standards, but quite high compared to what is possible using embedded processors. Using Windows 2000 (W2k) and a 533 MHz Celeron processor as a ground sensor platform, offers many advantages. The biggest advantage is that we don't have to develop all the networking and power-saving features built into W2k. Using secure Intranets (private networks on the test range) and secure Extranets (secure landlines connecting the range to the user thousands of miles away), the user can log into the W2k domain and the "network neighborhood" is the ground sensor network. This greatly facilitates engineering development of algorithms, data collection, and proof-of-concept validation by leveraging technology developed for the commercial Internet. Each ground sensor has an 8-channel 24-bit data acquisition system with 4 microphones and a 3-component geophone. The remaining channel digitizes a timing pulse waveform from the GPS which allows each ground sensor to be synchronized within one sample period of the analog conversions. Each node automatically detects an artillery blast, calculates a line of bearing and precise time of arrival, captures and logs environmental data and a short recording of the blast, and sends a message to a server. The server automatically backs up recordings and manages the 20 Gigabytes of disk space on each of the ground sensor nodes.

This material is based upon work supported by the US ARMY ARDEC under award No. contract DAAE30-98-D-1010, DO 005 .

1. Objective

The objective of this project is to rapidly develop and deploy four truly unattended ground sensors to an artillery range for detection and localization of muzzle blasts and shell detonations. The system must feed into a TCP-IP based file server so that the appropriate digital recordings of acoustic and seismic data can be transported to ARDEC as conveniently as possible. In addition, the receiving nodes must have precise time synchronization even though they are up to 10's of km separated and unattached by wiring for power or communications. The ground sensors obviously have to be relatively low power, but must support some wireless networking with efficient data transfer rates.

To meet this objective, we surveyed a large number of processing platforms ranging from embedded DSP systems up to hardened commercial PC motherboard systems. Much has happened to the PC in recent

years, and we found that a simple commercial motherboard and a low-end Intel Celeron class cpu could easily meet all the requirements, including relatively low power (approximately 20 Watts). However, the real benefit is that all the commercial networking, security, and administration tools are already provided in modern operating systems such as Windows 2000[®] (W2k). This is also true of Linux and a few other operating systems, but the fact that most desktop PC's are running Windows allows many conveniences to be included in the system. Using W2k also allows leveraging of many commercial off-the-shelf (COTS) products for networking, data acquisition, and time synchronization. For example, using build-in file backup utilities, we expect the artillery data to be automatically copied to government file servers for convenient access.

2. Networked Environment

The ground sensors will be deployed initially at Yuma Proving Grounds, which already has a wireless TCP-IP network using Cisco Aeronet 340 bridges, a COTS device for high-speed Internet links between buildings. If needed, these bridges can support bit rates of 11 Mbps at distances of 25 km or more, line of sight. Data and network security is handled using established procedures. Figure 1 depicts the general idea of applying COTS hardware to the artillery localization problem.

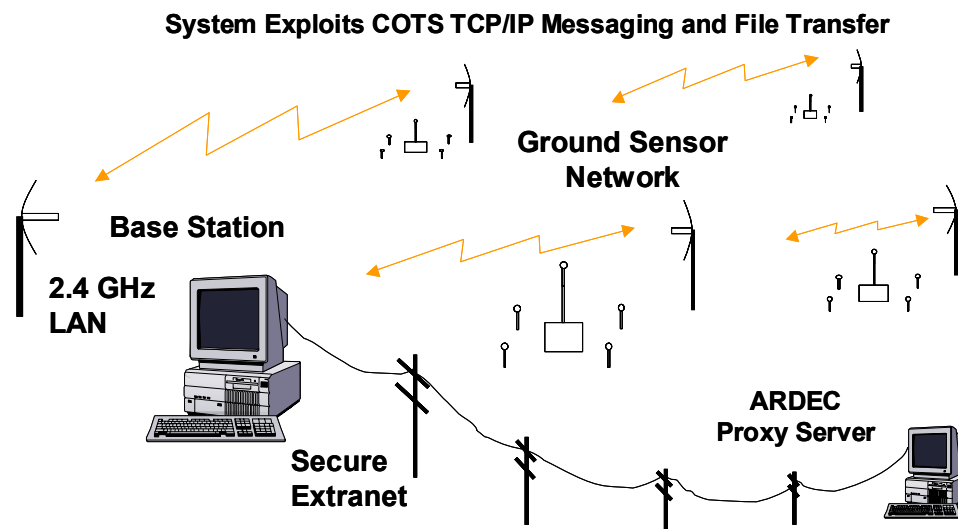

One of the really fun things about the approach depicted in Figure 1 is that when one logs into the primary domain server for the ground sensor network, *the familiar "network neighborhood" in Windows is the ground sensor network*. Any or all of the local hard disk drives can be mapped onto a users desktop machine with access to the secure network and used directly and in real-time for artillery localization algorithm development. This approach effectively exploits the latest tools in information technology and positions the ground sensor nodes for employment in new even lower power platforms. Using a 533 MHz Celeron, only 3% of the available processing power is used including all operating system overhead. As Windows platforms migrate onto cell phone chips in the near future, we expect the 20 Watt load of the ground sensor motherboard to drop to well below 1 Watt.

3. Data Acquisition and Acoustic Seismic Sensors

Have a PCI bus available for data acquisition presents the option for an extremely wide choice of data acquisition systems. We decided to use a 24-bit system capable of up to 96000 samples per second per channel with delta-sigma converters for integral programmable anti-aliasing filters. There are several systems available that meet this requirement. We chose the Chico+ system with two SD modules from Innovative Integration (www.innovative-dsp.com) because it offered a wide range of flexibility for data acquisition and control using the same software drivers. Using new COTS equipment can also bring “Innovative Irritation” and the Chico+ system was not without its firmware bugs, which now appear to be

corrected. Our software architecture uses several layers of buffering and actually has a ring-0 interrupt service routine for W2k. The software can stream data to hard disk via RAM buffers at rates of 96000 samples per second time 8 channels, although we are only using a sample rate of 8000 for the artillery localization system. Electrical power consumed decreases and signal-to-noise ratio (SNR) increases as the sample rate is decreased (the lowest rate supported is 3000 samples per second). We chose 8000 samples per second because it can be conveniently listened to using desktop PC sound boards and provides adequate time resolution for bearing estimates if a 4-microphone array is used. The data is processed as 32-bit floats, preserving the 24-bit raw sample, and we observe about 120 dB of SNR in the time domain at 8kHz sample rate, meaning that we were getting about 19 or 20 useful bits out of the 24-bit system. Figure 2 depicts the buffer completion routine architecture employed in the data acquisition software.

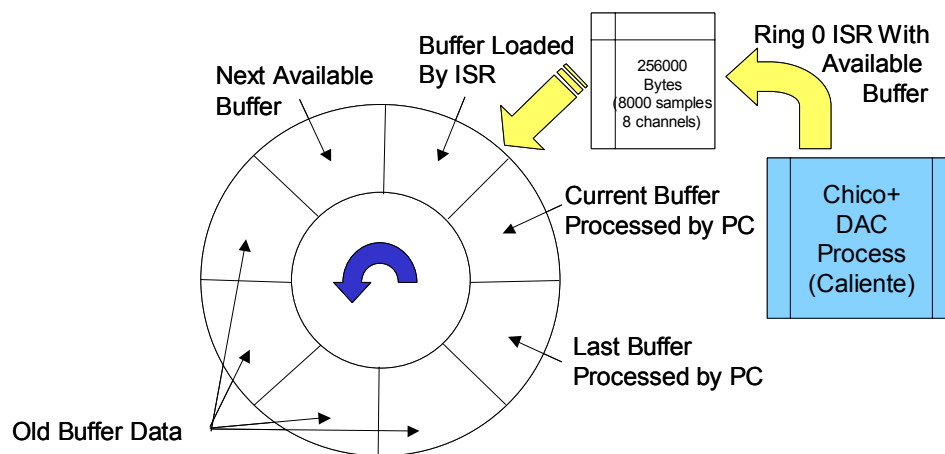

We are using a cross-shaped 4-microphone array with an axis aperture of 1.8m. Mic 1 is to the East with mic 2 1.8m due West, mic 4 is North with mic 3 1.8m due South. This allows straightforward setup using a compass and array layout framework. Time differences of arrival along these two axes allow a bearing of arrival to be computed. The microphones are mounted within 3cm of the ground surface and covered with a porous windscreen pad approximately 12” in diameter.

We’re using the Knowles BL1994 (www.emkayproducts.com/html/bl_1994.htm) piezoelectric microphones because of their robustness to water, temperature, and high sound pressure levels. A 10 Volt dc bias is used to provide a 2.8 Volt swing and a microphone sensitivity of 5.3 mV/Pa. The built-in FET can be bias other ways to enhance the sensitivity and SNR of the mic, but we prefer the lower sensitivity so

that the mic will clip at a high SPL of nearly 150 dB (re 20 uPa). The noise floor of the mic is around 20 dB (re 20 uPa) so we have a system with well-matched sensor and data acquisition board. We apply a non-inverting gain of 11.0 in a preamplifier to match the maximum linear swing of the microphone to the maximum 18 Volt input of the Chico+ SD system.

The geophones are the Oyo-Geospace X-Phone™ (www.geospacelp.com) in a 3-component housing mounted directly under the microphone preamplifiers at the origin of the mic array cross. We can apply up to 80 dBV gain if needed to the geophones with a preamplifier. Careful shield floating and instrumentation amplifiers on the Chico+ SD modules have produced a electronically quiet, well shielded system. Zero 60-Hz interference is observed even if the PC system is operated from AC power.

4. Timing Synchronization

Synchronization of the data from multiple nodes is essential for the artillery localization to work. This problem is solved using a Motorola OnCore™ (www.motorola.com) GPS receiver that produces a rs232-compatible message optimized for time accuracy to 150 ns. The PC Clock is synchronized every minute to the time base of the GPS system. In addition, the GPS outputs a 1 pulse-per-second waveform, where the leading edge of the pulse is within ± 150 ns of the 1-second rollover of the GPS clock system. We input this waveform to be digitized along with the acoustic and seismic waveforms.

When the PC retrieves a block of data from the Chico+ and detects an artillery event, it immediately reads its clock with an accuracy of around ± 50 ms. However, the block examined is already old with respect to real time. The block size is 512 samples long meaning that 16 blocks are processed per second. If we assume we're at most several blocks behind real time, we can say with certainty that the time associated with the detected peak is well within 1 second of real time.

Since we have the 1 pulse per second waveform on one of the data acquisition channels, we can synchronize the recorded data with the GPS time base. All 8 channels are sampled simultaneously using a common time base on the Chico+ using the dual SD modules. If the snapshot recording of the artillery event is 1 second long, we can read back into the recording to find the sample number of the 1-second rollover rise of the GPS-provided 1 pulse per second waveform. Therefore, each ground sensor node has data acquisition synchronized to within 1 sample period, which at an 8 kHz sample rate, is 125 us precision! Considering that sound travels approximately 1.1 feet in 1 ms, that means our ground sensors are time synchronized within several inches, which is much better than the GPS localization possible. The time of arrival fluctuations due to weather can now be fully trusted as not due to experimental error.

5. Power Scavenging and Management

The remote ground sensor nodes are designed to operate continuously. Adding all the power loads we consistently see about 40 Watts required to operate everything. The Chico+ system seems to use a surprising 15 Watts of power. This is the price for 24-bits and about 120 dB of SNR. There is roughly 5 Watts used by the Cisco Ethernet bridge radio and about 20 Watts used by the PC and dc power conversion electronics. While one can purchase a 12 dc ATX power supply, we found two problems with the COTS option. First, the 300 Watt supply was only 70% efficient at full power, and much less efficient at lower powers. Second, the COTS systems all had minimum current loads that translated to about a 100 Watt load. Our system would not draw enough current to match with these supplies. So our "COTS" ground sensor design required us to fabricate a board and design an efficient dc-to-dc converter for the PC motherboard's requirements of 3.3, 5, +12, and -12 Volts dc. The schematic is seen in Figure 3.

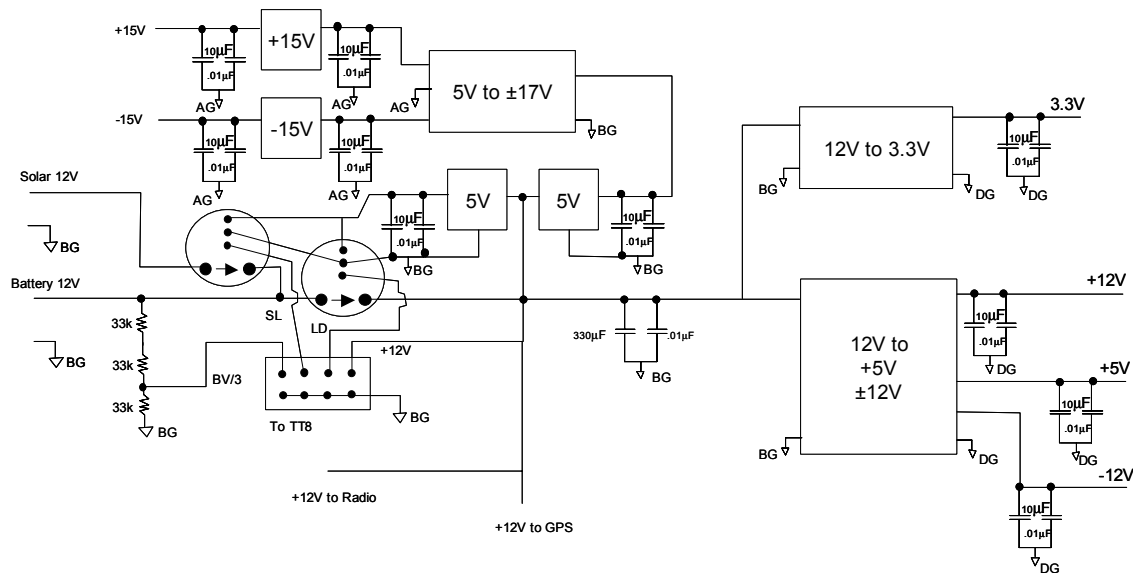

A 65 amp-hour “gel cell” or sealed lead-acid battery provides enough power to run the full ground sensor load approximately 24 hours. The solar cell in full sunlight is rated at 7 amps, or 100 Watts. This provides enough power to run the ground sensor and fully charge the battery during the day, in theory. Voltage and current monitoring is also provided so that we can experiment with different power management techniques. For example, we can use administrative tools to start and stop processes and even shut down the PC to assist in power management.

6. Environmental Sensing

An Onset Computer TT8 (www.onsetcomputer.com) is used to monitor the power, and local wind and temperature. We’ve also added a microphone for future use as a wake-up sensor and digital I/O lines to allow the TT8 to reboot or shut down the PC system if needed. The TT8 is wonderfully simply computer to use. It has 8 channels of 12-bit data acquisition, 2 rs232 ports, 16 lines of digital I/O, a built-in watchdog timer, draws very little power, and runs ANSI C as well as BASIC. Figure 4 shows the TT8 processor.

Local weather sensing is required to obtain the surface winds and temperature gradients. These have an important role in affecting the time difference of arrival as well as multipath propagation in the atmosphere. Wind, temperature, and humidity for the atmosphere up to several km can be obtained for the area (say 60 km by 60 km) via large-scale weather models such as (rapid update cycle), or RUC data. One can use an intelligent agent to go out on the Internet and automatically retrieve and process this data to obtain the information necessary to estimate to sound speed as a function of height and direction.

It is invaluable to have local surface measurements of wind and temperature to greatly improve the model accuracy. Having the sound-relevant atmospheric data plus surface measurement for the ground sensor network area allows on to update sound propagation models for inverting the ground sensor reported arrival times and bearings to estimate the location of the artillery event. Temperature is measure at two heights to provide the gradient estimate and absolute temperature. Wind is measured using two Honeywell 1” water column MEMS pressure sensors, plumbed into 4 ports around a cylinder. The square root of the pressure differences across the ports is proportional to the flow velocity, thus we can calculate the wind speed and direction with no moving parts. The highly sensitive pressure gauges give good wind accuracy from 15 m/s down to 1 m/s.

- TT8 Proven Processor
- < 750 mW
- 8 channels 12-bit ADC
- Monitors
 - Battery Voltage
 - Charge Current
 - Load Current
 - Temperature Gradient
 - Wind Speed and Direction
- \$495 each
- -40 to +85C Operation

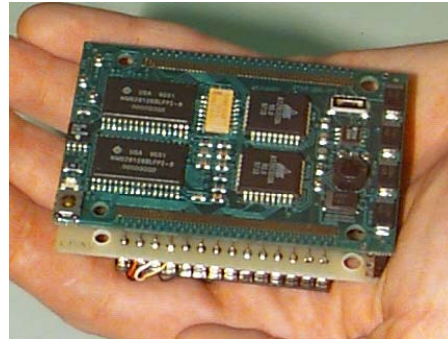
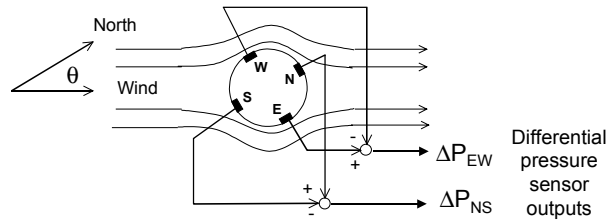

7. Conclusions

Putting together a “COTS Ground Sensor” was great fun, but also had its difficulties. First, the power, which at 40 Watts total is quite low for a W2k PC (a typical laptop consumes 100 Watts), is too high for most practical surveillance systems. The 100 Watt solar cell is 8 square feet and the 65 amp-hour battery weighs nearly 50 lbs. However, looking ahead to future products by Intel and others, we see single-chip PC’s for mobile devices like cell phones and pocket PC’s with enough processing power to run Windows CE and support external inputs via the USB that have enough capability to support a ground sensor system. Furthermore, the Web and IT technology emerging can make this a viable platform for multi-national peacekeeping and counter-terrorism surveillance efforts.

The most difficult engineering task we encountered was building a dc supply capable of mimicking the standard PC ATX supply. This was difficult because there are so many things a modern ATX motherboard does to insure good power to the cpu. There also are many power management processes and concerns about cooling and digital noise to isolate from the sensitive analog channels.

The nodes are planned for installation at Yuma in November, 2001. We expect to have state of the art data available for analysis at ARDEC shortly thereafter. Even though our design approach is not optimized for size, power requirements, or deployment, it appears that we have something very convenient and applicable in the future as the marketplace improves the technology precisely in the direction we need it to go. There goes the [network] neighborhood...