

Advancing Systems Engineering Practice using Model Based Systems Development (MBSD)

Systems & Software Technology Conference

26-29 April, 2010



Sanford Friedenthal
Lockheed Martin
sanford.friedenthal@lmco.com

Report Documentation Page

Form Approved
OMB No. 0704-0188

Public reporting burden for the collection of information is estimated to average 1 hour per response, including the time for reviewing instructions, searching existing data sources, gathering and maintaining the data needed, and completing and reviewing the collection of information. Send comments regarding this burden estimate or any other aspect of this collection of information, including suggestions for reducing this burden, to Washington Headquarters Services, Directorate for Information Operations and Reports, 1215 Jefferson Davis Highway, Suite 1204, Arlington VA 22202-4302. Respondents should be aware that notwithstanding any other provision of law, no person shall be subject to a penalty for failing to comply with a collection of information if it does not display a currently valid OMB control number.

1. REPORT DATE APR 2010	2. REPORT TYPE	3. DATES COVERED 00-00-2010 to 00-00-2010			
4. TITLE AND SUBTITLE Advancing Systems Engineering Practice using Model Based Systems Development (MBSD)		5a. CONTRACT NUMBER			
		5b. GRANT NUMBER			
		5c. PROGRAM ELEMENT NUMBER			
6. AUTHOR(S)		5d. PROJECT NUMBER			
		5e. TASK NUMBER			
		5f. WORK UNIT NUMBER			
7. PERFORMING ORGANIZATION NAME(S) AND ADDRESS(ES) Lockheed Martin,Cherry Hill,NJ,08002		8. PERFORMING ORGANIZATION REPORT NUMBER			
9. SPONSORING/MONITORING AGENCY NAME(S) AND ADDRESS(ES)		10. SPONSOR/MONITOR'S ACRONYM(S)			
		11. SPONSOR/MONITOR'S REPORT NUMBER(S)			
12. DISTRIBUTION/AVAILABILITY STATEMENT Approved for public release; distribution unlimited					
13. SUPPLEMENTARY NOTES Presented at the 22nd Systems and Software Technology Conference (SSTC), 26-29 April 2010, Salt Lake City, UT. Sponsored in part by the USAF. U.S. Government or Federal Rights License					
14. ABSTRACT					
15. SUBJECT TERMS					
16. SECURITY CLASSIFICATION OF:			17. LIMITATION OF ABSTRACT	18. NUMBER OF PAGES	19a. NAME OF RESPONSIBLE PERSON
a. REPORT unclassified	b. ABSTRACT unclassified	c. THIS PAGE unclassified	Same as Report (SAR)	23	

Topics

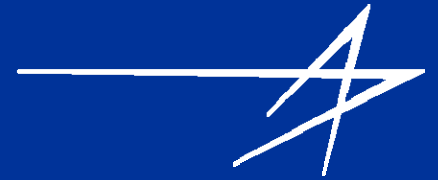

- **Model-based Systems Development (MBSD)
Motivation and Scope**
- **System Modeling Using SysML**
- **System Model as an Integration Framework**
- **Deploying MBSD into your Organization**
- **Summary**

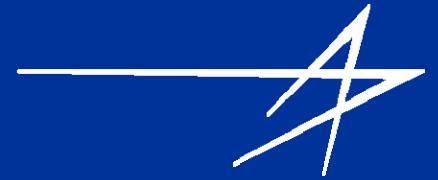

MBSD Motivation and Scope

Practices for Describing Systems

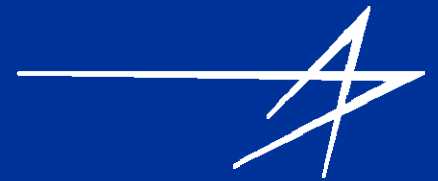

Past



- Specifications
- Interface requirements
- System design
- Analysis & Trade-off
- Test plans

Future

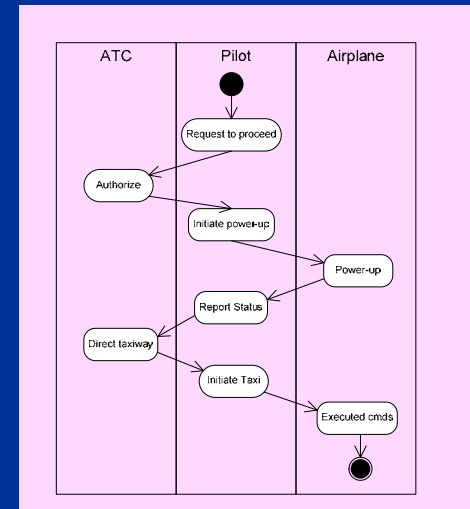

Moving from Document centric to Model centric

Model-based Systems Development (MBSD)

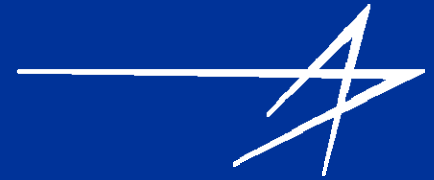

- Formalizes the practice of systems development through use of models
- Broad in scope
 - Integrates with multiple modeling domains across life cycle from system of systems to component
- Results in quality/productivity improvements & lower risk
 - Rigor and precision
 - Communications among system/project stakeholders
 - Management of complexity

Life Cycle Support

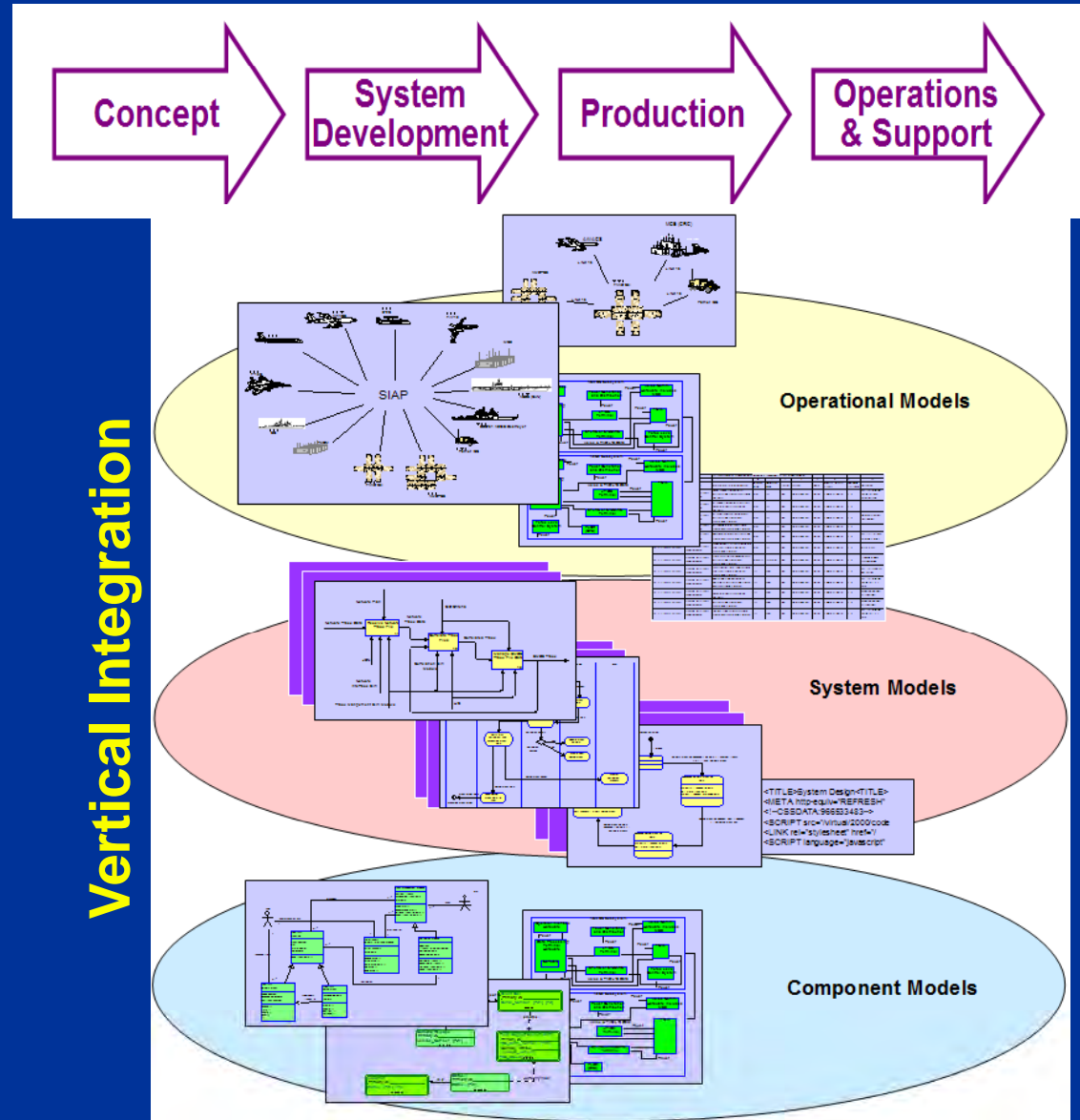

System Description

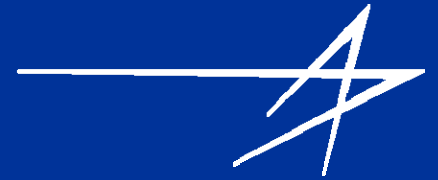

- *Document-Based System Engineering:*

Where is truth?

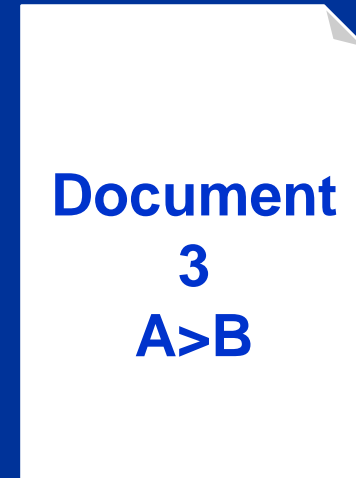
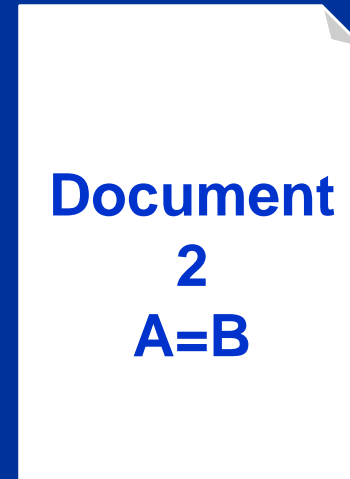
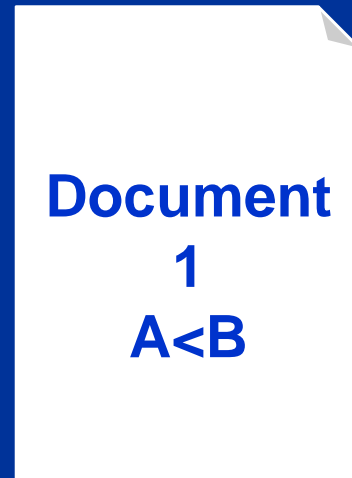

Inconsistencies within and among documents

- *Model-Based System Engineering:*



Model enforces consistency

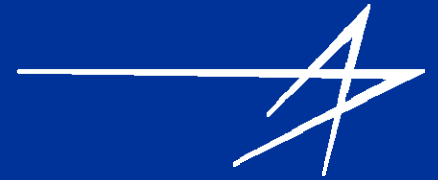

System Modeling Using SysML

System Modeling

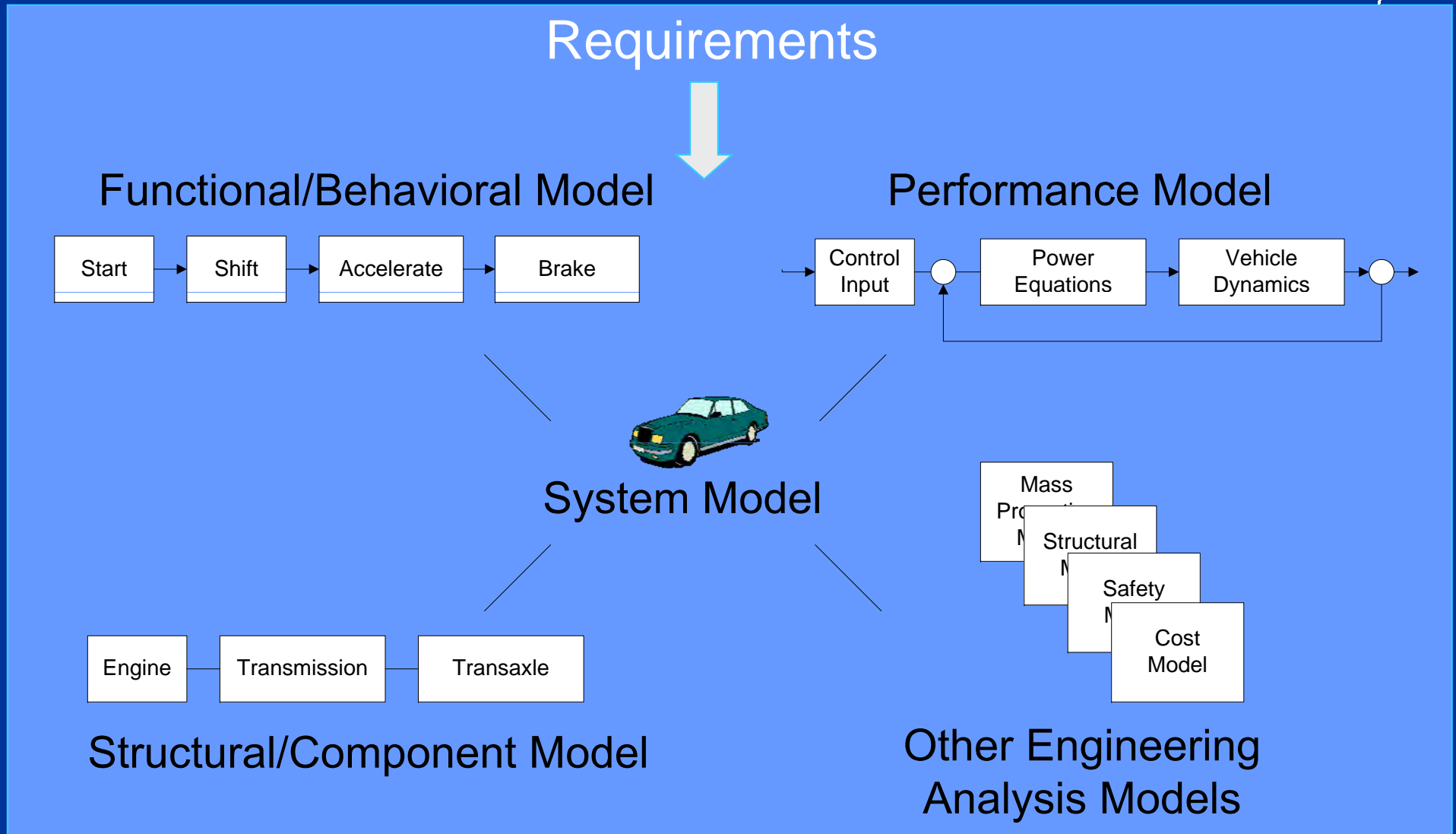

Integrated System Model Must Address Multiple Aspects of a System

What is SysML?

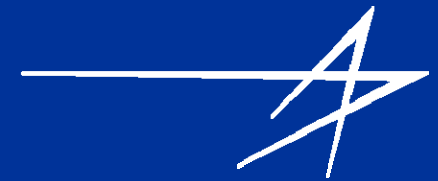

- **A graphical modeling language in response to the UML for Systems Engineering RFP developed by the OMG, INCOSE, and AP233**
 - a UML Profile that represents a subset of UML 2 with extensions
- **Supports the specification, analysis, design, verification, and validation of systems that include hardware, software, data, personnel, procedures, and facilities**
- **Supports model and data interchange via XML Metadata Interchange (XMI®) and the evolving AP233 standard (in-process)**

SysML is Critical Enabler for MBSE

SysML Diagram Taxonomy

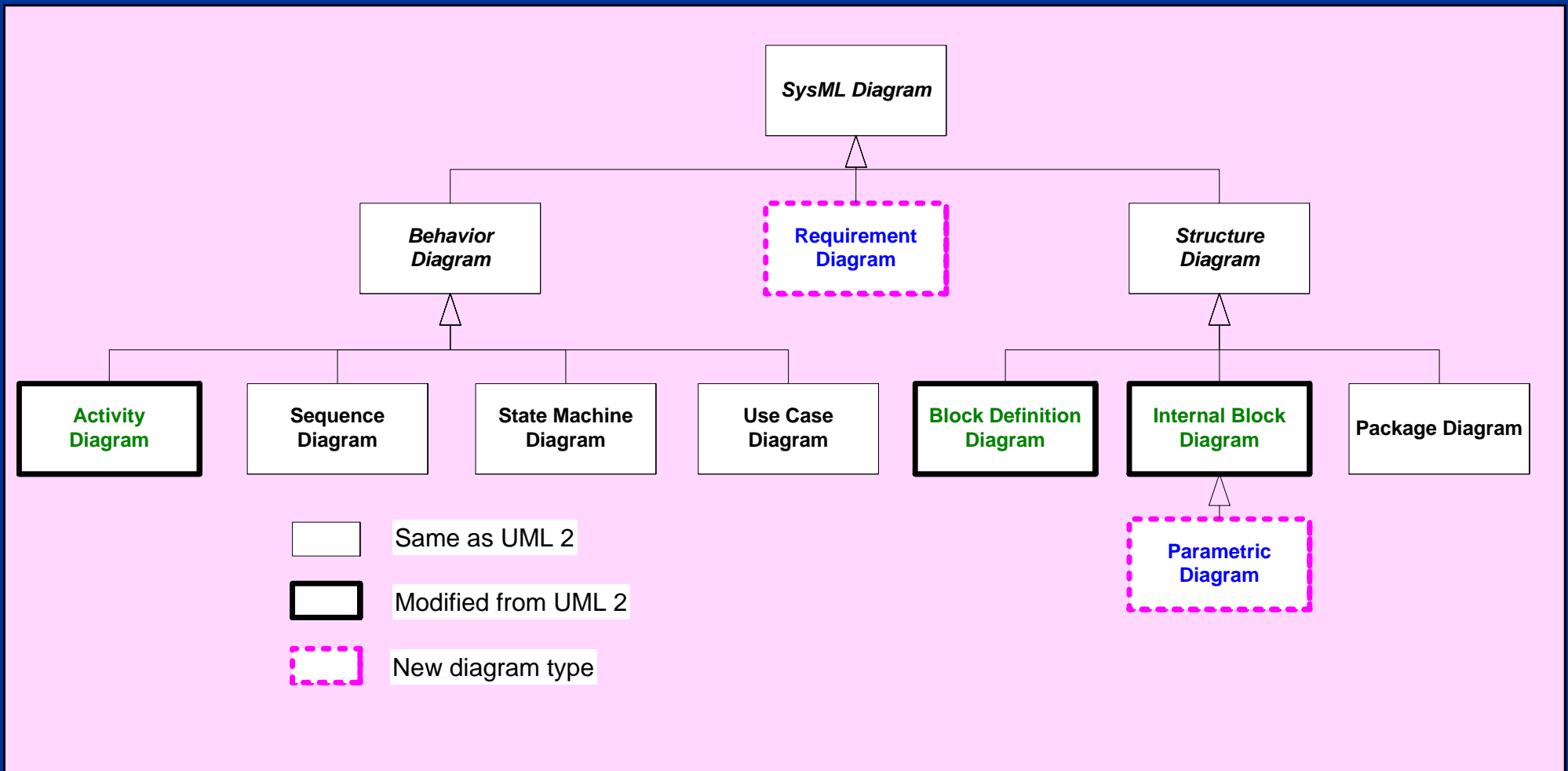
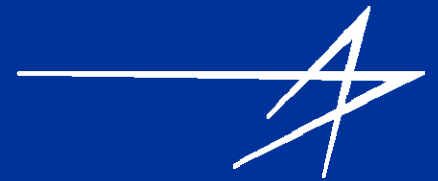

4 Pillars of SysML – ABS Example



1. Structure

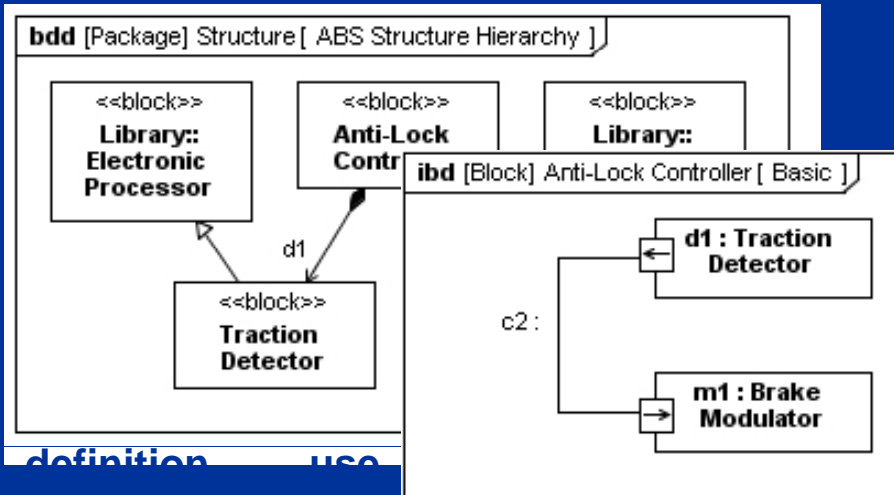

2. Behavior

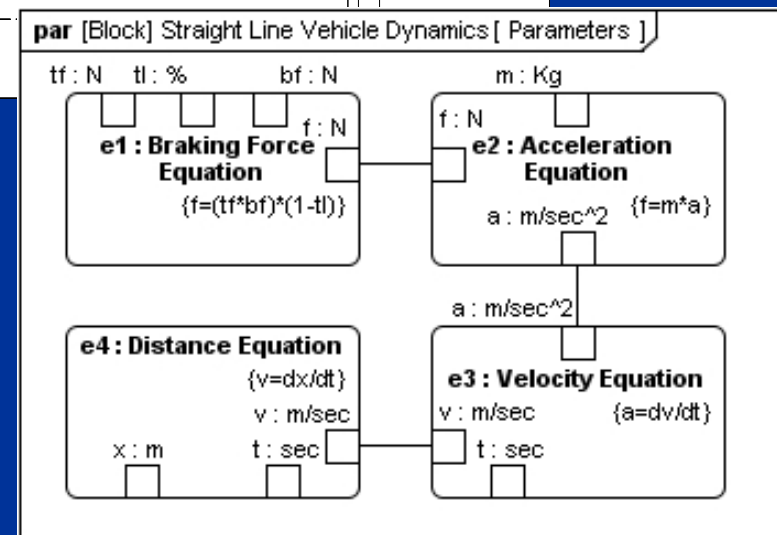
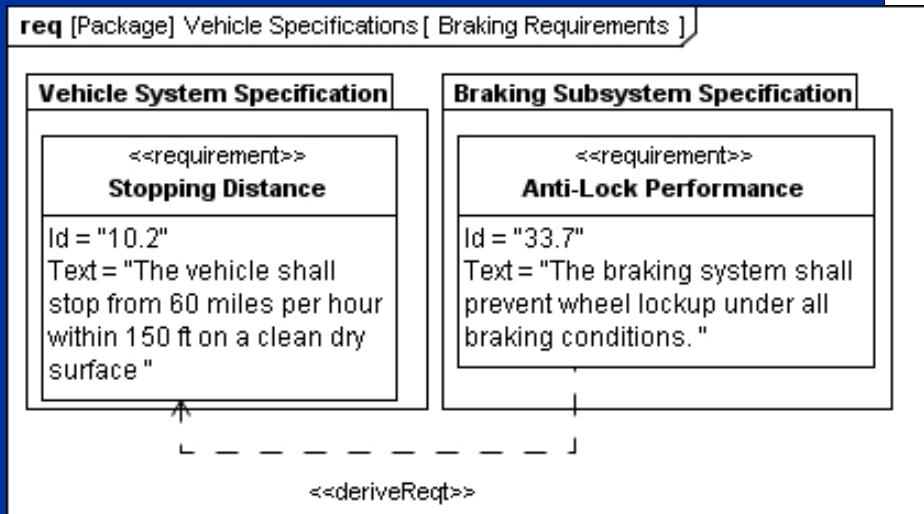
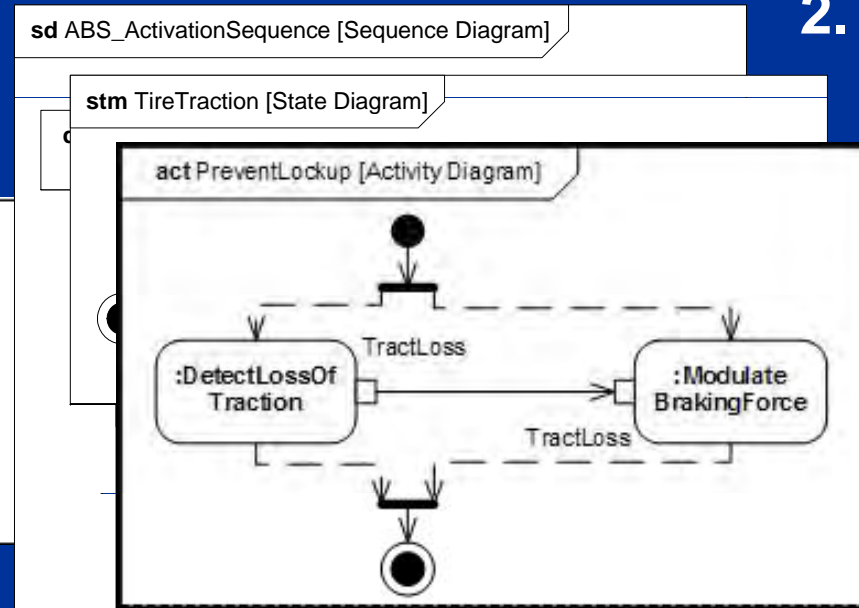

3. Requirements

4. Parametrics

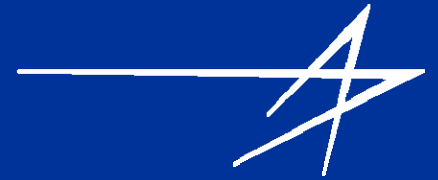

System Model as an Integration Framework

MBSD Must Integrate across Modeling Domains

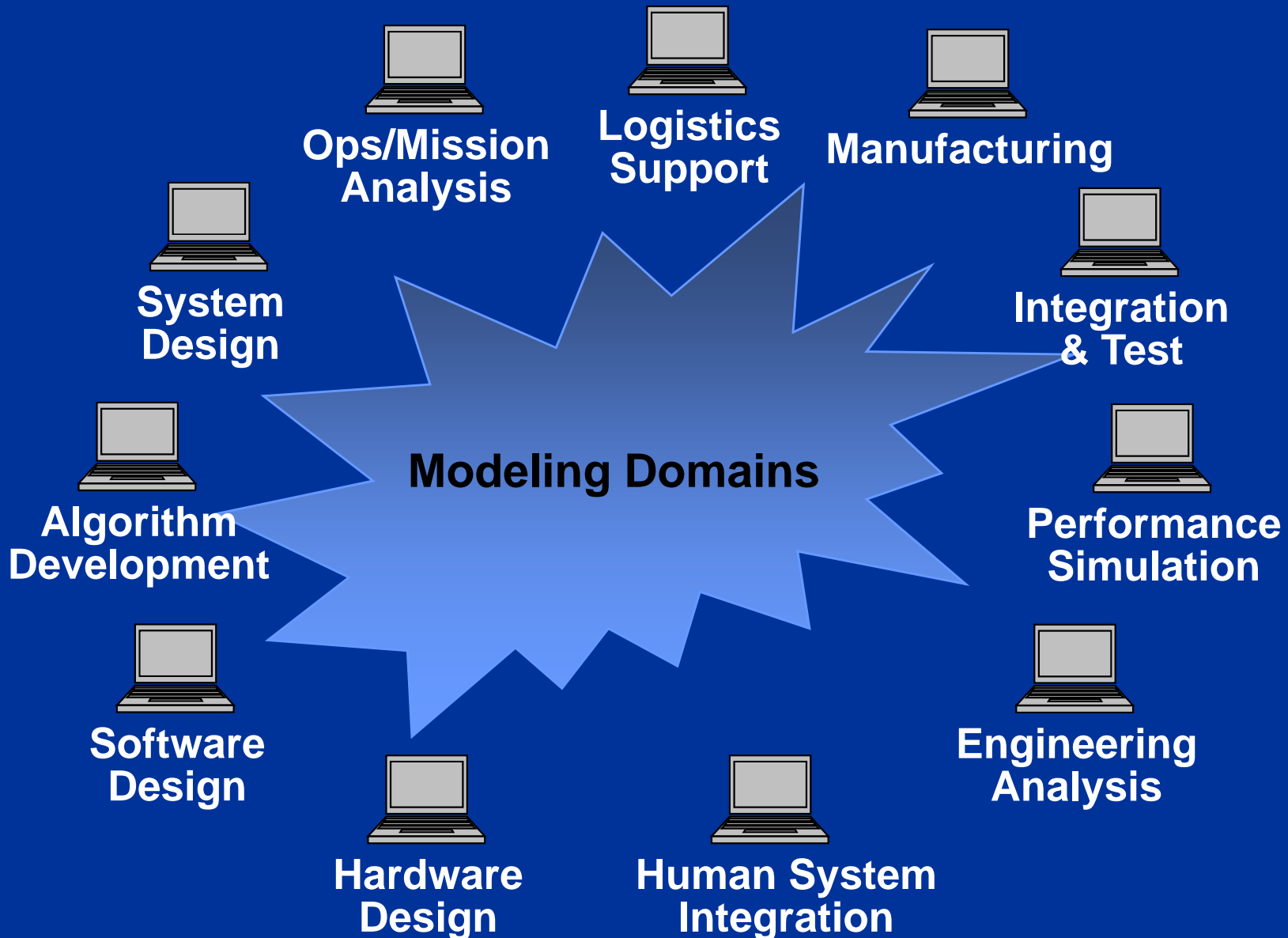

Using System Architecture Model as an Integration Framework

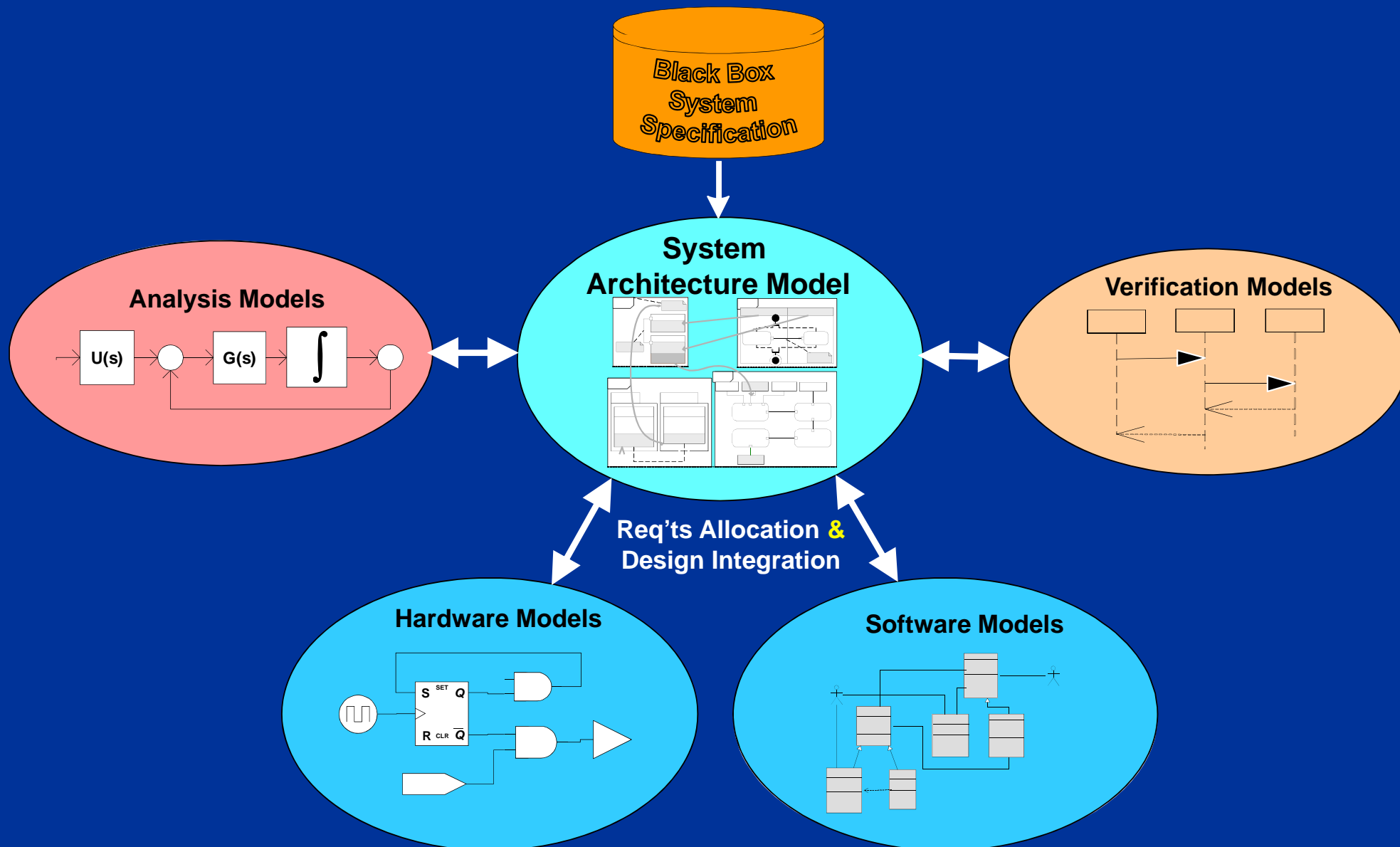
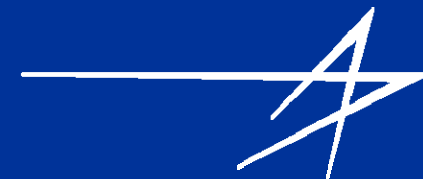

Using the System Architecture Model to Flowdown Requirements



System-of-System Level

- 1st Level Of Decompositions
- How Our System Contributes to the Overall Mission

Mission Concept of Operations

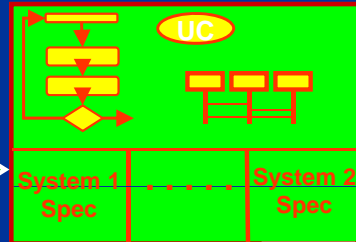

Trade Studies, Simulation, Specification Reviews, etc.

System Level

- Derives Subsystems
- Allocates Requirements to Subsystems



A-Spec

Subsystems

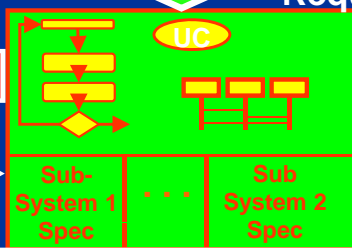

Behavior, Structure & Requirements

Trade Studies, Simulation, Specification Reviews, etc.

Element Level

- Derives Hardware and Software Components
- Allocates Requirements to Components



B-Spec

Components

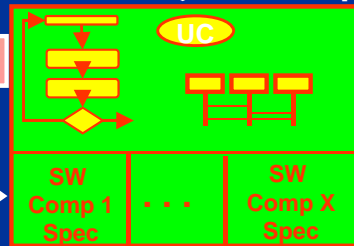

Behavior, Structure & Requirements

Trade Studies, Simulation, Specification Reviews, etc.

Component Design & Implementation Level

(from John Watson/LMC SysML Info Days presentation)

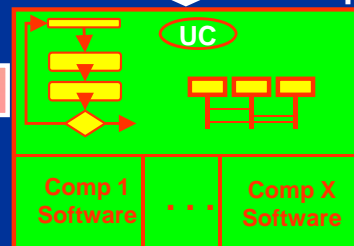

Behavior, Structure & Requirements

System Decomposition Process using SysML

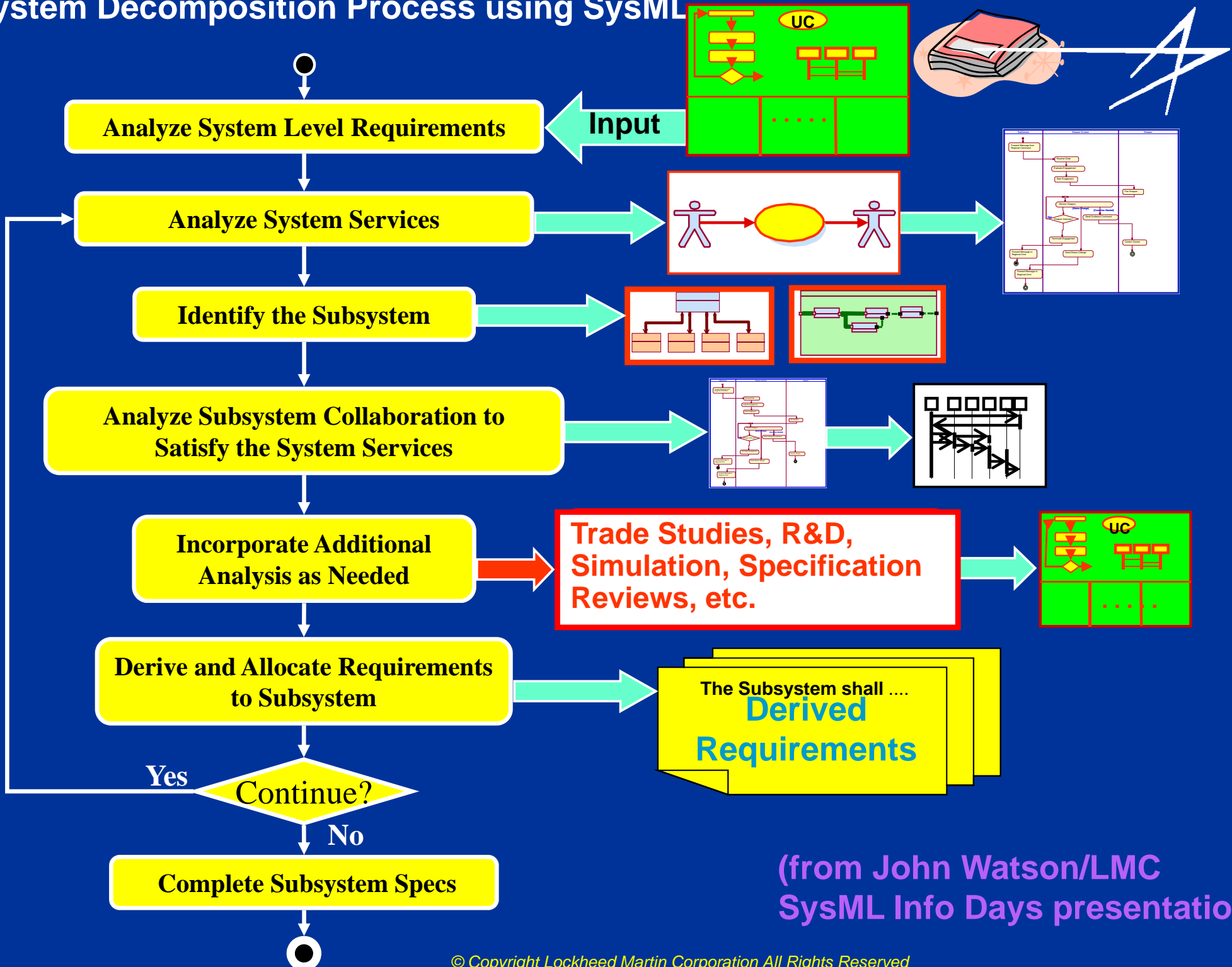

(from John Watson/LMC SysML Info Days presentation)

System Architecture Model to Support Tradeoff Analysis

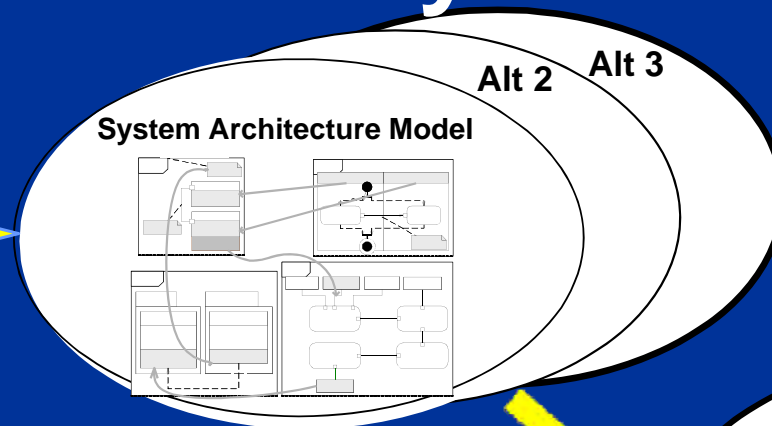
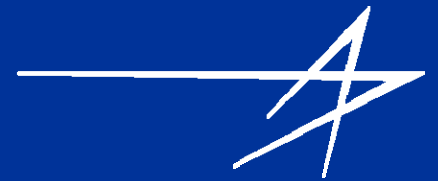

Analysis Results

Subsystem	Alternative1	Alternative2	Alternative3
Sensor	Sensor1	Sensor2	Sensor3
Processor	Processor1	Processor2	Processor3
Control	Control1	Control2	Control3

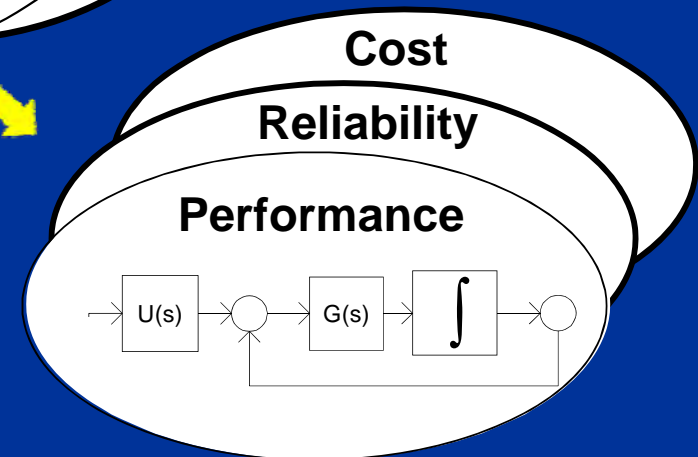

Criteria	Weight	Alt 1	Alt 2	Alt 3
Performance	0.5	7	5	5
Reliability	0.2	4	6	5
Cost	0.3	3	5	8
Effectiveness		5.2	4.2	<u>5.9</u>

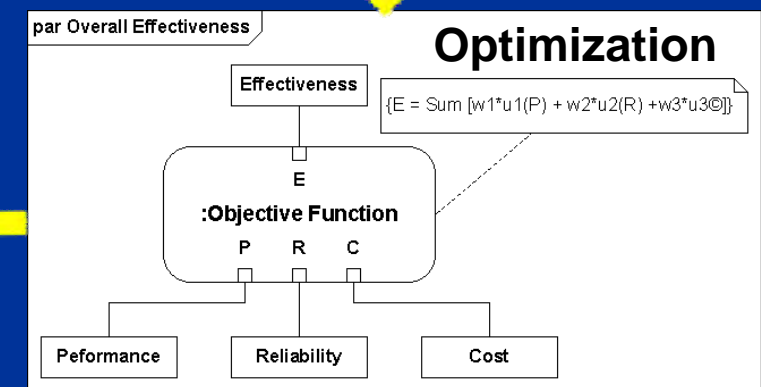

Integrating SysML with Simulation GIT* Project

Modelica

Lexical Representation

(auto-generated from SysML)

```
*ExcavatorExample.mo
package ExcavatorExample
...
class ExcavatorDigCycle
  Modelica.Mechanics.MultiBody.World world;
  ExcavatorExample.Components.Hydraulics hydraulics(redeclare
  ExcavatorModel.SubSystems.DigCycleSeq command(startTime=0.1)
  ExcavatorModel.SubSystems.MechanicsBody body(swing_phi_start
  ExcavatorExample.Interfaces.Nodes.TransNode2 node;
equation
  connect(hydraulics.boomCylBaseL, body.cylBoomLeftBase);
  connect(hydraulics.boomCylRodR, body.cylBoomRightRod);
  connect(hydraulics.boomCylRodL, body.cylBoomLeftRod);
  connect(hydraulics.armCylRod, body.cylArmRod);
  connect(hydraulics.armCylBase, body.cylArmBase);
  connect(hydraulics.bucketCylRod, body.cylBucketRod);
  connect(hydraulics.bucketCylBase, body.cylBucketBase);
  connect(hydraulics.commandSignal, command.commandSignal);
  connect(world.frame_b, body.baseFrame);
  connect(hydraulics.swingFlange, body.swingFlange);
  connect(hydraulics.boomCylBaseR, node.a);
  connect(node.b, body.cylBoomRightBase);
end ExcavatorDigCycle;
end ExcavatorExample;
```

[Johnson, 2008 - Masters Thesis]

* Georgia Institute of Technology

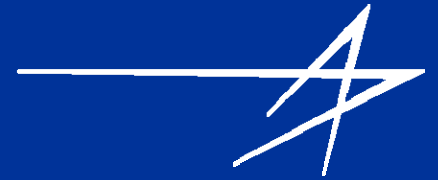

Deploying MBSD into Your Organization

Deploying MBSD as part of Improvement Process

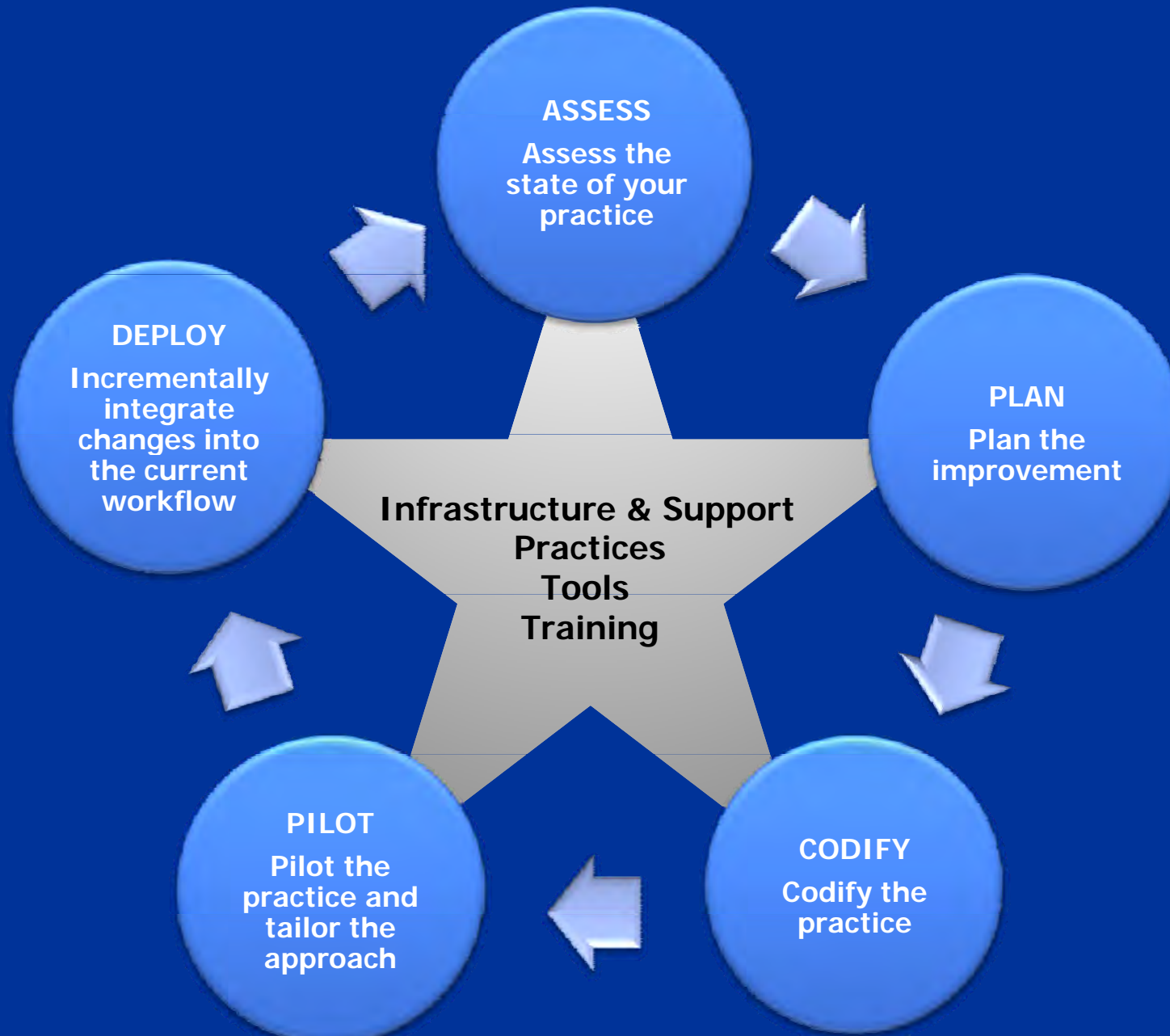
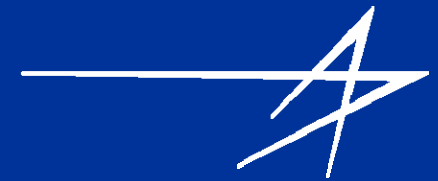

MBSD Observations

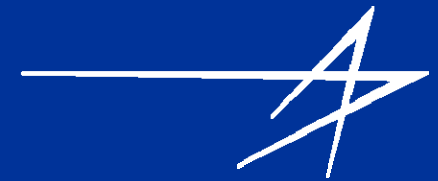

- **Transition from document-centric to model-centric is a cultural change**
- **Well defined MBSE method is essential**
- **Multiple tool vendors provide a range of price point, capability, and standards conformance**
- **MBSE training should include language, method, and tools**
- **Employ pilots to validate your MBSE approach**
- **Need buy-in from program and customer on MBSE benefits, approach and deliverables**
- **Scope model to support program objectives and within program constraints**
- ***A lot has been learned, but much more remains***

Summary

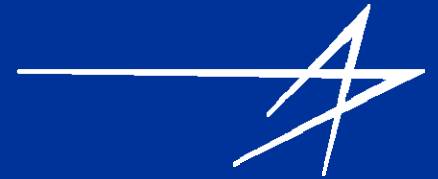

- **MBSD is a key practice to advance complex systems development**
- **Standards such as SysML and UML are critical enablers of MBSD**
- **Multiple tool vendors implementing SysML**
- **System architecture model and standards based approach facilitate integration across modeling domains**
- **Growing interest and application of MBSD**

Acronyms

- **MBSD – Model-based Systems Development**
- **MBSE – Model-based Systems Engineering**
- **OMG – Object Management Group**
- **SysML – Systems Modeling Language**
- **UML – Unified Modeling Language**