

REPORT DOCUMENTATION PAGE**Form Approved
OMB No. 0704-0188**

Public reporting burden for this collection of information is estimated to average 1 hour per response, including the time for reviewing instructions, searching data sources, gathering and maintaining the data needed, and completing and reviewing the collection of information. Send comments regarding this burden estimate or any other aspect of this collection of information, including suggestions for reducing this burden to Washington Headquarters Service, Directorate for Information Operations and Reports, 1215 Jefferson Davis Highway, Suite 1204, Arlington, VA 22202-4302, and to the Office of Management and Budget, Paperwork Reduction Project (0704-0188) Washington, DC 20503.

PLEASE DO NOT RETURN YOUR FORM TO THE ABOVE ADDRESS.**1. REPORT DATE (DD-MM-YYYY)**

27-03-2012

2. REPORT TYPE

FINAL

3. DATES COVERED (From - To)

18-02-2008 - 31-12-2011

4. TITLE AND SUBTITLE

Northwest Manufacturing Initiative

5a. CONTRACT NUMBER**5b. GRANT NUMBER**

W911NF-08-1-0046

5c. PROGRAM ELEMENT NUMBER**6. AUTHOR(S)**

Evans, J. Rick; Fuller, Ellen A.; Chalkiopoulos, Mary; Barrett, Brice; Wood, William E.; Talla, Rajarsekar; Kadali, Jyothi; Nordstrom, Richard; Quale, Thomas; Aronson, Jesse

5d. PROJECT NUMBER**5e. TASK NUMBER****5f. WORK UNIT NUMBER****7. PERFORMING ORGANIZATION NAME(S) AND ADDRESS(ES)**Organization for Economic Initiatives, Inc.
1144 Gateway Lp Ste 203
Springfield OR 97477-7750**8. PERFORMING ORGANIZATION
REPORT NUMBER****9. SPONSORING/MONITORING AGENCY NAME(S) AND ADDRESS(ES)**US Army RDECOM ACQCTR - W911NF; 4300 S. Miami Blvd.; Durham NC
27703**10. SPONSOR/MONITOR'S ACRONYM(S)**

Monitoring Agency: ONRRO; 300 Fifth Ave., Suite 710; Seattle WA 98104

**11. SPONSORING/MONITORING
AGENCY REPORT NUMBER****12. DISTRIBUTION AVAILABILITY STATEMENT**

Approved for public release; distribution unlimited.

13. SUPPLEMENTARY NOTES

The views, opinions and/or findings contained in this report are those of the author(s) and should not be construed as an official Department of the Army position, policy or decision, unless so designed by other documentation.

14. ABSTRACT

The Northwest Manufacturing Initiative, through its partner organizations, has conducted research into Northwest defense industrial base capability gaps, primarily through manufacturing workforce assessment and targeted training, including Lean Manufacturing, Leadership and Supervisory Training, and Project Management, resulting in increased and retained sales and job creation. A database to optimize manufacturing buyer/supplier connections, called the NW Connector, was also developed. In addition, we sought to address defense systems engineering gaps through university based research and development focusing on improving or extending defense equipment lifecycles by determining plane strain fracture toughness, fatigue crack growth and threshold stress corrosion cracking and intensity levels for Carpenter Technology Custom 465 and Ferrium S53. The impact of ultrasonic impact treatment, advanced gas metal arc welding, cold metal transfer, electrospark discharge surfacing on these alloys were also assessed.

15. SUBJECT TERMS

Lean Manufacturing; NW Connector; Custom 465; Ferrium S53; 300M; 4340; Stellite 21; fracture toughness; fatigue crack growth; threshold stress corrosion cracking; rise step load; acoustic emission; ultrasonic impact treatment; electrospark deposition, fully reversed bending fatigue; residual stress; electron microscopy, ESD heat affected zone; residual stress depth profiles

16. SECURITY CLASSIFICATION OF:a. REPORT
Ub. ABSTRACT
Uc. THIS PAGE
U**17. LIMITATION OF
ABSTRACT**
UL**18. NUMBER
OF PAGES**
315**19a. NAME OF RESPONSIBLE PERSON**
J. RICK EVANS**19b. TELEPHONE NUMBER (Include area code)**
541-756-5596

Northwest Manufacturing Initiative

Grant W911NF-08-1-0046

Mr. Rick Evans, Principal Investigator

**Organization for Economic Initiatives, Inc.
1144 Gateway Loop, Suite 203
Springfield OR 97477-7750**

Prepared By:

**J. Rick Evans and Ellen A. Fuller
Oregon Manufacturing Extension Partnership
Pacific Northwest Defense Coalition
Portland State University
Worksystems, Inc.**

27 March 2012

Final Report

Unclassified

Approved for public release; distribution unlimited.

The views, opinions and/or findings contained in this report are those of the author(s) and should not be construed as an official Department of the Army position, policy or decision, unless so designed by other documentation.

**US ARMY RDECOM ACQ CTR – W911NF
4300 S. MIAMI BLVD
DURHAM NC 27703**

TABLE OF CONTENTS

Foreward	1
Executive Summaries	
Oregon Manufacturing Extension Partnership (OMEP) Executive Summary	2
Pacific Northwest Defense Coalition (PNDC) Executive Summary	2
Portland State University (PSU) Executive Summary	3
Worksystems, Inc. (WSI) Executive Summary	4
Appendices	
Appendix A - OMEP Final Report	8
Appendix B - PNDC Final Report.....	16
Appendix C - PSU Final Report	122
Appendix D - WSI Final Report.....	307

Foreword

The Organization for Economic Initiatives, Inc. (OEI) is pleased to submit this final progress report for W911NF-08-1-0046. We have provided both performance and fiscal oversight for the entire project, including our partner organizations, through reports, site visits, and financial reviews. This report provides details on our collaborative research into both manufacturing workforce training and assessment, and extending the lifecycle of alloy-based defense equipment through improved welding techniques. These research components address both defense industrial base capability gaps and defense systems engineering gaps. Statements of the problems studied and summaries of the most important results can be found in the Executive Summaries of our collaborative partner organization, including the Oregon Manufacturing Extension Partnership, The Pacific Northwest Defense Coalition, Portland State University, and Worksystems, Inc.. The detailed research data from each of our partners can be found in the appendices.

Oregon Manufacturing Extension P Executive Summary

In the spring of 2008, more than \$500K in U.S. Department of Defense funding became available to members of the Pacific Northwest Defense Coalition (PNDC) through DOD's \$2.5M Northwest Manufacturing Initiative. Recognizing the need of its member companies to implement Lean Manufacturing practices to increase efficiencies, eliminate waste, and curb costs, PNDC allocated just over \$233K of the funds to this purpose and partnered with the Oregon Manufacturing Extension Partnership (OMEP) to provide Lean Enterprise training and implementation services to member companies selected through a Request for Proposal process. OMEP is a member of the national U.S. Department of Commerce's National Institute of Standards and Technology Manufacturing Extension Partnership (NIST MEP), a leading provider of technical assistance to manufacturers nationwide.

To ensure most effective use of resources, PNDC selected for participation seven companies – all military suppliers – which had already demonstrated some level of commitment to continuous improvement and Lean. These companies were Allied Systems Company, Axiom Electronics, Columbia Helicopters, Inc., Northwest UAV, Timbercon, Inc., Tube Specialties Company, and Warne Scope Mounts. OMEP provided training in Lean principles and tools to employees at all levels within these companies and worked closely with company leaders and their designated Lean Champions to: 1) ensure successful implementation of production improvements and 2) develop an ongoing, sustainable culture of continuous improvement. OMEP's work with the companies substantially increased efficiencies, productivity, and competitiveness resulting in significant positive financial impacts as demonstrated by an independent survey administered through NIST MEP. The companies reported several millions of dollars in increased and retained sales, business investment and cost savings (aggregate results are provided in the final report). In addition, the increases in productivity and business growth resulted in the creation of 103 jobs and the retention of 98 more.

Pacific Northwest Defense Coalition Executive Summary

The Northwest Connector is an online database containing detailed profiles of Pacific Northwest companies across all industries at every level of the supply chain. The purpose of the tool is to link Northwest businesses to opportunities around the country via a robust, searchable online supplier database. The database contains detailed company profiles and includes fields that describe specific capabilities, products and services.

The NW Connector was created in partnership with Connector.com's creators San Diego East County Economic Development Council. **Connector.com Network - the United States Network** -- is the flagship project of the San Diego East County Economic Development Council. It began in San Diego's East County as a response to the defense/aerospace downturn and deep recession of the early 1990s. Since then, **Connector.com** has expanded to become the premier business-to-business information tool for the United States. The **Connector** focuses on primary industry/technology companies and their suppliers of goods and services. It combines the unparalleled speed and navigation capability of the Internet with a high quality company database that focuses on company capabilities and capacities at every level of the supply chain -- now powered by Google --all at no cost to the company.

Expansion from the San Diego region to the State of California began in mid-2002 with targeted emphasis on the aerospace and space industries and continues as we develop regional economic development partnerships throughout the state

The Northwest Manufacturing Initiative (NWMI) originally tasked the Pacific Northwest Defense Coalition (PNDC) with creating an inventory of defense manufacturing assets in the Pacific Northwest region. After conducting an Analysis of Alternatives, the PNDC identified the Connector as the best path for mapping the defense industry base. The Defense Logistics Agency had already invested heavily in the Connector, which meant that the expansion of the capability to the Northwest could be achieved at a fraction of the cost.

After its launch in 2009, the Northwest Connector has grown rapidly; listing a wide range of searchable profiles across a broad segment of industries. The Northwest Connector now has over 3500 companies between Oregon, Washington, Idaho, Alaska, Montana and Hawaii. The initial federal investment in the build-out of the Northwest Network has led to follow-on investments from state and local governments to promote the Connector as a way to cost effectively inventory local industry.

The success of the 2007 NWMI initiative has continued to reap benefits around the Northwest region. Numerous DoD components and prime contractors have used the Northwest Connector to identify potential suppliers and conduct market research activities as required by best practices in acquisition. Follow on federal investments have focused on continued capacity building, and the Connector is now poised to create new opportunities as a President’s budget program at the Defense Logistics Agency.

Portland State University Executive Summary

Plane strain fracture toughness, fatigue crack growth rates, and threshold stress corrosion cracking stress intensity levels were determined for ultrahigh strength corrosion resistant steels. Carpenter Technology C465 and Ferrium S53 steels have been compared to a baseline silicon modified 4340 (300M). Alloy 300M was evaluated after tempering at 400°F and 575°F, Custom 465 after aging at 950°F and 1000°F, and Ferrium S53 after double tempering at 934°F and then 900°F. Both alloys were heat treated using heat treatment parameters specified by Carpenter Technology. Electron microscopy confirmed tempered carbides in 300M and S53. C465 contained complex extremely fine precipitates. Compact tension(ASTM E399) sample geometries were used for toughness, fatigue crack growth and threshold stress corrosion cracking evaluation. Threshold stress corrosion cracking was done using the rising step load method with acoustic emission analysis added for crack detection, RSL). Property results are summarized below.

Alloy (Temper or Age)	K_{1c} (Ksi-in ^{1/2})	K_{1sc} (ksi-in ^{1/2}) (3.5wt%NaCl)	ΔK (ksi-in ^{1/2}) Threshold DaDn
300M (400°F)	55	15.5	6
300M (575°F)	60	18	6
S53 (935+900°F)	55	38	8
C465 (950°F)	75	21	12
C465 (1000°F)	120	34	9

The applicability of surfacing these alloys using electrospark deposition technology, (ESD) combined with Ultrasonic Impact Treatment (UIT) was evaluated. The effect of ESD on the heat affected zone,(HAZ), hardness, and

microstructure was determined. In order to develop ESD deposit hardness comparable to the substrate alloys, a Stellite 21 alloy electrode was used. Using a robotic deposition system with integrated UIT, the resulting HAZ was typically 10-15 microns in width. The width of the HAZ was established after the first ESD layer. After the first 3 ESD layers no further changes in the HAZ were observed. The HAZ hardness for each alloy was reduced within the 15micron wide HAZ.

UIT treatment increased the hardness of the ESD deposit, the HAZ, and the underlying substrate. Hardness levels up to HRC 60 were obtained. UIT also changed the ESD induced residual stress distribution from about +100ksi to -250ksi. This compressive stress extended well into the substrate while at the same time producing matching or increased hardness relative to the substrate. The cobalt based Stellite 21 with high levels of chromium results in a corrosion resistant deposit.

Fully reversed bending fatigue S/N curves of as deposited ESD and ESD post processed with UIT were conducted using tapered Krouse type specimens with a ½" square ESD divot filled with ESD. 20M cycles was used to determine runout. Cycle lives between 50,000 and 20M cycles were achieved. As deposited ESD with high tensile residual stress resulted in major fatigue debits compared to base metal S/N. UIT treatment resulted in major S/N curve improvement, approaching baseline for low and intermediate cycle tests and significantly improved high cycle behavior. Alloy 4340, HRC 53, was used as a baseline reference. ESD+UIT treated 4340 exhibited a S/N curve nearly equivalent to baseline for high quality deposits.

Worksystems, Inc. Executive Summary

Worksystems, Inc. (WSI) is a nonprofit organization serving the City of Portland, Multnomah and Washington counties. The mission of the organization is to build a comprehensive workforce development system that supports individual prosperity and business competitiveness.

The organizational values essential to the growth and vitality of the system include:

- A skilled workforce that improves business and individual competitiveness, earning capacity, income and assets.
- Partnerships that support alignment, effectiveness and continuous improvement.
- High standards of accountability to the community.

In pursuit of its mission, Worksystems:

- Provides a single point of focus for regional workforce efforts.
- Builds linkages between regional government, business, labor, education and other leaders to enhance regional workforce programs and services.
- Invests in education, community-based and industry partners to provide skill development and related services.
- Supports projects to foster innovation, expand best practices and encourage system change.
- Coordinates workforce development activities with regional business, economic development and education strategies.
- Evaluates system quality and outcomes.

To ensure a responsive, demand driven workforce development system, WSI regularly engages targeted industry businesses to inform regional workforce services and investments. WSI has extensive experience in managing highly regulated Federal and state resources. Through this experience WSI has policies, processes and procedures in place to ensure that funds are spent on allowable and appropriate trainings. There are also advanced data systems and management protocols in place for monthly and quarterly monitoring of contract expenditures and program goals.

Serving as the fiscal and administrative agent for the workforce component of the NW Manufacturing Initiative, WSI awarded ARL funding to 26 Pacific NW defense contractors to support training for their existing workforce. Training was completed in a variety of areas including: Leadership and Supervisory Training, Lean Manufacturing, Project Management, and technical skills training related to advancements in technology and engineering. All of these trainings are focused on streamlining processes, and increasing efficiency and effectiveness in either producing a more cost effective product or developing new products that support the defense industry. Several of these companies have expressed a need for additional training funds and new companies have requested training funds as well.

Appendix A – Oregon Manufacturing Extension Partnership Final Report



NORTHWEST MANUFACTURING INITIATIVE

FINAL REPORT

Submitted November 28, 2011

FOREWORD

In the spring of 2008, more than \$500K in U.S. Department of Defense (DOD) funding became available to members of the Pacific Northwest Defense Coalition (PNDC) through DOD's \$2.5M Northwest Manufacturing Initiative (NWMI), an earmark program designed to strengthen Oregon's defense manufacturing sector. The NWMI was intended to support research and development, worker training, and new manufacturing techniques, and to build the capacity of small businesses to participate in the defense marketplace.

Recognizing the need of its member companies to implement Lean Manufacturing practices to increase efficiencies, eliminate waste, and curb costs, PNDC allocated just over \$233K in funds to this purpose. PNDC partnered with the Oregon Manufacturing Extension Partnership (OMEP), to provide Lean Enterprise training and implementation services to member companies which would be selected through a Request for Proposal (RFP) process. OMEP, a not-for-profit team of manufacturing professionals and Lean Enterprise experts, is one of more than 400 MEP resource centers nationwide. The centers are part of the U.S. Department of Commerce's National Institute of Science and Technology (NIST) MEP program. OMEP's mission is to create a stronger Oregon economy by helping small to mid-sized manufacturers transform the way they do business and become more competitive in the global marketplace.

To roll out the project, PNDC and OMEP worked together to develop an application process, to notify member companies of the opportunity, and to hold a pre-proposal informational workshop. Companies submitted applications and seven companies were selected by the PNDC Board of Directors. To ensure the most effective use of resources, PNDC chose to help companies that had already demonstrated a commitment to continuous improvement and Lean Enterprise at some level. This would leverage the work accomplished and resources already expended by the companies. The ensuing report elaborates on issues addressed at each company and the services provided. It also includes aggregate results achieved by the companies in the areas of Increased/Retained Sales, Cost Savings, Business Investment, and Job Creation/Retention.

STATEMENTS OF PROBLEMS STUDIED

At a fundamental level, Lean Manufacturing focuses on eliminating waste in production and administration and on implementing continuous improvement practices that sustain and build upon initial improvements. Lean activities result in improved product quality, efficiency, and on-time delivery, reduced costs, enhanced productivity, increased competitiveness, and improved customer satisfaction. Consequently, military suppliers who adopt and implement these principles support and strengthen the military as a whole by providing high quality, reliable products in a timely fashion at competitive prices. While Lean Manufacturing and Continuous Improvement philosophies have existed in the marketplace for some time, few companies have been able to implement significant changes in the workplace without assistance. As mentioned in the Foreword, the goal of this project was to provide such assistance to military suppliers already committed to adopting Lean principles and to implementing improvements. Following are the issues addressed at each of the seven companies served.

Allied Systems

Allied Systems Company, located in Sherwood, Oregon is a fabricator of various types of equipment used by the wood products, petroleum, shipping, and farming industries, and cranes and winches used by the military. A competitor in the global marketplace, the company grew by acquiring product lines from other companies that served niche markets and capitalizing on its own engineering and manufacturing capabilities. While the product-diversification strategy helped to company to grow, it also presented challenges in these areas:

- Inefficient processes and systems on the shop floor and in the office/administration
- Inefficiencies in plant layout – designed departmentally rather than to enhance work flow
- Lack of a process or strategy to implement rapid change

To address the challenges, company leadership recognized the need to adopt and implement Lean Manufacturing Principles and Quick Response Manufacturing Techniques throughout the organization in order to ensure the company's ability to achieve and maintain projected growth.

NWMI funding allowed OMEP to work with the company to provide training in a variety of Lean topics, to use Group Technology methods to establish manufacturing cells for production efficiency, to develop internal Lean Champions, and to implement rapid response techniques. Training included, Principles of Lean Manufacturing, Value Stream Mapping, Cellular Manufacturing, Problem Solving, New Product Introduction, and Training Within Industry – Job Instruction. OMEP also provided Lean Accounting Principles coaching/mentoring to accounting/finance personnel to ensure that financial measures supported shop floor Lean implementation over time.

The Lean measures eliminated waste while improving efficiency, throughput, and on-time delivery. While the changes spread to other parts of the plant, activities were primarily focused on the military product lines. 24 individuals were trained directly – two of those are Lean Champions who have continued to sustain and expand on the gains since the project ended.

Axiom Electronics

Axiom Electronics' manufacturing services focus on high-reliability projects where quality results and timely delivery are the most important determinants of success. The company has a long history of providing mission-critical products to aerospace scientists and war fighters. This includes: 1) circuit boards in systems that track satellites, rovers and other space vehicles; 2) circuit boards on board satellites; 3) circuit boards on surveillance and attack aircraft; and 4) control boxes that make certain that all other systems work as intended. In addition to manufacturing products used in aviation, space and defense, Axiom provides turnkey materials services, engineering services, systems integration and configuration, testing services and the development of custom solutions.

Axiom applied for NWMI grant funding to help offset the costs for training and implementation of Lean Enterprise activities aimed at addressing these issues:

- Inflexible manufacturing systems/processes which were hampering the company's ability to meet a rising number of compressed lead-time jobs
- A lack of clear visibility identifying all inputs and required outputs for a job

OMEP's work with the company – primarily targeting military product lines but applicable throughout – included preliminary assessment of the current state, development of a project management tool clearly documenting all stages of product development as well as inputs and outputs, and training in “Breakthrough Thinking” for 11 employees, primarily engineers. The purpose for this training was to encourage employees to apply new and creative ways of looking at systems and processes. Although staff was familiar with the principles of Lean Manufacturing, they needed to be “unstuck” in their thinking before they could make the changes necessary to improve production efficiency. The training set employees on a course of “solution after next” thinking, solution selection, and implementation of Lean and problem-solving methodologies.

Columbia Helicopters, Inc.

Columbia Helicopters, Inc. (CHI) is the only operator of the commercial model Chinook - the Columbia Model 234 - and the commercial model Sea Knight – Columbia Vertol 107-II – helicopters in the world. The company's experience in fleet maintenance has enabled it to provide customers with unmatched, knowledgeable service based on years of global operational experience. CHI prides itself on the extensive maintenance services it provides to all branches of the U.S. Military as well as to Allied Military Operators.

At the time the NWMI funding became available, CHI had already begun its Lean journey with employee training and implementation projects that had demonstrated improvements in lead time and productivity attracting new business. With a success under its belt, the company wanted to tackle the difficult challenge afforded by its turbine engine repair process and turnaround time. CHI's ability to shorten this time while reducing repair costs would make the company considerably more competitive and serve to greatly increase their maintenance and flight operations business. CHI's turnaround time averaged 65 days while their primary competitor had a turnaround time of about 45 days; hence, CHI was under considerable pressure to make significant improvements in this area to retain and capture market share.

OMEP assessed the situation and addressed the issues by training 12 shop floor and administrative personnel and implementing changes, both, on the shop floor and in the office. Training included topics such as Principles of Lean Manufacturing, Value Stream Mapping, Set-up Reduction, Kanban, Problem Solving and Training Within Industry – Job Instruction. Shop floor changes consisted of applying cellular manufacturing techniques in the repair and maintenance areas, and on eliminating non-value-added processing in the office which contributed to lead-time delays. These efforts resulted in a 50% reduction in lead time and a substantial increase in business. Two of the training participants were groomed as Lean Champions who have succeeded in continuing to sustain and expand upon the improvements accomplished on this project.

Northwest UAV

Northwest UAV (NWUAV) is a multifaceted unmanned aerial vehicle (UAV) propulsion facility highly recognized for its skill, qualifications and reliability. A rapidly growing supplier of power systems for military and commercial Unmanned Air Vehicles (UAV), at the time of the project, the company was trying to double production output to keep up with growing customer demand. This was particularly challenging in light of the fact that their production facility was spread across three buildings. Management knew that the company needed to implement Lean Manufacturing to improve processes and systems, increase production capacity, and do a better job of meeting customer demand. Without Lean, they would not be able to expand their market reach and penetration nor achieve long term success of the organization.

OMEP provided training for all 15 company employees. Training topics included Introduction to Lean for Leaders, Principles of Lean Enterprise, Value Stream Mapping, 5S, Workplace Organization, Pull/Kanban Systems, and Training Within Industry – Job Instruction. In the implementation phase, OMEP worked with employees – including two Lean Champions – on the shop floor to implement improvements in small steps and to develop a roadmap for improvements over the long term. Because of the rapid growth in business and the physical layout of the facility, progress was slow but employees were able to begin to identify and take ownership of multiple improvement opportunities such as synchronizing assembly to engine break-in and test (thereby reducing assembly work in progress by 65%), and eliminating trips to inventory storage by implementing a Point of Use Storage System for low-value inventory items.

Timbercon, Inc.

Timbercon, Inc. is a product development and manufacturing company for fiber optic solutions – an industry leader in ruggedized fiber optic solutions for the defense/government, industrial, data storage, test & measurement, broadband telecommunications, medical, and networking industries. At the onset of the NWMI project, the company had averaged 20% annual revenue growth and added nearly 50 employees. Managing this growth and staying competitive in a rapidly expanding international marketplace was extremely challenging. One strategy they adopted to differentiate them from their offshore competitors was to grow and improve their business through quality certifications and initiatives such as AS9100, ISO 9001-2000, and implementing Lean Manufacturing. All of these initiatives were designed with the goal of better serving Timbercon's key customers while maintaining a United States based engineering and manufacturing floor.

In production, the company was particularly challenged by the need to restructure and achieve 5S optimization of their Military Production Line which was at or near capacity. To better meet the needs of their customers and to capture additional market share in this area of their business, they wanted to focus on making the changes that will help them improve overall quality, lead-time, and on-time delivery including expedited orders. Once Timbercon was awarded NWMI resources, OMEP helped the company to accomplish its goals for the Military Production Line through a combination of employee training and project implementation. Training topics included Principles of Lean Manufacturing, Value Stream Mapping, 5S Workplace Organization, and Problem Solving. OMEP complemented the training with coaching assistance throughout the course of identifying and implementing improvements to the Military Line. Overall, 60 employees participated in training and implementation activities.

Tube Specialties Co.

Tube Specialties Co. (TSCO), a supplier to military vehicle manufacturers, Freightliner / Daimler and Paccar, had been under a great deal of pressure by their customers to implement and sustain Lean practices. In response to the pressure, TSCO engaged OMEP in October, 2007 to gain assistance with their Lean transition. Employing the principles of Cellular Manufacturing, OMEP worked with TSCO to develop a Pilot Cell which, after several months' operation was deemed highly successful. The results to that point included lead-time reductions of 80% (from 2-3 **weeks** to 2-3 **days**) and productivity improvements of 30% as measured by units/lab hour.

With this first success under its belt, the company had made a good start on its road to a Lean transformation; however, the company found it was unable to build on the initial momentum and was at risk of backsliding – an option TSCO could not afford. The NWMI funds allowed OMEP to re-engage with TSCO to focus on developing work cells in additional critical production areas and to work with leadership to address issues related to company culture that were barriers to Lean progress. OMEP also continued working with the company's Lean Champions to further bolster their skills and efforts to sustain and grow Lean/continuous improvement activities internally. Training topics included Principles of Lean Manufacturing, Visual Controls, Setup Reduction, and Leadership in a Lean Culture. 30 employees participated in training activities.

Warne Scope Mounts

Warne Scope Mounts manufactures mount products for both sporting and tactical applications. Products include military and law enforcement rails and scope mounts, lasers, and flashlight mounts. Warne had been active in the local Lean community since 2001 and realized significant improvements in lead-time, quality and cost performance. The improvements resulted in very rapid growth (500% over 7 years). Warne expected the growth rate to continue with the introduction of new products, increased U.S. market share, and expanded distribution in Europe. The company reported the key to their expansion was the growth of the tactical products, particularly the laser mounting systems for the military M-16 rifles.

Even for a company with Warne's Lean experience, the rapid growth made it extremely challenging to maintain improvements and to identify additional improvements that could take the company to the next level. With the addition of new employees to support growth, the

discipline to train these individuals in Lean and to keep the organization focused on improvements was inconsistent leading to quality and lead-time issues that could have a detrimental effect on existing and future sales. Also, as the NWMI funding became available, the company had just successfully launched a barrel-mounted laser prototype resulting in numerous orders by the U.S. Army totaling thousands of units – DOD relayed demand was expected to grow to more than 3,000 units per month.

With the funding, OMEP was able to assist Warne in training up employees, improving and stabilizing production, and getting the company back on track with its Lean program. OMEP provided training to 35 people in Lean topics such as Lean Enterprise Essentials, Intro to Lean for Leaders, Value Stream Mapping, 5S Workplace Organization, Set-up Reduction, Visual Management and Standard Work. OMEP assisted employees with implementation of improvements on the shop floor, in administration, and on day-to-day Lean management systems. The efforts worked to stabilize production, increase product quality and improve lead-times.

SUMMARY OF RESULTS

To determine effectiveness of MEP Centers nationwide, NIST MEP conducts an independent survey of MEP manufacturing clients six months after project completion and annually thereafter for a period of three years. The survey includes impacts realized by the company in the areas of increased / retained sales, cost savings, company growth investments in workforce, technology, and equipment, and job creation / retention. The following impact data was collected on the seven projects outlined in this report and is provided in aggregate to protect the companies' privacy:

Increased Sales	\$ 12,755,000
Retained Sales	\$ 4,827,300
Cost Savings	\$ 7,127,000
Growth Investments	\$ 16,672,000
Jobs Created	103
Jobs Retained	98

Appendix B – Pacific Northwest Defense Coalition Final Report

PACIFIC NORTHWEST CONNECTORY

Northwest Connectory

**NWMI 2007: PNDC
Final Report**

PACIFIC NORTHWEST DEFENSE COALITION

NW Connectory Final Technical Report

Version 2 – October 20th, 2011

Last Revised by Brice Barrett

© Pacific NW Defense Coalition
2828 SW Corbett Ave • Suite 113
Portland, OR 97201
Phone (888) 701-7632 • Fax (503) 517-8095

Table of Contents

Introduction	1
Steps to Create a Profile	2
Profile Creation Tips and Tricks	3
Running Back End Searches	3
Appendix 1– Screen by Screen Description.....	4
Home	4
Create Profile	4
Reports.....	5
Company	6
Key Personnel.....	7
Address/Phone	7
Branches	8
Industry Codes	8
Facilities	9
Equipment.....	9
Capabilities.....	10
Staff Expertise	12
Proprietary/Protected	12
Certifications	13
Customer Base	14
Affiliations / Awards	15
Tracking.....	3
Profile User	3
Portal Info	3
Profile Control	3
Appendix 2 – Sample Confirmation Email	19
Appendix 3 – Information Sources	20
Appendix 4 - Summary of Connectory Related Outreach	21

Introduction

What is the Northwest Connector?

The Northwest Connector is an online database containing detailed profiles of Pacific Northwest companies across all industries at every level of the supply chain. The purpose of the tool is to link Northwest businesses to opportunities around the country via a robust, searchable online supplier database. The database contains detailed company profiles and includes fields that describe specific capabilities, products and services.

The NW Connector was created in partnership with Connector.com's creators San Diego East County Economic Development Council. The Connector was developed by ECEDC in the late 90's to catalogue the aerospace industry capabilities in California and promote those capabilities to other industries.

The Northwest Connector has over 3500 companies between Oregon, Washington, Idaho, Alaska, Montana and Hawaii.

The Northwest Connector can be accessed via www.nwconnector.com.

Features include:

1. Search functionality by keyword and categories. Including NACIS codes, industry type and location.
2. GIS mapping feature that displays each company on a map as a balloon.
3. Downloadable PDF maps, including Congressional districts and counties.

Steps to Create a Profile:

1. Log into admin.connectory.com
2. Verify Company does not have a Connectory Profile
 - a. Search using company name in “Company” Box.
 - b. Do not use single apostrophes.
 - c. Search using parts of the company name, incorporated names, etc
 - d. If already profiled check to make sure particular branch is the same, if not then profile the branch.
3. Create Blank Profile for company using “Create Profile” Link
4. Enter available info in to all appropriate sections, including:
 - a. Name, Year Established, web site, email, Employees, Industry Category, Elevator Speech, Key Personnel, Local Address, Phone, fax, NAICS Code(s), Unique Capabilities, Certifications, Customer Base, affiliations, Awards
 - b. Use recommended information sources for appropriate info.
 - c. If info can’t be found, continue creating profile. Critical elements of profile are name and contact info for company representative. We are only creating an initial profile for a company, then giving the tools needed to finish the profile.
 - d. See Appendix 1 for individual sections.
5. Once profile is complete, select “Profile User” link under Admin Tools.
 - a. Enter contact info for person at Company that will be responsible for profile.
6. Fill out Confirmation email
 - a. Use given templates
 - b. Enter in Company Contact email (same as in “Profile user” section). Also enter in Company Name, user name, password.
 - c. Modify the profile web link using the ConnectoryID number
7. Next select the “Portal Info” link under Admin Tools
 - a. Change Admin Authority to “Pacific Northwest, Portal – Northwest Network”
8. Go to “Profile Control” under Admin Tools
 - a. Change Profile Status to “Live”
9. Wait till following morning, then send out the Confirmation email.
 - a. The lag is intentional due to system indexing that takes place every night. This way a recipient will be able to see their profile come up under searches.

Profile Creation Tips and Tricks:

1. Connectory search results are generated using a Google search algorithm. Both the profile and the company web page are considered.
2. Include as much information as possible on the profile, but keep it visually organized.
3. Do not paste text directly from Word or web pages, unintended formatting can result. Use the remove formatting button if you do.
4. Use bulleting, bold, and underlining to format text after it has been imported to profile.

Running Back End searches:

1. Select "Reports" Link at top of home page
2. Select "Assets - Dynamic" option
3. Use the filter options to narrow down the dataset provided.
4. Select Report options/items
5. Select "View on Screen" to get a quick count/output
6. Select "Download Report" to get a Excel ready CSV file.
7. Open file in Excel and use as desired. Recommend resaving as an excel format file.
8. If other "fields" are desired, contact ECEDC for a custom report. They have the capabilities to query any field in the Connectory profile.

Appendix: Screen by Screen Description

Home Page:

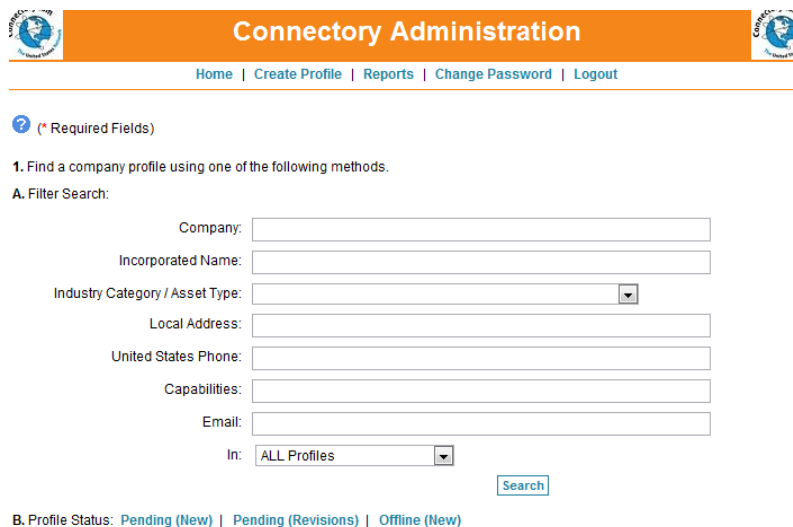

The screenshot shows the 'Connectory Administration' home page. At the top, there is an orange navigation bar with the title 'Connectory Administration' and several links: 'Home', 'Create Profile', 'Reports', 'Change Password', and 'Logout'. Below the navigation bar, there is a help icon and a note: '(*) Required Fields'. The main content area is divided into two sections: 'A. Filter Search:' and 'B. Profile Status:'. Section A contains several search criteria: 'Company', 'Incorporated Name', 'Industry Category / Asset Type' (with a dropdown arrow), 'Local Address', 'United States Phone', 'Capabilities', 'Email', and 'In:' (with a dropdown menu set to 'ALL Profiles'). A 'Search' button is located below these fields. Section B contains links for 'Pending (New)', 'Pending (Revisions)', and 'Offline (New)'.

1. Top bar contains the main navigation links.
2. Use the boxes to search for profiles prior to creating profile.
3. Do not use single apostrophes

Create Profile Page:

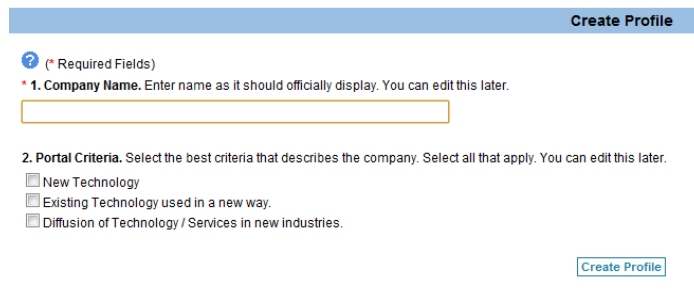

The screenshot shows the 'Create Profile' page. At the top, there is a blue header with the title 'Create Profile'. Below the header, there is a help icon and a note: '(*) Required Fields'. The main content area is divided into two sections: '1. Company Name' and '2. Portal Criteria'. Section 1 contains a single text input field for the company name. Section 2 contains three checkboxes: 'New Technology', 'Existing Technology used in a new way.', and 'Diffusion of Technology / Services in new industries.'. A 'Create Profile' button is located at the bottom right of the form.

1. Enter Company Name as desired. This name will show up on searches. This can be changed later in the "Company" page.

Reports:

(* Required Fields)

View and print ad-hoc and static reports.

1. Select Report:

Assets-Summary by Date Entered
Assets-Dynamic

2. Select Report Filter / Search:

Company:

Industry Category / Asset Type:

State:

Zip Code(s):
(example: 92009,92007,92109)

County:

NAICS Code(s):
(example: 423330,339920,336991)

Industry Sector:

Status:

3. Select Report Output / Results:

Company: <input checked="" type="checkbox"/>	Industry Category / Asset Type: <input type="checkbox"/>	Customer Base - Industry Sector: <input type="checkbox"/>
Year Established: <input type="checkbox"/>	Key Personnel: <input type="checkbox"/>	Certifications - Quality: <input type="checkbox"/>
Website: <input type="checkbox"/>	Local Address: <input type="checkbox"/>	Certifications - License: <input type="checkbox"/>
Local Employees: <input type="checkbox"/>	Mailing Address: <input type="checkbox"/>	Certifications - Ownership: <input type="checkbox"/>
Corporate Employees: <input type="checkbox"/>	United States Phone: <input type="checkbox"/>	Status: <input type="checkbox"/>
Annual Revenue: <input type="checkbox"/>	Industry Codes - NAICS: <input type="checkbox"/>	

4. Send Output:

View on Screen
 Download Report

[Feedback](#)

1. Ignore “Assets – Summary by Date Entered” Option since this runs queries on the entire Connectory Database including California. There is no way to separate out the information via the interface.
2. Use section #2 to filter the search
3. Section 3 allows some ability to dictate output into a .csv file or on screen.
4. Selecting NAICS codes, Certifications etc can result in a messy data set. Contact ECEDC if you want this data in a more manageable form.

Company:

test042511
Company

Ids)

ormation. Click the Save button.

* Company Name:

Incorporated Name:

Stock Symbol:

Year Established:

Web Site:
ex. http://www.connectory.com

Email:

Show Email on Profile:

Local Employees:

Corporate Employees:

Annual Revenue:

Industry Category / Asset Type:

Elevator Speech:

1. Company Name – This field is what shows up on searches as the name
2. Website – format needs to include “http://”
3. Email – recommend putting info@, sales@ etc
4. Select the show email on profile for generic emails or at request
5. Local employees - number at location or branch
6. Corporate employees – number of employees at parent company
7. Annual revenue – only put if company discloses
8. Industry category – select closest matching one for primary business function of company.
9. Elevator Speech – 3-4 sentences describing company. Ideally in 3rd person.

Key Personnel:

test042511
Key Personnel

? (* Required Fields)

Profile has been updated.

Enter Key Personnel. Click the Save button.

Display Order:

Prefix:

First Name:

* Last Name:

Title:

Email:

Show Email on Profile?

[Save](#)

Display Order	Prefix	First Name	Last Name	Title	Email	Show Email on Profile		
1		Jane	Doe	President	jane@test.com	<input checked="" type="checkbox"/>	Edit	Delete

1. Enter in 1-2 contacts. President, CEO, VP Business Development, Operations Manager, Sales Manager, Marketing Manager are all good entries.

Address / Phone:

Local Address

Address:

Suite, Unit or Apartment #:

City:

State:

Zip Code:

County:

Country:

HQ Address

Name:

City:

State:

Country:

Mailing Address

Same as Local Address

Address:

Suite, Unit or Apartment #:

City:

State:

Zip Code:

Country:

Phone Numbers

United States Phone:
ex. (999) 999-9999

Toll Free Phone:
ex. (999) 999-9999

International Phone:

Fax:
ex. (999) 999-9999

[Save](#)

1. Carefully enter address in "local address area". You might have to select save a few times to get the website happy with the entry. It checks against google maps and can be finicky.
2. If mailing address is same as local address, then simply check "Same as Local Address" box.
3. In HQ, list info for corporate headquarters, parent company etc.
4. Follow formatting exactly when entering in phone/fax

Branches:

(* Required Fields)

[← Back to Search Results](#)

Profile has been updated.

Enter Branch information. Click the Save button.

Name:

City:

State: ▼

Country: ▼

Name	City	State	Country		
test branch	bend	OR	United States	<input type="button" value="Edit"/>	<input type="button" value="Delete"/>

1. Enter in any branches of company, parent company branches etc.

Industry Codes:

test042511
Industry Codes

(* Required Fields) [← Back to Search Results](#)

Enter Industry Code information. Click the Save button.

NAICS Codes

Manual Code Entry

* NAICS

NAICS Codes Lookup

Enter up to 3 keywords or a 2-6 digit code (letters and/or numbers only - no special characters)

ex. 111, 111110, electric, electric contract, or electric contract services

NAICS	Description
<input checked="" type="checkbox"/> 332710	Machine shops
<input type="checkbox"/> 335211	Massage machines, electric (except designed for beauty and barber shop use), manufacturing
<input type="checkbox"/> 811412	Sewing machine, household-type, repair shops without retailing new sewing machines

NAICS	Description	
332710	Machine Shops	<input type="button" value="Delete"/>

SIC Codes

Manual Code Entry

* SIC Description

SIC Codes Lookup

Enter Keywords: (letters and/or numbers only)

All Words Any Words

NIGP Codes

* NIGP * Description

1. Only need to enter NAICS codes in. At least one. Multiple NAICS codes allowed and recommended.
2. Options of entering in codes manually, or searching by keyword.
3. Disregard SIC and NIGP Code areas

Facility:

test042511
Facility

? (* Required Fields)

[< Back to Search Results](#)

Enter Facility information. Click the Save button.

Total Facility Area: ▾

Functional Area:

B U | | Source

- clean room
- etc

1. Give basic descriptors of facilities, include any unique features.

Equipment:

? (* Required Fields) [< Back to Search Results](#)

Profile has been updated.

Enter the Equipment that the company uses to produce its products or services. Click the Save button.

Make Model Quantity ▾ Specs

Performance:

Make	Model	Quantity	Specs	Performance		
ACME	Widget Mark 2	5	double density	Handle parts 10' x 20'	<input type="button" value="Edit"/>	<input type="button" value="Delete"/>

1. List individually any important equipment.

Capabilities:

ation. Click the Save button.

Unique Capabilities:

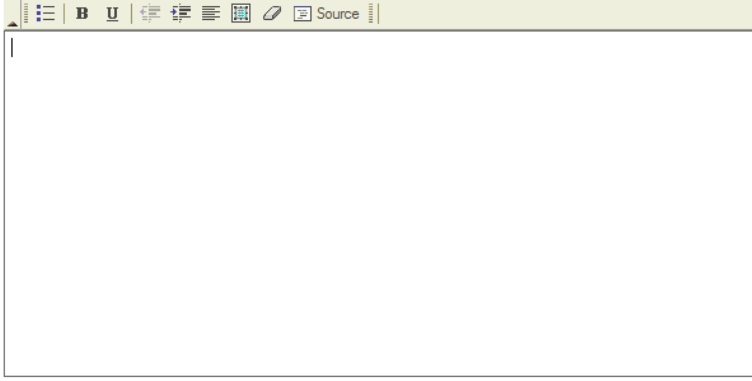

The screenshot shows a text editor window with a light green header bar containing a menu and icons for Bold (B), Underline (U), and Source. The main area is a large, empty white box. A small blue 'Save' button is located at the bottom right of the editor area.

1. Unique Capabilities section
 - a. Main area to fill out for each company
 - b. Recommend that capabilities are listed out in bullet form.
 - c. Can chose to list equipment, facilities, etc here as well.

Applied Technologies:

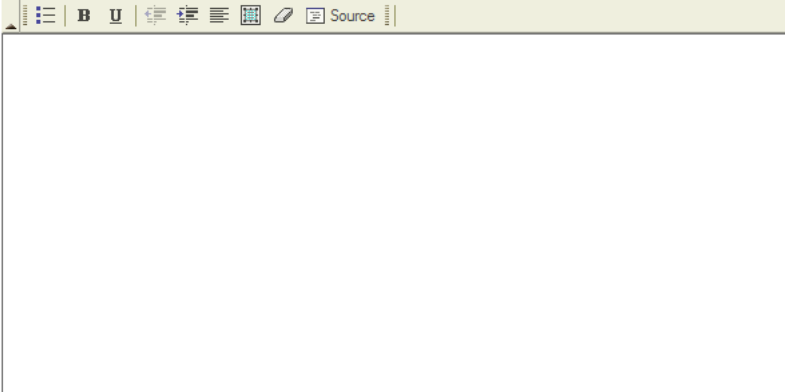

The screenshot shows a text editor window with a light green header bar containing a menu and icons for Bold (B), Underline (U), and Source. The main area is a large, empty white box. A small blue 'Save' button is located at the bottom right of the editor area.

2. Applied Technologies
 - a. Secondary section that can be used if desired. Focus on technology offered that is created by other companies.
 - b. Examples could be a trademark system that a construction firm employs in their work.

Special Materials / Capabilities:

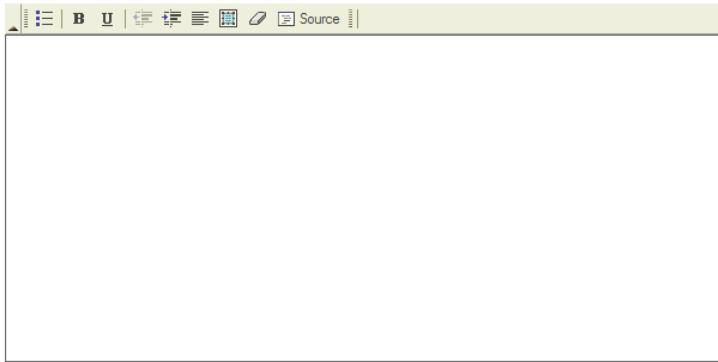

The screenshot shows a rich text editor with a toolbar at the top containing icons for list, bold, italic, link, unlink, bulleted list, numbered list, link, and source. The main text area is empty. A 'Save' button is located at the bottom right of the editor.

Save

3. Special Materials / Capabilities

- a. Examples could be : titanium, inconel, carbon fiber etc

Save

Collaboration / Partnering Opportunities:

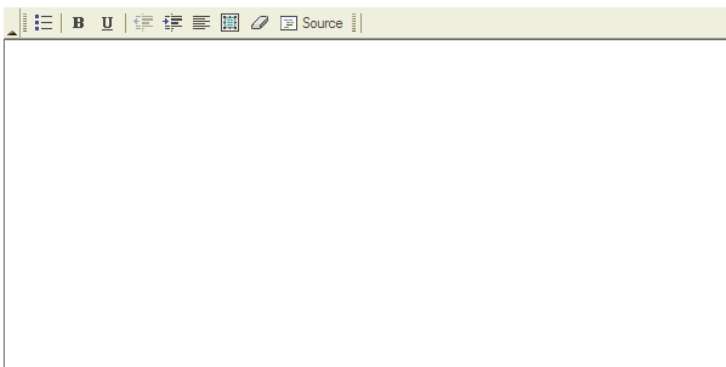

The screenshot shows a rich text editor with a toolbar at the top containing icons for list, bold, italic, link, unlink, bulleted list, numbered list, link, and source. The main text area is empty. A 'Save' button is located at the bottom right of the editor.

Save

4. Collaboration / Partnering Opportunities

- a. Fill out if information is provided by company

Staff Expertise:

Enter information. Click the Save button.

Technical Areas:

Educational Background:

Experience:

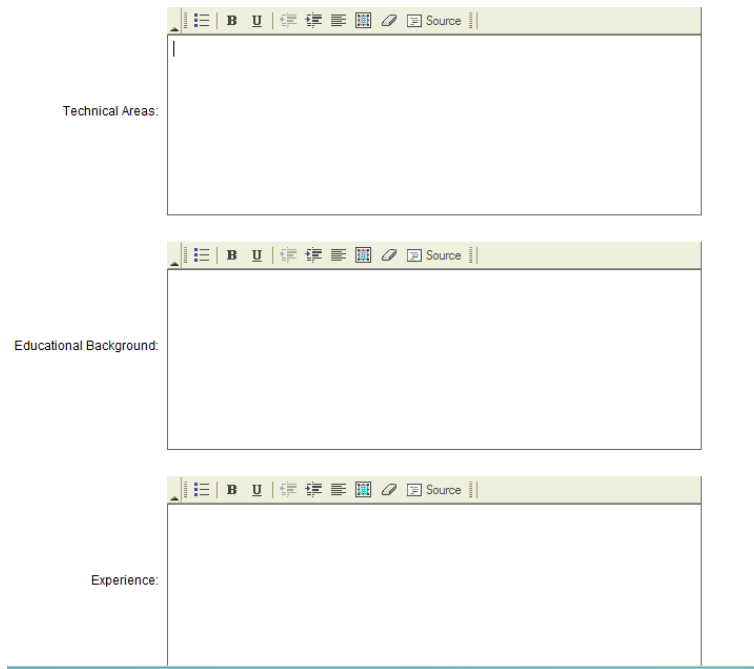

The Staff Expertise section can be used, but is typically left to the company to fill in. It can be used to showcase any significant talent on staff to compliment the capabilities section.

Proprietary/Protected:

Proprietary Products

Proprietary Products:

Save

NONE

Other Lines (Third Party Products)

Lines Carried:

Save

NONE

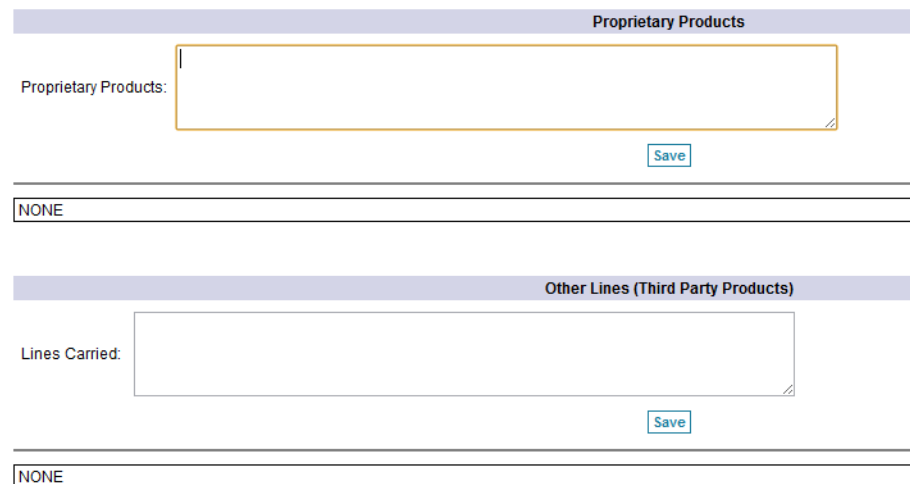

Leave this section empty. It does not show up on a visible profile.

Certifications:

Quality Certifications				
Certifying Agency	Certification	Other	Number	
<input type="text"/>	<input type="text"/>	<input type="text"/>	<input type="text"/>	
<input type="button" value="Save"/>				
Certifying Agency	Certification	Number		
	AS9100		<input type="button" value="Edit"/>	<input type="button" value="Delete"/>
	ISO 9001		<input type="button" value="Edit"/>	<input type="button" value="Delete"/>

Quality Certifications such as AS9100, ISO etc.

- List Certifying Agency and number if available.
- Select Certification from drop-box or manually enter in "Other".
- If there is text in "Other", that text will override the drop-box.

License Certifications				
Certifying Agency	Certification	Other	Number	
<input type="text"/>	<input type="text"/>	<input type="text"/>	<input type="text"/>	
<input type="button" value="Save"/>				
Certifying Agency	Certification	Number		
State of Oregon	CCB	123456	<input type="button" value="Edit"/>	<input type="button" value="Delete"/>

License Certifications such as Contractor numbers.

- Same rules as in Quality.

Owner Certifications				
Certifying Agency	Certification	Other	Number	
<input type="text"/>	<input type="text"/>	<input type="text"/>	<input type="text"/>	
<input type="button" value="Save"/>				
Certifying Agency	Certification	Number		
	Service Disabled Veteran Owned Business (SDVOSB)		<input type="button" value="Edit"/>	<input type="button" value="Delete"/>
DLIS	CCR	CAGE # 12D34	<input type="button" value="Edit"/>	<input type="button" value="Delete"/>

Owner Certifications including SDVOSB, HUBZone, Minority

- Same rules as in Quality.
- Many of the certifications are still California Based so use "Other" box.

Customer Base:

 (* Required Fields)

Enter Customer Base of the company. Click the Save button.

Description:

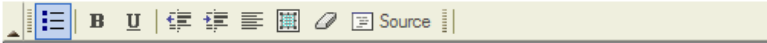

- Boeing
- Raytheon
- Lockheed Martin
- Etc

[Save](#)

List any significant details about the company customer base. Major clients can be listed if they are publicly stated on the website or given by company.

Industry Sectors

Industry Sector:

[Save](#)

Industry Sector	
Aerospace	Delete
Defense/Military/National Security	Delete
Manufacturing	Delete
Space Enterprise	Delete

Geographic Areas

Geographic Area:

[Save](#)

Geographic Area	
Worldwide	Delete

List the typical industry sectors that the company serves and the geographic area it focuses on.

Affiliations and Awards:

Enter Affiliations and Awards of the company. Click the Save button.

Affiliations:



- Pacific Northwest Defense Coalition (PNDC)
- Pacific Northwest Aerospace Alliance (PNAA)
- etc

Awards:

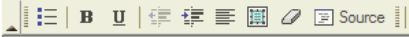

- SBA Small Buisness of the Year

[Save](#)

1. List in bullet form any affiliations and awards.
2. When listing organizations, list both the title and the acronym.
 - a. Ex: Pacific Northwest Defense Coalition (PNDC)

Profile Tracking:

Tracking Revisions: Add

Summary:

Last Revision Date: ex. 01/01/2000

Contact Source: ▼

Approved By:

Other (for Contact Source):

Via: ▼

Source Description: ▼

Contact:

Other (for Source Description):

Phone: ex. (999) 999-9999

Email:

Revisions Made:

Entry Date/Time	Summary	Approved By	Last Revision Date	
05-17-2011 1:52 PM	Added Company info	PNDCNav		<input type="button" value="View"/>

Use section to keep track of any changes made to profile, especially company requests. When company asks for profile to be removed, make a note in this section.

Profile User:

test042511
Profile User

 (* Required Fields)

ConnectoryID: 29033

First Name:

Last Name:

Email:

Phone:
ex. (999) 999-9999

* Login Name:

* Password:

Disclaimer Email Address:	(no email address available)	<input type="button" value="Send Disclaimer Email"/>
Login Email Address:	(no email address available)	<input type="button" value="Send Login Email"/>

1. Put all available contact information for Company contact in appropriate boxes.
2. Take the ConnectoryID #, Login Name and Password for use in Confirmation Email.
3. Email listed is used by system for yearly checkup email.

Portal Info:

Admin Authority. Select the Portal Partner assigned to manage this asset.

Admin Authority:

Portal Criteria. Select the best criteria that describes the company or organization. Select all that apply. Click the Save button.

- New Technology
- Existing Technology used in a new way.
- Diffusion of Technology / Services in new industries.

Portal Assignment. The portal(s) to which this company belongs.

<input type="checkbox"/>	California
<input type="checkbox"/>	California Aerospace
<input type="checkbox"/>	California Green
<input type="checkbox"/>	CIC Innovation Asset Mapping Inventory
<input checked="" type="checkbox"/>	Northwest Network
<input checked="" type="checkbox"/>	Oregon
<input type="checkbox"/>	San Bernardino
<input type="checkbox"/>	San Diego
<input type="checkbox"/>	San Diego East County
<input type="checkbox"/>	Southwest California

1. Assign profile to appropriate Admin Authority. For NW Connectivity companies that is “Pacific Northwest Portal – Northwest Network”
2. Criteria is just for Innovation project, disregard.
3. Portal Assignment is done automatically by system based on local address.

Profile Control:

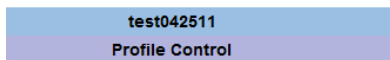

* Required Fields)

Profile Status:

1. Any new profile is created as “Offline (New)”.
2. Change Status to “Live” to make profile accessible to public.

Appendix 2: Sample Confirmation Email Text

Company Name – Welcome to NWConnectory.com — the Northwest

The **Pacific Northwest Defense Coalition (PNDC)** in partnership with the **Oregon Business Development Department (OBDD)** is pleased to introduce to you to NWConnectory.com – the **Northwest Connector**, an **award-winning** business-to-business and **economic development resource**.

PNDC, in cooperation with the OBDD, Portland Development Commission, the Pacific Northwest Aerospace Alliance and the Washington State Department of Commerce have engaged the founders of Connectory.com, the San Diego East County Economic Development Council, to develop a Northwest Network Portal. The Northwest Connector, hosted on Connectory.com, will focus searches on companies located in the Pacific Northwest and provide relevant business resources, economic development data, and government contracting information.

In-depth Northwest Connector Profiles are custom-built and tailored specifically to your business' products, services, technologies, capabilities, and/or capacities.

The [Northwest Connector](#) is a **no-cost** online buyer-supplier network that provides:

- Powerful means for government, large company, and institutional buyers to identify sources of products, services, technologies, capabilities, and capacities
- Detailed capabilities and capacities for companies at every level of the supply chain
- Focus on manufacturing/technology companies and their supplier chain including wholesalers/logistics, technical services, construction, agribusiness, and mining
- A unique way to connect with companies and other assets by understanding their capabilities
- And much more—click [here](#) to view California success stories!

The Connector began in California and recently expanded across the United States. The **Northwest Connector is funded by** the Pacific Northwest Defense Coalition, the Defense Logistics Agency (DLA) and other public and private stakeholders. This substantial public sector investment means there is **NO COST** or **FEE** associated with the Connector or your participation.

How to Get Started:

1. **Please reply to this email to acknowledge your receipt and review of this confirmation.**
2. Please review your profile to verify its accuracy by clicking on the following link:
http://connectory.com/search/profile_view.aspx?connectoryId=2
3. Make changes to your profile in one of two ways:

A. Set up your account so may edit and expand your profile personally

- Go to the Connector Member Page by clicking [here](#)
- Us the **temporary user ID and password** provided below to access your account:

Temporary User Name:

Password:

B. If you do not wish to set up an account but would like to make changes to your profile, you may:

- call us at 1-888-701-7632 ext. 104
- fax us at (503) 517-8095, or
- reply to this email with the correct information.

If you wish to have your no-cost Connectory.com profile removed, please click [here](#) or reply to this email with the subject "unsubscribe."

Appendix 3: Useful Information Sources

1. Defense Logistics Information Service – BINCS
 - a. <http://www.dlis.dla.mil/bincs/>
 - b. This is a good site to look up company CAGE Codes.
2. SBA – Dynamic Small Business Search
 - a. http://dsbs.sba.gov/dsbs/search/dsp_dsbs.cfm
3. State of Oregon’s Corporation Division Business Name search
 - a. http://egov.sos.state.or.us/br/pkg_web_name_srch_inq.login
4. State of Washington Corporations Division Search
 - a. http://www.sos.wa.gov/corps/corps_search.aspx

Appendix 4: NW Connectory Major Outreach Summary

For file references below, refer to the accompanying compressed file with numbered files

Summary of all NW Connectory related activities – May 25th, 2011

Since going live in January of 2010, the Northwest Connectory has grown to include nearly 4,000 companies in 6 states.

Breakdown by State:

- Alaska = 8
- Hawaii = 12
- Idaho = 21
- Montana = 22
- Oregon = 1852
- Washington = 1876

Profiling was done by Justin Jangraw, Navindra Gunawardena and ECEDC Staff. Justin Jangraw profiled PNDC companies. In addition to directly creating profiles, Navindra focused on obtaining lists of companies from partners, and then worked with ECEDC staff to have those lists profiled.

Sources of lists include:

- Oregon Business Development Department
- Portland Development Commission
- Pacific NW Aerospace Alliance
- Northwest Environmental Business Council
- Oregon Solar Energy Industry Association
- SBA Dynamic Small Business Search database
- Oregon Wave Energy Trust

- Oregon Manufacturing Extension Partnership

A Connectory profile intake form was created and distributed. That was used by companies to directly send in information which was then used to create a profile. See included file A1.

Paid Sponsorships were given by both the Oregon Business Development Department (OBDD) and Portland Development Commission (PDC). The OBDD sponsorship paid an Oregon specific portal within the NW Connectory, as well as hiring Navindra Gunawardena as a project manager for entering companies into the database and promoting the database.

PDC contributions paid for the creation of custom printed marketing materials for the NW Connectory including:

- Pens
- Mugs
- Mouse pads
- Promotional Folders
- Marketing handouts
- Sticky Notes
- Trade show booth panels
- Pop-up banners

Brice Barrett and Navindra Gunawardena promoted the NW Connectory at numerous events including networking sessions, conferences and trade shows. Highlight of events:

- Oregon Economic Development Association – Spring 2010 meeting
- Oregon Economic Development Association – Fall 2010 meeting
- NEBC Future Energy Conference – March 2010
- NEBC Future Energy Conference – March 2011
- Alliance 2010
- Alliance 2011
- PNDC Bremerton NW Defense symposium

- American Wind Energy Association (AWEA) Trade Show – May 2010
- AWEA small wind trade show
- Navy Goldcoast
- PNAA conferences in 2010 and 2011

Promotions include presentations and trade show booths.

Steering Committee for guiding the NW Connectory was setup in Summer of 2010. Included members from OBDD and PDC. Purpose was to include partners and build a committee to advise and guide direction of Connectory. Meetings were held monthly in from June 2010 till Dec. 2010. See meeting minutes. See files A2 – A5.

NW Connectory Electronic newsletter was created using Constant Contact. Was sent out in Feb. 2011, Dec. 2010 and Oct. 2010. See Files A6 – A8.

Success Stories (see printed materials):

- Vigor and Applied Filter technology partnership
- Lockheed vetting Last US Bag
- See files A9 and A10

Representation of Large companies in Connectory proposal – See File A11

Oregon Key Industries and the NW Connectory Document – This is an analysis done by Navindra of Oregon companies in the NW Connectory. The focus is the distribution of companies along Key industries defined by the Oregon Business Development Department. See File A12 for more details.

Connectory Search report – This report was an analysis of how the search capabilities behaved when searching for multiple Zip or NAICS codes. Changes to the search features were proposed at the end of the report. See File A13.

Other included files of interest:

- A14 – Abstract submitted for AWEA 2011 show
- A15 – NW Connectory Presentation
- A16 – OBDD Training Presentation

APPENDIX 4: Reference File A1 – Connectory Intake Form

NWConnectory.com
Northwest Network Profile Intake Application

Name of Company (your dba – how you want to be listed) _____

Elevator Speech (brief, 2-3 sentence, description of the company's services and/or products.)

Address: _____
City _____ Zip _____ County: _____

Local Telephone _____ Fax _____ Voice/800 _____

Mailing Address (if different from street address) _____

Corporate Headquarters (if different. City/County/State Only) _____

Branches – (City/ County/State Only, if applicable) _____

Contact E-Mail _____ Website URL _____

Key Personnel (Include titles. Need at least one contact)

	First Name	Last Name	Title*	Email
1				
2				

*Principal/Owner/ President ; Vice-President/Manager/Chief Technical Officer; Sales/Marketing/ Communications; etc.

NAICS Code – list all that apply:

Year Established _____

Number of (local) Employees _____

Annual Revenues _____

Capabilities, Processes, Materials, Applied Technologies. Describe capabilities, special processes, applied technologies, techniques and materials. (list form)

Proprietary Products and Technologies. List/describe those products, product lines, and/or technologies that are identified with your company (i.e., sold under your brand name).

Return Completed Forms to:

Navindra Gunawardena, Connectory Project Manager

Fax: (503) 517-8095; email: Navindra@nndc.us; 2828 SW Corbett Ave Suite 204, Portland OR 97201

APPENDIX 4: Reference File A2 – June Committee Minutes Revised 091010

NW Connectory Steering Committee Meeting Minutes

June 16, 2010, 3-4:30 pm

Business Oregon Portland Office, PDX 4 Conference Room

121 SW Salmon Street, Suite 205

Portland, OR 97204

ATTENDANCE:

- Brice Barrett
- Rick Williams
- Pam Neal
- Marian Hammond
- Sarah Miller
- Navindra Gunawardena

I. INTRODUCTION – BRICE BARRETT

- Purpose of meeting is to setup a small committee to oversee NW Connectory, including resources, stakeholders, local gov. outreach, state outreach.
- Rick asked about wave energy trust involvement including connectory in Indiana and New Jersey

II. CONNECTORY STATUS UPDATE – BRICE AND NAVINDRA

- Updated Oregon Profile Count Breakdown
 - I. 1005 companies in database
 - I. 706 live profiles
 - II. 299 offline profiles
 - II. Of the 299 offline profiles
 - I. 141 are from active wear cluster list
 - II. ~20-30 are large companies (ex. Intel, Nike, Vestas, etc)
 - III. Others are companies without a contact email address

Action Item: Get wave energy infrastructure report from Rick (Navindra)

- Navindra outlined process of dealing with lists of companies
- Brice updated overall Connectory Plan
 - I. 40k potentially for updates
- Brice outlined grant for regional innovation clusters
 - I. Predominantly SDSU work
 - II. Could improve GIS mapping feature
 - III. Cluster mapping and innovation mapping
 - IV. \$1-1.5M
 - V. Renewable energy cluster for NW highly likely
 - VI. Know more by Oct.
 - VII. OIT potential State partner for energy cluster work
- Brice presented change management for Connectory
 - I. Outlined to ECEDC in email by Brice
 - II. Positive initial response from ECEDC
 - III. Release notes for updates

- IV. Formal engineering change process. Timeline, scope, cost.
 - I. Summer 2010
- V. For major future releases, systematic access to test env.
 - I. To be addressed soon
- VI. Status update from ECEDC by June 30th.
- VII. Rick commented that we should get a member on the configuration control board for Connectory. Find out if ECEDC has such a board. Also have a mechanism for Bug Tracking

Action Item: Report to Committee on June 30th status update (Brice)

Action Item: Send Pam Neal the Tim McCabe Email (Navindra)

- AWEA. Oregon/Washington Delegation went to AWEA in Dallas. Had live Connectory Demo.
 - I. General sentiment was that Connectory Presence was beneficial, but Live demo was not.
 - II. Need marketing materials for Connectory
 - III. Potential for presenting paper at next year's AWEA

Action Item: Discuss paper at next year's AWEA (Brice and Pam)

II. Connectory Steering Committee discussion

- Mission
 - I. Steering committee guides PNDC director and staff. Ensures we are serving all stakeholders and provide new ways of connecting with new stakeholders. – Brice
 - II. Provides Ownership to stakeholders and regional partners. Means of growing regional ownership. – Marian
 - III. Will the Committee be just for Oregon? Brice and Rick suggested that committee be primarily Oregon to start, expand to other areas as significant stakeholders come on board.
 - IV. Subcommittees?
 - V. Have different levels, advisory, core, etc.
 - VI. Core steering committee composed of members that have a significant vested interest.

Action Item: Draft Charter (Brice and Navindra)

- Structure and composition
 - I. 5-7 people
 - II. Navindra is staff of committee. Will take notes, manage action items and committee.
 - III. Potential for geographical subcommittees in the future
 - IV. Have subset for talking technical oversight issues – Sarah

Action Item: Sub-committee for technical oversight issues (Sarah and Rick)

- Short and Long term goals
 - I. widespread adoption by important public and private players in the short term - Brice
 - II. In the long term, how is funding kept without congressional earmarks? – Brice
 - III. Currently in development phase, transition to use phase
 - IV. Increase awareness of system and coverage – marian
 - V. Explore potential plateaus in long term issues – rick

- VI. Create vision of ideal system, create ToBe Map for long term improvement – Navindra
- Committee needs to have Program management review with ECEDC. Perhaps 2 hour teleconference format.
- Committee involvement in negotiations of MOU
- Need to be prepared for CIO level questions – Rick
- Meet quarterly

Action Item: Setup next meeting (Navindra)

- PDC – keep Kevin and Pam on committee list.

III. Connectory Outreach

- PDC proposal sent by Brice for Marketing proposals
 - I. Schwag, brand exposure. Magnets etc
 - II. Get in front of people for promoting use of Connectory

Action Item: Conversation on Connectory Road Show (Brice and Marian)

Action Item: PDC proposal status to Brice (Pam)

- Long Term Strategy - Build up success stories
 - I. How will success stories be done?
 - I. Connectory Blog
 - II. Newsletter
 - II. Campaign for getting NW Connectory logo/link on other sites - Rick
 - III. MBA program presentations – educational aspect – Rick
 - I. OEMBA, Willamette, PSU, U of P, Marylhurst, etc
 - II. Resource for Students doing research
 - IV. Economic development outreach
 - V. NAICS code distribution of profiles
 - VI. ACT database
 - VII. Tracking traffic, monitoring nw connectory

Action Item: Generate Distribution of Profiles by NAICS codes (Navindra)

Action Item: Connect with Sarah about ACT database, by 6/25 (Navindra)

Action Item: setup blog by next meeting (Navindra)

Action Item: Think about tracking traffic on nwconnectory and oregon4biz (Brice)

Action Item: send report to Brice on oregon4biz connectory traffic (Sarah)

Action Item: Newsletter (Navindra)

Action item: query sources for success stories (everyone)

Action item: send out agenda 2 weeks prior to next meeting (Navindra)

IV. Action item review

V. Meeting Adjourned

APPENDIX 4: Reference File A3 – September Committee Minutes 091010

NW Connectory Steering Committee Meeting Minutes

September 1, 2010, 11-12:00 pm

PNDC, Fountain Conference Room

2828 SW Corbett Ave

Portland, OR 97201

ATTENDANCE:

Brice Barrett, Marian Hammond, Sarah Miller, Rick Williams, Kevin Johnson, Pam Neal, Navindra Gunawardena.

I. CALL TO ORDER, REVIEW AND APPROVAL OF MINUTES– BRICE BARRETT

- Brice Called meeting to order
- Committee reviewed minutes from June Meeting
- Sarah asked for addition of action item to setup subcommittee for technical oversight issues. Placed as action item 17 in list below.
- Rick asked that “conf. control board” be changed to “configuration control board”
- Brice motioned to approve minutes with requested changes, Sarah Seconded the motion and the committee approved the minutes.

II. ACTION ITEM REVIEW FROM JUNE MEETING

#	Action Item	Responsible Party	Current Status
1	Get wave energy infrastructure report from Rick	Navindra	In Progress. Working with OWET to get companies in
2	Report to Committee on June 30 th status update	Brice	In Progress
3	Send Pam Neal the Tim McCabe Email	Navindra	Done
4	Discuss paper at next year’s AWEA	Brice, Navindra, Pam	In progress
5	Draft Charter	Brice and Navindra	Done. Part of agenda
6	Setup next meeting	Navindra	Done
7	Conversation on Connectory Road Show	Brice and Marian	In progress
8	PDC proposal status to Brice	Pam	Done
9	Generate Distribution of Profiles by NAICS codes	Navindra	In Progress
10	Connect with Sarah about ACT database	Navindra	Done
11	setup blog by next meeting	Navindra	In progress
12	Think about tracking traffic on nwconnectory and oregon4biz	Brice	In progress
13	Send report to Brice on Oregon4biz Connectory traffic	Sarah	Done
14	Newsletter	Navindra	In progress
15	Query sources for success stories	Everyone	In progress

16	Send out agenda 2 weeks prior to next meeting	Navindra	Done
17	Establish sub-committee for technical oversight issues	Sarah and Rick	In progress

- Changing #1 to Working with OWET to get companies in Connectory
- Action item #2 – Brice to give out ECEDC response to version control by Sept. 8th
 - I. Comments to be returned to Brice within two weeks of receipt.
- Removing items #3, 5, 6, 8, 10, 13, and 16 from action item list due to completion.
- #4 – Pam gave update that paper abstract is due by 20th.
 - I. Rick gave idea of 3 different papers: Supply chain, metro and state support/incentives, and information system aspects
- Paper on Key Industry/NAICS analysis presented.
 - I. Navindra agreed to send simplified version of charts and presentations to Marian
- Query of sources made a standing agenda item, removing #15 from list

III. CONNECTORY STATUS UPDATE – BRICE AND NAVINDRA

- Marketing Materials on order. Folders and Trade show booth are done. Brice will send picture of booth after meeting.
- 1380 Oregon profiles in database, 858 live.

Action Item: Navindra will send Sarah a profile strategy report, detailing remaining profiles to be made live and profile lists to be worked.

Action Item: Develop plan to provide feedback on opt-out companies.

- Add discussion to source code escrow in case ECEDC stops supporting Connectory

IV. BUSINESS OREGON UPDATE – SARAH AND MARIAN

- State budget in progress
 - I. Like to use Connectory as tool to promote value of OBDD
- Need rigorous methodology for tracking results
 - I. How to track
 - II. How to monetize?
 - III. Need direct outcome to business

Action item: Success stories to OBDD by Oct. 1st, 1 week earlier preferable – everyone

Action Item: Brice to investigate Email blast/Survey to NW Connectory

- IV. End result focused – sales
 - Need to do statewide outreach to promote Connectory usage.
 - I. OEDA

Action Item: Work with OBDD to identify Key Contacts at local Economic development groups to promote Connectory. – Navindra, Brice, Sarah, Marian

V. PDC update – Pam and Kevin

- Several upcoming events at PDC that can have a Connectory presence

Action Item: Navindra to work with Pam on setting up a Connectory presence at upcoming PDC events.

Action item: Cover all bases for capturing different links, including www.northwestconnectory.com – Brice

VI. DRAFT CHARTER

- Handout in folder – work in progress
- What are the investment levels to get a voting seat on committee?

Action item: Develop Committee policy on membership – Brice

VII. Around the Table

- Next meeting around Oct 1st, 1 hour. Set meetings to occur monthly for the near future.

VIII. Meeting Adjourned

APPENDIX 4: Reference File A4 – October Committee Minutes 102010

NW Connectory Steering Committee Meeting Minutes

October 13, 2010, 1-2:00 pm

PNDC, Fountain Conference Room

2828 SW Corbett Ave

Portland, OR 97201

ATTENDANCE:

Karen Goddin, Rick Williams, Kevin Johnson, Pam Neal, Navindra Gunawardena, Molly Hefeneider

I. CALL TO ORDER, REVIEW AND APPROVAL OF MINUTES– NAVINDRA

- Navindra called meeting to order
- Committee reviewed minutes from September Meeting
- Approval postponed till November meeting due to lack of quorum.

II. ACTION ITEM REVIEW FROM JUNE MEETING

#	Action Item	Responsible Party	Current Status
1	Working with OWET to get companies in Connectory	Navindra	In Progress.
2	ECEDC Version Control and Change Management Response	Brice	In Progress
3	AWEA 2011 Paper Abstract	Brice, Navindra, Pam	Done
4	Connectory Road Show	Brice and Marian	In progress
5	Generate Distribution of Profiles by NAICS codes	Navindra	In Progress
6	setup blog	Navindra	In progress
7	NW Connectory Traffic	Brice	In progress
8	Newsletter	Navindra	In progress
9	Establish sub-committee for technical oversight issues	Sarah and Rick	In progress
10	Profile Strategy Report	Navindra	Done
11	Connectory Email Blast	Brice	In Progress
12	Capturing different links, including www.northwestconnectory.com	Brice	In progress
13	Committee Policy on membership	Brice	In progress

- Removing #3 and #10 from list due to completion

III. CONNECTORY STATUS UPDATE –NAVINDRA

- Marketing Materials were received. Now have mugs, pens, post-its and mouse pads for NW Connectory promotion.
- Navindra took Connectory trade show booth and marketing materials to OEDA annual meeting
- 1643 Oregon profiles in database, 925 live.
- First NW Connectory Newsletter sent out Monday 10/11
- Connectory Road Show
 - I. Meet with key community economic development contacts to promote connectory
 - II. Karen brought the possibility of hosting a webinar for companies
 - III. Present Connectory at a session of the Oregon Business Leadership summit
 - I. Rick made introduction to Oregon Business Council.
 - IV. Connectory was well represented at OWET Wave conference
 - V. Engage Energy Trust for Connectory use.
 - I. **Action Item: Contact Margie Harris at Energy Trust.**

IV. PDC update – Pam and Kevin

- NWIA supply chain event is now Jan 12 and 13th
- Small Wind Conference booth will have NW Connectory materials
- Promote Connectory at Nov. Manufacturing lunch
- Cluster events are coming up in Nov. and Dec. that could be good venues for Connectory promotion.
- Rick proposed during this discussion that promotion kits could be created, each of which can be sent out to an event. Includes Pop-up banner, marketing materials. Create several, and loan out so that we can expand coverage.

V. BUSINESS OREGON UPDATE – KAREN

- Nothing further from OBDD

VI. Around the Table

- Next meeting will be mid November.

VII. Meeting Adjourned

APPENDIX 4: Reference File A5 – December Committee Minutes 122210

NW Connectory Steering Committee Meeting Minutes

December 6th, 2010, 1-2:00 pm

PNDC, Fountain Conference Room

2828 SW Corbett Ave

Portland, OR 97201

ATTENDANCE:

Rick Williams, Pam Neal, Navindra Gunawardena, Sarah Miller, Brice Barrett

I. CALL TO ORDER, REVIEW AND APPROVAL OF MINUTES– BRICE

- Brice called meeting to order
- Committee reviewed meeting minutes from September and October meetings
- Rick motioned to approve the minutes
- Meeting minutes were approved with no objection

II. ACTION ITEM REVIEW FROM OCTOBER MEETING

#	Action Item	Responsible Party	Current Status
1	Working with OWET to get companies in Connectory	Navindra	In Progress.
2	ECEDC Version Control and Change Management Response	Brice	In Progress
3	Connectory Road Show	Brice and Navindra	In progress
4	Generate Distribution of Profiles by NAICS codes	Navindra	In Progress
5	setup blog	Navindra	In progress
6	NW Connectory Traffic	Brice	In progress
7	Newsletter	Navindra	In progress
8	Establish sub-committee for technical oversight issues	Sarah and Rick	In progress
9	Connectory Email Blast	Brice	In Progress
10	Capturing different links, including www.northwestconnectory.com	Brice	In progress
11	Committee Policy on membership	Brice	In progress

- Removing #4, #5, #7, and #9 from list due to completion
- #3 Connectory Road show
 - I. Take Marian off action item
 - II. Rick – OBDD should request Connectory Exposure at Oregon Leadership summit
 - III. Need to generate small rural success stories using the Conenctory
 - IV. BDO Level small success stories
- Brice will buy northwestconnectory.com
- Navindra qill set a hard date for the newsletter

III. CONNECTORY OPERATIONS AND MAINTANENCE MOU DRAFT

- Majority of discussion occurred under Action item review
- Draft MOU was reviewed by committee
- ECEDC needs to provide basic system development life cycle process info. Possibly tie in with MOUT
- Targeting late January signing
- Budget is still being negotiated, will disclose to committee prior to signing MOU
- Does contract cycle need to be changed to align with calendar year or state budget cycle?
- Option of having a 16 month bridge to align with state funding cycle
- Focus on a customer relationship with ECEDC, move away from a Partner relationship

Action Item: Sarah sends out Language on Source code escrow by 12/31. Action item complete, text emailed on 12/7.

Action Item: Brice will forward testing plan provided by ECEDC to Rick and Sarah

Action Item: Source Code language inserted into O&M MOU by early January – Brice

IV. Connectivity Status Update – Navindra and Brice

- 3039 companies in OR and WA connectivity
 - I. 1399 OR Live, 430 offline
 - II. 1621 WA live, 211 offline
- Connectivity presentation made at last OSEIA meeting with help of Derrick Olsen
- December newsletter sent out, will have one in early January
- Seattle PNDC employee coming online in early Jan, part of responsibility will be profiling Seattle and other WA companies
- Announcement that Navindra will be leaving in June 2011.
 - I. Need to generate a plan to replace Navindra
 - II. Do we need someone at Navindra's level for a replacement
 - III. Create a system that produces similar results

Action item: Brice will contact Liz and Jeremy for Connectivity inclusion at Oregon leadership summit. Update – Done as of 12/8.

V. Business Oregon Update – Sarah

- No update till budget is resolved – approx. Feb 1 at earliest.

VI. PDC Update – Pam

- Small wind conf this week
- Clean tech cluster event at Solar world this week

VII. Action Item Review

VIII. Around the Table

IX. Meeting Adjourned

APPENDIX 4: Reference File A6 – Oct 2010 Connectory Newsletter

Having trouble viewing this email? [Click here](#)



The Northwest Connectory

A Buyer - Supplier Database

The Pacific Northwest is home to an impressive array of world-class companies with state-of-the-art product lines, technical expertise and manufacturing capabilities, ready and able to supply customers anywhere on the globe.

In order to help potential clients identify Northwest companies who can meet their needs - and continue to build value added supply chains - the Pacific Northwest Defense Coalition is partnering with the Defense Logistics Agency, Business Oregon, Portland Development Commission and Connectory.com to present the Northwest Connectory.

What is the Northwest Connectory?

- Online database containing detailed profiles of Pacific Northwest companies across all industries at every level of the supply chain.
- Tool to link Northwest businesses to opportunities around the country.
- This is a free service - there is no cost to either participants or users.
- There are already over 2000 Northwest Companies in the database, with more added everyday.

Lockheed Martin Connects with NW Manufacturer

Early Success Story

For Will Macia, President of Vancouver based textile manufacturer The Last US Bag Company, the Connectory has already demonstrated its power to connect companies.



This summer, officials from Lockheed Martin Space Systems needed to identify companies capable of sewing complex Orbital Transfer Bags for the International Space System. When the usual resources for identifying suppliers turned up nothing, Lockheed's team turned to the Northwest Connectory. A quick search for "Textile" turned up this small Washington business, which led to a visit from the Houston-based team to Macia's shop in Vancouver. While the contract hasn't yet been awarded, it's already viewed as a win for Macia.

"This is a clear cut example of why we designed the system," says Brice Barrett, Executive Director of the PNDC. "When the Defense Logistics Agency tasked us with bringing Northwest capabilities to the national defense industry base, we were hoping for just this kind of success."

October 2010 Issue

Come visit our booth at the following events:

OEDA Annual Conference
October 11th - 12th
Resort at the Mountain
Welches, OR

[Link to more info](#)

Governor's Aerospace Summit
October 20th - 21st
Lynnwood Convention Center
Lynnwood, WA

[Link to more info](#)

Sponsors:



Investing in Portland's Future



Have Success Stories?

Contact Us:

Navindra Gunawardena

Search, Find, Connect

Visit www.nwconnectory.com

Project Manager
2828 SW Corbett Ave
Suite 204
(888) 701 - 7632 ext 104
(503) 517 - 8095
navindra@pndc.us
www.nwconnectory.com

©2010 Northwest Connectory is a Project of the Pacific Northwest Defense Coalition

[Forward email](#)

 [SafeUnsubscribe!](#)



This email was sent to brice.barrett@pndc.us by navindra@pndc.us |
[Update Profile/Email Address](#) | Instant removal with [SafeUnsubscribe™](#) | [Privacy Policy](#).

Pacific Northwest Defense Coalition | 2828 SW Corbett Avenue | Suite 204 | Portland | OR | 97201

APPENDIX 4: Reference File A7 Dec 2010 Connectory Newsletter

Having trouble viewing this email? [Click here](#)



December 2010 Issue

NW Connectory reaches 3000 profiles

New Milestone achieved

The Northwest Connectory now has over 3000 profiles in its database! These profiles are nearly evenly distributed between the states of Oregon and Washington.

The profiles join the rest of those in the US Connectory, resulting in a searchable database of over 20,000 companies.

Showcased Profile of the Month: ONAMI

Beyond Manufacturing

The Northwest Connectory is not just for manufacturers to showcase their products. Any company that adds value in the process of getting a product to market is eligible for inclusion within the NW Connectory. This does include service providers such as consultants and testing laboratories.

With that in mind, our profile of the month belongs to the Oregon Nanoscience and Microtechnologies Institute (ONAMI). ONAMI is a public-private partnership and signature research center for the state of Oregon. It is an excellent venue for companies to seek out research and commercialization assistance.

[ONAMI's profile can be seen here](#)

ONAMI's profile captures the spectrum of equipment and capabilities hosted by the facilities of each institution that is a part of ONAMI.

Profile Creation Tip of the Month

Create a Concise Elevator Speech

Northwest Connectory profiles can and should be as detailed as possible. Certainly there is ample room to provide everything from basic corporate information to detailed equipment listing.

One area in which brevity is recommended is the Elevator Speech. This is the initial description of the company appearing immediately after the company name. Keep the section around 2-3 sentences, simply describing what services or products are provided.

What is the NW Connectory?

Upcoming events:

AWEA Small and Community Wind Conference

Dec. 7th - 9th

Oregon Convention Center
Portland, OR

[Link to more info](#)

Oregon Business Plan Leadership Summit

December 13th

Oregon Convention Center
Portland, OR

[Link to more info](#)

Sponsors:



Investing in Portland's Future



Have Success Stories?

Buyer-supplier Database

The Pacific Northwest is home to an impressive array of world-class companies with state-of-the-art product lines, technical expertise and manufacturing capabilities, ready and able to supply customers anywhere on the globe.

The Northwest Connectory is an online database containing detailed profiles of those companies. Profiles span across all industries at every level of the supply chain.

This is a free service - There is no cost to either participation or use

Contact Us:

Navindra Gunawardena
Project Manager
2828 SW Corbett Ave
Suite 204
(888) 701 - 7632 ext 104
(503) 517 - 8095
navindra@pndc.us
www.nwconnectory.com

Search, Find, Connect

Visit www.nwconnectory.com

©2010 Northwest Connectory is a Project of the Pacific Northwest Defense Coalition

[Forward email](#)



Try it FREE today.

This email was sent to brice.barrett@pndc.us by navindra@pndc.us | [Update Profile/Email Address](#) | Instant removal with [SafeUnsubscribe™](#) | [Privacy Policy](#).

Pacific Northwest Defense Coalition | 2828 SW Corbett Avenue | Suite 204 | Portland | OR | 97201

APPENDIX 4: Reference File A8 Feb 2011 Connectory Newsletter

Having trouble viewing this email? [Click here](#)



February 2011 Issue

Northwest Connectory Expands Seattle-area Clean Energy Business into Oregon

Applied Filter Technologies Brings Sales, Jobs Using Northwest Connectory

Portland, Ore. --Tim Robinson, chief operating officer of [Applied Filter Technologies](#) (AFT), a fast growing Clean Energy company in Bothell, WA, needed to find a local manufacturer for his business' fast-growing line of biogas filtration systems. AFT had been manufacturing its systems in Iowa, but was driven to consider options to streamline the logistics. Robinson was unsure of where to find the specialty skills to manufacture his company's complex system in the Pacific Northwest, so he turned to his trade association, the [Pacific Northwest Defense Coalition](#) (PNDC), and its buyer-supplier database called the Northwest Connectory for help.

Brice Barrett, the executive director of PNDC, took it from there. "We developed the Northwest Connectory with funding from the Defense Logistics Agency to help map the defense industry in our region," said Barrett, "but we've found that there are many uses for such a powerful database beyond just defense applications." So many uses, in fact, that the Oregon Business Development Department (OBDD) has invested in a pilot program to help get Oregon businesses into the Connectory. This investment paid off in a big way for [Vigor Industrial](#), a Portland, OR based manufacturer.

After generating a list of qualified vendors using the Northwest Connectory, AFT solicited proposals from several regional manufacturers. In the end, they chose Vigor Industrial to construct their systems.

Vigor is currently under contract to do an estimated \$750k worth of work and expects that there will be a recurring revenue stream from AFT projects that will be in the multiple millions of dollars on an annual basis. The project has created one new Project Management position and will retain or create 10 skilled labor positions over the next four months.

Vince Piscitello, business development manager at Vigor said, "This has been a great opportunity for our team to work with Applied Filter Technologies. We've been a part of the Northwest's manufacturing community for a long time, but there are new opportunities out there. We're glad that the folks at PNDC and the Northwest Connectory were there to put us in the path of opportunity by providing this useful new tool."

As for the Northwest Connectory, Barrett suspects this is just the first of many success stories to come: "This is a great demonstration of the technology we have developed to seek out manufacturing and technology development capabilities. We'll keep working to bring more money and jobs back to the Pacific Northwest."

Profile Tip of the Month

Upcoming events:

Alliance NW Conference

Mar. 10th

Americraft Showplex Exhibition & Convention Center
Puyallup, WA

[Link to more info](#)

Oregon Future Energy Conference

Apr. 12th - 13th

Oregon Convention Center
Portland, OR

[Link to more info](#)

Sponsors:



Investing in Portland's Future



Have Success Stories?

Certifications - Veteran Owned, Minority, ISO ...

Looking for a supplier for supplier with a specific designation? NW Connectory profiles enable companies any and all owner certifications their companies have, from ISO 9001 to being located in a HUBzone.

To find those suppliers, go to the NW Connectory Search page and either do a "word search" in the top half of the search panel or select the a preset certification from the drop downs located in the lower half.

Search, Find, Connect

Visit www.nwconnectory.com

Contact Us:

Navindra Gunawardena
Project Manager
2828 SW Corbett Ave
Suite 204
(888) 701 - 7632 ext 104
(503) 517 - 8095
navindra@pndc.us
www.nwconnectory.com

©2010 Northwest Connectory is a Project of the Pacific Northwest Defense Coalition

[Forward email](#)

 SafeUnsubscribe[®]

This email was sent to brice.barrett@pndc.us by navindra@pndc.us |
[Update Profile/Email Address](#) | Instant removal with [SafeUnsubscribe™](#) | [Privacy Policy](#).

Pacific Northwest Defense Coalition | 2828 SW Corbett Avenue | Suite 204 | Portland | OR | 97201



APPENDIX 4: Reference File A9 - Applied Filter Story

Northwest Connector Expands Seattle Area Clean Energy Business Into Oregon Applied Filter Technology Brings Sales, Jobs to Portland

The Northwest Connector—a government-funded database developed to help manufacturing business in the region—has created another match, bringing \$750,000 in clean-energy manufacturing dollars and 10 new jobs to Portland-based Vigor Industrial.

Tim Robinson, Chief Operating Officer of Applied Filter Technology (AFT), a clean energy company in Bristol, Wis., needed to find a local manufacturer for his fast-growing business's biogas filtration systems. AFT was manufacturing its systems in Iowa, but knew it could save both money and time by identifying a local supplier to partner with.

Robinson was unsure of whom in the Pacific Northwest to find the specialty skills to manufacture his company's complex systems, so he turned to his trade association, the Pacific Northwest Defense Coalition (PNDC), and its buyer-supplier database, the Northwest Connector, for help.

Eric Barrett, the Executive Director of PNDC, says "We developed the Northwest Connector with funding from the Defense Logistics Agency to help map the defense industry in our region," said Barrett. "But we've found that there are many uses for such a powerful database beyond just defense applications."

So many uses, in fact, that the Oregon Business Development Department (OBDD) and the Portland Development Commission (PDC) have invested in a pilot program to help get businesses into the Connector. These investments by the city and the state have paid off in a big way for Vigor Industrial, a Portland-based manufacturer.

After generating a list of qualified vendors using the Northwest Connector, AFT solicited proposals from several regional manufacturers. In the end, the company chose Vigor Industrial to construct its systems.

Vigor expects its current AFT contract for an estimated \$750,000 of work to grow into a recurring revenue stream of millions of dollars annually. The project has created one new project management position and will retain or create 10 skilled labor positions over the next four months.

"This has been a great opportunity for our team to work with Applied Filter Technology," said Vince Pacheco, Business Development Manager at Vigor. "We've been a part of the Northwest's manufacturing community for a long time, but there are new opportunities out there. We're glad that the folks at PNDC and the Northwest Connector put us in the path of opportunity by providing this useful new tool."

As for the Northwest Connector, Barrett expects that just the first of many success stories to come: "This business relationship is a great demonstration of the technology we have developed to seek out manufacturing and technology development capabilities. We'll keep working to bring more money and jobs back to the Pacific Northwest."

www.nwconnector.com.

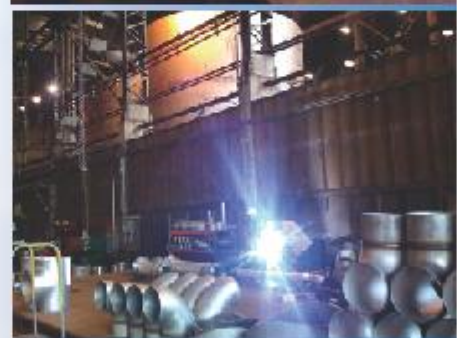

APPENDIX 4: Reference File A10 – LUSB Story

The Northwest Connector Buyer - Supplier Database

The Pacific Northwest is home to an array of world-class manufacturers with state-of-the-art product lines, technical expertise and capabilities. They are ready and able to supply customers anywhere on the globe.

In order to help potential clients identify Northwest companies who can meet their needs – and continue to build value added supply chains – the Pacific Northwest Defense Coalition has engaged Connector.com along with several public and private groups to present the Northwest Connector.



What is the Northwest Connector?

The Northwest Connector is an online database containing detailed profiles of Pacific Northwest companies across all industries at every level of the supply chain.

- The purpose of the tool is to link Northwest businesses to opportunities around the country via a robust, searchable, online "buyer/supplier" database.
- The database contains detailed company profiles and includes fields that describe specific capabilities, products and services. Our staff verifies each profile's information.
- This is a free service – there is no cost to either participants or users.
- The Northwest Connector is created in partnership with Connector.com, a proven development tool that has been successfully deployed in Southern California to promote companies and foster business-to-business interaction.
- There are already over 2000 Northwest Companies in the database, with more added everyday.

Lockheed Martin Connects with NW Manufacturer (An Early Success Story)



For Will Mach, President of Vancouver based textile manufacturer The Last US Bag Company, the Connector has already demonstrated its power to connect.

This summer, officials from Lockheed Martin Space Systems needed to identify companies capable of sewing complex Orbital Transfer Bags for the International Space System. Lockheed's team turned to the Northwest Connector. A quick search for "Textile" turned up this small Washington business, which led to a visit from the Houston-based team to Mach's shop in Vancouver. While the contract hasn't yet been awarded, it's already viewed as a win for Mach.

"This is a clear cut example of why we designed the system," says Eric Barrett, Executive Director of the PNDC. "When the Defense Logistics Agency asked us with bringing Northwest capabilities to the national defense industry home, we were hoping for just this kind of success."

Serving in Portland's Honor

PDC

Portland Defense Coalition



business
oregon

8888 SW CORBETT AVENUE
SUITE 204
PORTLAND, OR 97201

(888) 701-PNDC 17633
MOBILE (503) 929-1939
FAX (503) 517-8058

APPENDIX 4: Reference File A11 – Connectory Corp Idea 022310

Scheme for the representation of entities within an Corporation

Proposal:

Use the unique Connectory ID # assigned to each profile to represent relationships between entities within a corporation.

1

Specifics:

- Each self-sufficient entity has a full Connectory profile, ID # and represented by a map balloon.
- List each Business Unit as a branch of Parent company. Listing in Parent Company's profile includes link using the ID #.
- List other business units as branches in specific business unit's profile. Included link via profile ID.
- For branches that do not have own profile, list as branches including city/state/country.
 - Mirror profile for each branch in location given by city/state/country.

2

Example: See Figure #1.

- Parent Corporation has ID # 1.
 - Business Unit # 1 (ID #2) is listed in "Branches" section
 - Business Unit #2 (ID #3) is listed in "Branches" section
 - No Headquarters entry in profile
- Business Unit #1 has ID #2
 - Business Unit #2 (ID #3) is listed in "Branches" section
 - Parent Corporation (ID #1) is listed in "HQ Address" section
- Business Unit #2 has ID #3
 - Parent Corporation (ID #1) is listed in "HQ Address" section
 - Business Unit #2 (ID #2) is listed in "Branches" section
 - 4 other branches without individual profiles mirror the profile of Business Unit #1.

3

Figure 1: Relationship Diagram

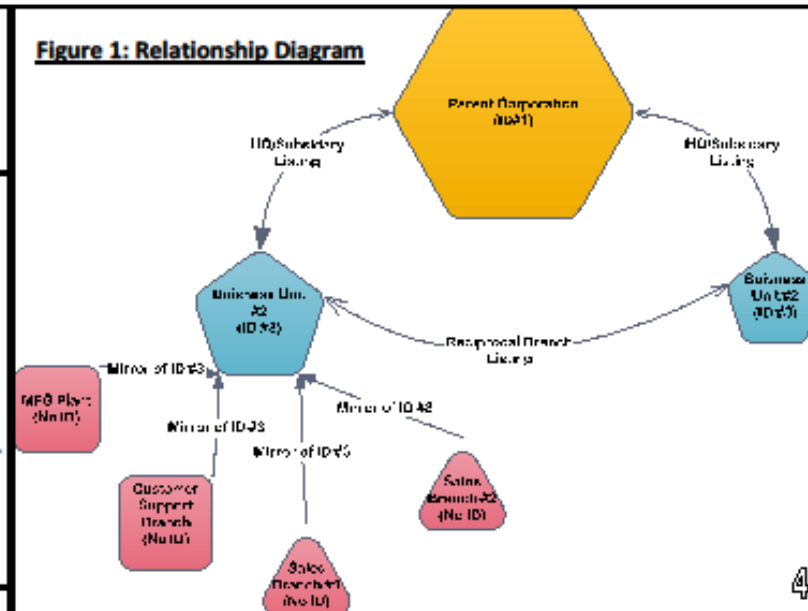

4

Benefits:

- Structure allows for different granularity levels while representing large company.
- Allows better geographical representation of corporate presence. Searches prioritized by geography will be more accurate.
- Utilizes current Connectory structure. Method is provided to connect profiles but is not required. Current profiles can be modified.

5

APPENDIX 4: Reference File A12 – Oregon Key Industries and the NW Connectory

Classifying Connectory profiles along Oregon Industry definitions

A method of determining the distribution of Connectory profiles along the Oregon Key Industry definitions

Prepared by Navindra Gunawardena
August 31, 2010

Introduction:

A method was developed to determine the distribution of Oregon companies in the Connectory within the definition of Business Oregon's 5 Key Industries: Outdoor Gear and Active Wear, Advanced Manufacturing, High Technology, Wood and Forest Products, and Clean Technology. The method initially determined the distribution of NAICS codes but subsequently gravitated to the distribution of Companies in order to impose meaningful constraints on the results.

Methods:

Python Programming language was used to write a script that assigned Oregon companies to the Oregon's 5 key industries and associated sub-industries. The assignment of each company to key industry category was made through a reference chart of NAICS codes to Oregon Key Industry classifications. The reference chart was provided by Economist Michael Anderson at Business Oregon, see Appendix #2. The Initial data set of 996 companies was provided by East County EDC and included the name of the company, NAICS Code(s), and County.

The script compared each company's provided NAICS codes against the reference table. For each NAICS code, if the check resulted in a new Key Industry or Sub-Industry category, then +1 was added to the count for the given Business Development officer (BDO) region designation and given County designation. This method resulted in companies being counted for each Key Industry only once, however allowed for a company to be counted in more than one Sub-Industry. The method also allowed for representation in more than one Key Industry. The BDO assignment was done via a reference table created using information from Business Oregon's web site. See Appendix #3 for County to BDO reference table.

The Python code used can be provided upon request along with the original data set.

Results:

Table # 1 contains the count of companies per BDO region for each Key and Sub-Industry.
Table #2 contains the count of companies per county for each Key and Sub-Industry.

Both Table #1 and Table #2 are included in Appendix #1 at the end of this report.

Conclusions:

The method developed for this paper's work can be applied to any sort of cluster or industry analysis for any size of data set, given a data set with sufficient information, proper specification of the desired industry or cluster breakdown and the desired regional segmentation.

Appendix #1 – Result Tables:

Table 1: Key and Sub-Industries vs BDO	Clafflin	Fox	Freeman	Holzgang	Houle	Jackson	Meece	Minster	Warren	Total
Outdoor Gear and Active Wear	0	2	18	1	2	2	47	2	4	78
Activewear	0	2	11	1	1	2	44	0	4	65
Outdoor Gear	0	0	7	0	1	0	3	2	0	13
Advanced Manufacturing	13	42	110	12	13	15	129	10	33	377
Processed Food and Beverage Products	3	12	13	4	6	3	22	7	10	80
Metals	8	24	90	4	3	8	72	2	18	229
Transportation Equipment and Parts	2	9	20	5	4	6	49	1	6	102
High Technology	3	13	121	13	5	14	128	1	32	330
Business Services	3	8	72	5	5	8	98	1	21	221
Communication Equipment	0	1	16	1	0	0	9	0	1	28
Electronic and Advanced Materials	0	5	50	7	0	6	28	0	7	103
Information Technology	1	0	15	0	1	1	16	0	2	36
Medical Products	0	2	11	5	0	1	7	0	4	30
Wood and Forest Products	9	10	31	11	5	9	23	3	15	116
Forestry	9	8	28	11	5	8	21	3	12	105
Value-added Wood Products	4	3	5	2	2	5	5	0	5	31
Clean Technology	12	25	111	21	6	19	88	3	32	317
Green Building and Value-Added Wood Products	7	11	49	11	3	12	40	1	20	154
Water and Waste Water Management	1	0	11	2	1	2	14	0	3	34
REPM-Utilities and Power Construction	1	0	3	0	1	1	8	2	1	17
REPM-Energy Related Manufacturing	4	11	55	8	2	7	32	1	10	130
REPM-Professional and Technical Services	2	5	30	1	2	3	27	0	8	78
Wind Manufacturing	2	5	38	7	2	4	25	1	7	91
Solar Manufacturing	1	10	34	4	1	4	13	0	8	75

Table 2: Key and Sub-Industries vs County	Baker	Benton	Clackamas	Clatsop	Columbia	Coos	Crook	Curry	Deschutes	Douglas	Gilliam	Grant	Harney	Hood River	Jackson	Jefferson	Josephine	Klamath	Lake	Lane	Lincoln	Linn	Malheur	Marion	Morrow	Multnomah	Polk	Sherman	Tillamook	Umatilla	Union	Wallowa	Wasco	Washington	Wheeler	Yamhill	Totals	
Outdoor Gear and Active Wear	1	0	8	0	2	0	0	2	0	0	1	0	1	1	0	0	0	0	0	4	0	0	0	1	0	46	0	0	0	0	0	0	0	10	0	1	78	
Activewear	0	0	5	0	1	0	0	2	0	0	0	0	1	1	0	0	0	0	0	4	0	0	0	1	0	43	0	0	0	0	0	0	0	6	0	1	65	
Outdoor Gear	1	0	3	0	1	0	0	0	0	0	1	0	0	0	0	0	0	0	0	0	0	0	0	0	3	0	0	0	0	0	0	0	4	0	0	13		
Advanced Manufacturing	2	2	52	3	5	4	0	2	14	7	0	0	0	3	7	1	3	2	0	23	1	8	3	23	1	125	5	0	4	3	1	0	1	58	0	14	377	
Processed Food and Beverage Products	0	0	6	3	0	2	0	2	1	0	0	0	2	3	1	0	1	0	7	1	3	3	8	1	20	1	0	2	3	0	0	0	7	0	3	80		
Metals	2	2	41	0	2	1	0	2	8	5	0	0	0	1	1	0	2	1	0	11	0	5	0	13	0	70	2	0	1	0	0	0	1	49	0	9	229	
Transportation Equipment and Parts	0	0	15	0	3	1	0	0	6	1	0	0	0	0	3	0	2	0	0	6	0	0	0	4	0	49	2	0	1	0	1	0	0	5	0	3	102	
High Technology	0	11	38	0	3	1	0	0	14	2	0	0	0	4	9	0	2	1	1	17	1	4	0	8	0	122	1	0	1	0	0	1	2	83	0	4	330	
Business Services	0	9	24	0	3	1	0	0	8	2	0	0	0	1	3	0	0	1	1	11	1	1	0	5	0	95	1	0	1	0	0	1	2	48	0	2	221	
Communication Equipment	0	0	5	0	0	0	0	0	0	0	0	0	1	0	0	1	0	0	0	1	0	0	0	1	0	8	0	0	0	0	0	0	0	11	0	0	28	
Electronic and Advanced Materials	0	2	11	0	0	0	0	0	6	0	0	0	4	5	0	2	0	0	0	2	0	3	0	3	0	24	0	0	0	0	0	0	0	0	39	0	2	103
Information Technology	0	0	4	0	0	1	0	0	1	0	0	0	0	0	0	0	0	0	2	1	0	0	0	0	15	0	0	0	0	0	0	1	11	0	0	36		
Medical Products	0	1	3	0	0	0	0	1	0	0	0	0	0	0	3	0	1	0	1	3	0	0	0	1	0	7	0	0	0	0	0	0	0	8	0	1	30	
Wood and Forest Products	0	2	10	0	3	3	3	1	4	5	0	2	0	0	7	2	2	1	1	10	1	3	0	8	0	23	0	0	1	1	0	0	0	21	0	2	116	
Forestry	0	1	9	0	3	3	3	1	3	5	0	2	0	0	7	2	2	1	1	8	1	3	0	6	0	21	0	0	1	1	0	0	0	19	0	2	105	
Value-added Wood Products	0	1	2	0	1	2	2	1	2	1	0	0	0	0	0	1	1	0	4	0	0	0	3	0	5	0	0	1	0	0	0	0	0	3	0	0	31	
Clean Technology	2	6	38	0	4	2	3	1	15	9	0	1	0	3	13	1	5	2	1	19	0	7	0	17	0	84	2	0	2	0	0	0	1	73	0	6	317	
Green Building and Value-Added Wood Products	0	5	15	0	2	1	3	1	8	5	0	1	0	1	7	1	2	1	1	13	0	2	0	8	0	39	0	0	1	0	0	0	0	34	0	3	154	
Water and Waste Water Management	0	0	6	0	1	0	0	0	2	1	0	0	0	0	0	0	2	0	0	1	0	2	0	0	14	0	0	0	0	0	0	0	5	0	0	34		
REPM-Utilities and Power Construction	2	1	1	0	0	0	0	1	1	0	0	0	0	0	0	0	0	0	0	0	0	0	0	0	7	0	0	1	0	0	0	1	2	0	0	17		
REPM-Energy Related Manufacturing	1	2	20	0	2	1	0	0	7	3	0	0	0	2	5	0	3	0	0	3	0	5	0	6	0	30	1	0	0	0	0	0	0	35	0	4	130	
REPM-Professional and Technical Services	0	2	11	0	1	0	0	0	3	2	0	0	0	1	1	0	0	0	0	5	0	1	0	3	0	26	0	0	1	0	0	0	0	19	0	2	78	
Wind Manufacturing	1	1	13	0	2	0	0	0	4	2	0	0	0	1	4	0	3	0	0	3	0	3	0	5	0	24	0	0	0	0	0	0	0	25	0	0	91	
Solar Manufacturing	0	2	9	0	1	0	0	0	4	1	0	0	0	0	2	0	1	1	0	3	0	3	0	7	0	13	1	0	0	0	0	0	0	25	0	2	75	

Appendix #2 – Oregon Key Industry Definition table:

NAICS	Key-Industry	Sub-Industry
313	Outdoor Gear and Active Wear	Activewear
314	Outdoor Gear and Active Wear	Activewear
315	Outdoor Gear and Active Wear	Activewear
316	Outdoor Gear and Active Wear	Activewear
4243	Outdoor Gear and Active Wear	Activewear
333292	Outdoor Gear and Active Wear	Activewear
551	Outdoor Gear and Active Wear	Activewear
332211	Outdoor Gear and Active Wear	Outdoor Gear
33992	Outdoor Gear and Active Wear	Outdoor Gear
311	Advanced Manufacturing	Processed Food and Beverage Products
1141	Advanced Manufacturing	Processed Food and Beverage Products
3121	Advanced Manufacturing	Processed Food and Beverage Products
4248	Advanced Manufacturing	Processed Food and Beverage Products
42441	Advanced Manufacturing	Processed Food and Beverage Products
42442	Advanced Manufacturing	Processed Food and Beverage Products
42443	Advanced Manufacturing	Processed Food and Beverage Products
42444	Advanced Manufacturing	Processed Food and Beverage Products
42445	Advanced Manufacturing	Processed Food and Beverage Products
42446	Advanced Manufacturing	Processed Food and Beverage Products
42447	Advanced Manufacturing	Processed Food and Beverage Products
42448	Advanced Manufacturing	Processed Food and Beverage Products
42449	Advanced Manufacturing	Processed Food and Beverage Products
333294	Advanced Manufacturing	Processed Food and Beverage Products
331	Advanced Manufacturing	Metals
332	Advanced Manufacturing	Metals
2122	Advanced Manufacturing	Metals
3333	Advanced Manufacturing	Metals
3334	Advanced Manufacturing	Metals
3335	Advanced Manufacturing	Metals
3336	Advanced Manufacturing	Metals
3339	Advanced Manufacturing	Metals
33322	Advanced Manufacturing	Metals
42351	Advanced Manufacturing	Metals
213114	Advanced Manufacturing	Metals
333293	Advanced Manufacturing	Metals
333298	Advanced Manufacturing	Metals
3361	Advanced Manufacturing	Transportation Equipment and Parts
3362	Advanced Manufacturing	Transportation Equipment and Parts
3363	Advanced Manufacturing	Transportation Equipment and Parts
3364	Advanced Manufacturing	Transportation Equipment and Parts
3365	Advanced Manufacturing	Transportation Equipment and Parts
3366	Advanced Manufacturing	Transportation Equipment and Parts
3369	Advanced Manufacturing	Transportation Equipment and Parts
4231	Advanced Manufacturing	Transportation Equipment and Parts
541	High Technology	Business Services

NAICS	Key-Industry	Sub-Industry
5614	High Technology	Business Services
3341	High Technology	Communication Equipment
3342	High Technology	Communication Equipment
3343	High Technology	Communication Equipment
3346	High Technology	Communication Equipment
42343	High Technology	Communication Equipment
335	High Technology	Electronic and Advanced Materials
425	High Technology	Electronic and Advanced Materials
3344	High Technology	Electronic and Advanced Materials
4236	High Technology	Electronic and Advanced Materials
333295	High Technology	Electronic and Advanced Materials
334511	High Technology	Electronic and Advanced Materials
334512	High Technology	Electronic and Advanced Materials
334513	High Technology	Electronic and Advanced Materials
334514	High Technology	Electronic and Advanced Materials
334515	High Technology	Electronic and Advanced Materials
334516	High Technology	Electronic and Advanced Materials
334517	High Technology	Electronic and Advanced Materials
334518	High Technology	Electronic and Advanced Materials
334519	High Technology	Electronic and Advanced Materials
516	High Technology	Information Technology
517	High Technology	Information Technology
518	High Technology	Information Technology
519	High Technology	Information Technology
5112	High Technology	Information Technology
3254	High Technology	Medical Products
3391	High Technology	Medical Products
334510	High Technology	Medical Products
113	Wood and Forest Products	Forestry
321	Wood and Forest Products	Forestry
322	Wood and Forest Products	Forestry
1153	Wood and Forest Products	Forestry
4241	Wood and Forest Products	Forestry
42331	Wood and Forest Products	Forestry
33321	Wood and Forest Products	Value-added Wood Products
33711	Wood and Forest Products	Value-added Wood Products
333291	Wood and Forest Products	Value-added Wood Products
337211	Wood and Forest Products	Value-added Wood Products
337212	Wood and Forest Products	Value-added Wood Products
423990	Wood and Forest Products	Value-added Wood Products
325520	Clean Technology	Green Building and Value-Added Wood Products
32199	Clean Technology	Green Building and Value-Added Wood Products
5413	Clean Technology	Green Building and Value-Added Wood Products
32191	Clean Technology	Green Building and Value-Added Wood Products
325510	Clean Technology	Green Building and Value-Added Wood Products

NAICS	Key-Industry	Sub-Industry
562910	Clean Technology	Green Building and Value-Added Wood Products
32121	Clean Technology	Green Building and Value-Added Wood Products
337110	Clean Technology	Green Building and Value-Added Wood Products
33361	Clean Technology	Water and Waste Water Management
541620	Clean Technology	Water and Waste Water Management
334513	Clean Technology	Water and Waste Water Management
33391	Clean Technology	Water and Waste Water Management
334514	Clean Technology	Water and Waste Water Management
22111	Clean Technology	REPM-Utilities and Power Construction
22112	Clean Technology	REPM-Utilities and Power Construction
2213	Clean Technology	REPM-Utilities and Power Construction
237130	Clean Technology	REPM-Utilities and Power Construction
326199	Clean Technology	REPM-Energy Related Manufacturing
332312	Clean Technology	REPM-Energy Related Manufacturing
332721	Clean Technology	REPM-Energy Related Manufacturing
333298	Clean Technology	REPM-Energy Related Manufacturing
33361	Clean Technology	REPM-Energy Related Manufacturing
334418	Clean Technology	REPM-Energy Related Manufacturing
334515	Clean Technology	REPM-Energy Related Manufacturing
334519	Clean Technology	REPM-Energy Related Manufacturing
33531	Clean Technology	REPM-Energy Related Manufacturing
3359	Clean Technology	REPM-Energy Related Manufacturing
54133	Clean Technology	REPM-Professional and Technical Services
541620	Clean Technology	REPM-Professional and Technical Services
326199	Clean Technology	Wind Manufacturing
331511	Clean Technology	Wind Manufacturing
332312	Clean Technology	Wind Manufacturing
332991	Clean Technology	Wind Manufacturing
333412	Clean Technology	Wind Manufacturing
333611	Clean Technology	Wind Manufacturing
333612	Clean Technology	Wind Manufacturing
333613	Clean Technology	Wind Manufacturing
334418	Clean Technology	Wind Manufacturing
334519	Clean Technology	Wind Manufacturing
335312	Clean Technology	Wind Manufacturing
335999	Clean Technology	Wind Manufacturing
325211	Clean Technology	Solar Manufacturing
326113	Clean Technology	Solar Manufacturing
327211	Clean Technology	Solar Manufacturing
331422	Clean Technology	Solar Manufacturing
332322	Clean Technology	Solar Manufacturing
334413	Clean Technology	Solar Manufacturing
334515	Clean Technology	Solar Manufacturing
335313	Clean Technology	Solar Manufacturing
335911	Clean Technology	Solar Manufacturing
335931	Clean Technology	Solar Manufacturing
335999	Clean Technology	Solar Manufacturing

Appendix #3 – Business Development Officer County Assignment:

BDO	County
Clafin	Coos
Clafin	Curry
Clafin	Douglas
Fox	Marion
Fox	Polk
Fox	Yamhill
Freeman	Clackamas
Freeman	Washington
Holzgang	Harney
Holzgang	Jackson
Holzgang	Josephine
Holzgang	Klamath
Holzgang	Lake
Houle	Clatsop
Houle	Columbia
Houle	Lincoln
Houle	Tillamook
Jackson	Crook
Jackson	Deschutes
Jackson	Gilliam
Jackson	Jefferson
Jackson	Sherman
Jackson	Wheeler
Meece	Hood River
Meece	Multnomah
Meece	Wasco
Minster	Baker
Minster	Grant
Minster	Malheur
Minster	Morrow
Minster	Umatilla
Minster	Union
Minster	Wallowa
Warren	Benton
Warren	Lane
Warren	Linn

APPENDIX 4: Reference File A13 – Connectory Search Report 051910

Report: Connectivity Searches using multiple zip and NAICS codes

Date: 5/19/2010

Author: Navindra Gunawardena

Overview:

The field search capabilities of the Connectivity are explored in this report, with emphasis on the behavior of multiple zip or NAICS codes included as search criteria. Three changes are proposed that could improve the quality of the user experience along with enabling a greater range of searches.

Key:

\wedge - AND

\vee - OR

\cap - Intersection of Set

\cup - Union of Set

R = Search Result set

S = Search parameters

{A} = Set A of companies

{NWC} = All companies in NW Connectivity

{OR} = All Oregon Companies

n(A) = number of companies in Set A.

\emptyset = null set; no companies

Current Behavior:

The current search capabilities are in two parts, a keyword search and a field search.

The Keyword search has four fields: "all of the words", "exact phrase", "any of the words" and "without the words". A black box Google search engine is used to execute and rank result set.

The Field Search has the following field lines: "state/county", "area code", "Zip Code(s)", "NAICS Code(s)", "Industry Sector", "Quality Certifications", "Owner Certifications", "License Certifications".

There is a toggle at the top of the Field search area that can choose between AND Field search or OR field search. This toggle results in each field line contributing to the search in the selected fashion.

Ex.

1. AND Field Search, OR for State, NAICS code = NAICS#1, and ISO 9001

$$S = \wedge \text{OR} + \wedge \text{NAICS\#1} + \wedge \text{"ISO 9001"} \Rightarrow R = \{\text{OR}\} \cap \{\text{NAICS\#1}\} \cap \{\text{"ISO 9001"}\}$$

If NAICS#1 = 332710 – "Machine Shops"

then n(R) = 6. Those are companies that are in Oregon, are ISO 9001 and identify with NAICS code 332701.

2. OR Field Search, OR for State, NAICS code = NAICS#1, and ISO 9001

$$S = \vee \text{OR} + \vee \text{NAICS\#1} + \vee \text{"ISO 9001"} \Rightarrow R = \{\text{OR}\} \cup \{\text{NAICS\#1}\} \cup \{\text{"ISO 9001"}\} \text{ and } n(R) = 900$$

These are companies in NW network that are in Oregon or ISO 9001 or identify with NAICS code 332710

The Field Search Rankings according to Jo Marie's email to me are the following:

- **Age of profile** (how long profile has been in Connectory) – this is similar to age of domain and age of site which search engines use as criteria
- **Recency of profile update** – this supports EDC policy to have profiles updated each year. When “confirming” their content is correct each year, the system looks at this as an “update”. Profiles that are ignored for large periods of time would be ranked lower.

The results of the field and keyword search are always in AND mode.

$$R = \{\text{Keyword Search Results}\} \cap \{\text{Field Search Results}\}$$

While the ranking of both the Field and Keyword searches has been defined, what is the established ranking when both areas are used? Does the Field just reduce the Keyword set and the original keyword rankings used?

I observed the following: When I selected “OR Field Search” and leaving everything else untouched resulted in $n(R) = 0$, though when I selected “AND Field Search” and leaving everything else untouched the search returned $n(R) = 999+$? I would think that either search should result in $n(R) = n(\{\text{NWC}\})$. I observed the same behavior when similar searches were run on the US Connectory.

The Field search allows for multiple Zip Codes and Multiple NAICS codes. This results in the following behaviors for the two zip code cases:

3. AND Field Search, Zip Code(s) = “97006,97201”

$$S = \wedge "97006" + \wedge "97201" \Rightarrow R = \{ "97006" \} \cap \{ "97201" \} = \emptyset \text{ and } n(R) = 0$$

4. OR Field Search, Zip Code(s) = “97006,97201”

$$S = \vee "97006" + \vee "97201" \Rightarrow R = \{ "97006" \} \cup \{ "97201" \} \text{ and } n(R) = 21$$

This is true for multiple (p) zip codes also:

5. AND Field Search, Zip Code(s) = “ZIP#1, ZIP#2,...,ZIP#p”

$$S = \wedge "ZIP\#1" + \wedge "ZIP\#2" + \dots + \wedge "ZIP\#p" \Rightarrow R = \{ "ZIP\#1" \} \cap \{ "ZIP\#2" \} \cap \dots \cap \{ "ZIP\#p" \} = \emptyset$$

and $n(R) = 0$

6. OR Field Search, Zip Code(s) = “ZIP#1, ZIP#2,...,ZIP#p”

$$S = \vee "ZIP\#1" + \vee "ZIP\#2" + \dots + \vee "ZIP\#p" \Rightarrow R = \{ "ZIP\#1" \} \cup \{ "ZIP\#2" \} \cup \dots \cup \{ "ZIP\#p" \}$$

and $n(R) = n(\text{ZIP\#1}) + n(\text{ZIP\#2}) + \dots + n(\text{ZIP\#p})$

There is only one searchable zip code for each company. I tested this assumption out by searching for an Oregon company, Soda Express Inc (connectoryID# 23070). That company has a local address zip code of 97062 and a mailing address zip code of 97070.

Field searching by zip code 97062 returned results than included Soda Express, while 97070 did not return Soda Express.

There is no space for entering zip codes for Corporate Headquarters or any of the Branches. So it appears that the only field searchable zip code is the one for the local address.

For multiple (q) NAICS Codes:

7. AND Field Search, NAICS Code(s) = "NAICS#1, NAICS #2,..., NAICS #q"

$S = \wedge \text{"NAICS \#1"} + \wedge \text{"NAICS \#2"} + \dots + \wedge \text{"NAICS \#p"} \Rightarrow R = \{\text{"NAICS \#1"}\} \cap \{\text{"NAICS \#2"}\} \cap \dots \cap \{\text{"NAICS \#q"}\}$

and $n(R)$ is not always 0. However my intuition tells me that this is number is small for $p = 2$ with the exception of carefully selected combinations and very small for $p > 2$.

8. OR Field Search, NAICS Code(s) = "NAICS #1, NAICS #2,..., NAICS #q"

$S = \vee \text{"NAICS \#1"} + \vee \text{"NAICS \#2"} + \dots + \vee \text{"NAICS \#p"} \Rightarrow R = \{\text{"NAICS \#1"}\} \cup \{\text{"NAICS \#2"}\} \cup \dots \cup \{\text{"NAICS \#q"}\}$

and $n(R) = n(\text{NAICS \#1}) + n(\text{NAICS \#2}) + \dots + n(\text{NAICS \#q})$

This search results in all the companies that identify with all p NAICS codes.

Using the example given right by the NAICS Code search box, "423330,339920,336991", results in $n(R) = 0$ for the AND Field search, and $n(R) = 17$ for the OR Field search. This is the result in the NW Network.

For the US Connector, the results are $n(R) = 0$ for the AND Field search, and $n(R) = 136$ for the OR Field search.

Proposed Change #1:

Assume that all companies have one zip code and one NAICS code. While companies can have more than one NAICS code, searching for companies that have multiple NAICS codes is probably too restrictive of a search.

I propose that when multiple zip codes or NAICS codes are entered into the appropriate Field Search line, the search parameters are always OR with respect to each other. The AND/OR toggle determines if the specific line is taken as AND/OR with respect to the entire search.

Ex: Multiple NAICS and Zip Codes.

NAICS Code(s) = "NAICS#1, NAICS #2... NAICS #q"

Zip Code(s) = "ZIP#1, ZIP#2 ... ZIP#p"

9. AND Field Search Toggle active

$S = \wedge(\vee \text{"ZIP\#1"} + \vee \text{"ZIP\#2"} + \dots + \vee \text{"ZIP\#p"}) + \wedge(\vee \text{"NAICS \#1"} + \vee \text{"NAICS \#2"} + \dots + \vee \text{"NAICS \#p"})$

$R = \{ \{ \text{"ZIP\#1"} \} \cup \{ \text{"ZIP\#2"} \} \cup \dots \cup \{ \text{"ZIP\#p"} \} \} \cap \{ \{ \text{"NAICS \#1"} \} \cup \{ \text{"NAICS \#2"} \} \cup \dots \cup \{ \text{"NAICS \#q"} \} \}$

This results in all companies that both are in one of the specified zip codes and have one of the specified NAICS codes.

10. OR Field Search Toggle active

$S = \vee(\vee \text{"ZIP\#1"} + \vee \text{"ZIP\#2"} + \dots + \vee \text{"ZIP\#p"}) + \vee(\vee \text{"NAICS \#1"} + \vee \text{"NAICS \#2"} + \dots + \vee \text{"NAICS \#p"})$

$R = \{ \{ \text{"ZIP\#1"} \} \cup \{ \text{"ZIP\#2"} \} \cup \dots \cup \{ \text{"ZIP\#p"} \} \} \cup \{ \{ \text{"NAICS \#1"} \} \cup \{ \text{"NAICS \#2"} \} \cup \dots \cup \{ \text{"NAICS \#q"} \} \}$

This results in all companies that are either in the specified zip codes or have one of the specified NACIS codes.

Proposed Change #2:

On top of Change #1, add an AND/OR toggle to each line in the field search. See photoshopped image below. This can result in enabling searches such as:

- All Oregon companies that are either ISO 9001 or WOB
- All companies that are Oregon or SW Washington zip codes that have a particular NACIS Code
- All companies that are in aerospace and have AS 9000, who are in either WA or have a Portland metro zip code.

<input checked="" type="radio"/> AND <input type="radio"/> OR	State: <input type="text" value="Select a State"/>	County: <input type="text" value="- Select a County -"/>
<input checked="" type="radio"/> AND <input type="radio"/> OR	Area Code: <input type="text"/>	
<input checked="" type="radio"/> AND <input type="radio"/> OR	Zip Code(s): <input type="text" value="97070"/> <small>(example: 92009,92001,92109)</small>	
<input checked="" type="radio"/> AND <input type="radio"/> OR	NAICS Code(s): <input type="text"/> <small>(example: 423330,339920,336991)</small>	
<input checked="" type="radio"/> AND <input type="radio"/> OR	Industry Sector: <input type="text" value="Select Industry Sector"/>	
<input checked="" type="radio"/> AND <input type="radio"/> OR	Quality Certifications: <input type="text" value="Select Quality Certifications"/>	
<input checked="" type="radio"/> AND <input type="radio"/> OR	Owner Certifications: <input type="text" value="Select Owner Certifications"/>	
<input checked="" type="radio"/> AND <input type="radio"/> OR	License Certifications: <input type="text" value="Select License Certifications"/>	
<input type="button" value="Search"/>		

Figure 1: Photoshopped screenshot showing proposed change #2

Proposed Change #3:

Take the behaviors of the search box found in the mapping area and apply that same behavior to the field search. One can chose to add lines of criteria that have add/or options and drop downs listing criteria and associated options.

This change can enable searches such as the following:

- Search in multiple states and/or counties
- All Oregon and Washington Companies that are Aerospace and either women or veteran owned.
- Portland Metro/SW Washington companies that manufacture plastics
- Companies that have capability to manufacture large tanks who are located near shipping ports (Seattle, Portland, San Diego, LA, SF etc).



The screenshot shows a search interface titled "Search Map". It features a search bar with a dropdown menu for "Name" and a "contains" dropdown. Below this, there is a section labeled "with distance" containing two rows of distance filters: "and less than [input] miles from" and "US Address or Zip Code: [input] and less than [input] miles from". A "Select location" button is present. At the bottom, it shows "Maximum search results: 200" and a "Search" button.

Figure 2: search box with one line of criteria

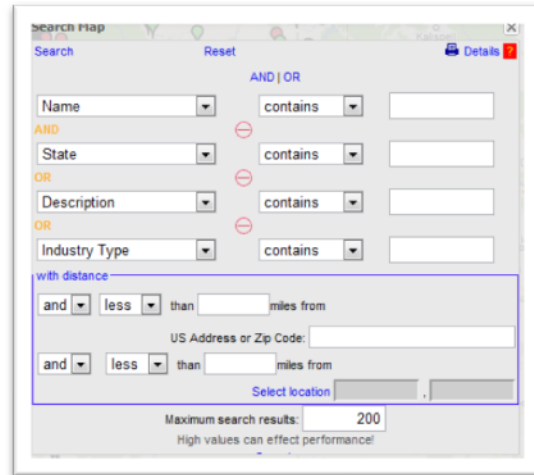

The screenshot shows a search interface titled "Search Map" with multiple criteria. It includes a search bar with a dropdown for "Name" and a "contains" dropdown. Below, there are three criteria sections: "AND State [dropdown] contains [input]", "OR Description [dropdown] contains [input]", and "OR Industry Type [dropdown] contains [input]". Each section has a red minus sign to its left. Below these is a "with distance" section with two rows of distance filters: "and less than [input] miles from" and "US Address or Zip Code: [input] and less than [input] miles from". A "Select location" button is present. At the bottom, it shows "Maximum search results: 200" and a "Search" button.

Figure 3: search box with multiple criteria

APPENDIX 4: Reference File A14 –AWEA2011 Abstract Final

Abstract for AWEA Windpower 2011 Conference:

1. Speaker Information: Brice Barrett, Executive Director; Pacific Northwest Defense Coalition; 2828 SW Corbett Ave Suite 204, Portland OR 97201; Phone - (888) 701-7632; Fax – (503) 517-8095; brice.barrett@pndc.us
2. Bio: Brice earned his bachelor's degree in Political Sciences from Purdue University and his MBA at the Krannert Graduate School of Management. After completing his graduate work, Brice served as a Presidential Management Fellow with the United States Air Force's Space Command in Los Angeles California. During his fellowship, Brice was a Staff Director for the Program Executive Officer for Air Force Space Systems. His time on the PEO staff included work with the Global Positioning Systems (GPS) Program Office and the lead for the Space and Missile Systems Center's Industry Benchmarking Program. Upon completion of his fellowship, Brice stayed on with the Air Force as a Program Manager for a multi-billion dollar communications system acquisition. He has served as Executive Director of the Pacific Northwest Defense Coalition since 2007, and now lives in Portland, OR.
3. Co-Authors: Brice Barrett, Pacific Northwest Defense Coalition; Pam Neal, Portland Development Commission

Topic: DOD funded project leads to additional state and local government leverage in creating supplier database to catalogue and showcase wind supply chain. Because of government support, the database is free to use and available for all companies.

Learning Objectives (150 words max):

- How the Connectory can be an asset to OEMs, wind farm owners/operators, wind farm developers, maintenance, and part manufacturers.
- How to inexpensively leverage government resources to provide a value-added resource for developing supply chains.
- How the NW Connectory can be used diversify procurement. Connectory has the ability to provide info on minority, women, veteran and service disabled veteran owned small businesses.
- How to use the NW Connectory to find suppliers in the Northwest.
- How a supply chain database can be developed in other regions. Learn what resources it is requiring to develop in the NW. (May take this out, include, Learn how to access the strong manufacturing supply base in the NW.

Abstract Body (250 words max):

The Pacific Northwest offers a large base of manufacturing firms with experience in aerospace, high tech and transportation equipment. Those firms are well-positioned to provide services and products for the wind industry and are looking for opportunities to diversify into new markets.

The Northwest Connectory is a web-based buyer-supplier network that provides detailed profiles of firms showcasing products and services as well as technical capabilities to potential customers. As turbines come off warranty, owners and operators now have the ability to look at alternative sourcing for replacement parts and services to reduce costs. The interactive searchable database allows companies to search for quality vetted suppliers. Covering 20% of Oregon manufacturers and an equal number of Washington companies, this database connects the Northwest region and the wind industry.

APPENDIX 4: Reference File A15 – NW Connectory 042611

Slide 1



The Northwest Connector

A new business development tool for the Northwest

April 29th, 2011

Slide 2



What is the Northwest Connector?

- An online buyer-supplier database for *business-to-business* interaction.
 - A Unique way for companies to connect
- A tool for locating detailed company information including specific capabilities, products and services.
- Proven business development tool
 - Promotes companies & fosters business interaction
 - Grows through portals, partnerships

2

Slide 3



Helping Business...

- Respond to economic challenges
 - Identify new markets for core capabilities, capacities
 - Expansion
- Buffer against recession
 - Expand capabilities that cross industries, markets
- Improve proposals & bids
 - Cost competitive
 - Federal bids



3

Slide 4



Businesses that Benefit

- Any business in traded-sector industry
- Cuts across all industry & technology clusters at every level of the supply chain
- Not intended for retail or hospitality industry



4

Slide 5



Industry/Technology Categories

Across Industry Clusters

At every level of supply chain

Manufacturing	Tech/R&D
Product	Construction
Build to Spec	Raw Materials
Industrial Suppliers	Agribusiness
Technical Services	Mining/Quarrying



5

Slide 6



Proven Benefits

- Increased exposure to opportunities
 - ✓ Government contracting/sourcing
 - ✓ Strategic alliances/team building
 - ✓ Corporate buying /subcontracting
 - ✓ International trade
 - ✓ Technology transfer/commercialization
- Communication/networking resource
- Internet presence for underserved firms
- Promotion of regional Industry & technology



6

Slide 7



Benefits for Buyers

- Increases pool of potential suppliers
- Information is deep and wide
- Coverage goal is comprehensive across
 - ✓ industry industrial/technology base
 - ✓ economic regions
- Leverages long term investment
 - ✓ Both public and private
 - ✓ Infrastructure in-place
- Non-Profit "ownership" places high value on inclusiveness
 - ✓ Small firms not precluded by cost
- Expansion ongoing, updates continuous

7

Slide 8



Benefits for Suppliers

- Assess and Define Core Competencies
- Research Potential Customer's Business and Needs
- Identify Potential Strategic Alliance Partners
 - ✓ Complement Strengths
 - ✓ Address Weaknesses
- Place Small Business in Path
 - ✓ Alliance Opportunities
 - ✓ Untapped Markets/Customers/Investors
- Support Marketing, Presentations, Packaging

8

Slide 9



Does it Cost?

- There are no fees to sign up or use the services of the NW Connectory



9

Slide 10



Business Information

Company Info Location, Personnel, Annual Sales, Employees, Year Founded	Capabilities Unique Capabilities/Solutions Applied Technologies Special Materials
Industry Codes SIC, NAICS, NIGP	Staff Expertise Education Experience
Facility/Equipment Make, Model, Quantity, Performance, Capacity	Certifications Quality License
Products/Technologies Proprietary Lines Carried	Customer Base Industry Sectors Geographic Range (Named customers)
	Awards & Affiliations



10

Slide 11



How Does Business Happen?

From a Boeing Program Manager:

“Hi Brice, looking for Served Disabled Veteran Owned Small Businesses (SDVOSBs) in systems engineering, cable manufactures, and light fab. Can you help?”



11

Slide 12



How Does Business Happen?

What Boeing Gets:



12

Slide 13



Building Your Business *Practical Lessons*

- Promoting detailed capabilities
- Performing market research
- Finding new vendors
- Teambuilding



13

Slide 14



Success Story

- Applied Filter Technology used NW Connectory to source parts for their Biogas Filtration systems.
- Connected with Vigor Industrial .
- Resulted in \$750,000 and 10 new Portland-area jobs. Potential annual recurring revenue stream in the millions.



14

Slide 15



Contact Information

Gary Hansen
Pacific Northwest Defense Coalition
(206) 369-8544
Gary.hansen@pndc.us

Link to the Connector:
www.nwconnectory.com

15

Slide 16



Tips for Your Profile

- Pre-made profiles are not as complete
- Google algorithms spider your website for relevancy data
- Keywords rule
- The more detail, the higher your search rank
- Support Marketing, Presentations, Packaging

16



Join the Network

- Fill out and submit an intake form.
- Contact Navindra Gunawardena if you have any questions or you need a copy of the form.
- Respond to the confirmation email you will receive within 1-2 weeks of submitting your form and review your profile.

17

APPENDIX 4: Reference File A16 - OBDD Connectory Training

Slide 1

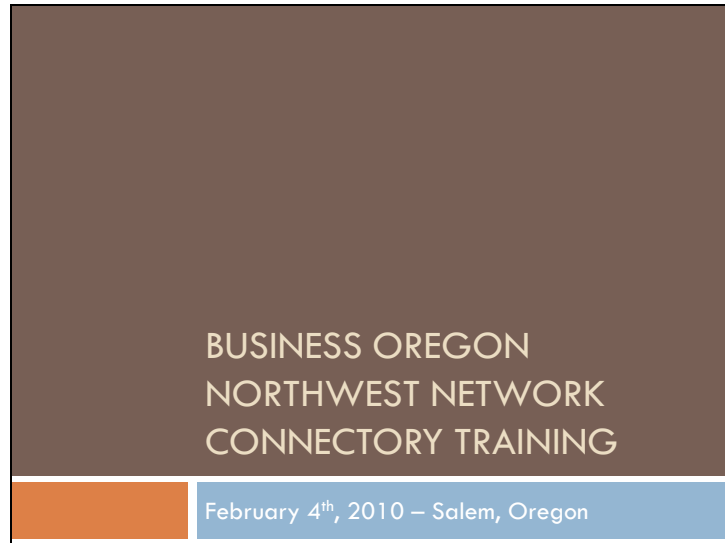

BUSINESS OREGON
NORTHWEST NETWORK
CONNECTORY TRAINING

February 4th, 2010 – Salem, Oregon

Slide 2

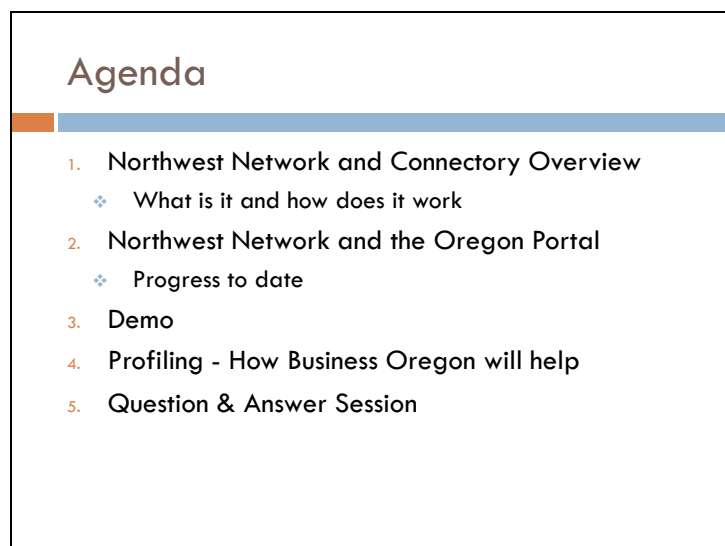

Agenda

1. Northwest Network and Connectory Overview
 - ❖ What is it and how does it work
2. Northwest Network and the Oregon Portal
 - ❖ Progress to date
3. Demo
4. Profiling - How Business Oregon will help
5. Question & Answer Session

Slide 3

What is the Northwest Network

- Pacific Northwest Internet Buyer-Supplier Network
 - ▣ Contains vetted, full-text searchable profiles of companies.
- Proven business development tool
 - ▣ Promotes companies; fosters business interaction
 - ▣ All at **NO COST** to join or use
- Northwest Network is a part of the larger US Connectory which includes over 16,000 companies from California
 - ▣ Live on www.connectory.com as of January 15th, 2010
- Oregon will have a state specific portal
 - ▣ connecting via www.oregon4biz.com.
 - ▣ Set to launch by February 15th 2010
 - ▣ Will include over 500 Oregon companies at launch

Slide 4

What sets the Connectory apart?



- Level of detail – granularity of company profiles
 - ▣ Products/Technologies/Services
 - ▣ Core Capabilities/Competencies & Capacities
 - ▣ Contact/Demographic Info
 - Company names, locations, key personnel, NAICS, web site, email links, size and revenue ranges (Cross-referenced w/CCR)
- Cuts across all industry/technology clusters at every level of supply chain
- Regional in scope, global in reach

*...at **NO COST***



Slide 5

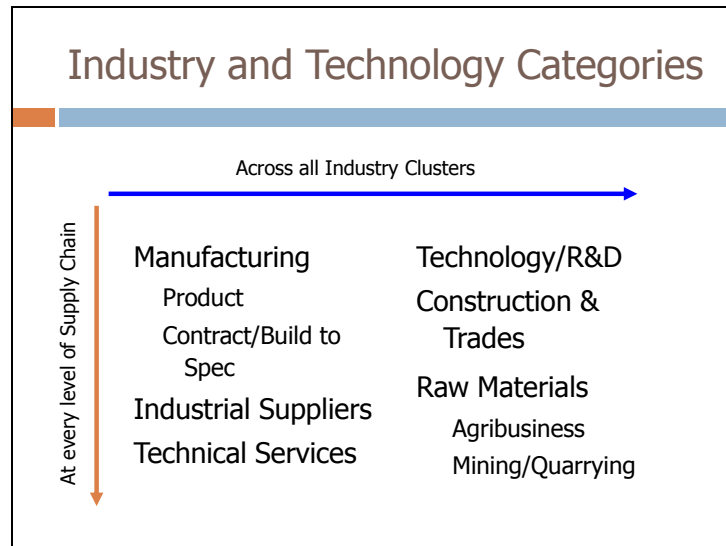

Slide 6

- ### Connectory Features
- Detailed company profiles
 - Database driven architecture (MS SQL SVR)
 - >17,000 profiles in US Connectory as of Jan 2010
 - Search engine powered by mini-Google
 - GIS capability
 - Interactive, web-based map application
 - Dynamic features
 - Profile intake application with "tailored" help text
 - Company "owns" its profile
 - "Spider" to ease profiling (potential for data mining)
 - Auto Updates -- Keeps database current
 - Resource pages/links

Slide 7

Benefits for Buyers

- Increases source pool of potential suppliers
- Information available is deep and wide
- Coverage goal is comprehensive across:
 - Oregon industry industrial/technology base
 - Oregon's economic regions
- Leverages long term investment
 - Both public and private
 - Infrastructure in-place
- Non-Profit "ownership" places high value on inclusiveness
 - Small, disadvantaged firms not precluded by cost



Slide 8

Benefits for Suppliers

- Assess and Define Core Competencies
- Research Potential Customer's Business/Needs
- Identify Potential Strategic Alliance Partners
 - Complement Strengths
 - Address Weaknesses
- Place Small Business in Path of Alliance Opportunities
- Untapped Markets/Customers/Investors
- Support Marketing, Presentations, Packaging



Slide 9

Supports Economic Development



- Company Contact Outreach/Management
- Cluster/Sector/Gap Analysis
- Site Surveys/Trade Shows
- Business Attraction, Retention & Expansion
- Company/Community Inquiries
- Workforce Development
- Tech Sector Talent Needs Assessment
- Consortium/Alliance Development
- Strategic/Program Planning
- Inclusion of Underserved Areas



Slide 10

Proven California Connector Benefits

- Increased exposure to opportunities
 - ▣ Government contracting/sourcing
 - ▣ Strategic alliances/team building
 - ▣ Corporate buying (JIT)/subcontracting
 - ▣ International trade
 - ▣ Technology transfer/commercialization
- Communication/networking resource
- Internet presence for underserved firms
- Promotion of regional industry/technology



Slide 11

US vs. Northwest Network vs. Oregon Portal

- US Connectory contains 17,000+ profiles predominantly in California
- Northwest network is the subset of profiles in the Connectory within Oregon, Washington, Idaho, Montana, Alaska and Hawaii.
- Oregon Portal contains the Oregon specific profiles within Northwest Network.
 - ▣ Accessible only through Business Oregon website

Slide 12

Progress to Date

- Northwest Network is live as of January 15th 2010.
 - ▣ Northwest Network Portal has over 800 profiles
 - ▣ Accessible via Connectory.com
- Oregon Portal to launch on February 16th, 2010
 - ▣ Over 500 Oregon companies profiled
 - ▣ Includes an Oregon specific search engine embedded in OBDD website along with pop out interactive map

Slide 13

Unique data fields

- Full text searchable profiles
- NAICS codes, Industry sectors
- Location
- Quality Certifications (ISO, AS9100, ASTM)
- Owner Certifications (Small business, women-owned, HUBzone, etc)
- License certifications (Food processing, Contracting)

Slide 14

GIS Capability

- Interactive web-based map application
 - ▣ Northwest network portal on connectory.com
 - ▣ Business Oregon website
- PDF maps
 - ▣ Congressional districts
 - ▣ County
 - ▣ Oregon Senate and House districts.
 - ▣ Currently only Metro areas

Slide 15

Pause for Demo

- Northwest Network Portal Page
- Highlight search capabilities
- GIS interactive map

Slide 16

Profile Development Methods

1. Company logs onto Connectory.com and creates own profile
2. Partner works with company to fill out intake form which is then used by profiler to create profile.

Slide 17

How Business Oregon will help

- Outreach to associated companies
- Educate and inform companies on Connectory
- Generate “buy-in” for using Connectory and building complete profiles

Slide 18

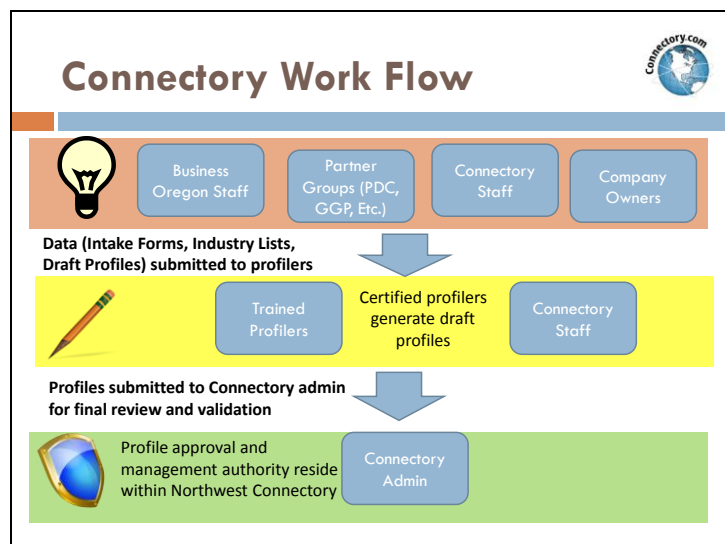

Slide 19

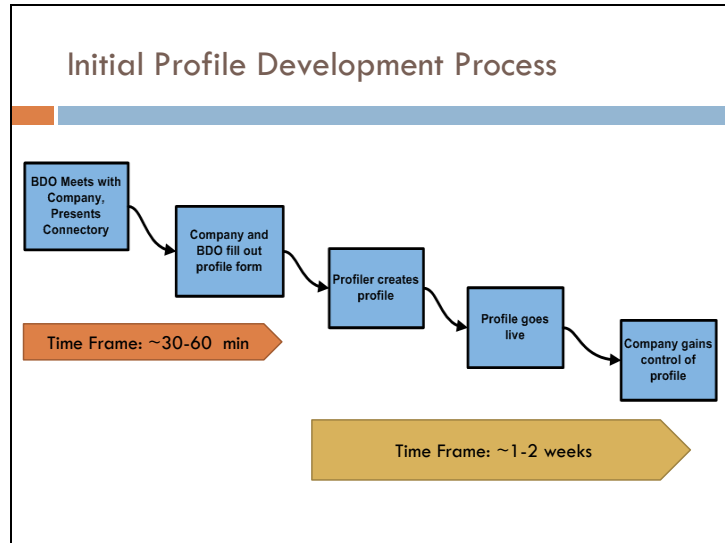

Slide 20

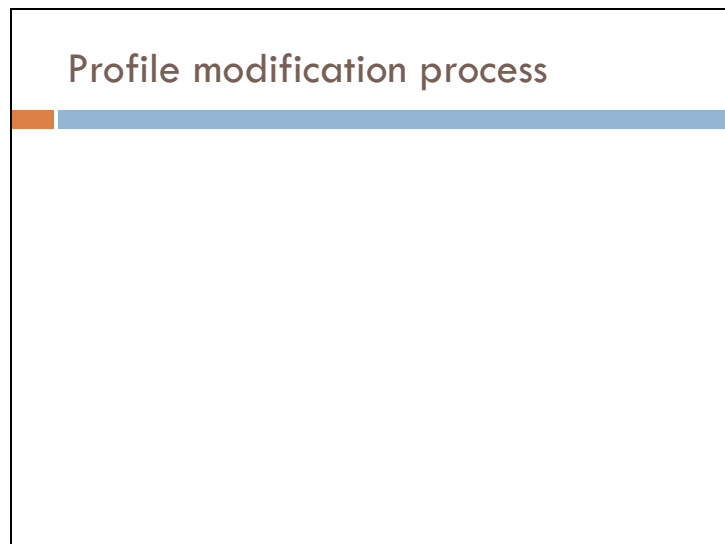

Slide 21

Company approval and ownership

- Once profile goes live, Company owns the profile.
- Given login and password. Sent to contact email.
- Able to modify profile as they see fit.
- Changes are reviewed by Connectory Profiler prior. If changes are made, company is notified.
- Company is queried every year by Connectory to updating profile

Slide 22



A project of the
Pacific Northwest
Defense Coalition

- 2828 SW Corbett Avenue, Suite 115, Portland, OR
- Tel. (503) 725-2384
- Fax (503) 725-2383
- www.connectory.com
- Navindra@pndc.us

Slide 23

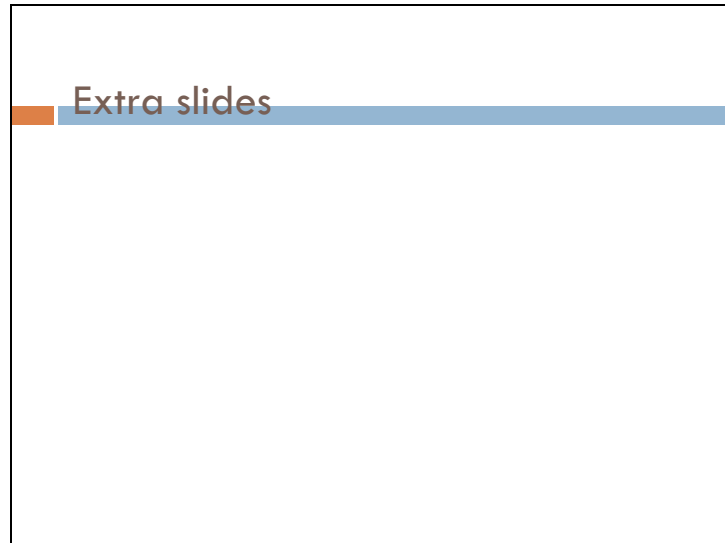

Slide 24

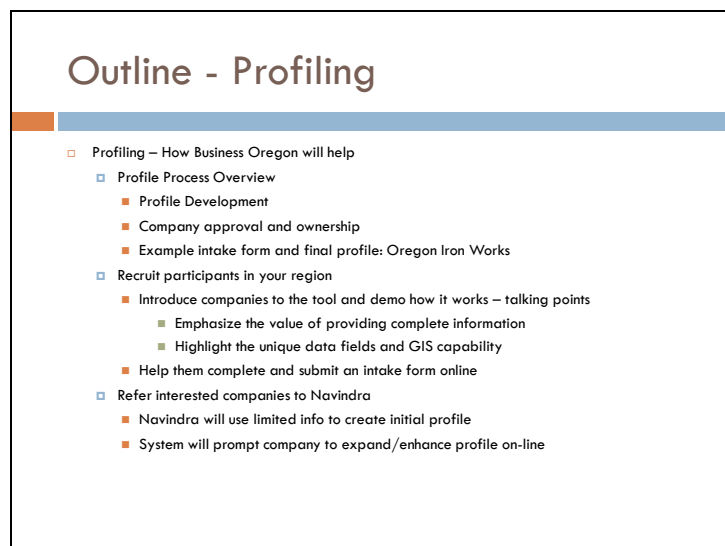

Slide 25

What is Connectory.com®?

Internet Buyer-Supplier Network

- B2B tool -- Unique way for companies to connect
- Proven business development tool
 - ▣ Promotes companies; fosters business interaction
 - ▣ All at **NO COST** to company
 - ▣ Growing through portals, partnerships



Slide 26

Connectory.com Northwest Network and Business Oregon

Training - February 4th, 2010

Connectory.com Northwest Network and Business Oregon

February 4th, 2010



Slide 27

Example intake form and final profile: Oregon Iron Works

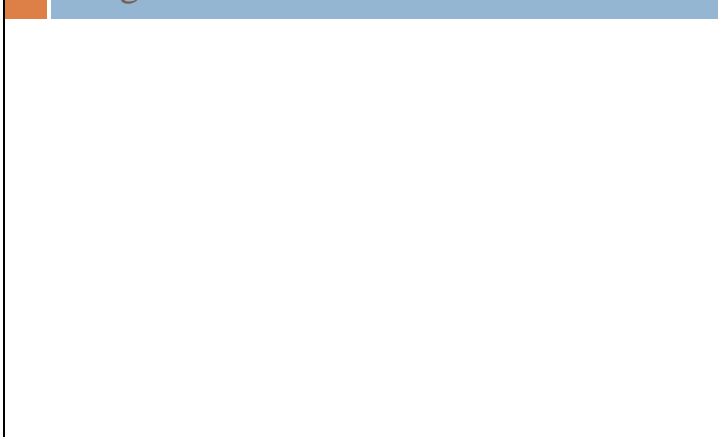

Slide 28

Defining Connectory.com® Coverage - NAICS

1. Manufacturing	Sector 31, 32, 33 (no tobacco mfg.)	Product (proprietary), OEM, &Contract (Build to Spec) Mfg.
2. Technology / R&D	Products- Sector 31-33; 51, Information, Sector 54 – Scientific & Professional Services	Firms develop/license technologies but do not manufacture
3. Industrial Suppliers	Sector 421 - durable goods, 422 – non-durable	Supplier focus; NOT <u>retail</u> .
4. Technical Services	Sectors 51 – Info, 54, Scientific & Professional, 48 – Transportation & Warehousing	NOT Personal services
5. Construction & Trades	Sector 23 - Construction	Contractors License required
6. Raw Materials: Agribusiness & Mining	Sector 11 – Agribusiness Sector 21 - Mining	Relatively recent addition to coverage

Slide 29

Baseline Profile – Required Fields

<ul style="list-style-type: none">Company NameAddress (physical)<ul style="list-style-type: none">Street/Suite, City, ZipCountyTelephoneKey Personnel/POC<ul style="list-style-type: none">At least oneSIC or NAICS code<ul style="list-style-type: none">At least one	<ul style="list-style-type: none">Company Description<ul style="list-style-type: none">a.k.a Elevator SpeechWeb SiteEmail AddressYear EstablishedNumber of Employees<ul style="list-style-type: none">Range onlyLocal & Corporate
-----------------------------------------------------------------------------------------------------------------------------------------------------------------------------------------------------------------------------------------------------------------------------------------------------------------------------------------------------------------------------	------------------------------------------------------------------------------------------------------------------------------------------------------------------------------------------------------------------------------------------------------------------------------------------------------------------------------

Required! 

Slide 30

Connectory.com® Profile Fields

<ul style="list-style-type: none">Company Info<ul style="list-style-type: none">Location, Personnel, Annual Sales, Employees, Year FoundedIndustry Codes<ul style="list-style-type: none">SIC, NAICS, NIGPFacility/Equipment<ul style="list-style-type: none">Make, Model, Quantity, Performance, CapacityProducts/Technologies<ul style="list-style-type: none">ProprietaryLines CarriedCapabilities<ul style="list-style-type: none">Unique Capabilities/SolutionsApplied TechnologiesSpecial Materials	<ul style="list-style-type: none">Staff Expertise<ul style="list-style-type: none">ExpertiseEducationExperienceCertifications<ul style="list-style-type: none">QualityLicenseOwnershipCustomer Base<ul style="list-style-type: none">Industry SectorsGeographic RangeDescriptions (named customers)Awards & Affiliations
--------------------------------------------------------------------------------------------------------------------------------------------------------------------------------------------------------------------------------------------------------------------------------------------------------------------------------------------------------------------------------------------------------------------------------------------------------------------------------------------------------------------------------------------------------------------------------------------------------------------------------------------------------------	-----------------------------------------------------------------------------------------------------------------------------------------------------------------------------------------------------------------------------------------------------------------------------------------------------------------------------------------------------------------------------------------------------------------------------------------------------------------------



Slide 31

Why Connectory.com®?

- Response to economic challenge
 - Recovery from post cold war recession
 - Identify new markets for core capabilities, capacities
 - Expansion correlated to success, need
- Flourished in California's decade of growth
- Recession proofing against slow downs
 - Capabilities that can cross industries, markets
 - Goal: Capture industrial/technology base of California
- Tapped to identify technology sources for defense & homeland security
- Virtual Platform for WIRED – Economic and Workforce Development



Slide 32

Interactive map screenshot

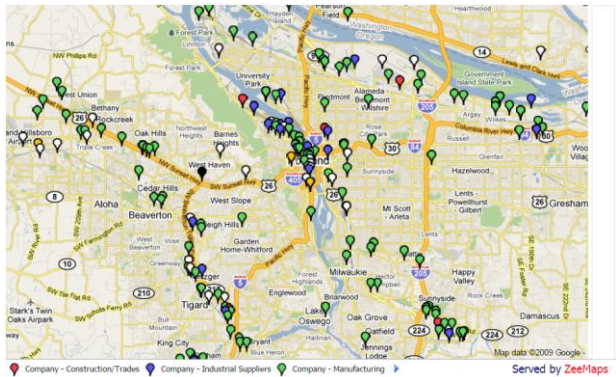

Slide 33

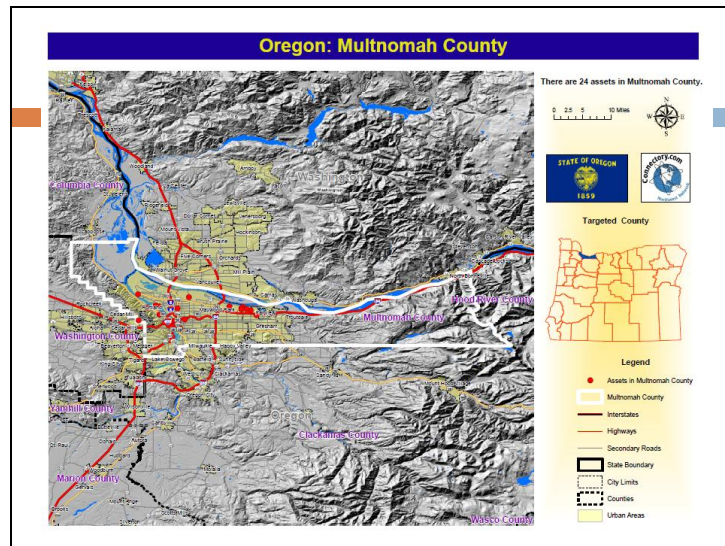

Slide 34

Name	Street Address	City	ZIP	Industry Type
AmFor Electronics	5061 N Lagoon Ave	Portland	97217	Manufacturing
Associated Powertrain	4436 NE 158th Ave	Portland	97230	Manufacturing
Brake Systems Inc	2221 NE Hoyt St	Portland	97232	Manufacturing
Cabin Air Technologies LLC	1132 SW 19th Ave	Portland	97205	Technology/R&D
Danner Boots	17634 NE Airport Way	Portland	97230	Manufacturing
Erickson Air-Crane Incorporated	5550 S.W. Macadam Avenue	Portland	97239	Manufacturing
Indepak	2136 NE 194th Ave	Portland	97230	Manufacturing
Industrial Craters and Packers	3509 NW St Helens Rd	Portland	97210	Construction/Trades
Integrated Inspection Systems	2429 SE 11th Avenue	Portland	97214	Technical Services
Northwest Alliance Group	377 NW 81st Place	Portland	97229	Technical Services
Northwest Naturals, Inc	4050 NE 158 Ave	Portland	97280	Manufacturing
Portland Precision Manufacturing Co.	16327 NE Cameron Blvd	Portland	97230	Manufacturing
Sherpa Design	6700 N New York Ave	Portland	97203	Technical Services
Simplex Manufacturing	13340 NE Whitaker Way	Portland	97230	Manufacturing
Small Parts Manufacturing	4401 NE MLK Jr Blvd	Portland	97211	Manufacturing
Thortex	15045 NE Mason St	Portland	97230	Manufacturing
Tubular Solutions Inc	2690 NW Nicolai St	Portland	97210	Manufacturing
U.S. Barge	5555 N Channel Ave	Portland	97217	Manufacturing
Unisource Manufacturing	8040 NE 33rd Dr	Portland	97211	Industrial Suppliers
Urban Robotics	33 NW 1st Ave	Portland	97209	Manufacturing
URS Electronics	123 NE 7th Ave	Portland	97293	Industrial Suppliers
VideoPresence	921 SW Washington Street	Portland	97205	Manufacturing
Vigor Marine	5555 N Channel Ave	Portland	97217	Manufacturing
WRS Financial	222 SW Columbia	Portland	97201	Technical Services

APPENDIX 4: Reference File – NW Connectory Related Activities - 052611

Summary of all NW Connectory related activities – May 25th, 2011

Since going live in January of 2010, the Northwest Connectory has grown to include nearly 4,000 companies in 6 states.

Breakdown by State:

- Alaska = 8
- Hawaii = 12
- Idaho = 21
- Montana = 22
- Oregon = 1852
- Washington = 1876

Profiling was done by Justin Jangraw, Navindra Gunawardena and ECEDC Staff. Justin Jangraw profiled PNDC companies. In addition to directly creating profiles, Navindra focused on obtaining lists of companies from partners, and then worked with ECEDC staff to have those lists profiled.

Sources of lists include:

- Oregon Business Development Department
- Portland Development Commission
- Pacific NW Aerospace Alliance
- Northwest Environmental Business Council
- Oregon Solar Energy Industry Association
- SBA Dynamic Small Business Search database
- Oregon Wave Energy Trust
- Oregon Manufacturing Extension Partnership

A Connectory profile intake form was created and distributed. That was used by companies to directly send in information which was then used to create a profile. See included file A1.

Paid Sponsorships were given by both the Oregon Business Development Department (OBDD) and Portland Development Commission (PDC). The OBDD sponsorship paid an Oregon specific portal within the NW Connectory, as well as hiring Navindra Gunawardena as a project manager for entering companies into the database and promoting the database.

PDC contributions paid for the creation of custom printed marketing materials for the NW Connectory including:

- Pens
- Mugs
- Mouse pads
- Promotional Folders

- Marketing handouts
- Sticky Notes
- Trade show booth panels
- Pop-up banners

Brice Barrett and Navindra Gunawardena promoted the NW Connectory at numerous events including networking sessions, conferences and trade shows. Highlight of events:

- Oregon Economic Development Association – Spring 2010 meeting
- Oregon Economic Development Association – Fall 2010 meeting
- NEBC Future Energy Conference – March 2010
- NEBC Future Energy Conference – March 2011
- Alliance 2010
- Alliance 2011
- PNDC Bremerton NW Defense symposium
- American Wind Energy Association (AWEA) Trade Show – May 2010
- AWEA small wind trade show
- Navy Goldcoast
- PNAA conferences in 2010 and 2011

Promotions include presentations and trade show booths.

Steering Committee for guiding the NW Connectory was setup in Summer of 2010. Included members from OBDD and PDC. Purpose was to include partners and build a committee to advise and guide direction of Connectory. Meetings were held monthly in from June 2010 till Dec. 2010. See meeting minutes. See files A2 – A5.

NW Connectory Electronic newsletter was created using Constant Contact. Was sent out in Feb. 2011, Dec. 2010 and Oct. 2010. See Files A6 – A8.

Success Stories (see printed materials):

- Vigor and Applied Filter technology partnership
- Lockheed vetting Last US Bag
- See files A9 and A10

Representation of Large companies in Connectory proposal – See File A11

Oregon Key Industries and the NW Connectory Document – This is an analysis done by Navindra of Oregon companies in the NW Connectory. The focus is the distribution of companies along Key industries defined by the Oregon Business Development Department. See File A12 for more details.

Connectory Search report – This report was an analysis of how the search capabilities behaved when searching for multiple Zip or NAICS codes. Changes to the search features were proposed at the end of the report. See File A13.

Other included files of interest:

- A14 – Abstract submitted for AWEA 2011 show
- A15 – NW Connectory Presentation
- A16 – OBDD Training Presentation

Appendix C – Portland State University Final Report

**"Northwest Manufacturing Initiative"
NWMI Grant No. W911NF-08-1-0046**

**Final Technical Report
Portland State University
PO Box 751-ME
Portland, Oregon 97207**

**Principal Investigator
William E. Wood
Professor, Dept of Mechanical and Materials Eng**

**Report date
June 2011**

Contents

Foreward

PART A: Electrospark Deposition and Ultrasonic Impact Treatment

A1. Introduction	6
a. Electrospark Deposition	
b. Ultrasonic Impact Treatment	
c. Fatigue behavior	
A2. Objectives	6
A3. Technical Approach	8
a. Electrospark deposition	
b. Integrated electrospark deposition and ultrasonic impact treatment	
c. Fatigue properties Assessment	
d. Materials Characterization	
A4. Experimental Methods	11
a. Materials	
b. Surface treatment parameters	
c. Analysis methods	
A5. Results	20
a. Ultrahigh strength steel alloys tensile properties	
b. Electrospark deposition	
c. Microstructural analysis	
d. Microhardness	
e. Nano indentation	
f. Residual Stress	
g. Fatigue	
A6. Discussion	27
A7. Conclusions	32
A8. Bibliography	33
A9. Acknowledgements	34
A10. List of Tables and figures	35
A11. Tables and Figures	38
A12. Appendix	83

PART B: Fracture toughness, Fatigue Crack Propagation and Threshold Stress Corrosion Cracking Sensitivity

B1. Introduction	129
B2. Experimental Methods	129
a. Materials and specimen preparation	
b. Heat treatment	
c. Mechanical property evaluation	
d. Acoustic emission monitoring	
e. Microstructural analysis	
B3. Results	133
a. Mechanical properties	
b. Microstructure	
c. Fractography	
B4. Discussion	136
B5. Conclusions	136
B6. Acknowledgements	137
B7. List of tables and figures	138
B8. Tables and figures	140

Foreward

Many structural components in aerospace and high performance structures make extensive use of ultra high strength steels such as alloy 4340 and 300M. These alloys however exhibit little corrosion resistance, are susceptible to hydrogen induced delayed cracking, and often require protective coatings. Often very small localized damage may require the component to be replaced in the absence of approved repair procedures. Field repairs are not considered. There are a number of alternative procedures for repairing damaged surfaces but the repairs usually require technologies that induce distortion, result in a heat affected zone with degraded properties and a repair with questionable microstructures and suspect properties.

Electrospark deposition (ESD) process has been developed as a coating technology and applied for wear resistance, corrosion resistance, for build-up and special surface modifications. It's use has not been generally targeted for repairs to structural components. ESD employs short duration, high current electrical pulses to deposit consumable electrode material. It produces a fused bond, while requiring a low heat input. It can, depending on how it is applied, result in a extremely small substrate heat affected zone. This process creates a metallurgical fusion bond to substrates and displays superior adhesion. Rapid solidification results in unique micro and nano structures. Substrates with non-line-of-sight surfaces that are inaccessible with other repair procedures can be ESD treated.

The ultrasonic impact treatment process, UIT, applies a 27 kHz high intensity impact treatment to directed areas and, when applied to ESD deposits, plastically deforms the ESD layer and its localized heat affected zone. Importantly it acts to smooth the topography of the ESD deposit and increases deposition rates. UIT imparts a high level of compressive residual stress in the deposit and into the heat affected zone/substrate. Integration of ESD and UIT technologies significantly enhance the ESD deposition process inducing high levels of compressive stresses and enhanced surface hardness.

Due to the limited corrosion and hydrogen delayed cracking resistance of 4340 and silicon modified 4340,300M, conventional ultra high strength alloys, new corrosion resistant ultra high strength steel alloys have been developed. Two such alloys are Custom 465 and Ferrium S53 quenched and aged and quenched and tempered respectively. C465 is a precipitation hardening low carbon martensitic stainless steel and the S53, a secondary hardening highly alloyed martensitic steel. Relative to the conventional alloys there is little published data available that assesses their fracture toughness, fatigue crack growth and stress corrosion cracking behavior. This project was designed to evaluate the fracture toughness, fatigue crack growth and stress corrosion cracking threshold stress intensities of these new alloys relative to conventional alloys and to also evaluate electrospark deposition and integrated ultrasonic impact treatment surface modifications to the conventional and to these new advanced alloys.

Part A of this report includes the characterization of ESD and integrated ESD/ UIT deposit, the resulting heat affected zone, and the mixing layer of the deposit electrode chemistry with the ultrahigh strength steel substrate through micro hardness measurements and micro-structural and micro-chemical characterization of the heat affected zone using SEM, TEM, optical microscopy techniques, and x-ray depth profiling residual stress analysis. The fatigue life properties under both low and high cycle fully reversed bending tests were determined for the baseline alloys and for ESD and ESD integrated with UIT.

Part B of this report includes the fracture properties of conventional 300M steel as well as the fracture properties of the newer corrosion resistant ultra high strength steels, Custom 465 and Ferrium S53. Results for C465 aged at 950°F and at 1000°F are included. Plane Strain fracture toughness, fatigue crack growth versus applied stress intensity range, and threshold stress corrosion cracking stress intensity levels for each alloy were determined using a rising step load test method modified to incorporate acoustic emission analysis as well as load drop to determine the onset of cracking. Acoustic emission testing was used to detect early crack growth threshold stress intensities and to supplement conventional RSL load drop criteria.

PART A:Electrospark Deposition and Ultrasonic Impact Treatment

A1. INTRODUCTION

a. Electrospark Deposition (ESD)

The Electrospark deposition (ESD) is a micro-arc welding process that uses short duration, high current electrical discharge pulses to deposit an electrode material onto a metallic substrate. This process produces a metallurgically bonded coating with a low heat input. The bulk substrate material remains at or near ambient temperatures, depending on specific deposition procedures, eliminating major changes in substrate metallurgical structure. The short duration pulse melts both the electrode and substrate to which the droplet is transferred, resulting in the micro-volumes of electrode material fused into the substrate surface forming a metallurgical bond [1-9]. Many such volumes or splats overlap to form a complete coated layer on the substrate. Since each splat is about 5-10 μm thick, a multi layer build up is required even for very thin repairs. As the deposition process is continued a very thin diffusion or mixing layer is formed at the boundary between the deposited material and the substrate. The subsequent layers rapidly diminish the effect of this mixing layer as the heat produced during further deposition cannot penetrate through these already deposited layers and the coating approaches the electrode composition. Additionally, the repeated molten droplet transfer and the arc discharge results in a sharp thermal profile within a very narrow region, resulting in residual stresses in the coating and the narrow heat affected zone. The ESD process can be applied to conductive metal substrates and has been demonstrated on components of low and medium carbon steels, tool steels, die steels and mold alloys, cast irons, cast steels, stainless steels, aluminum alloys, copper alloys and titanium alloys. Electrical conductivity is the key property that dictates the capability to use ESD process on a part repair or coating. The ESD process can be applied to some alloys that are considered to be un-weldable due to cracking susceptibility in the deposit and substrate. The bond produced by the deposit material to the substrate is a metallurgical fusion bond and not a mechanical bond. The basic disadvantage of ESD process is that the deposition rate is low. The production of discrete deposits during each discharge event results in the transfer of very small volumes of material. As the thickness of the deposit increases the surface roughness increases. Some of these deposits, up to 50%, are removed however during periodic surface smoothing steps using abrasive grinding to avoid excessive surface roughness which can result in bridging type porosity.

b. Ultrasonic Impact Treatment (UIT)

The Ultrasonic impact treatment (UIT) induces high level compressive stresses and depending on the substrate can result in work hardening the surface and near surface layer. This process is noted for improving the reliability of welded joints and fatigue strength and used in the U.S. and internationally for enhancing fatigue resistance of weldments. Developed in Russia in the early 1970s, this process is widely used for enhancing the fatigue and fabrication of welded

structures. Some of the advantages of UIT include portability, site specific application, high over and ease-of-use of the tools [10-20]. The ultrasonic impact treatment induces ultrasonic vibrations at the ultrasonic transducer output end coupled to a hard material which is then coupled by direct contact with the surface to be treated. A relatively thin depth of the treated material is plastically deformed. Residual compressive stresses are induced to significantly greater depths.

In the early 1970's E.Sh.Statnikov proposed a modified method of ultrasonic impact treatment that employs free needle indenters as impacting elements that move along the axis of the oscillating system and have a normalized wavelength relative to the carrier ultrasonic frequency [10,13]. The system used for the current research used a single pin technique to enhance research procedure reproducibility. Production implementation would likely use multiple impact pins to optimize efficiency. The methodology and treatment procedures used for Portland State University research were based on methods proposed by E.Sh.Statnikov in the late 1990's and early 2000's [11-12,14-20] resulted in the Esonix technology and UIT system used for this research project.

c. Fatigue behavior

Historically ESD has been applied predominantly for repair of worn surfaces or to enhance wear resistance of surfaces, as a thin coating, usually containing a high volume of hard carbides, similar to a hard facing weld deposit. These high hardness coatings typical contain cracks but their purpose is to provide a wear resistant coating rather than a repair as an integral structural element. There are only two known studies that evaluated fatigue behavior of ESD onto aircraft type high strength alloys, [21,6] The first applied ESD onto heat treated 4340 round tensile type tension-tension fatigue samples and the second applied ESD onto heat treated nickel base superalloys and martensitic stainless steel flat tensile coupons containing small divots which were filled using ESD. The first study rotated the round tensile coupon while positioning the ESD electrode to deposit a 0.003inch ESD buildup in the middle, in a reduced section. The continuous nature of the deposition onto a rotating sample can result in high levels of heat build up in the electrode tip and in the substrate. For 4340 this can result in significant softening and width of the HAZ. For the flat tensile containing a shallow divot, filled with ESD using a manual deposition process onto alloy 718, the heat buildup in the substrate and in the alloy 718 electrode was minimized. The high temperature stability of alloy 718 is much more resistant to ESD induced HAZ tempering than 4340.

Since the ESD deposit made with a matching 718 electrode exhibited an as deposited HRC 38 Rockwell hardness compared to the heat treated substrate hardness of HRC43, the ESD deposit had lower yield strength than the substrate, less than the maximum applied stress during the low cycle fatigue tests. Both the 4340 and In718 alloys and test configurations demonstrated major reductions in fatigue strength compared to the substrate alloys. Both were tested in the as deposited condition without any post deposit heat treatment. In a follow on study on In718 and 410SS [6,7] ultrasonic impact treatment (UIT) was applied after several intermediate layers and

after the ESD was completed. The UIT was initially done to evaluate the effect of ESD interlayer UIT treatment on deposition rates, by smoothing the ESD surface and eliminating interlayer ESD grinding. However the well known effect of UIT on fatigue enhancement in weldments resulted in additional fatigue tests on flat tensile coupons with manually ESD filled divots treated by manual UIT treatment. The results demonstrated significant fatigue property improvement by introducing high levels of compressive stresses in the ESD deposits, which otherwise contained high levels of tensile residual stress. The surface plastic deformation of the ESD deposit also increased the deposit hardness, HRC38 for as deposited Alloy 718 onto alloy 718 increased up to HRC 43. Hardnesses up to HRC 48-50 can be achieved by UIT treatment of alloy 718. Both contributed enhanced hardness and modified residual stress levels contributed to a major improvement in fatigue strength. The objective of the present effort is to extend this concept to application of ESD/UIT onto ultrahigh strength alloys with yield strengths above 220ksi and to characterize the ESD deposit and the underlying heat affected zone in the as deposited and in the ESD/UIT conditions.

A2. OBJECTIVES

a. Characterization of ESD heat affected zone of ultrahigh strength steel alloys

Conventional quench and tempered martensitic UHSS alloys are very temper sensitive and may be embrittled or rapidly softened or re-solutioned and quenched depending on the HAZ thermal cycle. ESD is unique in that the arc discharge is measured in microseconds and the per splat quenching rate is very high. Pulse rates on the order of 400hz and a moving and rotating electrode combine to create a complex thermal cycle. One objective of this project was to characterize the ESD induced HAZ.

b. Evaluate the applicability of ESD on corrosion resistant ultra high strength steel.

New generation ultra high strength corrosion resistant steel alloys have extensive alloying additions for corrosion resistance and have adopted alternative, to conventional quench and tempered UHSS such as 4340, alloy design principles. Two alloys were selected for ESD HAZ development study, Custom 465, a low carbon quench and aged (between 950°F and 1000°F for 4 hours) alloy and Ferrium S53, a medium carbon secondary hardening steel that forms complex alloy carbides after double tempering between 934°F and 900°F. Both of these UHSS alloys require 4 hours above 900°F to optimize high strength levels. An objective of this project is to characterize the structure and properties of their ESD HAZ. Their fundamental strengthening mechanisms may result in a significantly different ESD HAZ than those formed in conventional alloys such as 4340.

c. Influence of UIT on ESD deposit and HAZ properties

Ultrasonic impact treatment when applied to ESD deposits plastically deforms the ESD layer and its localized heat affected zone and imparts a high level compressive residual stresses in the deposit, its heat affected zone, and into the base material substrate. In addition the UIT

process can reduce porosity type defects in the ESD and lead to hardness increases in both the ESD deposit and in the HAZ. The objective of this research was to evaluate, quantify, and optimize the influence of UIT on the ESD deposit and HAZ in conventional and corrosion resistant UHSS.

A3. TECHNICAL APPROACH

a. Electrospark deposition (ESD)

For this research it was of interest to examine the electrospark deposit weld dilution transition region occurs within the first 3 electrospark deposit layers and the HAZ between the coating and substrate, also to make a determination of its metallurgical structure, as well as the deposited material's hardness and fatigue behavior over both low and high cycle fatigue life regions.. Optimization of the ESD process, integral with the choice of electrode material, was the first program element addressed. ESD processing parameters must match the deposition characteristics of the electrode and substrate combined alloy system. Portland State University used an Advanced Surfaces and Processes Inc, (ASAP), ESD system configured with both selectable rotational as well as oscillation/rotational electrode motion. Advanced Surfaces and Processes Inc provided guidance for using both matching electrode/substrate and Stellite 21 electrode ESD parameters. Fully heat treated, (Rockwell C hardness levels at least HRC52) test coupons of several ultrahigh strength low alloy steel substrate alloys were prepared and ESD deposits with varying parameters were evaluated to determine the optimum ESD parameters. Process optimization is based on analysis of the resulting deposit in terms of porosity, splat to splat bonding, splat bridging defects. ESD selectable process parameters include voltage, capacitance, amperage, electrode contact force, rotational speed, travel direction with respect to rotational direction, percent overlap per each pass, layer to layer 90 degree rotation, "smoothing deposit arc splat peaks" by sanding or impact treatment between groups of layers, gas shielding, electrode extension, and electrode tip angle dressing. A well documented ESD procedure specification must include each of these parameters.

While ESD is usually applied manually using a hand held rotating electrode torch, for consistency and reproducibility PSU added a Motoman 5 axis robotic system and an integrated automated ultrasonic impact treatment system in order to ensure consistent ESD operating parameters and comparable ESD deposit characteristics on each substrate. For this reason a single electrode composition was used. In order to achieve a high hardness with good corrosion resistance in the as deposited condition Stellite 21 electrode was chosen to apply to all alloys using the same ESD deposition parameters. For comparison purposes initial activities also included electrode-substrate matching compositions, i.e. alloy 300M electrode deposited onto alloy 300M substrate. The rapid tempering response of the alloy splat deposits combined with the austenite to ferrite martensite phase transformation during splat quench cooling presents major deposit quality limitations.

b. Integrated ESD and UIT

This program integrated two established technologies, UIT and ESD to enhance the deposition characteristics of the ESD process and to improve the resulting deposit characteristics. While both technologies are typically done using hand held manual techniques, this program adopted automated and integrated methods to enhance reproducibility and consistency. Key UIT variables were evaluated in terms of hardness profiles aimed at producing a deposit, heat affected zone, and substrate with closely matching hardness. Pin diameter, UIT intensity levels, and travel speed are the operating variables routinely varied and those varied in this program.

c. Materials characterization

The heat affected zone formed as a result of multilayer ESD deposition is one of the main focuses in this project. In addition to microstructural evolution in the ESD and the HAZ, hardness profiles provide key complementary insight into both regions as well. The relatively small thickness and width of the deposit and its HAZ restricts hardness evaluation to low load level microhardness (25gm force) and to nanoindentation methods to detail the hardness profile in the narrow HA, about 10-20 μ m thick. Using both techniques it is possible to map the difference in hardness from the substrate interface HAZ to the top of the ESD deposit. While higher load type hardness measurements can assess overall integrated deposit hardness for these hard deposits, any gradient from top to bottom, using top down hardness measurements would be masked. The combination of high hardness and low microhardness indent loads resulted in Knoop indent lengths and widths small enough to measure hardness changes across the ESD deposit and to obtain at least one hardness value in the 10-20micron wide HAZ.

The sharp thermal pulses characteristic of the ESD process will result in localized tempering on conventional as-quenched UHSS martensitic alloys fundamentally sensitive to carbide precipitation during tempering. The ESD induced HAZ in conventional UHS steel and can be seen using conventional etching methods. The precipitation hardening ultrahigh strength steel alloys however are soft in the as quenched condition and develop their strength by a high temperature aging treatment from 900-1000 $^{\circ}$ F (475-570 $^{\circ}$ C) and require several hours at these temperatures to achieve optimum tensile and fracture properties through precipitation strengthening. The ESD process does not develop holding times consistent with those required to age or overage these materials. Also, the distance from the fusion line at which the temperature would reach the precipitation temperature is extremely narrow. This combination results in a HAZ structure that requires high resolution SEM and TEM to study the fine microstructure in this narrow HAZ.

Conventional electropolishing techniques for preparation of TEM samples was not possible due to both the sharp chemical differences between the ESD deposit and the substrates and because the HAZ region of interest was only microns thick. The thin foil sections of the selected regions at the interface including the transition region, the first and second ESD layers and the HAZ were prepared using Focused Ion Beam Milling (FIB) system.

Residual stress analysis of the ESD deposition and UIT treated region was done by XRD technique at PROTO Inc. Depth profiling of the residual stresses was done by iterative chemical milling between x-ray analyses on the same area to determine residual stress as a function of depth from the surface. Samples were prepared by PSU and locations marked on the coupons for depth profiling residual stress analysis.

d. Fatigue Properties Assessment

Past PSU research evaluating ESD and ESD/UIT used small flat tensile coupons .250inch wide and 0.1inch thickness with a small divot 0.125inch in diameter in the center of the 1 inch gage length. These were prepared for tension-tension fatigue testing using an R ratio of 0.05. The small circular divot was ESD treated manually by Advanced Surfaces and Processes and UIT was applied to the small ESD region in the narrow gage length. This small repair area on a sample width slightly larger than the repair made consistent UIT difficult. The very small cross section of the tensile coupon resulted in a very small substrate heat sink which under manual application can be compensated for by intermittent pauses in application to avoid excessive heating. In consideration of these limitations and in recognition that a larger ESD and ESD/UIT test area would provide a larger volume and surface area for fatigue cracks to initiate, a flat tapered constant stress fully reversed loaded fatigue sample with an R ratio of -1 was selected. This design allowed an approximately 0.5inch by 0.5 inch square divot to be introduced, an area about 10x larger than previous efforts. For comparative purposes alloy 4340 was chosen as reference material and C465 and S53 were evaluated. Applied stresses were selected to result in both high strain, under 100,000 cycles to failure and high cycle, over 1,000,000 cycles to failure, total cycles to failure. Runout was set to 20,000,000 cycles.

A4. EXPERIMENTAL METHODS

a. Materials

ESD electrode material and deposition pattern

A cobalt-based wear resistant alloy Stellite 21, AWS ER CoCr-E, was deposited onto the three ultrahigh strength steel alloys using Electrospark deposition process. The chemical composition of the electrode materials and the composition of the three substrate steel alloys, are presented in table 1. Cobalt based Stellite coatings have extensively been used in the industry for corrosion and wear resistant applications mainly due to their high strength, corrosion resistance and hardness. The alloy possesses high resistance to wear and plastic deformation at temperature in excess of 1290°F. Solid solution strengthening of Co based alloys is normally provided by Tungsten, Molybdenum, Chromium and Niobium. Since these elements are all carbide formers, their effectiveness in terms of solid solution strengthening is dependent on the carbon content of the alloy. For each alloy a matched electrode was also used. These electrodes were prepared from substrate material by EDM machining 1.5inch long, 0.125inch diameter electrodes.

ESD was always done with the electrode travel direction and rotation creating a cutting motion. After each pass the electrode was lifted from the surface returned to the opposite side to begin the next pass. The weld progression direction was perpendicular to the pass direction with the ESD torch leading. The tip of the electrode was ground to make a contact angle of 45° with the substrate surface. Figure 1(a) and (b) represent the electrode tip and electrode rotation direction along with weld overlay.

Substrate Materials

Quenched and tempered 300M alloy and precipitation strengthened Carpenter Technology Custom 465 and Ferrium S53 stainless steels were used as substrate materials for ESD and ESD/UIT evaluation. Alloy 4340 was added as a reference alloy for fatigue studies. ESD and ESD/UIT was applied to 4340 using the same ESD treatment conditions as used for C465 and S53. Alloy 300M is a silicon modified 4340 high strength low alloy steel capable of providing higher strength than 4340 alloy along with good toughness. This alloy is generally used after oil quenching and then tempering to provide high tensile strength and good toughness. The alloy is suitable for applications involving heavy sections at moderate temperatures such as aircraft landing gear, airframe parts, fasteners, gears and shafts. In the present work Stellite21 was deposited onto 300M coupon tempered at 400°F or 575°F and after 6 ESD layers, UIT was applied to induce compressive stresses on the coupon surface.

In case of alloy Custom 465, the unusual combination of ultra high strength and corrosion resistance of martensitic stainless steels makes them very attractive in a large variety of applications. The high strength and toughness are obtained by solution treatment at approximately 1800°F followed by aging treatment in a temperature range of 950 – 1000°F. During aging, precipitation hardening takes place in the martensitic phase whereby the final strength is obtained. A variety of different precipitates may form depending on composition and heat treatment.

Ferrium S-53 is also precipitation strengthened by quenching and aging. Its chemistry is significantly different from alloy Custom 465. This alloy was also designed to provide mechanical properties equal to or better than conventional ultrahigh strength steels like 300M with the added benefit of corrosion resistance. The alloy has high hardenability permitting less severe quench conditions for a given section size and resulting in less distortion during heat treatment. The alloy is double tempered at 934°F, then at 900 °F to form complex precipitation strengthening alloy carbides and has excellent thermal resistance at this temperature. Chemical compositions and the heat treatment steps of these alloys used are given in Table 1 & 2 respectively. Alloy 4340 is included since it was used for a reference alloy for fatigue tests. All solution heat treatments and aging treatments were carried out under vacuum conditions by Stack Heat Treatment, a commercial aerospace qualified precision heat treatment organization in Portland, Oregon.

b. Surface Treatment Parameters

ESD: Manual vs. Automated

Previously both ESD and UIT have largely been conducted using a hand held manual operation. Prior research at Portland State University was the first to consider manual ESD and UIT in tandem with the objective to explore the influence of UIT on discontinuities in ESD deposits and on deposition rate when UIT was applied rather than grinding to improve deposit surface smoothness. With increasing ESD layers, the surface roughness increases leading to more discontinuities and reduced deposition rates. UIT increased deposition rates by up to 8 times and reduced porosity. Manual operation of both technologies is dependent on operator skill and experience. Since PSU had limited experience with manual operation of either technology, PSU developed an automated and integrated capability for both ESD and UIT so that reproducible and highly consistent processing could be achieved without relying on manufacturer's representative for experience and expertise. Design and implementation of automated integrated systems under prior research programs enabled the current project to build from prior research. ESD process parameter guidelines for Stellite 21 electrode were provided by ASAP Inc and UIT parameters were evaluated for best results on Stellite 21 deposits.

The ESD equipment in figure 2 consists of two major components; a pulsed capacitor discharge power supply and an applicator head with an electrical ground cable to complete the electrical circuit between the electrode and the substrate. Most of the process parameters are controlled by the power supply, including the voltage, capacitance value, welding current, and pulse frequency. The electrode motion in the applicator head, the wave form shape and width is controlled by the power supply. The electrode is held and controlled by the applicator head with a motor for providing rotational/oscillatory motion to the electrode and a water cooling system for continuous operation. A relative motion between the electrode and substrate is always necessary, either by manual or automated control, to prevent the electrode from welding itself to the substrate. A handheld ESD applicator torch used for manual application is shown in figure 3.

The ESD torch has an inert gas supply system attached to allow a protective cover gas such as argon to flow onto the weld site at all times as in figure 3 and figure 6. The cover gas provides protection from oxidation, cooling and influences deposition characteristics. Argon results in a smoother ESD deposit and reduces oxide formation [1]. There a number of operational parameters involved in ESD process, both mechanical and electrical. Mechanical parameters such as travel motion of electrode on the substrate, rotating velocity, overlap of each pass and electrode contact force against the substrate are important for producing quality deposits. Electrical parameters including spark voltage, capacitance, pulse frequency and duration, pulse current are also important for avoiding heat damage of the substrate. The spark energy or heat dissipated into the system is affected by the spark voltage, current and capacitance. The higher the parameters, the more dense and rough are the coating. Larger capacitance produces a wider pulse width and more heat into the substrate. The ESD process parameters for this research work were established based on extensive research experience design to optimize deposition quality and deposition rates [6-8] These parameters

were chosen for the uniformity and coating density and oxide-free interface between the coating and substrate.

The automated ESD equipment uses a MOTOMAN SV3X robotic system shown in figure 4. The system has 6 degrees of freedom as shown in figure 5 and consists of the robotic arm, the control/programming system and a PushCorp force control unit. The MOTOMAN XRC control system supports the arm and supplies power to the arm and ESD machine. This control system is also the programming interface. The ESD torch is connected to the end of the MOTOMAN arm through a PushCorp pneumatic load control system, figure 4. It is used to control the amount of downward force that the ESD electrode tip applies to the substrate while welding, a critical parameter for quality deposits. Too much force leads to sticking and shorting, too little results in limited pulsed discharges, normally in the 400-800hertz range and resulting minimal deposition.

The ESD electrode diameter for this research was 0.125 inches in diameter and the substrate material was 0.25 inch thick flat coupons, 2 in x 2 in area as shown in figure 6. An optimum set of process parameters for the deposition of Stellite 21 onto the UHSS steel substrates were developed considering the factors affecting the quality of the ESD coating. Table .3 lists the ESD parameters used for all samples.

The ESD process is automated by the use of the Motoman robotic arm which is programmed by a hand held pendant. The programming involved for this research consisted of creating approximately 95 ESD passes that slightly overlap by approximately 10% to create the 1.25 inch square deposit. The 95 passes constitute one ESD layer. The sample was then rotated 90 ° and another layer deposited. An individual discharge splat, an individual pass width due to the motion of the arc back and forth along the 45 degree tip angle, and the multilayer build up deposition layer schematic are shown in figure 7. This entire process is repeated through 6 ESD layers. Then the coupon was treated by UIT. The electrode was always rotated in a direction creating cutting motion and made a fixed contact angle of 45° with the coupon. The electrode tip was ground to a 45° angle to result in the ground angle being parallel to the work piece. The weld progression direction was perpendicular to the pass direction with the electrode leading. Each pass took approximately 5.5 seconds with a travel speed of 0.21 in/ sec. The coupon was initially ground using 240 grit prior to ESD to ensure uniform deposition and the electrode tip was cleaned after every 6 ESD layers. As the electrode angle is ground to match the electrode angle to the workpiece the entire shoulder of the electrode tip is parallel to and nominally in contact with the workpiece. The 400hertz discharge pulse rate results in the arc discharge moving back and forth along the length of the shoulder as the electrode is rotated and moved linearly along the workpiece. The combined motion and arc characteristics results in each splat being partially remelted several times and is an important feature in minimizing deposit discontinuities.

Ultrasonic Impact Treatment

Conventional manual UIT operation consists of manually moving the gun over the area requiring the UIT treatment. The gun must be held so that the impacting pin is perpendicular to the surface being treated. The manually operated UIT system is shown in figure 8. Prior PSU research studying ESD and traditional fillet welds on structural steel that utilized UIT principally employed manual application. Similarly to steps to automate the ESD process in order to ensure consistent reproducible deposits minimizing human skill and expertise, this project utilized a semi automated UIT system, figure 9, designed and implemented under a prior research effort. The UIT gun was fixed vertically downward onto a rigid overhead frame. The default position was retracted vertically by using springs to ensure that the gun assemble would be in the upward retracted position unless air pressure was applied sufficient to overcome the spring upward force and to apply a net downward force to couple the UIT pin to the workpiece. A servo controlled x-y positioner table was configured with a rotary 4 jaw heavy duty rotary chuck that held the coupon for both ESD and UIT. The positioner held the specimen under the robot arm for ESD and then translated the specimen to the UIT applicator for impact treatment. UIT treatment could be applied after every ESD layer, or after as many layers as desired and after the last layer. The Esonix ultrasonic equipment consists of a high frequency generator and a transducer. The system has an operating frequency of 27 kHz and the UIT gun barrel holder is fitted with an ultrasonically coupled tungsten carbide pin to create the working tool. The tool acts as an oscillating indenter plastically deforming the work piece surface with each impact and imparting high level compressive residual stresses. The downward load of the UIT gun was maintained by a pneumatic cylinder and adjustable air pressure adjusted to maintain effective coupling with the part. To treat the surface area, the specimen was moved at a predefined rate under the UIT tool. During the UIT process, the parameters such as the tool diameter, tool tip radius, load, UIT amplitude and intensity, and overlap between UIT passes were kept constant.

In the present work tungsten carbide UIT pin diameters of .125in (3.18mm) and .250 in (6.35mm) were used and comparison was made with hardness measurements and coating quality. Higher travel speeds decrease the amount of time a region is exposed to impact. Larger pins distribute the ultrasonic energy over greater. Since the contact end of each pin was radiused to prevent the pin from gouging the substrate, the contact area was dependent on both the pin diameter and the radius. Based on the actual contact diameter of the pin, for example the 1/4" pin had an end radius to produce a contact diameter of 0.062" as shown in figure 10, the pass overlap was set to 50% for all experiments. The 1/8" carbide pin contact area was 0.056". Both pin diameters were radiused.

Preliminary and final treatment parameters used for UIT and for ESD plus UIT are shown in tables 4 to 6. For Preliminary experiments assessing UIT processing parameters two travel speeds and two UIT intensities were employed, (1) 0.34inch/sec and a UIT intensity level 20 on the Esonix controller and (2) 0.57inch/sec and a UIT intensity level of 28.

Final UIT processing parameters used for treating ESD deposits on each UHSS alloy coupons for detailed HAZ characterization and for fatigue samples treated using UIT employed a 1/8inch diameter carbide pin, travel speed of 0.12 inch/sec, and an intensity level of 14 on the Esonix controller, table 6. For some samples UIT was applied after every 3 ESD layers. In a few cases UIT was applied before ESD. Detailed characterization of the ESD deposit and the HAZ was carried out for ESD only and for integrated ESD+UIT for heat treated 300M, C465 and S53 UHSS

C. Analysis Methods

Optical Metallography

A typical test coupon is shown in figure 11. Coupons were divided into multiple treatment areas, ESD only, ESD+UIT, and UIT+ESD. After ESD and UIT, the specimens were sectioned using a Struers Accutom 50 precision sectioning system. Samples were mounted and prepared using standard metallographic practice. Grinding and polishing to a 0.04 micron finish was carried out using a Struers Rotopol automated polishing system. Optical metallography was carried out using an Olympus PMG3 research microscope. Imaging was done in bright field and using Nomarski conditions both as polished and etched samples were examined. Quantitative image analysis was carried out using a Struers Scentis software package. Microstructures were revealed using immersion etchants for each alloy. Each etchant and etching time are given in table 7.

Electron microscopy

Scanning electron microscopy was conducted using a field emission analytical FEI Inc Sirion SEM operating between 5-20 kV in the secondary electron mode. SEM analysis was used to study the coating and substrate microstructure and chemistry. An FEI dual beam FIB workstation was used to prepare TEM samples. A 200kV analytical FEI Tecnai Transmission electronic microscope was employed for microstructure morphologies and characteristics of heat affected zone, substrate and deposit material.

Microhardness Analysis

The Knoop microhardness scale with a load of 25gmf was utilized to assess the hardness of the deposit and the substrate. The small load was helpful in determining the hardness of the transition region and HAZ which is usually 10-20 μm thick. Hardness readings were taken every 16 μm starting at the interface and progressing into the deposit /substrate forming angled vertical traverses that distinguish between coating and substrate as shown in figure 12. Depending on the thickness of the coating, 4 to 6 readings were taken starting from the interface into the coating. Similarly 6 to 8 readings were taken in the substrate starting from the interface into the base material. A total of 5 such traverses were taken per sample and the 5 measurements at each distance were averaged. Microhardness was done on unetched surfaces with a dwell time of 15 seconds each. Fig .12 shows a vertical traverse of indents on a Custom 465 sample.

Nanoindentation and scratch test analysis

Specimens were analyzed by both CSM and Hysitron Inc for nanoindentation and for scratch testing. A CSM Instruments Nanoindentation Tester with a diamond indenter of Berkovich geometry was used to perform the nanoindentation testing. Nanoindentation matrices were performed in the coating and the substrate to map the surface properties. Figure 13 represents the optical image of the matrix of indents performed on ESD of Stellite 21 on Custom 465 alloy.

A TI 950 Triboindenter™ nanomechanical test instrument was used to perform nanoindentation tests by Hysitron Inc. Figure 14 shows a 60 X 60 μm area with an array of indentation tests on Custom 465 alloy.

Residual Stress Analysis

X-ray determination of residual stresses were carried out by Proto Inc. Depth profiles of the residual stresses were determined by successive electrochemical surface removal and subsequent X-ray measurements. The size of the locally removed area was small compared to the specimen size, so that the resultant redistribution of stresses could be ignored. Profiles depths of 600 μm from the ESD surface. Fourteen combinations of ESD and UIT conditions were evaluated. Table 8 and figure 15 lists the combinations of ESD and UIT test conditions.

Fatigue test coupon preparation

A total of approximately 150 flat tapered constant stress, “Krouse” type fatigue samples were prepared from alloys 4340 and C465. The specimen configuration is shown in figure 16. Blank sections were removed from the as received C465 and 4340 material such that two samples could be prepared from each 0.125inch thick blank, figure 17. Preparation of the samples required a series of dependent steps listed below in order to achieve the desired test coupons in which the ESD and the ESD/UIT processing were carried out on fully hardened geometrically identical samples prepared under identical conditions to minimize any variation in fatigue behavior due to sample variations or sample preparation variations.

- 1) Bandsaw oversized blank from as received soft alloys.
- 2) Machine edges to produce identical X-Y dimensions.
- 3) Rough machine bandsawn surfaces to approximately 0.150 inch thickness.
- 4) Setup CNC mill to locate and drill 6 locating holes (3 per sample) to reference sample location in the fatigue test machine.
- 5) Surface grind to 0.125inch thickness using low stress grinding practices. Surface roughness ranged from Ra 0.6microns to 0.25 microns (between Ra 8-24 in micro inches)
- 6) Vacuum heat treat to fully hardened condition.
- 7) Surface grind divot into each blank such that the two samples will have the divot in the same location in the final sample. Low stress grinding practices with an edge radiused grinding wheel was used to create a divot with radiused edges rather than a sharp 90° divot edge. Divot depth was constant at 0.004inch depth.

- 8) Create an EDM fixture for holding heat treated blanks for EDM machining to slightly oversized, +0.010inch on each side, coupons. The sample locating holes for the test fixture were used for reference points for the EDM setup and for final CNC milling.
- 9) EDM each blank creating two samples per blank with dimensions 0.020inch oversized
- 10) CNC mill the sides of each sample to final dimensions using a carbide end mill and the locating holes as location references
- 11) Use a Dremel hand held tool equipped with a rubber backed abrasive wheel to hand dress the edges of each coupon to remove milling chatter marks. Once the edges were smooth the same tool was used along the edge to surface corner to slightly chamfer each of the 4 surface-edge interfaces.
- 12) For samples treated with ESD or ESD/UIT, samples were sent back to the surface grinding facility to low stress surface grind the filled divot area flush with the sample surface, with a maximum of 0.001inch grind depth into the surface of the sample.
- 13) The final sample thickness was measured for each sample and used for maximum bending stress calculation.
- 14) For baseline and divoted samples treated with ESD/UIT additional UIT treatment was applied to both surfaces in the region where the wide end of the sample entered the fixed end clamp.

The surface condition directly influences S/N fatigue life with polished conditions resulting in the best fatigue life especially for high cycle tests where a significant portion of the total life can be spent initiating the surface crack. It was not considered possible to polish the 6inch long tapered samples used in the program. Even if they were, it is impossible to polish the ESD deposit to the same level. A uniform surface finish practice was used such that all baseline and all portions of the ESD and ESD/UIT treated samples had the same surface grinding procedure. Any deposition defects, porosity or bridging type defects at the surface would remain and likely reduce fatigue life, all other conditions being the same. The surface ground baseline condition used in this project was not necessarily the best that can be obtained in production using advanced grinding practices but it was consistent and considered typical. The dremel hand held polishing step on the edges of the test samples resulted in a smoother surface than on the surfaces.

One of three Fatigue Dynamics fatigue test systems with the tapered sample inserted is shown in figure 18. The system uses a fixed, variable, displacement to produce a maximum bending stress as a function of the displacement. The maximum bending stress on both the top and bottom surfaces is set by fixing the eccentricity of the crank shaft according to the bending stress-deflection equation which is a function of the sample configuration – length, width, taper, modulus, and thickness. The test system has a set maximum load capacity of 200 lbs and a maximum deflection of 2 inches. A maximum desired capability stress range, 200,00psi, was estimated for the low cycle high strain portion of the fatigue curve. The fatigue sample configuration shown in figure 16 was designed to allow maximum fully reversed bending stress levels of 200,000psi. Longer samples would not develop the required stress and shorter samples while requiring less deflection would exceed the 200pound load capacity. These limitations guided the final sample configuration.

Breakage just inside the fixed end grip or just at the point of the fixed end clamp assembly or at the narrow end at the flexing knuckle crank shaft end resulted in a “no data” test. Two steps were taken to mostly eliminate this problem. Examination of the surfaces of the samples that broke just inside the fixed end revealed an oxide scale debris suggesting fretting or rubbing of the sample with the clamp surface, leading to crack initiation. The clamp surfaces were ground smooth and a slight radius added to the leading edge of the clamp at the point where the sample exited the flat clamped fixture. Since the test coupon was about HRC52 and the clamp surface hardness was less than HRC50, the clamp was re-heat treated to about HRC54. Additionally an approximately 0.25inch wide section of the fatigue coupon +/- .125inch on both sides of the coupon from the point where the test coupon entered the clamp on the fixed end was treated using UIT to introduce local compressive residual stresses. The use of both techniques greatly reduced the amount of sample failure outside of the middle portion of the fatigue coupon from about 60% to 25%. This again demonstrated the beneficial effect of UIT on fatigue at points of stress concentration.

An issue developed with the ESD deposition that was not realized until midway through the testing program by the graduate student applying the ESD and running the fatigue tests. Even though the divot was filled by ESD as measured by calipers, that measurement measures the peak height of the ESD deposit and not the minimum valley depth. As ESD layers are deposited the surface becomes rough and subsequent Arc discharges tend to discharge to the highest points, making them higher. Proper practice would be to smooth these peaks after perhaps 4-6 layers to minimize this effect. Since only 8 layers were typically applied the graduate student did not smooth an intermediate layer of the deposit, resulting in peaks that were measured by the calipers, not valleys. This implication was not apparent until the final surface grind to smooth the deposit to the overall sample thickness. At this point valleys still existed. A number of these samples were tested in this condition. Later, any samples with an incomplete ESD or ESD/UIT fill after surface grinding, had the valleys retreated using manually applied ESD and then UIT post processed, then resurface ground to result in a much better final surface finish in the divot repaired region.

A5. RESULTS

Due to the amount of results for three alloys, two of which were evaluated in 2 temper or aged conditions, for a total of 5 alloy conditions, the results section focuses on Custom 465. Similar results were obtained for each alloy. Detailed comparative results for S53 and 300M are presented in the Appendix. The ESD deposit and deposition and the UIT parameters were the same for each alloy.

a. Ultrahigh strength steel alloys tensile properties

The tensile properties including Young's modulus and Poisson's ratio determined by using dual axial and transverse extensometers are shown in table 9. The tempering or aging temperature for each alloy is shown with the alloy. All test coupons used for ESD and UIT characterization were heat treated to these fully hardened commercially representative strength levels, unless otherwise noted. A few 300M test coupons were treated by ESD and then lightly etched for preliminary evaluation of the width of the HAZ as observed by nital etching, since the low alloy steel is very sensitive to etching even after low levels of tempering.

b. Electrospark Deposition:

Initially efforts were directed at ESD electrodes made from the respective substrate material, 300M onto 300M and C465 onto C465. It was not possible to deposit a uniform high quality ESD deposit. The Martensitic phase transformation and very high hardness of the as quenched 300M alloy resulted in extensive spalling and delamination. Results on 300M alloy showed that the full width HAZ was developed even if no coating was deposited. The ESD arc strikes onto the substrate resulted in a HAZ width just as if a deposit were achieved. Since if a deposit layer had been achieved, a second layer would have been slightly further from the substrate, the overall width of the HAZ is governed by the initial pass. Subsequent deposit layers progressively smaller regions of the initial HAZ. A Stellite 21 electrode was selected for all remaining efforts and is the ESD deposit material for all ESD and ESD+UIT characterization activities.

Optical micrographs of matching substrate and deposit ESD and of the Stellite 21 ESD cross sections are shown in figure 19 and 20. The tremendously improved nature of the ESD deposit obtained using Stellite 21, a cobalt based austenitic alloy is clear. The HAZ in the 300M is visible and on the order of 20 microns wide. No HAZ is discernible at this low magnification in the C465 alloy aged at 950°F for 4hrs. These images are representative of all cross section optical metallographic results deposited on each UHSS alloy. The ESD processing parameters and programmed electrode motion which together form an ESD deposition procedure resulted in high quality reproducible deposits.

c. Microstructural and microchemical analysis:

Due to the fine structures in the fully heat treated UHSS alloys, Optical metallography can only provide overall cross section perspectives of major features such as HAZ width, and

coating integrity and quality and thickness. High Resolution field emission SEM in secondary and backscattered modes provides a more detailed image and chemistry analysis capability. Figures 21 to 23 illustrate SEM images of ESD cross-sections for alloy Custom465 aged at 950°F. A cross section SEM view of C465, etched to reveal the ESD structure, the HAZ and an overetched substrate is shown in Figure 21. SEM imaging of lightly etched C465, Figure 22, taken at 1,000x magnification shows the martensitic lath structure more clearly than does optical metallography. Careful examination of the apparent HAZ in figure 21 shows that approximately ½ of the initially appearing HAZ zone, about 20 microns wide, is actually ESD deposit and that the substrate HAZ is only about 10microns wide. The difference in SEM image contrast is the result of dilution of the substrate into the first deposit layer as in a typical weld dilution.

To study the amount and extent of substrate dilution into the ESD energy dispersive x-ray analysis, using point spectrums, and line scans were carried out. Typical results are shown in figure 23. The fine grain structure in the coating is aligned normal to the substrate and dilution layer interface. The base microstructure of aged C465 shows martensite laths of different orientations with in a prior austenite grain as shown in figures 24-25. Energy dispersive X-ray analysis (EDX) along the coating –substrate reveals the change in chemical profile along the transition region. Line scans in the ESD deposit reveal dilution layer of 5-12µm, but the actual thickness might be less than 12µm, as suggested in the TEM cross section image in figure 63. The effective volume contributing to elemental analysis in the SEM/EDS limits elemental spatial resolution. A tabular analysis of SEM/EDS point spectrum analyses is shown in table 10. Also included in the table are EDS compositional analyses for the Stellite 21 alloy and for the substrate C465. The compositional transition from the ESD to the substrate resulting from dilution of the discharge splat with the prior layer is about 12 microns wide. This is achieved in about 3 layers of ESD. After 3 ESD layers the ESD chemistry is that of the electrode material without any further dilution. Due to the major chemical difference between the Stellite 21 ESD electrode and the steel alloys, this dilution zone represents major chemical gradients in elements such as Co, Fe, and Ti for 300M and C465.

The transmission electron micrograph as shown in figure 26 was obtained from Custom 465, a ferritic stainless steel, aged at 950°F for 4hrs; the corresponding microstructure was composed basically of lath martensite with a high density of fine precipitates shown in the bright and dark field images of figures 26 and 27. Figure 26 also shows the corresponding selected area diffraction pattern (SADP) obtained from the specimen aged at 950°F for 4hrs without any ESD or UIT treatment. The intense ferritic bcc matrix spots are indexed. The less intense precipitate reflections are arranged in streaks and spots generated by rod shaped precipitates on 3 habit planes visible in the dark field image in figure 27. There are also some equiaxed precipitates present in the dark field image. The matrix lath, rod shaped and equiaxed precipitates visible in the bright field image produced the corresponding diffraction pattern in figure 26 and the precipitates were identified from measured d-spacings as intermetallic hexagonal “omega” Ni₃(Mo,Ti) phase or bcc “chi” Cr₆Fe₁₈Mo₅ phase. It should be noted that Ni₃(Mo,Ti) tend to precipitate in austenitic stainless steel or high nickel alloys as cubic gamma’ or hexagonal “eta”

whereas bcc “chi” tends to precipitate in ferritic steels such as C465. Figure 27 shows the same SAD pattern as in figure 36 with arrow marking the intensities used to generate the dark field image.

In the case of ESD and UIT treated specimens, due to the variation of temperature with depth in the heat affected zone, a diverse microstructure formed in and near the HAZ-substrate interface and in the substrate region away from the ESD treated area as shown in figure 28-30. In figure 30 there was no evidence of precipitates in the HAZ and nearby substrate, contrary to the presence of very fine precipitates and twinned laths in both ESD treated and ESD+UIT substrates. However precipitation did occur in the mixing zone. Similar observations were found in Custom 465 alloy aged at 1000°F, except in the ESD and ESD+UIT treated specimens there was no evidence for the presence of precipitates in the HAZ. The UIT treated Custom 465 alloy aged at 950°F FIB TEM sections at 1mm and 6mm below the UIT treated surface revealed in the 1mm deep section micro twins in highly stressed fine lath martensite (grains 0.1µm wide) with a clear boundary between the highly stressed thin grains and the undamaged remainder of the substrate microns below 1mm. See figures 31-32. Figure 33 shows the C465 microstructure at 6mm below the UIT surface. Figures 34 and 35 are dark field images of the fine precipitates and some larger ones at this depth. To characterize the degree of mixing of the C465 with the ESD coating a backscatter image was generated from a FIB TEM thin section of the substrate, the HAZ and the mixing zone. See appendix figure I-100. The white high average atomic number Co Cr rich Stellite coating is on the left and the dark low average atomic number martensite lath of the C465 substrate heat treated at 1000°F is on the right.

A low magnification bright field TEM image of the Stellite coating, the mixing zone, the HAZ and the substrate is visible in the appendix, figure I-94. A TEM micrograph of the C465 substrate without any UIT treatment, aged at 1000°F, shows the same precipitates, only larger than in C465 aged at 950°F, appendix figures I-91 through I-93. Ferrium S-53 and 300M are also presented in appendix-I. Due to 0.2 wt % and 0.45 wt % carbon in Ferrium S-53 and 300M alloys respectively, carbide precipitates were expected in these alloys. TEM micrographs of Ferrium S-53 reveal the presence of M₂C precipitates along the grain boundaries. Alloy 300M was tempered at 400°F or 575°F for 2hrs, during this tempering treatment precipitation of M₂C carbides occurs and were shown in the SEM and TEM micrographs in figures I-115-117 and figures I-132-135. A significant number of voids were present in Stellite 21 coating deposited on 300M alloy. The absence of voids in the other two alloys indicates the possibility of hydrogen diffusion from the 300M substrate into the Stellite deposit. TEM micrograph of UIT treated 300M alloy taken at 1mm from UIT surface showed finer laths than that taken at 6mm from UIT surface. There was an indication of twins in both samples.

d. Microhardness profiles

Averaged microhardness profiles were established with each indent value reported representing an average of 5 measurements at the same relative depth position. Alloys 300M tempered at 400°F, C465 solution treated and aged at 950°F and at 1000°F, and S53 solution

treated and double tempered at 934°F and 900°F were surface treated by ESD using Stellite 21. In some cases the ESD was followed by UIT. For each condition averaged microhardness profiles from the ESD-substrate interface into the ESD and into the HAZ were generated. Figure 24, an optical cross-section image of Stellite 21 deposited on custom 465 alloy with and without application of UIT treatment, is typical of ESD substrate cross sections. A hardness depth profile, figure 25, analyzed by averaging 5 microhardness profiles for indent position is a typical microhardness profile. The Struers automated Duramin microhardness test system enable 5 identical computer generated test location profiles to be generated for each sample and identical profiles for each cross section analyzed. Figure 37 shows the knoop microhardness, (25gram load) profile for ESD of Stellite 21 Carpenter Custom 465 aged at 950°F. Results have been displayed adjacent to actual microhardness indents on sample cross sections to show the relationship between microstructure and hardness. The hardness drop in the HAZ is a maximum near the substrate interface and rapidly increases to the bulk substrate level. Similarly the ESD deposit adjacent to the ESD substrate interface is reduced in hardness relative to the ESD deposit further from the interface. In the HAZ the portion closest to the interface is subjected to the highest number of short duration thermal pulses generated during the deposition of the first several ESD layers after which additional layers do not result in sufficiently high HAZ temperature spikes to influence the C465 alloy. The cumulative effect of these thermal pulses is to soften the age hardened C465 in a very narrow HAZ zone. Similar result profiles for alloys heat treated S53, 300M, and for Custom 465 aged at 1000°F are included in appendix I. A hardness only plot of the hardness profile from the ESD, across the substrate interface and HAZ, and into the base C465, figure 37, shows a base C465 microhardness value, about 650Hv, the as deposited Stellite 21, 700Hv, slightly harder than the C465, but an excellent match as deposited, and the narrow HAZ softened zone hardness reduced to nearly 400Hv. The influence of UIT after ESD and on UIT followed by ESD onto Custom 465 UIT on the measure hardness is shown figures 37-39. The clear influence of UIT on the microhardness is evident on each region of interest, ESD, Interface, HAZ, and substrate. The Stellite 21 hardness was raised from 700Hv to 850Hv, the interface minimum from just above 400Hv to nearly 500Hv and the C465 substrate adjacent to the HAZ, to 700Hv, an HRC equivalent value of hardness is 58-60HRC. Applying UIT prior to ESD had a small influence on the C465 microhardness and the ESD deposit, as expected, had the same hardness as the sample with only ESD.

A comparative analysis of the influence of UIT pin diameter on the hardness-depth profile for C465 alloy after UIT treatment using either 1/4" or 1/8" diameter pins is presented in figures 40-41, first on just the C465 base metal and then onto ESD treated C465. The larger pin size resulted in increased hardness while the smaller pin did not result in a significant increase in hardness. The increased microhardness for the first 50 microns in depth was likely due to residual effects of the machining and surface grinding operations used to make the test coupon. Analysis of the effect of pin size on microhardness values for ESD deposited Stellite 21 and for the substrate C465 revealed that the larger pin size resulted in a significantly larger increase in

the as deposited austenitic Cobalt based Stellite 21 hardness but made no difference in the martensitic age hardened C465.

A second UIT variable, the intensity level as set by the UIT controller, was evaluated relative to its influence on the microhardness profile. There was no evidence, figure 42, that doubling the intensity level influenced the microhardness of either the Stellite 21 or the C465 substrate. A more detailed investigation of intensity effects was not pursued in order to limit the number of variables in this project. There may be a critical intensity level which when exceeded does not result in further increases in hardness. Developing a more detailed understanding of the influence of UIT parameters this was beyond the scope of this effort.

A third UIT process variable, travel speed of the pin was evaluated, keeping UIT pass overlap constant. Its effect on the profile hardness is shown in figure 43.

From these results it is clear that there is a critical total UIT input energy level resulting from travel speed, for a set intensity level and pin contact area. The number of impacts rather than the intensity levels considered of each impact, governed the increase in hardness in the ESD deposit, HAZ and near HAZ microstructure.

e. Nano indentation

In order to achieve finer resolution than possible with microhardness indentation, nano indentation tests were carried out on C465 aged at 950°F for Portland State University by CSM Instruments and by Hysitron. An array of indents, figure 45, was produced and the hardness and reduced modulus determined. Color coded maps of hardness and modulus show the hardness variation in each region, figure 45c. Consistent with microhardness results, the width of the HAZ as measured by hardness changes was about 20microns. Unlike the hardness data, the modulus results showed no systematic variation from the substrate to the ESD deposit in figure 45d. Plotting these hardness data in graphical format, figure 46, confirmed the color coded representation. Similar plotting of the modulus, figure 47, however better illustrated a slight drop in modulus in the HAZ zone, not evident in the color coded representation.

f. Residual stress profiles

Residual stresses were measured as a function of depth from the top surface by Proto Inc using X-ray analysis with chemical depth profiling. PSU sent Proto a portfolio of samples of both 300M and C465 that included the following conditions for residual stress depth profiling. Two inch square by 1/4inch thick coupons containing base metal, UIT only at 2 intensity levels, ESD only, and ESD&UIT at 2 intensity levels. Coupons were prepared consistent with other test coupons used for metallographic, microhardness and microscopy. The UIT processing parameters evaluated and surface residual stress results for each test condition are shown in Table 11 for both quench and tempered 300M and C465 aged at 950°F. The as prepared surfaces of both alloys exhibited a slight compressive stress state. Both received a light surface grinding, 240 grit prior to ESD or UIT to remove any minor surface oxidation that might influence the ESD deposition. The electrospark deposition process always results in a significant tensile

residual stress, 60-80ksi due to the nature of the large substrate mass and small volume molten ESD splats. Application of UIT directly onto the substrate resulted in significant compressive stresses, -135ksi and -185ksi respectively for 300M and C465. UIT onto ESD deposited Stellite 21 alloy on both alloys resulted in very high levels of surface compressive residual stresses. Only single residual stress values, rather than statistically sampled values were obtained for each test condition.

Residual stress depth profiling by Proto used chemical milling to electrochemically mill. This process was stopped at successive depths in 0.005inch increments and the residual stress level determined. Since the ESD deposit was less than 0.010inch thick the residual stress profiles included the ESD HAZ region and beyond in depth. Residual stress depth profile results were consistent for 300M and for C465. Typical results for C465 aged at 950°F are shown in figure 48. The as machined, vacuum heat treated and lightly ground coupons all showed low levels of residual stresses. The ESD deposits all resulted in high tensile residual stresses up to +100ksi in the deposit with little residual stress influence in the substrate. UIT treatment resulted in high level of compressive residual stress in the ESD and in the substrate. Figure 48 demonstrated that the UIT treatment produces high level, on the order of -150ksi with or without the ESD. In all cases this compressive residual stress extended past the 0.020inch (500micron) depth of residual stress measurement in the 0.250inch thick coupons. Increasing the residual depth profile depth showed that the compressive stress field extended to at least 0.060inch.

g. Fatigue Behavior

S/N total fatigue life curves for all material test conditions including the reference alloy 4340, and Custom 465 aged at both 950°F and 1000°F are shown in figures 49-60. Mathematically derived curve fitting attempts were unable to reflect the data. Manually drawn trend lines were constructed using a segmented dual linear line construction. Separating the data for any test condition into multiple segments resulted in improve polynomial curve fits for each segment but required some data to be used in both data sets. No multiple segment data analysis routine was able to reflect a “knee” in the data. Analysis with and without the manual trend lines and with only the trend lines are included as are comparisons between alloy results and between baseline and ESD and ESD/UIT processing. Run out test data points, more than 20,000,000 cycles, serve as a lower bound endurance limit. Examination of the baseline and ESD/UIT data indicate a high strain low cycle region and a high cycle lower stress region, each with its own slope. In the baseline and especially for the ESD/UIT treated conditions there was only a slight decrease in maximum applied stress in transitioning from low cycle to high cycle run out behavior. That is the slope of the high cycle portion was slight and it was difficult to obtain fatigue lives in the 1,000,000 to 20,000,000 life range. A significant number of Custom465 test samples failed at or in the fixed clamped end when tested in the “knee” or transition range from low cycle to high cycle. These data points are included in the figures, but are circled and not included to construct the trend line. Under runout conditions obviously there were no failures in the clamped region. Nor were there fixed end clamp failures for the high stress low cycle portion

of the curve. In order to try to minimize failures in or at the clamped end, both sides of the test coupon were treated with UIT. This helped minimize clamp end failures, except in the transition region from high stress to high cycle fatigue.

There was evidence of debris and some oxidation on the clamped end of some samples suggesting fretting damage. The test results support a critical stress/sample deflection level in which fretting damage could result in fatigue cracks and failure. This would result in a competitive failure location. Under high stress low cycle failure conditions, there may not have been sufficient cycles to initiate fatigue cracks due to fretting leading to failure in the more highly stressed tapered width constant stress section of the sample. As the applied stress decreased to the transition region which was nearly equal to the runout stress/deflection level for the sample, fretting still developed in the clamped fixed end portion leading to failure in the clamped portion. As the stress was reduced to levels lower than the runout stress level, fretting threshold conditions were also not achieved. Despite the incidence of failure in the clamped end for a narrow stress range, the results provide clear trends and comparisons between the 4340 and Custom 465 and between the two Custom 465 aging conditions. Similarly the influence of the high tensile residual stress level in as deposited ESD was consistent independent of alloy and consistent with prior fatigue results. The influence of ultrasonic impact treatment was also consistent with its well known ability to improve fatigue behavior of weldments. The high level of compressive surface and near surface compressive stresses substantially improves the fatigue behavior of ESD. In the high stress/low cycle regime the behavior approaches that of the baseline behavior.

In the high cycle/lower stress portion of the fatigue curve the integration of UIT into the ESD process procedure resulted in a clear endurance limit. No endurance limit was established for ESD only conditions, except for perhaps 4340. A test run at a maximum 40ksi stress level reach runout conditions, suggesting an endurance limit of between 40ksi and 50ksi. Tests on ESD only conditions on custom 465 were not run below 60ksi maximum stress.

The influence of an incompletely filled divot on fatigue behavior was not a design variable. The factors that led to this test condition were the result of the hardness levels of the ESD, the robotic deposition vs manual deposition, and graduate student learning experience. Hindsight analysis would lead to a modified automated integrated ESD and UIT deposition process to avoid this condition. A modified procedure was implemented on select 4340 ESD/UIT test samples such that the surface filled divot conditions were substantially improved. These results are shown in figures 49-50. These data and a modified trend line are marked with a star. The improvement was dramatic and the high cycle fatigue behavior is nearly identical to the baseline properties. Overall the results showed that the aging temperature and hence strength and toughness of C465 influenced the high cycle fatigue – endurance limit properties.

Optical imaging of the fracture surfaces of select samples as well as top down views are shown in figures 65-80. The application of UIT to the fixture end of the sample, where it enters the fixed clamp end of the test system, is shown in figure 65. UIT treatment significantly reduced failures in and near the clamped end. Cross sections of 4340 baseline tested samples revealed

cracking starting from a corner and propagating through the fine grained microstructure. The more coarse grained microstructure of C4645 clearly revealed in optical and SEM metallographic analysis of cross sectioned samples, is also evident in the fracture surface of C465 samples, figure 73,76. The material was laboratory forged to approximately a 3.6inch by 3.6inch cross section from an initial 8inch diameter round section. Examples of incomplete ESD fill revealed after surface grinding are shown in figures 65-70,74. An example of one of relatively few completely ESD filled divot is shown in figure 77. About 20-30% of the ESD/UIT treated samples tested at low cycles to failure test conditions failed outside of the ESD/UIT treated area and were thus equivalent to or better than the base material

The Fatigue crack or cracks always initiated in the ESD filled divot for all samples treated with only ESD. Fatigue cracks in the ESD/UIT integrated fatigue samples for the most part initiated within the divot filled area. Several however, tested in the low cycle fatigue live region, failed in the base materials away from the ESD/UIT treated divot. In one case while the ESD/UIT divot area exhibited many surface cracks, figure 72, the main crack path resulting in failure occurred in the base material and not in the ESD treated region, figure 71. This is consistent with the overall observation that the ESD fill followed by UIT exhibited high strain, low cycle fatigue life behavior nearly identical with the base material. For high cycle test conditions where significant life is spent initiating a crack the ESD/UIT treated samples demonstrated a reduced runout stress, likely due to surface defects resulting from an incompletely filled ESD divot. As the total cycle life becomes larger more cycles are required to initiate fatigue damage induced cracks in a smooth surface. The incompletely filled divots served to dramatically shorten the cycles to initiate a crack relative to a smooth surface.

A summary, table 12, expresses the fatigue life at three fatigue life regions in terms of the percentage life cycles relative to the base metal. This tabular summary clearly shows the importance of proper ESD fill of the divot and the essential role of UIT treatment.

A6. DISCUSSION

This discussion will concentrate on the major results relative to ESD, integrated ESD and UIT, and fatigue properties as applied to ultrahigh strength alloys, both conventional and new generation with enhanced corrosion resistance. First, relative to the basic electrospark deposition process, its application to these quench and tempered or aged ultrahigh strength steels requires using an austenitic electrode that does not undergo a matrix phase transformation during quenching, that is not sensitive to repeated tempering cycles representative of a multi splat, multi pass, multilayer ESD deposit and yet can develop a high as ESD deposited hardness. An In718 electrode works well but in the as deposited condition achieves a HRC38 hardness and even with UIT applied is limited to about HRC50 hardness levels. Stellite 21 is also a suitable alloy that meets deposition requirements. It responds well to ultrasonic impact treatments. Its hardness ranges from HRC 52 in the as deposited condition to HRC60 after UIT treatment.

Optimizing the ESD process for “heat input” sensitive alloys, that are not welded in the heat treated condition and that require post weld heat treatment, requires processing parameters that take advantage of the low heat input on both a per splat deposit and per pass deposition. This requires the electrode to move in a manner that allows the HAZ zone developed as the electrode discharges at any position to reach a maximum acceptable “interpass” temperature, using a welding analogy. If the electrode continues to discharge in too small of an area the HAZ, the interpass temperature between splats will gradually increase and its effect on the microstructure in the substrate HAZ will become more pronounced. This research effort used a robotic system and the rotating electrode’s travel pattern resulted in a 7-8 second interval before the electrode made an adjacent pass on the same layer. The deposit area was approximately 1inch by 1inch. Had the deposit area been much smaller the program could be changed to result in a constant interval between passes by increasing the pause time at the start of each pass. Usually changing the ESD deposition parameters results in changes in the ESD deposit itself, resulting in interpass time as the best modifiable variable. This can also be done using a manual ESD as long as these conditions are integrated into the ESD procedure. The robotic and ESD deposition parameters used for this project resulted in heat affected zones less than 20 microns in width, about one prior austenite grain diameter for 300M and less than 15% of grain diameter for the coarse grained C465 and S53 material used in this study. The more temper resistant the alloy, the narrower is the resulting HAZ. Even though the both the C465 and S53 require aging temperatures of 900-1000°F and aging times of several hours to develop their working hardness, the ESD process results in a narrow softened HAZ with negligible cumulative time at and above these temperatures. The peak temperature however at the deposit-substrate interface is at least the solvus temperature of the substrate as demonstrated by dilution of the substrate into the ESD deposit. The width of the HAZ is then largely determined by the first one or two passes with a set of ESD parameters in concert with the thermal response of the substrate. This suggests that it may be possible to adjust the deposition parameters, perhaps decreasing the ESD voltage or pulse rate, for the first two layers to reduce the effective heat input into the substrate, further reducing the resulting HAZ, and to then optimize the ESD deposition parameters to maximize deposition rate for the remainder of the deposit. In a similar manner it is possible to envision an optimized functionally graded deposit that takes into account the substrate chemistry to optimize the resulting deposit dilution that occurs over 3-4 ESD layers, and to also optimize the near top ESD layers to maximize corrosion resistance, galling resistance, coefficient of friction, surface electrical properties for the intended application by changing the electrode and shielding gas.

One of the major focus areas of the project was studying the ESD induced heat affected zone in ultrahigh strength steel alloys. Alloy 4340 a conventional Q&T alloy is very heat sensitive with little temper resistance. Both C465 and S53 require aging above 900°F for several hours and the fundamental strengthening precipitates are completely different for each alloy as are the tempering precipitation kinetics relative to 300M. TEM results of each alloy confirmed the precipitates, size and structure in the base material. These base structures were compared to the HAZ microstructure and samples treated only with UIT. UIT alone did not change the nature

of the precipitates in any of the alloys. ESD on the other hand completely eliminated observable precipitates in the ESD induced HAZ for each alloy. The peak temperature in the ESD substrate is its melting temperature. At 10-20microns from the initial surface the peak temperature is sufficient to dissolve the precipitates and results in development of the HAZ width, approximately 10-20 microns, less for C465 and more for 300M. Subsequent passes and layers result in a reduced peak temperature relative to the initial pass depth from the surface peak temperature. As the passes become further removed from any point, whether in the plane of the point or above as passes and layer progress, the reheating peak temperature continues to decrease at any point of reference. The cumulative peak temperature- time at aging temperature for precipitation is insufficient to “re-age” harden the HAZ, at least with observable precipitates. The total HAZ width is still the width of a single grain in fine grain size steel. Based on alloy 300M, containing 1.6Wt % Si, results the ESD reheating cycle from cumulative passes and layers does not result in any carbide precipitation much less any embrittling grain boundary carbide films.

Due to the nature of the ESD process, small liquid droplets are rapidly transferred to a large cool mass, high level tensile residual stresses develop in the deposit. In depositing a hard facing type wear resistant alloy, these coatings have a tendency to microcrack due to shrinkage and quenching induced stresses whether deposited by ESD or by other techniques. These are expected and do not limit performance. In the current case the cobalt alloy does not stress relieve by microcracking during solidification or cooling. X-ray residual stress depth profiles done by Proto Manufacturing Inc demonstrated that high levels of residual stresses are retained and accommodated within the deposit/substrate resulting in tensile residual stress levels approaching +100ksi within the ESD deposit and while decreasing magnitude, extend about 25micron into the HAZ, see figure 48. Fatigue results for as deposited ESD demonstrate a major debit with very low expected endurance limits. This behavior would restrict this process from fatigue limited applications. Current results are consistent with research results on a range of alloy types, Fe, Ti, Ni base. Applying UIT before ESD reduces the amount of subsequent ESD induced HAZ softening and potentially offers the ability to customize the HAZ by integrating deformation and rapid thermal processing leading to the formation of nanograin ultrahigh hardness structures in the HAZ

Ultrasonic impact treatment used in conjunction with ESD on In718 and other alloys has been previously demonstrated to improve the quality and deposition rate of the ESD deposit, increasing deposition rate by up to 8-10 times when applied on interpass layers. The positive influence is due to the fact that the ultrasonic impacts smooth the surface more effectively and do not remove material as do standard sanding practices. Additionally the primary purpose for ultrasonic impact treatment is to induce high level of compressive residual stresses and to do so at greater depths than can be achieved by shot peening. Residual stress depth profiling of UIT treated ESD deposits consistently demonstrated high levels of compressive stresses, up to 240ksi on UIT treated only C465 and 300M at depths exceeding 0.020inches, (500microns). This is well

beyond the combined depth of the ESD deposit and its heat affected zone. Results of applying UIT prior to ESD demonstrated that while the ESD still exhibited tensile residual stresses as expected, that the substrate compressive stresses due to the UIT were still present.

The selection of the tapered flex bending fatigue sample offered several advantages over round rotating or axial type samples. These included a large surface area treated area to be assessed, avoided treated area edge effects, enabled high amplitude fully reversed stress cycles to be readily achieved, (20,000,000 cycles designated as runout). The flat geometry allowed identical ESD and UIT parameters as those used on flat coupons similar to the flat coupons to study base microstructure, residual stress, and microhardness analyses after ESD and ESD/UIT treatments. It also facilitated the application of ultrasonic impact treatment. Lastly there were three test systems available. Each operated at 51 hertz which allowed significant tests to be carried out. Round sample geometry configurations had several drawbacks. Nevertheless the flat tapered fully reversed geometry also presented significant problems to be overcome. The Fatigue Dynamics test system fixturing design and basic deflection based stress generation also presented complications relative to clamping and fatigue failure at the edge of the fixed clamp assembly. In order to generate the required levels of high levels of applied stress the sample was deflected up to +/- 0.9inches for a total of up to 1.8inches. A significant number of samples failed in or at the fixed clamped end and were not valid tests. In two cases, C465 aged at 950°F baseline, (no ESD or UIT), and for samples aged at 1000°F baseline conditions, end clamp fatigue failures are shown in the S/N curves. These data points are circled and were not considered in the trendlines. The number of failures at or in the clamped end was reduced by the application of UIT on both sides of the sample at the entrance position of the sample into the fixed clamp end. This reduced but did not totally eliminate the problem.

In at least one ESD/UIT treated sample fatigue crack failure initiated and propagated across the sample outside the ESD/UIT treated area, even though the ESD/UIT area itself was cracked. This supports the S/N curves results showing that in some cases the ESD filled divot treated by UIT had fatigue behavior equivalent to the baseline condition. As is well known the surface finish influences fatigue life S/N behavior. For these tests all samples were surface ground under the same grinding conditions so that the baseline behavior is specifically for the as ground surface condition. All grinding was done parallel to the length of the sample.

A significant problem involving ESD divot filling created unexpected but informative set of data. Fatigue results clearly demonstrate the significant benefit of UIT treatment on ESD deposits, even when the ESD deposit does not completely fill the divot, leaving underfilled areas. A more optimum ESD/UIT treatment resulting in completely or nearly completely filled divots and significantly improved fatigue behavior under high cycle fatigue conditions for alloy 4340, resulting in a separate S/N curve for properly filled divots as compared to underfilled non optimum treated filled 4340 divots. Optimum treatment resulted in S/N curves approaching that of the baseline data in the surface ground finished condition. While similar data for underfilled

and optimally filled ESD was not generated for C465 it is expected that similar results would result and would raise the endurance limit more nearly to base level conditions.

The underfilled divot condition was the result of a measurement error. The ESD process creates a surface with peaks and valleys. The estimated number of layers to fill the divot was based on preliminary caliper measurements which measured the peak height not the valley depth. All the samples were prepared before sending outside to a surface grinding facility. After being returned tests were initiated and the operator did not report that grinding flush with the original surface revealed that the ESD valleys were not removed. These test data for alloy 4340 are reported as ESD or ESD/UIT marked with a star. Once the problem was identified, further tests were delayed until the samples were treated again by manually applying ESD to the valleys, then reapplying UIT, surface grinding again, then testing.

Despite the incompletely filled divots, the combination of ESD and UIT treatments was nearly equivalent to base metal S/N behavior for the higher strain levels, up to about 1,000,000 cycles to failure. High cycle fatigue test conditions including runout, 20,000,000, cycles were reduce relative the base metal, although this degradation is likely partially due to the relatively poor ESD fill. Adding a second manual ESD to the under filled initial ESD deposit followed by subsequent UIT again, increased the high cycle behavior of 4340 to 95% of the baseline 4340. It is believed that optimally filled ESD +UIT processing of C465 would have also increased high cycle behavior to or nearly to that of the baseline S/N behavior.

Several C465 samples were retreated similar to the retreated alloy 4340 samples and then tested in the applied stress level to better determine high cycle behavior. Unfortunately all these samples broke at the clamped end and not in the ESD/UIT divot area. These test data points have been circled in the S/N figures for C465. They were not included in the trend line but are included to illustrate one of the problems encountered with this sample type. It was difficult to obtain total cycles to failure within the 1M to 20M range. The low cycle to failure, high stress/strain portion of the S/N curve showed that the ESD/UIT performed nearly as well as the baseline materials and that as the failure mechanism likely shifted to stress controlled rather than strain controlled, that the UIT application to the ESD resulted in large improvements to the endurance limit.

Overall, as processed in this effort, the ESD deposition resulted in an underfilled divot and, a poor surface condition accelerating fatigue crack initiation under high cycle conditions. UIT nevertheless resulted in major fatigue improvement. Improved ESD deposition, likely with manual touch up in underfilled areas, should improve fatigue crack initiation resistance, but the high level of tensile residual stresses raises the combined surfaces stress level, (residual plus applied), even for the low applied stress (high cycle regime) portion of the S/N curve, essentially shifting the failure cycles to the left, to lower cycles to failure as if the applied stress in the absence of residual additive stresses were much higher. The UIT induced compressive stresses act to reduce the combined applied and residual stress level, extending the life for stress controlled fatigue cracking, significantly offsetting the underfilled surface condition. For

improved ESD filled divots, 4340 data, treated with UIT, the S/N curve approached that of the baseline material and becomes a better indicator of the potential for integrated and optimized ESD/UIT.

Further optimization of the automated robotic deposition procedure to avoid incomplete fill would likely require UIT treatment on interlayers, perhaps every three layers, to ensure a smooth surface as the deposit thickness was increased and increased “overfilling” as measured by ESD peak heights measured in the as deposited. The high hardness of the as deposited Stellite 21 resulted in the UIT flattening the peaks but insufficiently to fill all the valleys. A different electrode material, for a different end use purpose, for example In625 for corrosion resistance, would have much lower hardness and would deform significantly more than the Stellite 21 electrode, resulting in enhanced fill of ESD deposit valleys. This further suggests that each ESD/UIT procedure needs to be optimized for each application and application of generic procedures may result in variable final properties. Essentially an ESDPS (electrospark deposition procedure specification) much like a WPS (welding procedure specification) should be developed based on procedure qualification tests.

A7. CONCLUSIONS

- ESD introduces high level tensile residual stresses in the as- deposited condition.
- ESD deposit dilution with the substrate occurs in the first 5-12 μm and results in a chemical gradient that influences the hardness of Stellite 21 in the 1st and 2nd ESD layers.
- ESD, if optimized for the HAZ generally results in a narrow heat affected zone less than 10-12 μm wide in ferritic steel alloys and ultrafine grains can develop in the resulting HAZ microstructure due to the nature of the ESD thermal history.
- UIT on heat treated substrate results in heat affected zones with distorted structures with highly stressed grains and twins.
- The heat affected zone formed due to the ESD process eliminates all precipitates resulting from prior heat treatments, resulting in a precipitate free HAZ on the order of a single grain diameter in fine grained materials
- Integrated ESD and UIT application improves the Stellite 21 deposit quality and hardness
- UIT after ESD treatment changes the residual stresses in the coupon from tensile to high level compressive, on the order of the compressive yield stress at depths in excess of 0.020inches.
- Applications that are fatigue limited require UIT treatment to offset major fatigue debits in as deposited ESD. Low cycle fatigue behavior approaches that of the base alloy. High cycle fatigue properties are also significantly enhanced by UIT and are also influenced by the quality of the ESD deposit, including the quality of the final ESD surface.
- Optimizing the ESD/UIT process requires consideration of the electrode and substrate interactions and the desired properties. A detailed ESDPS, ESD procedure specification is required if consistent reliable properties are to be expected.

A8. REFERENCES

1. R. N. Johnson., "Principles and Applications of Electro-Spark deposition", Surface Modification Technologies, 117th TMS annual meeting, 1988, January 25-28.
2. R. N. Johnson., (1984). "Coatings for Fast Breeder Reactor Components", presented at Int. Conf. on Metallurgical Coatings, San Diego, April, 1984, Thin solid films, Vol. 118, No.1, pp. 31-47.
3. G.L.Sheldon and R.N.Johnson. "Electro-Spark Deposition- A Technique for producing wear resistant coatings", Wear of materials 1985, ed. K.C. Ludema (New York: ASME, 1985), 388-396.
4. R. N. Johnson and G.L.Sheldon. "Advances in the Electro-spark deposition coating process" presented at Metallurgical Coatings Conference, April, 1986.
5. A. Lesnjak, J. Tusek, Processes and properties of deposits in electro-spark deposition, Science and Technology of Welding and Joining, Dec 2002,7(6): 391-396
6. Portland State University, "ESD Automation Final Report" ASAP Inc, Propulsion Environmental Working Group, (PEWG).Project number 9908, October 2004.
7. Portland State University "Automation Continuation Project report" ASAP PEWG project 10233, November 2005.
8. J. Kelley, "ElectroSpark deposition Technology", Advanced Surfaces and processes, Inc. January 24, 2006
9. N.Price, "Results of materials testing for ElectroSpark deposition", presented at ESTCP/ HCAT Meeting. January 26, 2006
10. E.Sh. Statnikov, "Physics and mechanism of ultrasonic impact treatment", IIW Document XIII-2004-04
11. E.Sh. Statnikov, "Applications of Operational Ultrasonic Impact Treatment (UIT) Technologies in Production of Welded Joints", IIW, Doc. XIII-1667-97.
12. E.Sh. Statnikov, "Comparison of Post-Weld Deformation Methods for Increase in Fatigue Strength of Welded Joints". IIW Doc.XIII-1668-97.
13. E.Sh. Statniko, L.V. Zhuravlev, A.F. Alekseev et al., Ultrasonic Head for Strain Hardening and Relaxation Treatment (in Russian), USSR Inventor's Certificate No. 472782, Published in Byull. Izobret, No. 21 (1975).
14. E.Sh. Statnikov , Ultrasonic Impact Methods for Treatment of Welded Structures, US Patent 6, 171, 415 B1 (2001).
15. E.Sh. Statnikov, Means and Method for Electro acoustic Transducer Excitation, US Patent 6,289,736 B1 (2001).
16. E.Sh. Statnikov, Ultrasonic Machining and Reconfiguration of Braking Surfaces, US Patent 6,458,225 (2002).
17. E.Sh. Statnikov, Ultrasonic Impact Methods for Treatment of Welded Structures, US Patent 6,338, 765 (2002).
18. E.Sh. Statnikov, Ultrasonic Machining and Reconfiguration of Braking Surfaces, US Patent 6,722,175 (2004).
19. E.Sh. Statnikov , Ultrasonic Impact Methods for Treatment of Welded Structures, US Patent Application 10/015,670.

20. E.Sh. Statnikov, Ultrasonic Impact Machining of Body Surfaces to Correct Defects & Strengthen Work Surfaces, US Patent Application 10/207, 859.
Acknowledgements
21. J.J. Ruschau, Influence of Electro-Spark Deposited (ESD) Coatings on the Fatigue Performance of High Strength Steel, University of Dayton Research Institute report #UDR-TR-2002-00016, 2002.

A9. Acknowledgements

This material is based upon work supported by, or in part by, the U. S. Army Research Laboratory and the U. S. Army Research Office under contract/grant number W911NF-08-1-0046. Special thanks to John Kelley, Advanced Surfaces and Processes Inc for providing the Stellite 21 ESD electrode material and suggested ESD parameters for this material, and for providing the manual ESD final fill of the ESD valleys in the fatigue sample divots; to Taylor Hanes, Esonix for making the Ultrasonic Impact Treatment system available; Dave Wert, Carpenter Technology for helpful discussions and for converting C465 and S53 billets to laboratory friendly dimensions; to PSU research staff, Robert Turpin, Tom Quale, Tony Yao, Jack McCarthy, and graduate students Jyothi Kadali and RajaSekar Talla.

A10.List of Tables and Figures

Tables

1. Chemical Composition of Stellite 21 electrode and Steel substrate materials
2. Heat Treatment Schedule
3. ESD parameters
4. ESD Test Matrix
5. UIT test matrix, 0.125inch diameter UIT pin
6. UIT test matrix, 0.250 inch diameter UIT pin
7. Etchants used and etching times for metallographic imaging
8. Test conditions for Residual stress measurements on 300M and C465 alloy
9. Tensile properties of the substrate alloys
10. Chemical composition of each spectrum location in figure 23.
11. Surface Residual stress level for base metal, ESD, and UIT&ESD treated samples
12. Fatigue lives of ESD and ESD/UIT 4340 and C465 as a percentage of base metal fatigue live

Figures

1. (a) 0.125 inch diameter electrode with tip at a 45° angle, (b) electrode rotation, cutting motion
2. ESD Equipment package (ASAP, Inc.)
3. Manual ESD operation Gas cup provides electrode and deposit shielding
4. MOTOMAN SV3X Robot with PushCorp force control unit
5. Movement options of the MOTOMAN SV3X
6. ESD torch with electrode and gas supply hose
7. (a) SEM image of ESD splats (b) single ESD splat of 0.02 in diameter (c) Single ESD Pass with electrode travel speed of 0.21 in/sec,(d) Schematic illustration of ESD on steel substrate- each ESD layer deposited perpendicular to previous layer.
8. Manually operated, hand held, UIT system
9. Semi automated ultrasonic Impact treatment system
10. (a) UIT 1/8" and 1/4" carbide pins (b) &(c) 50 % overlap of UIT pass on ESD, 1/4" pin
11. ESD test coupon with three sections- ESD, ESD+UIT & UIT+ESD
12. Knoop microhardness profile for Custom 465 aged for 4hrs at 950°F
13. Optical image of the indents matrix on Stellite 21 ESD on Custom 465 alloy
14. Optical micrograph and SPM image showing 60X60 indent array
15. ESD and UIT test coupons for Residual stress measurements
16. Schematic drawing of the tapered constant stress bending fatigue sample
17. Schematic illustration of an.250inch thick blank from which 2 fatigue samples are prepared. The round cross hatched areas represent the divot to which ESD or ESD/UIT is applied.
18. Fatigue sample positioned in the Fatigue dynamics flex bending test system. The fixed end is on the left. The narrow end of the sample is attached to the eccentrically rotated crank arm to result in a fixed deflection bending moment stress.
19. (a) C465 aged @ 950°F, ESD-18 layers (b) 300M tempered @ 400F, ESD-6 layers Stellite 21 electrode
20. (a) C465 aged @ 950°F, ESD-18 layers (b) 300M tempered @ 400F, ESD-6 layers Stellite 21 electrode
21. SEM Cross section image for C465 aged @ 950°F
22. SEM image showing lath martensite in C465 alloy aged at 950°F
23. EDX map of C465 aged @ 950F; Stellite 21 ESD electrode; Yellow line scan on right represents Fe.

24. ESD of Stellite 21 on C465 alloy (a) without UIT (b) with UIT
25. Microhardness profile of C465 aged at 950°F-18 ESD layers
26. TEM micrograph showing martensite laths in Custom 465 substrate aged at 950°F and corresponding SAD pattern- no ESD/ UIT treatment
27. TEM dark field image and SAD pattern of precipitates in Custom 465 substrate aged at 950°F –no ESD/UIT treatment
28. TEM micrograph of (a) Stellite 21 deposit on Custom 465 aged at 950°F, (b) Custom 465 substrate-ESD treated
29. (a) Faint spots in SADP indicate precipitates in the substrate (b) SADP of image in fig 28 (b).
30. TEM image of (a) substrate HAZ (b) mixing layers in treated Custom 465 aged at 950°F – ESD+UIT treated
31. TEM micrographs of sample taken at 1mm from UIT surface for Custom 465 aged at 950°F – UIT treated
32. TEM micrographs of sample taken at 1mm from UIT surface for Custom 465 aged at 950°F (a) Interface of fine and coarse martensite laths (b) SADP of image in 32a- UIT treated
33. TEM micrographs of sample taken at 6mm from UIT surface for Custom 465 aged at 950°F – UIT treated
34. TEM micrograph and SADP of sample taken at 6mm from UIT surface for Custom 465 aged at 950°F – UIT treated
35. TEM image of precipitates in sample taken at 6mm from UIT surface for Custom 465 aged at 950°F – UIT treated
36. (a) TEM micrograph of sample taken at 6mm from UIT surface for Custom 465 aged at 950°F (b) &(c) SADP of image in figures 35&36, (d) Micro diffraction of image in figure 35b – UIT treated
37. Hardness profile for ESD of Stellite 21 on aged Custom 465 alloy
38. Application of UIT after ESD of stellite 21 on aged Custom 465 alloy
39. ESD of stellite 21 on UIT treated Custom 465 alloy
40. Hardness depth profile for aged C465 alloy treated with two UIT pin sizes
41. Hardness depth profile for ESD+UIT on C465 aged @ 950°F with two UIT pin sizes
42. Hardness depth profile for aged C465 alloy with 2 UIT intensities
43. Hardness depth profile for ESD with UIT travel speed numbers 14,20,& 28 on Custom 465
44. Hardness depth profile comparison for UIT treated surface - UIT travel speed numbers 14, 20 & 28.
45. Color maps of the hardness and modulus SPM image of the test area
46. Average hardness of each column of indents from the 10x10 array, error bars represent 1 standard deviation
47. Average modulus of each column of indents from the 10x10 array, error bars represent 1 standard deviation
48. Residual stress depth profile for Custom 465 aged at 950°F
49. Fully reversed, R= -1, fatigue curve for reference 4340 tempered at 400°F. data points only; baseline, ESD and ESD+UIT conditions. The ESD/UIT data are for incompletely ESD filled divots+UIT. The ESD/UIT data marked with a star are for improved fill ESD+UIT.
50. Same as previous figure but with manually drawn trend lined added
51. Same as figure 50 but with manual trend lines only

52. Fully reversed, R= -1, fatigue curve for C465 aged at 950°F; baseline, ESD, and ESD+UIT conditions.
53. Same as figure 52 but with manually drawn trendlines added, Circled data ignored.
54. Same as figure 53 but without data points included
55. Fully reversed, R= -1, fatigue curve for C465 aged at 1000°F; baseline, ESD, and ESD+UIT conditions.
56. Fully reversed, R= -1, fatigue curve for C465 aged at 1000°F; baseline, ESD and ESD+UIT, manual trend lines added.
57. Same as figure 56 but with only trend lines shown
58. Fully reversed, R= -1, fatigue curve for C465 aged at 950°F and at 1000°F; baseline, ESD and ESD+UIT, trend lines drawn manually
59. Fully reversed, R= -1, base line fatigue curve for each alloy
60. Same as figure 59 except wth manual trend lines added
61. Same as figure 60 with only trend line shown.
62. UIT treatment on both sample sides at radius to clamped wide shoulder
63. 4340 baseline fatigue sample, 200ksi max stress, 72,000 cycle life
64. 4340 baseline fatigue sample, 176ksi max stress, 300,000 cycle life
65. 4340 +ESD fatigue, top view, failed through incompletely filled ESD
66. 4340+ESD enlarged view of previous image showing multiple fatigue initiation sites from ESD deposit
67. 4340 +ESD top view, ESD as deposited and underfilled
68. 4340+ESD, top surface surface ground after ESD; ESD fill incomplete
69. 4340+ESD+UIT, surface ground after UIT, incomplete ESD fill area
70. 4340+ESD+UIT, surface ground after UIT revealing incomplete ESD fill areas
71. 4340+ESD+UIT, top view, failed outside of ESD+UIT area(top center)
72. Enlarged view of previous figure showing non propagating cracks in ESD+UIT deposit, fracture surface below bottom edge of field of view
73. C465 aged at 1000°F, baseline fatigue fracture surface showing much coarser grain size than 4340 and evidence of subsurface cracking
74. C465 aged at 1000°F, ESD+UIT, top view showing incomplete ESD fill after surface grinding flush with base sample. Cracking started at left, right, and middle incomplete fill areas
75. C465 aged at 950oF, ESD, fatigue fracture surface showing multiple crack initiation from ESD treated surface
76. Enlarged view of previous figure showing coarse grain size and cracks initiating from top ESD surface
77. C465 aged at 950°F, ESD + surface ground complete ESD fill, fracture occurred through the middle of the ESD deposit

A11. Tables and Figures

Table 1: Chemical Composition of Stellite 21 electrode and Steel substrate materials

Material	Fe	Co	Cr	Mo	Ni	Ti	C	Mn	S	Si	W	V	P
Stellite 21	3.0	Bal	29	6	3	-	0.35	1.0	-	1.0	-	-	-
4340	Bal	-	.79	.25	1.75	-	0.39	.79	0.01	.25	-	-	0.01
300M	Bal	-	0.95	0.65	2.0	-	0.46	0.9	0.01	1.8	-	0.05	0.01
Custom 465	Bal	-	12.5	1.25	11.25	1.8	0.02	0.25	0.010	-	-	-	-
FerriumS-53	Bal	14	10	2.0	5.5	-	0.2	-	-	-	1.0	0.3	-

Table 2: Heat treatment schedule

300M	(a)Solution HT@1600°F for 1hr, oil quenched & tempered @ 400°F for 2hrs & air cooled (b)Solution HT@1600°F for 1hr, oil quenched & tempered @ 575°F for 2hrs & air cooled.
4340	Solution HT @1550°F for 1hr, oil quench and tempered @400°F for 2 hours & air cool
Custom 465	(a) Solution Annealed to 1800°F for 1hr , refrigerated to -100F for 8hrs ,warming to RT followed by aging @ 1000°F for 4hrs and air cool (b) Solution Annealed to 1800°F for 1hr , refrigerated to -100°F for 8hrs , warming to RT followed by aging @ 950°F for 4hrs and air cool.
Ferrium S-53	Solution HT @ 1985°F for 1hr , oil quench, refrigerated to -100°F for 1hr , air warm, tempered @ 934°F for 3hrs, oil quench, refrigerated to -100°F for 1hr,air warm followed by second temper @ 900°F for 12 hrs and air cool.

Table 3. ESD parameters

Volts	Amps	RPM	Pulse Rate (Hz)	Capacitance (mF)	Layer pattern	Contact Force (oz)	Shielding Gas	% Overlap
130	4	1200	400	40	Alt 90°	5	Argon	10

Table 4: ESD Test Matrix

Sample	Test date	Material	No of ESD layers	UIT test ID*
1	020209	C465-Annealed	12	
2	030309	C465 1000F	9	
3	030309	C465 1000F	18	
4	080409	C465 1000F	6	080409 D
5	100609	C465 1000F	6	100609 D 0.25
6	091709	C465 1000F	3ESD+UIT+3ESD	091709 D7
7	022409	C465 950F	18	
8	081309	C465 950F	6	081309 C
9	100509	C465 950F	6	100509 C 0.25
10	012309	300M- Annealed	18	
11	021209	300M-Annealed	4	
12	021609	300M-Annealed	6	
13	072809	300M 400F	12	
14	080409	300M 400F	6	080409 A
15	100509	300M 400F	6	100509 A 0.25
16	082609	300M 575F	6	082609 B
17	111309	300M 575F	3ESD+UIT+3ESD	111309B7
17	092209	S53	6	092209 S
18	100909	S53	6	100909 S 0.25

Note : * each UIT test ID in table 4 resembles UIT applied before or after completing 6 ESD runs and for UIT parameters refer to table 5 .

Table.5. UIT test matrix

UIT Testing Matrix for 0.125 inch diameter UIT pin							
Test Name/ Coupon ID	Sample**	Material	Pressure psi	Amplitude Level	% Overlap	Travel speed (inch/sec)*	Test Condition
081309 C	C1	C465 950F	35	2	50%	0.12	UIT
	C2	C465 950F	38	4	50%	0.12	UIT
	C3	C465 950F	35	2	50%	0.12	Before ESD
	C4	C465 950F	38	4	50%	0.12	Before ESD
	C5	C465 950F	35	2	50%	0.12	After ESD
	C6	C465 950F	38	4	50%	0.12	After ESD
080409 D	D1	C465 1000F	35	2	50%	0.12	UIT
	D2	C465 1000F	38	4	50%	0.12	UIT
	D3	C465 1000F	35	2	50%	0.12	Before ESD
	D4	C465 1000F	38	4	50%	0.12	Before ESD
	D5	C465 1000F	35	2	50%	0.12	After ESD
	D6	C465 1000F	38	4	50%	0.12	After ESD
091709 D7	D7	C465 1000F	38	4	50%	0.12	Before & After ESD
080409 A	A1	300M 400F	38	4	50%	0.12	UIT
	A2	300M 400F	40	6	50%	0.12	UIT
	A3	300M 400F	42	8	50%	0.12	UIT
	A4	300M 400F	38	4	50%	0.12	Before ESD
	A5	300M 400F	40	6	50%	0.12	Before ESD
	A6	300M 400F	42	8	50%	0.12	Before ESD
	A7	300M 400F	38	4	50%	0.12	After ESD
	A8	300M 400F	40	6	50%	0.12	After ESD
	A9	300M 400F	42	8	50%	0.12	After ESD
082609 B	B1	300M 575F	38	4	50%	0.12	UIT
	B2	300M 575F	40	6	50%	0.12	UIT
	B3	300M 575F	38	4	50%	0.12	Before ESD
	B4	300M 575F	40	6	50%	0.12	Before ESD
	B5	300M 575F	38	4	50%	0.12	After ESD
	B6	300M 575F	40	6	50%	0.12	After ESD
111309B7	B7	300M 575F	38	4	50%	0.12	Before & After ESD
092209 S	S1	S53	38	4	50%	0.12	UIT
	S2	S53	40	6	50%	0.12	UIT
	S3	S53	38	4	50%	0.12	Before ESD
	S4	S53	40	6	50%	0.12	Before ESD
	S5	S53	38	4	50%	0.12	After ESD
	S6	S53	40	6	50%	0.12	After ESD

Note: ** UIT pressures are adjusted according to the intensity level for each test and therefore each sample is given different identification, i.e. for Coupon **081309 C** each test with different pressures, amplitude levels and UIT test condition is identified as C1, C2 and so on.

Table.6. UIT test matrix

UIT Test Matrix for 0.25 inch diameter UIT pin							
Test name/ Coupon ID	Sample	Material	Pressure psi	Amplitude Level	% Overlap	Travel speed (inch/sec)	Test Condition
100509 C 0.25	C7	C465 950F	45	5	50%	0.12	UIT
	C8	C465 950F	45	5	50%	0.12	After ESD
100609 D 0.25	D8	C465 1000F	45	5	50%	0.12	UIT
	D9	C465 1000F	45	5	50%	0.12	After ESD
100509 A 0.25	A10	300M 400F	45	5	50%	0.12	UIT
	A11	300M 400F	45	5	50%	0.12	After ESD
100909 S 0.25	S7	S53	45	5	50%	0.12	UIT
	S8	S53	45	5	50%	0.12	After ESD

Table 7. Etchants used and etching times for metallographic imaging

Alloy	Etchant	Exposure time
300M	2% Nital	20sec
C465	Waterless Kalling's	25sec
S-53	Ralph's Reagent	30sec

Table.8. Test conditions for residual stress measurements on 300M and C465 alloy

300M tempered @ 400F	Custom465 aged @ 950F
Base material, no UIT	Base material, no UIT
UIT, intensity 4	UIT, intensity 2
UIT, intensity 6	UIT, intensity 4
ESD+UIT intensity 4	ESD+UIT intensity 2
ESD+UIT intensity 6	ESD+UIT intensity 4
UIT(4)+ESD	UIT(2)+ESD
UIT(6)+ESD	UIT(4)+ESD
ESD	ESD

Table 9 Tensile properties of heat treated substrate ultra high strength alloys

alloy	.2% YS ksi	UTS ksi	Elong %	RA %	Modulus 10 ⁶ psi	Poisson's ratio	Hardness HRC
300M@400°F	242	306	12	31	30.9	.31	53
300M@575°F	225	299	12	33	32.6	.31	53
C465@950°F	239	254	11	52	30.2	.31	51.3
C465@1000°F	219	230	12	61	29.9	.31	47.6
S53@934/900°F	232	284	14	55	31.1	.31	52.7
4340@400°F	223	280	13	52	30.2	----	52

Table 10: Chemical composition of each spectrum location in figure 23.

Element	Chromium	Iron	Cobalt	Nickel	Titanium
Stellite 21	26.69	2.71	55.39	2.93	--
Spectrum 4	25.56	6.70	52.87	3.94	--
Spectrum 5	21.17	29.78	36.61	6.00	0.58
Spectrum 6	12.85	70.33	3.13	10.70	1.36
Spectrum 7	11.90	71.47	0.00	10.19	1.43
Spectrum 8	11.76	73.03	0.00	10.83	1.54
Substrate	11.72	73.27	0.00	10.85	1.60

Table 11. Surface Residual stress level for base metal, ESD, and UIT&ESD treated samples

Alloy	Test condition	Stress (Ksi)	Error (estimated by Proto Inc)
300M tempered @ 400F*	Base material, no UIT	-63	± 1
	UIT, intensity 4	-134	± 2
	UIT, intensity 6	-138	± 2
	ESD+UIT intensity 4	-265	± 5
	ESD+UIT intensity 6	-141	± 4
	UIT(intensity 4)+ESD	+58	± 5
	UIT(intensity 6)+ESD	+67	± 5
Custom 465 aged @ 950F*	Base material, no UIT	-30	± 4
	UIT, intensity 2	-196	± 3
	UIT, intensity 4	-176	± 3
	ESD+UIT intensity 2	-215	± 7
	ESD+UIT intensity 4	-241	± 13
	UIT(intensity 2)+ESD	+62	± 5
	UIT(intensity 4)+ESD	+59	± 3
	ESD	+62	± 5

*coupons were surface ground using 240 grit paper after vacuum heat treating, prior to ESD and ESD&UIT treatments.

Table 12 Fatigue Summary: UHSS expressed as a Percentage of base metal fatigue properties

Fatigue summary: UHSS (% of base metal fatigue properties)				
Alloy (temper/age, °F)	Treatment	Fatigue life range		
		100-200K cycles	1M cycles	20M cycles
4340 (400°F)	ESD	50%	35%	
	ESD/UIT (underfilled)	90%	60%	
	ESD/UIT (filled)	95%	95%	95%
C465 (1000°F)	ESD/UIT	95%	83%	77%
C465 (950°F)	ESD/UIT	95%		80%

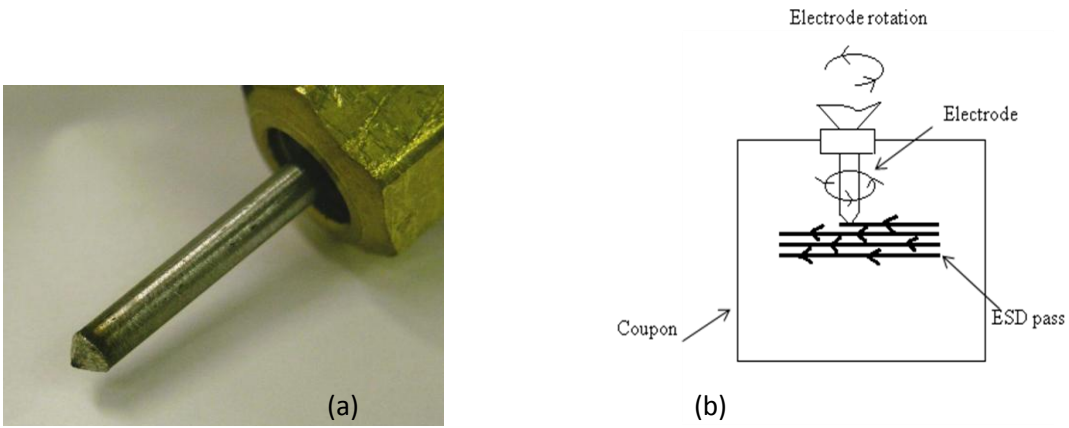

Figure 1(a) 0.125 inch diameter electrode with tip at a 45° angle, (b) electrode rotation, cutting motion

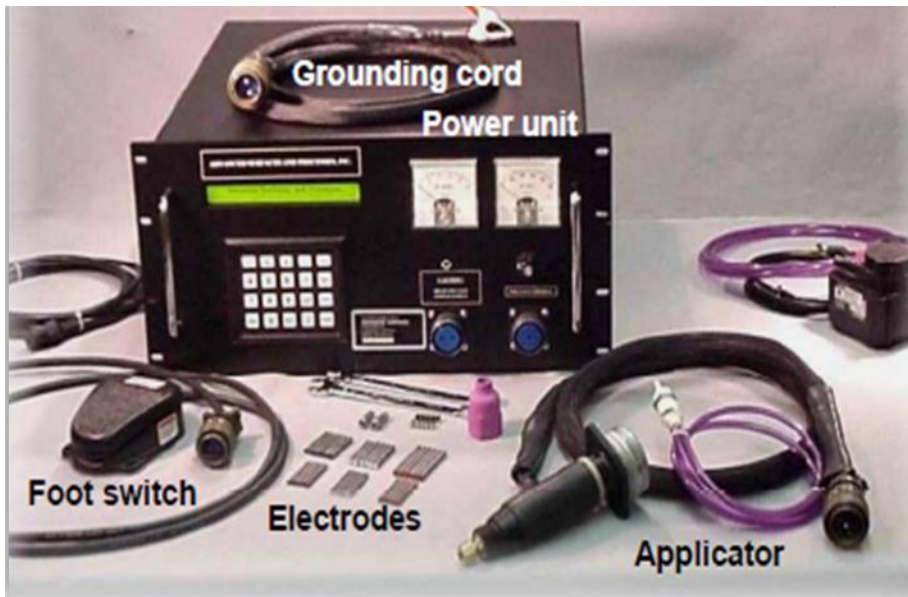

Figure 2: ESD Equipment



Figure 3: Manual ESD operation Gas cup provides electrode and deposit shielding [9]

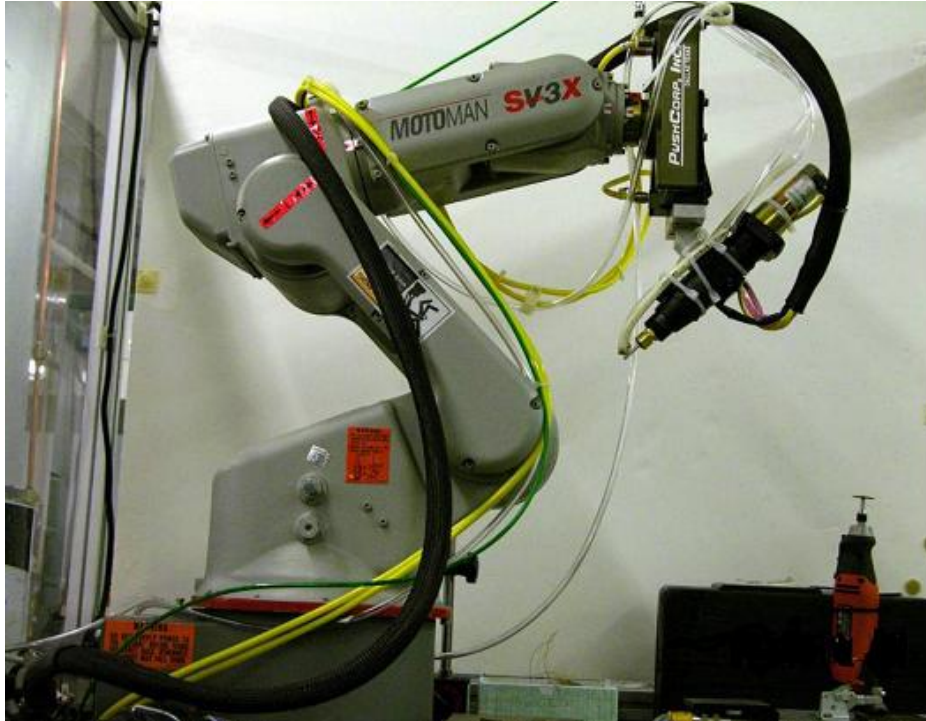

Figure 4: MOTOMAN SV3X Robot with PushCorp force control unit

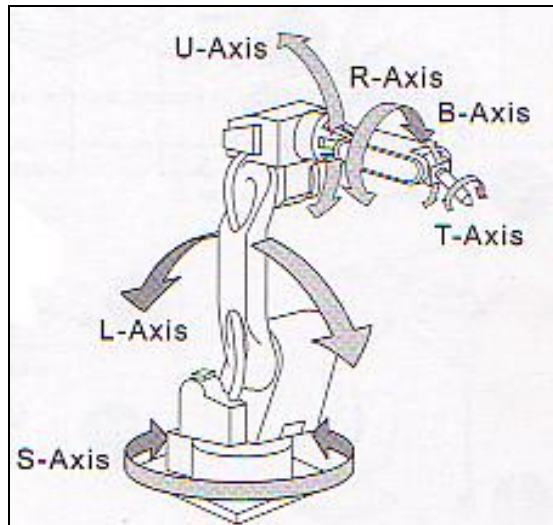

Figure 5: Movement options of the MOTOMAN SV3X

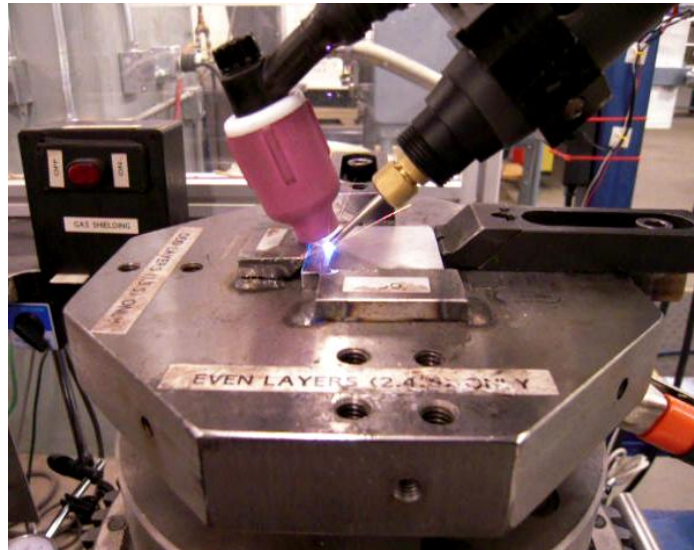

Figure 6: Shows ESD torch with electrode and gas supply hose.

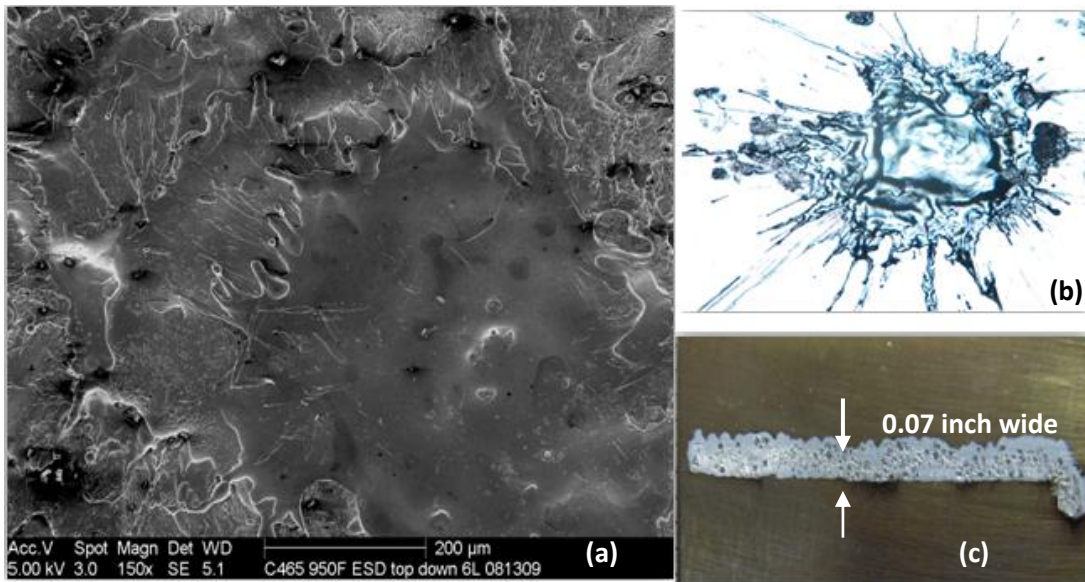

Figure 7: (a) SEM image of ESD splats (b) single ESD splat of 0.02 in diameter (c) Single ESD Pass with electrode travel speed of 0.21 in/sec

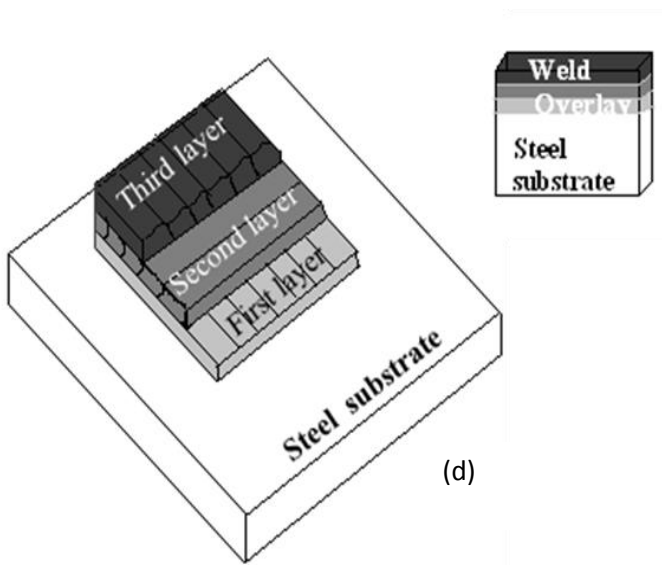

Figure 7 : (d) Schematic illustration of ESD on steel substrate; each ESD layer deposited perpendicular to the previous layer.



Figure 8: manually operated, hand held, UIT system

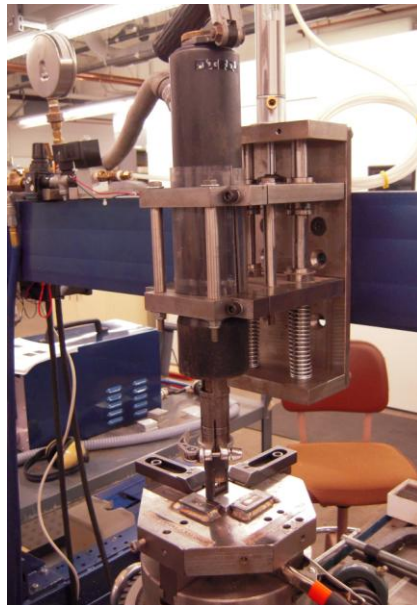

Figure 9: Semi automated ultrasonic Impact treatment system

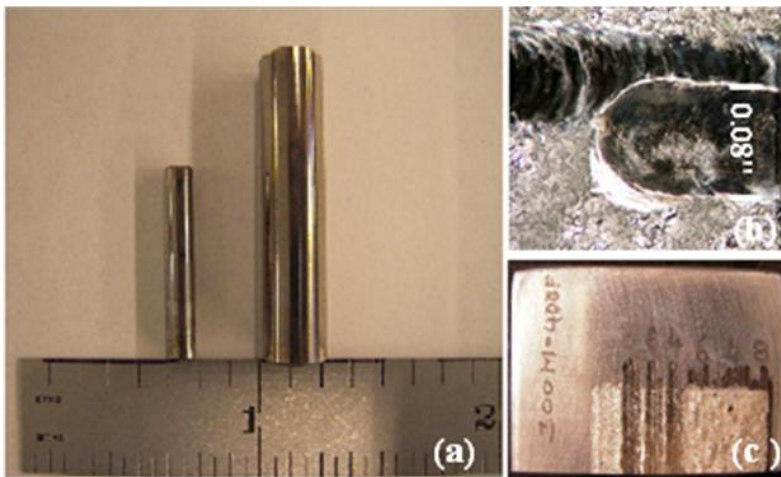

Figure 10 :(a) UIT 1/8" and 1/4" carbide pins (b) &(c) 50 % overlap of UIT pass on ESD, 1/4" pin

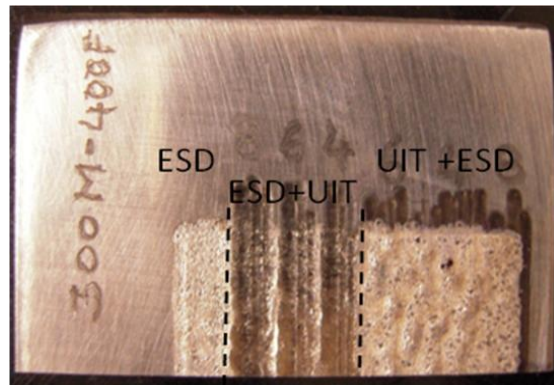

Figure.11. ESD test coupon with three sections- ESD, ESD+UIT & UIT+ESD

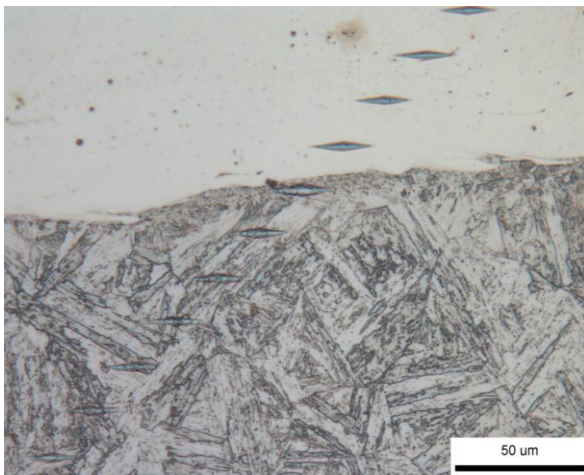

Figure.12. Knoop microhardness profile for Custom 465 aged for 4hrs at 950°F

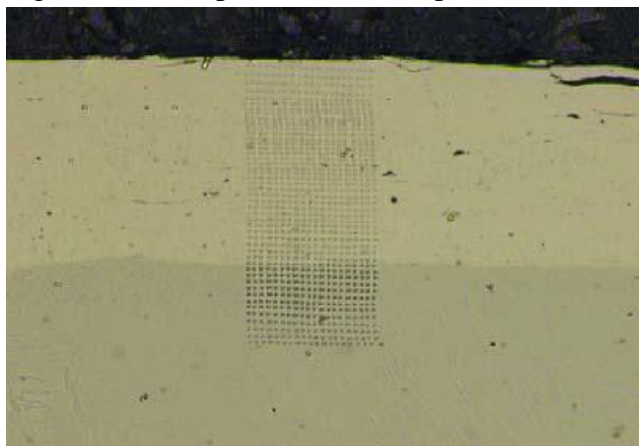

Figure.13. Optical image of the indents matrix on Stellite 21 ESD on Custom 465 alloy.

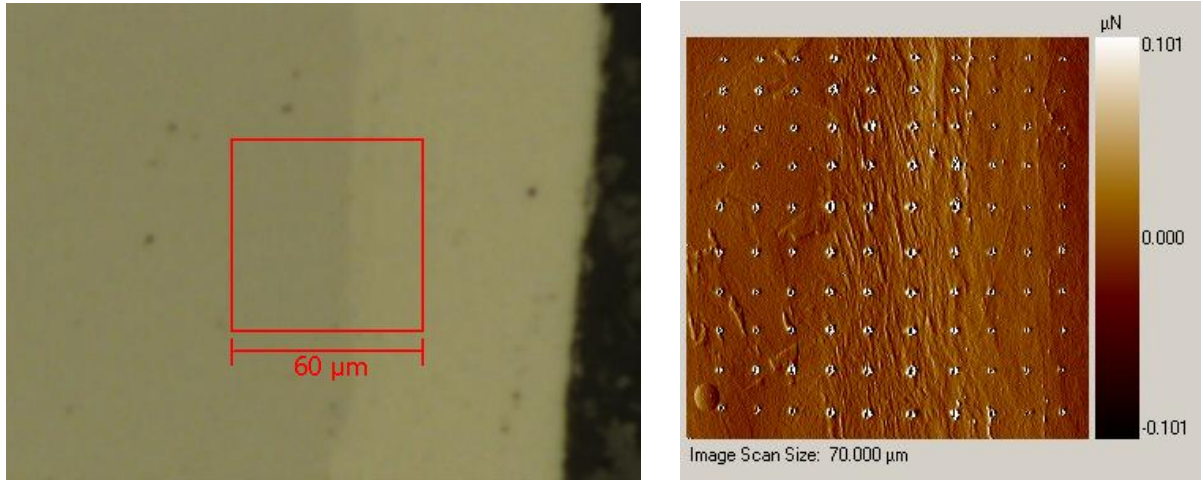

Figure .14. Optical micrograph and SPM image showing 60X60 indent array

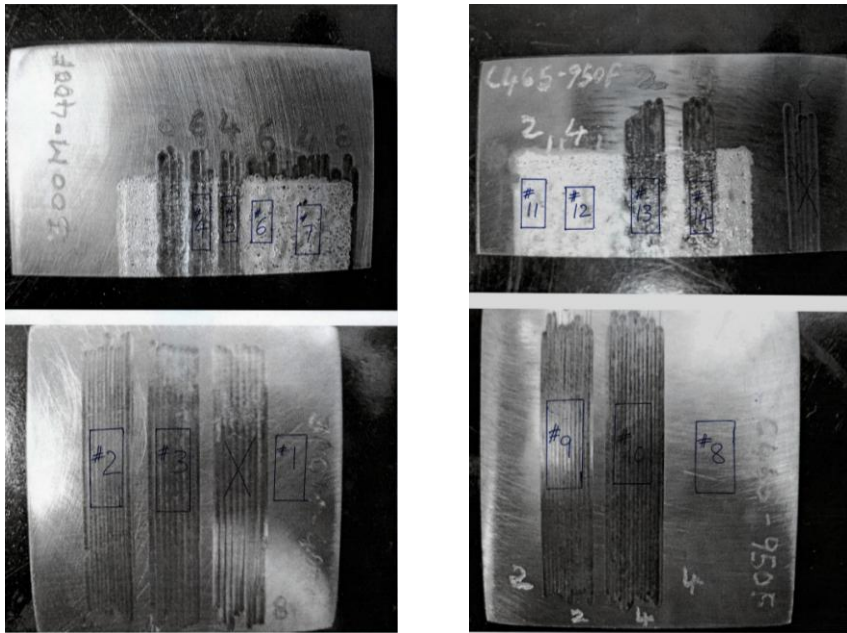

Figure.15. ESD and UIT test coupons for residual stress measurements

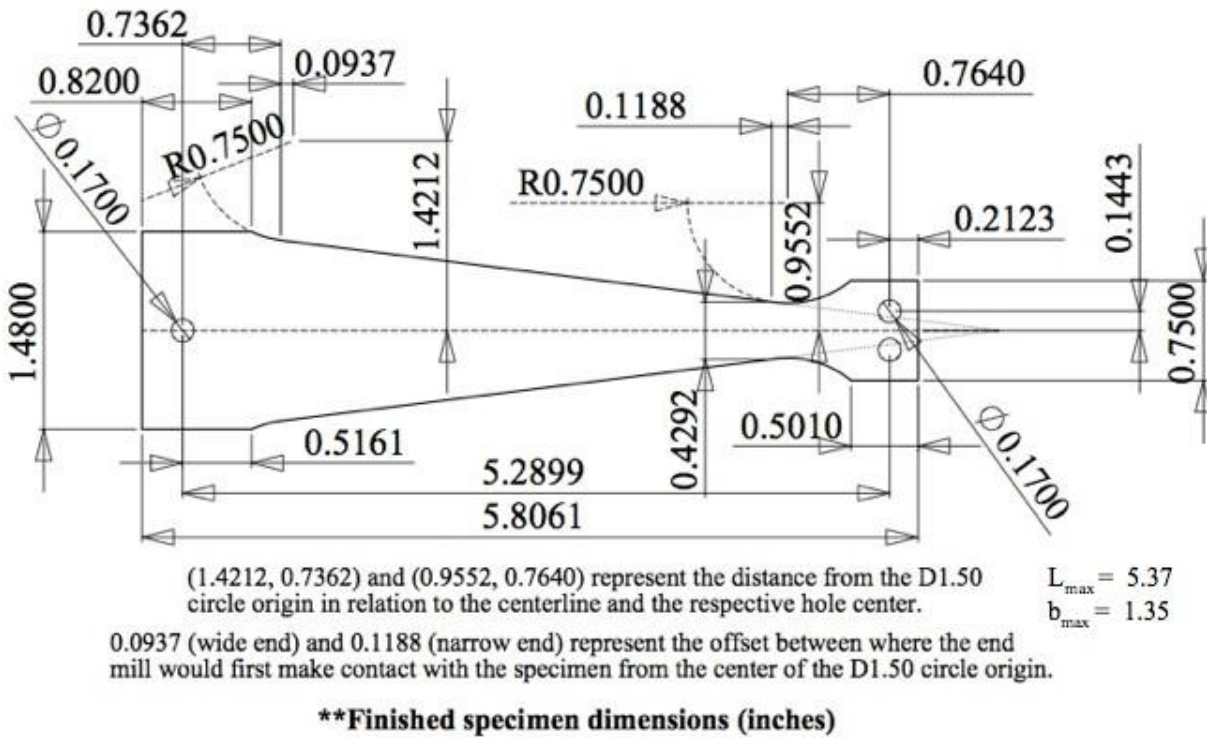

Figure 16 schematic drawing of the tapered constant stress bending fatigue sample

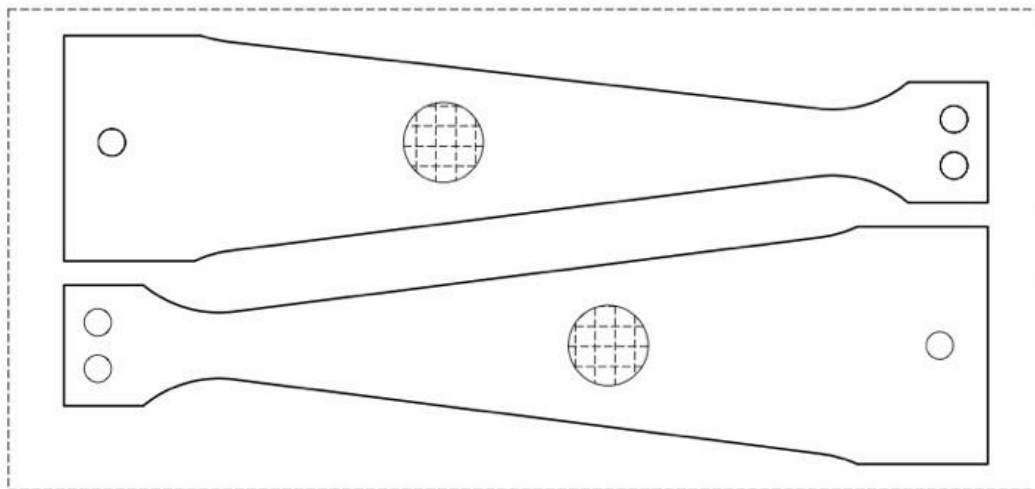

Figure 17 Schematic illustration of an.250inch thick blank from which 2 fatigue samples are prepared. The round cross hatched areas represent the divot to which ESD or ESD/UIT is applied.

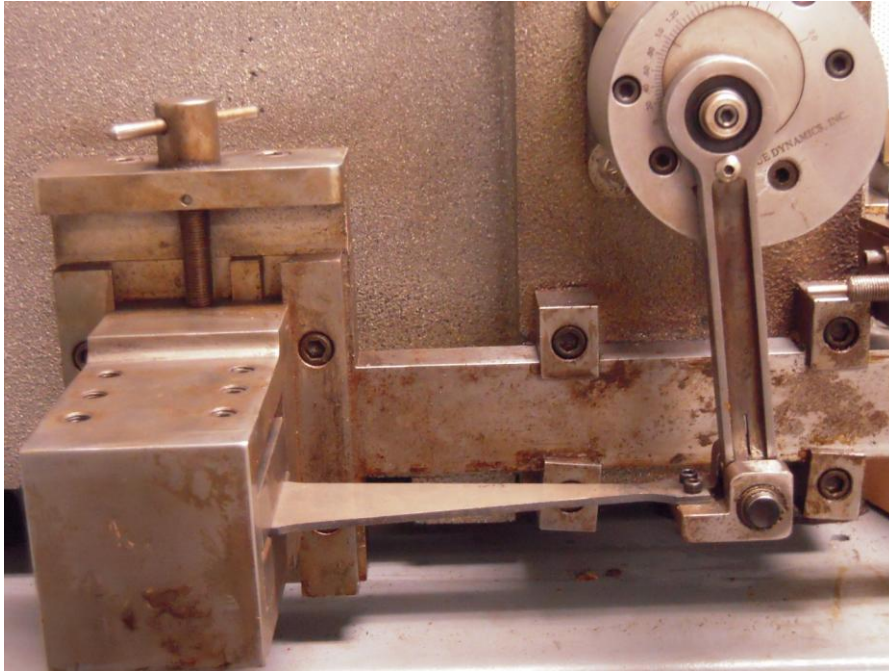

Figure 18 Fatigue sample positioned in the Fatigue dynamics flex bending test system. The fixed end is on the left. The narrow end of the sample is attached to the eccentrically rotated crank arm to result in a fixed deflection bending moment stress

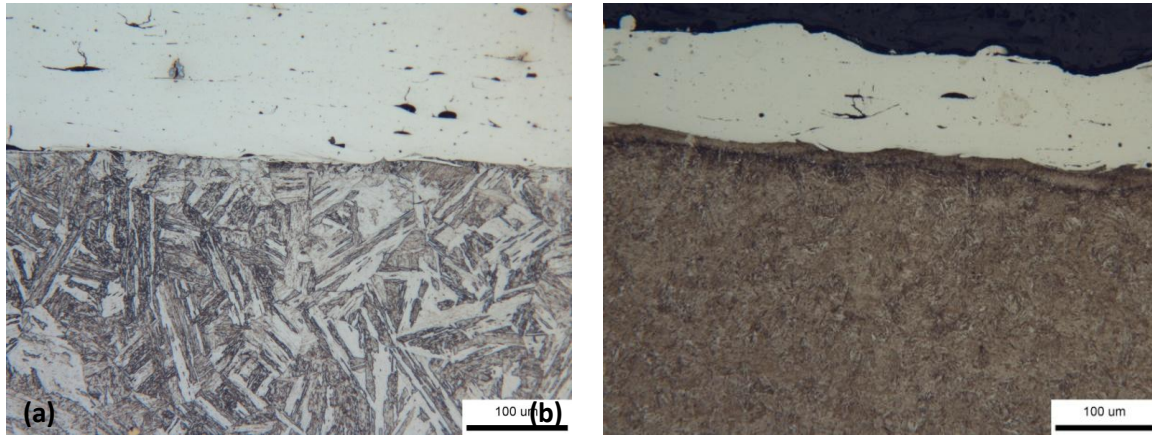

Figure.19. (a) C465 aged @ 950°F, ESD-18 layers (b) 300M tempered @ 400F, ESD-6 layers
Stellite 21 ESD electrode

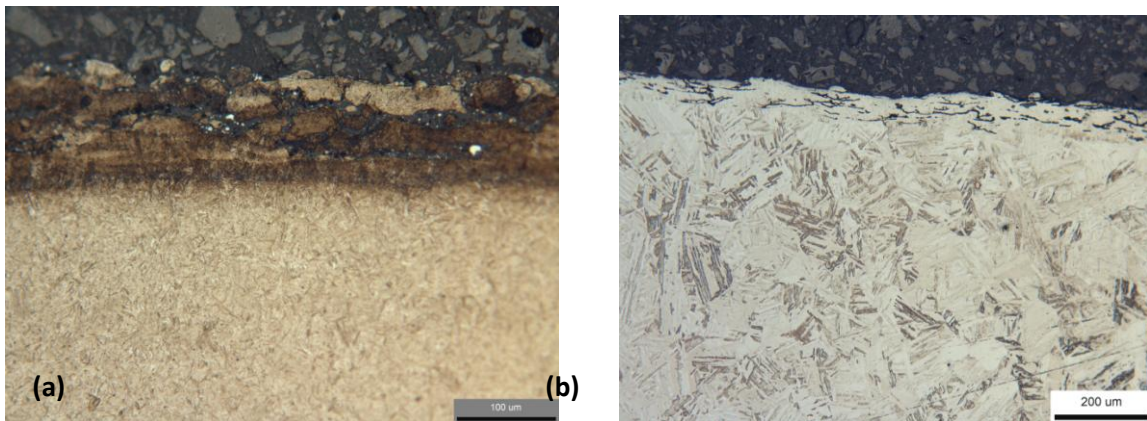

Figure.20. (a) 300M deposited on 300M substrate -19 ESD Layers (200X) (b) C465 deposited on
C465 substrate -9 ESD layers (100X)

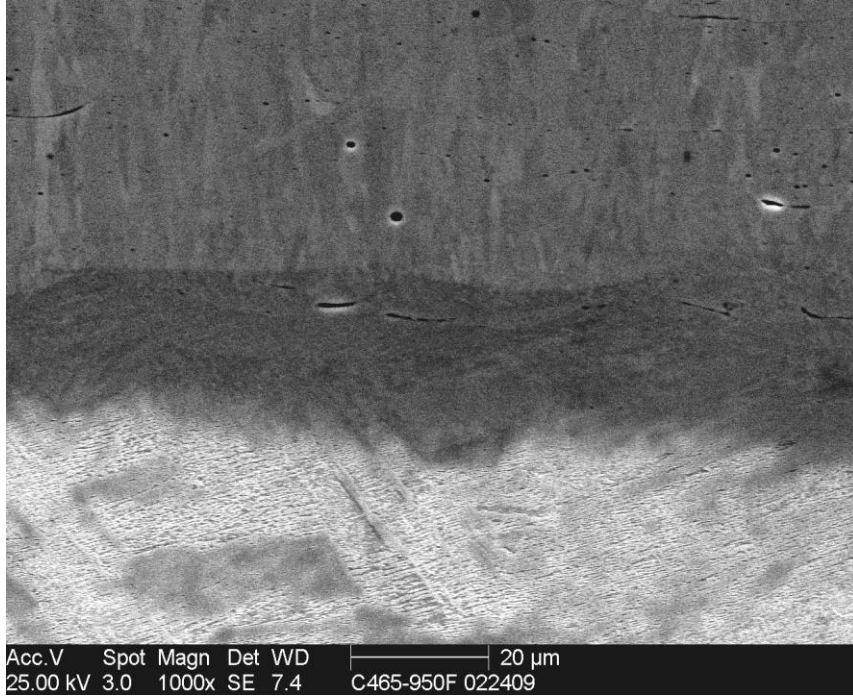

Figure.21. SEM Cross section image for C465 aged @ 950°F

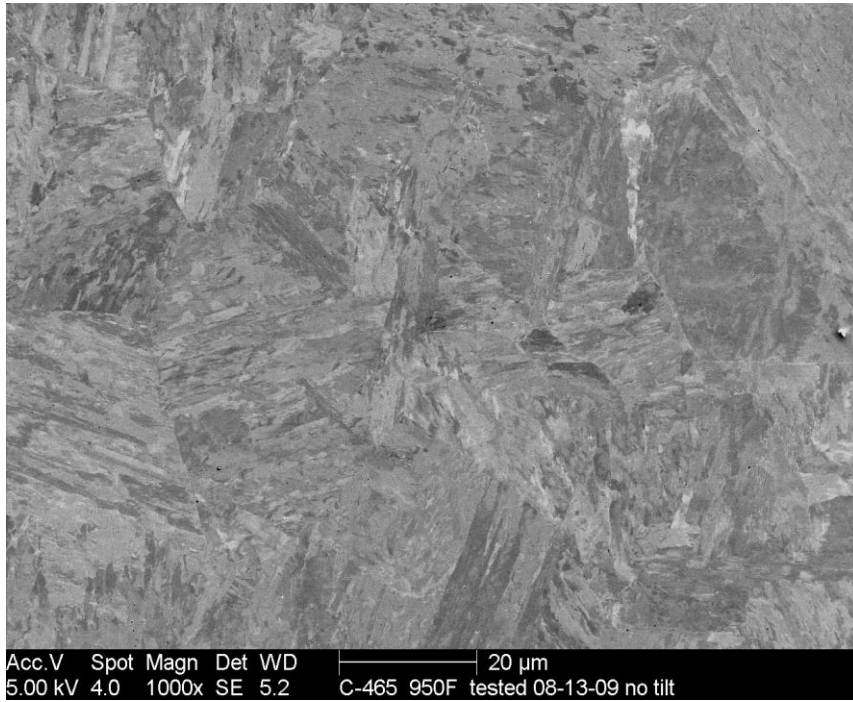

Figure 22 SEM secondary electron image metallography of C465 aged at 950 °F

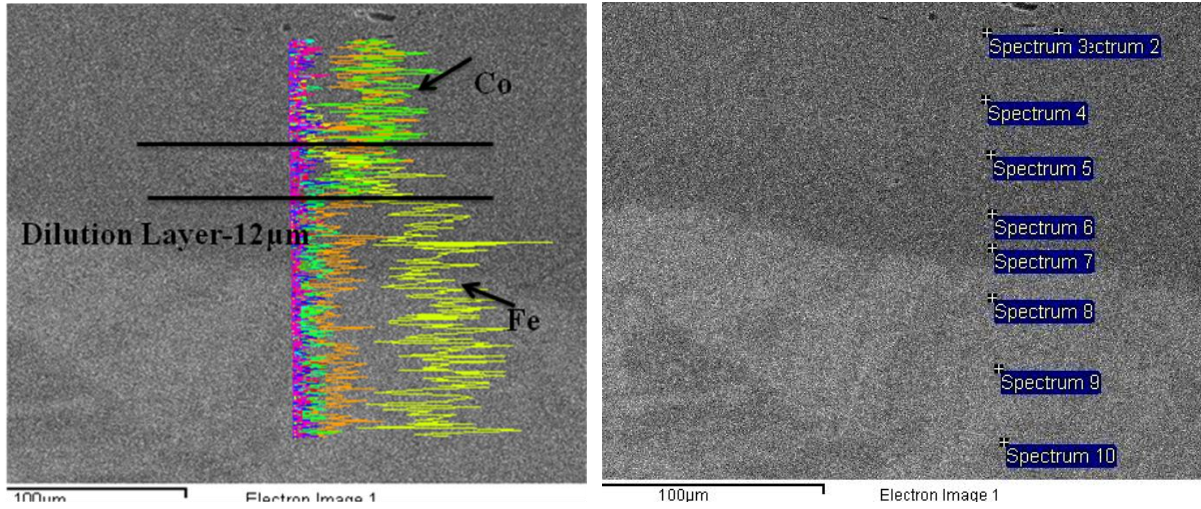

Figure.23. EDX point and line scans, C465 aged @ 950F; Stellite 21 electrode; Fe (yellow), Co (green).

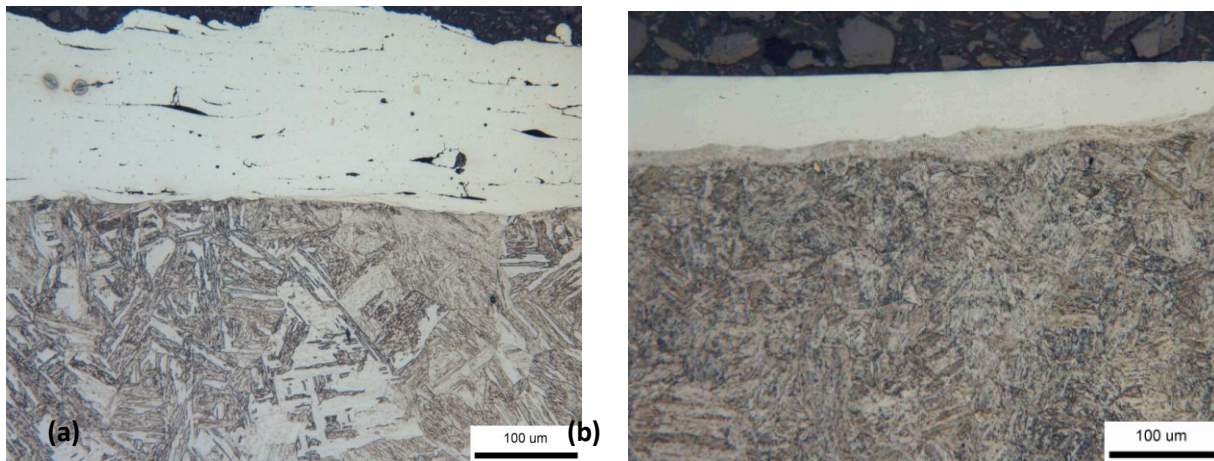

Figure.24. ESD of Stellite 21 on C465 alloy (a) without UIT (b) with UIT

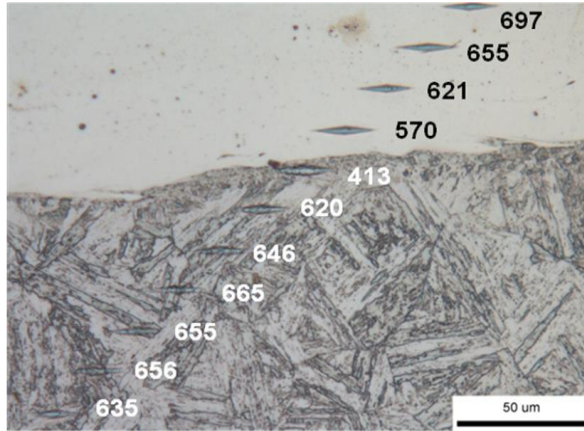

Figure.25. Microhardness profile of C465 aged at 950°F-18 ESD layers

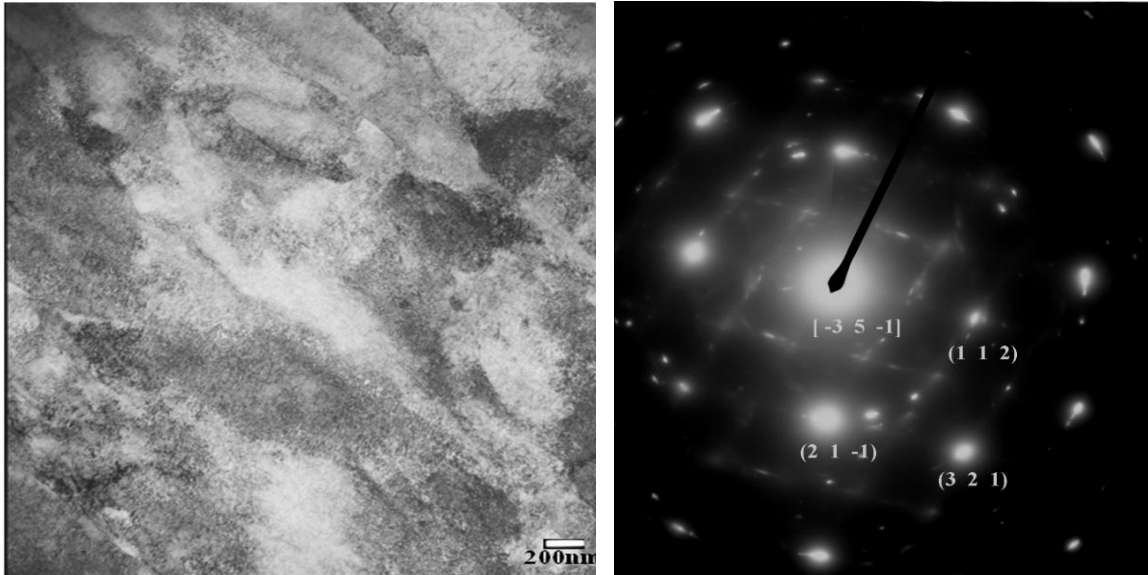

Figure 26: TEM micrograph showing martensite laths in Custom 465 substrate aged at 950°F and corresponding SAD pattern- no ESD/ UIT treatment

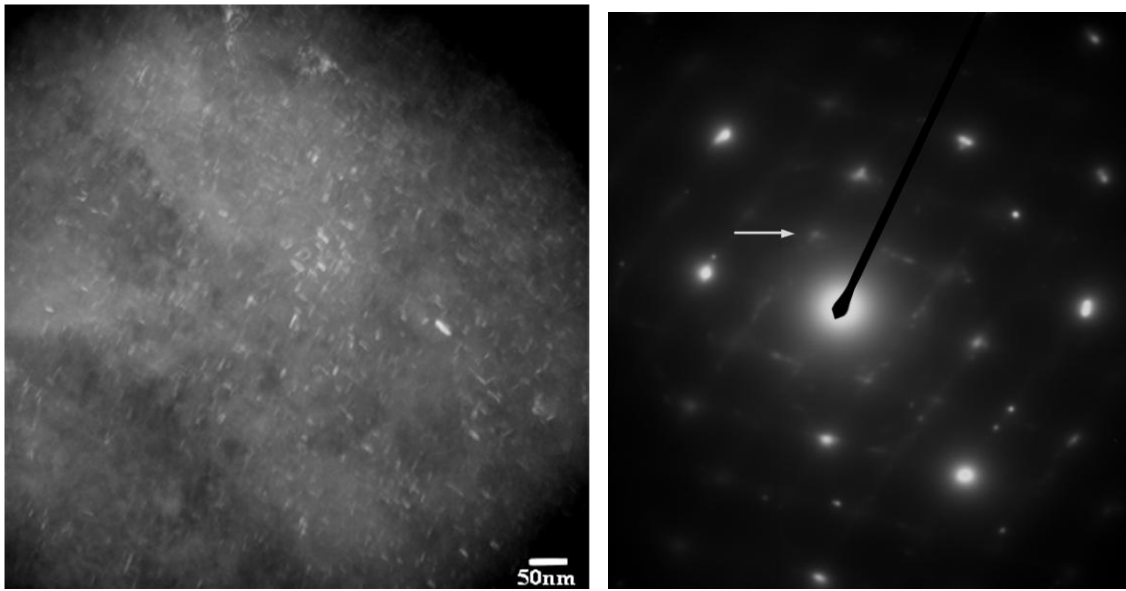

Figure 27: TEM dark field image and SAD pattern of precipitates in Custom 465 substrate aged at 950°F –no ESD/UIT treatment

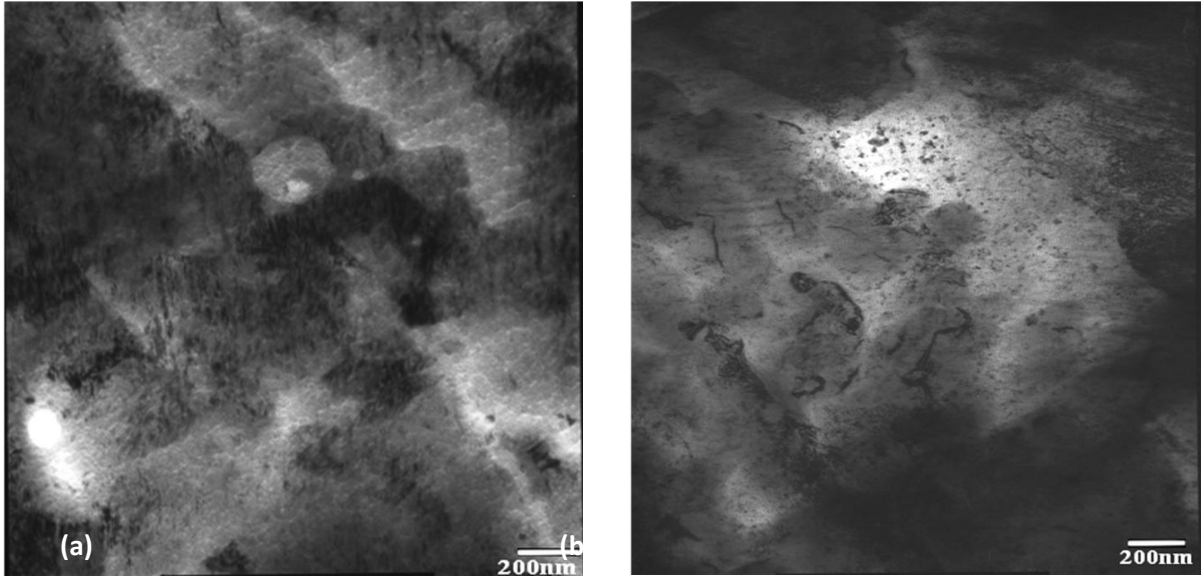

Figure 28: TEM micrograph of (a) Stellite 21 deposit on Custom 465 aged at 950°F, (b) Custom 465 substrate-ESD treated

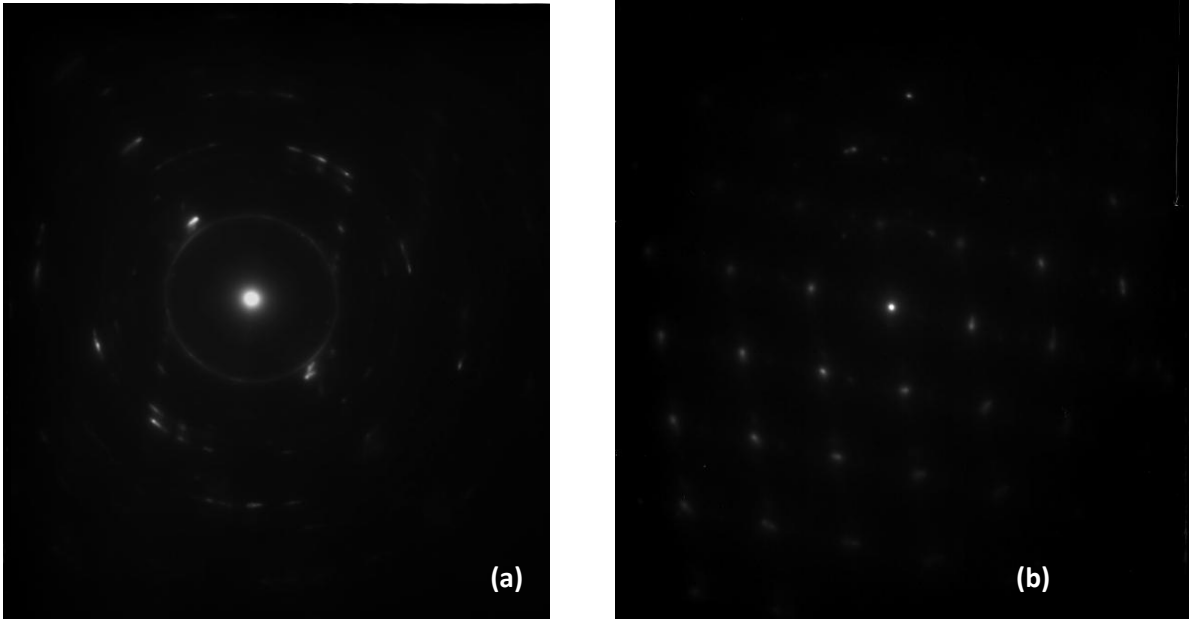

Figure 29: (a) Faint spots in SADP indicate precipitates in the substrate (b) SADP of image in figure 28 (b).

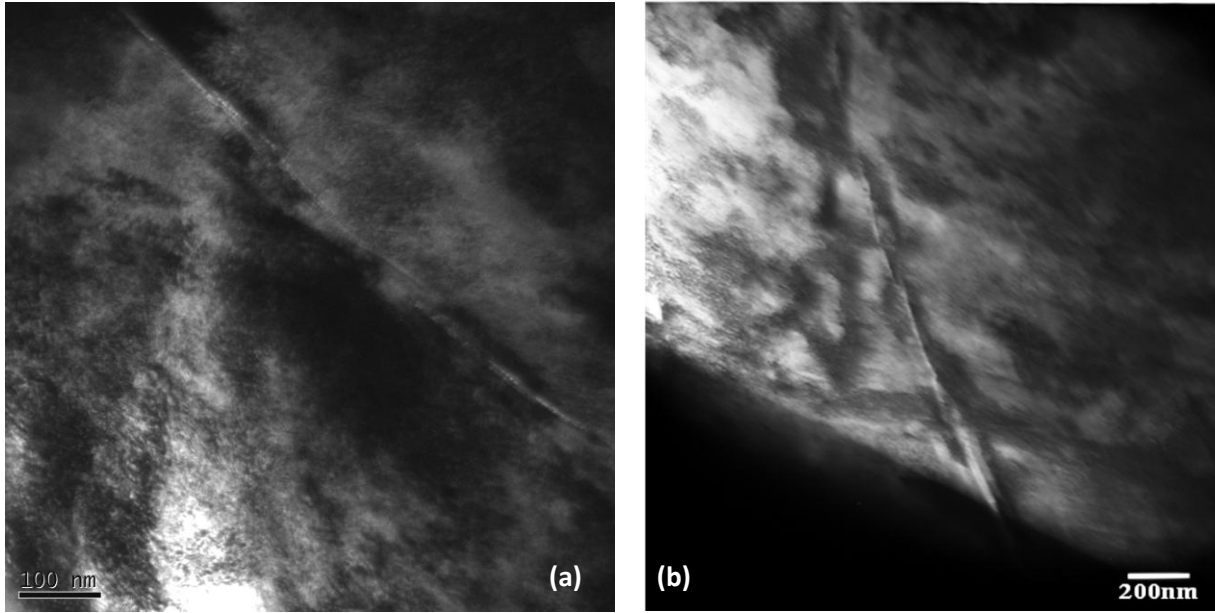

Figure 30: TEM image of (a) substrate HAZ (b) mixing layers in treated Custom 465 aged at 950°F – ESD+UIT treated

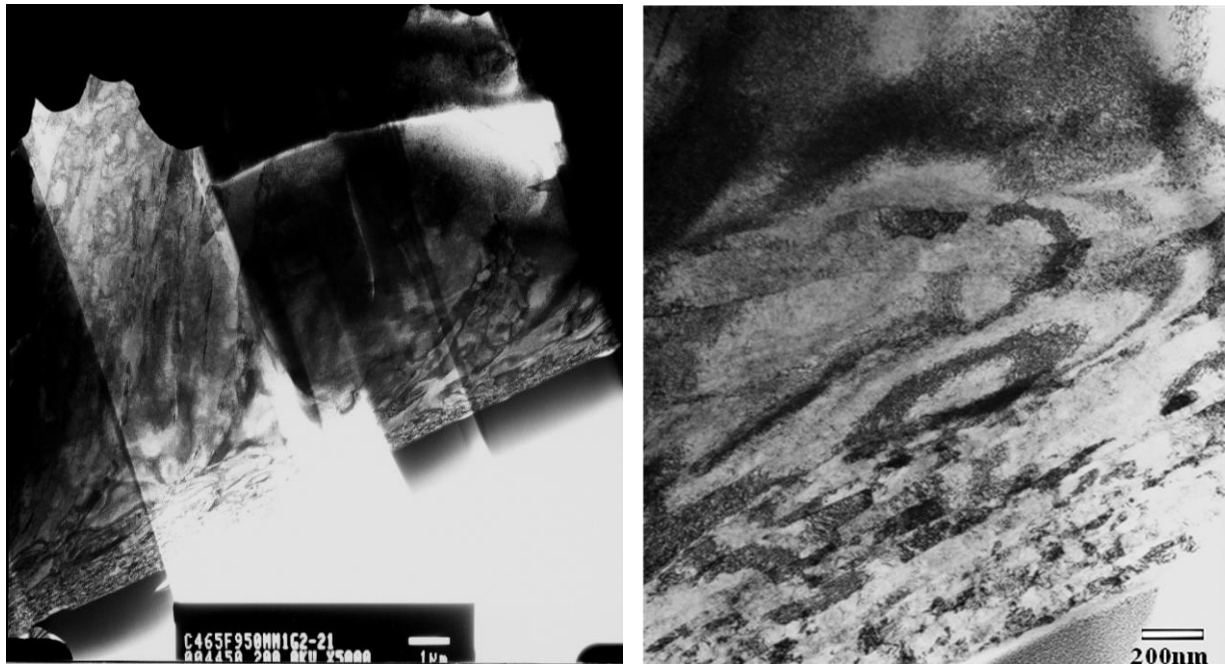

Figure 31: TEM micrographs of sample taken at 1mm from UIT surface for Custom 465 aged at 950°F – UIT treated

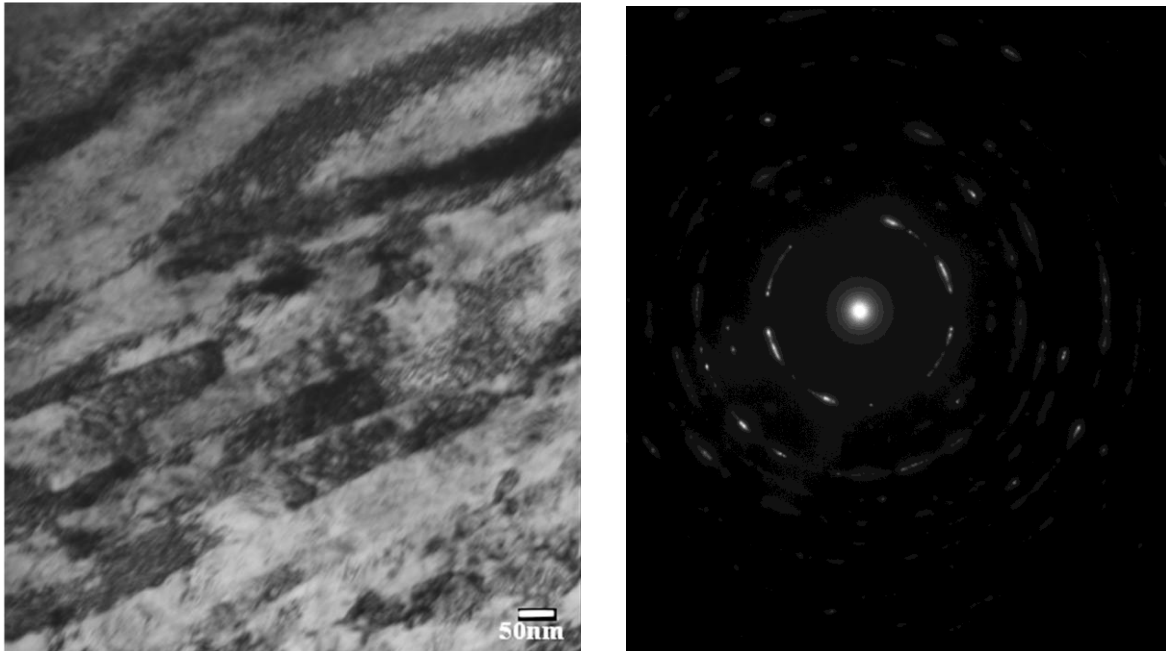

Figure 32: TEM micrographs of sample taken at 1mm from UIT surface for Custom 465 aged at 950°F (a) martensite laths (b) SADP of image in 32(a)

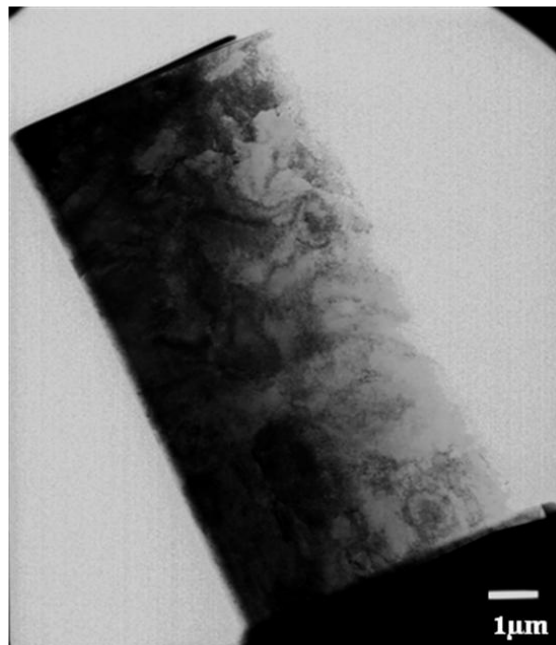

Figure 33: TEM micrographs of sample taken at 6mm from UIT surface for Custom 465 aged at 950°F

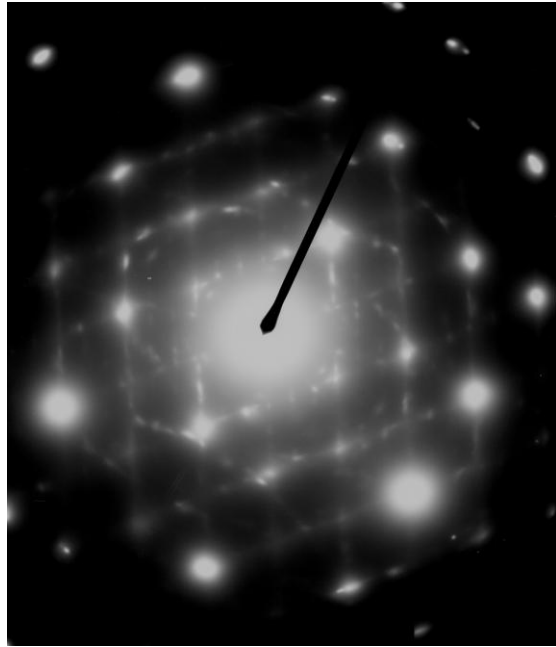
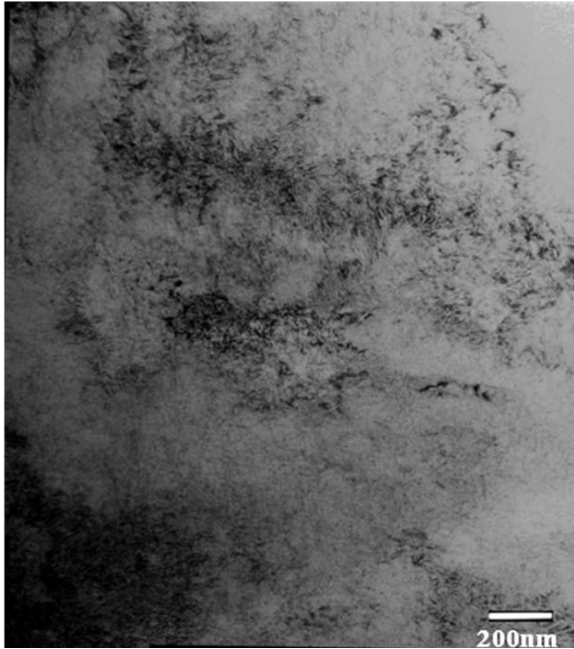

Figure 34: TEM micrograph and SADP of sample taken at 6mm from UIT surface for Custom 465 aged at 950°F

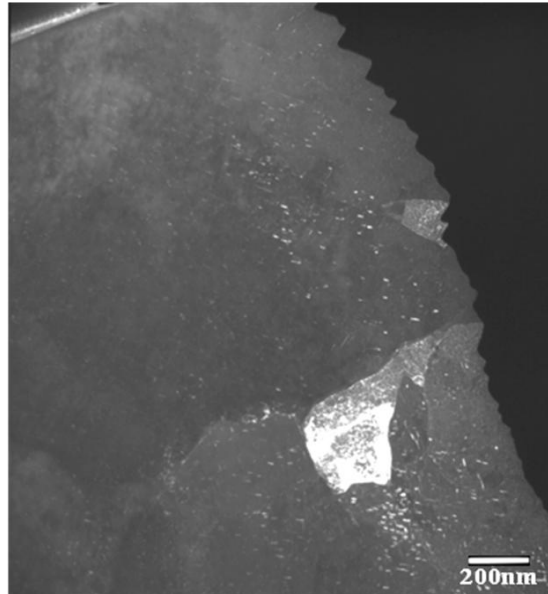
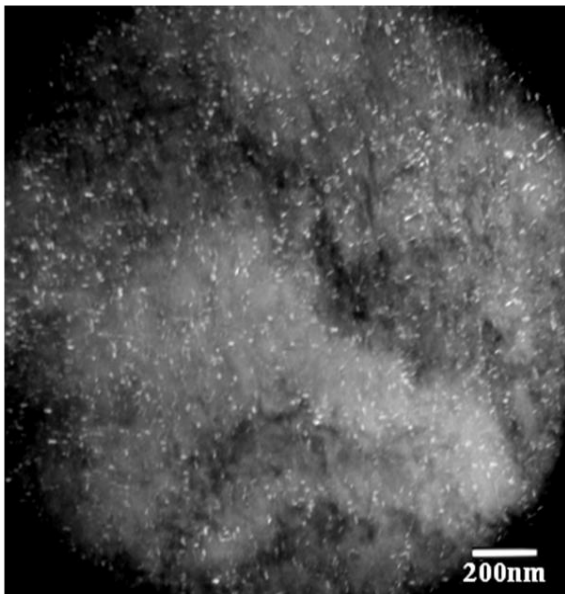

Figure 35: TEM image of precipitates in sample taken at 6mm from UIT surface for Custom 465 aged at 950°F – UIT treated

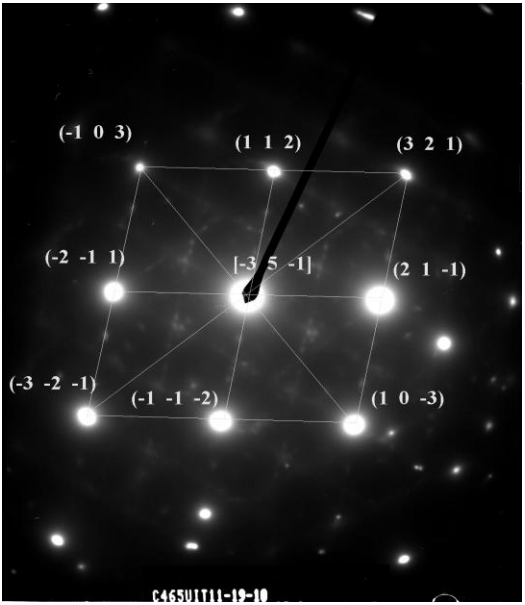
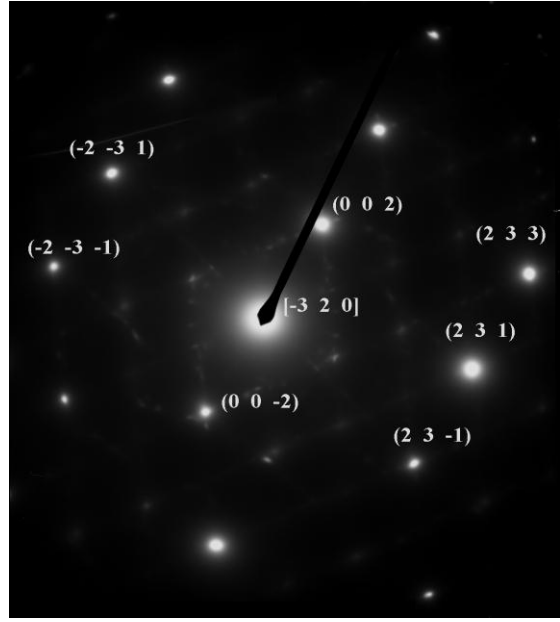
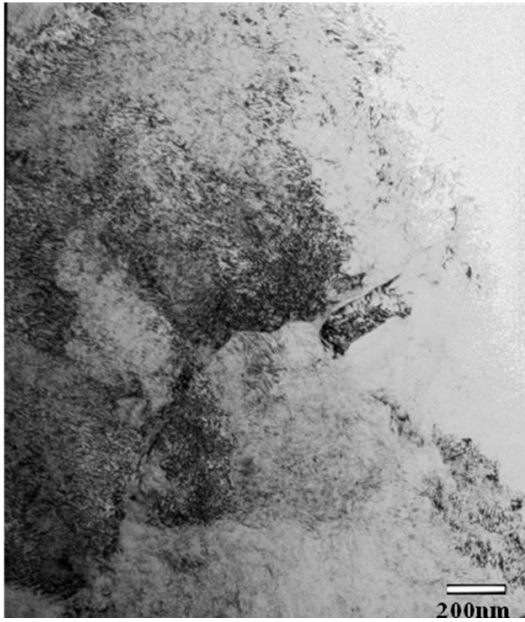

Figure 36: (a) TEM micrograph of sample taken at 6mm from UIT surface for Custom 465 aged at 950°F (b) &(c) SADP of image in figure 35 and 36a (d) Micro diffraction of image in figure 35b – UIT treated

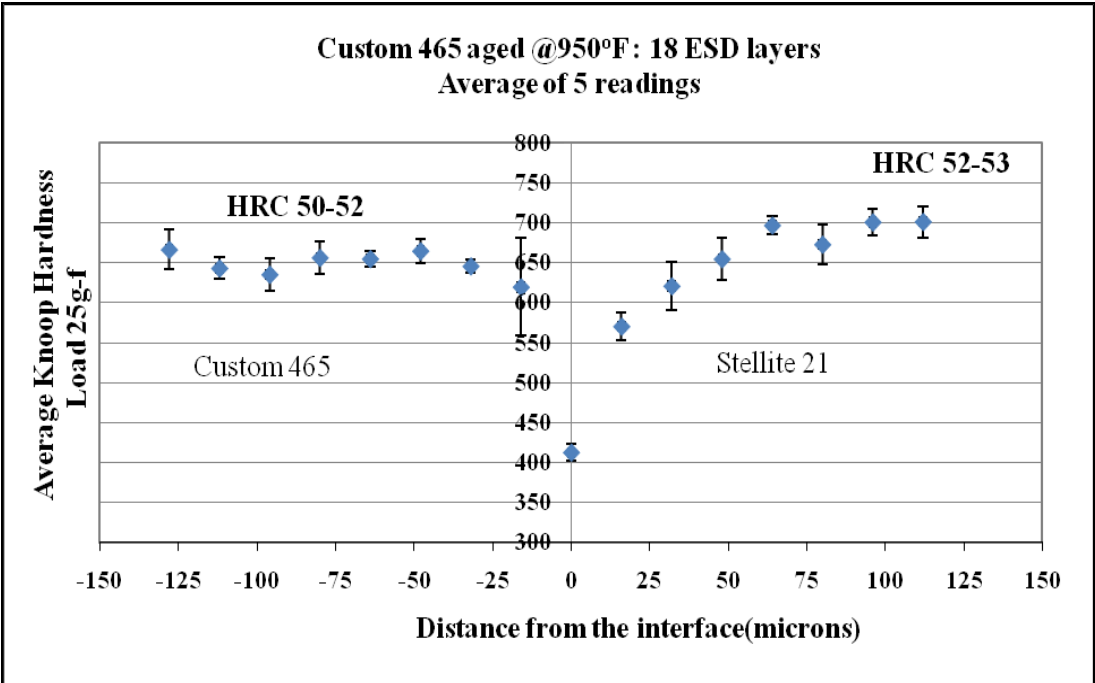

Figure 37. Hardness profile for ESD of Stellite 21 on aged Custom 465 alloy

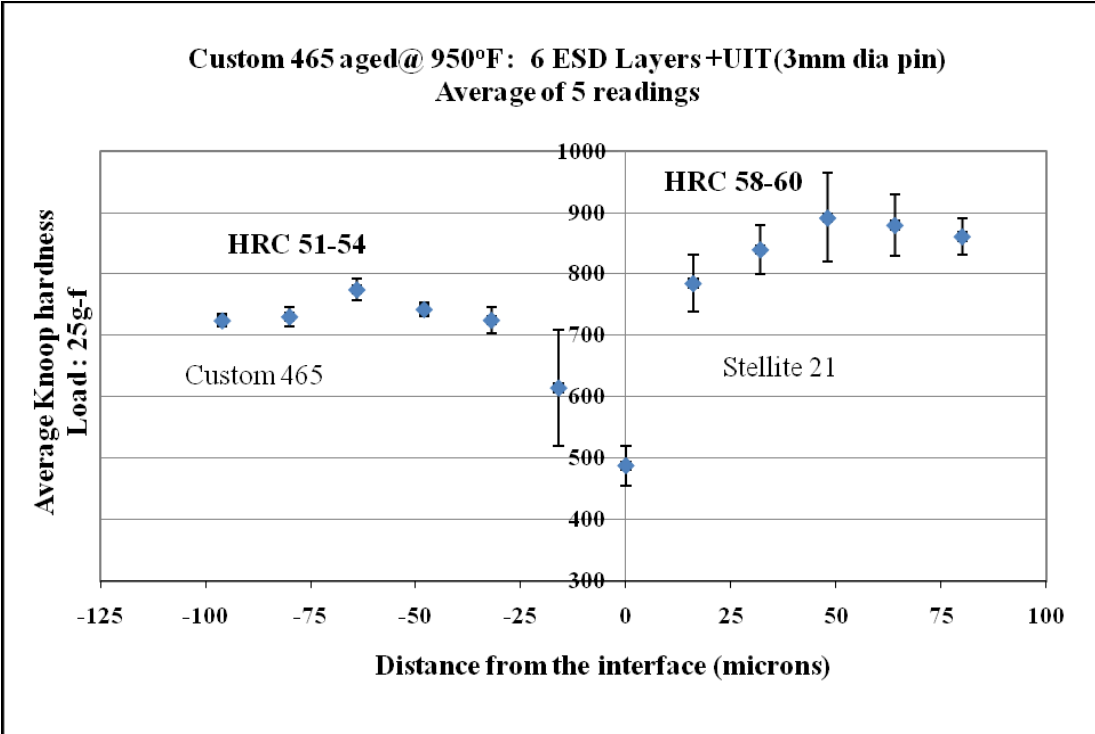

Figure.38. Application of UIT after ESD of stellite 21 on aged Custom 465 alloy

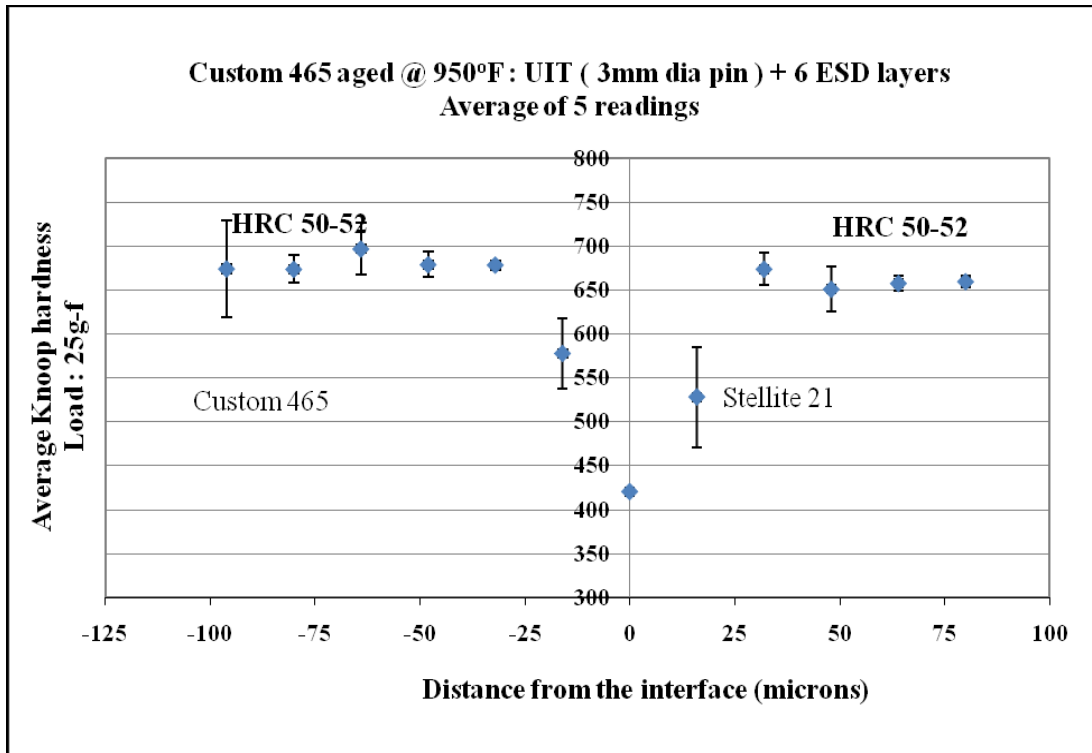

Figure.39. ESD of stellite 21 on UIT treated Custom 465 alloy

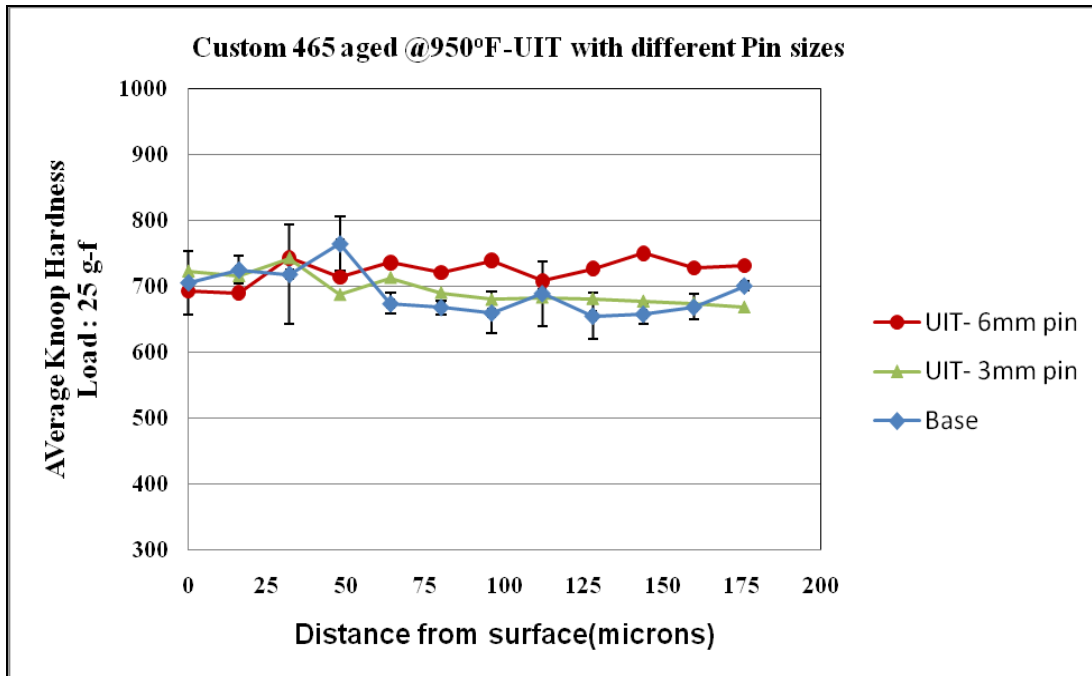

Figure.40. Hardness depth profile for aged C465 alloy treated with two UIT pin sizes

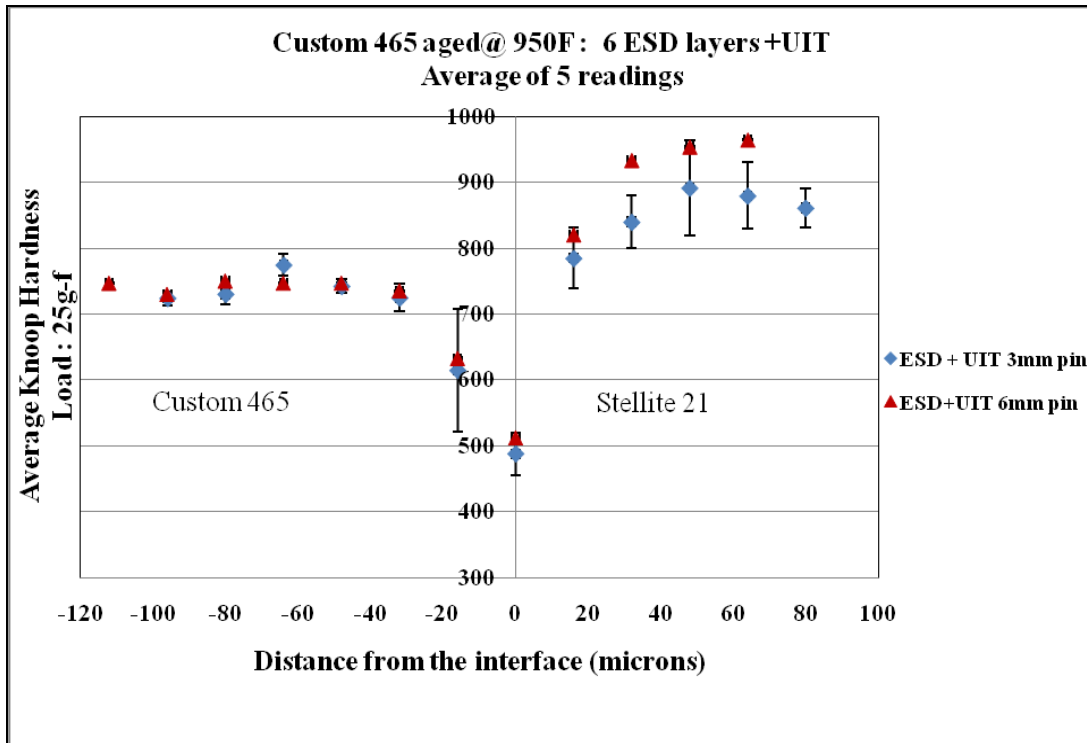

Figure.41. Hardness depth profile for ESD+UIT on C465 aged @ 950°F with two UIT pin sizes

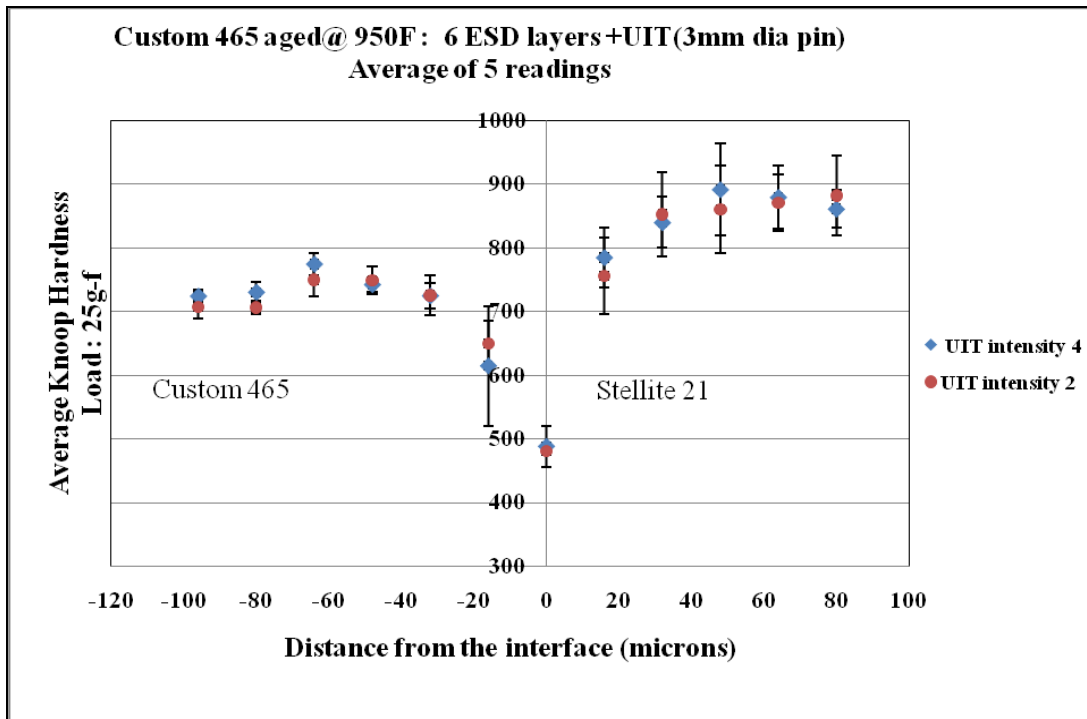
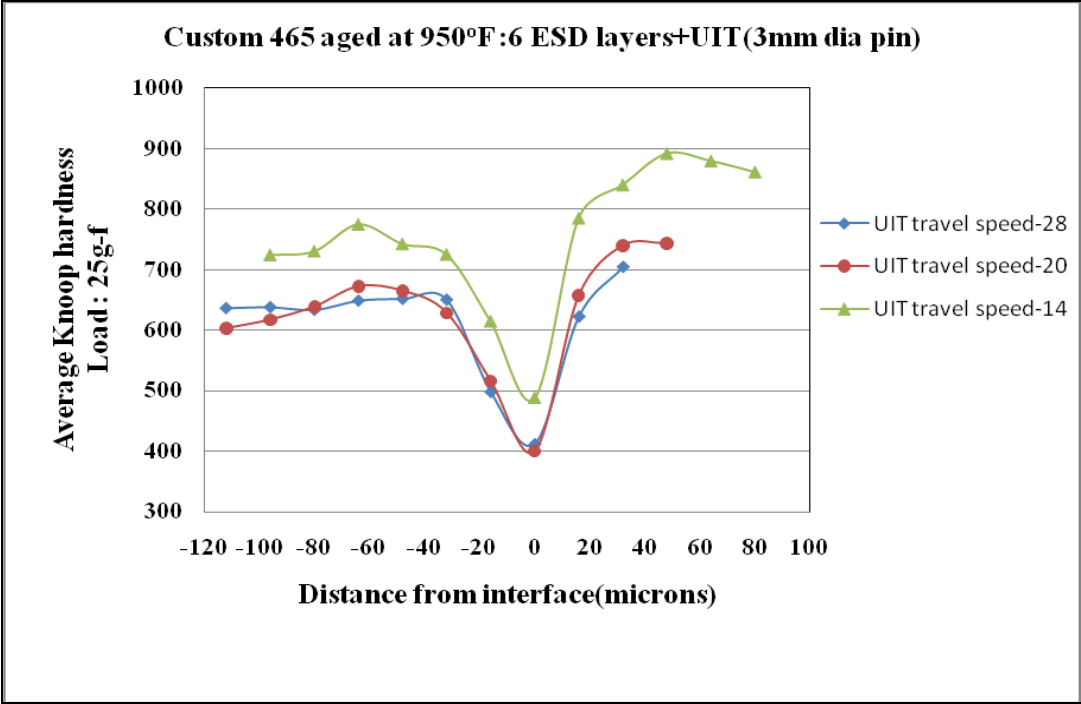
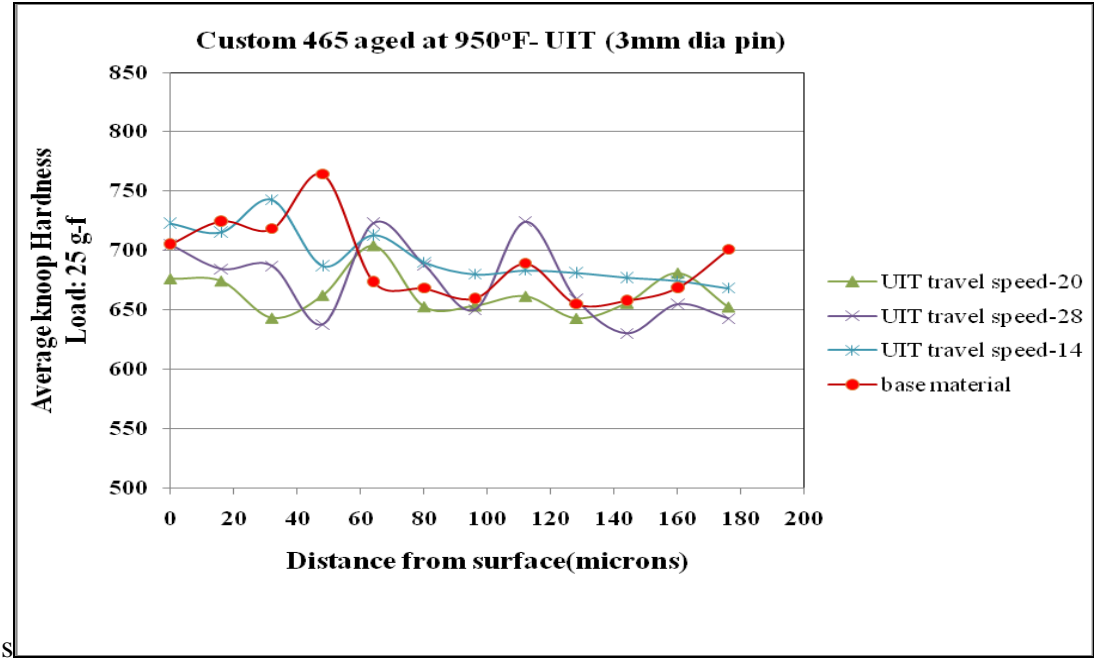

Figure.42. Hardness depth profile for aged C465 alloy with 2 UIT intensities



Note: travel speed number 14 corresponds to 0.12 in/sec, 20 (0.34in/sec), 28 (0.57in/sec)

Figure.43. Hardness depth profile for ESD with UIT travel speed numbers 14,20,& 28 on Custom 465



Note: travel speed number 14 corresponds to 0.12 in/sec, 20 (0.34in/sec), 28 (0.57in/sec)

Figure.44. Hardness depth profile comparison for UIT treated surface with UIT travel speed numbers 14, 20 & 28

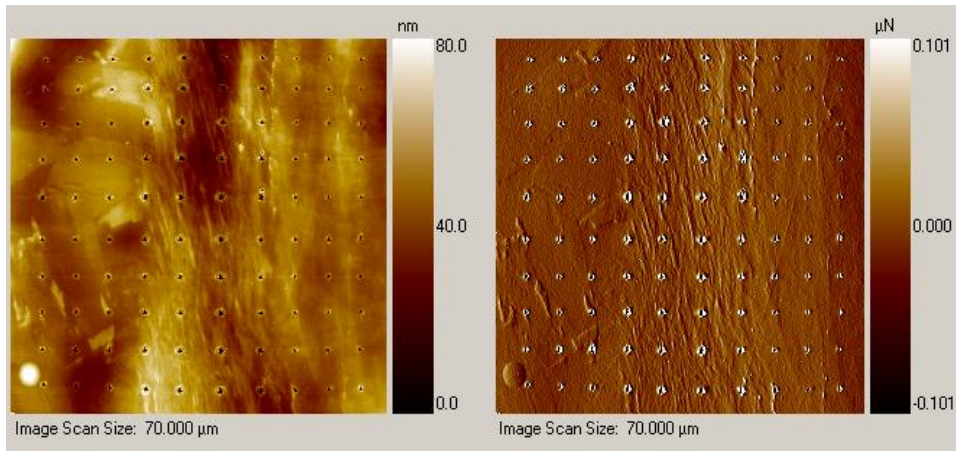

Figure 45 (a) Topographical image and (b) gradient SPM image showing indent array.

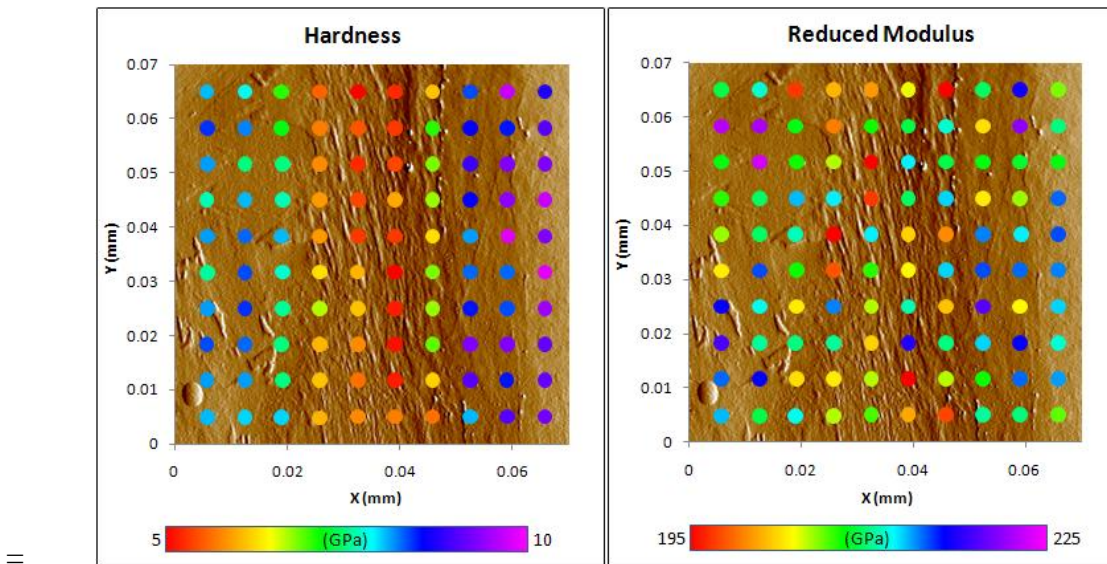

Figure 45. (c)Color maps of the hardness and (d)modulus SPM image of the test area.

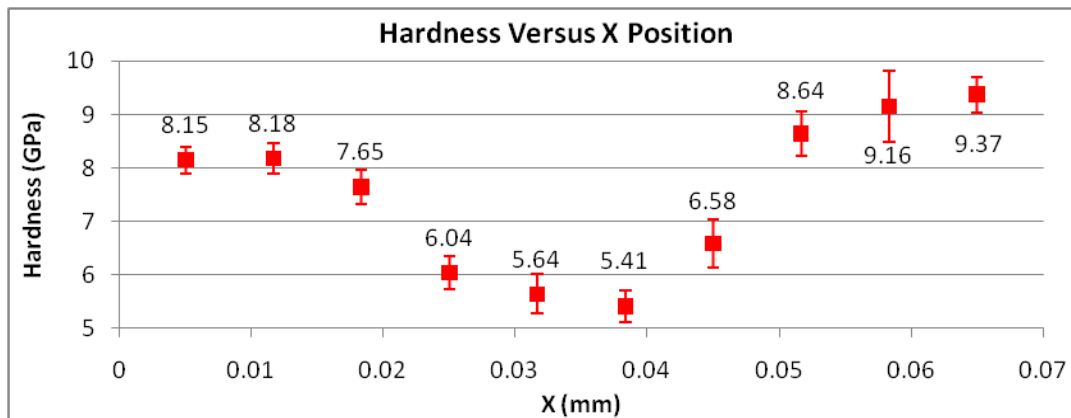

Figure 46 Average hardness of each column of indents from fig 45b, one std deviation

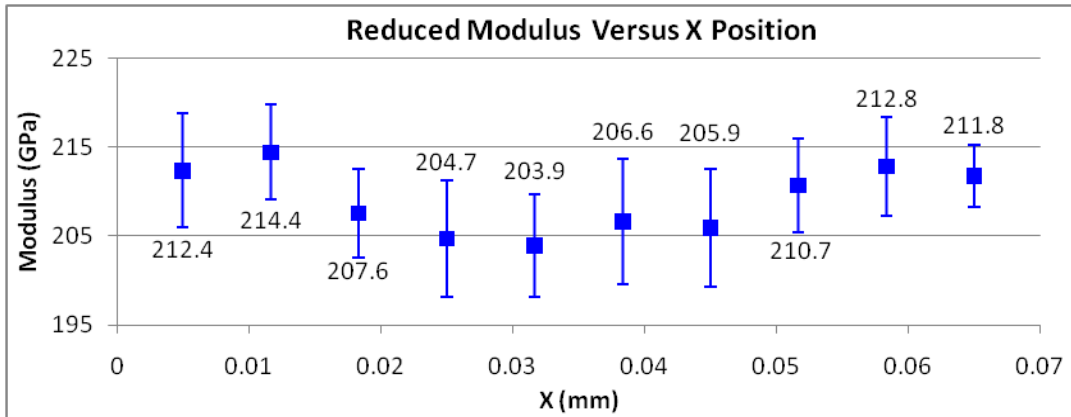
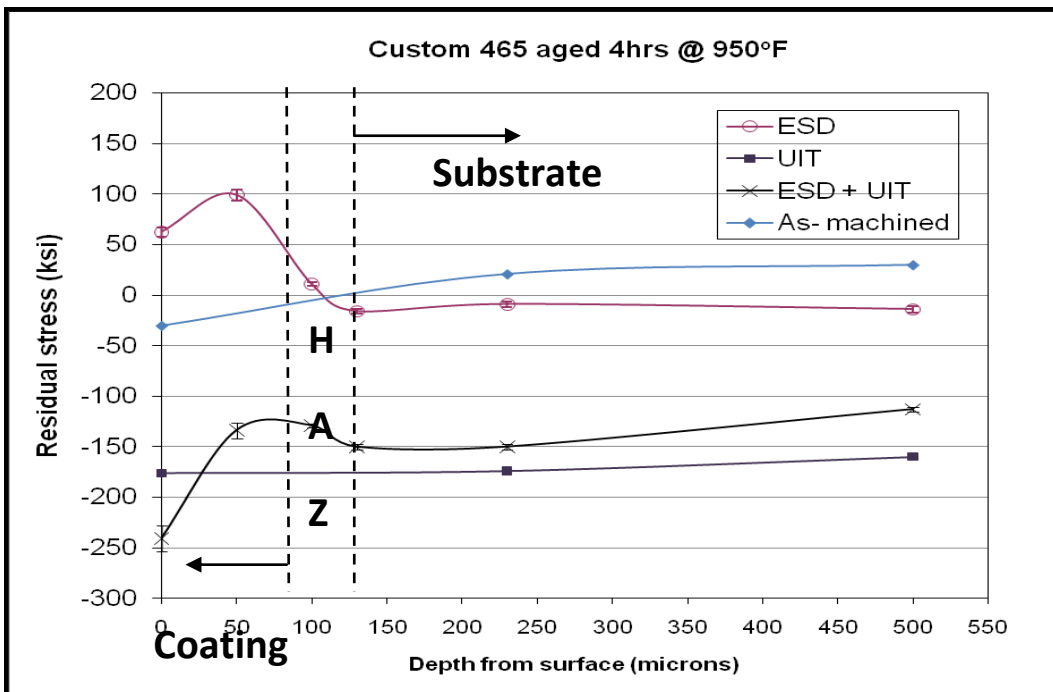

Figure 47. Average modulus of each column of indents from the 10x10 array, error bars represent 1 standard deviation



Note: As-machined specimen has no ESD/UIT treatment applied.

Figure.48. Residual stress depth profile for Custom 465 aged at 950°F

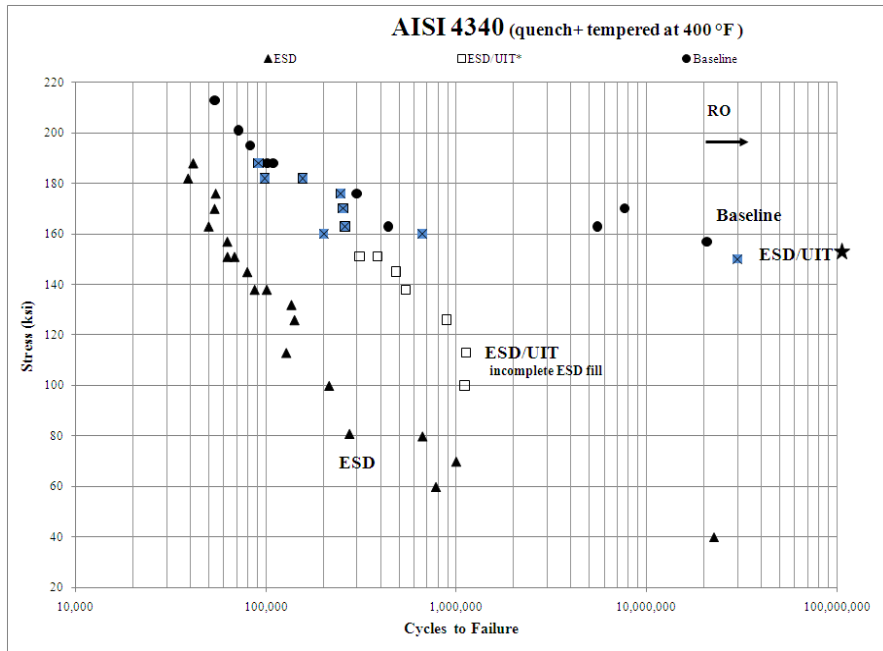

Figure 49 Fully reversed, $R = -1$, fatigue curve for reference 4340 tempered at 400°F. data points only; baseline, ESD, and ESD+UIT conditions. The ESD/UIT★ data are for improved ESD filled divots+UIT.

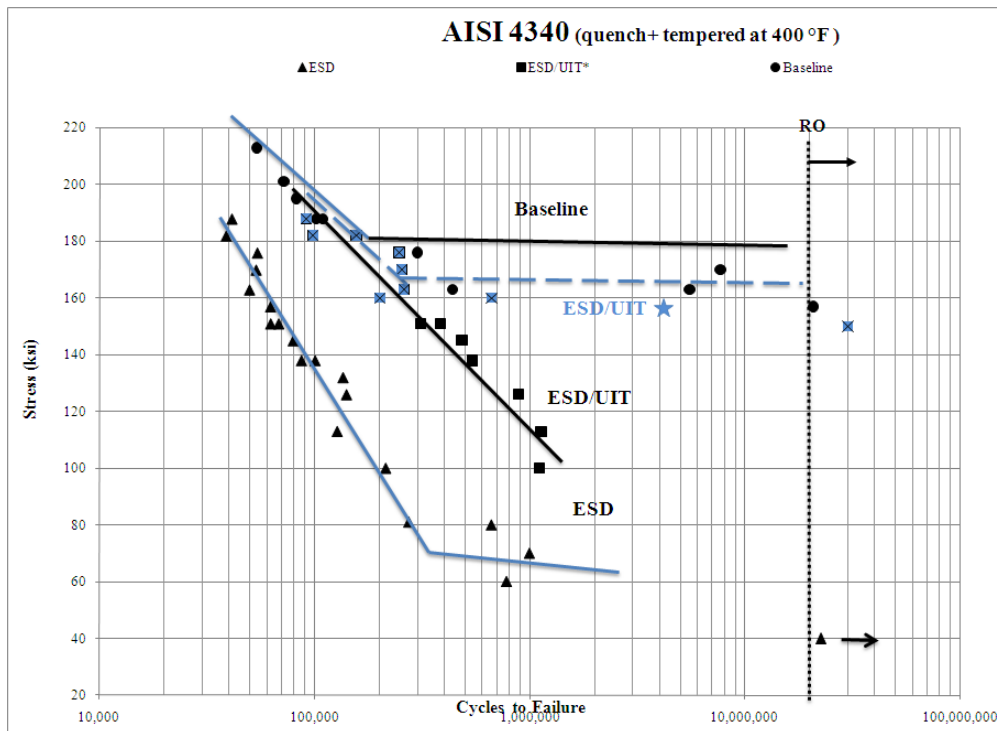

Figure 50. Same as figure 49, Fully reversed, R= -1, fatigue curve for 4340 tempered at 400°F. Baseline , ESD, ESD/UIT (incomplete ESD divot fill) and ESD/UIT★ (improved ESD filled divot) Trend lines added manually.

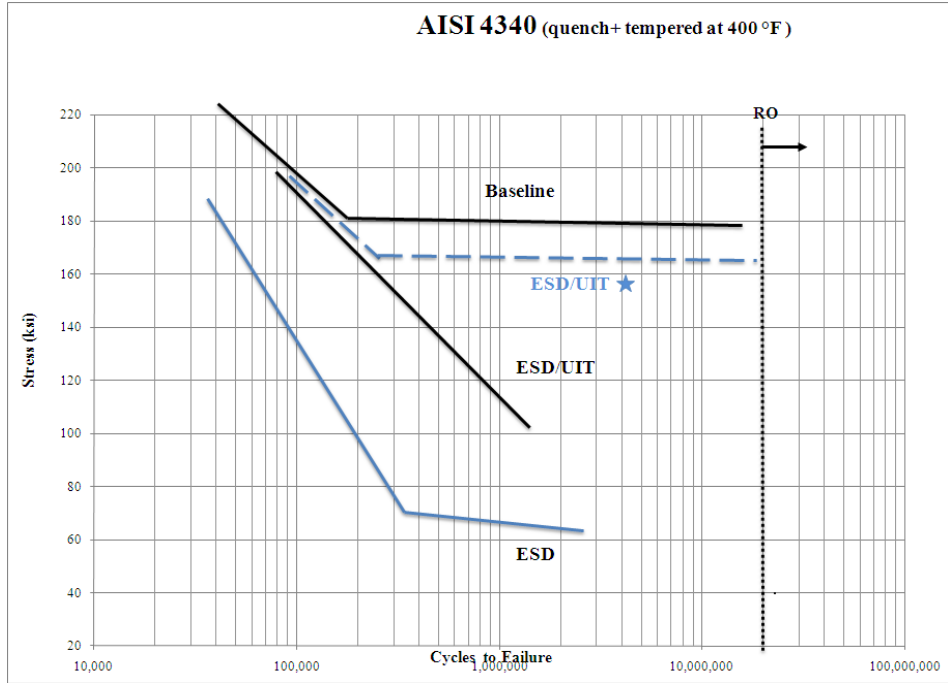

Figure 51. Same as figure 50, data points not shown

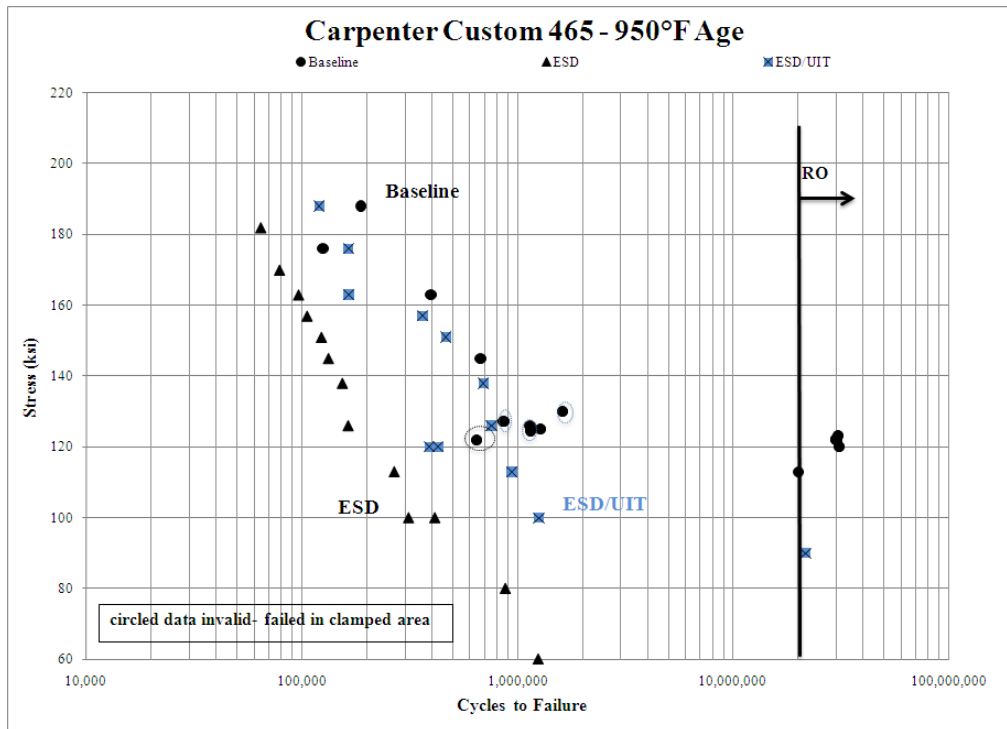

Figure 52. Fully reversed, R= -1, fatigue curve for C465 aged at 950°F; baseline, ESD, and ESD+UIT conditions.

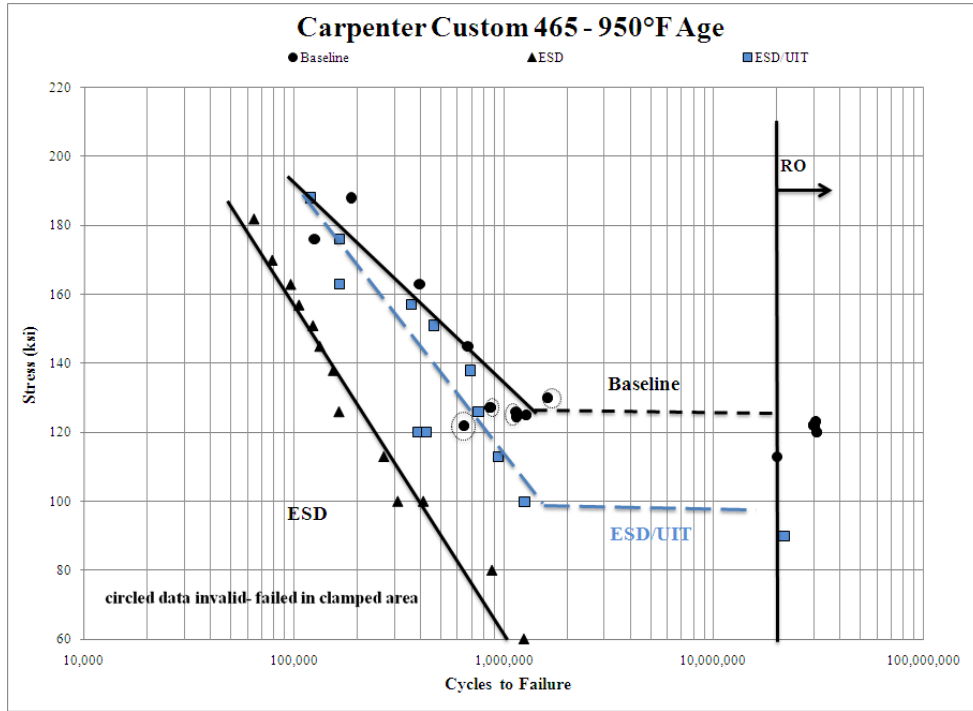

Figure 53 Same as figure 52 but with manually drawn trendlines added, Circled data ignored.

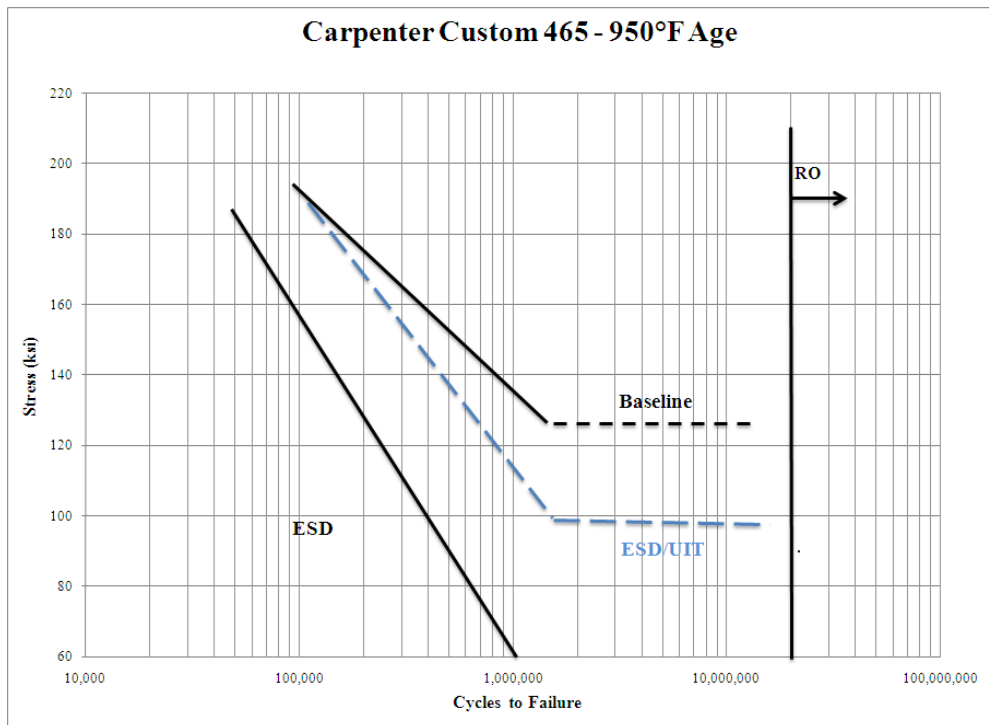

Figure 54 Same as figure 53 but without data points included

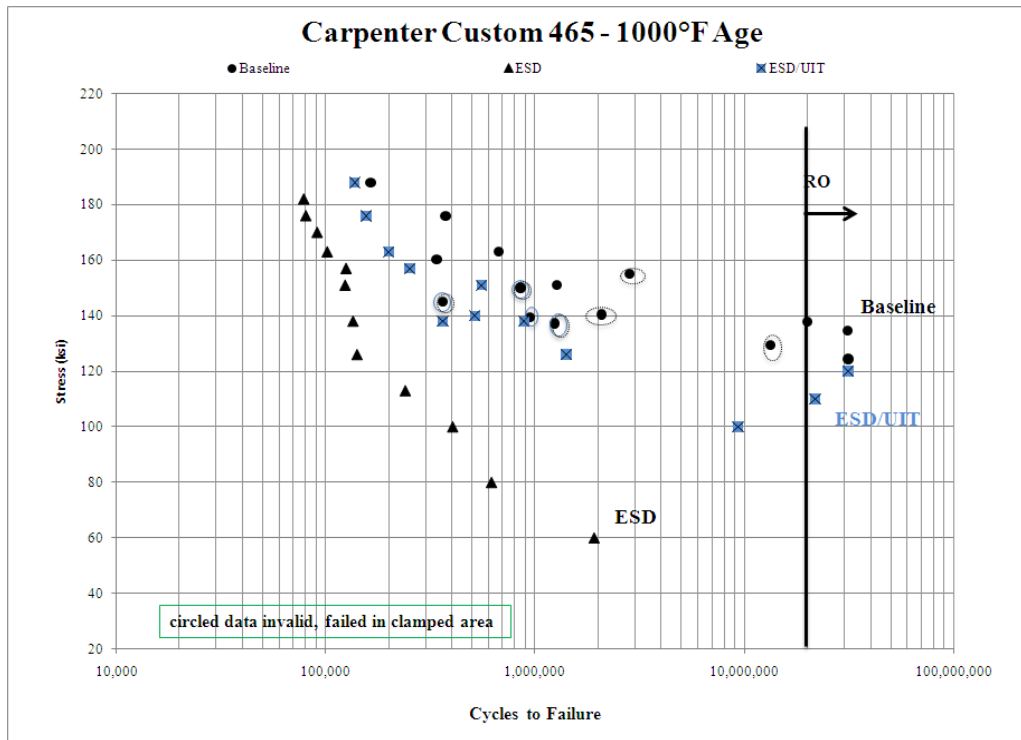

Figure 55 Fully reversed, $R = -1$, fatigue curve for C465 aged at 1000°F ; baseline, ESD, and ESD+UIT conditions.

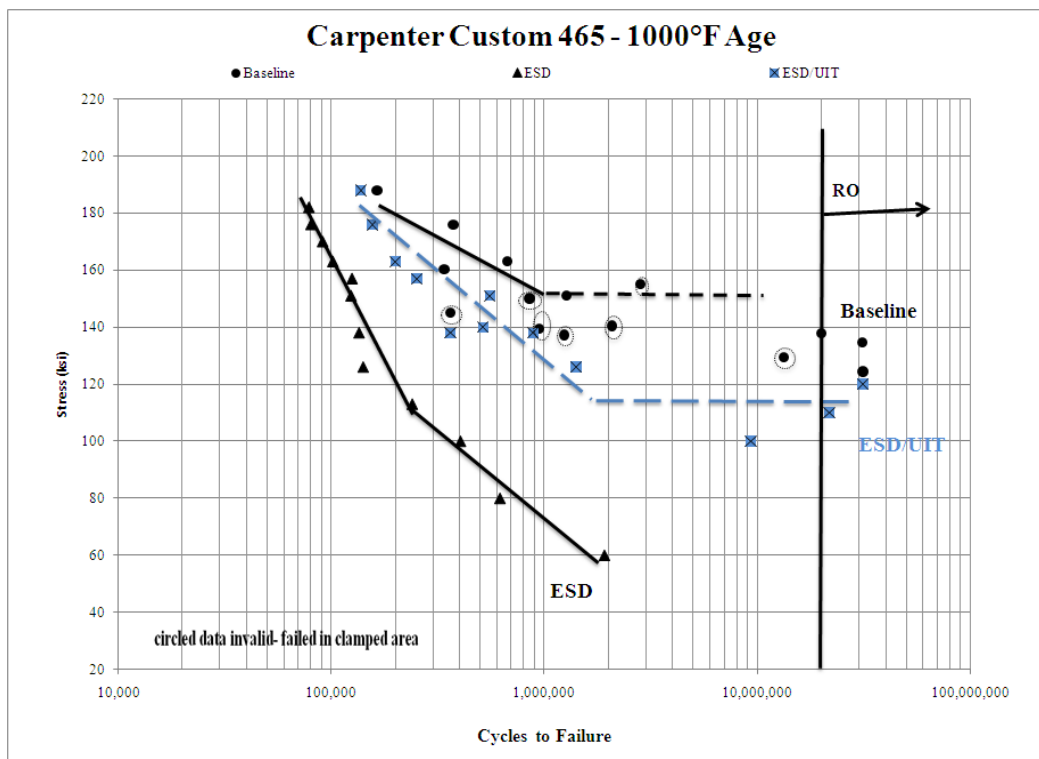

Figure 56 Fully reversed, R= -1, fatigue curve for C465 aged at 1000°F; baseline, ESD and ESD+UIT, manual trend lines added.

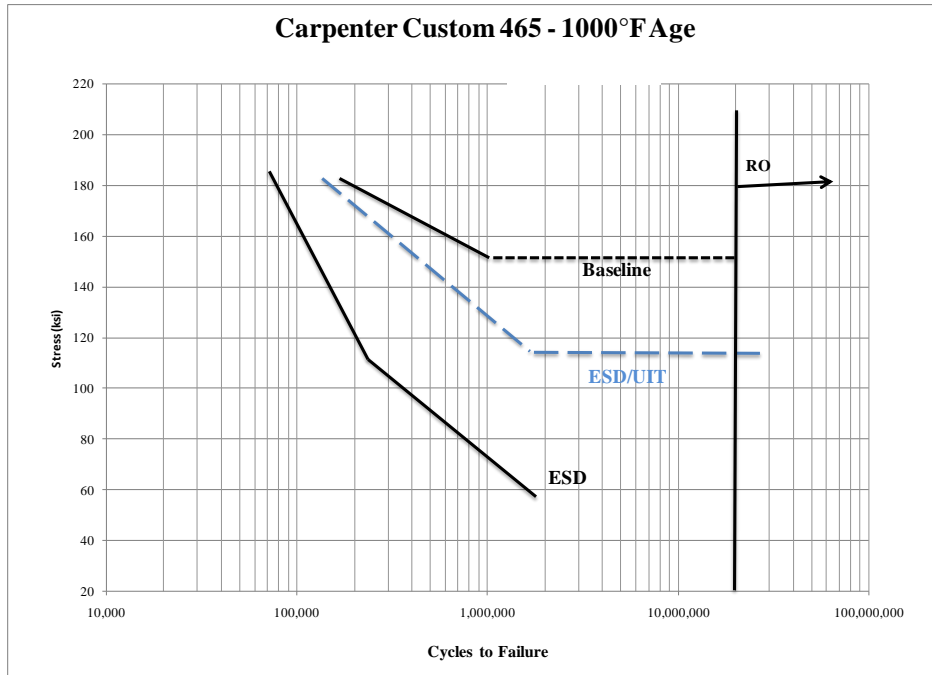

Figure 57 Same as figure 56 but with only trend lines shown

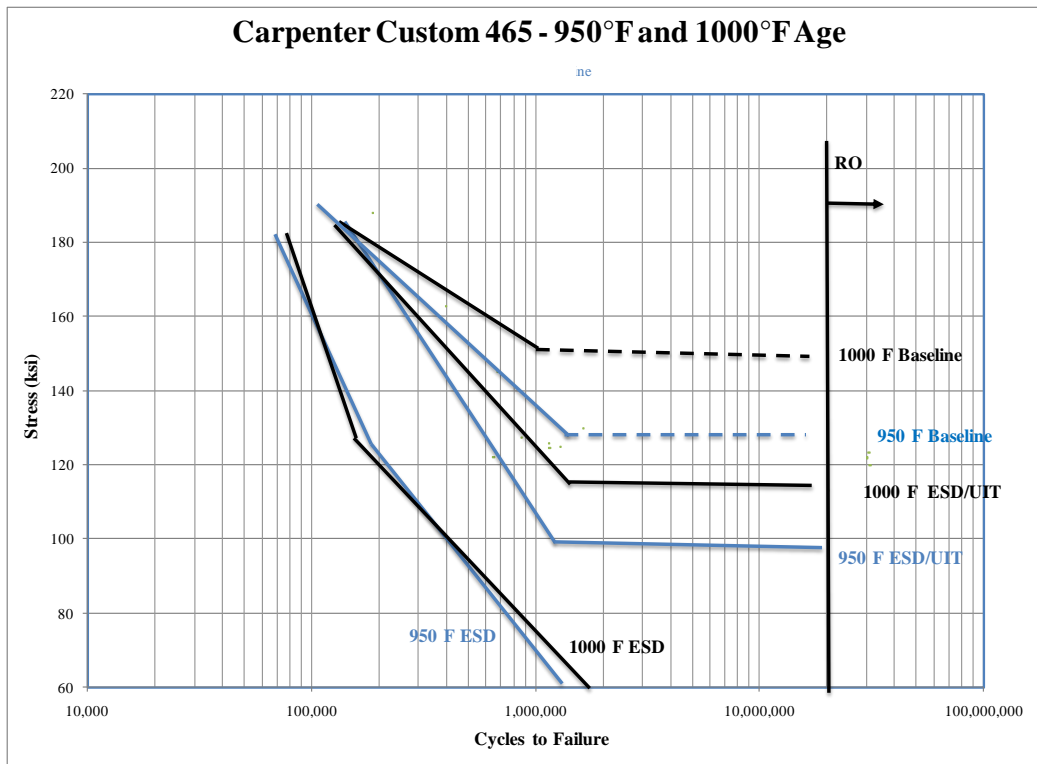

Figure 58 Fully reversed, R= -1, fatigue curve for C465 aged at 950°F and at 1000°F; baseline, ESD and ESD+UIT, trend lines drawn manually

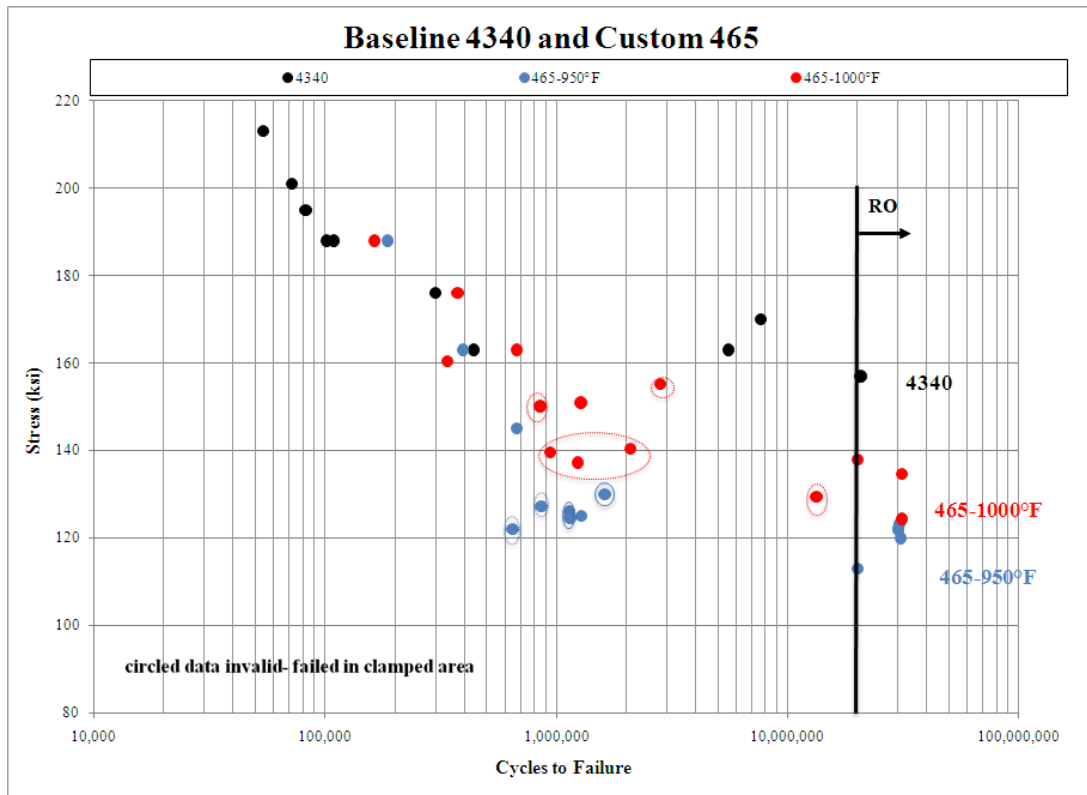

Figure 59 Fully reversed, R= -1, base line fatigue curve for each alloy

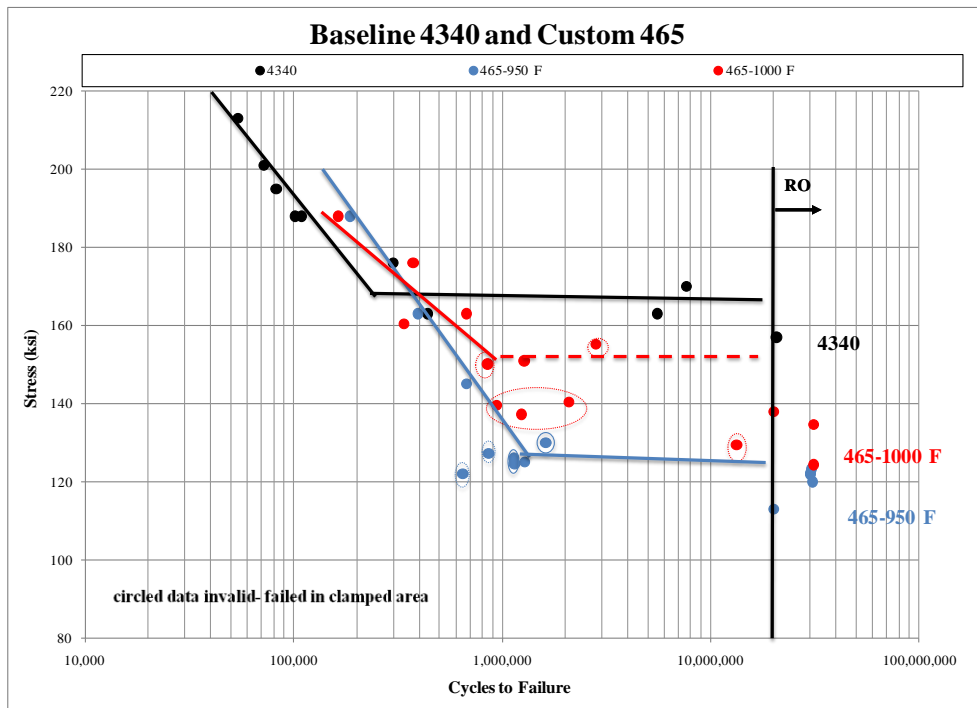

Figure 60 Same as figure 59 with manual trend lines added

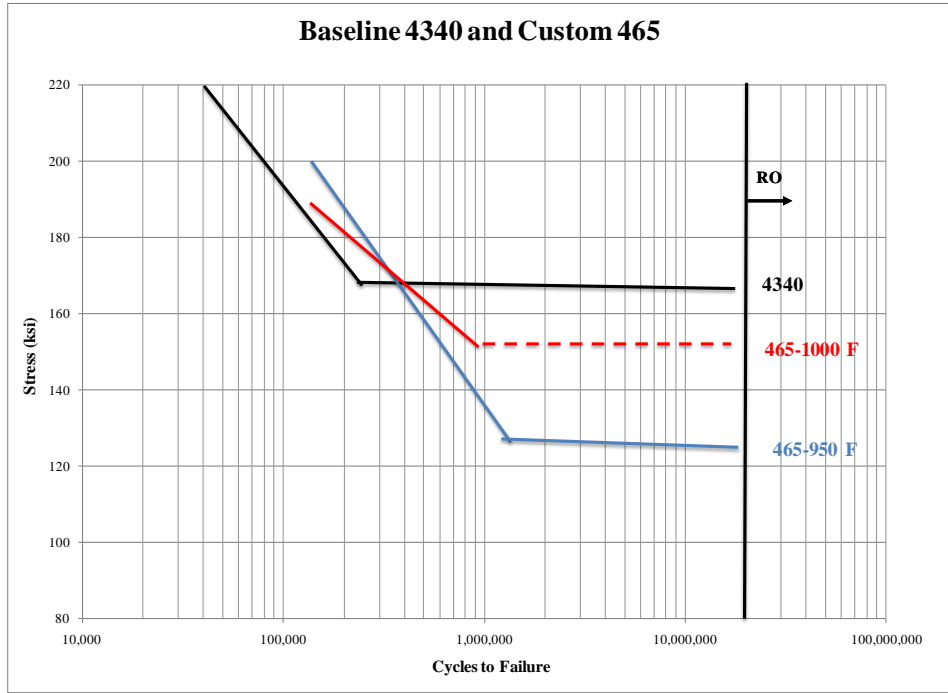

Figure 61 Same as figure 60 with only trend lines shown



Figure 62 UIT treatment on both sample sides at radius to clamped wide shoulder



Figure 63 4340 baseline fatigue sample, 200ksi max stress, 72,000 cycle life

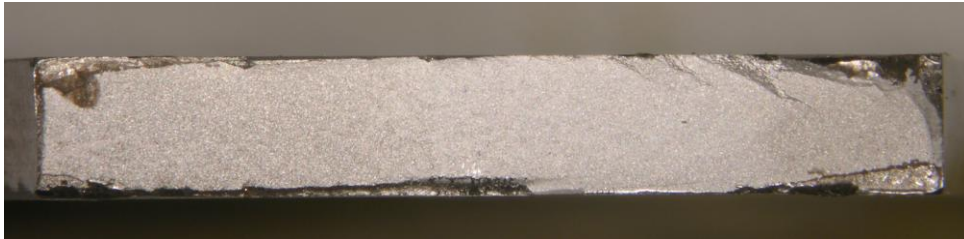

Figure 64 4340 baseline fatigue sample, 176ksi max stress, 300,000 cycle life

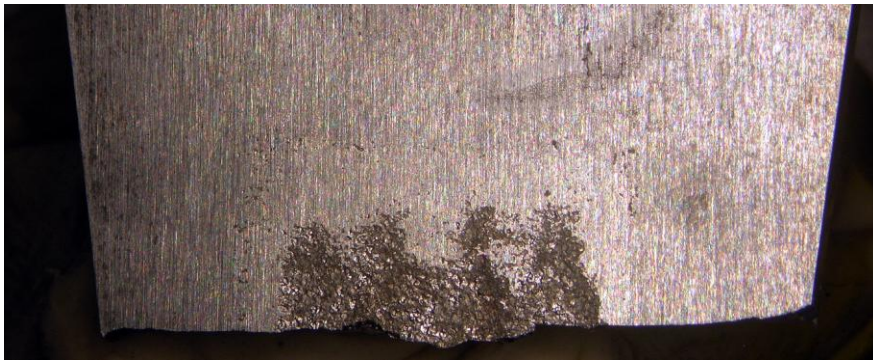

Figure 65 4340 +ESD fatigue, top view, failed through incompletely filled ESD

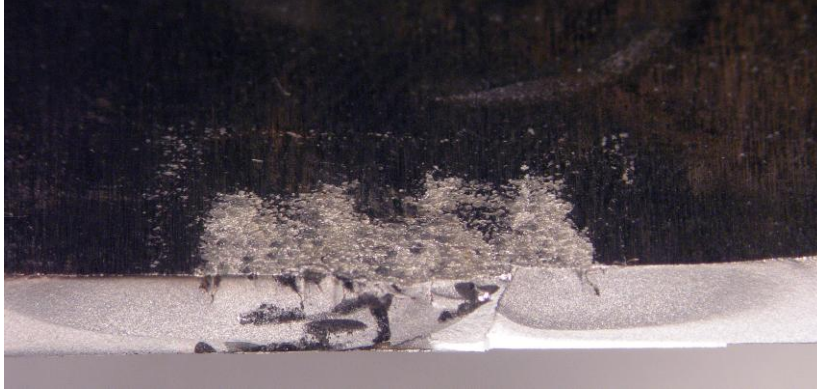

Figure 66 4340+ESD enlarged view of previous image showing multiple fatigue initiation sites from ESD deposit



Figure 67 4340 +ESD top view, ESD as deposited and underfilled



Figure 68 4340+ESD, top surface surface ground after ESD; ESD fill incomplete

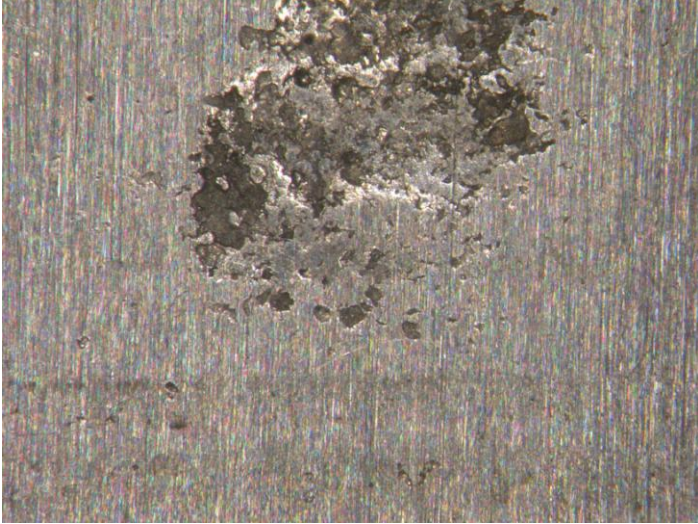

Figure 69 4340+ESD+UIT, surface ground after UIT, incomplete ESD fill area



Figure 70 4340+ESD+UIT, surface ground after UIT revealing incomplete ESD fill areas

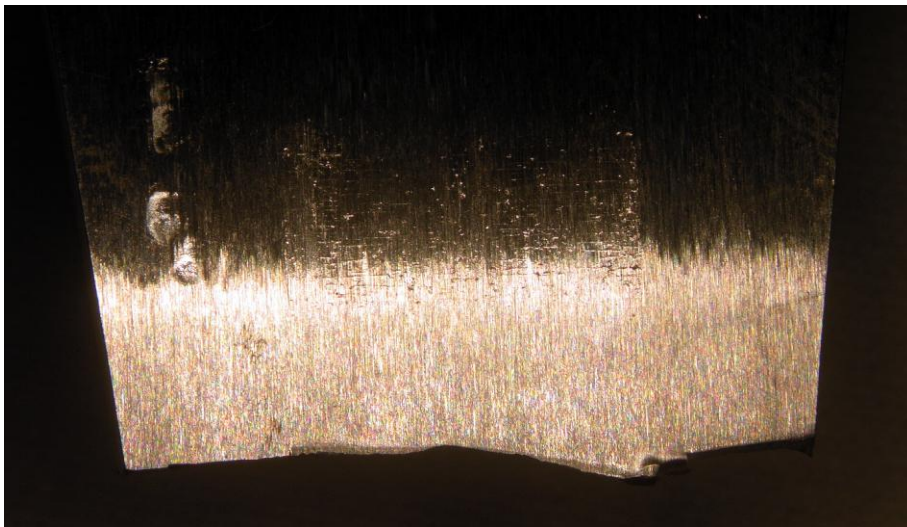

Figure 71 4340+ESD+UIT, top view, failed outside of ESD+UIT area(top center)

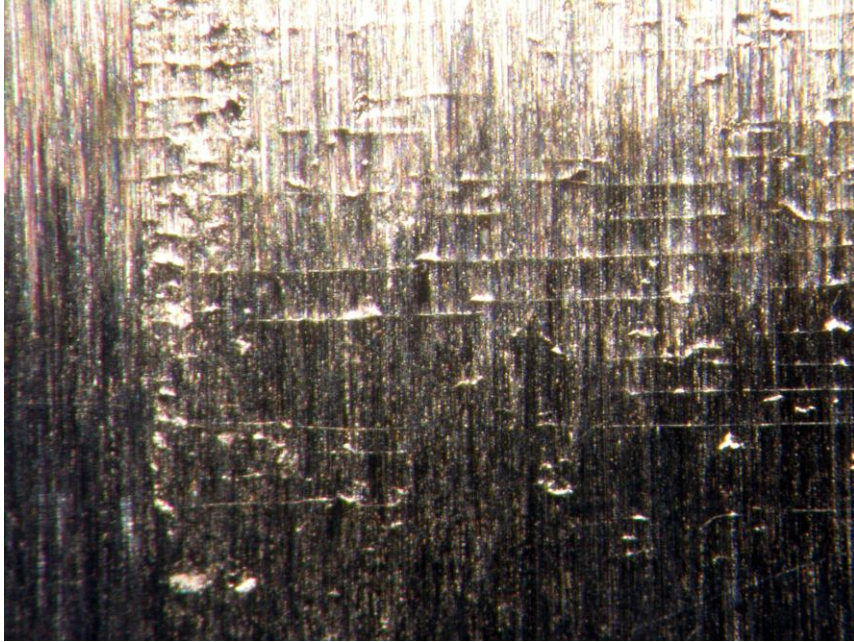

Figure 72 enlarged view of previous figure showing non propagating cracks in ESD+UIT deposit, fracture surface below bottom edge of field of view

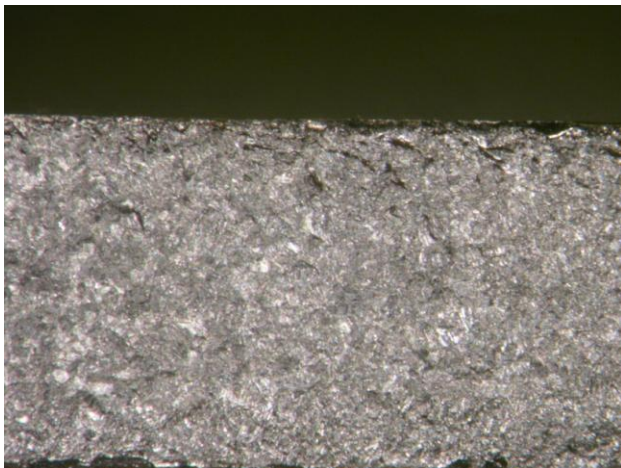

Figure 73 C465 aged at 1000°F, baseline fatigue fracture surface showing much coarser grain size than 4340 and evidence of subsurface cracking

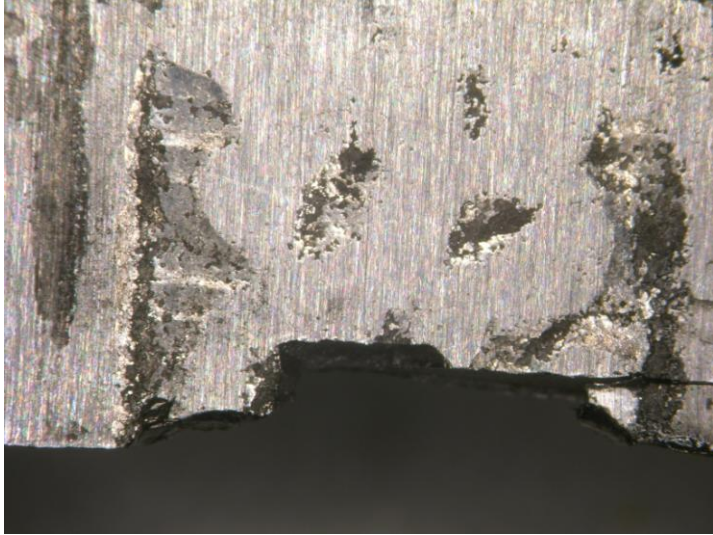

Figure 74 C465 aged at 1000°F, ESD+UIT, top view showing incomplete ESD fill after surface grinding flush with base sample. Cracking started at left, right, and middle incomplete fill areas



Figure 75 C465 aged at 950°F, ESD, fatigue fracture surface showing multiple crack initiation from ESD treated surface

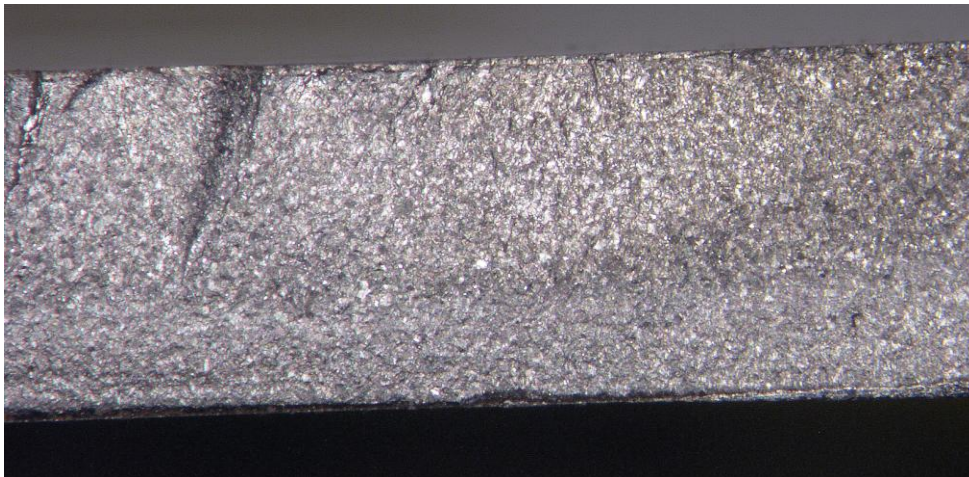

Figure 76 Enlarged view of previous figure showing coarse grain size and cracks initiating from top ESD surface

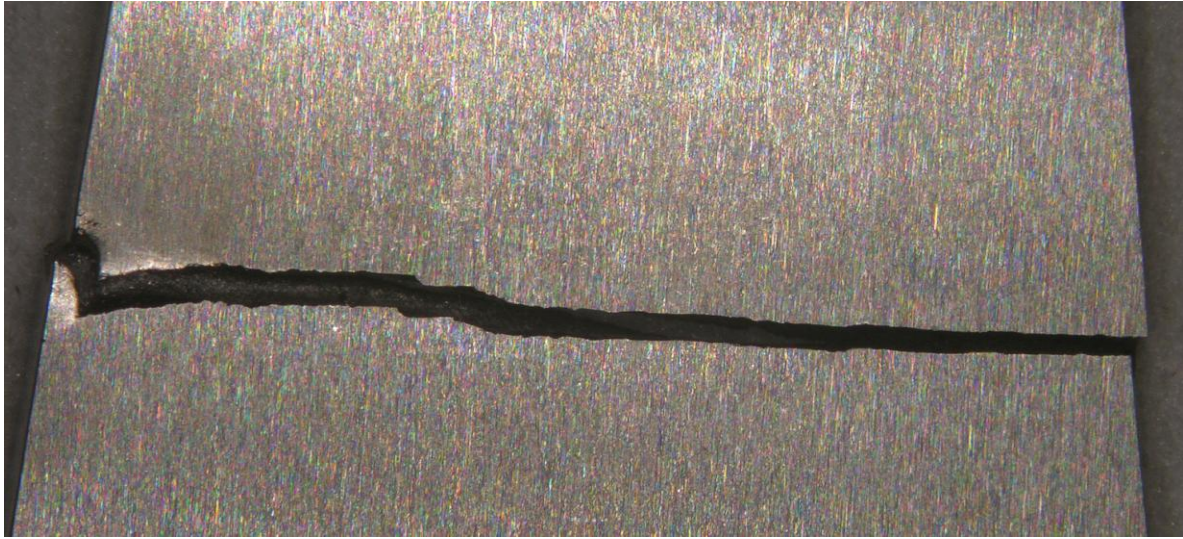

Figure 77 C465 aged at 950°F, ESD + surface ground complete ESD fill, fracture occurred through the middle of the ESD deposit

APPENDIX- I: Additional figures for C465 aged at 1000°F, 300M tempered at 400°F and at 575°F, and Ferrium S53

List of figures

78. Custom 465 aged @ 1000F, 9 ESD Layers
79. Knoop microhardness profile (25g-f load) Custom 465 aged @ 1000F -9 ESD layers
80. ESD of Stellite 21 on C465 aged @ 1000F (a) With UIT (b) Without UIT
81. Hardness profile for ESD of Stellite 21 on aged Custom 465 alloy
82. Application of UIT after ESD of stellite 21 on aged Custom 465 alloy
83. ESD of stellite 21 on UIT treated Custom 465 alloy aged @ 1000F
84. Hardness depth profile for ESD +UIT on aged C465 alloy with two UIT pin sizes
85. Hardness depth profile for UIT on aged C465 alloy treated with two UIT pin sizes
86. SEM cross section image for C465 aged @ 1000F- 200X
87. SEM cross section image for C465 aged @ 1000F- 2500X
88. SEM cross section image of C465 aged @ 1000F with Ti_xN inclusion
89. EDX map of Inclusion in C465 aged @ 1000F and inclusion Elemental Composition
90. EDX spectrum compositions and map of Custom 465 aged @ 1000F
91. TEM image of precipitates in Custom 465 substrate aged at 1000°F (a) Bright field image
(b) Dark field image – no ESD/UIT treatment
92. SADP of bright field image in figure 60
93. Bright field and dark field TEM images showing precipitates in Custom 465 substrate aged at 1000°F –no ESD/UIT treatment
94. Low magnification TEM image showing fine grains in the ESD treated substrate
95. TEM micrograph and SAD pattern of Custom 465 substrate aged at 1000°F- ESD
96. TEM micrograph and SAD pattern of HAZ in Custom 465 aged at 1000°F- ESD
97. TEM micrograph and SAD pattern of mixing layers (1st & 2nd ESD layers) -ESD
98. TEM micrograph and SAD pattern of mixing layers (1st & 2nd ESD layers) -ESD
99. TEM micrograph and SAD pattern of Top ESD layers-ESD treated
100. Back Scatterd SEM microgarph of Custom 465 aged at 1000°F showing compositional change at the HAZ interface- ESD+UIT treated
101. Lath structure in Custom 465 alloy aged at 1000°F- ESD+UIT treated
102. TEM micrograph and micro diffraction pattern for Custom 465 aged at 1000°F –ESD+UIT treated
103. TEM micrograph and micro diffraction pattern of Custom 465 aged at 1000°F –ESD+UIT treated
104. TEM micrograph of UIT treated stellite 21- ESD+UIT treated
105. TEM micrograph and SAD pattern of HAZ Custom 465 aged at 1000°F –ESD+UIT treated
106. (a) 300M as Quenched- 18 ESD layers (b) 300M tempered @ 400F- 6 ESD layers
107. Microhardness profile for 300M tempered @ 400F -12 ESD Layers

108. Hardness profile for ESD of Stellite 21 on as quenched 300M alloy
109. Hardness profile for ESD of Stellite 21 on tempered 300M alloy
110. Application of UIT after ESD of Stellite 21 on tempered 300M alloy
111. ESD of stellite 21 on UIT treated 300M alloy
112. Hardness depth profile for ESD +UIT on tempered 300M alloy with two UIT pin sizes
113. Hardness depth profile for UIT on tempered 300M alloy with two UIT pin sizes
114. SEM Cross section image for 300M tempered @ 400F
115. SEM cross section image for base material 300M tempered @ 400F showing carbide precipitates
116. EDX spectrum composition and map on 300M tempered @ 400F-ESD 12 layers
117. TEM micrograph of carbide precipitates in 300M substrate tempered at 400°F- no ESD/UIT treatment
118. Low magnification TEM image of 300M alloy and martensitic lath structure in the substrate- ESD treated
119. TEM micrograph and SAD pattern of UIT treated stellite 21- ESD+UIT treated
120. TEM micrographs of lath structure in sample taken at 1mm from UIT surface for 300M alloy tempered at 400°F – UIT treated
121. (a) SADP from multiple lath in figure 88 (c) SADP from single dark lath in image (b)- UIT treated
122. TEM micrographs of large lath structure in sample taken at 6mm from UIT surface for 300M alloy tempered at 400°F- UIT treated
123. SADP of image in figure 90 (b) TEM image large inclusion in sample taken at 6mm from UIT surface – UIT treated
124. ESD of Stellite 21 on 300M tempered @ 575°F- 6 ESD layers
125. Knoop microhardness profile(25g-f load) for ESD on 575°F tempered 300M alloy
126. ESD of Stellite 21 on 575°F tempered 300M alloy (a) without UIT (b) with UIT
127. Hardness profile for ESD of Stellite 21 on 300M alloy tempered @ 575°F
128. Application of UIT after ESD of stellite 21 on 575°F tempered 300M alloy
129. ESD of stellite 21 on UIT treated 300M alloy tempered @ 575°F
130. SEM cross section image of ESD of stellite 21 on 575°F tempered 300M alloy
131. SEM cross section image of base material for 575°F tempered 300M alloy
132. SEM cross section image of base material for 575°F tempered 300M alloy showing carbide precipitates-10000X
133. SEM cross section image of base material for 575°F tempered 300M alloy showing carbide precipitates-20000X
134. EDX spectrums and map of ESD on 575°F tempered 300M- 6 ESD layers
135. TEM micrograph of carbide precipitates in 300M substrate tempered at 575°F (a) bright field image (b) dark field image (c) SADP – no ESD/UIT treatment
136. TEM bright field image showing voids in the stellite 21 deposit- ESD treated
137. TEM micrograph of HAZ in 300M tempered at 575°F- ESD treated

138. TEM image of 300M Substrate tempered at 575°F- ESD+UIT treated
139. TEM micrograph of ESD+ UIT treated (a) 300M Substrate (b) Stellite 21 deposit
140. ESD of stellite 21 on aged Ferrium S-53 alloy- 6 ESD layers
141. Knoop microhardness profile(25g-f load) of ESD on aged Ferrium S-53 alloy
142. Hardness profile for ESD of Stellite 21 on aged Ferrium S-53 alloy
143. Application of UIT after ESD of stellite 21 on aged Ferrium S-53 alloy
144. ESD of stellite 21 on UIT treated Ferrium S-53 alloy aged around 900°F
145. Hardness depth profile for ESD +UIT on aged Ferrium S-53 alloy with two UIT pin sizes
146. Hardness depth profile for UIT on aged Ferrium S-53 alloy with two UIT pin sizes
147. SEM cross section image of base material Ferrium S-53 alloy aged around 900°F
148. SEM cross section image of base material Ferrium S-53 alloy aged around 900°F showing carbide precipitates
149. EDX spectrum analysis and maps of ESD on aged Ferrium S-53 alloy- ESD 6 layers
150. TEM micrograph of base material Ferrium S-53 alloy aged around 900°F –no ESD/UIT treatment
151. TEM micrograph of lath boundary in base material Ferrium S-53 alloy aged around 900°F –no ESD/UIT treatment
152. TEM micrograph of carbide precipitates in base material Ferrium S-53 alloy aged around 900°F – no ESD/ UIT treatment
153. TEM micrograph of Ferrium S-53 substrate aged around 900°F – ESD+UIT treated

APPENDIX I – C465 aged at 1000oF, 300M, S53

C465 aged at 1000F

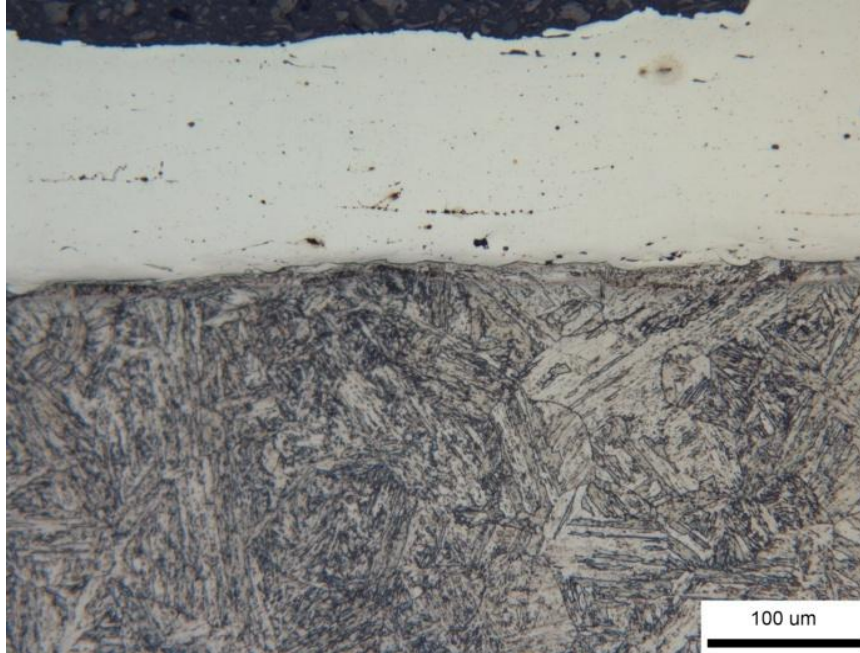

Figure.47. Custom 465 aged @ 1000F, 9 ESD Layers

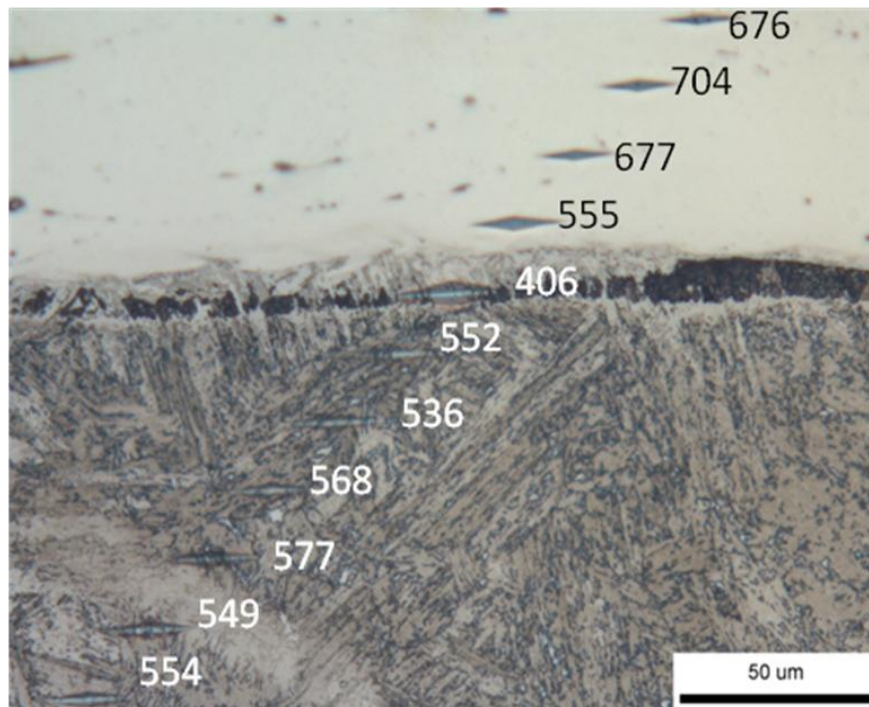

Figure.48.Knoop microhardness profile (25g-f load) Custom 465 aged @ 1000F -9 ESD layers

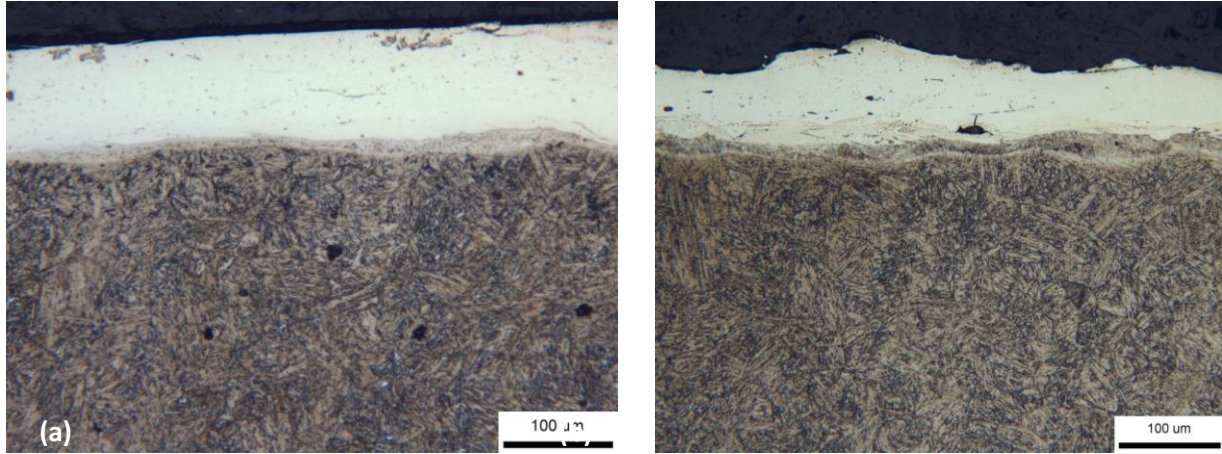

Figure.49. ESD of Stellite 21 on C465 aged @ 1000F (a) With UIT (b) Without UIT

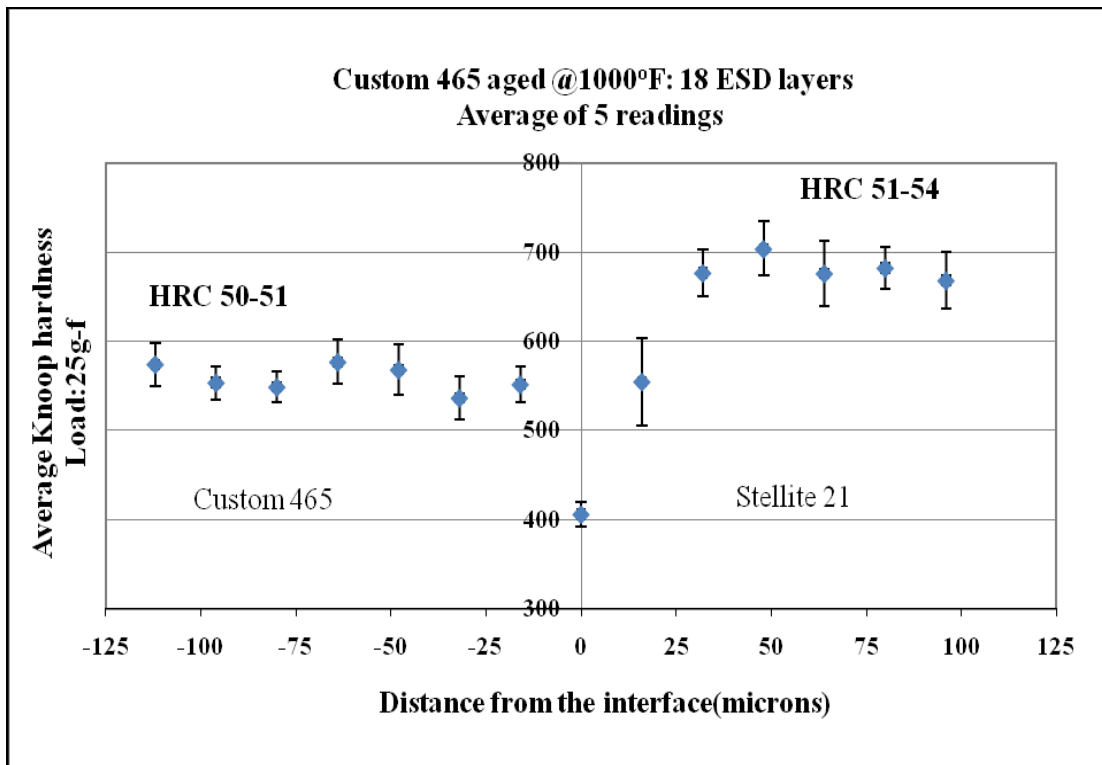

Figure.50. Hardness profile for ESD of Stellite 21 on aged Custom 465 alloy

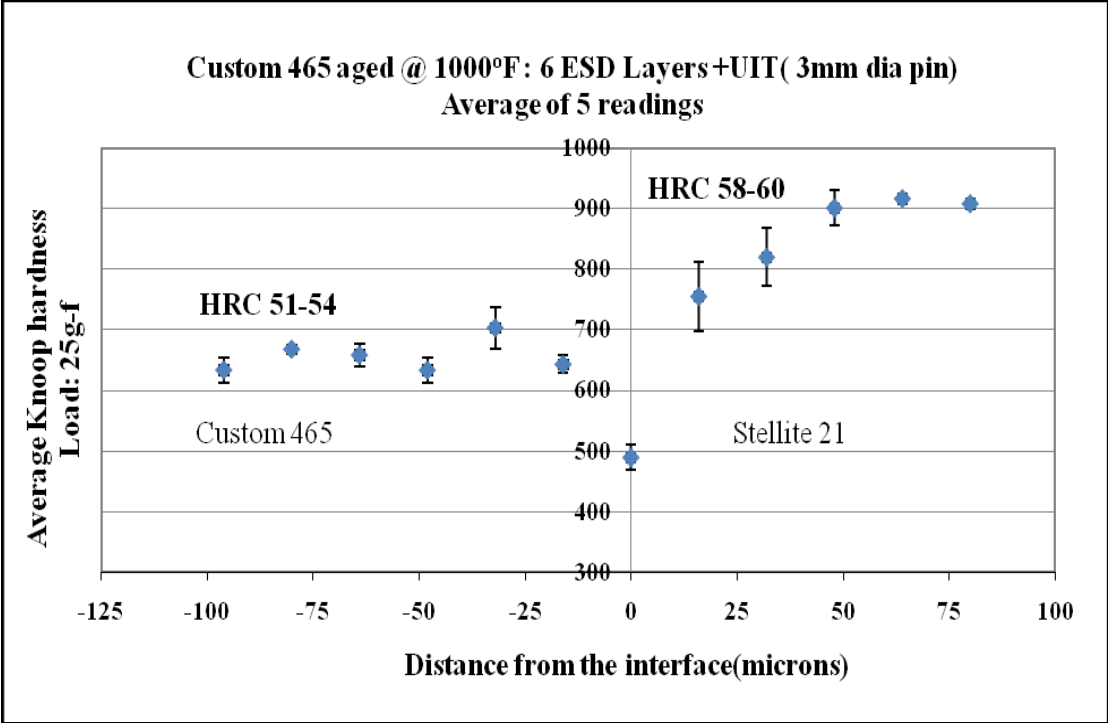

Figure.51. Application of UIT after ESD of stellite 21 on aged Custom 465 alloy

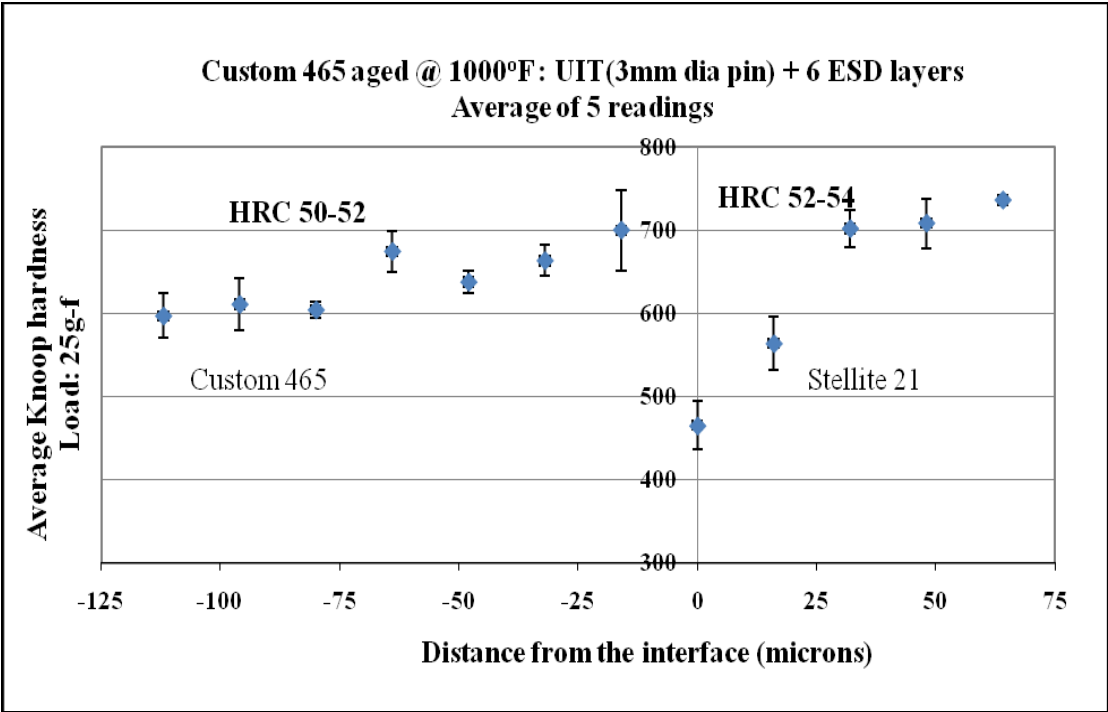

Figure.52. ESD of stellite 21 on UIT treated Custom 465 alloy aged @ 1000F

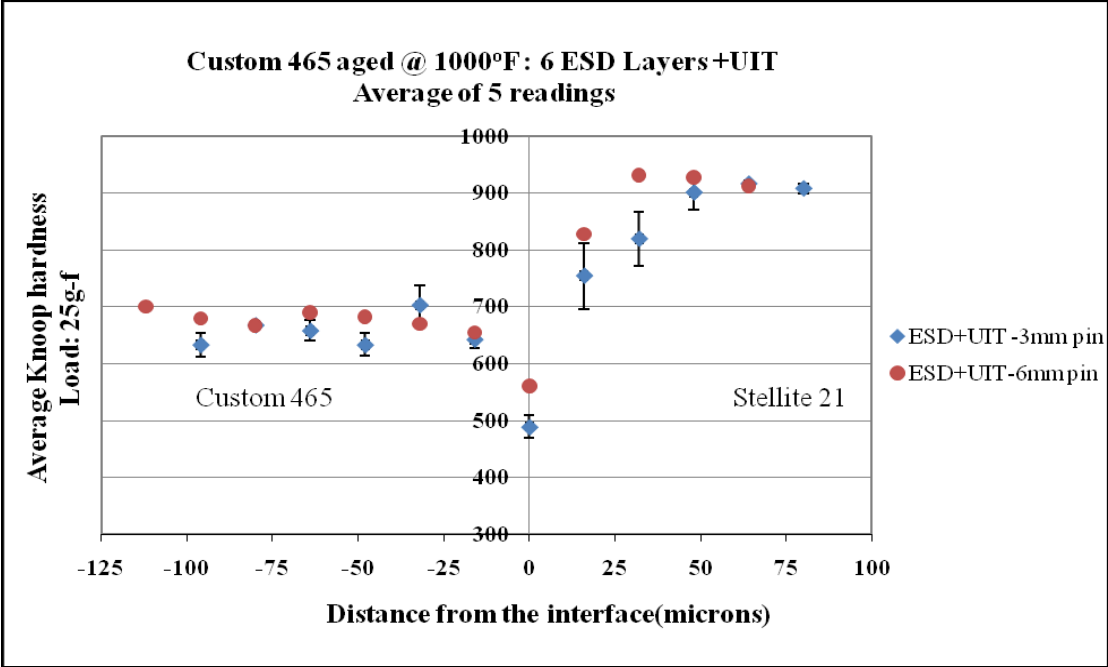

Figure.53. Hardness depth profile for ESD +UIT on aged C465 alloy with two UIT pin sizes

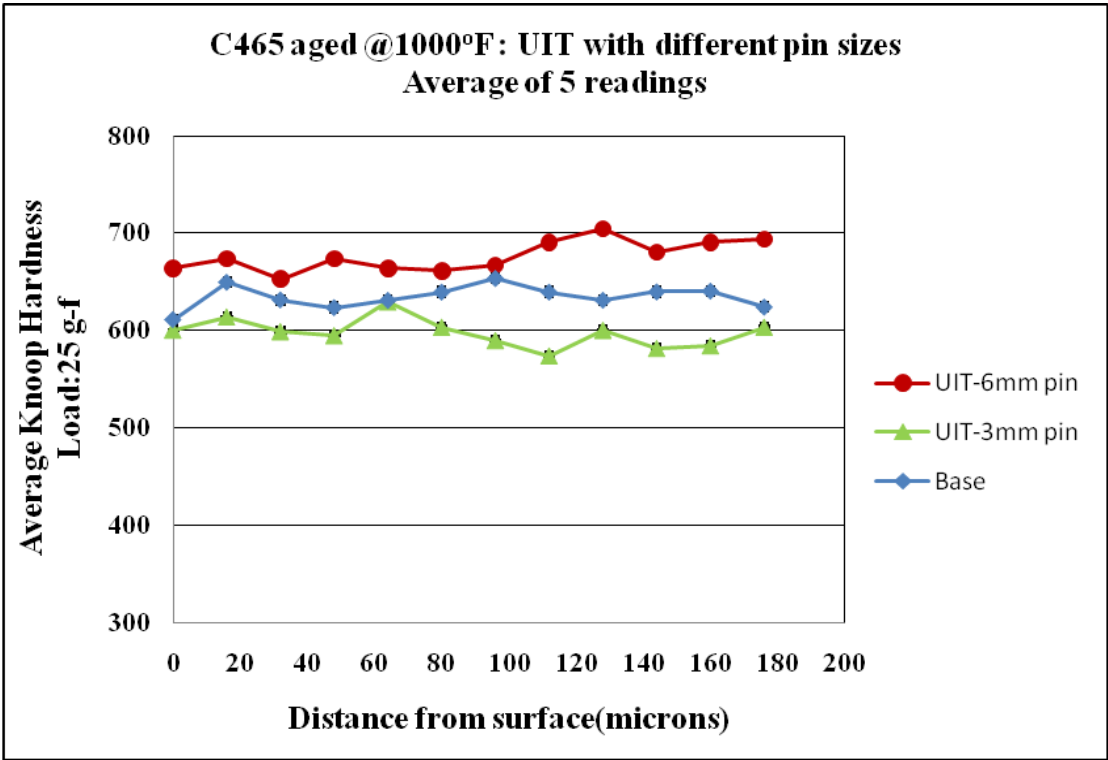

Figure.54. Hardness depth profile for UIT on aged C465 alloy treated with two UIT pin sizes

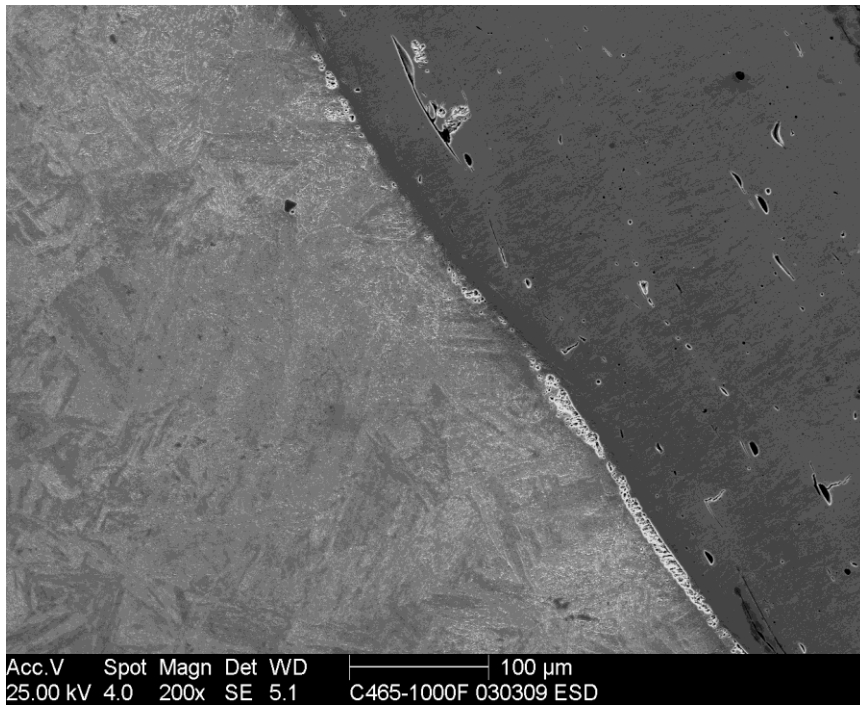

Figure.55.SEM cross section image for C465 aged @ 1000F- 200X

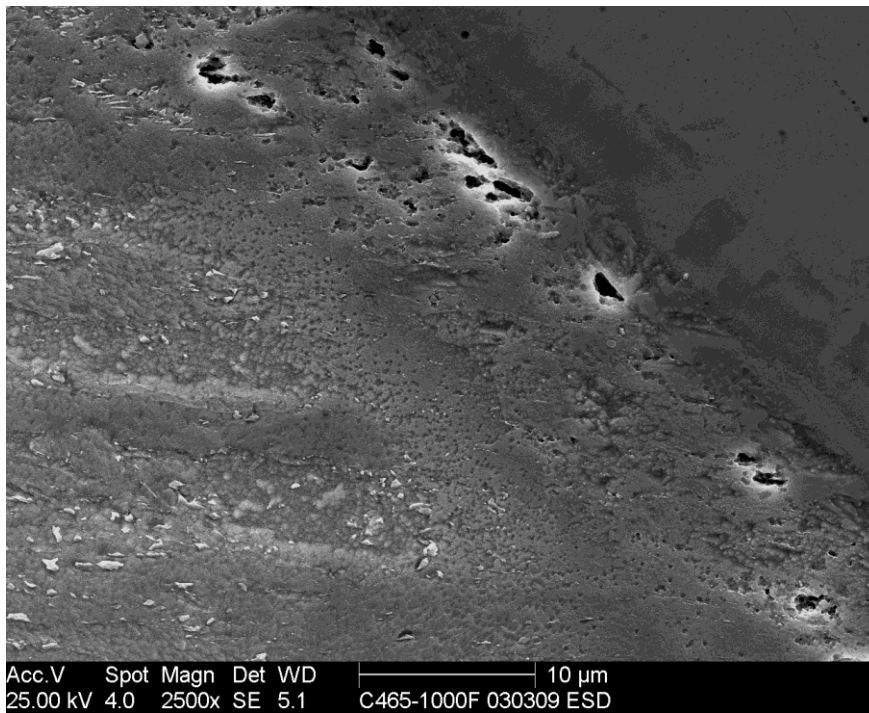

Figure.56.SEM cross section image for C465 aged @ 1000F- 2500X

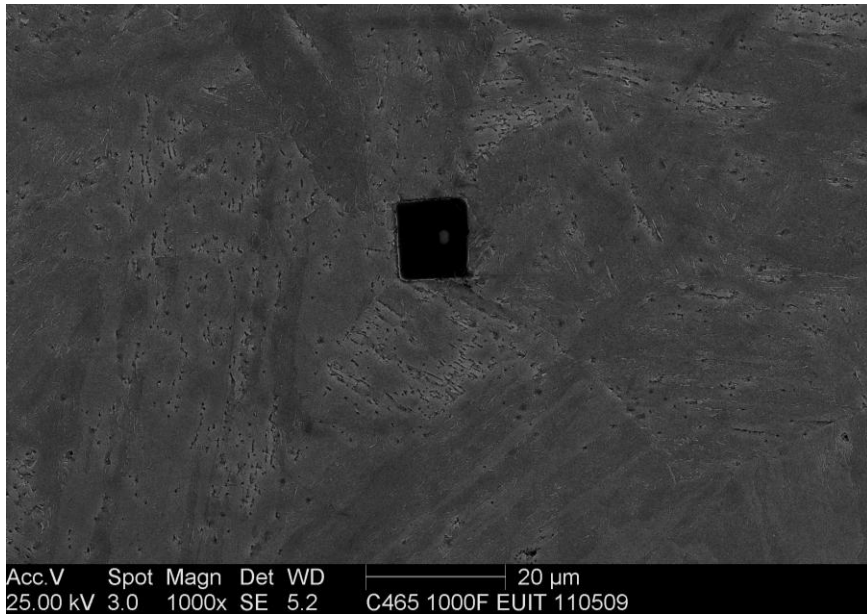
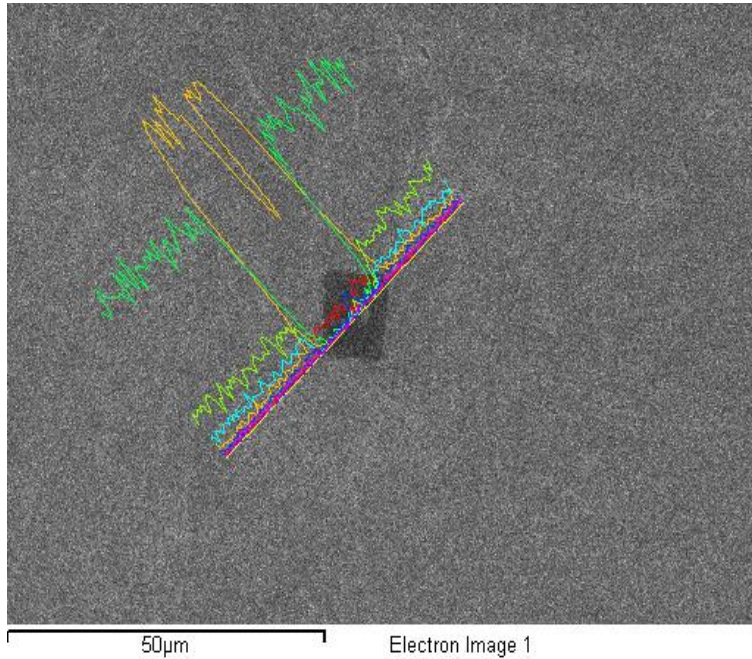
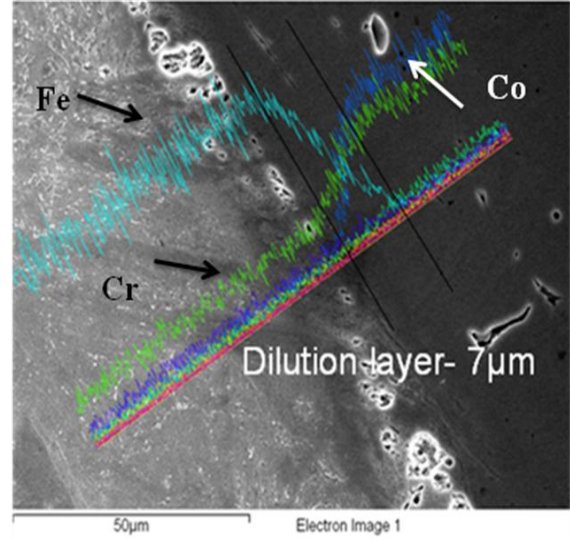
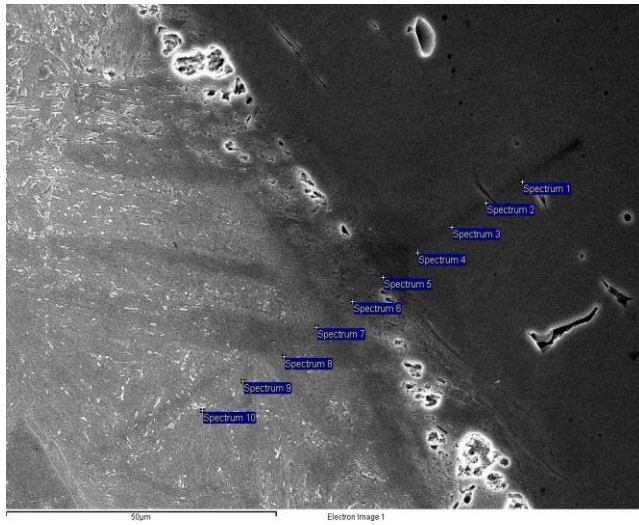

Figure.57.SEM cross section image of C465 aged @ 1000F with Ti_xN inclusion



Element	Weight %
Carbon	2.40
Nitrogen	26.82
Oxygen	1.21
Titanium	68.67
Iron	0.85

Figure.58. EDX line scan of Inclusion in C465 aged @ 1000F inclusion Elemental Composition



Element	Chromium	Iron	Cobalt	Nickel	Molybdenum	Titanium
Stellite 21	27.81	2.96	57.01	2.72	4.58	0.00
Spectrum 2	27.75	3.11	55.91	2.80	4.56	0.08
Spectrum 3	26.65	7.48	53.31	3.30	4.22	0.10
Spectrum 4	18.14	45.61	21.52	7.76	1.82	1.01
Spectrum 5	11.72	72.1	0.18	10.15	0.95	1.54
Spectrum 6	11.85	71.71	0.09	10.43	0.88	1.5
Spectrum 7	11.65	72.15	0.00	10.42	0.84	1.54
Substrate	11.69	72.65	0.00	10.39	0.66	1.56

Figure.59. EDX spectrum compositions and line scan of Custom 465 aged @ 1000F

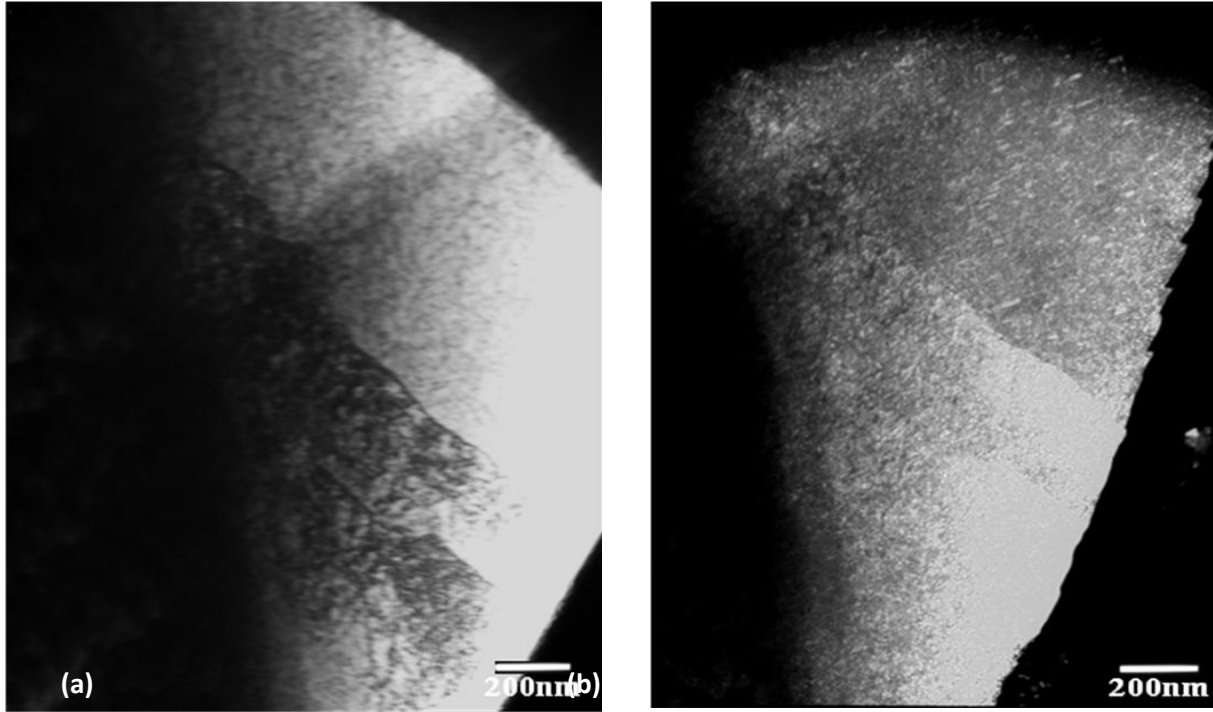

Figure 60 : TEM image of precipitates in Custom 465 substrate aged at 1000°F (a) Bright field image (b) Dark field image – no ESD/UIT treatment

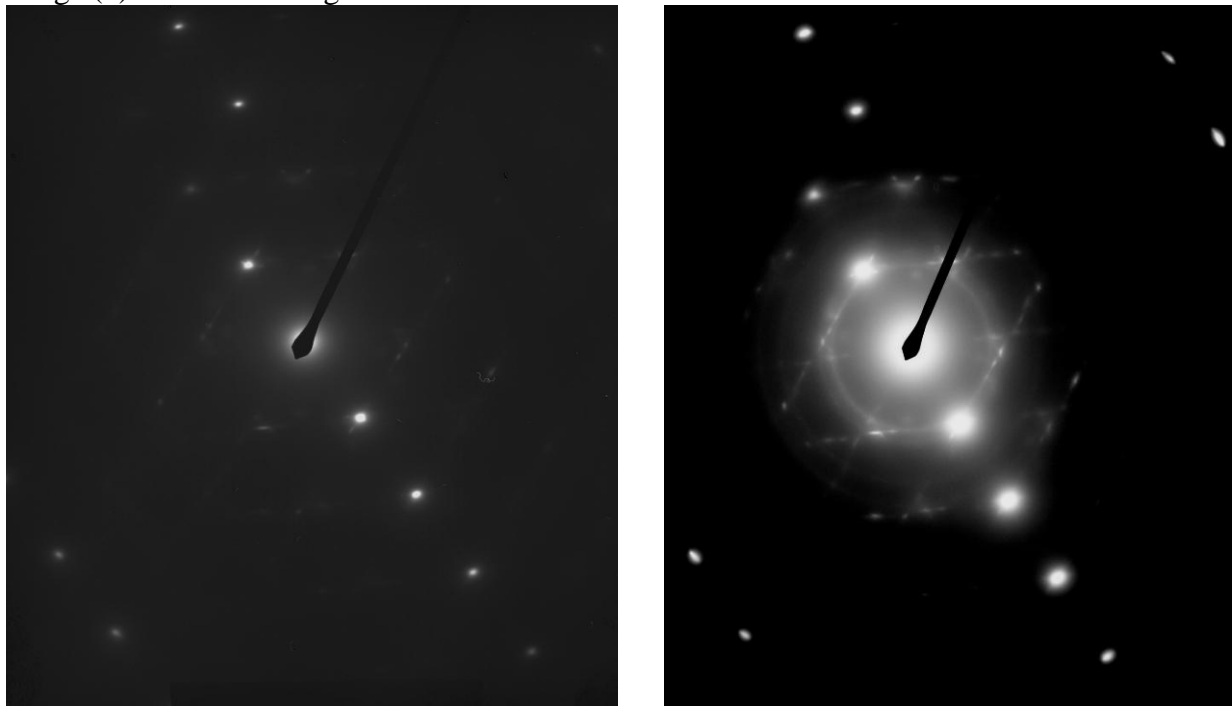

Figure 61 : SADP of bright field image in figure 60

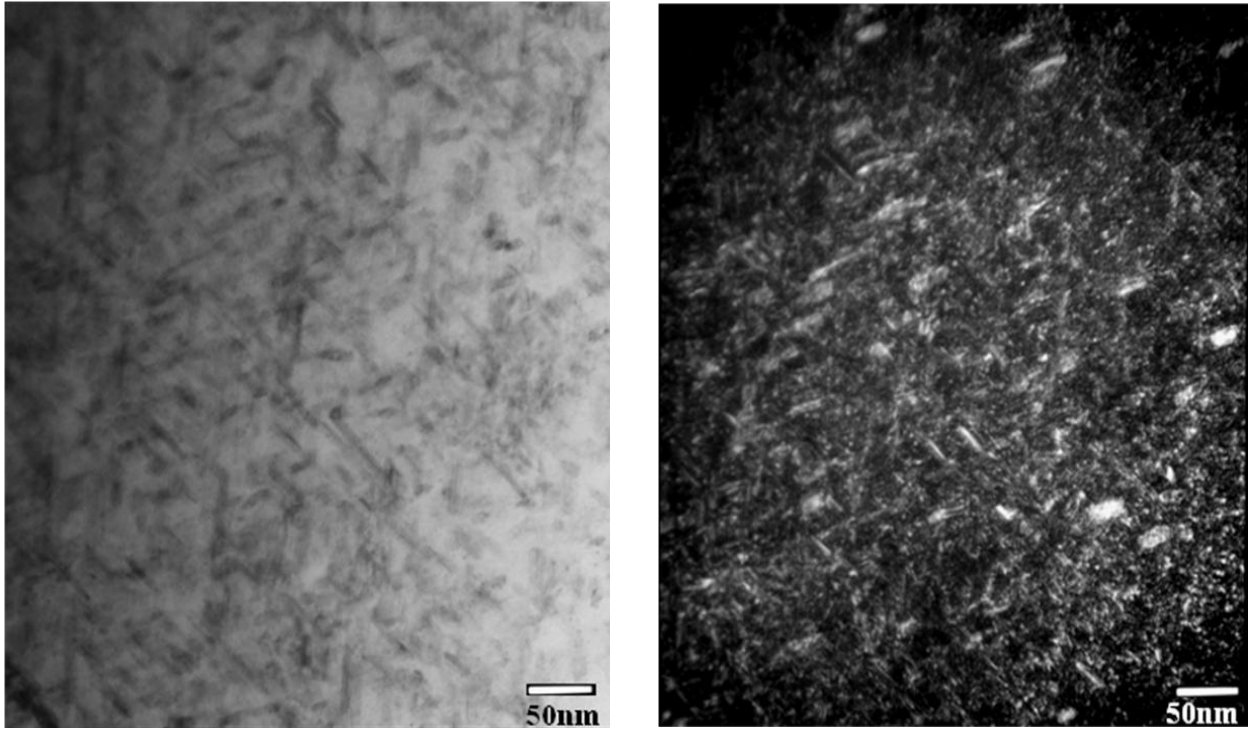

Figure 62 :Bright field and dark field TEM images showing precipitates in Custom 465 substrate aged at 1000°F –no ESD/UIT treatment

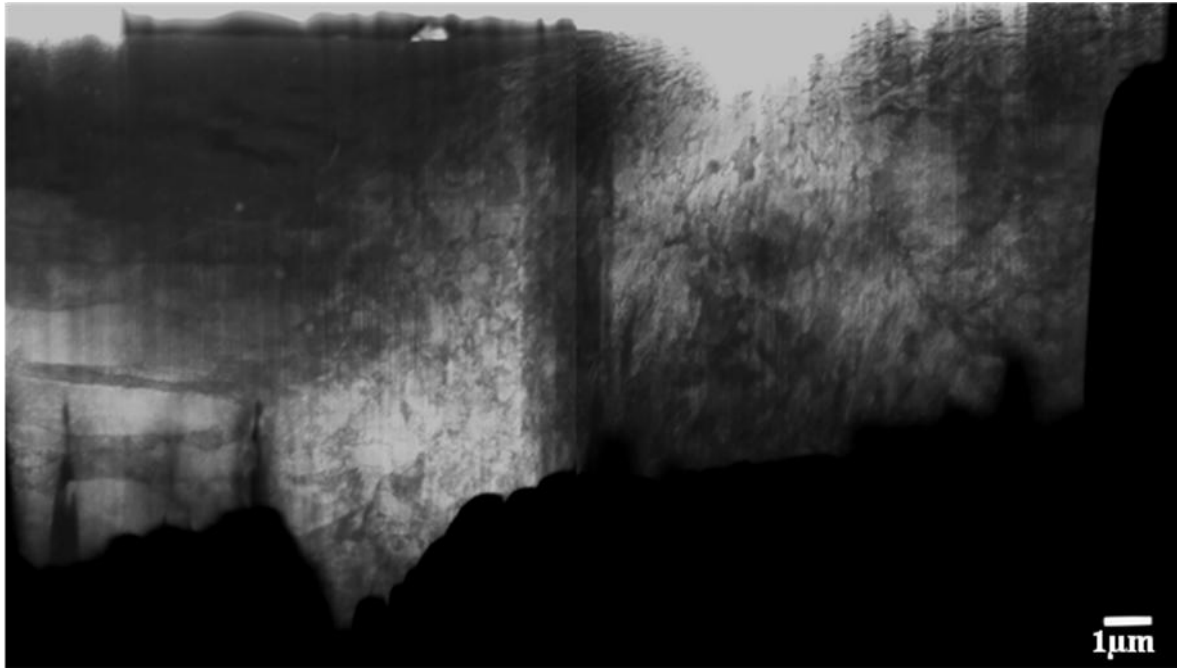

Figure 63(a) : Low magnification TEM image showing fine grains in the ESD treated substrate

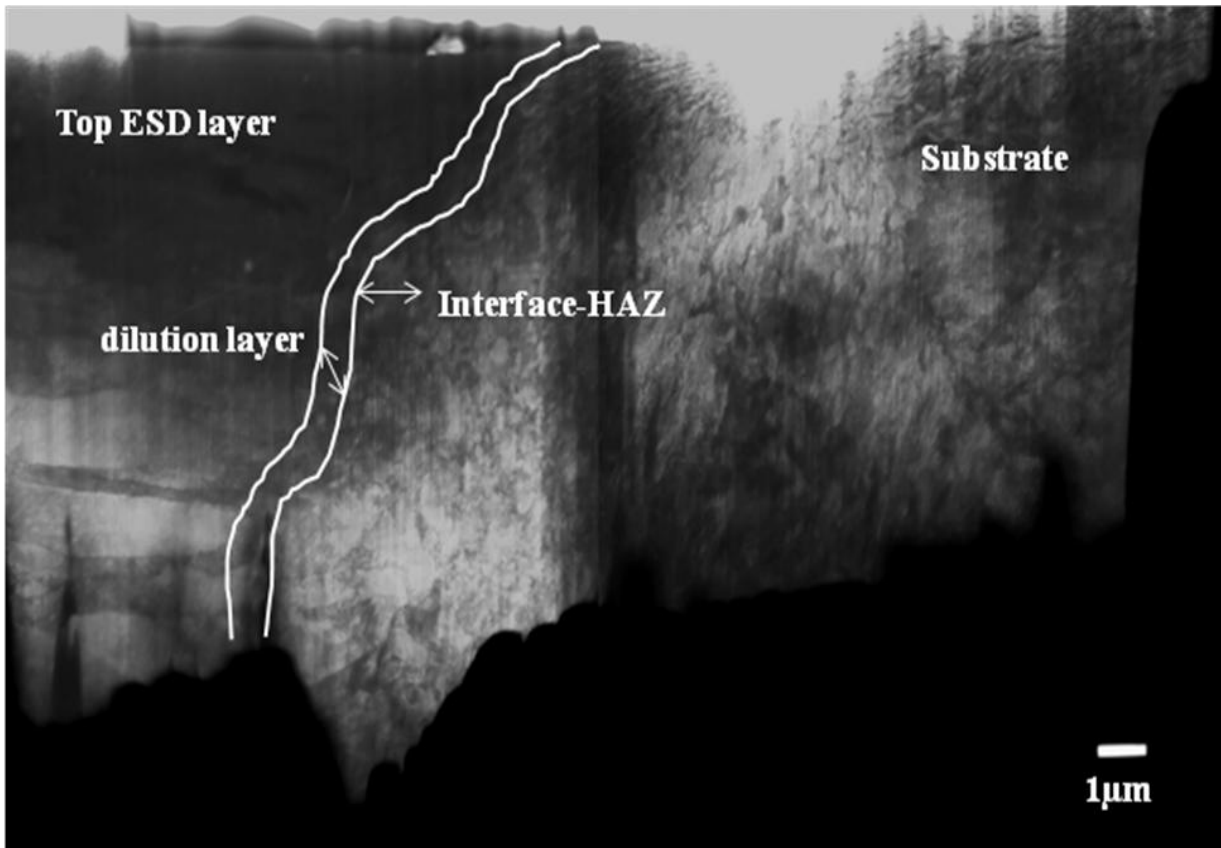

Figure 63 (b) :Cross-sectional TEM micrograph Stellite 21 deposited on Custom 465 aged at 1000°F-SAD patterns of TOP ESD layer, dilution layer, HAZ and the substrate- ESD treated

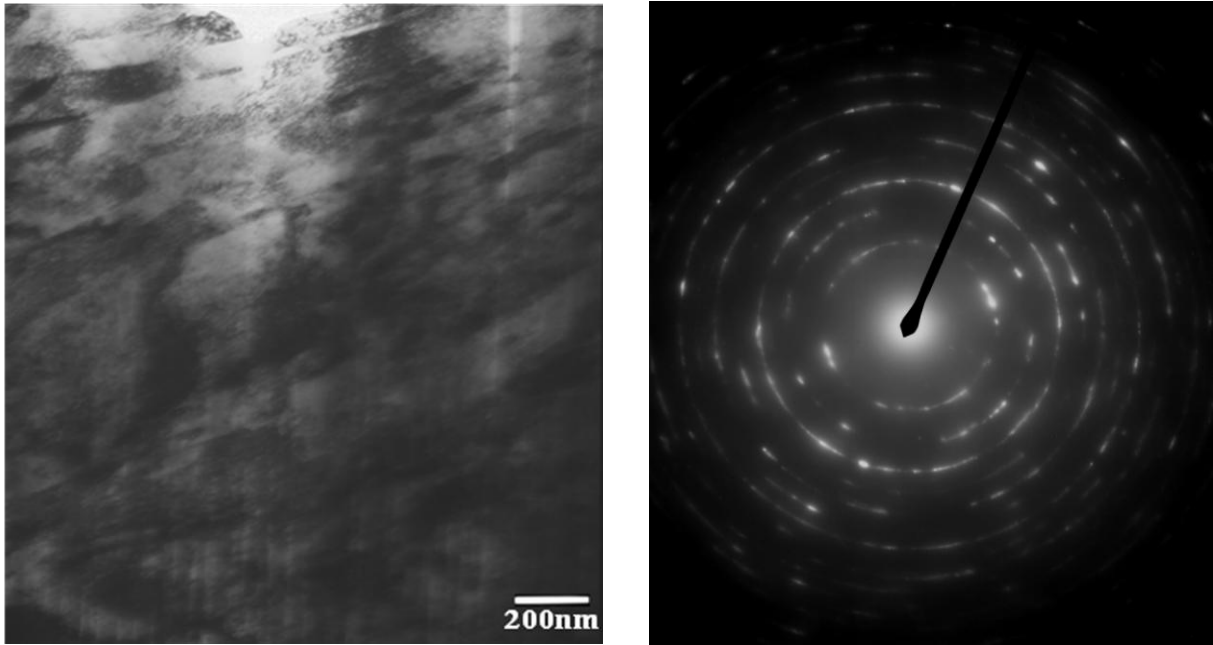

Figure 64 : TEM micrograph and SAD pattern of Custom 465 substrate aged at 1000°F- ESD

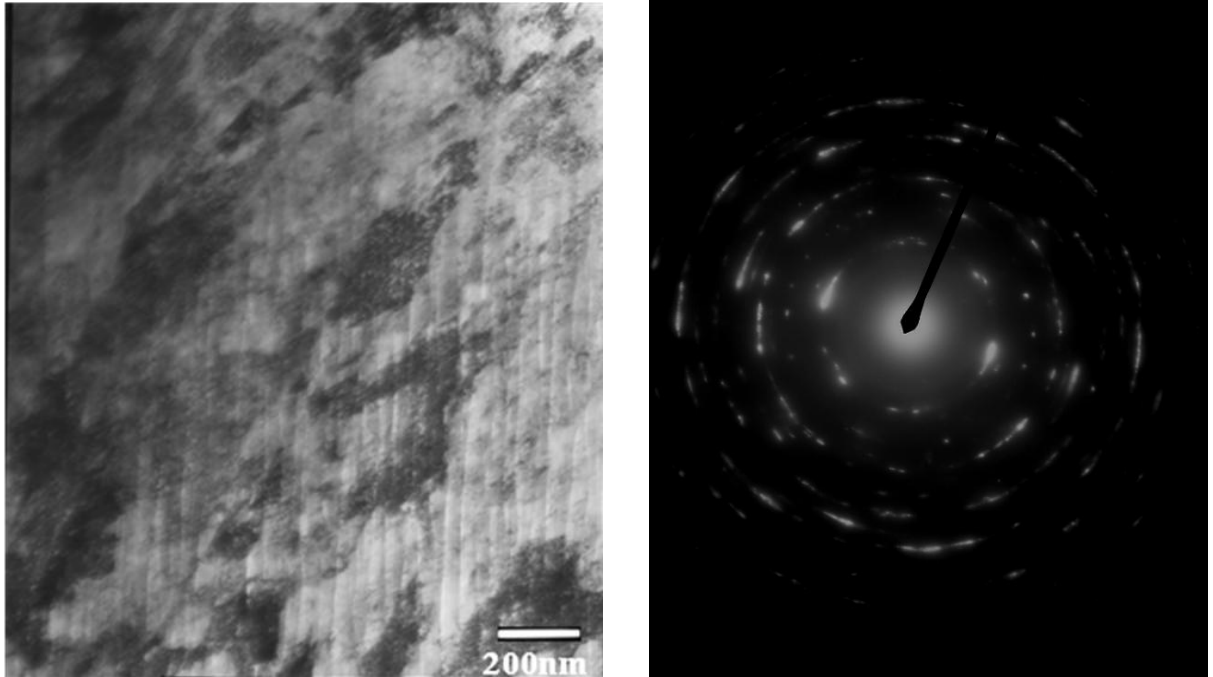

Figure 65 : TEM micrograph and SAD pattern of HAZ in Custom 465 aged at 1000°F- ESD

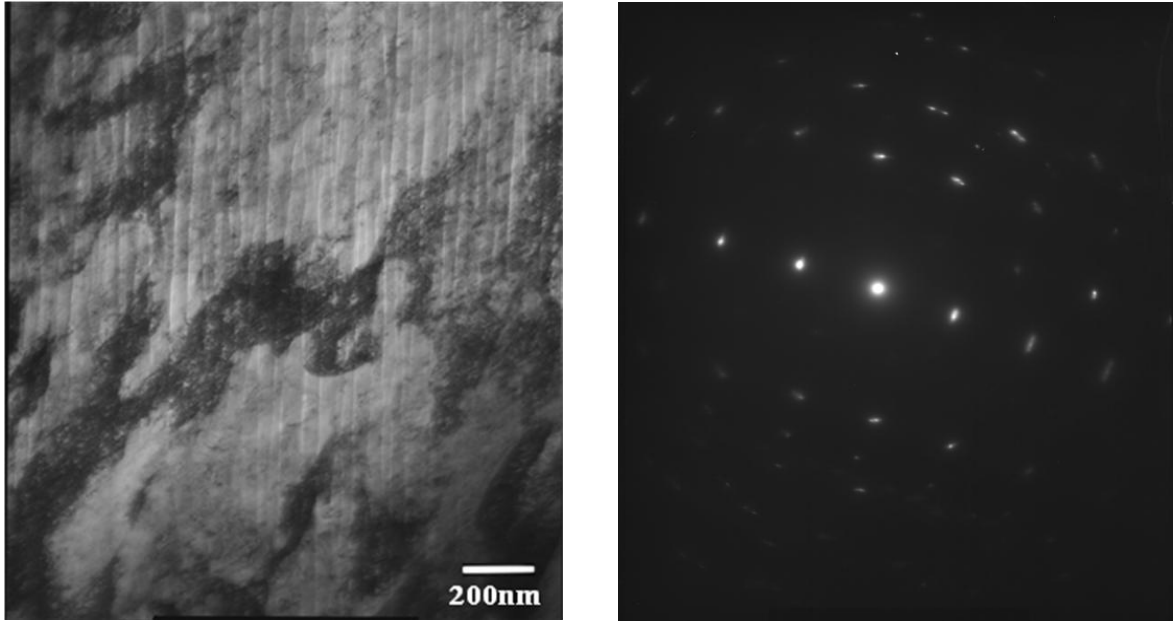

Figure 66: TEM micrograph and SAD pattern of mixing layers (1st & 2nd ESD layers) -ESD

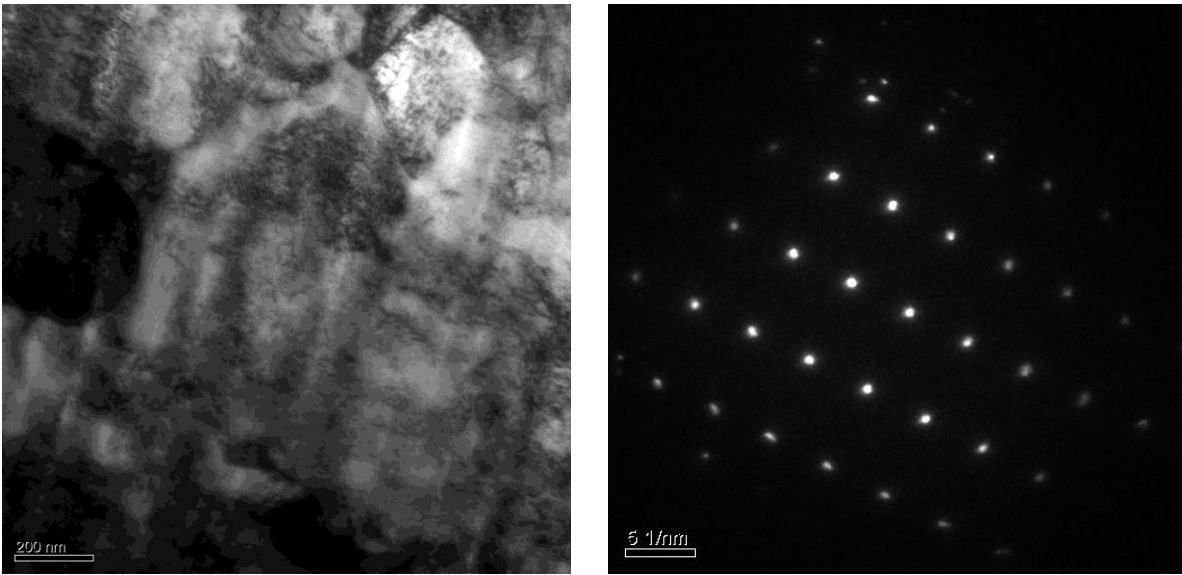

Figure 67: TEM micrograph and SAD pattern of mixing layers (1st & 2nd ESD layers) -ESD

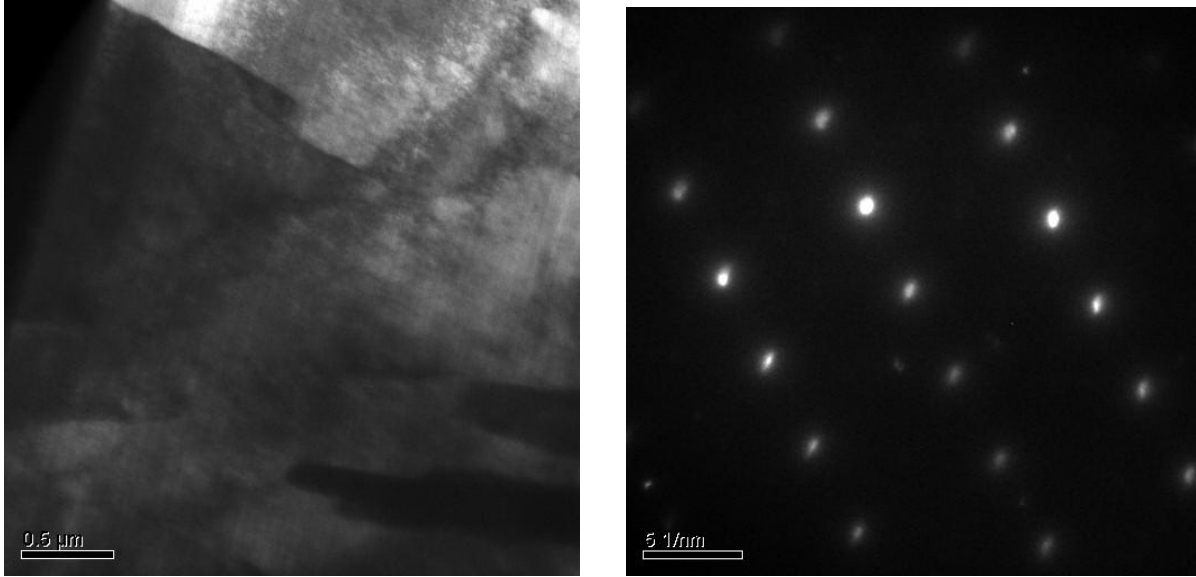

Figure 68: TEM micrograph and SAD pattern of Top ESD layers-ESD treated

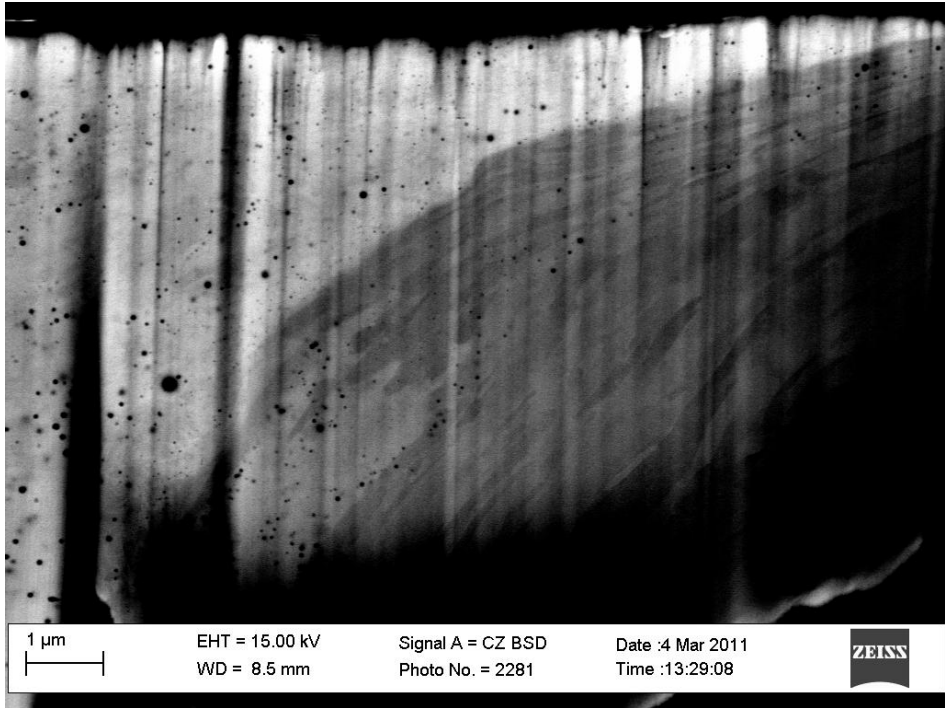

Figure 69: Back Scatterd SEM micrograph of Custom 465 aged at 1000°F showing compositional change at the HAZ interface- ESD+UIT treated

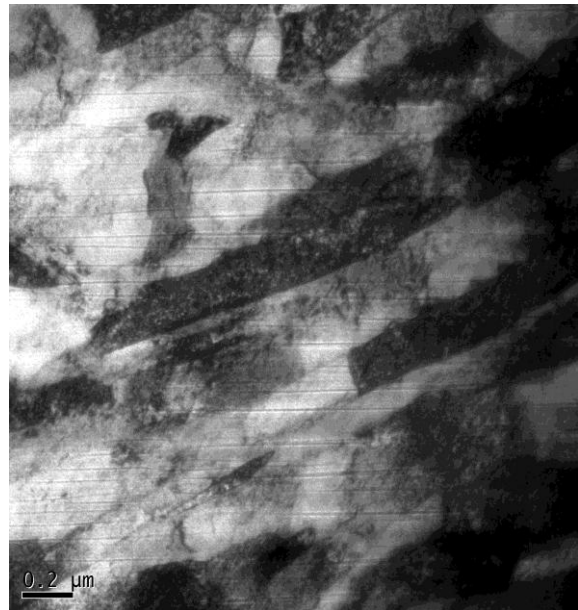
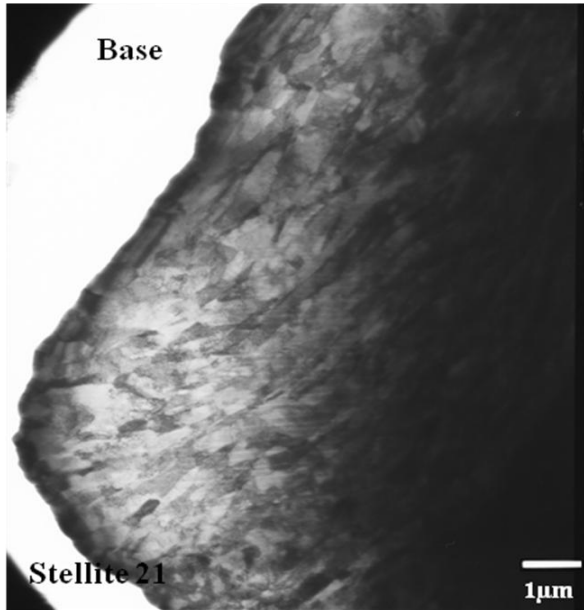

Figure 70: Lath structure in Custom 465 alloy aged at 1000°F- ESD+UIT treated

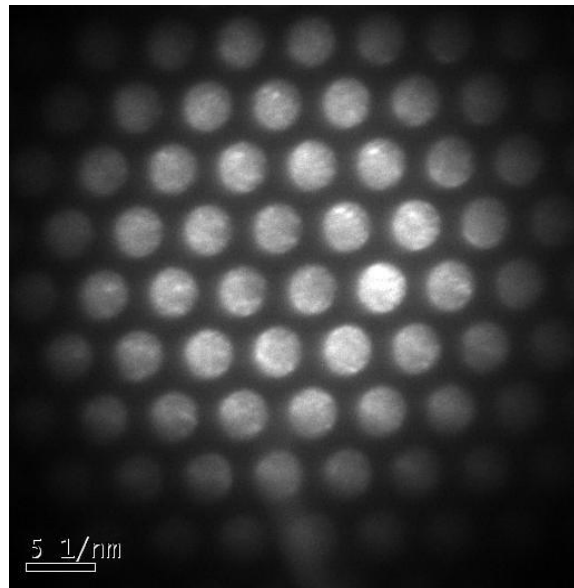
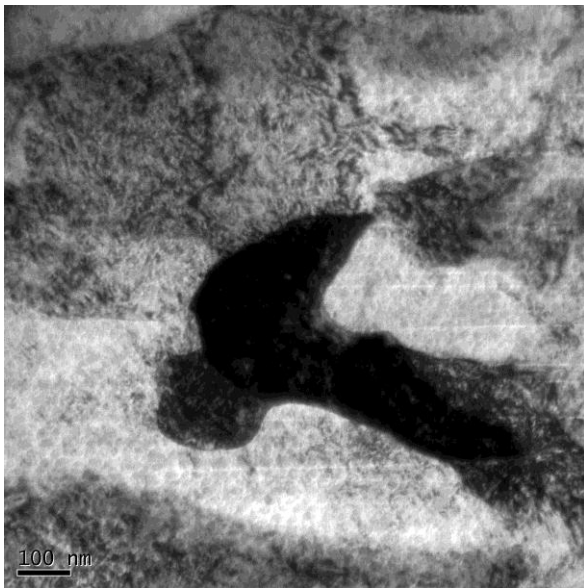

Figure 71 : TEM micrograph and micro diffraction pattern of Custom 465 aged at 1000°F – ESD+UIT treated

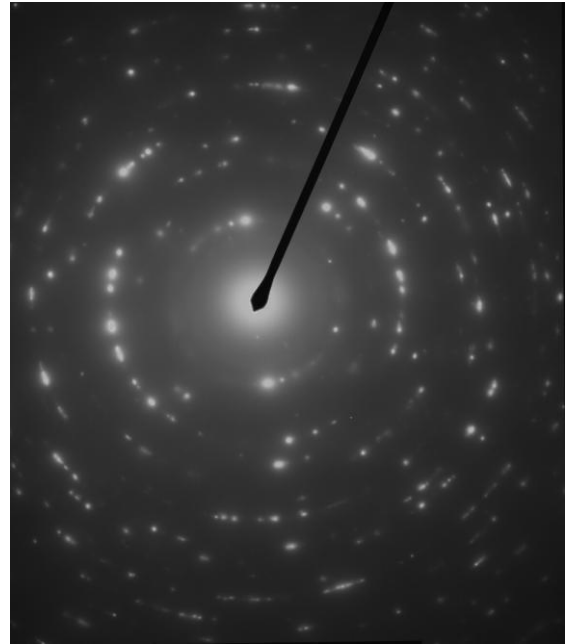
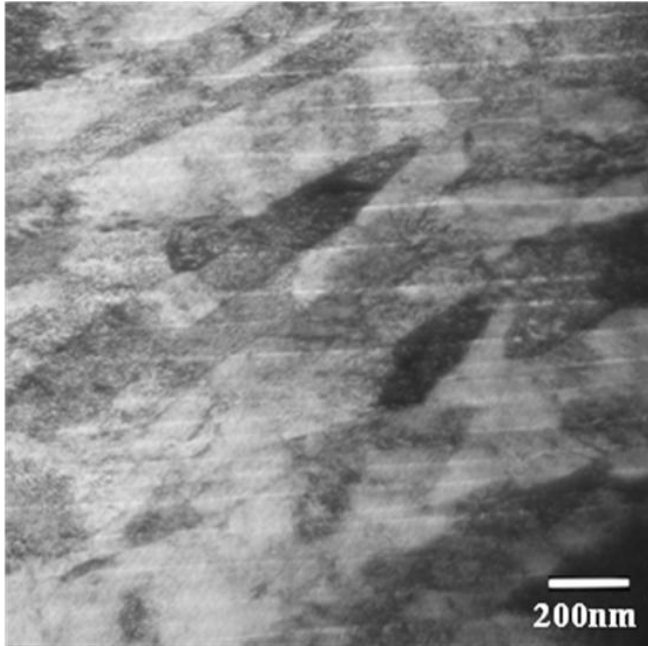

Figure 72: TEM micrograph of UIT treated stellite 21- ESD+UIT treated

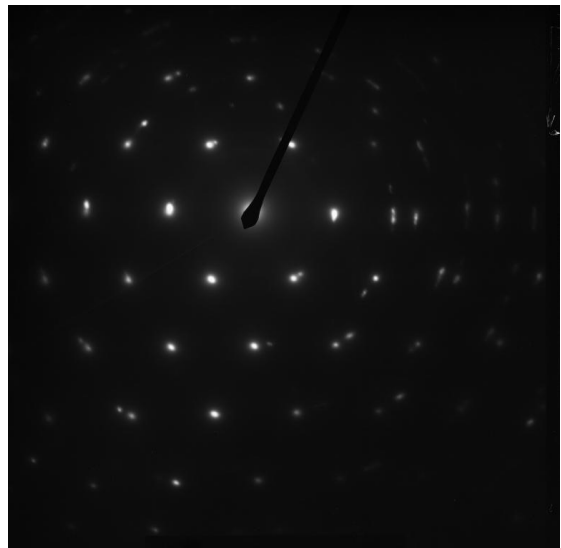
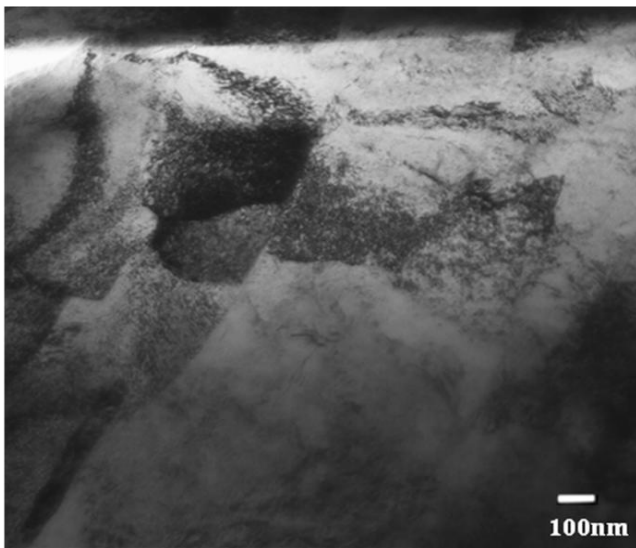

Figure 73 : TEM micrograph and SAD pattern of HAZ Custom 465 aged at 1000°F -ESD+UIT treated

300M alloy tempered at 400°F

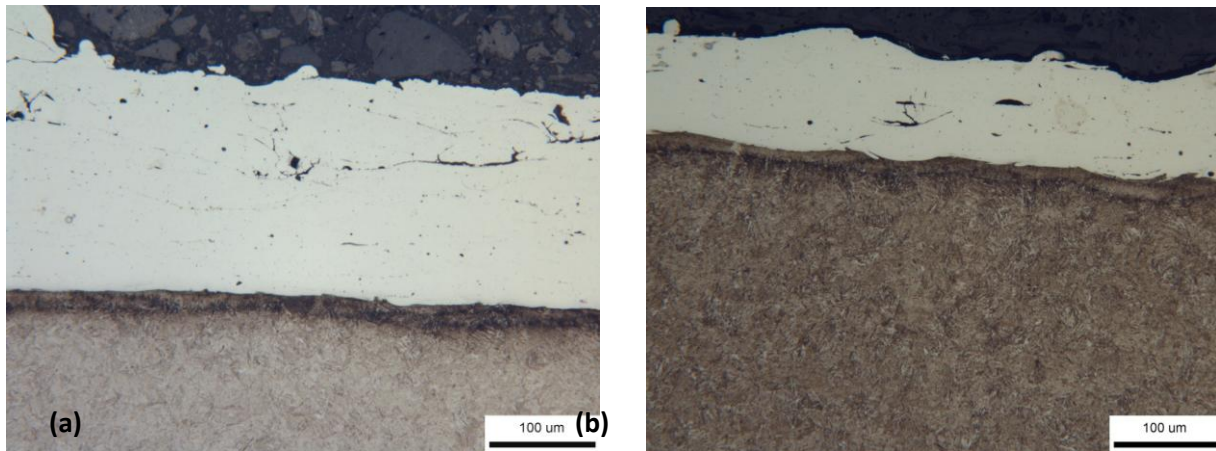

Figure.74. (a) 300M as Quenched- 18 ESD layers (b) 300M tempered @ 400F- 6 ESD layers

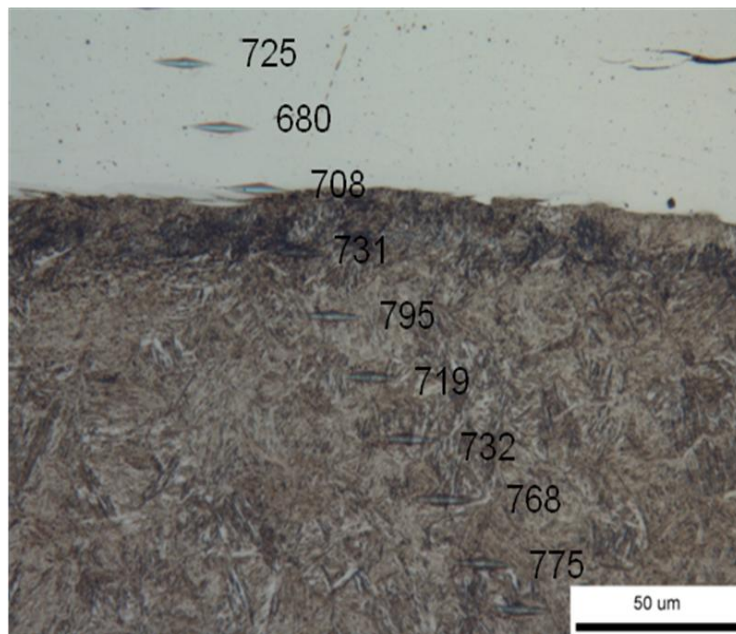

Figure.75. Microhardness profile for 300M tempered @ 400F -12 ESD Layers

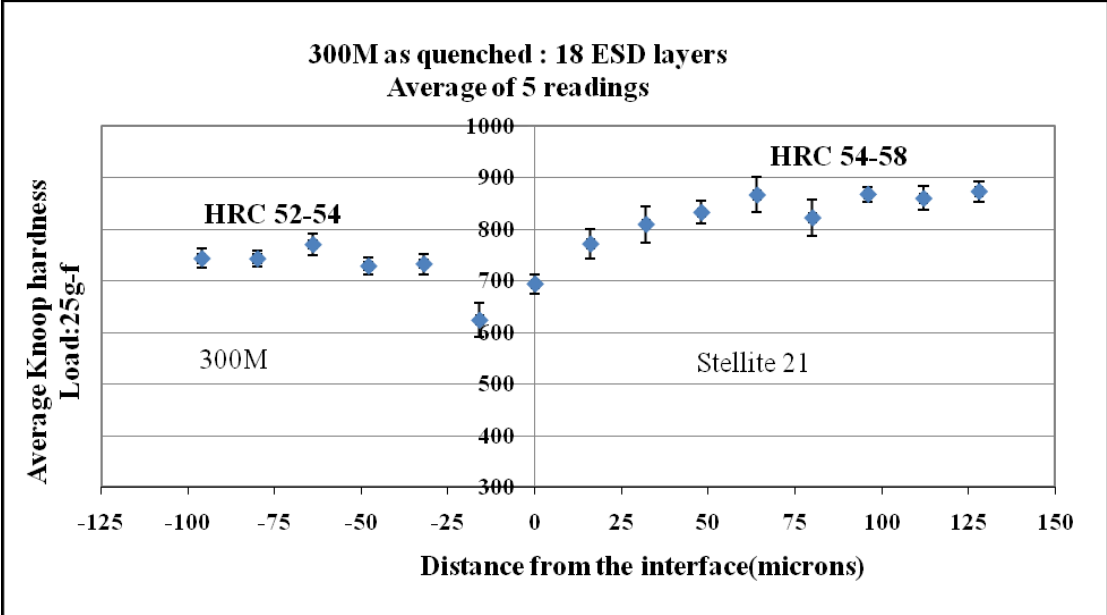

Figure .76. Hardness profile for ESD of Stellite 21 on as quenched 300M alloy

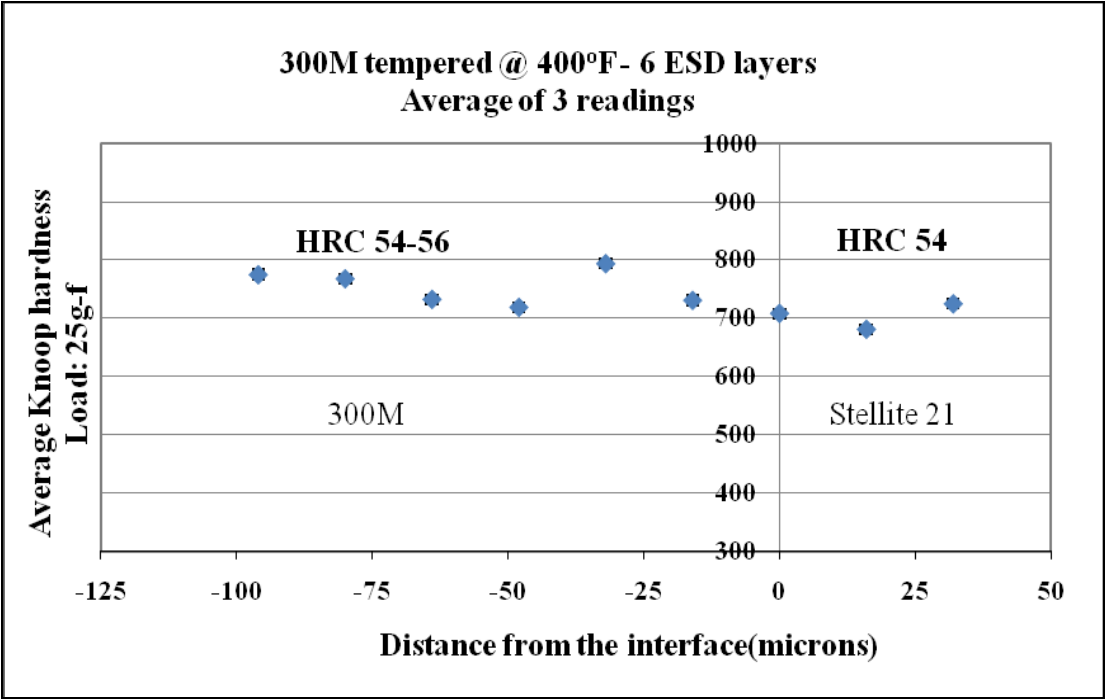

Figure.77. Hardness profile for ESD of Stellite 21 on tempered 300M alloy

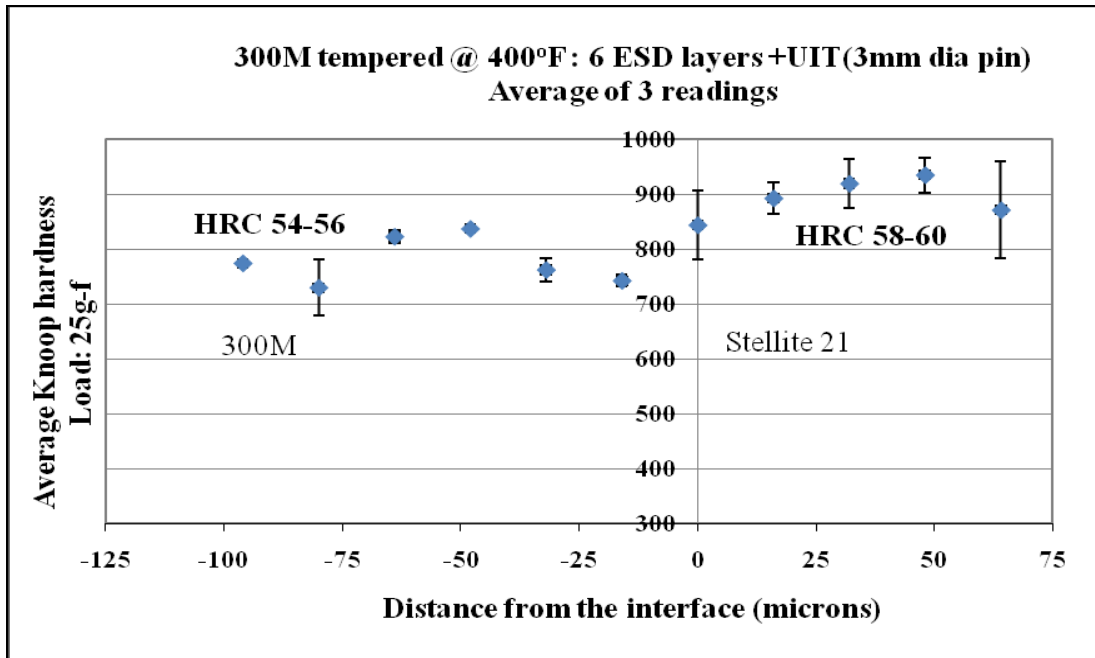

Figure.78. Application of UIT after ESD of Stellite 21 on tempered 300M alloy

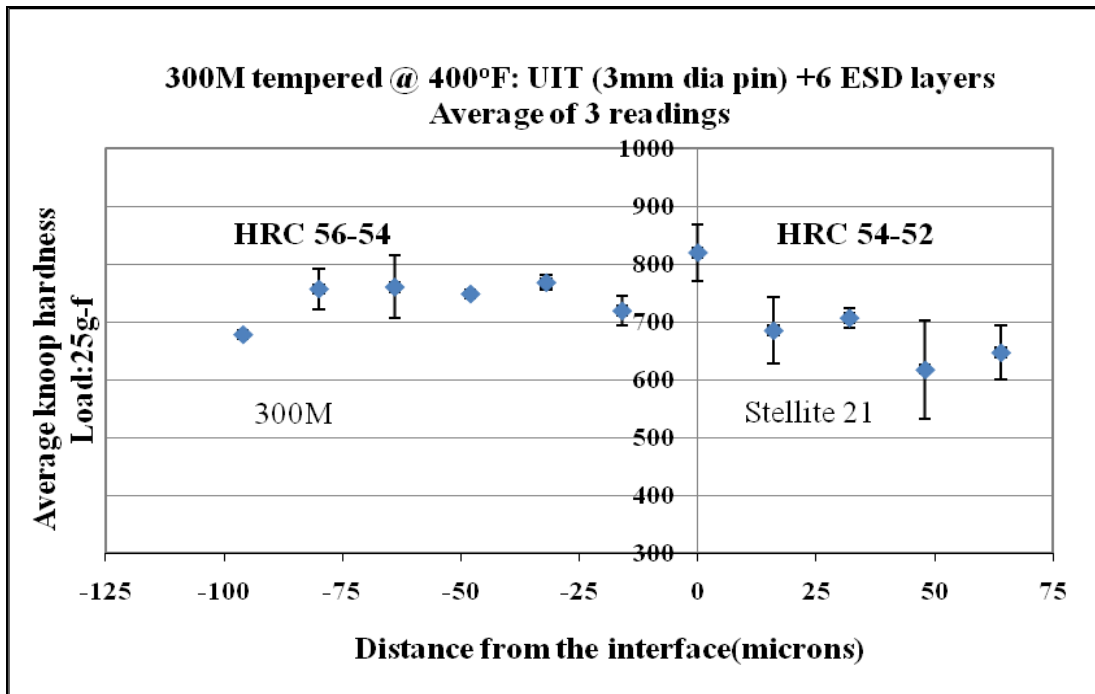

Figure.79. ESD of stellite 21 on UIT treated 300M alloy

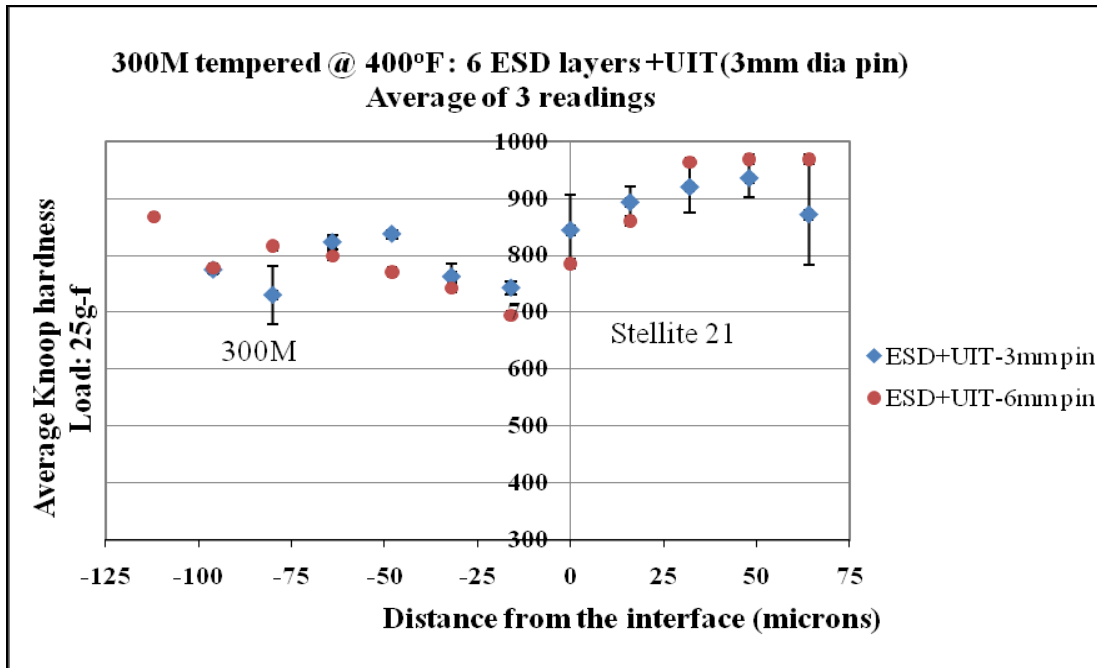

Figure.80. Hardness depth profile for ESD +UIT on tempered 300M alloy with two UIT pin sizes

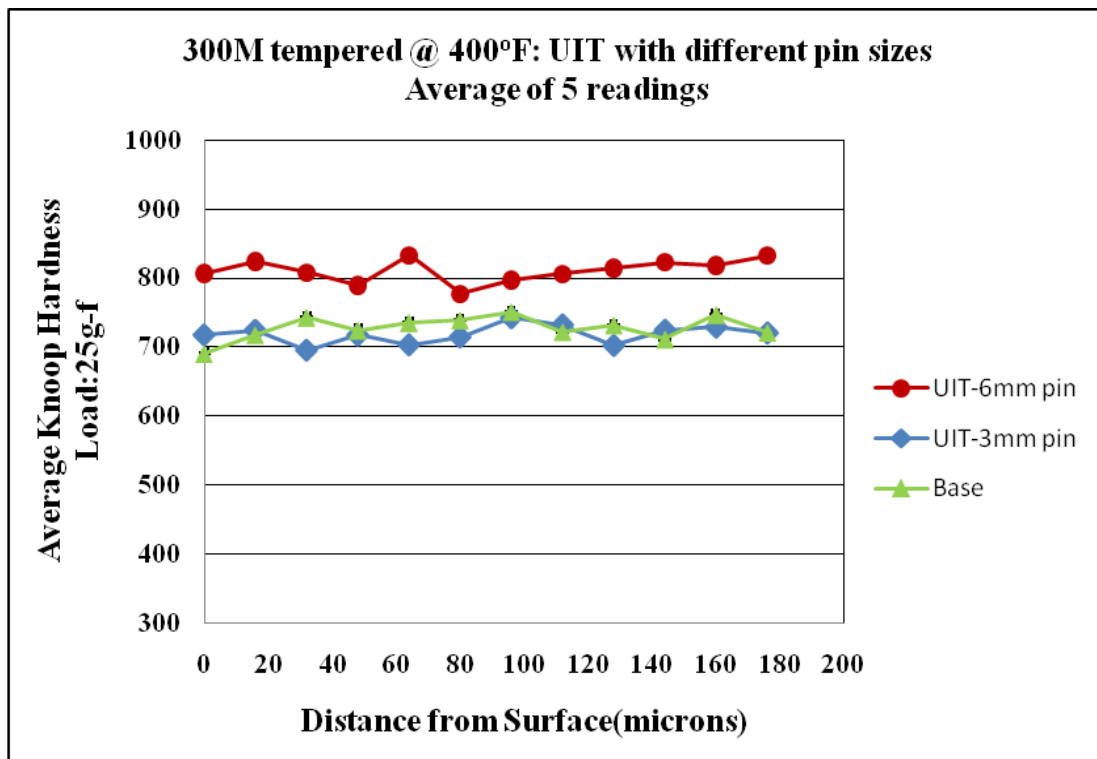

Figure.81. Hardness depth profile for UIT on tempered 300M alloy with two UIT pin sizes

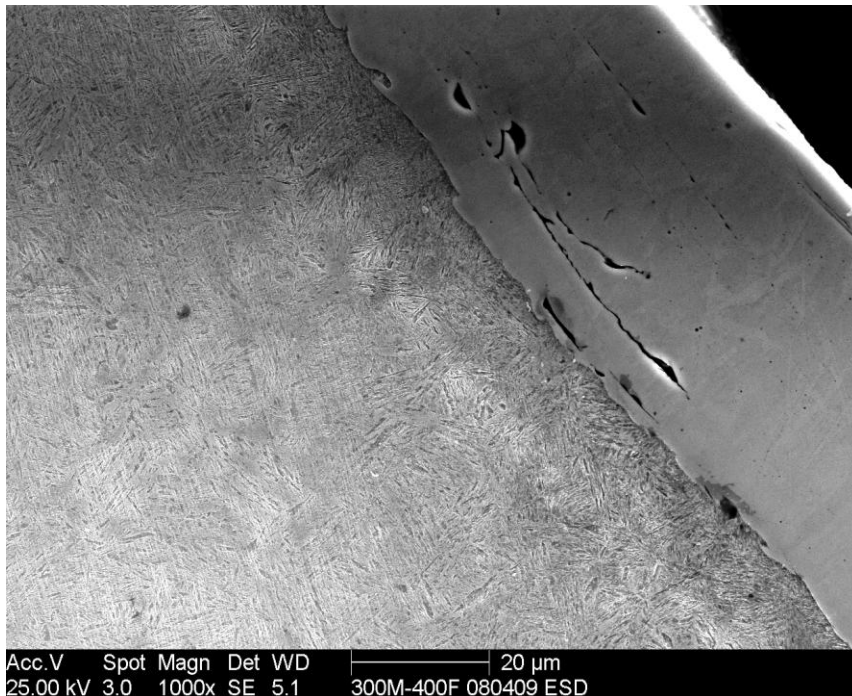

Figure.82. SEM Cross section image for 300M tempered@ 400F

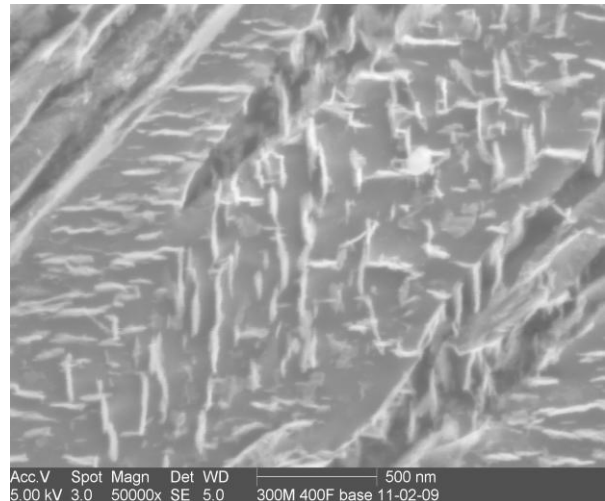
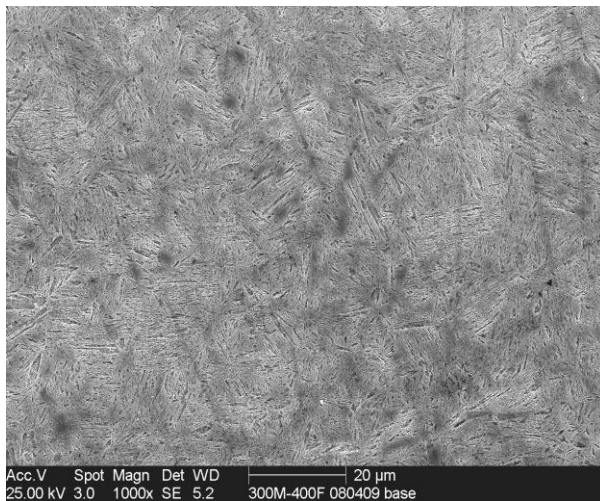
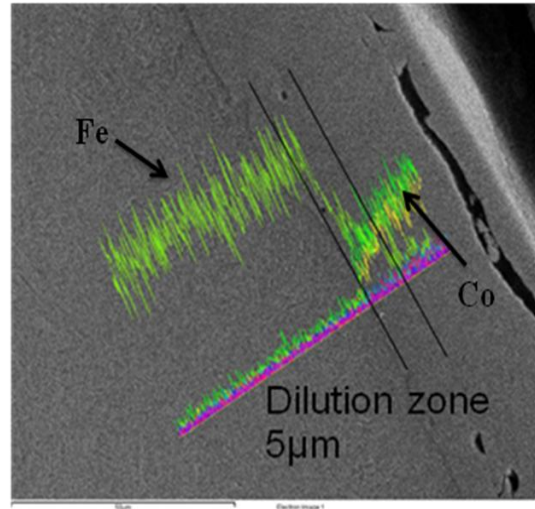
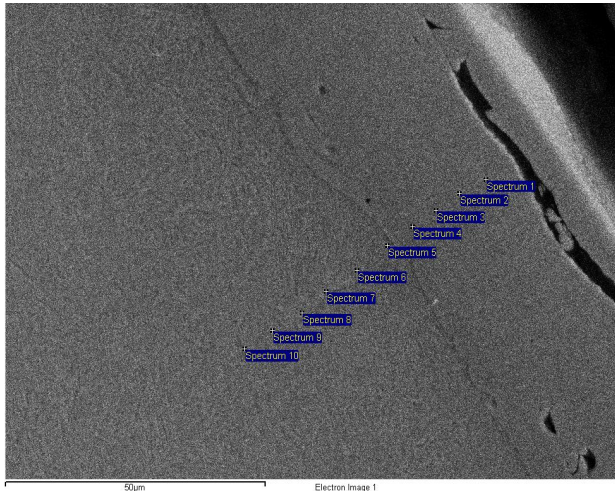

Figure.83. SEM cross section image for base material 300M tempered @ 400F showing carbide precipitates



Element	Silicon	Vanadium	Chromium	Iron	Cobalt	Nickel	Molybdenum
Stellite 21	0.91	0.0	26.87	2.5	54.05	2.6	5.01
Spectrum 2	0.88	0.08	25.98	6.99	52.46	2.38	4.18
Spectrum 3	0.66	0.01	24.92	9.29	51.55	2.78	3.94
Spectrum 4	1.02	0.06	18.56	29.76	38.39	2.4	3.17
Spectrum 5	1.16	0.15	1.81	90.23	0.47	1.58	0.23
Spectrum 6	1.39	0.01	1.24	89.35	0.01	1.58	0.0
Spectrum 7	1.23	0.0	0.92	91.39	0.13	1.65	0.0
Substrate	1.43	0.13	0.95	89.33	0.34	1.89	0.38

Figure.84. EDX spectrum composition and line scan on 300M tempered @ 400F-ESD; 12 layers

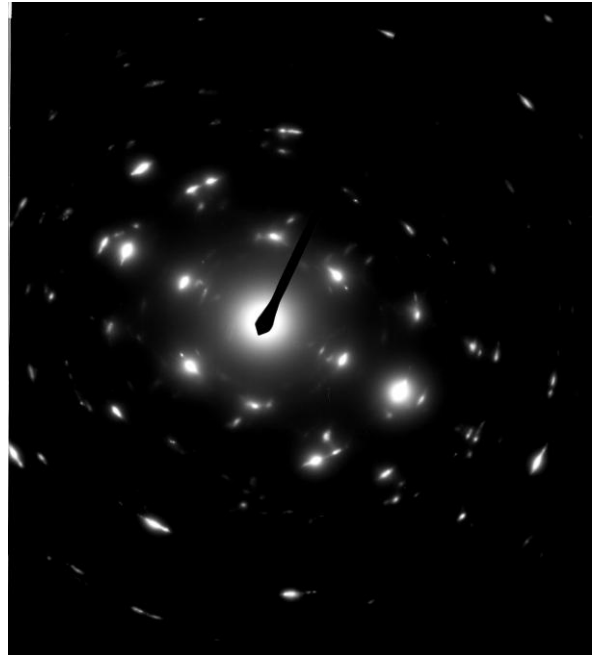
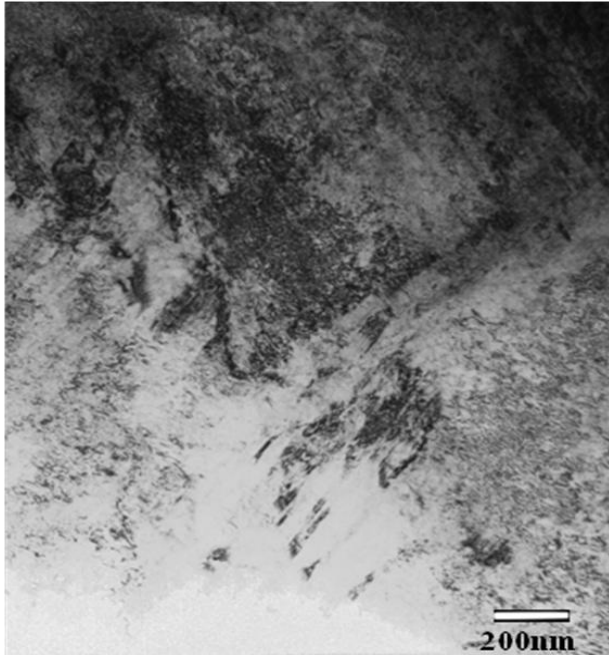

Figure 85: TEM micrograph of carbide precipitates in 300M substrate tempered at 400°F- no ESD/UIT treatment

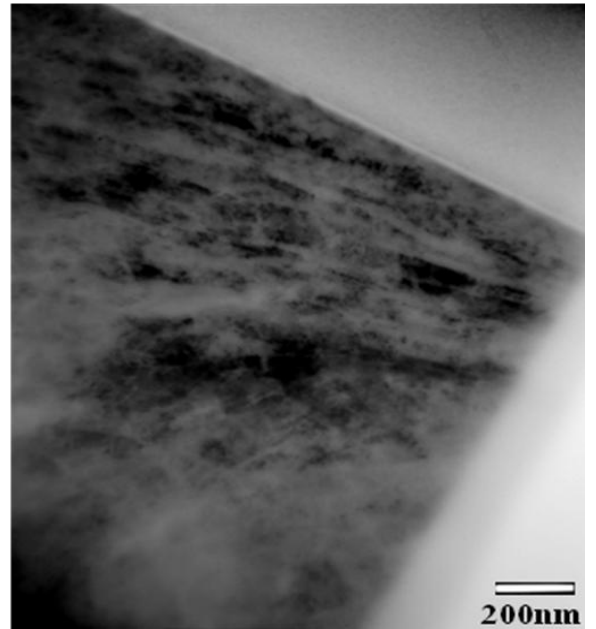
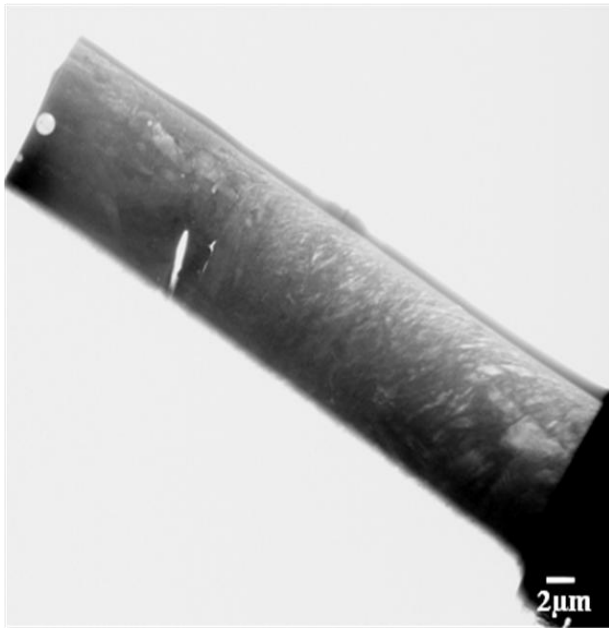

Figure 86: Low magnification TEM image of 300M alloy and martensitic lath structure in the substrate- ESD treated

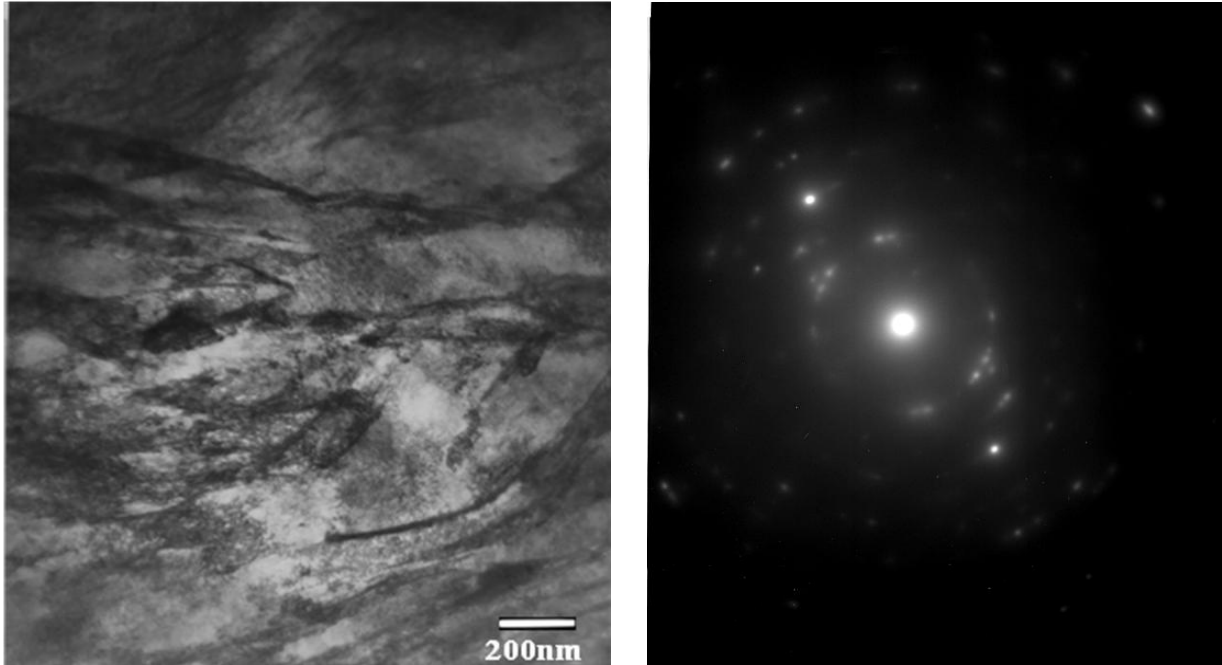

Figure 87: TEM micrograph and SAD pattern of UIT treated stellite 21- ESD+UIT treated

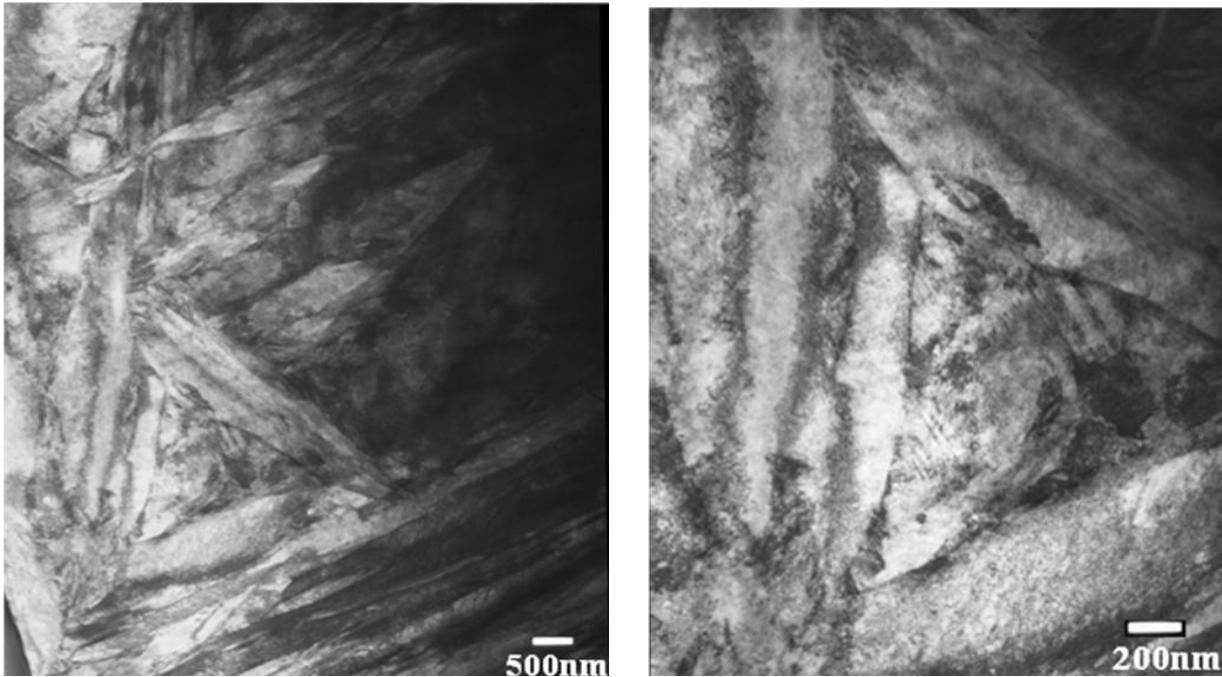

Figure 88: TEM micrographs of lath structure in sample taken at 1mm from UIT surface for 300M alloy tempered at 400°F – UIT treated

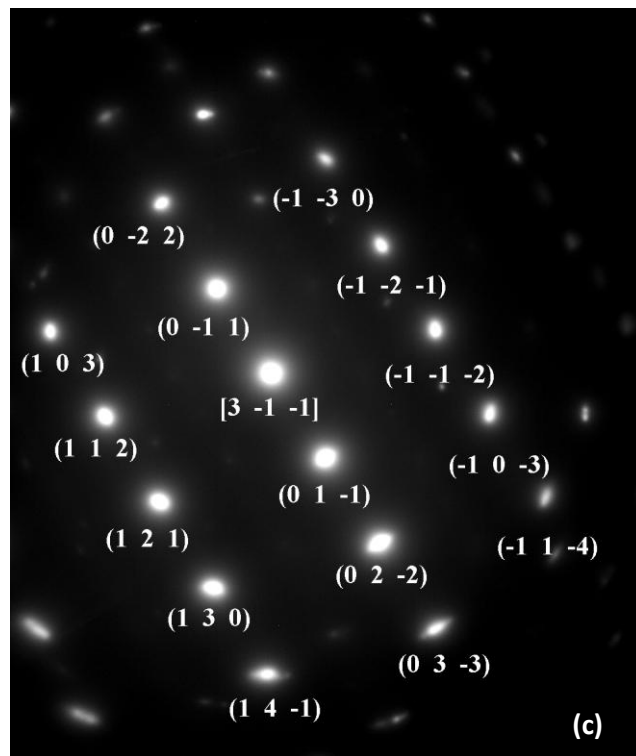
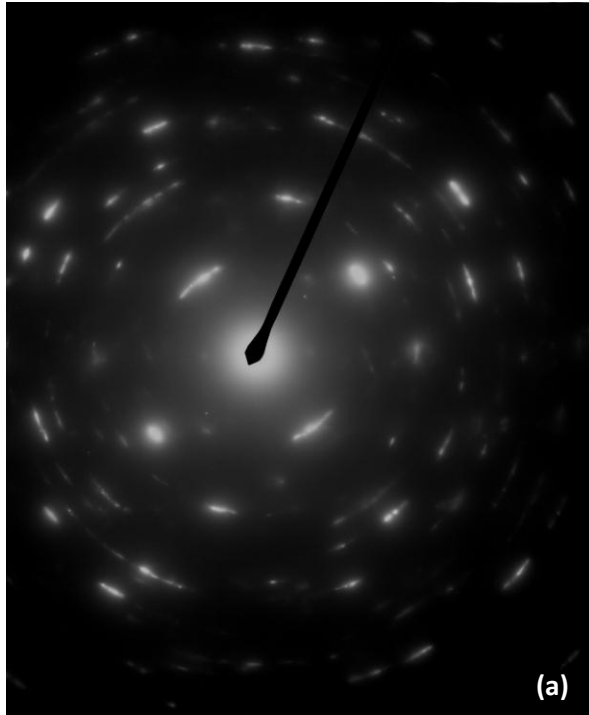

Figure 89: (a) SADP from multiple lath in figure 88, (c) SADP from single dark lath figure 89b, (b)- UIT treated

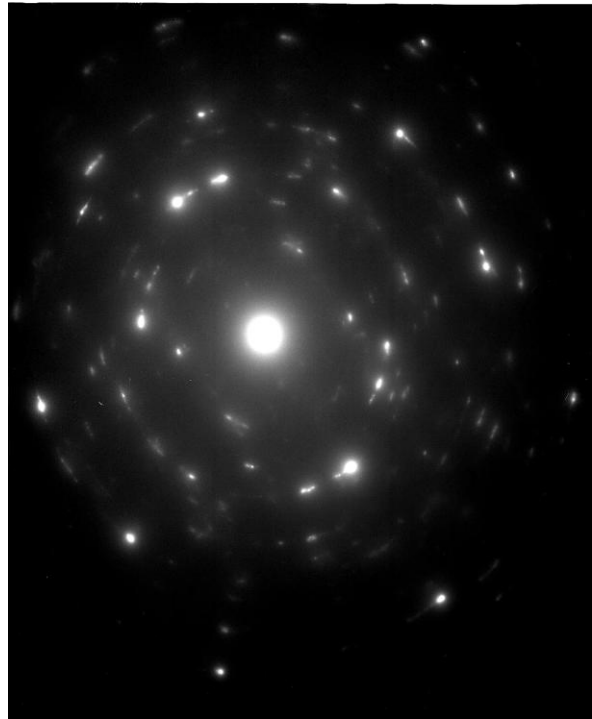
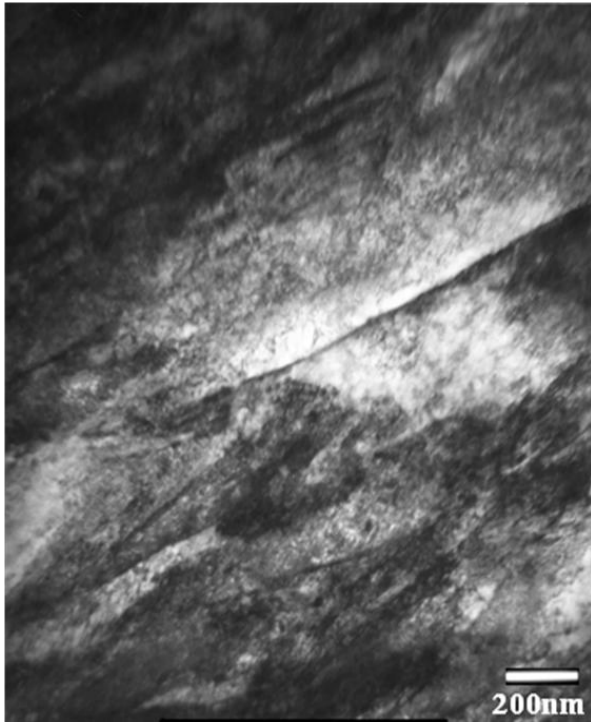

Figure 90: TEM micrographs of large lath structure in sample taken at 6mm from UIT surface for 300M alloy tempered at 400°F- UIT treated

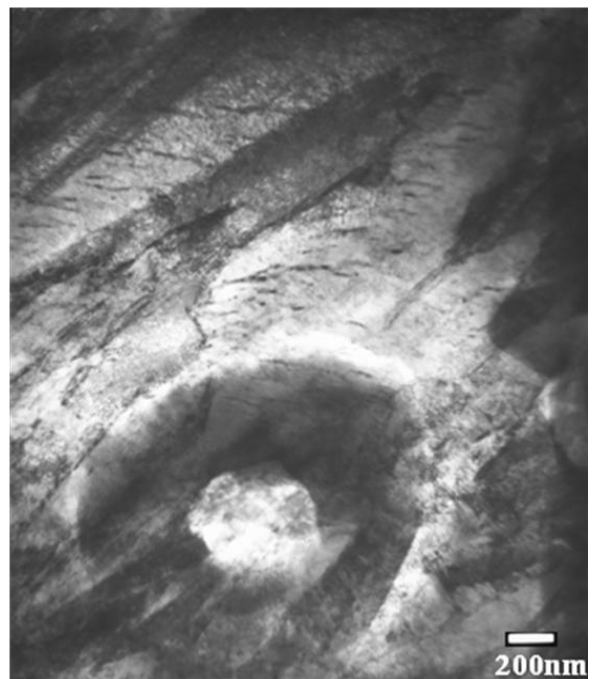
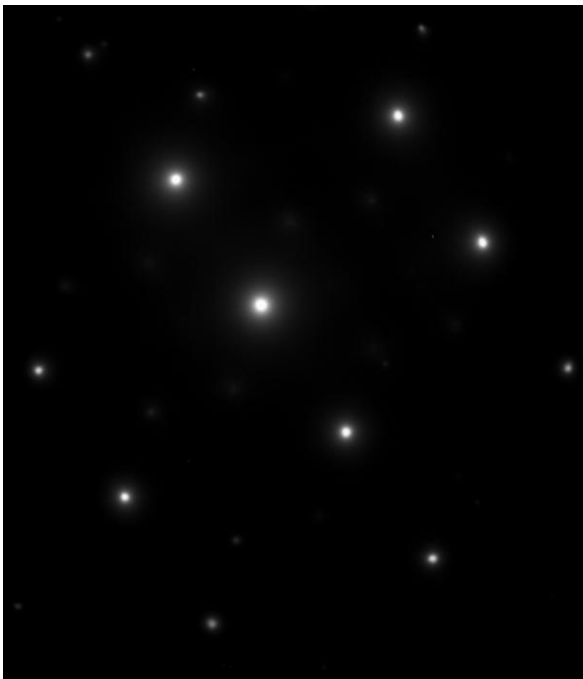

Figure 91: SADP of image in figure 90 (b) TEM image large inclusion in sample taken at 6mm from UIT surface – UIT treated

300M tempered at 575°F

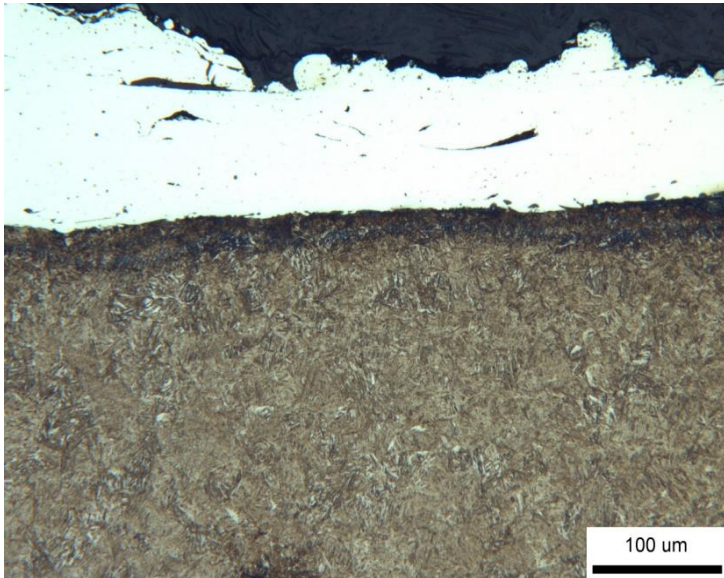

Figure.92. ESD of Stellite 21 on 300M tempered @ 575°F- 6 ESD layers

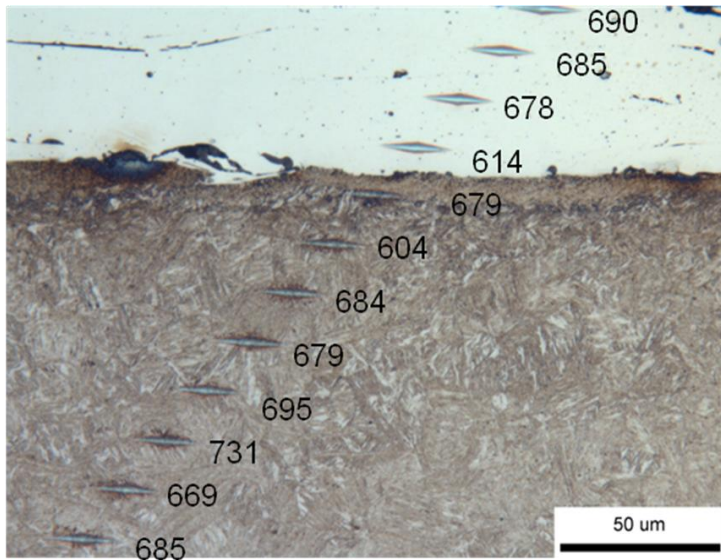

Figure.93.Knoop microhardness profile(25g-f load) for ESD on 575°F tempered 300M alloy

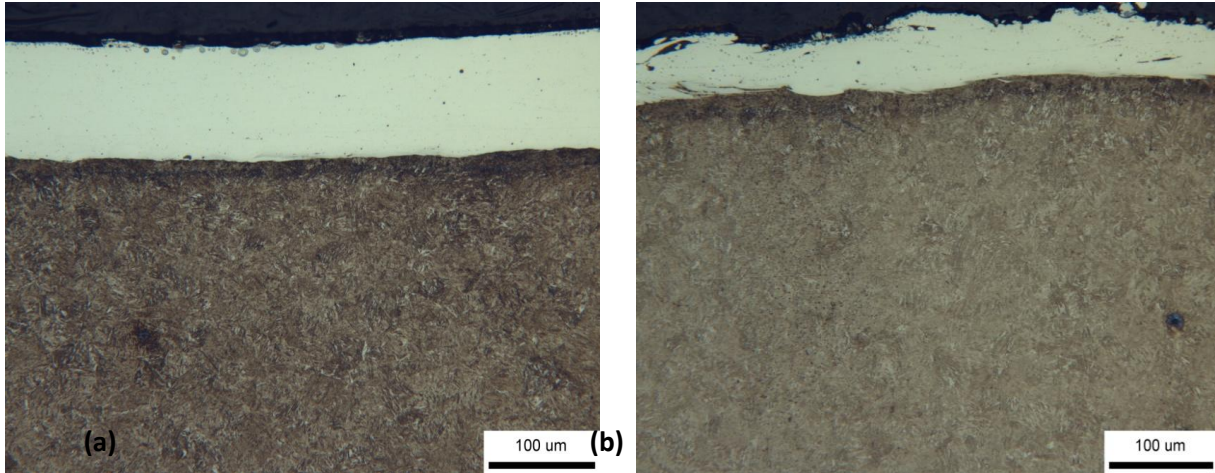

Figure.94. ESD of Stellite 21 on 575°F tempered 300M alloy (a) without UIT (b) with UIT

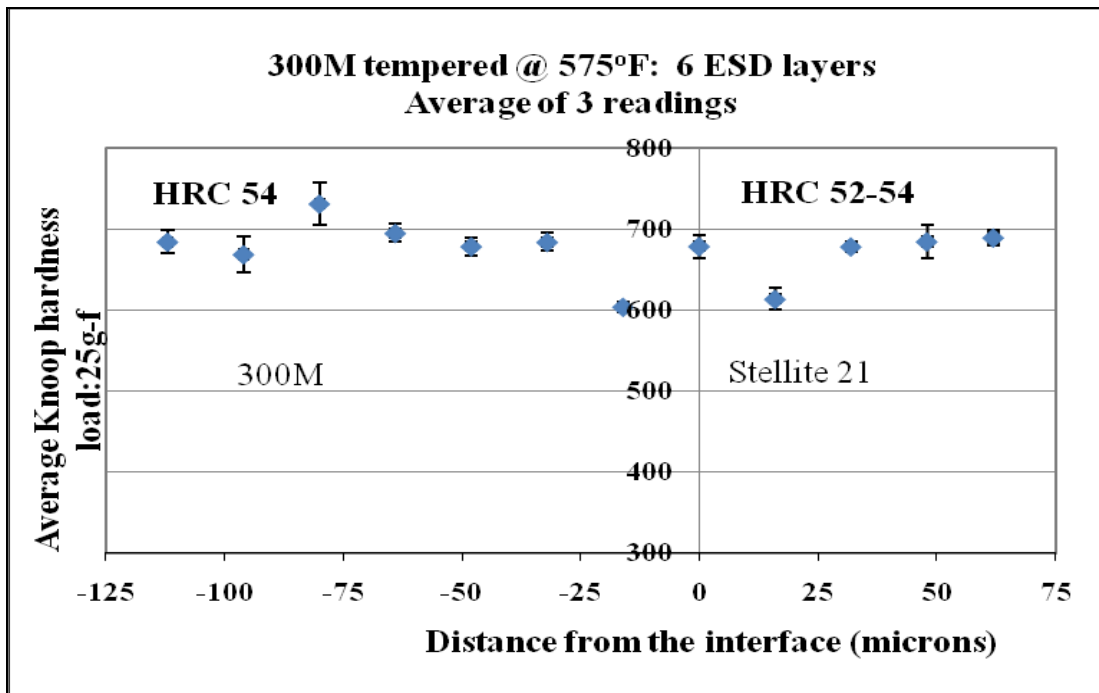

Figure 95. Hardness profile for ESD of Stellite 21 on 300M alloy tempered @ 575°F

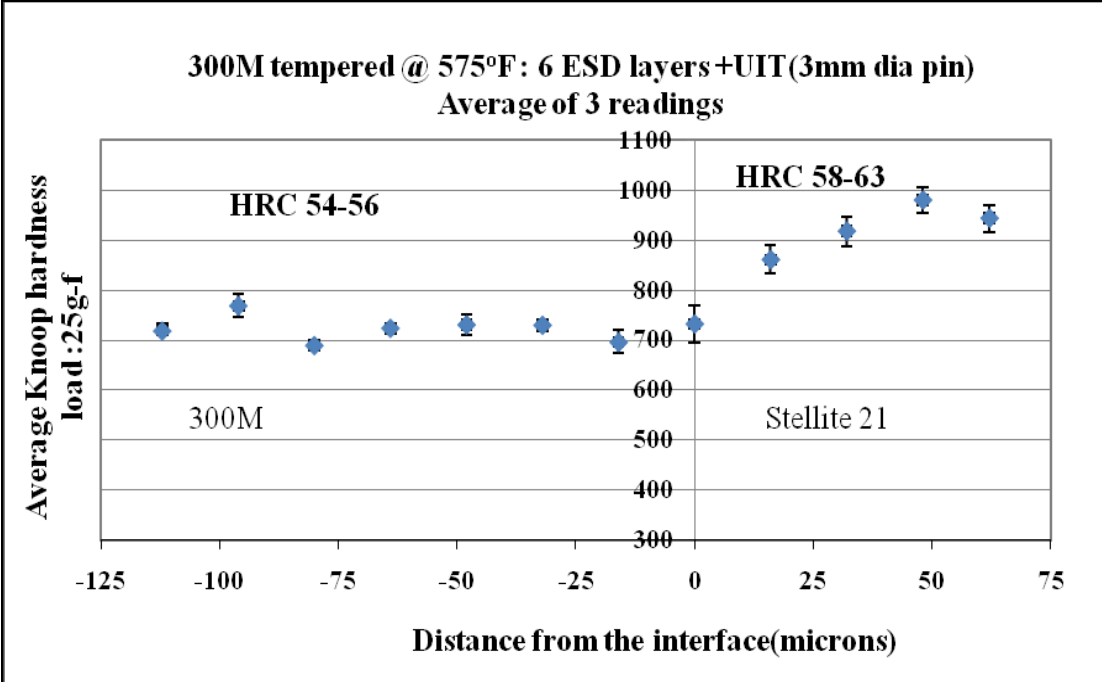

Figure.96. Application of UIT after ESD of stellite 21 on 575°F tempered 300M alloy

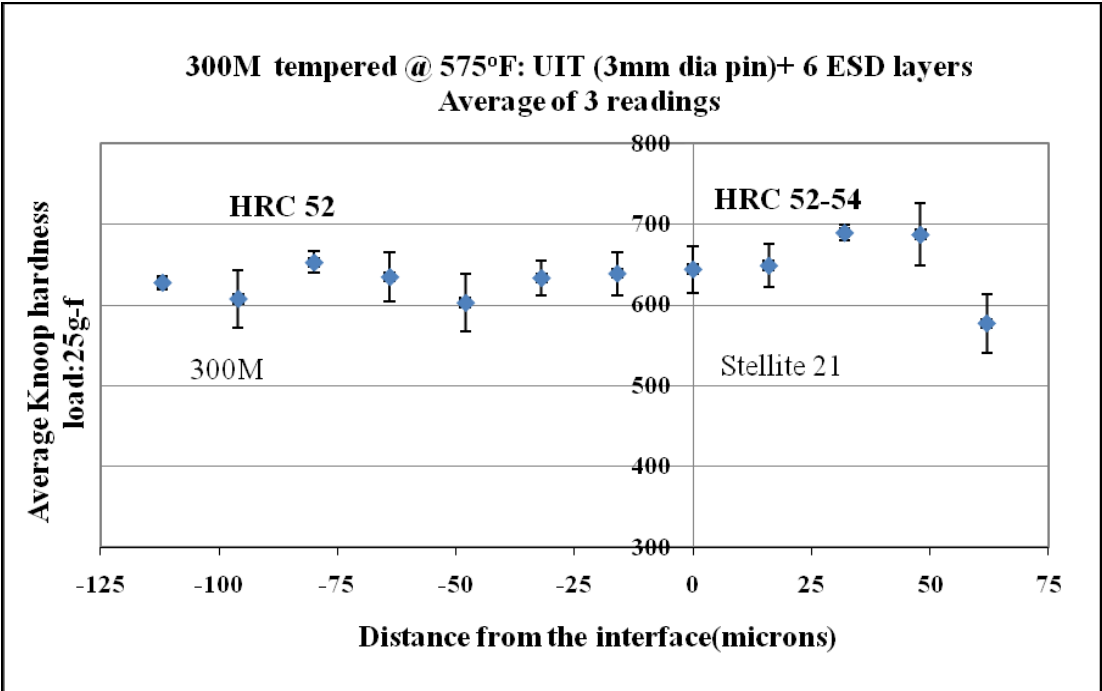

Figure.97. ESD of stellite 21 on UIT treated 300M alloy tempered @ 575°F

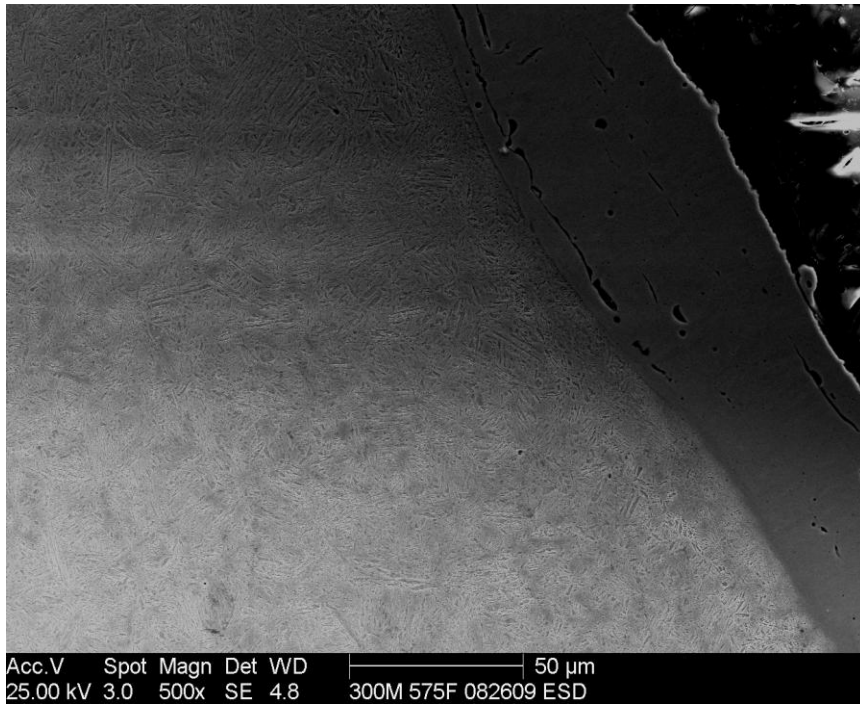

Figure.98. SEM cross section image of ESD of stellite 21 on 575°F tempered 300M alloy

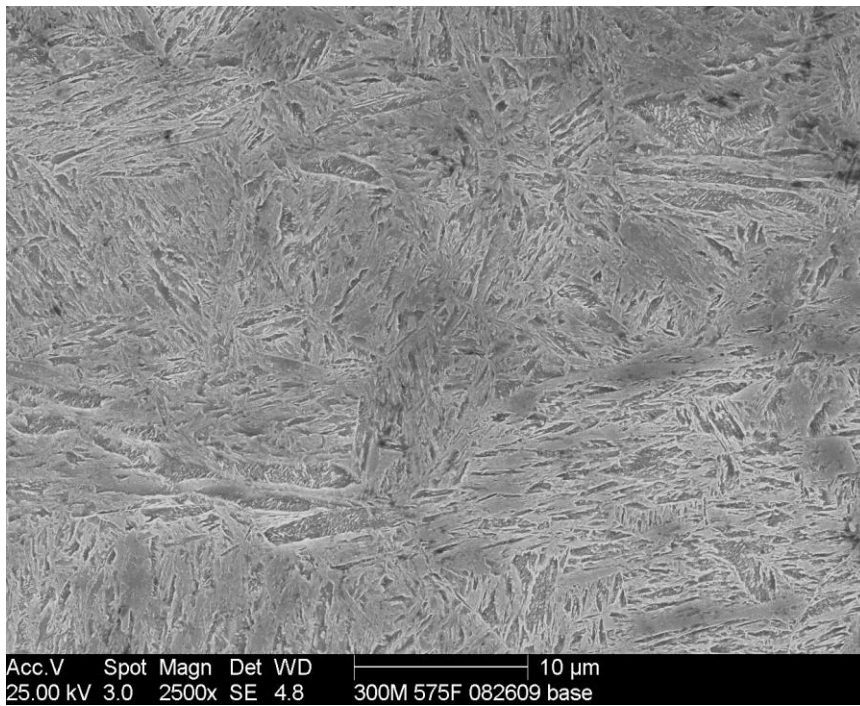

Figure.99. SEM cross section image of base material for 575°F tempered 300M alloy

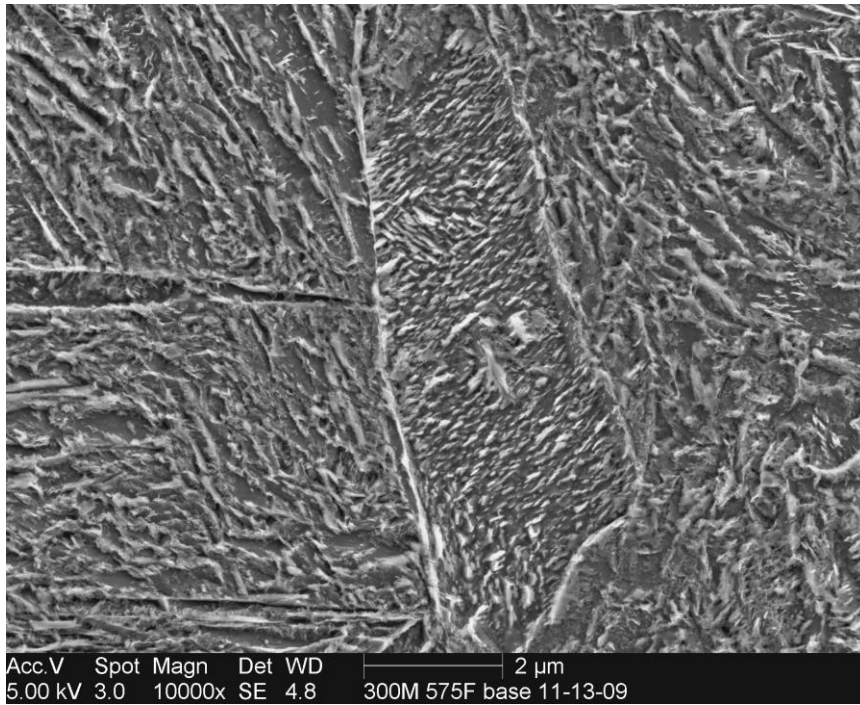

Figure.100. SEM cross section image of base material for 575°F tempered 300M alloy showing carbide precipitates-10000X

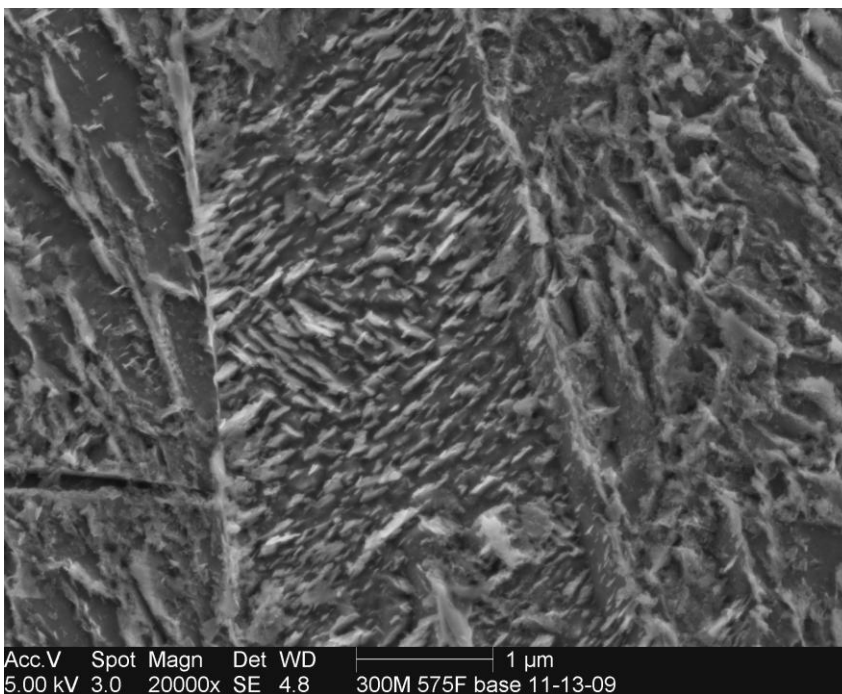
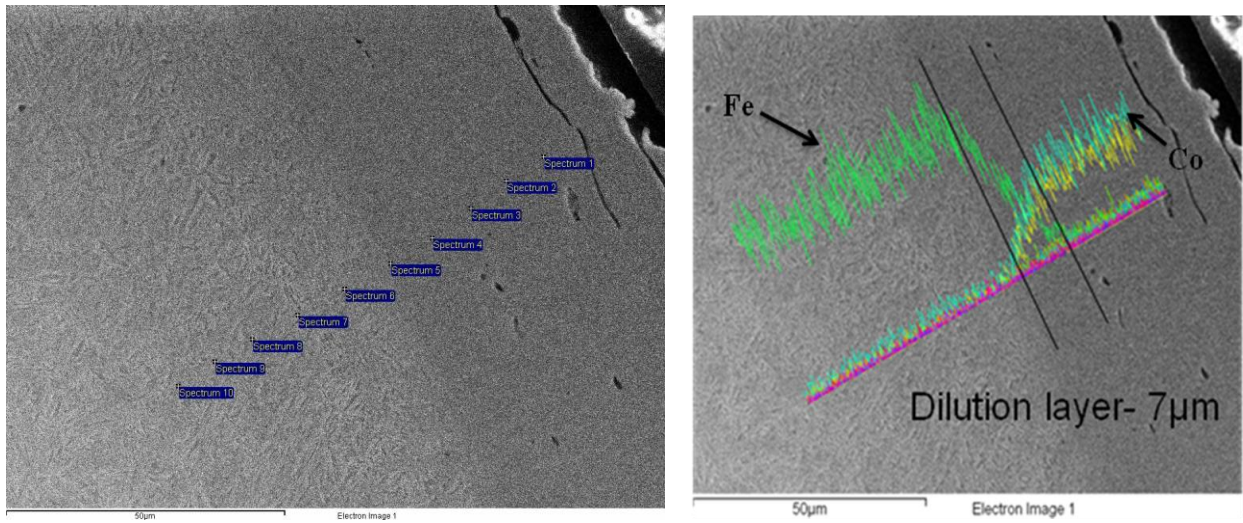

Figure.101. SEM cross section image of base material for 575°F tempered 300M alloy showing carbide precipitates-20000X



Element	Silicon	Vanadium	Chromium	Iron	Cobalt	Nickel	Molybdenum
Stellite 21	0.78	0.05	27.57	2.79	55.76	2.59	5.2
Spectrum 2	0.67	0.04	27.27	2.49	56.26	2.39	4.71
Spectrum 3	0.77	0.0	25.4	2.99	54.59	2.36	4.19
Spectrum 4	0.76	0.0	22.27	14.21	46.99	2.63	3.31
Spectrum 5	1.16	0.09	4.44	79.85	7.24	1.91	0.16
Spectrum 6	1.4	0.17	1.16	92.31	0.01	1.74	0.3
Spectrum 7	1.61	0.1	0.92	91.5	0.03	2.0	0.0
Substrate	1.48	0.2	0.97	92.5	0.06	1.71	0.0

Figure.102. EDX spectrums and line scans of ESD on 575°F tempered 300M- 6 ESD layers

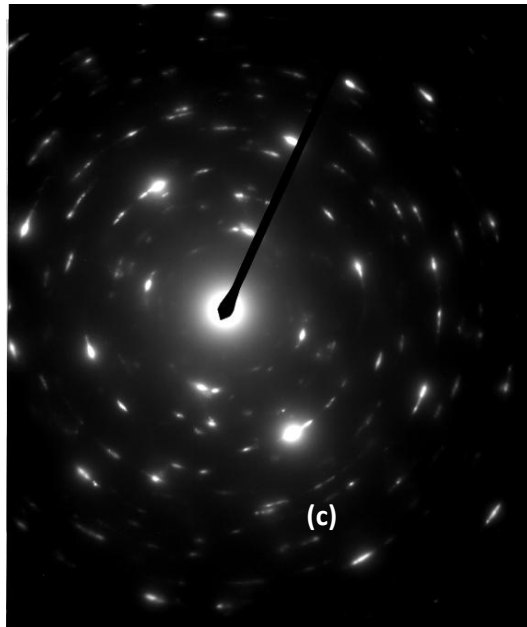
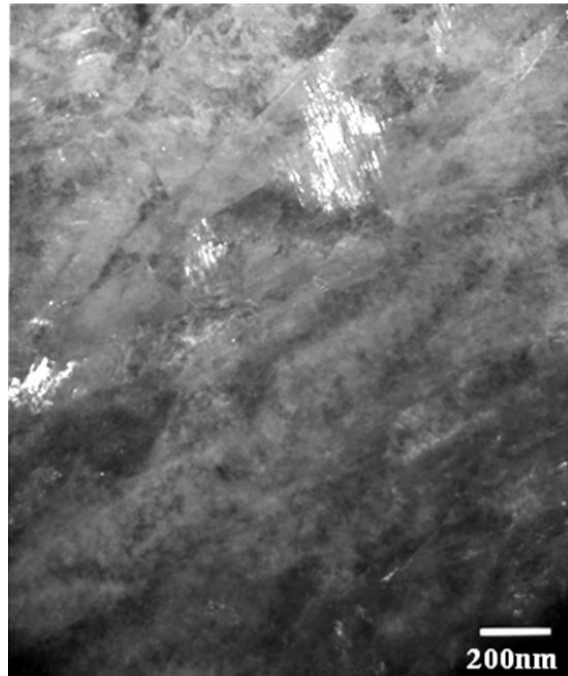
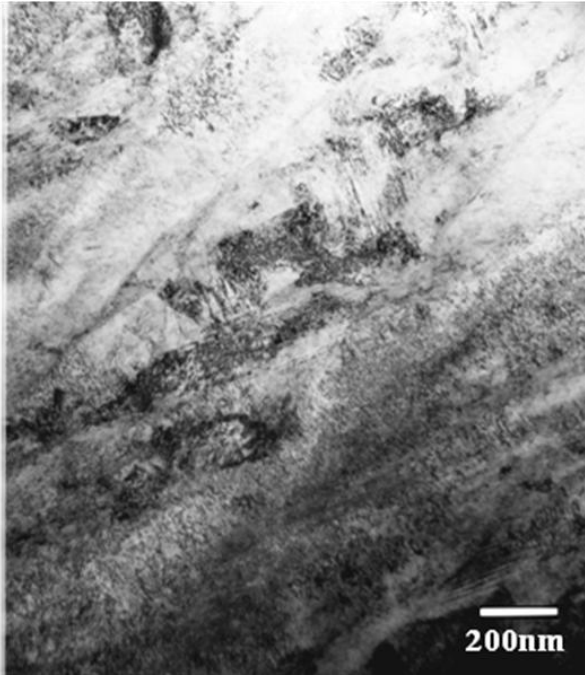

Figure 103: TEM micrograph of carbide precipitates in 300M substrate tempered at 575°F (a) bright field image (b) dark field image (c) SADP – no ESD/UIT treatment

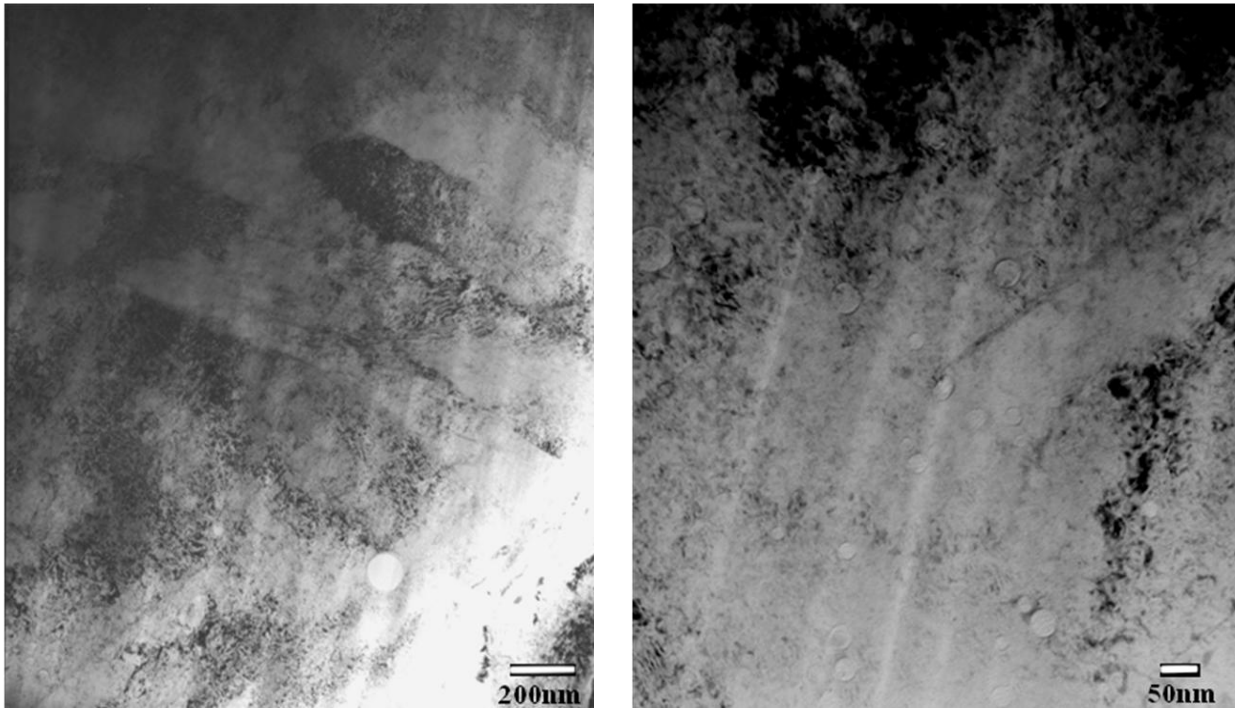

Figure 104: TEM bright field image showing voids in the stellite 21 deposit- ESD treated

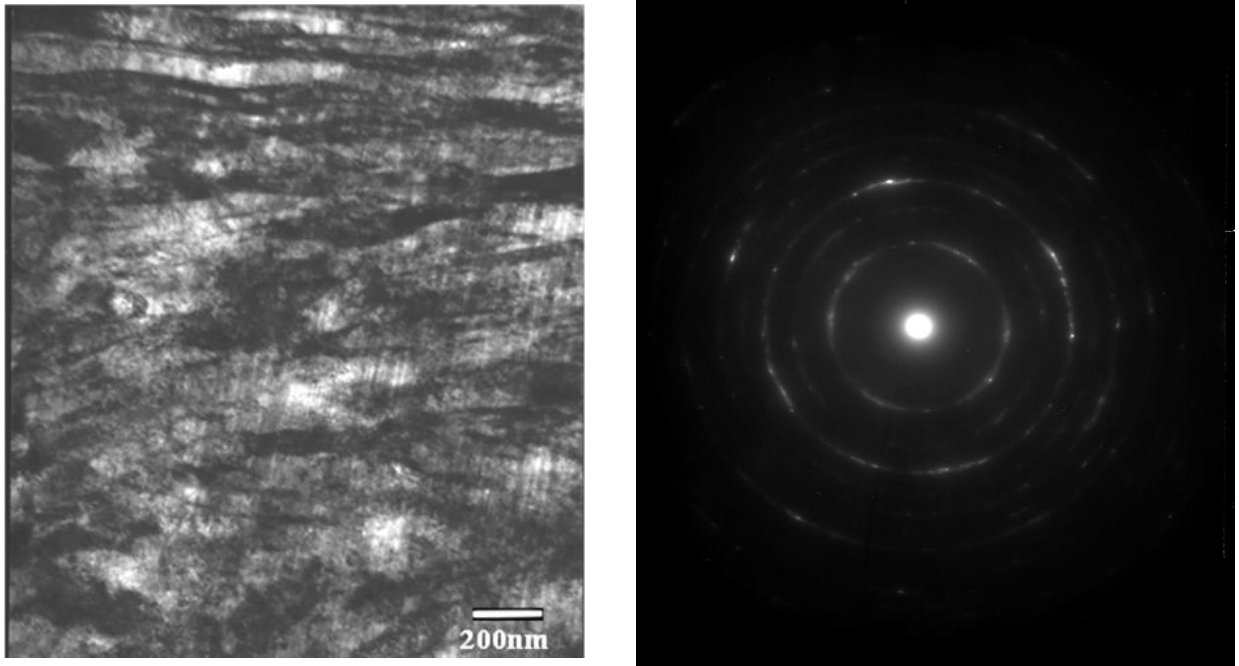

Figure 105: TEM micrograph of HAZ in 300M tempered at 575°F- ESD treated

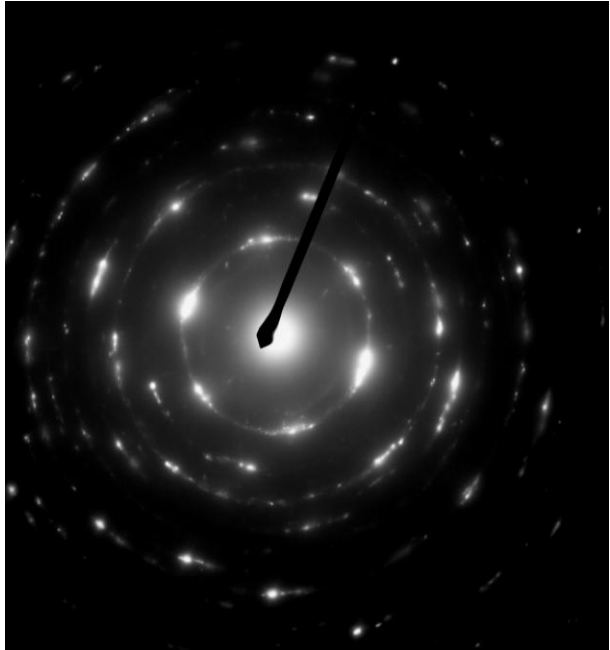
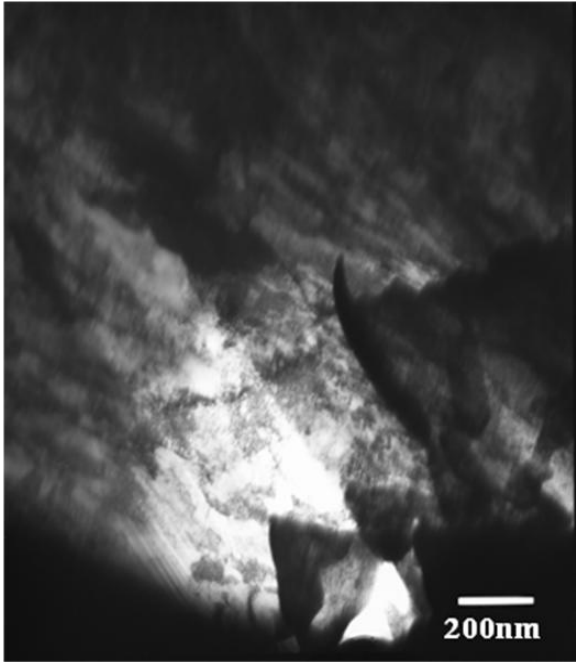

Figure 106: TEM image of 300M Substrate tempered at 575°F- ESD+UIT treated

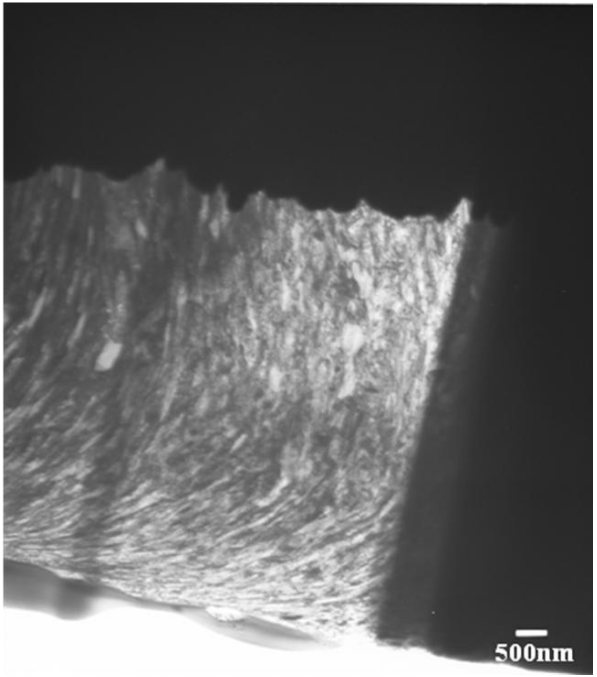
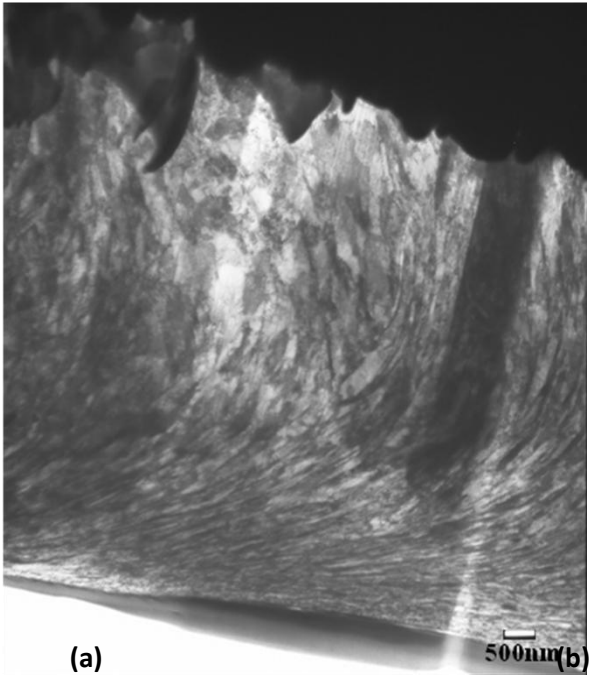

Figure 107: TEM micrograph of ESD+ UIT treated (a) 300M Substrate (b) Stellite 21 deposit

Ferrium S-53

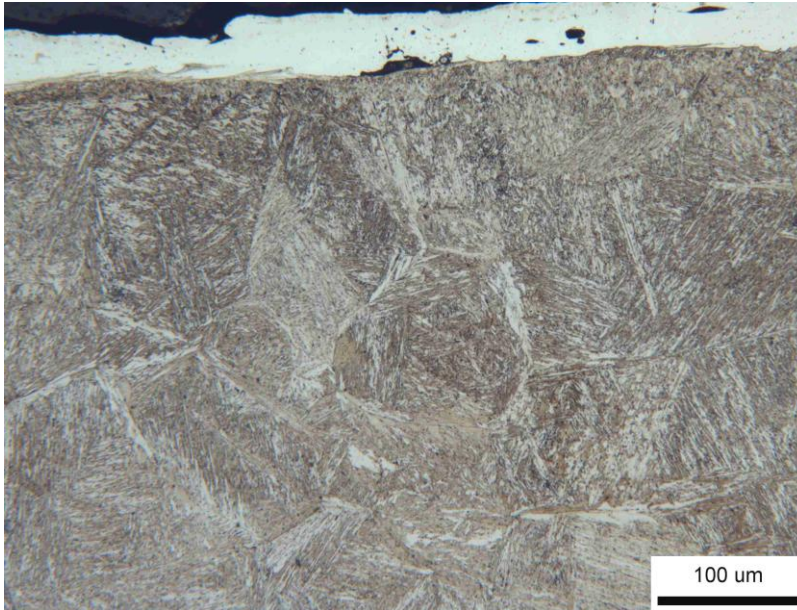

Figure.108. ESD of stellite 21 on aged Ferrum S-53 alloy- 6 ESD layers

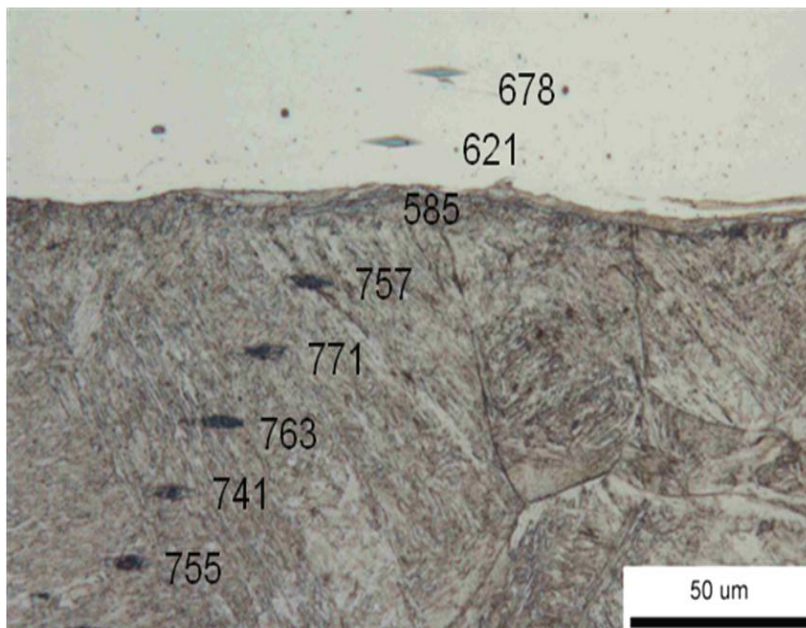

Figure .109. Knoop microhardness profile(25g-f load) of ESD on aged Ferrum S-53 alloy

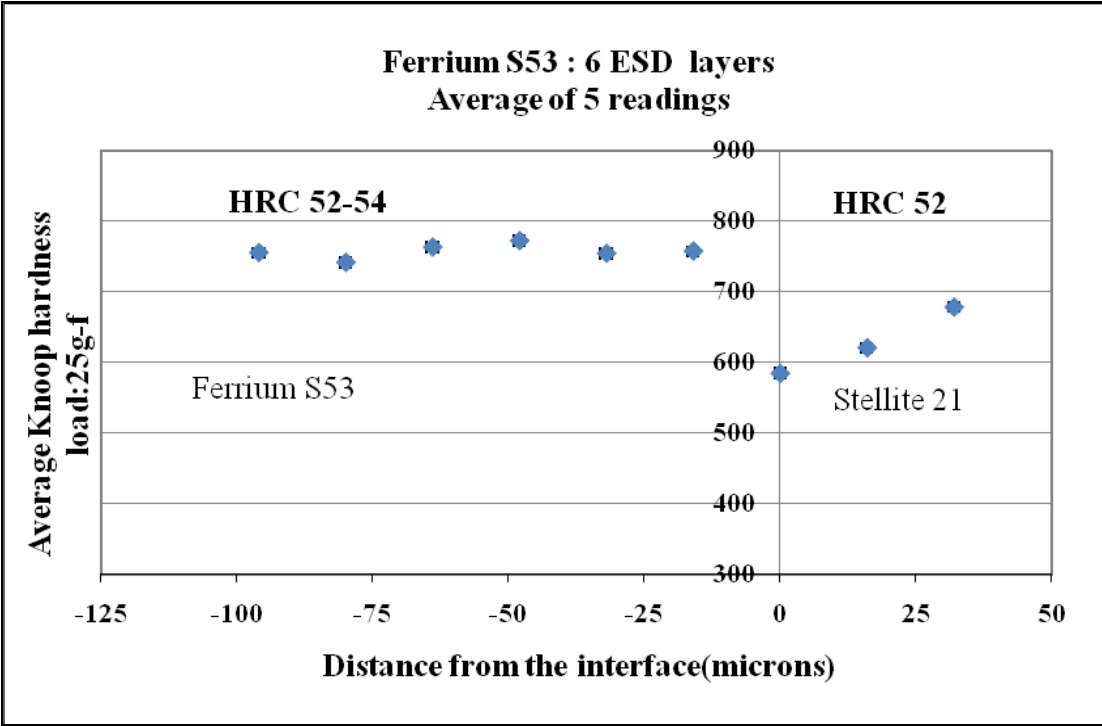

Figure 110. Hardness profile for ESD of Stellite 21 on aged Ferrium S-53 alloy

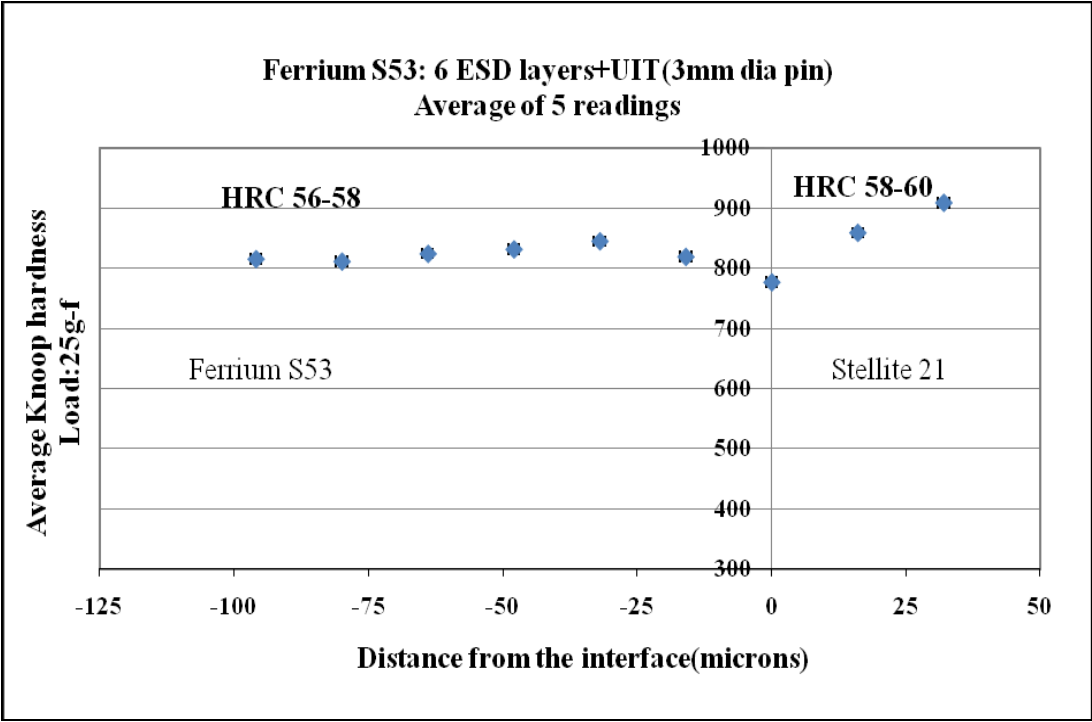

Figure.111. Application of UIT after ESD of stellite 21 on aged Ferrium S-53 alloy

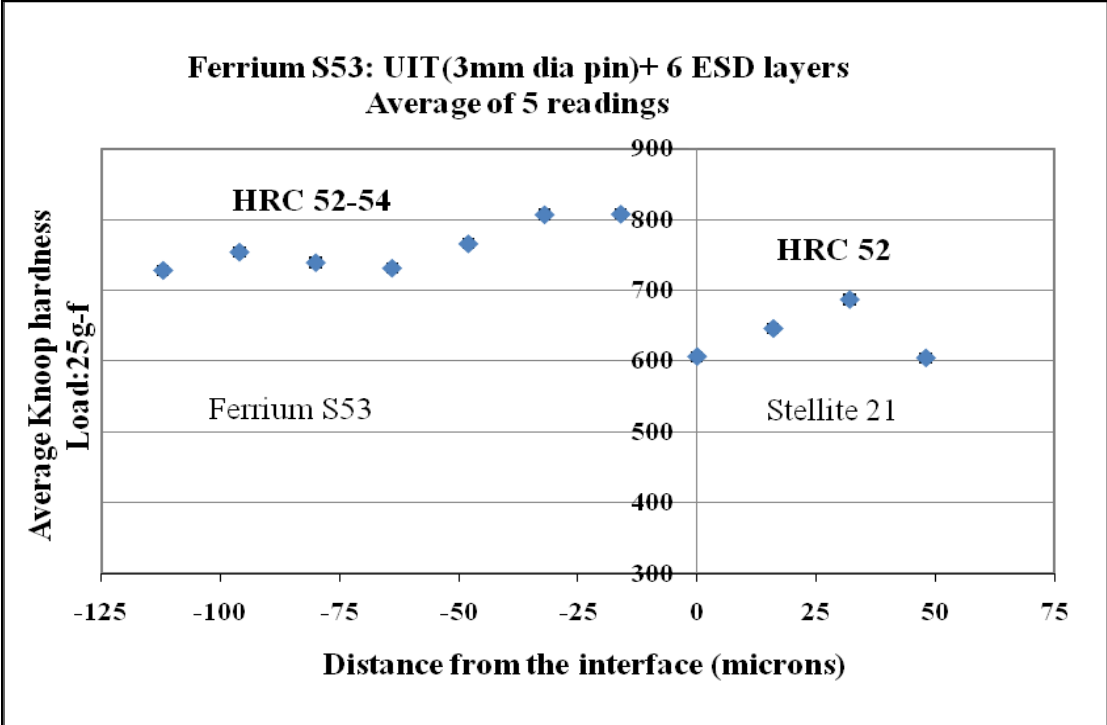

Figure.112. ESD of stellite 21 on UIT treated Ferrium S-53 alloy tempered at 934°F and 900°F

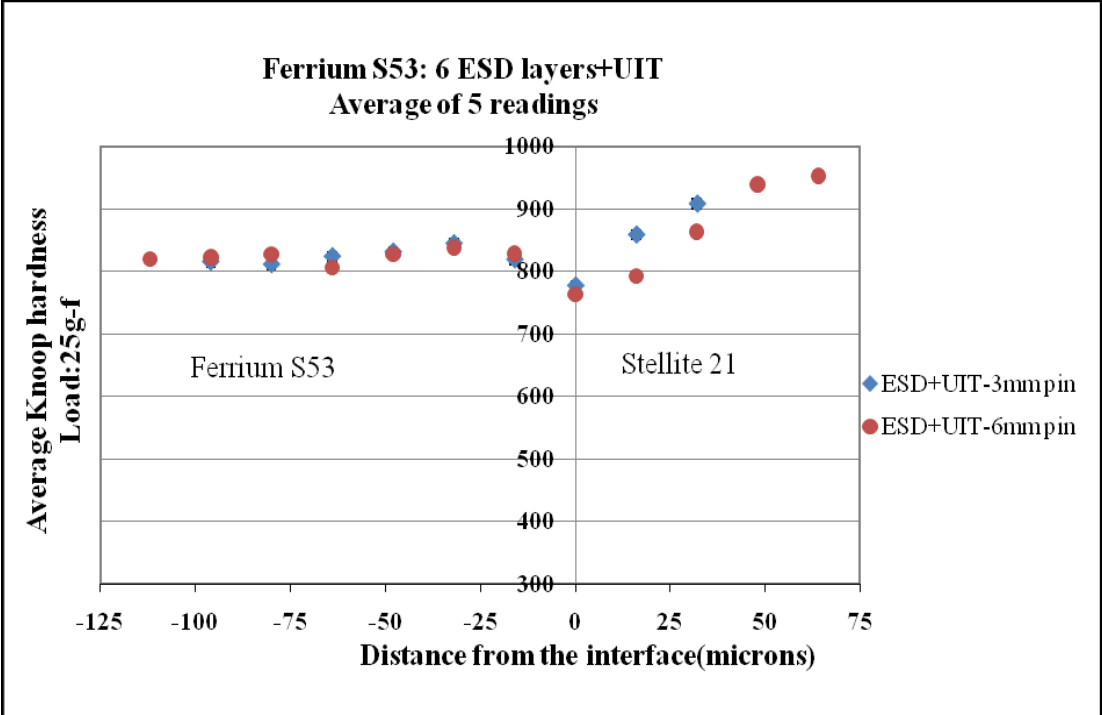

Figure.113. Hardness depth profile for ESD +UIT on tempered Ferrium S-53 alloy with two UIT pin sizes

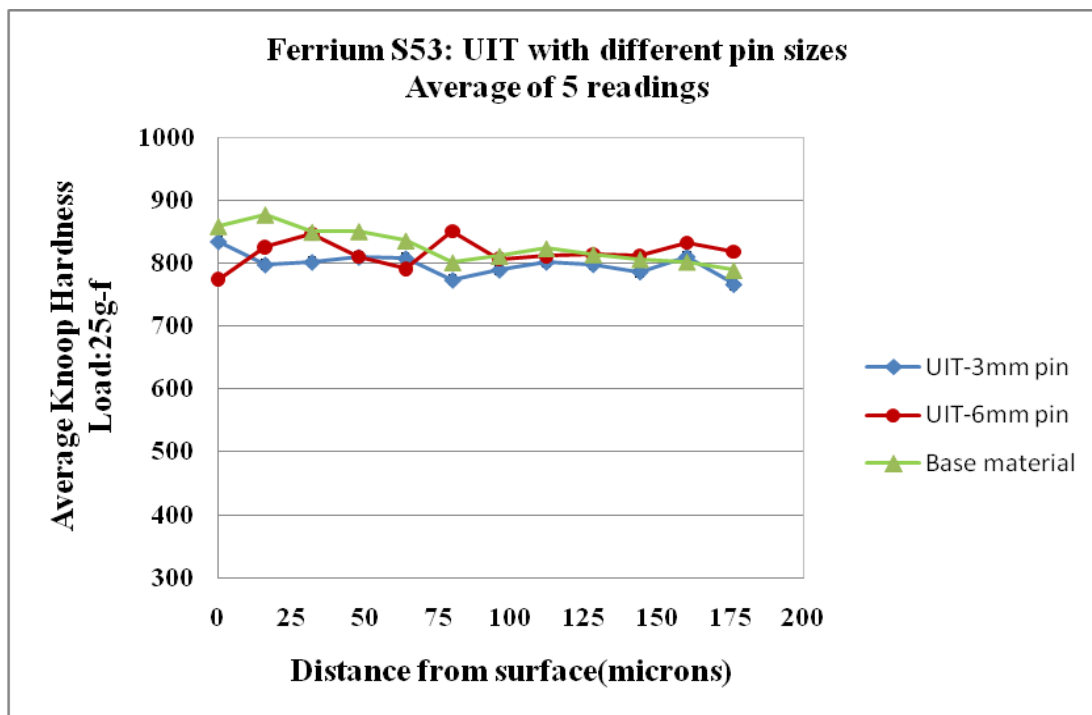

Figure.114. Hardness depth profile for UIT on aged Ferrium S-53 alloy with two UIT pin sizes

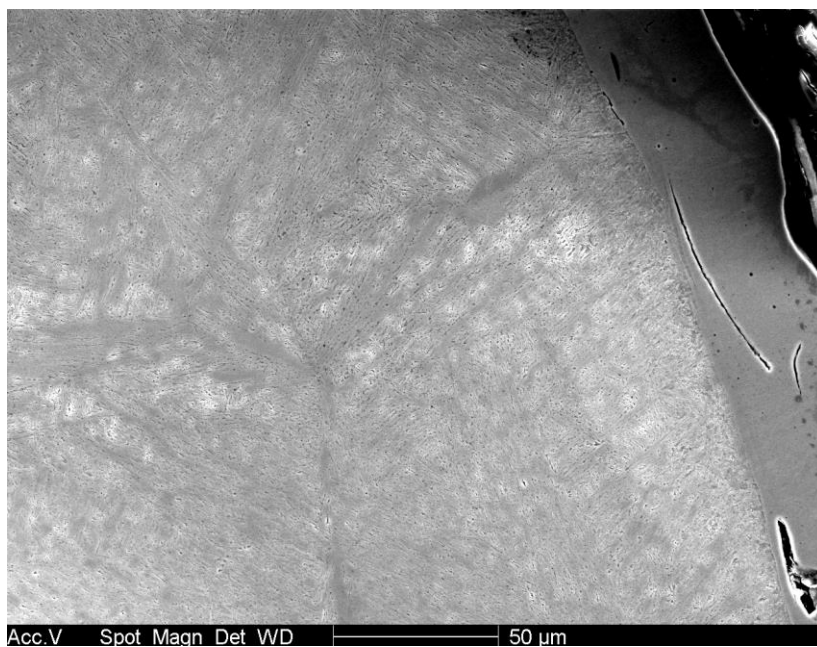

Figure.115. SEM cross-section image of stellite 21 on Ferrium S-53 alloy tempered at 934°F & 900°F

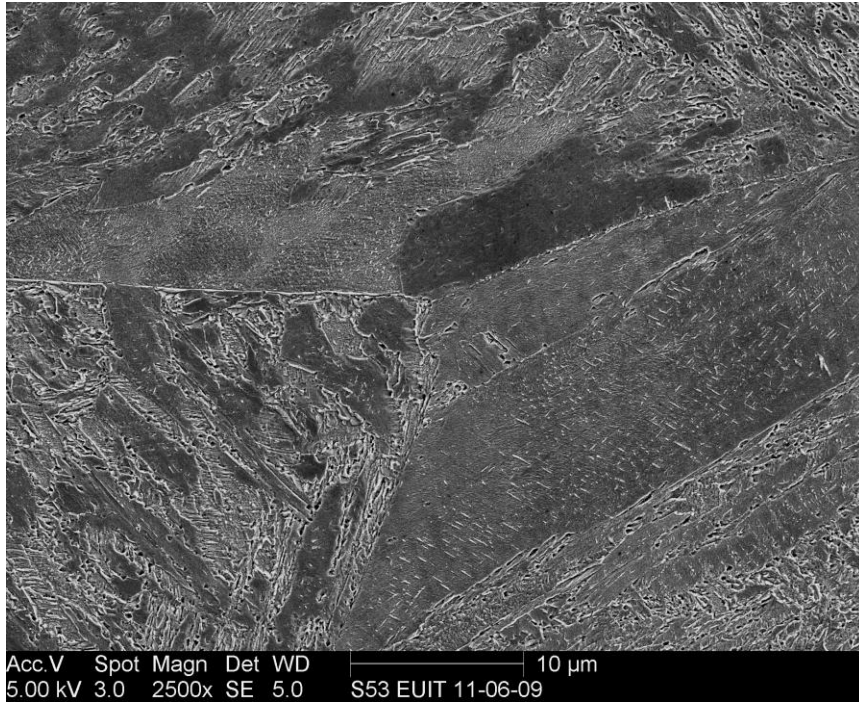

Figure.116. SEM cross section image of base material Ferrium S-53 alloy aged at 934°F & 900°F

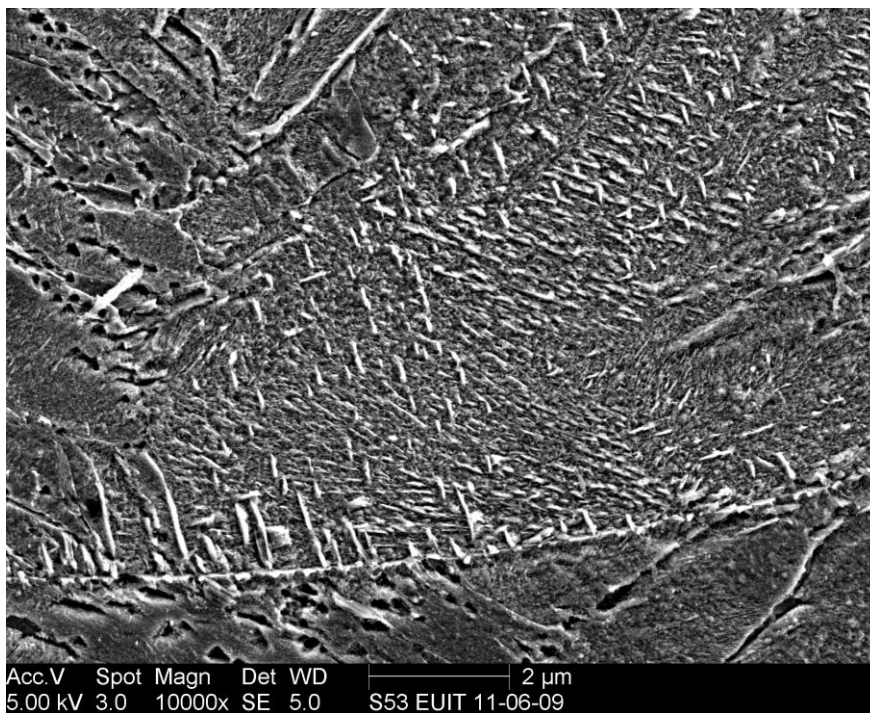
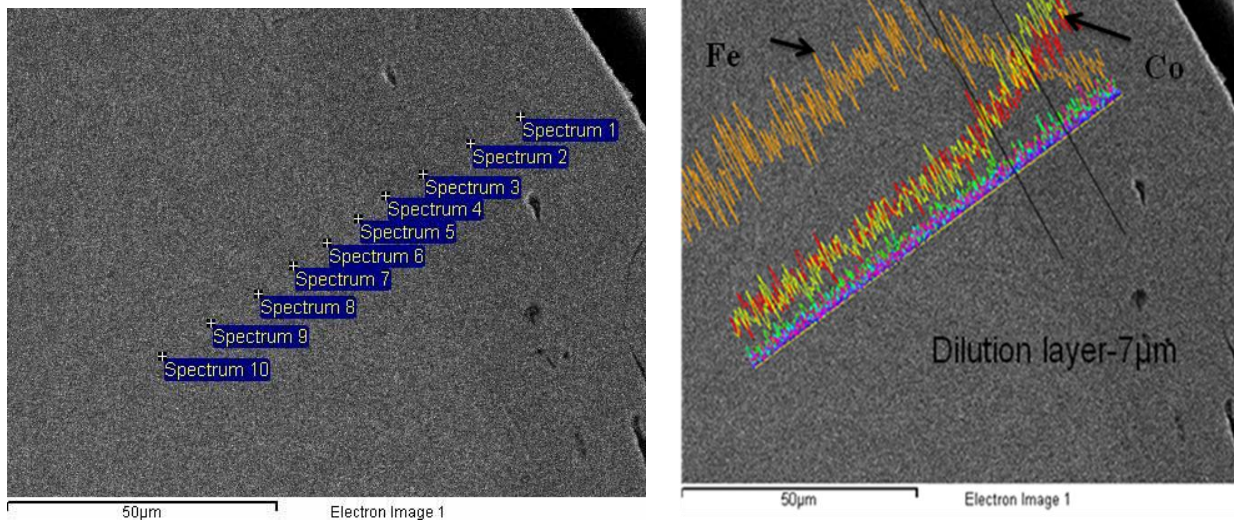

Figure.117. SEM cross section image of base material Ferrium S-53 alloy tempered at 934°F & 900°F showing carbide precipitates



Elements	Silicon	Chromium	Iron	Cobalt	Moly	Nickel	Tungsten
Stellite 21	0.51	23.84	13.86	49.15	4.49	3.05	0.13
Spectrum 2	0.53	22.33	18.18	45.89	4.41	3.72	0.30
Spectrum3	0.19	17.60	36.53	33.25	3.33	4.40	0.25
Spectrum4	0.00	10.89	62.55	14.46	2.10	5.37	0.97
Spectrum 5	0.00	10.59	65.43	13.56	2.02	5.99	0.54
Spectrum 6	0.10	10.35	64.53	13.15	2.44	5.64	1.07
Substrate	0.04	10.46	65.29	13.43	1.89	5.67	1.07

Figure.118. EDX spectrum analysis and line scans of ESD on aged Ferrium S-53 alloy- ESD 6 layers

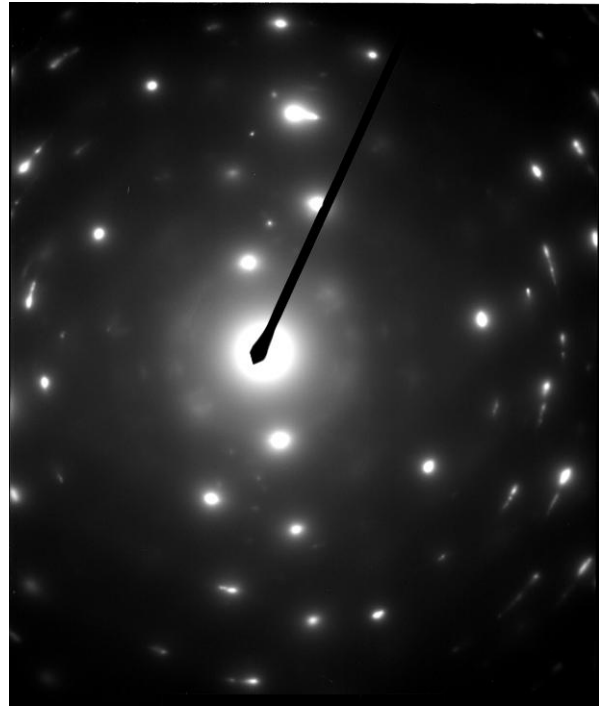
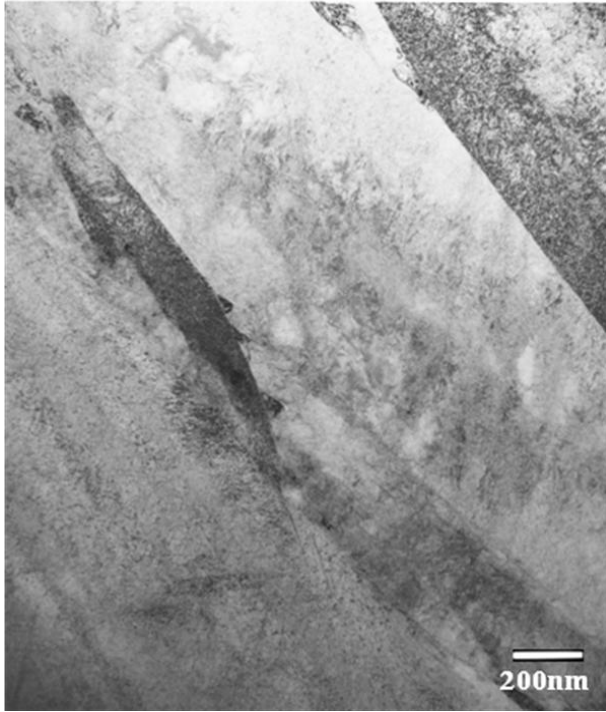

Figure 119: TEM micrograph of base material Ferrium S-53 alloy tempered at 934°F and 900°F –no ESD/UIT treatment

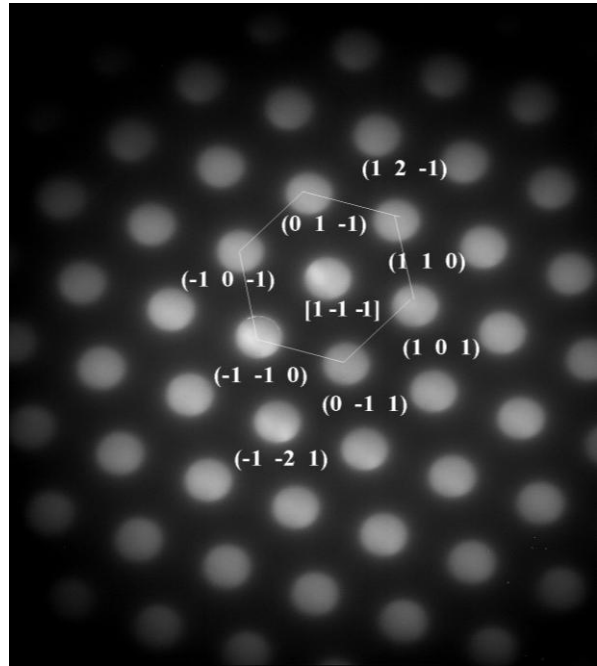
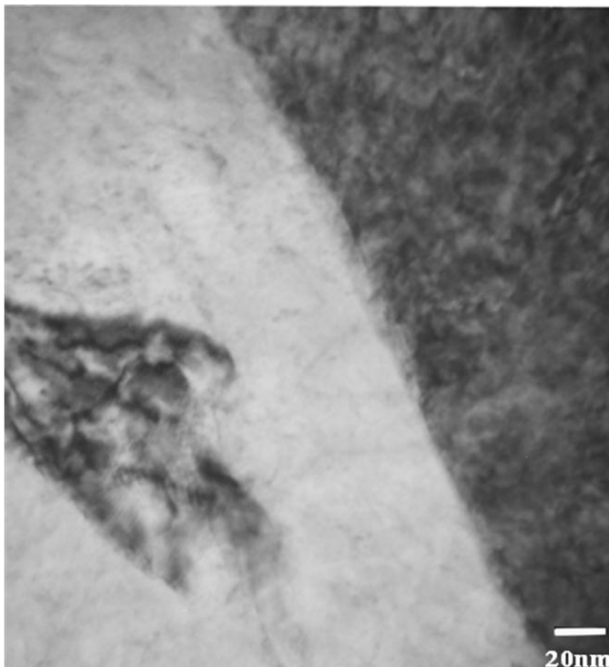

Figure 120: TEM micrograph of lath boundary in base material Ferrium S-53 alloy tempered at 934°F and 900°F –no ESD/UIT treatment

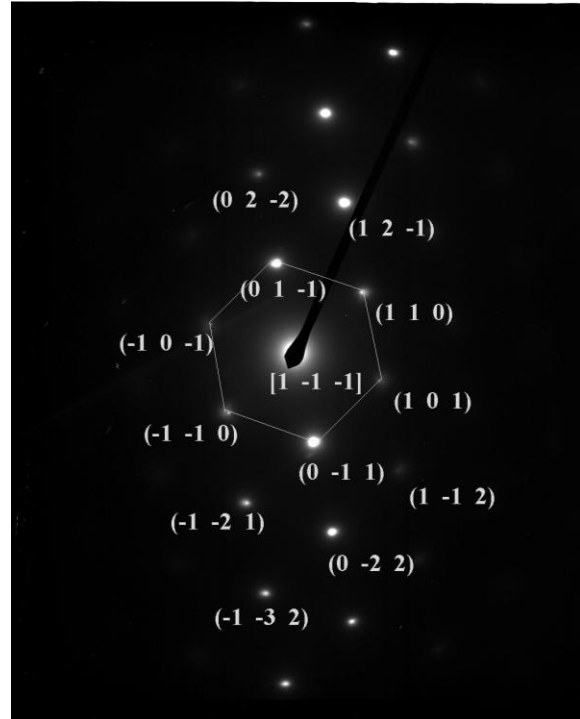
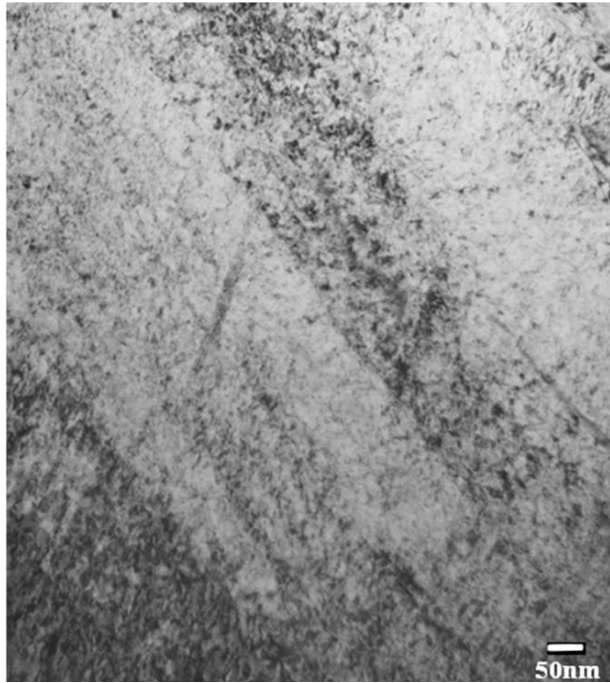

Figure 121: TEM micrograph of carbide precipitates in base material Ferrium S-53 alloy tempered at 934°F and 900°F – no ESD/ UIT treatment

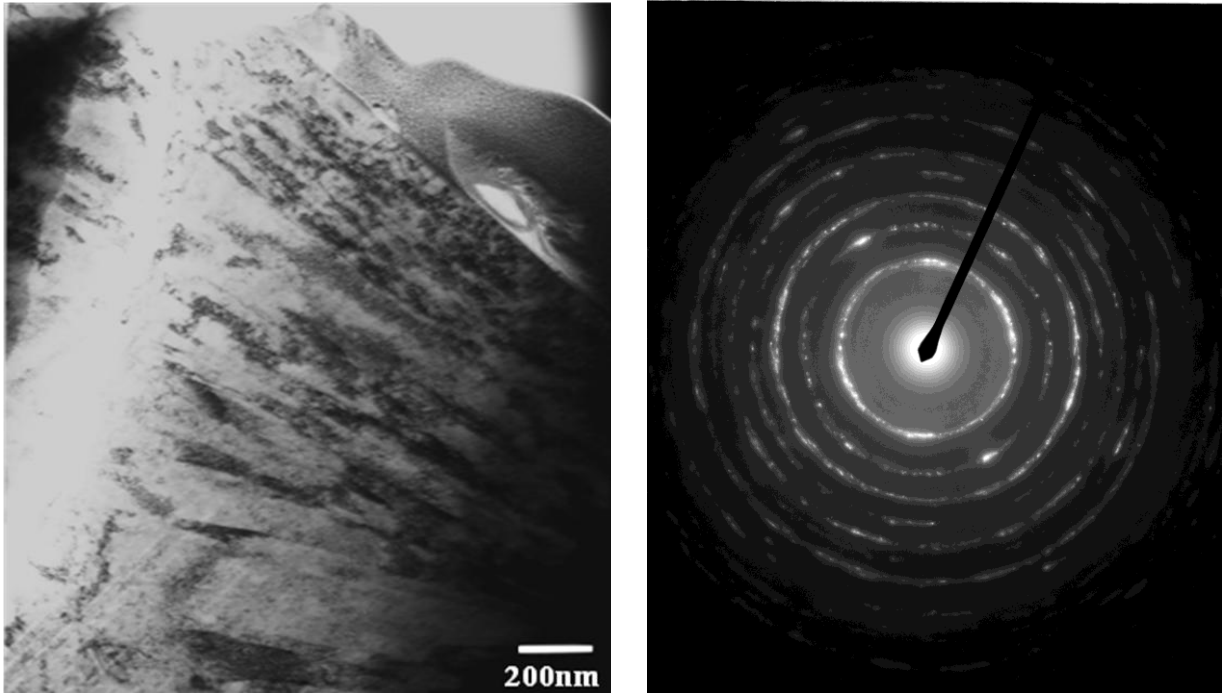

Figure 122: TEM micrograph of Ferrum S-53 substrate tempered at 934°F and 900°F – ESD+UIT treated

PART B

B1. INTRODUCTION:

Ultrahigh strength steels, yield strengths greater than 175 Ksi can be divided into several categories; low alloy quench and tempered martensitic steels (UHSLA), high alloy secondary hardened steels, and low carbon precipitation/aged strengthened steels. Detailed studies have been carried out for many years to improve the toughness of these steels, without affecting the strength. A variety of heat treatments have been employed which alters the basic microstructure in such a way to get the best combination of strength and toughness. However, only limited success has been achieved in producing low alloy steels with the combination of high strength, ductility and toughness. Additionally corrosion and hydrogen embrittlement induced cracking protection historically requires electroplating.

Since 1960 the 300M steel (the AISI 4340 modified by much higher content of Si) has been preferentially used in the US military and in industry for the landing gears on the space shuttle as well as on many commercial aircrafts. About 33% of the aircrafts accidents are due to landing gear failures. Two main failure mechanisms are stress corrosion cracking (SCC) and hydrogen embrittlement (HE). SCC which is usually caused by the interaction of stress either applied or residual stresses accompanied by aggressive environment are particularly severe for high strength steels and are extremely susceptible even under very mild environments with very low hydrogen content (less than a few parts per million). Although many investigators have made efforts to improve general properties (strength, toughness, ductility) of these steels, improvements in H.E. and SCC threshold stress corrosion cracking stress intensities have not been significant. Electroplating and shot peening type surface treatments are only partly effective. New high strength aerospace alloys like Carpenter Custom 465 and Ferrium S53 are designed to offer a unique combination of high strength, toughness and to provide corrosion resistance. In part B of this program, mechanical property, fatigue crack growth rate, stress corrosion cracking resistance and microstructural studies have been investigated for the conventionally used 300M newly developed C465, S53 alloys. 300M served as the benchmark alloy.

B2. EXPERIMENTAL METHODS:

a. Materials and Sample Preparation:

The materials were received in the laboratory forged condition from Carpenter Technology in the form of approximately 2.75inches x 3.25inches x 48inches long sections with a forging reduction of between 5.5 and 6. Plane strain fracture toughness compact tension specimens (CTS), Charpy, fatigue and tensile specimens were machined from the plate such that the notch orientation was transverse to the forged length. Dimensions are shown in Figure 1 per ASTM E399 and E23. The CT specimens were also used for crack growth rate, stress corrosion cracking and acoustic emission (AE) studies.

b. Heat Treatment:

Alloy 300M was heat treated at Met-Tek Inc, a commercial heat treating facility. Custom 465 was received in the solution treated, water quenched and refrigerated to -100°F condition. All machining operations for all samples, except the CTS notch, were completed before vacuum aging at either 950°F or 1000°F. The CTS notch was made using the EDM process. Ferrium S53 was received in the annealed condition. After sample machining S53 was vacuum solution treated and double aged according to Carpenter Technology's specified heat treat schedule for S53 by Stack Metallurgical, a commercial aerospace heat treating facility. Detailed heat treatment schedules are provided in Table 2.

c. Mechanical Property Evaluation:

Plane Strain Fracture Toughness Testing:

All plane strain fracture toughness tests were carried out at room temperature using ASTM specified compact tension test specimens according to specification E399. All specimens were 0.70 in thick and were tested in the longitudinal direction. Specimens were machined to final dimensions prior to heat treating except for the starter slot. This was added after heat treating by electrospark discharge machining, EDM and resulted in a sharp fatigue precrack starter notch to facilitate development of the fatigue precrack. A 200,000 lb capacity 4 column Instron servohydraulic test system, model 1335 equipped with a 100,000lb load cell was used for all testing, including fatigue pre-cracking at 9 Hz. All fatigue cracks were fatigued at least 0.1 in from notch and fatigue loads were kept within ASTM recommendations. Fracture toughness testing was carried out at a cross head speed of 0.02in/min.

Impact Toughness Testing

A standard full size ASTM-E23 Charpy-V-Notch (CVN) impact specimen geometry used in the present study, (0.394 x 0.394 in² cross section). All specimens were machined to final dimensions prior to heat treatment, except for the V-notches that were ground after the final heat treatment. All impact tests were carried out using a 264 ft-lb capacity Tinius Olsen pendulum type machine. CVN tests were conducted over a temperature range of +100°C to -60°C. Low temperature test samples were held in a NESLAB ultra low temperature bath. For elevated temperature testing, specimens were immersed in a heated water bath.

Tensile Testing:

Room temperature longitudinal tensile properties were determined using a 1 inch gauge length, 0.250 inch diameter ASTM-E8 specified round specimen. Detailed dimensions are shown in Figure 1. Machining was done prior to vacuum heat treatment. The same 100,000 lbs capacity Instron Lawrence dynamic test machine was used to test the specimen at a loading rate of 0.1in/min.

Fatigue Crack Growth (FCG) Testing:

CT type specimens were used to study fatigue crack growth rate as a function of stress intensity. A 4 column 200,000lbs capacity loading frame with a 100,000 lbs capacity load cell Instron model 1335 dynamic test system was used for all FCG tests. The test was performed under stress intensity control in tension-tension cycling using a sinusoidal waveform at a frequency of 9 Hz and at a stress ratio of 0.1. All the specimens were tested in laboratory air at room temperature. The Instron da/dn Fatigue crack propagation FastTrack software program was used to run all tests. The fatigue loading procedure was K-decreasing in the stable and in the near threshold FCG region and K-increasing in the higher delta K region leading to rapid unstable crack growth. This testing was done according to specification ASTM E 647.

Stress Corrosion Cracking (SCC) Testing:

For the Stress corrosion cracking test, an accelerated test method, rising step load (RSL) was employed. This test is done according to specification ASTM F1624-05 using CT specimens in the longitudinal direction. Tests were carried out at room temperature. A 100,000 lb capacity Instron servohydraulic dynamic test system was used for all SCC tests. CT specimen pin type loading fixtures per ASTM E399 were held rigidly in the test system using hydraulic grips. Figure 2 shows the test setup configuration. The specimen notch with a fatigue pre-crack was surrounded by the salt water reservoir and the reservoir was fixed to the bottom fixture and sealed with an O-Ring to avoid leakage. The Instron fast track 8800 controller interfaces the loading frame and the computer operating software. A tension profiler test method in the blue hill software was used to create multiple blocks, programmed in such a way that the specimen is held at predetermined load steps for a designated time and then incrementally ramped to next higher load level until crack growth is detected by the load drop while the displacement was held constant.

The following steps outline of the test procedure:

1. All the specimens were fatigue precracked to the same length at a frequency of 9Hz before testing.
2. The specimen max load to failure, P_{max} , was determined from the plane-strain fracture toughness tests.
3. For $\pm 5\%$ accuracy, divide P_{max} into 20 equal steps and these equal load increments shall be used in step loading program under displacement control. Displacement-load relationships were determined using compliance relationships.
4. The software step loading program was created to attain P_{max} under displacement control in such a way that each sample was held for the predetermined time for every load step.
5. Load the specimen in the testing apparatus.
6. An Acoustic Emission sensor was attached to the specimen using a small amount of vacuum grease to ensure good coupling between sensor and specimen.
7. A pencil lead with 0.5mm lead was broken on the sample, to ensure an 80dB minimum AE amplitude was recorded.
8. Add the 3.5% aqueous NaCl solution to the reservoir surrounding the CT sample.
9. The test was initiated (hold time is 1 hour initially in each load level) and the load necessary to initiate subcritical crack growth was determined by recording a significant load drop which is designated as P_{i1} .
10. Specimen 2 was loaded similar to the first sample using same load increment but doubling the hold time for each increment to 2 hours for each load step.
11. This loading sequence was continued until a significant drop in the load was detected and this value was designated as P_{i2} .
12. Similarly subsequent specimens were tested by continuing to double the holding time until an invariant value P_{th} is obtained.
13. The threshold stress intensity factor K_{Isc} for CT specimen was then calculated using the following relationship:

$$K_{Isc} = (P_{th} / BW^{1/2}) \cdot f(a_0/w)$$

Where

$$f(a_0/w) = (2+a_0/w) / (1-a_0/w)^{3/2} \{0.886+4.64(a_0/w)-13.32(a_0/w)^2+14.72(a_0/w)^3-5.6(a_0/w)^4\}$$

a_0 = original crack size

B = specimen thickness

W= specimen width

P_{th} = invariant crack initiation load

14. AE measurement analysis determined the change of AE total energy E with respect to time for each step load.

d. Acoustic Emission (AE) Analysis:

A multichannel computer based Vallen AMSY5 acoustic emission system was used to detect SCC induced crack growth. The AE system was also used to independently record load, and displacement data together with AE data. A block diagram of the A.E. monitoring system is given in Figure 3. A DECI SE650 P model sensor was attached, using a viscous couplant, to the CT specimen undergoing the stress corrosion test. This sensor is connected to the AE console (Vallen systems AMSY-5) channel 1 through 28vDC pre amplifier. Load, displacement channels are recorded by connecting the analog Instron output channels to the AE system parametric input channels. This allowed analysis of the AE response relative to load, displacement, and time.

e. Microstructural Studies:

Optical and Scanning Electron Metallography:

Specimens for optical microscopy were cut from CT specimens, hot mounted in Bakelite, then polished using an automated Struers Rotopol system to grind successively on 80, 220 grit abrasive and then polished using 9 μ m, 3 μ m and 0.04 μ m size silica particles suspended in water. These were then etched in 2% nital. These specimens were observed in Olympus PMG3 research optical microscope. Scanning electron metallography was done on samples prepared the same as for optical metallography. Examples are shown in part A figures, 22, 47,100,108, and 117 and are consistent with normal microstructures for these alloys. Alloy 300M prior austenite grain diameters were about 20microns, typical for quench and tempered 300M. Alloy C465 and S53 prior austenite grain diameters were about 100microns, larger due to the laboratory scale conversion from 8 inch diameter billets to the 3.75" x3.75 inch cross section supplied to PSU.

Scanning Electron Microscopy:

Scanning electron microscopy was used to examine fracture surfaces of toughness, tensile, and fatigue specimens. Fractured specimens were coated with a Krylon lacquer to protect them during wet abrasive sectioning. When ready for examination, the coating was dissolved in acetone and ultrasonically cleaned in methanol. For SEM microstructural studies, polished and etched specimens were used. All these specimens were examined in a FEI Sirion SEM under secondary electron accelerating voltages of 5 to 25 KV.

B3. RESULTS:

a. Mechanical Properties:

Toughness and Tensile:

Tables 3-5 summarize the mechanical properties for each alloy in each heat treatment condition. The heat treatment schedules are given in the table 2 and comparison of mechanical properties are shown in the Figure 4. For conventional 300M steel both tempering temperatures (400°F and 575°F) have similar ultimate tensile strength (UTS) and yield strength (YS), with a small increase in toughness by 5ksi-in^{1/2} with the increased tempering temperature. S53 showed similar fracture toughness values of around 55ksi-in^{1/2} when compared to 300M. Both UTS and YS are slightly lowered. C465 aged at 950°F and 1000°F showed much higher K_{1c} fracture toughness values compared to both 300M and S53. However for this steel there was a large decrease in both UTS and YS at the higher aging temperature. A 50°F increase in the aging temperature increased toughness from 80ksi-in^{1/2} to 120ksi-in^{1/2}.

Fatigue Crack growth rates:

Fatigue crack growth behavior is shown as log crack growth rate (da/dN) versus ΔK , Figure 5. The behavior is generally divided into three regions. Region I is the near-threshold region from which a threshold value ΔK_{th} is obtained, below which there is no observable crack growth. Above this value a very slow crack growth rate occurs with the increasing ΔK . Region II is more nearly linear, a steady-state region of the crack growth curve. Finally, in region III rapid and unstable crack growth occurs as final fracture is approached when K_{max} equals K_{1c} . In this study crack growth rates for each alloy were determined over a range of growth rates from 10⁻⁷ to 10⁻⁴ in/cycle. Results are shown in Figures 6 to 12. A summary plot of all data is shown in figure 12.

In the region I at very low stress intensity levels ($\Delta K < 10$ ksi-in^{1/2}) all of the crack growth rates were in the 10⁻⁷ in/cycle range. The threshold stress intensity range for 300M at either tempering temperatures was approximately 6ksi-in^{1/2}. The Ferritic S53 threshold was slightly increased to about 8 ksi-in^{1/2} equal to C464 aged at 1000°F. C465 aged at 950°F was shifted further to higher values increasing the threshold stress intensity range to approximately 12ksi-in^{1/2}. At intermediate ΔK values both 300M and S53 showed similar crack growth rates and also the highest values of da/dN when compared to C465. Although there was some variation in crack growth rates between these steels, the transition from region II crack growth to region III was strongly dependent on fracture toughness of the material. The region II crack growth was extended to higher stress intensity ranges in both aging conditions for C465 than in 300M and S53 because of C465 alloy's higher toughness. At high values of ΔK all the curves showed an increase in crack growth rates and as K_{max} was approached, the data correlate with K_{1c} values listed in Table3.

Stress Corrosion Cracking (SCC):

The rising step loading curves used to establish K_{1sc} for each of the three alloys are shown in figures 12 to 16. In each case the displacement steps were derived by dividing the K_{1c} fracture load into 20 steps, loading to the desired level and then transferring to a constant displacement control mode. Two intermittent issues were observed during these RSL tests carried out using the Instron Servohydraulic test system. Neither influenced the threshold stress corrosion cracking stress intensity value determined by the RSL. The first unexpected and unexplained behavior was that for the initial displacement steps the load usually increased and as the displacement step and corresponding increased load increased the load stopped increasing.

No satisfactory explanation was found to explain this trend, other than to suggest that it was somehow associated with the low load levels for these steps in conjunction with using a 100,000lb load cell. The second intermittent behavior was load fluctuation and occasionally displacement oscillation. These appeared to be independent of each other and are believed to be electronic load cell noise and intermittent actuator/servo valve induced oscillations. A smaller load cell and a smaller Moog servo valve (20gpm for the system used for these RSL tests) would be more optimal.

The rising step load test uses load drop under constant displacement as its primary crack growth detector. Significant load drop is required to be sure of crack growth. For long hold times near the threshold stress intensity cracking level two runs with 16 hours holds are often required. Acoustic emission added to the tests to provide enhanced detection to the onset of cracking. AE has the potential to detect crack growth much sooner and to allow the overall test time to be shortened. More detailed AE analysis can provide insight into individual crack growth events and micromechanics when multiple crack morphologies are involved and when significantly different threshold stress intensity levels are present. In this study the AE was used as a supplemental crack growth indication. Placing the transducer directly on the CTS specimen afforded excellent sensitivity. Normal signal noise from the Servohydraulic test system's actuator, was minimized by using hydraulic grips to hold the CTS fixture. Conventional threaded attachment of the fixture directly to the actuator results in major hydraulic related AE that makes sample cracking related AE very difficult. A 650kHz piezoelectric transducer was used to also reduced background test system noise. AE data coupled to the RSL tests are shown in figures 18-23 for 300M, C465, and S53.

For each displacement step there was AE activity related to the CTS sample pin rubbing during the increased displacement. Additionally for the initial displacement step the 3.5% NaCl solution was added after reaching the first step and this always resulted in AE activity. The AE generally was able to detect crack activity well before significant load drops. Alloy S53 exhibited significantly more AE than the other alloys even when load drop was not observed during a displacement step. However for the displacement steps prior to the step in which threshold cracking was determined based on significant continuous load drop, the AE activity which began in a very pronounced level dropped off sharply before the end of the hold time for these steps. Examination of the fracture surfaces revealed that while 300M and C465 were completely intergranular, the S53 crack path morphology was mixed intergranular with significant quasicleavage tearing. The quasicleavage explains the higher level AE activity. The decline in AE with time for displacement steps preceding the load drop defined cracking, suggests a more complex, time influenced stress relaxation near the threshold level, in which cracking initiates and then stops or slows as stress relaxation occurs until a critical level of stress intensity is reached at the next displacement level.

The stress corrosion cracking threshold stress intensity (K_{Isc}) values are listed in Table 5. These values were obtained using compact tension (CT) specimens and the rising step load procedure. Alloy 300M tempered at 400°F or at 575°F resulted in the lowest values. Tempering at 575°F resulted in a slight improvement from 15.5 to 18 $Ksi-in^{1/2}$ K_{Isc} value. Alloy S53 demonstrated the highest threshold level, 38 $Ksi-in^{1/2}$ while the K_{Isc} values for alloy C465 aged at either 950°F or 1000°F were in between 300M and S53 at 21 $Ksi-in^{1/2}$ and 34 $Ksi-in^{1/2}$ respectively.

Microstructure

Microstructural results using optical, scanning, and transmission electron microscopy were included in part A of this report and are not repeated in part B. All microstructures were consistent with microstructures for each alloy in the quench and tempered or aged conditions. Classical Fe₃C carbides were evident in 300M tempered at both 400°F and 575°F and are resolvable using field emission SEM, see part A figures 100-101. S53 tempered at high temperatures resulted in complex alloy carbides as expected and were visible in high resolution SEM imaging, see part A, figure 117. Precipitates in C465 were not resolvable even under high resolution SEM imaging and required TEM imaging and are included in part A.

c. Fractography

Fracture Toughness

The transition from fatigue precrack to crack initiation at the load corresponding to P_q during the plane strain fracture toughness tests for each alloy are shown in figures 24-25. Typical fracture surfaces during the crack extension are shown in figure 26. Alloy 300M's fracture mode was entirely transgranular microvoid coalescence for both temper conditions. C465 exhibited mixed quasicleavage and microvoid coalescence for both aging temperatures. Alloy S53 exhibited the most quasicleavage fracture mode. Both C465 and S53 fracture surfaces exhibited coarse intergranular features delineated by tear ridges consistent with prior austenite grain boundaries.

Impact Toughness

Charpy-V-notch fracture surfaces, figure 27, for samples tested at room temperature were similar to plane strain fracture surfaces in that alloy 300M tempered at 400°F exhibited microvoid coalescence. Tempering at 575°F resulted in shallower void coalescence approaching small quasicleavage features. No precipitates were visible after tempering at 575°F, while the microvoids in 300M tempered at 400°F nearly all contained precipitates. Alloy C465 and S53 fracture modes were similar to the plane strain fracture modes, showing increasing mixed quasicleavage and microvoid coalescence for C465 and virtually all quasicleavage for S53. Major tear ridges consistent with prior austenite grain boundaries were evident for both C465 and S53 alloys.

Fatigue Crack Growth

Fractographs, in the order of decreasing stress intensity are presented in figures 28 to 32, for each alloy. Alloy 300M exhibited completely transgranular fracture for all stress intensity ranges from 40 ksi-in^{1/2} to 8 ksi-in^{1/2}. Alloy C465 exhibited rougher fracture surfaces at higher stress intensity range with coarse features consistent with prior austenite grain size. As the stress intensity range decreased and crack growth rates decreasing, the fracture mode became more nearly completely transgranular without major tear ridges. For low stress intensity ranges transgranular fracture features were consistent with martensite microstructural features for both C465 and S53. For both C465 and S53 high stress intensity ranges resulted in crack branching, likely along prior austenite grain boundaries, figure 31a.

Stress Corrosion Cracking Specimens:

Unlike K_{1c} specimens, RSL test specimens failed intergranularly for all the alloys. The fracture surface of alloy 300M could not be observed in SEM due to extensive corrosion on the fracture surface. Figure 20 shows the SEM fractographs for specimens C465 aged at 950°F, 1000F and S53 aged at 934°F, which were fatigue precracked and then SCC tested. The cracks in the fatigue region followed transgranular mode and showed striations, while the SCC tested region was essentially intergranular for C465 aged at both 950°F and at 1000°F. Alloy S53 exhibited a significantly different SCC fracture morphology in that it was about 50%

transgranular quasicleavage failure with coarse grain boundary features, suggesting a mixed cracking mode consisting of intergranular stress corrosion cracking intermixed with brittle quasicleavage crack growth.

B4. DISCUSSION

A comprehensive set of mechanical properties, tensile, static and dynamic toughness, stress corrosion cracking and fatigue crack growth, have been developed for ultrahigh strength corrosion resistant steel alloys. These data have been referenced to the widely used conventional ultrahigh strength steel alloy, 300M. There was no one alloy that was superior in all test types. S53 had virtually the same fracture toughness as 300M, double the RSL threshold stress corrosion cracking level, but very low Charpy impact toughness. Custom 465 aged at 1000°F had the highest impact and fracture toughness, a high level of threshold stress intensity for stress corrosion cracking, and somewhat higher fatigue crack growth threshold stress intensity level than 300M, but these were achieved at a reduced yield and tensile strength levels, with the drop in ultimate tensile strength of over 20% compared to 300M. Characteristic of the Custom 465 alloy, the ultimate to yield strength ratio is much higher for 300M and S53 alloys, 1.2, than for C465, 1.05. Alloy 300M tempered at both 400°F and at 575°F exhibited higher impact toughness than S53 and C465 aged at 950°F. Only alloy C465 aged at 1000°F demonstrated higher impact toughness at the expense of a 20% drop in yield strength compared to 300M. As the fracture toughness increased the region II fatigue crack growth region extended to higher stress intensity ranges as expected. The high fracture toughness of C465 aged at 1000°F had a significantly higher region II stress intensity range than did the other alloys and also C465 aged 50°F lower temperature.

The fracture surfaces of the RSL stress corrosion cracking test specimens were intergranular for alloy alloys except for Ferrium S53, which was a mixed intergranular and transgranular quasicleavage. Acoustic emission results suggest that the intergranular cracking in C465 and 300M proceeded discontinuously grain by grain resulting in burst emission. This is consistent with a hydrogen embrittlement mechanism. Alloy S53 which exhibited about 50% intergranular and transgranular quasicleavage failure also exhibited significantly more acoustic emission suggesting that the occurrence of hydrogen induced grain boundary cracking was enhanced by quasicleavage tearing events that released significantly more acoustic emission than did 100% intergranular crack advancements. The low fracture toughness, comparable to 300M, of S53 resulted in competitive and iterative crack growth mechanisms with the quasicleavage generating significantly more AE than does intergranular cracking. Further analysis of the AE event characteristics including rise time, event duration, peak amplitudes etc coupled with a constant K type fracture sample would allow more detailed investigation of the crack advance mechanisms.

B5. CONCLUSIONS

Alloys Custom 465 and Ferrium S53 are designed as ultrahigh strength corrosion resistant alloys suitable for replacing conventional ultrahigh strength steel alloys such as 4340 and silicon modified 4340 (300M). These conventional alloys require protective coatings to guard against hydrogen induced stress corrosion cracking. The results obtained in this project showed an increase in threshold stress intensities for stress corrosion cracking, although still low compared to their fracture toughness. Near threshold stress intensities for fatigue crack growth

also showed some improvement but again were still low relative to their respective fracture toughness levels. Corrosion and corrosion fatigue properties were not determined in this study. The largest variation in properties was centered in their tensile properties, where the conventional steels have a much larger ultimate to yield strength ratio.

The relatively low Charpy-V-notch impact values for C465 and S53 compared to 300M was surprising based on their comparative plane strain fracture toughness values. Limited CVN tests were conducted to obtain benchmark values but were not a major focus of the project and may be related to the relative coarse prior austenite grain size in both alloys as compared to 300M. In all cases the notches were ground after final vacuum heat treatment.

If a single criterion, such as K_{Isc} or the upper limit to stage two fatigue crack growth rates, was key for an application then a decision on which alloy to consider would be straightforward. The selection of an alloy for a specific application requires a priority ranking of key properties.

B6. ACKNOWLEDGEMENTS

This material is based upon work supported by, or in part by, the U. S. Army Research Laboratory and the U. S. Army Research Office under grant number W911NF-08-1-0046. PSU thanks Carpenter Technology for providing the C465 and S53 alloys at a significant discount and for forging to laboratory sized coupons suitable for preparing the test samples. PSU also thanks Met-Tech Inc for providing heat treatment of the test samples. At PSU a team of materials science and engineering faculty, staff and graduate students that included J.McCarthy, R. Nordstrom, T. Quale, R. Turpin, J. Kadali, and R. Talla contributed to the success of this project.

B7. LIST OF TABLES AND FIGURES

Table List

1. Alloy Chemical compositions, wt%
2. Heat Treatment profile
3. Plane Strain Fracture toughness for each alloy
4. Tensile properties for each alloy
5. Charpy-V- notch impact toughness for each alloy
6. Rising Step Load determined K_{Isc} threshold values for each alloy

Figure List

1. Test Specimen configurations; all unites in inches
2. Instron Servohydraulic test system configured for Rising step load test
3. Rising step load configuration with acoustic emission sensor attached to specimen and Vallen AE- AMSY5 system for recording load, displacement, time, and AE signals
4. Schematic diagram of Vallen AMSY 5 AE system configured for cracking detection
5. Comparison chart of mechanical properties for each alloy and heat treatment
6. Generic fatigue crack growth curve illustrating three crack growth regions
7. Fatigue Crack Growth Rate vs Delta K for 300M quenched and tempered at 400°F
8. Fatigue Crack Growth Rate vs Delta K for 300M quenched and tempered at 575°F
9. Fatigue Crack Growth Rate vs Delta K for C465 aged at 950°F
10. Fatigue Crack Growth Rate vs Delta K for C465 aged at 1000°F
11. Fatigue Crack Growth Rate vs Delta K for S53 quenched and tempered at 934°F+900°F
12. Comparison of Fatigue Crack Growth Rates for 300M, C465, and S53
13. a,b, Rising Step Load, 1&2 hr holding time, results for 300M tempered at 575°F
c,d Rising Step Load, 4&8 hr holding time, results for 300M tempered at 575°F
14. a,b Rising Step Load, 1&2 hr holding time, results for 300M 400°F temper
c&d Rising Step Load,4&8 hr holding time, results for 300M 400°F temper
15. a&b, Rising Step Load, 1&2 hr holding time, results for C465 aged at 950°F
c&d, Rising Step Load, 1&2 hr holding time, results for C465 aged at 950°F
e, Rising Step Load, 1&2 hr holding time, results for C465 at 950°F
16. a&b, Rising Step Load, 1&2 hr holding time, results for C465 aged at 1000°F
c&d, Rising Step Load, 4&8 hr holding time, results for C465 aged at 1000°F
17. a&b, Rising Step Load, 1&2 hr holding time, results for S53aged at 934°F+900°F
c&d, Rising Step Load, 4&8 hr holding time, results for S53aged at 934°F+900°F
18. a&b, Rising step load K_{Isc} test coupled with acoustic emission for 300M tempered at 400°F
19. Rising step load K_{Isc} test coupled with acoustic emission for 300M tempered at 575°F
20. a&b, Rising step load K_{Isc} test coupled with acoustic emission for C465aged at 950°F
21. Rising step load K_{Isc} test coupled with acoustic emission for C465 aged at 1000°F, 1hr hold
22. Rising step load K_{Isc} test coupled with acoustic emission for C465 aged at 1000°F, 2hr hold
23. RSL, K_{Isc} test coupled with AE for S53 tempered at 934°F & 900°F, 2hr hold
24. SEM Fractographs of K1c specimens, showing fatigue precrack and crack initiation zones for
(a) 300M tempered at 400oF, (b) 300M tempered at 575oF, (c) C465 aged at 950oF, (d)
C465 aged at 1000oF and (e) S53 aged at 934oFand 900oF; variable magnifications

25. SEM fractographs of K_{Ic} specimens, showing crack initiation zones for (a) 300M tempered at 400°F, (b) 300M tempered at 575°F, (c) C465 aged at 950°F, (d) C465 aged at 1000°F and (e) S53 aged at 934°F and 900°F; variable magnifications
26. SEM fractographs of K_{Ic} Specimens, comparing dimple size and distribution (a) 300M tempered at 400°F, (b) 300M tempered at 575°F, (c) C465 aged at 950°F, (d) C465 aged at 1000°F and (e) S53 aged at 934°F and 900°F; variable magnifications
27. SEM fractographs of Charpy impact toughness specimens, (a) 300M tempered at 400°F, (b) 300M tempered at 575°F, (c) C465 aged at 950°F, (d) C465 aged at 1000°F and (e) S53 aged at 934°F and at 900°F; variable magnifications
28. : SEM fractographs of da/dn tested 300M tempered at 400°F; (a) & (b) $\Delta K = 40 \text{ ksi-in}^{1/2}$ (c) & (d) $\Delta K = 28 \text{ ksi-in}^{1/2}$ (e) & (f) $\Delta K = 18 \text{ ksi-in}^{1/2}$ (g) & (h) $\Delta K = 10 \text{ ksi-in}^{1/2}$
29. SEM fractographs da/dn tested 300M tempered at 575°F; (a) & (b) $\Delta K = 42 \text{ ksi-in}^{1/2}$ (c) & (d) $\Delta K = 30 \text{ ksi-in}^{1/2}$ (e) & (f) $\Delta K = 20 \text{ ksi-in}^{1/2}$ (g) & (h) $\Delta K = 8 \text{ ksi-in}^{1/2}$
30. SEM fractographs of da/dn tested C465 Aged at 950°F; (a) & (b) $\Delta K = 52 \text{ ksi-in}^{1/2}$ (c) & (d) $\Delta K = 40 \text{ ksi-in}^{1/2}$ (e) & (f) $\Delta K = 28 \text{ ksi-in}^{1/2}$ (g) & (h) $\Delta K = 16 \text{ ksi-in}^{1/2}$
31. SEM fractographs of da/dn tested C465 Aged at 1000°F; (a) & (b) $\Delta K = 90 \text{ ksi-in}^{1/2}$ (c) & (d) $\Delta K = 66 \text{ ksi-in}^{1/2}$ (e) & (f) $\Delta K = 44 \text{ ksi-in}^{1/2}$ (g) & (h) $\Delta K = 20 \text{ ksi-in}^{1/2}$
32. SEM fractographs of da/dn tested S53 Aged at 934°F and 900°F; (a) & (b) $\Delta K = 38 \text{ ksi-in}^{1/2}$ (c) & (d) $\Delta K = 28 \text{ ksi-in}^{1/2}$ (e) & (f) $\Delta K = 18 \text{ ksi-in}^{1/2}$ (g) & (h) $\Delta K = 12 \text{ ksi-in}^{1/2}$
33. SEM fractographs of RSL K_{Isc} specimens showing intergranular failure in C465 aged at 950°F and at 1000°F, (a-d); and mixed intergranular and transgranular quasicleavage in S53 aged at 934°F and 900°F, (e) and (f).

B8. TABLES AND FIGURES

Table 1: Alloys Chemical Composition, wt%.

Alloy	Fe	Co	Cr	Mo	Ni	Ti	C	Mn	S	Si	W	V	P
300M	Bal	--	0.95	0.65	2.0	--	0.46	0.9	0.01	1.8	--	0.05	0.01
Custom 465	Bal	--	12.5	1.25	11.25	1.8	0.02	0.25	0.010	--	--	--	--
FerriumS-53	Bal	14	10	2.0	5.5	--	0.2	--	--	--	1.0	0.3	--

Table 2: Heat Treatment Profiles.

Alloy	Specimen ID	Heat treatment
300M	D	(a) Solution HT @ 1600°F for 1hr, oil quench then tempered @ 400°F for 2hrs and air cooled
	C	(b) Solution HT @ 1600°F for 1hr, oil quench then tempered @ 575°F for 2hrs and air cooled
Custom 465	G	(a) Solution Annealed to 1800° F for 1hr , refrigerated to -100°F for 8hrs, warming to RT then aged at 1000°F for 4hrs and air cooled
	H	(b) Solution Annealed to 1800°F for 1hr , refrigerated to -100°F for 8hrs , warming to RT then aged at 950°F for 4hrs and air cooled
Ferrium S-53	K	Solution HT @ 1985°F for 1hr , oil quench, refrigerated to -100°F for 1hr , warming to RT, tempered to 934°F for 3hrs, oil quench, refrigerated to -100°F for 1hr, warming to RT, reheating to 900°F for 12 hrs and air cool.

Table 3: Plane Strain Fracture Toughness for each alloy.

Alloy	Plane Strain Fracture toughness K_{Ic} , ksi-in ^{1/2} (MPa-m ^{1/2})													
	400°F temper							575°F temper						
300M	54.9 (60.3)	56.7 (62.3)	55.8 (61.3)	57.1* (62.7)	55.9* (61.4)	54.5* (59.8)	54.4 (59.7)	54.5 (59.8)	60.6 (66.5)	59.1 (64.9)	65* (71.4)	57.9* (63.6)	56* (61.5)	
C465	950°F age						1000°F age							
	80 (87.8)	74 (81.3)	80.9 (88.8)	75.3* (82.7)	72.1* (79.2)	78.6* (86.3)	117 (128.5)	119.4 (131.1)	122 (134)	133.6* (146.7)	113.8* (125)	116.5* (128)		
S-53	934°F +900°F temper													
	52.4 (57.5)	56.1 (61.6)	54 (59.3)	56.4* (62)	52.2* (57.3)	54.3* (59.6)								

*a/w ratio exceeds maximum allowable value, (0.45 < a/w < 0.55) for valid K_{Ic} test. K1 test done after completion of Da/Dn test

Table 4: Tensile Properties for each alloy.

Y.S: Yield Strength offset 0.2%, UTS: Ultimate Tensile Strength, El: Elongation (%), RA: Reduction in Area (%) (Above values

Alloy	YS ksi (Mpa)	UTS ksi (Mpa)	Elong (%)	RA (%)	Young's Modulus Ksi	Poisson's Ratio
300M 400°F	242 (1,668)	306 (2,137)	12	40	30,929	0.31
300M 575°F	250 (1,723)	299 (2,088)	12	45	32,565	0.31
C465 950°F	239 (1,669)	254 (1,774)	11	52	30,167	0.31
C465 1000°F	219 (1,529)	230 (1,606)	12	61	29,936	0.31
S53	232 (1,620)	284 (1,983)	14	55	31,150	0.31

are averages of 5 samples tested at same heat treatments.)

Table 5: Charpy-V-notch Impact Toughness, ft-lbs.

Test Temperature, °F	300M Tempered 400°F	300M Tempered 575°F	C465 Aged 950°F	C465 Aged 1000°F	S53 Aged 934°F+900°F
212			20	34.5	11.5
			20	33.5	10.5
Avg			20	34	11
72	17	15.5	11	24.5	5
	17	14.5	18	25	4.5
	17.5	13	13	27	4.5
	17.5	16	13.5	26	4
Avg	17.3	14.8	13.9	25.6	4.5
32	16.5	15	9.5	21.5	4
		15	9	20	3.5
Avg	16.5	15	9.3	20.8	3.8
-40	15.5	10.5	3	11	3
	13	9.5	3.5	9.5	2.5
Avg	14.3	10	3.3	10.3	2.8
-76			2.5	7	2.5
			3	7.5	2
Avg			2.8	7.3	2.3

Table 6: Fracture Toughness , Stress Corrosion Cracking and DaDn Threshold Stress Intensities

Alloy (temper or age temp.)	K_{Ic} (Ksi-in^{1/2})	K_{Isc} (ksi-in^{1/2})	ΔK (ksi-in^{1/2}) Threshold DaDn
300M (400°F)	56	15.5	6
300M (575°F)	58	18	6
S53 (935+900°F)	54	38	8
C465 (950°F)	78	21	12
C465 (1000°F)	119	34	9

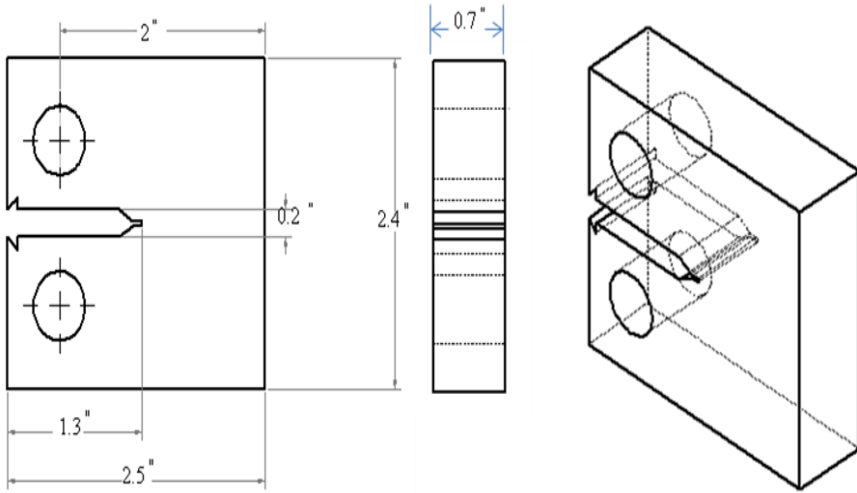

ASTM-E399

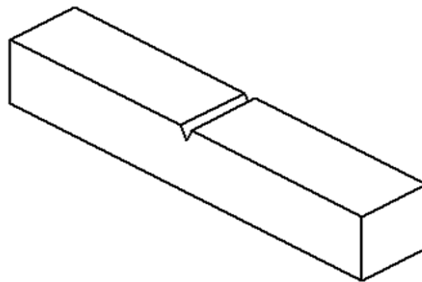
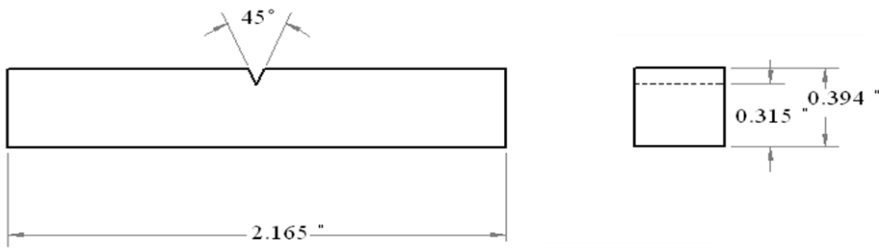

ASTM-E23

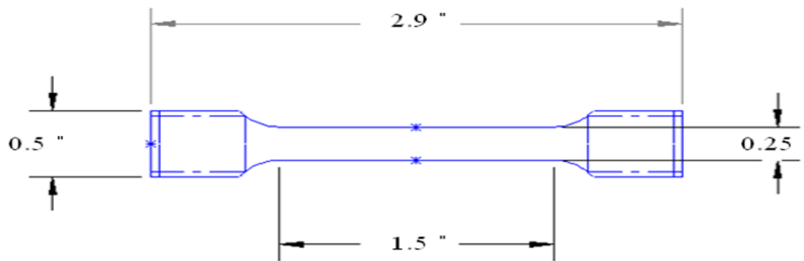

ASTM-E8

Figure 1 Test specimen configurations; all units in inches

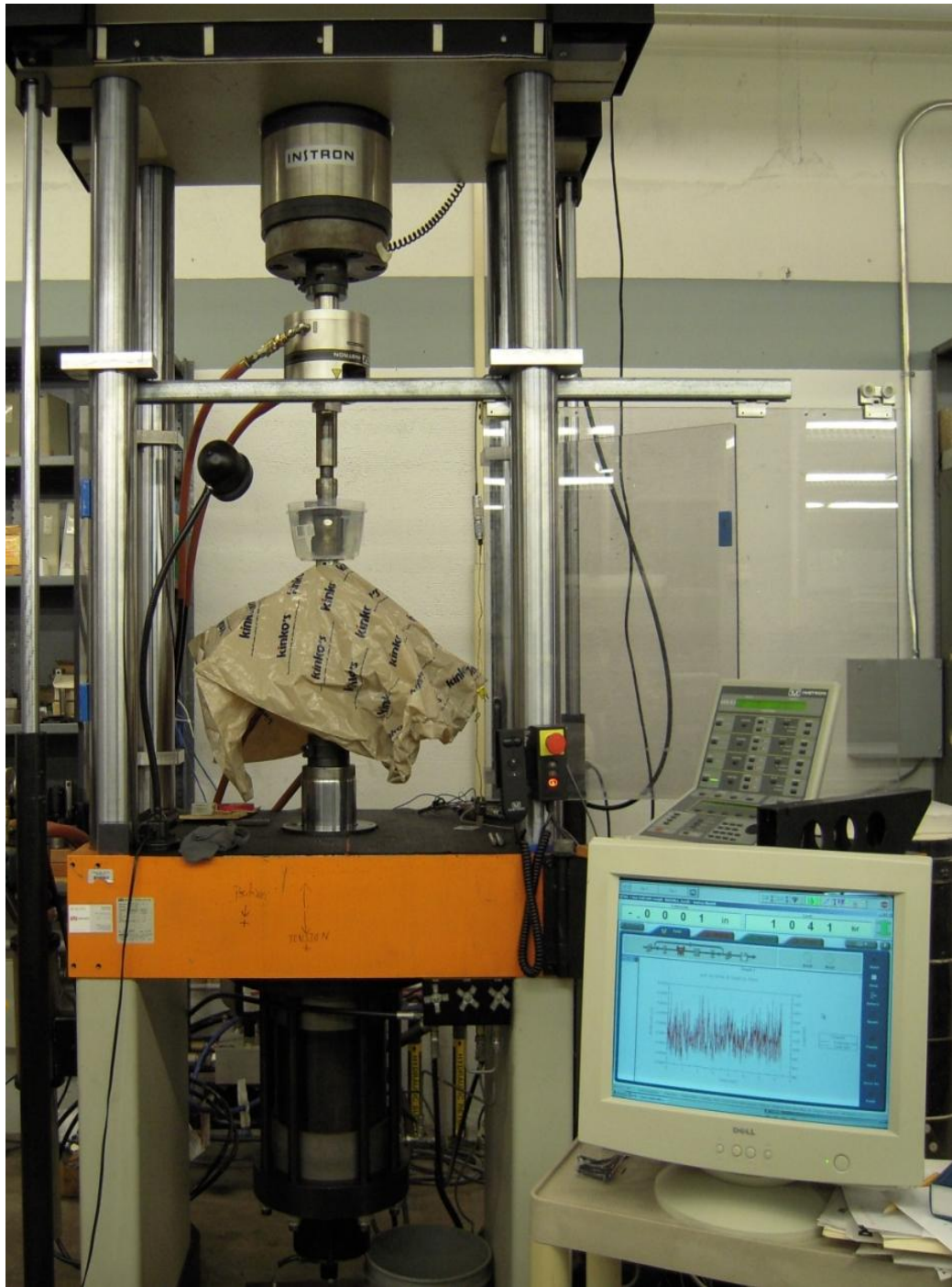

Figure 2, Instron servohydraulic test system configured for rising step load threshold stress intensity cracking determination in 3.5% NaCl.

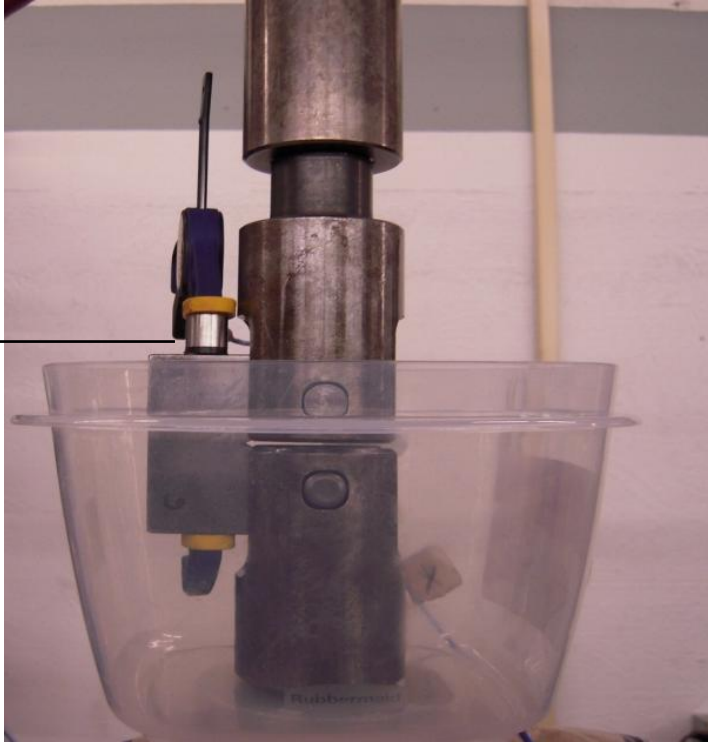

Figure 3, Rising Step load E399 test sample with acoustic emission sensor attached; Vallen multichannel AE AMSY5 system

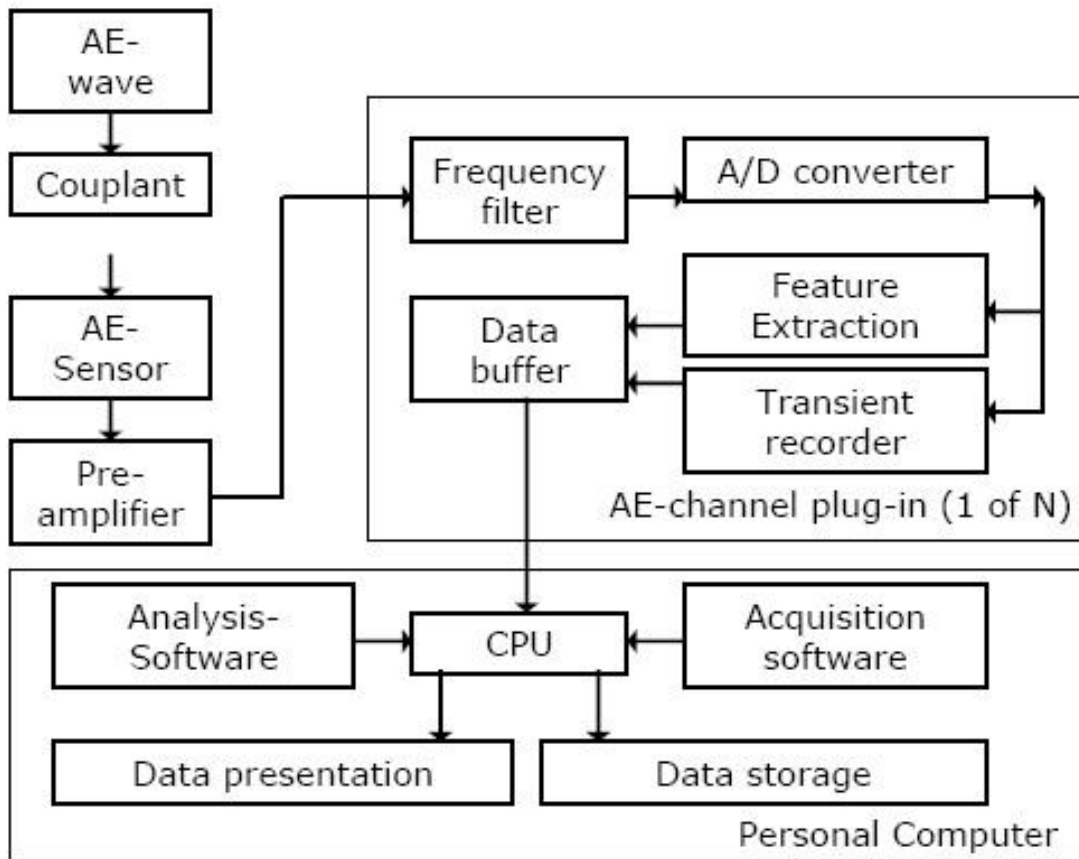

Figure 4, Vallen Acoustic Emission System

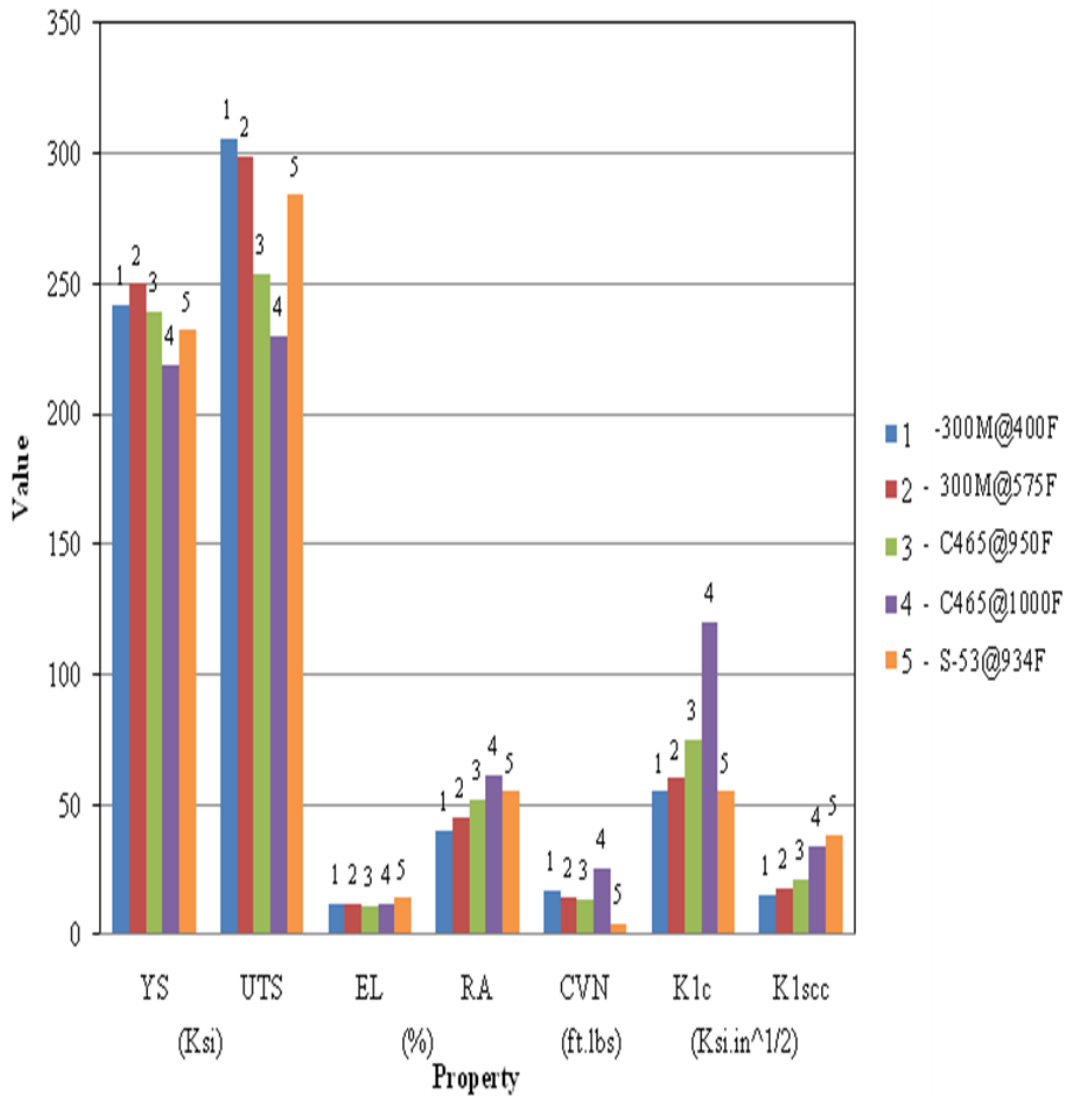

Figure 5: Comparison of room temperature mechanical properties for each alloy/heat treatment

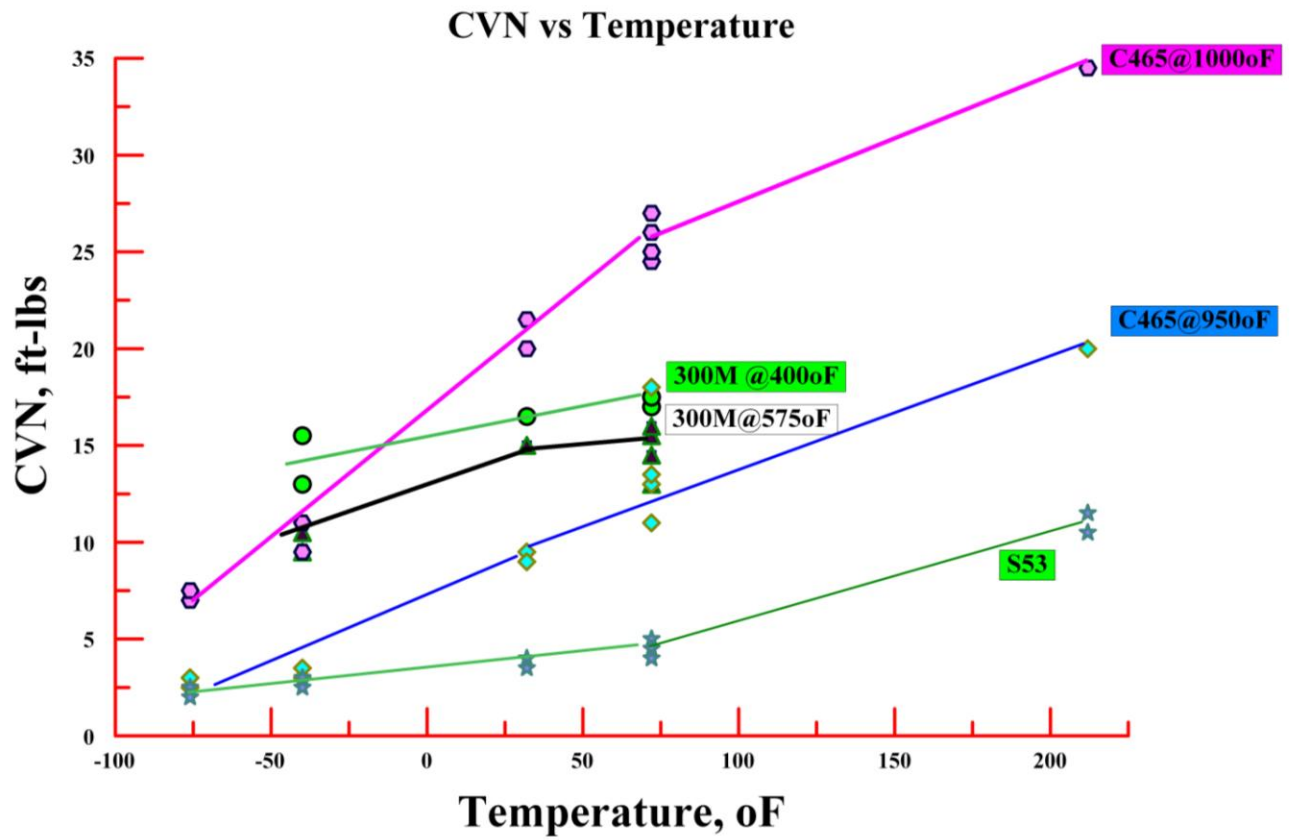

Figure 5a: CVN versus test temperature for each alloy, see (table 5 for data)

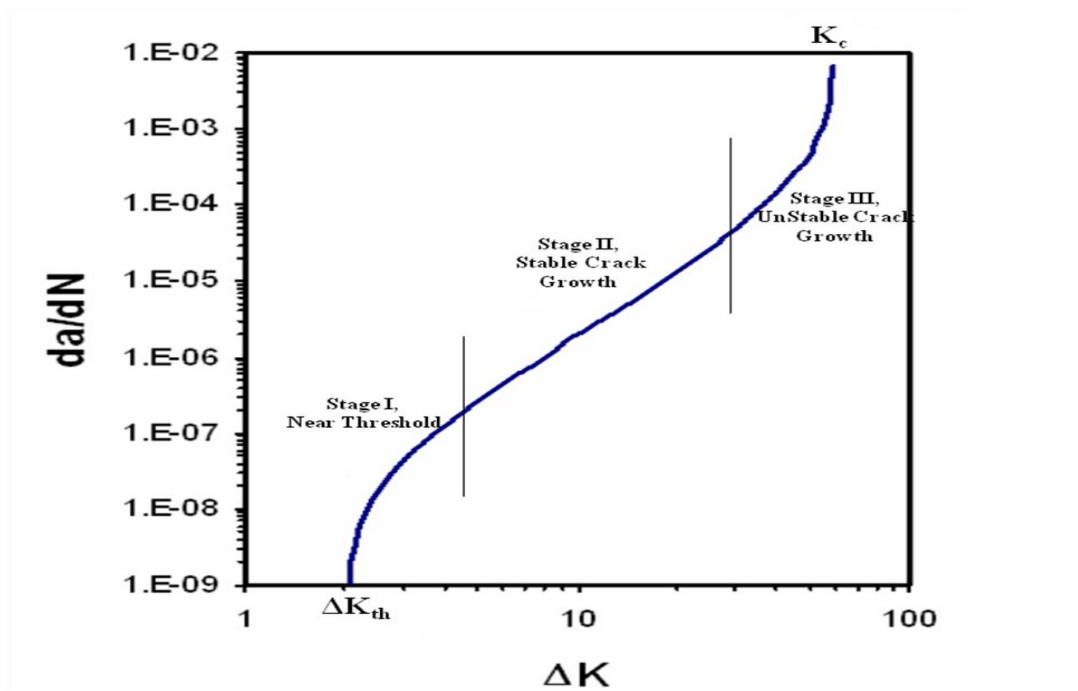

Figure 6: Fatigue Crack Growth Curve showing three regions

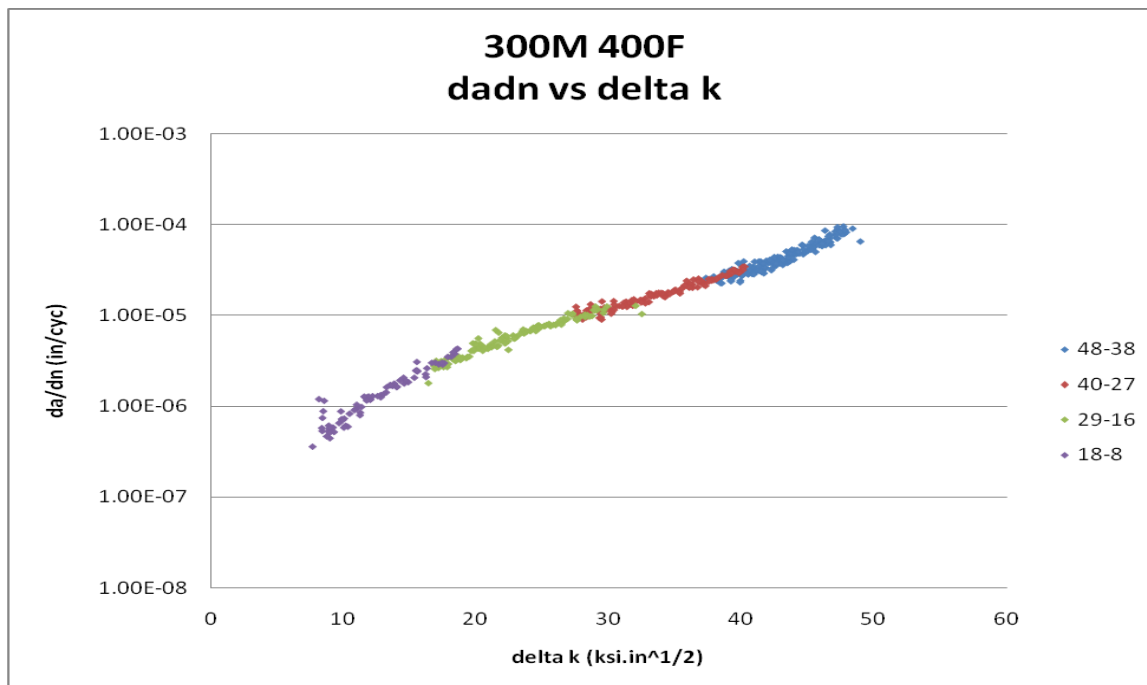

Figure 7: Fatigue Crack Growth Rate vs Delta K for 300M quenched and tempered at 400°F

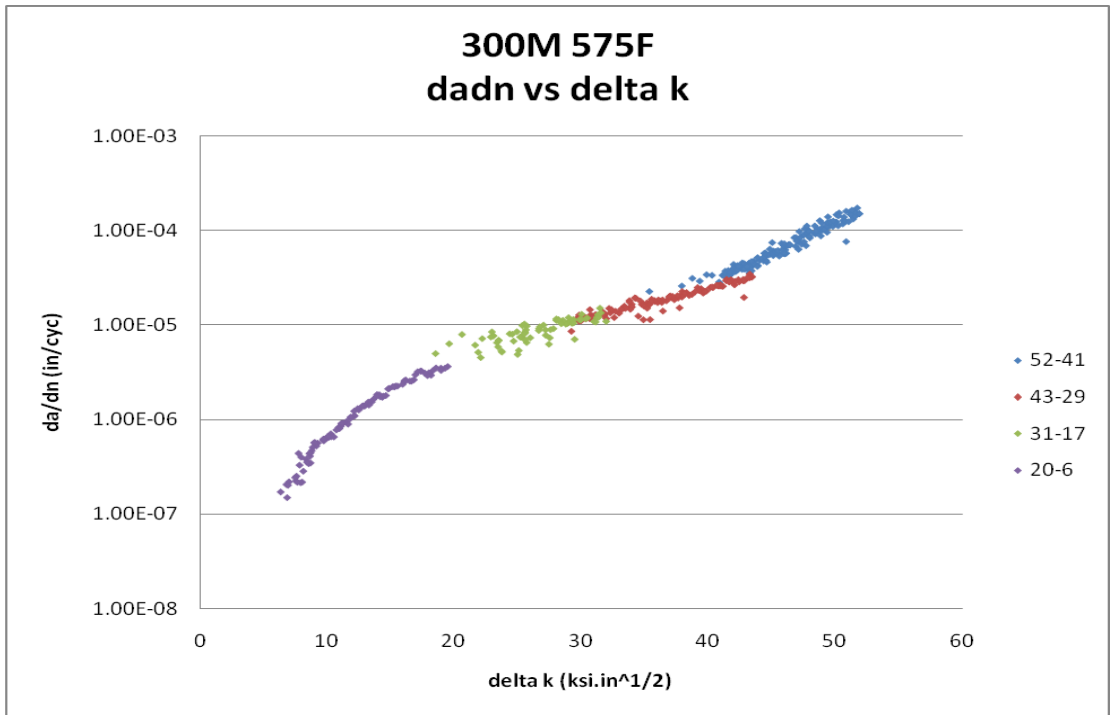

Figure 8: Fatigue Crack Growth Rate vs Delta K for 300M quenched and tempered at 575°F

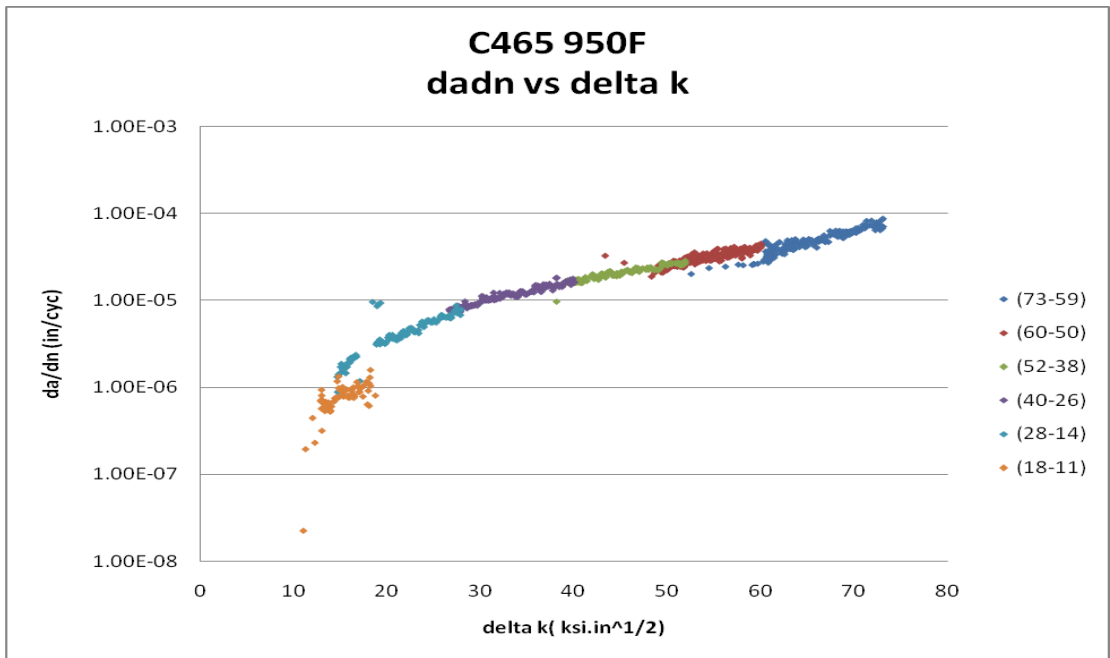

Figure 9: Fatigue Crack Growth Rate vs Delta K for C465 aged at 950°F

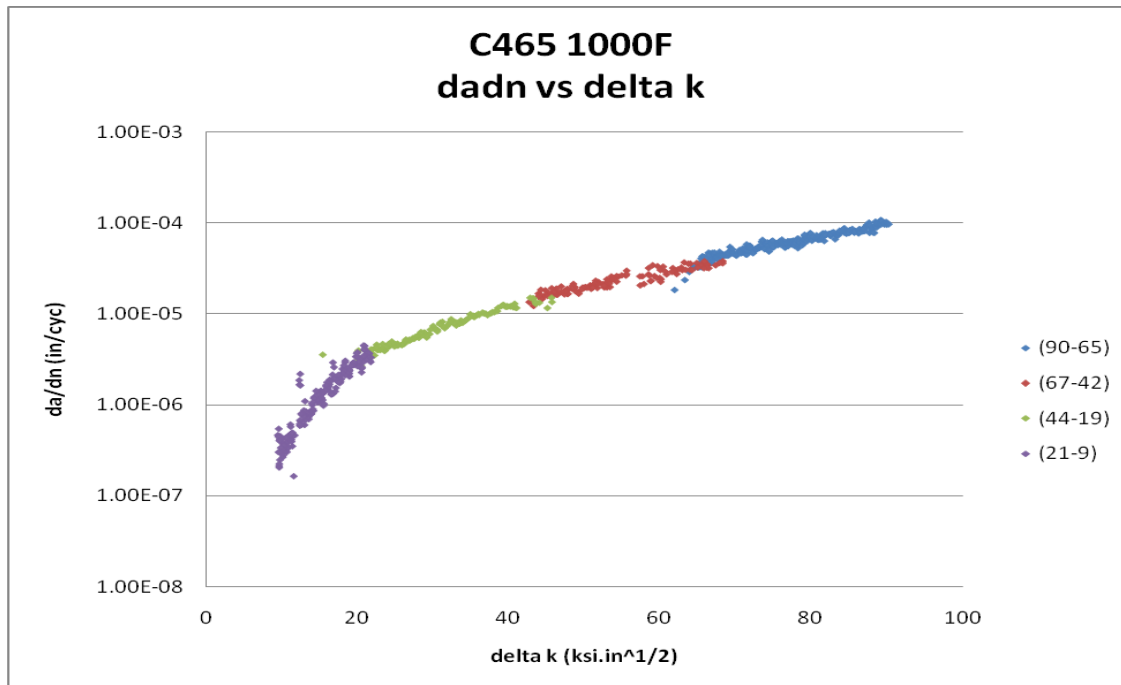

Figure 10: Fatigue Crack Growth Rate vs Delta K for C465 aged at 1000°F

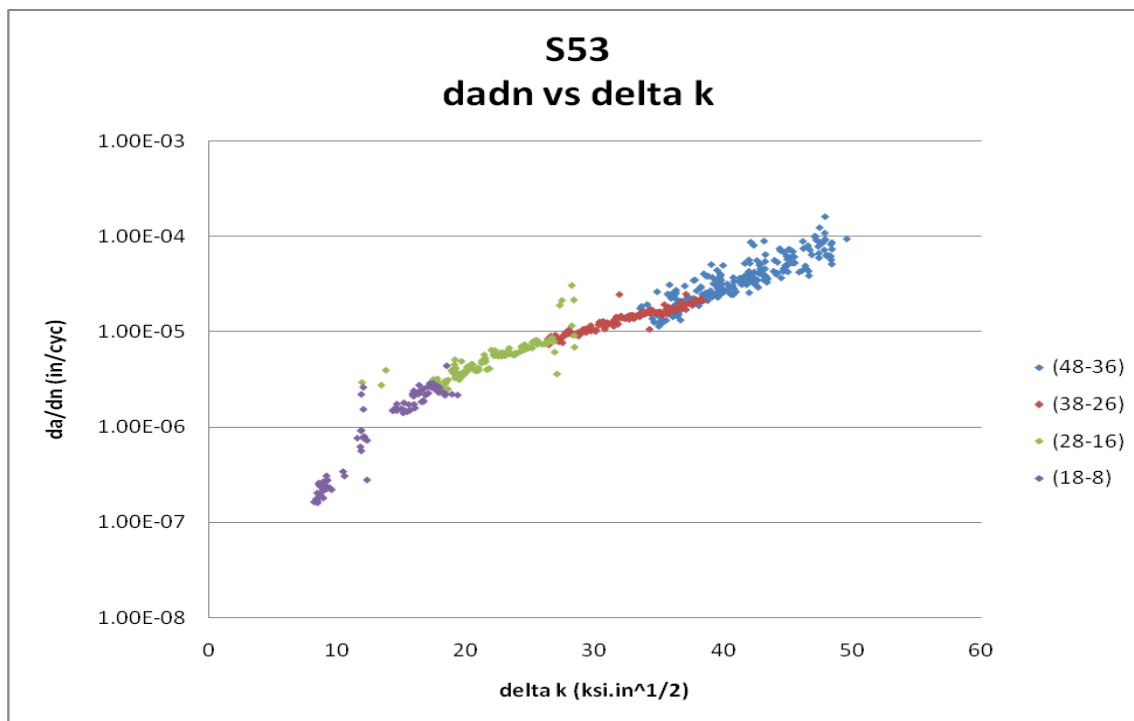

Figure 11: Fatigue Crack Growth Rate vs Delta K for S53 quenched and tempered at 934°F+900°F

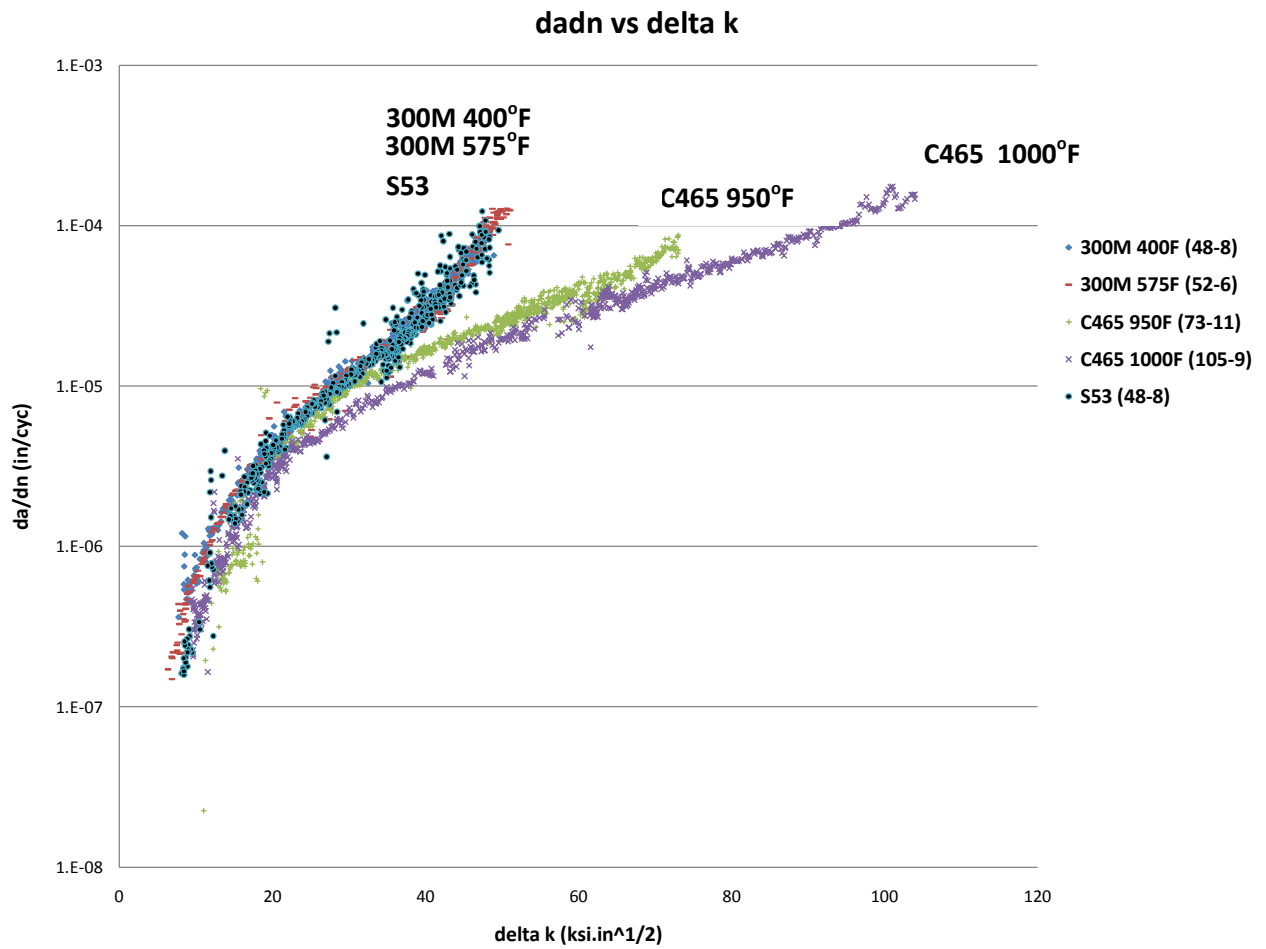

Figure 12: Comparison of Fatigue Crack Growth Rates for 300M, C465, and S53

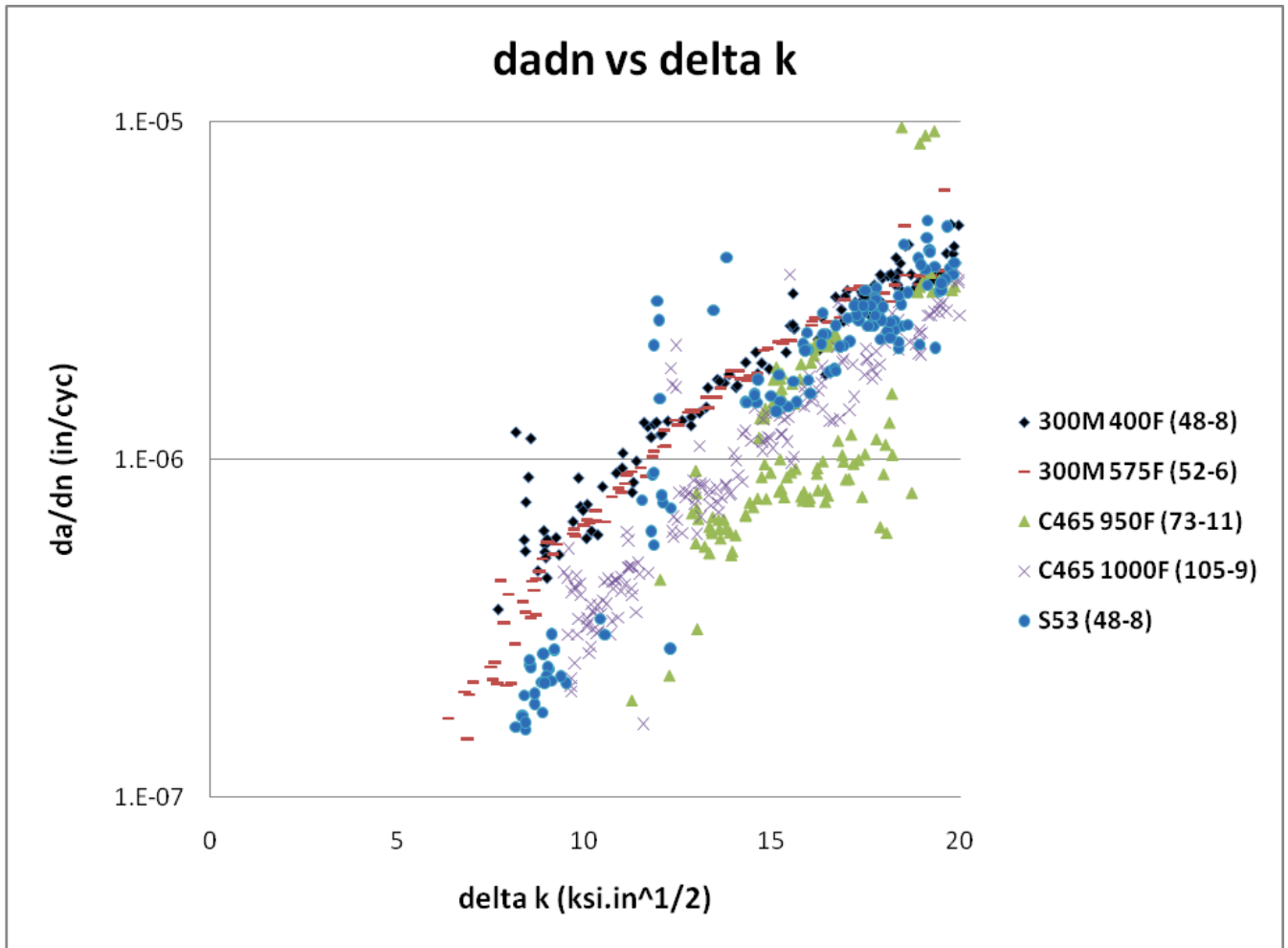

Figure 12a Comparison of Fatigue Crack Growth Rates for 300M, C465, and S53; expanded portion near threshold region of figure 12

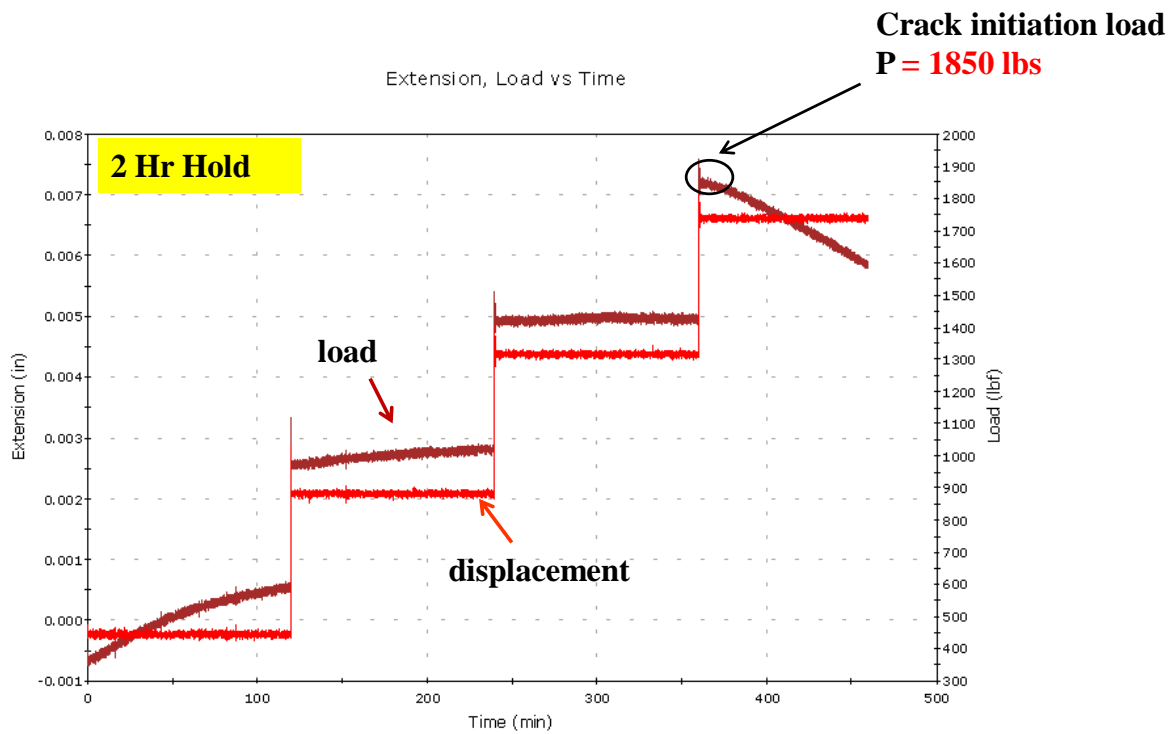
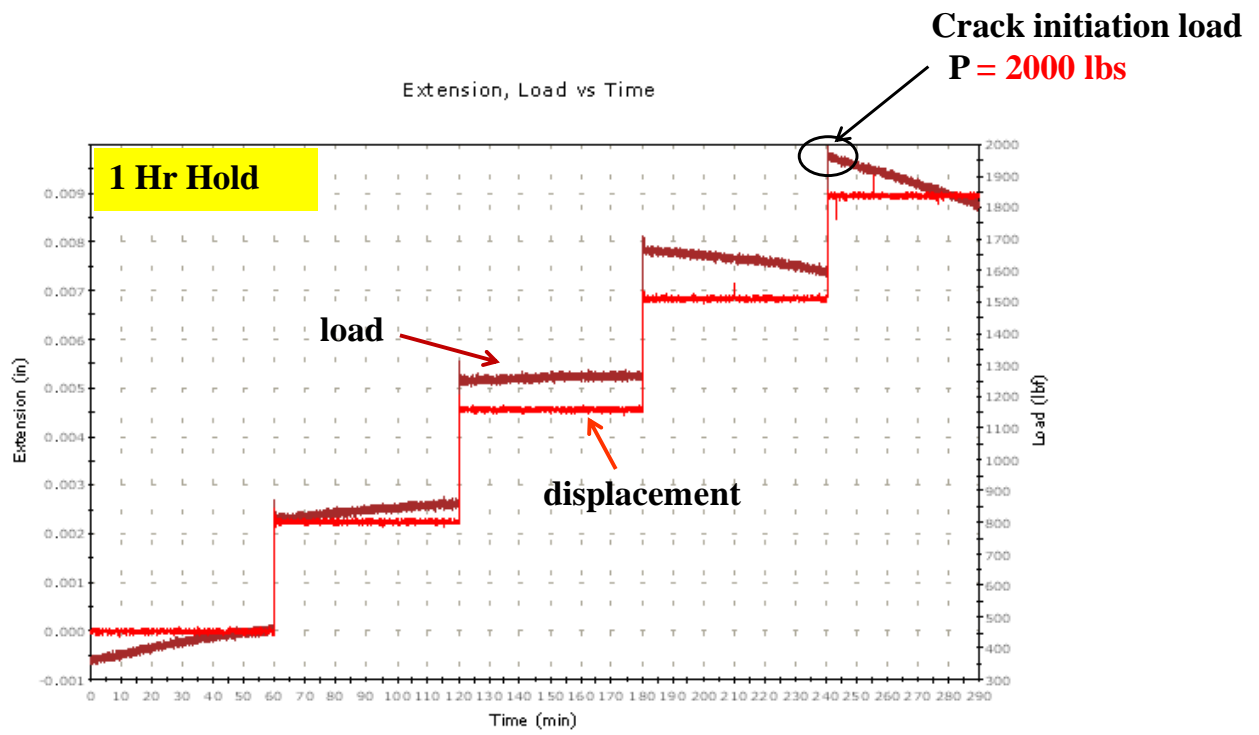

Figure 13a,b Rising Step Load, 1&2 hr holding time, results for 300M tempered at 575°F

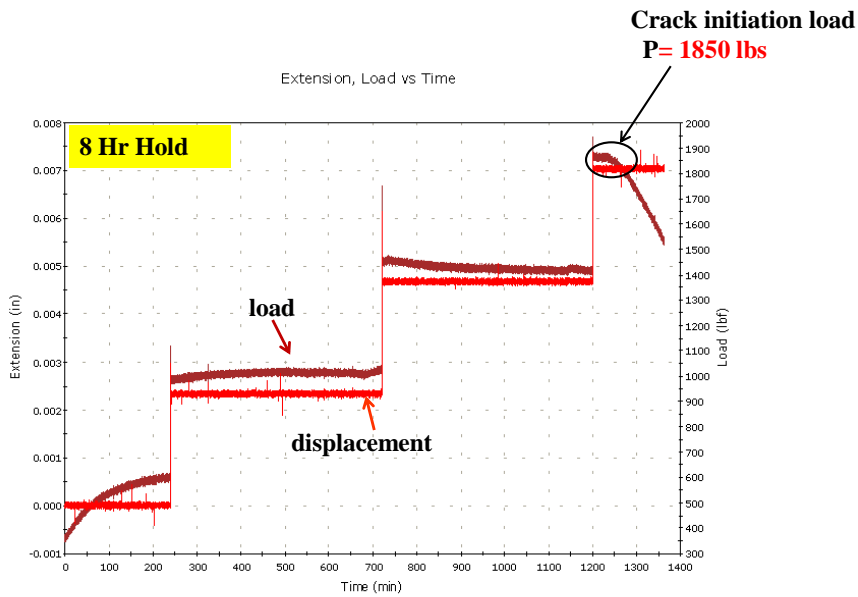
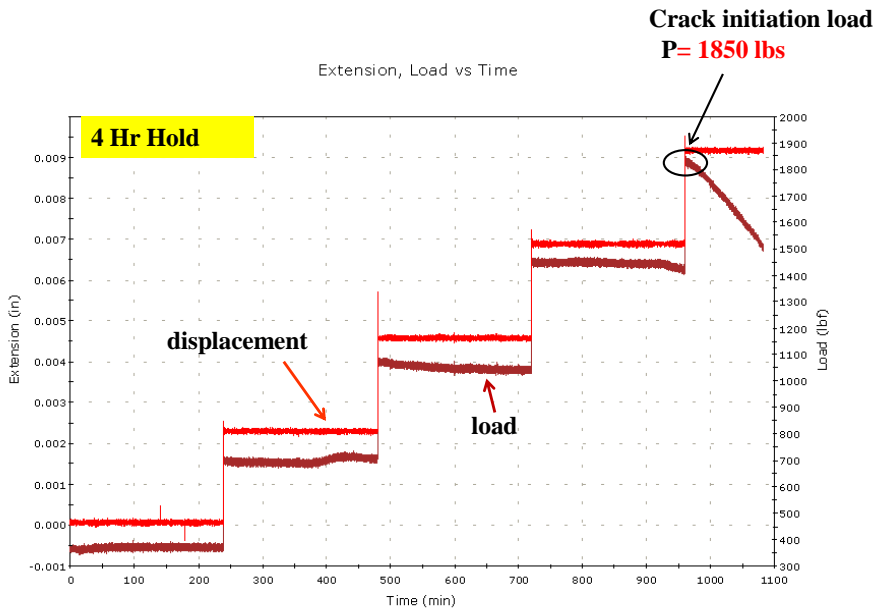

Figure 13c,d Rising Step Load, 4&8 hr holding time, results for 300M tempered at 575°F

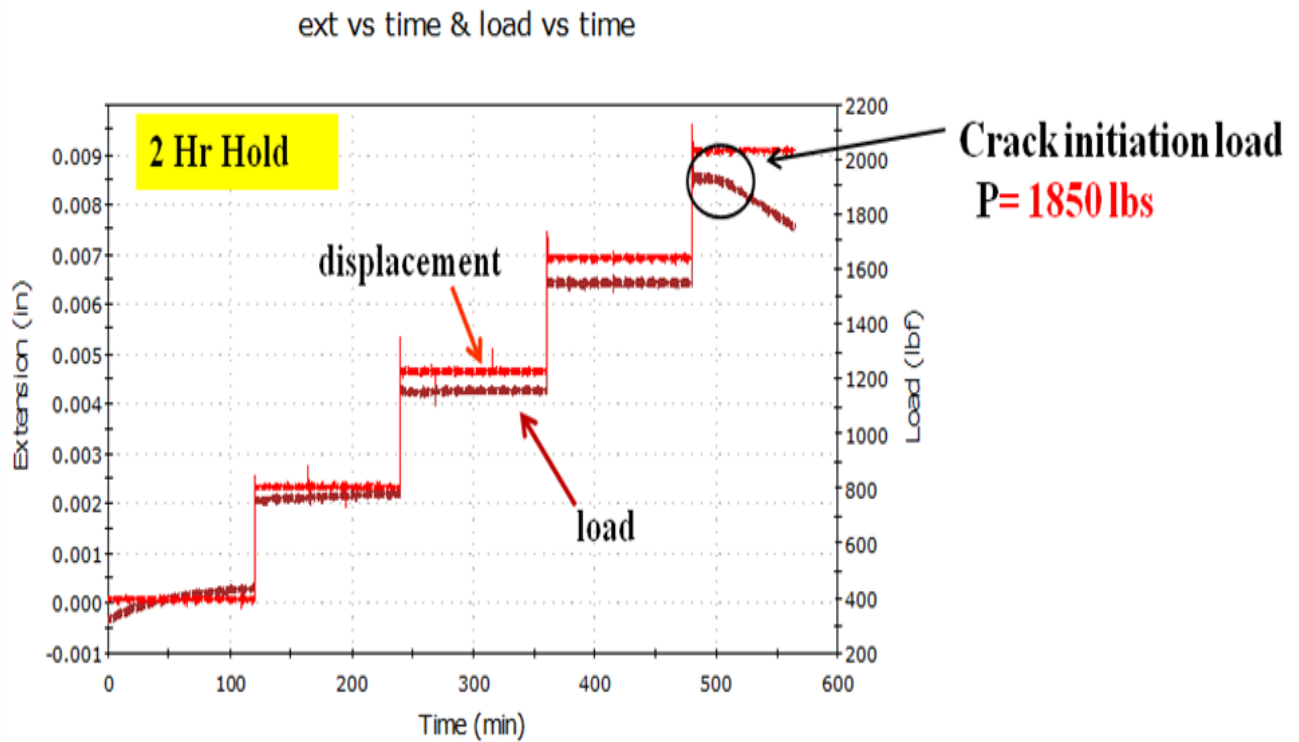
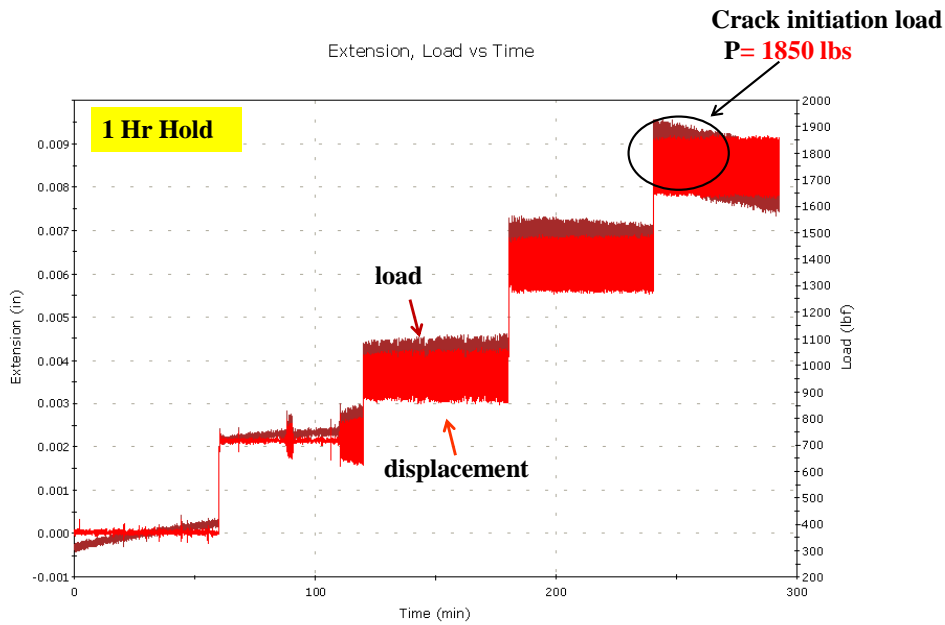

Figure 14a,b Rising Step Load, 1&2 hr holding time, results for 300M 400°F temper

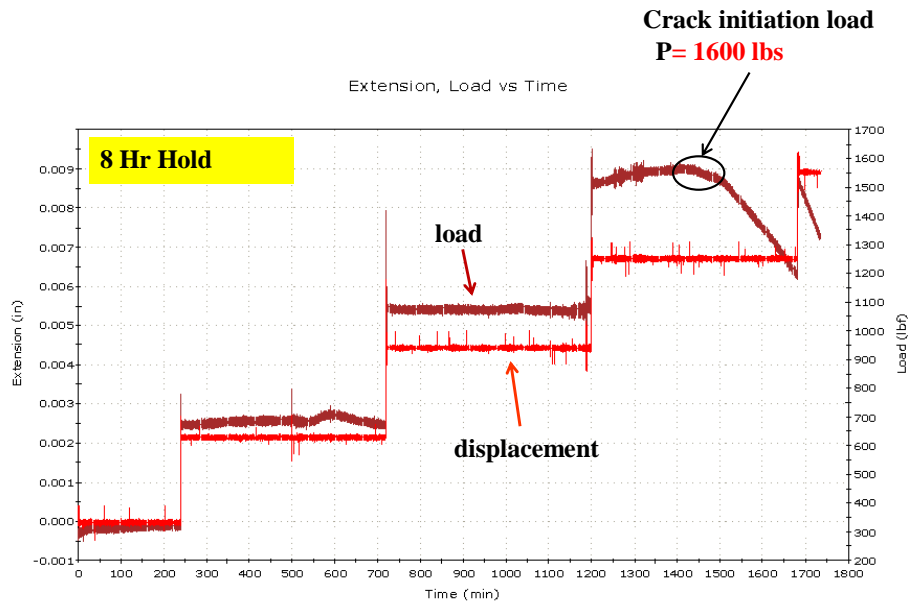
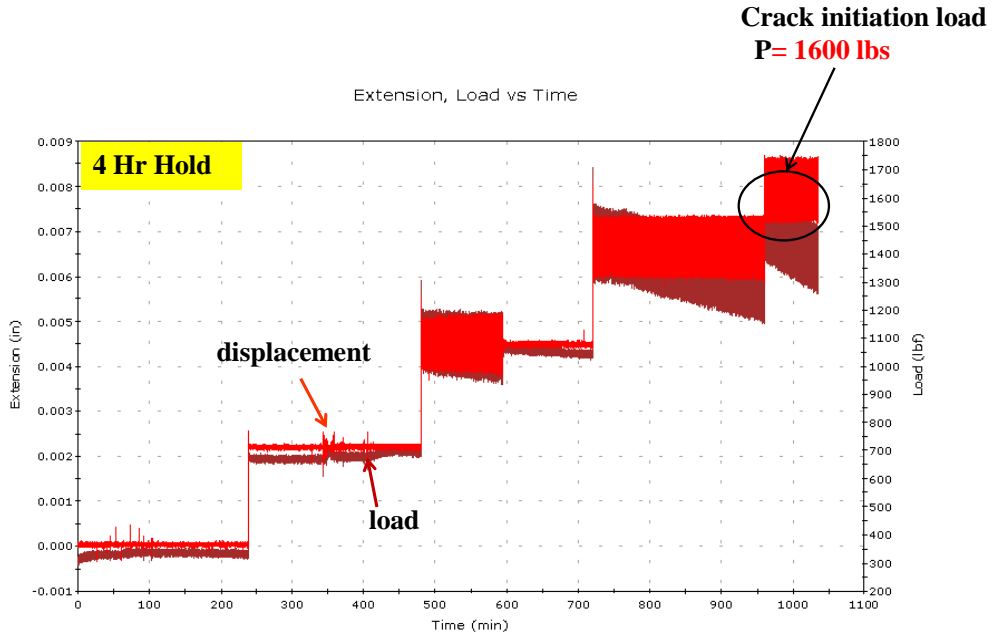

Figure 14c&d Rising Step Load, 4&8 hr holding time, results for 300M 400°F temper

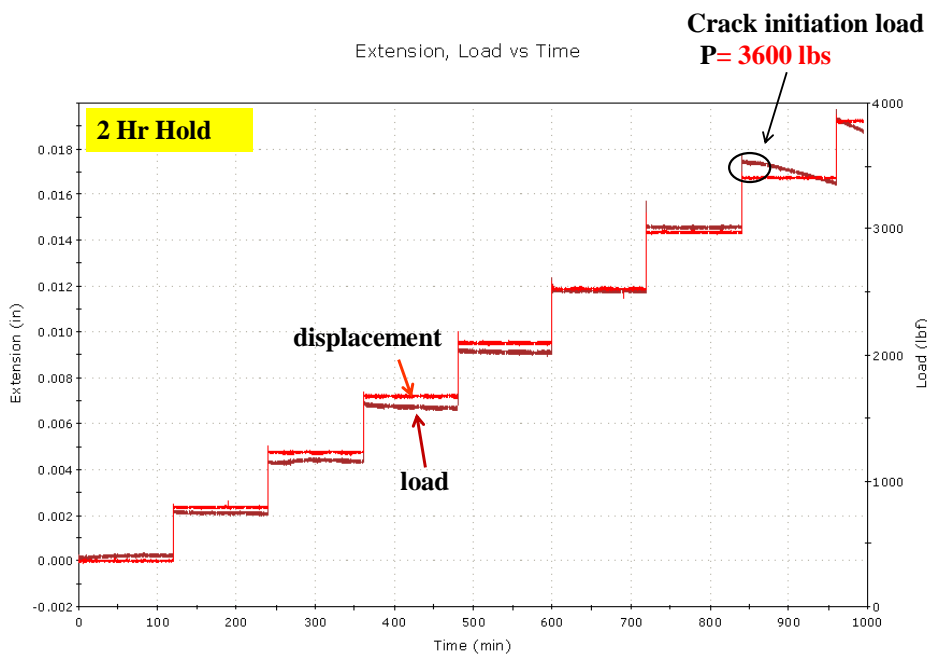
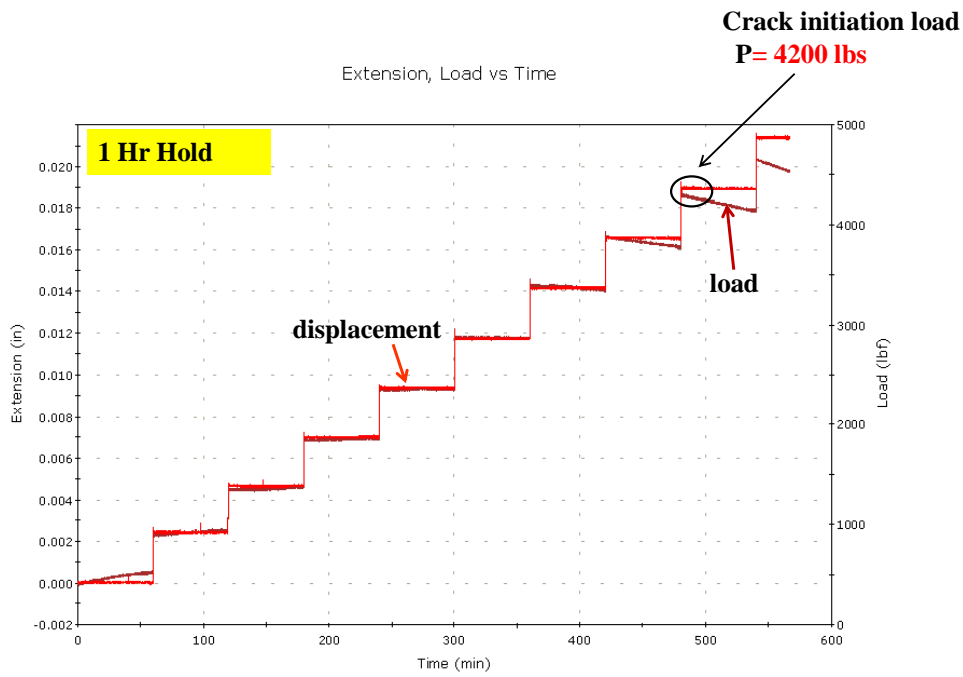

Figure 15a&b, Rising Step Load, 1&2 hr holding time, results for C465 aged at 950°F

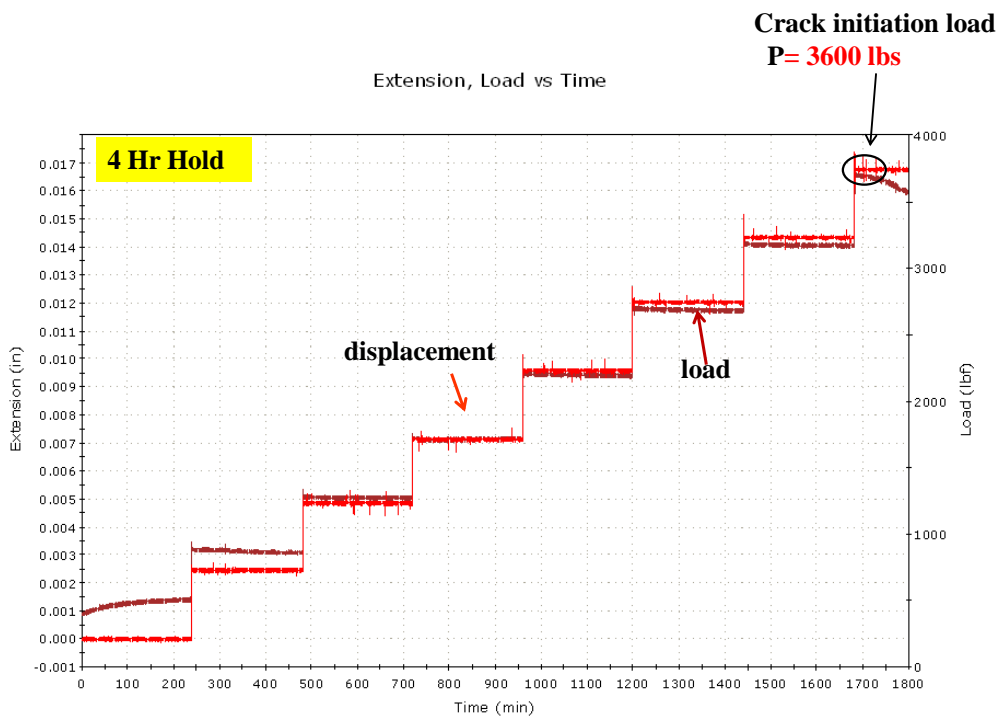
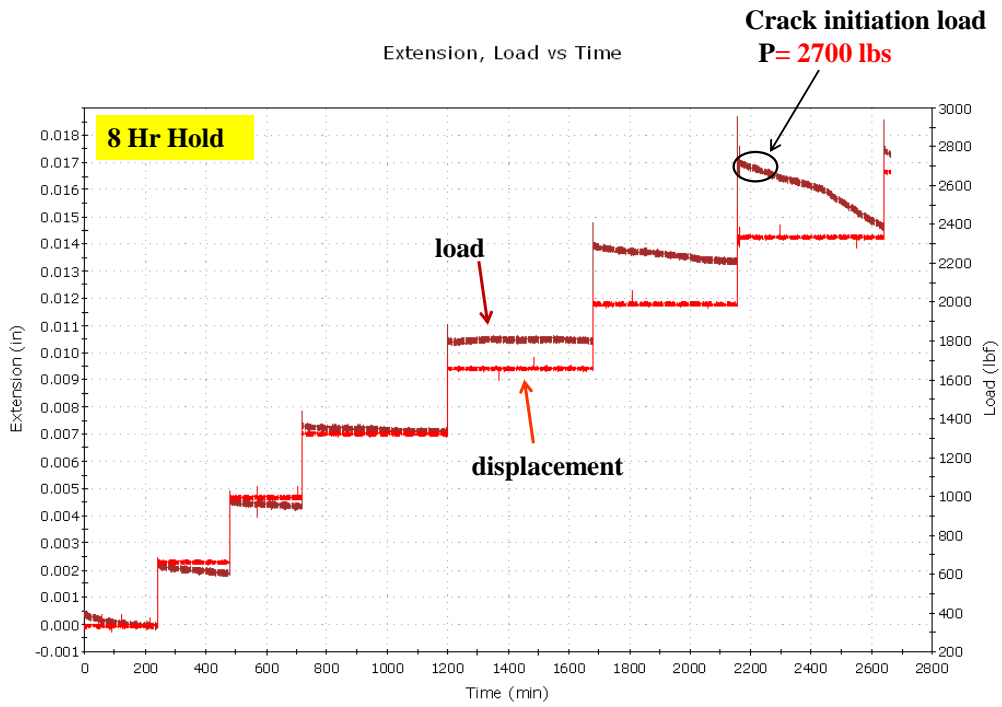

Figure 15c&d, Rising Step Load, 1&2 hr holding time, results for C465 aged at 950°F

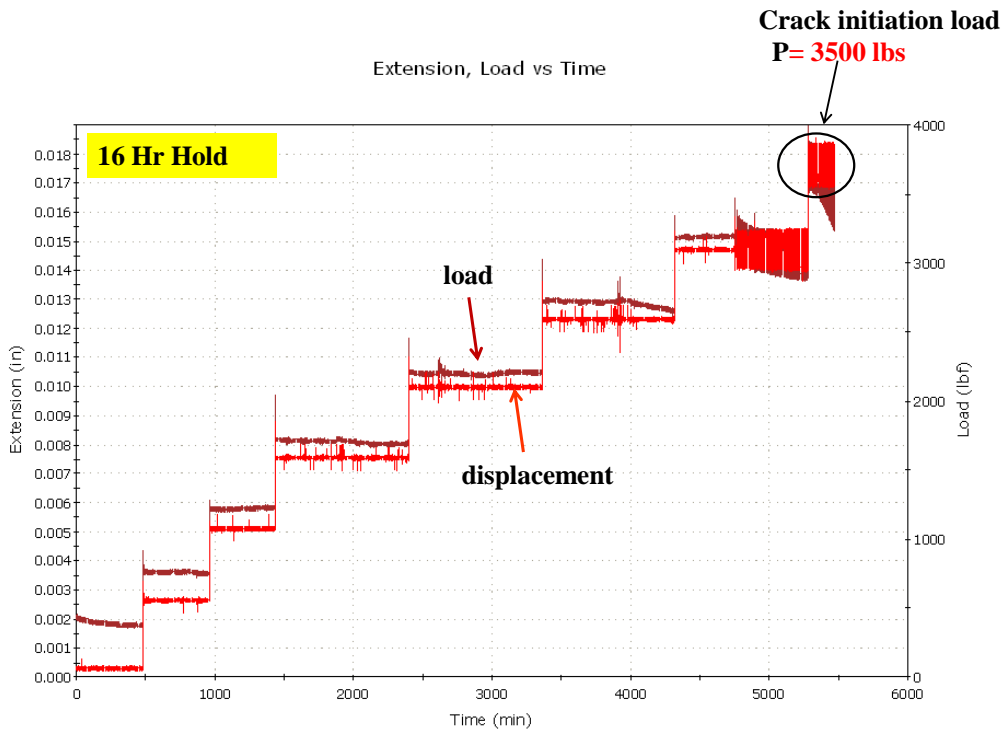

Figure 15e, Rising Step Load, 1&2 hr holding time, results for C465 at 950°F

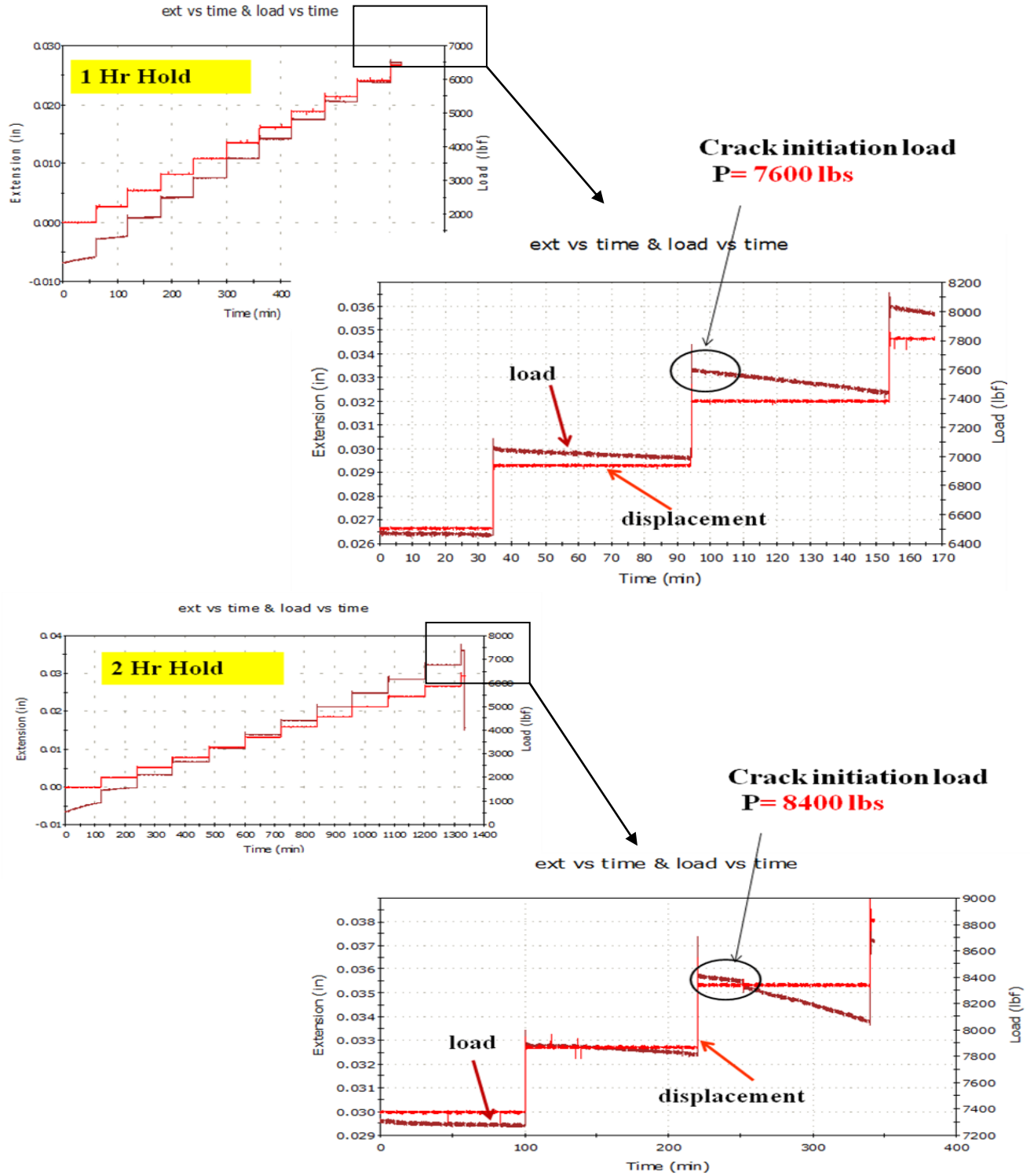

Figure 16 a&b, Rising Step Load, 1&2 hr holding time, results for C465 aged at 1000°F

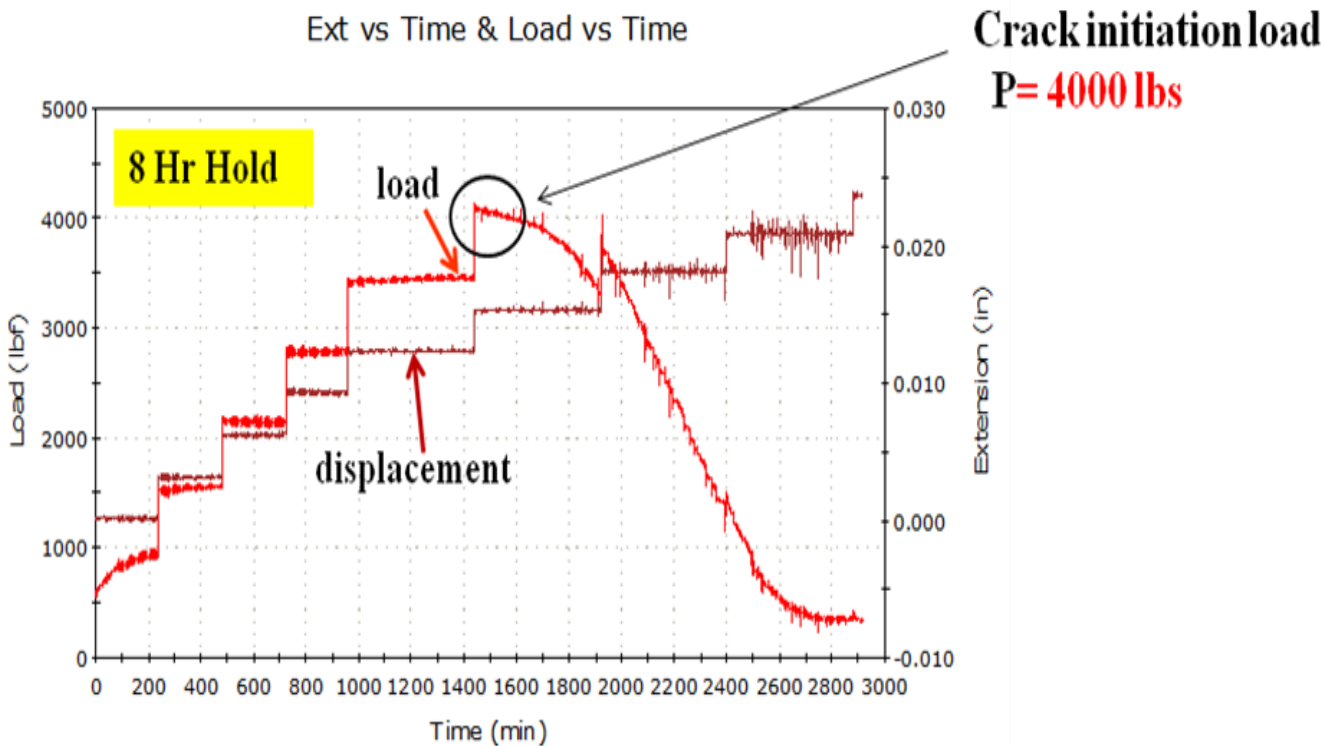
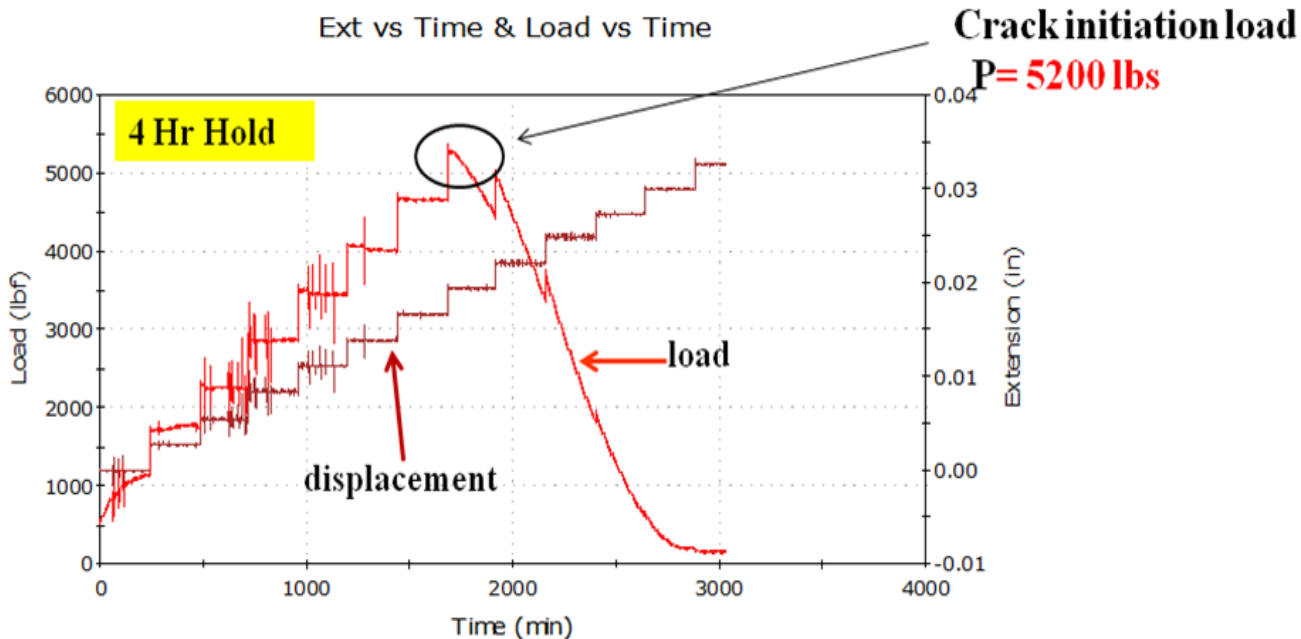

Figure 16 c&d, Rising Step Load, 4&8 hr holding time, results for C465 aged at 1000°F

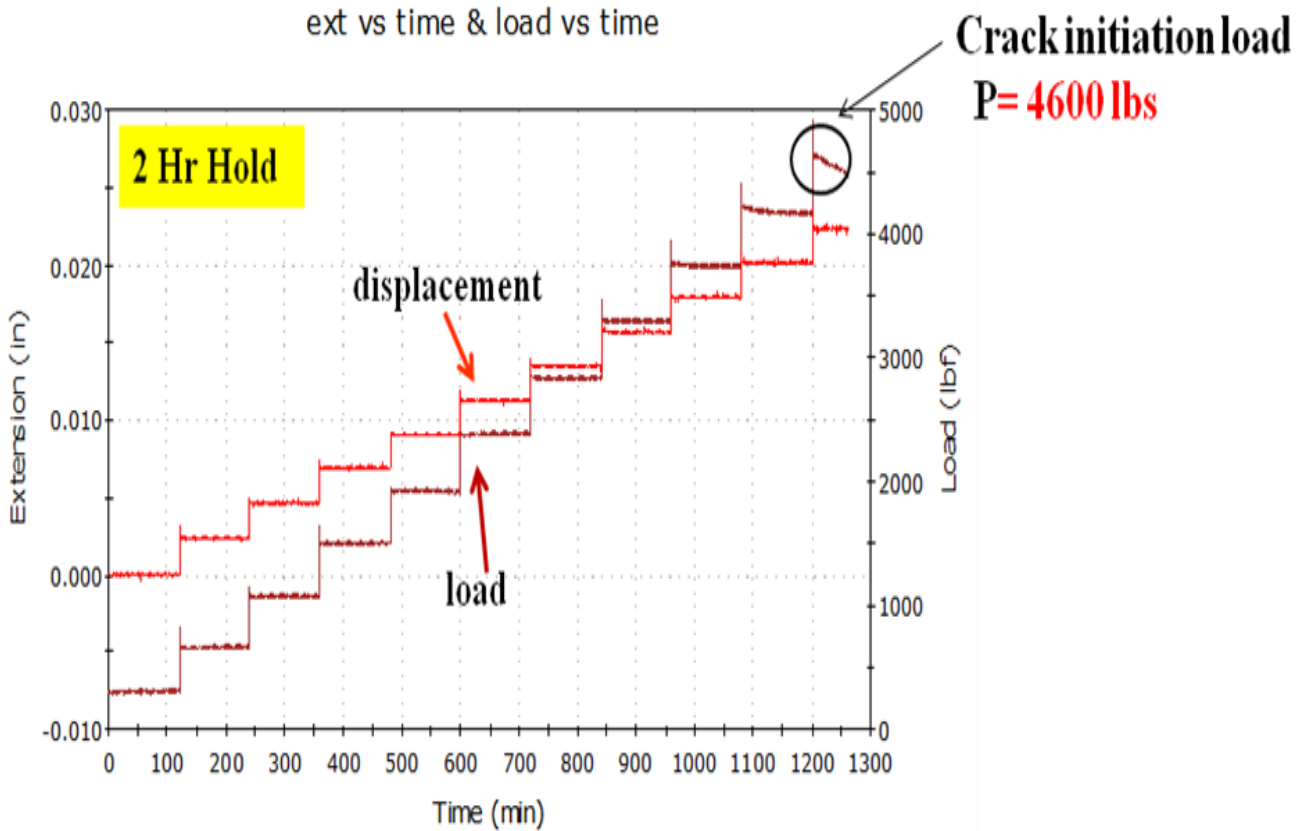
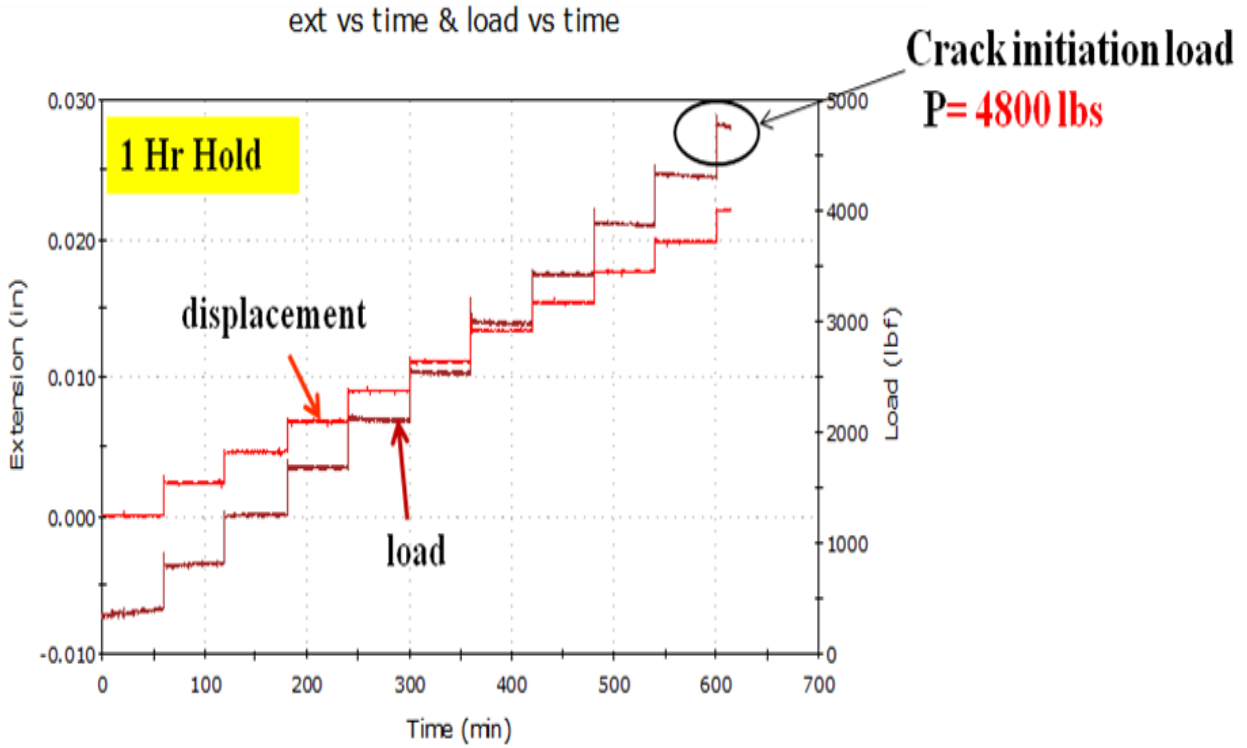

Figure 17 a&b, Rising Step Load, 1&2 hr holding time, results for S53aged at 934°F+900°F

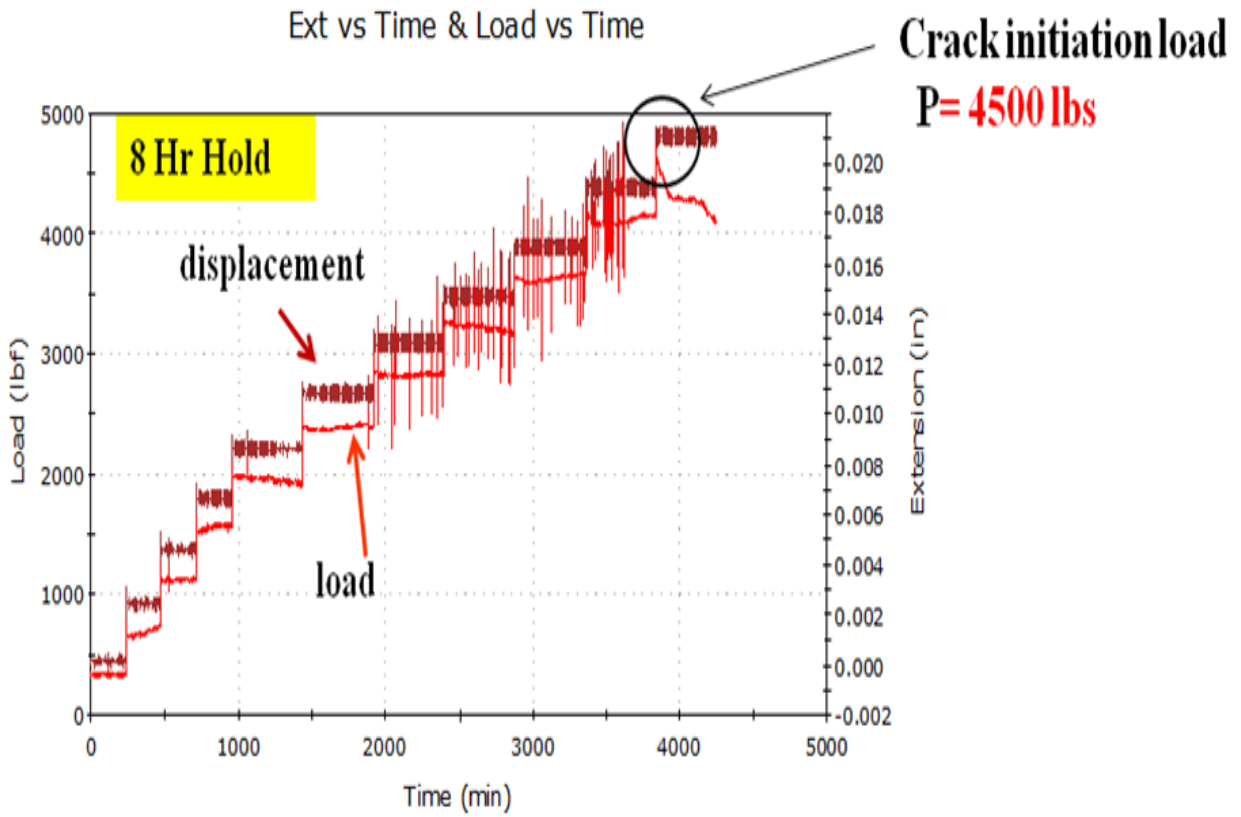
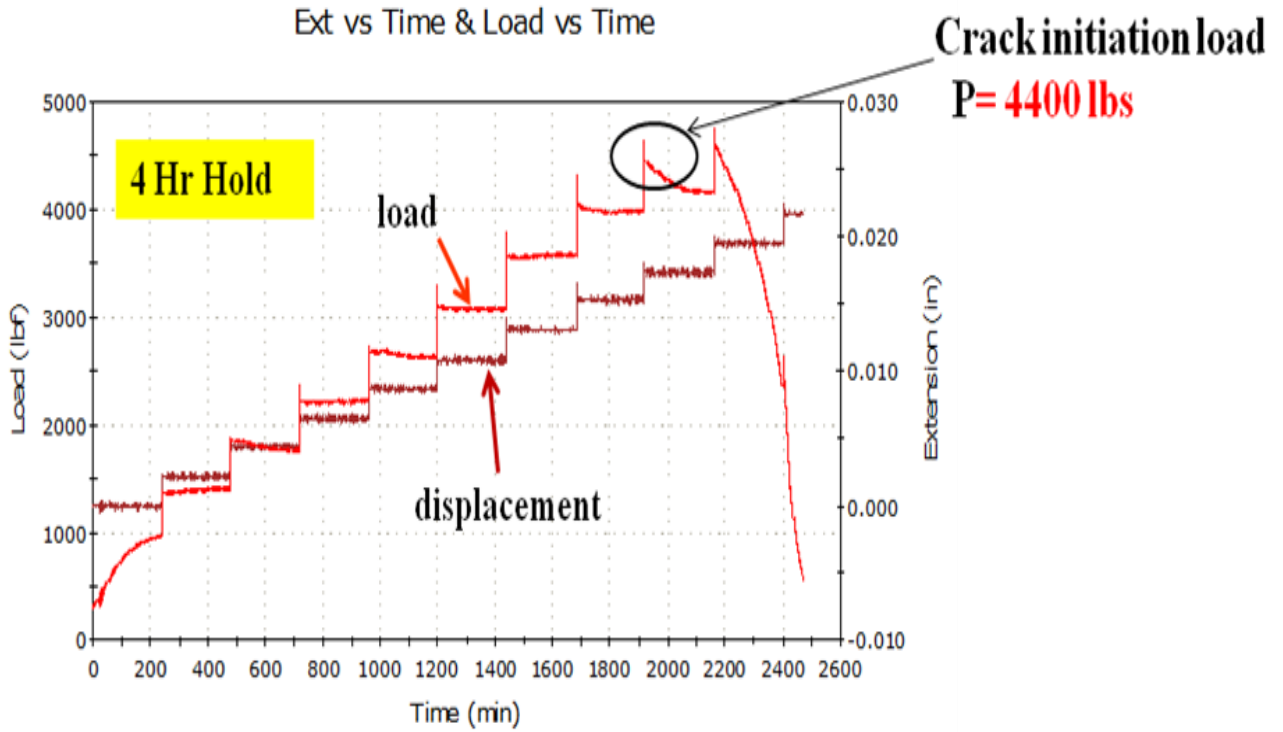

Figure 17 c&d, Rising Step Load, 4&8 hr holding time, results for S53aged at 934°F+900°F

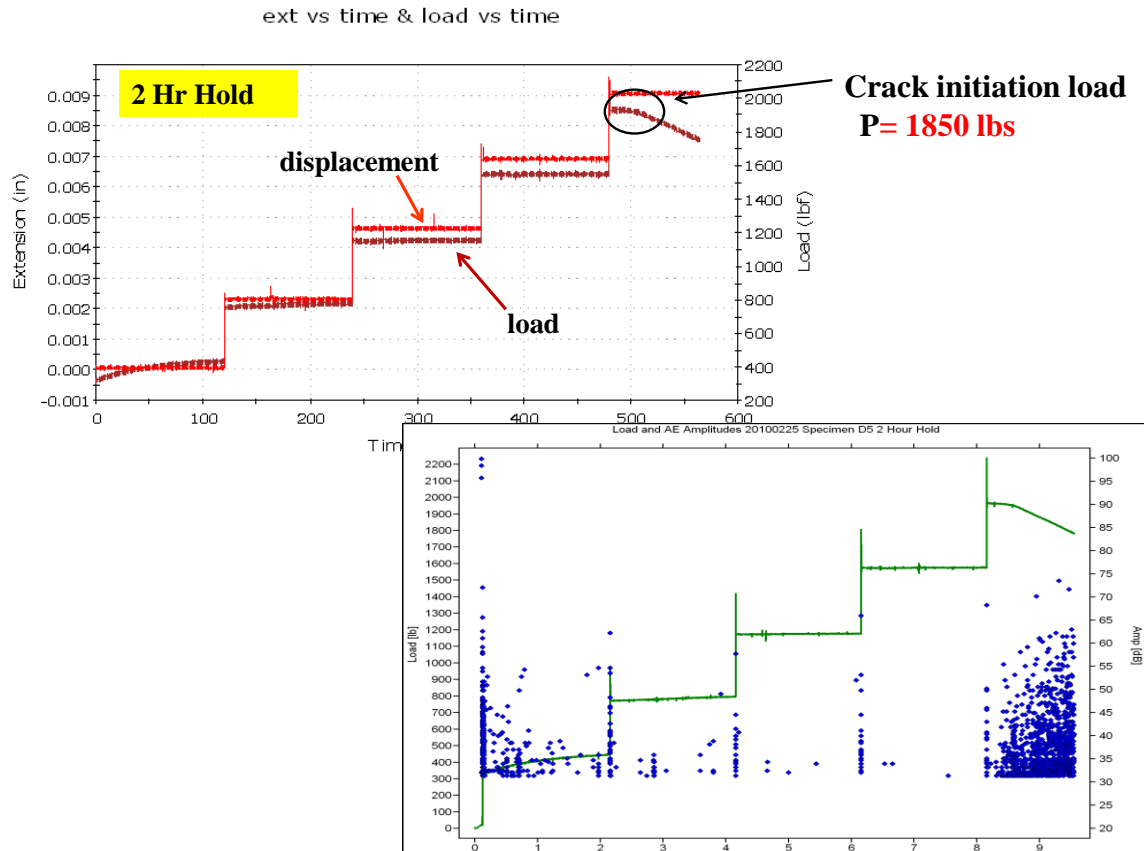

Figure 18 a, Rising step load K_{Isc} test coupled with acoustic emission for 300M tempered at 400°F

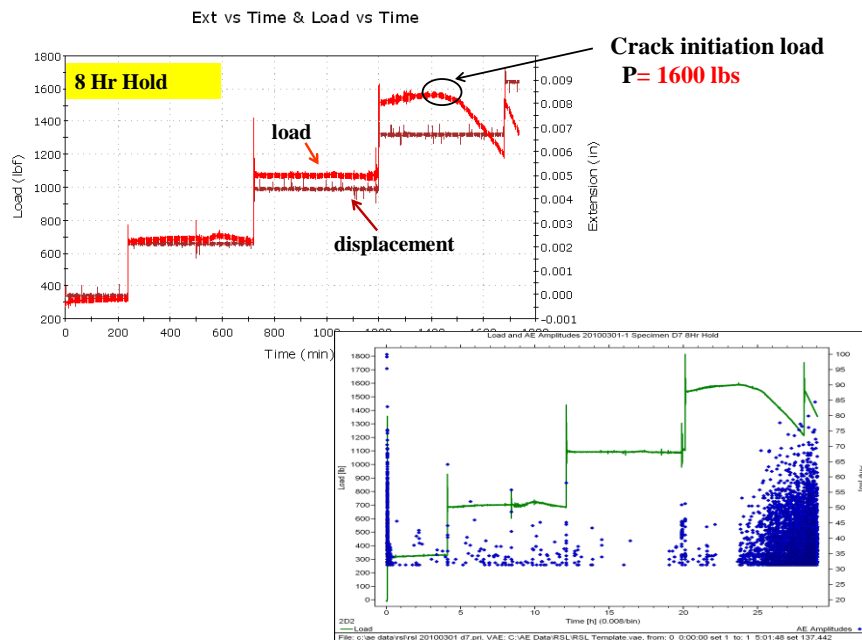

Figure 18b, Rising step load K_{Isc} test coupled with acoustic emission for 300M tempered at 400°F

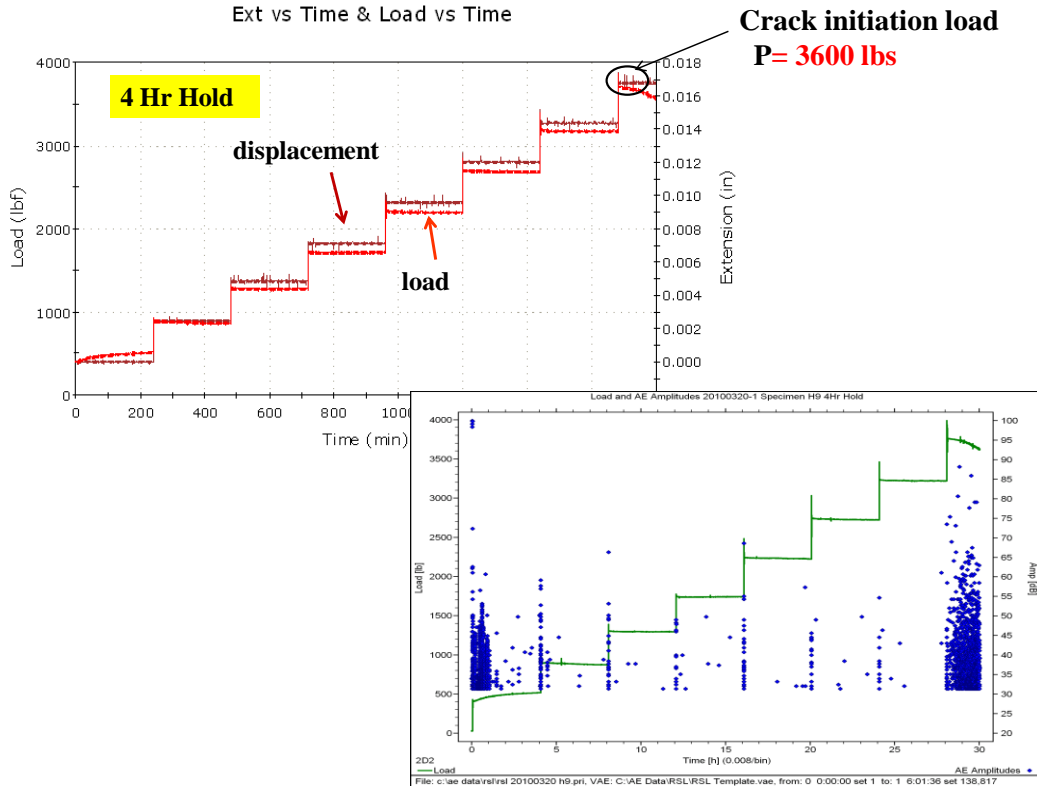

Figure 19, Rising step load K_{Isc} test coupled with acoustic emission for 300M tempered at 575°F

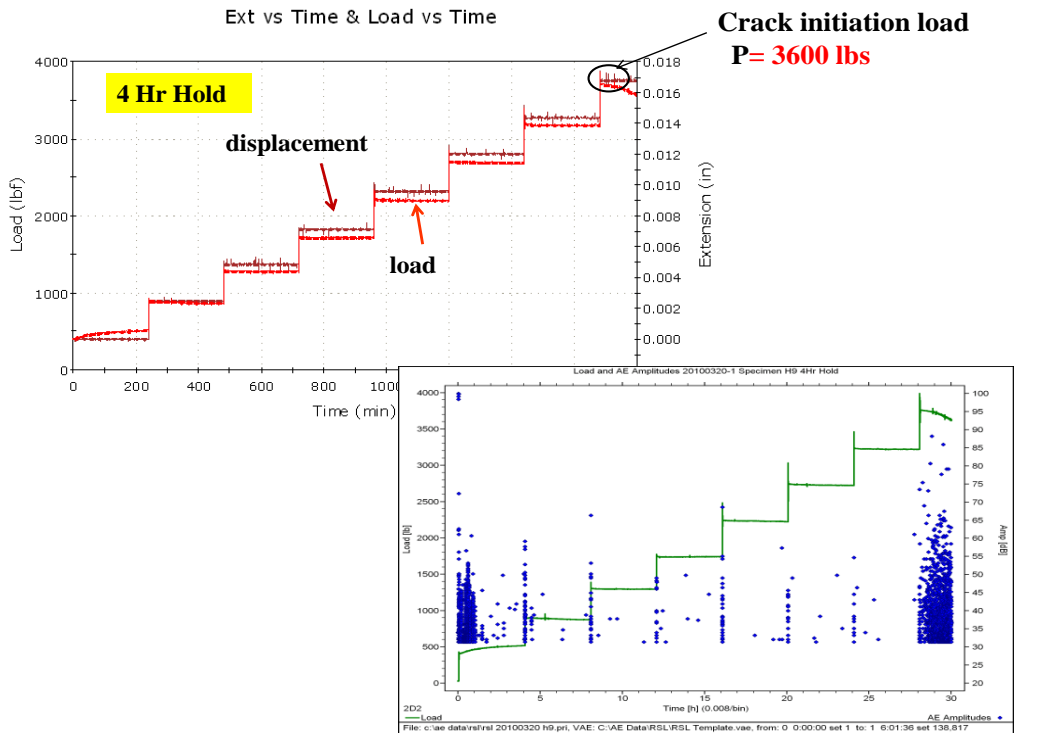

Figure 20a , Rising step load K_{Isc} test coupled with acoustic emission for C465 aged at 950°F

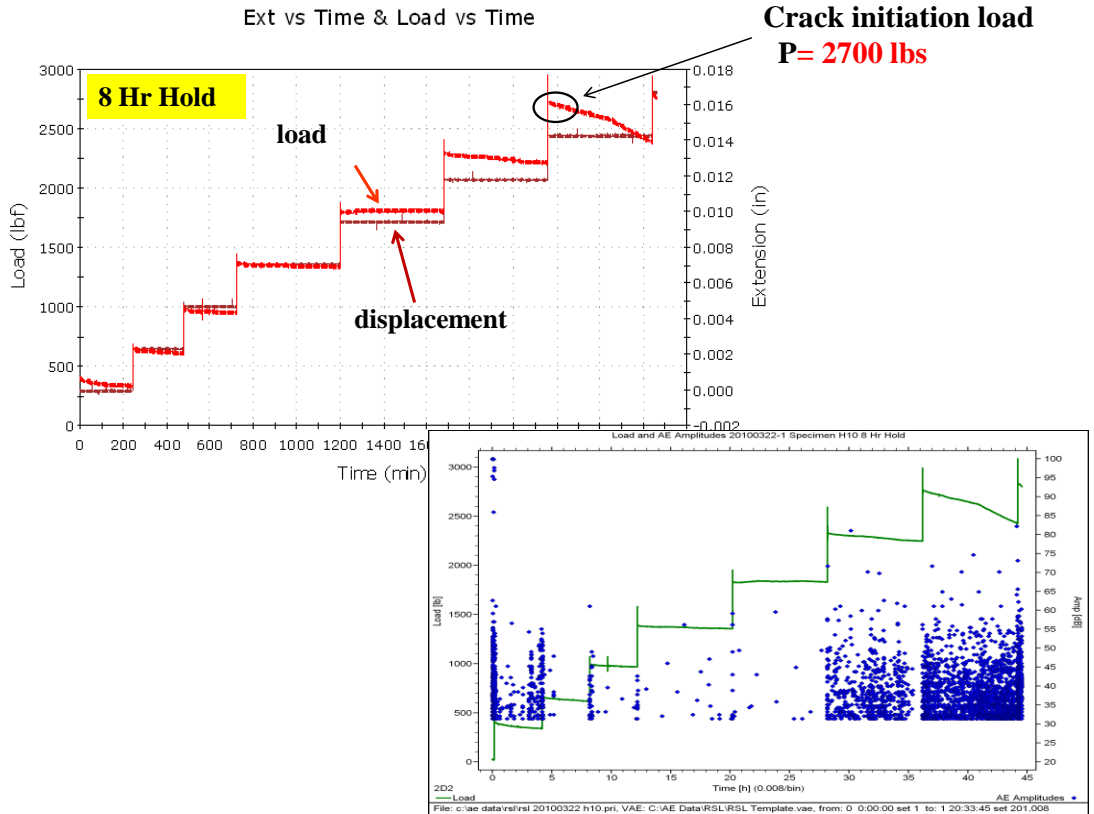

Figure 20b , Rising step load K_{Isc} test coupled with acoustic emission for C465 aged at 950°F

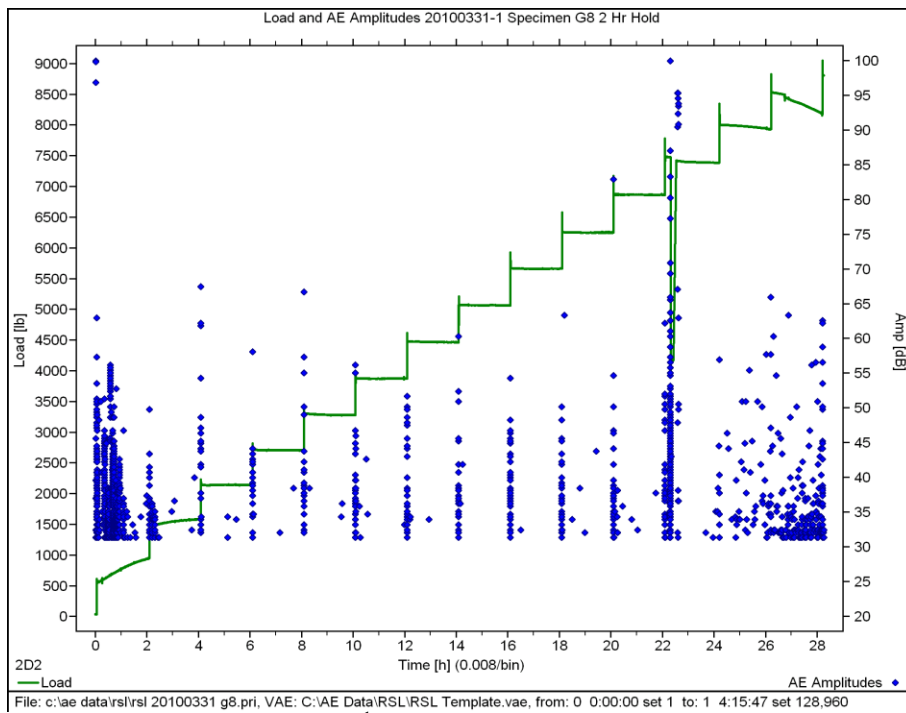

Figure 21, Rising step load K_{Isc} test coupled with acoustic emission for C465 aged at 1000°F, 2hr hold

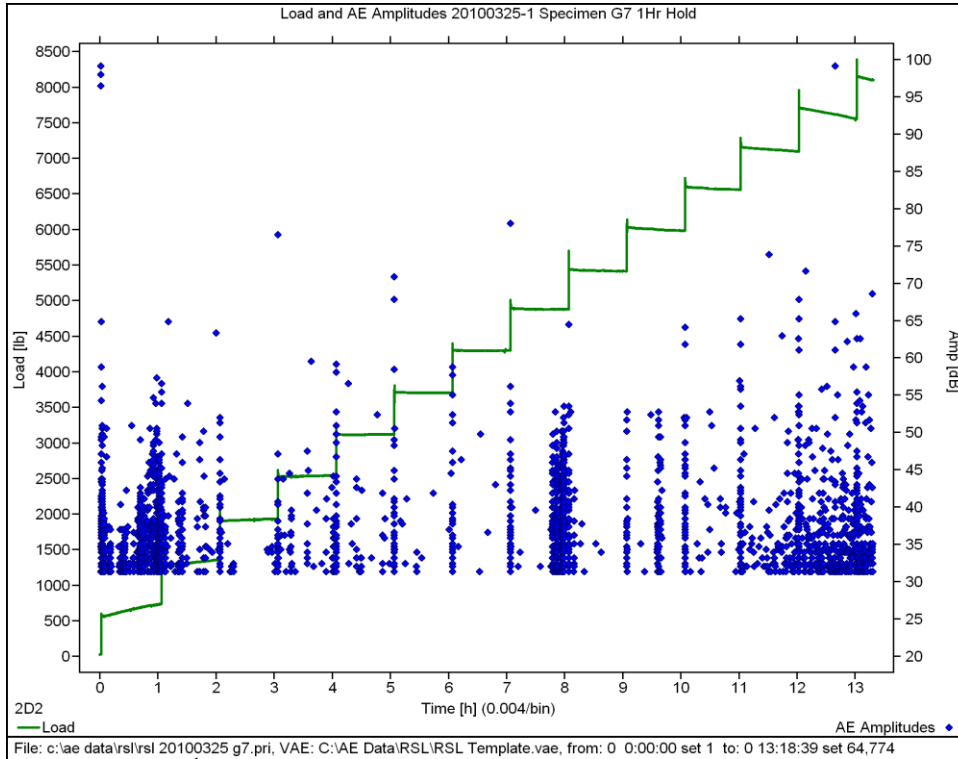

Figure 22, RSL, $K_{I_{sc}}$ test coupled with AE for C465 aged at 1000°F, 1hr hold
ext vs time & load vs time

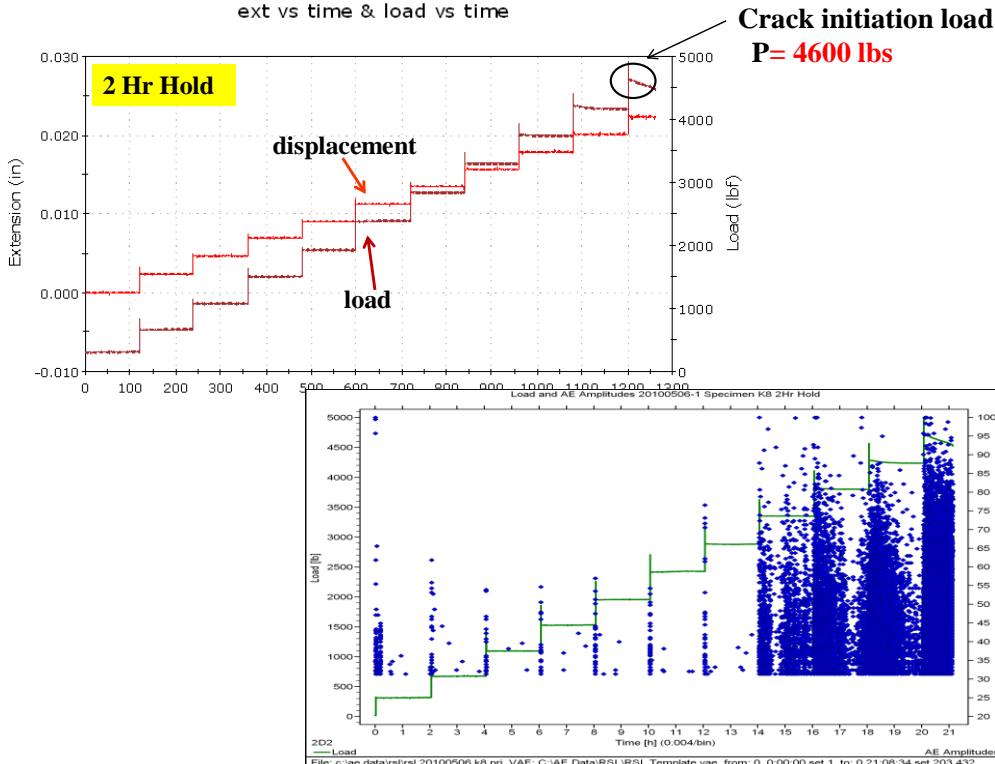

Figure 23, RSL, $K_{I_{sc}}$ test coupled with AE for S53 tempered at 934°F & 900°F, 2hr hold

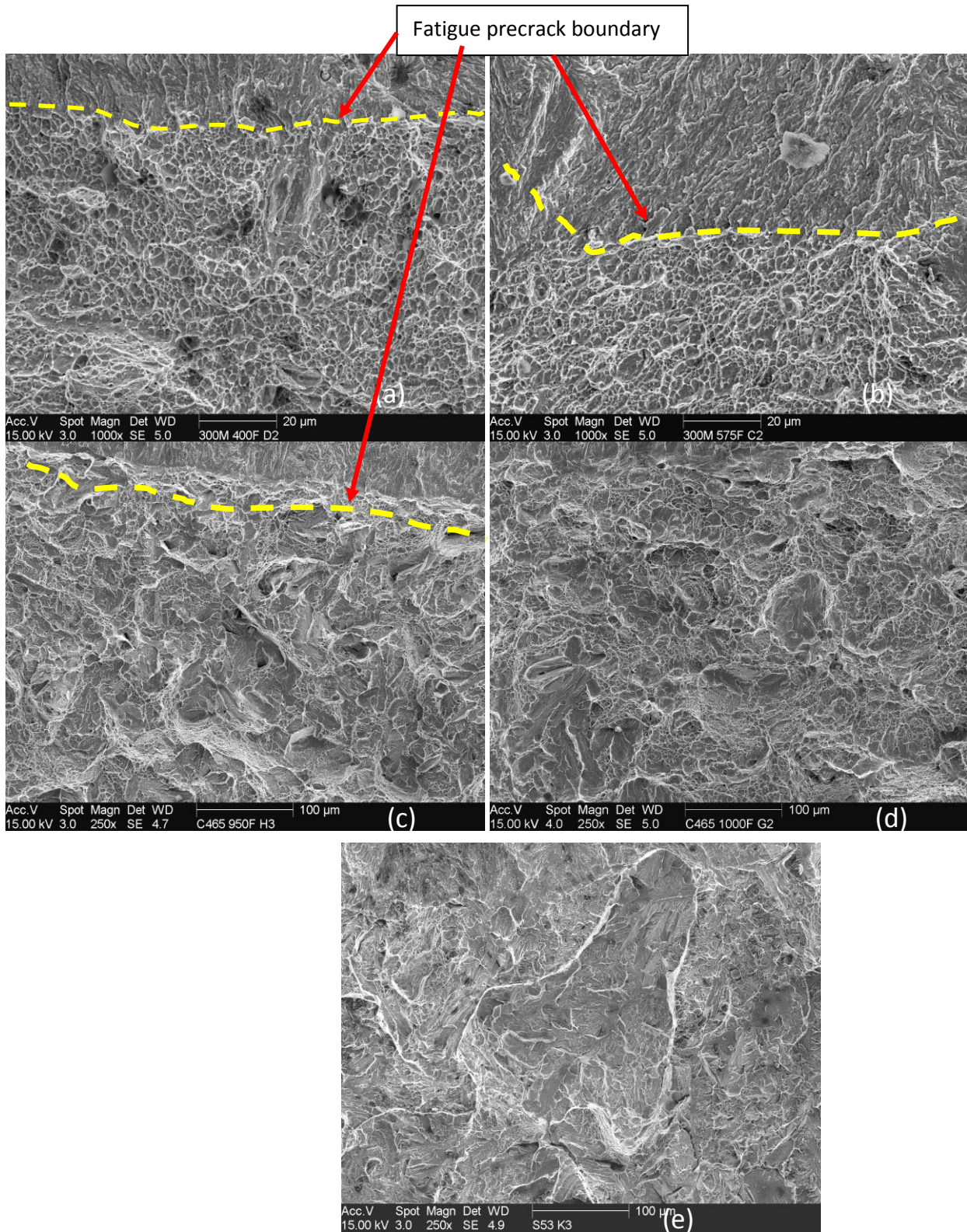

Figure 24 SEM Fractographs of K1c specimens, showing fatigue precrack and crack initiation zones for (a) 300M tempered at 400oF, (b) 300M tempered at 575oF, (c) C465 aged at 950oF, (d) C465 aged at 1000oF and (e) S53 aged at 934oF and 900oF; variable magnifications

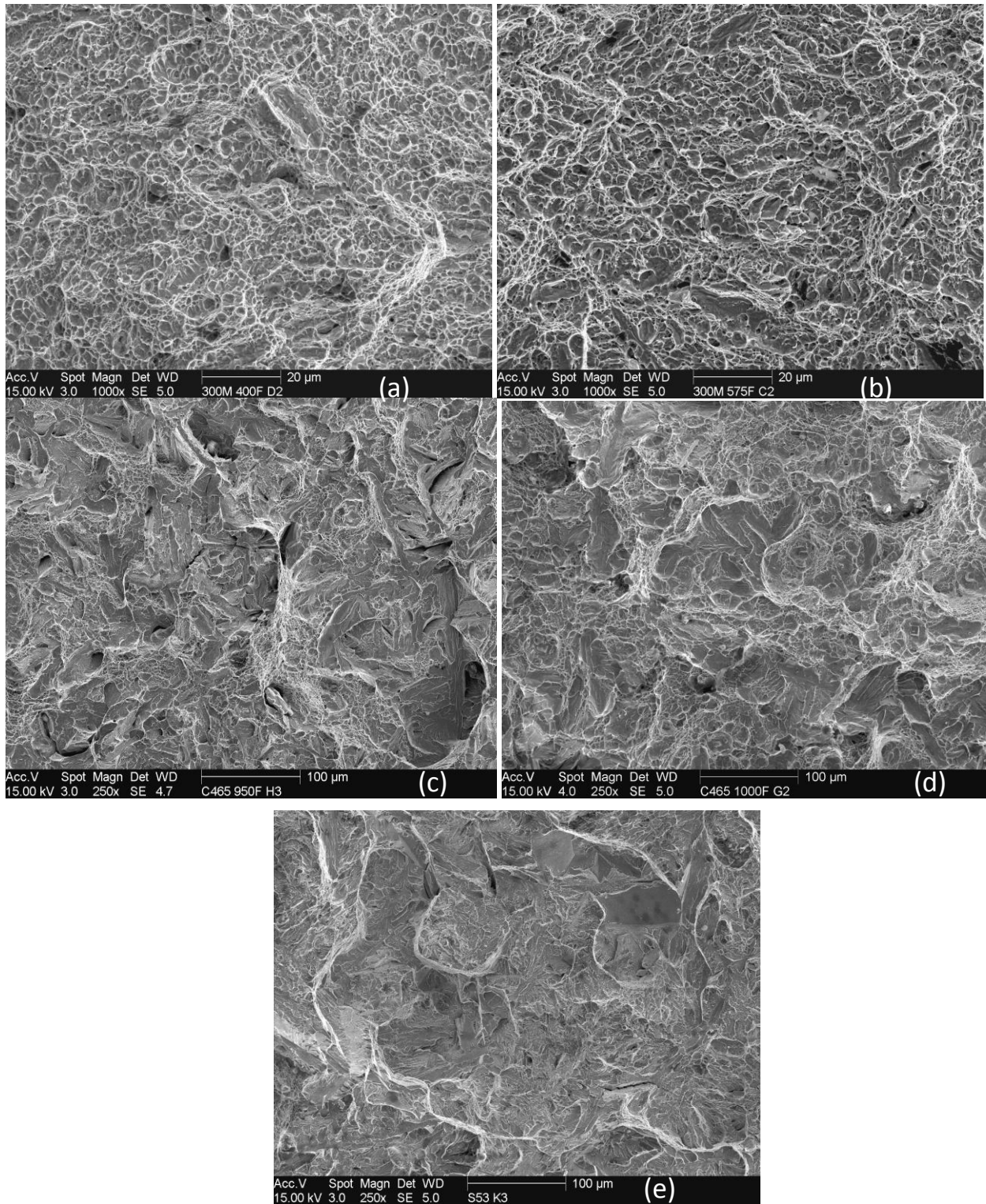

Figure 25: SEM fractographs of K_{1c} specimens, showing crack initiation zones for (a) 300M tempered at 400°F, (b) 300M tempered at 575°F, (c) C465 aged at 950°F, (d) C465 aged at 1000°F and (e) S53 aged at 934°F and 900°F; variable magnifications

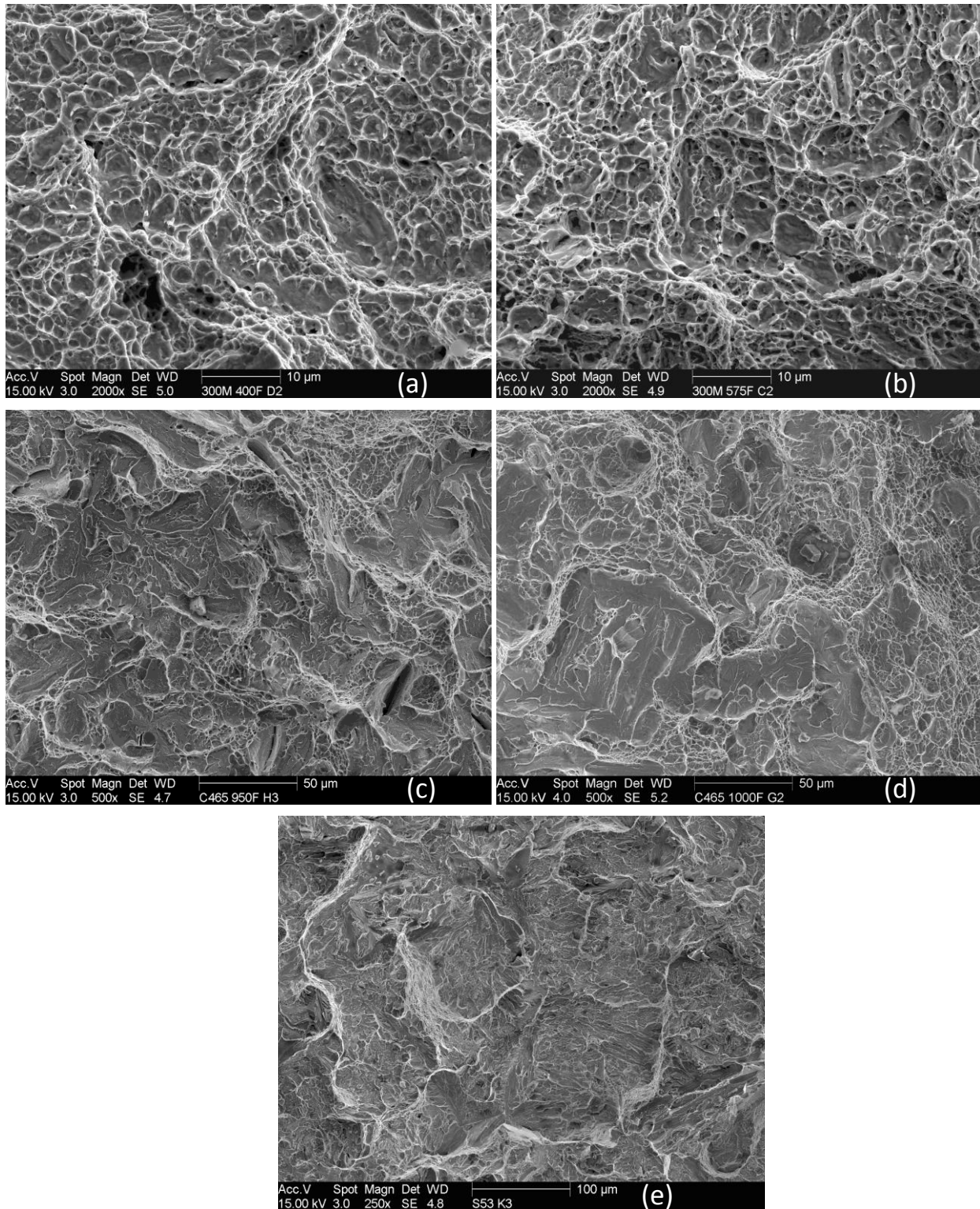

Figure 26: SEM fractographs of K_{Ic} Specimens, comparing dimple size and distribution (a) 300M tempered at 400°F, (b) 300M tempered at 575°F, (c) C465 aged at 950°F, (d) C465 aged at 1000°F and (e) S53 aged at 934°F and 900°; variable magnifications

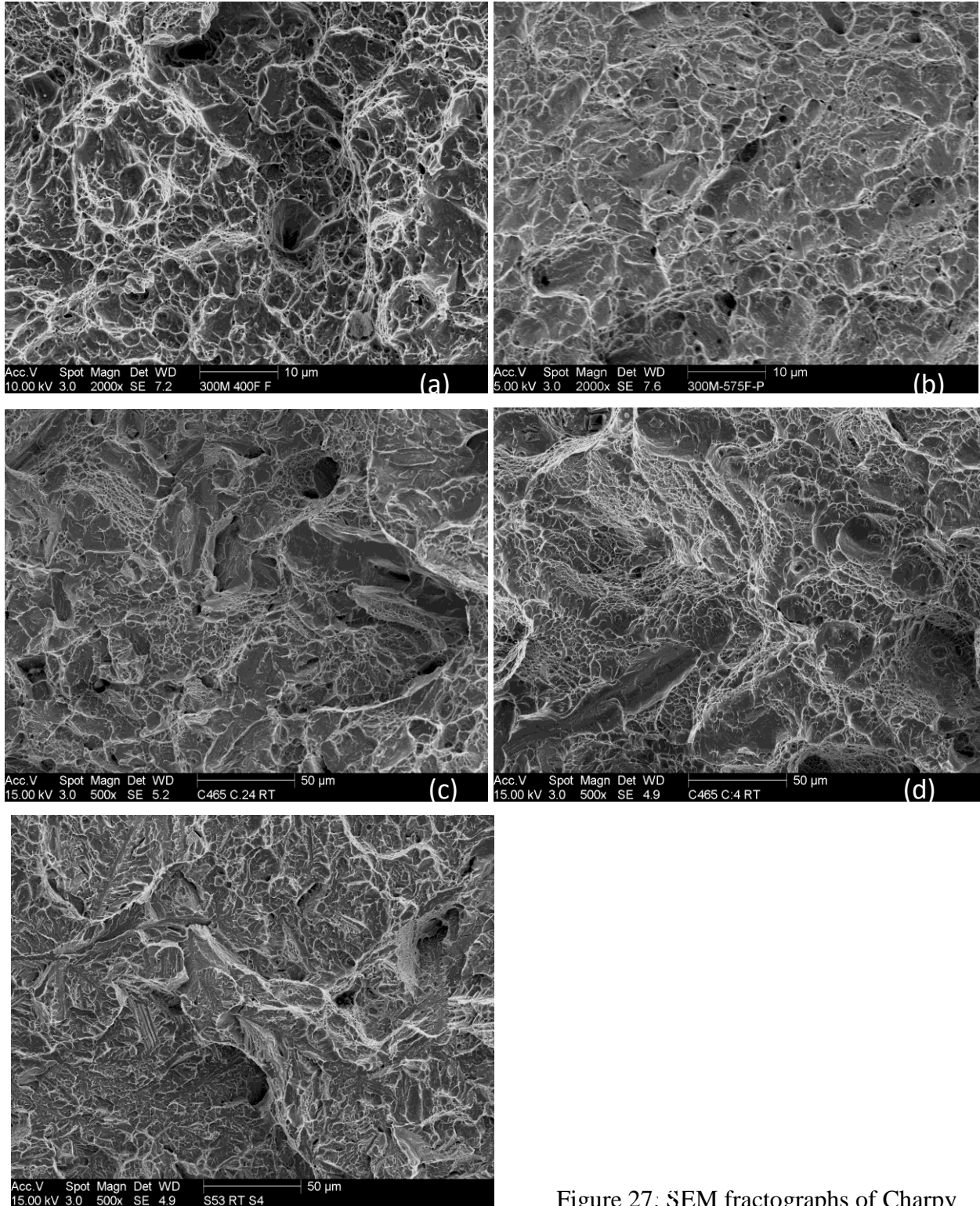

Figure 27: SEM fractographs of Charpy impact toughness specimens, (a) 300M tempered at 400°F, (b) 300M tempered at 575°F, (c) C465 aged at 950°F, (d) C465 aged at 1000°F and (e) S53 aged at 934°F and at 900°F; variable magnifications

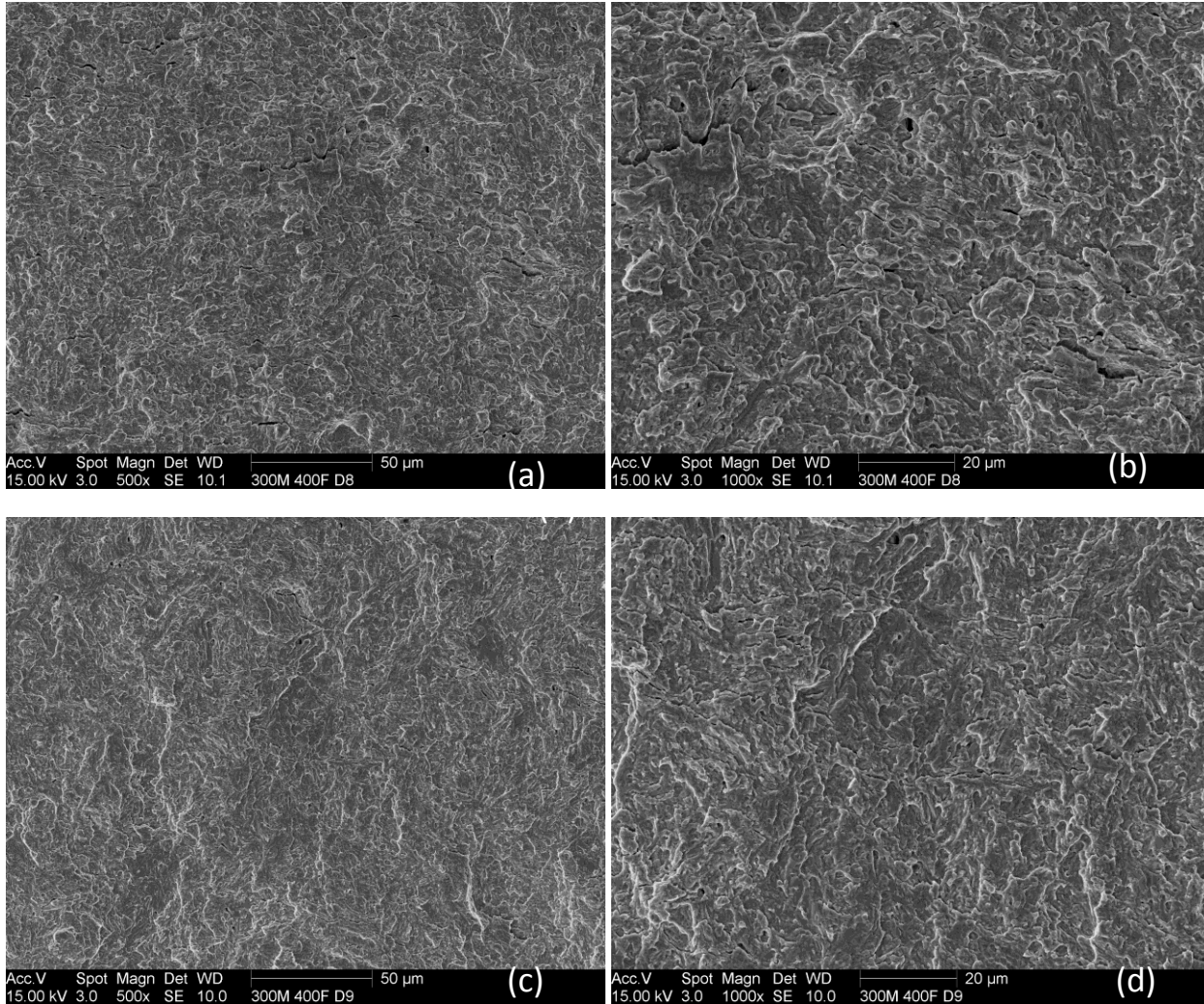
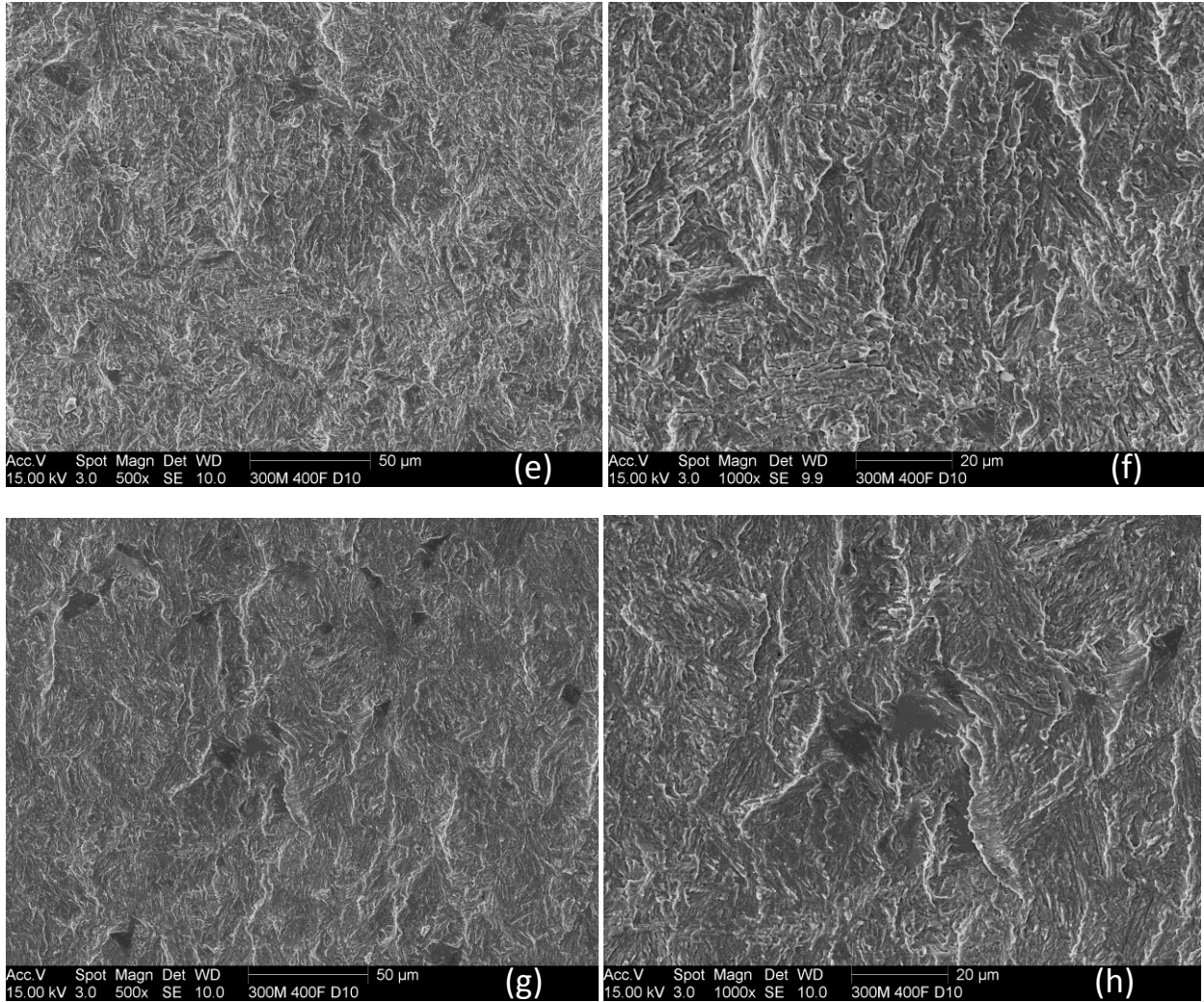

Figure 28: SEM fractographs of da/dn tested 300M tempered at 400°F
 (a) and (b) $\Delta K = 40 \text{ ksi-in}^{1/2}$ (c) and (d) $\Delta K = 28 \text{ ksi-in}^{1/2}$



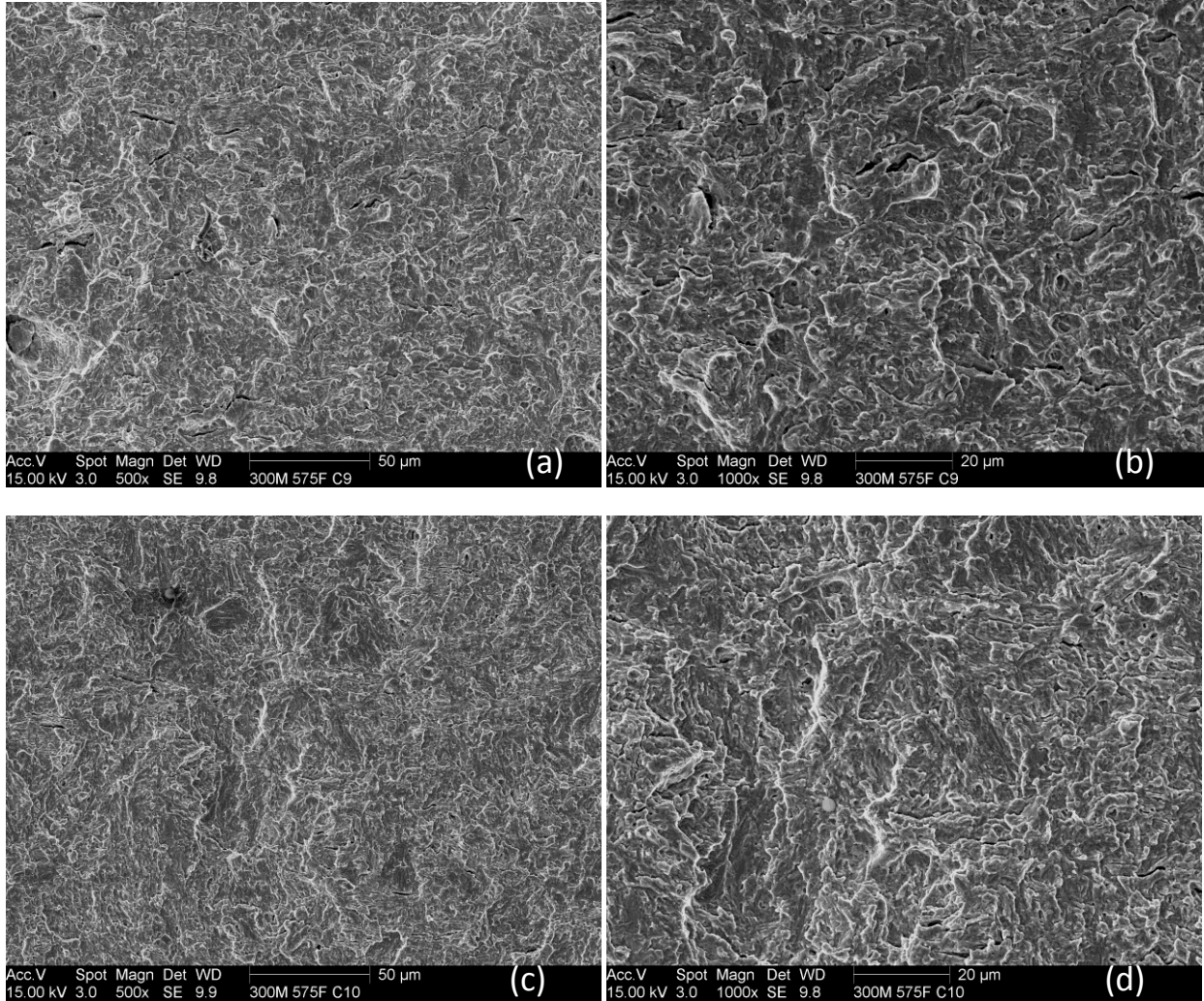
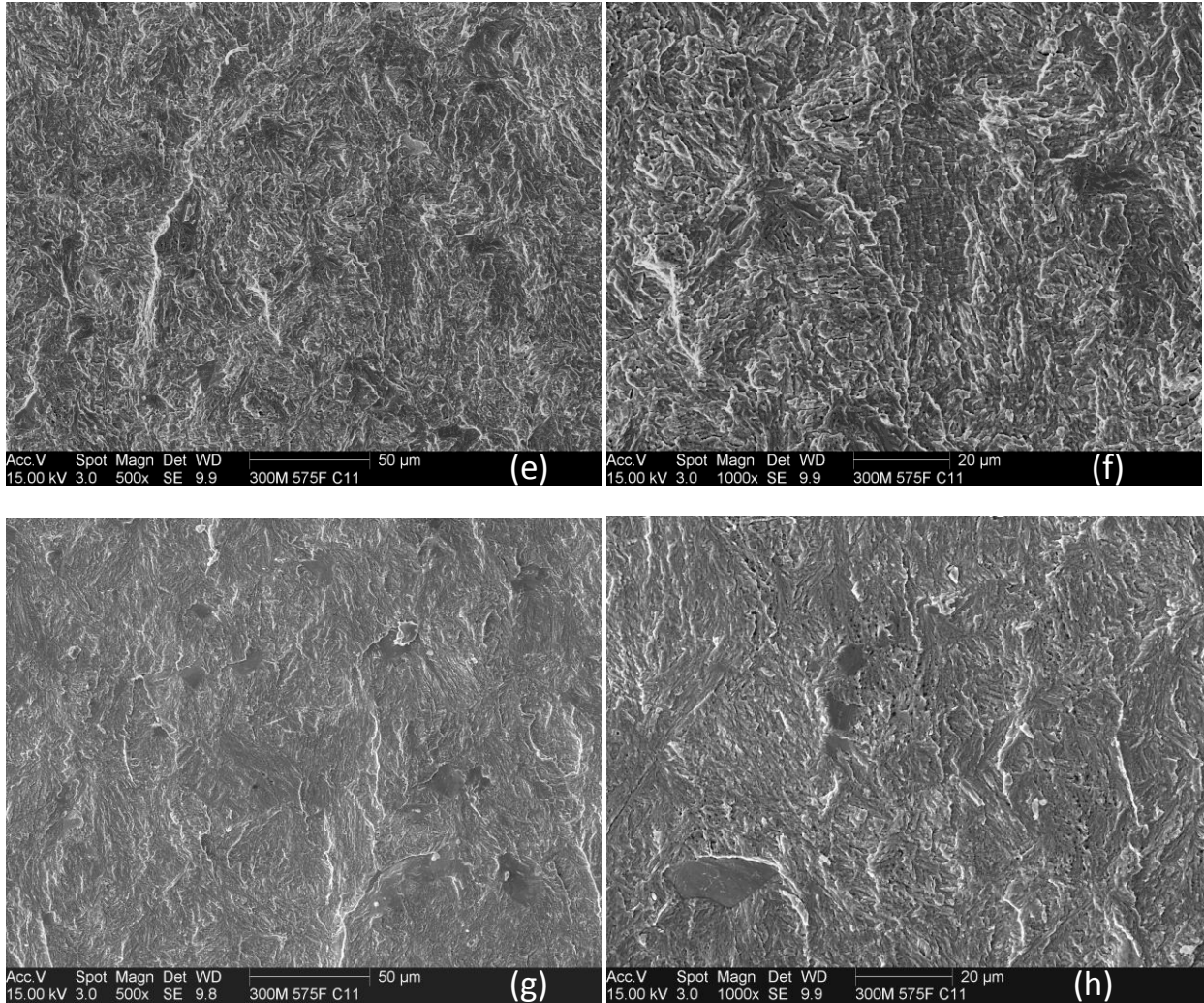

Figure 29: SEM fractographs da/dn tested 300M tempered at 575°F
 (a) and (b) $\Delta K = 42 \text{ ksi-in}^{1/2}$ (c) and (d) $\Delta K = 30 \text{ ksi-in}^{1/2}$



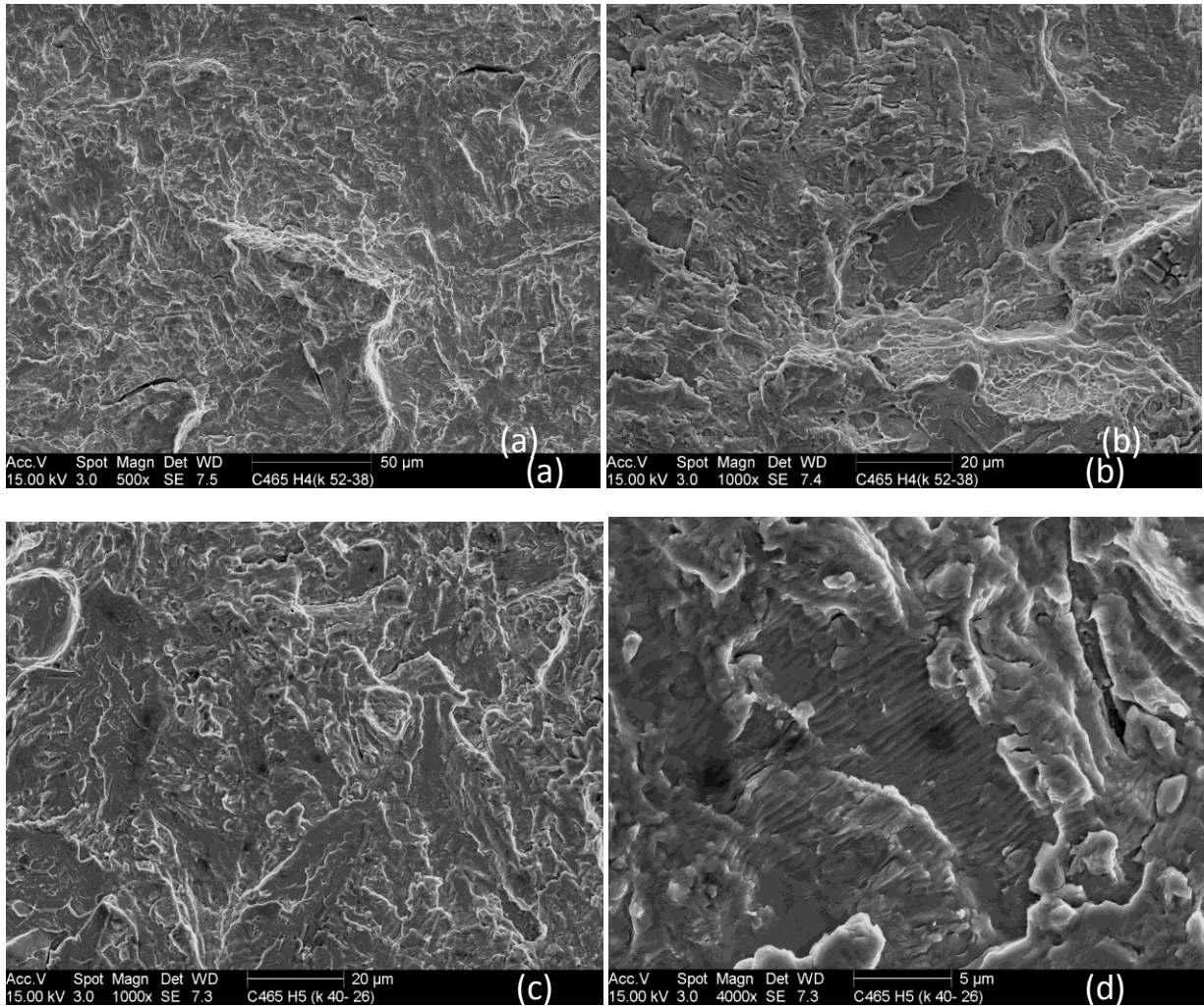
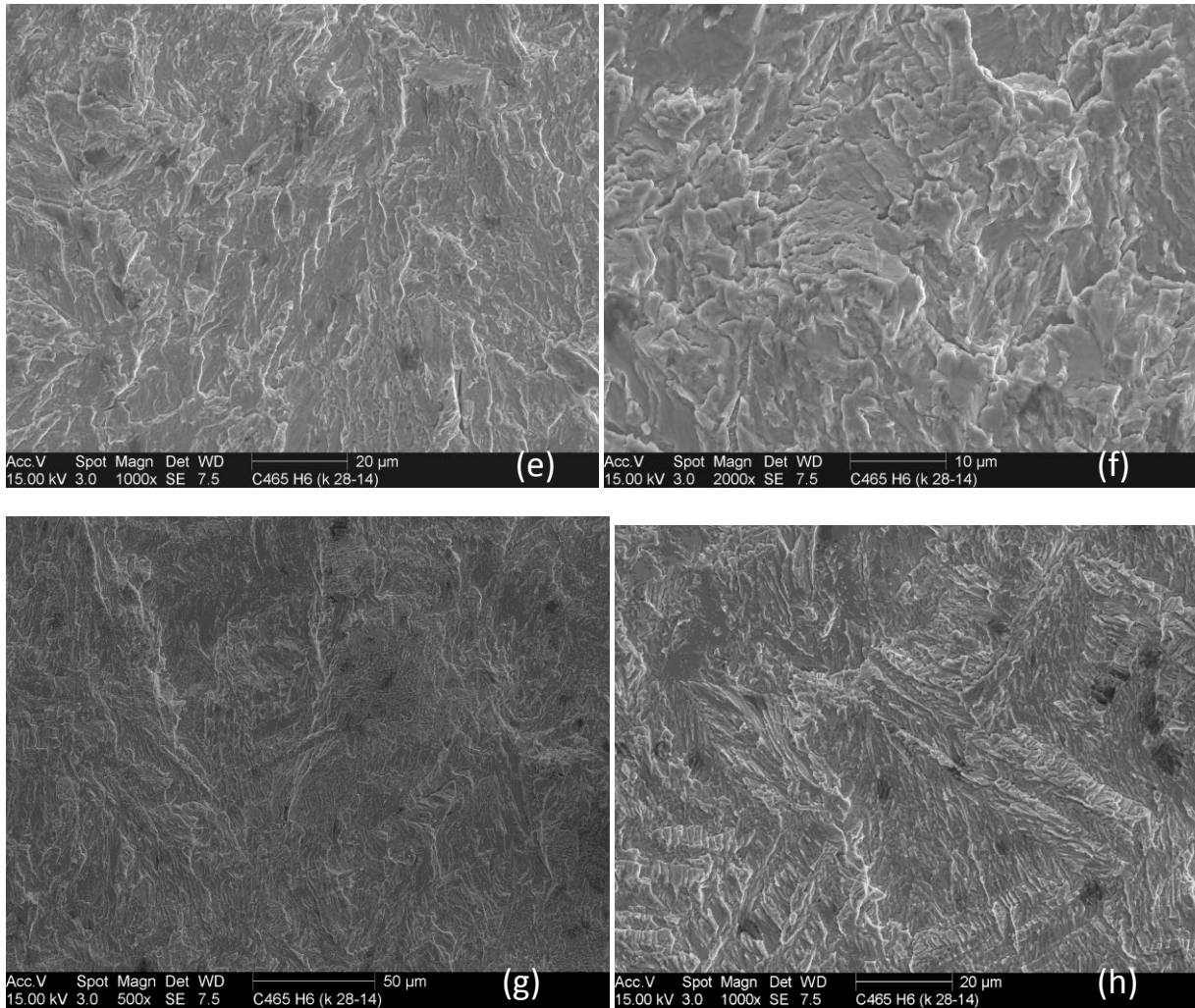

Figure 30: SEM fractographs of da/dn tested C465 Aged at 950°F
 (a) and (b) $\Delta K = 52 \text{ ksi-in}^{1/2}$ (c) and (d) $\Delta K = 40 \text{ ksi-in}^{1/2}$



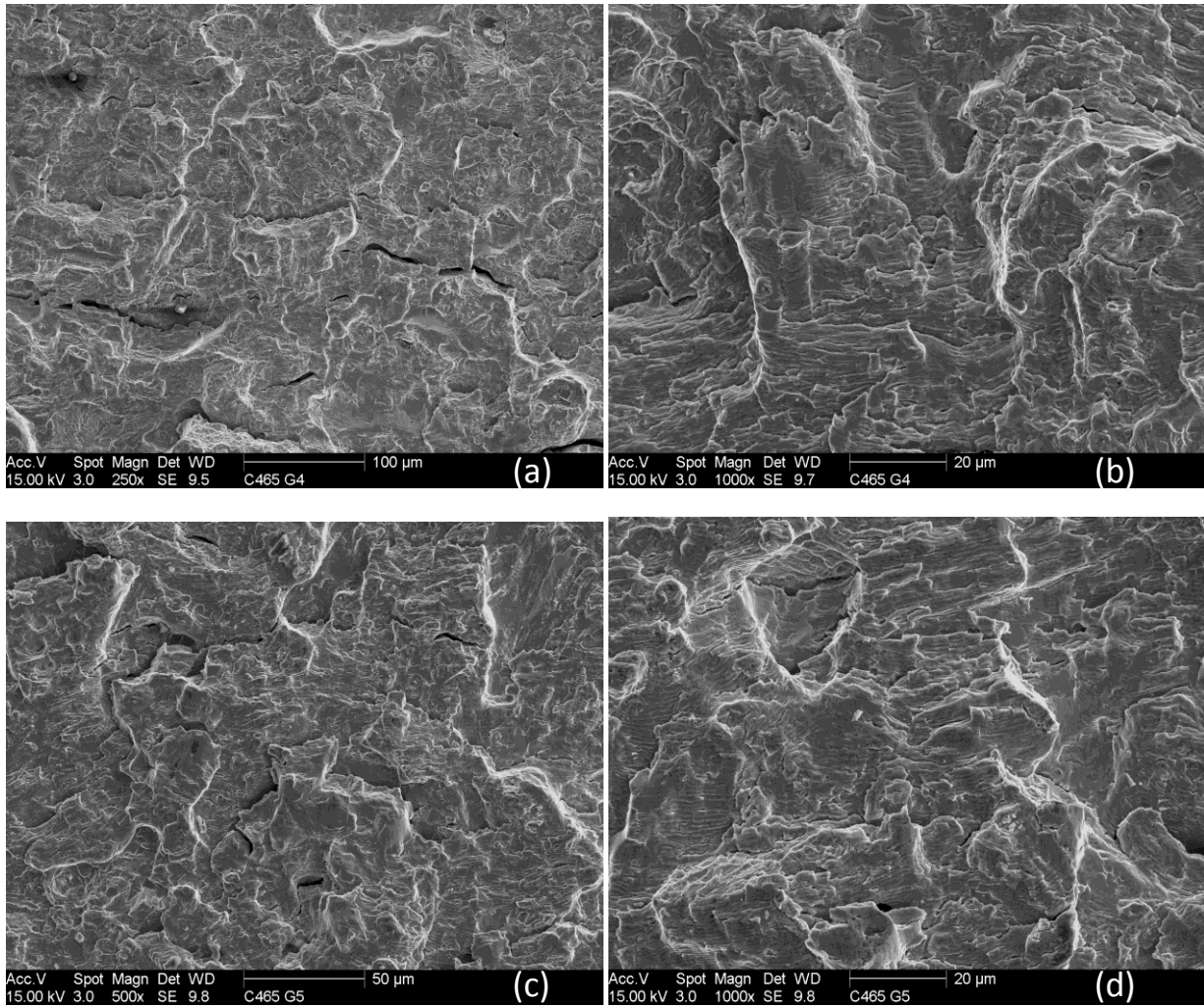
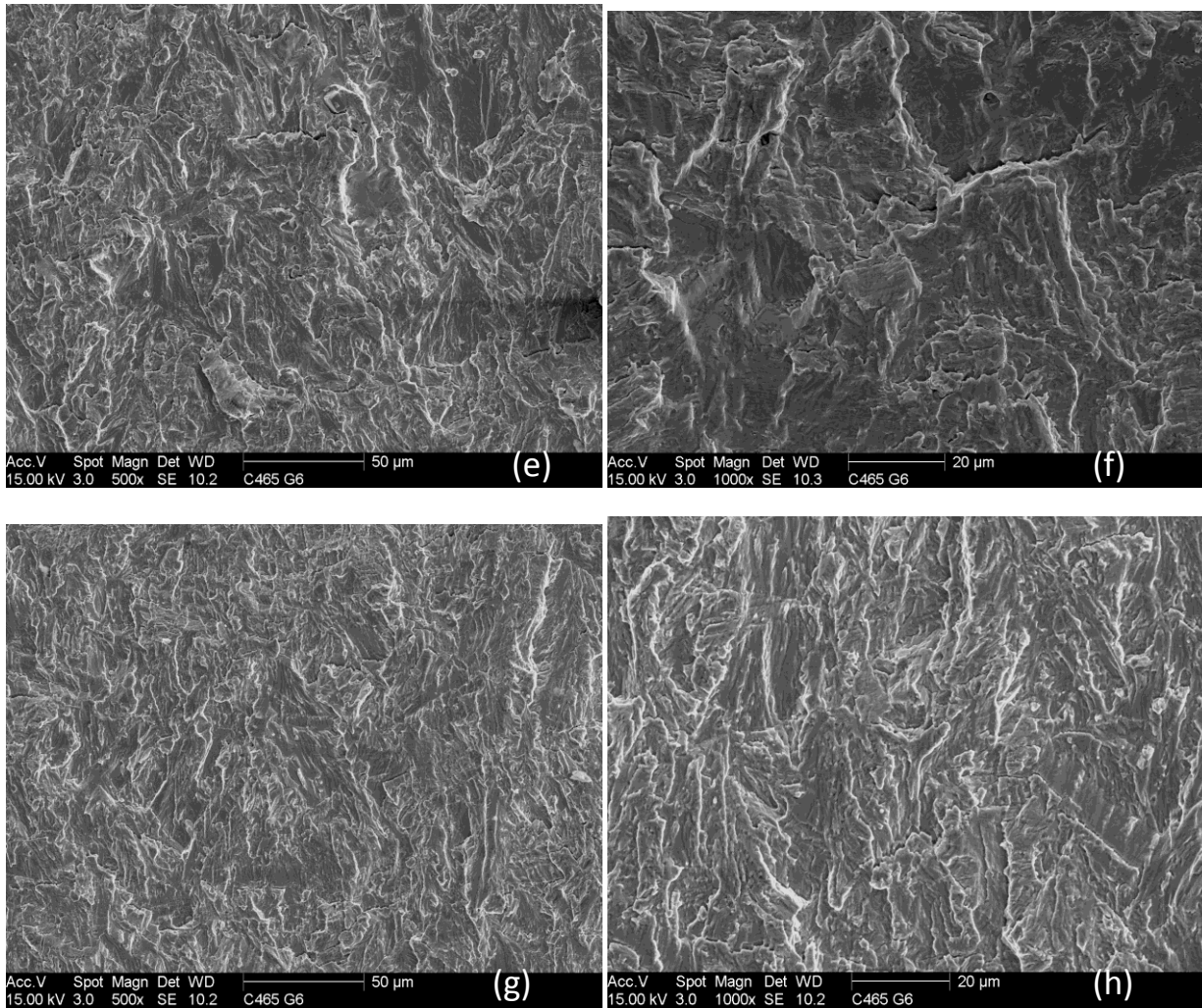

Figure 31: SEM fractographs of da/dn tested C465 Aged at 1000°F
(a) and (b) $\Delta K = 90 \text{ ksi-in}^{1/2}$ **(c) and (d)** $\Delta K = 66 \text{ ksi-in}^{1/2}$



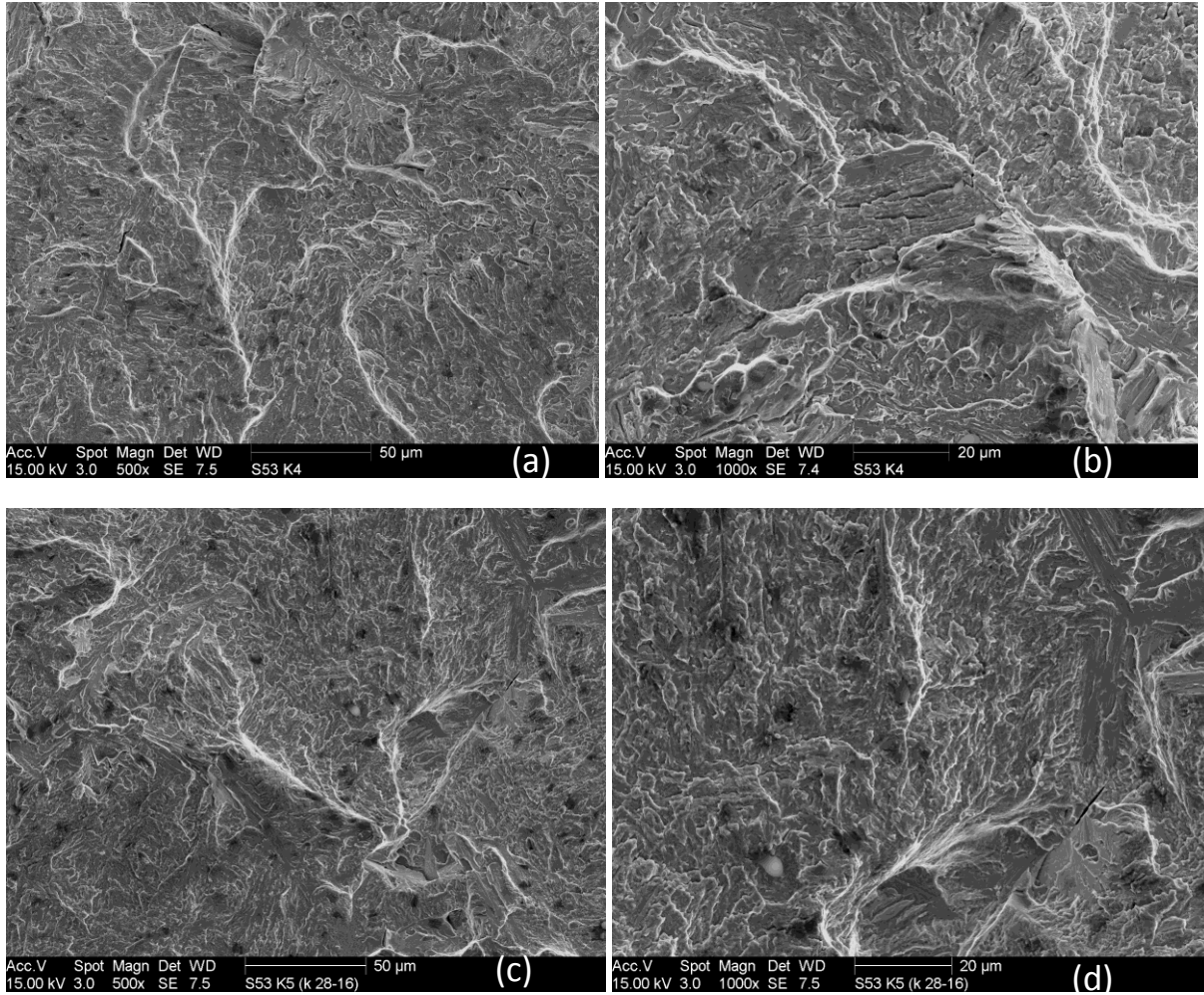
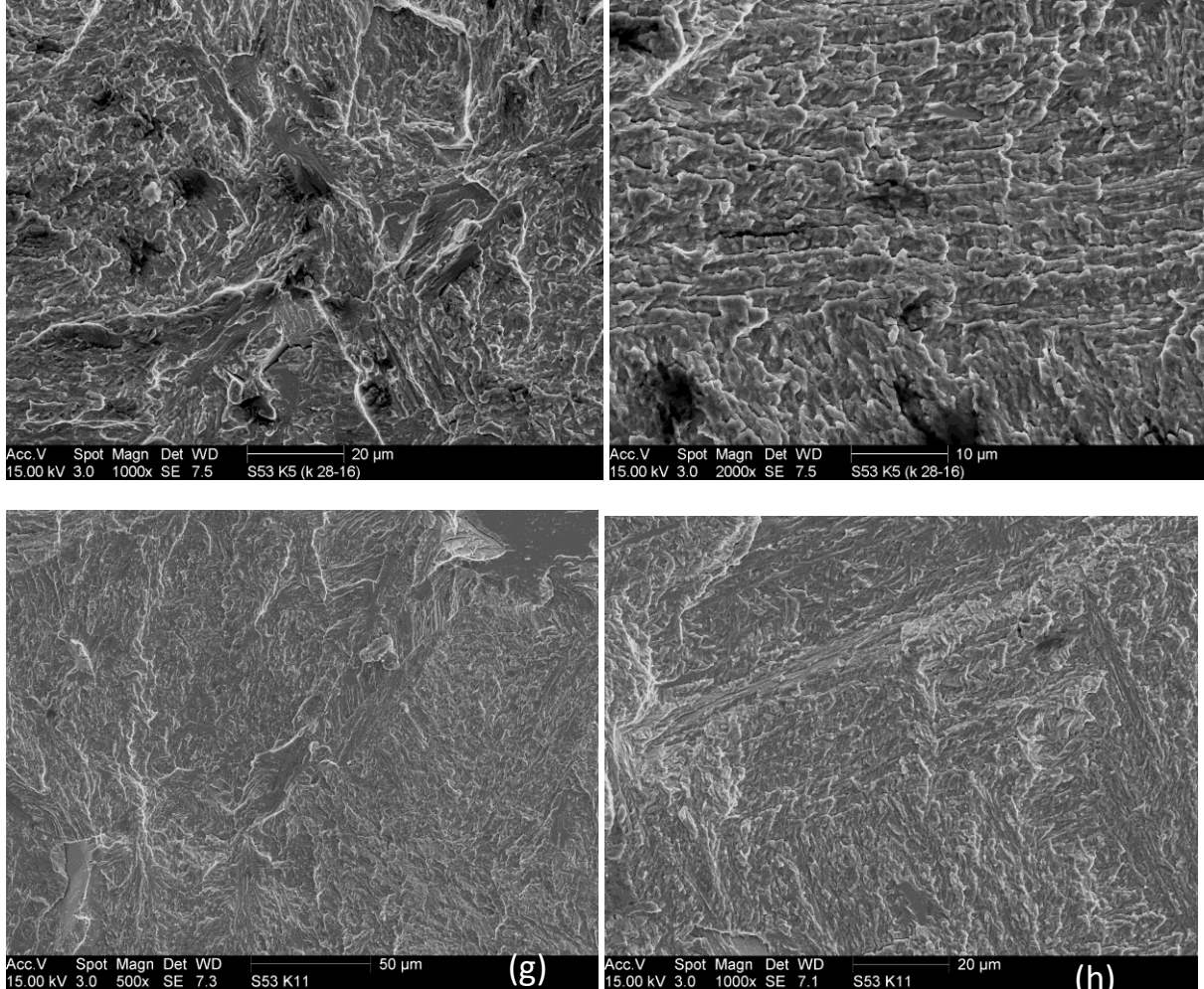

Figure 32: SEM fractographs of da/dn tested S53 Aged at 934°F and 900°F
 (a) and (b) $\Delta K = 38 \text{ ksi-in}^{1/2}$ (c) and (d) $\Delta K = 28 \text{ ksi-in}^{1/2}$



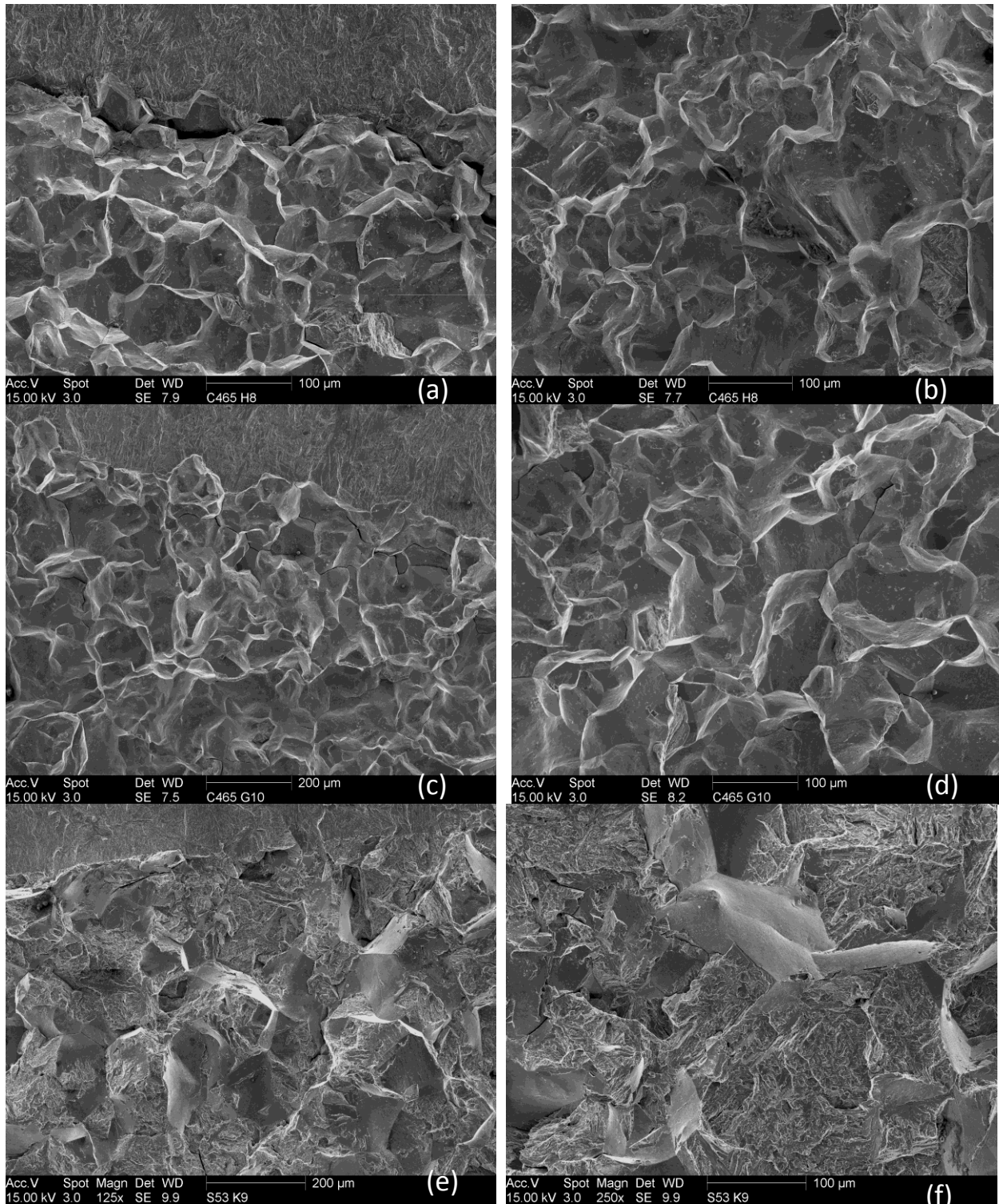

Figure 33: SEM fractographs of RSL K_{Isc} specimens showing intergranular failure in C465 aged at 950°F and at 1000°F, (a-d); and mixed intergranular and transgranular quasicleavage in S53 aged at 934°F and 900°F, (e) and (f).

Appendix D – Worksystems Inc. Final Report

**Army Research Laboratory
NW Manufacturing Initiative Final Report
Submitted By: Worksystems, Inc.**

**Executive Summary
NW Manufacturing Initiative Grants:**

Worksystems, Inc. (WSI) is a nonprofit organization serving the City of Portland, Multnomah and Washington counties. The mission of the organization is to build a comprehensive workforce development system that supports individual prosperity and business competitiveness.

The organizational values essential to the growth and vitality of the system include:

- A skilled workforce that improves business and individual competitiveness, earning capacity, income and assets.
- Partnerships that support alignment, effectiveness and continuous improvement.
- High standards of accountability to the community.

In pursuit of its mission, Worksystems:

- Provides a single point of focus for regional workforce efforts.
- Builds linkages between regional government, business, labor, education and other leaders to enhance regional workforce programs and services.
- Invests in education, community-based and industry partners to provide skill development and related services.
- Supports projects to foster innovation, expand best practices and encourage system change.
- Coordinates workforce development activities with regional business, economic development and education strategies.
- Evaluates system quality and outcomes.

To ensure a responsive, demand driven workforce development system, WSI regularly engages targeted industry businesses to inform regional workforce services and investments. WSI has extensive experience in managing highly regulated Federal and state resources. Through this experience WSI has policies, processes and procedures in place to ensure that funds are spent on allowable and appropriate trainings. There are also advanced data systems and management protocols in place for monthly and quarterly monitoring of contract expenditures and program goals.

Serving as the fiscal and administrative agent for the workforce component of the NW Manufacturing Initiative, WSI awarded ARL funding to 26 Pacific NW defense contractors to support training for their existing workforce. Training was completed in a variety of areas including: Leadership and Supervisory Training, Lean Manufacturing, Project Management, and technical skills training related to advancements in technology and engineering. All of these trainings are focused on streamlining processes, and

increasing efficiency and effectiveness in either producing a more cost effective product or developing new products that support the defense industry. Several of these companies have expressed a need for additional training funds and new companies have requested training funds as well.

Appendices

Serving as the fiscal and administrative agent for the ARL funds that supported incumbent worker training for Pacific NW defense contractors, WSI awarded funds to defense contractors through a series of competitive solicitations. The criteria for the NWMI grants was created based on similar projects that WSI has managed in the past, and in consultation with Manufacturing 21. For each solicitation a Request for Proposals was advertised following standard protocols and proposals were received from a variety of defense contractors. For each solicitation evaluation committees, made up of executives from area manufacturing companies and WSI staff, reviewed and scored the proposals based on specific criteria. Grants were awarded to proposals that were cost effective and most likely to increase the ability of the Defense Logistics supply chain to manufacture quality products for the US Military.

WSI maximized the cost effectiveness of the funds for companies in the defense industry supply chain by encouraging consortia applications. WSI convened existing industry associations (Manufacturing 21 and Pacific NW Defense Coalition) and training vendors to notify them of fund availability and provide opportunities to network and develop consortia applications. Training vendors interested in applying for funds to train businesses were required to submit references and letters of support from companies that planned to participate in their training.

After grant awards were made, WSI contracted with training vendors, individual defense contractors and company consortia to provide training to incumbent workers at defense industry contractors. WSI established reporting guidelines and protocols to monitor that funds were used in an appropriate manner and met the intent of the NWMI. WSI worked with contractors to develop training plans and then monitored for satisfactory completion of training deliverables that were outlined in submitted proposals.

The following project summaries describe the training that was completed with each grant award. The summaries include:

- Amount of the grant award
- Number of workers trained
- Participating defense contractors
- Training completed and goals
- Results of training

Benchmade Knives**Grant: \$25,000**

Benchmade sent 6 of their management team to the Leadership Skills for Managers training at Portland State University and 12 team members to a management workshop on “Achieving Your Highest Priorities” by Franklin Covey Focus. 23 employees consisting of office and manufacturing staff attended a 2 day Lean training “Standard Work/Problem Solving”. Trainings enhanced management skills of their current management team. Lean training of their manufacturing staff helped them to exceed industry standards in a number of ways. They were not just able to gain efficiencies by getting better at what they do, but also to improve their product both in quality and cost by streamlining their manufacturing processes. Today they have a more effective and efficient product supply.

Clark College**Grant: \$50,000 Phase I**
Grant: \$35,608 Phase II

In Phase II, 40 individuals completed 120 hours of Onsite Lean and Six Sigma training with Clark College. Companies served included nLight Photonics, Carlisle Interconnect Technology, Saint Gobain Crystals, Solar World and ON Semiconductor. All 40 participants received Onsite Black Belt Training Certificates. This training enhanced the project’s sustainability by expanding the Six Sigma training to other employees not included in the initial training, ensuring that the company-sponsored Six Sigma Process Improvement projects are successfully completed and properly applied to each organization’s operation.

The additional benefit of Phase II is that Black Belts applied what they learned in Phase I by leading or participating in improvement projects prioritized by their organizations. For this investment the following estimated annual savings/benefits are provided according to the companies impacted:

1. Solutions implemented to decrease chiplet test failures (estimate annual savings \$115,000)
2. Reduced annual cost of scrap by \$17,300
3. Solutions implemented to extend pad life, reduce slurry usage and an undesirable residue remaining after a polishing operation resulting in an annual cost savings ranging from \$35,000 to \$70,000, depending on production volume
4. Reduced product failure rate at final inspection (annual cost savings of \$110,000)
5. Implemented corrective actions to fix major discrepancies among different testers (annual savings of \$100,000 from false rejects)
6. Reduced ILP rate for Semiconductor manufacturers by 50% or more in two key process areas (annual cost savings of \$3,600,000)
7. Determined causes in wavelength variation and reduced variation (annual savings between \$100,000 to \$150,000, depending on production volume)

Clackamas Community College**Grant: \$49,815**

26 individuals attended the Manufacturing Leadership Academy and received 648 hours of training. All 26 received Employment Skills Training Certificates. The grant paid for 20 students from six companies, including Camp Withycombe, NW Technologies, Mark's Metals, Benchmade Knives, OECO, Blount, and WW Metal Fab, to attend training. These grant funds made it possible for an additional six students to attend with their companies' paying for their books and supplies – the college did not charge additional tuition for these students. Leadership Academy students were trained on quality programs, Lean events and training processes. Participants would then implement a leadership project within their company. Results of projects included:

- Reduction in employee turnover due to poor supervision
- Quality programs project reduced defect rates by 20-50%
- Communication project allowed front-end identification of defective products from vendors

Tripod Data Systems, Inc**Grant: \$50,000**

TDS manufactures survey tripods and hand-held equipment. The hand-held is a durable (can be run over by a truck or submerged in water) mini-computer that includes such things as geo-positioning software. They customize their equipment to meet the customer's specifications which requires significant project management coordination to successfully execute.

TDS was able to train 60 employees. Employees were trained in Project Management Methodologies Mastery, Fundamentals of Product Management, Microsoft Project levels 1 and 2, and Practical Product Management. The books they are using, funded through the training, are the basis for their Dashboard status system which is now implemented across all departments from manufacturing to engineering, sales and marketing, to administration. They have now implemented a formal Project Management Office and realigned their processes. TDS integrated the PMO with their Quality Systems and are coordinating an effort to complete their ISO 9000 certification. They have designated their first formal Project Manager who will guide other projects within the organization to comply with the standards they adopted following the training guidelines.

The company reported that this training grant allowed them to not only select the best project management process for them but to implement it throughout their entire company to better meet the demands of their customers like the US Military.

Tripod Data Systems Testimonial

I would like to take this opportunity to give you a little update on changes we have made because of the grant we are receiving.

When we started to contemplate the training we might schedule with your grant funding we wanted to see if we could streamline our processes and provide better service to our customers, like the Dept. of Defense. As we evaluated the multitude of training opportunities the potential of what we could accomplish became clearer the groundwork began to build a comprehensive plan to improve. We contemplated training opportunities we could never have accomplished on our own. A couple of classes in Project Management became a focused training program starting with the Fundamentals of Project Management and will take us through multiple levels of tools and methodologies. Each step is helping us learn how to understand what our customers need and, how to better manage our projects. We are already seeing results occur.

Immediately after Microsoft Project training people began inputting their projects into the program, identifying gaps, and finding areas that could be tightened up. Our learning about more methodologies is teaching us there is more than one way to manage but we need to know how to select the one that works best for each project so we have a better understanding of the values of each.

We decided to create a single resource site on our SharePoint for all project managers to use with templates and examples of completed projects that are examples of accomplishments. This will help drive consistency and clarity. This lead to the recognition that we need a more formal framework across the organization for managing projects. It will allow us to take on more projects for our customers and better adapt to their needs. The plan for a formal framework is now actively being created. Ultimately we will be much more adept at identifying our resource needs, managing them to their maximum capability and achieving our objectives both effectively and efficiently. We are beginning to better track our human capital commitment and finding ways to maximize our commitments to our customers.

I don't know when, if or how we would have ever accomplished these changes in such a short time span had it not been through the opportunity this grant created for us. We have just begun to see the potential for what we can become and we are very excited.

Thank you so much, this grant should benefit all of us-the DOD, our employees, our systems, and our company both now and in the future.

Nancy Hawkins
Human Resource Manager
345 SW Avery Ave.
Corvallis, OR 97333
541.750.9331 Phone

Miles Fiberglass**Grant: \$26,700**

Miles Fiberglass manufactures Hum V reinforcement kits for hoods and fuel tanks. They partnered with Plastifab, manufacturer of landing platforms for UAV's, and Simplex, manufacturer of helicopter parts, to offer their employees training opportunities. 39 Miles Fiberglass employees, 20 from Plastifab, and 4 from Simplex received Certified Composite Instructor Training. The Certified Composites Technician Course is a nationally recognized course developed by the American Composites Manufacturers Association in order to educate and enhance quality to the composite industry. By further educating employees in the composite industry about technical information, this training helped companies to increase production and produce higher quality military products.

SAM Medical Products**Grant: \$50,000**

SAM is a small Oregon-based medical device manufacturer with 33 employees. They supply the US military with medical devices that range from splints and slings to a unique dressing for the prevention and treatment of pressure sores in the residual limbs of amputees. As they manufacture most and package all of their devices locally they identified a need for lean manufacturing and total productive maintenance trainings to streamline their processes. SAM Medical trained 31 plant and sales staff at all levels in a variety of areas. The overall focus of the training was to improve processes and better meet regulatory standards. Training areas included Total Productive Maintenance, First Aide and Safety, Lean Training, Inventory Management, Purchasing Supply Chain, ISO 13485, Management/Leadership, Executive Management, and Strategy.

SORED I**Grant: \$28,600**

SORED I represents a consortium of 2 Josephine County based companies ICx/Mesosystems and Radio Design Group. ICx/Mesosystems designs cutting-edge detection and security solutions for the Defense industry and others. Radio Design Group, Inc. provides advanced research, design, development, prototyping, and production of various RF and other electronic devices. Much of the design work may be categorized as advanced concepts that are engineered into practical applications through rigorous design and prototyping. Both companies have advanced technical training needs for their skilled staff of engineers and developers.

ICx Technologies trained 2 employees. One was trained in Electrospray Reactor Assembly operation and the other in Advanced Part Modeling. Radio Design trained 11 employees. Employees received training in Advanced Sheet Metal, Advanced Assembly, Advanced Modeling, On-Line LabVIEW Intermediate, Embedded Designs, Designing for Performance, Essentials of FPGA Design, RF and Microwave Receiver Design, PCB Design Principles, System Administration, PCB Techniques/Materials, CID Certification and Electronic Tech Certification, and Digital Signal Processing

Advanced design courses enabled companies to plan for maximum reliability and functional usability (matters that certainly affect logistics). The System Administration training is directly related to logistics as it is an advanced logistics management program

designed to enable more efficient operations through the use of automation tools and a disciplined approach to logistics. Successful implementation of electrospray reactor techniques will result in more accurate and reliable threat-aerosol sensors for homeland security and national defense.

Oregon Institute of Technology

Grant: \$50,000

OIT is Oregon's premiere university for hands-on education in the engineering environment and received grant funds to deliver a series of seven courses from their Product Design Center to enhance the effectiveness of technical employees in companies that are defense contractors or suppliers/service providers to defense contractors. The courses are targeted to engineering technicians and engineers and are based on existing curricula but in a condensed format. OIT provided training in Project Management for Manufacturers, GD&T Basics, CATIA Product Design Software, Solid Works, Visual Basics for CATIA Users, and Business and Technical Writing for Engineers. Sixty-nine individuals participated from the following companies: Boeing, PCC Structural, Warn, OECO, Cascade Engineering Technologies, and Oregon Iron Works.

These trainings have increased the participating companies' ability to serve the US Defense logistics supply chain in the following ways:

- Increased ability to utilize full power and complexity of software and help others at work
- Minimize down time
- Improved chances for competitive contracts
- Improved training time frames and increase productivity
- Better communicate concepts and ideas to customers
- Better able to utilize resources and plan projects
- Learned new capabilities of Project Management software
- Provide more standard formats for CATIA programming

In addition to training, these funds were used to research industry's specific needs for Non-Destructive Testing training, identify subject matter experts and develop a plan to develop the capacity within OIT to deliver training in this subject area in the future. This research culminated in a report on the need, availability and capacity for non-destructive testing to be taught in the region.

Washington Manufacturing Services

Grant: \$6995

Aluminum Chambered Boats (ACB) is a defense contractor that provides boats to the Navy, Marines, Army and Coast Guard. Washington Manufacturing Services provided "Principles for Implementing Lean Enterprise-Concept to Drawing Release for Fabrication" 5 day Kaizen event to 8 employees of ACB. The event helped create efficient internal engineering and manufacturing fabrication processes, enhanced communications, established procedures, and improved tracking of costs and free cash flow.

Conclusion

The Army Research Laboratory funds that supported the NW Manufacturing Initiative provided a much needed resource to defense contractors in the Pacific Northwest. With State and Federal resources for incumbent worker training dwindling from year to year, many companies are unable to enhance the skills of their workforce to maintain competitiveness in a global economy. In the last year of the project this was one of the only funding sources that supported incumbent worker training in the State of Oregon. Companies, especially smaller ones, frequently do not have the resources to invest in training for their workers that can foster innovation and increase competitiveness. ARL funds for this project helped to bolster the skills of the workforce of defense contractors in the region which ultimately results in more high quality, innovative and cost effective products manufactured for the US Military.