

Slides

NPS Student Thesis Presentations

Report Documentation Page

Form Approved
OMB No. 0704-0188

Public reporting burden for the collection of information is estimated to average 1 hour per response, including the time for reviewing instructions, searching existing data sources, gathering and maintaining the data needed, and completing and reviewing the collection of information. Send comments regarding this burden estimate or any other aspect of this collection of information, including suggestions for reducing this burden, to Washington Headquarters Services, Directorate for Information Operations and Reports, 1215 Jefferson Davis Highway, Suite 1204, Arlington VA 22202-4302. Respondents should be aware that notwithstanding any other provision of law, no person shall be subject to a penalty for failing to comply with a collection of information if it does not display a currently valid OMB control number.

1. REPORT DATE SEP 2011	2. REPORT TYPE	3. DATES COVERED 00-00-2011 to 00-00-2011			
4. TITLE AND SUBTITLE Second Annual Systems Engineering Lessons Learned Conference Held Sept 20-21 2011, Seaside, CA		5a. CONTRACT NUMBER			
		5b. GRANT NUMBER			
		5c. PROGRAM ELEMENT NUMBER			
6. AUTHOR(S)		5d. PROJECT NUMBER			
		5e. TASK NUMBER			
		5f. WORK UNIT NUMBER			
7. PERFORMING ORGANIZATION NAME(S) AND ADDRESS(ES) Naval Postgraduate School, Monterey, CA, 93943		8. PERFORMING ORGANIZATION REPORT NUMBER			
9. SPONSORING/MONITORING AGENCY NAME(S) AND ADDRESS(ES)		10. SPONSOR/MONITOR'S ACRONYM(S)			
		11. SPONSOR/MONITOR'S REPORT NUMBER(S)			
12. DISTRIBUTION/AVAILABILITY STATEMENT Approved for public release; distribution unlimited					
13. SUPPLEMENTARY NOTES					
14. ABSTRACT					
15. SUBJECT TERMS					
16. SECURITY CLASSIFICATION OF:			17. LIMITATION OF ABSTRACT Same as Report (SAR)	18. NUMBER OF PAGES 148	19a. NAME OF RESPONSIBLE PERSON
a. REPORT unclassified	b. ABSTRACT unclassified	c. THIS PAGE unclassified			



Improving Health Care Delivery for Posttraumatic Stress Disorder

An Interrelated Approach Leveraging
Systems Engineering and
Optimization

Principals

- Author
 - Scott McKenzie
- Thesis Advisors
 - Douglas MacKinnon, PhD
 - John Osmundson, PhD
- Sponsors
 - Josef Ruzek, PhD (National Center for PTSD)
 - Steven Lindley, MD (Director, OMH, VA Palo Alto)

Background

- OEF/OIF Veterans with PTSD
 - Up to 28% would screen for PTSD
 - Palo Alto VAHCS = 80 new cases per month
- Limited Resources
- Variety of Treatment Options
 - Care Management
 - Prolonged Exposure (PE)
 - Cognitive Processing Therapy (CPT)
 - Medication Management

Research Questions

- For the system of PTSD Health Care Delivery, what are optimal factors that will maximize efficiency, capacity, and quality?
- For PTSD Health Care Delivery:
 - What defines efficiency?
 - What defines capacity?
 - What defines quality?

Systems Engineering Approach

1. Define the Problem
2. Identify and Analyze Mission and Environments
3. Identify and Decompose Functional Requirements
4. Quantify Processes
5. Define System Attributes and Measures
6. Construct ExtendSim Model
7. Verify ExtendSim Model
8. Design of Experiments (DOE)
9. Run Simulation Experiment
10. Fit JMP Model to Simulation Results
11. Optimization
12. Analysis of Results

Scope of Research

- To examine a generalized system of PTSD Health Care Delivery.
 - Provides a Model for the System
 - Broad Set of Assumptions
 - Requires Fine-Tuning
 - Requires Validation

Benefits of this Study

- *Understand* the System
 - Discover a Set of Factors
 - Manipulate Factors and Discover Responses
- Improve Data Collection

Increase the “Speed of Improvement”

System Analysis

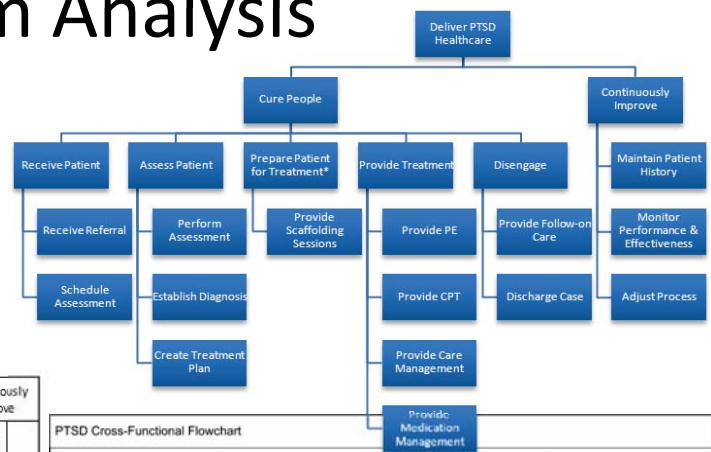
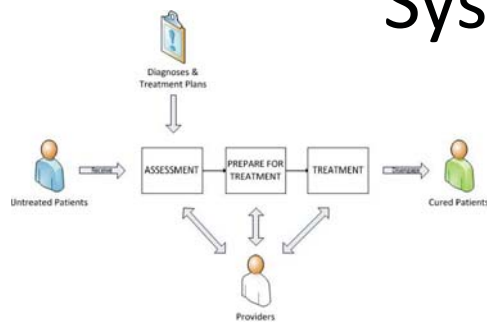

	Receive	Assess	Prepare	Treat	Disengage	Continuously Improve
	Receive Referral Schedule Assessment	Perform Assessment Establish Diagnosis	Create Treatment Plan Provide Scaffolding	Provide PE Provide CPT Provide Care Management Provide Medication Management	Provide Follow-on Care Discharge Case	Maintain Patient History Measure Performance & Effectiveness Adjust Process
Telephone Reception	X					
Reception Desk	X	X				
Medical Info System	X	X	X	X		X
Human Provider/Staff	X	X	X	X	X	X
PTSD Website			X		X	X
PTSD Policy						X

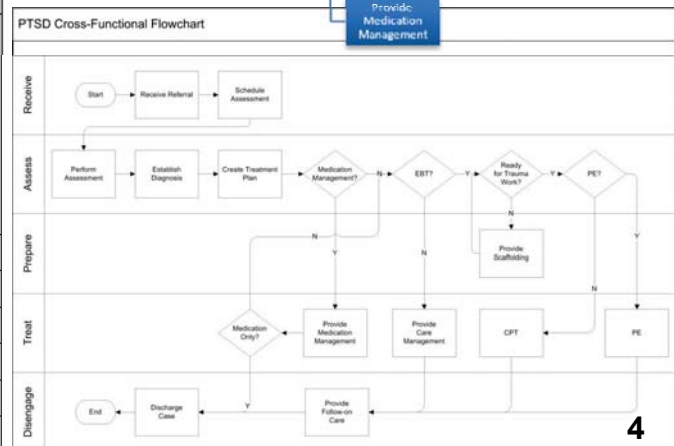

ExtendSim Modeling

- Providers
 - Schedule, Quantity, Utilization
- Patients
 - Rate of Arrival, Rate of Drop
- Assessments
- Diagnoses
- Structure of Treatment Plans
 - PE, CPT, Care Management, Medication Management
- Treatment Plan Distributions
- Provider Intensity
- Patient-Provider Encounters
 - Patient Cancellations, Encounter Failures

ExtendSim Model

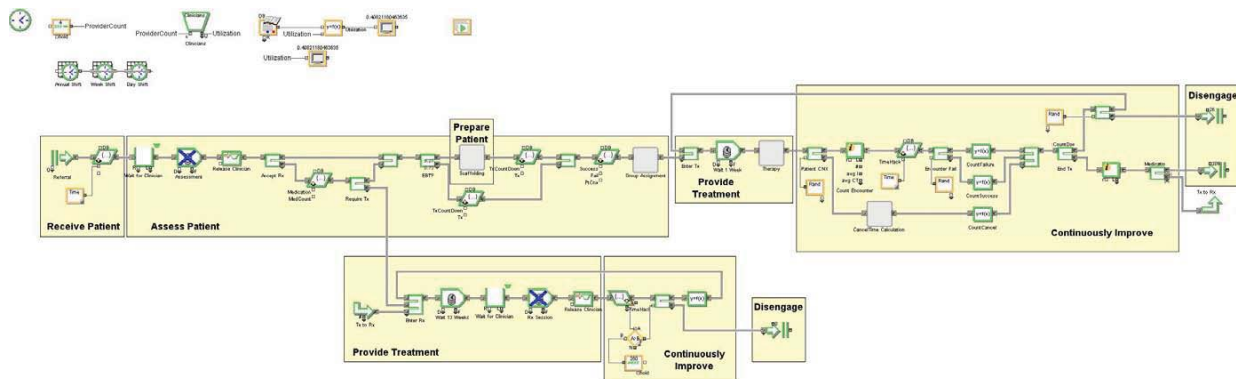

Simulates 5 years of clinic operations.

Design of Experiments

#	Factor	Level 1	Level 2	Level 3
1	Provider Count	2	3	4
2	Provider Intensity	75% - 2 25% - 1	50% - 2 50% - 1	25% - 2 75% - 1
3	CPT Group Size	1	5	9
4	CM Group Size	1	5	9
5	Scaffolding Session Count	3	6	9
6	Cancellation Rate	18%	9%	--
7	Failure Rate	30%	20%	10%
8	Drop Rate	2%	1%	--

*Note that a full-factorial experiment design includes $(3^6)(2^2) = 2916$ scenarios.
With three trials per scenario, there are 8748 separate trials.
Without Scenario Manager of ExtendSim 8, would have required optimized array.*

Design of Experiments

Attribute	Measured Response	Definition
Efficient	Provider Utilization	% of available provider time engaged in PTSD work
Capacity	Throughput	Quantity of patients completed over time
Timely	Treatment Duration	Average duration of traditional treatment plan
Timely	Time Between Encounters	Average time between traditional therapy encounters

Fit Model in JMP

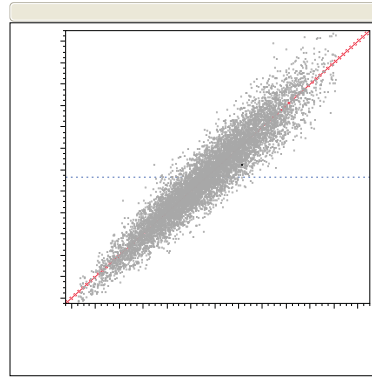
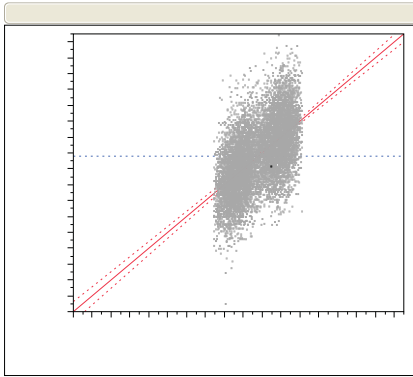
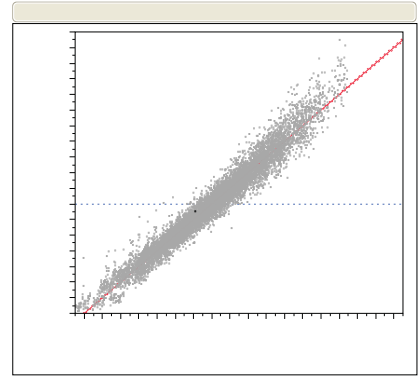
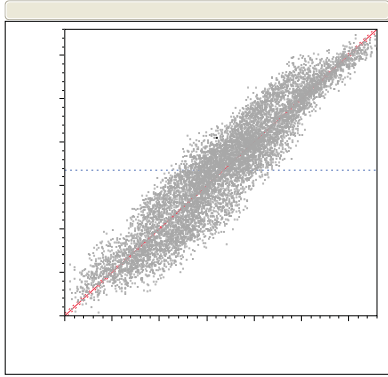

Prediction Profiler

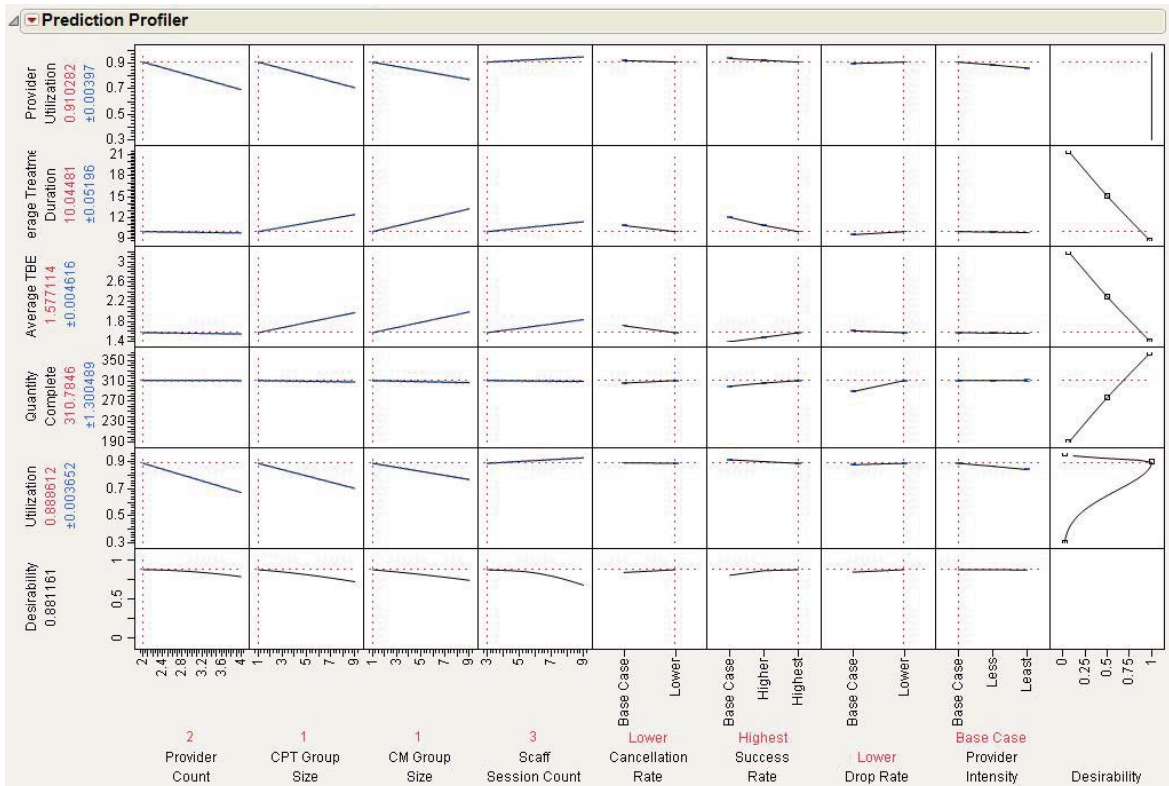

Optimization

Attribute	Measured Response	Desire
Efficient	Provider Utilization	Set to 90%
Capacity	Throughput	Maximize
Timely	Treatment Duration	Minimize
Timely	Time Between Encounters	Minimize

Results

#	Factor	Level 1	Level 2	Level 3
1	Provider Count	2	3	4
2	Provider Intensity	75% - 2 25% - 1	50% - 2 50% - 1	25% - 2 75% - 1
3	CPT Group Size	1	5	9
4	CM Group Size	1	5	9
5	Scaffolding Session Count	3	6	9
6	Cancellation Rate	18%	9%	--
7	Failure Rate	30%	20%	10%
8	Drop Rate	2%	1%	--

Conclusions

Attribute	Measured Response	Base	Opt	Delta	% Delta
Efficient	Provider Utilization	0.61	0.88	0.27	44%
Capacity	Throughput	270	310	40	15%
Timely	Treatment Duration	17.6	10.0	-7.6	-43%
Timely	Time Between Encounters	2.30	1.58	-0.72	-31%
Overall System Desirability		0.49	0.88	0.39	80%

Future Work

- Validate Model
- Improve Measurement of *Quality*
 - *Incorporate Treatment Efficacy*
- Improve HR Modeling
 - *Incorporate Provider Qualification*
 - *Incorporate Staff Resources*
- Improve Alignment with Reality
 - *Conduct a more detailed analysis of historical data*
 - *Incorporate a bogus referral rate*
 - *Improve accuracy of medication management simulation*
 - *Investigate patient drop, cancellation, and encounter failure rates.*
- Improve VA Data Tracking and Presentation

Questions

Scott McKenzie

Research Associate/PhD Student

Distributed Information Systems Experimentation (DISE)

Naval Postgraduate School

1411 Cunningham Road

Code IS/06

Monterey, CA 93943

(831)917-0515 *cell*

(831)656-2931 *office*

samckenz@nps.edu





**Development and Application
of a Multi-Attribute Decision Making Process
to Optimize Renewable Energy Systems
for Afghanistan National Security Forces**

Capt Derek Law & Capt Scott Tyley

21 Sep 2011

**Thesis Advisor: Dr. Thomas Huynh
Thesis Co-Advisor: Dr. Tommer Ender**



Agenda

- **Problem**
- **Research Question**
- **Approach**
- **Results**
- **Benefits**
- **Questions & Answers**



Problems with Fossil Fuel Energy Systems

- **Security risk**

- **Lives**

- “...one casualty for every 24 fuel resupply convoys in Afghanistan.” (Eady et al., 2009)

- **Corruption**

- Congressional investigation found fuel transport/supply system corrupt

- **Dependence**

- Reliance on other countries a risk to national security

- **Logistics challenges**

- **Terrain**

- **Fuel infrastructure**



Problems with Fossil Fuel Energy Systems

- **Cost**

- **Fully Burdened Cost of Fuel**

- \$4.18 - \$400 per gallon for Afghanistan

- **National security concern**

- Reprioritizes other defense projects and causes economic burden
 - Bases in Afghanistan can require 5,400 gallons of fuel per day equaling almost \$5 million annually (Kuntz, 2007)



(Catepillar, 2010)

- **Environmental impact**

- **Exhaust causes acute and chronic illness to include cancer risks (Kojima, 2001)**

- **In direct conflict with Afghanistan’s national development strategy (ANDS, 2008)**



Research Question

- **Problem**

- U.S. implementation of diesel only power sources in Afghanistan
- Lacking decision making process to support determination of optimal energy solutions to include energy sources other than diesel types for Afghanistan National Security Force installations

- **Research question**

- What approach can be developed to aid in determining better energy systems for Afghanistan National Security Force installations?



Approach

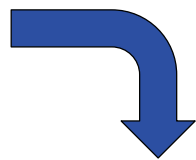
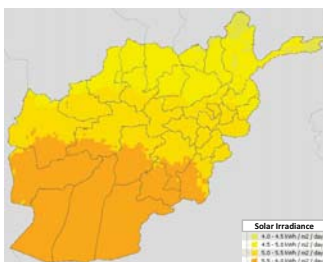

Law-Tyley Approach

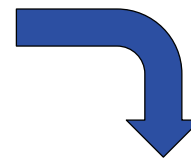

- **Environmental characteristics**
- **Multiple attribute decision making**
- **Optimal combinations of energy sources**

Civil Engineering Rubric

FRC = 54.82/ther	Poor		Marginal		Fair		Good		Excellent		Outstanding		Scale
	1	2	3	4	5	6	7	8	9	10	11	12	Wind Class
Load Profile: kVA/00	0-200	200-300	300-400	400-500	500-600	600-700	700-800	800-900	900-1000	1000-1100	1100-1200	>1200	m/sec
4.0-4.5	14.00	15.75	17.50	19.25	21.00	22.75	24.50	26.25	28.00	29.75	31.50	33.25	35.00
4.5-5.0	15.00	16.88	18.75	20.63	22.50	24.38	26.25	28.13	30.00	31.88	33.75	35.63	37.50
5.0-5.5	16.00	18.00	20.00	22.00	24.00	26.00	28.00	30.00	32.00	34.00	36.00	38.00	40.00
5.5-6.0	17.00	19.25	21.50	23.75	26.00	28.25	30.50	32.75	35.00	37.25	39.50	41.75	44.00
6.0-6.5	18.00	20.50	23.00	25.50	28.00	30.50	33.00	35.50	38.00	40.50	43.00	45.50	48.00
6.5-7.0	19.00	21.75	24.25	26.75	29.25	31.75	34.25	36.75	39.25	41.75	44.25	46.75	49.25
7.0-7.5	20.00	23.13	25.63	28.13	30.63	33.13	35.63	38.13	40.63	43.13	45.63	48.13	50.63
7.5-8.0	21.00	24.63	27.13	29.63	32.13	34.63	37.13	39.63	42.13	44.63	47.13	49.63	52.13
8.0-8.5	22.00	26.13	28.63	31.13	33.63	36.13	38.63	41.13	43.63	46.13	48.63	51.13	53.63
8.5-9.0	23.00	27.63	30.13	32.63	35.13	37.63	40.13	42.63	45.13	47.63	50.13	52.63	55.13
9.0-9.5	24.00	29.13	31.63	34.13	36.63	39.13	41.63	44.13	46.63	49.13	51.63	54.13	56.63
9.5-10.0	25.00	30.63	33.13	35.63	38.13	40.63	43.13	45.63	48.13	50.63	53.13	55.63	58.13
10.0-10.5	26.00	32.13	34.63	37.13	39.63	42.13	44.63	47.13	49.63	52.13	54.63	57.13	59.63
10.5-11.0	27.00	33.63	36.13	38.63	41.13	43.63	46.13	48.63	51.13	53.63	56.13	58.63	61.13
11.0-11.5	28.00	35.13	37.63	40.13	42.63	45.13	47.63	50.13	52.63	55.13	57.63	60.13	62.63
11.5-12.0	29.00	36.63	39.13	41.63	44.13	46.63	49.13	51.63	54.13	56.63	59.13	61.63	64.13
12.0-12.5	30.00	38.13	40.63	43.13	45.63	48.13	50.63	53.13	55.63	58.13	60.63	63.13	65.63
12.5-13.0	31.00	39.63	42.13	44.63	47.13	49.63	52.13	54.63	57.13	59.63	62.13	64.63	67.13
13.0-13.5	32.00	41.13	43.63	46.13	48.63	51.13	53.63	56.13	58.63	61.13	63.63	66.13	68.63
13.5-14.0	33.00	42.63	45.13	47.63	50.13	52.63	55.13	57.63	60.13	62.63	65.13	67.63	70.13
14.0-14.5	34.00	44.13	46.63	49.13	51.63	54.13	56.63	59.13	61.63	64.13	66.63	69.13	71.63
14.5-15.0	35.00	45.63	48.13	50.63	53.13	55.63	58.13	60.63	63.13	65.63	68.13	70.63	73.13
15.0-15.5	36.00	47.13	49.63	52.13	54.63	57.13	59.63	62.13	64.63	67.13	69.63	72.13	74.63
15.5-16.0	37.00	48.63	51.13	53.63	56.13	58.63	61.13	63.63	66.13	68.63	71.13	73.63	76.13
16.0-16.5	38.00	50.13	52.63	55.13	57.63	60.13	62.63	65.13	67.63	70.13	72.63	75.13	77.63
16.5-17.0	39.00	51.63	54.13	56.63	59.13	61.63	64.13	66.63	69.13	71.63	74.13	76.63	79.13
17.0-17.5	40.00	53.13	55.63	58.13	60.63	63.13	65.63	68.13	70.63	73.13	75.63	78.13	80.63
17.5-18.0	41.00	54.63	57.13	59.63	62.13	64.63	67.13	69.63	72.13	74.63	77.13	79.63	82.13
18.0-18.5	42.00	56.13	58.63	61.13	63.63	66.13	68.63	71.13	73.63	76.13	78.63	81.13	83.63
18.5-19.0	43.00	57.63	60.13	62.63	65.13	67.63	70.13	72.63	75.13	77.63	80.13	82.63	85.13
19.0-19.5	44.00	59.13	61.63	64.13	66.63	69.13	71.63	74.13	76.63	79.13	81.63	84.13	86.63
19.5-20.0	45.00	60.63	63.13	65.63	68.13	70.63	73.13	75.63	78.13	80.63	83.13	85.63	88.13
20.0-20.5	46.00	62.13	64.63	67.13	69.63	72.13	74.63	77.13	79.63	82.13	84.63	87.13	89.63
20.5-21.0	47.00	63.63	66.13	68.63	71.13	73.63	76.13	78.63	81.13	83.63	86.13	88.63	91.13
21.0-21.5	48.00	65.13	67.63	70.13	72.63	75.13	77.63	80.13	82.63	85.13	87.63	90.13	92.63
21.5-22.0	49.00	66.63	69.13	71.63	74.13	76.63	79.13	81.63	84.13	86.63	89.13	91.63	94.13
22.0-22.5	50.00	68.13	70.63	73.13	75.63	78.13	80.63	83.13	85.63	88.13	90.63	93.13	95.63
22.5-23.0	51.00	69.63	72.13	74.63	77.13	79.63	82.13	84.63	87.13	89.63	92.13	94.63	97.13
23.0-23.5	52.00	71.13	73.63	76.13	78.63	81.13	83.63	86.13	88.63	91.13	93.63	96.13	98.63
23.5-24.0	53.00	72.63	75.13	77.63	80.13	82.63	85.13	87.63	90.13	92.63	95.13	97.63	100.13
24.0-24.5	54.00	74.13	76.63	79.13	81.63	84.13	86.63	89.13	91.63	94.13	96.63	99.13	101.63
24.5-25.0	55.00	75.63	78.13	80.63	83.13	85.63	88.13	90.63	93.13	95.63	98.13	100.63	103.13
25.0-25.5	56.00	77.13	79.63	82.13	84.63	87.13	89.63	92.13	94.63	97.13	99.63	102.13	104.63
25.5-26.0	57.00	78.63	81.13	83.63	86.13	88.63	91.13	93.63	96.13	98.63	101.13	103.63	106.13
26.0-26.5	58.00	80.13	82.63	85.13	87.63	90.13	92.63	95.13	97.63	100.13	102.63	105.13	107.63
26.5-27.0	59.00	81.63	84.13	86.63	89.13	91.63	94.13	96.63	99.13	101.63	104.13	106.63	109.13
27.0-27.5	60.00	83.13	85.63	88.13	90.63	93.13	95.63	98.13	100.63	103.13	105.63	108.13	110.63
27.5-28.0	61.00	84.63	87.13	89.63	92.13	94.63	97.13	99.63	102.13	104.63	107.13	109.63	112.13
28.0-28.5	62.00	86.13	88.63	91.13	93.63	96.13	98.63	101.13	103.63	106.13	108.63	111.13	113.63
28.5-29.0	63.00	87.63	90.13	92.63	95.13	97.63	100.13	102.63	105.13	107.63	110.13	112.63	115.13
29.0-29.5	64.00	89.13	91.63	94.13	96.63	99.13	101.63	104.13	106.63	109.13	111.63	114.13	116.63
29.5-30.0	65.00	90.63	93.13	95.63	98.13	100.63	103.13	105.63	108.13	110.63	113.13	115.63	118.13
30.0-30.5	66.00	92.13	94.63	97.13	99.63	102.13	104.63	107.13	109.63	112.13	114.63	117.13	119.63
30.5-31.0	67.00	93.63	96.13	98.63	101.13	103.63	106.13	108.63	111.13	113.63	116.13	118.63	121.13
31.0-31.5	68.00	95.13	97.63	100.13	102.63	105.13	107.63	110.13	112.63	115.13	117.63	120.13	122.63
31.5-32.0	69.00	96.63	99.13	101.63	104.13	106.63	109.13	111.63	114.13	116.63	119.13	121.63	124.13
32.0-32.5	70.00	98.13	100.63	103.13	105.63	108.13	110.63	113.13	115.63	118.13	120.63	123.13	125.63
32.5-33.0	71.00	99.63	102.13	104.63	107.13	109.63	112.13	114.63	117.13	119.63	122.13	124.63	127.13
33.0-33.5	72.00	101.13	103.63	106.13	108.63	111.13	113.63	116.13	118.63	121.13	123.63	126.13	128.63
33.5-34.0	73.00	102.63	105.13	107.63	110.13	112.63	115.13	117.63	120.13	122.63	125.13	127.63	130.13
34.0-34.5	74.00	104.13	106.63	109.13	111.63	114.13	116.63	119.13	121.63	124.13	126.63	129.13	131.63
34.5-35.0	75.00	105.63	108.13	110.63	113.13	115.63	118.13	120.63	123.13	125.63	128.13	130.63	133.13
35.0-35.5	76.00	107.13	109.63	112.13	114.63	117.13	119.63	122.13	124.63	127.13	129.63	132.13	134.63
35.5-36.0	77.00	108.63	111.13	113.63	116.13	118.63	121.13	123.63	126.13	128.63	131.13	133.63	136.13
36.0-36.5	78.00	110.13	112.63	115.13	117.63	120.13	122.63	125.13	127.63	130.13	132.63	135.13	137.63
36.5-37.0	79.00	111.63	114.13	116.63	119.13	121.63	124.13	126.63	129.13	131.63	134.13	136.63	



Approach

- Based on Ender's Multi-Attribute Decision Making (MADM) process for renewable energy sources (Ender et al., 2010)
- Modifications of Ender's MADM process
 - Prioritization of stakeholder requirements through analytical hierarchy process (AHP)
 - Inclusion of initial and lifecycle costs in requirements development
 - Utilization of actual solar and wind data
 - Inclusion of specific hardware characteristics
 - Definition of hourly load profile
 - Optimization using simple additive weighting (SAW) technique
 - Generation of engineering rubric of optimized systems

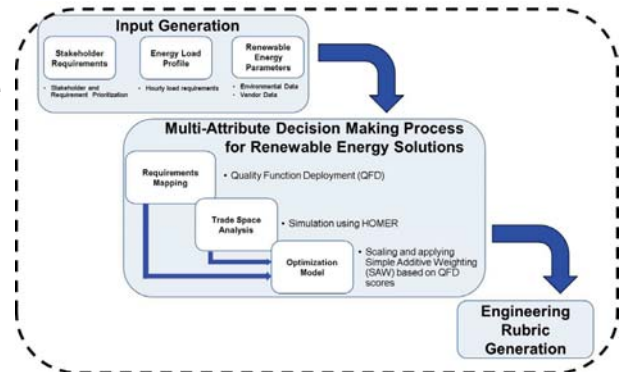

Approach

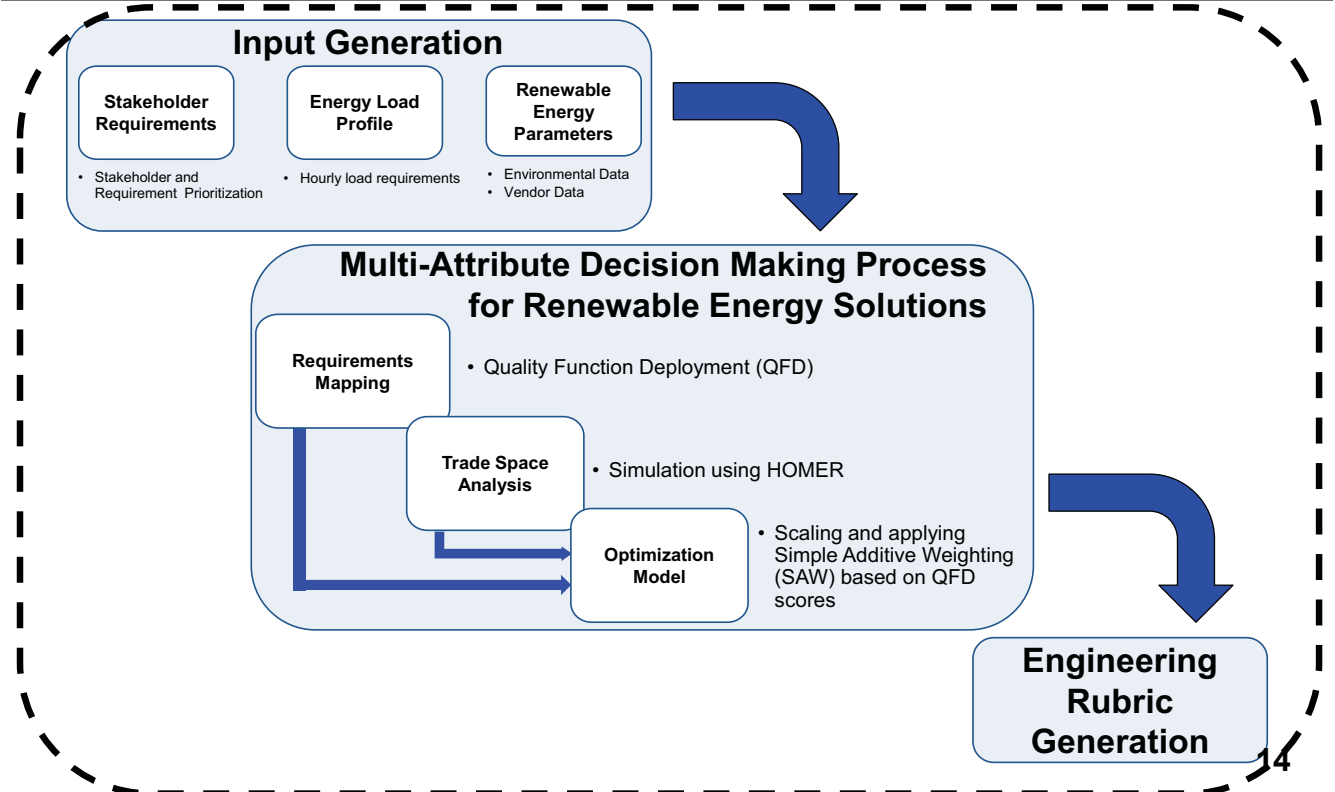



Approach

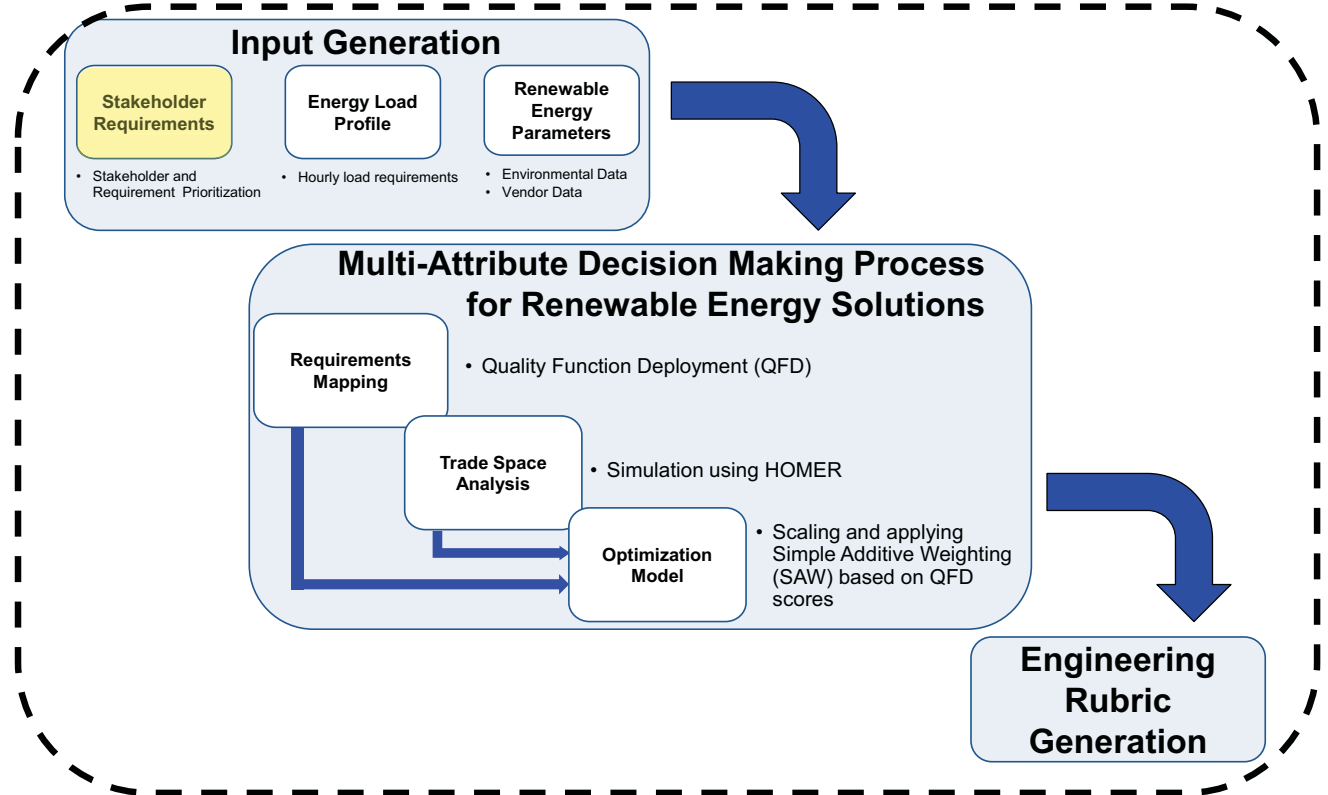

Stakeholder Requirements

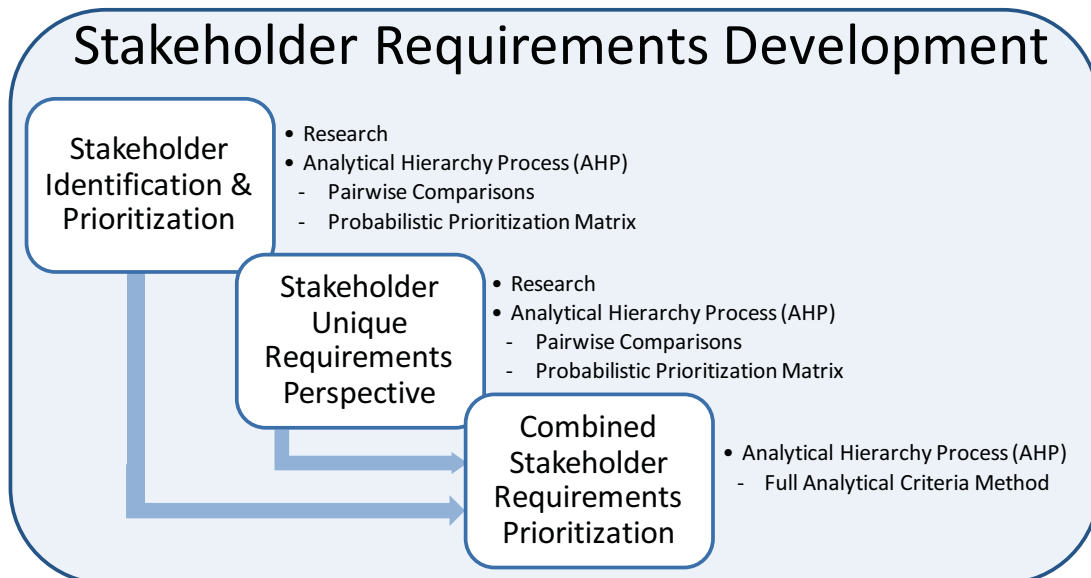



Stakeholder Requirements

Stakeholder Requirements Development

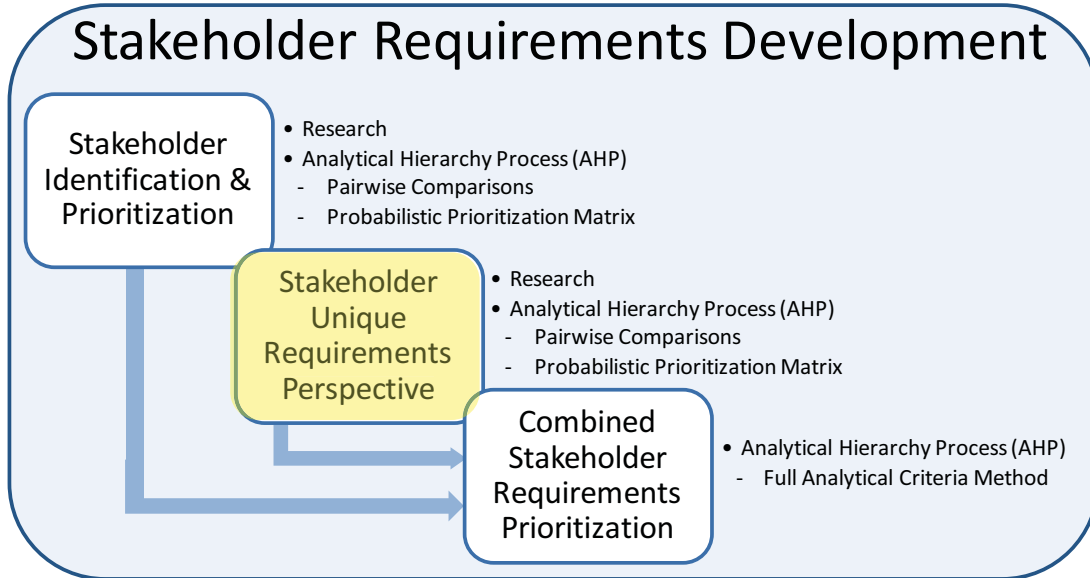

Stakeholder Unique Requirements Perspective

USACE																		
Top Level System Requirements																		Top Level System Requirements
Security	9	8	7	6	5	4	3	2	1	2	3	4	5	6	7	8	9	Environmental Impact
Security	9	8	7	6	5	4	3	2	1	2	3	4	5	6	7	8	9	Initial Capital Cost
Security	9	8	7	6	5	4	3	2	1	2	3	4	5	6	7	8	9	Life Cycle Cost
Environmental Impact	9	8	7	6	5	4	3	2	1	2	3	4	5	6	7	8	9	Initial Capital Cost
Environmental Impact	9	8	7	6	5	4	3	2	1	2	3	4	5	6	7	8	9	Life Cycle Cost
Initial Capital Cost	9	8	7	6	5	4	3	2	1	2	3	4	5	6	7	8	9	Life Cycle Cost

U.S. Army Corps of Engineers						
Concerns	Security	Environmental Impact (Attribute: Renewable Energy)	Initial Cost	Life Cycle Cost	n^{th} root	Weights
Security (Attributes: Logistics & Sustainment Overhead – fuel convoys, maintenance convoys, spares, energy)	1	7	0.20	0.50	0.91	0.15
Environmental Impact (Attribute: Renewable Energy)	0.14	1	0.14	0.25	0.27	0.04
Initial Cost	5	7	1	7	3.96	0.64
Life Cycle Cost	2	4	0.14	1	1.03	0.17

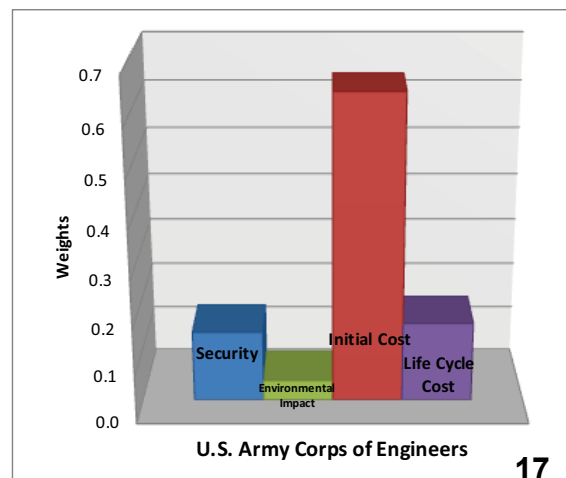



Stakeholder Requirements

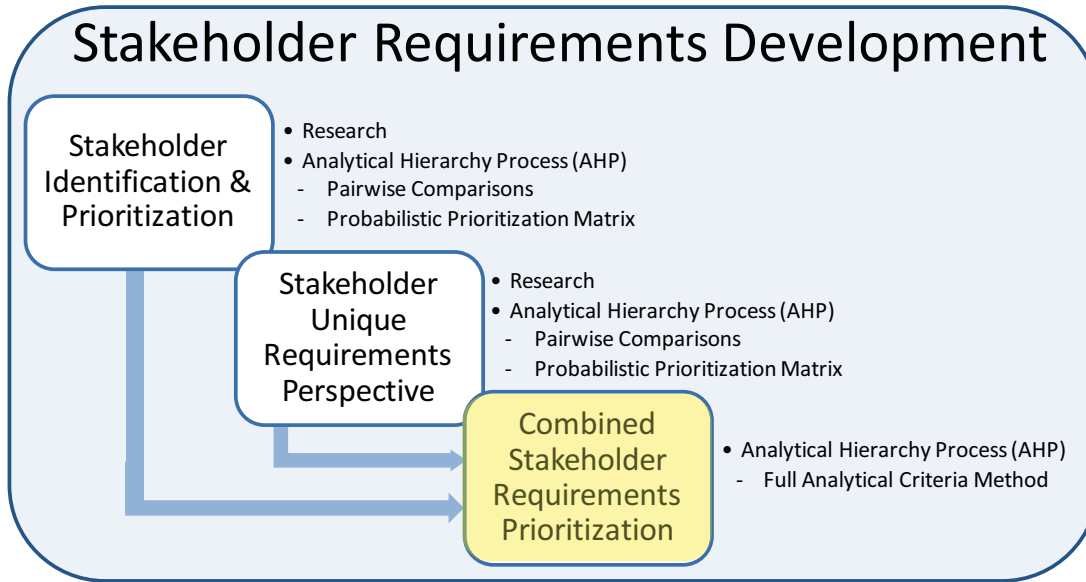

Combined Stakeholder Requirements Prioritization

Stakeholders	Stakeholder	1	2	3	4	n th root	Weights
	U.S. Army Corps of Engineers	1					
	U.S. Public		1				
	Afghanistan Government			1			
	International Security Assistance Force				1		
	U.S. Army Corps of Engineers	1	0.17	0.33	0.33	0.37	0.08
	U.S. Public	2	6	1	0.50	1.32	0.29
	Afghanistan Government	3	3	1	1	1.32	0.29
	International Security Assistance Force	4	3	2	1	1.57	0.34

Full analytical criteria method

Stakeholders	Security		Enviro		Cost		
	Security	Environment	Initial Cost	Life Cycle Cost			
	\$/kWh	%	\$	\$			
U.S. Army Corps of Engineers	0.081	0.012	0.003	0.052	0.014		
U.S. Public	0.288	0.177	0.014	0.049	0.049		
Afghanistan Government	0.286	0.188	0.019	0.042	0.039		
International Security Assistance Force	0.343	0.232	0.014	0.048	0.048		
Check Sum	1.00						
Weighted Performance	0.609	0.051	0.191	0.149		1.0	

U.S. Army Corps of Engineers	Concerns	1	2	3	4	n th root	Weights
	Security	1					
	Environmental Impact (Attribute: Renewable Energy)		1				
	Initial Cost			1			
	Life Cycle Cost				1		
	Security	1	7	0.20	0.50	0.91	0.15
	Environmental Impact (Attribute: Renewable Energy)	2	0.14	1	0.14	0.27	0.04
	Initial Cost	3	5	7	7	3.96	0.64
	Life Cycle Cost	4	2	4	0.14	1.03	0.17





Approach

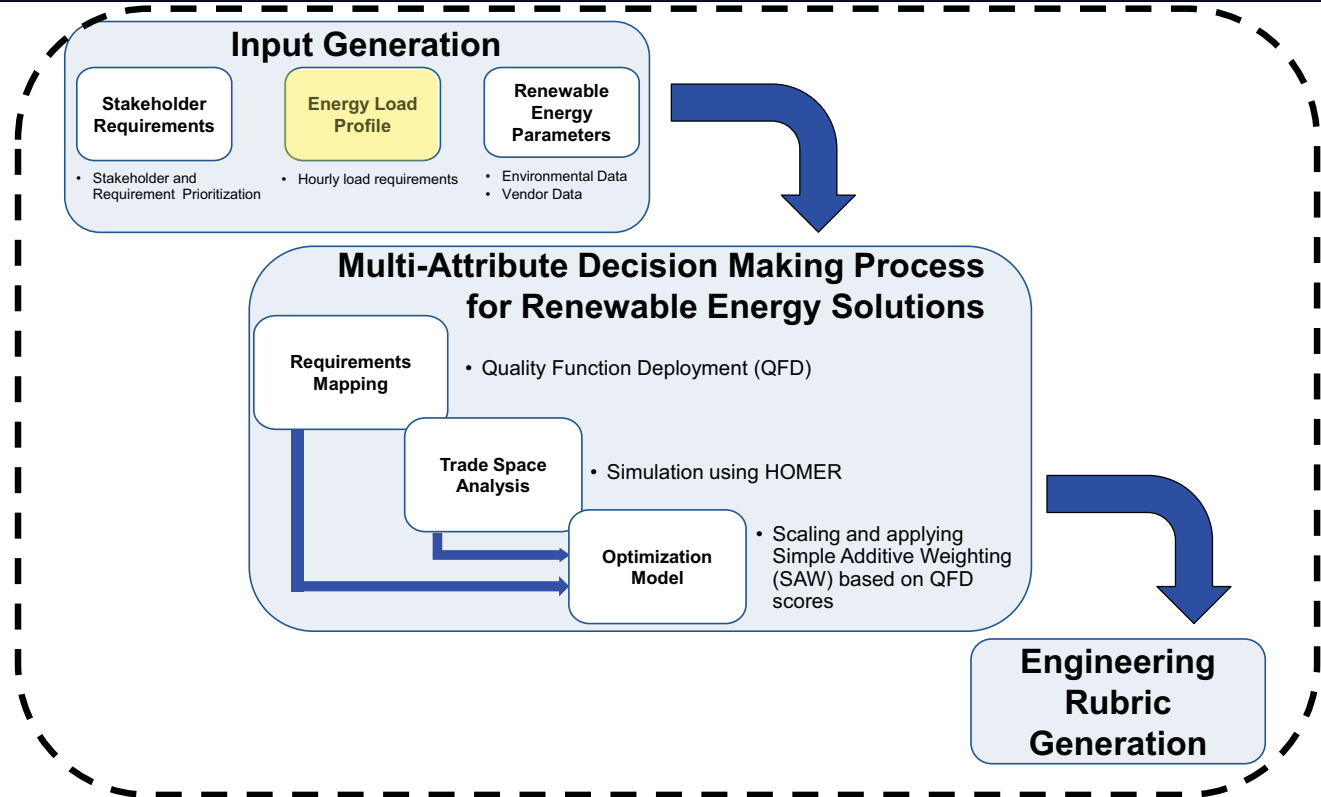

Energy Load Profile

- Marine Corps Experimental Forward Operating Base (ExFOB)
- USACE 60% heuristic for typical demand of connected load
 - Peak load -- 19.3 kW
 - Average instantaneous load -- 11.6 kW
 - Average daily load -- 278 kWh
- Average U.S. residential home \approx 30 kWh per day
- 278 kWh \approx 9 U.S. homes

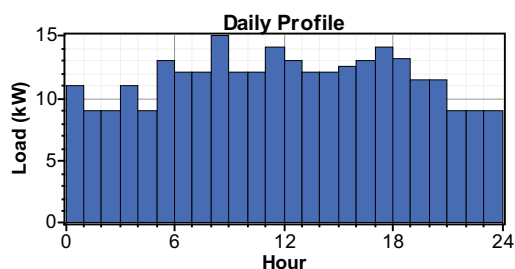

HOMER (National Renewable Energy Laboratory, 2011)

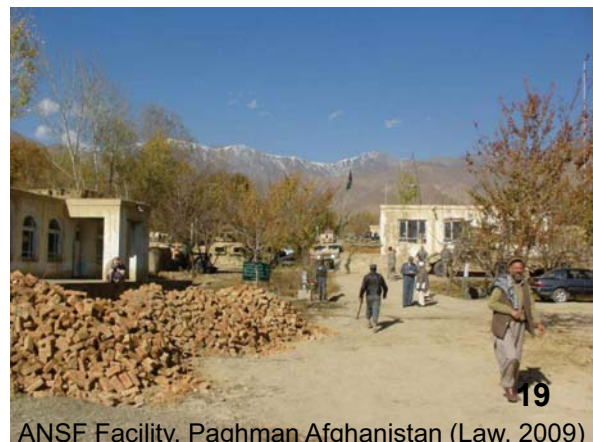



Approach

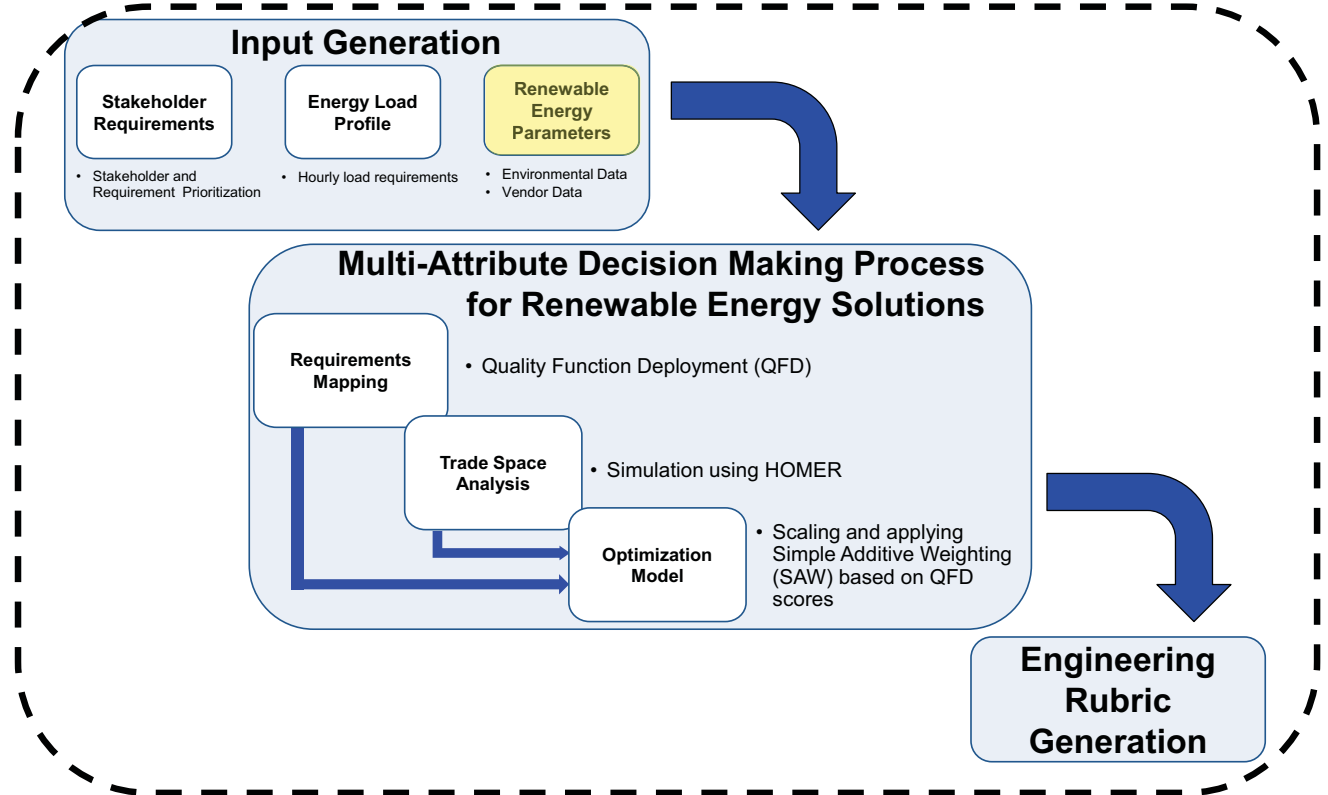

Renewable Energy Parameters

- 4 solar irradiance bands
- Actual solar irradiance waveform scaled to represent all values
- Sharp ND-224 - \$2,321 per kW
 - 44.4% derating factor

- Vendor rating
- Temperature effects
- Irradiance data

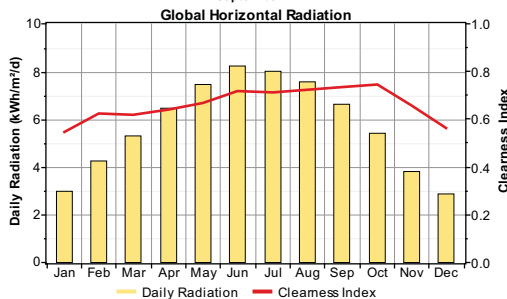
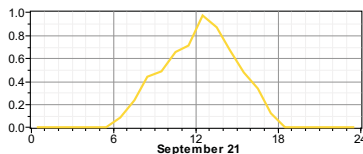

HOMER (National Renewable Energy Laboratory, 2011)

Geospatial Toolkit (National Renewable Energy Laboratory, 2011)

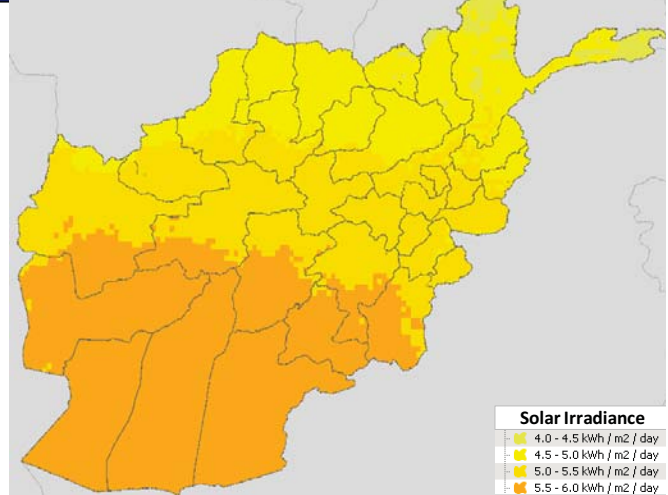

Sharp ND-224UC1 solar panel (Sharp, 2011)

	kWh/m ² /day	Annual Average
s1	4-4.5	4.25
s2	4.5-5	4.75
s3	5-5.5	5.25
s4	5.5-6	5.75

20
5.75



Renewable Energy Parameters

Geospatial Toolkit (National Renewable Energy Laboratory, 2011)

- 7 wind classes
- Actual wind waveform scaled to represent all values
- Southwest Windpower's Whisper 100
- 10 meter hub height
- O&M Costs \$55/year per turbine

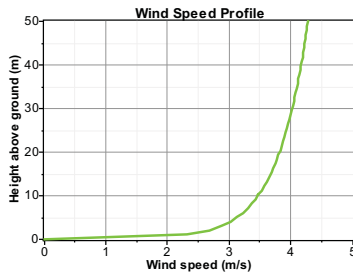
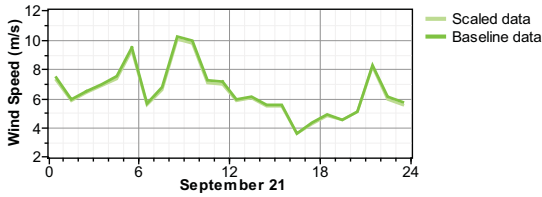
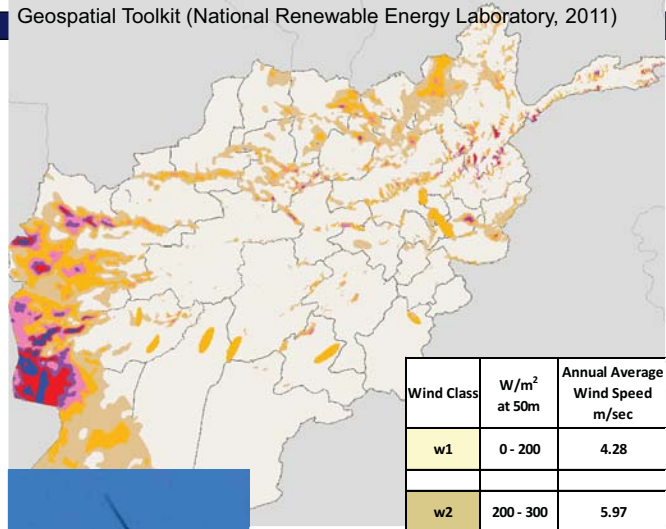

HOMER (National Renewable Energy Laboratory, 2011)



Southwest Windpower's Whisper 100 (Southwest Windpower, 2011)

Wind Class	W/m ² at 50m	Annual Average Wind Speed m/sec
w1	0 - 200	4.28
w2	200 - 300	5.97
w3	300 - 400	6.73
w4	400 - 500	7.48
w5	500 - 600	7.55
w6	600 - 800	7.85
w7	> 800	8.59



Energy Storage Parameters

The Rolls S2-3560AGM battery (Surrette Battery Company, 2011)

- 3560 amp hours
- Robust AGM technology
- 36 volt bus
- \$2,327 per battery

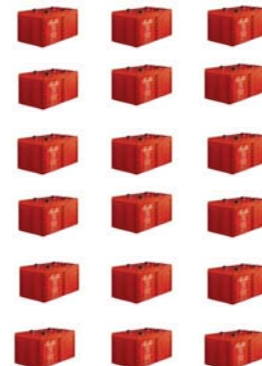

18 Batteries = 1 String



Approach

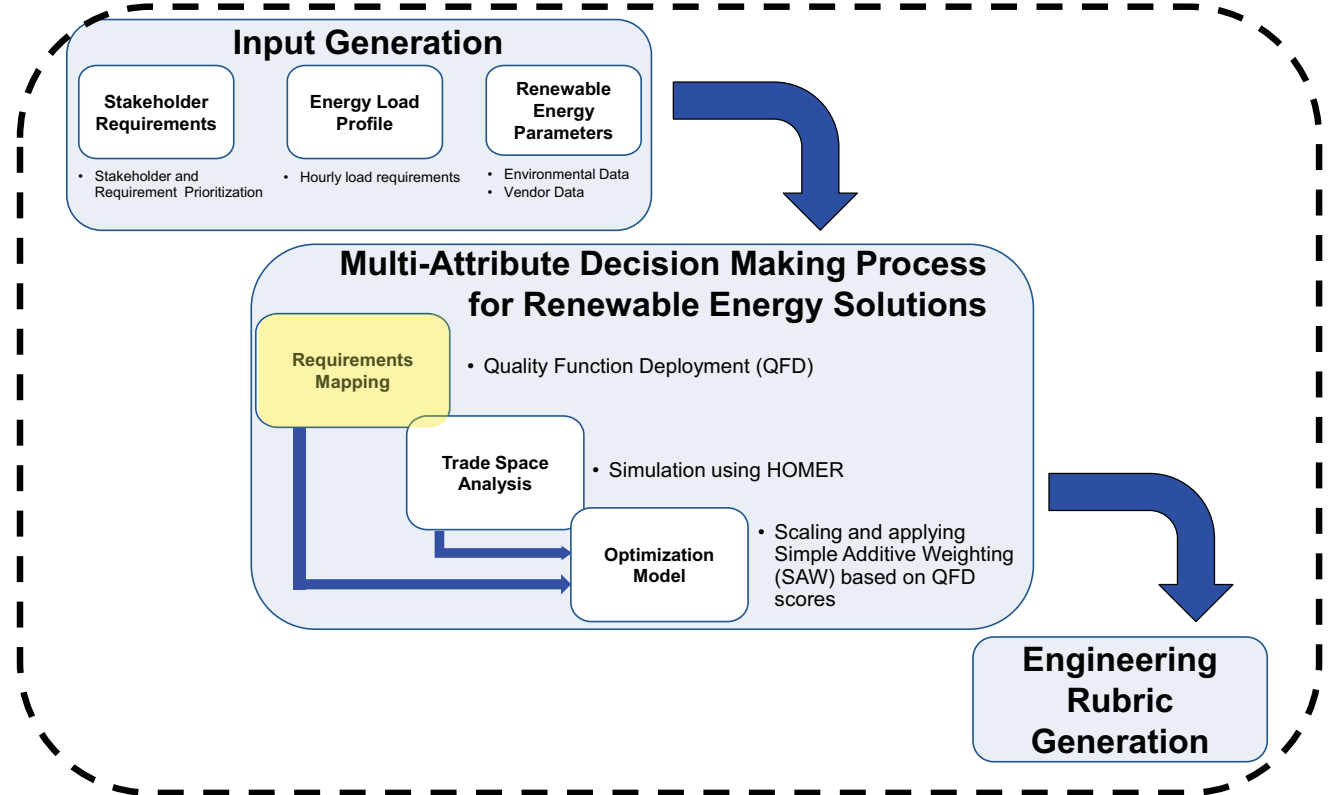

Requirements Mapping

Stakeholder Requirements	Weights
Security	0.61
Environment	0.05
Initial Cost	0.19
Life Cycle Cost	0.15

Logistics Burden	Environment & Logistics Benefit	Power Sources				Costs	
		Generator Electricity Production (kW)	Solar Electricity Production (kW)	Wind Electricity Production (kW)	Battery Quantity (#)	Initial Capital Cost (\$)	Life Cycle Cost (\$)
Total O&M Costs (\$)	Renewable Fraction (%)						

- Design attributes
- Requirement driven selection using HOMER outputs
- Correlation analysis

	PV	Wnd1	Gen	Rolls AGM 3560	Converter	Initial Capital Cost	Life Cycle Cost	Tot. Ann. Capital Cost	Tot. Ann. Repl. Cost	O&M Cost	Total Fuel Cost	Total Ann. Cost	Operating Cost	COE
PV	1.00													
W100	0.02	1.00												
Gen	-0.35	-0.08	1.00											
Rolls AGM 3560	0.09	0.01	-0.27	1.00										
Converter	0.07	0.02	-0.21	0.06	1.00									
Initial Capital Cost	0.84	0.21	-0.42	0.57	0.10	1.00								
Life Cycle Cost	-0.75	-0.18	0.30	-0.13	-0.11	-0.70	1.00							
Tot. Ann. Cap. Cost	0.84	0.21	-0.42	0.57	0.10	1.00	-0.70	1.00						
Tot. Ann. Repl. Cost	0.15	0.02	-0.09	0.55	0.03	0.40	-0.25	0.40	1.00					
O&M Cost	-0.36	0.55	0.00	0.24	-0.05	-0.06	0.58	-0.06	-0.15	1.00				
Total Fuel Cost	-0.80	-0.20	0.34	-0.29	-0.11	-0.82	0.98	-0.82	-0.40	0.48	1.00			
Total Ann. Cost	-0.75	-0.18	0.30	-0.13	-0.11	-0.70	1.00	-0.70	-0.25	0.58	0.98	1.00		
Operating Cost	-0.81	-0.20	0.34	-0.22	-0.11	-0.80	0.99	-0.80	-0.29	0.50	0.99	0.99	1.00	
COE	-0.75	-0.18	0.30	-0.13	-0.11	-0.70	1.00	-0.70	-0.25	0.58	0.98	1.00	0.99	1.00
PV Production	1.00	0.02	-0.35	0.09	0.07	0.84	-0.75	0.84	0.15	-0.36	-0.80	-0.75	-0.81	-0.75
Wind Production	0.02	1.00	-0.08	0.01	0.02	0.21	-0.18	0.21	0.02	0.55	-0.20	-0.18	-0.20	-0.18
Gen Production	-0.32	-0.19	0.35	-0.27	-0.11	-0.82	0.97	-0.82	-0.36	0.47	1.00	0.97	0.99	0.97
Tot. Electrical Production	0.95	0.19	-0.33	0.00	0.05	0.79	-0.60	0.79	0.04	-0.13	-0.66	-0.60	-0.67	-0.60
AC Primary Load Served	-0.08	0.00	0.27	-0.01	-0.06	-0.06	0.09	-0.06	0.04	0.07	0.09	0.09	0.09	0.09
Renewable Fraction	0.84	0.20	-0.30	0.16	0.08	0.79	-0.97	0.79	0.27	-0.49	-0.98	-0.97	-0.98	-0.97
Cap. Shortage	0.08	0.00	-0.27	0.01	0.06	0.06	-0.09	0.06	0.04	-0.07	-0.09	-0.09	-0.09	-0.09
Unmet Load	0.08	0.00	-0.27	0.01	0.06	0.06	-0.09	0.06	0.04	-0.07	-0.09	-0.09	-0.09	-0.09
Excess Electricity	0.94	0.18	-0.32	-0.03	0.05	0.76	-0.55	0.76	-0.01	-0.08	-0.60	-0.55	-0.62	-0.55
Diesel	-0.80	-0.20	0.34	-0.29	-0.11	-0.82	0.98	-0.82	-0.40	0.48	1.00	0.98	0.99	0.98
CO2 Emissions	-0.80	-0.20	0.34	-0.29	-0.11	-0.82	0.98	-0.82	-0.40	0.48	1.00	0.98	0.99	0.98
CO Emissions	-0.80	-0.20	0.34	-0.29	-0.11	-0.82	0.98	-0.82	-0.40	0.48	1.00	0.98	0.99	0.98
LHC Emissions	-0.80	-0.20	0.34	-0.29	-0.11	-0.82	0.98	-0.82	-0.40	0.48	1.00	0.98	0.99	0.98
PM Emissions	-0.80	-0.20	0.34	-0.28	-0.11	-0.82	0.98	-0.82	-0.40	0.48	1.00	0.98	0.99	0.98
SO2 Emissions	-0.80	-0.20	0.34	-0.29	-0.11	-0.82	0.98	-0.82	-0.40	0.48	1.00	0.98	0.99	0.98
NOx Emissions	-0.80	-0.20	0.34	-0.29	-0.11	-0.82	0.98	-0.82	-0.40	0.48	1.00	0.98	0.99	0.98
Gen Fuel	-0.80	-0.20	0.34	-0.29	-0.11	-0.82	0.98	-0.82	-0.40	0.48	1.00	0.98	0.99	0.98
Gen Hours	-0.74	-0.23	0.31	-0.31	-0.11	-0.78	0.96	-0.78	-0.45	0.49	0.98	0.96	0.97	0.96
Gen Starts	-0.46	-0.05	0.33	-0.25	-0.34	-0.50	0.50	-0.50	-0.30	0.17	0.55	0.50	0.53	0.50
Gen Life	0.58	0.13	-0.66	0.42	0.33	0.69	-0.50	0.69	0.13	-0.02	-0.56	-0.50	-0.56	-0.50
Battery Autonomy	0.09	0.01	-0.27	1.00	0.06	0.57	-0.13	0.57	0.55	0.24	-0.29	-0.13	-0.22	-0.13
Battery Throughput	0.58	0.01	-0.25	0.40	0.06	0.66	-0.85	0.66	0.60	-0.60	-0.89	-0.85	-0.89	-0.85
Battery Life	-0.20	0.02	-0.17	0.60	0.03	0.14	0.27	0.14	-0.26	0.55	0.21	0.27	0.26	0.27
True # of Batteries	0.28	-0.06	-0.22	0.83	0.06	0.63	-0.38	0.63	0.89	-0.14	-0.54	-0.38	-0.45	-0.38



Quality Function Deployment

Stakeholder Requirements	Weights	Logistics Burden	Enviro & Logistics Benefit	Power Sources				Costs	
		Total O&M Costs	Renewable Fraction	Generator Production	Solar Production	Wind Production	Battery Quantity	Initial Capital Cost	Life Cycle Cost
		\$	%	kW	kW	kW	#	\$	\$
Security (Attributes: energy independence and lives lost through logistics & sustainment convoys, i.e. fuel convoys, maintenance convoys, spares etc.)	0.61	-5	7	-9	-3	-3	-4	0	0
Environmental Impact	0.05	-3	9	-9	9	9	-3	0	0
Initial Cost	0.19	0	0	0	0	0	0	-9	0
Life Cycle Cost	0.15	0	0	0	0	0	0	0	-9
Check Sum	1.00								

Weighted Traits	-3.20	4.72	-5.94	-1.37	-1.37	-2.59	-1.72	-1.35
Absolute Values	3.20	4.72	5.94	1.37	1.37	2.59	1.72	1.35
Percent Impact of Traits	14.4%	21.2%	26.7%	6.2%	6.2%	11.6%	7.7%	6.0%

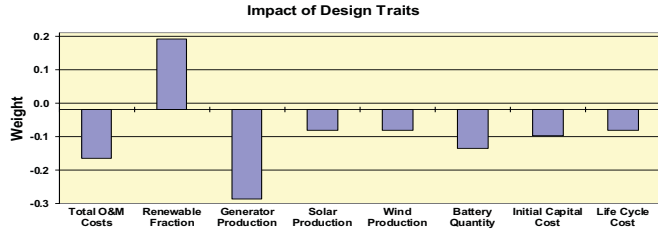

Approach

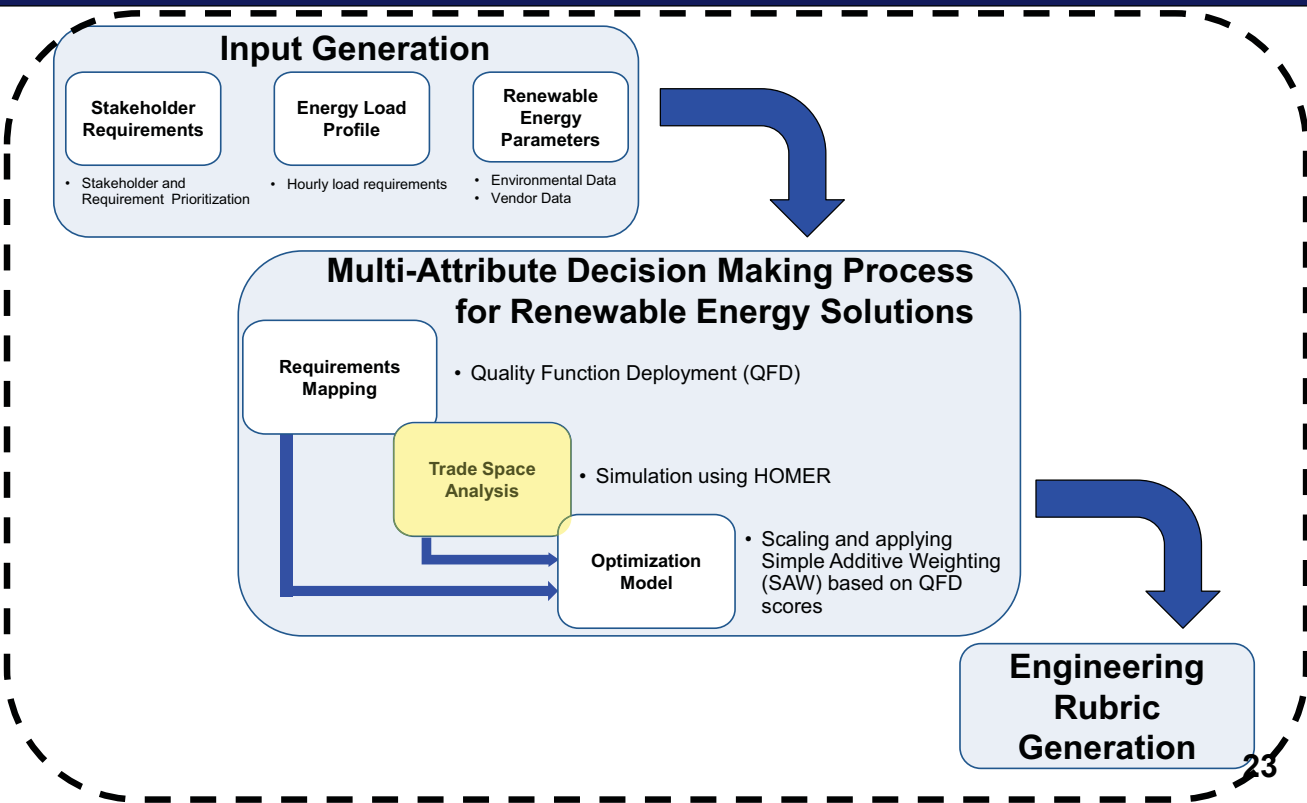



Trade Space Analysis

• HOMER Simulations

- 9,000 combinational designs per location
- 252,000 designs considered in solution set

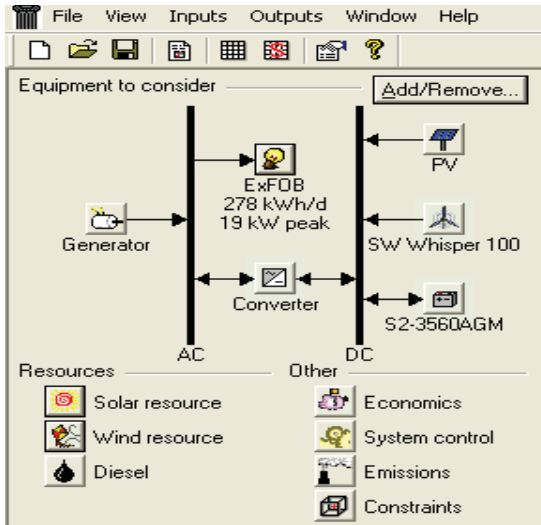

HOMER (National Renewable Energy Laboratory, 2011)

Wind Class	W/m ² at 50m	Annual Average Wind Speed m/sec
w1	0 - 200	4.28
w2	200 - 300	5.97
w3	300 - 400	6.73
w4	400 - 500	7.48
w5	500 - 600	7.55
w6	600 - 800	7.85
w7	> 800	8.59

PV Array (kW)	W100 (Quantity)	Gen (kW)	S2-3560AGM (Strings)	Converter (kW)
0	0	0	0	0
10	1	20	1	15
50	2		2	20
100	3		3	25
150	4		4	
200	5		5	
250	6		6	
300	8		7	
	10		8	
	12		9	
	14		10	
	16		11	
	18		12	
	20			

	kWh/m ² /day	Annual Average
s1	4-4.5	4.25
s2	4.5-5	4.75
s3	5-5.5	5.25
s4	5.5-6	5.75



Approach

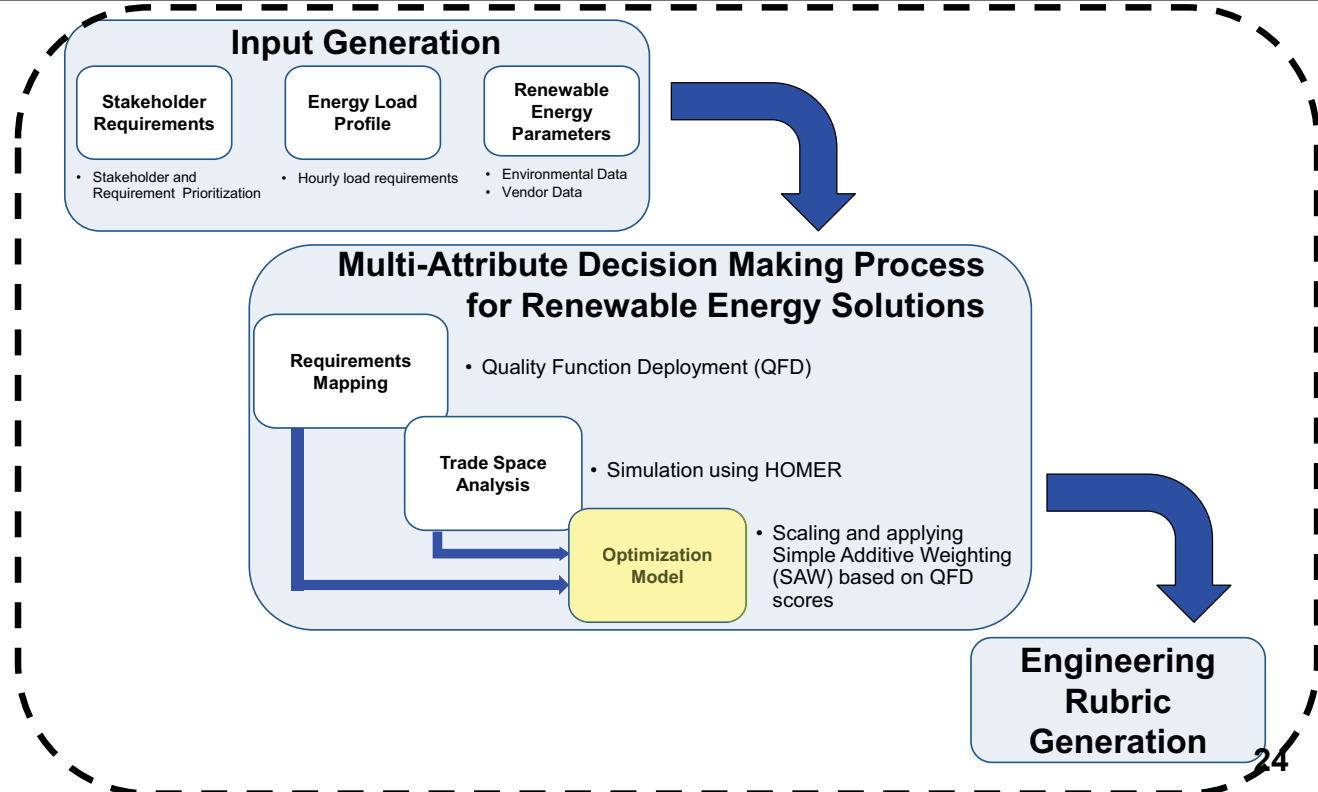



Optimization Model

- Scaling laws (Zeng, 2004)
- Simple Additive Weighting (SAW) technique

Logistics Burden	Environment & Logistics Benefit	Power Sources				Costs	
Total O&M Costs (\$)	Renewable Fraction (%)	Generator Electricity Production (kW)	Solar Electricity Production (kW)	Wind Electricity Production (kW)	Battery Quantity (#)	Initial Capital Cost (\$)	Life Cycle Cost (\$)
0.14	0.21	0.27	0.06	0.06	0.12	0.08	0.06

HOMER's Optimization Technique

SAW Technique

	0.062	0.062	0.267	0.116	0.077	0.060	0.144	0.212	← QFD Scores	
#	PV Production kWh/yr	Wind Production kWh/yr	Gen Production kWh/yr	True # of Batteries	Total Capital Cost \$	Total NPC \$	Total O&M Cost \$/yr	Ren. Fraction %		SAW Score
1	0.499998211	0.416657577	1	0.312714777	0.437590383	0.998852642	0.526494202	1		0.744332895
2	0.499998211	0.333322945	1	0.329501916	0.45496921	0.998691771	0.543443354	1		0.739995307
3	0.499998211	0.416657577	1	0.312714777	0.434782365	0.998691771	0.543443354	1		0.744036998
4	0.499998211	0.333322945	1	0.333333333	0.425565044	0.997608597	0.494380018	1		0.733479912
5	0.499998211	0.333322945	1	0.329501916	0.452161191	0.997544412	0.526494202	1		0.739699406
6	0.499998211	0.333322945	1	0.333333333	0.41292896	0.997157871	0.494380018	1		0.732477113
7	0.499998211	0.333322945	1	0.333333333	0.422757025	0.996300368	0.494380018	1		0.733184012

	0.062	0.062	0.267	0.116	0.077	0.060	0.144	0.212	← QFD Scores	
#	PV Production kWh/yr	Wind Production kWh/yr	Gen Production kWh/yr	True # of Batteries	Total Capital Cost \$	Total NPC \$	Total O&M Cost \$/yr	Ren. Fraction %		SAW Score
2727	0.499998211	0.983326841	0.907032614	0.137931034	0.653747441	0.924238794	0.991436218	0.94		0.797804975
2781	0.499998211	0.983326841	0.907032614	0.137931034	0.650939423	0.922930565	0.991436218	0.94		0.797509075
2188	0.499998211	0.983326841	0.922545155	0.122807018	0.624343275	0.933955465	0.968421053	0.95		0.797318035
2834	0.499998211	1	0.904443921	0.137931034	0.656152509	0.921519312	1	0.93		0.797269666
2259	0.499998211	0.983326841	0.922545155	0.122807018	0.621535256	0.932647235	0.968421053	0.95		0.797022135
2887	0.499998211	1	0.904443921	0.137931034	0.653344491	0.920221083	1	0.93		0.796973768
2348	0.499998211	1	0.920329078	0.099099099	0.626748343	0.931201846	0.976984835	0.95		0.79624936



Approach

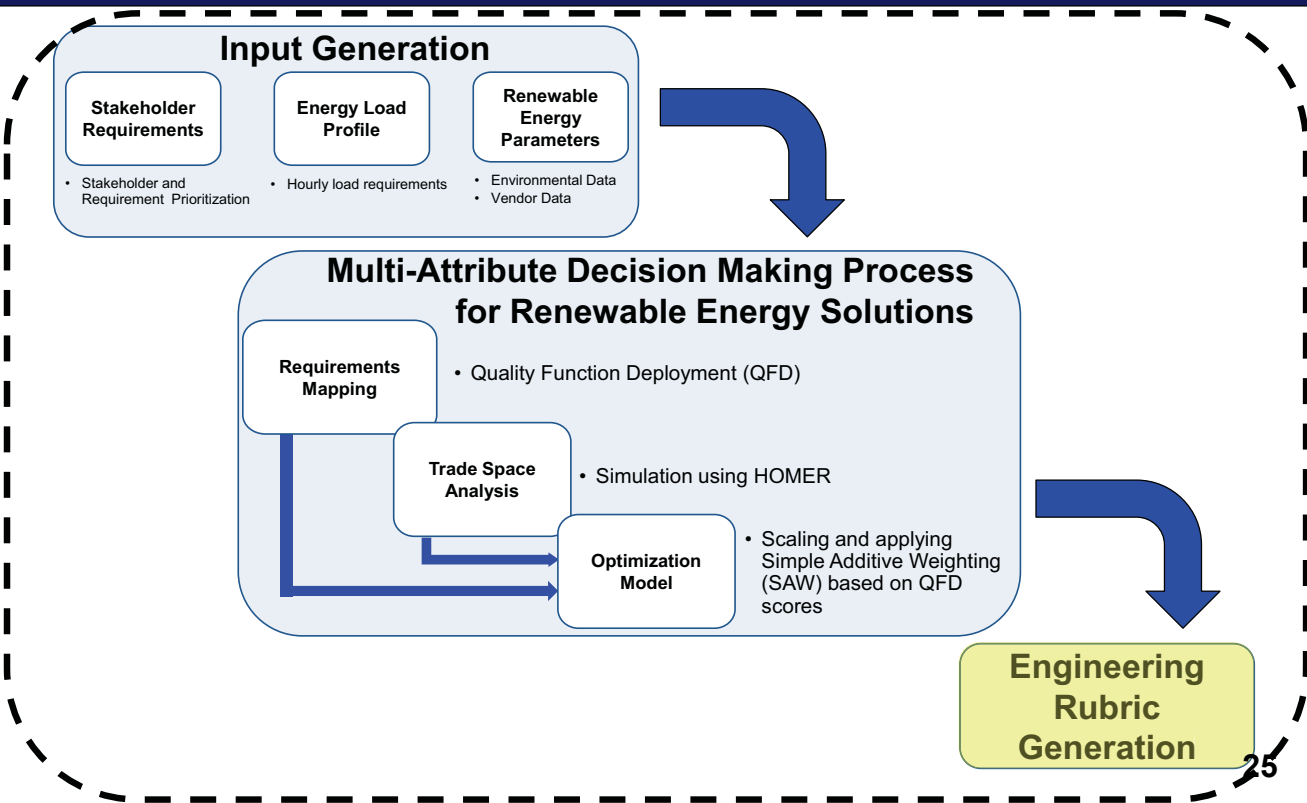



Engineering Rubric Generation

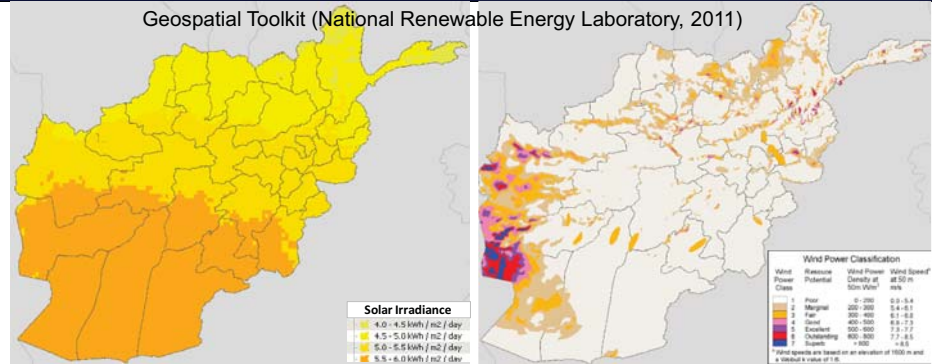

- All designs include 20-kW generator with auto on/off controller

		Poor	Marginal	Fair	Good	Excellent	Outstanding	Superb	Scale
		1	2	3	4	5	6	7	Wind Class
		FBCF = \$4.82/liter							W/m2 at 50m
		0 - 200	200 - 300	300 - 400	400 - 500	500 - 600	600 - 800	> 800	m/sec
		(4.28)	(5.97)	(6.73)	(7.48)	(7.55)	(7.85)	(8.59)	
s1	4.0 - 4.5 (4.25)	1270 200kW PV 54 Batteries 1 Wind Turbine	2172 200kW PV 54 Batteries 2 Wind Turbines	2185 200kW PV 54 Batteries 5 Wind Turbines	1011 200kW PV 54 Batteries 14 Wind Turbines	1188 150kW PV 54 Batteries 16 Wind Turbines	861 150kW PV 54 Batteries 18 Wind Turbines	615 150kW PV 54 Batteries 18 Wind Turbines	
	4.5 - 5.0 (4.75)	1342 200kW PV 54 Batteries	2465 200kW PV 54 Batteries	1878 150kW PV 54 Batteries 10 Wind Turbines	975 150kW PV 54 Batteries 14 Wind Turbines	972 150kW PV 54 Batteries 14 Wind Turbines	1155 150kW PV 54 Batteries 12 Wind Turbines	605 150kW PV 54 Batteries 16 Wind Turbines	
s3	5.0 - 5.5 (5.25)	1571 150kW PV 54 Batteries 1 Wind Turbines	2727 150kW PV 54 Batteries 1 Wind Turbines	1743 150kW PV 54 Batteries 8 Wind Turbines	1398 150kW PV 54 Batteries 10 Wind Turbines	1803 150kW PV 54 Batteries 8 Wind Turbines	1174 150kW PV 54 Batteries 12 Wind Turbines	642 150kW PV 54 Batteries 16 Wind Turbines	
	5.5 - 6.0 (5.75)	530 150kW PV 90 Batteries	2203 150 kW PV 54 Batteries 2 Wind Turbines	1874 150 kW PV 54 Batteries 6 Wind Turbines	1430 150 kW PV 54 Batteries 10 Wind Turbines	1742 150 kW PV 54 Batteries 8 Wind Turbines	635 100 kW PV 54 Batteries 20 Wind Turbines	747 100 kW PV 54 Batteries 16 Wind Turbines	
		kWh/m ² /day							



Benefits

- USACE plans to construct 600 facilities for ANP alone
- \$3 million can be saved per installation
- \$1.8 billion could be saved over next 25 years
- Applicable to any country
- Provides energy independence
- Improves environment
- Reduces logistics
- Saves money
- Saves lives

Afghanistan Logistics Convoy (Defense Imagery, 2009)



Phuong Lam presentation (next 9 pages) and Glen R. Grogan presentation (next 13 pages) out to obtain Distribution A Statements



A Software Assurance Framework for Mitigating the Risks of Malicious Software in Embedded Systems Used in Aircraft

Robert Ginn
September 20, 2011



Malicious Software Represents a Significant Risk to Systems

- Software directly controls many safety critical system elements – there is often no "man in the loop"
- It is easy to write software that will fail in predetermined ways
- It is difficult to detect malicious code in software
- It is possible to compromise most existing software if it is accessible across a network.



CIA Sabotages Pipeline Software

"The pipeline software that was to run the pumps, turbines and valves was programmed to go haywire," ... "to reset pump speeds and valve settings to produce pressures far beyond those acceptable to the pipeline joints and welds. The result was the most monumental non-nuclear explosion and fire ever seen from space."

- Reed in Safire (2008)

3



Stuxnet Worm Had Two Main Functions

"One was designed to send Iran's nuclear centrifuges spinning wildly out of control. Another seems right out of the movies: The computer program also secretly recorded what normal operations at the nuclear plant looked like, then played those readings back to plant operators, like a pre-recorded security tape in a bank heist, so that it would appear that everything was operating normally while the centrifuges were actually tearing themselves apart."

- Broad, Markoff, & Sanger (2011)

4

29



Avionics Risks

- Many subsystems in aircraft are safety critical
 - For example in many modern A/C, a Full Authority Digital Engine Controller (FADEC) controls the engines, not the pilot.
 - The FADEC has no form of manual override and all the engine operating parameters are controlled by it.
 - Thus the FADEC can speed up, slow down, stop, or in some cases reverse the engine

5



Chinook Crash Blamed on FADEC Software

- In 1994, the crash of a Boeing Chinook helicopter killed 25 intelligence personnel and a four-person Special Forces crew. A 1993* review of the FADEC software by EDS-SCICON had found 485 anomalies after examining only 18 per cent of the software code. "Errors caused unexpected engine shutdowns, as well as surges in power that resulted in engines completely blowing out"

- King (2011)

* The review has been concealed prior to the crash

6



When F-22 Raptors crossed the international dateline the first time ...

"... all systems dumped and when I say all systems, I mean all systems, their navigation, part of their communications, their fuel systems. They were -- they could have been in real trouble. They were with their tankers. The tankers - they tried to reset their systems, couldn't get them reset. The tankers brought them back to Hawaii. This could have been real serious. It certainly could have been real serious if the weather had been bad. It turned out OK. It was fixed in 48 hours. It was a computer glitch in the millions of lines of code, somebody made an error in a couple lines of the code and everything goes."

- General Shepperd (as stated in Roberts, 2007)



The Problem is Not Getting Better

Total Vulnerabilities by Vendor

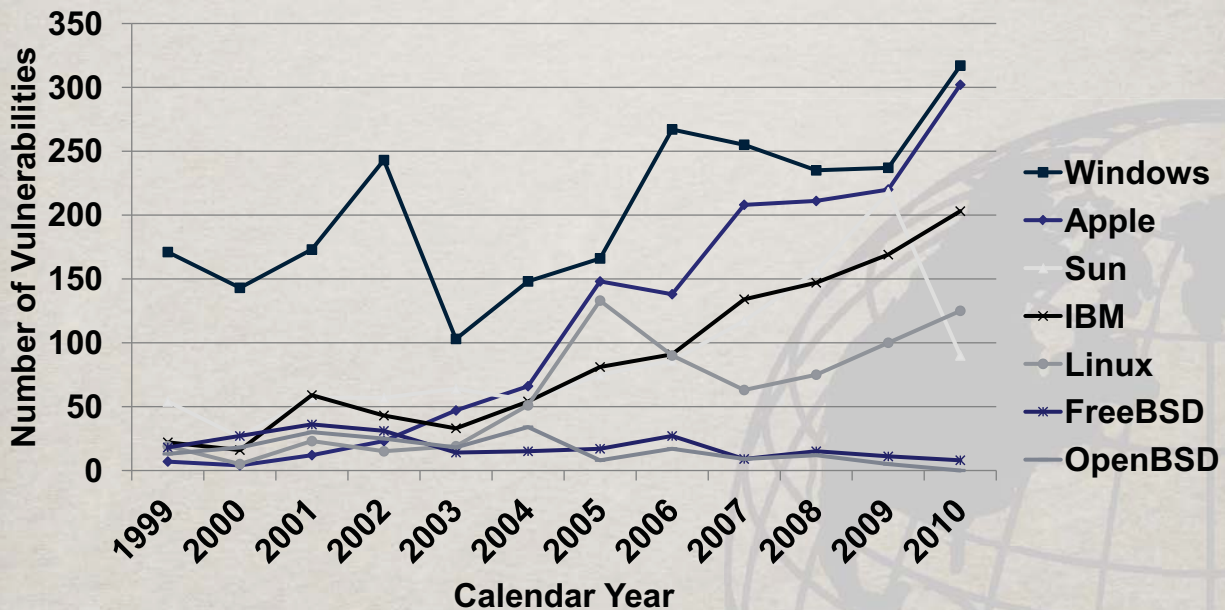



Motivations

- Malicious Code is Big Business
 - Underground Economy size is unknown
 - Assumed to be bigger than Legitimate Market
 - Security firms pay for security flaws
 - Example: Netragard (a cybersecurity firm) pays between \$15,000 and \$115,000 for a security flaw in the Apple Mac.
- Attackers want fame – who can write the best malicious code?

<http://underhanded.xcott.com>

9



Motivations (Cont)

- Espionage
 - SecurID is a security token sold by RSA which is intended to allow employees to securely access their internal networks
 - Attackers breached RSA security in March to steal the ability to bypass this security
 - At least three defense contractors have since been attacked using the data stolen from RSA
 - Was their software modified? They say no, but it doesn't seem that they can be sure ...

10

32



Broad Categories of Malicious Code

- Vulnerabilities (Exploitable)
 - A coding error in the system software
 - Accidental or Deliberately inserted
 - Allow real-time exploit of the system
- Embedded Malicious Code (Pre-Exploited)
 - Deliberately inserted into the system's software
 - No further action required to cause harm
 - Can be disguised as a simple coding error

11



How Hard is it to Write Malicious Code?

- Unfortunately, It's Pretty Easy ...
- Actual requirements depend on the type of attack, but in general the attacker only needs:
 - Basic programming skills
 - Access to the source code
- More complicated attacks may also require:
 - Better programming skills
 - or a tool that will insert the code for them
 - Knowledge of the specific system environment

12

33



Notional System Architecture for an Aircraft

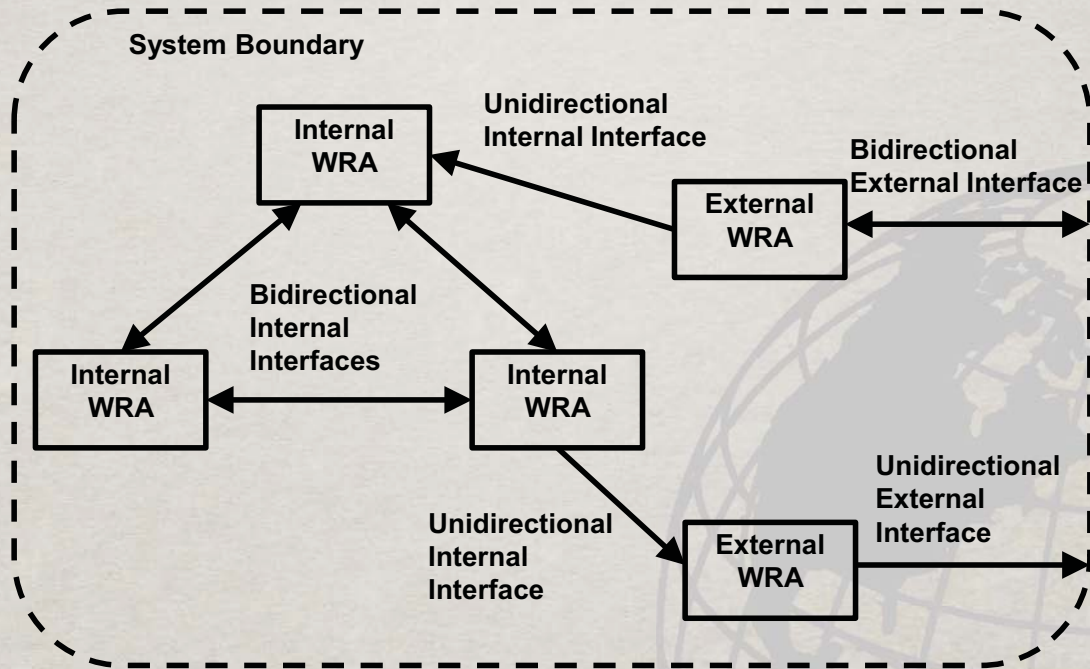

Note: WRA = Weapons Replaceable Assembly



Exploiting Vulnerabilities in A/C is Hard (Need a Connection to Use)

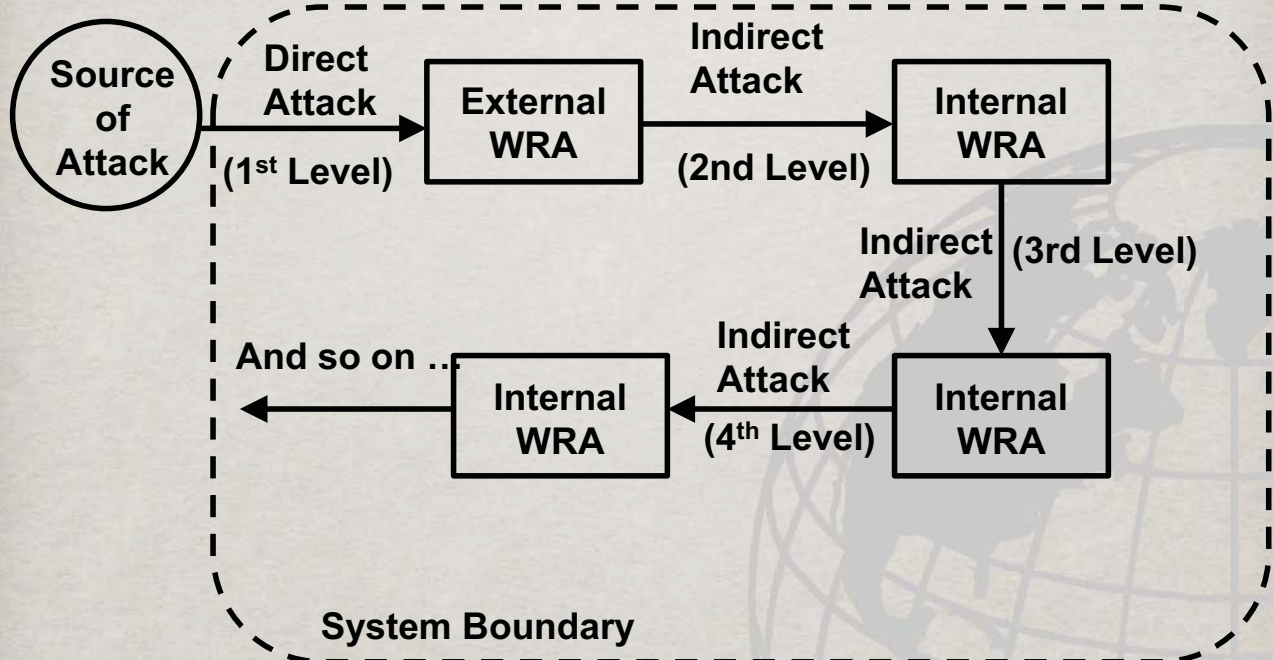



Simplified Weapons Replaceable Assembly (WRA) Model

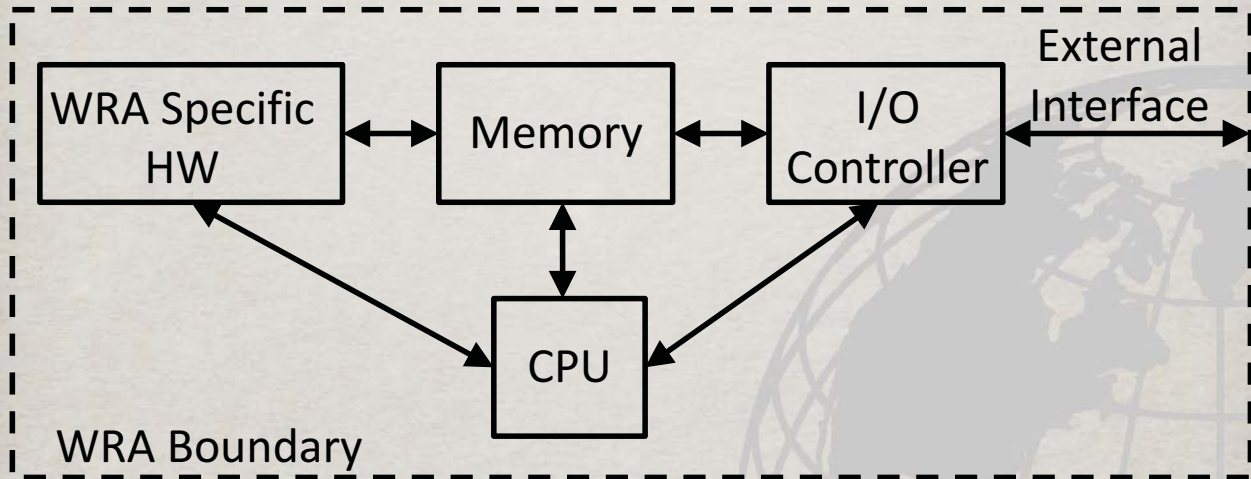

What's in the WRA's Memory?

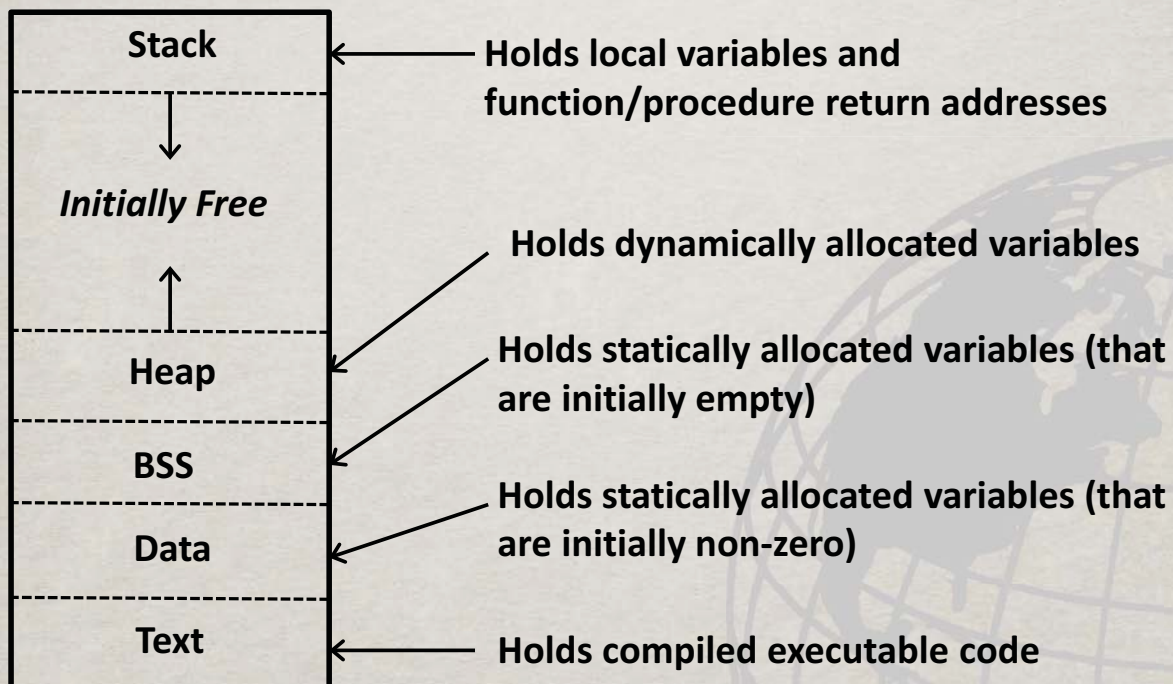



Basic CPU Operation (Data vs Code, Execution Threads)

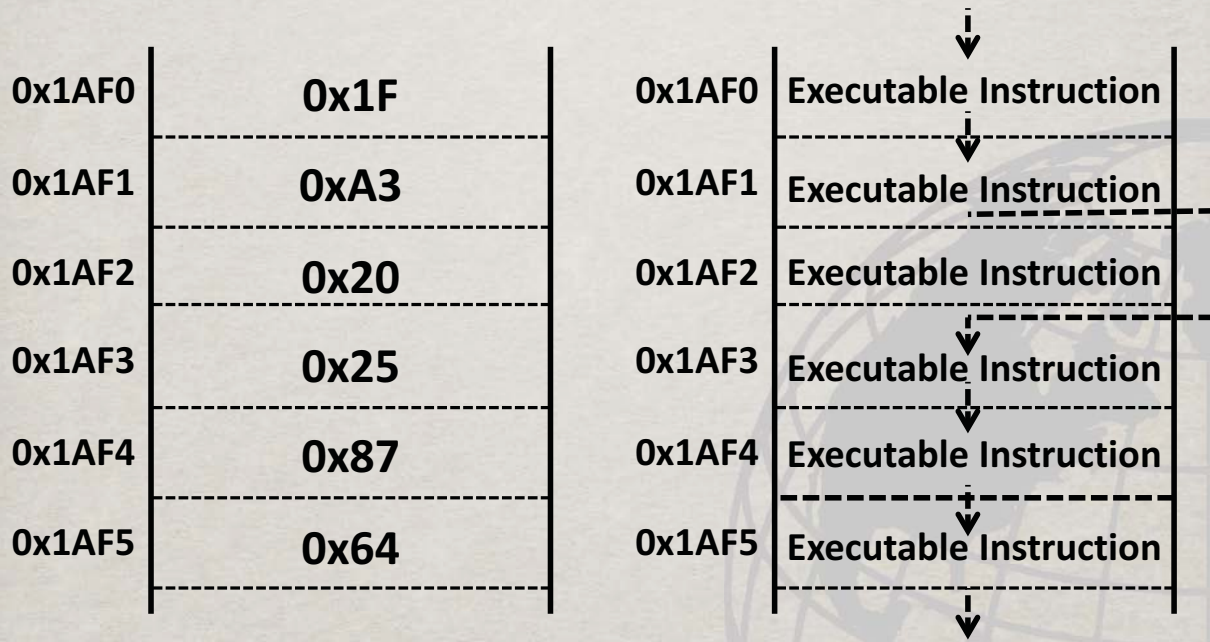

Inert Malicious Code (If the code is never executed ...)

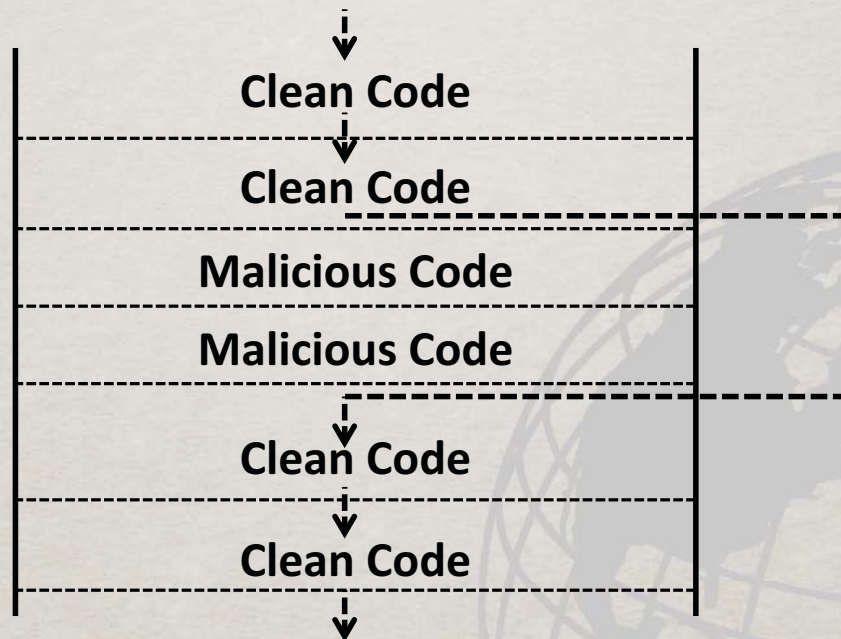

Simple Subroutine

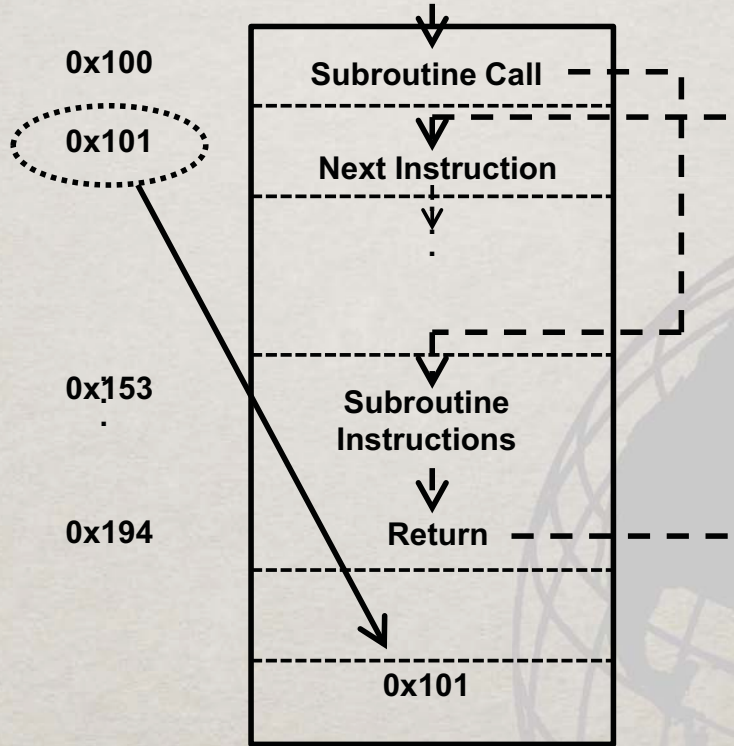

Sample Buffer Overflow Attack

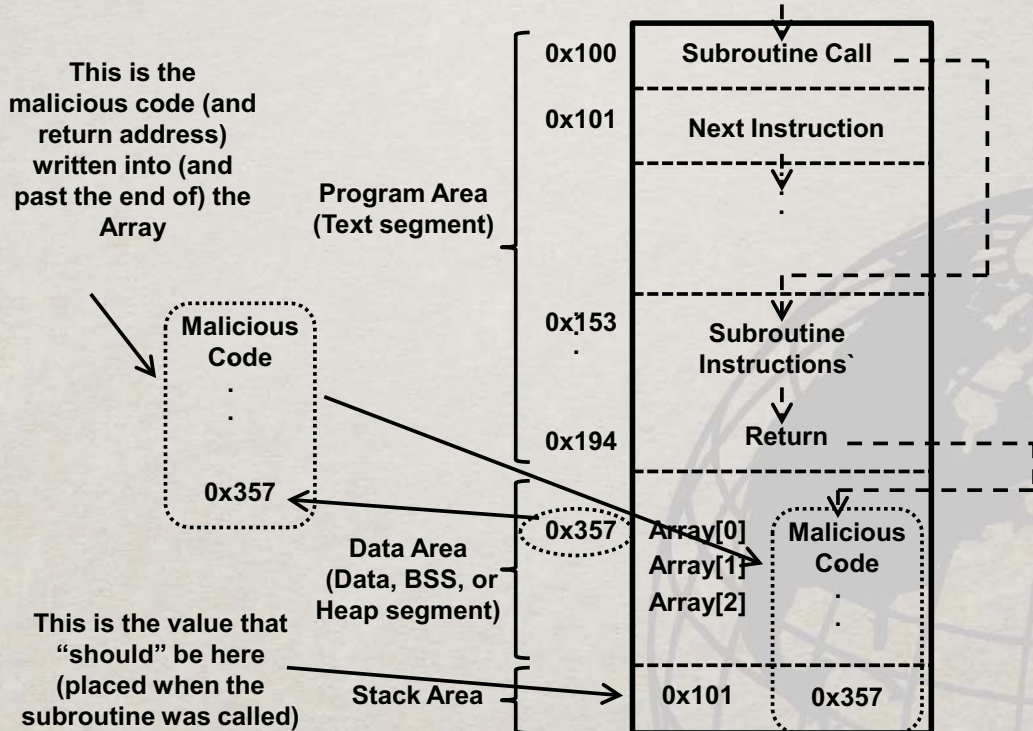



You May be Familiar with this Buffer Overflow Example from 2004

- Microsoft code assumed that the file size information was correct in image files – so they only allocated a buffer large enough to hold the reported image size, not the actual image size
- Attackers deliberately corrupted the image size information in the file, including malicious code in the “image data”
- Programs such as Microsoft Outlook[®] used the broken routine, thus allowing attackers to email the image file and when the auto-preview feature in Microsoft Outlook[®] tried to display the file, control was transferred to the malicious code
 - From a Microsoft Security Bulletin (2004)

21



Some Basic Defense Techniques (Non-Systems Engineering)

- Insert random “canaries” around buffers
 - An overflow will overwrite the canary and the program can terminate instead of returning from a subroutine
- Burn the program into Read Only Memory (ROM)
 - Prevents an attacker from overwriting *any* code
- Randomize Address Layout
 - Attacker can’t hardcode a jump to malicious code
- Source Code Walkthroughs
 - Multiple people read the code looking for problems

22

38



Unfortunately, Attackers Can Get Around All of These Defenses

- Insert random “canaries” around buffers
 - Only handles stack based overflows, and even then not completely
- Burn the program into Read Only Memory (ROM)
 - Techniques such as Return Oriented Programming allow execution of arbitrary code without changing ROM
- Randomize Address Layout
 - Attacker can still use relative addressing or calculate the jump
- Source Code Walkthroughs
 - Even experienced programmers find it difficult to spot malicious code. Special tools exist to insert code that is difficult to spot either by a human or by a scanner. If found, the malicious code will often look like a simple programming error

23



Observation About Overt and Covert Embedded Malicious Code

For covert malicious code, this “if” test will be hidden

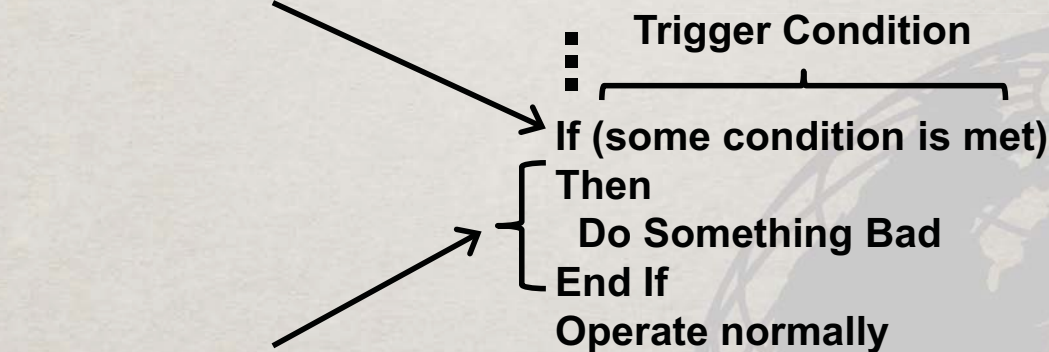

For covert malicious code, this code will be hidden (not just in text segment, may be anyplace in memory)

24

39



Implicit Attacker Requirements (System Level)

- Execution thread must pass through the malicious code
 - Or it will never get a chance to cause harm
- Problem must occur during use and not during testing
 - Or the problem will be discovered before it can cause harm
- Some trigger must be present
 - To control when the problem will occur

25



Relaxing Our Requirements

- We don't actually need to be certain that no malicious code is present in the system
 - For example, if malicious code is present but inert, does it matter?
- We only need to make sure that if malicious code is present, that it can do no harm
 - This is a much easier problem to solve

26

40



What If Trigger Information is Not Available to WRA (Malicious Code)?

- Malicious Code has a Choice, it can either ...
 - Always do something bad ...
 - And be detected
 - Never do something bad ...
 - And never cause harm
 - Note that (unfortunately) there is a third option but it's not ideal for the attacker
 - Requires some source of random information

27



A Systems Engineer Can Often Control the Information Available

- For example, if a WRA does not need to know the altitude, there is no reason to provide it this information.
- The same thing applies to Lat/Long, how many hours the WRA has been used, and many other bits of information.
- Basically all WRA inputs must be scrutinized to determine if they can be used as triggers
- Sometimes the WRA needs the potential trigger information
 - And thus we must use other techniques to reduce the risk

28

41



A Systems Engineer Can Leverage Existing Development Practices

- Code Walkthroughs
 - Safety Critical code typically require these anyway
 - Can prevent overt malicious code when combined with simple enhancement to development process
- DO-178B Statement Coverage
 - Require every single line of code to be executed
 - Can detect non-trigger based attacks
- Minor changes to the development process
 - E.g. check code into CM before review or test
- And many more ...

29



Additional Sub-Topics Available in the Thesis

- Discussion of protecting the software development process including
 - Discussion of protecting the CM system
 - Software Delivery
 - And many more ...
- How to certify source code as clean given a clean load image
- An approach to formally document Software Assurance Activities using Goal Structuring Notation (GSN)

30

42



Summary

- Malicious Software represents a significant and growing risk to systems
- As Systems Engineers, we need to be aware of these risks
- A Systems Engineer has the ability to reduce this risk at the system level
 - Most of these techniques are not available at the WRA level
- Basic defenses should be integrated into the systems development process

31



Questions?

Questions?

32

43



INVESTIGATING THE LINK BETWEEN COMBAT SYSTEM CAPABILITY AND SHIP DESIGN

Savannah G. Welch, LT USN

Co-advisors:

Dr. Clifford Whitcomb Dr. Eugene Paulo

September 21, 2011



Research Motivation

- Current conceptual ship design tools lack an early integration of naval architecture and combat system aspects.
- **Problem:** Difficult to conduct trade-off analysis based on impacts on both ship's naval architecture and warfighting effectiveness



Combat System Background

$$R = \left[\frac{\pi P_T L_T L_R D_T^2 D_R^2 \sigma}{64 k T B F \lambda^2 \cdot CNR} \right]^{1/4}$$

Radar Range Equation Variable	
Symbol	Meaning
P_T	Source Radiated Power
L_T	Loss Factor of the Transmitter
L_R	Loss Factor of the Receiver
D_T	Transmitter Antenna Diameter
D_R	Receiver Antenna Diameter
σ	Radar Cross Section of Target
k	Boltzmann's Constant
T	Receiver Temperature
B	Receiver Bandwidth
F	Receiver Noise Figure
CNR	Carrier to Noise Ratio

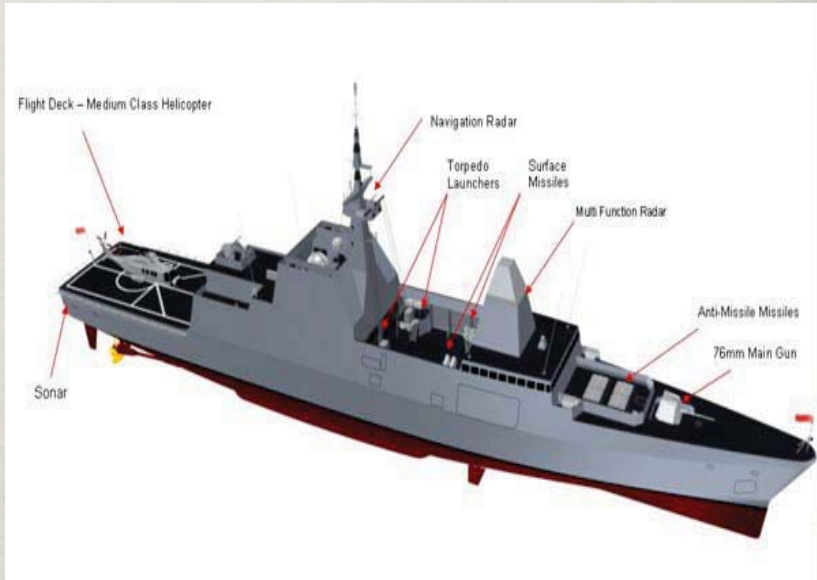

Current Ship Synthesis Tool

A	B	C	D	E	F	G	H	I	J	K	L	M
PAYLOAD NAME	WT KEY	WT	VCG DATUM	VCG FT AD	AREA KEY	HULL FT2	DKHS FT2	CRUISE KW	BATTLE KW	WT MOMENT		
STEEL LANDING PAD (ON HULL) - SH-60 CAPABLE	W111	10.7	37.14	0.20	NONE	0	0	0	0	399.538		
64 CELL VLS ARMOR - LEVEL III HY-80	W164	28	38.31575	-10	NONE	0	0	0	0	792.841		
MK45 GUN HY-80 ARMOR LEVEL II	W164	9	47.106	-8.00	NONE	0	0	0	0	351.954		
SQS-53C 5M BOW SONAR DOME W/MINE AVOIDANCE	W165	85.7	0	-1.5	NONE	0	0	0	0	-128.55		
GROUP 100	WP100	133.4				0	0	0	0			
CIC W/UHQ-44 & 2X LSD	W410	19.34	0	35.58	A1131	1953	448	45.03	45.03	688.1172		
NAVIGATION SYSTEM	W420	7.29	51	14.00	A1132	0	848.3	55.99	53.5	473.85		
ADV DIGITAL C4I (JTIDS, LINK 16/LINK 22/TADIXS/TACINTEL)	W440	37.91	51	-46.84	A1110	1230.6	1270.4	35.76	39.67	157.7056		
SPS-67 SURFACE SEARCH RADAR	W451	1.81	51	-10.00	A1121	0	70	8	0	74.21		
SPS-49(V)5 2-D AIR SEARCH RADAR	W452	9.03	51	-7.1	A1121	0	553	15.3	48.4	396.417		
MK XII AIMS IFF	W455	2.32	51	-5.00	NONE	0	0	3.2	4	106.72		
X-BAND RADAR AND FOUNDATION, 110 FT ABOVE BL	W456	4.11	0	113.00	NONE	0	0	220.16	220.16	464.43		
SQS-53C 5M BOW SONAR DOME ELEX W/MINE AVOIDANCE	W463	57.7	0	9.3	A1122	1942	0	39	39	536.61		
SSQ-61 BATHY THERMOGRAPH	W465	0.31	37.14	-10.90	A1122	85.5	0	0	0	8.1344		
SSQ-28 SONOBUOY PROCESSING SYSTEM	W466	5.26	51	-44.86	NONE	0	0	1.15	1.15	32.2964		
SLQ-32(V)3 ACTIVE ECM	W472	4.4	33.4	20.60	NONE	0	0	6.4	6.4	237.6		
AN/SLQ-25A NIXIE	W473	0.24	37.14	-6.20	A1142	200	0	3	4.2	7.4256		
SLQ-32(V)3 - MK36 DLS W/6 LAUNCHERS	W474	0.96	33.4	5.39	NONE	0	0	2.4	2.4	37.2384		
MK 86 57/54 GFCS	W481	7.50	51	-4.00	A1212	0	168	6	15.4	352.5		
MK92 MFCS - STIR/CORT/ADT/CEC	W482	6.29	51	-1.40	NONE	0	0	50.3	85.8	311.984		
VLS WEAPON CONTROL SYSTEM	W482	0.7	35.0585	2.54	A1220	56	310	13.62	19.69	26.31895		
ADVANCED TOMAHAWK WEAPON CONTROL SYSTEM	W482	5.6	33.4	-7.80	NONE	0	0	13.27	13.27	143.36		
ASW CONTROL SYSTEM [ASWCS] W/SSTD	W483	3.75	33.4	-12.60	A1240	320	0	8.61	8.61	78		
COMBAT DF	W495	8.26	33.4	21.00	A1141	0	448	15.47	19.34	449.344		
ELECTRONIC TEST & CHECKOUT	W499	1.1	38.31575	10.80	NONE	0	0	0	0	54.027325		
GROUP 400	WP400	183.88				5787.1	4115.7	542.66	626.02			
64-CELL VLS MAGAZINE DEWATERING SYSTEM	W529	7	35.0585	-0.46	NONE	0	0	0	0	242.1895		
LAMPS MKIII AVIATION FUEL SYS	W542	4.86	35.0585	-11.00	A1380	30	0	2	2.9	116.92431		
LAMPS MKIII RAST/RAST CONTROL/HELO CONTROL	W588	31.1	35.0585	-1.60	A1312	219	33	4.4	4.4	1040.55935		
GROUP 500	WP500	42.96				249	33	6.4	7.3			
SQS-53C 5M BOW SONAR DOME HULL DAMPING	W636	6.7	0	-2.5	NONE	0	0	0	0	-16.75		
LAMPS MKIII AVIATION SHOP AND OFFICE	W665	1.04	35.0585	-4.50	A1360	194	75	0	0	31.78084		
GROUP 600	WP600	7.74				194	75	0	0			
1X MK45 5IN/54 GUN (JERGM)	W710	36.8	47.106	-6.20	A1210	270	0	36.18	37.88	1505.3408		
2X HARPOON SSM QUAD CANNISTER LAUNCHERS	W721	4.1	33.4	1.17	A1220	0	0	0	1.6	141.737		

Research on Existing Combat Systems

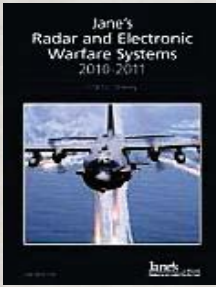

Analysis of Combat System Relationships

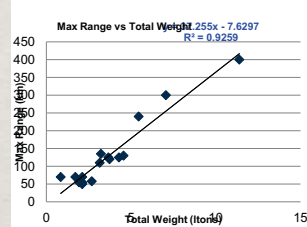

Implement equation into Ship Synthesis Model

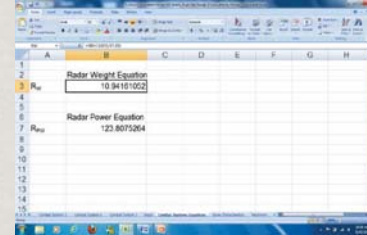

Evaluate impacts that Combat System Parameter has on both Ship Design and Warfighting Effectiveness

Ship Synthesis Results		
Air Search Radar Range	Total Ship Full Load Weight	Ship Survivability in AAW
High (400 km)	4840 Itons	96%
Med (135 km)	4826.7 Itons	55%
Low (55 km)	4822.7 Itons	18%

Run both Ship Synthesis Model and Operational Model with Performance Variable as Input

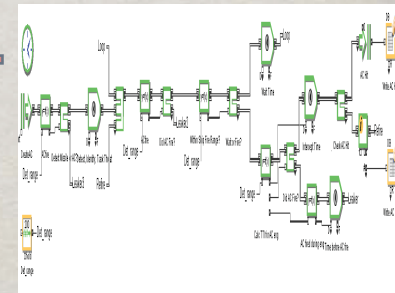

Construct Operational Model

- Integrate Combat System and Naval Architecture
- Focus on one combat system
- Displacement Range for ship 4000 – 5000 LT
- Considers one MOE for one mission area in operational model
- Monohull



Air Search Radars Used in Analysis

Air Search Radar	Maximum Range	Total Weight	Power
DA05	135 km	3.2213 LT	Not Available
DA08	125 km	4.2843 LT	Not Available
EL/M-2228S (2D HP AMDR)	70 km	1.7096 LT	15 kW
EL/M-2228S (3D AMDR)	70 km	2.116 LT	21 kW
Fregat-MAE	130 km	4.5539 LT	30 kW
Fregat-MAE-1	125 km	3.6603 LT	30 kW
Fregat-MAE-4K	58 km	2.679 LT	30 kW
MW08	55 km	2.116 LT	Not Available
Podberozovik-ET1	300 km	7.0538 LT	45 kW
Podberozovik-ET2	240 km	5.4466 LT	45 kW
Pozitiv-ME1	110 km	3.1495 LT	45 kW
Pozitiv-ME1.2	50 km	2.116 LT	45 kW
RAN 20S	120 km	3.7252 LT	Not Available
RSR 210N	55 km	1.929 LT	Not Available
SMART-L	400 km	11.3863 LT	140 kW
VARIANT	70 km	0.8464 LT	8.1 kW

7



Range (Performance) vs Weight (Physical)

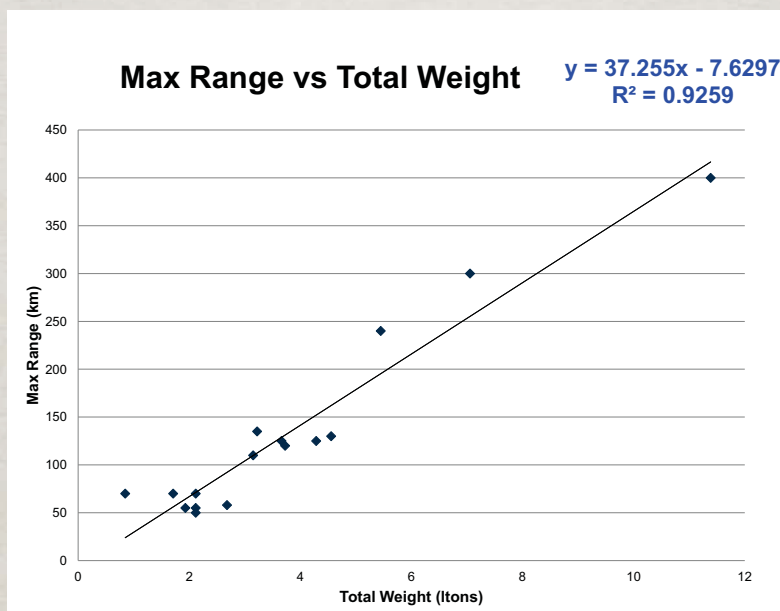

8

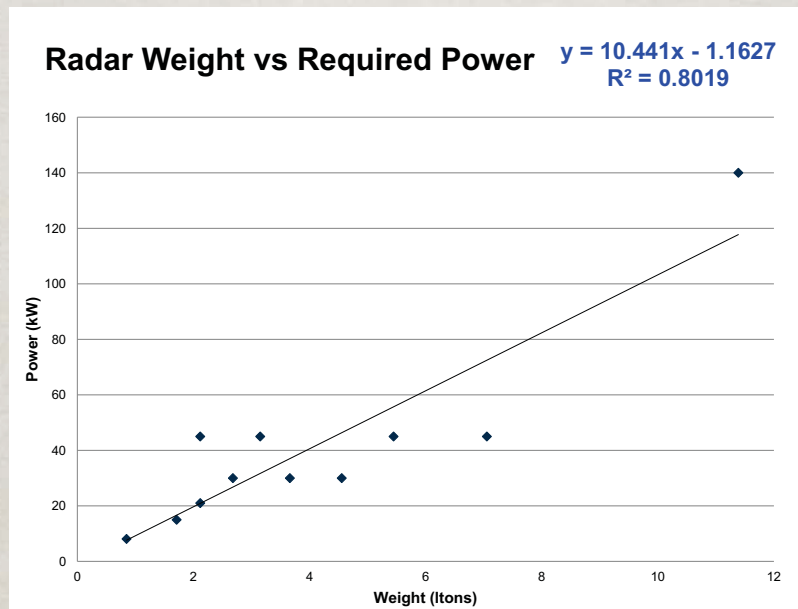

9

$$\text{Radar Range} = 37.255(\text{Radar Weight}) - 7.6297$$

$$\text{Radar Power} = 10.441(\text{Radar Weight}) - 1.1627$$



Revision to Input Worksheet

	A	B	C	D	E	F
1	Description	Variable	Value	Units	Input/Calc /Constant	Equation/Source
41	Deckhouse Material Coefficient	CDHMAT	2		Calc	Deckhouse Material: Aluminum, CDHMAT=1; Steel, CDHMAT=2
42	CPS Type	CPS	None		Input Here	Full, Partial, None
43						
44	Payload					
45	Payload Weight	W _P	579.56	lton	Calc	From Payload Sheet
46	Payload VCG	VCG _P	24.67	ft		From Payload Sheet
47	Variable Payload Weight	W _{VP}	199.47	lton		From Payload Sheet
48	Variable Payload VCG	VCG _{VP}	25.66	ft		From Payload Sheet
49	Stores Period	TS	30	days	Input Here	
50	Command and Surveillance (W400 less 420 and 430)	WP400	223.98	lton	Input Here	From Payload Sheet
51	Mission Handling/Support (W500)	WP500	39.46	lton	Input Here	From Payload Sheet
52	Mission Outfit (W600)	WP600	7.74	lton	Input Here	From Payload Sheet
53	Armament (W700)	WT7	93.65	lton	Input Here	From Payload Sheet
54	Ordinance (WF20)	WF20	135.67	lton	Input Here	Payload Sheet (including helo wt, WF23)
55	Number Helicopters	NHELO	0		Input Here	Payload Sheet
56	Helo Weight (WF23)	WF23	0	lton	Input Here	Payload Sheet
57	Helo Fuel (WF42)	WF42	63.8	lton	Input Here	Payload Sheet
58	Sonar Dome Water	WT498	0	lton	Input Here	Payload Sheet
59	Sonar Dome Water VCG	VCG498	0	ft	Input Here	Payload Sheet
60	Desired Radar Detection Range	R _D	400	km	Input Here	
61						
62	Manning					
63	Officers	N _O	39	people	Input Here	
64	Enlisted (including CPO)	N _E	255	people	Input Here	



Combat Systems Equations Worksheet

	A	B	C	D	E	F	G	H
1								
2		Radar Weight Equation						
3	R _W	10.94161052						
4								
5								
6		Radar Power Equation						
7	R _{PW}	123.8075264						
8								
9								
10								
11								
12								
13								
14								
15								



Revision to Combat System Worksheet

Microsoft Excel - Surface Combatant Model Gill_thesis_High Det_Range [Compatibility Mode]

	A	B	C	D	E	F	G	H	I
	PAYLOAD NAME	WT KEY	WT	VCG DATUM	VCG FT AD	AREA KEY	HULL FT2	DKHS FT2	CRUISE KW
3	STEEL LANDING PAD [ON HULL] - Helicopter CAPABLE	W111	10.7	30.5	0.20	NONE	0	0	0
4	32 CELL VLS ARMOR	W164	14	38.31575	-10	NONE	0	0	0
5	GUN ARMOR	W164	9	39.5	-8.00	NONE	0	0	0
6	5M BOW SONAR DOME W/MINE AVOIDANCE	W165	85.7	0	-1.5		0	0	0
7	GROUP 100	WP100	119.4				0	0	0
9	CIC W/ command and control computer system & 2X Large screen displays	W410	19.34	0	35.58	A1131	1953	448	45.03
10	NAVIGATION SYSTEM	W420	7.29	51	14.00	A1132	0	848.3	55.99
11	ADV DIGITAL C4I (JTIDS, LINK 16/LINK 22/TADIXS/TACINTEL)	W440	37.91	51	-46.84	A1110	1230.6	1270.4	35.76
12	multifunction SURFACE SEARCH RADAR	W456	40	51	-10.00	A1121	0	70	8
13	AIR SEARCH RADAR	W452	10.94	51	-7.1	A1121	0	553	15.3
14	IFF	W455	2.32	51	-5.00	NONE	0	0	3.2
15	X-BAND RADAR AND FOUNDATION, 110 FT ABOVE BL	W456	4.11	0	113.00	NONE	0	0	220.16
16	5M BOW SONAR DOME ELEX W/MINE AVOIDANCE	W463	57.7	0	9.3	A1122	1942	0	39
17	BATHY THERMOGRAPH	W465	0.31	30.5	-10.90	A1122	85.5	0	0
18	SONOBUOY PROCESSING SYSTEM	W466	5.26	51	-44.86	NONE	0	0	1.15
19	Electronic Warfare System w/ ACTIVE ECM	W472	4.4	33.4	20.60	NONE	0	0	6.4
20	Electro-Acoustic Decoy (NIXIE)	W473	0.24	30.5	-6.20	A1142	200	0	3
21	Decoy Launching System W/6 LAUNCHERS	W474	0.96	33.4	5.39	NONE	0	0	2.4
22	5"/54 Gun Fire Control System	W481	7.50	51	-4.00	A1212	0	168	6
23	Missile Fire Control System - STIR/CORT/IADT/CEC	W482	6.29	51	-1.40	NONE	0	0	50.3
24	VLS WEAPON CONTROL SYSTEM	W482	0.7	35.0585	2.54	A1220	56	310	13.62
25	ADVANCED long range cruise missile WEAPON CONTROL SYSTEM	W482	5.6	33.4	-7.80	NONE	0	0	13.27
26	ASW CONTROL SYSTEM [ASWCS] W/SSD	W483	3.75	33.4	-12.60	A1240	320	0	8.61
27	COMBAT DF	W495	8.26	33.4	21.00	A1141	0	448	15.47
28	ELECTRONIC TEST & CHECKOUT	W499	1.1	38.31575	10.80	NONE	0	0	0
29	GROUP 400	WP400	223.98				5787.1	4115.7	542.66
31	32-CELL VLS MAGAZINE DEWATERING SYSTEM	W529	3.5	35.0585	-0.46	NONE	0	0	0
32	AVIATION FUEL SYS	W542	4.86	35.0585	-11.00	A1380	30	0	2

10:26 AM 9/19/2011



AAW Scenario

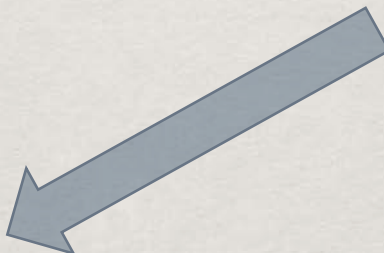

Measure of Effectiveness (MOE)

UNTL Naval Tactical Task 6 "Protect the Force" – M1 Casualties to friendly forces due to enemy actions

$$P_{\text{Being Killed}} = \frac{\text{Number of Times the Ship is Hit}}{\text{Number of Simulation Runs}}$$

$$P_{\text{Survival}} = 1 - P_{\text{Being Killed}}$$

MOE for this Scenario is P_{Survival}

Operational Model in ExtendSim

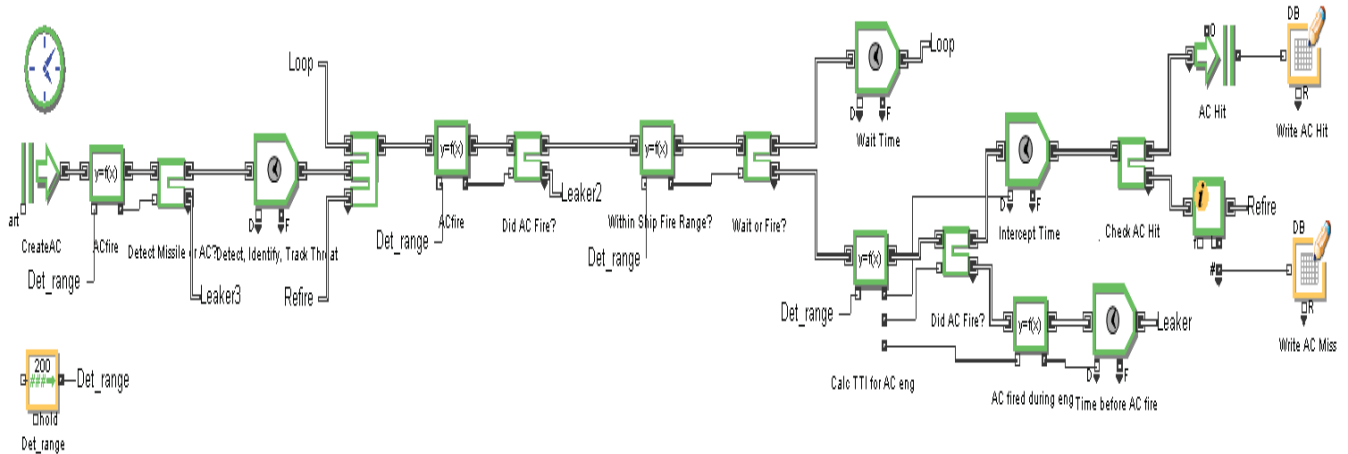



Operational Model in ExtendSim

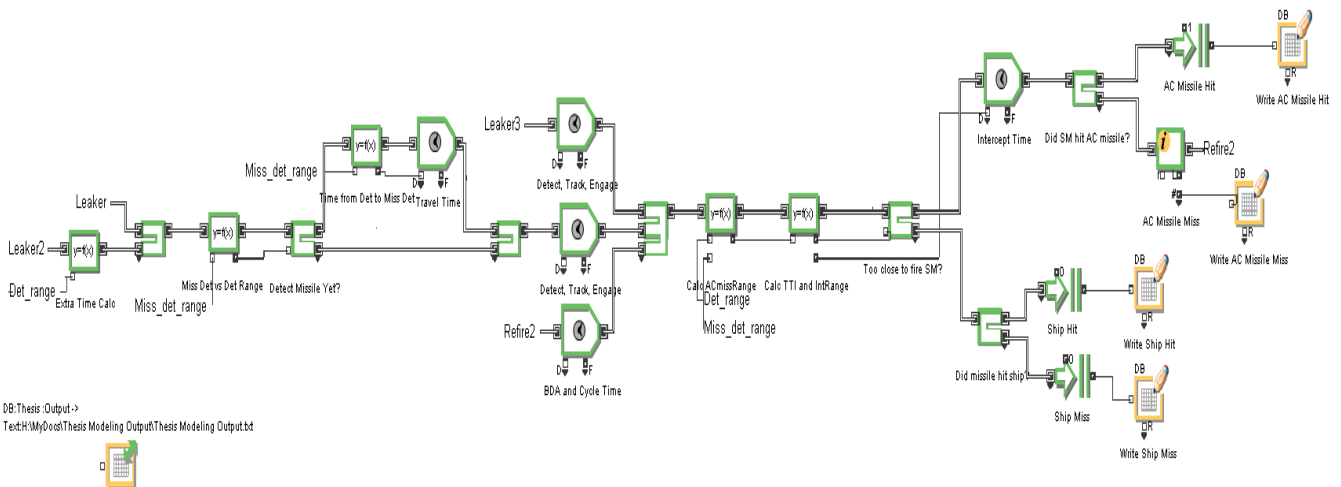

Operational Model in ExtendSim

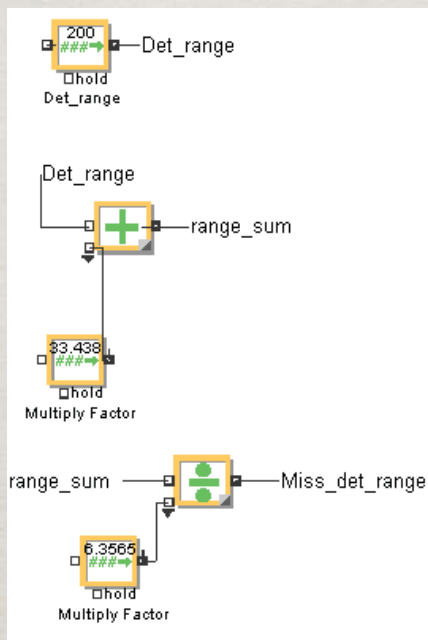



Operational Model

Constant Parameters	Value
Maximum Aircraft Firing Range	100 km (54 nm)
Maximum Ship Firing Range	150 km (81 nm)
Minimum Ship Firing Range	2 km (1.08 nm)
Aircraft Velocity	0.3087 km/s (0.9M)
SAM Velocity	0.8575 km/s (2.5M)
ASM Velocity	0.686 km/s (2M)
SAM P_K of Aircraft	0.65
SAM P_K of ASM	0.6
ASM P_K of Ship	0.85

Ultimate Outcomes of Operational Model

- A/C hit, ship not hit
- ASM hit, ship not hit
- ASM hit, ship hit
- Neither ship nor ASM hit

Model Assumptions

- Ship is stationary
- Ship at highest level of combat readiness
- Shoot-Look-Shoot Doctrine for ship
- A/C's tactics: shoot 1 ASM when it reaches its firing range, change course, return to home base
- A/C's radar detection range > A/C's firing range
- If the ship or aircraft is hit, $P_S = 0$
- $P_{\text{Detection}}$ of ship and aircraft's radar is equal to 1
- All environmental and time factors (weather, sea state, visibility, temperature, etc.) are ideal for ship and aircraft combat system and weapon performance



Results of Operational Model

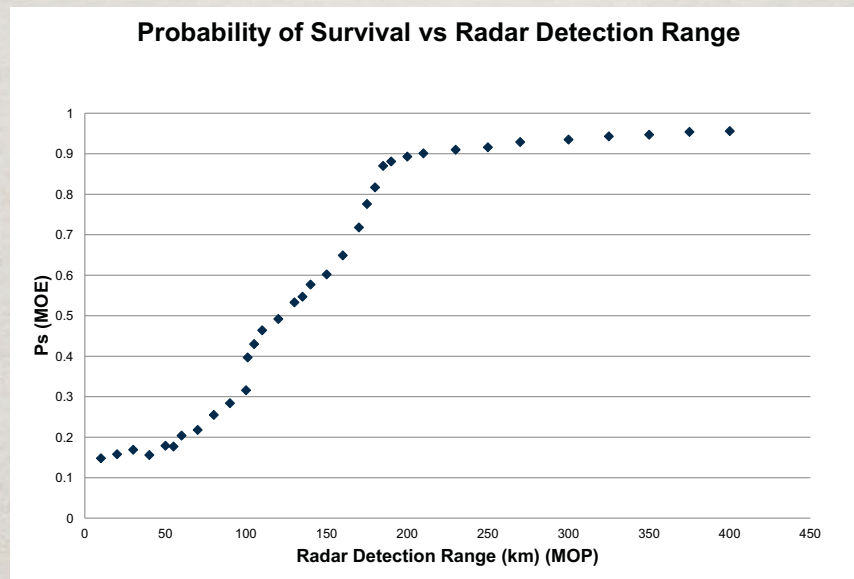

Sachsen Class (Type 124) FFGHM



- 5600 LT
- SMART-L Radar
- 32 Cell VLS (SM-2 Blk III A)

Principal Characteristics		Weight Summary	
LWL	413.0ft	Description	Weight (tton)
Beam	53.0ft	Group 1	1651.0
Depth, Station 10	36.0ft	Group 2	381.9
Draft	15.1ft	Group 3	178.6
GMT	5.1ft	Group 4	281.9
GM/B Ratio	0.095	Group 5	651.1
CP	0.6	Group 6	495.3
CX	0.85	Group 7	93.7
		Sum 1 - 7	3725.5
Sustained Speed	29.0knt	Design Margin	373.3
Endurance Speed	18.0knt	Lightship Weight	4106.5
Endurance	4000nm	Loads	720.2
		Full Load Weight	4826.7
Number Main Engines	3	Full Load KG	21.20ft
Main Engine Rating	17000hp		
		Military Payload	572.5tton
SHP/Shaft	25500hp	Payload Fraction	0.12
Propeller Type	CRP	Fuel Weight	391.5tton
Propeller Diameter	15.0ft		
		Manning	
Number SSGTG	4	Officers	39
SSGTG Rating	1000kW	Enlisted (Including NCO)	255
Maximum Margined Electrical Load	3102kW	Total	294
	Area Summary		Volume Summary
Hull Area	38780ft ²	Hull Volume	349024ft ³
Superstructure Area	22222ft ²	Superstructure Volume	200000ft ³
Total Area	61003ft ²	Total Volume	549024ft ³

Ship Synthesis Results		
Air Search Radar Range	Total Ship Full Load Weight	Ship Survivability in AAW
High (400 km)	4840 Itons	96%
Med (135 km)	4826.7 Itons	55%
Low (55 km)	4822.7 Itons	18%

- Found quantitative relationship between radar detection range and radar weight
- Link between Combat System (CS) Design Parameter and Naval Architecture Parameter that can be coupled to operational simulation model to determine warfighting MOE
- Showed variability in the CS architecture characteristics based on CS parameter inputs
- Enhanced ability to evaluate a CS parameter based on its impacts on ship's naval architecture and warfighting effectiveness
- Improves decision making process



- Examine any or all of the ship's combat systems and warfighting effectiveness measures in all warfare areas
- Improved fidelity of the models
- Develop accurate cost models for changes in combat systems



QUESTIONS?



NAVAL
POSTGRADUATE
SCHOOL

A Hybrid Approach to Tactical Vehicles

Thesis by
Mark D. Fingerholz
September, 2011

Monterey, California
WWW.NPS.EDU



Agenda

- Background
- Purpose
- Research Questions
- Scope of Study
- Concepts
- Capability Comparison
- Impact Analysis
- Concept Selection
- Recommendations
- Further Research

“Unleash Us from the Tether of Fuel.”

General James T. Mattis, 2003
Commanding General
1st Marine Division
Operation Iraqi Freedom

3

Background – Risk Reduction



4 58

Background – Fuel Economy

**Urban Assault
 MPG
 9.2**

**Convoy Escort
 MPG
 13.4**

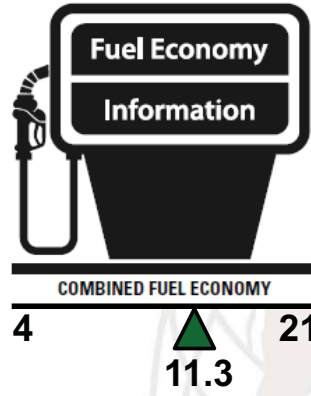

**Tactical Idle
 (Gallons/hour)
 0.62**

Fuel Delivery Method Matters!

Garrison

Deployed

\$2.82 / gal

\$13 - \$600 / gal

≈ \$8k / vehicle

≈ \$36k – \$1.7M / vehicle

≈ \$1.9B / fleet

≈ \$9B – \$418B / fleet

- Describe current suite of hybrid drivetrain technologies
 - Evaluate their effectiveness in a tactical environment
- Recommend a hybrid drivetrain architecture
 - Reduces fuel consumption
 - Maintains performance against requirements
 - Mobility
 - Transportability
 - Survivability
 - Safety

- 1) What elements of a vehicle's architecture have the greatest impact on fuel efficiency of a vehicle?
- 2) What hybrid vehicle drivetrains exist?
- 3) How do the hybrid drivetrains perform against vehicle mobility, transportability, survivability, and safety requirements?
- 4) What hybrid drivetrain architecture provides the best overall performance for tactical vehicles?

- Identify other vehicle architectures and characteristics that affect fuel efficiency
- Focus on current and developmental hybrid drivetrain vehicle technologies and their application to tactical vehicles
- Evaluate the concepts based on the following characteristics:
 - Power to weight ratios (specific power)
 - Energy storage (specific energy)
 - Energy conversion efficiency
 - Cycle life
 - Impacts on requirements
 - Mobility
 - Transportability
 - Survivability
 - Safety

- Vehicle Weight
- Engine Efficiency
- Engine Idling
- Vehicle Accessories
- Driveline
- Aerodynamic Drag
- Tire Rolling Resistance

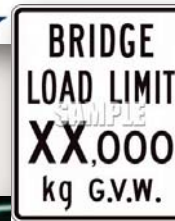
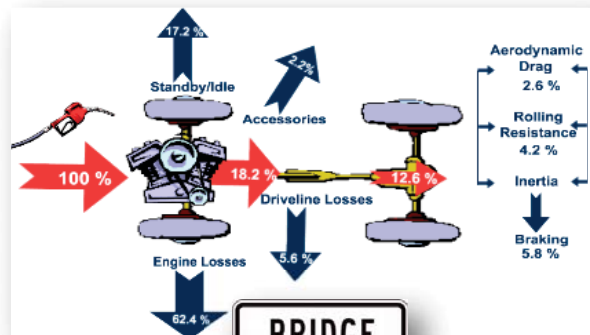

Parallel Hybrid

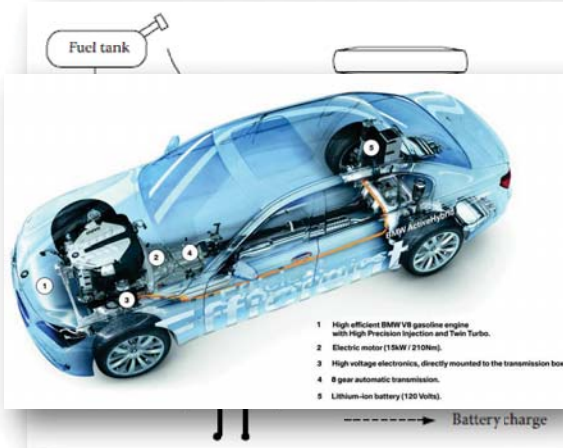

Series Hybrid

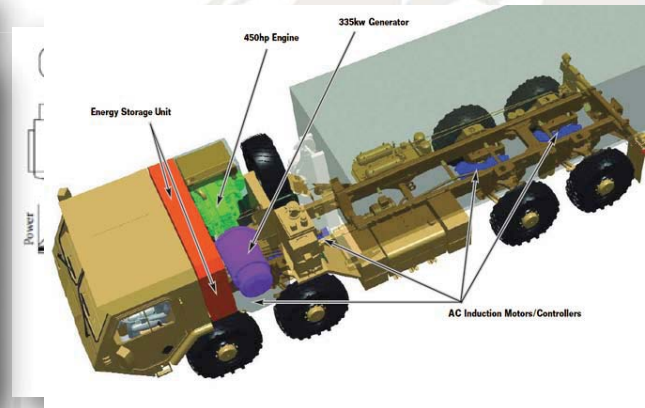

Mild Hybrid

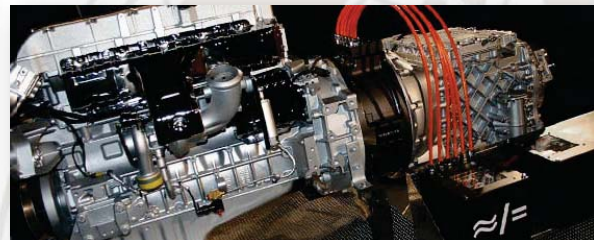
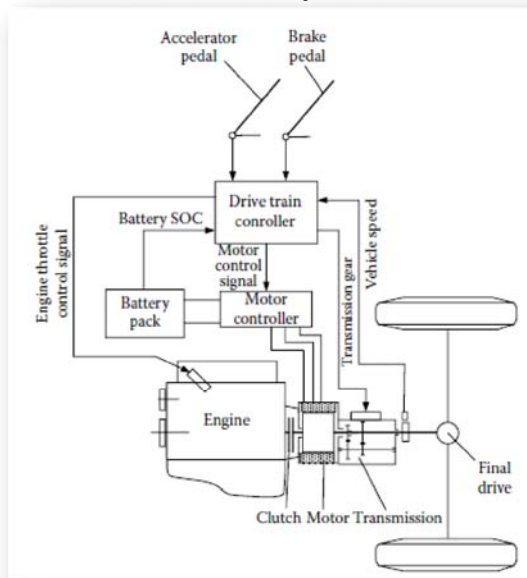

Power Source Combinations

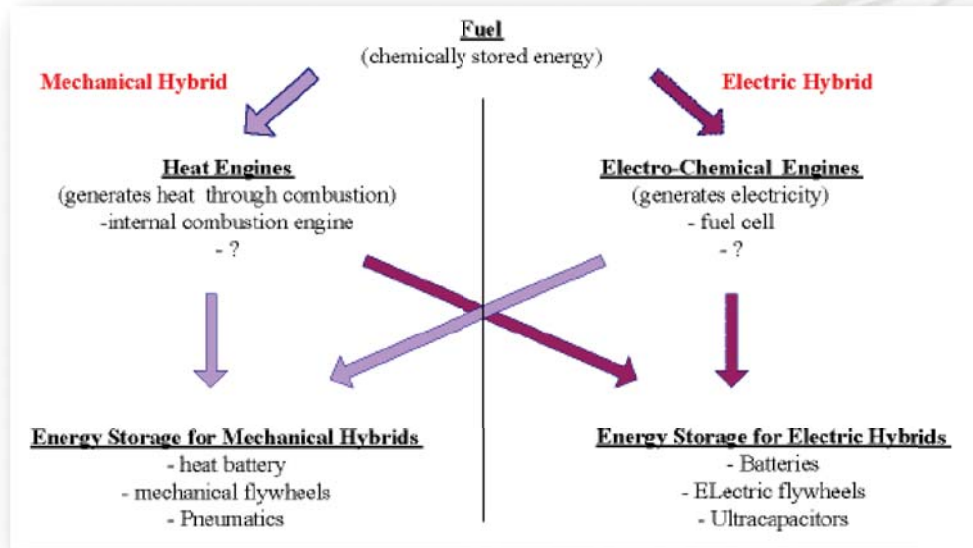

Internal Combustion Engine

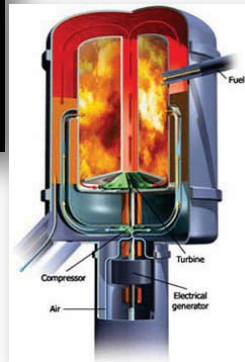

Microturbine

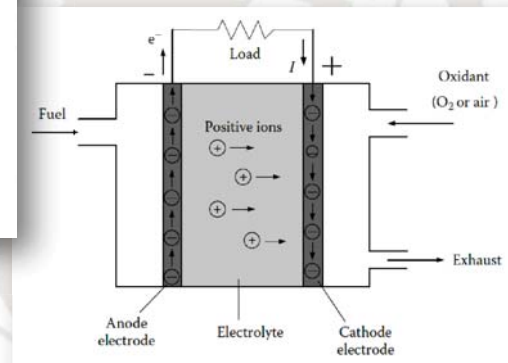

Fuel Cell



Battery Pack



Ultracapacitor

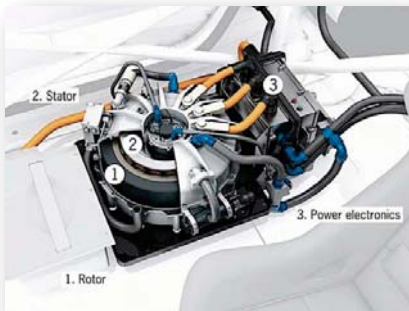

Electric Flywheel

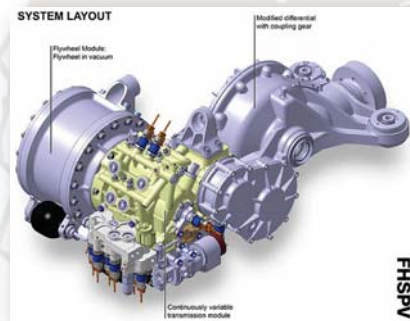

Mechanical Flywheel

15

- Specific Power (Power-to-weight Ratio)
- Specific Energy (Operating Range)
- Energy Conversion Efficiency
- Cycle Life
- Cost Analysis
 - Hybridization
 - Specific Cost
 - Fully Burdened Cost of Fuel (FBCF)



Capability Comparison

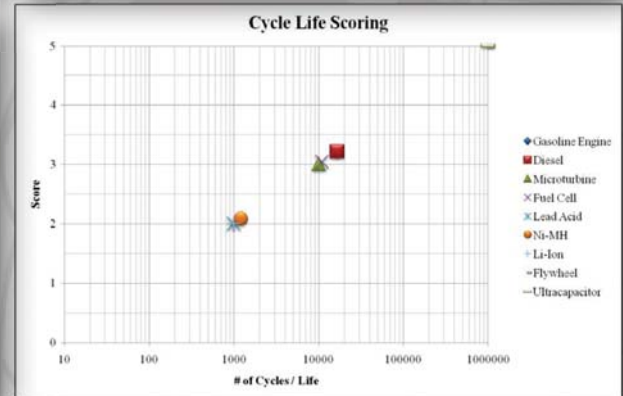
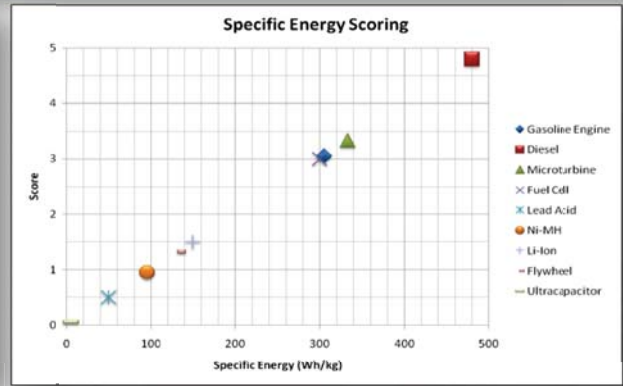
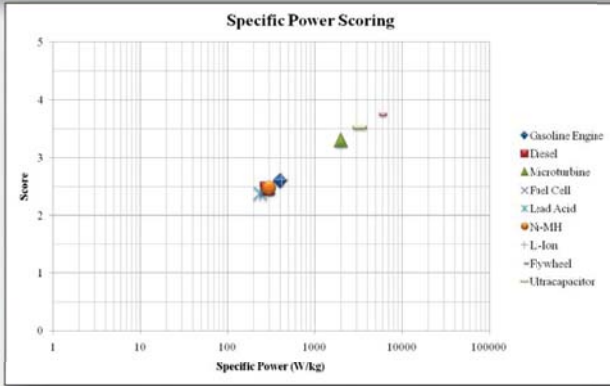

Cost Analysis – Hybridization

Conventional vs. Hybrid Vehicle Costs

Vehicle Category	Compact	Mid Size	Full Size	SUV	Full Size Pickup
Vehicle	Honda Civic	Nissan Altima	Infiniti M	Toyota Highlander	Chevrolet Silverado
Conventional Drivetrain (\$)	20,505	21,840	47,050	36,110	39,010
Hybrid Drivetrain (\$)	23,950	26,800	53,700	38,950	45,055
Hybrid Price Effect (\$)	3,445	4,960	6,650	2,840	6,045
Hybrid Price Increase (%)	16.8	22.7	14.1	7.9	15.5

Average ≈ +15.4%

Power Source	Primary Power Sources				Secondary Power Sources				
	Gasoline Engine	Diesel Engine	Micro-turbine	Fuel Cell	Lead Acid Battery	Ni-MH Battery	Li-Ion Battery	Flywheel	Ultra-capacitor
Power Specific Cost (\$/kW)	19	28	750 - 1,100	19 - 48	80	75	75	200 - 500	12
Energy Specific Cost (\$/kWh)	-	-	-	-	120 - 150	200 - 350	200	690 - 800	16,000

Estimated Annual Fuel Consumption

	Mission Length (days)	Missions / Year	Miles/ Mission	Idle Hours/ Mission	Total Dynamic Operations (miles)	Total Static Operations (Idle-hours)	Est. Avg. mpg	Est. Avg. Gal/Hr	Total Fuel Used / year (gallons)
Major Combat	3	27	236	50.6	6,369	1,366	11.3	0.62	1,410
Irregular Warfare	7	17	253	86	4,310	1,462			1,288
Peacetime	-	-	-	-	1,500	-			133
Total	-	44	-	-	12,179	2,828	-	-	2,831

Estimated Annual Savings – Assuming 20% Improvement in Fuel Economy

Delivery Method	Retail (Stateside)	Ground (Deployed - Peacetime)	Ground (Deployed - Hostile Area)	Helicopter (In theater)
Cost (\$) / Gallon	2.82	13	100 - 600	400
Gallons Saved / Vehicle / Year	566			
Savings (\$) / Vehicle	1,596	7,358	56,600 - 339,600	226,400
Tactical Wheel Vehicles	246,000			
Total Annual Savings (\$ billions)	0.393	1.81	13.92 - 83.54	55.69

21

WWW.NPS.EDU

- Transportability
- Safety
- Complexity
- Mobility
- Survivability

22 **67**

WWW.NPS.EDU

Scoring Matrix – Energy State

		Fuel Energy Based (Reference)		Electric Energy Based		Mechanical Energy Based	
Selection Criteria	Weight	Rating	Weighted Score	Rating	Weighted Score	Rating	Weighted Score
Transportability	10%						
Land Transport	3.33%	3.00	0.10	3.00	0.10	3.00	0.10
Sea Transport	3.33%	3.00	0.10	2.00	0.07	3.00	0.10
Air Transport	3.33%	3.00	0.10	2.00	0.07	2.00	0.07
Safety	10%						
Electrical Shock	2.50%	3.00	0.08	2.00	0.05	3.00	0.08
Special Training	2.50%	3.00	0.08	2.00	0.05	2.00	0.05
Stowed Ammo	2.50%	3.00	0.08	2.00	0.05	3.00	0.08
Containment	2.50%	3.00	0.08	2.00	0.05	3.00	0.08
Net Score		0.53		0.38		0.47	
Rank		1st		3rd		2nd	

Scoring Matrix – Hybrid Architecture

		Conventional Drivetrain (Reference)		Series Hybrid		Parallel Hybrid		Mild Hybrid	
Selection Criteria	Weight	Rating	Weighted Score	Rating	Weighted Score	Rating	Weighted Score	Rating	Weighted Score
Complexity (# of components)	5%	3.00	0.15	2.00	0.1	1.00	0.05	2.00	0.10
Mobility	10%								
Tractive Effort	1.67%	3.00	0.05	5.00	0.08	4.00	0.07	4.00	0.07
Handling	1.67%	3.00	0.05	4.00	0.07	4.00	0.07	4.00	0.07
Steering	1.67%	3.00	0.05	4.00	0.07	3.00	0.05	3.00	0.05
Acceleration	1.67%	3.00	0.05	4.00	0.07	4.00	0.07	4.00	0.07
Braking	1.67%	3.00	0.05	2.00	0.03	3.00	0.05	3.00	0.05
Longitudinal Grade	1.67%	3.00	0.05	4.00	0.07	3.00	0.05	4.00	0.07
Survivability	5%								
Visual Signature	0.83%	3.00	0.03	4.00	0.03	3.00	0.03	3.00	0.03
Infrared Signature	0.83%	3.00	0.03	4.00	0.03	4.00	0.03	3.00	0.03
Acoustic Signature	0.83%	3.00	0.03	4.00	0.03	4.00	0.03	3.00	0.03
Magnetic Signature	0.83%	3.00	0.03	2.00	0.02	3.00	0.03	3.00	0.03
Threat Protection	0.83%	3.00	0.03	4.00	0.03	4.00	0.03	4.00	0.03
Vulnerability	0.83%	3.00	0.03	5.00	0.04	4.00	0.03	4.00	0.03
Net Score		0.60		0.68		0.58		0.63	
Rank		3rd		1st		4th		2nd	



Scoring Matrix – Primary Power Source

		Gasoline Engine (Reference)		Diesel Engine		Microturbine		Fuel Cell	
Selection Criteria	Weight	Rating	Weighted Score	Rating	Weighted Score	Rating	Weighted Score	Rating	Weighted Score
Operating Range (Specific Energy)	20%	3.05	0.61	4.80	0.96	3.33	0.67	3.00	0.60
Power/Weight Ratio (Specific Power)	10%	2.60	0.26	2.46	0.25	3.30	0.33	2.48	0.25
Efficiency (%)	20%	1.50	0.30	2.25	0.45	1.30	0.26	2.40	0.48
Power Specific Cost (\$/kw)	5%	4.91	0.25	4.86	0.24	1.25	0.06	4.91	0.25
Transportability	10%	3.00	0.30	3.00	0.30	3.00	0.30	2.33	0.23
Safety	10%	3.00	0.30	3.00	0.30	2.75	0.28	2.00	0.20
Cycle Life	5%	3.22	0.16	3.22	0.16	3	0.15	3.04	0.15
Net Score		2.18		2.66		2.04		2.16	
Rank		2nd		1st		4th		3rd	



Scoring Matrix – Secondary Power Source

		Lead Acid Battery		Ni-MH Battery		Li-Ion Battery		Flywheel		Ultracapacitor	
Selection Criteria	Weight	Rating	Weighted Score	Rating	Weighted Score	Rating	Weighted Score	Rating	Weighted Score	Rating	Weighted Score
Operating Range (Specific Energy)	20%	0.50	0.10	0.95	0.19	1.50	0.30	1.32	0.26	0.05	0.01
Power/Weight Ratio (Specific Power)	10%	2.38	0.24	2.48	0.25	2.62	0.26	3.75	0.38	3.52	0.35
Efficiency (%)	20%	4.00	0.80	3.50	0.70	4.75	0.95	4.50	0.90	4.75	0.95
Power Specific Cost (\$/kw)	1.67%	4.60	0.08	4.63	0.08	4.63	0.08	4.00	0.07	4.94	0.08
Energy Specific Cost (\$/kwh)	3.33%	2.92	0.10	2.70	0.09	2.70	0.09	2.16	0.07	0.80	0.03
Transportability	10%	2.33	0.23	2.33	0.23	2.33	0.23	2.67	0.27	2.33	0.23
Safety	10%	2.00	0.20	2.00	0.20	2.00	0.20	2.75	0.28	2.00	0.20
Cycle Life	5%	2.00	0.10	2.08	0.10	2.00	0.10	5.00	0.25	5.00	0.25
Net Score		1.85		1.84		2.21		2.47		2.10	
Rank		4th		5th		2nd		1st		3rd	

- Hybrid Drivetrain Architecture Recommendation
 - *Hybrid Architecture*: Series
 - *Primary Power Source*: Diesel Engine
 - *Secondary Power Source*: Flywheel
 - *Traction Motors*: Permanent Magnet Motors

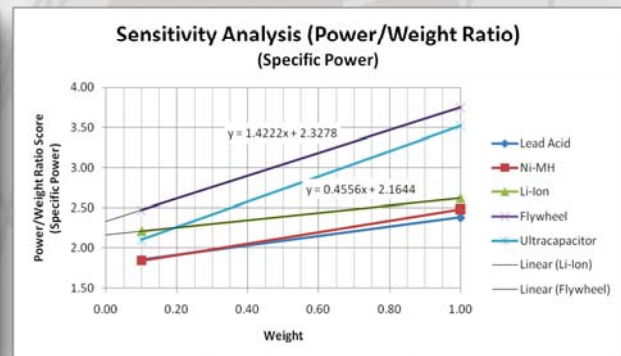
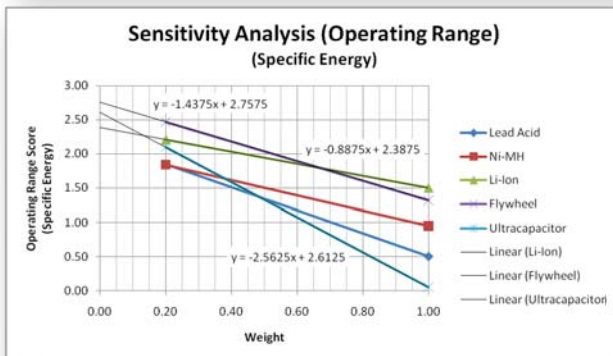
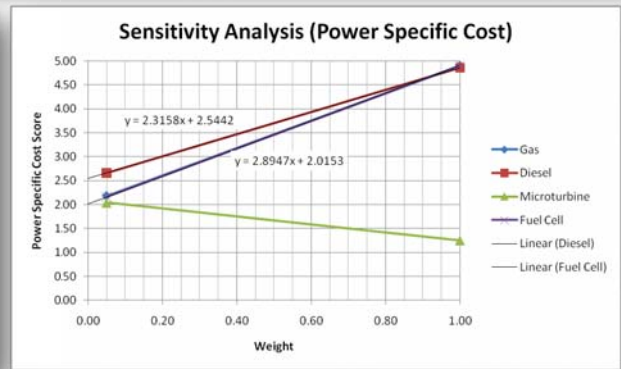
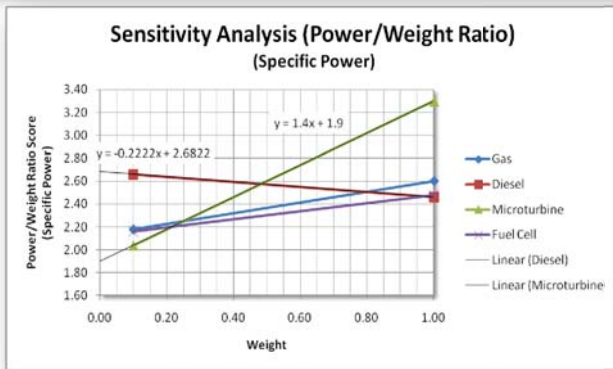

- Fuel efficiency improvements can be attained through attention to vehicle characteristics
 - In some situations, it may be more cost effective to focus on vehicle characteristics vs. hybridization
- Understand the Vehicle Duty Cycle
- Consider the dependencies of the selection criteria when developing the algorithm for the concept selection net score.
- Multiple Criterion Decision Theory
- Re-evaluate microturbines as their specific costs approach that of internal combustion engines



WWW.NPS.EDU

29

- Hydraulic Hybrids
- Export Power
 - Pulse Power Weapons
 - Electro-magnetic guns
 - Lasers
 - Microwave weapons
 - Active Armor Concepts



WWW.NPS.EDU

30 71



Backup Slides

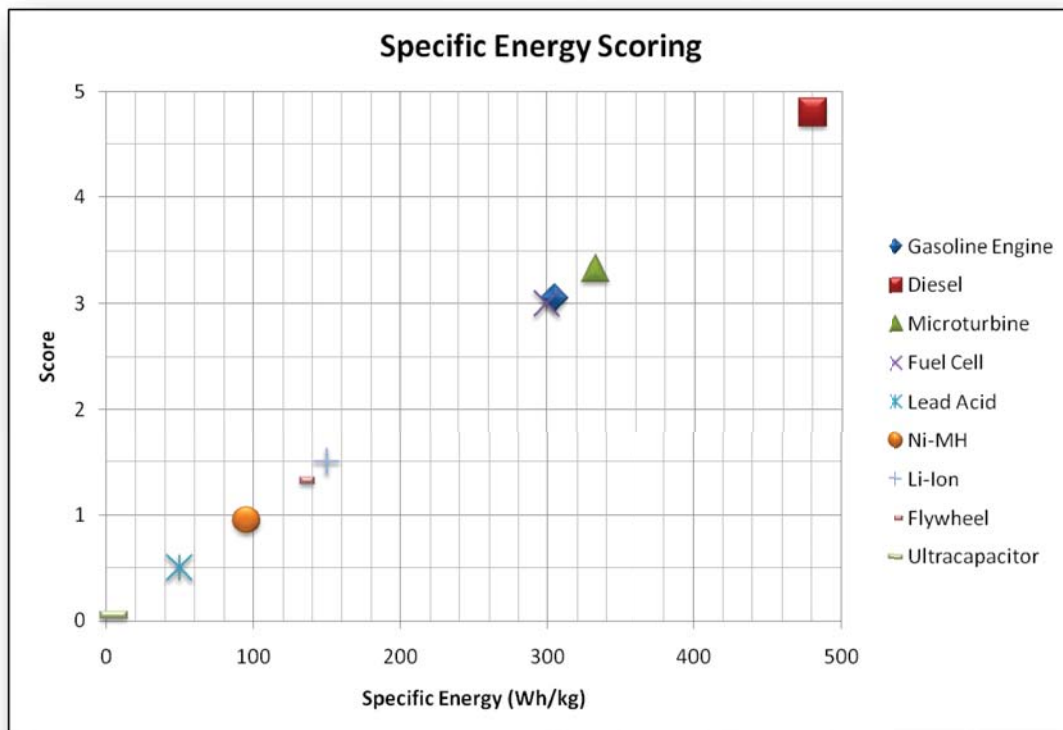
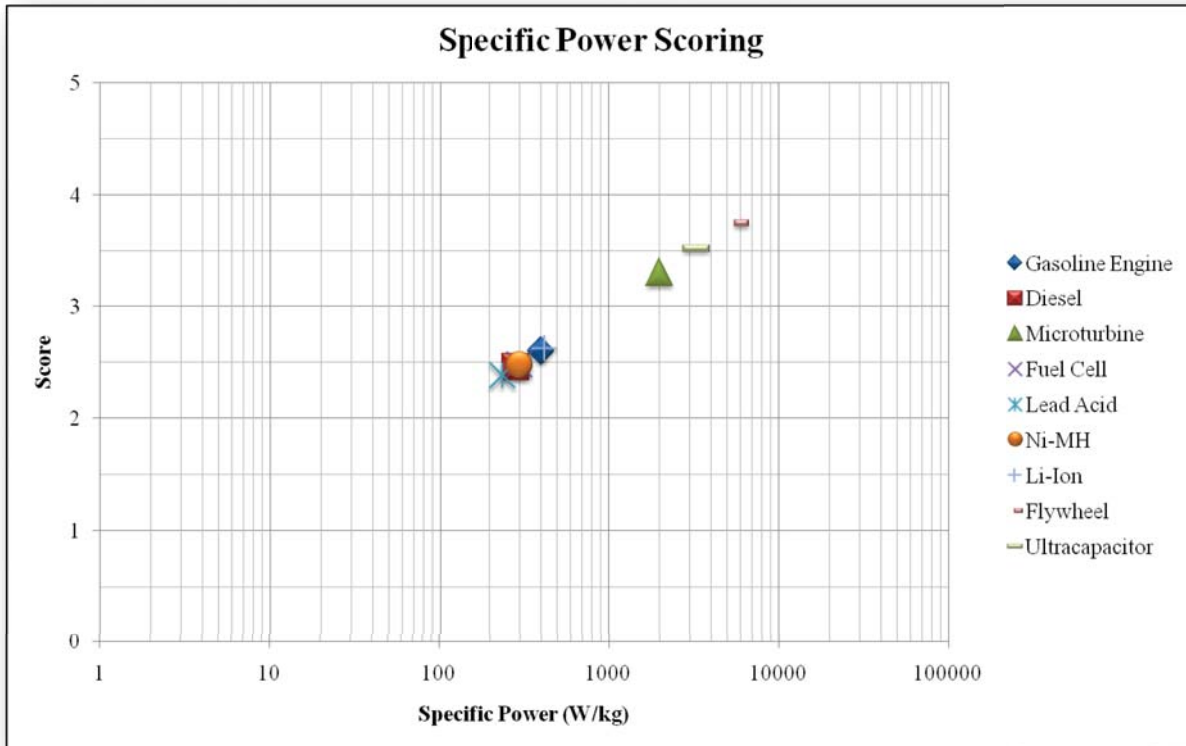

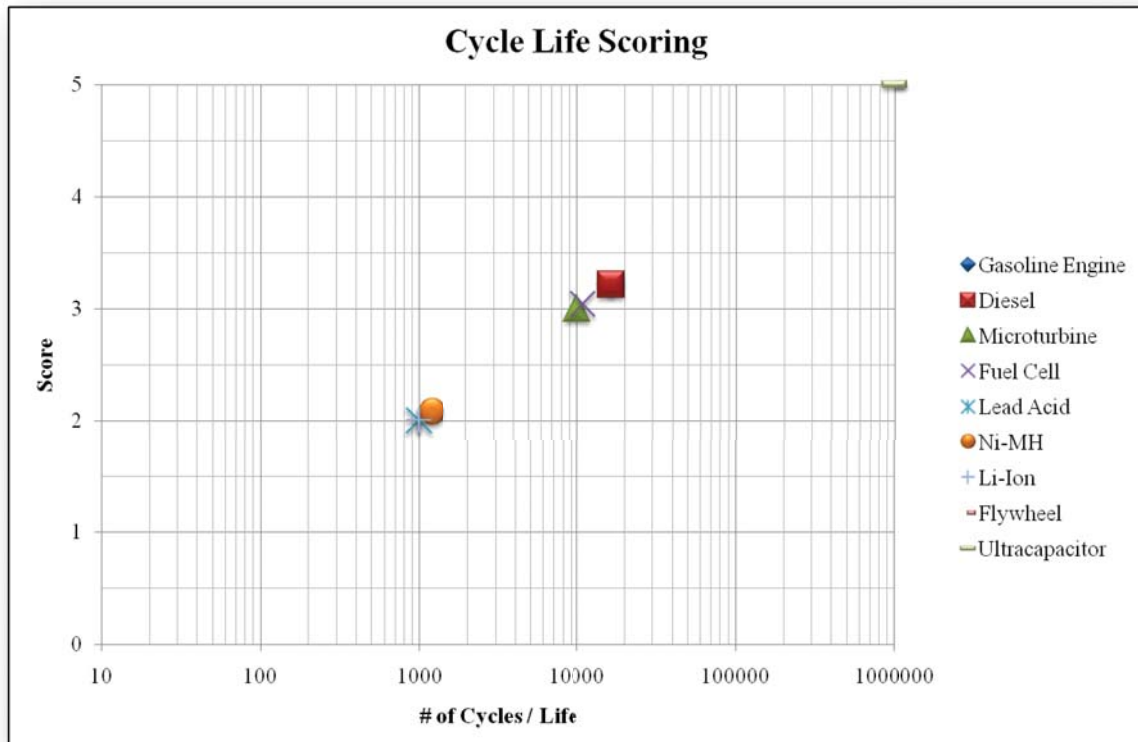
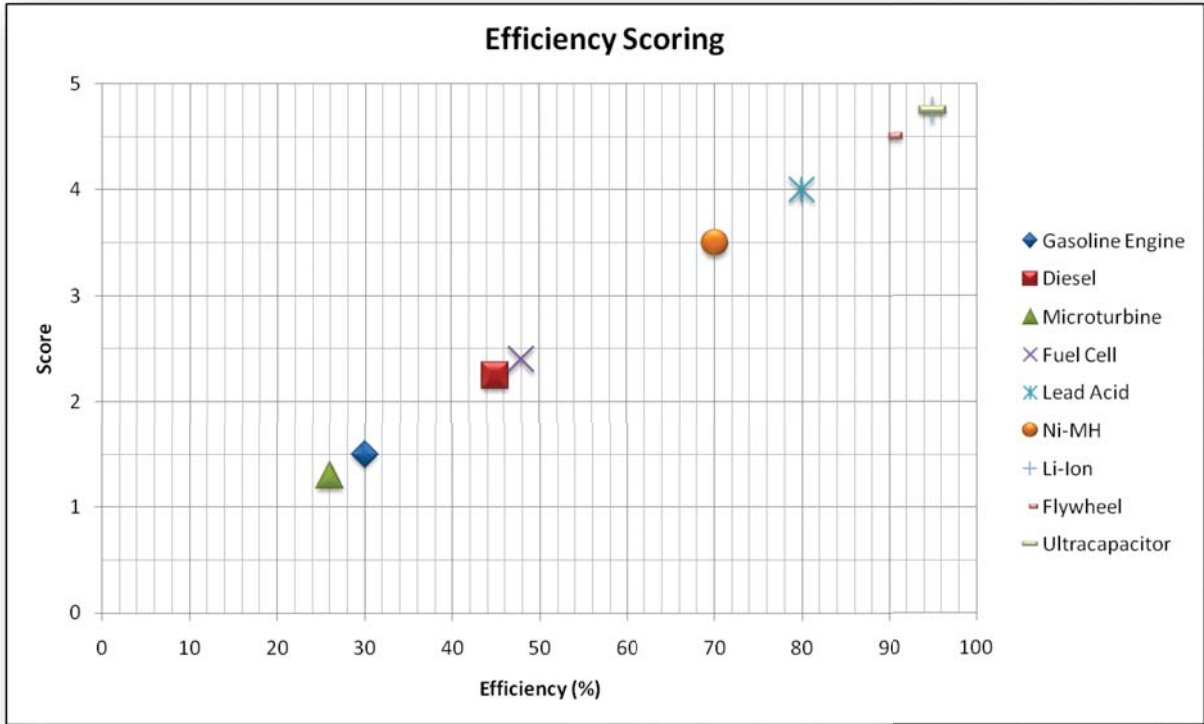



NAVAL
POSTGRADUATE
SCHOOL
MONTEREY, CALIFORNIA

A systems engineering trade-off analysis method to assess the value of alternatives that do not meet all requirements

by
Kenneth A. Bogdan
September 2011

Thesis Advisor: Paul Montgomery, D.Sc.
Thesis Co-Advisor: David Olwell, Ph.D.

BACKGROUND

In a Trade Study, both of these alternatives would be either eliminated or severely punished with low assessment scores for failing to meet all of the requirements.

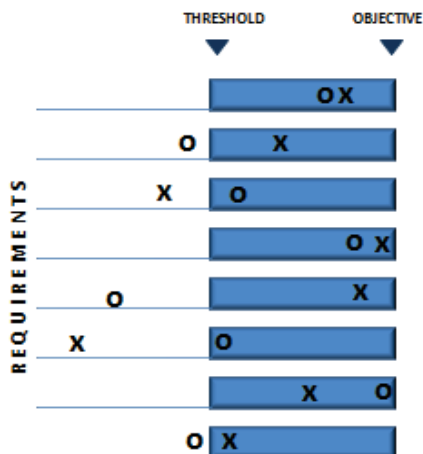

COTS and NDI products
often fall into this
situation.

PROBLEM STATEMENT

Current system engineering trade study approaches examine fixed alternatives

... but fail to take into consideration the opportunity and importance of improving the alternatives in an effort to make them viable.

OPPORTUNITY

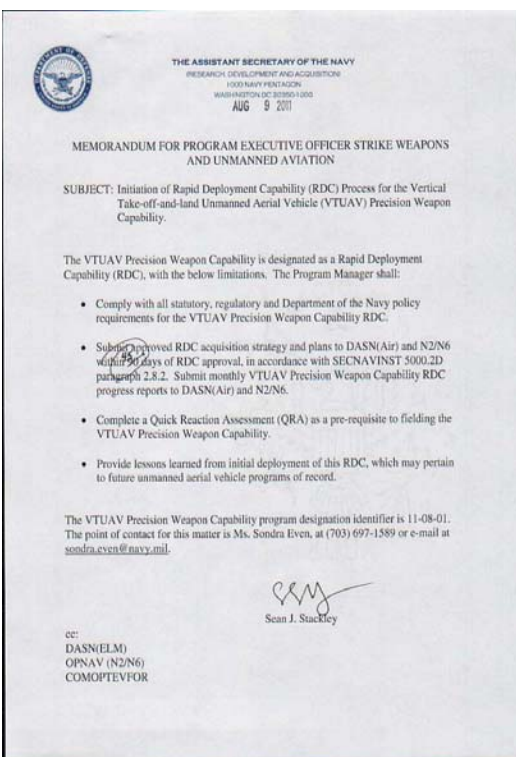

Memo to rapidly put
weapons on Fire
Scout VTUAV ...

DID I HEAR THAT RIGHT?

**ROBOT KILL-CHOPPER GOES ROGUE
above Washington DC!**

[The day the Fire Scout went rogue](#)

AUGUST 25TH, 2010 | [AVIATION WASHINGTON](#) | POSTED BY [PHIL EWING](#)



La la la, I'm not listening Mr Fleshy



"Y'know what? No, I am not going to zoom in on the fantail of that unidentified fishing vessel. I want to go see the Washington Monument!"
// Navy

*Actual news articles

STORES MANAGEMENT SYSTEM ARCHITECTURE

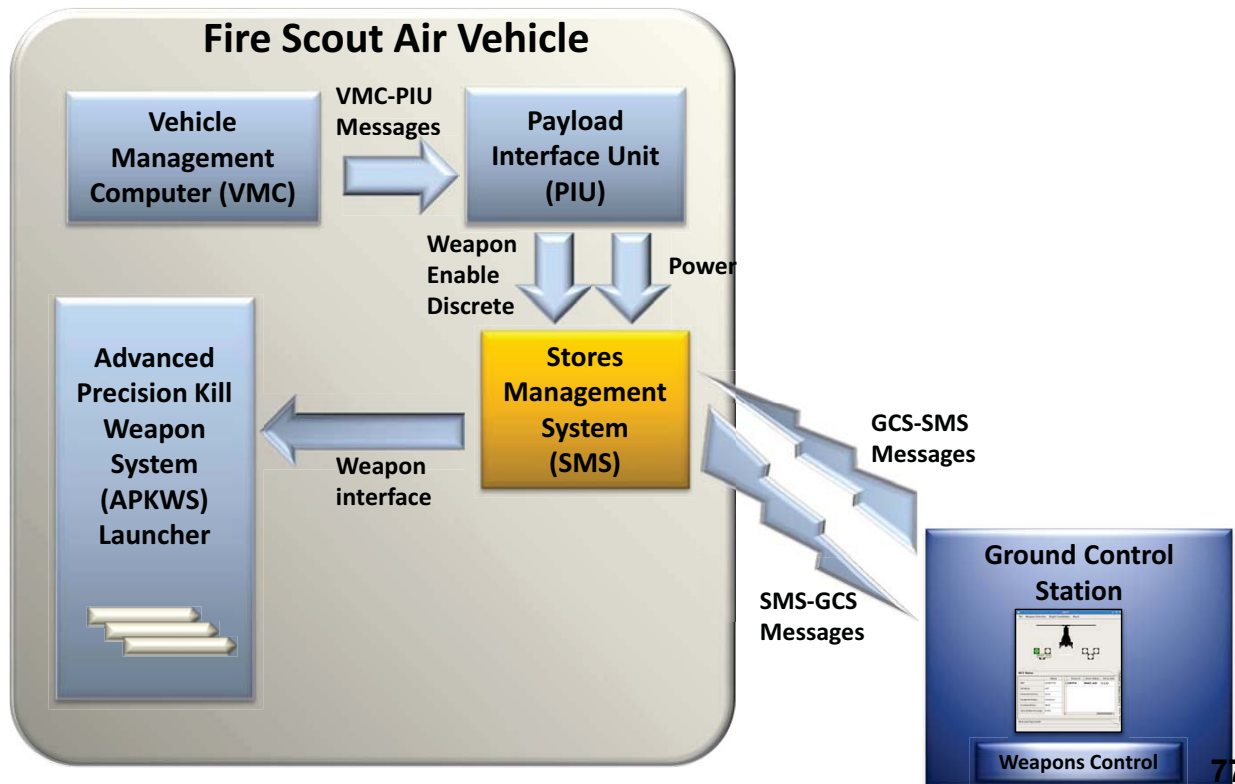

STORES MANAGEMENT SYSTEM ALTERNATIVES

Modifications to Existing Payload Interface Unit (PIU)

- Embeds the weapon control and management functionality within the existing PIU subsystem.

Integration of SMS 1

- Integrates an independent SMS into the existing MQ-8B system architecture.
- Developed by the SMS 1 vendor using internal funding as well as Small Business Innovation Research (SBIR) funding.
- Integrated into the MQ-8B system as part of the SBIR effort.

Integration of SMS 2

- Integrates an independent SMS into the existing MQ-8B system architecture.
- Developed a prototype SMS using both company internal funding and government congressional directed funding (earmarks).
- Evaluated by the Navy safety board and determined to have an adequate safety architecture.

RESEARCH QUESTIONS

- Can a trade-off analysis method be defined to assess the value of alternatives that do not meet all of the requirements?
- Can this method be applied to and increase the effectiveness of a trade study on the alternatives for a subsystem to control and manage weapons in the MQ-8B Fire Scout weaponization effort?
- What features of a tool to implement this method are beneficial to users?

INITIAL ASSESSMENT

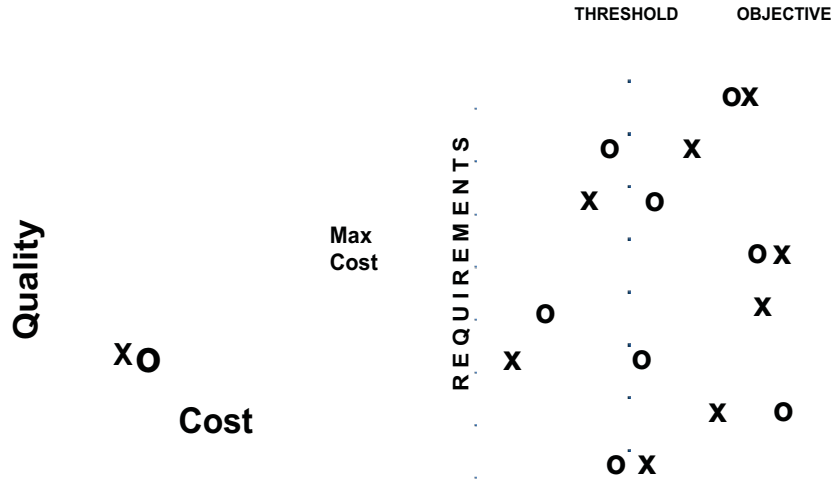

IMPROVED TO MEET THRESHOLD

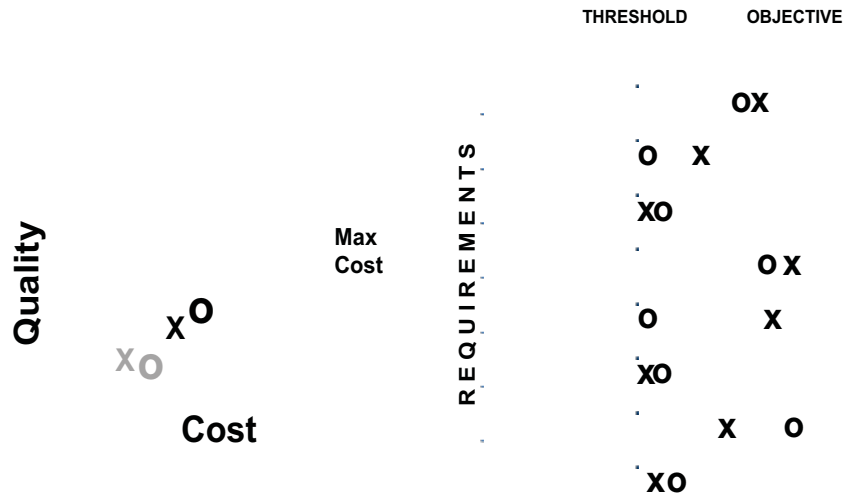

OPTIMIZED IMPROVEMENTS

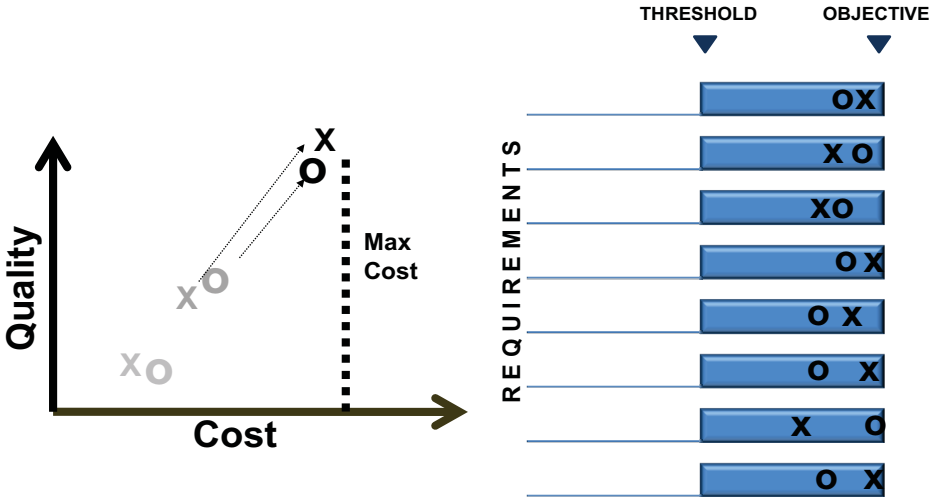

SE TRADE STUDY PROCESS FLOW

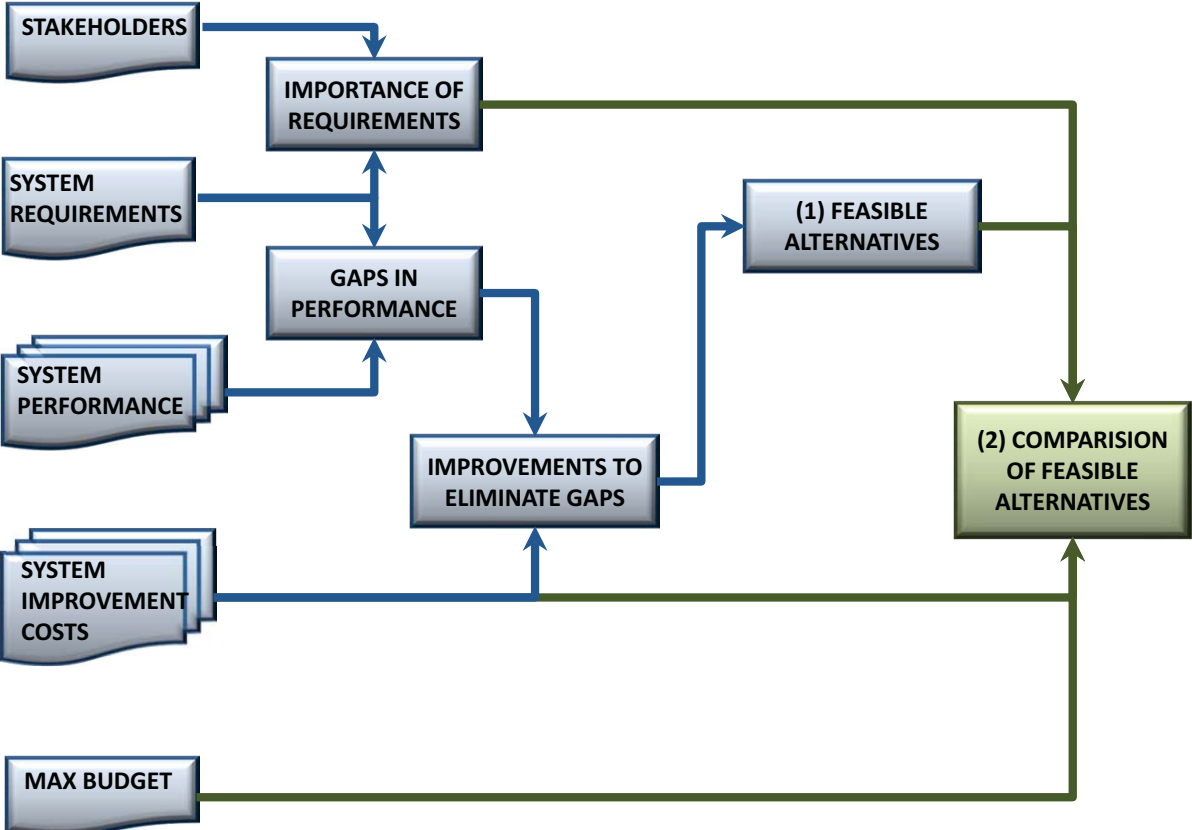

MODEL INPUT AND OUTPUT

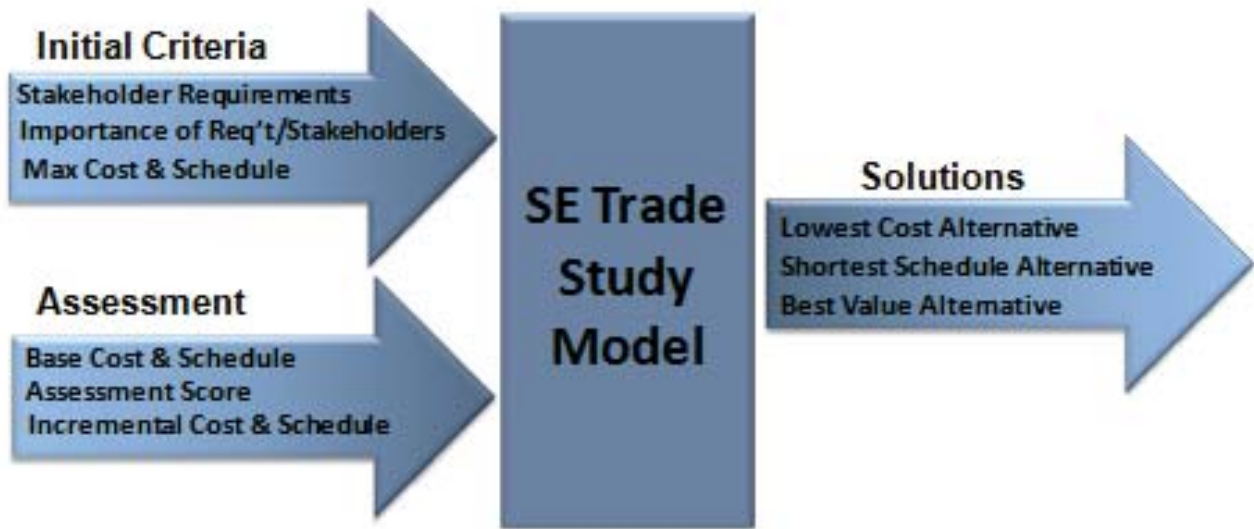

MODEL ARCHITECTURE

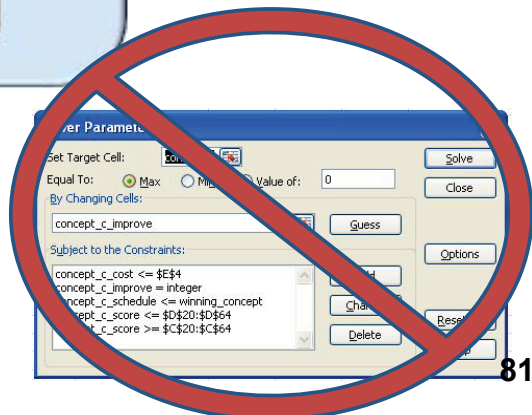
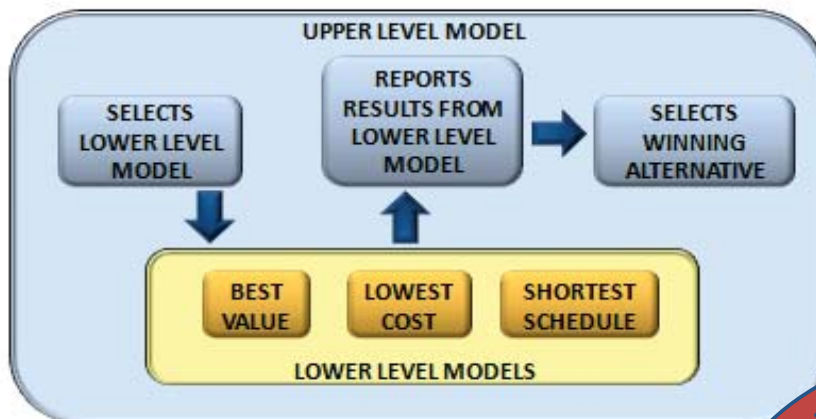

MODEL ALGORITHMS

$$\text{Best Value} = \text{Max} (Q_c / C_c)$$

$$\text{Lowest Cost} = \text{Min}(C_c)$$

$$\text{Shortest Schedule} = \text{Min}(S_c)$$

Where

$$Q_c = \sum_{s=1}^{s_{\max}} I_s \sum_{r=1}^{r_{\max}} (R_{cr} + D_{cr}) V_{sr}$$

$$C_c = B_c + \sum_{r=1}^{r_{\max}} D_{cr} E_{sr}$$

$$S_c = T_c + \sum_{r=1}^{r_{\max}} D_{cr} A_{cr}$$

MODEL ALGORITHMS

Subject to :

$$(R_{cr} + D_{cr}) \geq T_r$$

$$(R_{cr} + D_{cr}) \leq \text{maxscore}$$

$$C_c \leq \text{maxcost}$$

$$S_c \leq \text{maxsched}$$

$$D_{cr} \geq 0$$

$$D_{cr} = \text{integer}$$

ASSUMPTIONS & CONSTRAINTS

- The weapon is ADVANCED PRECISION KILL WEAPON SYSTEM with three per weapon station
- The Bomb Release Unit (BRU)-59 rack will be modified to support a three tube launcher at both weapon stations
- The SMS will be installed in Zone 6 of the MQ-8 electronic compartments.
- The Software Integration Laboratory (SIL) testing, aircraft ground testing, and flight testing will be the same for all alternatives. This “wash cost” is not part of the cost analysis.
- The effort to modify and integrate the SMS into the MQ-8 architecture must be completed within five months to meet the RDC schedule.

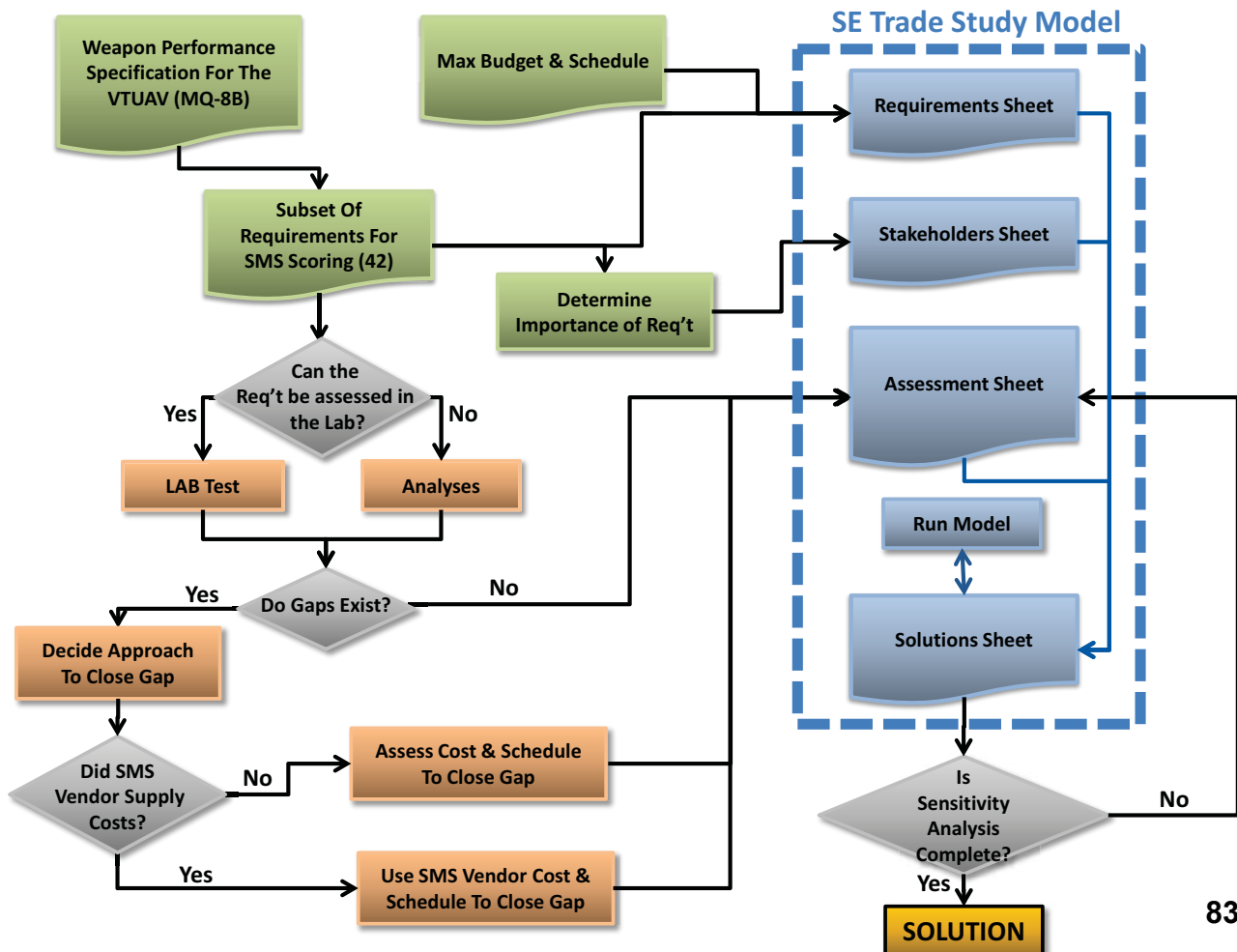

REQUIREMENTS SHEET

Budget and Schedule Requirements			
Maximum Budget (\$K)	\$40,000		
Maximum Schedule: (Weeks)	72		
Performance/Scope Requirements			
This Excel implementation supports only a limited number of requirements. Fill in the system requirements starting at requirement number 1 and don't exceed the size of the table below. Leave unused requirements blank.			
Requirement Number: Don't touch, leave sequential			
Threshold Rating: This is automatically filled in			
Requirement Number	Threshold Rating (Tr)	Max	Requirement Description
1	3	5	3.2.19.3.1 The weapon system shall be maintainable using tools and equipment within the USN current maintenance facilities and tool assets .
2	3	5	3.2.19.3.2.1.1 The Weapon System, upon power application, shall perform a Power-up BIT (PBIT).
3	3	5	3.2.19.3.2.1.1.1 The PBIT shall detect and report Weapon System failures/faults that would prevent the Weapon System from meeting its mission requirements and isolate faults to the WRA level.
4	3	5	3.2.19.3.2.1.1.2 PBIT shall complete within 2 minutes of power application .
5	3	5	3.2.19.3.2.1.2 The Weapon System shall automatically and periodically execute a Continuous BIT (CBIT) while it is operational without degrading Weapon System performance.
6	3	5	3.2.19.3.2.1.2.1 The CBIT shall detect and report Weapon System failures/faults that would prevent the Weapon System from meeting its mission requirements and isolate faults to the WRA level.

STAKEHOLDERS SHEET

Stakeholders and their Importance				
Scored: 1 (not very) to 5 (very important)				
Stakeholder	Description	Relative Importance (Is)		
1	PMA-266	5		
2				
3				
4				
5				
6				
7				
8				
Importance of each Requirement to Each Stakeholder				
Scored: 1 (not at all) to 5 (extremely important)				
leave data on unused requirements blank				
(Vsr)				
Requirement Number	Stakeholder 1 PMA-266	Stakeholder 2	Stakeholder 3	Stakeholder 4
1	3	0	0	0
2	3			
3	3			
4	3			
5	3			
6	3			

ASSESSMENT SHEET

Basic Cost and Schedule Estimates for each Concept

Cost and Schedule Estimates for each Concept
 These values should be set to the estimate to implement each concept without adding incremental cost or schedule to fix deficiencies or to improve the ratings.

Estimated	Concept A	Concept B	Concept C
Name	SMS-1	SMS-2	PIU Mod
Base Cost (Bc)	\$960	\$720	\$0
Base Schedule (Tc)	0	0	0

in \$K values
in calendar weeks

How Well Each Concept Meets the Requirements (and what it will take to improve the rating)

Raw Score: How well each unimproved concept meet the requirements 1 (not at all) to 5 (extremely well)
Incremental Cost: How much it will cost to improve the requirement rating by one unit
Incremental Schedule: How much it will length the schedule to improve the requirement rating by one unit

Requirement Number	Raw Score (Rcr)			Incremental Cost (Ecr)			Incremental Schedule (Acr)		
	Concept A	Concept B	Concept C	Concept A	Concept B	Concept C	Concept A	Concept B	Concept C
1	3	3	3	\$0	\$0	\$0	0.00	0.00	0.00
2	3	3	3	\$0	\$0	\$0	0.00	0.00	0.00
3	2	2	2	\$80	\$100	\$21	0.36	0.45	0.10
4	3	3	3	\$0	\$0	\$0	0.00	0.00	0.00
5	1	2	2	\$80	\$100	\$21	0.36	0.45	0.10
6	1	1	2	\$80	\$100	\$43	0.36	0.45	0.19

SOLUTIONS SHEET

Determine the "Best Value" concept, its Cost, and its Schedule

Find Best Value Concept	Winning Concept:	SMS-2
Find Lowest Cost Concept	Required Budget	\$5,020 (\$K)
Find Shortest Schedule Concept	Required Schedule	19.2759 (Weeks)
	Final Rating	6770

Concept:	SMS-1	SMS-2	PIU Mod
Find Best:	Value	Value	Value
Find Min:	Cost	Cost	Cost
Find Min:	Schedule	Schedule	Schedule
Feasible?	Yes	Yes	Yes
Cost:	\$10,560	\$5,020	\$6,670
Schedule:	43.0	19.3	29.9
Score:	5600	6770	5420

Raw Concept Score for each Stakeholder

Stakeholder	Concepts		
	SMS-1	SMS-2	PIU Mod
PMA-266	1120	1354	1084
	0	0	0
	0	0	0
	0	0	0
	0	0	0
	0	0	0
	0	0	0
	0	0	0
	0	0	0

Key	
	= target cell
	= decision variable
	= constraint
	= (user supplied) data
	= results

MODEL RESULTS

<u>Concept:</u>	SMS-1	SMS-2	PIU Mod
<u>Find Best:</u>	Value	Value	Value
<u>Find Min:</u>	Cost	Cost	Cost
<u>Find Min:</u>	Schedule	Schedule	Schedule
<u>Feasible?</u>	Yes	Yes	Yes
<u>Cost:</u>	\$7,780	\$5,020	\$6,670
<u>Schedule:</u>	30.9	19.3	29.9
<u>Score:</u>	5600	6770	5420

CONCLUSION

“SE Trade Study Model and the implementation of this model in Excel™ was critical to the quality of the Fire Scout SMS Trade Study.”

-PMA-266 DPM

“Original study failed to consider the schedule impact of not meeting the safety requirements and over emphasized the integration effort.”

-Prime Vendor PM

Slides

**NPS Capstone Integrated Project
NPS Student Team RT19 Project**



NAVAL
POSTGRADUATE
SCHOOL

How the Degree of Accuracy of an Inertial Measurement Unit (IMU) Influences the Miss Distance of a Gun-Launch Precision Munition

David W. Panhorst
PD-21, Cohort 10
September 2011

Monterey, California
WWW.NPS.EDU



NAVAL
POSTGRADUATE
SCHOOL

Acknowledgements

To Mr. Thomas Recchia, Mr. Mauricio Guevara, and Mr. Daniel Smith, without your ability to write the code that allowed for the simulation work on the perfect trajectory and MATLAB® introduction of Inertial Measurement Unit (IMU) bias stability error, this thesis simply does not exist. Your behind-the-scenes detail work made it possible to answer the research question

To the members of the SEM PD-21 cohort 10, you are an unbelievable group. I cannot believe how much I learned from all of you, and what a special bond we made in such a short time. Special thanks go to Mr. Scott Lyon and Mr. Chris Ritchey for their participation in the Functional and Form Decomposition work we did as part of our final project in PD21SA-Systems Architecture. Your efforts are greatly appreciated.

- Research Motivation
- Functional/Form Decomposition
- Research Approach
- Results
- Key Points and Recommendations
- Significance of Research
- Areas for Further Research
- Lessons Learned

Research Motivation

- Motivated by work conducted on the Common Guidance program to develop an IMU common across multiple users in order to lower IMU unit cost
 - Gun-launch
 - Missiles
 - Bombs
- One Army leader wanted a quantified answer to the question “What does 1 degree/hour buy me?” (Machak, 2006)
- Develop a quantified answer

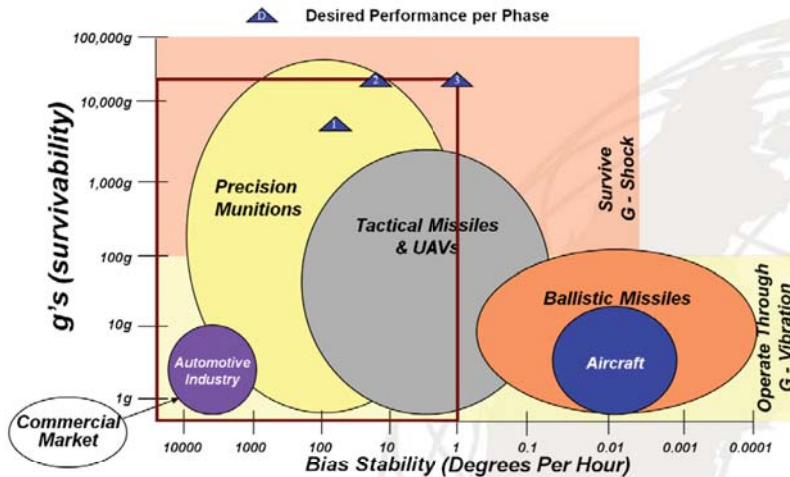

IMU Performance Demands (After Panhorst, et al, 2004)



- Collateral Damage
 - “even “precise” weapons can land at precisely wrong locations and cause incidents of unintended suffering” (Roblyer, 2003, p. 5)
 - Understanding factors that affect the precision of guided projectiles is critical to minimizing collateral damage and the negative social and political aspects of operations.



Function/Form Decomposition

Precision Munition Functional Decomposition

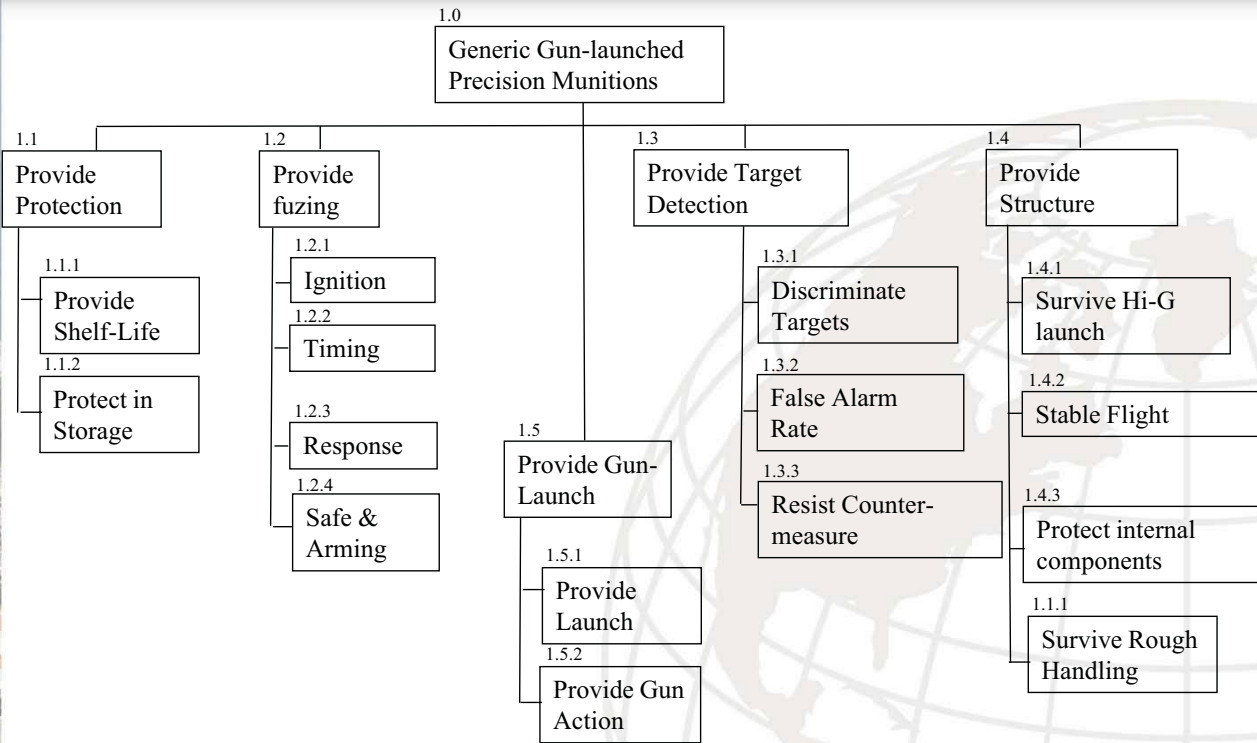

Precision Munition Functional Decomposition (continued)

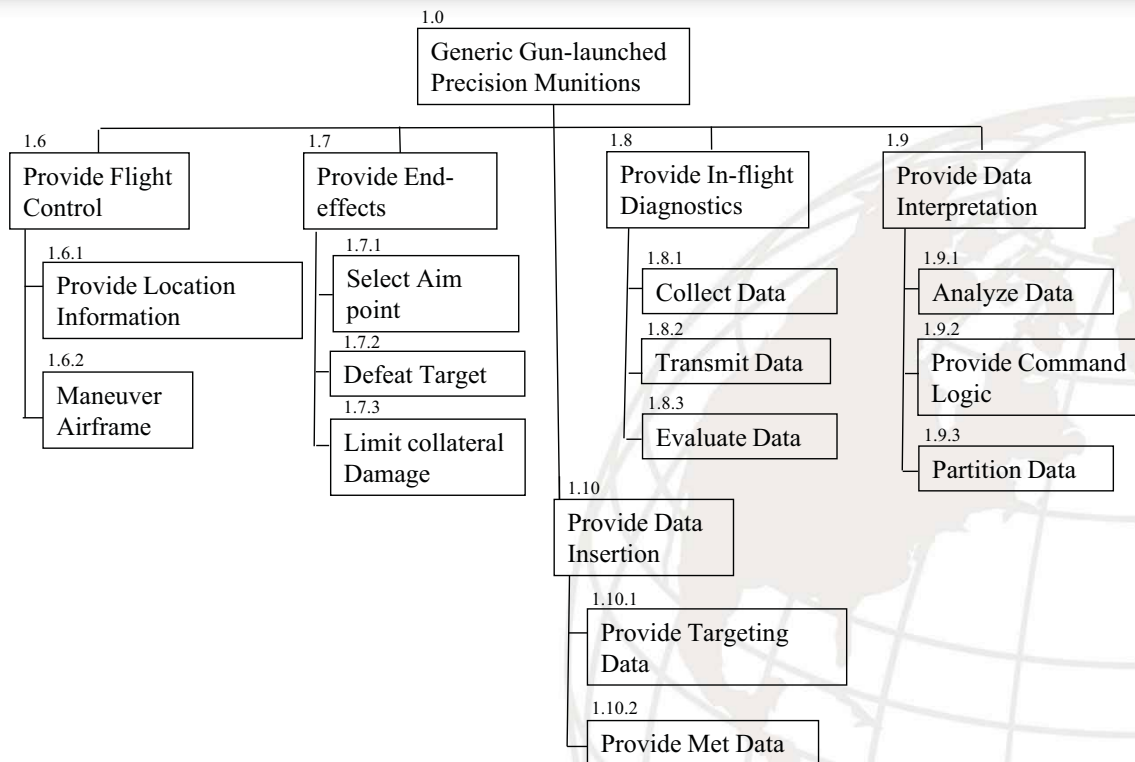

Precision Munition Form Decomposition

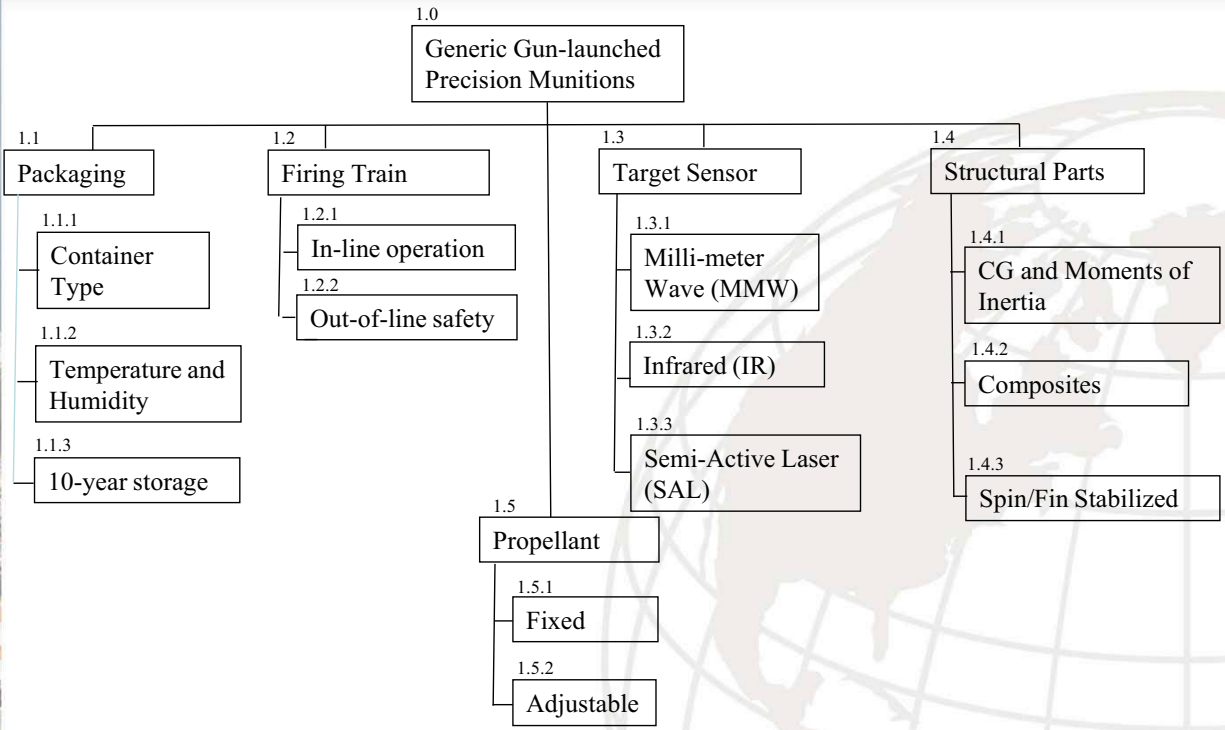

Precision Munition Form Decomposition (continued)

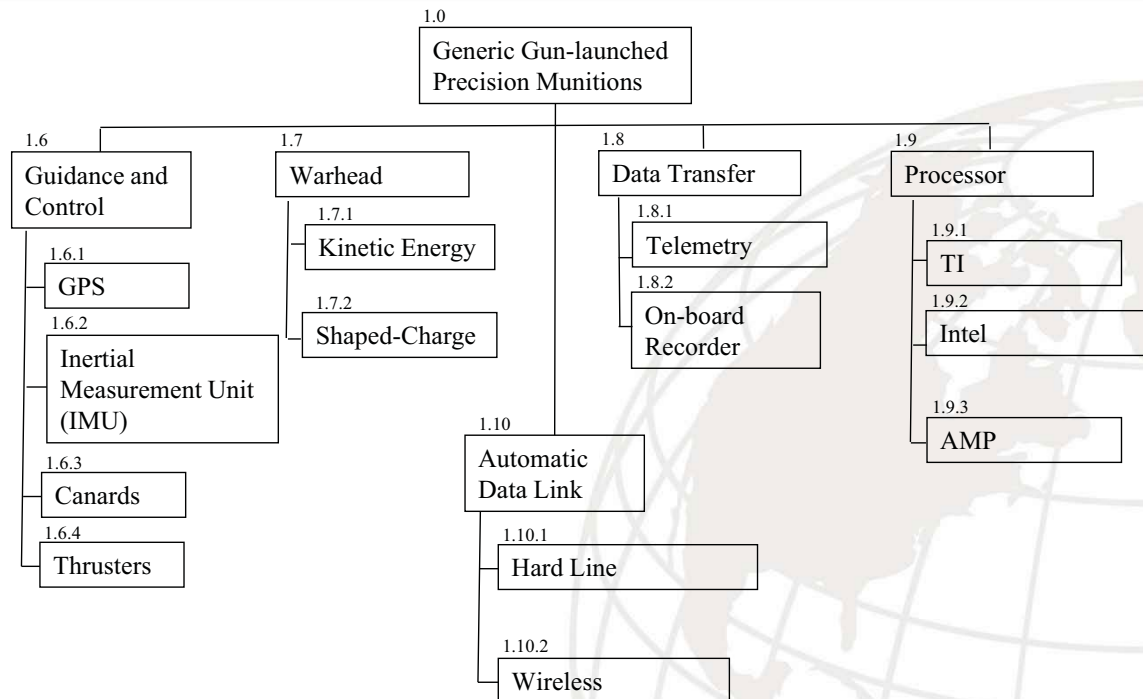

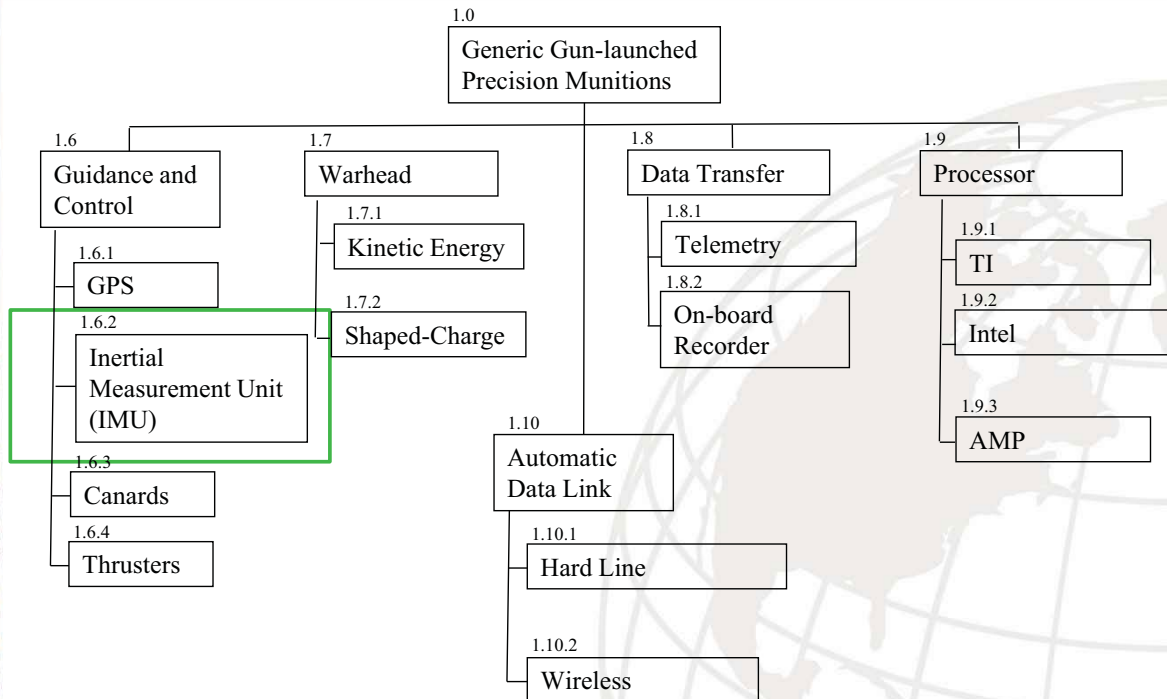

- IMU is a device that measures the acceleration and rotational changes of a projectile that is in flight along a trajectory
- By measuring deviation in angle rate and acceleration along the trajectory, the IMU provides data so the projectile can “course correct” and maneuver itself back to its intended flight path
- Output signals from the IMU are mathematically integrated and corrective instructions are relayed to the flight control system to make trajectory corrections.

- Accelerometer and gyros sensors are mounted in 3-axis configuration.
- Sensors measure changes in movement in the forward, right, and down direction
 - For the simulation the x direction is north, the y direction is east, and the z direction is down toward the center of the earth

15

- 6 Sensors (3 gyros, 3 accelerometers) measure changes in the six degrees of freedom

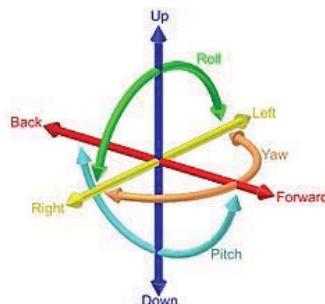

The six degrees of freedom forward/back, up/down, left/right, pitch, yaw, roll (From Wikipedia, 2011)

16 95

- Gyro bias is typically measured in angular degrees/hour, and accelerometers bias is measured in milli-g's
- To illustrate gyro bias, consider the following:
 - An operating IMU is placed on a table and left to run
 - It is placed such that its x-axis is facing exactly due north and it is located on the equator, thereby eliminating the contribution of the earth's rotation on the vertical gyro
 - After one hour, an IMU with a 1 degree/hour gyro bias will still be pointed north, even though its coordinate system has drifted from due north 1 degree in either direction
- To illustrate accelerometers bias, consider the following:
 - The same IMU is placed on a table at the equator and left to run
 - It measures 0 g in the north and east directions 1 g pointed toward the center of the earth (the weight of the unit)
 - After one hour, an IMU with a 1 mg bias will weigh the same, and think it has gained (or lost) 1 mg

17

WWW.NPS.EDU

Research Approach

18 **96**

WWW.NPS.EDU

- Perfect Trajectory using aeroballistics data generate by Aeroballistics Rapidly Evolving Simulation (ARES)
 - Flight in MATLAB®/Simulink with zero IMU error matches perfect trajectory results
 - Subroutine included to introduce IMU error
 - Subroutine allows for the isolation of IMU error contribution to miss distance
 - Since an independent sensor measures each axis of relative motion, the error of each axis varied for each of 5000 Monte Carlo simulation run
 - Error values were assumed to be 1-sigma
 - External effects held constant
 - Weather conditions
 - Launch conditions
 - Aeroballistics characteristics
 - Mass properties

19

WWW.NPS.EDU

- Trajectories simulated using the characteristics outlined below using Aeroballistic Rapidly Evolving Simulation (ARES)

Initial Conditions:

QE = variable between 600 mils and 1000 mils

AZ = 0 deg

Muzzle velocity = 800 m/s

Tipoff magnitude = 2 rad/s

Tipoff direction = 45 degrees, up and to the right

Projectile Characteristics (using standard M795 as basis):

Reference diameter = 0.155 m

Projectile mass = 219.2121083 kg

Center of gravity = 5.5 calibers

Axial moment of inertia = 0.708391082 kg m²

Transverse moment of inertia = 36.35466996 kg m²

Fin-cant to impart slow roll

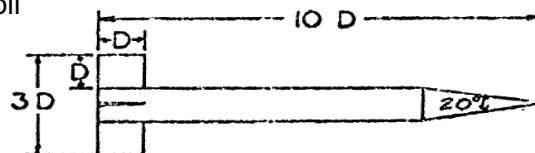

- The chosen QEs ensured that, for these airframe characteristics, the projectile would achieve its maximum range
- QE is defined in mils. There is 2000π milliradian (mrad) in a circle, meaning there are 6283.185 mrad in a circle. (Wikipedia)
- Army mils are calculated rounding π to a value of 3.2 resulting in 6400 mils in an Army mils circle
- Therefore,

QE	
Mils	Degrees
600	33.75
700	39.375
800	45.00
900	50.625
1000	56.25

QE	Range
600mils	30,335m
700mils	32,149m
800mils	33,177m
900mils	33,247m
1000mils	32,200m

Results

Simulation Specs: QE, Gyro Bias and Accelerometer Bias

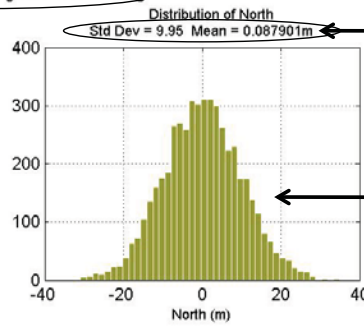
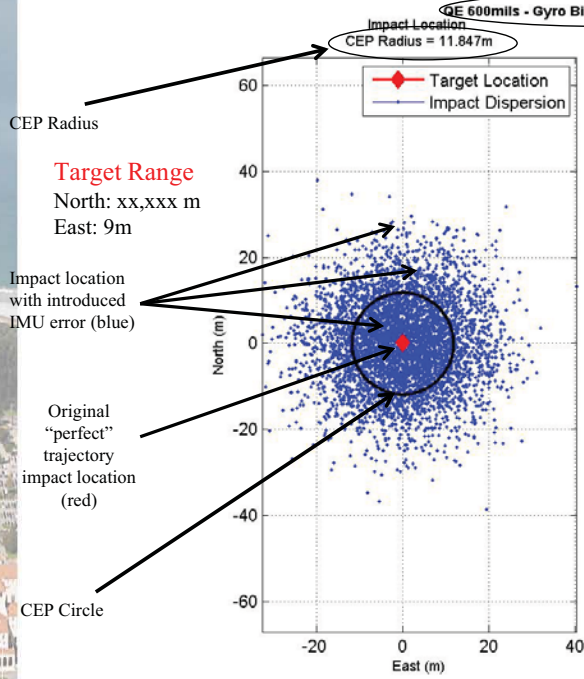

Mean and Standard Deviation in the North Direction

North Direction Distribution Histogram

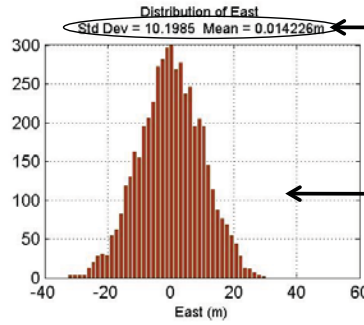

Mean and Standard Deviation in the East Direction

East Direction Distribution Histogram

Max Range Results

QE	1deg/hr and 1mg	20deg/hr and 4mg	75deg/hr and 9mg
600mils	1.7543m	11.8470m	35.4615m
700mils	2.1543m	15.1116m	45.4455m
800mils	2.6601m	18.5371m	55.8079m
900mils	3.0603m	21.2143m	63.5117m
1000mils	3.3217m	22.6314m	67.3433m

1deg/hr, 1mg provides a 95.18% improvement over 75deg/hr, 9mg

- What is the impact on miss distance if a specification requirement meant to be a 3-sigma value is interpreted as a 1-sigma value?

1-sigma

QE	1deg/hr and 1mg	20deg/hr and 4mg	75deg/hr and 9mg
600mils	1.7543m	11.8470m	35.4615m
700mils	2.1543m	15.1116m	45.4455m
800mils	2.6601m	18.5371m	55.8079m
900mils	3.0603m	21.2143m	63.5117m
1000mils	3.3217m	22.6314m	67.3433m

3-sigma

QE	1deg/hr and 1mg	20deg/hr and 4mg	75deg/hr and 9mg
600mils	0.5838m	3.9448m	11.8514m
700mils	0.7171m	5.0361m	15.1715m
800mils	0.8867m	6.1704m	18.6616m
900mils	1.0173m	7.0633m	21.1036m
1000mils	1.1062m	7.5481m	22.4726m

3-sigma provides a 200.83% improvement over 1-sigma, but could adversely impact IMU cost

- A 95.18% improvement in the accuracy is achieved with a 1 degree/hour, 1 mg bias stability IMU over one with a 75 degree/hour, 9 mg.
- Although limited to a generic airframe with fixed external conditions, the research results in a model to quantify the effect of IMU stability bias error on miss distance
- Tighter specifications significantly improved miss distance, in turn minimizing collateral damage while supporting a lower per unit cost for IMU production

- Driving gun-launched IMU requirements to tighter specification means better performance as well as cost savings
- Quantifies the outcome of what happens when specifications are not clearly written and left open to interpretation
- Generic setup conditions provided a platform to develop a subroutine within MATLAB® that serves as the foundation for IMU evaluation
 - This research results in a tool for the investigation of additional IMU error parameters and performance evaluation. It serves as the foundation for development of future accuracy requirements for gun-launched precision munitions.

- Apply the model to a spin-stabilized projectiles
- Consider the external influences on the projectile
 - investigate global weather patterns to determine average environmental conditions and including them in the model.
- Include mass property fluctuations by conducting a metal parts tolerance stack assessment
 - determine the effects of mass offset and misalignments on miss distance.
- Conduct a cost assessment of specification requirements
 - 1-sigma versus 3-sigma excursion showed a 200% increase in miss distance
 - Meeting the 3-sigma condition could potentially result in more IMU rejects for not meeting specification, and quantifying the cost impact of this could be of interest.

- Work towards a common goal
 - Course work that builds towards your thesis will greatly reduced the workload at the end.
- Use the NPS thesis template
 - Requires input to make sense
- Carefully document references
 - Final documentation will be time consuming
- Directing the research is OK
 - Stick to your strengths
- Pick a topic that you are passionate about
- Remember, life gets in the way

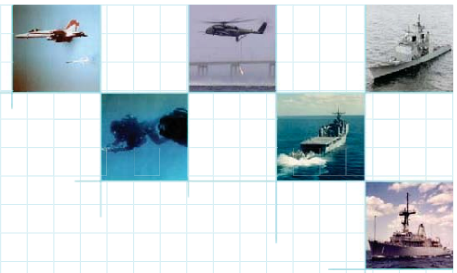

Clandestine Offensive Maritime Minefield Placement System (COMMPS)

An Analysis of Proposed Solutions for a Clandestine Offensive Maritime Mining Capability

Panama City Cohort

Section 311-101S

September 2011

- Introduction
- Background / Problem Definition
- Capability Analysis
- System Solutions
 - Functional and Physical Refinement
- Further Analysis
 - Minefield Delivery Timeline
 - Delivery Accuracy
 - Probability of Being Detected
 - System Cost
 - Time to IOC
- Results / Conclusions

- The Panama City cohort is made up of eight students that are employed full-time at the Naval Surface Warfare Center – Panama City Division (NSWC PCD)
- This capstone project was the culminating effort in the Master of Science – Systems Engineering (MSSE) program
- The team members are:

Andrew Blair (Project Lead)	Zena Le
Kate Brackett (CHENG)	Dawn Manga
Kyle Brown	Ivan Pereira
Matt Chastain	Lori Zipes

3

- Mining is a potentially cost effective method of warfare
- Mines can be used to control the maritime battlespace
 - Trap enemy forces in their own harbors
 - Prevent enemy forces from entering other's harbors
 - Disrupt enemy shipping and maritime transport lanes
- When used correctly mines can be very effective tool
 - Low cost
 - Simple design
 - Persistent

In order to maintain maritime dominance the US needs an offensive mining capability



Air delivered

Quickstrike Mk 62/63

Bottom, magnetic/seismic
Weight: 500/1000 lbs
IOC: 1985
Air delivered



Quickstrike Mk 65

Bottom, magnetic/seismic/pressure
Weight: 2000 lbs
IOC: 1985
Air delivered



Submarine delivered

SLMM

Bottom, magnetic/seismic
Weight: 1000 lbs
IOC: 1987
Out of Service: Sept 2012
Submarine delivered

Out of Service: Sept 2012



TDD 71

Target Detection Device
Currently under procurement
Potential to include enhanced sensors and ability for remote control

Problem: With the imminent loss of the SLMM from inventory, the Navy will lack **any ability to mine in a clandestine manner.**

-
- Clandestine: characterized by, done in, or executed with secrecy or concealment
 - Why clandestine?
 - Reduce threat to minelayer
 - Element of surprise
 - Mk 62, 63, 65 are air delivered at low altitude, highly visible and vulnerable to attack.
 - New or revised mine designs that could be submarine delivered have not been adequately funded or developed.

In order to make mining a viable tool for maintaining maritime dominance, the Navy has an immediate need for a clandestine, offensive minefield placement capability.

- Key Constraints:
 - Viable near term solution (7 years to IOC)
 - Clandestine delivery method
 - Shallow water operation

7

- Defined High Level CONOPS
 - Including Reference Missions
- Developed Requirements
 - Sources Include
 - NWP 3-15 Naval Mine Warfare
 - NTTP 3-15.1 Maritime Mining
 - U.S. Naval Mine Warfare Plan
- Defined Measures
 - MOE: Timeliness of minefield placement
 - MOE: Accuracy of mine placement
 - MOE: Probability of being detected during minefield delivery
 - Additional Measures: Cost and Schedule

	RM 1	RM 2	RM 3
Minefield Size (yds x yds)	14K x 14K	6K x 6K	2K x 3K
Number of Mines	200	60	20
Minefield Layout	Random	Random	Two Lines
Standoff Range for Surface Host Vessel	200 nm	50 nm	50 nm
Standoff Range for Subsurface Host Vessel	20 nm	20 nm	20 nm
Max Average Surface Current	3 knots	3 knots	3 knots

- Concepts developed iteratively from research and stakeholder inputs
- Conducted feasibility screening to select best systems for further analysis
- Systems:
 - UUV delivered SLMM warheads, operating from a surface ship (UUV+SLMM)
 - SLMM Warhead: bottom mine, forward portion of the existing SLMM design
 - UUV delivered CRAW Multi-pac, operating from a surface ship (UUV+CRAW)
 - CRAW Multi-pac: developmental mine, Qty 4 encapsulated homing torpedoes
 - Improved Submarine Launched Mobile Mine (ISLMM)
 - ISLMM: developmental mine, based SLMM and MK 48 torpedo, adapted for 2 mines per unit

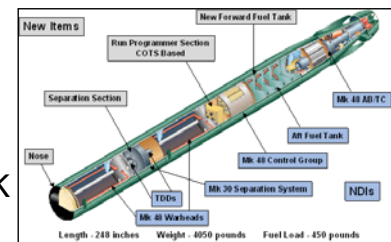

(United States of America Mines 2008)

9

Solution Concept Functional and Physical Refinement

- Refined solutions to create concept-level functional and physical architectures
- Functional refinement consisted of:
 - Concept of Employment – solution specific refinement of CONOPS
 - Functional Flow Block Diagrams
 - Event Trace Diagram
 - Failure Modes investigation
- Physical refinement consisted of:
 - Identification of major subsystems and interfaces
 - Assessment of internal design considerations
 - Assessment of external interfaces
 - Identification of areas of high technical risk
- Goal was to elaborate on the conceptual design to allow for further analysis of Performance, Cost, Schedule, and Risk
- Does not present a design ready for production

- Physical refinement started with selection of representative UUV
 - Large diameter UUV necessary for payload delivery capability
 - Existing designs considered: Theseus, Seahorse, Sea Lion, Sea Maverick, Sea Stalker, Proteus
- UUVs evaluated with regards to:
 - Speed
 - Endurance
 - Payload Capacity
- Proteus chosen for further analysis
 - Most closely represents the desired characteristics
 - A comparable LD UUV may be used with necessary redesigns

11

Proteus Properties

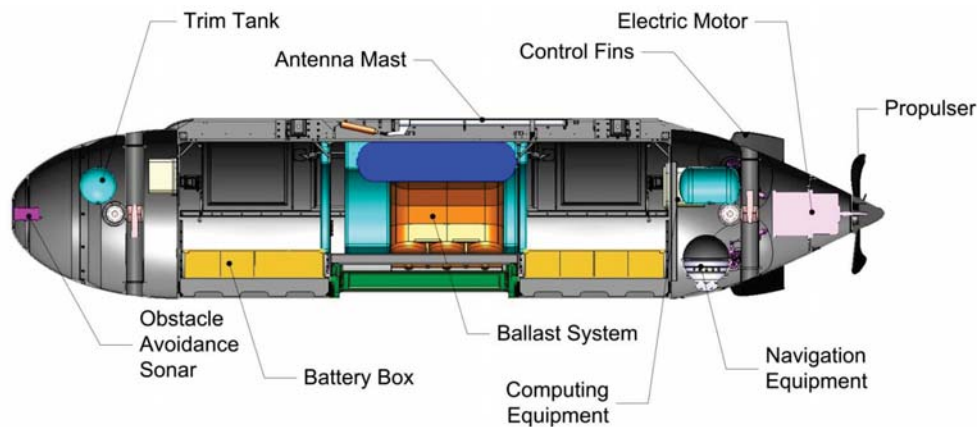

Images Source: Adapted from (The Columbia Group 2011b)

- Properties
 - Length: 25.7 ft
 - Diameter: 60 in
 - Weight: 6,200 lbs
 - Max. Depth: 300 ft
 - Payload Capacity: 3200 lbs. dry
 - Internal Payload Volume: 177 ft³
- Capabilities Include
 - Ballast System
 - Obstacle Avoidance
 - Manned/Unmanned Control
- Prototype in production, TRL 6

- Conducted Minefield Delivery Timeline Analysis
- Conducted Delivery Accuracy Analysis
- Examined Probability of Being Detected
- Developed System Cost
- Defined Time to IOC

13

- Time analysis begins with the host platform in position and the first delivery platform being launched
- Time analysis ends when entire minefield is laid and all recoverable assets are recovered
- Analysis developed as an Excel simulation
- Three alternatives: UUV+SLMM, UUV+CRAW, and ISLMM
- Each Reference Missions examined

1409

	Reference Mission 1		Reference Mission 2		Reference Mission 3	
	Mission Time (days)	# vehicles	Mission Time (days)	# vehicles	Mission Time (days)	# vehicles
UUV+SLMM	Fail	8	14.4	2	8.6	1
UUV+CRAW	Fail	2	3.1	2	1.1	1
ISLMM	0.18	100	0.09	30	0.06	10

- UUV+SLMM fails RM 1 and is questionable for RM2 and RM3
- UUV+CRAW fails RM 1 and performs well for RM2 and RM3
- ISLMM performs the best of all the alternatives
 - Delivery speed results in fast mission completion
 - Launch rate of ISLMM is the only factor that increases the mission time as the number of mines is increased

15

UUV Delivery Accuracy

- Delivery accuracy is based on Inertial Navigation System and GPS
- Placement accuracy is dependent on distance travelled after last GPS signal
 - Expected accuracy is 0.05 – 0.1% of distance travelled
 - UUV: 182 ft (CEP) at 30 nm
 - ISLMM: 122 ft (CEP) at 20 nm
- UUV Solutions
 - UUV must surface to obtain GPS data for accurate minefield placement
 - Mission planners must determine the tradeoff between accuracy and detectability
- Ocean effects are significant
 - Further accuracy reduction due to drop height, current, bottom type
 - Planning can remove some error
 - Final mine location dependent on environment
- Placement Accuracy Effects on Minelines: Even marginal minefield placement accuracy can enable better minefield effectiveness
 - Requires further study

- Signatures
 - Acoustic
 - Magnetic
 - Optical (Visual, IR)
 - Radar
- Difficult to determine without final system designs
- Systems considered are primarily underwater and difficult to observe in a littoral environment
- All system signatures are acceptable

17

- Based on
 - Subsystems or components used in similar existing systems
 - Input from DoD SME's, Program Office Information, and Academic Experts
- Did not Address
 - Disposal Costs
 - Opportunity Costs
 - Programmatic Costs
 - DOTMLPF Considerations
- Assumptions
 - Life cycle of 22 years (7 years to IOC; 15 years from procurement to disposal)
 - Entering at MS-B
 - Production units based on mine placements ratios for similar capabilities
 - LCC UUV prod. units – 20
 - LCC SLMM Warhead prod. units – 1000, using existing inventory
 - LCC CRAW Multi-pac prod. units – 100
 - LCC ISLMM prod. units – 500

111

LCCE Conclusions

Solution	Cost in \$M (FY13)
UUV+SLMM	1,140
UUV+CRAW	955
ISLMM	3,320

UUV + SLMM
<ul style="list-style-type: none"> • Reuse of existing technologies • Reuse Weapons Certs • Reuse of Inventory • Large # of production Units

UUV + CRAW
<ul style="list-style-type: none"> • Lowest Cost • Lower Unit Cost • Reuse of Captor Casings • New Weapons Certs • R&D Costs • Integration Risks

ISLMM
<ul style="list-style-type: none"> • Sophisticated Technologies • New Weapons Certs • Testing/Destruction Costs

Note: All costs are estimates

Overall Analysis Results

Solution	MOE								Lifecycle Cost (\$M)
	Mission Duration (days)			Accuracy (nautical miles)			Detection Probability		
	Reference Mission			Reference Mission			Type of Detection		
	1	2	3	1	2	3	Acoustic Ranking	Magnetic Ranking	
UUV+SLMM	FAIL	14.4	8.6	0.03	0.03	0.03	Acceptable	Acceptable	1,140
UUV+CRAW	FAIL	3.1	1.1	0.03	0.03	0.03	Acceptable	Acceptable	955
ISLMM	0.18	0.09	0.06	0.02	0.02	0.02	Acceptable	Acceptable	3,320

- ISLMM solution provides better performance than other solutions for MOEs, but at the highest lifecycle cost between solutions
- UUV solutions are unable to complete RM 1
- UUV+SLMM solution is questionable in RM 2 and 3
- UUV solutions have value for the U.S. Navy due to submarine tasking in other warfare areas

Reference Mission #1

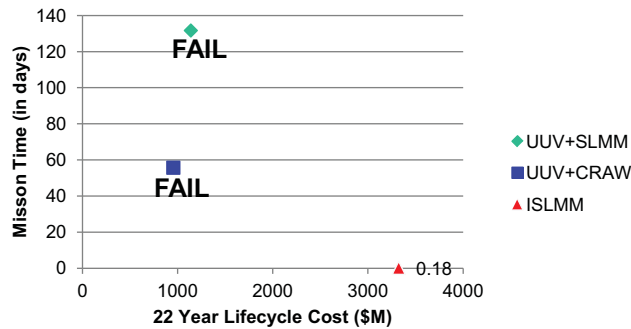

Reference Mission #2

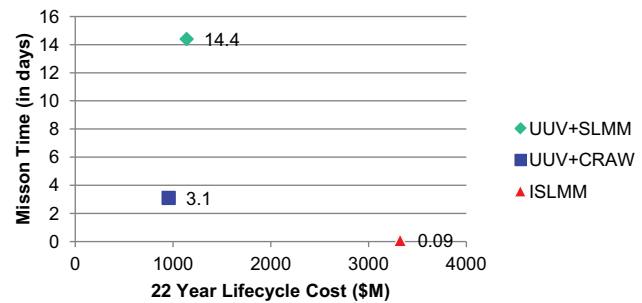

Reference Mission #3

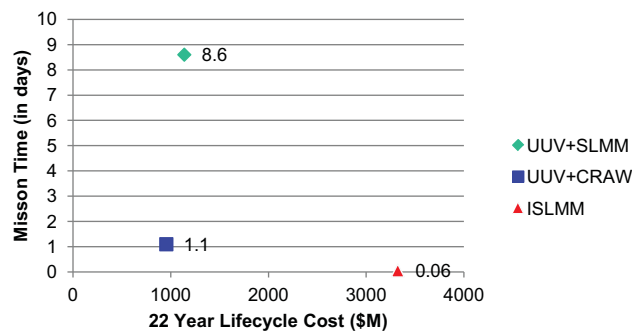

- ISLMM most time efficient solution, but at a cost of at least 3 times the other solutions
- Decision maker will need to decide if UUV mission time is acceptable for a missions given the lower cost.

21

Risks and Issues

- UUV+SLMM Solution
 - Prototype UUV used for analysis
 - UUV battery certification
 - Required software upgrades to UUV
- UUV+CRAW Multi-Pac Solution
 - Same risks as UUV+SLMM solution
 - Design, testing, and certification of the multi-pac configuration
- ISLMM Solution
 - SLMM needs to be significantly upgraded
 - Design, testing, and certification for new ISLMM required
- Issues
 - UUV integration with current surface ships
 - Mine storage capability onboard Ohio class submarines
 - Political and financial considerations for mining programs
 - Logistics and training support for COMMPS

- U.S. Navy has a need for a clandestine offensive mining system
- Detailed analysis performed on three solutions
 - UUV+SLMM from surface ship
 - UUV+CRAW Multi-Pac from surface ship
 - ISLMM from submarine
- MOEs Defined
 - Mission timeliness
 - Mine placement accuracy
 - Probability of delivery platform being detected
- Minimizing standoff range of platform increases COMMPS mission success for all solutions
- ISLMM solution can complete all defined reference missions, but at a higher cost

23



- Coastal Systems Station. "U.S. Navy Mine Familiarizer." September 2000.
- Koch, Andrew. "US Navy to Start Ohio Conversion." *Jane's Defence Weekly*, August 2001.
- McMullen, Dr. Teresa. *Compact Rapid Attack Weapon (CRAW) Overview*. July 2, 2009.
- The Columbia Group. E-mail message from David DeMartino to Matthew Chastain. August 29, 2011a.
- The Columbia Group. E-mail message from Karl Lindman to Katherine Brackett. July 25, 2011b.
- *United States of America Mines*. November 30, 2008. http://www.navweaps.com/Weapons/WAMUS_Mines.htm (accessed June 19, 2011).

DATA TO DECISIONS AS IT HAPPENS



S.P.E.A.R.S.

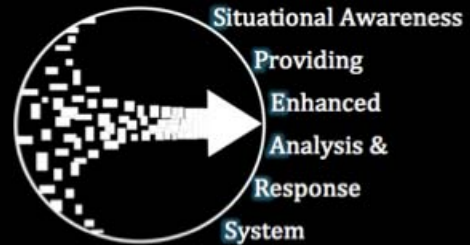

NAVAL
POSTGRADUATE
SCHOOL

RT-19 IPR SPEARS

LCDR Loren Jacobi
LT Matt O'Connor

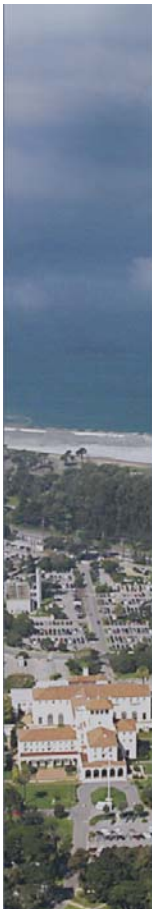

The Nation's Premiere Defense Research University

2 Monterey, California
WWW.NPS.EDU

Distribution
Statement A

USG HUMANITARIAN ASSISTANCE TO JAPAN FOR THE EARTHQUAKE AND TSUNAMI

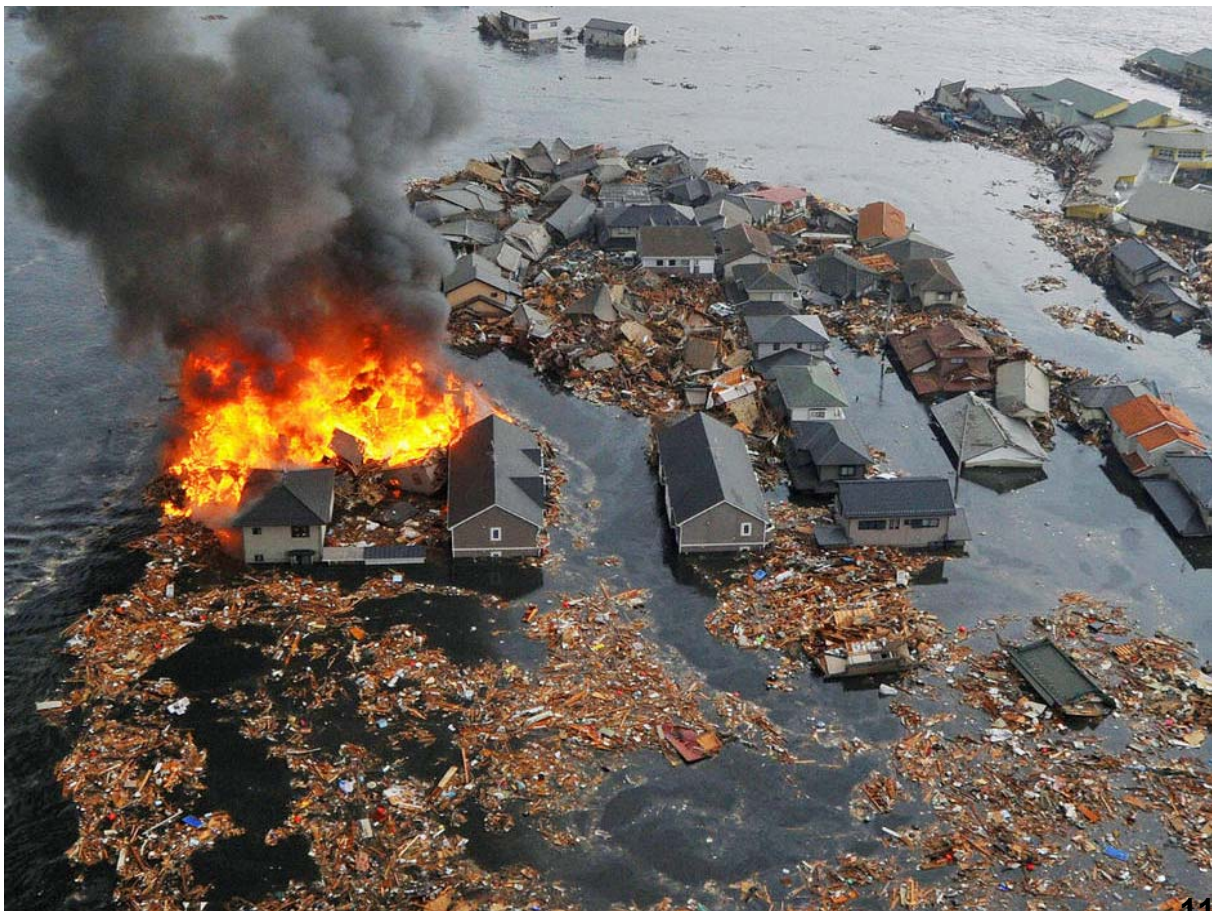
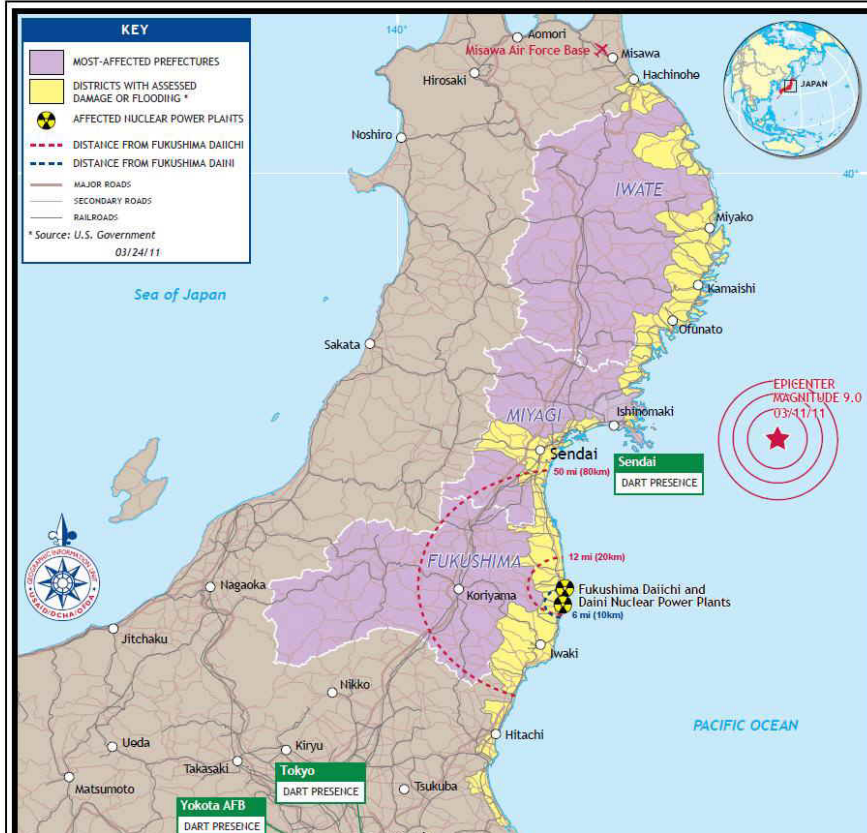





Data To Decisions

Most is Unstructured and Hard to Extract Meaning, Patterns, Trends
The *Real Time* Web Makes This Even Harder

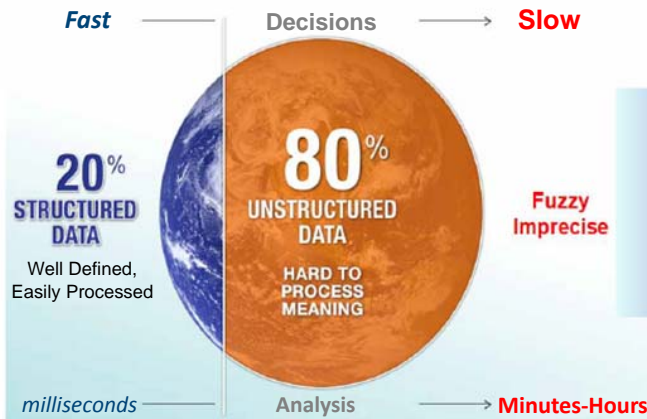

RESEARCH TOPICS

- *Data Structure*
- *Anomaly detection*
- *Embedded algorithms*
- *Context*
- *Prediction*

Source: TTI Vanguard Conference - Psydex

White House QDR brief for Science and Technology 04 NOV 2010



SPEARS

- **Situational Awareness**
- **Providing**
- **Enhanced**
- **Analysis**
- **Response**
- **System**





Bottom Line Up Front

Data

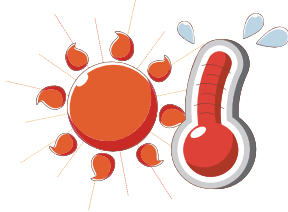

SA



PROg

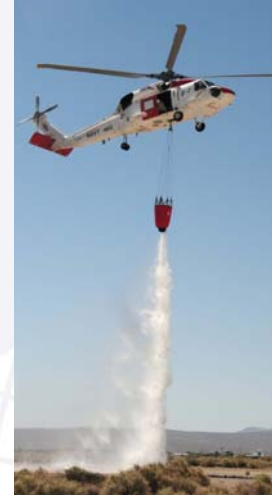

RT-19 Directed by DDR&E

- 48 officers, 5 professors, 8 industry advisors

***Impacts 1.5 M people –
Entire DoD***

- Equivalent to > \$100M procurements
- Global impact across full spectrum of missions
 - Scalable Data to Decisions architecture



Problem Development

- PACOM / AFRICOM stakeholder analysis
 - Ability to response to wide spectrum of missions
 - Latency of data
 - 1-3 day capability gap
 - Union space: Combatant Commanders need timely information

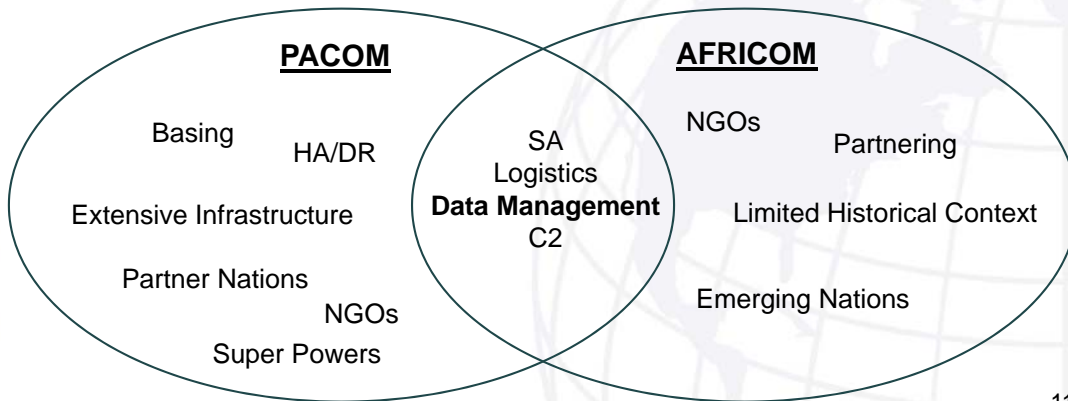

Problem Development

- Latency of information
 - Quantity (not equal to) Quality
 - No value added
 - Manage complexity of data resources
- Latency of response
 - Wrong tools at the right place
 - Right tools at the wrong place



Needs Analysis

- Decision support (Data to Decisions)
 - Timely information
 - Cohesive situational awareness
 - Correlate multiple sources of information
 - Reduce noise and volatility of multi-source reporting
 - Prognostication (PROg)
 - Prediction of likely impacts
 - Historical / data-driven context

WWW.NPS.EDU



Requirements Analysis

- System shall...
 - Collect information from multiple sources
 - Process data to develop situational awareness
 - Provide decision maker with value-added information to reduce response time
 - Generate an initial prediction of potential outcomes based on system defined parameters and existing metadata

WWW.NPS.EDU



- 1.0 Aid Decision Maker
 - 1.1 Decision support
 - 1.2 Utilize Communications infrastructure
 - Open source / unclassified data
 - RSS feed(s) (Resource description framework Site Summary)
 - 1.3 Gain/Maintain SA
 - 1.4 Aid PROg
 - 1.5 Display relevant information

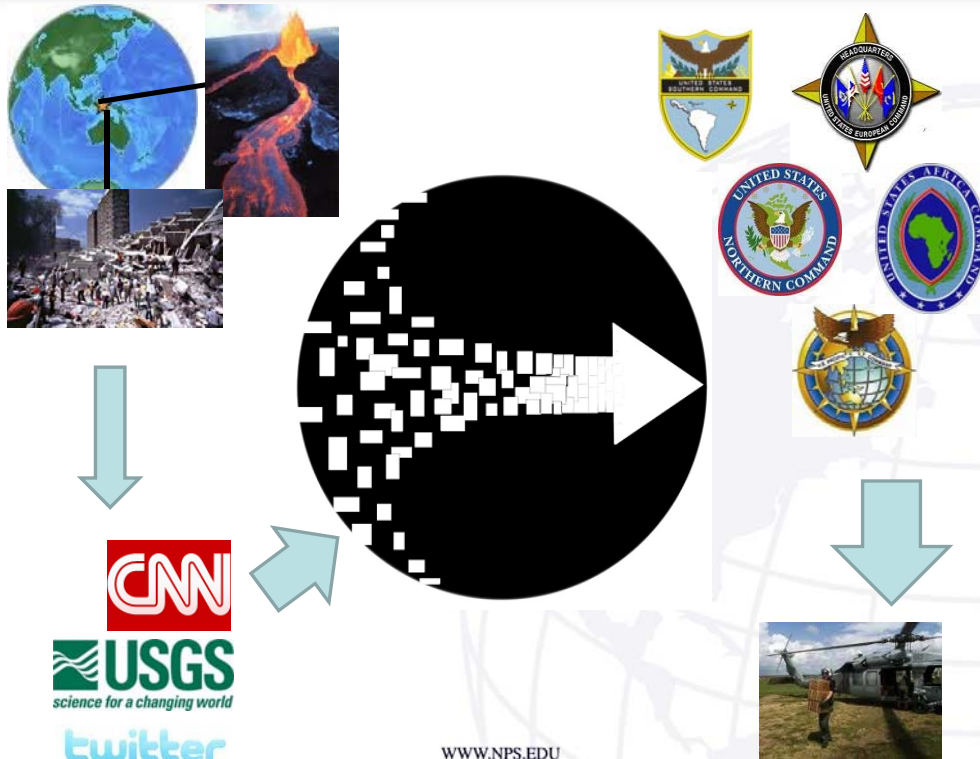



SPEARS Functional Flow

- Functional Flow Block Diagram

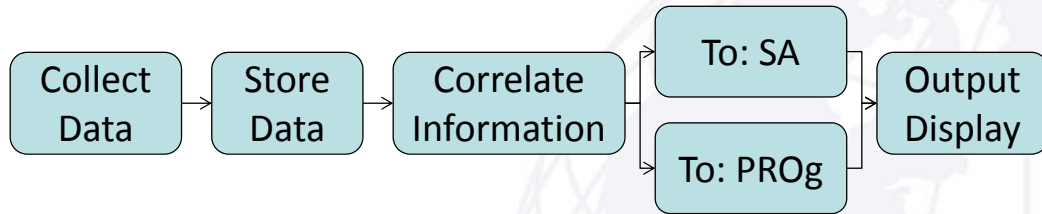

SPEARS Architecture

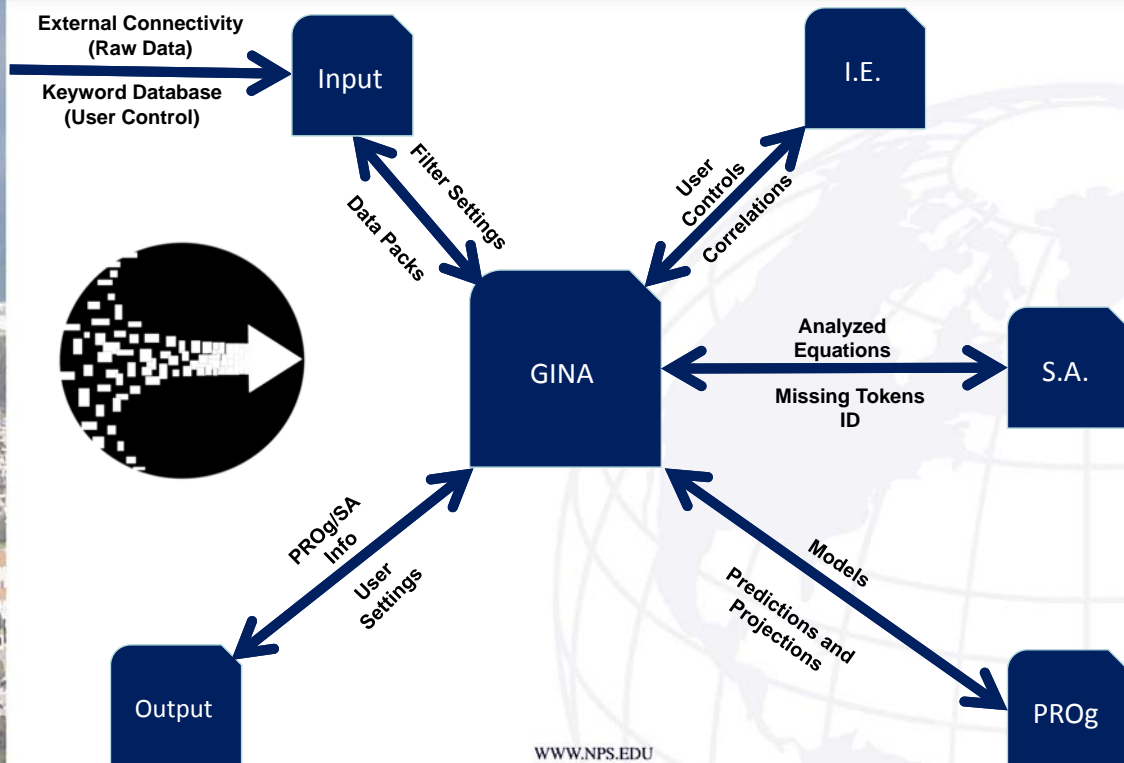



- Correlate all data
 - Analyzes available data
 - Continuously correlates related data
 - Correlation based on linear regression
 - Time and space
- Provide correlated data to SA and PROg
 - Display ground truth
 - Predictive tools



- Global Information Network Architecture
 - Application Program Interface
 - Semantic Language Processor
 - Interface manager
 - Universal translator between elements
 - Created and developed by Big Kahuna Technologies under CRADA with NPS
 - Available for US Government use



SPEARS Architecture

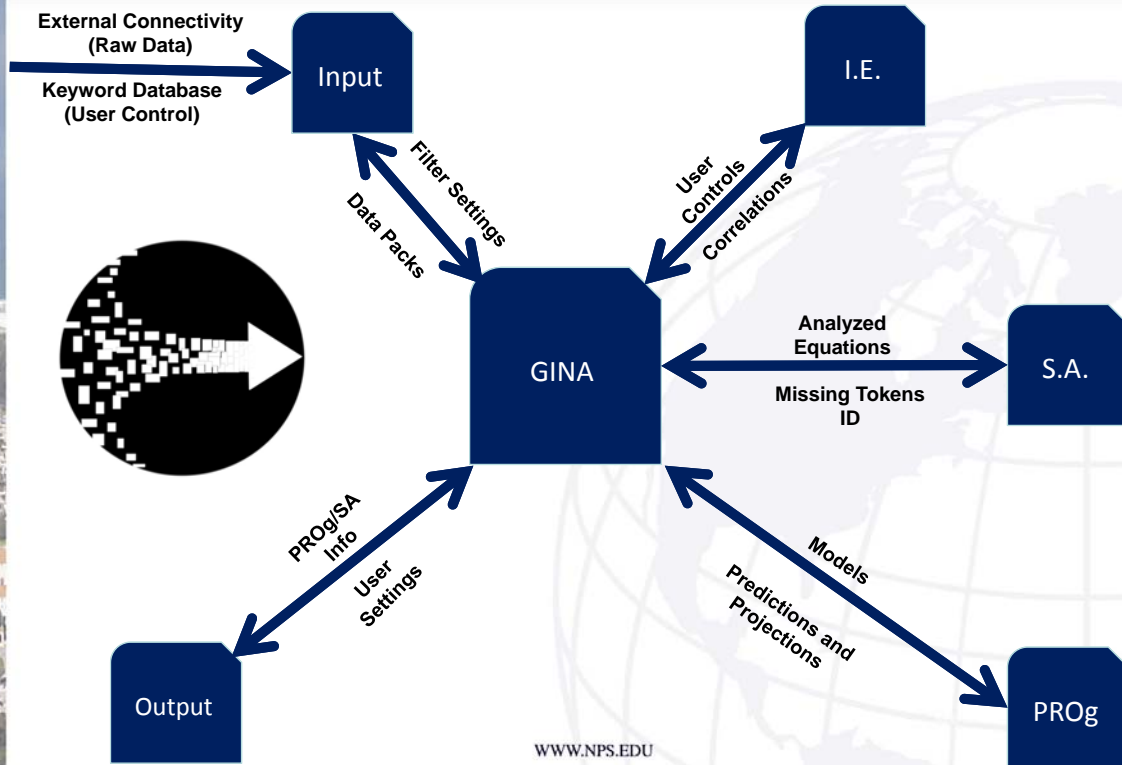

Database Management

- GINA maintains:
 - Event characteristics
 - SA and PROg outputs
- Provides data for Inference Engine
- Provides data for SA
 - From database to usable for mapping program
 - Excel2FV and / or Cursor On Target performs data conversion



- DOD standard mapping program
 - Stand-alone mapping (maps on hard drive)
 - Streaming maps (ARCGIS servers)
- Open Source freeware
 - DOD-authorized release from Georgia Tech Research Institute
- Single-source mapping interface for all HA/DR responders



- Early development
- Physical hardware
 - Desktop computer
 - 2 x video monitors
 - 2 TB hard drive
- Software
 - Windows 7 Pro
 - GINA
 - FalconView 4.2.1
 - Cursor On Target / Excel2FV





- Twitter trends:
 - Shaking
 - Earthquake
 - Broken windows
- News sources
 - Power outages
 - Fires
- *USGS RSS Feed*

twitter



USGS M 2.5+ Earthquakes

Real-time, worldwide earthquake list for the past 7 days

[M 3.4, Dominican Republic](#)

Wednesday, August 31, 2011 11:09 AM

August 31, 2011 18:09:14 GMT

[M 2.6, Central California](#)

Wednesday, August 31, 2011 8:21 AM

August 31, 2011 15:21:27 GMT

[M 2.7, Central Alaska](#)

Wednesday, August 31, 2011 8:19 AM

August 31, 2011 15:19:17 GMT

[M 4.7, Kuril Islands](#)

Wednesday, August 31, 2011 8:01 AM

August 31, 2011 15:01:06 GMT

[M 4.8, Carlsberg Ridge](#)

Wednesday, August 31, 2011 7:54 AM

August 31, 2011 14:54:08 GMT

[M 4.7, Philippine Islands region](#)

Wednesday, August 31, 2011 6:55 AM

August 31, 2011 13:55:34 GMT

[M 4.8, near the east coast of Honshu, Japan](#)

Wednesday, August 31, 2011 6:22 AM

August 31, 2011 13:22:42 GMT

[M 5.4, northern Mid-Atlantic Ridge](#)

Wednesday, August 31, 2011 5:17 AM

August 31, 2011 12:17:26 GMT

Magnitude	2.6
Date-Time	Wednesday, August 31, 2011 at 15:21:27 UTC Wednesday, August 31, 2011 at 08:21:27 AM at epicenter Time of Earthquake in other Time Zones
Location	35.726°N, 121.112°W
Depth	7.3 km (4.5 miles)
Region	CENTRAL CALIFORNIA
Distances	12 km (7 miles) NE (38°) from San Simeon, CA 19 km (12 miles) N (354°) from Cambria, CA 21 km (13 miles) W (266°) from Lake Nacimiento, CA 41 km (25 miles) WNW (286°) from Paso Robles, CA 193 km (120 miles) SSE (159°) from San Jose City Hall, CA
Location Uncertainty	horizontal +/- 0.2 km (0.1 miles); depth +/- 0.7 km (0.4 miles)
Parameters	Nph= 51, Dmin=4 km, Rmss=0.13 sec, Gp= 90°, M-type=duration magnitude (Md), Version=1
Source	California Integrated Seismic Net ; USGS Caltech CGS UCB UCSD UNR
Event ID	nc71631160



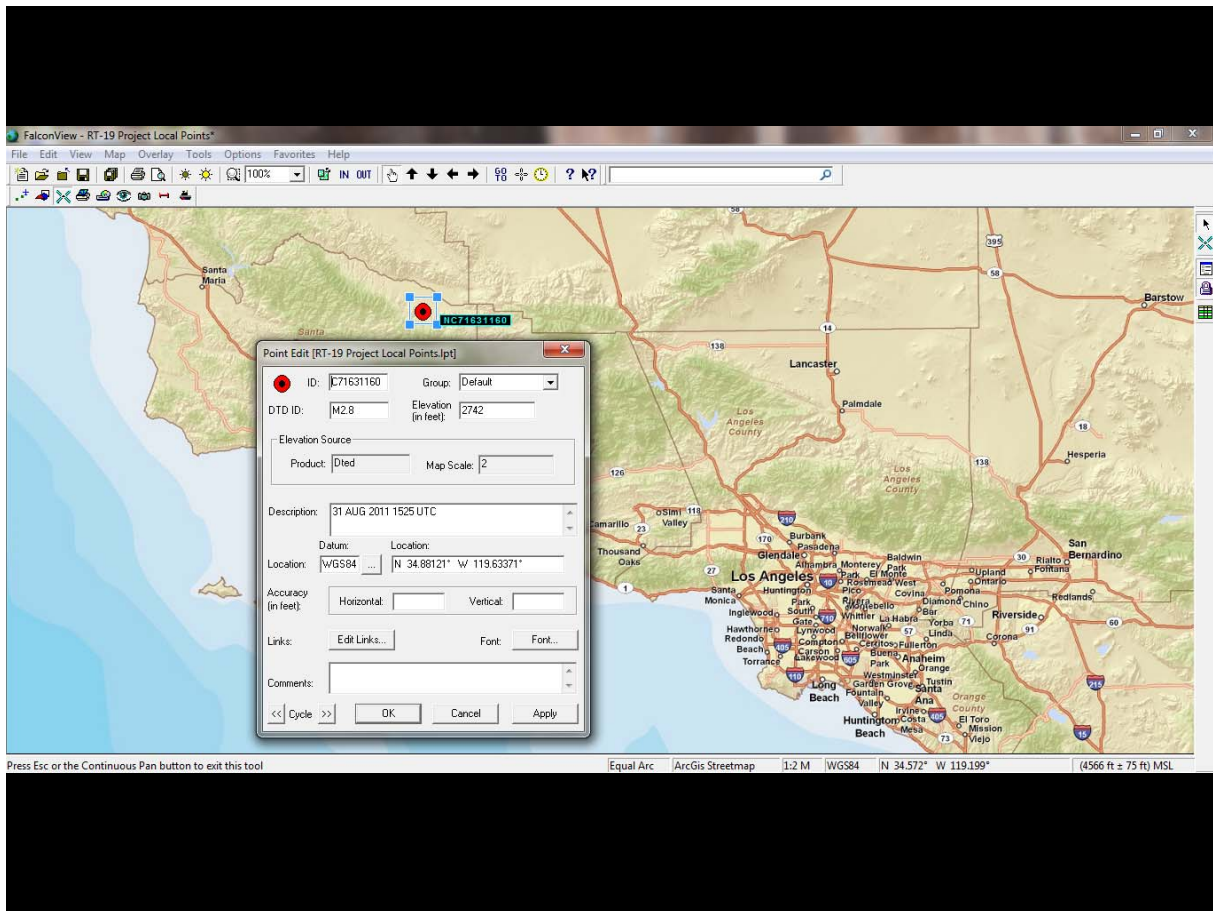

- SA defines problem
 - Earthquake in a large urban area (very likely)
 - Nuclear detonation (less likely)
 - Conventional explosion (extremely unlikely)
- Provide PROg
 - Size of affected population
 - Scope of response
 - Emergency response units
 - Utilities repair units
 - Identify possible secondary events
 - Fire
 - Tsunami

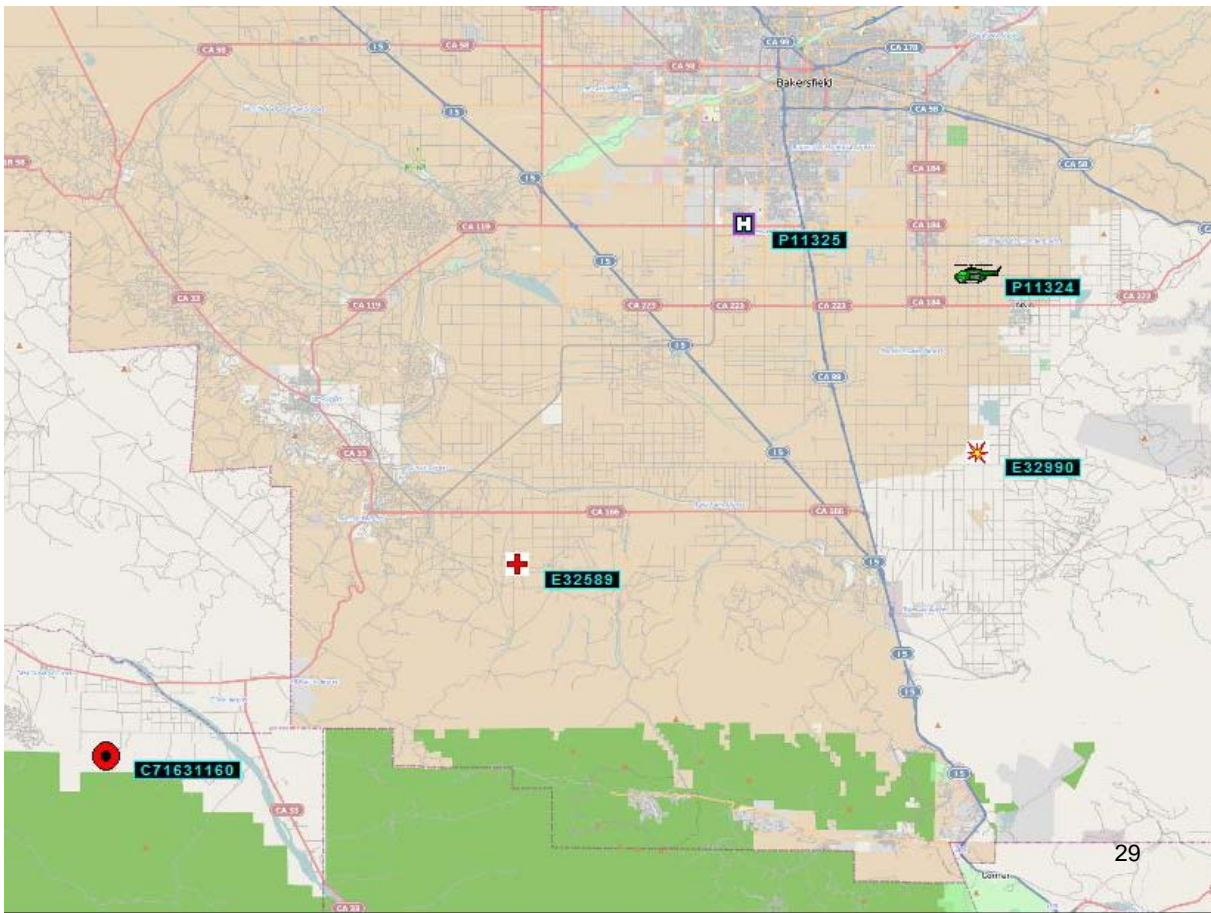

NAVAL
POSTGRADUATE
SCHOOL

Conclusions

- SPEARS offers way forward to close current capability gap
 - 1-3 day HA/DR response
- Architecture viable for other Data to Decisions applications
- Academic impact on 48 students
 - Exponential propagation throughout the Fleet





- Example Correlation and PROg
 - Poll United States Geological Survey (USGS) data and observations
 - Derive the magnitude of an earthquake and the estimated latitude and longitude of its epicenter
 - Provide an educated estimate of the potential wave height of a follow-on tsunami
 - Enable decision makers to assess the pending situation with more granularity on a shorter time horizon than is currently possible, so that less time can pass before an effective relief effort commences



- SPEARS mirrors existing doctrine for CIC data flow
 - Gather
 - Process
 - Evaluate
 - Display
 - Disseminate



- VTC Meetings with key stakeholders
 - 24JAN – AFRICOM Carter Greenwood
 - 4FEB – AFRICOM COL Jurrens
 - 11FEB – PACOM Jim Elhert
- Identified very different problem spaces for each command
 - PACOM – Data Integration/Management
 - AFRICOM – No Resources/No Data

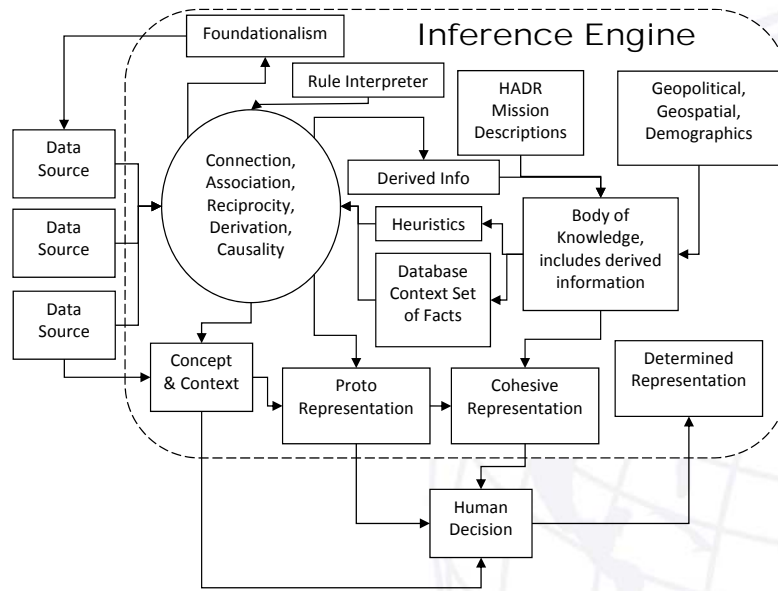

WWW.NPS.EDU

Student Distribution A Statements

.

THESIS RELEASE FORM				
Title:	Seeker Upgrade Options for Ship Self Defense Missile: An Analysis Based on Performance and Cost Constraints			Grad Date: Sep 2011
Author(s)	Phuong N. Lam			
Thesis Advisor(s)	Professor David H. Olwell and Professor Robert Harney			
Program Officer (GSEAS and OR Only)				
Curric Number: 721	Degree: MS <input checked="" type="checkbox"/> MA <input type="checkbox"/> ENG <input type="checkbox"/> MBA <input type="checkbox"/> PhD <input type="checkbox"/>			
Department Chair or Dean:	Professor Clifford Whitcomb			
APPROVAL FOR PUBLICATION TO THE NPS AND DTIC WEBSITES				
The undersigned certify that to the best of their knowledge, this thesis should be published for unlimited distribution. Criteria for release are: 1) quality is high 2) subject matter is relevant to Navy/DoD/government 3) thesis does not contain (individually or in aggregate with other theses) sensitive, proprietary or classified material.				
Author(s)	Yes <input type="checkbox"/>	No <input checked="" type="checkbox"/>	Signature(s) <i>Phuong Lam</i>	Date 8/17/2011
Advisor(s)	Yes <input type="checkbox"/>	No <input type="checkbox"/>	Signature(s)	Date
Program Officer	Yes <input type="checkbox"/>	No <input type="checkbox"/>	Signature (GSEAS and OR only)	Date
Chair/Dean	Yes <input type="checkbox"/>	No <input type="checkbox"/>	Signature	Date
If "No" is checked above and the student is International, use Distribution Statement F.				
HOLD <input type="checkbox"/>	Reason: This contains information derived from sections of Unclassified source documents bearing Distribution Statement F			Desired release date: Sep 2011
HUMAN SUBJECTS RESEARCH				
Does this research involve Human Subject Research? Y <input type="checkbox"/> N <input checked="" type="checkbox"/>				
If yes, list protocol number(s) here and in block 11 of Form 298, in thesis				
If yes, have end of experiment report and all supporting documentation, such as informed consent forms, been submitted to the Human Research Protections Office? Y <input type="checkbox"/>				
CERTIFICATION OF ORIGINAL WORK				
The undersigned certifies that the thesis is an original work of the author(s). Work of others has been appropriately cited.				
_____ Signature, Author(s)			_____ Date	
THESIS DISTRIBUTION STATEMENT: In view of the literary quality and technical content of this thesis, and the extent of its self-contained contribution to the field of knowledge, and the potential contribution to the reputation of the Naval Postgraduate School, it is recommended that the distribution of this thesis be as follows:				
Statement (select based on attached questionnaire): A <input type="checkbox"/> B <input type="checkbox"/> C <input type="checkbox"/> D <input type="checkbox"/> E <input type="checkbox"/> F <input checked="" type="checkbox"/> X <input type="checkbox"/>				
Thesis classification: Unclassified <input checked="" type="checkbox"/> Classified <input type="checkbox"/> Level of classification				
Review and Clearance by OASD Required: Yes <input type="checkbox"/> No <input checked="" type="checkbox"/>				
<input type="checkbox"/> Thesis contains proprietary information or is an externally controlled distribution thesis. Therefore, permission of distribution should be obtained from the individuals and companies as listed in blocks 9 and/or 10 of Standard Form 298. It is the Advisor's responsibility to secure permission. The certification below indicates that permission has been secured.				
I certify that the distribution as delineated above is in compliance with the designated distribution statement:				
_____ Signature, Thesis Advisor			_____ Date	
_____ Signature, Chair or Dean			_____ Date	

THESIS RELEASE FORM			
Title:	HOW THE DEGREE OF ACCURACY OF AN INERTIAL MEASUREMENT UNIT (IMU) INFLUENCES THE MISS DISTANCE OF A GUN-LAUNCHED PRECISION MUNITION		Grad Date: Sep 2011
Author(s)	Mr. David W. Panhorst		
Thesis Advisor(s)	Dr. Walter E. Owen, DPA; Dr. Donald E. Carlucci, Ph. D.		
Program Officer (GSEAS and OR Only)	Mr. Joseph W. Sweeney III		
Curric Number: PD-21	Degree: MS <input checked="" type="checkbox"/> MA <input type="checkbox"/> ENG <input type="checkbox"/> MBA <input type="checkbox"/> PhD <input type="checkbox"/>		
Department Chair or Dean:	Dr. Clifford A. Whitcomb, Ph. D.		
APPROVAL FOR PUBLICATION TO THE NPS AND DTIC WEBSITES			
The undersigned certify that to the best of their knowledge, this thesis should be published for unlimited distribution. Criteria for release are: 1) quality is high 2) subject matter is relevant to Navy/DoD/government 3) thesis does not contain (individually or in aggregate with other theses) sensitive, proprietary or classified material.			
Author(s)	Yes <input checked="" type="checkbox"/>	No <input type="checkbox"/>	Signature(s)  Date 8/18/11
Advisor(s)	Yes <input checked="" type="checkbox"/>	No <input type="checkbox"/>	Signature(s)  Date 8/18/11
Program Officer	Yes <input type="checkbox"/>	No <input type="checkbox"/>	Signature (GSEAS and OR only) Date
Chair/Dean	Yes <input type="checkbox"/>	No <input type="checkbox"/>	Signature Date
If "No" is checked above and the student is International, use Distribution Statement F.			
HOLD <input type="checkbox"/>	Reason:		Desired release date:
HUMAN SUBJECTS RESEARCH			
Does this research involve Human Subject Research? Y <input type="checkbox"/> N <input checked="" type="checkbox"/>			
If yes, list protocol number(s) here and in block 11 of Form 298, in thesis			
If yes, have end of experiment report and all supporting documentation, such as informed consent forms, been submitted to the Human Research Protections Office? Y <input type="checkbox"/>			
CERTIFICATION OF ORIGINAL WORK			
The undersigned certifies that the thesis is an original work of the author(s). Work of others has been appropriately cited.			
Signature, Author(s) 			Date 8/18/11
THESIS DISTRIBUTION STATEMENT: In view of the literary quality and technical content of this thesis, and the extent of its self-contained contribution to the field of knowledge, and the potential contribution to the reputation of the Naval Postgraduate School, it is recommended that the distribution of this thesis be as follows:			
Statement (select based on attached questionnaire): A <input checked="" type="checkbox"/> B <input type="checkbox"/> C <input type="checkbox"/> D <input type="checkbox"/> E <input type="checkbox"/> F <input type="checkbox"/> X <input type="checkbox"/>			
Thesis classification: Unclassified <input checked="" type="checkbox"/> Classified <input type="checkbox"/> Level of classification			
Review and Clearance by OASD Required: Yes <input type="checkbox"/> No <input checked="" type="checkbox"/>			
<input type="checkbox"/> Thesis contains proprietary information or is an externally controlled distribution thesis. Therefore, permission of distribution should be obtained from the individuals and companies as listed in blocks 9 and/or 10 of Standard Form 298. It is the Advisor's responsibility to secure permission. The certification below indicates that permission has been secured.			
I certify that the distribution as delineated above is in compliance with the designated distribution statement:			
Signature, Thesis Advisor			Date
Signature, Chair or Dean			Date

**HOW THE DEGREE OF ACCURACY OF AN INERTIAL MEASUREMENT UNIT (IMU)
INFLUENCES THE MISS DISTANCE OF A GUN-LAUNCHED PRECISION MUNITION**

David W. Panhorst

B.S., Pennsylvania State University, August 1982

Master of Science, Management of Technology—May 1997

Advisor: Dr. Walter E. Owen, DPA

Second Reader: Dr. Donald E. Carlucci, Ph. D

Precision Munition projectiles guide to an area to hit their target. The projectile must read position in-flight and measure deviations from the intended flight path. This allows the projectile to correct and maintain the intended trajectory. An Inertial Measurement Unit (IMU) device measures the relative movement of a projectile throughout flight and measures the deviation from the intended path, enabling the projectile to course correct. The purpose of this thesis is to understand the degree to which the precision of the IMU influences the delivery accuracy of a gun-launched munition. This research will model the influences of gyro bias stability and acceleration bias stability and quantify their effects.

KEYWORDS: Precision Munitions, Inertial Measurement Unit, Accuracy, Gun-launched Munition, Bias Stability

john.hedderich@us.army.mil
william.r.smith6@us.army.mil
don.carlucci@us.army.mil
thomas.recchia@us.army.mil
mauricio.guevara@us.army.mil
daniel.r.smith10@us.army.mil



Name: David W. Penhorst
Code: _____

COLOR PAGE PRINT REQUEST (library copies)

If your thesis contains figures and/or tables that require color printing in order to display the data correctly, you may request the pages be printed in color.

When your thesis has been finalized and your signature page has been signed, indicate below which pages are to be printed in color. **(use the numbering from your thesis, not the page numbers generated by the Adobe Acrobat software)**

Bring this page, along with your original signed signature page and your original signed thesis release form to your thesis processor at the final visit.

Cover Page

Pages 14, 15, 19, 20, 21, 28, 29, 30, 31, 32, 33, 34, 35, 37

48 - 74



REPORT DOCUMENTATION PAGE			<i>Form Approved OMB No. 0704-0188</i>
Public reporting burden for this collection of information is estimated to average 1 hour per response, including the time for reviewing instruction, searching existing data sources, gathering and maintaining the data needed, and completing and reviewing the collection of information. Send comments regarding this burden estimate or any other aspect of this collection of information, including suggestions for reducing this burden, to Washington headquarters Services, Directorate for Information Operations and Reports, 1215 Jefferson Davis Highway, Suite 1204, Arlington, VA 22202-4302, and to the Office of Management and Budget, Paperwork Reduction Project (0704-0188) Washington DC 20503.			
1. AGENCY USE ONLY (Leave blank)	2. REPORT DATE September 2011	3. REPORT TYPE AND DATES COVERED Thesis Technical Report	
4. TITLE AND SUBTITLE: An Analysis of Proposed Solutions for a Clandestine Offensive Maritime Mining Capability			5. FUNDING NUMBERS
6. AUTHOR(S) Andrew Blair, Katherine Brackett, Kyle Brown, Matthew Chastain, Zena Le, Dawn Manga, Ivan Pereira, Lori Zipes			
7. PERFORMING ORGANIZATION NAME(S) AND ADDRESS(ES) Naval Postgraduate School Monterey, CA 93943-5000			8. PERFORMING ORGANIZATION REPORT NUMBER NPS-SE-11-009
9. SPONSORING / MONITORING AGENCY NAME(S) AND ADDRESS(ES) N/A			10. SPONSORING/MONITORING AGENCY REPORT NUMBER
11. SUPPLEMENTARY NOTES The views expressed in this report are those of the author and do not reflect the official policy or position of the Department of Defense or the US Government.			
12a. DISTRIBUTION / AVAILABILITY STATEMENT Distribution authorized to the Department of Defense and US DoD contractors only (Critical Technology) (May 2011). Other requests shall be referred to President, Code 261, Naval Postgraduate School, Monterey, CA 93943-5000 via the Defense Technical Information Center, 8725 John J. Kingman Rd., STE 0944, Ft. Belvoir, VA 22060-6128.			12b. DISTRIBUTION CODE
13. ABSTRACT (maximum 200 words) The U.S. Navy's capability to clandestinely place minefields is entirely reliant on the MK 67 Submarine Launched Mobile Mine (SLMM). This capability is scheduled to be removed from service in the near future. In order to keep mining a viable tool for maintaining maritime dominance, the Navy has an immediate need for a clandestine, offensive minefield placement capability. This Capstone project consists of a systems engineering analysis of near-term solutions that could enable the US Navy to retain a viable clandestine delivery system. Potential solutions studied include the use of unmanned underwater vehicles (UUVs) for mine delivery, and Improved SLMMs (ISLMM). All potential solutions were examined for performance, cost, and time for deployment. Individual system architectures and operational concepts were developed when appropriate. The solutions were refined functionally and physically, analyzed with regards to defined Measures of Effectiveness, and a dominant solution emerged. The ISLMM solution exhibits superior performance when compared to the alternate solutions studied, but also has the highest estimated life cycle cost. The results of this study provide a means for making a decision as to which system should be considered for immediate development.			
14. SUBJECT TERMS Clandestine Offensive Maritime Mining, Large Diameter Unmanned Underwater Vehicle, Improved Submarine Launched Mobile Mine			15. NUMBER OF PAGES 292
			16. PRICE CODE
17. SECURITY CLASSIFICATION OF REPORT Unclassified	18. SECURITY CLASSIFICATION OF THIS PAGE Unclassified	19. SECURITY CLASSIFICATION OF ABSTRACT Unclassified	20. LIMITATION OF ABSTRACT UL

NSN 7540-01-280-5500

Standard Form 298 (Rev. 2-89)

Prescribed by ANSI Std. Z39-18

Approved for Public Release – Distribution is Unlimited

**IMPROVING HEALTH CARE DELIVERY FOR POSTTRAUMATIC STRESS
DISORDER: AN INTERRELATED APPROACH LEVERAGING SYSTEMS
ENGINEERING AND OPTIMIZATION**

Scott Alexander McKenzie
Civilian
B.S., Mississippi State University, 2002

Submitted in partial fulfillment of the
requirements for the degree of

MASTER OF SCIENCE IN SYSTEMS ENGINEERING MANAGEMENT

from the

**NAVAL POSTGRADUATE SCHOOL
September 2011**



Author: Scott Alexander McKenzie

Approved by: Douglas MacKinnon, PhD
Thesis Advisor

John Osmundson, PhD
Thesis Co-Advisor

Cliff Whitcomb, PhD
Chair, Department of Systems Engineering

THESIS RELEASE FORM

Title:	Improving Health Care Delivery for Posttraumatic Stress Disorder: An Interrelated Approach Leveraging Systems Engineering and Optimization	Grad Date: Sep 2011
--------	--	---------------------

Author(s)	Scott Alexander McKenzie
-----------	--------------------------

Thesis Advisor(s)	Doug MacKinnon, PhD, John Osmundson, PhD
-------------------	--

Program Officer (GSEAS and OR Only)	N/A Joseph W. Sweeney III
-------------------------------------	--------------------------------------

Curric Number: 721	Degree: MS <input checked="" type="checkbox"/> MA <input type="checkbox"/> ENG <input type="checkbox"/> MBA <input type="checkbox"/> PhD <input type="checkbox"/>
--------------------	---

Department Chair or Dean:	Clifford Whitcomb, PhD
---------------------------	------------------------

APPROVAL FOR PUBLICATION TO THE NPS AND DTIC WEBSITES

The undersigned certify that to the best of their knowledge, this thesis should be published for unlimited distribution. Criteria for release are: 1) quality is high 2) subject matter is relevant to Navy/DoD/government 3) thesis does not contain (individually or in aggregate with other theses) sensitive, proprietary or classified material.

Author(s)	Yes <input checked="" type="checkbox"/> No <input type="checkbox"/>	Signature(s)	<i>Scott McKenzie</i>	Date	8/30/11
Advisor(s)	Yes <input checked="" type="checkbox"/> No <input type="checkbox"/>	Signature(s)		Date	
Program Officer	Yes <input checked="" type="checkbox"/> No <input type="checkbox"/>	Signature (GSEAS and OR only)		Date	
Chair/Dean	Yes <input checked="" type="checkbox"/> No <input type="checkbox"/>	Signature		Date	

If "No" is checked above and the student is International, use Distribution Statement F.

HOLD <input type="checkbox"/>	Reason:	Desired release date:
--------------------------------------	---------	-----------------------

HUMAN SUBJECTS RESEARCH

Does this research involve Human Subject Research? Y N

If yes, list protocol number(s) here and in block 11 of Form 298, in thesis

If yes, have end of experiment report and all supporting documentation, such as informed consent forms, been submitted to the Human Research Protections Office? Y

CERTIFICATION OF ORIGINAL WORK

The undersigned certifies that the thesis is an original work of the author(s). Work of others has been appropriately cited.

Scott McKenzie
Signature, Author(s)

8/30/11
Date

THESIS DISTRIBUTION STATEMENT: In view of the literary quality and technical content of this thesis, and the extent of its self-contained contribution to the field of knowledge, and the potential contribution to the reputation of the Naval Postgraduate School, it is recommended that the distribution of this thesis be as follows:

Statement (select based on attached questionnaire): A B C D E F X

Thesis classification: Unclassified Classified Level of classification

Review and Clearance by OASD Required: Yes No

Thesis contains proprietary information or is an externally controlled distribution thesis. Therefore, permission of distribution should be obtained from the individuals and companies as listed in blocks 9 and/or 10 of Standard Form 298. It is the Advisor's responsibility to secure permission. The certification below indicates that permission has been secured.

I certify that the distribution as delineated above is in compliance with the designated distribution statement:

Signature, Thesis Advisor _____
Date

Signature, Chair or Dean _____
Date

Unclassified, Limited Distribution

**A systems engineering trade-off analysis method to assess the value of
alternatives that do not meet all requirements**

Kenneth A. Bogdan
Civilian, Department of the Navy
B.S., US Naval Academy, 1986
M.S., The Catholic University of America, 1987
M.S., Florida Institute of Technology, 1993

Submitted in partial fulfillment of the
requirements for the degree of

MASTER OF SCIENCE IN SYSTEMS ENGINEERING

from the

**NAVAL POSTGRADUATE SCHOOL
September 2011**

Author: 
Kenneth A. Bogdan

Approved by: Paul R. Montgomery, D.Sc.
Thesis Advisor

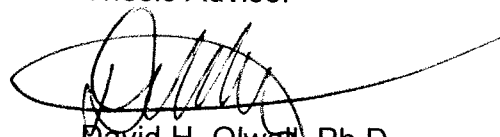
David H. Olwell, Ph.D.
Thesis Co-Advisor

Clifford A. Whitcomb, Ph.D.
Chairman, Department of Systems Engineering

THESIS RELEASE FORM

Title: A systems engineering trade-off analysis to assess the value of alternative that do not meet requirements Grad Date: Sep 2011

Author(s) Kenneth A. Bogdan

Thesis Advisor(s) Paul R. Montgomery D.Sc., David U. O'Neill Ph.D.

Program Officer (GSEAS and OR Only) Joseph W. Sweeney II

Curric Number: Degree: MS MA ENG MBA PhD

Department Chair or Dean: Clifford A. Whitcomb, Ph.D.

APPROVAL FOR PUBLICATION TO THE NPS AND DTIC WEBSITES

The undersigned certify that to the best of their knowledge, this thesis should be published for unlimited distribution. Criteria for release are: 1) quality is high 2) subject matter is relevant to Navy/DoD/government 3) thesis does not contain (individually or in aggregate with other theses) sensitive, proprietary or classified material.

Author(s)	Yes <input checked="" type="checkbox"/>	No <input type="checkbox"/>	Signature(s) <u>Kenneth A. Bogdan</u>	Date <u>9/19/2011</u>
Advisor(s)	Yes <input type="checkbox"/>	No <input type="checkbox"/>	Signature(s)	Date
Program Officer	Yes <input type="checkbox"/>	No <input type="checkbox"/>	Signature (GSEAS and OR only)	Date
Chair/Dean	Yes <input type="checkbox"/>	No <input type="checkbox"/>	Signature	Date

If "No" is checked above and the student is International, use Distribution Statement F.

HOLD Reason: _____ Desired release date: _____

HUMAN SUBJECTS RESEARCH

Does this research involve Human Subject Research? Y N

If yes, list protocol number(s) here and in block 11 of Form 298, in thesis _____

If yes, have end of experiment report and all supporting documentation, such as informed consent forms, been submitted to the Human Research Protections Office? Y

CERTIFICATION OF ORIGINAL WORK

The undersigned certifies that the thesis is an original work of the author(s). Work of others has been appropriately cited.

Kenneth A. Bogdan
Signature, Author(s)

7/17/2011
Date

THESIS DISTRIBUTION STATEMENT: In view of the literary quality and technical content of this thesis, and the extent of its self-contained contribution to the field of knowledge, and the potential contribution to the reputation of the Naval Postgraduate School, it is recommended that the distribution of this thesis be as follows:

Statement (select based on attached questionnaire): A B C D E F X

Thesis classification: Unclassified Classified Level of classification _____

Review and Clearance by OASD Required: Yes No

Thesis contains proprietary information or is an externally controlled distribution thesis. Therefore, permission of distribution should be obtained from the individuals and companies as listed in blocks 9 and/or 10 of Standard Form 298. It is the Advisor's responsibility to secure permission. The certification below indicates that permission has been secured.

I certify that the distribution as delineated above is in compliance with the designated distribution statement:

Signature, Thesis Advisor

Date

Signature, Chair or Dean

Date

Approved for public release; distribution is unlimited

**A SOFTWARE ASSURANCE FRAMEWORK FOR MITIGATING THE RISKS
OF MALICIOUS SOFTWARE IN EMBEDDED SYSTEMS USED IN AIRCRAFT**

Robert C. Ginn
Civilian, United States Navy
B.S., Lehigh University, 1983
M.S., Penn State University, 1992

Submitted in partial fulfillment of the
requirements for the degree of

MASTER OF SCIENCE IN SYSTEMS ENGINEERING

from the

**NAVAL POSTGRADUATE SCHOOL
September 2011**

Author:



Robert Ginn

Approved by:



John Osmundson, PhD



Janet Gill, PhD



Clifford Whitcomb, PhD

Chair, Department of Systems Engineering

THESIS RELEASE FORM

Title:	A SOFTWARE ASSURANCE FRAMEWORK FOR MITIGATING THE RISKS OF MALICIOUS SOFTWARE IN EMBEDDED SYSTEMS USED IN AIRCRAFT	Grad Date: Sep 2011
--------	--	---------------------

Author(s)	Robert Ginn
-----------	-------------

Thesis Advisor(s)	John Osmundson, Ph.D., Janet Gill, Ph.D.
-------------------	--

Program Officer (GSEAS and OR Only)	
-------------------------------------	--

Curric Number: 721	Degree: MS <input checked="" type="checkbox"/> MA <input type="checkbox"/> ENG <input type="checkbox"/> MBA <input type="checkbox"/> PhD <input type="checkbox"/>
--------------------	---

Department Chair or Dean:	Clifford Whitcomb, Ph.D.
---------------------------	--------------------------

APPROVAL FOR PUBLICATION TO THE NPS AND DTIC WEBSITES
 The undersigned certify that to the best of their knowledge, this thesis should be published for unlimited distribution. Criteria for release are: 1) quality is high 2) subject matter is relevant to Navy/DoD/government 3) thesis does not contain (individually or in aggregate with other theses) sensitive, proprietary or classified material.

Author(s)	Yes <input checked="" type="checkbox"/> No <input type="checkbox"/>	Signature(s)	<i>Robert Ginn</i>	Date	9/6/2011
-----------	---	--------------	--------------------	------	----------

Advisor(s)	Yes <input checked="" type="checkbox"/> No <input type="checkbox"/>	Signature(s)	<i>John Osmundson</i>	Date	9/22/2011
------------	---	--------------	-----------------------	------	-----------

Program Officer	Yes <input type="checkbox"/> No <input type="checkbox"/>	Signature (GSEAS and OR only)		Date	
-----------------	--	-------------------------------	--	------	--

Chair/Dean	Yes <input checked="" type="checkbox"/> No <input type="checkbox"/>	Signature	<i>Clifford Whitcomb</i>	Date	9/23/11
------------	---	-----------	--------------------------	------	---------

If "No" is checked above and the student is International, use Distribution Statement F.

HOLD <input type="checkbox"/>	Reason:	Desired release date:
--------------------------------------	---------	-----------------------

HUMAN SUBJECTS RESEARCH
 Does this research involve Human Subject Research? Y N
 If yes, list protocol number(s) here and in block 11 of Form 298, in thesis
 If yes, have end of experiment report and all supporting documentation, such as informed consent forms, been submitted to the Human Research Protections Office? Y

CERTIFICATION OF ORIGINAL WORK
 The undersigned certifies that the thesis is an original work of the author(s). Work of others has been appropriately cited.

<i>Robert Ginn</i>	9/6/2011
Signature, Author(s)	Date

THESIS DISTRIBUTION STATEMENT: In view of the literary quality and technical content of this thesis, and the extent of its self-contained contribution to the field of knowledge, and the potential contribution to the reputation of the Naval Postgraduate School, it is recommended that the distribution of this thesis be as follows:

Statement (select based on attached questionnaire): A B C D E F X



Thesis classification: Unclassified Classified Level of classification

Review and Clearance by OASD Required: Yes No

Thesis contains proprietary information or is an externally controlled distribution thesis. Therefore, permission of distribution should be obtained from the individuals and companies as listed in blocks 9 and/or 10 of Standard Form 298. It is the Advisor's responsibility to secure permission. The certification below indicates that permission has been secured.

I certify that the distribution as delineated above is in compliance with the designated distribution statement:

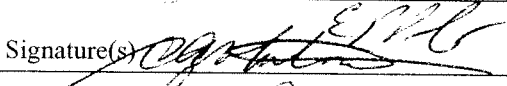
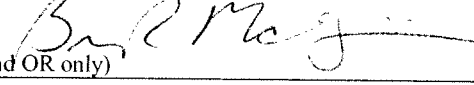
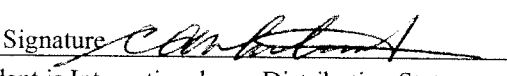
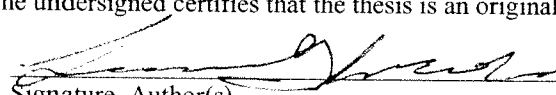
<i>John Osmundson</i>	9/22/2011
Signature, Thesis Advisor	Date
<i>Clifford Whitcomb</i>	9/23/11
Signature, Chair or Dean	Date

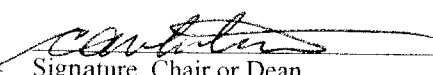
THESIS RELEASE FORM			
Title:	INVESTIGATING THE LINK BETWEEN COMBAT SYSTEM CAPABILITY AND SHIP DESIGN		Grad Date: Sep 2011
Author(s)	Savannah Gill Welch		
Thesis Advisor(s)	Clifford Whitcomb		
Program Officer (GSEAS and OR Only)	Captain Brian McGinnis		
Curric Number: 580	Degree: MS <input checked="" type="checkbox"/> MA <input type="checkbox"/> ENG <input type="checkbox"/> MBA <input type="checkbox"/> PhD <input type="checkbox"/>		
Department Chair or Dean:	Clifford Whitcomb		
APPROVAL FOR PUBLICATION TO THE NPS AND DTIC WEBSITES			
The undersigned certify that to the best of their knowledge, this thesis should be published for unlimited distribution. Criteria for release are: 1) quality is high 2) subject matter is relevant to Navy/DoD/government 3) thesis does not contain (individually or in aggregate with other theses) sensitive, proprietary or classified material.			
Author(s)	Yes <input checked="" type="checkbox"/> No <input type="checkbox"/>	Signature(s) 	Date 9/15/11
Advisor(s)	Yes <input checked="" type="checkbox"/> No <input type="checkbox"/>	Signature(s) 	Date 9/15/11
Program Officer	Yes <input checked="" type="checkbox"/> No <input type="checkbox"/>	Signature (GSEAS and OR only) 	Date 15 SEP 11
Chair/Dean	Yes <input checked="" type="checkbox"/> No <input type="checkbox"/>	Signature 	Date 9/15/11
If "No" is checked above and the student is International, use Distribution Statement F.			
HOLD <input type="checkbox"/>	Reason:	Desired release date:	
HUMAN SUBJECTS RESEARCH			
Does this research involve Human Subject Research? Y <input type="checkbox"/> N <input checked="" type="checkbox"/>			
If yes, list protocol number(s) here and in block 11 of Form 298, in thesis			
If yes, have end of experiment report and all supporting documentation, such as informed consent forms, been submitted to the Human Research Protections Office? Y <input type="checkbox"/>			
CERTIFICATION OF ORIGINAL WORK			
The undersigned certifies that the thesis is an original work of the author(s). Work of others has been appropriately cited.			
Signature, Author(s) 			Date 9/15/11
THESIS DISTRIBUTION STATEMENT: In view of the literary quality and technical content of this thesis, and the extent of its self-contained contribution to the field of knowledge, and the potential contribution to the reputation of the Naval Postgraduate School, it is recommended that the distribution of this thesis be as follows:			
Statement (select based on attached questionnaire): A <input checked="" type="checkbox"/> B <input type="checkbox"/> C <input type="checkbox"/> D <input type="checkbox"/> E <input type="checkbox"/> F <input type="checkbox"/> X <input type="checkbox"/>			
Thesis classification: Unclassified <input checked="" type="checkbox"/> Classified <input type="checkbox"/> Level of classification			
Review and Clearance by OASD Required: Yes <input type="checkbox"/> No <input checked="" type="checkbox"/>			
<input type="checkbox"/> Thesis contains proprietary information or is an externally controlled distribution thesis. Therefore, permission of distribution should be obtained from the individuals and companies as listed in blocks 9 and/or 10 of Standard Form 298. It is the Advisor's responsibility to secure permission. The certification below indicates that permission has been secured.			
I certify that the distribution as delineated above is in compliance with the designated distribution statement:			
Signature, Thesis Advisor 			Date 9/15/11
Signature, Chair or Dean 			Date 9/15/11

Approved for public release; distribution is unlimited

**INVESTIGATING THE LINK BETWEEN COMBAT SYSTEM CAPABILITY
AND SHIP DESIGN**

Savannah G. Welch
Lieutenant, United States Navy
B.S., Vanderbilt University, 2007

Submitted in partial fulfillment of the
requirements for the degree of

MASTER OF SCIENCE IN SYSTEMS ENGINEERING

from the

**NAVAL POSTGRADUATE SCHOOL
September 2011**

Author:

Savannah G. Welch

Approved by:

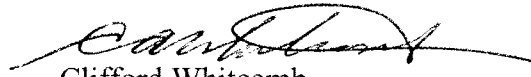
Clifford Whitcomb
Thesis Advisor

Eugene Paulo
Second Reader

Clifford Whitcomb
Chair, Department of Systems Engineering