



AFRL-RX-TY-TR-2012-0007

RESEARCH AND DEVELOPMENT FOR ROBOTIC TRANSPORTABLE WASTE TO ENERGY SYSTEM (TWES)

Christopher A. Lindsey, James T. Olmsted, Clair H. Hessmer,
Sara B. Aaserud and Anneliese M. Schmidt
Antares Group, Incorporated
4351 Garden City Drive, Suite 301
Landover, MD 20785

Thomas A. Bowen
Airbase Technologies Division
Air Force Research Laboratory
139 Barnes Drive, Suite 2
Tyndall Air Force Base, FL 32403-5323

Contract No. FA4819-08-C-0007

January 2012

DISTRIBUTION A: Approved for public release, distribution unlimited.
88ABW-2012-2561, 1 May 2012.

**AIR FORCE RESEARCH LABORATORY
MATERIALS AND MANUFACTURING DIRECTORATE**

DISCLAIMER

Reference herein to any specific commercial product, process, or service by trade name, trademark, manufacturer, or otherwise does not constitute or imply its endorsement, recommendation, or approval by the United States Air Force. The views and opinions of authors expressed herein do not necessarily state or reflect those of the United States Air Force.

This report was prepared as an account of work sponsored by the United States Air Force. Neither the United States Air Force, nor any of its employees, makes any warranty, expressed or implied, or assumes any legal liability or responsibility for the accuracy, completeness, or usefulness of any information, apparatus, product, or process disclosed, or represents that its use would not infringe privately owned rights.

NOTICE AND SIGNATURE PAGE

Using Government drawings, specifications, or other data included in this document for any purpose other than Government procurement does not in any way obligate the U.S. Government. The fact that the Government formulated or supplied the drawings, specifications, or other data does not license the holder or any other person or corporation; or convey any rights or permission to manufacture, use, or sell any patented invention that may relate to them.

This report was cleared for public release by the 88th Air Base Wing Public Affairs Office at Wright Patterson Air Force Base, Ohio available to the general public, including foreign nationals. Copies may be obtained from the Defense Technical Information Center (DTIC) (<http://www.dtic.mil>).

AFRL-RX-TY-TR-2012-0007 HAS BEEN REVIEWED AND IS APPROVED FOR PUBLICATION IN ACCORDANCE WITH ASSIGNED DISTRIBUTION STATEMENT.

BOWEN.THOMAS.A
RTHUR.1291059569

Digitally signed by
BOWEN.THOMAS.ARTHUR.1291059569
DN: c=US, o=U.S. Government, ou=DoD, ou=PKI,
ou=USAF, cn=BOWEN.THOMAS.ARTHUR.1291059569
Date: 2012.04.03 09:23:32 -0500

THOMAS A. BOWEN, 2nd Lt, USAF
Work Unit Manager

WALKER.KRYSTAL
.MARIE.1123581462

Digitally signed by WALKER.KRYSTAL.MARIE.1123581462
DN: c=US, o=U.S. Government, ou=DoD, ou=PKI,
ou=USAF, cn=WALKER.KRYSTAL.MARIE.1123581462
Date: 2012.04.03 12:42:13 -0500

KRYSTAL M. WALKER, Captain, USAF
Chief, Airbase Engineering Development
Branch

RHODES.ALBERT
.N.III.1175488622

Digitally signed by
RHODES.ALBERT.N.III.1175488622
DN: c=US, o=U.S. Government, ou=DoD, ou=PKI,
ou=USAF, cn=RHODES.ALBERT.N.III.1175488622
Date: 2012.04.25 15:23:57 -0500

ALBERT N. RHODES, PhD
Chief, Airbase Technologies Division

This report is published in the interest of scientific and technical information exchange, and its publication does not constitute the Government's approval or disapproval of its ideas or findings.

REPORT DOCUMENTATION PAGE

*Form Approved
OMB No. 0704-0188*

The public reporting burden for this collection of information is estimated to average 1 hour per response, including the time for reviewing instructions, searching existing data sources, gathering and maintaining the data needed, and completing and reviewing the collection of information. Send comments regarding this burden estimate or any other aspect of this collection of information, including suggestions for reducing the burden, to Department of Defense, Washington Headquarters Services, Directorate for Information Operations and Reports (0704-0188), 1215 Jefferson Davis Highway, Suite 1204, Arlington, VA 22202-4302. Respondents should be aware that notwithstanding any other provision of law, no person shall be subject to any penalty for failing to comply with a collection of information if it does not display a currently valid OMB control number.

PLEASE DO NOT RETURN YOUR FORM TO THE ABOVE ADDRESS.

1. REPORT DATE (DD-MM-YYYY) 23-JAN-2012	2. REPORT TYPE Final Technical Report	3. DATES COVERED (From - To) 24-SEP-2008 -- 30-DEC-2011
---	---	---

4. TITLE AND SUBTITLE Research and Development for Robotic Transportable Waste to Energy System (TWES)	5a. CONTRACT NUMBER FA4819-08-C-0007
	5b. GRANT NUMBER
	5c. PROGRAM ELEMENT NUMBER 0909999F

6. AUTHOR(S) ^Lindsey, Christopher A.; ^Olmsted, James T.; ^Hessmer, Clair H.; ^Aaserud, Sara B.; ^Schmidt, Anneliese M.; *Bowen, Thomas A.	5d. PROJECT NUMBER GOVT
	5e. TASK NUMBER D0
	5f. WORK UNIT NUMBER QF503016

7. PERFORMING ORGANIZATION NAME(S) AND ADDRESS(ES) ^Antares Group, Incorporated 4351 Garden City Drive, Suite 301 Landover, MD 20785	8. PERFORMING ORGANIZATION REPORT NUMBER
--	---

9. SPONSORING/MONITORING AGENCY NAME(S) AND ADDRESS(ES) *Air Force Research Laboratory Materials and Manufacturing Directorate Airbase Technologies Division 139 Barnes Drive, Suite 2 Tyndall Air Force Base, FL 32403-5323	10. SPONSOR/MONITOR'S ACRONYM(S) AFRL/RXQES
	11. SPONSOR/MONITOR'S REPORT NUMBER(S) AFRL-RX-TY-TR-2012-0007

12. DISTRIBUTION/AVAILABILITY STATEMENT
Distribution A: Approved for public release; distribution unlimited.

13. SUPPLEMENTARY NOTES
Ref Public Affairs Case # 88ABW-2012-2561, 1 May 2012. Document contains color images.

14. ABSTRACT
The TWES is designed to trigenerate electricity, chilled water and steam by burning waste. The system processes mixed refuse, burns it completely in a novel furnace, vents the flue gas through a steam generator from which steam will run an organic rankine cycle generator and an absorption chiller before being routed back to the steam generator. Emissions testing demonstrates the system is orders of magnitude below the Florida Environmental Protection Agency's emissions limits. The system of three trailers would be a deployable asset to alleviate some of the need for trash removal and diesel to run electric generators. TWES could have a profound effect on base security by potentially eliminating the need for third country national access to the base for waste pickup. TWES could also alleviate the strain placed on local landfills, both deployed and CONUS alike. Since humans will always produce waste, it is the epitome of renewable energy systems.

15. SUBJECT TERMS
Transportable waste to energy, waste reduction, electric generation, UXO disposal, biohazard disposal, renewable energy, green

16. SECURITY CLASSIFICATION OF:			17. LIMITATION OF ABSTRACT UU	18. NUMBER OF PAGES 99	19a. NAME OF RESPONSIBLE PERSON Thomas Bowen
a. REPORT U	b. ABSTRACT U	c. THIS PAGE U			19b. TELEPHONE NUMBER (Include area code) 850-283-3725

Reset

TABLE OF CONTENTS

LIST OF FIGURES	ii
LIST OF TABLES	ii
1. SUMMARY	1
2. INTRODUCTION	4
3. METHODS, ASSUMPTIONS, AND PROCEDURES	6
3.1. Methodology	6
3.2. Assumptions.....	6
3.3. Procedures	7
3.3.1. Summary of Observations and Activities During Testing.....	8
4. RESULTS AND DISCUSSION	10
4.1. Temperature Readings	10
4.2. Pressure Readings	13
4.3. Steam Generation.....	15
4.4. Analysis.....	22
4.4.1. Variance of Results	23
5. CONCLUSIONS.....	27
6. RECOMMENDATIONS	28
7. REFERENCES	29
Appendix A: AutoCAD Drawings	30
Appendix B: Annotated Punch List	34
Appendix C: Index of Submittals	38
Appendix D: Original ANTARES Data Collection Plan.....	41
Appendix E: Additional Test Data	47
Appendix F: AFRL Test Plan.....	51
LIST OF SYMBOLS, ABBREVIATIONS, AND ACRONYMS	96

LIST OF FIGURES

	Page
Figure 1. Temperature Profiles during Testing on December 12, 2011	11
Figure 2. Temperature Profiles during Testing on December 13, 2011	12
Figure 3. Temperature Profiles during Testing on December 15, 2011	13
Figure 4. Three-Phase Power Signal to Trailer on December 12, 2011	14
Figure 5. System Power Demand during Testing Period.....	15
Figure 6. Steam Property Profiles during Testing	16
Figure 7. Key State Points	18
Figure 8. Graphical Heat and Mass Balance—Full Load Biomass Simulation.....	19
Figure 9. Spreadsheet-Based Heat and Mass Balance—Diesel Operation at 5:00 p.m., December 15	20
Figure 10. Uninsulated Combustion Coil Inlet	24
Figure 11. Demand Profile—December 15	26

LIST OF TABLES

	Page
Table 1. Furnace Operational Hours During Test Period	9
Table 2. Instantaneous Measured Conditions at Key State Points—December 15, 5:00 p.m.	21
Table 3. System Efficiency Summary—December 15, 7:39 a.m. to 5:00 p.m.....	23

1. SUMMARY

The Antares Group Inc. (ANTARES) and the Air Force Research Laboratory (AFRL) have continued the development of a Transportable Waste to Energy System (TWES) for the trigeneration of electricity, chilled water, and steam for use in an adjacent building. The system would be mounted on three separate flatbed trailers for transportability. Trailer one for fuel processing, trailer two for combustion and steam generation, and trailer three for electricity production and absorption chilling. The system, had been previously designed and engineered, but only the first trailer had been built.[1] This report covers the construction, testing and analysis of trailer two. The trigeneration equipment has the potential to significantly reduce energy import requirements for heating, cooling, and electrical demands.

More investment in the project is required to fully develop the TWES for remote base application. The rationale for continued investment is to displace electric energy provided by on-site generators fueled with diesel. The TWES can also provide heat (via steam or heating water) and chilled water which could increase the energy independence of a variety of military installations, especially for those remote bases deployed in the field, while at the same time reducing waste disposal problems. For those remote bases, the TWES coupled with other energy conservation and renewable distributed generation technologies could reduce/eliminate demand for diesel fuel in on-site generators fueled with diesel.

The work presented in the main body of the report is the results of the performance testing for the second trailer of the TWES that was conducted the week of December 12, 2011 at the AFRL complex at Tyndall AFB. The second trailer (also referred to as Trailer #2) houses a heat recovery steam generation (HRSG) system that will use the hot flue gas from the furnace to create a maximum of 2,100 lb/hr of 250 psig saturated steam.¹ This system is designed to eventually feed steam to steam piston engine generators and to a hot water heat exchanger that will in turn feed hot water to absorption chillers and for building heating. The piston engines and chillers are to be installed as part of a later project phase, though the complete, four-trailer, intended trigeneration system was conceptually designed and specified as part of the Phase I activity period.

The key methods, assumptions, procedures from the performance testing include:

- The system was tested in an open-loop, steam venting configuration under manual control using the diesel start up burner as the sole source of heat for the furnace that was moved to Trailer #2. Shredded wood chips were planned to be the fuel for testing during this phase of the project. However, to keep costs within budget, the diesel start-up burner was utilized for this test. The diesel burner, while effective, was estimated to provide only 80% of the design heat input to the HRSG.
- Data was collected using a combination of portable data loggers, portable test equipment, installed meters, and manual reads for water levels, fuel levels and steam pressures. Specific information on the data collection plan can be found in the Appendix.
- The system was operated primarily during normal business hours for AFRL of 7:30 a.m. to 3:30 p.m.. The diesel burner was shut down at the end of the day and the thermal

¹ Note that the HRSG vessel is rated to 300 psig, but the maximum design operating pressure is 250 psig.

energy developed in the system was released to the atmosphere overnight. The detailed procedures for Test Plan can be found in Appendix F.

- The TWES required thermal energy input to get the equipment up to temperature. It was assumed that this additional energy was required only during the period between cold startup and when the system started generating steam. Specific assumptions about the calculation methods and the analytical methods are discussed in detail within the report.

As stated in the Test Plan (Appendix F), the goal of the testing was to confirm that “the TWES furnace and steam generator are able to produce any steam as identified visually via the steam vents (threshold 1), 240 lb/hr at 250 psig at 205 °C (threshold 2) and 480 lb/hr (objective),” (Bowen, 2011 p. 3). A further operation goal was to have an overall conversion efficiency of at least 50%.

During testing, the TWES operated stably and achieved a 34.3% probable average net fuel-to-steam efficiency (higher heating value [HHV]² basis) while firing diesel fuel. Based on simulation of full-load biomass operation, the diesel-fueled test was expected to demonstrate a 75% net fuel-to-steam efficiency. All equipment with the exception of instrumentation and pressure reducing valve (PRV) appeared to operate as designed by ANTARES, though the system was not run for long enough to reach steady-state conditions at 250 psig. Energy required to bring the system up to steaming temperature and probable additional heat loss from the furnace both contributed to a lower-than-anticipated efficiency, though the HRSG did appear to operate at 85% efficiency based on flue gas entering and leaving temperatures.

After participating in the testing and performance benchmarking, the following near term actions are recommended:

- Complete the construction on Trailer 2, which should be limited to integrating the controls on Trailer 2 with those on Trailer 1, calibrating data acquisition devices, and repairing the PRV.
- Perform functional test on both Trailers 1 and 2 using biomass, which can serve as a basis for commissioning the controls and data acquisition system.
- Obtain a high temperature anemometer (range up to 500 °C) to insert in flue gas stack of the HRSG. Analyze data collected during functional tests and confirm that the HRSG operates with an 80+% efficiency.

In addition, the following longer term actions are also recommended:

- Procure and install steam piston engine(s) for Trailer 2. These engines can generate up to 45 kW and offset some of the electric demand for the equipment on Trailer 1 and 2.
- Integrate the hot water loop and construct Trailer 3, which will provide a closed loop operation for the TWES. This would increase the Trailer 2 steam generation plant efficiency by an estimated 2–4% (depending on operating steam pressure) by substantially reducing the parasitic load to preheat makeup water.

² Higher heating value refers to the amount of energy released per unit of fuel when the water vapor produced by combustion is condensed—the maximum available energy. In contrast, lower heating value (LHV) refers to the amount of energy available for the fuel when the water vapor remains gaseous, leaving some energy unrecoverable.

- Design and construct the chilled water loop, which will reside on Trailer 4. Based on preliminary heat and mass balance modeling, this could generate over 100 tons of refrigeration in the form of chilled water.
- Re-design furnace to automatically remove ash generated during biomass combustion
- Perform functional testing of four trailer configuration with mixed waste fuel sources
- Deploy TWES trailers to a relevant application

2. INTRODUCTION

This report describes the development of a TWES under contract number FA4819-08-C-0007 issued September 24, 2008. ANTARES was contracted to build upon previous research efforts by AFRL.

AFRL had previously engineered and constructed a trailer-mounted combustion unit demonstrated to produce hot flue gas from biomass fuels using a furnace. This first unit (Trailer #1) was designed to be part of a multi-trailer mobile system that would trigenerate steam, electricity, and chilled water for use in adjacent buildings. The use of biomass in this unit was intended to reduce consumption of fuel oil, diesel, natural gas, gasoline and other high-cost fuels that are particularly vulnerable to supply disruption.

While the idea of the trigeneration system had been conceived, only Trailer #1 had been engineered in detail, specified, and constructed. The project described here was to provide specifications for and oversee the construction, delivery, and commissioning of a steam and hot water generation system (mounted on a trailer), electrical generator and chilled water system (mounted on a separate trailer). These trailers (Trailer #2 for the steam generation system and Trailer #3 for the electricity and chilled water generation) were to be compatible with the existing trailer containing the experimental combustor/furnace system. The integration of the existing and new systems would allow combustible base wastes to be used as a fuel for the production of hot flue gas that would subsequently generate 250 psig, 405 °F (207 °C) steam in a HRSG. This steam would be converted to hot water for either space heating or driving an absorption chiller for chilled water generation, and steam engine generator sets would be used for electricity production. The hot water, electricity, and chilled water could all be supplied to an adjacent building.

The design of the additional trailer(s) used as much off-the-shelf technology as possible to reduce the technical risk of AFRL's novel arrangement. Three phases of work were planned:

- Phase I—Installation and testing of the steam/hot water generation system, including:
 - Completion of a final set of specification for the entire system's construction, including all interconnections, the steam/hot water generation system, the electrical generators, and the chilled water system.
 - Procurement of equipment and materials for the steam/hot water generation system, including a trailer on which to mount equipment.
 - Construction of the trailer-mounted steam/hot water generation system.
 - Design and implementation of an interconnect between the existing and the new trailers.
 - Commission and test (including performance benchmarking) the integrated system on location at Tyndall AFB.
- Phase II—Installation and testing of the electrical generating system, including:
 - Procurement of equipment and materials for the electrical generation system, including steam engines, a condenser, and a trailer on which to mount equipment.
 - Performance modeling of the electrical generating system.
 - Construction of the trailer-mounted electrical generation system.

- Design and implementation of an interconnect between the existing, Phase I and Phase II trailers.
- Design and implementation of electrical feedback systems to connect the trailer to the electrical systems of an adjacent host building.
- Commission and test (including performance benchmarking at part loads) the integrated system on location at Tyndall AFB.
- Phase III—Installation and testing of the chilled water system, including:
 - Procurement of equipment and materials for the chilled water system, including an absorption chiller and a trailer on which to mount equipment.
 - Performance modeling of the chilled water system.
 - Construction of the trailer-mounted chilled water system.
 - Design and implementation of an interconnect between the existing, Phase I, Phase II, and Phase III trailers.
 - Design and implementation of an interconnect between the new trailer and the steam and chilled water systems of an adjacent host building.
 - Commission and test (including performance benchmarking at part loads) the integrated system on location at Tyndall AFB.

This report describes the performance testing for Phase I that was conducted at Tyndall AFB in December of 2011. The following section describes the methods, assumptions, and procedures used during the performance testing.

3. METHODS, ASSUMPTIONS, AND PROCEDURES

This section discusses the testing and analysis effort including the methodology, assumptions, and procedures.

The purpose of the test was to gather data on the performance of the steam generation portion of the TWES system. Although diesel fuel was used in the combustor for the test, the hot flue gas was expected to generate steam in the same manner as if biomass fuel were combusted in the furnace. The key items planned to be calculated were the energy input and energy output of the steam generation process, in order to estimate the total system efficiency. The data points used to calculate those key items are described below along with how the data was logged during the testing. Additional information about the original data collection plan (prepared by ANTARES) and the final data collection plan (prepared by AFRL) are provided in Appendix D and Appendix F, respectively.

3.1. Methodology

For this performance testing, the furnace was fired with No. 2 fuel oil via an auxiliary burner in order to generate steam at a variety of firing rates and pressures. The Beckett CF1400 auxiliary burner has a heat output capacity approximately 80% that of the solid biomass fuel, so peak steaming capacity was not possible. Shredded wood chips were planned to be the fuel for testing during this phase of the project. However, to keep costs within budget, the diesel start-up burner was utilized for this test. The burner firing rate was adjusted to maintain a furnace exit temperature of 1040 °C to limit potential damage to the furnace's internal components. Data was recorded from all available meters and gages at 15-min intervals.

During the post-testing data analysis, data was visually screened for outliers and compared with standard steam properties data to identify any unreasonable values. It was also screened for internal consistency, such as for agreement of steam temperatures and pressures for the same saturated steam stream. Other comparative values used in data evaluation included vendor-issued specifications, equipment dimensions, and predicted heat and mass flows from modeling performed with Thermoflex simulation software. Any data determined to be invalid was excluded from the analysis and clearly identified as such.

3.2. Assumptions

The testing deviated from design operating conditions in several ways:

- As noted above, this testing utilized diesel fuel. The diesel burner, while effective, was estimated to provide only 80% of the design heat input to the HRSG. It was assumed that the blower could handle the static pressure losses in the system. AFRL contacted Beckett, the burner manufacturer, to confirm.
- Without hot water supplied to the air cooler by the as yet unconstructed Trailer #3, steam could not be condensed without a heat sink and returned to the condensate tank. Accordingly, the system was operated in an open-loop configuration with most of the steam produced vented to atmosphere and a 100% makeup water rate based on the net steam generation (which is the gross steam generation less the boiler blowdown and

sparger flow rates). Some steam was diverted to the sparging tank for feedwater preheating.

- AFRL chose not to integrate the Allen Bradley PLC installed on Trailer #2 with the pre-existing controls on Trailer #1. Instead, the system was managed by visual observation and manual valve control.

During the post-testing data analysis, several assumptions were made, including:

- Power factor of 0.8 for measured electrical inputs. In the absence of power metering, this value was used as representative of the small induction motor on the feedwater pump.
- Complete combustion of diesel fuel. As will be discussed in the results section, this may or may not be an accurate assessment.
- Diesel fuel HHV of 140,000 Btu/gal and density of 7.2 lb/gal.
- The diesel burner was assumed to start firing at 7:39 am on December 15.
- The HRSG was assumed to reach steaming temperature at 10:26 am on December 15 as it was the first time that the recorded boiler water level dropped from the previous recorded time by AFRL.
- The HRSG did not increase the steam pressure from 0 psig until 12:45 p.m. as recorded by AFRL, which was assumed to be attributed to the bypass valve being too wide open.
- The makeup water readings by the water meter are too low and cannot be relied upon for the analysis. On December 14, the boiler was drained and refilled. According to Hurst Boiler, the normal water level for the HRSG is approximately 647 gal and the water meter only showed a change of 376 gal (2618 gal read at 3:20 p.m. on December 13 and 2994 gal read at 7:39 am on December 15).

3.3. Procedures

The data collection plan included measurement of the temperature, flow, and pressure at several points within the steam system using instruments already installed on the trailer as well as some additional instruments and data loggers. The major equipment on Trailer #2 included:

- HRSG - Single-pass fire-tube heat recovery boiler manufactured by Hurst, with a rated capacity of 63.5 bhp. The maximum design operating pressure is 250 psig, although the vessel is rated for 300 psig.
- Feedmiser package - 100-gal duplex Feedmiser package, including two hp Grundfos pumps rated to 15 gpm at 602 ft of head and a 100-gal tank

The trailer equipment also included flue gas ducting, blowdown equipment, steam and condensate piping, valves and fitting, and wiring and control systems. During the test, the water treatment system was not used to reduce costs; well water was run directly to the feedwater pumps. AFRL reported that Hurst, the HRSG manufacturer, was contacted and that it approved of this practice for a system not in continuous use.

Test data was collected with 4-channel Onset Hobo data loggers and pulsed-output 4–20 mA instruments on a 15-s interval, with visual observation and manual recording for redundancy. This allowed a fine time interval and minimized error in gauge reading and data entry. More information regarding the equipment and planned protocol is available in the original data collection plan in Appendix D, as well as the AFRL final test plan provided in Appendix F. Data

loggers and sensors were installed in a slightly modified pattern to accommodate the available operable instrumentation.

The following data were collected and checked for consistency against the existing gauges:

- The existing steam flow meter was used in combination with a data logger to record medium-pressure steam flow rates. In order to correctly account for accumulation of water in the system, water level readings were also manually recorded for the HRSG and feedwater tank upon startup and shutdown of the system.
- Medium- and low-pressure steam pressures were logged with the output from existing pressure transducers and a data logger, and verified with visual analog gauges.
- Beaded thermocouples in combination with data loggers were used to record medium- and low-pressure steam temperatures.
- The integral type K thermocouple permanently installed to monitor furnace gas temperatures was connected to a 4-channel data logger to record temperature at the furnace exit.
- A portable KM 700 combustion efficiency analyzer was used to take periodic measurements of combustion efficiency and flue gas temperature at the exit of the HRSG. These readings were recorded manually. A type K thermocouple with a 4-channel data logger was used to digitally record flue gas temperature. The integral type K thermocouple permanently installed on the trailer was connected to an AFRL-owned Fluke thermometer module for control purposes.
- Three 100 A current transducers were used with a 4-channel data logger to record the electricity used by the TWES.
- Fuel consumption was monitored by measuring the fuel level within the 51-gal tank.

3.3.1. Summary of Observations and Activities During Testing

A variety of problems became apparent as the HRSG began to generate steam on the first day of testing (December 6), prior to the installation of non-integral sensors and data loggers. These problems included:

- The pressure gauge on the low-pressure steam line exiting the PRV was by-passed during the operation. It also appeared that the PRV was likely inoperable to extended storage. The ultrasonic flow meter that was to be used to monitor feedwater flow rate could not be used due to the lack of an accessible straight run of piping of the correct length.

Other observations included:

- Steam traps appeared to be operating as designed. The temperature profile across each trap was measured during operation with a non-contact infrared thermometer. All profiles were consistent with functioning traps.
- Permanently mounted instruments seemed to largely operate as designed, with the exception of the pressure transducers discussed above.
- Electric power distribution appeared correct. All major equipment and electrical components were found to receive the correct voltage.

After the testing on December 6, the non-integral sensors and data loggers were also installed per the data collection plan.

On the second day of start-up (December 7), the system was operated for approximately one hour. Before startup, the pressure gauge problems from the previous day were addressed. The existing pressure gauge from the water line exiting the feedwater pump was swapped with the post-PRV gauge. As the system only operated for one hour, steaming pressure was not reached. Testing was halted due to a fuel oil leak from the fuel supply pump, apparently from the pump seals. Before ending the test, the following problems became apparent:

- A small water leak was observed from the lowest blowdown pipe flange. It was unclear whether the flow came from water accumulating underneath the pipe insulation or a leak from the bottom of the boiler.
- A small water leak from the HRSG was observed. This was possibly from a bad weld between the back plate and a fire tube, or a leak from a tube itself. This problem warrants further investigation.

AFRL later reported that both leaks ceased upon the HRSG reaching steaming temperature, though their causes were not clear.

Due to delays caused by the pump seal replacement on the Beckett burner, the remainder of the testing was performed solely by AFRL after the end of ANTARES' visit on December 8. The loggers and associated equipment were shipped to ANTARES for data extraction and analysis. This data was collected during tests conducted on December 12, 13, and 15. There were several starts and stops on December 12 and 13, as shown in Table 1.

Table 1. Furnace Operational Hours During Test Period

Date	Start	Stop
12-Dec	7:23 a.m.	9:45 a.m.
	1:37 p.m.	3:30 p.m.
	3:50 p.m.	4:50 p.m.
13-Dec	9:23 a.m.	12:55 p.m.
	1:38 p.m.	1:59 p.m.
	2:32 p.m.	3:20 p.m.
15-Dec	7:39 a.m.	5:00 p.m.

4. RESULTS AND DISCUSSION

4.1. Temperature Readings

During the testing period, the main components of the steam system were able to operate stably. The system's temperature rate profiles for the duration of the three test periods that took place on December 12, 13, and 15 are presented in Figures 1-3, respectively. The test periods on December 12 and 15 lasted for approximately 9 hours each, while the testing period on December 13 was for only 6 hours. Several events are evident in the profile. First, the medium pressure steam (MPS) temperature and the HRSG flue gas temperature all mirror the top of the furnace insulation temperature, which is labeled as TE-240 on the graphs below. When the furnace temperature increases during the warm period, so do the remaining temperatures in the system. When the furnace is shut down at the end of the day, all of the system temperatures drop off. The HRSG flue gas temperature follows the furnace exit temperature the closest. Small dips in the furnace's temperature are shown in the HRSG temperature data. These small changes are much less pronounced in the MPS temperature readings.

While reviewing the data, it was determined that all of the low pressure steam (LPS) temperature recordings for all three testing days were incorrect. This is because the temperatures recorded were so low that it would be impossible for the water to be in a vapor state, unless the pressure in the steam piping was below atmospheric pressure. Similarly, the MPS temperature data for the third day was also very low. In order for the liquid in the MPS steam line to have been in a vapor state, the pressure would have needed to be lower than the atmospheric pressure. ANTARES believes that this may have resulted from bad connections in the thermocouple wiring. Since the data loggers were being disconnected at the end of each day for data download, and then reconnected for the subsequent day of testing, it is possible that connections in the wire nuts became loose, and the data recorded by the data logger was inaccurate.

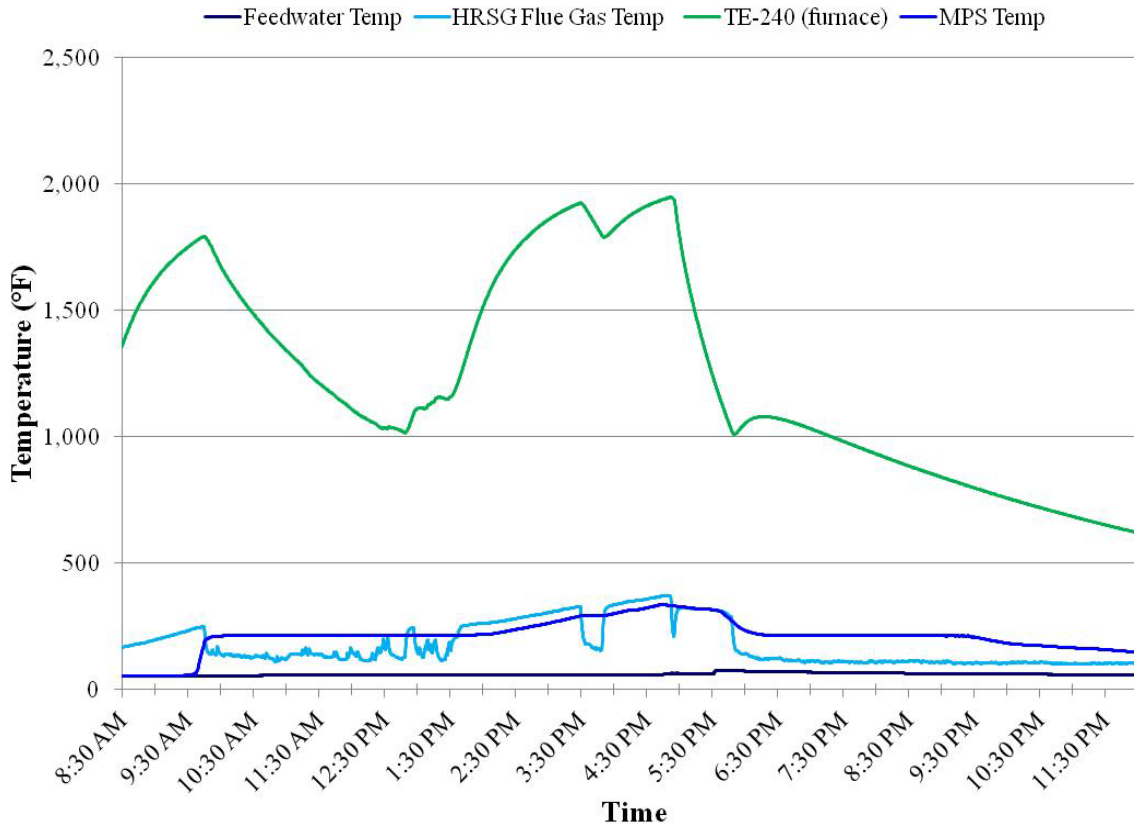

Figure 1. Temperature Profiles during Testing on December 12, 2011

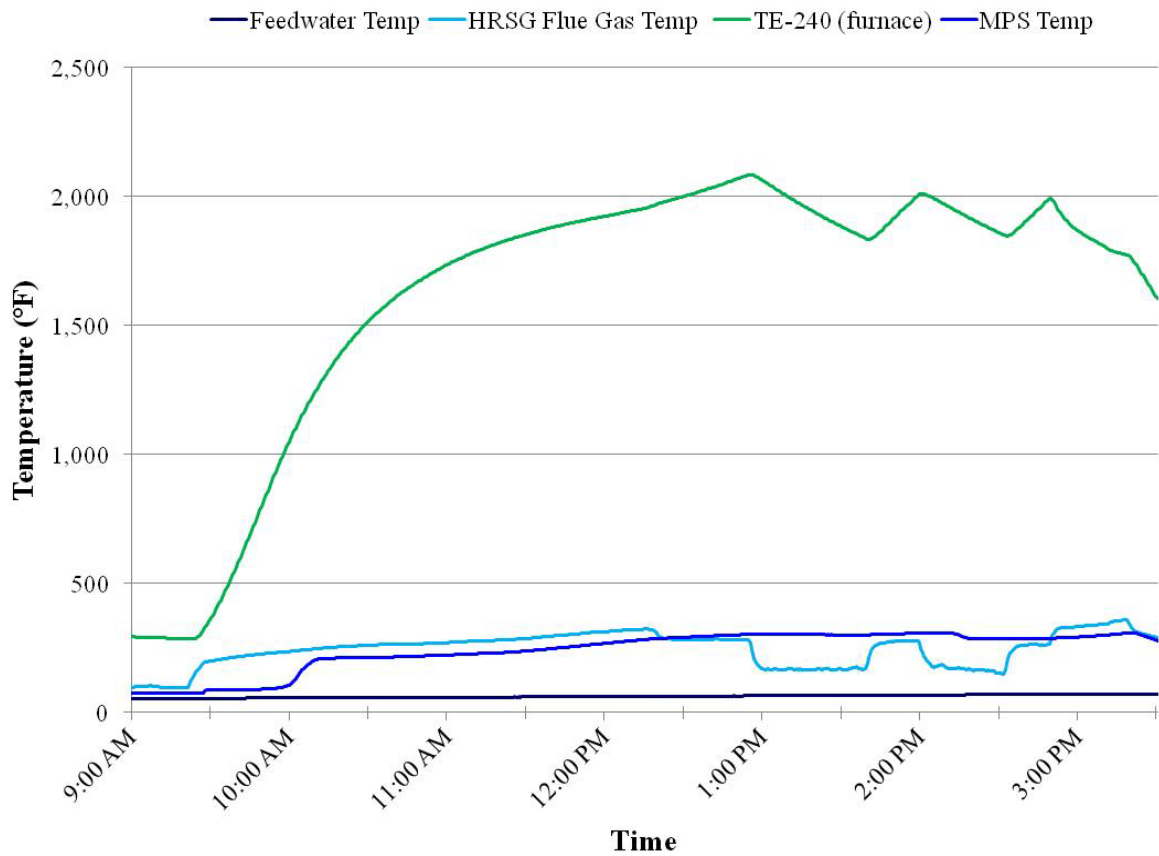

Figure 2. Temperature Profiles during Testing on December 13, 2011

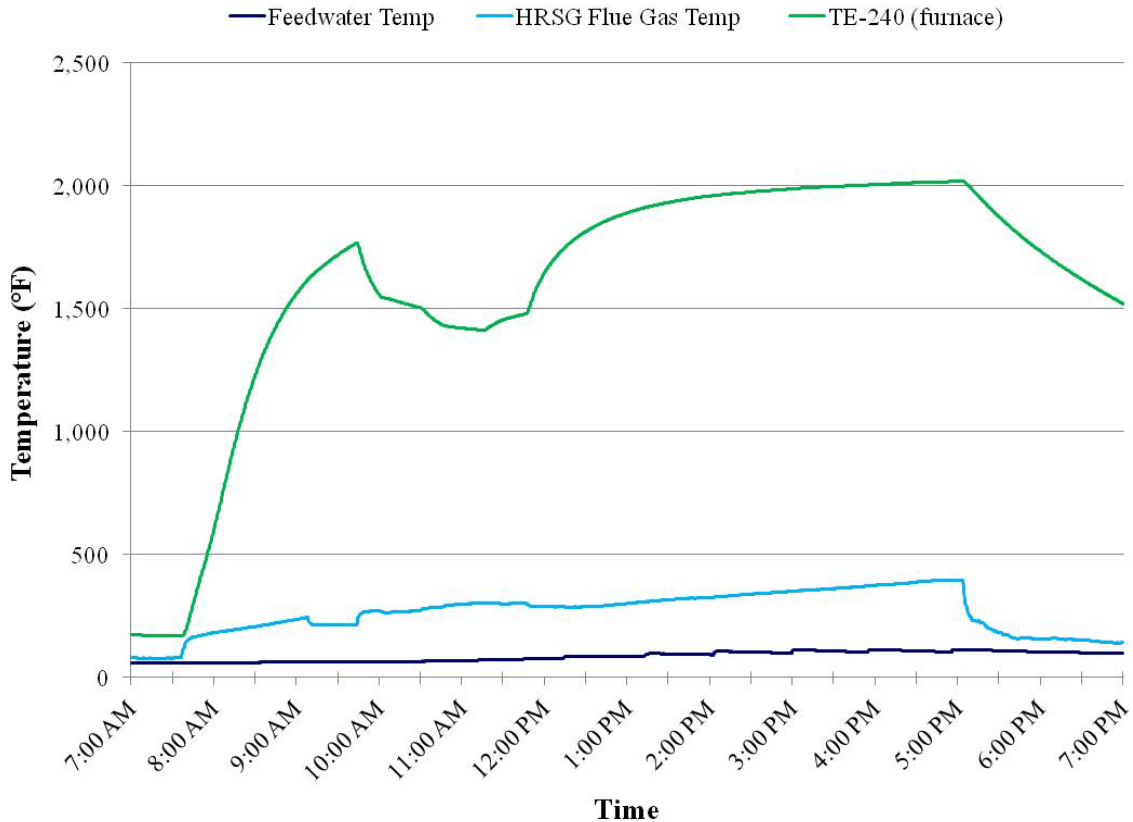

Figure 3. Temperature Profiles during Testing on December 15, 2011

4.2. Pressure Readings

In addition to the temperature readings, pressure readings were also recorded on both the LPS and MPS lines. The steam flow of the MPS line was also recorded. However, an evaluation of this data determined that it could not be used for further analysis because the values were clearly incorrect. Upon further investigation, it was determined that the pressure transducers were connected to the data logger incorrectly. The pressure transducer should have been connected in series with the data logger to a power source, which would be used as an excitation source for the transducers to produce a signal. Instead, the transducers were connected directly to the data loggers. As a result, the pressure and flow values that were recorded by the data loggers were drifting or floating values instead of accurate pressure readings.

Floating values can result from charges that are present around the data logger, and occur for a few different reasons. First, if the measurement device is not hooked up to a power source (but needs one to produce a usable signal), the data logger will not see any signal and can record a drifting, or floating value instead. The data logger will also record floating values if the connection cable into the data logger has been connected to the incorrect port, or a port that has not been pre-programmed to record the values. Finally, if the connection cable into the data logger is not plugged in all the way, the values recorded by the data logger may be distorted or floating values. The two separate data loggers that recorded the pressure values for the LPS and

MPS lines on the trailer, had very similar floating profiles over the course of the testing period. A technical representative from the data logger company (Onset Computer) indicated that this is very plausible because two data loggers in the same general environment would “see” the same charges, and as a result, would record similar floating profiles. Floating values seem have a general wave shape where they ramp up, and then ramp down over time. For reference, the pressure data can be seen in Appendix E. Power Usage

ANTARES also measured the three phase power signal to the trailer (Figure 4). It is expected that all three phases should have the same amplitude, but signal from the third phase was flat and consistently much lower than the other two throughout the entire three day test period. This could have been caused by one of two problems: a current transducer installed incorrectly or malfunctioning; or the third phase not receiving current. As the downstream equipment appeared to operate correctly, with no over-current problems at the breaker panel or motor sluggishness that would occur with a drastic phase imbalance, it was assumed that the current transducer was at fault.

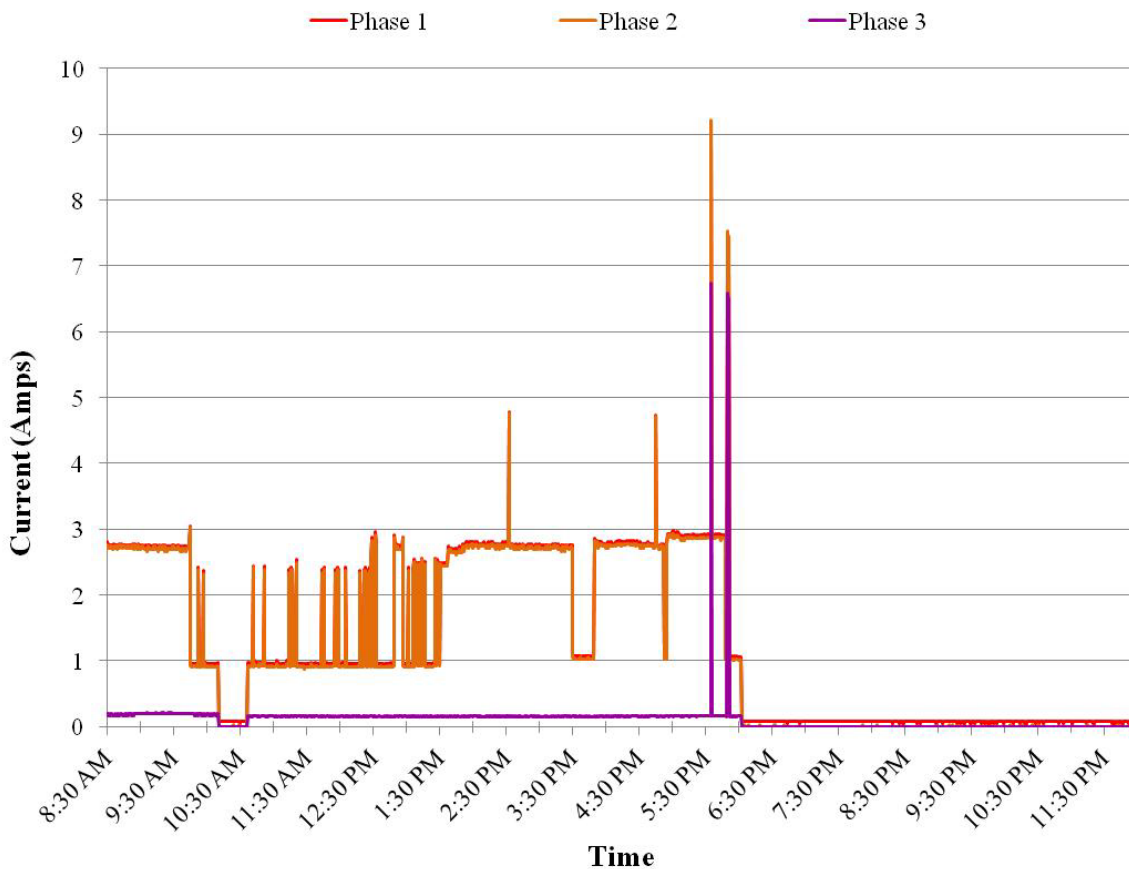

Figure 4. Three-Phase Power Signal to Trailer on December 12, 2011

The electrical demand of the TWES was calculated from the collected current measurements. In order to correct for the faulty transducer, the average current shown by the other two phases was assumed to equal the current for the third phase. This current and an assumed power factor of 0.8 (typical of small electric motors) were used to calculate instantaneous and peak electrical

demands (kW) and cumulative usage (kWh) throughout the submetering period. The demand profile is shown in Figure 5.

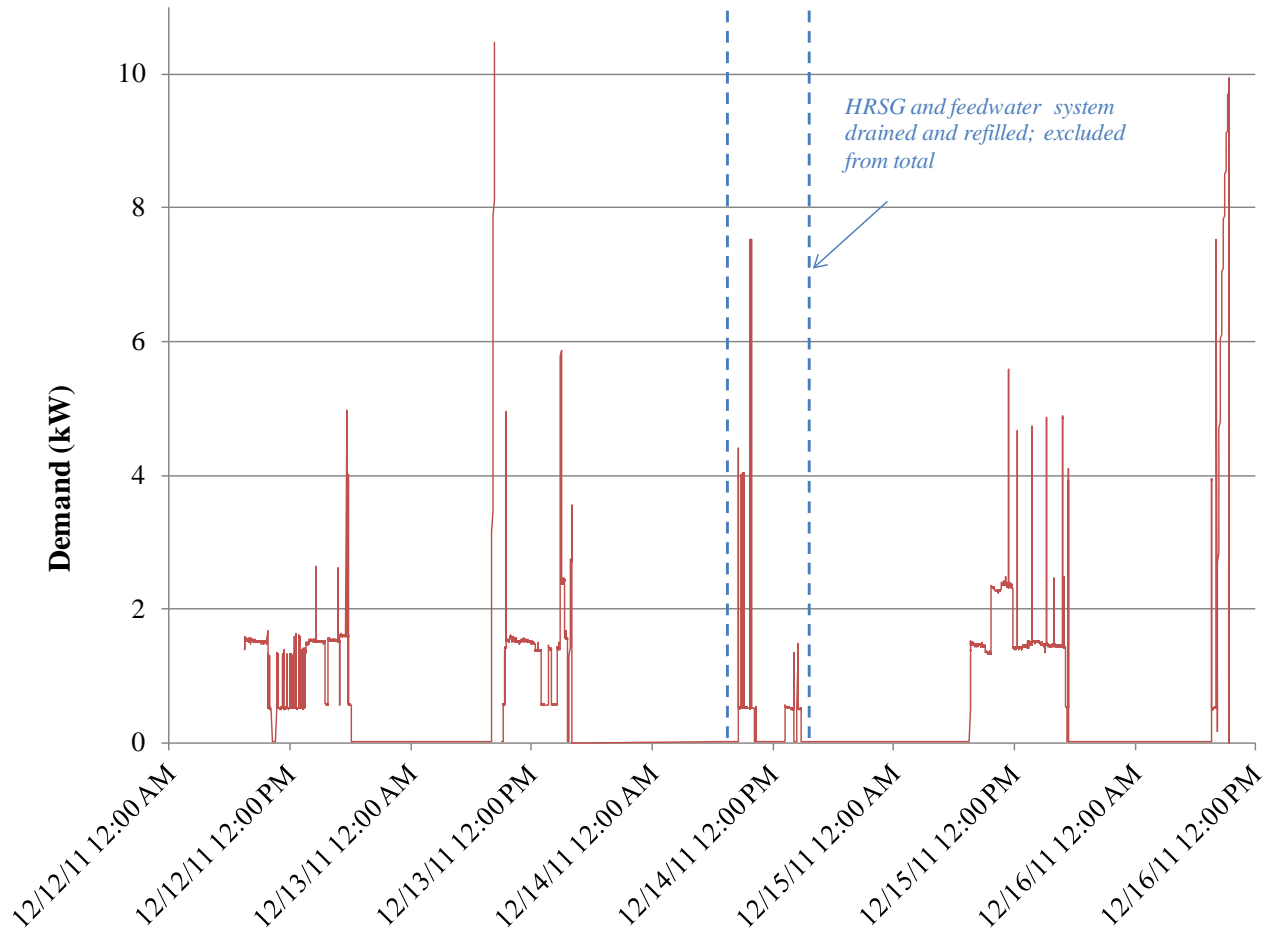

Figure 5. System Power Demand during Testing Period

Current measurements for the period on December 14, 2011, when the HRSG and feedwater system were completely drained and refilled, were excluded from the calculations as they are not normal activities required for generating steam. Exclusive of this period, from December 12 through December 15, 2011, the TWES used a total of 42 kWh, exhibiting a peak demand of 9.9 kW.

4.3. Steam Generation

Figure 6 shows the properties of steam generation during testing. These properties are limited because the only reliable temperature, pressure, and makeup water flow rate data points were the observed measurements recorded at periodic intervals by AFRL during the testing period from 7:39 a.m. to 5:00 p.m. on December 15, 2011. As discussed in 4.1 and 4.2, the temperature and pressure data recorded by the data loggers proved to be inaccurate. Hand-recorded steam pressure data was used in conjunction with saturated steam tables to generate the steam

temperature data shown in the graph. Since data was not necessarily recorded at the same time intervals during the whole testing period, ANTARES assumed that the temperature, pressure, and flow rate, stayed constant between recorded data points.

As stated earlier, ANTARES assumed that the HRSG started steaming around 10:26 a.m., which was the first recorded instance when the boiler water level dropped from the previous recording. During this warm up period, the system was still coming up to temperature and was not yet generating steam, and some of the heat from the combustion of diesel was absorbed into the system's resident water, refractory, and steel.

Although the system started steaming around 10:26 a.m., the system didn't develop pressure until 12:40 p.m.³ As can be seen in the graph, the steam pressure and temperature were steadily increasing from about 12:40 p.m. until the end of the detailed recorded period at 5:00 p.m.. The peak recorded steam temperature was 157 psig just before the unit was turned off on December 15. This pressure corresponds to a saturated steam temperature of about 370 °F. As a rough estimate based on the slope of the increasing steam temperature during the afternoon, ANTARES expects that the design medium pressure steam saturation temperature (406 °F, or 208 °C) and corresponding pressure of 250 psig would have likely been reached in another few hours of operation without any changes to the bypass valve.

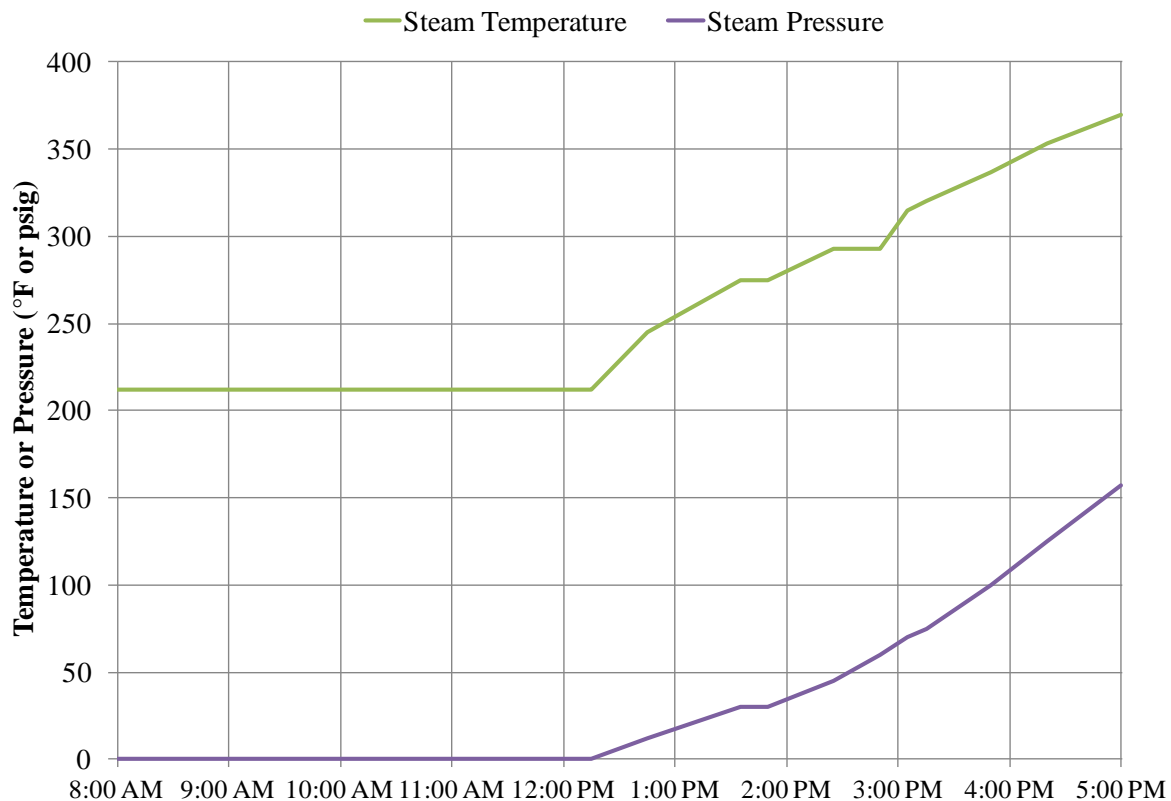

Figure 6. Steam Property Profiles during Testing

³ The length of time between first steam and pressure increasing may have been related to bypass valve settings.

Peak rates for makeup water and fuel consumption appear to have occurred in the mid-morning on December 15, 2011 during the period when an auxiliary blower supplied by AFRL was used to augment the burner in the Trailer 2 furnace. Discussion between AFRL and the burner manufacturer indicated that the increased fuel flow rate at this time was probably a function of the fuel pump's condition and the burner fire setting (high) rather than the air flow rate. The burner only modulates fuel flow based on firing rate settings of high or low with no other control inputs.

The combustion efficiency⁴ measured by the combustion analyzer during this peak consumption period was measured at 10:45 a.m. to be 81.4%⁵. Using the combustion and fuel to system efficiencies (the later shown in Table 3) and accounting for losses; the approximate fuel to steam efficiency is 76.9%. At this efficiency and fuel flow rate, with the feedwater and medium pressure steam conditions recorded at 10:45 a.m. and an expected parasitic steam load of 9% and 1% thermal losses, a net instantaneous steam flow rate of about 769 lb/hr could have been expected if the system were at steady state.⁶ However, the average steam flow rate for the December 15 testing period, 119 lb/hr (calculated based on water meter and sight glass readings at the beginning and end of testing) is far lower than the corresponding steady-state value. This discrepancy, partly due to energy required to warm the feedwater upon start-up and partly due to furnace-related heat losses, will be discussed in 4.5.1.

Data collection points for the water side of the system are identified in orange on the process and instrumentation diagram (P&ID) shown in Figure 7. Sample instantaneous state point data collected from both these points and several points on the gas side of the system at 5:00 p.m. on December 15, a point at which the system approached steady state operation, is presented as a heat and mass balance in Figure 9 and in tabular form in Table 2. This table also shows the projected values for: full load operation on diesel, if the system were to show the same efficiency using diesel as was predicted for biomass operation; future, full-load, open- and closed-loop operation on biomass. These projections are based on previous heat and mass balance modeling using Thermoflex commercial software from Thermoflow. The graphical output from this modeling, reported under a previous contract and applicable only to steady-state, full-load operation on biomass, is shown in Figure 8. The heat and mass balance for the instantaneous operation of the TWES at 5:00 p.m. on December 15 was estimated and is shown in Figure 9.

⁴ Please note that 81.4% combustion efficiency means that 81.4% of the fuel's heating value has been transferred to the system, for example to produce steam, blow-down or radiant losses.

⁵ For a detailed discussion on how the analyzer calculates excess air and combustion efficiency, please refer to Appendix D. This calculation does not account for the presence of unburned hydrocarbons; as will be discussed in the following pages, combustion may not have been complete, leading this measurement to be less accurate than anticipated.

⁶ Note that this instantaneous rate is representative of the system at only one point in time, not as an average over time. AFRL noted that at this point furnace temperature was steadily dropping due to the fact that the auxiliary blower pushes ambient air through the coils.

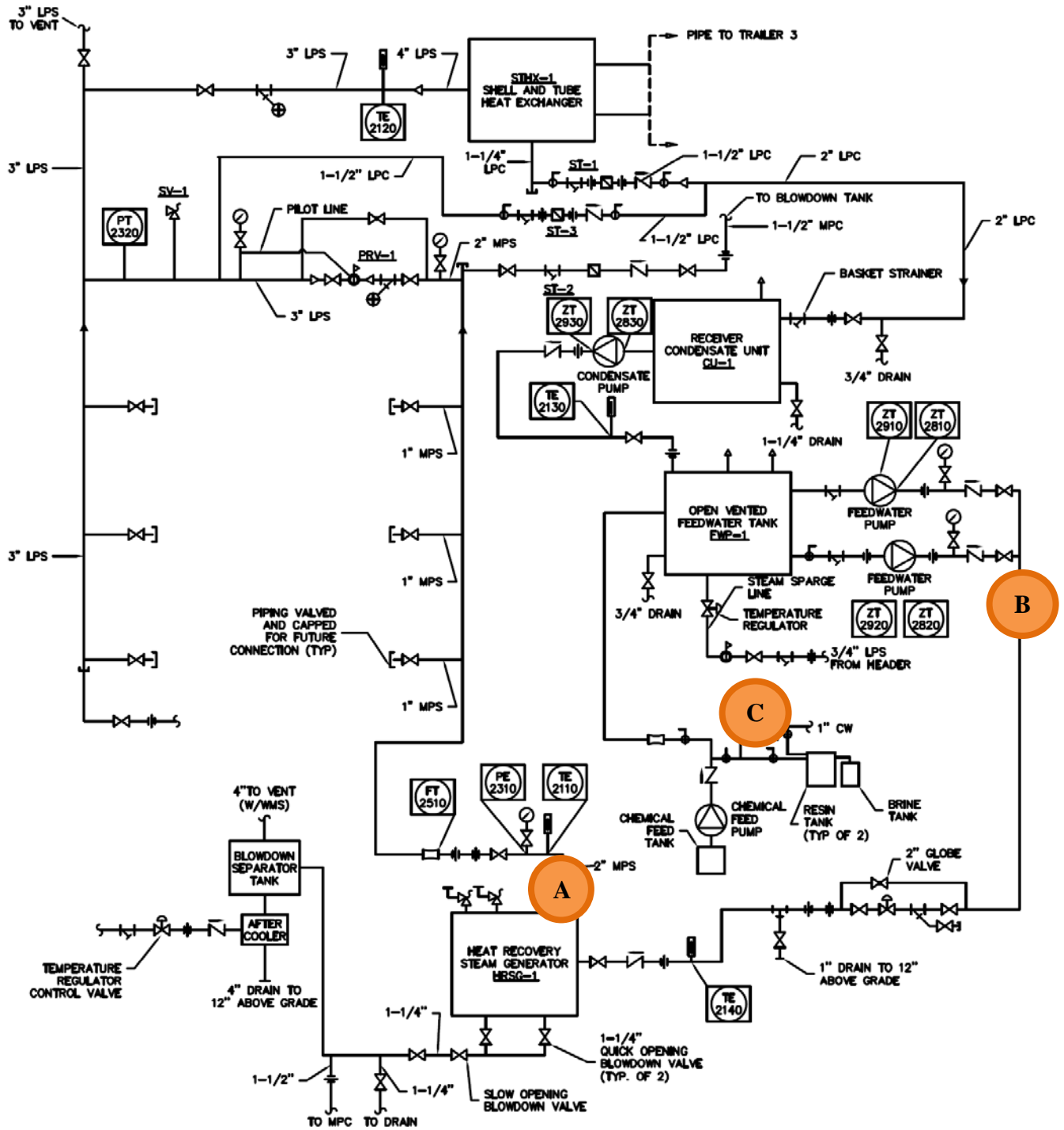
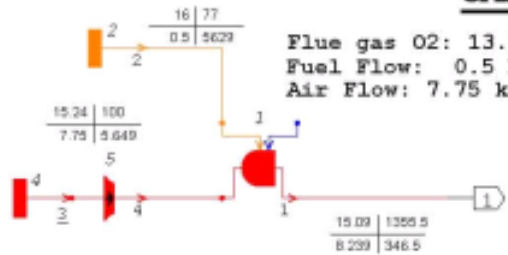

Figure 7. Key State Points

CASE: CHW and Power (40 Tons Summer Operation)



Flue gas O2: 13.36 %
Fuel Flow: 0.5 kpph
Air Flow: 7.75 kpph

Ambient temperature	92	F
Gross power	38.22	kW
Gross heat rate(LHV)	73643	BTU/kWh
Net power	10.56	kW
Net fuel input(LHV)	2814.3	kBTU/h
Net process output	467.9	kBTU/h
CHP efficiency	17.9	%
Net fuel input(HHV)	3167	kBTU/h

Label Key: (psia) | (F)
(kpph) | (Btu/lb)

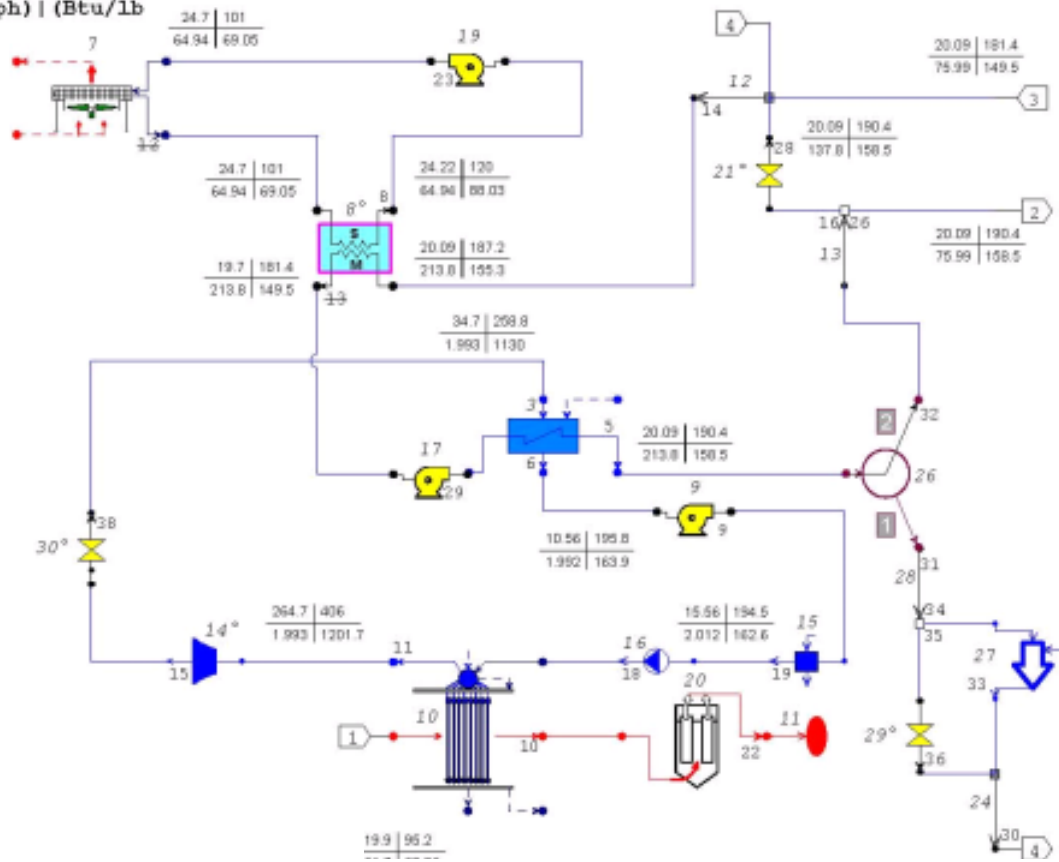

Figure 8. Graphical Heat and Mass Balance—Full Load Biomass Simulation

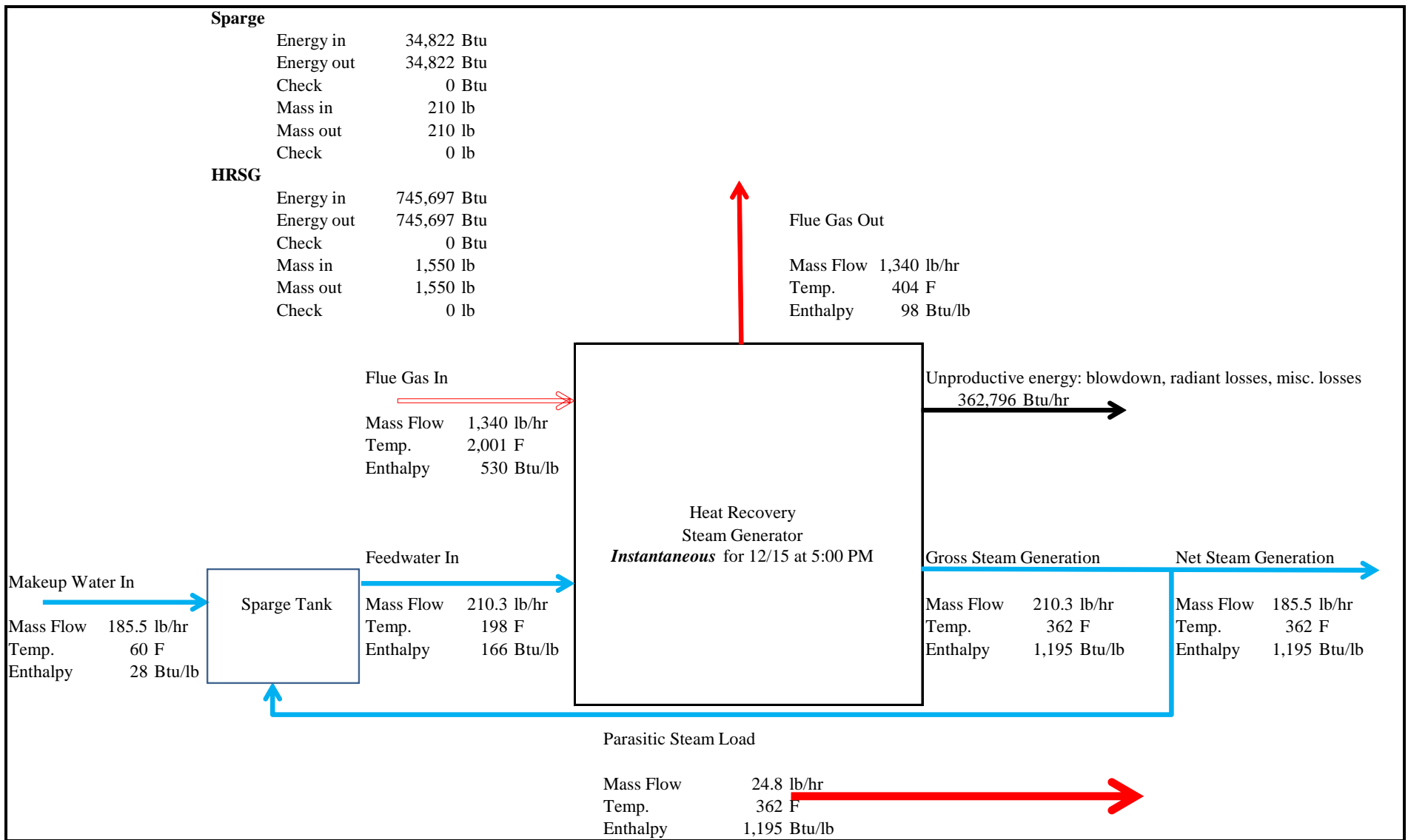

Figure 9. Spreadsheet-Based Heat and Mass Balance—Diesel Operation at 5:00 p.m., December 15

Table 2. Instantaneous Measured Conditions at Key State Points—December 15, 5:00 p.m.

	Key	A	B	C	Not Shown	Not Shown	Not Shown
	Stream	Steam Leaving TWES (net)	Feedwater Entering HRSG	Makeup Water Entering Feedwater Tank	Fuel Entering Furnace	Furnace Gas Entering HRSG	Flue Gas Leaving HRSG
Instantaneous Current Conditions (Diesel)	Pressure (psig)	157	-	-	-	-	-
	Temperature (°F)	369	252	60	60	2,001	404
	Flow Rate (lb/hr)	185.5	207.7	185.5	39.3	1,340	1,340
	Enthalpy (Btu/lb)	1,196	220	125.5	19,444	550	98.2
Expected Conditions (Diesel, full load)	Pressure (psig)	157	-	-	-	-	-
	Temperature (°F)	369	252	60	60	1,978	364
	Flow Rate (lb/hr)	1,233	1,381	1,233	100.8	1,490	1,490
	Enthalpy (Btu/lb)	1,196	220	0.0	19,444	375	68.4
Future Steady-State Conditions (Open Loop; Biomass)	Pressure (psig)	250	250	0	0	15	15
	Temperature (°F)	406	209	59	59	1,356	442
	Flow Rate (lb/hr)	1,815	2,035	1,815	500	8,239	8,239
	Enthalpy (Btu/lb)	1,202	176.9	27	6,230	n/a	n/a
Future Steady-State Conditions (Closed Loop; Biomass)	Pressure (psig)	250	0	0	0	15	15
	Temperature (°F)	406	209	59	59	1,356	442
	Flow Rate (lb/hr)	1,995	2,035	41	500	8,239	8,239
	Enthalpy (Btu/lb)	1,202	177	27	6,230	n/a	n/a

The furnace gas mass flow rates shown in Table 2 were calculated based on the gas temperatures measured at the top of the furnace and the average diesel fuel input rate of 6.4 gph. The gas flow rates for the first two cases in Table 2 were determined by using the charts in Appendix D⁷.

⁷ These gas flow rates were back checked using the diesel fuel input rate at 6.4 gph with a specific gravity of 0.88, a stoichiometric air to fuel ratio of 14.6, and excess air at 105% as measured by the combustion analyzer. The back check exercise resulted in a value of 1457 lb/hr, which is 2% less than the value reported in Table 2. The diesel fuel was also assumed to be fully combusted.

4.4. Analysis

Based on the steam pressure, water meter, and fuel tank data collected, ANTARES calculated the average fuel-to-steam efficiency for the system during the 9.3 hours of open-loop testing performed on December 15 (Table 3). Two cases are presented for review and are described below:

1. Measured conditions—this case assumes that all of the diesel fuel entering the furnace was combusted with stoichiometric air plus excess air. This case also uses the total water delivered to the boiler measured by the water meter (95 gal) and the estimated condensed steam introduced by the steam sparger (11 gal) over the 8.3 hour period. In this case on an HHV basis, the system averaged 22.1% net fuel-to-steam efficiency.⁸ On a gross fuel-to-steam basis (i.e., simple boiler efficiency) this value is approximately 25.1%.

ANTARES believes that this result is unlikely for a number of reasons explained below.

2. Probable conditions—this case assumes that the water meter readings are inaccurate; instead, 175 gal of total water were delivered to boiler based on the cycling of the feedwater pumps (to be discussed). Approximately 34.3% net fuel-to-steam efficiency (accounting for parasitics, radiant losses and blowdown) results. On a gross fuel-to-steam basis (i.e., simple boiler efficiency) this value is approximately 39.0%.

The net fuel-to-steam efficiency resulting from the probable conditions is significantly different than expected based on the measurements taken from the combustion efficiency analyzer, which indicated an average combustion efficiency of 84.5%, or net fuel to steam efficiency of 74.5%. It is also significantly different from the net fuel-to-steam efficiency, 65% (HHV), predicted by the Thermoflex modeling shown in Table 2 for the open-loop system operating on biomass.

A summary of key efficiency parameters is shown in Table 3. In this table, fuel-to-system efficiency refers to the total amount of heat productively used in the system, including the energy used to warm it to steaming temperature. The net fuel-to-steam efficiency counts only the energy used to produce steam from makeup water; warm-up energy is excluded.

⁸ For the tabulated values provided, ANTARES used the excess air measurements from the combustion analyzer and assumed that complete combustion occurred within the burner and furnace. The period when the auxiliary blower was used has been excluded from this average. For information on how the excess air measurements are provided by the analyzer, see Appendix D.

Table 3. System Efficiency Summary—December 15, 7:39 a.m. to 5:00 p.m.

	Case 1, Measured Conditions	Case 2, Probable Conditions
Diesel Flow Rate (gal)	51.0	51.0
Makeup Water (lb)	985	1,367
Makeup Water Enthalpy (Btu/lb)	34	34
Feedwater Entering HRSG (lb)	1,119	1,460
Feedwater Enthalpy (Btu/lb)	107	107
Steam Leaving HRSG (lb)	1,218	1,893
Steam Enthalpy (Btu/lb)	1,174	1,174
Net Energy Output (Btu)	1,577,865	2,451,782
Energy to Heat Refractory (Btu)	430,562	430,562
Energy to Heat HRSG (Btu)	874,310	874,310
Fuel Heat Input (HHV; Btu)	7,140,000	7,140,000
HRSG Efficiency	85.0%	85.0%
Fuel-to-System Efficiency (HHV)	40.4%	52.6%
Net Fuel-to-Steam Efficiency (HHV)	22.1%	34.3%

4.4.1. Variance of Results

A number of factors may be responsible for the difference between these two cases and the expected efficiency range of about 70–80%, including the following:

- *Energy required to heat the system from ambient temperature to steaming temperature.* The HRSG has a large thermal mass in the form of 647 gal of water at normal level. This would require 874,300 Btu of fuel energy to reach atmospheric steaming temperature, 212 °F, from the 60 °F starting condition. Similarly, the refractory and insulation for the HRSG and furnace could require as much as 430,600 Btu to reach operating temperatures.⁹ Even without considering the energy required to heat the metal surfaces of the system, the HRSG water and refractory sensible heat loads account for approximately 9.3 gal, or over 20%, of the fuel combusted on December 15. Though the net fuel-to-steam efficiency calculation counts this energy as though it were evaporating steam, it is being consumed only to bring the system to temperature, not for steam generation. The effect of this heat sink can be isolated by examining the 167-min period ending at 10:26 a.m., when the system reached steaming temperature. The expected heat sink together with the actual fuel consumption for this time, 14 gal, leads to an average dynamic fuel-to-system efficiency of 67%. While lower than the expected value for steady-state operation, it is appropriate for dynamic operation far from design conditions.

⁹ This calculation assumes: 1,306 lb of heavy refractory in the furnace reaching a mass-averaged temperature of 766 °F at 0.25 Btu/lb- °F; 914 lb of mineral fiber insulation in the duct reaching a mass-averaged temperature of 766 °F at 0.27 Btu/lb- °F; and 236 lb of mineral fiber insulation in the furnace reaching a mass-averaged temperature of 469 °F at 0.27 Btu/lb- °F. These estimates are based on equipment dimensions and specifications, but should not be treated as exact.

- *Inaccurate water metering.* The water meter was not calibrated before the test period and spent a long period of time in storage, unused. Even though the water meter readings for the full drain and refill of the feedwater system compare well to the expected volume of the feedwater system, the feedwater pumps did cycle on five times during the analysis period on December 15 as evidenced by the electrical submetering data. ANTARES believes that this should correspond to about 35 gal of feedwater per fill (175 gal total), equivalent to about 32.8 gal of makeup water per fill (163 gal total).¹⁰ This expected makeup water total is much greater than the 95 gal recorded by the water meter. That said, this and all meters on the TWES should be calibrated and tested to confirm their accuracy.
- *Radiant and potentially convective heat losses through the upper furnace coils.* It is evident that upon entering the HRSG, heat was being effectively transferred to the water: there was a consistently large differential between entering and exiting flue gas temperatures. By the end of the day these had reached approximately design conditions. For example, at 5:00 p.m., the temperature differential of 1,356 °F indicated that of 78% of the flue gas energy entering the HRSG was removed from that stream by the time it exited. Accordingly, it is reasonable to expect that the most significant deviations from expected efficiency occurred not in the HRSG, but rather in the furnace. One potential loss of heat in the furnace is the upper combustion coil.



Figure 10. Uninsulated Combustion Coil Inlet

As shown in Figure 10, the protruding outlet of the upper combustion coil was not insulated for testing, providing effectively a long cooling fin for the hot gases from the center of the combustor to shed heat via conduction to the ambient air. The outlet of the combustion coil was

¹⁰ A steam to makeup water ratio of about 6.84% was determined by solving the two-variable system of equations provided by the known feedwater mass and enthalpy and the known steam and makeup water enthalpies. The 175 gal total is the sum of both condensed steam sent to the sparge tank and makeup water sent through the water meter.

closed with a butterfly valve after use of the auxiliary blower during testing on December 15, preventing convective heat transfer, but conduction losses alone may be significant since this section of pipe reached 800 °F during testing, providing an excellent temperature differential for radiant loss. This could help explain some of the heat balance disparities, but without more data, this is difficult to quantify.

- *Diesel fuel entering burner was not combusted.* While no smoking or other stack opacity was reported during the test, there is the potential for incomplete combustion with a combustion fan that was potentially undersized for the gas-side pressure drop. Based on discussion with Beckett, the burner manufacturer, an incorrect spray angle for the chamber may also be present. While it is impossible with the data available to quantify the amount of fuel left un- or only partially combusted, the potential for such a loss is significant.
- *A higher than expected steam parasitic load at the sparge tank* due to open loop operation and a 100% makeup water rate based upon the net steam generated by the HRSG. The sparge tank was designed for 50% makeup water, not 100%, requiring more steam than expected to preheat the feedwater to the HRSG. The efficiency should improve significantly with closed loop operation.

Another key piece of evidence supporting a problem with the water metering (as assumed by Case 2) is the electrical demand profile of the TWES during the December 15 testing period. Operation of the 5 hp feedwater pump, loaded at a typical 80% would register in the profile as an approximately 3.0 kW spike. Five such spikes are apparent during the analysis period in the demand profile shown in Figure 11. Each time the feedwater pump operates, it is expected to transfer approximately 35 gal of feedwater to the HRSG, leading to a total expected feedwater flow of 175 gal (1,460 lb) for the December 15 analysis period. This value does not agree well with the measured conditions, putting the water meter's accuracy into question.

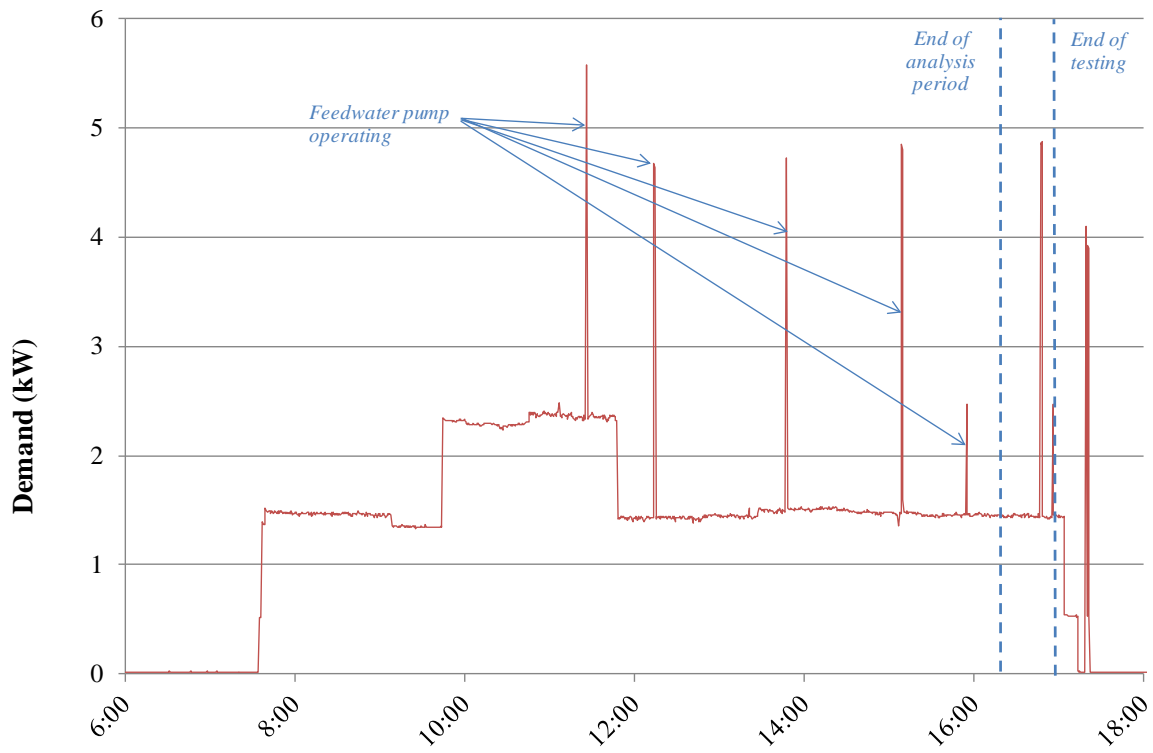

Figure 11. Demand Profile—December 15

5. CONCLUSIONS

Phase I of the Transportable Waste to Energy project was completed by ANTARES, its subcontractors, and AFRL. Trailer #2 was tested and commissioned at Tyndall AFB in December of 2011. It operated stably over time and was partially integrated with the previously constructed Trailer #1. When firing diesel fuel in an open-loop configuration, it achieved a 53% (probable case) average fuel-to-system efficiency (HHV basis) while firing diesel fuel. All equipment with the exception of the PRV and instrumentation with 4-20 mA outputs appeared to operate as designed, though the system was not run for long enough to reach steady-state conditions.

As stated in the Test Plan (Appendix F), the goal of the testing was to confirm that “the TWES furnace and steam generator are able to produce any steam as identified visually via the steam vents (threshold 1), 240 lb/hr at 250 psig at 205 °C (threshold 2) and 480 lb/hr (objective),” (Bowen, 2011 p. 3). A further operation goal was to have an overall conversion efficiency of at least 50%.

Based on the analysis of the test results, threshold 1 was met. Although the system never reached a pressure of 250 psig as identified in threshold 2, the steam pressure was steadily increasing during operation on the afternoon of December 15' up to a recorded pressure of 157 psig. Although threshold 2 was not met during testing, there is reason to believe that this target could be achieved if the system was operated long enough to reach steady state. The 480 lb/hr objective was not met either; however, ANTARES believes that this was due to furnace-related problems detailed earlier and that the biomass system would have been able to achieve this steaming rate. Data supports that despite a net fuel-to-steam HHV conversion efficiency of only 34.3%, which did not meet the objective value of 50%, the TWES showed an average HRSG efficiency of 85%.

These results mark genuine progress towards a final, operational system. However, at this time this system is not yet able to harness the benefits of the steam produced. Follow-on phases to build trailer three and run the combustion chamber with biomass are required to have a system capable of self sustainment and energy production.

6. RECOMMENDATIONS

The following near term actions are recommended:

- Complete the construction on Trailer 2, which should be limited to integrating the controls on Trailer 2 with those on Trailer 1, calibrating data acquisition devices, and repairing the PRV.
- Perform functional test on both Trailers 1 and 2 using biomass, which can serve as a basis for commissioning the controls and data acquisition system.
- Obtain a high temperature anemometer (range up to 500 °C) to insert in flue gas stack of the HRSG. Analyze data collected during functional tests and confirm that the HRSG operates with an 80+% efficiency.

In addition, the following longer term actions are also recommended to optimize the safety, reliability, and performance of the TWES system:

- Procure and install steam piston engine(s) for Trailer 2. These engines can generate up to 45 kW and offset some of the electric demand for the equipment on Trailer 1 and 2.
- Integrate the hot water loop and construct Trailer 3, which will provide a closed loop operation for the TWES. This would increase the Trailer 2 steam generation plant efficiency by an estimated 2–4% (depending on operating steam pressure) by substantially reducing the parasitic load to preheat makeup water.
- Design and construct the chilled water loop, which will reside on Trailer 4. Based on preliminary heat and mass balance modeling, this could generate over 100 tons of refrigeration in the form of chilled water.
- Re-design furnace to automatically remove ash generated during biomass combustion
- Perform functional testing of four trailer configuration with mixed waste fuel sources
- Deploy TWES trailers to a relevant application

7. REFERENCES

- 1) **Antares Group, Inc. 2008.** *Transportable Waste to Energy System (TWES) for Sustainable Electricity Generation—Basic Design Package and Furnace Testing*. Technical Assistance Task Order DE-AT36-G027498. U.S. DOE, 2008.
- 2) **Bowen, Lt. Thomas. 2011.** *Transportable Waste-to-Energy System (TWES) Operating the Steam Generator with Diesel Burner, Test Plan*. Tyndall AFB : AFRL, 2011.
- 3) **Kane.** *How is Combustion Efficiency Calculated*. Accessed from <http://www.kane.co.uk/tech-tips-faqs/324-how-is-combustion-efficiency-calculated> on 23 March 2012.
- 4) **Lindsey, Chris and Sawyer, Mikel. 2009.** “Emissions Performance of a Novel Combustor Burning Shredded Wood,” NAWTEC17-2344, *Proceedings of 17th Annual North American Waste-to-Energy Conference*, Chantilly, Virginia, USA: ASME, May 18-20, 2009.

Appendix A: AutoCAD Drawings

Selected AutoCAD drawings are shown below.

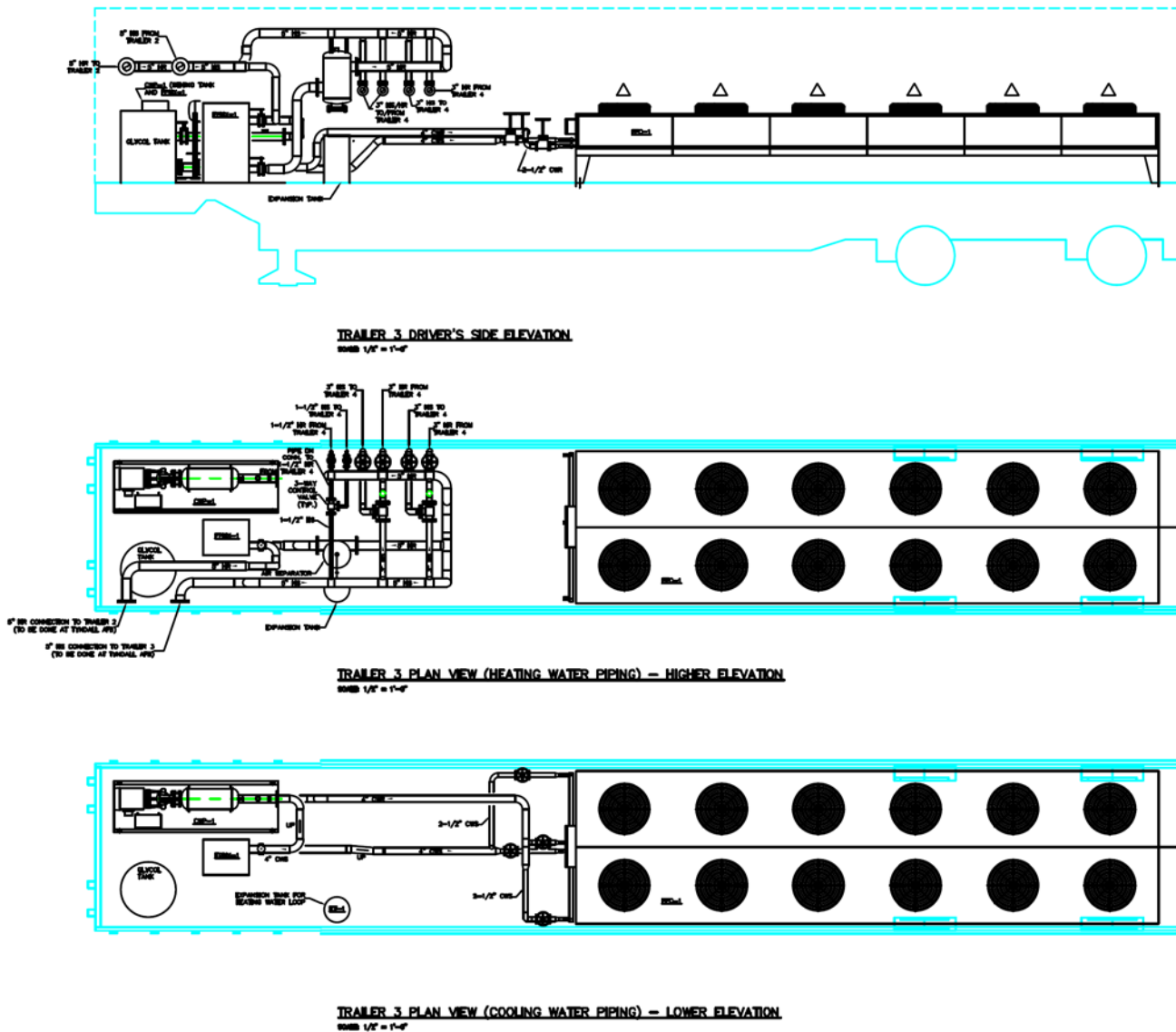

Figure A-2. TWES Trailer 3 Mechanical Plans and Elevations—Phase 1 (Drawing M-3 from 7/27/2009)

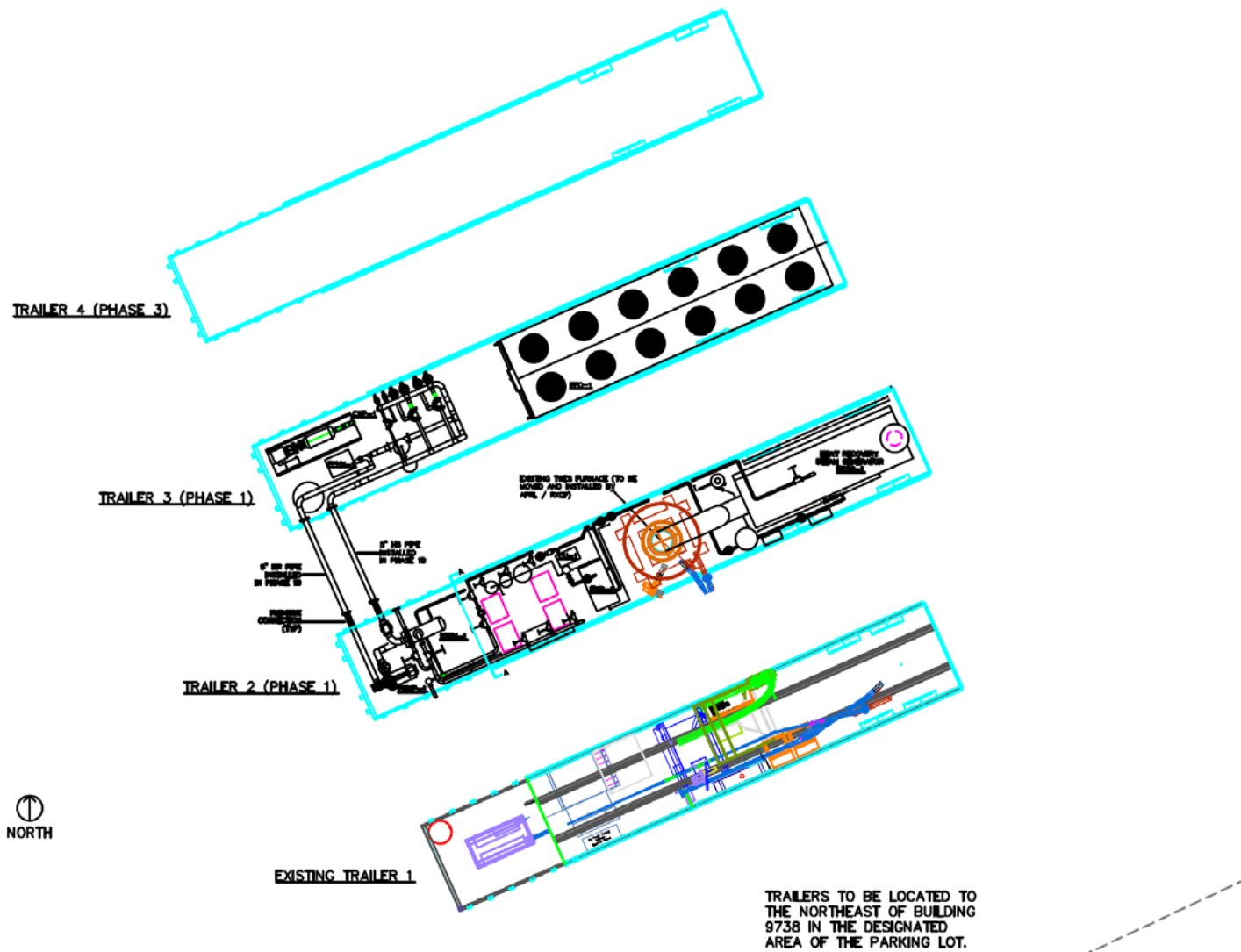

Figure A-3. TWES Trailer Site Plan—Phase 1 (Drawing M-4 from 7/27/2009)

Appendix B: Annotated Punch List

The annotated punch list below is based on the list submitted to AFRL on April 25, 2011. The right-most column includes ANTARES observations of completion during testing in December 2011. The punch list is divided into five areas that need to be completed for this project, which include construction, system commissioning, training, testing / startup, and final delivery. The items for each area are listed below in the bulleted list. Items in *italics* are not critical and may be omitted for budgetary or time constraints.

Punch List Item Description	Complete
<u>Construction</u>	
<ul style="list-style-type: none"> • Combustor and accessories (diesel tank, diesel burner, pressure transducer panel, thermocouples, etc.) to move from Trailer 1 to Trailer 2. 	Completed
<ul style="list-style-type: none"> • Flex I/O panels must be mounted on the first and second trailer. The existing panel on Trailer 1 will move over to Trailer 2, and the new panel will be re-wired mounted on Trailer 1. 	Note 1
<ul style="list-style-type: none"> • Connect via Ethernet cable the control panels on Trailer 2 to those on Trailer 1 	Not completed
<ul style="list-style-type: none"> • <i>Paint flue gas duct Air Force Blue to match existing ductwork</i> 	<i>Not required</i>
<ul style="list-style-type: none"> • Connect flue gas duct from combustor to boiler 	Completed
<ul style="list-style-type: none"> • Silicone caulk should be applied to joints on boiler and feedwater tank. 	Note 2
<ul style="list-style-type: none"> • The power supply to the furnace control panel to be connected properly. 	Completed
<ul style="list-style-type: none"> • Procure / set-aside any electrical items that are needed, such as the pin-sleeve connector, extension cord, step-down transformer, etc. 	Completed
<ul style="list-style-type: none"> • Perform modifications to Trailer 1 so Trailer 2 can be electrically connected to Trailer 1 (install disconnect, pin-sleeve connector, make new cable to power Trailer 2 from Trailer 1, etc.) 	Completed
<ul style="list-style-type: none"> • Final programming to the Allen Bradley PLC and RS View 	Not completed
<ul style="list-style-type: none"> • <i>Each yellow flow direction indicator label on the piping should be accompanied by a fluid identifier label (e.g., "Med. Pressure Condensate") for easier identification.</i> 	<i>Not required</i>
<ul style="list-style-type: none"> • Connect drain pipes to the condensate return tank, relief valves and the blowdown tank. 	Completed
<ul style="list-style-type: none"> • Steam flow meter should be installed in the medium pressure steam line (remove spool piece and re-insert in steam line). 	Note 3
<ul style="list-style-type: none"> • Fill water tank truck and provide pump or attach trailer to water line at the building. 	Completed
<ul style="list-style-type: none"> • Connect water line to tank truck / building and provide the proper fittings to make the water connection. 	Completed
<ul style="list-style-type: none"> • Fill boiler and treat water per manufacturer's recommendation 	Completed
<ul style="list-style-type: none"> • Modify fuel delivery piping for new combustor location 	Not completed
<ul style="list-style-type: none"> • Connect / hardwire emergency stops to Trailer 1 	Not completed

<ul style="list-style-type: none"> Connect Trailer 1 to building power 	Completed
<u>System Commissioning</u>	
<ul style="list-style-type: none"> Confirm operation of existing Trailer 1 after modifications and storage period 	Completed
<ul style="list-style-type: none"> Perform functional testing of the equipment (boiler feedwater pumps, chemical feed pump, condensate tank pump, etc.) and the control sequences 	Completed
<ul style="list-style-type: none"> Confirm pipes are holding water and no leaks are evident after delivery 	Completed
<ul style="list-style-type: none"> Adjust low pressure steam on PRV station 	Note 4
<ul style="list-style-type: none"> Verify steam traps are operating properly 	Note 5
<ul style="list-style-type: none"> Verify operation of thermocouples and pressure transducers added on Trailer 2, not including combustor 	Note 6
<ul style="list-style-type: none"> Verify operation of emergency stops 	Not completed
<ul style="list-style-type: none"> Test convenience outlets and electric power distribution 	Completed
<u>Training</u>	
<ul style="list-style-type: none"> Review operator safety items 	Completed
<ul style="list-style-type: none"> Review operator manual and key items to watch during normal operation 	Completed
<u>Testing and startup</u>	
<ul style="list-style-type: none"> Procure fuel for testing and startup 	Completed
<ul style="list-style-type: none"> Ensure adequate water supply is available for each day of testing 	Completed
<ul style="list-style-type: none"> Log performance data on fuel flow, steam production, makeup water flow, steam pressure and temperature on medium and low side of PRV, stack temperatures 	Completed
<ul style="list-style-type: none"> Log power consumption for both Trailer 1 and Trailer 2 use clamp-on current transducers 	Completed
<ul style="list-style-type: none"> <i>Obtain fuel samples for laboratory analysis</i> 	<i>Not required</i>
<ul style="list-style-type: none"> <i>Ash analysis and daily cleanup for quantity of bottom ash</i> 	<i>Not required</i>
<ul style="list-style-type: none"> <i>Emissions testing</i> 	<i>Not required</i>
<u>Final Delivery Items / Documentation / Reporting</u>	
<ul style="list-style-type: none"> Operator manual (including equipment manuals) 	Completed
<ul style="list-style-type: none"> SolidWorks drawing of Trailer 2 (as-built) 	Completed
<ul style="list-style-type: none"> Final report of results of commissioning effort, testing and startup 	Draft Complete
<ul style="list-style-type: none"> Transfer ownership of trailer 	Completed
<ul style="list-style-type: none"> Drain system 	Completed
<ul style="list-style-type: none"> Disconnect power 	Completed
<ul style="list-style-type: none"> Boiler layup 	Completed

<u>TWES Trailer 2 Inspection</u>	
<ul style="list-style-type: none"> Hydrostatic test of steam, steam condensate and water lines. The piping held pressure in Syracuse before delivery, but it should be verified. 	Completed
<ul style="list-style-type: none"> Check that all hand valves can be operated and haven't rusted shut or open 	Completed
<ul style="list-style-type: none"> Inspect the boilers internals (i.e. check tube cleanliness) 	Completed
<ul style="list-style-type: none"> Check pressure gauges and thermometers for physical damage. 	Note 7
<ul style="list-style-type: none"> Check insulation and aluminum jacketing for physical damage. 	Completed
<ul style="list-style-type: none"> Check the boiler exterior for damage and make sure the door of the boiler opens at the rear of the trailer 	Note 8
<ul style="list-style-type: none"> Check the other steam equipment and accessories for damage including <ul style="list-style-type: none"> Blowdown tank Feedwater tank and pumps Shell and tube heat exchanger 	Completed
<ul style="list-style-type: none"> Check the makeup water system and piping for damage including <ul style="list-style-type: none"> Chemical feed tank (under the feedwater tank) Water softener and brine tank 	Completed
<ul style="list-style-type: none"> Check AB Flex I/O control panels for damage 	Note 9
<ul style="list-style-type: none"> Check electric receptacles and panels for damage 	Note 1
<ul style="list-style-type: none"> Inspect exhaust duct and expansion joint for damages 	Completed
<ul style="list-style-type: none"> Inspect steam flowmeter for damages (to be inserted where spool piece resides on 2" MPS header) 	Completed
<ul style="list-style-type: none"> Inspect welds on pipe supports and boiler 	Completed
<u>TWES Combustor 2 Inspection Suggestions</u>	
<ul style="list-style-type: none"> Inspect coil supports for deformation, specifically for areas of potential failure 	Completed
<ul style="list-style-type: none"> Inspect insulation, especially in areas near the bottom of the combustor 	Completed
<ul style="list-style-type: none"> Inspect for debris on bottom of the combustor. The original designers of the combustor did not provide an ash removal system. As such debris must be physically removed after each test. Potential debris could include left over clinkers and pieces of insulation. 	Completed
<ul style="list-style-type: none"> Verify positioning of blast shield 	Completed
<ul style="list-style-type: none"> Inspect thermocouples 	Completed
<ul style="list-style-type: none"> Test blowers 	Completed
<ul style="list-style-type: none"> Inspect and test preheat burner 	Completed

Notes:

1. One of the three Flex I/O panels was not seen on the trailers during the testing. It was assumed that this panel was placed in storage until the controls could be connected.
2. Silicone caulk may not have been applied to all of the openings on the HRSG based on the state of the trailer upon shipment. ANTARES recommends verifying that all seams have been properly caulked.
3. The steam flow meter was inserted; however, the remote display wasn't installed or delivered. The flow meter didn't appear to work during the test; therefore ANTARES recommends that it be sent out for calibration before the next testing occurs. The 4-20 mA cable was not connected properly to the data logger, so ANTARES cannot confirm if the problem is with the display or the flow meter. The pressure transducer should have been connected in series with the data logger to a power source, which would be used as an excitation source for the transducers to produce a signal. Instead, the transducers were connected directly to the data loggers. As a result, the pressure and flow values that were recorded by the data loggers were drifting or floating values instead of accurate pressure readings.
4. AFRL reported that the PRV did not function properly during testing. The bypass valve was used to manually maintain downstream pressure.
5. The steam traps were not tested for proper operation as the steam system was open to the atmosphere. AFRL reported no condensate plugs exiting the steam vent, no evidence of steam entering the condensate system, and no inability of the HRSG to near operating pressure. These would be symptoms of trap failure. In the absence of these symptoms, it was assumed that the traps were operational.
6. Pressure transducers were not connected properly to the data loggers so ANTARES cannot confirm their operation. Thermocouples appear to be operable, although they were not labeled. ANTARES believes that inaccurate data may have resulted from bad connections in the thermocouple wiring. Since the data loggers were being disconnected at the end of each day for data download, and then reconnected for the subsequent day of testing, it is possible that connections in the wire nuts became loose, and the data recorded by the data logger was inaccurate.
7. Pressure gauges on both the LPS line exiting PRV and at top of HRSG were not operable, though these were replaced for testing purposes with gauges taken from the feedwater system. The gauge at the top of the HRSG was not installed before testing; upon installation, this gauge, too, was found to be inoperable.
8. No damage was evident. However, there was a small leak from the back of the HRSG. ANTARES was not able to open the rear of the HRSG during the testing.
9. Cover was missing to the softener tank.

Appendix C: Index of Submittals

Submittal Number	Section Name	Product Type
TWES-01320-01	CONSTRUCTION PROGRESS DOCUMENTATION	
TWES-01320-02		
TWES-15061-01	HANGERS AND SUPPORTS FOR PLUMBING PIPING AND EQUIPMENT	Metal pipe hangers and supports.
TWES-15061-02 (see TWES-15061-01)		Thermal-hanger shield inserts.
TWES-15061-03 (see TWES-15061-01)		Equipment supports.
TWES-15061-04 (see TWES-15061-01)		Equipment supports.
TWES-15061-05		Welding certificates
TWES-15062-01 (see TWES-15061-01)		HANGERS AND SUPPORTS FOR HVAC PIPING AND EQUIPMENT
TWES-15062-02 (see TWES-15061-01)	Thermal-hanger shield inserts.	
TWES-15062-03 (see TWES-15061-01)	Equipment supports.	
TWES-15062-04 (see TWES-15061-01)	Equipment supports.	
TWES-15062-05 (see TWES-15061-05)	Welding certificates	
TWES-15074-03 (see TWES-15061-01)	VIBRATION CONTROLS FOR HVAC PIPING AND EQUIPMENT	
TWES-15074-05 (see TWES-15061-01, TWES-15061-05)		Metal pipe hangers and supports, Welding certificates
TWES-15076-01	IDENTIFICATION FOR PLUMBING PIPING AND EQUIPMENT	Warning signs and labels
TWES-15076-02		Pipe labels
TWES-15076-03		Pipe labels
TWES-15076-03 (2)		Pipe labels
TWES-15076-04		Pipe labels
TWES-15076-05		Paint
TWES-15077-01 (see TWES 15076-1)	IDENTIFICATION FOR HVAC PIPING AND EQUIPMENT	Equipment labels
TWES-15077-02		Warning signs and labels
TWES-15085-01	PLUMBING PIPING INSULATION	Drain piping exposed to freezing conditions
TWES-15085-01a		Drain piping exposed to freezing conditions
TWES-15085-03 (see TWES 15061-01)		Detail application of protective shields, saddles, and inserts at hangers for each type of insulation and hanger.
TWES-15087-01	HVAC EQUIPMENT INSULATION	Heat exchangers
TWES-15087-02 (see TWES 15085-01a)		Detail application of protective shields, saddles, and inserts at hangers for each type of insulation and hanger.
TWES-15088-012	HVAC PIPING INSULATION	Steam and steam condensate piping outdoors.
TWES-15088-02 (see TWES 15085-01a,		Detail application of protective shields, saddles, and inserts at hangers for each type of insulation and

Submittal Number	Section Name	Product Type	
TWES 15061-01)		hanger.	
TWES-15111-01	GENERAL-DUTY VALVES FOR PLUMBING PIPING	Bronze gate valves	
TWES-15112-015	GENERAL-DUTY VALVES FOR HVAC PIPING	Brass ball valves.	
TWES-15112-092, -042, -072, -073		Iron globe valves.	
TWES-15112-06		Bronze swing check valves.	
TWES-15112-013		Bronze gate valves.	
TWES-15112-071		Iron gate valves.	
TWES-15112-071a		Iron gate valves.	
TWES-15127-02 (see TWES 15127-03)		METERS AND GAGES FOR HVAC PIPING	Liquid-in-glass thermometers.
TWES-15127-03	Thermowells.		
TWES-15127-03a	Thermowells.		
TWES-15127-04 (see TWES 15127-03)	Dial-type pressure gages.		
TWES-15127-05 (see TWES 15127-03)	Gage attachments.		
TWES-15127-09	V-cone flowmeter.		
TWES-15127-09b	Flow calculation		
TWES-15127-09c	Flow meter and pressure gauge		
TWES-15127-010	thermocouple		
TWES-15127-011	pressure transmitter		
TWES-15127-012	pressure scrubber		
TWES-15140-02	DOMESTIC WATER PIPING		Copper tube and fittings
TWES-15140-06			Ductile iron pipe and fittings (?)
TWES-15140-01, 03 to 06			Galvanized steel pipe and fittings
TWES-15140-07		Piping joining materials	
TWES-15181-07a	HYDRONIC PIPING	Y Strainer	
TWES-15181-07b		Y Strainer	
TWES-15182-03 to 06	STEAM AND CONDENSATE PIPING	Pressure-reducing and safety valve.	
TWES-15182-07		Y Strainer	
TWES-15182-08		Blowdown Separator	
TWES-15182-01, 02		Steam trap.	
TWES-15182-09		Air vent and vacuum breaker.	
TWES-15182-09a		Vacuum breaker	
TWES-15182-011		Certificate of inspection	
TWES-15182-012		Gate valves	
TWES-15186-01		STEAM CONDENSATE PUMPS	Electric-driven steam condensate pumps
TWES-15186-01a			connector
TWES-15189-03	HVAC WATER TREATMENT	Biocide chemical-feed equipment and controls.	
TWES-15189-01		Water softener	
TWES-15189-11		tubing	

Submittal Number	Section Name	Product Type
TWES-15518-01	FIRE-TUBE BOILERS	Boiler sales form
TWES-15520-01	FEEDWATER EQUIPMENT	Feedwater sales form
TWES-15550-01	BREECHINGS, CHIMNEYS, AND STACKS	Building-heating-appliance chimneys.
TWES-15550-02		Drawing of flue stack
TWES-15710-01	HYDRONIC AND STEAM HEAT EXCHANGERS	Shell-and-tube heat exchanger
TWES-15900-01B	HVAC INSTRUMENTATION AND CONTROLS	NEMA control panels
TWES-15900-01C		NEMA Remote I/O panel
TWES-15900-07		automated ball valve package
TWES-15900-010 (see TWES-15900-01C)		NEMA Remote I/O panel
TWES-15900-016 (see TWES-15900-01B)		NEMA control panels
TWES-16073-01		HANGERS AND SUPPORTS FOR ELECTRICAL SYSTEMS
TWES-16073-05 (see TWES-15061-05)	welding certificates	
TWES-16074-03 (see TWES-15061-05)	VIBRATION CONTROLS FOR ELECTRICAL SYSTEMS	welding certificates
TWES-16075-01	ELECTRICAL IDENTIFICATION	Identification of power and control cables.
TWES-16075-01		Identification for conductors.
TWES-16075-02		Warning labels and signs.
TWES-16075-01		Equipment identification labels.
TWES-16120-01	CONDUCTORS AND CABLES	Building wires and cables rated 600 V and less.
TWES-16120-02 to 06		Connectors, splices, and terminations rated 600 V and less.
TWES-16130-01	RACEWAYS AND BOXES	Hinged-cover enclosures and cabinets
TWES-16140-01 to 05	WIRING DEVICES	Receptacles, receptacles with integral GFCI, and associated device plates.
TWES-16410-01 to 02	ENCLOSED SWITCHES AND CIRCUIT BREAKERS	For each type of enclosed switch, circuit breaker, accessory, and component indicated.
TWES-16442-01 to 02	PANELBOARDS	Distribution panel boards
TWES-16442-03 to 04		Lighting and appliance branch-circuit panel boards
TWES-16461-01	LOW-VOLTAGE TRANSFORMERS	Dry-type distribution transformers rated 600 V and less, with capacities up to 1000 kVA
TWES-16491-01	FUSES	Cartridge fuses rated 600-V ac and less for use in control circuits, enclosed switches and enclosed controllers

Appendix D: Original ANTARES Data Collection Plan

As the Allen Bradley Data Acquisition System will not be fully installed for the testing, ANTARES has formulated a plan to measure the temperature, flow, and pressure at several points within the steam system using instruments already installed on the trailer. This section is a summary of the equipment that is to be used and the data that must be logged in order to determine the system's overall performance.

The purpose of the plan is to gather data on the performance of the steam generation portion of the TWES system. Although diesel fuel will be used in the combustor for the test, the hot flue gas will generate steam in the same manner as if biomass fuel were combusted in the furnace. The key items that will be calculated are the energy input and energy output of the steam generation process. The data points used to calculate those key items are described in this section along with how the data will be logged during the testing.

Data Points

There is already measuring equipment installed at several points within the TWES trailer. Table D-1 below shows a list of that equipment, and Figure D-2 shows the placement of the equipment within the trailer's flow schematic. Table D-1 also shows the minimum and maximum range of the output values for the measurement devices. The flow meter and pressure transducers output data in the form of 4–20 mA signals. These can be connected to portable data loggers (e.g., a 4-channel Hobo logger made by Onset). The data logger records the mA output of the meter on a selectable interval (between 15 and 3600 seconds between readings; 15 s is recommended for this application) in a format exportable to an Excel spreadsheet. Once the data is in spreadsheet form, the mA data can be scaled appropriately to determine the corresponding flow and pressure values.

The thermocouple probe outputs the temperature values directly, and as a result no scaling is needed.

Table D-1. Installed Measurement Equipment

	Output	Min Output Value (4 mA)	Max Output Value (20 mA)	Scaling Relationship	Equipment Needed
Veris Accelabar flow meter	4–20 mA	210 lb/hr	2,100 lb/hr	118 lbs/hr per mA (linear)	4–20 mA input cable, data logger with stereo input
Pressure transmitter (PX-880-100GI)	4–20 mA	0 psig	100 psig	6.25 psig per mA (linear)	4–20 mA input cable, data logger with stereo input
Pressure transmitter (PX-880-300GI)	4–20 mA	0 psig	300 psig	18.75 psig per mA (linear)	4–20 mA input cable, data logger with stereo input
Thermocouple probe	temperature values	–	–	no scaling needed	data logger capable of measuring a type K thermocouple signal

To attach the data logger to the measurement equipment on the trailer, an input cable similar to the one in Figure D-1 below needs to be installed on each of the flow meter and pressure transmitters. This would enable the device to transmit the mA signal to the data logger.



Figure D-1. 4–20 mA Input Cable

The thermocouple probes already installed on the trailer would need to have a special data logger that is capable of measuring the type K thermocouple signal. ANTARES also suggests that an additional thermocouple be installed on the ductwork between the furnace and the HRSG to allow a better understanding of the furnace gas flow rate and properties. This would need a data logger capable of measuring the thermocouple output, as well. The type of signal output by the thermocouple is given in the specifications (there are multiple signal output types depending on the type of conductors used in the probe).

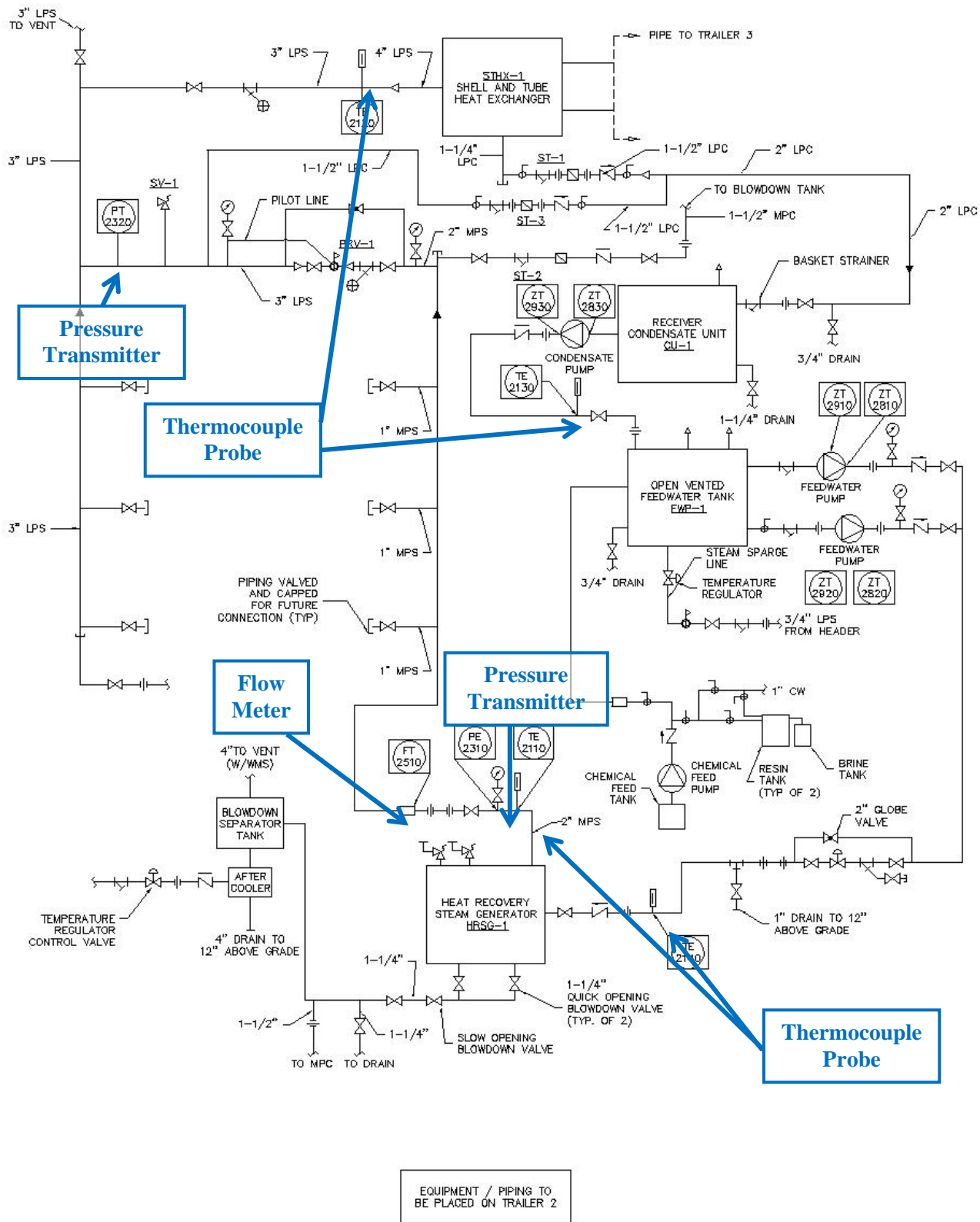

STEAM AND HOT WATER SYSTEM FLOW SCHEMATIC
NOT TO SCALE

Figure D-2. Measurement Points within the TWES Trailer

The data that is logged will be first used to find the instantaneous steam enthalpies at several points within the system. This will be done using a spreadsheet calculator referencing the IAPWS IF-97 steam tables.

The logged data will also be used to determine the furnace gas temperature immediately prior to the HRSG. Such pre-heat-exchange temperatures are a direct function of the amount of excess air present at the burner (i.e. air-to-fuel ratio). For this reason, the fuel flow rate and the furnace gas temperature will be used to calculate the total flue gas flow rate through the system. Fuel flow rate is to be determined as an average based on the height of fuel remaining in the fuel oil tank at several points during the test period.

Figure D-3 presents the relationships between furnace gas flow rate and furnace gas temperature for selected fuel flow rates. These relationships were derived from heat and mass balance modeling performed with Thermoflex software, and will be used to convert the fuel flow rate and furnace temperature information into furnace gas flow rates.

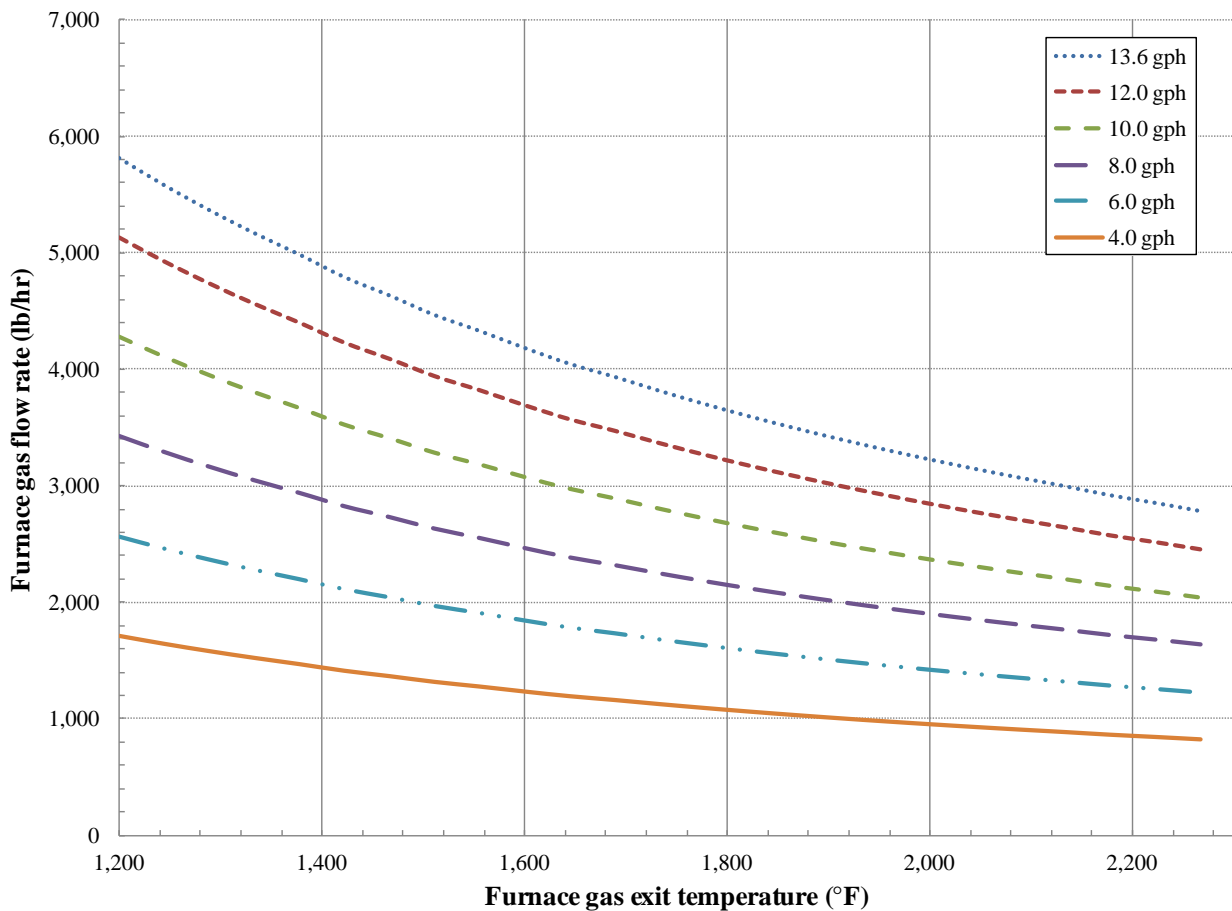

Figure D-3. Relationship Between Air Flow, Fuel Flow, and Furnace Gas Temperatures

Empirically, these relationships are described by the following equation:

$$\dot{m} = 6.943 \times \dot{d} \times (-1.0196 \times 10^{-8} \times T^3 + 7.1144 \times 10^{-5} \times T^2 - 0.182 \times T + 195.1)$$

where:

$$\begin{aligned} \dot{m} &= \text{mass flow rate of flue gas } \left(\frac{\text{lb}}{\text{hr}}\right) \\ \dot{d} &= \text{volumetric flow rate of diesel fuel (gph)} \\ T &= \text{furnace gas exit temperature } (^{\circ}\text{F}) \end{aligned}$$

Measurement of the flue gas exit temperature from the HRSG will allow the system heat transfer profile to be better understood and will provide a check on the steam condition measurements taken elsewhere in the system.

Overall, these parameters in combination with measured fuel flow rates will allow calculation of the overall fuel to steam efficiency of the TWES continuously for the testing and commissioning period.

Other Data Points

As a check to the logged data points the following data points will be recorded during the test on a regular interval:

- Pressure gauges (top of boiler, feedwater pump, low pressure side of PRV station)
- Temperature gauges (top of boiler, feedwater pump, low pressure side of PRV station)
- Steam flow meter (digital readout of Veris Flow Meter)
- Water flow meter (temporary installation of Fuji Electric Flow Meter to record makeup water flow)

These other data points will be hand-recorded on a 5-min interval and will be used to back-check/verify numbers calculated by the data captured by the loggers.

Kane May KM 700 Methodology to Determine Excess Air and Boiler Efficiency The KM 700 combustion or flue gas analyzer is used to measure the efficiency of the combustion process from the burner. This is not the same as the boiler efficiency because it does not take into account additional losses, such as the heat losses from the case of the boiler and heat transfer losses.

“The objective of a boiler is to burn the hydrogen contained in the fuel with oxygen from the atmosphere to produce heat. Combustion efficiency analyzers exploit the fact that by knowing the fuel (and its chemical composition) and measuring the flue gas temperature and either the oxygen or carbon dioxide level¹¹ the combustion efficiency of the boiler can be calculated. On some boilers, the settings can then be adjusted to maximize the combustion efficiency.”[3]

Ideally, the maximum burner combustion efficiency would be achieved with 0% oxygen in the flue and the lowest flue gas temperature. In practice, an allowance must be made for differences

¹¹The flue gas temperature, oxygen and carbon dioxide levels were measured during testing

in fuel composition, atmospheric pressure, wind direction, boiler demands etc. As a result, a 0% oxygen level in the flue is simply not practical for real-life applications. [3]

If the oxygen level is set too low and something changes within the boiler, the combustion process can become 'fuel rich' when there is insufficient oxygen for all of the fuel to burn. This can cause high levels of carbon monoxide (CO) to be generated, and in extreme cases, fuel entering the boiler flue can ignite outside the combustion chamber. Typically oxygen readings may be in the range of 3% to 5% for a natural gas boiler, 5% to 8% for an oil boiler, and 8% to 10% for a coal-fired boiler.[3] The analyzer used in the testing doesn't have a CO sensor and recorded oxygen readings between 6.3% and 10.7% when the Becket blower was the only source of combustion air.

The actual amount of excess air in the boiler flue is calculated by using the measured value of oxygen in the exhaust from the combustion analyzer, along with the following equation:

$$\text{Excess Air in the Boiler Flue} = \left(100 \times \frac{20.9\%}{20.9\% - O_{2m}\%}\right) - 100\%$$

Where $O_{2m}\%$ = the measured value of oxygen in the exhaust.

For example, if the measured level of oxygen in the exhaust is 0%, then:

When $O_{2m}\% = 0\%$

$$\text{Excess air} = \left(100 \times \frac{20.9\%}{20.9\% - 0\%}\right) - 100\%$$

$$\text{Excess air} = \left(100 \times \frac{20.9\%}{20.9\%}\right) - 100\%$$

$$\text{Excess air} = (100 \times 1) - 100\%$$

$$\text{Excess air} = 0\%$$

For example, if the measured level of oxygen in the exhaust is 5%, then:

When $O_{2m}\% = 5\%$

$$\text{Excess air} = \left(100 \times \frac{20.9\%}{20.9\% - 5\%}\right) - 100\%$$

$$\text{Excess air} = \left(100 \times \frac{20.9\%}{15.9\%}\right) - 100\%$$

$$\text{Excess air} = (100 \times 1.31) - 100\%$$

$$\text{Excess air} = 31\%$$

Appendix E: Additional Test Data

As discussed in Section 4 of the report, some of the data that was recorded by the data loggers was deemed inaccurate for several reasons. Temperature data for the LPS on all three testing days, as well as the temperature data for the MPS on the second and third testing days were determined to be too low. For the steam to be in a gaseous state at those recorded temperatures, the pressure in the pipes would have to have been below atmospheric pressure, which is not likely given the application. ANTARES believes that the thermocouple wire that was used between the thermocouples and the data loggers may have had a bad connection. A contributing factor may have been that the data loggers were removed for data download and then replaced every day. This movement with the data loggers may have led to loosening of the connections and led to inaccurate signals.

Similarly, the pressure values recorded in the LPS and MPS lines were too low and didn't correspond with values that were recorded manually by AFRL during the trailer's operation. It was later determined the pressure transducers were not connected to a required power source. ANTARES determined the resulting data were floating signals, induced by surrounding charges. The LPS and MPS pressure floating signals follow the same shape profile, indicating that they were probably subjected to the same types of charges. Discussions with the Onset technical support indicated this is plausible.

Additionally, it appears that the MPS flow rates recorded were also floating or drifting values. This is evident because the flow rates do not correlate to the operation of the trailer. Furthermore, the flow values closely follow the same profile shape that the LPS and MPS pressure recordings exhibit, both of which were determined to be inaccurate. Similarly to the pressure transducers, the flow meter also requires power for accurate read-outs.

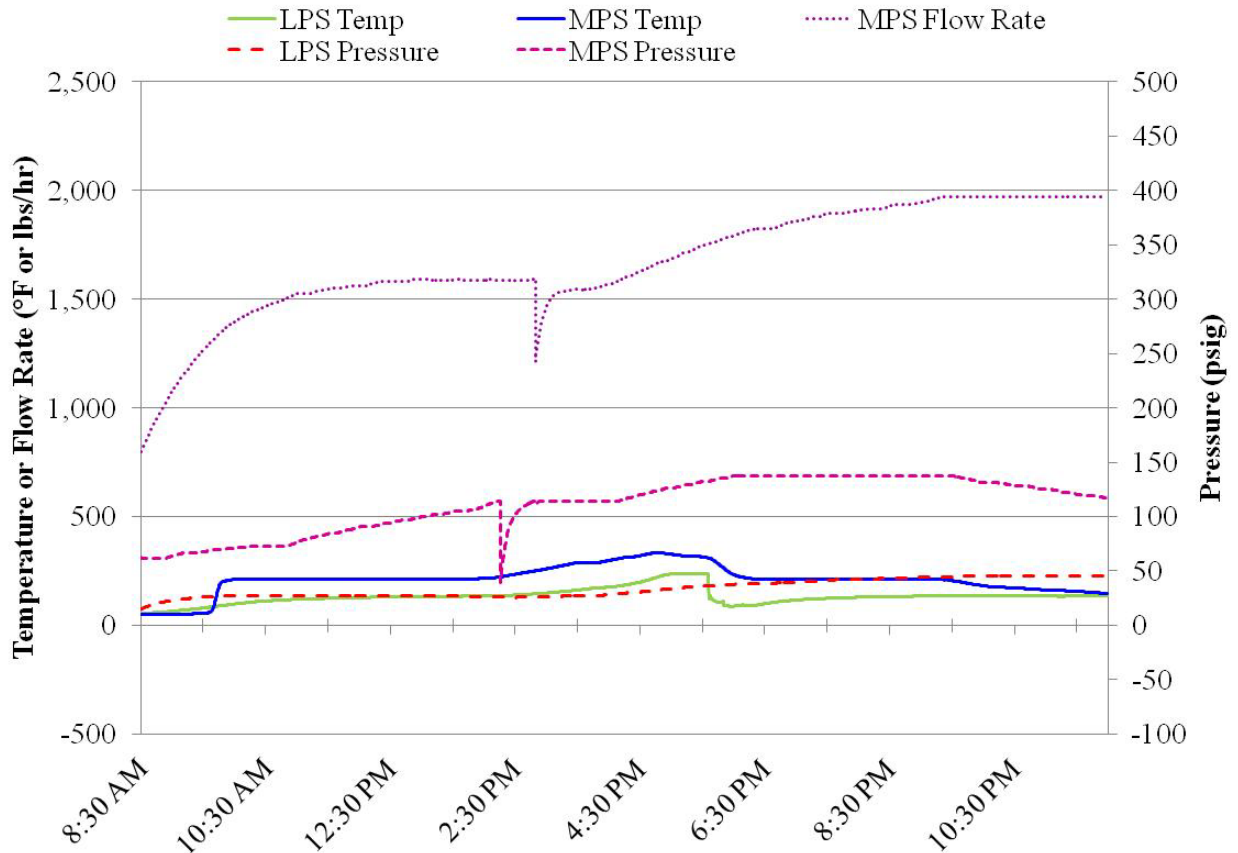

Figure E-1. Temperature, Pressure, and Flow Profiles for LPS and MPS during Testing on December 12, 2011

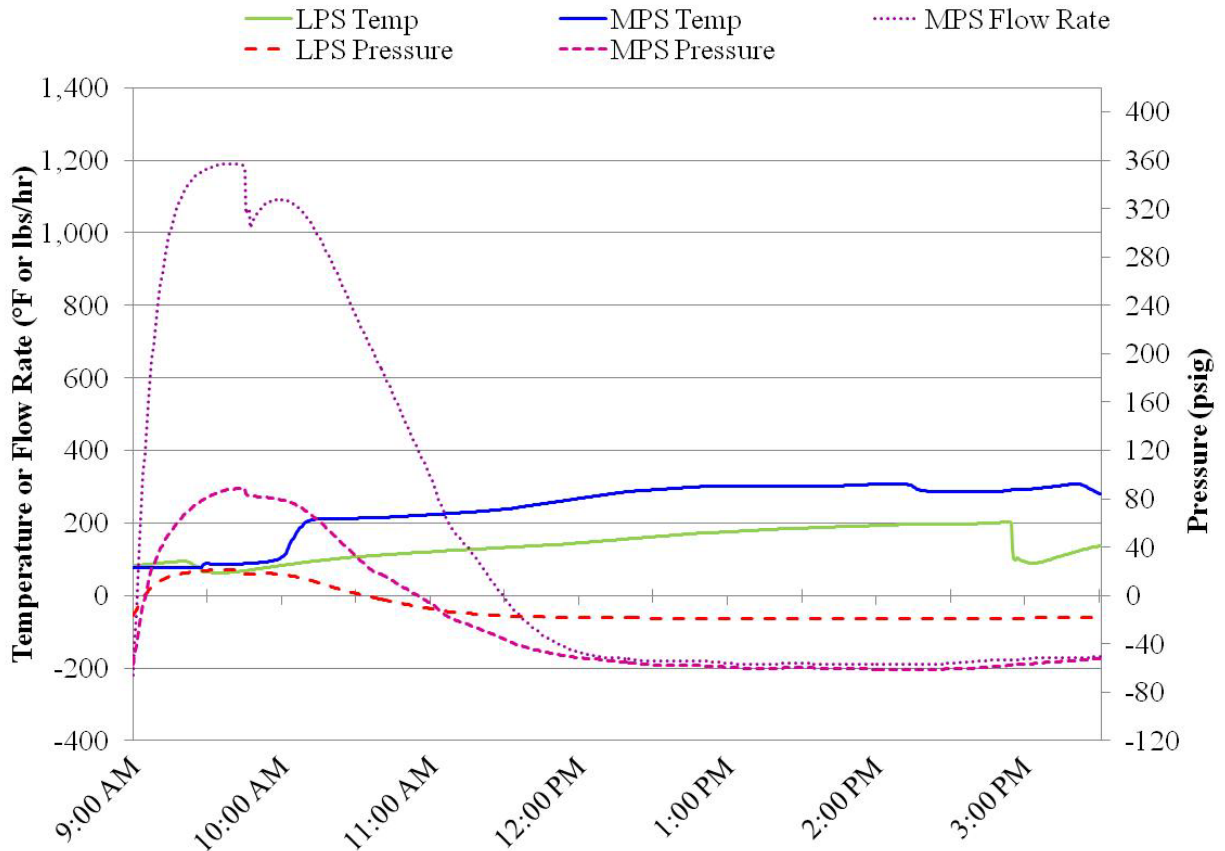

Figure E-2. Temperature, Pressure, and Flow Profiles for LPS and MPS during Testing on December 13, 2011

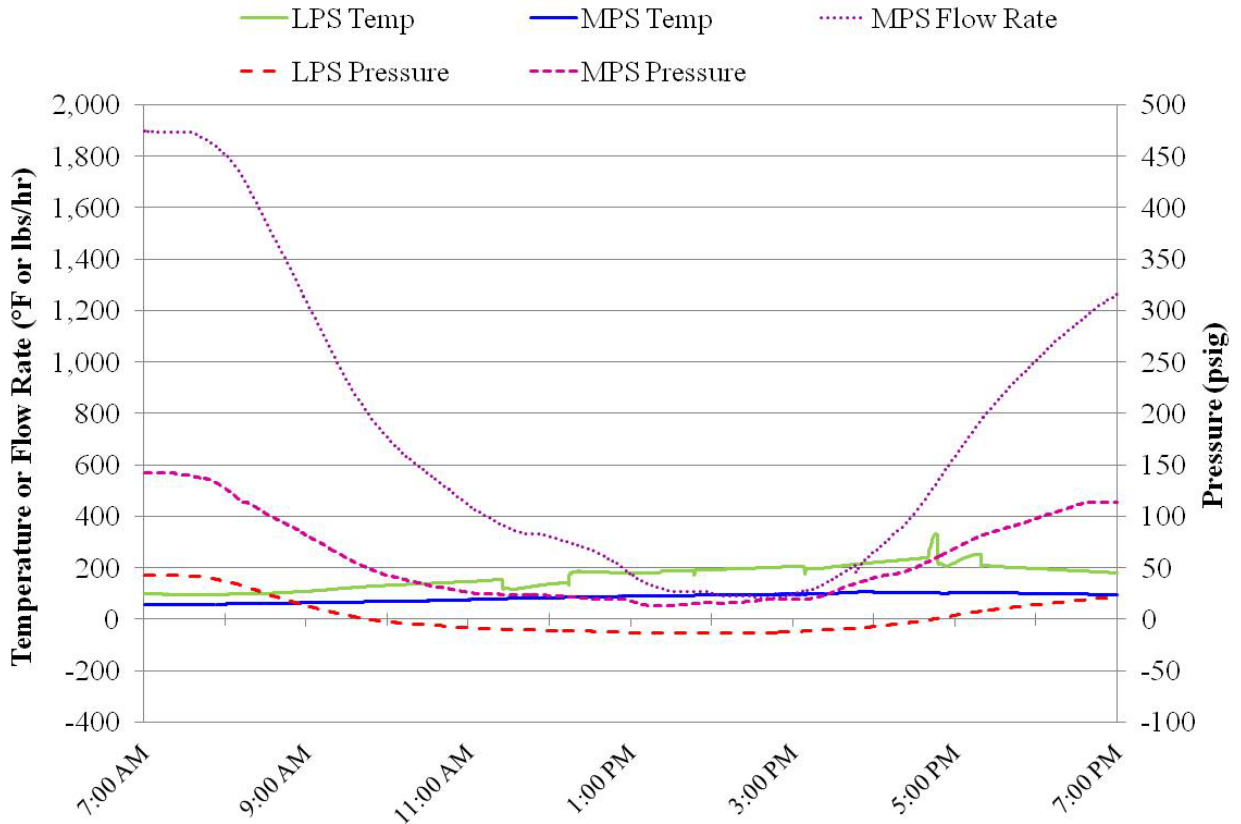

Figure E-3. Temperature, Pressure, and Flow Profiles for LPS and MPS during Testing on December 15, 2011

Appendix F: AFRL Test Plan

Transportable Waste-to-Energy System (TWES)
—
Operating the Steam Generator with Diesel Burner

Test Plan
(Unclassified)



1 December 2011

Prepared by: Lt Thomas Bowen
DSN 523-3725

Air Force Research Laboratory
Airbase Automation Branch
Robotics Research and Development
Tyndall AFB, FL

Table of Contents

I. Test Plan Information	iii
II. Technical Review Board (TRB) Approval	iv
III. Safety review Board (SRB) Test Plan Review, Coordination, and Approvals.....	v
1. Overview and Purpose	2
1.1. Purpose of Project	2
1.2. Purpose of Tests	2
1.3. System Description	2
1.4. Success Criteria.....	3
1.5. Background Information	3
1.6. Previous Related Work.....	3
2. Test Equipment Description	4
3. Method Of Tests	5
3.1. Test Approach and Procedures.....	5
3.2. Test and Safety Go/No Go Lists for Test Equipment and Operations.....	6
3.3. Operating Parameters for Tests	7
4. Test Management.....	8
4.1. Program Schedule	8
4.2. Responsible Test Organization.....	9
4.3. Liability Determination	9
4.4. Project Management Personnel and Responsibilities.....	9
4.5. Personnel Involved in the Tests	10
5. Safety and Operational Risk management.....	10
5.1. Risk Assessment.....	10
5.2. Risk Control Measures	11
5.2.1. Personal Protection Equipment.....	11
5.2.2. Emergency Equipment:.....	11
5.2.3. Fire Protection:.....	11
6. Mishap Procedure and Reporting.....	11
Bibliography	13
Appendix A: Test Safety Plan.....	A-1
Attachment 1: AFRL Form 29 - Test Safety Mishap Worksheet.....	A-9
Attachment 2: AFRL Form 12 - Test Hazard Analysis	A-10
Attachment 3: Emergency Telephone Number Reference List	A-15
Instructions for placing local phone calls at Tyndall AFB	A-15
Attachment 4: Personal Acknowledgement Form	A-16
Attachment 5: Material Safety Data Sheets (MSDS)	A-17
Appendix B: Test LOG SHEET	B-1

I. TEST PLAN INFORMATION

INITIAL MISSION/PROJECT TEST PLAN TITLE TWES - Operating the Steam Generator with Burner		CONTROL NUMBER 01-TWES	MISSION DATE 6-9 Dec 2011
SUPPORTING AGENCIES (Customers) DOE FEMP		CASE FILE NUMBER QF503016	PROJECT JON GOVT0035
RX PROGRAM NAME Transportable Waste-to-Energy System (TWES) for Sustainable Energy Generation	PROGRAM MANAGER Lt Thomas Bowen, AFRL/RXQES	TEST START DATE 6 Dec 2011	TEST END DATE 9 Dec 2011
PRINCIPLE INVESTIGATOR Lt Thomas Bowen, AFRL/RXQES	SIGNATURE	PHONE NUMBER (850) 283-3725	DATE
TEST DIRECTOR Mr. Randy Brockman, Ctr, AFRL/RXQES	SIGNATURE	PHONE NUMBER (850) 283-2784	DATE

II. TECHNICAL REVIEW BOARD (TRB) APPROVAL

AFRL TECHNICAL REVIEW BOARD			
DATE: 1 December 2011		PROGRAM MANAGER (name, symbol, phone): Lt Thomas Bowen, AFRL/RXQES, (850) 283-3725, DSN 523-3725	
PROGRAM TITLE: Transportable Waste to Energy System (TWES)			
TEST PLAN DOCUMENT NO.	TECHNICAL RISK LEVEL:	TEST ORGANIZATION/AGENCY	
01-TWES	Low	RXQES	
DESCRIPTION OF TEST: This program's goal is to develop a robust energy management system that converts solid wastes into usable heat, reducing the accumulation refuse, and enhancing base security. The Transportable Waste to Energy System (TWES) pneumatically conveys shredded waste material to a large furnace where it is disposed through high temperature burning. Furnace exhaust exits through a heat recovery steam generator. This experiment will characterize the ability to convert the chemical energy from the furnace into steam.			
REMARKS: This experiment will only test the ability to convert heat from a diesel burner into steam rather than from burned waste as originally intended.			
TRB MEMBERS NAME, SYMBOL, TITLE	SIGNATURE AND DATE	CONCUR WITH RECOMMENDED RISK	
		YES	NO
TRB CHAIRMAN: RXQE, Airbase Automation Branch, Acting Chief: Brian Skibba		<input checked="" type="checkbox"/>	<input type="checkbox"/>
RXQES Section Chief: Capt Krystal Walker		<input checked="" type="checkbox"/>	<input type="checkbox"/>
Safety Representative: Perry Mitchell, GS-12		<input checked="" type="checkbox"/>	<input type="checkbox"/>

AFRL Form 19B *Technical Review Board*

III. SAFETY REVIEW BOARD (SRB) TEST PLAN REVIEW, COORDINATION, AND APPROVALS

RXQ Det 2 Safety Review Board (SRB)

Residual Safety Risk Level = LOW		
NAME, GRADE AND TITLE	CONCUR WITH RISK LEVEL? (mark with "X")	SIGNATURE AND DATE
<i>RXQ Det 2 SRB Chair</i> Perry V. Mitchell, GS-12 Unit Safety Manager AFRL/RXQ	X	
RXQE Airbase Automation Branch (Acting) Chief Brian Skibba, AFRL/RXQE	X	
RXQES Section Chief Capt Krystal Walker, AFRL/RXQES	X	
Test Director Randy Brockman, Ctr, AFRL/RXQES	X	
Principle Investigator Lt Thomas Bowen, AFRL/RXQES	X	

TEST APPROVAL AUTHORITY (TAA):

If the Residual Safety Risk Level is LOW, then branch chief signature or higher is required; if MEDIUM, then division chief or higher; if HIGH, then the plan must be sent to AFRL/SE by the RX Test Lead

NAME, GRADE AND TITLE	SIGNATURE AND DATE
RXQE, Airbase Automation Branch, Acting Chief: Brian Skibba	

1. OVERVIEW AND PURPOSE

1.1. Purpose of Project

Deployed military bases generate significant amounts of waste. Current practices often rely on hauling the trash by local contractors. Due to concern for base security, there are periods of time when removal is not feasible. At these times, accumulation out-paces removal. Managing the bulky, randomly sized materials becomes the great challenge for both short-term and long-duration deployed DoD operations (Jantzer and Gerdes 2004).

The goal of the TWES project is to develop a robust energy management system that thermally converts non-hazardous solid wastes into usable energy, thereby reducing the accumulation of waste, and enhancing base security.

1.2. Purpose of Tests

The current series of tests will evaluate the performance of the newly constructed steam generator post integration with the existing TWES furnace. These series of tests will demonstrate conversion of chemical energy from a diesel burner into useful thermal energy in the form of steam. The system will act like a large calorimeter, yielding measureable data by comparing the energy input against the useful energy output.

The term “experiment” may be used interchangeably with the word “test” in this document. Both refer to the same procedures.

1.3. System Description

The TWES integrates a novel furnace and a steam generator. In the future, additional equipment will be added to generate electricity and to produce chilled water. Because solid waste comes in various sizes and shapes, the first step involves size-reduction by shredding. A vacuum conveying system draws the shredded materials into a hopper.

The shredded solid fuel is then metered into a forced circulation air stream and into a helically coiled pipe inside the furnace. The hot coil ignites incoming fuel. Once burning, the fuel radiates heat, maintaining the system temperature. The full length of the pipe acts as a heat reverberating surface to achieve complete fuel combustion. After exiting the coil pipe, gases enter a secondary combustion chamber for increased residence time before exiting the exhaust stack. This describes the operation of the TWES furnace.

A new heat recovery steam generator (HRSG) has been integrated with the TWES furnace. After this modification, combustion exhaust passes through the steam generator (boiler) it to produce steam. Fuel and air flow rates, temperatures, and pressures will be collected to evaluate the system performance.

For this particular test, a diesel burner will produce the required heat input in lieu of operating the furnace. System performance will be measured from in and outputs from the burner and HRSG rather than the waste stream fuel, furnace and HRSG.

1.4. Success Criteria

The test will be considered successful when the TWES furnace and steam generator are able to produce any steam as identified visually via the steam vents (threshold 1), 240lb/hr at 250 psig at 205°C (threshold 2) and 480lb/hr (objective). Data collection and analysis will report the efficiency of energy conversion, and will provide a complete heat and material balance for the HRSG. The goal is an efficiency of 50% or higher, defined as (thermal energy of steam)/(Total energy input)*100%. Operational challenges will be addressed. Ideally a steady state solution would be achieved, but that may require time beyond a normal duty day, and therefore will not be required for experiment success.

1.5. Background Information

The concept of the helical coil furnace has been demonstrated with several simple models and numerous hours of testing by Clean Flame Energy (CFE) of Scarborough, Maine. The furnace concept was refined to practice and patented by DiSanto (1992) of CFE. The thrust of the current effort is advanced technology development, the design and testing of a prototype. AFRL/RXQE reviewed, tested, and confirmed the basic principles to insure the furnace would function effectively. The issues evaluated include, pneumatic conveying, pressure drop, fan sizing, fuel feed mechanism, and fuel characterization. These steps were necessary because CFE burned pre-shredded rubber while the current design must process and burn wood, paper, and plastic. The early models had minimal instrumentation and data collection. AFRL/RXQE built and tested a prototype furnace on a flat bed semi-trailer. Now, with the HRSG built on a second trailer, the two sub-systems are ready for integration and testing.

1.6. Previous Related Work

Through its many reports, studies, and initiatives, the DoD recognizes a need to continue improving its management of solid wastes (Circeo, et al., 1997; Paisley, 1997; Martel, 2003; Jantzer and Gerdes, 2004; and NFESC, 2000). Several of these studies demonstrate that a large percentage of the waste at a deployed base is comprised of packaging materials. Increasing base self-sufficiency and improving solid waste treatment are priorities for military planners (Gerdes, G. L. et. al, 2008). The Air Force has investigated deployed based waste treatment, including solid wastes (Circeo, et al., 1997 and Paisley, 1997). Data for the different waste streams was compiled from existing reports and estimates. The Harvest Falcon deployment unit was the basis for the Air Force's study.

The Army completed two studies of waste treatment at base camps in the Balkans. The first was conducted at Eagle Base in Bosnia and Camp Bondsteel in Kosovo (Martel, 2003). The second study evaluated waste handling at the same camps as well as Camp Bulwark in Bulgaria (Jantzer and Gerdes, 2004). In the past, base camp solid waste was sent to local landfills. Policy and practice changes were implemented after a scavenging local national was accidentally crushed to death by a US garbage truck. Solid waste was then burned in enclosed pit incinerators or air-curtain incinerators. Due to the inefficiency, complete combustion was not achieved, size reduction not maximized, nor was the energy recovered. The resulting ash and scrap was removed from the site by dump trucks. The smoke annoyed both the soldiers and local residents. Hazardous or otherwise inappropriate wastes were manually separated before combustion.

Emission data from previous TWES furnace testing was collected and analyzed, with results published and presented at NAWTEC17 (Lindsey, *et al.*, 2009).

2. TEST EQUIPMENT DESCRIPTION

At its current stage of development, the TWES consists of two flat bed semi-trailers with the following major equipment:

Furnace (6,000 lbs) – The furnace was built based on a patented helical coil combustion chamber design. Detail design work was performed by Mike Sawyer and Bill Lewis at AFRL/RXQES. It was fabricated by several sub-contractors with final assembly by AFRL Robotics.

- Outer body – Hurst Boiler, 21971 U.S. Highway 319 N., Coolidge, GA 31738, (877) 994-8778, www.hurstboiler.com
- Insulation – Thermal Products Company, Inc., 4520 S. Berkeley Lake Rd., Norcross, GA 30071, Phone: 770-662-0456
- Internal tube – Philadelphia Pipe Bending, 4165 N. 5th Street, Philadelphia, PA 19160, (800) 523-0182
- Exhaust stack and cover – AFRL/RXQO Metal Shop
- Assembly and Instrumentation – Robotics Rapid Prototype Shop

As previously stated, the furnace consists of two combustion chambers. The primary combustion chamber is a well-insulated, helically coiled pipe. Initiated with JP-8 fuel, the hot pipe ignites the solid fuel (waste material). Heat produced is transferred back to the pipe in order to maintain the system at a constant temperature. The secondary chamber increases residence time.



Figure 1: TWES Trailer #1 with solid fuel handling equipment; the furnace has been move to Trailer #2.

Shredder (5,000 lbs) – The primary purpose of the shredder is to convert wood, paper, and plastic of variable size and shape to one that is uniform. The shredder was manufactured in Germany by Vecoplan, LLC. Its US distributor is Vecoplan, LLC, 5708 Uwharrie Rd, Archdale, NC 27263, (888) 738-3241 or (336) 861-6070.

Fuel Hopper/Conveyor System (2,850 lbs) – The fuel conveyor system was built by Material Systems Engineering, Inc. (MSE), 898 South State Road 39, Danville, IN 46122, (317) 745-7263. This conveyor draws shredded, solid fuel into a hopper by vacuum. The vacuum filling method can handle dense and lightweight shredded materials. The conveyor system slowly releases the shredded solid fuel into an air stream and then pneumatically conveys it into the furnace.

Air Compressor – The air compressor is a Sears Craftsman. It operates with 6.5HP, twin cylinder, oil-free, 240V, 60 gal tank, pressure regulator, 11.5 SCFM at 90psi 480 VDC/200 Amp Power Transformer and Drop Cord. The air compressor supplies air to clean the air filters in the fuel hopper, which fills by vacuum.

Laptop Computer – The computer is used to control air and fuel rates and to monitor furnace temperatures, air pressures, oxygen content, and fuel flow rates.

Heat Recovery Steam Generator – The HRSG was manufactured by Hurst Boiler, 21971 U.S. Highway 319 N., Coolidge, GA 31738, phone: (877) 994-8778, www.hurstboiler.com in AD 2009. It is rated to produce up to 1200 lb/hr of saturated steam @ 250 psig when the furnace burns 500 lb/hr of mixed, solid municipal waste. Parameters for the current experiments are listed in Section 3.3.

Water Conditioning Equipment – The steam generator system and its water conditioning equipment were selected and integrated by Antares Group, Inc., 4351 Garden City Drive, Suite 301, Landover, MD 20785, phone (301) 731-1900. The majority of the fabrication was completed by Davis Mechanical Service, Inc., 6689 Old Collamer Road, East Syracuse, NY 13057, phone (315) 463-9999 in 2009 and 2010.

The steam generator integrated with the furnace and accompanying equipment is installed on a second flatbed semi-trailer as shown in Figure 2.



**Figure 2: TWES Trailer #2 with steam generation equipment attached to furnace;
The HRSG is on the aft end of the trailer.**

3. METHOD OF TESTS

3.1. Test Approach and Procedures

Final fabrication and system checkout as completed are listed below:

- Functional testing of boiler feed-water pumps, condensate tank and control sequences
 - Pumps operated as designed and transferred water from condensate tank to main boiler
- Hydrostatic test
 - Tested piping to operating pressure of 250 psig
- Verify steam traps are free of debris
 - Water flowed through the traps
- Verify operation of thermocouples and pressure transducers (excluding furnace)
 - Infrared thermometer will manually verify temperature readings; pressures will be cross referenced
- Train operators
- Inspect and repair instrumentation
- Complete a final safety review
- Commission the equipment, inspecting it to ensure it is ready for operation.

Testing will be conducted using a diesel burner to mimic burned waste feed from a bare base. The rate of steam generation will be recorded along with key burner parameters, namely fuel, airflow, and temperature. Energy and mass balances will be evaluated to verify system performance. Procedures for the steam generator will be developed based on knowledge of the system and safe engineering principles. The “Startup Checklist for Steam Generator and Supporting Equipment” is tabulated in Appendix A of this test plan.

Test Location – The flatbed trailers will be parked on Airbase Operating Surface’s Test Pad within AFRL Tyndall’s 9700 compound. The furnace trailer will be no closer than 50 feet from any building during operation. Please refer to the image below.



Figure 3: TWES Testing Location in relation to Building 9738

3.2. Test and Safety Go/No Go Lists for Test Equipment and Operations

Confirm that the status of these tasks and conditions are acceptable.

	Approved Test Plan
	Approved Safety Plan
	Safety review completed and equipment meets requirements
	All planned operations personnel on-site, available, and operational
	At commissioning, verify the HRSG has been filled with water and is free of air pockets.
	HRSG & Support equipment meet operational checks
	Weather is acceptable.
	All personnel briefed on project objectives, equipment operation, their assignment, safety hazards, and safety zones
	Personal Protective Equipment in place
	First Aid kit ready for use

3.3. Operating Parameters for Tests

Parameter	Target Value(s) (Subject to change)
Fuel Type	Diesel Fuel
Fuel Flow Rate	4-13.6 gal/hr
Heat content	140,000 BTU/hr per gal/hr
Heat content (biomass)	15,817 kJ/kg solid waste; Assuming 50% system efficiency for steam
Water supply to boiler	1.2 GPM, 70 gal/hr (once-through flow path)
Steam production	480 lb/hr @ 250 psig, 205 °C (saturated)

The only controllable parameter is the flow rate, and thus heat input, to the diesel burner. The flow will be step increased by moving the sliding head position from 3 to 10 . The burner has two firing settings, one high and one low for every head position. The low fire will be used initially as a functional checkout at which point all changes will be made with the burner in high fire. At each increment the steam production will stabilize before proceeding to the next level. The fuel flow rate is not monitored digitally; rather the fuel consumption will be averaged by measuring the consumption within the diesel tank with respect to time. The plate placement relation to flow is published in the Beckett CF-1400 operator’s manual. The following table demonstrates the manner by which manual data will be recorded. Note that a coordinated time will also be recorded to facilitate comparison to the digitally procured data.

Appendix B contains a copy of the data recording log sheet.

The table below describes the data measuring equipment.

	Output	Min Output Value (4 mA)	Max Output Value (20 mA)	Scaling Relationship	Equipment Needed
Yokogawa flow meter	4 – 20 mA	210 lb/hr	2,100 lb/hr	118 lbs/hr per mA (linear)	4 – 20 mA input cable, data logger with stereo input
Pressure transmitter (PX-880-100GI)	4 – 20 mA	0 psig	100 psig	6.25 psig per mA (linear)	4 – 20 mA input cable, data logger with stereo input
Pressure transmitter (PX-880-300GI)	4 – 20 mA	0 psig	300 psig	18.75 psig per mA (linear)	4 – 20 mA input cable, data logger with stereo input
Thermocouple probe (exhaust stacks; furn and boiler)	°F	–	–	no scaling needed	data logger capable of measuring a type K thermocouple signal
Onset Computer HOBO Data logger (U12-006)	–	–	–	–	Measuring equipment

A data logger will collect the information during the test and record them in relation to coordinated time. The flow meter measures steam flow in lbs/hr, the pressure transmitters will measure the steam pressures, and the thermocouples will relay temperature in °F. The instrumentation was calibrated prior to equipment transfer to AFRL and the thermocouples will be verified with a non-contact infrared thermometer. These points will be taken once every five seconds.

4. TEST MANAGEMENT

4.1. Program Schedule

Due to the nature of research and development efforts, the final test schedule will be adjusted as needed to accommodate equipment performance. The experimental work is also subject to operational and environmental restrictions and favorable weather conditions. The following proposed schedule represents the major developmental goals and test goals.

Table 1: Project Schedule

Task Description	start date	end date
Project Start	10/2011	
TASK 1: Complete Trailer 2	10/2011	11/2011
Final construction review; Punch list	10/2011	11/2011
TASK 2: Commissioning & Testing	11/2011	12/2011
Perform Safety Review & Write Experiment Plan	10/2011	11/2011
Prepare Equipment - supplies, calibrations, training	11/2011	11/2011
Operational testing of Trlr2 & Trailer 1	12/2011	12/2011
Run Performance & Emissions Experiments	12/2011	12/2011

TASK 3: Develop Final Documentation	11/2011	12/2011
Project End		12/2011

Planned Test Start and End Dates – This test plan will cover all design and field-testing of the Furnace System for the period of October 2011 through December 2011. The experiments should be completed before the stated end date.

4.2. Responsible Test Organization

AFRL/RXQES Section is responsible for conducting the experiment with Antares Group, Inc. fulfilling a supporting role.

4.3. Liability Determination

AFRL/ RXQ is the determining agent in the event of a mishap and associating appropriate liability.

4.4. Project Management Personnel and Responsibilities

Engineering Development Section (RXQES) Chief:
 Capt Krystal Walker (krystal.walker@tyndall.af.mil)
 Phone: (850) 283-9702, DSN 523-9702 Fax: (850) 283-9710

Project Officer: Lt Thomas Bowen (thomas.bowen@tyndall.af.mil)
 Phone: (850) 283-3725, DSN 523-3725 Fax: (850)283-9710

Principle Investigator: Lt Thomas Bowen (thomas.bowen@tyndall.af.mil)
 Phone: (850) 283-3725, DSN 523-3725 Fax: (850)283-9710

Test Director: Randy Brockman (randall.brockman.ctr@tyndall.af.mil)
 Phone: (850) 283-2784, DSN 523-2784 Fax: (850)283-4327

Chief: The Engineering Development Section Chief is responsible for the overall enforcement of this test plan. She is further responsible for assigning only properly trained personnel to execute this plan. A Safety Review Board (SRB) will be accomplished with key personnel during the coordinating and review process of this test plan. All personnel will be briefed on all hazards associated with this operation. The Chief, RXQES, will delegate this responsibility to the Project Officer.

Principle Investigator/Project Officer: The Principle Investigator/Project Officer is responsible for providing the coordinated and approved test plan covering the technical aspects and sequence of events. The test plan will be coordinated and reviewed by key personnel to include the Section Chief, Principle Investigator/Project Officer, and Test Director.

Test Director: The Test Director is responsible for overall on-site supervision of the test trials, to include taking the necessary actions to protect all personnel, equipment, and facilities from damage resulting from a test under his or her control. The Test Director ensures all personnel have been thoroughly briefed on specific duties, responsibilities, and hazards involved. The Test Director will maintain positive control over all test trials and essential personnel within the confine of the test site.

4.5. Personnel Involved in the Tests

Test Personnel: Test Personnel are AFRL personnel and their contractors. The AFRL Robotics Research Group is responsible for test setup, execution, and post-test reporting procedures according to the test plan. Test personnel from the Robotic Research Group performing the tests will have the proper technical and safety training. Test Personnel will be chosen and assigned based on the test plan, the Test Director’s recommendations, and the Test Director’s needs.

Casuals: These are persons not normally part of the project/operation but have duties that require their presence, such as quality assurance, safety, and data collection personnel. There may also be personnel visiting the site primarily to observe the tests. Visitors will not be permitted inside any hazard zone during test operations. Visitors will be briefed on how to work safely around the equipment.

Project Support Personnel: Each individual assigned to this project is responsible for compliance with the applicable provisions of this test plan. Any person observing an unsafe act or condition will immediately stop the test and notify the Test Director. The Test Director will not resume the test until the situation is safely resolved.

5. SAFETY AND OPERATIONAL RISK MANAGEMENT

Safety will have the highest priority during this project. Prior to each test scenario and/or event, the assigned Project Officer, Test Director, or their designated representative will brief participants on duties, demonstration procedures, and safety precautions identified here. An overview of safety considerations is discussed below with additional information given in the “Test Safety Plan for TWES Operating the Steam Generator with Diesel Burner” is attached as Appendix A. If any participant observes an unsafe condition, the experiment will be suspended immediately. The Project Officer will evaluate the specific hazard and take appropriate action before resuming the experiment.

5.1. Risk Assessment

The Experiment Hazard Analysis for the experiments of this project is detailed in the corresponding Experiment Safety Plan in Appendix A. A Risk Assessment Matrix Value was determined for each hazard. An overall risk value was determined for the experiments by averaging the individual hazard values based upon governing document: AFI 91-202/AFMC Sup1, AFRL Sup.1 (AFRL, 2008). The resulting value was 13.2, indicating LOW risk. A summary of the potential hazards is listed in Table 2. A discussion of common field experiment hazards is also included in the safety plan.

Table 2: Potential Hazards Identified and Assessed

HAZARD	ANALYSIS
Heat transfer on items that may get hot during operation	<ul style="list-style-type: none">• Ensure furnace condition is acceptable before use and is located 50 feet from any building• The furnace has signs posted to warn of heat hazard• Protective gloves for high temperature work
Compressed gases	<ul style="list-style-type: none">• All compressed air and gas equipment to be

	<p>kept in good condition.</p> <ul style="list-style-type: none"> • Replace worn gas lines, loose fittings, etc.
Steam	<ul style="list-style-type: none"> • Steam will be vented to a safe location • Post warning signs at vent location • Monitor pressures during experiment • Pressure relief valve is installed.
Condensate	<ul style="list-style-type: none"> • Condensate will dump to a safe location • Post warning signs at dump location • Monitor condensate flow rates during testing
Other hazards	<ul style="list-style-type: none"> • Post signs warning of potential hazards

5.2. Risk Control Measures

All test operations will comply with applicable regulations and base safety plans. Control measures are discussed in Appendix A.

5.2.1. Personal Protection Equipment

Appropriate Personal Protection Equipment (PPE) for the tasks will be available. PPE will be used when necessary. PPE may include:

- Eye protection (safety glasses)
- Ear protection
- Work gloves (natural cloth or leather, nothing that could melt)
- Insulated gloves
- Hardhat
- Steel toed shoes
- Ear protection
- Face shields
- Fire resistant overcoats

5.2.2. Emergency Equipment:

A first aid kit will be available at the command post for the tests. "911" emergency service is available by phone call. Local emergency support (fire) provided by the Tyndall AFB is located at the entrance to the Silver Flag exercise area, which is within 5 miles, and medical within 12 miles (main base) of the experiment site. This proximity should allow response times under 15 minutes.

5.2.3. Fire Protection:

Two class ABC fire extinguishers will be available on the trailers.

6. MISHAP PROCEDURE AND REPORTING

Mishap Investigation Responsibility (Mishap Accountability) - AFRL/RXQES will investigate any mishaps and will recommend corrective action to prevent future mishaps. Mishap accountability in no way implies blame or mishap responsibility. Safety mishap investigation is for the sole purpose of mishap prevention.

If a piece of equipment is damaged or destroyed, the mishap class is determined by the value of the damage. The equipment to be used in this project is valued at between \$500,000 and \$800,000, which correlates to a Class B mishap, if a mishap should occur.

Prior to the test, a copy of the AFRL Test Safety Mishap Worksheet (AFRL Form 29) will be filled with names and phone numbers. The sheet is located in Appendix A. The unit safety manager will be notified when testing will occur so he can be prepared to fulfill his responsibilities if called.

Initial mishap response will begin as soon as the mishap is reported by the support personnel to the test director. If personnel are injured, the first responder to the injured personnel will give aid, and if applicable, call 911. The test director will then notify the principal investigator and then isolate and confine the area of damage for investigation and retrieval of equipment. The test director will arrive at the confined area to initiate AFRL Form 29, mentioned above. AFRL Form 29 will be completed as completely as possible to include detailed information regarding personnel injury and equipment damage/destruction. The principal investigator will notify the safety representative listed on the Form 29 within eight hours of the mishap and all other personnel listed on the form.

After the mishap is investigated, and governed by the value of the equipment damage, a Safety Investigation Board may be initiated by the AFRL commander (AFRL/CC).

BIBLIOGRAPHY

- AFRL, *Safety – The US Air Force Mishap Prevention Program*, Air Force Instruction (AFI) 91-202, Aug 1998, AFMC Supplement, Nov 11, 2005, AFRL Supplement 1, Apr 11, 2008.
source: <https://explorer.ebs.afrl.af.mil/livelink/lisapi.dll/af91-202sup1.pdf?func=doc.Fetch&nodeid=15809835&docTitle=af91%2D202sup1%2Epdf&vernum=7> (accessed 10/27/2010) .
- Circeo, L.J. et al., *Next Generation Base Waste Processing System Phase I Report*, a report prepared by the Georgia Institute of Technology, School of Architecture Construction Research Center, for Tyndall AFB, August 1997.
- Gerdes, G. L. et. al., “Hydrothermal Processing of Base Camp Solid Wastes to Allow Onsite Recycling,” for US Army ERDC/CERL, September 2008.
- Jantzer, A. L. (Buchart-Horn) and Gerdes, G. L. (CERL), “Base Camp Solid Waste Characterization Study,” Draft report, for US Army ERDC/CERL, Contract DACA90-02-D-0085, DO 0028, Dec 20, AD 2004.
- Lindsey C. et. al., “Emissions Performance of a Novel Combustor Burning Shredded Wood,” NAWTEC17-2344, *Proceedings of 17th Annual North American Waste-to-Energy Conference*, Chantilly, Virginia, USA: ASME, May 18-20, 2009.
- Martel, C. James, *Analysis of the Waste Management Practices at Bosnia and Kosovo Base Camps*, Final Report for the US Army Corps of Engineers, Office of the Chief of Engineers, April 2003.
- NFESC UG-2039-ENV, *Qualified Recycling Program (QRP) Guide*; July 2000 (NOTAL)
- Paisley, M.A., Anson, D., “Biomass Gasification for Gas Turbine Based Power Generation”, Presented at the International Gas Turbine & Aeroengine Congress & Exhibition, 1997.
- M. Sawyer, *Furnace System Operators’ Guide*, AFRL-RX-TY-TM-2009-4591, Tyndall AFB, FL: Air Force Research Laboratory, Dec 2009.

APPENDIX A: TEST SAFETY PLAN

Test Safety Plan for Transportable Waste-to-Energy System (TWES) - Operating the Steam Generator with Diesel Burner

Location: Pavements Test strip SE of Building 9738, Tyndall AFB, FL 32403

Date: 28 November 2011

Project Officer: Lt Thomas Bowen, AFRL/RXQES Robotics Group

List of Attachments

Attachment 1: AFRL Form 29 - Test Safety Mishap Worksheet.....	A-9
Attachment 2: AFRL Form 12 - Test Hazard Analysis	A-10
Attachment 3: Emergency Telephone Number Reference List	A-15
Attachment 4: Personal Acknowledgement Form	A-16
Attachment 5: Material Safety Data Sheets (MSDS)	A-17

List of Tables

Table A1: TWES Startup Checklist for Steam Generator and Supporting Equipment	A-3
Table A2: Risk Assessment Matrix, Master List with Scoring Values	A-5
Table A3: MSDS List for This Series of Tests	A-17

1.0 SCOPE

This Safety Plan refers to the operation of Air Force Research Laboratory (AFRL) equipment and supporting equipment for the Transportable Waste to Energy System (TWES), attachments, and associated payloads. The purpose is to demonstrate the integration of the steam generator with the existing furnace. Refer to 6.4 "Site Control Measures" for medical response information and overall site guidelines.

2.0 PROJECT ORGANIZATION

The Robotics Group (AFRL/RXQES) shall designate a Project Officer (PO) to have overall control of the project involving the use of AFRL/RXQES personnel and equipment. The Project Officer ensures that this safety plan is followed and has the authority to stop operations whenever necessary. The Project Officer will designate a qualified Test Director (TD) to oversee operations in his absence and to be responsible for site supervision and operations. The Project Officer will coordinate with the Test Director to ensure the safety of all personnel involved on the project. Personnel designations including Project Officer and Test Director are listed in Section 4.2 Responsible Individuals.

3.0 SAFETY:

The Test Director will conduct a daily safety briefing prior to operation of any system for an experiment. All personnel entering the system operating areas will attend this briefing or receive a personal briefing. The briefings will be conducted by the Project Officer and Test Director.

3.1 The safety briefing will cover the following areas at a minimum: work hours, work area boundaries, safety exclusion zone areas, planned operations, and equipment.

3.2 Safety Procedures: These procedures will be posted in a visible location.

3.2.1 General Procedures:

3.2.1.1 The Test Director will specify safety exclusion zones or limited access zones appropriate for the system in operation. The limited access zone is 5ft from hot surfaces or other dangers, unless a safety cover is installed. These areas will be selected in coordination with the unit safety manager.

3.2.1.2 The Project Officer will provide personnel with emergency contact phone numbers. This information is listed in Attachment 3.

3.2.1.3 Personnel will only enter a safety exclusion zone after coordinating with the Test Director.

3.2.1.4 All TWES operations on the site will be discontinued immediately should an unforeseen hazardous condition develop which may pose a danger to life or property. Any personnel may initiate a safety shutdown.

3.2.1.4.1 The Project Officer will determine when safe to resume testing.

3.2.1.5 All operations will cease immediately upon the approach of an electrical storm or other severe weather conditions.

3.2.1.6 If a fire occurs that might involve hazardous or explosive materials, all personnel will immediately evacuate to a designated safe area after initiating emergency shutdown procedures.

3.2.1.7 Visitors and observers will be located in areas designated for observers. These areas do not need to be marked and may be moved at the discretion of the Project Officer or Test Director. The Project Officer and Test Director will be aware of any personnel in the area of the experiment.

4.0 TWES OPERATIONS

4.1 General Procedures:

- 4.1.1 During system operations there will be a minimum of two personnel present at all times. One individual will be responsible for the role of lookout to assist the TWES equipment operator with situational awareness.
- 4.1.2 Prior to the start of daily operations, there will be an inspection of the equipment to be used in the operation. Startup procedures and a checklist for the furnace portion of the equipment are given in the document *Furnace System Operators' Guide* (Sawyer, M., Dec 2009). Table A3 shown below has the TWES Startup Checklist for Steam Generator and Supporting Equipment.

Table A3: TWES Startup Checklist for Steam Generator and Supporting Equipment

√	<i>Check Item Required</i>
	At commissioning, verify the HRSG is filled with water and is free of air pockets.
	Perform Maintenance Check per the schedule assigned to each piece of equipment
	Verify feed water reservoir level is acceptable. Normally it should be full at startup.
	Mark safety zones with cones or other indicators

- 4.1.3 Ensure that the exhaust stack is located at least 50 ft (horizontally) from the nearest building, or personal vehicles, as stated in *Furnace System Operators' Guide* (Sawyer, M., Dec 2009).
- 4.1.4 TWES equipment operations will follow the guidelines and experiment objectives in the Project Test Plan.

4.2 Responsible Individuals:

The following individuals are the key points of contact for any safety concerns or issues with TWES operations by AFRL/RXQES personnel or equipment during the experiment.

Principle Investigator/Project Officer: Lt Thomas Bowen
(thomas.bowen@tyndall.af.mil), Phone: (850) 283-3725

Test Director: Randy Brockman (randall.brockman.ctr@tyndall.af.mil), Phone:
(850) 283-2784

Program Manager, Robotics Group Lead: Walt Waltz
(walter.waltz@tyndall.af.mil), Phone: (850) 283-3725

RXQES Engineering Development Section (RXQES) Chief: Capt Krystal Walker
(krystal.walker@tyndall.af.mil), Phone: (850) 283-9702

RXQE Airbase Automation Development Branch Chief (Acting): Brian Skibba
(brian.skibba@tyndall.af.mil), (850) 283-2784

RXQ Chief Engineer: Jim Hurley (james.hurley@tyndall.af.mil), Phone (850) 283-
6310

RXQ Airbase Technology Division Chief: Albert N. Rhodes, P.h.D
(albert.rhodes@tyndall.af.mil), Phone (850) 283-6274

5.0 HAZARD ANALYSIS:

5.1 Potential Hazards Identified: Table A4 formalizes the scoring method for assessing the risk of individual operational hazards of an event or a system. First, a group of skilled people must identify all hazards with a system of event. Then each hazard must be evaluated for (1) its probability of occurrence and (2) its severity if it did occur. Together, these are used to select a hazard number from Table A4. The numbers range from 1 to 20. A score of 1 indicates a problem that is certain to occur and is extremely severe. Number 20 indicates a hazard that is very unlikely to occur and has negligible severity. Once all hazards are identified and scored, an overall score can be generated for the event or system as a whole by averaging the individual hazard values. Risk values are based upon the governing document: AFI 91-202/AFMC Sup1, AFRL Sup.1, Apr 11, 2008.

A Risk Assessment Matrix Value was determined for each operational hazard of the TWES “Operating the Steam Generator with Diesel Burner” experiments. An overall risk value for the experiment is analyzed as LOW risk. The risks of burns, boiler over-pressurization, fires, and weather concerns vary in severity from marginal to catastrophic and probability from improbable to remote. With hazard mitigation efforts in place the highest score value achieved is a 10 (refer to Table A2). These hazard assessments are detailed in AFRL Test Hazard Analysis Form 12, in Attachment 2 of this document.

Table A4: Risk Assessment Matrix, Master List with Scoring Values

	HAZARD SEVERITY CATEGORY			
	<i>Catastrophic-I</i> Could result in death, permanent total disability or system/ facility loss >\$1M	<i>Critical-II</i> permanent partial disability, injuries or illness that may result in hospitalization of >3 personnel, or system/ facility loss >\$200K but <\$1M	<i>Marginal-III</i> injury or illness resulting in >1 day of lost work, system/facility loss >\$20K but <\$200K	<i>Negligible- IV</i> injury or illness not resulting in lost work time, system /facility loss >\$2K but <\$20K
HAZARD PROBABILITY				
FREQUENT-A Will occur and likely to occur often*	1	3	7	13
PROBABLE-B Will occur several times*	2	5	9	16
OCCASIONAL-C Likely to occur sometime*	4	6	11	18
REMOTE-D Unlikely, but possible to occur*	8	10	14	19
IMPROBABLE-E Highly unlikely to occur*	12	15	17	20

Notes:

- Table A4 and Generalized Risk Levels were taken from AFI 91-202, AFRL Sup.1 (Apr 11, 2008); Modified based on RXQES template file text rearranged for clarity.
- * = “During the life of an specific item or during an specific event”

5.2 Generalized Risk Levels Based on Table A4: Risk Assessment Matrix, Master List with Scoring Values:

Low risk: Experiments or activities that present no greater risk than normal operations after appropriate controls have been applied. For the example matrix above, this would be 10-20.

Medium risk: Experiments or activities that present a greater risk to personnel, equipment, or property than normal operations even after the appropriate controls have been applied. For the example matrix above, this would be 6-9.

High risk: Experiments or activities that present a significant risk to personnel, equipment, or property even after all precautionary measures have been taken. For the example matrix above, this would be 1-5. [AFI 91-202, AFRL Sup.1 (Apr 11, 2008) lists level 5 as only a medium risk.]

During the safety review, personnel will use these guidelines, expert opinions, and engineering analysis to assign risk levels to each identified hazard, individual test event, and the test as a whole.

5.3 Additional Hazards: In addition to the specific operation hazards identified, a number of potential general physical hazards that may be encountered during field activities. These hazards include existing objects and terrain, lifting heavy objects, solar non-ionizing radiation, heat and cold stress.

5.3.1 Existing Objects and terrain can present hazards in the form of: holes, ditches; precariously positioned objects (e.g., drums, cables, boards) that may fall or cause an individual to trip; sharp objects and building rubble such as nails, metal shards, rebar, and broken glass; slippery surfaces.

5.3.2 Lifting Heavy Objects: field personnel may be exposed to injury caused by lifting heavy objects. Mechanical and hydraulic assists will be used whenever appropriate to minimize lifting dangers. Useful guidelines for lifting include: if possible, bend your knees and lift with your legs, not your back, but always maintain a stable, comfortable posture; lift heavy objects slowly and deliberately, not with a grab and jerk motion; avoid turning while lifting; turn while you are upright.

5.3.3 The potential for both heat and cold related disorders or conditions can occur in many common situations. Cold early morning temperatures can give way to warm daily temperatures, resulting in heavy perspiration within protective clothing. As temperatures cool again in the evening, the potential for cold related disorders or conditions can occur. Personnel should be aware of the potential for this occurrence and should monitor workers accordingly. The physical conditions that effect heat/cold exposure disorders or conditions are physical fitness, alcohol or drug use, and disease. The Test Director should monitor daily weather conditions and prescribe appropriate clothing and work-rest schedules as required to minimize the possibility of any cold stress-related problems.

6.0 HAZARD MONITORING AND CONTROL

6.1 Training: All personnel who perform field activities at the described site must review the Test Plan and Safety Plan (i.e. this document and its parent document). The Project Officer will document, with the personal acknowledgement receipt (Attachment 4), that personnel involved onsite have received and reviewed the Test Plan. In addition, a daily safety briefing conducted by the Test Director shall be held onsite prior to each day's activities to reiterate the health and safety requirements or to inform site personnel of upcoming operations and safety requirements.

6.1.1 Hazard Communication: All personnel involved in the handling or use of hazardous materials have received training per requirements AFI 90-821, Hazard Communication. MSDS sheets of hazardous materials anticipated for use during the experiment are included as Attachment 5.

6.2 Personal Protective Equipment: Appropriate personal protective equipment for the task will be provided and/or available on site. This equipment may include: safety

glasses, ear plugs/muffs, rubber/leather gloves, face shields, fire retardant suits, and steel-toed shoes (ANSI #Z41.1-1972-75).

6.3 Emergency Equipment: In spite of safety and health training, the use of appropriate protective equipment, and exercise of due caution by members of the operation team, the possibility exists for injury and illness in the field. In order to provide emergency assistance to sick or injured workers, the following supplies and equipment will be available at the experiment site: first aid kit and ABC fire extinguishers.

6.4 Site Control Measures: Personnel will not work alone during the operations. The experiment site is close to an occupied building so additional assistance and telephones are available. Other site control measures include the following:

- The operations team led by the Test Director will perform tasks specified in Table A3 “TWES Startup Checklist for Steam Generator and Supporting Equipment”.
- The Test Director will provide safety training to new operators. Working through the start-up checklists will provide renewed reminders of safety issues.
- All experiments will be conducted at AFRL on Tyndall AFB near building 9738. Operators will be familiar with the site. Visitors will be given a site orientation. Visitors who help with experiments will be informed of the Test Plan.
- Emergency phone numbers for the fire department, ambulance service, nearest medical clinic/hospital, along with the quickest traveling route to the hospital shall be available to field staff while in the field.
- A daily safety briefing will be conducted at the beginning of each shift, whenever new personnel arrive at the job site, as site conditions change, or when deemed necessary. They will be conducted by the Test Director to discuss pertinent site safety topics.
- The Test Director will ensure that appropriate PPE is available and used.

6.5 Sanitation: Sanitary toilet facilities and potable water are available in the buildings near the test site and are available for all field personnel.

7.0 EMERGENCY RESPONSE

7.1 Site Emergency Response: It is the objective of this Safety Plan to minimize hazards and accidents. The following information is provided to ensure that personnel respond to an emergency in a calm, reasonable manner.

7.2 Telephone contact Reference List: Emergency Medical Support is available by calling “911.” Attachment 3 provides a list of the emergency/reference numbers to be used during the field operations.

7.3 First aid may be performed if it does not endanger the safety of the individual administering first aid. A first aid kit will be available at the command post for the tests.

7.4 Fire Emergencies: In the event of a fire, attempts will be made to extinguish it with an ABC class fire extinguisher if safe to do so. Fire extinguishers will be located on the equipment trailers. If the fire appears to be growing out of control, the following steps will be performed:

- The field team should depart the site to a designated safe area
- AFRL Project Officer will verify all persons are present.
- Notify the Fire Department
- Remove vehicles if safely possible
- Remove flammable field solvents and fuels if safely possible
- Await fire-fighting forces.

Attachment 1: AFRL Form 29 - Test Safety Mishap Worksheet

AFRL Test Safety Mishap Workshop

(to be completed within 8 hours of mishap)

General Information

AFRL/RXQES Robotics

Title of Test Program: TWES: Transportable Waste-to-Energy Sys. Date of Mishap: _____

Principle Investigator/Engineer: Lt Thomas Bowen (850) 283-3725 Time of Mishap: _____

Location of Mishap: _____

Brief Narrative: _____

Personnel

Injuries? Yes No If Yes: Military Gov't Civilian Contractor Non Gov't

How many people were injured? _____ Hospitalization required? _____

Extent of Injuries? (be as specific as possible; name) _____

Name of responding emergency organization: _____

Point of contact at organization (name and number): _____

Name of clinic or hospital where injured was taken : _____

Property

Property Damage? Yes No If Yes: Government Contractor Non-Gov't

Was Property Damaged? Yes No If Yes, Approximate dollar cost: _____

Extent of Damage: _____

Mishap Notification Record

	Name/Phone	Date/Time
AFRL TD Safety:	<u>Perry V. Mitchell, (850) 283-0995</u>	
Group Leader:	<u>Walt Waltz, (850) 283-3725</u>	
Section Chief:	<u>Capt Krystal Walker, (850) 283-9702</u>	
Branch Chief:	<u>Brian Skibba (Acting), (850) 283-2784</u>	
Division Chief:	<u>Albert N. Rhodes, (850) 283-6274</u>	
SRB Chair: (safety)	<u>Perry V. Mitchell, (850) 283-0995</u>	

Additional Notes: _____

Attachment 2: AFRL Form 12 - Test Hazard Analysis

TEST HAZARD ANALYSIS (THA)		PAGE 1 of 1	
PROGRAM TITLE: Transportable Waste to Energy		TEST PLAN # 01-TWES	
PROGRAM MANAGER: Lt Thomas Bowen	PHONE NUMBER: 3-3725	HAZARD CATEGORY: Critical LOW	DATE: 9 Nov 2011
PREPARED BY: Lt Thomas Bowen	PHONE NUMBER 3-3725	OFFICE SYMBOL: AFRL/RXQES	
<p>TEST HAZARD: Hazard #1 – Condensate/Steam/High Temperature Burns</p> <p>CAUSE:</p> <ol style="list-style-type: none"> 1. Personnel enter condensate dump/ steam vent areas 2. Valve/piping leaks expose personnel to steam/condensate unexpectedly 3. Personnel contact un-insulated high temperature areas <p>EFFECT:</p> <ol style="list-style-type: none"> 1. Injury 2. Equipment or property damage <p>CONTROLS/MINIMIZING PROCEDURES</p> <ol style="list-style-type: none"> 1. A 5 foot safety exclusion zone will be maintained around all condensate dump and steam vent areas. Personnel will only enter the exclusion zone after prior coordination with the Test Director. 2. Only qualified personnel will repair leaks occurring during a test. 3. Temporary insulation will be applied to high temperature areas (with the exception of the boiler and furnace), and personnel will wear thermal insulating gloves rated to 400 deg F (temperature of piping). <p>CORRECTIVE ACTIONS/EMERGENCY PROCEDURES:</p> <ol style="list-style-type: none"> 1. Depending on the severity of burn, discontinue experimenting and initiate emergency shutdown. 2. If necessary the heat source will be removed, valves closed upstream and opened downstream to relieve pressure around leak during repair. 3. If a mishap occurs appropriate procedures as outlined in safety plan will be initiated. 4. If serious injuries have occurred, call 911 and perform necessary first aid (if safe) until EMS arrives. 5. File a mishap report. <p>RISK ASSESSMENT MATRIX VALUE: Control measures of excluding non-essential personnel in the area to reduce risk to observers. Trained personnel are aware of equipment operation and hazard areas, and will be wearing pertinent personal protective equipment. Hazard severity is Critical for burns. Hazard probability is remote: Risk assessment matrix value of II/D 10 (LOW risk)</p>			
THA ACCEPTED: YES	SRB CHAIRMAN: Perry Mitchell	SIGNATURE:	DATE:

AFRL FORM 12 Sep 00 Prescribing Directive: AFRLI 99-103

TEST HAZARD ANALYSIS (THA)		PAGE 1 of 1	
PROGRAM TITLE: Transportable Waste to Energy		TEST PLAN # 01-TWES	
PROGRAM MANAGER: Lt Thomas Bowen	PHONE NUMBER: 3-3725	HAZARD CATEGORY: Catastrophic LOW	DATE: 9 Nov 2011
PREPARED BY: Lt Thomas Bowen	PHONE NUMBER 3-3725	OFFICE SYMBOL: AFRL/RXQES	
<p>TEST HAZARD: Hazard #2 –Over-pressurization of Vessel (Boiler)</p> <p>CAUSE:</p> <ol style="list-style-type: none"> 1. Blockage in steam lines 2. Steam production greater than steam discharge 3. Liquid level in vessel drops below accepted limits <p>EFFECT:</p> <ol style="list-style-type: none"> 1. Injury or death 2. Equipment or property damage <p>CONTROLS/MINIMIZING PROCEDURES</p> <ol style="list-style-type: none"> 1. Personnel will monitor boiler pressure level to ensure it remains within safe limits. 2. Personnel will adjust heat input to match system limitations, if necessary. 3. Personnel will monitor and adjust liquid flow rate to match boiler needs. 4. Personnel will ensure a constant boiler liquid level, and will call for heat source removal if level dips below safety level. <p>CORRECTIVE ACTIONS/EMERGENCY PROCEDURES:</p> <ol style="list-style-type: none"> 1. Depending on severity of over-pressurization, begin emergency shutdown procedures. 2. If a mishap occurs appropriate procedures as outlined in safety plan will be initiated. 3. If serious injuries have occurred, call 911 and perform necessary first aid (if safe) until EMS arrives. 4. File a mishap report. <p>RISK ASSESSMENT MATRIX VALUE: Control measures of excluding non-essential personnel in the area to reduce risk to observers. Trained personnel are aware of equipment operation and hazard areas, and will be wearing pertinent personal protective equipment. Hazard severity is Catastrophic due to potential for death and total system loss. Hazard probability is Improbable: Risk assessment matrix value of I/E 12 (LOW risk)</p>			
THA ACCEPTED: YES	SRB CHAIRMAN: Perry Mitchell	SIGNATURE:	DATE:

AFRL FORM 12 Sep 00
Prescribing Directive: AFRLI 99-103

TEST HAZARD ANALYSIS (THA)		PAGE 1 of 1	
PROGRAM TITLE: Transportable Waste to Energy		TEST PLAN # 01-TWES	
PROGRAM MANAGER: Lt Thomas Bowen	PHONE NUMBER: 3-3725	HAZARD CATEGORY: Critical LOW	DATE: 9 Nov 2011
PREPARED BY: Lt Thomas Bowen	PHONE NUMBER 3-3725	OFFICE SYMBOL: AFRL/RXQES	
<p>TEST HAZARD: Hazard #3 – Electrical Fire</p> <p>CAUSE: 1. Electrical Short, system or subsystem component failure</p> <p>EFFECT: 1. Injury 2. Equipment or property damage</p> <p>CONTROLS/MINIMIZING PROCEDURES 1. Electrical system will be tested prior to experiment 2. Single source of electricity for quick disconnect</p> <p>CORRECTIVE ACTIONS/EMERGENCY PROCEDURES: 1. Begin emergency shutdown procedures, including immediate disconnection of electrical source. 2. Extinguish fire if possible with ABC fire extinguishers, or if unable, call fire department and evacuate personnel. 2. If a mishap occurs appropriate procedures as outlined in safety plan will be initiated. 3. If serious injuries have occurred, call 911 and perform necessary first aid (if safe) until EMS arrives. 4. File a mishap report.</p> <p>RISK ASSESSMENT MATRIX VALUE: Control measures of excluding non-essential personnel in the area to reduce risk to observers. Trained personnel are aware of equipment operation and hazard areas, and will be wearing pertinent personal protective equipment. Hazard severity is Critical due to potential for injury with the electrical and water combination. Hazard probability is Improbable: Risk assessment matrix value of II/E 15 (LOW risk)</p>			
THA ACCEPTED: YES	SRB CHAIRMAN: Perry Mitchell	SIGNATURE:	DATE:

AFRL FORM 12 Sep 00
Prescribing Directive: AFRLI 99-103

TEST HAZARD ANALYSIS (THA)		PAGE 1 of 1	
PROGRAM TITLE: Transportable Waste to Energy		TEST PLAN # 01-TWES	
PROGRAM MANAGER: Lt Thomas Bowen	PHONE NUMBER: 3-3725	HAZARD CATEGORY: Critical LOW	DATE: 9 Nov 2011
PREPARED BY: Lt Thomas Bowen	PHONE NUMBER 3-3725	OFFICE SYMBOL: AFRL/RXQES	
<p>TEST HAZARD: Hazard #4 –Fuel (Diesel) Fire</p> <p>CAUSE:</p> <ol style="list-style-type: none"> 1. Improperly handled/stored fuel 2. Fuel leak <p>EFFECT:</p> <ol style="list-style-type: none"> 1. Injury 2. Equipment or property damage <p>CONTROLS/MINIMIZING PROCEDURES</p> <ol style="list-style-type: none"> 1. Personnel will carefully fill tank from approved delivery source. 2. Fuel storage unit has already been tested and approved. 3. Personnel will refill fuel tank only when burner is shut down (no hot refueling). 4. Burner test will be conducted to ensure fuel lines do not leak and the burner system works as intended. <p>CORRECTIVE ACTIONS/EMERGENCY PROCEDURES:</p> <ol style="list-style-type: none"> 1. Begin emergency shutdown procedures. 2. Attempt to extinguish fire with ABC fire extinguishers if safe, otherwise call fire department and evacuate personnel. 2. If a mishap occurs appropriate procedures as outlined in safety plan will be initiated. 3. If serious injuries have occurred, call 911 and perform necessary first aid (if safe) until EMS arrives. 4. File a mishap report. <p>RISK ASSESSMENT MATRIX VALUE:</p> <p>Control measures of excluding non-essential personnel in the area to reduce risk to observers. Trained personnel are aware of equipment operation and hazard areas, and will be wearing pertinent personal protective equipment. Hazard severity is Critical due to potential for hospitalization. Hazard probability is Improbable: Risk assessment matrix value of II/E 15 (LOW risk)</p>			
THA ACCEPTED: YES	SRB CHAIRMAN: Perry Mitchell	SIGNATURE:	DATE:

AFRL FORM 12 Sep 00
Prescribing Directive: AFRLI 99-103

TEST HAZARD ANALYSIS (THA)		PAGE 1 of 1	
PROGRAM TITLE: Transportable Waste to Energy		TEST PLAN # 01-TWES	
PROGRAM MANAGER: Lt Thomas Bowen	PHONE NUMBER: 3-3725	HAZARD CATEGORY: Marginal LOW	DATE: 9 Nov 2011
PREPARED BY: Lt Thomas Bowen	PHONE NUMBER 3-3725	OFFICE SYMBOL: AFRL/RXQES	
<p>TEST HAZARD: Hazard #5 –Weather</p> <p>CAUSE: 1. Weather Related</p> <p>EFFECT: 1. Injury 2. Equipment or property damage</p> <p>CONTROLS/MINIMIZING PROCEDURES 1. Remain diligent and aware of surrounding weather patterns.</p> <p>CORRECTIVE ACTIONS/EMERGENCY PROCEDURES: 1. If severe weather approaches (lightening or strong wind storm within 10 miles), begin emergency shutdown and evacuate personnel to nearest building until storm passes. 2. If a mishap occurs, appropriate procedures as outlined in safety plan will be initiated. 3. If serious injuries have occurred, call 911 and perform necessary first aid (if safe) until EMS arrives. 4. File a mishap report.</p> <p>RISK ASSESSMENT MATRIX VALUE: Control measures of excluding non-essential personnel in the area to reduce risk to observers. Trained personnel are aware of equipment operation and hazard areas, and will be wearing pertinent personal protective equipment. Hazard severity is Marginal. Hazard probability is Remote: Risk assessment matrix value of III/D 14 (LOW risk)</p>			
THA ACCEPTED: YES	SRB CHAIRMAN: Perry Mitchell	SIGNATURE:	DATE:

Attachment 3: Emergency Telephone Number Reference List

Make this available to all Operators and visitors attending an experiment/test.

Emergency Telephone Number Reference List <i>Local to Tyndall AFB, FL</i>	
Responder	Number <i>(area code 850)</i>
Security Forces (TAFB “police”)	283-2254 or 911
Fire – to report	911
Base Phone Operator	283-1113
TAFB Environmental Management, Miguel Plaza	283-2398
TAFB Environmental assistant, Cintron, Jose	238-4341
AFRL Project Officer, Lt Thomas Bowen	283-3725; cell: 719-447-5788
AFRL Test Director, Randy Brockman	283-2784
Poison Control	800-222-1222
Gulf Coast Medical Center 449 W. 23 rd St, Panama City, FL	769-8341 or 747-7900
Bay Medical Center (closer to TAFB) 615 N. Bonita Ave, Panama City, FL	769-1511

Instructions for placing local phone calls at Tyndall AFB

- Pick-up a phone. If you receive a dial tone, follow the instruction in the next bullets. Otherwise, start by pressing one of the buttons with multiple numbers written on it to get an active phone line with a dial tone.
- Local calls beyond Tyndall AFB required “99” before the 7-digit phone number.
- Emergency calls can be made by dialing “911” with no additional prefix. (This has not been tested, but is believed to be true. If it fails, hang-up, and try again using “99 911”.)
- Tyndall AFB phone numbers are dialed with 7 digits, but no additional prefix.

Attachment 5: Material Safety Data Sheets (MSDS)

The MSDS listed in this attachment are described materials similar to those that may be use in during the experiments, but the manufacture/source and exact composition may vary. Table A5 states the purpose of the materials. For construction materials, refer to the MSDS binder kept in the TWES tool storage work area in building 9738.

Table A5: MSDS List for This Series of Tests

Substance	Purpose for TWES
Diesel Fuel	pre-heater fuel

Material Safety Data Sheet

SECTION 1 PRODUCT AND COMPANY IDENTIFICATION

DIESEL FUEL No. 2

Product Use: Fuel

Product Number(s): CPS203410 [See Section 16 for Additional Product Numbers]

Synonyms: 15 S Diesel Fuel 2, Alternative Low Aromatic Diesel (ALAD), Calco LS Diesel 2, Calco ULS DF2, Calco ULS Diesel 2, Chevron LS Diesel 2, Chevron ULS Diesel 2, Diesel Fuel Oil, Diesel Grade No. 2, Diesel No. 2-D S15, Diesel No. 2-D S500, Diesel No. 2-D S5000, Distillates, straight run, Gas Oil, HS Diesel 2, HS Heating Fuel 2, Light Diesel Oil Grade No. 2-D, LS Diesel 2, LS Heating Fuel 2, Marine Diesel, RR Diesel Fuel, Texaco Diesel, Texaco Diesel No. 2, Ultra Low Sulfur Diesel 2

Company Identification

Chevron Products Company
Marketing, MSDS Coordinator
6001 Bollinger Canyon Road
San Ramon, CA 94583
United States of America

Transportation Emergency Response

CHEMTREC: (800) 424-9300 or (703) 527-3887

Health Emergency

Chevron Emergency Information Center: Located in the USA. International collect calls accepted. (800) 231-0623 or (510) 231-0623

Product Information

MSDS Requests: (800) 689-3998
Technical Information: (510) 242-5357

SPECIAL NOTES: This MSDS covers all Chevron and Calco non-CARB Diesel No. 2 Fuels. The sulfur content is less than 0.5% (mass). Red dye is added to non-taxable fuel. (MSDS 6894)

SECTION 2 COMPOSITION/ INFORMATION ON INGREDIENTS

COMPONENTS	CAS NUMBER	AMOUNT
Diesel Fuel No. 2	68476-34-6	100 % wt/wt
Distillates, hydrodesulfurized, middle	64742-80-9	0 - 100 % wt/wt
Distillates, straight run middle (gas oil, light)	64741-44-2	0 - 100 % wt/wt
Kerosene	8008-20-6	0 - 25 % wt/wt
Kerosene, hydrodesulfurized	64742-81-0	0 - 25 % wt/wt
Distillates (petroleum), light catalytic cracked	64741-59-9	0 - 50 % wt/wt
Naphthalene	91-20-3	0.02 - 0.2 % wt/wt
Total sulfur	None	0 - 0.5 % wt/wt

Information on ingredients that are considered Controlled Products and/or that appear on the WHMIS Ingredient

Disclosure List (IDL) is provided as required by the Canadian Hazardous Products Act (HPA, Sections 13 and 14). Ingredients considered hazardous under the OSHA Hazard Communication Standard, 29 CFR 1910.1200, are also listed. See Section 15 for additional regulatory information.

SECTION 3 HAZARDS IDENTIFICATION

EMERGENCY OVERVIEW

- COMBUSTIBLE LIQUID AND VAPOR
- HARMFUL OR FATAL IF SWALLOWED - MAY CAUSE LUNG DAMAGE IF SWALLOWED
- CAUSES SKIN IRRITATION
- MAY CAUSE CANCER BASED ON ANIMAL DATA
- TOXIC TO AQUATIC ORGANISMS

IMMEDIATE HEALTH EFFECTS

Eye: Not expected to cause prolonged or significant eye irritation.

Skin: Contact with the skin causes irritation. Skin contact may cause drying or defatting of the skin. Symptoms may include pain, itching, discoloration, swelling, and blistering. Contact with the skin is not expected to cause an allergic skin response. Not expected to be harmful to internal organs if absorbed through the skin.

Ingestion: Because of its low viscosity, this material can directly enter the lungs, if swallowed, or if subsequently vomited. Once in the lungs it is very difficult to remove and can cause severe injury or death. May be irritating to mouth, throat, and stomach. Symptoms may include pain, nausea, vomiting, and diarrhea.

Inhalation: Mists of this material may cause respiratory irritation. Symptoms of respiratory irritation may include coughing and difficulty breathing. Breathing this material at concentrations above the recommended exposure limits may cause central nervous system effects. Central nervous system effects may include headache, dizziness, nausea, vomiting, weakness, loss of coordination, blurred vision, drowsiness, confusion, or disorientation. At extreme exposures, central nervous system effects may include respiratory depression, tremors or convulsions, loss of consciousness, coma or death.

DELAYED OR OTHER HEALTH EFFECTS:

Cancer: Prolonged or repeated exposure to this material may cause cancer. Whole diesel engine exhaust has been classified as a Group 2A carcinogen (probably carcinogenic to humans) by the International Agency for Research on Cancer (IARC). Diesel exhaust particulate has been classified as reasonably anticipated to be a human carcinogen in the National Toxicology Program's Ninth Report on Carcinogens. The National Institute of Occupational Safety and Health (NIOSH) has recommended that whole diesel exhaust be regarded as potentially causing cancer. Diesel engine exhaust is known to the State of California to cause cancer. Contains naphthalene, which has been classified as a Group 2B carcinogen (possibly carcinogenic to humans) by the International Agency for Research on Cancer (IARC).

See Section 11 for additional information. Risk depends on duration and level of exposure.

SECTION 4 FIRST AID MEASURES

Eye: No specific first aid measures are required. As a precaution, remove contact lenses, if worn, and flush eyes with water.

Skin: Wash skin with water immediately and remove contaminated clothing and shoes. Get medical attention if any symptoms develop. To remove the material from skin, use soap and water. Discard contaminated clothing and shoes

or thoroughly clean before reuse.

Ingestion: If swallowed, get immediate medical attention. Do not induce vomiting. Never give anything by mouth to an unconscious person.

Inhalation: Move the exposed person to fresh air. If not breathing, give artificial respiration. If breathing is difficult, give oxygen. Get medical attention if breathing difficulties continue.

Note to Physicians: Ingestion of this product or subsequent vomiting may result in aspiration of light hydrocarbon liquid, which may cause pneumonitis.

SECTION 5 FIRE FIGHTING MEASURES

See Section 7 for proper handling and storage.

FLAMMABLE PROPERTIES:

Flashpoint: (Pensky-Martens Closed Cup) 52 °C (125 °F) (Min)

Autoignition: 257 °C (494 °F)

Flammability (Explosive) Limits (% by volume in air): Lower: 0.6 Upper: 4.7

EXTINGUISHING MEDIA: Use water fog, foam, dry chemical or carbon dioxide (CO₂) to extinguish flames.

PROTECTION OF FIRE FIGHTERS:

Fire Fighting Instructions: For fires involving this material, do not enter any enclosed or confined fire space without proper protective equipment, including self-contained breathing apparatus.

Combustion Products: Highly dependent on combustion conditions. A complex mixture of airborne solids, liquids, and gases including carbon monoxide, carbon dioxide, and unidentified organic compounds will be evolved when this material undergoes combustion.

SECTION 6 ACCIDENTAL RELEASE MEASURES

Protective Measures: Eliminate all sources of ignition in the vicinity of the spill or released vapor. If this material is released into the work area, evacuate the area immediately. Monitor area with combustible gas indicator.

Spill Management: Stop the source of the release if you can do it without risk. Contain release to prevent further contamination of soil, surface water or groundwater. Clean up spill as soon as possible, observing precautions in Exposure Controls/Personal Protection. Use appropriate techniques such as applying non-combustible absorbent materials or pumping. All equipment used when handling the product must be grounded. A vapor suppressing foam may be used to reduce vapors. Use clean non-sparking tools to collect absorbed material. Where feasible and appropriate, remove contaminated soil. Place contaminated materials in disposable containers and dispose of in a manner consistent with applicable regulations.

Reporting: Report spills to local authorities as appropriate or required.

SECTION 7 HANDLING AND STORAGE

Precautionary Measures: Liquid evaporates and forms vapor (fumes) which can catch fire and burn with explosive force. Invisible vapor spreads easily and can be set on fire by many sources such as pilot lights, welding equipment, and electrical motors and switches. Fire hazard is greater as liquid temperature rises above 29C (85F).

Do not get in eyes, on skin, or on clothing. Do not taste or swallow. Do not breathe vapor or fumes. Do not breathe mist. Wash thoroughly after handling. Keep out of the reach of children.

Unusual Handling Hazards: WARNING! Do not use as portable heater or appliance fuel. Toxic fumes may accumulate and cause death.

General Handling Information: Avoid contaminating soil or releasing this material into sewage and drainage systems and bodies of water.

Static Hazard: Electrostatic charge may accumulate and create a hazardous condition when handling this material. To minimize this hazard, bonding and grounding may be necessary but may not, by themselves, be sufficient. Review all operations which have the potential of generating and accumulating an electrostatic charge and/or a flammable atmosphere (including tank and container filling, splash filling, tank cleaning, sampling, gauging, switch loading, filtering, mixing, agitation, and vacuum truck operations) and use appropriate mitigating procedures. For more information, refer to OSHA Standard 29 CFR 1910.106, 'Flammable and Combustible Liquids', National Fire

Protection Association (NFPA 77, 'Recommended Practice on Static Electricity', and/or the American Petroleum Institute (API) Recommended Practice 2003, 'Protection Against Ignitions Arising Out of Static, Lightning, and Stray Currents'.

General Storage Information: DO NOT USE OR STORE near heat, sparks, flames, or hot surfaces . USE AND STORE ONLY IN WELL VENTILATED AREA. Keep container closed when not in use.

Container Warnings: Container is not designed to contain pressure. Do not use pressure to empty container or it may rupture with explosive force. Empty containers retain product residue (solid, liquid, and/or vapor) and can be dangerous. Do not pressurize, cut, weld, braze, solder, drill, grind, or expose such containers to heat, flame, sparks, static electricity, or other sources of ignition. They may explode and cause injury or death. Empty containers should be completely drained, properly closed, and promptly returned to a drum reconditioner or disposed of properly.

SECTION 8 EXPOSURE CONTROLS/PERSONAL PROTECTION

GENERAL CONSIDERATIONS:

Consider the potential hazards of this material (see Section 3), applicable exposure limits, job activities, and other substances in the work place when designing engineering controls and selecting personal protective equipment. If engineering controls or work practices are not adequate to prevent exposure to harmful levels of this material, the personal protective equipment listed below is recommended. The user should read and understand all instructions and limitations supplied with the equipment since protection is usually provided for a limited time or under certain circumstances.

ENGINEERING CONTROLS:

Use process enclosures, local exhaust ventilation, or other engineering controls to control airborne levels below the recommended exposure limits.

PERSONAL PROTECTIVE EQUIPMENT

Eye/Face Protection: No special eye protection is normally required. Where splashing is possible, wear safety glasses with side shields as a good safety practice.

Skin Protection: Wear protective clothing to prevent skin contact. Selection of protective clothing may include gloves, apron, boots, and complete facial protection depending on operations conducted. Suggested materials for protective gloves include: Chlorinated Polyethylene (or Chlorosulfonated Polyethylene), Nitrile Rubber, Polyurethane, Viton.

Respiratory Protection: Determine if airborne concentrations are below the recommended occupational exposure limits for jurisdiction of use. If airborne concentrations are above the acceptable limits, wear an approved respirator that provides adequate protection from this material, such as: Air-Purifying Respirator for Organic Vapors.

When used as a fuel, this material can produce carbon monoxide in the exhaust. Determine if airborne concentrations are below the occupational exposure limit for carbon monoxide. If not, wear an approved positive-pressure air-supplying respirator.

Use a positive pressure air-supplying respirator in circumstances where air-purifying respirators may not provide adequate protection.

Occupational Exposure Limits:

Component	Country/ Agency	TWA	STEL	Ceiling	Notation
Diesel Fuel No. 2	ACGIH	100 mg/m3	--	--	Skin A3 total hydrocarbon
Diesel Fuel No. 2	CVX	--	1000 mg/m3	--	--
Kerosene	ACGIH	200 mg/m3	--	--	Skin A3 Total hydrocarbon vapor
Kerosene	CVX	--	1000 mg/m3	--	--
Kerosene, hydrodesulfurized	ACGIH	200 mg/m3	--	--	Skin A3 Total hydrocarbon vapor
Kerosene, hydrodesulfurized	CVX	--	1000 mg/m3	--	--
Naphthalene	ACGIH	10 ppm	15 ppm	--	Skin

		(weight)	(weight)		
--	--	----------	----------	--	--

NOTE ON OCCUPATIONAL EXPOSURE LIMITS: Consult local authorities for acceptable provincial values in Canada. Consult the Canadian Standards Association Standard 94.4-2002 Selection, Use and Care of Respirators.

SECTION 9 PHYSICAL AND CHEMICAL PROPERTIES

Attention: the data below are typical values and do not constitute a specification.

- Color:** Varies depending on specification
- Physical State:** Liquid
- Odor:** Petroleum odor
- pH:** Not Applicable
- Vapor Pressure:** 0.04 kPa (Approximate) @ 40 °C (104 °F)
- Vapor Density (Air = 1):** >1
- Boiling Point:** 175.6°C (348°F) - 370°C (698°F)
- Solubility:** Soluble in hydrocarbons; insoluble in water
- Freezing Point:** Not Applicable
- Melting Point:** Not Applicable
- Specific Gravity:** 0.8 - 0.88 @ 15.6°C (60.1°F) (Typical)
- Viscosity:** 1.9 cSt - 4.1 cSt @ 40°C (104°F)
- Odor Threshold:** No Data Available
- Coefficient of Water/Oil Distribution:** No Data Available

SECTION 10 STABILITY AND REACTIVITY

- Chemical Stability:** This material is considered stable under normal ambient and anticipated storage and handling conditions of temperature and pressure.
- Incompatibility With Other Materials:** May react with strong acids or strong oxidizing agents, such as chlorates, nitrates, peroxides, etc.
- Hazardous Decomposition Products:** None known (None expected)
- Hazardous Polymerization:** Hazardous polymerization will not occur.
- Sensitivity to Mechanical Impact:** No.

SECTION 11 TOXICOLOGICAL INFORMATION

IMMEDIATE HEALTH EFFECTS

- Eye Irritation:** The eye irritation hazard is based on evaluation of data for similar materials or product components.
- Skin Irritation:** The skin irritation hazard is based on evaluation of data for similar materials or product components.
- Skin Sensitization:** This material did not cause skin sensitization reactions in a Buehler guinea pig test.
- Acute Dermal Toxicity:** LD50: >5ml/kg (rabbit).
- Acute Oral Toxicity:** LD50: > 5 ml/kg (rat)
- Acute Inhalation Toxicity:** 4 hour(s) LC50: > 5mg/l (rat). For additional information on the acute toxicity of the components, call the technical information center.

ADDITIONAL TOXICOLOGY INFORMATION:

This product contains gas oils.
 CONCAWE (product dossier 95/107) has summarized current health, safety and environmental data available for a number of gas oils, typically hydrodesulfurized middle distillates, CAS 64742-80-9, straight-run middle distillates, CAS 64741-44-2, and/or light cat-cracked distillate CAS 64741-59-9. **CARCINOGENICITY:** All materials tested have caused the development of skin tumors in mice, but all featured severe skin irritation and sometimes a long latency period before tumors developed. Straight-run and cracked gas oil samples were studied to determine the influence of dermal irritation on the carcinogenic activity of middle distillates. At non-irritant doses the straight-run

gas oil was not carcinogenic, but at irritant doses, weak activity was demonstrated. Cracked gas oils, when diluted with mineral oil, demonstrated carcinogenic activity irrespective of the occurrence of skin irritation. Gas oils were tested on male mice to study tumor initiating/promoting activity. The results demonstrated that while a straight-run gas oil sample was neither an initiator or promotor, a blend of straight-run and FCC stock was both a tumor initiator and a promoter.

GENOTOXICITY: Hydrotreated & hydrodesulfurized gas oils range in activity from inactive to weakly positive in in-vitro bacterial mutagenicity assays. Mouse lymphoma assays on straight-run gas oils without subsequent hydrodesulphurization gave positive results in the presence of S9 metabolic activation. In-vivo bone marrow cytogenetics and sister chromatic exchange assay exhibited no activity for straight-run components with or without hydrodesulphurization. Thermally or catalytically cracked gas oils tested with in-vitro bacterial mutagenicity assays in the presence of S9 metabolic activation were shown to be mutagenic. In-vitro sister chromatic exchange assays on cracked gas oil gave equivocal results both with and without S9 metabolic activation. In-vivo bone marrow cytogenetics assay was inactive for two cracked gas oil samples. Three hydrocracked gas oils were tested with in-vitro bacterial mutagenicity assays with S9, and one of the three gave positive results. Twelve distillate fuel samples were tested with in-vitro bacterial mutagenicity assays & with S9 metabolic activation and showed negative to weakly positive results. In one series, activity was shown to be related to the PCA content of samples tested. Two in-vivo studies were also conducted. A mouse dominant lethal assay was negative for a sample of diesel fuel. In the other study, 9 samples of No 2 heating oil containing 50% cracked stocks caused a slight increase in the number of chromosomal aberrations in bone marrow cytogenetics assays. **DEVELOPMENTAL TOXICITY:** Diesel fuel vapor did not cause fetotoxic or teratogenic effects when pregnant rats were exposed on days 6-15 of pregnancy. Gas oils were applied to the skin of pregnant rats daily on days 0-19 of gestation. All but one (coker light gas oil) caused fetotoxicity (increased resorptions, reduced litter weight, reduced litter size) at dose levels that were also maternally toxic.

This product contains naphthalene. **GENERAL TOXICITY:** Exposure to naphthalene has been reported to cause methemoglobinemia and/or hemolytic anemia, especially in humans deficient in the enzyme glucose-6-phosphate dehydrogenase. Laboratory animals given repeated oral doses of naphthalene have developed cataracts.

REPRODUCTIVE TOXICITY AND BIRTH DEFECTS: Naphthalene did not cause birth defects when administered orally to rabbits, rats, and mice during pregnancy, but slightly reduced litter size in mice at dose levels that were lethal to the pregnant females. Naphthalene has been reported to cross the human placenta. **GENETIC TOXICITY:** Naphthalene caused chromosome aberrations and sister chromatid exchanges in Chinese hamster ovary cells, but was not a mutagen in several other in-vitro tests. **CARCINOGENICITY:** In a study conducted by the National Toxicology Program (NTP), mice exposed to 10 or 30 ppm of naphthalene by inhalation daily for two years had chronic inflammation of the nose and lungs and increased incidences of metaplasia in those tissues. The incidence of benign lung tumors (alveolar/bronchiolar adenomas) was significantly increased in the high-dose female group but not in the male groups. In another two-year inhalation study conducted by NTP, exposure of rats to 10, 30, and 60 ppm naphthalene caused increases in the incidences of a variety of nonneoplastic lesions in the nose. Increases in nasal tumors were seen in both sexes, including olfactory neuroblastomas in females at 60 ppm and adenomas of the respiratory epithelium in males at all exposure levels. The relevance of these effects to humans has not been established. No carcinogenic effect was reported in a 2-year feeding study in rats receiving naphthalene at 41 mg/kg/day.

This product may contain significant amounts of Polynuclear Aromatic Hydrocarbons (PAH's) which have been shown to cause skin cancer after prolonged and frequent contact with the skin of test animals. Brief or intermittent skin contact with this product is not expected to have serious effects if it is washed from the skin. While skin cancer is unlikely to occur in human beings following use of this product, skin contact and breathing, of mists, vapors or dusts should be reduced to a minimum.

SECTION 12 ECOLOGICAL INFORMATION

ECOTOXICITY

96 hour(s) LC50: 21-210 mg/l (*Salmo gairdneri*)

48 hour(s) EC50: 20-210 mg/l (*Daphnia magna*)

72 hour(s) EC50: 2.6-25 mg/l (Raphidocellus subcapitata)
This material is expected to be toxic to aquatic organisms.

ENVIRONMENTAL FATE

On release to the environment the lighter components of diesel fuel will generally evaporate but depending on local environmental conditions (temperature, wind, mixing or wave action, soil type, etc.) the remainder may become dispersed in the water column or absorbed to soil or sediment. Diesel fuel would not be expected to be readily biodegradable. In a modified Strum test (OECD method 301B) approximately 40% biodegradation was recorded over 28 days. However, it has been shown that most hydrocarbon components of diesel fuel are degraded in soil in the presence of oxygen. Under anaerobic conditions, such as in anoxic sediments, rates of biodegradation are negligible.

SECTION 13 DISPOSAL CONSIDERATIONS

Use material for its intended purpose or recycle if possible. This material, if it must be discarded, may meet the criteria of a hazardous waste as defined by USEPA under RCRA (40CFR261), Environment Canada, or other State, Provincial, and local regulations. Measurement of certain physical properties and analysis for regulated components may be necessary to make a correct determination. If this material is classified as a hazardous waste, federal law requires disposal at a licensed hazardous waste disposal facility.

SECTION 14 TRANSPORT INFORMATION

The description shown may not apply to all shipping situations. Consult 49CFR, or appropriate Dangerous Goods Regulations, for additional description requirements (e.g., technical name) and mode-specific or quantity-specific shipping requirements.

TC Shipping Description: UN1202, GAS OIL, 3, III

IMO/IMDG Shipping Description: UN1202, GAS OIL, 3, III, FLASH POINT SEE SECTION 5

ICAO/IATA Shipping Description: UN1202, GAS OIL, 3, III

DOT Shipping Description: GAS OIL, COMBUSTIBLE LIQUID, UN1202,III

SECTION 15 REGULATORY INFORMATION

REGULATORY LISTS SEARCHED:

01-1=IARC Group 1
01-2A=IARC Group 2A
01-2B=IARC Group 2B
35=WHMIS IDL

The following components of this material are found on the regulatory lists indicated.

Naphthalene 01-2B, 35

CHEMICAL INVENTORIES:

All components comply with the following chemical inventory requirements: AICS (Australia), DSL (Canada), EINECS (European Union), IECSC (China), KECI (Korea), PICCS (Philippines), TSCA (United States).

WHMIS CLASSIFICATION:

Class B, Division 3: Combustible Liquids

Class D, Division 2, Subdivision A: Very Toxic Material -
Carcinogenicity

Class D, Division 2, Subdivision B: Toxic Material -

Skin or Eye Irritation. This product has been classified in accordance with the hazard criteria of the Controlled Products Regulations and the MSDS contains all of the information required by those regulations. (See Hazardous

Products Act (HPA), R.S.C. 1985, c.H-3,s.2).

MSDS PREPARATION:

This Material Safety Data Sheet has been prepared by the Toxicology and Health Risk Assessment Unit, ERTC, P.O. Box 1627, Richmond, CA 94804, (888)676-6183.

Revision Date: July 31, 2006

SECTION 16 OTHER INFORMATION

Additional Product Number(s): CPS203413, CPS203417, CPS220122, CPS225114, CPS225115, CPS225150, CPS266176, CPS270000, CPS270005, CPS270094, CPS270095, CPS270096, CPS271006, CPS272006, CPS272007, CPS272008, CPS272009, CPS272010, CPS272011, CPS272012, CPS272013, CPS272093, CPS272102, CPS272126, CPS272152, CPS272185, CPS272190, CPS272195, CPS272593, CPS272601, CPS272693, CPS272793, CPS273003, CPS273030, CPS273053, CPS275000

REVISION STATEMENT: This revision updates the following sections of this Material Safety Data Sheet: 1,16.

ABBREVIATIONS THAT MAY HAVE BEEN USED IN THIS DOCUMENT:

TLV - Threshold Limit Value	TWA - Time Weighted Average
STEL - Short-term Exposure Limit	PEL - Permissible Exposure Limit
	CAS - Chemical Abstract Service Number
ACGIH - American Conference of Government Industrial Hygienists	IMO/IMDG - International Maritime Dangerous Goods Code
API - American Petroleum Institute	MSDS - Material Safety Data Sheet
CVX - Chevron	NFPA - National Fire Protection Association (USA)
DOT - Department of Transportation (USA)	NTP - National Toxicology Program (USA)
IARC - International Agency for Research on Cancer	OSHA - Occupational Safety and Health Administration

APPENDIX B: TEST LOG SHEET

Hurst Boiler Steam Generation Test		
Date	6-Dec-11	
Time		
<u>Diesel Burner</u>		
Diesel Fuel Tank Level		
Diesel Fuel Flow		
Burner head position setting	3	
Burner air damper settings		
Low fire cam (blue)	25	
High fire cam (red)	50	
Transition cam (orange)	38	
High or Low Fire		
Flue Gas Temperature in Furnace (deg C)		
Infrared Thermometer Reading		
Flue Gas Temperature in Boiler Exhaust Stack (deg C)		
Infrared Thermometer Reading		
-		
<u>Feedwater Tank</u>		
Water meter reading x100		
x10		
x1		
x0.1		
Composite water meter reading		
Ultrasonic Flow Meter Verification		
Feedwater Tank (% of sight glass)		
Feedwater Tank Temperature (deg C)		
Pump 1 (Manual/Off/Automatic)		
Pump 1 Discharge Pressure (psig)		
Pump 2 (Manual/Off/Automatic)		
Pump 2 Discharge Pressure (psig)		
<u>Steam</u>		

Hurst Boiler Level (% of sight glass)		
Boiler feed water temperature @ gate valve C13 w/infrared (deg C)		
Steam temperature @ flowmeter w/infrared (deg C)		
Steam flowrate		
Steam pressure @ pressure gauge upstream of PRV-1 (psig)		
Steam pressure @ pressure gauge downstream of PRV-1 (psig)		
Valve S18 on low pressure steam line (open/closed)		
<u>Condensate Recycle</u>		
Condensate Receiver Pump (On/off)		
Condensate Recycle Temperature w/infrared		

LIST OF SYMBOLS, ABBREVIATIONS, AND ACRONYMS

ANTARES	Antares Group, Inc.
AFB	Air Force Base
AFRL	Air Force Research Laboratory
bhp	boiler horse power
Btu	British thermal unit
CAD	computer-aided design
ft	foot; feet
gal	gallon(s)
gph	gallons per hour
gpm	gallons per minute
HHV	higher heating value
hp	horse power
HPS	high pressure steam
hr	hour
HRSG	heat recovery steam generator
kW	kilowatt
kWh	kilowatt-hours (= 1,000 Watt-hours)
lb	pound(s)
lb/hr	pounds per hour
LPS	low pressure steam
mA	milliamp (1/1000th of an Ampere)
min	minute(s)
MPS	medium pressure steam
P&ID	process and instrumentation diagram
PLC	programmable logic controller
PRV	pressure reducing valve
psia	pounds per square inch, absolute
psig	pounds per square inch, gauge
s	second(s)
TWES	Transportable Waste to Energy System