



# DEFENSE TECHNICAL INFORMATION CENTER

*Information for the Defense Community*

DTIC<sup>®</sup> has determined on 8 / 1 / 12 that this Technical Document has the Distribution Statement checked below. The current distribution for this document can be found in the DTIC<sup>®</sup> Technical Report Database.

**DISTRIBUTION STATEMENT A.** Approved for public release; distribution is unlimited.

**© COPYRIGHTED.** U.S. Government or Federal Rights License. All other rights and uses except those permitted by copyright law are reserved by the copyright owner.

**DISTRIBUTION STATEMENT B.** Distribution authorized to U.S. Government agencies only (fill in reason) (date of determination). Other requests for this document shall be referred to (insert controlling DoD office).

**DISTRIBUTION STATEMENT C.** Distribution authorized to U.S. Government Agencies and their contractors (fill in reason) (date determination). Other requests for this document shall be referred to (insert controlling DoD office).

**DISTRIBUTION STATEMENT D.** Distribution authorized to the Department of Defense and U.S. DoD contractors only (fill in reason) (date of determination). Other requests shall be referred to (insert controlling DoD office).

**DISTRIBUTION STATEMENT E.** Distribution authorized to DoD Components only (fill in reason) (date of determination). Other requests shall be referred to (insert controlling DoD office).

**DISTRIBUTION STATEMENT F.** Further dissemination only as directed by (insert controlling DoD office) (date of determination) or higher DoD authority.

*Distribution Statement F is also used when a document does not contain a distribution statement and no distribution statement can be determined.*

**DISTRIBUTION STATEMENT X.** Distribution authorized to U.S. Government Agencies and private individuals or enterprises eligible to obtain export-controlled technical data in accordance with DoDD 5230.25; (date of determination). DoD Controlling Office is (insert controlling DoD office).

# SPARNET YEAR 1 FINAL REPORT

Contract No. W911QY-11-C-0012

## Integrated Short Range, Low Bandwidth, Wearable Communications Networking Technologies

Principal Investigator: *Drew Barnett*

Date of Publication: Monday, 30 April, 2012

Contracting Officer's Representative: *Mr. William Tharion*



ELINTRIX  
4901 Morena Boulevard  
Suite 204  
San Diego, CA 92117-3373  
(858) 483-1399

20120703298

## Table of Contents

Introduction .....	7
Research Discussions.....	7
1 Specifications.....	8
2 SAN Radio.....	9
2.1 R.F. Design Improvements.....	9
2.1.1 LNA Enhancement.....	9
2.1.2 Improvements to Variable Attenuator.....	9
2.1.3 Increase Drive to Power Amplifier .....	11
2.1.4 Modification of Filter to 25kHz Bandwidth .....	12
2.1.5 Optimization of Power Amplifier Matching .....	12
2.1.6 Layout Improvements .....	13
2.1.7 Fabrication, Assembly and Debugging .....	25
2.1.8 Performance Characterization and Verification Testing .....	26
2.2 Digital Design Improvements.....	26
2.2.1 Improve Processor Access to Memory Resources .....	26
2.2.2 Digital Automatic Gain Control .....	27
2.2.3 Verification of Circuitry for Voice- and Text-applications .....	27
2.3 SDR Algorithm Improvements .....	29
2.3.1 Transmit Chain.....	30
2.3.2 Demodulator Carrier-Tracking.....	30
2.3.3 Received Signal-strength Indicator (RSSI) .....	30
2.3.4 Improved Computational Efficiency .....	30
2.3.5 Digital Automatic Gain Control Algorithm.....	31
2.4 Software Improvements.....	31
2.4.1 Power Management .....	31
2.4.2 Enhanced Support for Field Testing.....	32
2.4.3 Liquid-crystal-display (LCD) Integration .....	33
2.4.4 911 Messaging .....	34
2.4.5 GPS 1 Pulse-Per-Second (PPS) Interrupt Callback.....	36
2.4.6 Data Packet Payload Length .....	36
2.4.7 Flash Storage and Download .....	37
3 Bluetooth Option Card Development.....	45
3.1 Development of Bluetooth Board.....	45
3.2 Sensor Collaborators .....	46
3.2.1 Zephyr Protocol.....	46
3.2.2 POLAR Protocol.....	46
3.3 Bluetooth Software Development.....	47

For Official Use Only (FOUO)

3.4	Issues.....	47
4	Network Software R&D.....	47
4.1	Integration of GPS 1PPS in Network Time Keeping Operation.....	49
4.2	New Managed Network Architecture.....	50
4.2.1	New Network Creation Rules.....	51
4.3	Bi-directional Communication.....	52
4.4	Operation of Two Squads and Demonstration of Recovery of Off-net Student.....	52
4.5	Develop Performance-assessment Software.....	53
4.5.1	TOC Application/Data Broker Error Rate Calculations.....	54
4.6	Network Performance Estimates.....	56
4.7	Modification of SAN Network Software for Repeater-node Application.....	66
4.8	Store and Forward Capability.....	66
5	Application Research and Development.....	69
5.1	Icons Jumping in Map Application and GPS Acquisition Time.....	69
5.2	TOC Application/Data Broker.....	69
5.3	Improved Administration and Configuration Capabilities.....	70
5.3.1	TOC Application Main Display.....	71
5.3.2	Security Administration.....	75
5.3.3	Performance-assessment Capabilities.....	76
5.3.4	Sensor Information.....	78
5.3.5	Playback Capability.....	79
5.3.6	Log Utility Analyzer.....	79
5.4	Instructor Handheld Application.....	80
5.4.1	Purpose-built PDA Application for Bluetooth-enabled Sensor.....	82
5.4.2	Handheld Speech.....	82
6	Analysis and Reporting of Network Performance.....	82
6.1	Interpreting the Analyses.....	83
6.1.1	Message Throughput Rate.....	84
6.2	Demonstration 1 Results.....	85
6.2.1	Packet Errors.....	85
6.2.2	Packet-detection Issue.....	85
6.2.3	Network Registration.....	86
6.2.4	Measurements.....	86
6.3	Demonstration 2 and Demonstration 3 Field and Laboratory Results.....	86
6.3.1	System Reliability during Demonstration 2 and Demonstration 3.....	87
6.3.2	Demonstration 2 Results.....	89
6.3.3	Demonstration 3 Results.....	92
6.4	December Demonstration.....	95
6.5	Demonstration 4 Results.....	96
6.5.1	Issues Observed in Demonstration 4.....	97
6.5.2	Update Rate Calculations of 30-second Period vs. 1-minute Period.....	98

## For Official Use Only (FOUO)

6.5.3	Star Topology (Body-Worn Antenna) Demonstration Results .....	98
6.5.4	Star Topology (Rubber-ducky Antenna) Demonstration Results.....	101
6.5.5	Supplementary Range Demonstration.....	102
6.5.6	Linear Topology (Rubber-ducky Antenna) Demonstration Results .....	106
6.5.7	Bi-directional Messaging Separation-case and New Features Advancement.....	108
6.5.8	Overall Packet-Error-Rate (PER) and Message Throughput Rate for Full Duration of Demonstration 4.....	112
7	KEY RESEARCH ACCOMPLISHMENTS .....	113
8	CONCLUSION .....	115

### Tables

Table 1.	Squad-subscription completion-frame (star-topology, 10 trainees)	62
Table 2.	Squad-subscription completion-frame (linear-topology, ascending slot-times)	62
Table 3.	Squad-subscription completion-frame (linear-topology, descending slot-times)	62
Table 4.	Squad-subscription completion-frame (star-topology, five trainees)	63
Table 5.	Estimated Effect on Network Throughput by Additional Repeater in Linear Repeater Topology	63
Table 6.	Packet Error and Message Rate – Linear Topology, Demonstration 2	89
Table 7.	Recovered Store-and-Forward Packet Transmissions from Table 6, Linear Topology, Demonstration 2	90
Table 8.	Overall calculation of error rates for full duration of Demonstration 2	91
Table 9.	Recovered Data Packets	91
Table 10.	Packet Error and Message Rate – Linear Topology, Demonstration 3	93
Table 11.	Packet Error and Message Rate for 30-minute, 2-node, Store-and-Forward	95
Table 12.	Packet Error and Message Rate - Star Topology, Body-Worn Antenna, 30-second period	100
Table 13.	Packet Error and Message Rate - Star Topology, Body-Worn Antenna, 1-minute period	100
Table 14.	Packet Error and Message Rate - Star Topology, Rubber-ducky Antenna, 30-second period	101
Table 15.	Packet Error and Message Rate - Star Topology, Rubber-ducky Antenna, 1-minute period	101
Table 16.	Packet Error and Message Rate – Range Demonstration, 30-second period	103
Table 17.	Packet Error and Message Rate – Range Demonstration, 1-minute period	103
Table 18.	Packet Error and Message Rate – Range Demonstration, 5-minute Data Collection, 30-second period	105
Table 19.	Packet Error and Message Rate – Range Demonstration, 5-min. Data Collection, 1-minute period	105
Table 20.	Packet Error and Message Rate – Linear Topology, 30-second period	107
Table 21.	Packet Error and Message Rate – Linear Topology, 1-minute period	107
Table 22.	Overall calculation of error rates for full duration of Demonstration 4, 30-second period	112
Table 23.	Overall calculation of error rates for full duration of demonstration, 1-minute period	113

## Figures

Figure 1. PIN diode frequency response/attenuation vs. current drive (mA)	10
Figure 2. Receiver chain	10
Figure 3. Continuation of receiver circuitry	11
Figure 4. Initial simulation of PA pre-distortion	13
Figure 5. R.F. switches and pre-selector filter schematic	14
Figure 6. Plot illustrating the difference in response between the standard BPF topology and the one used in the design without the layout	14
Figure 7. Simulated response of the 1 <sup>st</sup> iteration of the pre-selector filter alone, without the layout	15
Figure 8. Monte Carlo response of Figure 7	16
Figure 9. Worse case response at 225MHz and 380MHz are:~ -4.1dB and -2.6dB respectively	16
Figure 10. Schematic components change of caps and resistor values	17
Figure 11. Layout, including the vias	17
Figure 12. The new response with and without the layout	18
Figure 13. The new response with and without the layout	19
Figure 14. Monte Carlo response with markers indicating narrowest predicted response	19
Figure 15. LNA schematic	20
Figure 16. Plot of LNA performance	20
Figure 17. Plot of LNA performance with layout	21
Figure 18. Result of the simulations compared to the results without the layout effects	21
Figure 19. Input IP3 and input 1dB compression point vs. frequency response	22
Figure 20. Schematic of BPF	22
Figure 21. Plot of tunable BPF response	23
Figure 22. Tune range, filter bandwidth and tune voltages of tunable BPF	24
Figure 23. Tune voltages	24
Figure 24. Tune range, filter bandwidth and tune voltages of tunable BPF, with layout	25
Figure 25. Tune voltages, with layout	25
Figure 26. Response of OP-AMP	28
Figure 27. Response of OP-AMP, continued	28
Figure 28. FIR version:	29
Figure 29. Notional SDR Code-module Relationships	30
Figure 30. Synthesized "Elintrix" logo on SAN radio LCD	33
Figure 31. Map Application Node Coloring Scheme	35
Figure 32. Alert Window Displayed via TOC application for Bi-directional 911 Messaging	35
Figure 33. Fully-assembled Bluetooth Option-card CCA with Break-off Bluetooth Module	45
Figure 34. TOC application main screen display	54
Figure 35. Star-topology with 10 trainee-nodes	59
Figure 36. Linear-topology with 5 trainee-nodes	59
Figure 37. Slot-ordering supporting shortest configuration-time	60
Figure 38. Slot-ordering imposing longest configuration-time	61
Figure 39. Routed, un-routed and broadcast packet visualization	68
Figure 40. TOC Application Main Display	71
Figure 41. TOC User Login	75
Figure 42. Security administration window	76
Figure 43. Recall of old test data and associated packet error rate of individual nodes	77
Figure 44. Time series graph of test error rate statistics	77
Figure 45. Time series graphs – save and print options	78

## For Official Use Only (FOUO)

Figure 46. Heart rate plots for individual nodes	79
Figure 47. TOC playback user interface	79
Figure 48. Instructor's map application main screen display (Tablet)	81
Figure 49. Roster screen shot of instructor's mapping device	81
Figure 50. Illustration of Linear, 5-Hop Topology Demonstration	92
Figure 51. Illustration of Linear, 5-Hop Topology Demonstration	93
Figure 52. Illustration of Range Test, between Instructor and student node	96
Figure 53. Illustrations of Star Topology (Body-worn Antenna) Demonstration	99
Figure 54. Illustrations of Star Topology (Rubber-duck Antenna) Demonstration	102
Figure 55. Illustration of Range Demonstration, 706 Meters	104
Figure 56. Illustration of Range Demonstration, 930 Meters	106
Figure 57. Illustration of Linear, 5-Hop Topology Demonstration	108
Figure 58. Illustration of 2 instructor-led training squads	109
Figure 59. Illustration of node 6's migration towards squad #1, and subsequent off-network event	110
Figure 60. Illustration of node 6's registration with squad #1 instructor	111

## Introduction

This report provides a summary of research and development (R&D) activity and accomplishments, with respect to the development of SPARNET, for U.S. Army contract number W911QY-11-C-0012 – Integrated Short Range, Low Bandwidth, Wearable Communications Networking Technologies.

The research and development (R&D) efforts conducted in this project were aimed at the implementation of an integrated short-range, low-bandwidth, wearable communications, sensing, and networking, based on software-defined-radio (SDR) technology. The operating-objective of the system is to enable the remote monitoring, analysis and display of summary activity, physiologic, and geo-location data from free-roaming dismounted Warfighters in a variety of austere military training settings. Work was executed to systematically advance the Technical Readiness Level (TRL) of the current technological elements and expedite the realization of a fully-founded SPARNET system. The purpose of the system is to provide a powerful means of protecting the health and well-being of Soldiers while they are engaged in physiologically-challenging training that is conducted in harsh environments.

The technological elements on which the work was based are purpose-built, from scratch, to directly address the goals and requirements for the Spartan Network (SPARNET), as described in the United States Army Research Institute of Environmental Medicine (USARIEM) Performance Work Statement (PWS) for SPARNET, dated 26 May 2010. The PWS sets forth specific demonstration and reporting requirements. This document reports the activities that were conducted in the field and in the laboratory, showing that the performance-objectives set forth in the PWS for SPARNET were achieved during the span of the base year contractual requirement.

## Research Discussions

By leveraging the significant investments already made by the Army in applicable, purpose-built, technological elements, the design of the resulting, integrated network was optimized to meet project objectives. Incremental advancement enables development of system-embodiments that can be more immediately-available for use in small-sized groups, while larger groups can be supported as the development progresses.

During the course of the project, R.F. circuit card assembly (CCA) engineering activity was accelerated and software modifications were implemented to address two, known bugs, as identified in the project proposal. One issue was related to node-registration in the network code and the other was related to software defined radio timing-recovery loop. Additionally, improvements to individual algorithms that support the SDR capability were made. Design and architectural approach for the performance assessment software to facilitate the capture and storage of performance metrics were expanded. Work was undertaken to reduce the processing time required by some algorithms and standard functions. The data payload was increased from 32-bytes to 64-bytes. Newly assembled R.F. circuit card assemblies (CCAs) hardware were paired and calibrated with existing digital boards.

The integration of liquid-crystal-displays (LCDs) into the squad-area radios, to enable display of radio- and user-specific parameters was executed. Bluetooth functionality was advanced, tested and integrated. Zephyr (Annapolis, MD) and POLAR (Lake Success, NY) heart-rate monitoring-capability are supported via a purpose-built Bluetooth CCA. In addition, the repeater backbone was completed, integrated and tested. A hybrid architecture of the automatic gain control (AGC) was designed to

provide faster convergence over a broad range of signal strength. The enhanced registration scheme was completed, integrated and tested. Optimizations of the network layer to advance the capabilities towards the tasks of Option years (1 and 2) were implemented. Bi-directional communication was attained as well as enhancements to the improvements to the TOC database/application and the instructor's map application.

Extensive testing was done to acquire field-test data and to validate the test plans for the executions of Demonstrations 1-4. Issues observed in the field during the performance of Demonstrations 1-4, were thoroughly investigated. Comprehensive testing of the system was performed to validate the resolutions of the issues. Increased levels of indoor and outdoor testing were conducted to support corrective and refinement work on software elements of SPARNET in preparation for the demonstrations. Through numerous executions, the team enhanced its ability to efficiently execute field-testing and demonstration scripts. Increased levels of indoor and outdoor testing were conducted to support corrective and refinement work on hardware and software elements of SPARNET. Details of these activities are reported, in the subsections that follow.

## 1 Specifications

The objective of this task area was to produce updated technical specifications, ensuring that all requirements (functional, regulatory and environmental) are reflected in suitable detail to provide for efficient use in the design and verification processes.

DD1494 activity was carried out at appropriate times during the project, when changes to the radiating characteristics of network-elements took place. This included changes in modulation type, transmission power-levels, antenna types and other relevant factors. We also worked with an officer from Center for Health Promotion and Preventive Medicine (CHPPM) (Aberdeen Proving Ground, MD) to acquire approval for use of rubber duck antennas, to file an updated Test Plan, and transference of approval of Test Plan to current contract, W911QY-11-C-0012, *Integrated Short Range, Low Bandwidth, Wearable Communications Networking Technologies*.

At the onset of the project, Elintrix and USARIEM collaborated to define the requirements that reflect selected standards and user needs/preferences. The Performance Work Statement (PWS) for U.S. Army contract number W911QY-11-C-0012 sets forth specific demonstration and reporting requirements. To better understand the specifications and ultimately meet these requirements, a kick-off meeting was conducted between Elintrix and USARIEM. USARIEM provided feedback to questions that were periodically submitted by Elintrix, throughout the duration of the project.

To clarify various aspects of the requirements set forth in the PWS, Elintrix and USARIEM held several telephone conferences to ensure that the test plan submitted to the USARIEM prior to the executions of the four required demonstrations accurately established the activities that that were to be conducted in the field and in the laboratory. These activities were to show that the performance objectives associated with the fulfillment of the four required demonstrations for the Spartan network (SPARNET), were achieved.

Updated specifications were written to ensure that all requirements were reflected in suitable detail to provide efficient use in the design and verification processes. The resulting specifications guided the engineering activities, ensuring that the specified functionality, configuration and performance levels were successfully addressed. As the incremental development progressed through each stage, other

specific requirements were expected to emerge. The emergence of such requirements was possible, in part, because the architecture of the Squad Area Network (SAN) portion of the overall system conveniently supports new, functional extensions and because the analyses of data collected from field operations was expected to reveal helpful, situation-specific refinements.

## **2 SAN Radio**

Work executed on the radio was done to bring the SDR CCAs and associated software to a level of maturity that was foundational for refinement to a cost-reduced platform, in Option Year 1. The work involved incorporation of candidate improvements that have been identified in the ongoing research and development (R&D). Additionally, improvements to individual algorithms that support the SDR capability were made. The SAN SDR was augmented with the addition of a Bluetooth-link capability. The Bluetooth-link was substituted for I-PAN functionality, as Bluetooth capability is required to connect with commercially-available, heart-rate monitors such as those produced by Zephyr and Polar. Design and implementation of performance-assessment software to facilitate the capture and storage of system metrics was executed. Work was undertaken to reduce the processing time required by some algorithms and standard functions.

### **2.1 R.F. Design Improvements**

The objective of this task was to execute perfective work that was aimed at optimizing the performance of various elements of the R.F. circuitry. The work involved incorporation of improvements that were identified in the ongoing research and development (R&D) of the R.F. CCAs. Exemplar achievements include:

- Improved isolation between digital board and transceiver, reducing conducted interference from the digital board
- Addition of a variable attenuator in the transmitter circuitry to provide for transmit power-control
- Extended baseband filter response to allow for higher symbol rates

#### **2.1.1 LNA Enhancement**

Through the addition of a software-adjustable, variable resistor, the 1dB compression was made controllable by the system processor. This modification allowed the low noise amplifier (LNA) to dynamically adapt to hostile R.F. environments.

#### **2.1.2 Improvements to Variable Attenuator**

A PIN diode attenuator in the architecture was designed and simulated for an approximate, maximum attenuation of 12 dB. Performance testing has shown that there was a need to decrease the insertion loss and extend the attenuation range. This allowed for a more balanced front-end gain, in conjunction with an internal limiter-circuit. These improvements to the design were executed under this task. A high linearity, R.F. Digital step attenuator covering a 31.5 dB attenuation range in 0.5 dB steps was integrated. The minimum predicted insertion loss is  $\sim 0.1$ dB with a maximum attenuation of  $\sim 11.5$ dB.

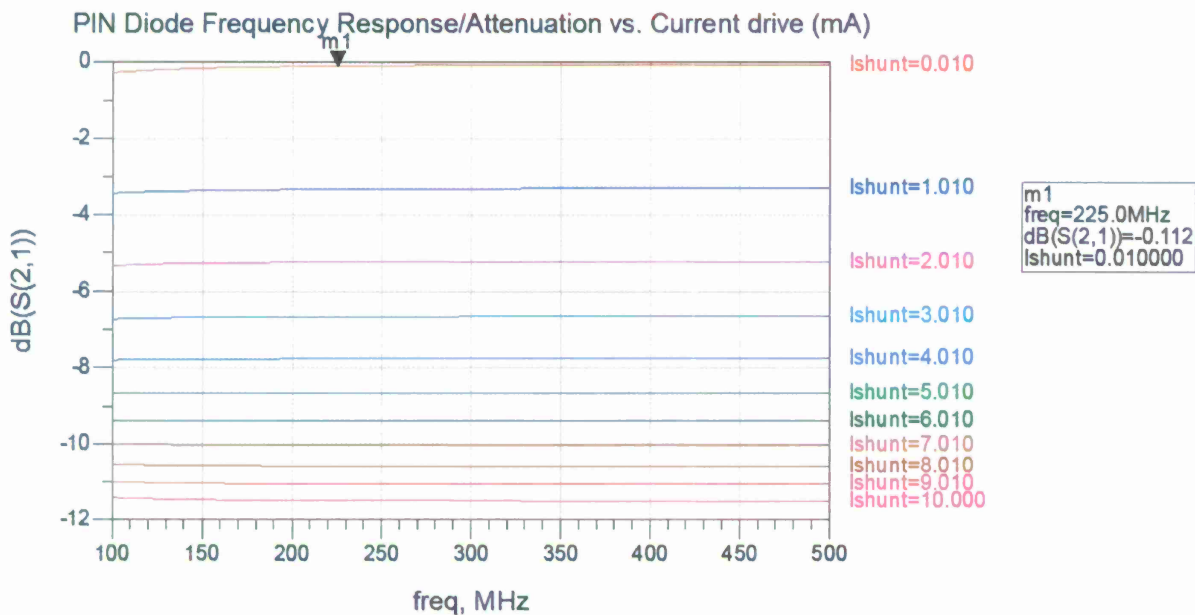

Figure 1. PIN diode frequency response/attenuation vs. current drive (mA)

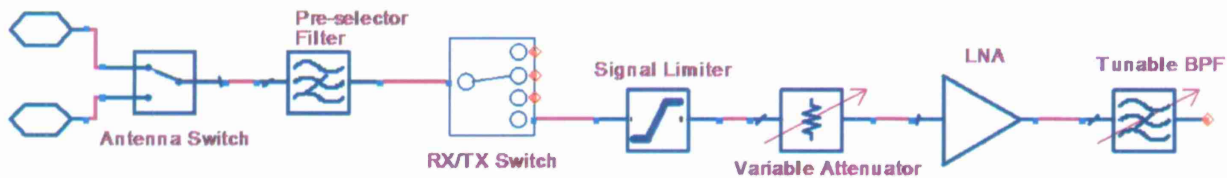

Figure 2. Receiver chain

The pre-selector filter rejects out-of-band signals. The receiver/transmitter switch routes the signals through the limiter and variable attenuator which combines to protect the LNA from high level in-band signals. The tunable band pass filter (BPF) then attenuates in-band signals.

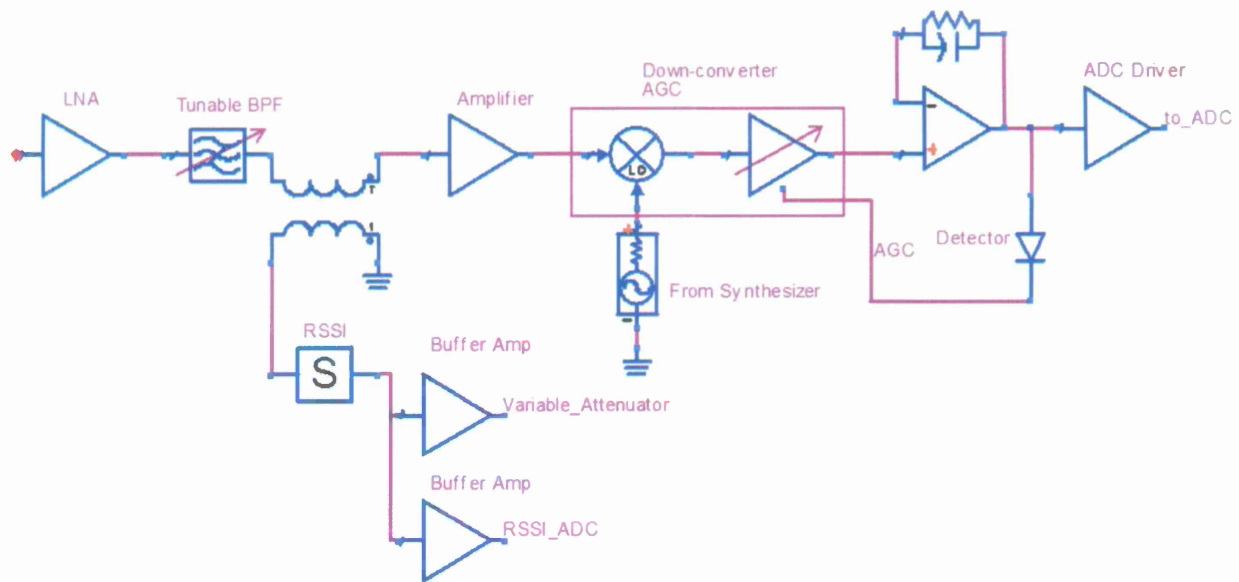

Figure 3. Continuation of receiver circuitry

The tunable BPF is followed by a 2<sup>nd</sup> LNA and tunable BPF. The signal is then sampled by the received signal strength indicator (RSSI) and the detected voltage is scaled and sent to the variable attenuator. In addition, the detected voltage is sent to the processor. This aids in detecting in-band interferers in scan mode. The radio can be powered down except for the front-end prior to the RSSI detector and the spectrum scanned for interference by using only the tunable filters. The RSSI also aids in determining which power amplifier (PA) to select by measuring the received signal strength and assuming reciprocity, determines if the low power PA can be used to save battery power.

### 2.1.3 Increase Drive to Power Amplifier

Performance and characterization tests have shown that a more efficient transmitter-chain design can be achieved by adding amplification to the output of the up-conversion mixer, thus boosting the drive to the power amplifiers. Under this task, amplification was incorporated and circuit-optimization was advanced to achieve higher efficiencies.

To boost the drive to the power amplifiers, a circuit driver to control the amplification output of the up-conversion mixer was executed. The switch to a lower power mixer, which required the addition of a low gain driver amplifier, resulted in a more efficient transmitter chain design. This was the trade-off between the added amplifier and the previous high power mixer. The added amplifier will allow for appropriate drive levels to be added to each PA – Low Band (high-power), High Band (high-power) and low-power. The Low Band and High Band designations refer to the frequency range. Low voltage PA's cannot maintain efficiency over a wide bandwidth, therefore to maintain output power with efficiency, two PA's covering the entire band are used.

Command line interface (CLI) modifications to provide the ability to change the attenuation level were successfully completed. Investigative effort supporting perfective work on the transmitter driver chain was concluded. An extensive characterization of the receiver and transmitter of the individual radios was performed. Tracking filters on the R.F. hardware were re-tuned for better efficiency. This enhancement increased radio sensitivity. Enhanced command line interface (CLI) to automatically

program the transmit scale factors when setting power amplifiers (PA) from low-power to high-power, eliminating the need for manual reprogramming was executed.

#### **2.1.4 Modification of Filter to 25kHz Bandwidth**

Simulations were performed to update values of the capacitors and resistors in the baseband filter to enable a 25kHz bandwidth. The modification of the filter resulted in reduced transit time and an increased symbol rate.

The symbol-rate and shape of the symbol determine the amount of frequency bandwidth that is occupied during a transmission. Increasing the symbol rate increases the width of the frequency band that it will occupy. The system is currently constrained to operate within a 25 kHz-wide band. Therefore, the theoretical maximum symbol rate is 25 k symbols/second. Due to practical considerations and limitations, the achievable symbol rate is significantly lower. We should expect to achieve a symbol rate that is somewhere in the vicinity of 0.66 to 0.8 of the theoretical maximum, resulting in a maximum data-rate of 30 kbps to 40 kbps. For purposes of discussion, assume a symbol-rate of 15 k symbols/second. This will provide a data-rate of 30 k symbols/second.

As an aside, the principal reason that 25 k symbols/second cannot be used is because it will result in too much energy being injected into adjacent bands. This is not permitted by the regulatory authorities. So, it is necessary to lower the symbol rate, so that the occupied bandwidth is reduced, along with the out-of-band energy.

In summary, the maximum symbol rate is limited by frequency-bandwidth considerations. Based on this limit and because there are two data-bits of information per symbol, the data-rate is limited. Collectively, this means that we don't have the option of simply increasing the symbol-rate to achieve a higher data-rate, unless we can obtain a wider frequency-band in which to operate, or we change to a different modulation type (which would introduce other detrimental effects). The bottom line is that, for now, we're likely to be limited to a data-rate around 30 kbps.

#### **2.1.5 Optimization of Power Amplifier Matching**

Work toward linearization of the high-power amplifiers was conducted. The work included: measurements and simulations to characterize the frequency response of the transmit chain, measurement of the compression points of the transmit driver amplifier, extraction of s-parameters and compression point data, development of a simulation-model of the PAs, and simulations of the PA layout to aid in refinement of impedance-matching were achieved during this period.

Below is the simulated result of the pre-distortion. It requires additional work to more satisfactorily achieve a flattened gain-response, across the band, and to increase the power added efficiency.

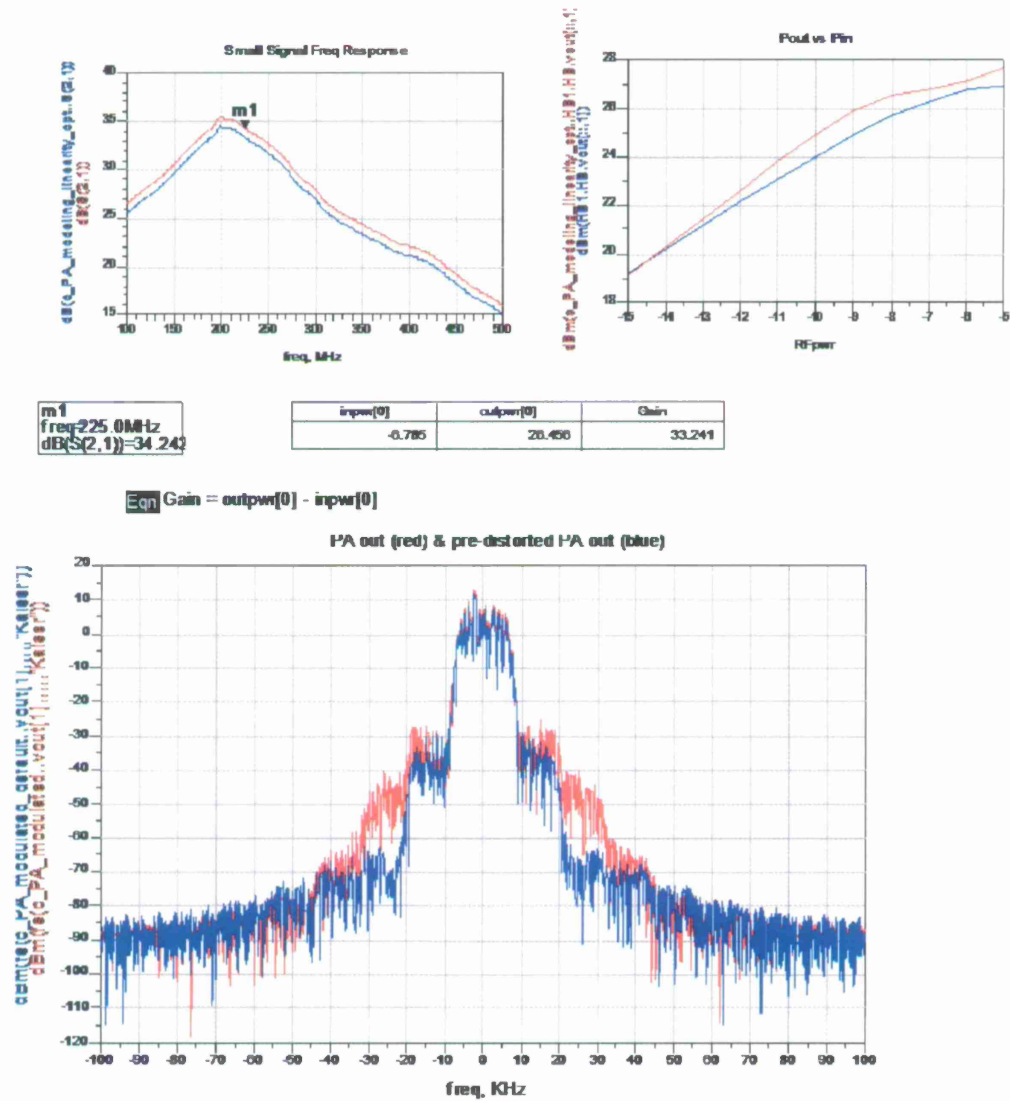

Figure 4. Initial simulation of PA pre-distortion

### 2.1.6 Layout Improvements

Improved tuning of the passband in the pre-selector was needed to reduce insertion loss. Simulations indicate that this can be accomplished through optimization of the layout. Improvements to the pre-selector were executed and refinements to the layout, to better tune passband, were advanced.

To assist in the design of the board layout, EM (electro-magnetic) simulation was used to predict the performance of the signals with the traces, trace to trace coupling, and circuits as a complete system. In other words, after the circuits were simulated and verified, they were then added to the layout and a final simulation of select circuits with the layout was performed. This type of simulation is particularly useful in predicting the shifts in the filters due to the layout.

The insertion loss is ~ 1.5dB higher than simulated in portions of the passband. This lowers the output power and raises the receiver noise figure.

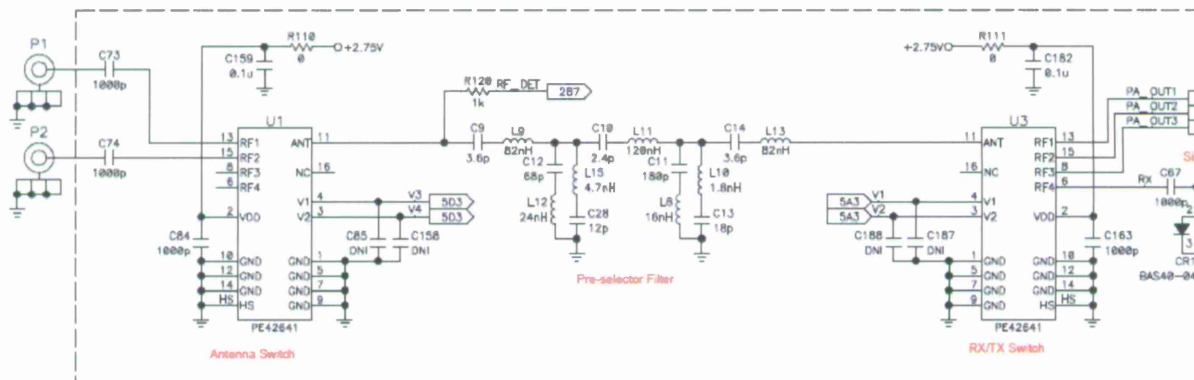

Figure 5. R.F. switches and pre-selector filter schematic

U1 is the SP4T switch that is used to route signals from the antenna to the pre-selector.

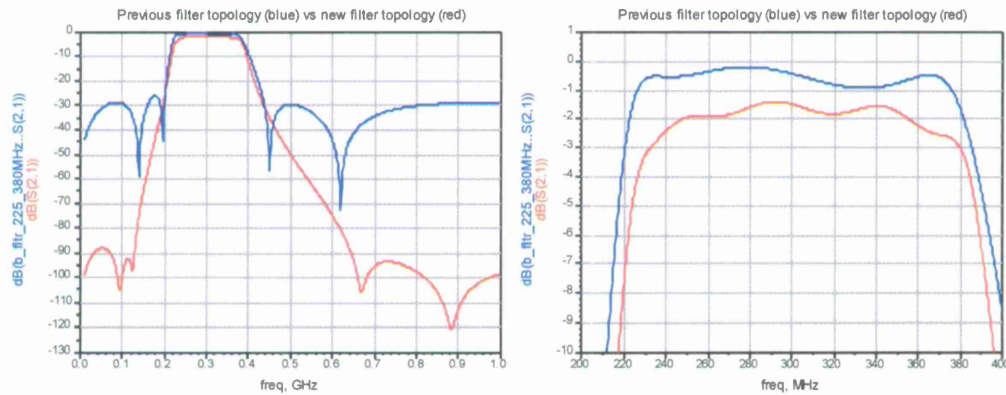

Figure 6. Plot illustrating the difference in response between the standard BPF topology and the one used in the design without the layout

The BPF corner frequencies are 225MHz to 380MHz. The response of the 1<sup>st</sup> iteration of the pre-selector filter alone without the layout was simulated as follows:

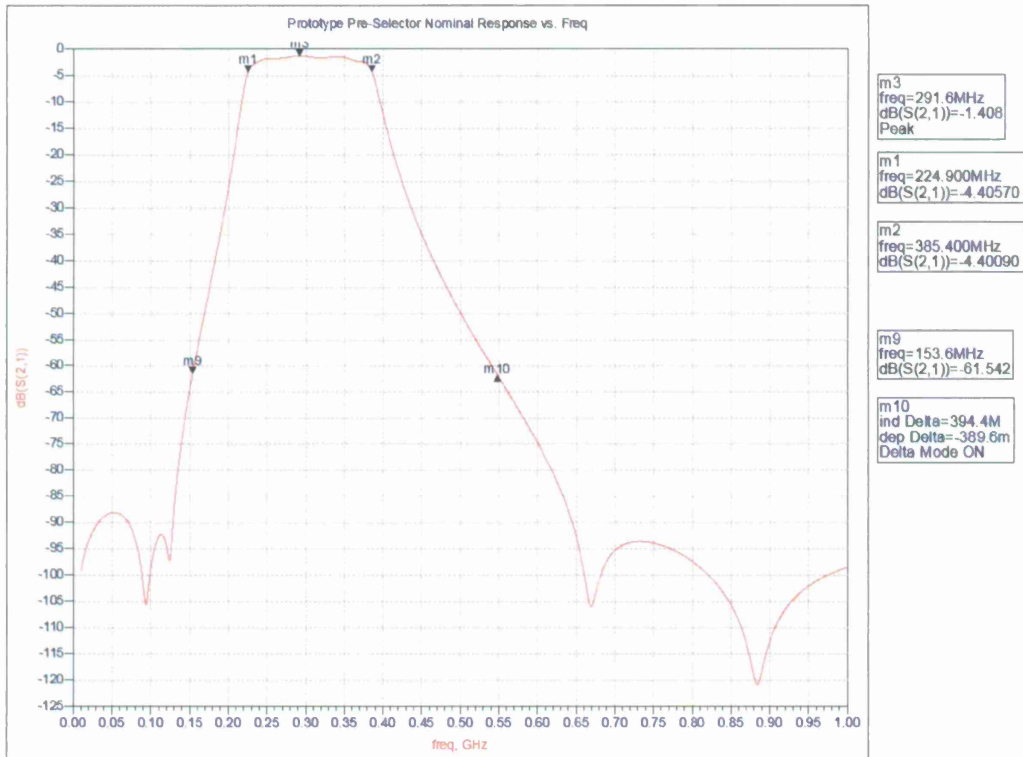

Figure 7. Simulated response of the 1<sup>st</sup> iteration of the pre-selector filter alone, without the layout

The 3dB bandwidth extends from 224.9MHz to 385.4MHz. The Monte Carlo response is as follows:



Figure 8. Monte Carlo response of Figure 7

The worst case 50dB pts are ~ 159MHz and 530MHz.

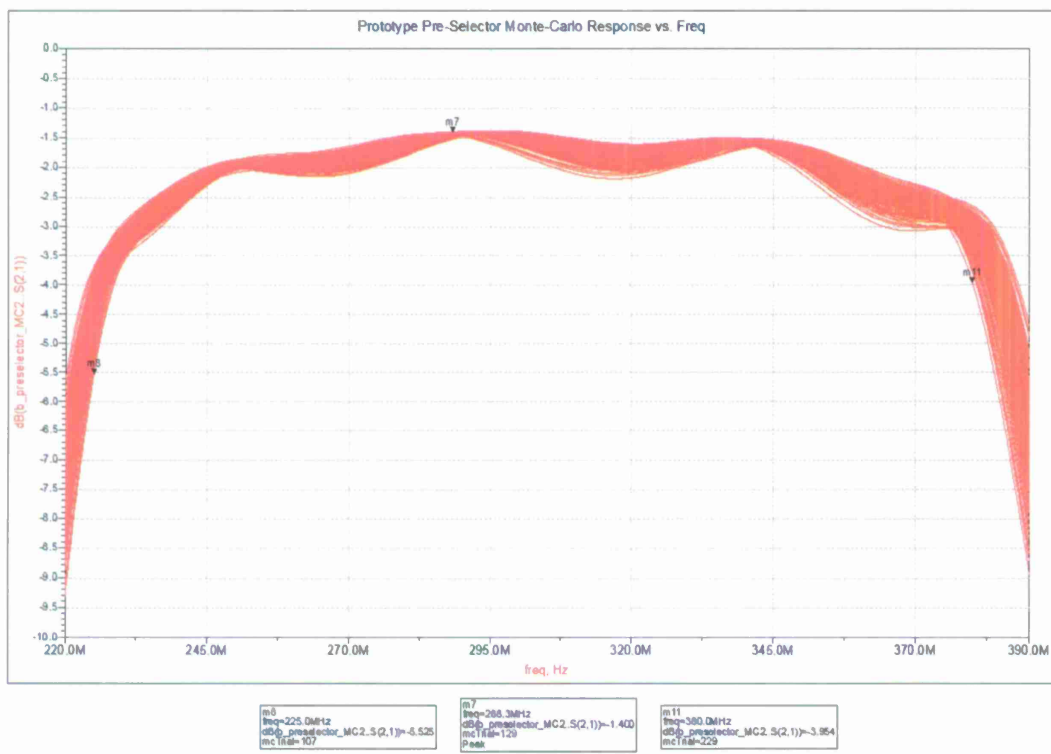

Figure 9. Worst case response at 225MHz and 380MHz are ~ -4.1dB and -2.6dB respectively

The layout was simulated and then the components were added. This resulted in a change in component values (2<sup>nd</sup> iteration) from the original design, as shown below:

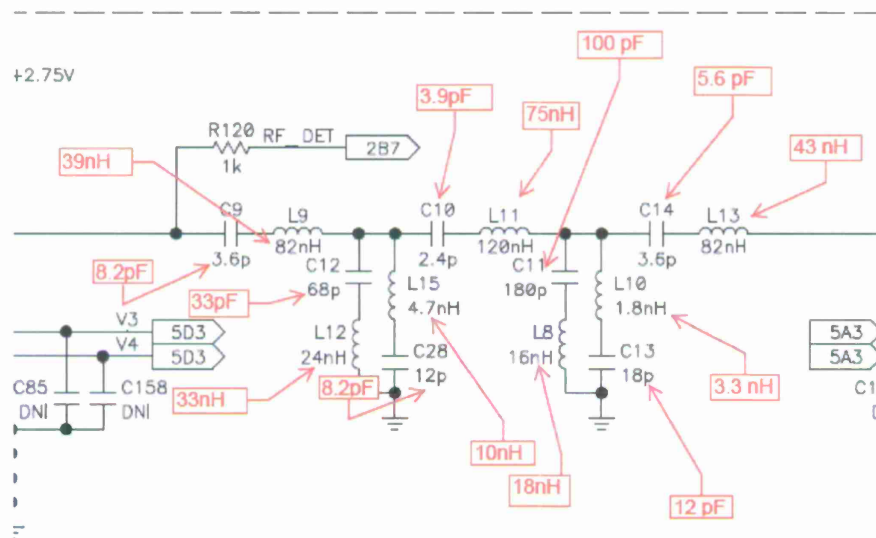

Figure 10. Schematic components change of caps and resistor values

The layout, including the vias that was simulated, looks like as follows:

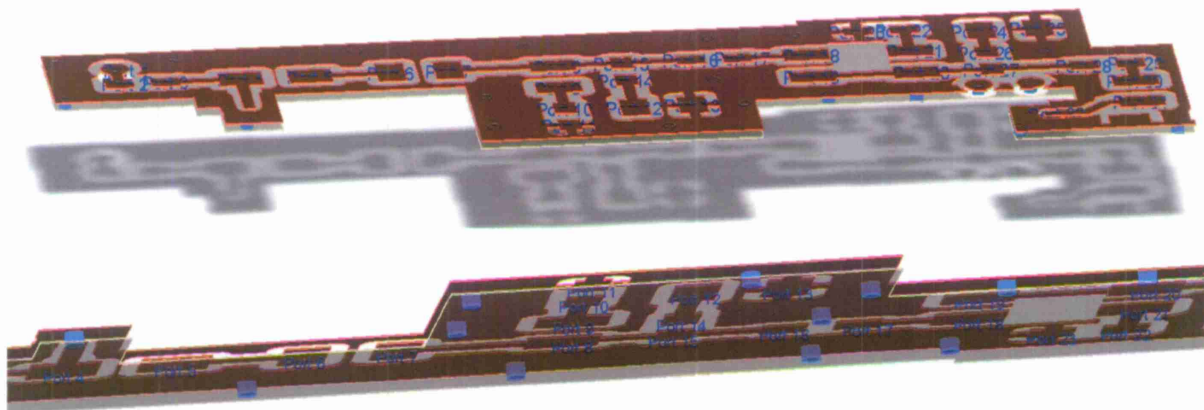

Figure 11. Layout, including the vias

The blue designators indicate the ports used to attach the lumped element components. The cylinders in the bottom diagram are the vias, attached to the 2<sup>nd</sup> layer ground plane.

The new response with and without the layout is as follows:

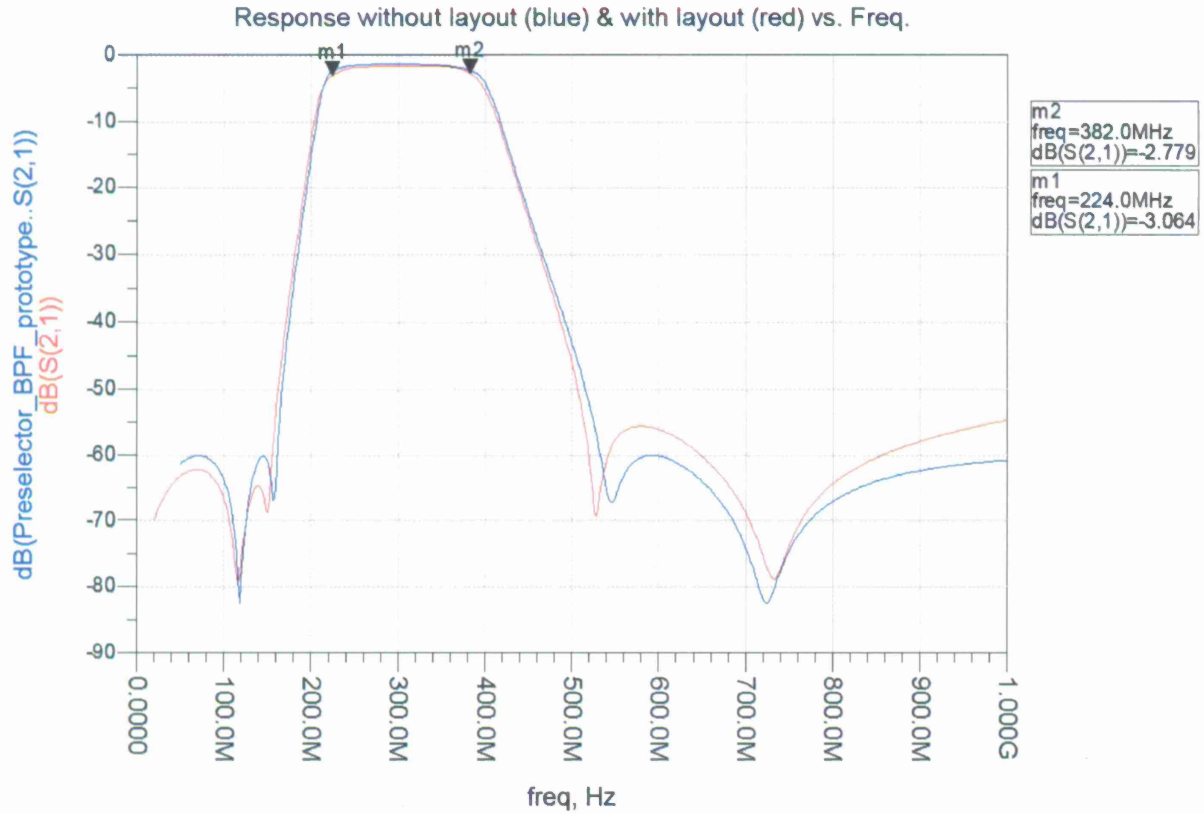

Figure 12. The new response with and without the layout

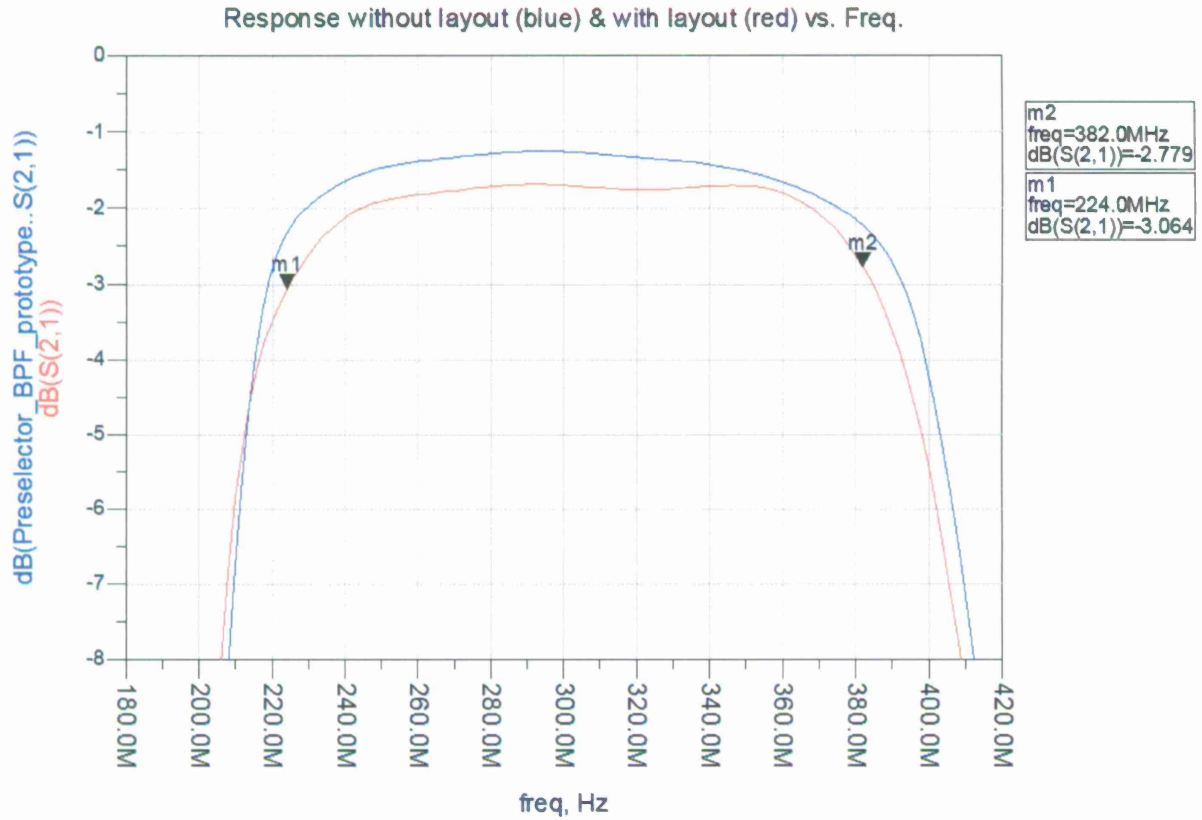

Figure 13. The new response with and without the layout

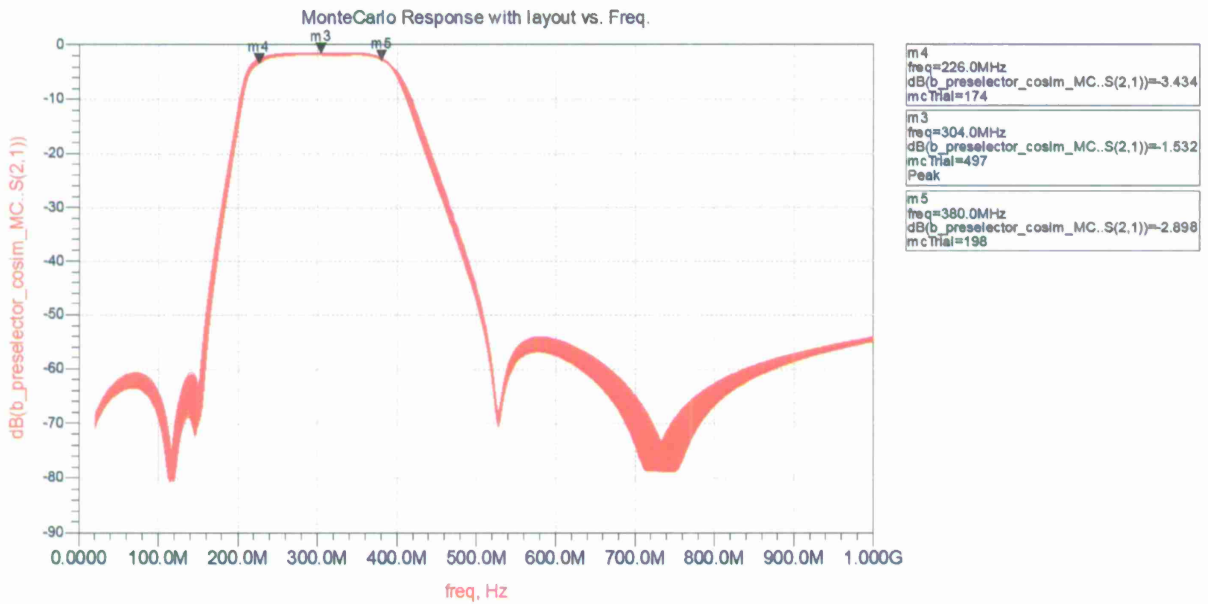

Figure 14. Monte Carlo response with markers indicating narrowest predicted response

From the attenuator the signal is amplified by the 1<sup>st</sup> LNA. This LNA has been designed for linearity as well as noise figure. The following plots indicate performance.

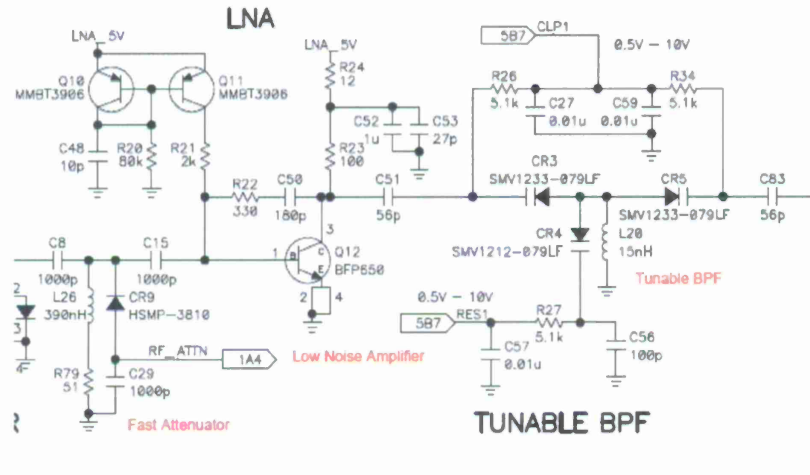

Figure 15. LNA schematic

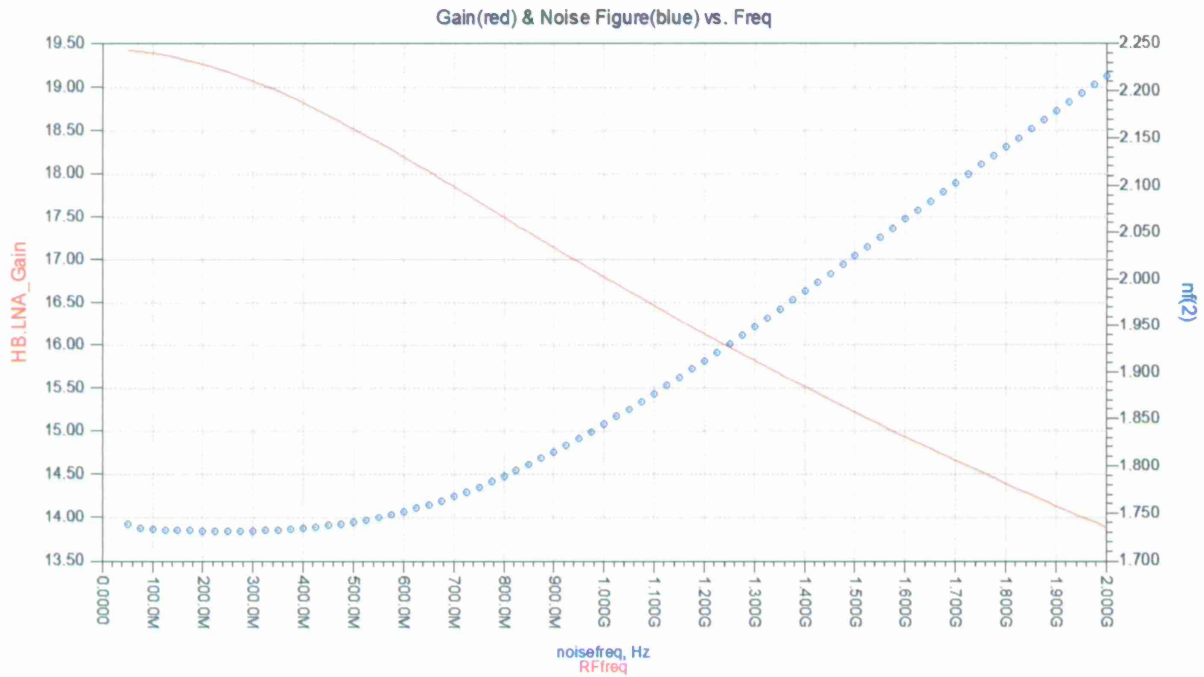

Figure 16. Plot of LNA performance

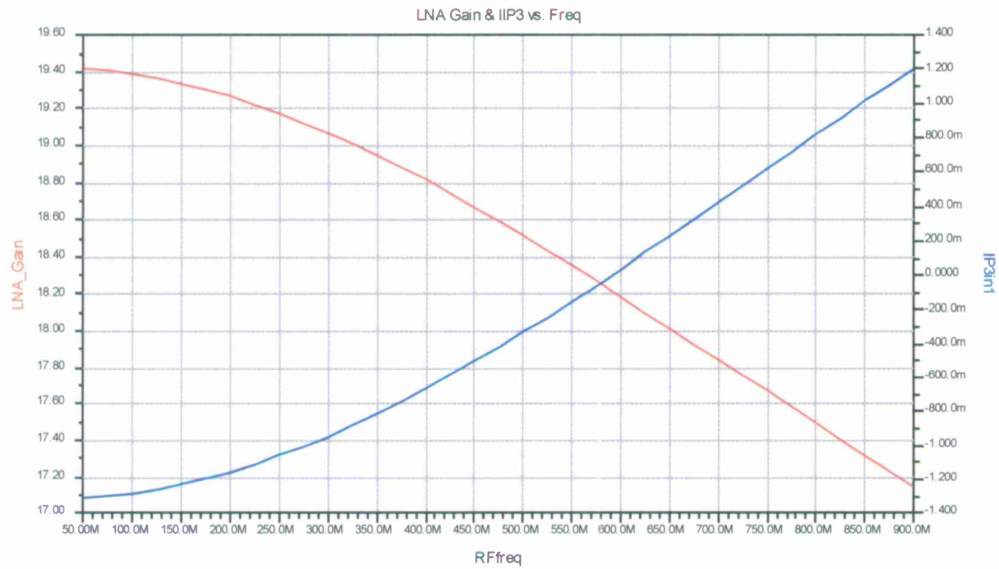

Figure 17. Plot of LNA performance with layout

Over the band of interest (225-380MHz) the noise figure is  $\sim 1.7$ dB. The gain simulates to  $\sim 19$ dB without the layout effects. The input 3<sup>rd</sup> order intercept is  $\sim -1$ dBm.

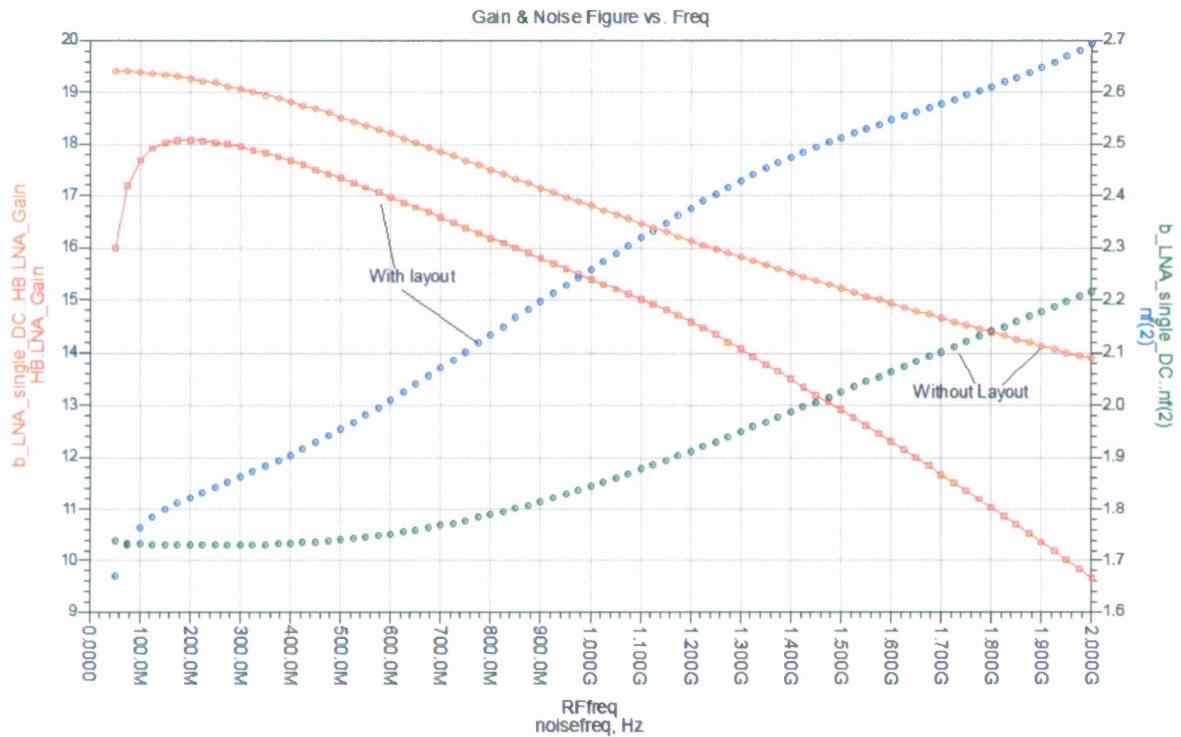

Figure 18. Result of the simulations compared to the results without the layout effects

As expected the gain with the layout effects included is ~ 1dB lower than without the layout effects. The noise figure diverges from the predicted plot without the layout as the loss in the traces increases with frequency.

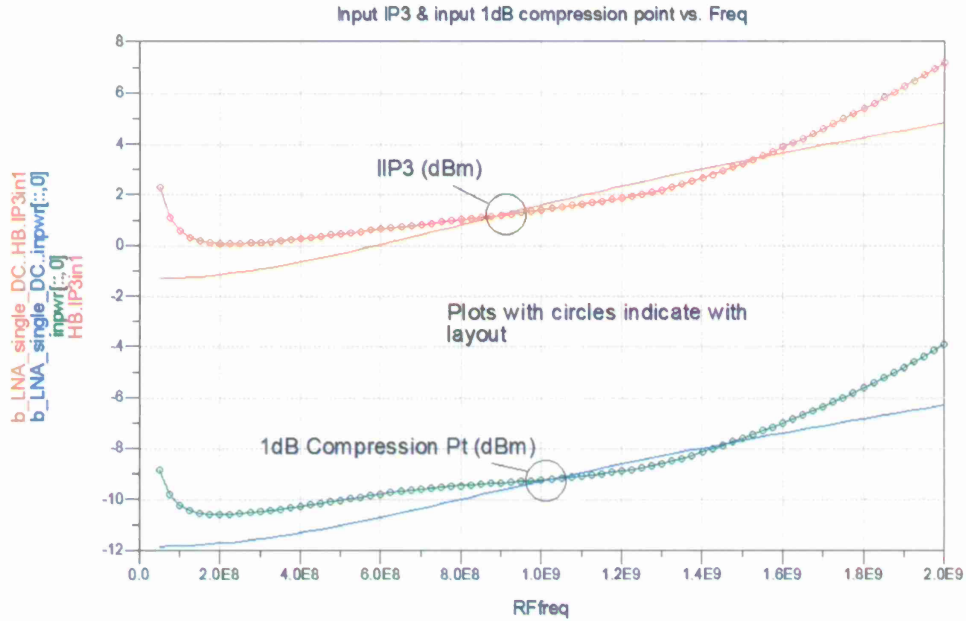

Figure 19. Input IP3 and input 1dB compression point vs. frequency response

The plots above that have circles on the data points indicate the response with the layout. The compression pt and IIP3 improvement at the lower frequencies is due to the lower gain. At the higher frequencies there is a mismatch at the harmonics which affects the linearity of the amplifier.

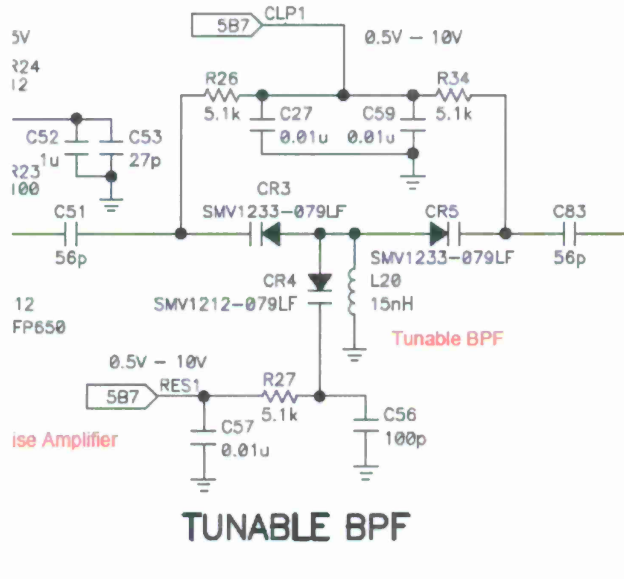
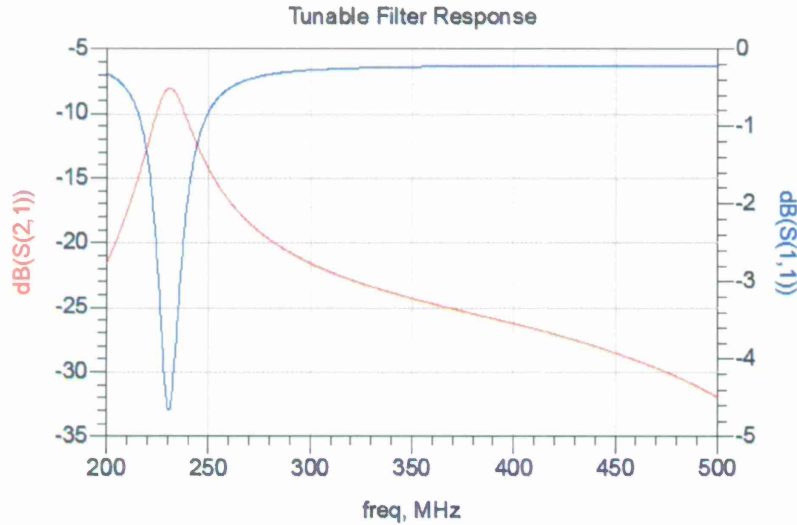

Figure 20. Schematic of BPF

## For Official Use Only (FOUO)

The tunable BPF can be tuned for bandwidth as well as center frequency. This allows for narrowing up the bandwidth in the case of a strong desired signal which provides for additional attenuation of the signal. It also gives additional in-band blocker rejection.



$$\text{Eqn } bw3dB = \text{bandwidth\_func}(\text{db}(S21), 3)$$

$$\text{Eqn } fc3 = \text{center\_freq}(\text{db}(S21), 3)$$

$$\text{Eqn } \text{Filter\_Q} = fc3/bw3dB$$

bw3dB	fc3	Filter_Q
18.12 M	231.5 M	12.77

**Figure 21. Plot of tunable BPF response**

Using an optimizer and sweeping the filter the following plots were generated. They indicate the tune range, filter BW, filter Q, and tune voltages.

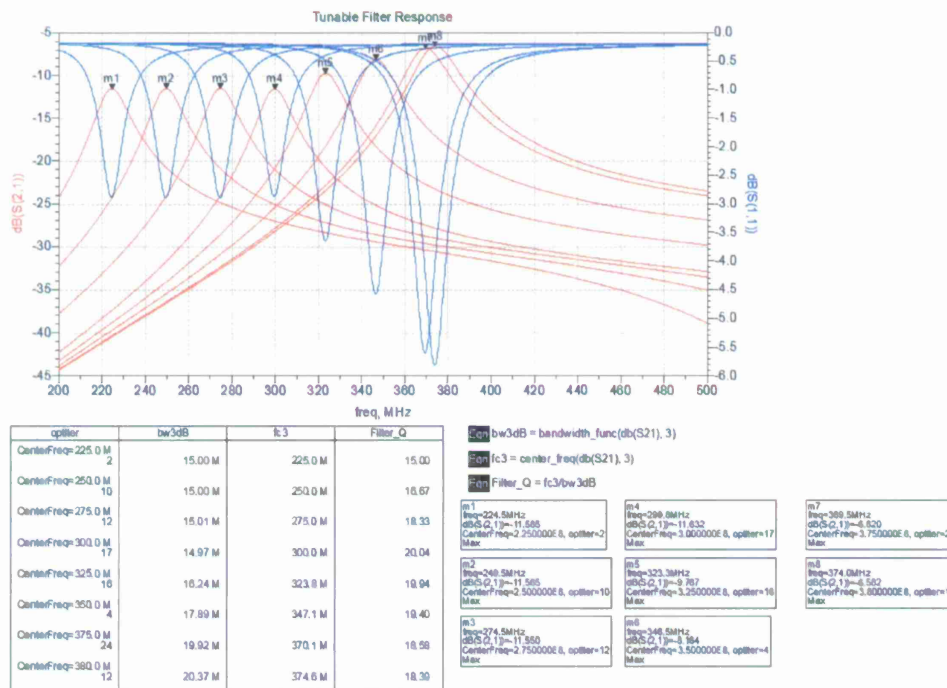

Figure 22. Tune range, filter bandwidth and tune voltages of tunable BPF

The design goal for center frequency is shown in the far left column. The 3dB BW goal was 15MHz. As can be seen, the BW widened as the frequency increased however the tunable coupling helps to minimize the change. Additionally the insertion loss changed from ~ -11.6dB @ 225MHz to -6.5dB @ 374MHz. The tune voltages were as follows:

CenterFreq_Tune	BW_Tune
CenterFreq=225.0 M 664.7 m	2.228
CenterFreq=250.0 M 1.493	3.878
CenterFreq=275.0 M 2.385	6.199
CenterFreq=300.0 M 3.337	9.786
CenterFreq=325.0 M 4.413	10.00
CenterFreq=350.0 M 5.576	10.00
CenterFreq=375.0 M 6.827	10.00
CenterFreq=380.0 M 7.088	10.00

Figure 23. Tune voltages

With the layout effects the following results were generated:

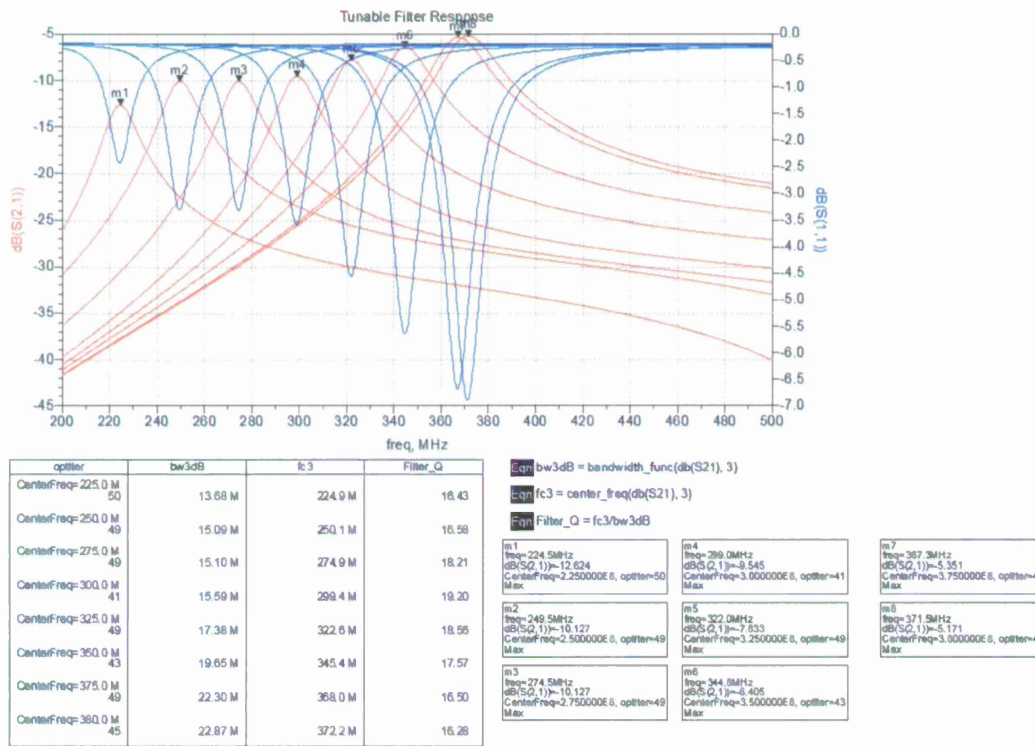

Figure 24. Tune range, filter bandwidth and tune voltages of tunable BPF, with layout

CenterFreq	Tune	BW_Tune
225.0 M	864.5	5.928
250.0 M	1.845	6.152
275.0 M	2.811	8.270
300.0 M	3.879	9.913
325.0 M	5.081	9.906
350.0 M	6.398	9.849
375.0 M	7.829	9.931
380.0 M	8.112	9.935

Figure 25. Tune voltages, with layout

### 2.1.7 Fabrication, Assembly and Debugging

Under this task, newly-fabricated, R.F. printed wiring boards (PWBs) were received and sent to the contract manufacturer, where they were populated with components to produce finished circuit card assemblies. Fully assembled R.F. circuit card assemblies were received in the Elintrix laboratory and hardware debugging and performance characterization efforts to establish proper operation were conducted.

### **2.1.8 Performance Characterization and Verification Testing**

The work performed included extensive characterization of the performance of the new design. Afterwards, revision 7 R.F. circuit card assemblies were paired and calibrated with existing digital circuit card assemblies. Laboratory and field tests were conducted to characterize the performance of the newly-paired radios with the Revision 7 R.F. boards. Board pairs were tested in the laboratory to validate that proper operation was achieved.

Characterization of the R.F. boards puts the transmit QPSK error vector magnitude (EVM) @ ~20dBm and 30+ dBm is ~5.3% assuming no oscillation in the transmit driver. The receiver sensitivity is on the order of -110dBm. That is based on a demodulated constellation from the analyzer with the recovered symbols in the proper quadrature.

Software routines to optimize the timing of the RF transmit activation/deactivation relative to packet transmissions were designed, implemented and verified. The optimization effort was successful. Highly beneficial reduction of the packet-error-rates observed during field-testing has resulted from the debugging effort.

## **2.2 Digital Design Improvements**

A range of work was executed to optimize the performance of elements of the digital CCA, including both hardware and software designs. The capabilities of the foundational design were adequate to meet demonstration requirements, but some remedial modifications were undertaken. The work increased the available number of radios to a level sufficient to conduct network and firmware testing for the full duration of the year 1, base year.

Debugging and calibration activity were conducted to repair some digital CCAs that were previously inoperable due to bad components. The eight boards that were required to conduct tests and demonstrations were made operational and available to support R&D activities.

Modifications aimed at improving the stability of driver-circuitry that supplies input signals to the analog-to-digital signal-conversion process were completed. Through investigative work, testing and collaboration with digital-to-analog (DAC) experts at Analog Devices, resolution to a distortion issue was achieved. This issue was resolved by adding small capacitors between the input pin of the DAC and ground. This modification restored the signal integrity of the DAC output to and eliminated the problems that affected the execution of Demonstration 1.

### **2.2.1 Improve Processor Access to Memory Resources**

The digital CCA design includes two, dual-core, fixed-point, Blackfin processors and one, single-core MSP430, digital signal controller. Modification to improve the flexibility of the design by providing the dual-core processors with improved access to memory resources was defined. Application notes from the manufacturers were analyzed to support communications between the hardware connections and of processor functionality optimization.

A booting-issue with the two dual-core fixed-point processors was discovered. It was identified that the serial peripheral interface (SPI) boot of DSP1 (1<sup>st</sup> processor) caused DSP2 (2<sup>nd</sup> processor) to boot with the same code. The two processors were being booted from a single SPI FLASH and DSP1 and DSP2 were configured as both SPI Masters. The intention was to modify the boot mode on DSP2 to SPI Slave and to have DSP1 load a different application code in to DSP2.

Because the memory space of DPS1 was adequate to support all operations required in Year 1 activity, and due to the pressing nature of other project-activities, the changes necessary to expand the capabilities of the dual-core processors, although fully defined, was postponed.

### **2.2.2 Digital Automatic Gain Control**

CCAs circuits were reworked to implement digital management of circuitry that was previously driven by analog circuits, placing adjustment of the on board, variable-gain-amplifier under the control of one of the two, dual-core processors.

### **2.2.3 Verification of Circuitry for Voice- and Text-applications**

Previously designed audio circuitry that resides on the digital CCA, aimed at supporting voice- and text-driven applications were debugged and verified.

The author of Handheld Speech (Amesbury, MA) was consulted in regards to the performance necessary to support its speech application-software. It was determined that additional work will be required to support the speech application-software. In particular, the bandwidth of the hardware design must exhibit a high-end corner-frequency of at least 8 kHz to ensure that the filter does not cut off before the microphone. It was recommended that the hardware design be modified to begin rolling off at 450 Hz and be strongly attenuated by 100 Hz.

The microphone filter/amplifier will require component value changes to adjust the bandwidth of the filters for application usage. The DAC filter will need to be redesigned. Software code will need to be written on the MSP430 or Blackfin to scale the DAC signal level. The microphone circuit is functional, except for the upper frequency, and also requires additional modifications to efficiently support the speech application.

There was an option to enable the current design to work with the application, but required digital filtering. The high pass filtering will need to be carried out in the digital domain. The microphone amplifier can operate with one OP-AMP and then will need to DC correct it into the analog-to-digital converter (ADC). It was determined that the manufacturer's part number, OPA209, would work the best for this application. Modifications to the circuitry were postponed until Option Year 1, where the digital CCA was scheduled for a design modifications and optimization of hardware elements.

The results of simulations were executed to define the required design changes are shown in Figure 26, Figure 27 and Figure 28, below.

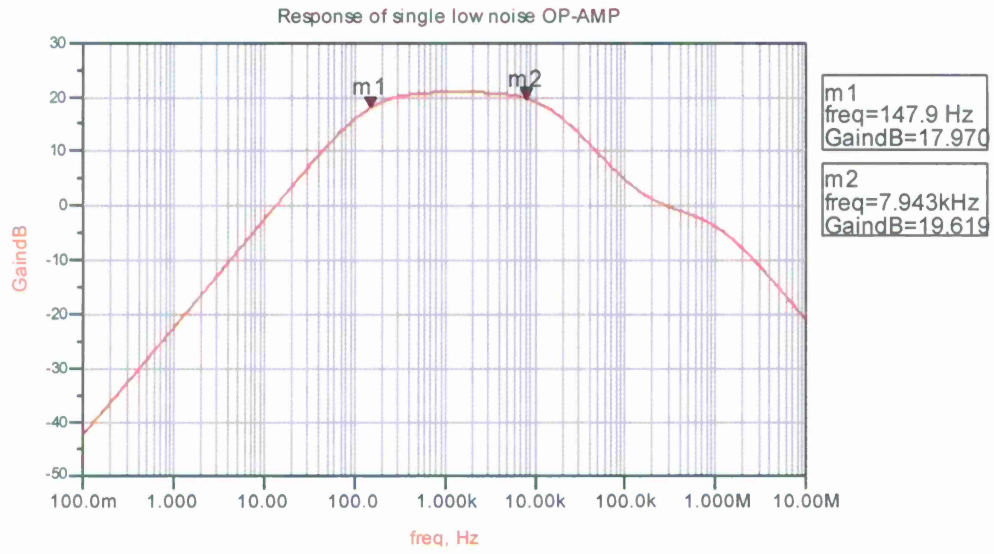

Figure 26. Response of OP-AMP

Digital filtering help is required. In this case 100kHz sample clock, 100Hz 40dB down,  $F_c=150\text{Hz}$ .

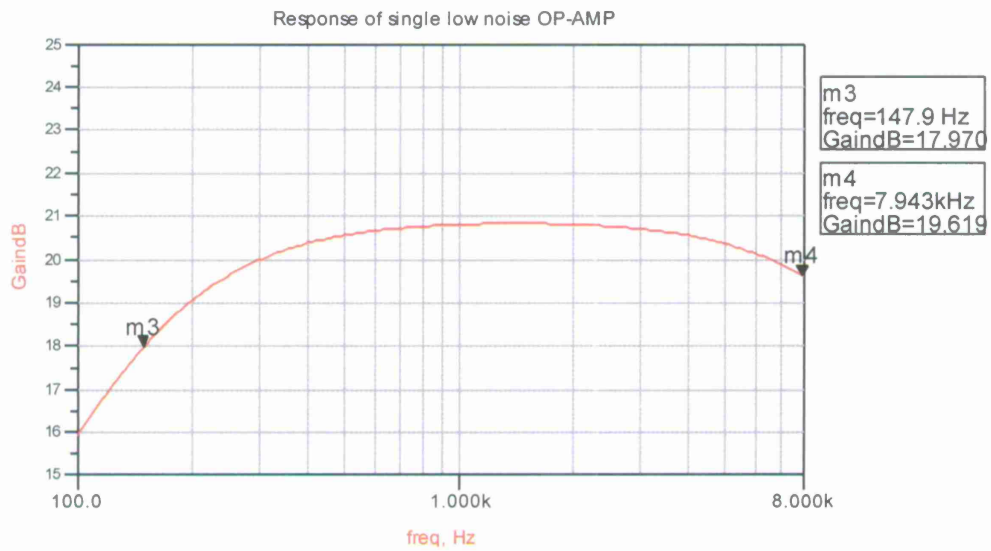

Figure 27. Response of OP-AMP, continued

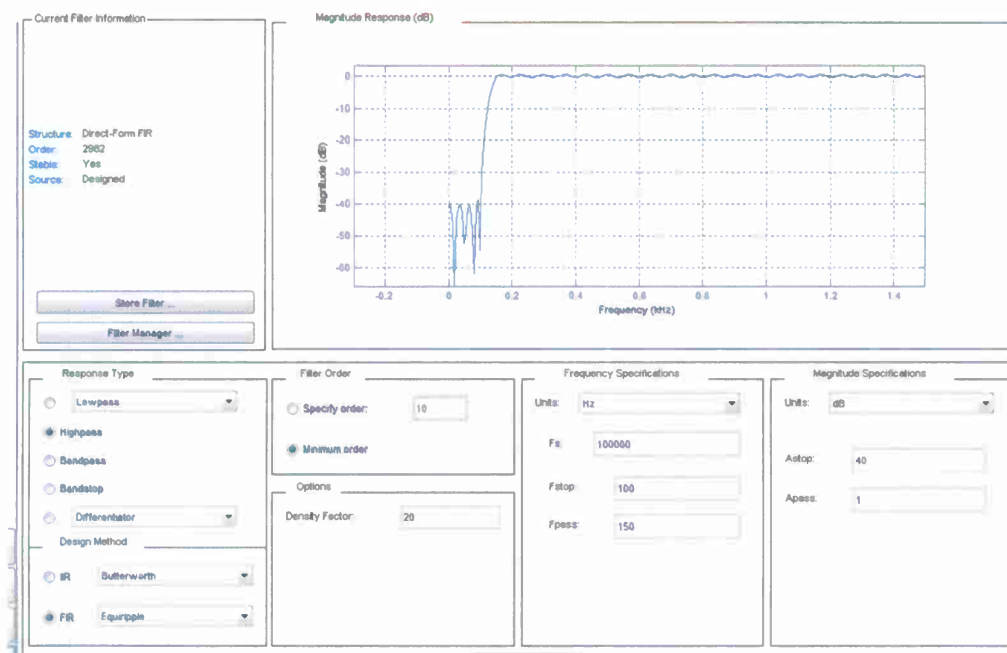

Figure 28. FIR version:

### 2.3 SDR Algorithm Improvements

SDR algorithm improvements were executed during this period, which included:

- Implementation of low-cost rework to eliminate intermittent distortion caused by the transmitter-chain digital-to-analog (DAC)
- Identified/eliminated intermittent down-conversion hand-off index error
- Identified/eliminated bug related to circular buffer used in data queue
- Implemented routine to improve precision of R.F. transmit activation/deactivation
- Implemented two-stage, digital, automatic-gain-control (AGC) to improve response to signal dynamics
- Introduced code to aid processing time budgeting of tasks within the main processing loop
- Corrected a radio boot-up issue in receiver, where errors were seen on first received packet
- Perfective work in the carrier lock detection scheme was completed. The scheme was revised to use a derivative-based metric for lock-detection
- Routines were amended to better control configuration of the R.F. board between transmit and receive states

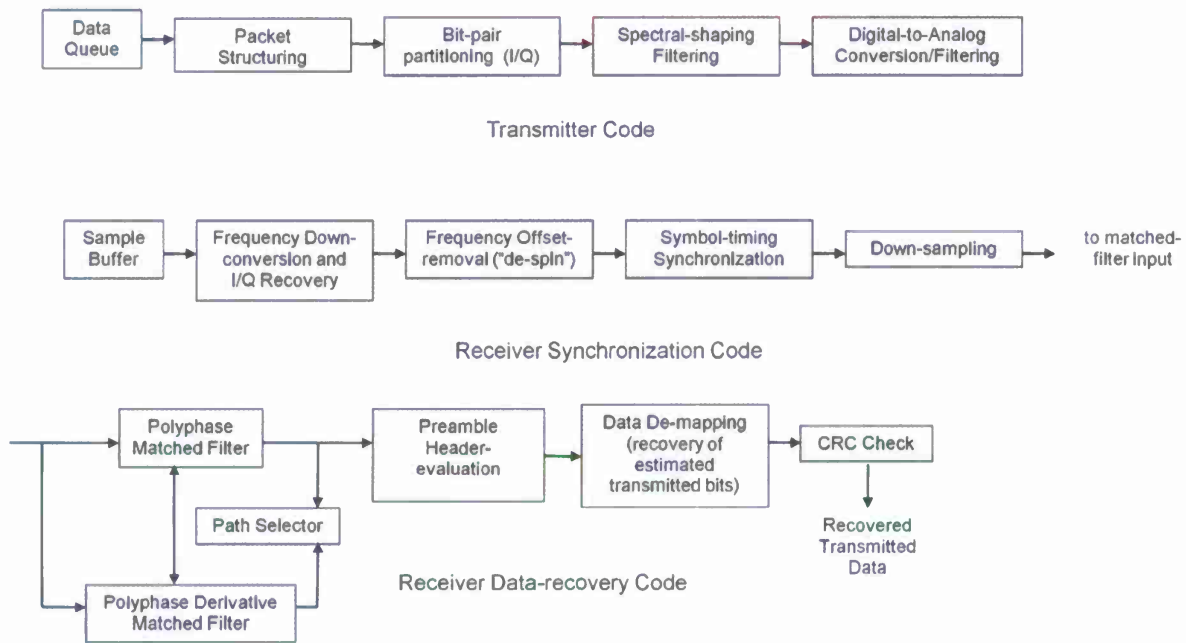

Figure 29. Notional SDR Code-module Relationships

### 2.3.1 Transmit Chain

An issue was discovered in the power-up state of the differential driver in the transmit-chain circuitry. The issue is related to dc offset levels of the differential lines and is only a concern for the first transmitted packet, following turn-on of the radio. Resolution was pursued and accomplished using a software fix.

### 2.3.2 Demodulator Carrier-Tracking

Code refactoring of the demodulator carrier-tracking loop was executed and improved packet-error-rate performance. Refinements to the direct digital synthesis (DDS) and phase error calculation algorithm for phase recovery were implemented and tested. Optimization of proportional and integral constants was performed.

### 2.3.3 Received Signal-strength Indicator (RSSI)

Work to replace the analog RSSI scheme with a digital methodology was undertaken and successfully completed. The digital approach relies on a new energy-calculation that is performed by the processor on the sampled-data stream. Adjustment of the averaging interval was used to achieve the desired smoothing. The RSSI value generated is used as a link fitness-parameter to decide when a new parent node should be engaged.

### 2.3.4 Improved Computational Efficiency

Work was executed to reduce the processing time required by some algorithms, particularly some standard functions in the processor library. Carrier-tracking performance was improved.

Characterization of processing-time required for data-packet transmit- and receive-transactions was performed. This work was conducted as part of verifying proper bi-directional communication

characteristics, such as validating message sequences between the instructor and student nodes. New opportunities to reduce processing-time were identified.

## **2.3.5 Digital Automatic Gain Control Algorithm**

### **2.3.5.1 Digital AGC Scheme**

An initial, improved algorithm for the digital control of the automatic gain control (AGC) was implemented. The code produced a metric that reflected the amount of gain-control applied to establish the proper maximum-amplitude of packet-samples. This metric forms part of the information provided to the network layer to facilitate evaluation of the suitability of transmitting-nodes as potential parent-nodes. Performance utilities integrated in the radio were used to capture and analyze packet sample-records under mobile conditions. These records were used to optimize the attack-rate of the algorithm.

### **2.3.5.2 Hybrid Automatic Gain Control (AGC)**

Experimental results suggested that digital management of the variable-gain amplifier (VGA) that provides initial AGC control would yield better results over a wider dynamic range of burst signals. A digital algorithm to control the variable-gain-amplifier was implemented, followed by a second, all-digital AGC module. Rapid, coarse adjustment is achieved using the variable-gain-amplifier AGC, while the all-digital implementation performs fine adjustments to the received signal.

The digitally-controlled VGA provides gain-control over a range of, approximately 44 dB. Currently, this control range modifies the amplitude of signals levels that fall between -30 dBm and -74 dBm. The all-digital AGC provides fine-grained attenuation/amplification of the output signal of the VGA, permitting operation on signal levels below -74 dBm.

## **2.4 Software Improvements**

### **2.4.1 Power Management**

Power savings on the digital CCA circuitry were advanced. Functions were created to modify the Blackfin core voltage and frequency, which saw a 66mA (milliamps) 7.2V battery current savings going from 500MHz at 1.3V core to 250MHz 0.85V core. Another savings of 30mA of 7.2V battery current in the MSP430 audio circuit was harvested by activating a DAC on the MSP430 code. The Blackfin serial peripheral interface (SPI) boot time was decreased from 12 seconds to approximately 0.5 seconds. This was accomplished by composing an assembly language routine to modify the Blackfin SPI clock during SPI FLASH boot. The MSP430 code was also enhanced to support the faster Blackfin boot process. The MSP430 now validates that the Blackfin boots successfully by monitoring the SPI bus for activity and sending an SPI "PING" command. If the PING is not received, the MSP430 will reset the Blackfin to boot again. A function was created for the MSP430 to switch the MSP430 core voltage between +2.2V and +3.3V.

There are several other power savings modifications to be made on the hardware and software. For instance, the R.F. board circuitry can be powered down when not in use. Multiple cores can be used to further reduce clock-speed and core voltage. Other power management algorithms, such as using information from the network layer to schedule use of low-power and standby-mode operation, and network algorithms to establish topologies that minimize power-consumption are planned for future implementation.

## 2.4.2 Enhanced Support for Field Testing

Assessment tools were designed and integrated into the code to aid in characterizing the performance of the individual radios, support regression testing and generally reduce the amount of time required to gain essential insights into indoor and outdoor radio-performance. Past field testing has underscored the desirability of having an improved means of evaluating SPARNET performance, in the field. Accordingly, the ability to store, retrieve, display and analyze packet sample-records under mobile, dismounted conditions was achieved. A packet-error utility which enables in-field triggering on packet errors and simultaneous storage of various signal buffers for subsequent analysis was completed. It triggers on specific types of packet errors and provides for storage of the contents of key buffers. This enables subsequent, detailed analysis of the contents of signal-buffer contents, along the entire processing-chain, to identify the cause of the error and any anomalous algorithmic behavior that may be occurring. This added functionality allows for a “trigger” capability. This trigger capability will allow us to zero in on a specific set of errors and programmable to any parameter of interest. This assisted in perfective work on both software and hardware elements, and opened the way to detailed channel-characterization studies that provided information that was leveraged to improve the SAN radio elements and applications. A command-line-interface (CLI) trigger was added to “dump” contents of packet errors relative to ADC, despun and Matched Filter captured data. A counter was also introduced in the code which provides the number of times a specific case of error was experienced when the radio is powered on and is receiving packets – data packets and/or test packets.

A range of error-detection mechanisms are built into the radio algorithms, to aid in detecting, analyzing and resolving performance issues. These mechanisms can detect issue such as failure to properly decode the packet (manifested as cyclic-redundancy-check, CRC, errors) failure to resolve ambiguity that is a normal part of the synchronization process in quadrature receivers and failure to properly achieve phase-synchronization in a timely manner (“preamble” errors). Under normal operation, these types of errors can be expected to occur when the received signal has been sufficiently degraded by the channel.

Performance metrics integrated in the radio algorithm to capture and analyze packet sample-records under mobile, dismounted conditions were constructed, to determine the cause of the errors. This function is able to be commanded over the CLI. See below for an example.

By typing “dumptrig” command via the CLI, the choices of specific cases of errors will be listed.

```
[29:37] sparnetP3>dumptrig
[29:42]   DUMPTRIG CHOICES
[29:42]   =====
[29:42]   0 = Turn OFF Trigger
[29:42]   1 = Preamble Map Error
[29:42]   2 = SNR Error
[29:42]   3 = Pkt Length Long
[29:42]   4 = Pkt Length Short
[29:42]   g_dumpTrig = 0
[29:42] sparnetP3>[29:42] @
```

Typing “dumptrig” and the number corresponding to the packet error case will be selected.

```
[30:53] sparnetP3>
[30:56] sparnetP3>[30:56] dumptrig 1
[31: 0] sparnetP3>[31: 4] dumptrig
[31: 6]   DUMPTRIG CHOICES
[31: 6]   =====
```

## For Official Use Only (FOUO)

```
[31: 6] 0 = Turn OFF Trigger
[31: 6] 1 = Preamble Map Error
[31: 6] 2 = SNR Error
[31: 6] 3 = Pkt Length Long
[31: 6] 4 = Pkt Length Short
[31: 6] g_dumpTrig = 1
[31: 6] sparnetP3>[31: 6] @
```

Once the trigger is enabled and the parameter is chosen, the "dump" command is used to discharge the contents of the packet error relative to the specifications listed below.

```
[33:41] sparnetP3>dump
DUMP CHOICES (time)
=====
0 = Raw ADC12
1 = 16-bit ADC12
2 = Despun Samples
3 = Despun 8th Samples
4 = MF inputs
5 = MF outputs
```

Supplementary Digital and R.F. CCA's were fabricated and assembled to provide additional squad-area-network (SAN) radios for field and laboratory testing. In order to increase the span of testing, the routine that is used to prepare and load packets for transmission was re-factored so that test packets would undergo handling that employed the same code used in actual network packets. This was useful in identifying data-handling bugs, which were only manifested in the network mode of operation.

### 2.4.3 Liquid-crystal-display (LCD) Integration

Code modifications to integrate the Liquid-crystal-display (LCD) to the SAN radio were engineered, implemented, tested and integrated into the SAN radios. The code displays 8 rows of 17 characters (ASCII 0 to 127) on the LCD with a modified version of the CLI *printf* function. The LCD has the capability to display the synthesized Elintrix and USARIEM graphic logos, as illustrated below. There are several other text messages stored in the MSP430 memory that can be used for test purposes, via the LCD CLI command.



Figure 30. Synthesized "Elintrix" logo on SAN radio LCD

## For Official Use Only (FOUO)

Each mobile radio node has been fitted with an LCD unit. Code was produced to continuously display parameters of interest. Information displayed via the LCD includes:

- a. Node latitude and longitude
- b. UTC time
- c. Battery status
- d. Transmission frequency
- e. Parent-node identification
- f. Link-strength indication-metric
- g. Number of GPS satellites acquired
- h. 911 status (on, off, acknowledged)
- i. Heart rate

The incorporation of the LCD enabled satisfaction of the requirement set forth for Demonstration 2, paragraph 2e of the PWS which states: "Demonstrate the display of all required information at each Student Node and Instructor Node".

### **2.4.3.1 Mechanical Enhancements**

Mechanical modifications of the radio enclosures to support incorporation of the LCD displays were accomplished. Acrylic screens were designed and fabricated, as well as modifications to the case to accommodate screen cut-outs. Metalized mirrors for screen backing to improve contrast and block printed circuit board (PCB) from showing through the screen were also fabricated. Other mechanical optimizations relative to the battery packs and power/911 switches were executed.

### **2.4.4 911 Messaging**

Bi-directional messaging was demonstrated using 911-messages that were originated by the individual field nodes and responses generated by the TOC node. Currently, 911 messages are sent during the unique time-slot that is assigned to each radio.

When a node transmits a 911 alert by depressing the designated push button of the SAN radio, the alerting node's icon color scheme turns from green to red, as represented in Figure 31. The student icon is symbolized by an isosceles triangle that is colored green if the last data packet received was successfully routed to the TOC node.

A red icon indicates that a participant has pressed their 911-emergency push button and may also indicate that a critical threshold has been exceeded. Both the instructor's handheld tablet application and the TOC application have audible tones that accompany the 911 alert once it is enabled by the alerting node and received by the applications.

In Figure 32 a snapshot of the alert tab configuration window within the TOC application has been extracted which furnishes the time to which the TOC application/database receives the corresponding node's 911 alert activation.



Figure 31. Map Application Node Coloring Scheme

Co/PI/Sq	Alert	Details	Alert Date	Duration
A/1/1	911 EMERGENCY		2/2/2012 1:11 PM	0h 10m 28s
A/1/1	911 EMERGENCY		2/2/2012 1:00 PM	0h 09m 29s
A/1/1	911 EMERGENCY		2/2/2012 12:05 PM	0h 00m 59s
A/1/1	911 EMERGENCY		2/2/2012 12:01 PM	0h 01m 30s
A/1/1	911 EMERGENCY		2/2/2012 11:56 AM	0h 03m 30s
A/1/1	911 EMERGENCY		2/2/2012 11:52 AM	0h 01m 30s
A/1/1	911 EMERGENCY		2/2/2012 11:48 AM	0h 01m 30s
A/1/1	911 EMERGENCY		2/2/2012 11:44 AM	0h 01m 28s
A/1/1	911 EMERGENCY		2/1/2012 5:26 PM	0h 10m 30s
A/1/1	911 EMERGENCY		2/1/2012 4:52 PM	0h 01m 30s
A/1/1	Instructor Distance	75.3 meters from instructor.	2/1/2012 4:52 PM	0h 00m 12s
A/1/1	Instructor Distance	252.4 meters from instructor.	2/1/2012 4:52 PM	0h 00m 19s
A/1/1	Instructor Distance	274.3 meters from instructor.	2/1/2012 4:52 PM	0h 00m 22s
A/1/1	Instructor Distance	153.3 meters from instructor.	2/1/2012 4:52 PM	0h 00m 27s
A/1/1	Instructor Distance	93.8 meters from instructor.	2/1/2012 4:52 PM	0h 00m 31s

Figure 32. Alert Window Displayed via TOC application for Bi-directional 911 Messaging

#### **2.4.5 GPS 1 Pulse-Per-Second (PPS) Interrupt Callback**

With the objective of implementing a time-domain multiple access (TDMA) medium access control system, individual network node time is derived from the 1 PPS signal available from the on-board GPS module. The current Elintrix end-node hardware platform includes a GPS module type Trimble Copernicus II (Sunnyvale, CA). This module provides a 1 PPS signal line that generates a pulse with an rms error of +/- 60 ns. This signal is available in each network node; therefore overall network timing synchronization can be achieved. This feature is particularly useful for a medium access mechanism based on TDMA. Although not the only method of attaining network level synchronization, the availability of GPS time reference on each node provides additional benefits when compared to other synchronization methods.

By typical design and implementation, network devices contain a local clock source with certain associated stability (usually specified in parts-per-million). The objective of the time synchronization subsystem is to discipline this clock source to the incoming 1 PPS GPS signal. The target was to obtain a time reference that provides a highly stable source at the required rate. The current platform required a software approach without further hardware modifications. For the software case, the rising edge of the incoming 1 PPS signal is used to generate an interrupt in the processor (Blackfin). This event is the reference to perform adjustments on a counter that provides the signal to be adjusted. Test processes were developed to support field testing and demonstration activities. Enhancements to GPS time-keeping to sustain node-timing during periods of GPS-outage were made.

The driver for the GPS 1 pulse-per-second (PPS), an interrupt service routine which synchronizes the PPS interrupt to the Blackfin processor counter was completed and integrated. A code was created to synchronize Timer1 from the Blackfin processor to 1PPS of the GPS module with elapsed time calculation. Individual network node time is derived from the 1PPS signal available from the on-board GPS module. This allowed network timing synchronization to be achieved.

A timing scheme was generated and integrated to synchronize the network messages to the Blackfin counter. Additional code will need to be created to synchronize Blackfin Timer1 to 1PPS and UTC time. This requires writing driver to communicate with the GPS module. Set-up is currently set to only listen.

#### **2.4.6 Data Packet Payload Length**

Based on discussions with USARIEM, Handheld Speech and internal engineers, an initially-used 32-byte packet payload was increased to 64-byte packet payload for use in tests and demonstrations. This longer packet accommodates time stamp information, as well as, latitude, longitude, fluid-intake information, accelerometer data, inclinometer data and reserved bytes for currently-undefined physiologic sensor data. Future modifications can be gracefully implemented, as may be required.

##### **2.4.6.1 Data Packet Definition**

Network message-sequence diagrams and data packet definitions for messages required for registration between Student Nodes and Instructor nodes were analyzed with the objective of improving support for test-relevant field-data.

SPARNET network DATA packets currently provide the following information

- Timestamp (Hour, Minute, Second)
- Network ID

## For Official Use Only (FOUO)

- Node ID (corresponds to time slot)
- Emergency state (ON, OFF, ACK)
- Latitude Hemisphere
- Latitude Coordinate
- Longitude Hemisphere
- Longitude Coordinate
- Fluid Intake Monitor data (mL consumed)
- Battery level (Good, Warning, Critical)
- Parent node slot
- Registration time (time at which first INVITATION was sent (Instructors) or time of most recent parent registration (Students))

Some parameters require fewer bits than the byte-length currently assigned to them. In the future, when the parameter-list and lengths have stabilized, bits will be packed into fields that will not necessarily be increments of one byte.

### **2.4.7 Flash Storage and Download**

An architectural design for storage, formatting, downloading and subsequent exporting of data stored on an individual node was devised. During network operations, each radio stored the content all data packet information that are self-originated. The storage medium is FLASH memory.

An RS-232 cable is currently used to connect to the Bluetooth dongle and establish a Bluetooth connection between the radio and the tablet. This cable is used to download the stored data from each node to a Windows-based PC.

#### **2.4.7.1 Decoding of Downloaded FLASH Packet**

The first step in exporting the stored data and information from the individual nodes is to “dump” the FLASH log file via HyperTerminal. HyperTerminal is a terminal emulation program capable of connecting to systems through TCP/IP Networks, Dial-Up Modems, and COM ports. HyperTerminal works when directly connected to the radio CLI.

Below are steps to create a HyperTerminal log of FLASH log dump.

For Official Use Only (FOUO)

- 1) Start HyperTerminal and connect to radio CLI COM port with 57600 N,8,1 and no flow control.

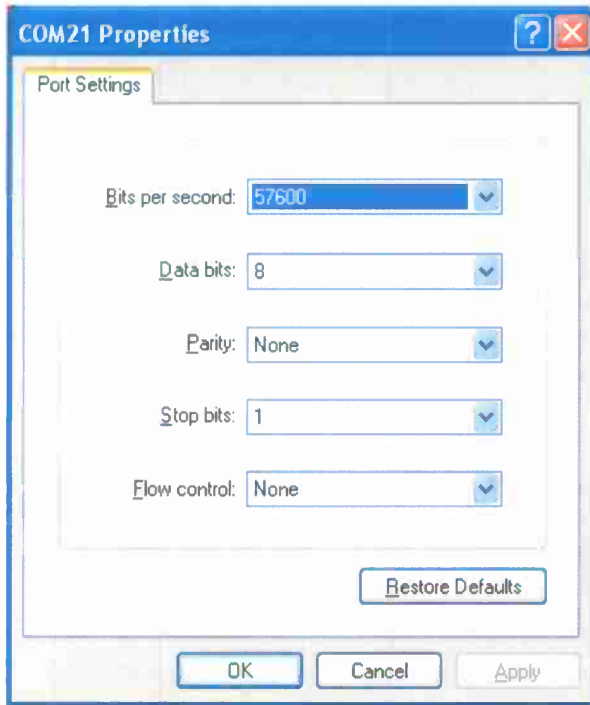

- 2) Select Capture Text from Transfer menu.

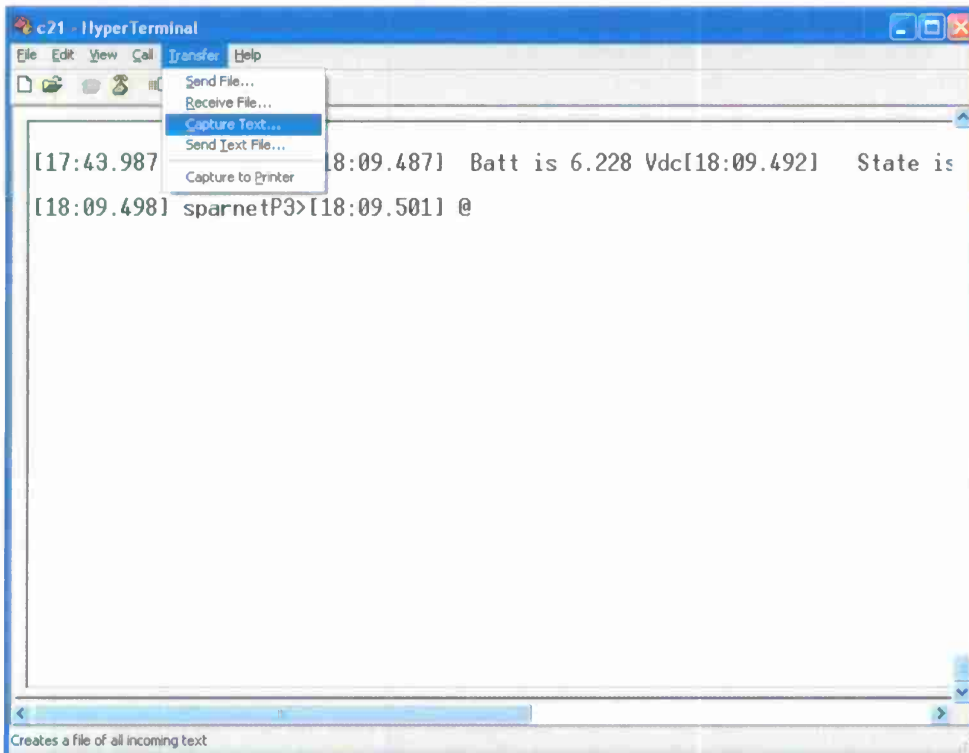

3) Select filename for log and select Start:

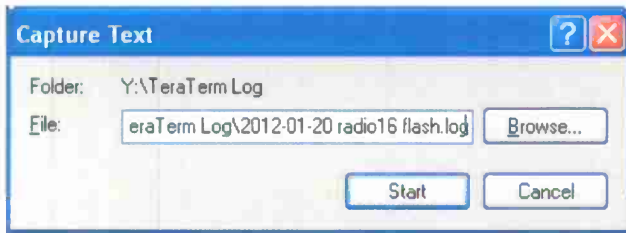

4) Enter "dump 8" to start FLASH dump.. In the example below 18,750 bytes will be downloaded from FLASH:

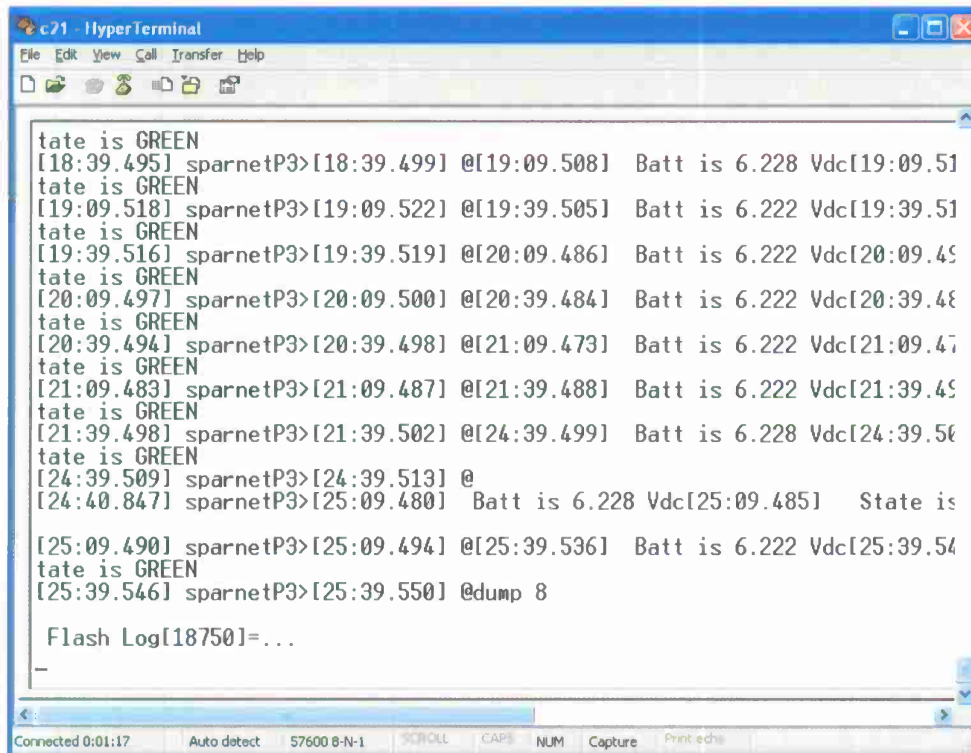

5) At end of FLASH log dump, the message Dump#8 Success!!! will appear:

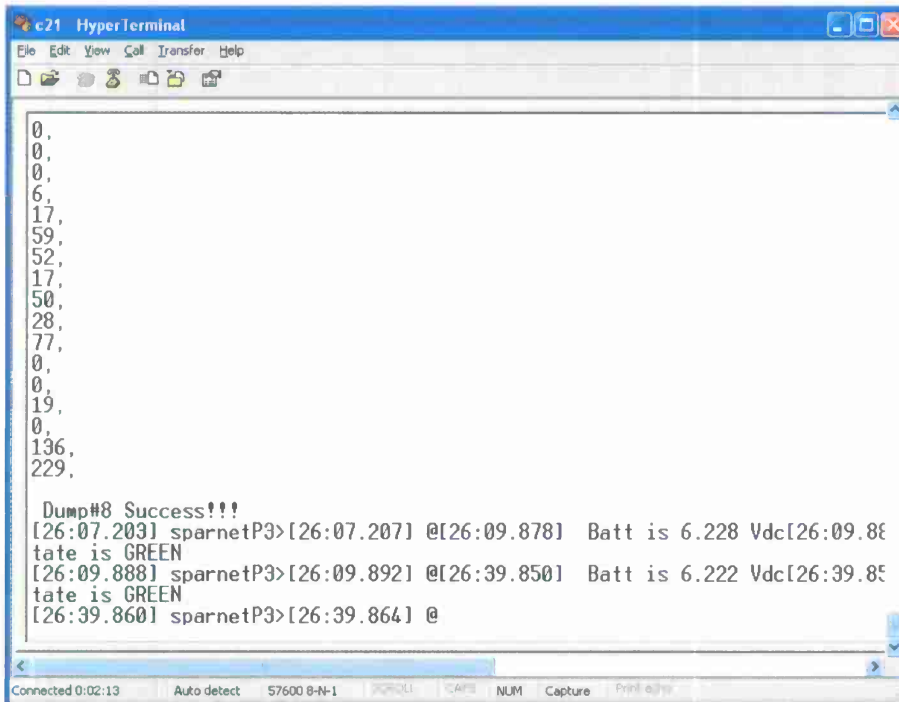

6) Then close the log file by selecting Stop as indicated below:

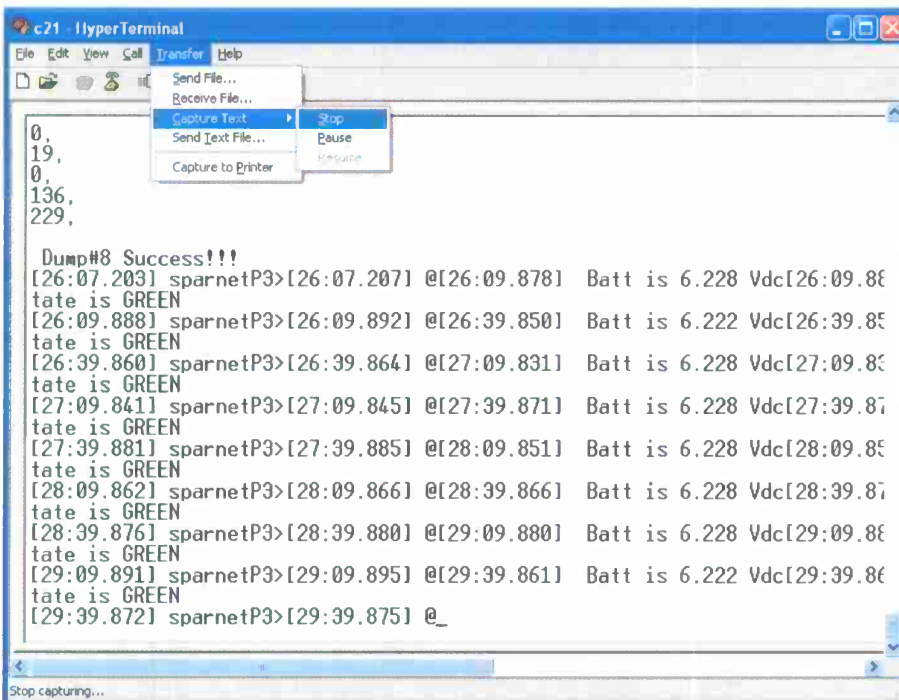

7) Next step will be to examine contents of the FLASH log file using Parsing tool.

#### 2.4.7.2 Python Parsing Tool

A parsing tool was devised to provide the capability to make the downloaded FLASH files in to a readable format. This was implemented using a Python parser for the Flash dump to be performed on any Windows PC.

Currently, a raw Flash data file consists of a text header, multiple 50 byte packets for a given SPARNET radio, and text footer. A given line of the packet data consists of one integer followed by a comma and there is no distinguishing character that separates one packet from another. A 50 byte packet consists of a 12 byte header, a 36 byte payload, and a 2 byte CRC.

The utility parses the raw Flash data into a form that distinguishes one packet from another and for a given packet, separates the header from the payload. As each packet is 50 bytes in length, the script loops through the dumped FLASH file, buffers increments of 50 bytes, and processes the resulting buffer. The output is a text file which is a cluster of individual parsed packet data.

A GUI (graphical user interface) has been constructed to streamline the processes outlined above. Below are screenshots of the GUI and the steps to parse the dump of the FLASH file.

1) Start the software:

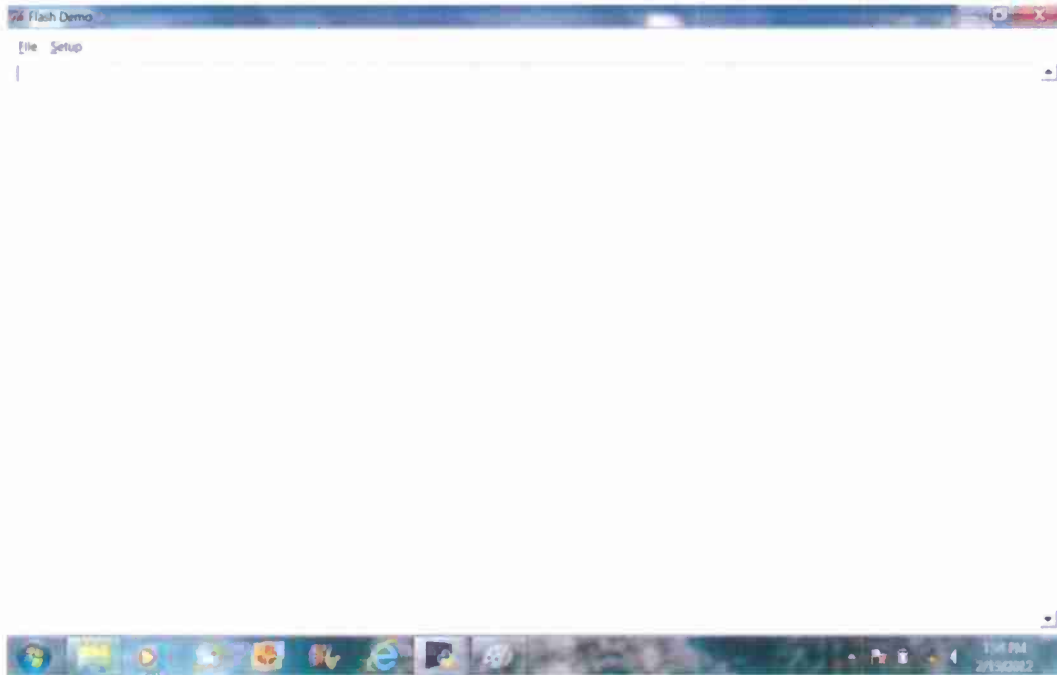

2) Select File from the main menu.

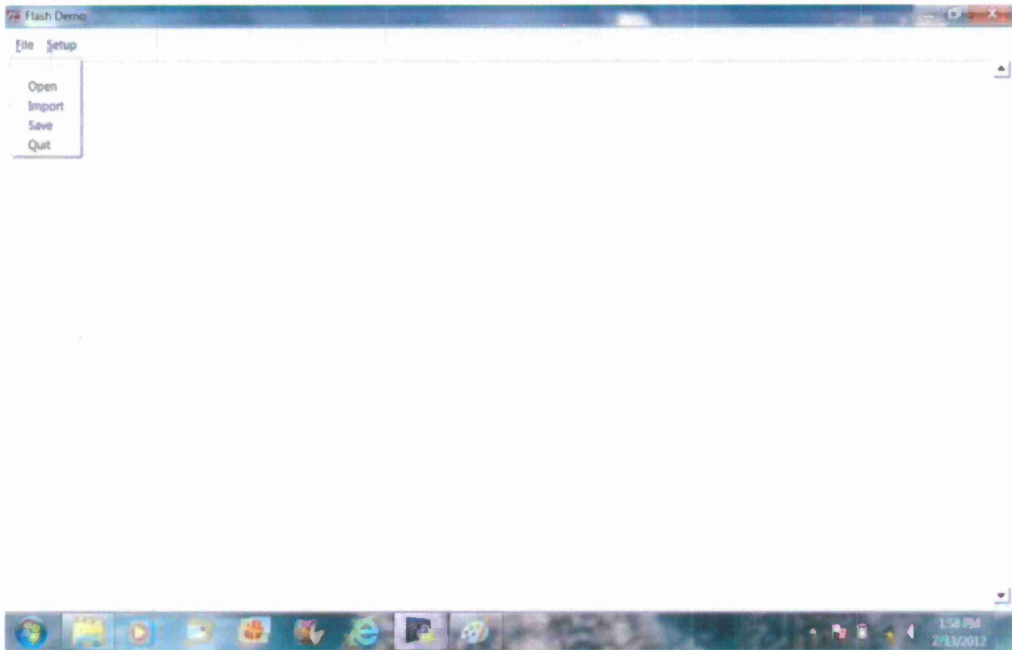

3) Select Import from the File drop-down menu.

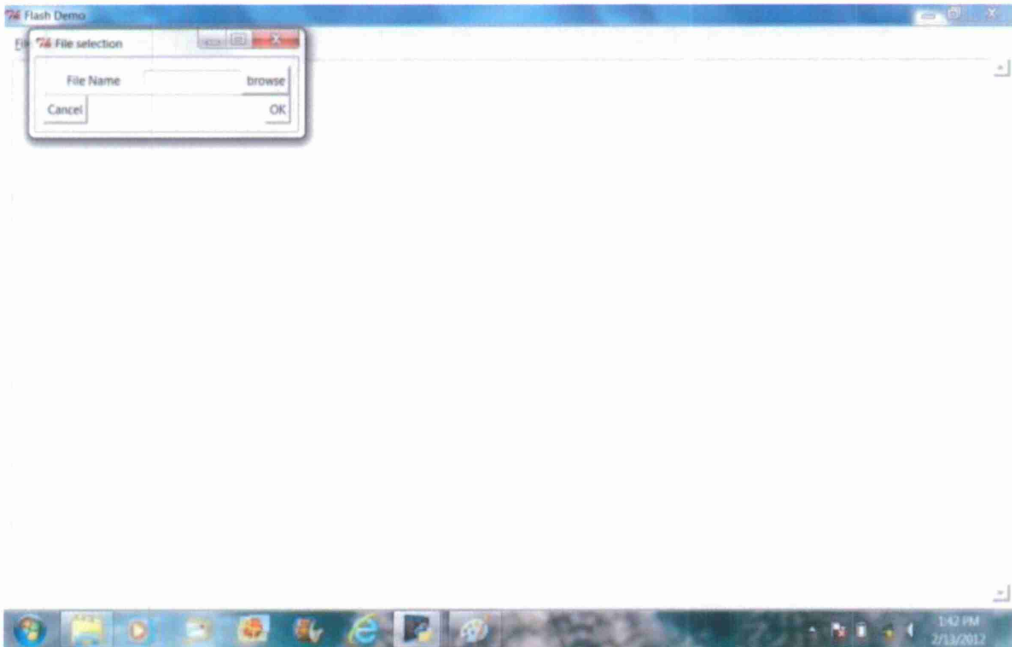

4) Click the browse button and select the file.

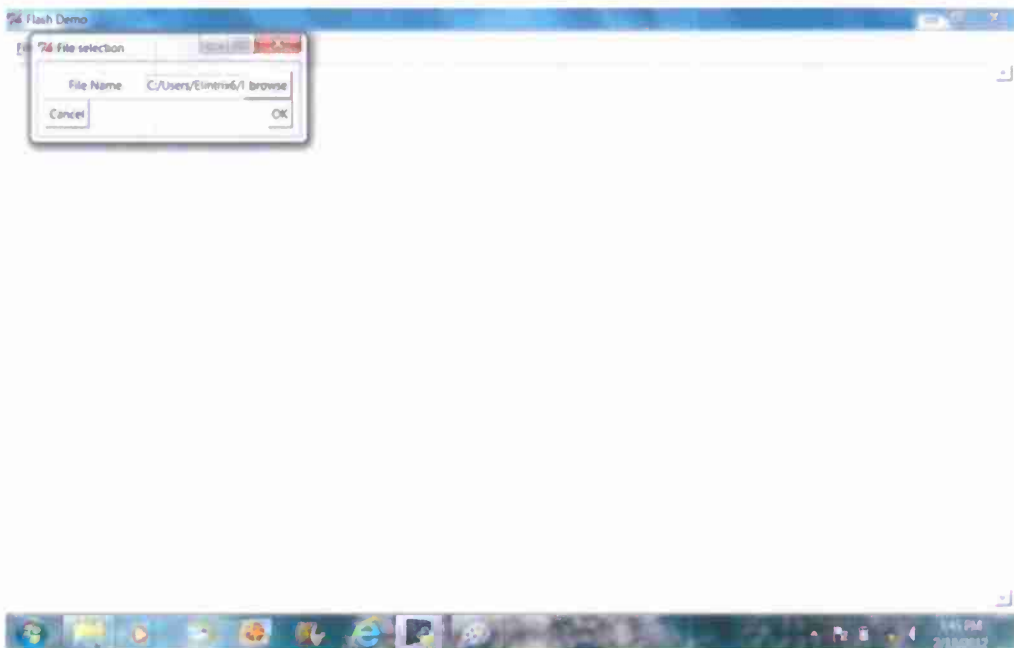

5) Click the OK button on the file selection pop up.

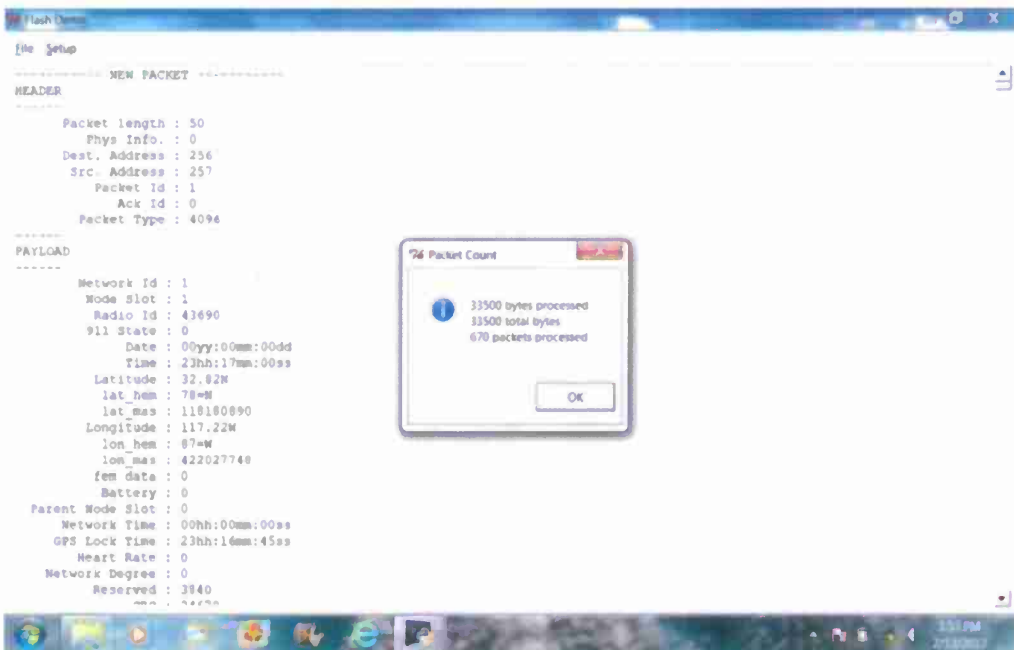

## For Official Use Only (FOUO)

The two images below present functionalities that have been incorporated into the parser after the execution of Demonstration 4. Namely, instead of using HyperTerminal to import data from the radio, we can use the Python parser itself. The functionality was built in at the time. A script was already produced to read data directly from the serial port in Python. The enhanced code required additional test time prior to full integration and with little bandwidth left prior to the execution of Demonstration 4, inclusion was deferred.

### 1) Setup drop-down menu.

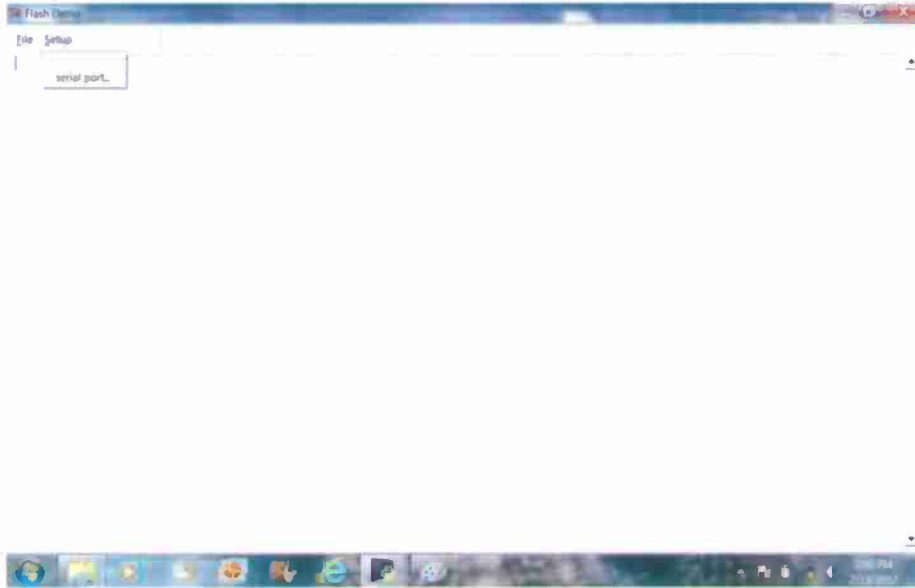

### 2) Serial configuration popup.

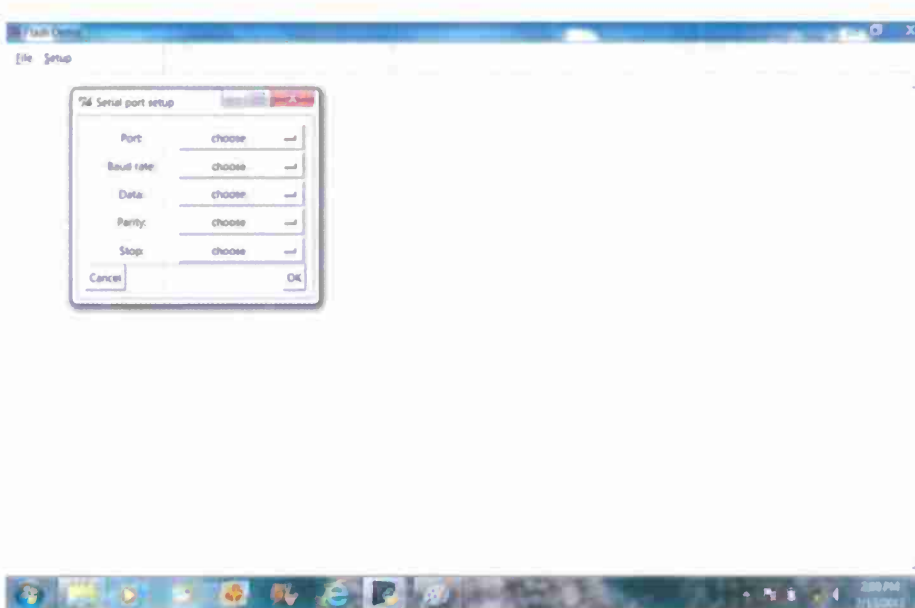

### 3 Bluetooth Option Card Development

A Bluetooth option-board was designed and implemented which enabled wireless connection to heart-rate monitors. The Bluetooth link was executed to satisfy the requirements set forth for Demonstration 3 of the PWS.

#### 3.1 Development of Bluetooth Board

Bluetooth-enabled option-card schematic was designed and advanced to meet the Demonstration 3 requirement of exhibiting near real-time availability of Bluetooth-connected on-body student sensor information at the Instructor node and TOC node. In addition to a standard Bluetooth module, a Bluetooth Low Energy module was designed into the board. The Bluetooth option-card, shown in Figure 33, was successfully advanced through design, layout, fabrication and assembly.

In Figure 33, two, standard, Bluetooth modules appear as large, silver-colored, rectangular packages, bounding the rectangular cut-out at the upper, left corner of the CCA. The left-most of these is a break-off board that permits remote mounting, if required, in confined spaces within the SAN radio enclosure. This provides flexibility in relocating the module, should interference or blocking effect the other, primary module. A Bluetooth Low-energy (BLE) component occupies the dark area above the left-bottom, gold-plated, mounting hole. This module will enable research using newer BLE-equipped modules that are anticipated to appear on the market in 2012. The Bluetooth board was successfully debugged, tested and integrated with the digital Board of the SAN radio.

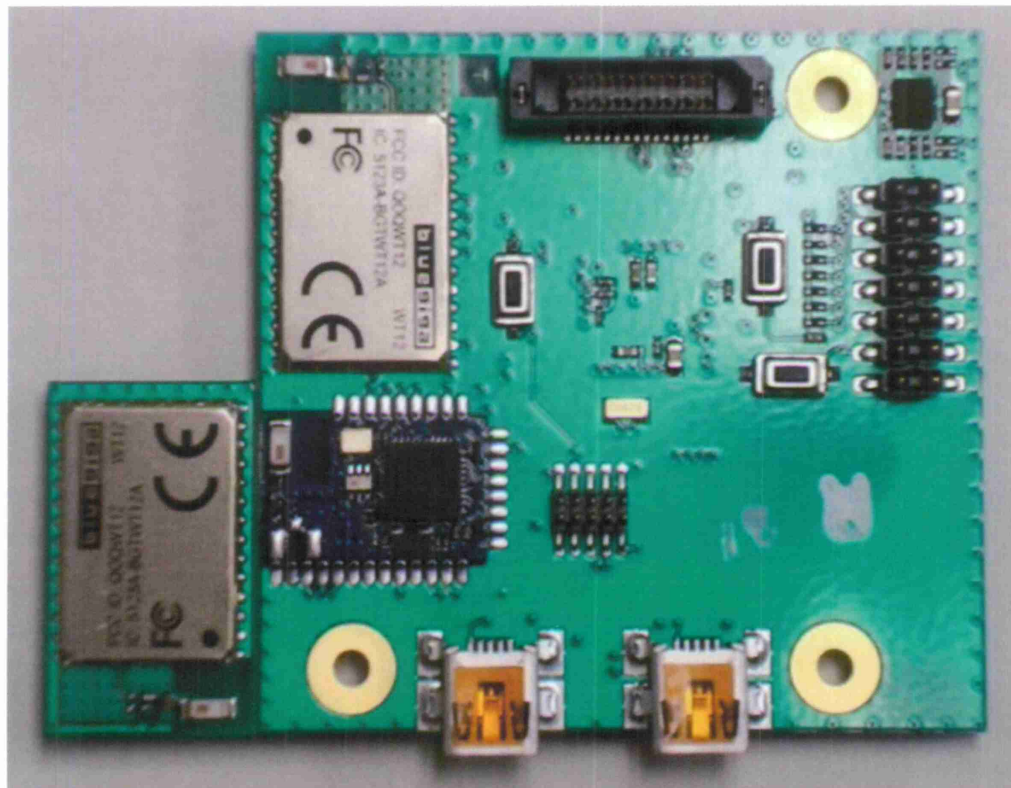

Figure 33. Fully-assembled Bluetooth Option-card CCA with Break-off Bluetooth Module

## **3.2 Sensor Collaborators**

Elintrix conducted collaborative discussions with Polar and Zephyr to obtain the permissions, documents and code necessary to establish Bluetooth connectivity with their respective products.

An alternative to the Zephyr/POLAR sensors was the fluid intake monitor (FIM). It can be connected to the Bluetooth board/dongle which can communicate with that the Bluetooth board for use in the radio. The hardware and software needed for transactions between the radio and FIM, transmission of the FIM data, reception and display are completed and available.

### **3.2.1 Zephyr Protocol**

Engineering conversations with Zephyr were conducted to define the best reporting-option for the SPARNET system. Considerations included the time-span retrieved during interrogation of the BioHarness sensor and the potential for blocking of the SPARNET Squad Area Network (SAN) radio by out-of-band emissions produced by the Bluetooth transmitters.

With respect to co-site interference produced by the Bluetooth modules, Zephyr technologists have never experienced this problem. Nonetheless, an engineering discussion proceeded. Based on the results of this discussion, an operational mode in which link-maintenance transmissions are periodically executed was selected as the first method tested.

Zephyr software was not received as early as needed to support the integration and testing schedule. So, the integration of a POLAR heart-rate monitor was executed to satisfy the Demonstration 3 requirements. POLAR heart-rate monitors were used during the back-to-back executions of Demonstration 2 and Demonstration 3. Subsequently, in support of Demonstration 4, the Zephyr BioHarness 3 product was successfully integrated.

The integration of Zephyr BioHarness 3 units was facilitated with the aid of a senior, Zephyr, embedded engineer tasked to assist us with integration. Although not displayed, parameters other than heart rate (such as respiration rate, accelerometer and inclinometer data) are being interrogated and are available within the SAN radio for subsequent incorporation into the data packet.

#### **3.2.1.1 Zephyr BioGauge Application Software**

Zephyr's BioGauge software was leveraged to connect directly to the on-body heart rate sensors of the individual trainee nodes. The purpose was to pair each Zephyr heart rate unit to the instructor's mobile device using this application. Each student node's Zephyr heart rate was associated with the Bluetooth name that displays on the connection screen inside the application. This eliminated the need to manually pair the heart rate units by determining which COM port each BioHarness happened to enumerate on upon discovery. This was accomplished by terminating the SAN radio's Bluetooth link to the Zephyr units by powering off the radio units.

### **3.2.2 POLAR Protocol**

Following execution of a Bluetooth Transfer Protocol License Agreement with POLAR, Elintrix was immediately provided with POLAR-Proprietary documentation. The documents include software design guidelines, format information, flow charts and script examples that enabled the development of a SPARNET-specific communication-link with POLAR monitors.

### 3.3 Bluetooth Software Development

Work on a range of software drivers that were required to facilitate communication between the new, Bluetooth circuit card assembly (CCA) and the digital CCA were executed. The connectivity between the Bluetooth board and the radio's digital board was established. Communication of heart-rate information between the SAN radio processors (MSP430 & Analog Device's Blackfin) was implemented. This included enhancements to the MSP430 command line interface (CLI). Modification of the scheme from polling to interrupt-drive was performed. These modifications were incorporated into the Bluetooth Option board and Digital Board MSP430 processors.

The serial peripheral interface (SPI) messages were created to accommodate the communication link between the MSP430 and Blackfin. MSP430 interrupts were modified to properly transmit and receive clocked data between the processors.

Parsed "call" response from the Bluetooth chip module to show a successful connectivity and to send a response to the Blackfin was constructed. A scheme was created to determine if the Bluetooth radio was in "command" or "data" mode and to provide notification if connectivity is dropped by the Bluetooth module. A "call" disconnect was implemented which will send a parsed response to the Blackfin processor.

Code to enable the use of the POLAR heart rate monitor and the subsequent integration of the Zephyr heart-rate monitor were loaded onto the Bluetooth radio boards and then fully-integrated into the SAN radio units.

### 3.4 Issues

The introduction of Bluetooth-enabled heart-rate monitoring and the 10" tablets into the network resulted in unexpected, randomly-occurring issues with radios, during Demonstration 2 and Demonstration 3. Information-display rate/volume in field-testing has been increased, making Personal Digital Assistants (PDAs) impractical for continued use in viewing on-the-fly communication and topological information in the field. Accordingly, the PDAs have been replaced with 10" Tablets (operating with Windows) to allow real-time observation of command-line-interface (CLI) messages, link-quality and node-performance. Collectively, this information is required to facilitate formation of specific topologies for testing. It is also worth noting that PDA devices, such as the Hewlett-Packard iPAQ (Palo Alto, CA) products that have historically been used in the system have been discontinued by the manufacturer, as Android-based (Google) (Menlo Park, CA) smart phones are consuming market-share.

Issues relative to the Bluetooth code were resolved during this period. Connectivity related issues, as well as synchronization issues between the MSP430 processor and the Bluetooth WT12 chip module in the Bluetooth Option board was investigated and corrected. Serial peripheral interface (SPI) communication between the MSP430 and Blackfin processors was further enhanced by lengthening the SPI message format from two byte length field to one byte. The issue of when the Blackfin supplied an SPI clock to slave MSP430, both MSP430 SPIs that resided on the Bluetooth option CCA and the digital CCA transmitted and received clocked data. It was resolved by improving the MSP430 SPI interrupts.

## 4 Network Software R&D

Mobile ad-hoc networks for highly dynamic military and civilian environments, such as tactical and rescue mission communication, exhibit several design considerations that do not exist in traditional

mobile networks. Survivability, fault tolerance, dynamic addressing, channel management, collision avoidance, security and mobility management are a few of the key problems that have been the focus of research community in recent years. Several studies revealed that in an ad-hoc network with highly mobile nodes, the routing problem and channel access problem must be addressed together. Studies have also revealed that the lack of fixed access points requires real-time self-organization of the mobile units and dynamic self structuring with intelligent access point selection. Among the many problems addressed, routing and channel access have been the primary focus of the research community, with an extensive amount of work being dedicated to routing in mobile ad-hoc networks. Most routing algorithms reported in recent research literature – either table driven or on-demand routing protocols – assume that the network is stable during the execution of the routing algorithm and also assume fixed access points rather than mobile access points. Also, current research has addressed routing and channel access as two, separate problems. SPARNET architecture is designed with survivability, fault tolerance, dynamic addressing, security and mobility management in mind. The network nodes in SPARNET dynamically organize into clusters and utilize a novel leader election algorithm for cluster gateway election. In this report, the target users (i.e. Army instructors and the soldier-student team) form and move as a cluster, although there can be considerable motion within the cluster. The soldier-students may, or may not, all be in the radio range of the instructor. The network nodes move in clusters and there can be individual motion within the cluster.

The SPARNET network layer allows for the ad-hoc creation and dynamic, intelligent reorganization of a tiered network of highly-mobile sensor nodes. As a dynamic, self-configuring network, countless network topologies are possible. As a testable requirement, however, the network supported five Student nodes and the following topologies at the squad level:

1. Linear topology
2. Star topology
3. Tree with a single root node, one or two branch nodes, and two or three leaf nodes

The network software continued to be researched and developed with the objective of supporting each of the milestone demonstrations called out in the USARIEM SPARNET PWS, incrementally laying the foundation for design-improvements with which to monitor ever-larger groups of Soldiers.

Performance-assessment software was developed to facilitate the capture and storage of performance metrics, as required to support demonstrations and characterization tests. Architectural changes to improve the capability of the network-layer software were advanced. Specific areas under study included: improved probability of link-availability, methodologies for propagating path fitness based on weighted metrics (battery level, number of subscribed nodes, signal-to-noise ratio, etc.) and hop-depth management. The network was modified to enable the TOC to receive all node-specific data-packets directly from the instructor, rather than solely by direct observation of the individual squad-area-network (SAN) radios.

During this period, network processing-time measurements were made. The measurements demonstrated all packets were transmitted and received between the instructor node and the student node as required to complete registration of the student nodes. The network layer was modified to provide the time-of-first- invitation from the instructor and subsequent time-of-first-registration by students. This information is presented by overlaying the data on the map on both the Instructor's mobile device (iPAQ and subsequently the Windows-based Tablet) and the TOC application. This enabled the analysis of the time for first-registration and re-registration processes. Modifications were

made and tested that provided for improved control over experimentation with packet transmission-intervals. The capability was later used to establish and verify proper operation of the currently-used traffic-timing.

Work on the registration architecture was executed. A node will begin registration process with another suitable parent when it receives an energy level of RF AGC=0 from its current parent. This added metric will aid in determining the fitness of a node's current parent. To ensure delivery of stored data packets, retransmit of a data packet (when an acknowledgement (ACK) from the direct parent is not received) has been enabled. It will allow 1 retransmit attempt. The network transmits an ACK between the originating node and its immediate parent. An issue that may arise with this functionality is when a packet is lost during some intermediate hop. Since an ACK is not issued when a packet is received via an indirect child, the subsequent parent down the chain-link will not know that a packet was not received from its grandchild. If we are to enable ACKs for all these hops, the number of packets will double and since current configuration timing is optimized for 5 nodes, collisions may occur. Finer timing granularity to support a higher node-count was envisioned to be advanced in the option years.

Under the currently envisioned evolution, trainees would transmit their 911 messages during their assigned time-slot, but could also be transmitted on a randomized basis during a set-aside interval. The network layer was configured to enable functionalities for the advancement of certain Option Year 1 tasks, such as the formation of multi-squad and multi-instructor network. The design was aimed to form two, separate, instructor-led squads, operating on two separate network identification numbers. Support for bi-directional messaging via the repeater node between the following node types: TOC/student and TOC/instructor, was also perfected. The network layer was modified to update the LCD (liquid crystal display) 911 messages to match the state of the 911 push button of the radio in order to diminish any delay. The previous scheme was updating the LCD display every 30 seconds. Enhancements provided real-time update of the LCD display with the corresponding 911 bi-directional push button and messages.

Additional assessment tools and command-line-interface (CLI) messages were added to the code to aid in validating proper storage and operation of stored messages when a node is off-network, as it relates to node de-registration and subsequent re-registration, packet queuing and buffering. This tool is instrumental in the analyses of the CLI outputs during laboratory and field testing, as well as the examination of the CLI outputs from the demonstration and submission of the corresponding demonstration technical reports. .

#### **4.1 Integration of GPS 1PPS in Network Time Keeping Operation**

A network time-keeping capability was designed, implemented and tested. This feature is calibrated by the GPS signal and, subsequently, sustains node-timing during periods of GPS outage. This provides a period of operation during which the transmission of node- and network-packets will continue, counteracting the effect of intermittent disruption of GPS communication.

To allow finer timer resolution, individual network node time was derived from the 1 pulse-per-second signal available from the on-board GPS module. This allowed network timing synchronization to be achieved. The objective of the time synchronization subsystem was to discipline this clock source to the incoming 1 pulse per second (PPS) GPS signal. The target was to obtain a time reference that provides a highly stable source at the required rate.

## 4.2 New Managed Network Architecture

In order to make the most effective use of the available network capacity, the network-layer design was incrementally advanced to result in an architecture that exhibits a high degree of managed-control that is available through the Tactical Operations Center (TOC). This "managed network" philosophy provides for enhanced performance by providing greater control over system resources.

In the original network architecture, the instructor-node broadcasted an invitation message and nodes replied using an ALOHA scheme, attempting to register on the network. The random nature of ALOHA transmissions resulted in collisions that can slow the process of receiving a time-slot assignment and registering with the network. An improved methodology can be realized by taking advantage of the fact that the radios authorized to be within a squad can be pre-assigned a time-slot by the TOC. With this information available to the instructor's radio, the invitation message can be made to be more information-rich and eliminate collisions during the registration process.

In some cases, improvements made are enabled by features of the SPARNET use-scenarios that distinguish them from many commercial, network specifications. In particular, unlike many published network standards, the SPARNET system has a priori knowledge of all nodes that are assigned. That is, at the TOC, there exists a complete listing of all radios (with associated identification numbers) that are authorized to operate on the system. This means that, during the configuration of an instructor's handheld unit, the roster information required for operation of the instructor's map application will contain the list of trainees, the identification numbers of the radios assigned to the trainees, along with a time-slot assignment from a master list of available time-slot resources.

Under the newly developed network-layer implementation model, the previous invitation message has been replaced with a control message. The control message contains the radio identification-number of each radio within the instructor's squad, along with the time-slot that the radio has been assigned by the TOC. When this message is broadcasted, receiving nodes will immediately discover their time-slot assignment, as well as the radio identification numbers and time-slots assigned to all other radios within the squad. Individual radios will complete their registration and transmission of their first data-packet during their assigned time-slot, not using a randomly-transmitted packet in response to the invitation message.

The new architecture, based on a priori knowledge of radio IDs and time-slots, transforms the registration from a probability-based process to a deterministic process. Further, because nodes register in their own time-slots, registration with candidate parents that have temporally-nearby time-slots and exhibit adequate link-energy can be accomplished more quickly, an important benefit when the validity of a signal-strength assessment rapidly declines with time. In addition to providing pairings of time-slots and radio identification-numbers, the control packet is envisioned to contain squad-specific, network-configuration information. For example, via the managed network model, the payload-length of packets and the hop-depth might be traded against each other to permit larger/smaller payloads or shallower/deeper hop-depths.

Other uses for the ancillary information can include signaling of trainee nodes by either the instructor or the TOC. Trainees who become lost would be reported to the TOC. The TOC operator would be responsible for adding the time-slot/radio-ID of the lost trainee to the authorized squad-member list contained in the handheld of TOC-selected instructors. This information would be added to the broadcasted control message and repeated throughout the individual squad network. If the lost trainee comes sufficiently close to the network, it would register and this information would be passed to the

TOC and, via the TOC, to the trainee's instructor. This functionality was successfully shown in Demonstration 4, where an off-net trainee-node was recovered by a squad to which it had not been previously assigned.

#### 4.2.1 New Network Creation Rules

At startup, the TOC application will initiate the network by sending a roster over the TOC radio that will be used to construct the TOC's control message. The network will be initiated when the TOC radio is powered up. The control message is a list of radio IDs of each radio (TOC, Repeater(s), Instructor and Students). Each radio will be able to infer its slot by its ID position in this list.

- Repeater nodes respond to control messages sent by either the TOC node or other repeater nodes that are not its children by sending their data to that node on the repeater time slot.
- The Instructor responds to control messages sent by either the TOC or any repeater node via sending its data to that node on his time slot.
- Students respond to control messages sent by either the Instructor or any student node that is not in their child node table via sending data to that node on their own time slot.

Each node will maintain a list of potential candidate parents based on which control messages it received in the most recent frame. From these nodes, it will select the "best" parent based on fitness metric that will initially be an R.F. automatic-gain-control value but will become more sophisticated in the near future. "Registering" is accomplished by sending data to that parent. The node is considered to have an active parent and will begin sending control messages on its own slot, before it sends its most recent data message. "Registering" is accomplished when a node decides on a parent based on parameters set forth above. See example below.

```
NODE 7 GUID 6666
[10:22.000] cur parent (0) last seen at RFAGC=0
[10:22.008] parent is now 3, RFAGC = 6
[10:22.015] >>DATA
```

When the potential parent receives a data packet from a node, it will add the node to its "childNodesTable", see below.

```
[10:10.192] Type=1000 104:103
[10:10.198] <<Rx DATA
[10:10.202] >>send ACK, direct child
[10:10.208] Node 4 now added to childNodeTable, degree = 0.
```

If a node fails to receive a data message from a node that is in its child node table for 3 consecutive frames, it will assume that this node is not a child anymore and remove it from the child node table. This means that this node is now eligible to be a parent node if it sees a control message from it.

If a node's current parent metric gets too low (e.g. RFAGC = 0) it will reregister with the best new advertising parent it sees in the most recent frame.

If a node fails to receive four acknowledgements in a row in the absence of other advertising parents, it will assume its current parent is unreliable. It will send a deregistration message to its children and begin broadcasting its data.

### 4.3 Bi-directional Communication

Enabling bi-directional communication between the TOC node and end nodes in the training field was achieved by producing an application programming interface (API). The API lets information be written to be written to the radio via the communication (COM) port. The messaging supports an acknowledgment packet that the TOC receives and parse to determine if the message was received by the student.

The basis for bi-directional communication between the TOC and end node is highlighted below. The basic test scenario was that a bi-directional communication is established when a node initiates a 911 event and the TOC manually acknowledges (ACK) the 911 event. The liquid crystal display (LCD) of the node will initially display a "911=OFF". When a node activates a 911 event, the message on the LCD will change to "911=ON" and the corresponding light emitting diode (LED) on the radio will activate and illuminate red.

Once the TOC receives the 911 message alert from the node, it will transmit an ACK of the 911 event. That signal is sent over the network, is received by the target student node, and that node's display will change/update accordingly. When the node receives the ACK from the TOC, the 911 message displayed on its LCD will change from "911=ON" to "911=ACK". Since the ACK has been received by the node, it will deactivate its 911 message event by once again pressing its 911 push button to disable its 911 state and the red LED on the radio will turn off. The 911 state in the node's data packet will reflect that it has been deactivated.

Even though the 911 push button has been pressed to turn off the 911 state, the message on the student node's LCD will remain in "911=ACK". The 911 state in the data packet will reflect that it is indeed off. When the TOC receives the message that the 911 has been turned off, it will clear the bit corresponding to the radio's slot ID in the control message. This will cause the message on the target student's LCD to go from "911=ACK" to "911=OFF".

To satisfy the requirement per *PWS 4v: demonstrate bi-directional TOC and student node messaging for student nodes separated at initiation of TOC node message event and later reconnected*, the premise activity was the same as above. With the target student node off-line (not connected to the rest of the network) the TOC operator designated the target, and transmitted the signal as per a 911 messaging event. The TOC was aware that the target node was either off-line and/or had not received the message, and continued to attempt to deliver the trigger signal until the target node re-connected to the network. At that point, the target node received the trigger signal and actions highlighted in the previous paragraph were repeated.

### 4.4 Operation of Two Squads and Demonstration of Recovery of Off-net Student

The network layer was configured to enable functionalities for the advancement of Option Year 1 tasks, such as the formation of multi-squad/multi-instructor network and the recovery of an off-network student node. The design was verified via the formation of two, separate, instructor-led squads, operating on two separate network identification numbers, using a common R.F. frequency. One

instructor was registered with the TOC node and the 2<sup>nd</sup> instructor was registered with the repeater node. The repeater node forwarded the 2<sup>nd</sup> instructor and its squad's data packets to the TOC node.

The objective was to optimize the network layer for the advancement of the formation of two instructor-led training squads, operating from a single TOC and auto-configured to use a single, R.F. frequency. In Demonstration 4, due to the limitations on the number of radios, each squad consisted of one instructor and two students. The TOC application/database provided the capability to configure/reassign the individual nodes in the separate training squads to and from the two, independent network identifications (id). This allowed the demonstration of the recovery of an off-network student node in which a student node separated from its originally assigned squad.

As the separated student node deregistered with its squad on network id 2, it began broadcasting its data packet and consequently was considered off-network and potentially "lost". The TOC began a discovery/reassignment activity by listing the "lost" student as a member of the first squad and enabling the missing student to register with the first squad on network id 1, by making and transmitting the necessary reassignment in the system "control" packet. The control packet was communicated to the instructor of the first squad, where the control packet was propagated to all registered nodes in the first squad. As the "lost" student came sufficiently close to the first squad to receive the modified control message, the "lost" node recognized the authorization to join and registered with the first squad, rejoining the network. Using planned future capabilities, the student node would be directed to return to his original squad, where he would (via TOC command) be de-registered from the first squad and permitted to re-register and resume his training activities with his original squad. Alternatively, it could be directed to some other area at the discretion of training personnel.

#### 4.5 Develop Performance-assessment Software

To prepare for requirements set forth in the Performance Work Statement (PWS) and to fulfill successful demonstrations criteria for base year 1, system-performance measurement-utilities and metrics were the subjects of engineering activities. Performance-assessment software was developed to facilitate the capture and storage of performance metrics, as required to support demonstrations and characterization tests. Exemplar metrics that were characterized included: message throughput rate, error rate, dynamic configuration of network topology, and time of registration/re-registration.

Topologically-based features were added and field sizes were optimized to allow for topology information to be displayed in the SPARNET applications, as illustrated in Figure 34. The architecture supports rendering of lines between participants. This will force participant coloring and to support off-network participants to display via TOC Application. In Figure 34, the time of registration to the node's respective parents are listed on the top left hand of the application.

Figure 34 illustrates the need for maps with finer granularity, when zooming in to span short distances on the display. As can be seen, the pixels of the digitized map, while still showing local, geographical features, can become objectionably unclear. The use of map-files with higher resolutions will gracefully resolve this issue. When the display is zoomed out, the granular nature of the current map-file is negligible (see Figure 40).

As shown in Figure 34, a student icon is represented by an isosceles triangle. If green, then the last data packet received was successfully routed through the instructor. If blue, the last packet received was received as a broadcasted/un-routed packet and was not routed through the instructor. The number to

the left of the icon indicates its time slot. The time slot corresponds to the time in which the participant transmits its control and data packets. Slots are integer values. The number to the right of the icon is that participant's parent slot.

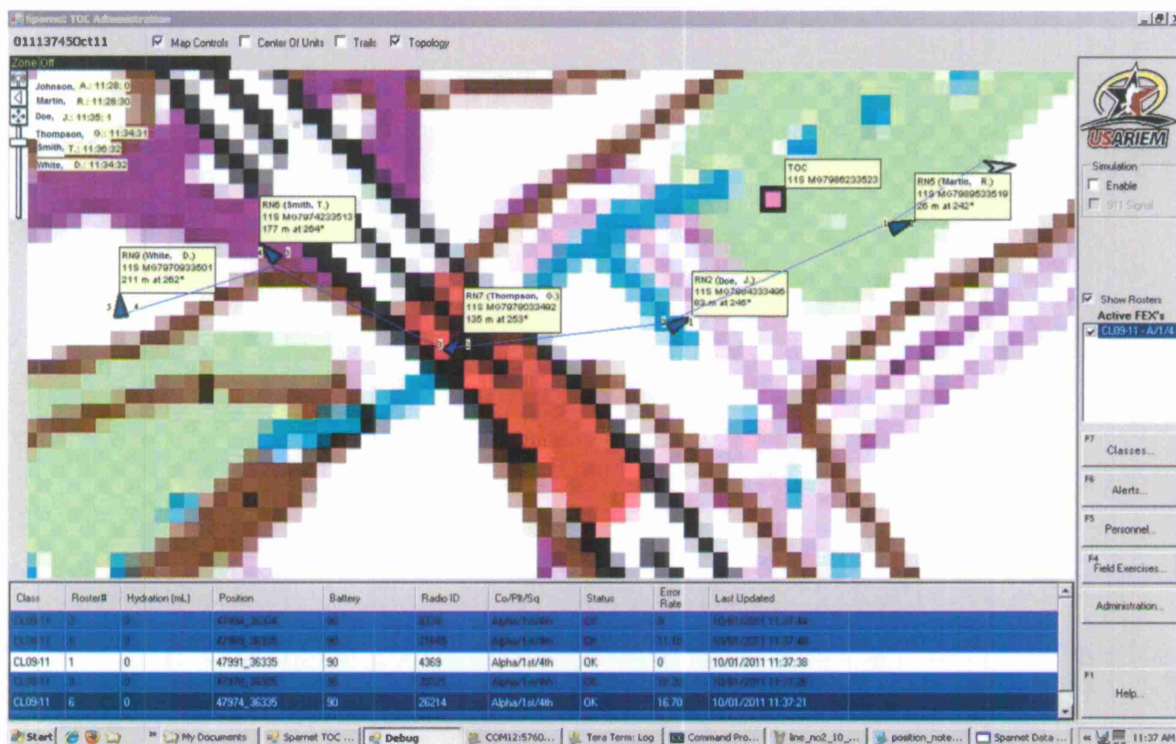

Figure 34. TOC application main screen display

#### 4.5.1 TOC Application/Data Broker Error Rate Calculations

The algorithm that computes packet error rates was reconfigured so that the algorithm checks every thirty-second interval to determine if one packet was received and stored in the TOC database. If no packet was received and stored in the TOC database then this is counted as a packet error.

A function was created to compute the "message error rate". A "message error" is said to have occurred if neither a routed nor broadcast packet from the originating-node is received and stored in the TOC database in any given 30-second interval. This is different from a "packet error" in that the "packet error" checks every 30 second interval, but examines only routed packets (to determine the routed packet error rate), or broadcast/un-routed packets (to determine the un-routed packet error rate.)

##### 4.5.1.1 Message Error Rate

The message throughput rate is a calculation tallied based on the feedback regarding a separate network study. In the study, successful reception of any, routed or un-routed, message received at the head-in was counted as a successful message reception. The assumption is that it does not matter what route the message took to arrive at its destination, what matters is the message successfully arrived at

its intended destination. The message error rate column, as exemplified in Figure 40, represents this assumption. The message error rate is computed the same way the packet error rate is computed. Therefore, as long as the TOC received a packet for any given node (routed or un-routed) within each thirty second interval, then the message error rate is 0%.

#### 4.5.1.2 Error Rate Calculation

The error rates contained in the submitted demonstration technical reports were manually analyzed and computed. This was accomplished by stepping through all the individual TOC Data Broker log and CLI logs of the TOC node, repeater node, instructor node and trainee nodes. For example, in the TOC Data Broker, if there was a missing data packet for a specific node at a specific time, within a 30-second frame, the repeater and the TOC's CLIs were examined to determine at which point in the topology, the data packet failed. At different points in the demonstrations, the repeater and the TOC's respective distances from the nodes in the field were at close proximity, and with the repeater and the TOC's antennas, had the capability to receive or "listen" to almost all of the node's packet transmissions. In analyzing their individual CLIs, one can infer the path, where the breakdown of the link occurred. Once that is accomplished, the log file of the individual node is examined to determine the reason a particular radio's data packet did not arrive at the TOC.

It is also important to understand the context of the "error rate" value in the data set that is displayed on the TOC database/application. It is a measurement of data packets, for each node, that should be received and stored in the TOC database between two specified times. As stated above, in order to determine the exact reason for a particular radio error rate, the log files from all of the radios must be examined.

The error rate is a computed value and is calculated by using the following formula:

$$Er = 1 - [(expected\ packets - received\ packets) / expected\ packets]$$

The expected number of packets received from a radio is an estimated value since it cannot be certain at any given moment exactly how many packets should have been received at the TOC. The expected number of packets received from any given radio is estimated based on the number of times per minute the radio transmits packets, as well as the time at which the radio started transmitting packets. Over time, the error rate can be assumed to be reasonably accurate, assuming the radios were not turned off for some reason since the TOC has no knowledge of the power state of any given radio. The error rate is computed based on the assumption that once a radio has started transmitting, it should continue to transmit in its time slot. In addition, the error rate is based upon a specified time to begin estimating when we expect to start seeing packets.

The calculation displayed on the TOC application is a rolling 10-minute window that computes the error rate. But when a test parameter is specified, it presents the error rate from the beginning of the test to the current time. There are occurrences where the error rate can have a value and revert back to a zero value. This can occur in 2 cases:

**Use Case 1:** No test is running and the displayed routed packet error rate is displaying a 10-minute rolling window. If time is currently 12:09:31, the application would look at every 30-second period between 12:00:00 and 12:09:30 (20 packets - 10 minutes).

## For Official Use Only (FOUO)

*12:00:00 - packet received*  
*12:00:30 - NO PACKET RECEIVED*  
*12:01:00 - 12:09:30 - packet received*

In this case, a packet was not received at 12:00:30 but received every other packet. This means the error rate would be:

$(20 \text{ expected packets} - 19 \text{ received packets}) / (20 \text{ expected packets}) = 1/20 = 5\% \text{ error rate}$   
Let's say for the next 1 minute (2 frames), the TOC received data packets.

*12:10:00 - 12:10:30 - packet received.*

Now the current time is 12:10:31, so the rolling window the application is looking at is 12:01:00 - 12:10:30. In this case, the TOC has received every packet during that time period, and therefore, the error rate would be 0%.

**Use Case 2:** Data collection is specified by starting a test managed through the Administration -> Monitoring tab in the TOC application. The time slot where a packet is not received never rolls out of the window for the error rate calculation since there is a definite start time. However, even though a rolling window is not being used, it is possible for the error rate to rise above zero and then drop to zero again.

*Start of Test at 13:00:00*

*13:00:00 - 13:09:30 - Packets collected (20 frames since the start of the test - 0% error rate)*  
*13:10:00 - Missed a data packet (21 frames since the start of the test - 1/21 packets missed = 4.8% error rate)*  
*13:10:30 - Missed a data packet (22 frames since the start of the test - 2/22 packets missed = 9.1% error rate)*

If the missed packets were due to the node being off network and then the node re-joins after 13:10:30, it starts transmitting its current and store-and-forward data packets.

*13:11:00 - TOC receives current 13:11:00 packet and the 13:10:00 missed packet (23 frames since the start of the test - 1/23 packets missed = 4.3% error rate)*  
*13:11:30 - TOC receives current 13:11:30 packet and the 13:10:30 missed packet (24 frames since the start of the test - 0/24 packets missed = 0% error rate)*

### 4.6 Network Performance Estimates

Foundational field-test operations conducted during the period being reported were based on a topology that consisted of: one TOC node, one repeater-node, one instructor-node and five trainee-nodes. In order to confirm the suitability of the design for extension to a larger, more-complex topology analysis and simulation was conducted.

During the project, modification of the process by which nodes register and form the ad hoc network was changed to a Time Division Multiple Access (TDMA) approach. In TDMA, each radio-node is assigned an exclusive, periodically-occurring time-slot. By extending this approach from the data-communication interval to include the registration interval, the potential for packet-collisions was eliminated.

## For Official Use Only (FOUO)

The formation of a network commences with the transmission of configuration information. This information provides the identification number of each radio within a squad, including that of the instructor, along with a unique time-slot assignment for each radio. Upon reception of this packet, and under the assumption that the on-board Global Positioning System (GPS) receiver has acquired and provided the system time-base, individual radios may initiate data-transmissions.

Verifying the extensibility of the design from supporting a single instructor and five trainees to two instructors, each with ten trainees, begins by calculating the number of unique slots (one for each participating radio-node) required by the new topology. Since there are 25 radio-nodes in the topology under analysis, 25 unique slots are required.

The Spartan design philosophy of the network-layer architecture requires that each slot be sufficiently-long to allow communication over the number of message-hops that are required to deliver an updating-packet to the Tactical Operations Center.

For example, under the scenario wherein the hop-depth within the Squad Area Network is constrained to five hops, the network could configure such that a maximum of five hops would be required to allow an update-packet from the most distant trainee to arrive at the instructor-node. However, to arrive at the TOC-node, an additional three hops would be needed. In total, the duration of the assigned slot-length needs to be sufficient to permit a total of eight hops, plus an initial re-transmission of the configuration information by the originating node, prior to sending its data packet.

The ability to support any given number of hops within a single time-slot is a function of the number of bits in a packet (two bits/symbol) and the symbol rate used by the SAN radio. It is important to note that because the radios are software-defined, with minimal modification it is feasible to gracefully, incrementally increase the symbol rate to at least twice the current rate to support additional message traffic, if necessary. But, for purposes of providing estimated performance based on normal operational cases of star- and linear-topology, the symbol rate employed during the demonstrations is assumed for the analyses and simulations that are reported in this section.

Under the symbol rate and packet structure employed in the field tests, the duration of a packet-transmission was 253.6 milliseconds. So, the slot-time necessary to support a total of nine packet-intervals is 2282 milliseconds. Assuming a once-per-minute update rate, this means that a total of 26 nodes can be supported, with no change other than a simple adjustment to the slot-length parameter.

Simulation scripts were written and run to support analysis of the two-instructor topology called out in the Performance Work Statement. The results provided, below, exclude the delay that can be caused by the time required for the GPS receiver to acquire and make available the system-time that enables the associated radio to transmit. Based on measurements made during field demonstrations, the average amount of time required for GPS acquisition was, approximately, 30 seconds, with 170 seconds being the longest time ever observed, using the integrated GPS antenna.

Under the TDMA protocol unique time-slots are assigned to each radio node. This means that the configuration of separate squad-area networks, where the associated radio-nodes are well within radio-range of each other and operating on a common radio frequency, will occur without interference between radio-nodes. A two-squad topology was successfully demonstrated in Field Demonstration #4 of the project, with both squads within radio range and using a common frequency.

## For Official Use Only (FOUO)

The time required for the network to auto-configure is a function of a variety of factors that can include: topology-type, slot order, update-interval (where "update-interval" (or frame) is the period required for the slot-assignments for all nodes to occur one time) and the distribution of specific time-slots within the frame.

The simulation results provided were derived using the bounding topological cases of the squad-area portion of the overall network that were approved and adopted for the field demonstrations. These are the star-topology, shown in Figure 35, and the five-hop linear-topology, shown as the upper-branch in Figure 36. It was assumed that the repeater network was already formed at the time that the individual radios in a squad are energized. Further, it was assumed that all of the radios in a squad, including the instructor's radio, were simultaneously energized.

A range of packet-error-rates, based on observations made during demonstrations, was used in simulations to provide broader insight into the effect of the link-quality on both network-configuration time and network throughput.

The influence on network-formation of the association of a particular slot-assignment with a particular trainee-radio is not a factor in a star network. In all other network configurations such associations can influence the amount of time required for initial configuration. The reason that the association of time-slots with nodes affects configuration-time is attributable to their order of occurrence within an update-interval (frame).

The network layer operates by partitioning a frame into time-slots. The sequenced-occurrence of time-slots within the frame begins with the TOC, followed by the repeaters, instructor and trainees, in that order. The configuration of the network, following instructor-registration with the repeater-network, begins with the instructor-node transmitting configuration information that was previously obtained from the TOC.

Trainee-nodes that are within range of the instructor receive the transmitted configuration-information. The time-slot that is assigned to the radio-identification number of a receiving trainee-radio is retained by the radio. The radio monitors radio transmissions from other nodes to produce a list of suitable parent-nodes. Following reception of the configuration information, when the time-slot of a radio occurs the radio will transmit its trainee-data to the parent that it elects.

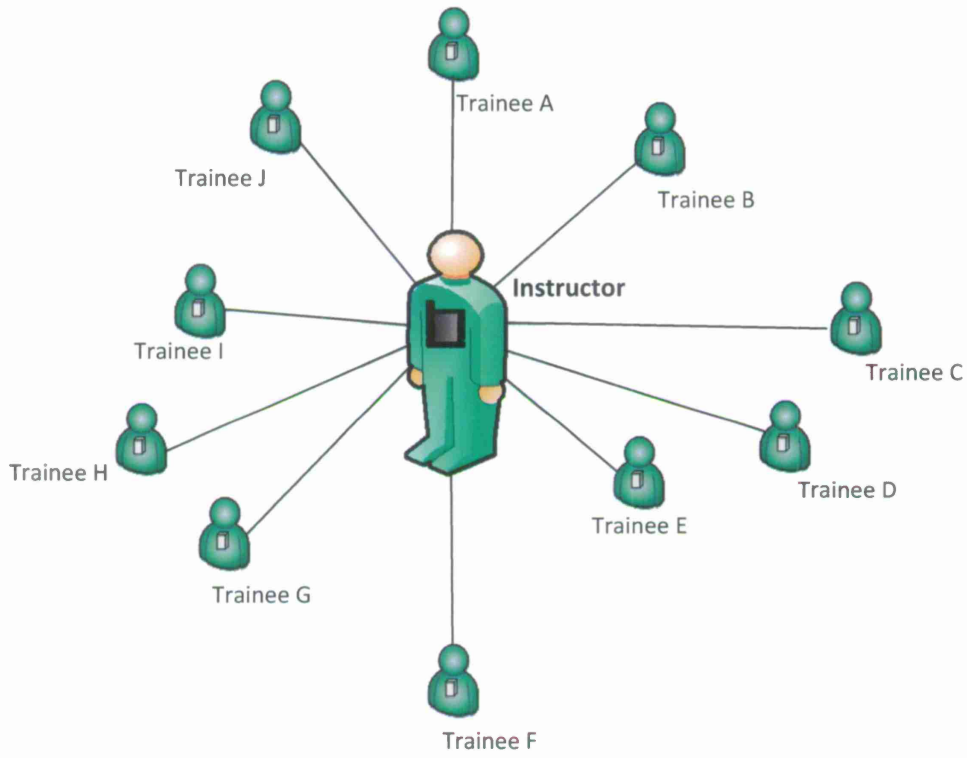

Figure 35. Star-topology with 10 trainee-nodes

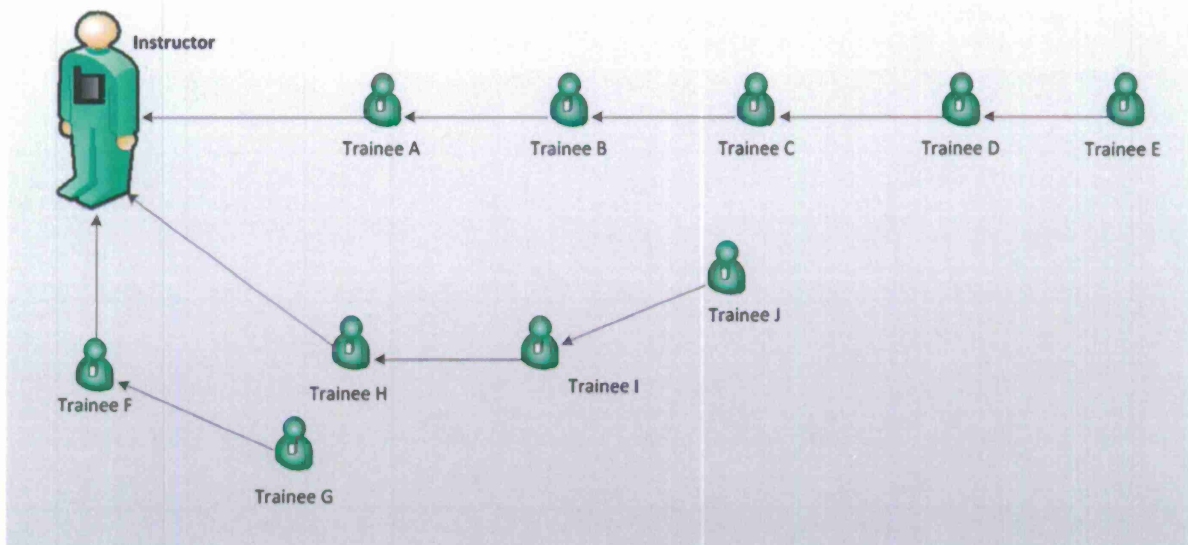

Figure 36. Linear-topology with 5 trainee-nodes

Under ideal conditions, the most suitable parent would be one that has a time-slot that occurs immediately preceding the one assigned to the node that wishes to transmit. Candidate-parents that have a time-slot that is temporally-close, preceding that of the prospective child-node, is assumed to be more reliable than information that was obtained during earlier transmission evaluations.

Figure 37 illustrates an ideal arrangement of nodes for a linear topology to be formed upon start-up. This is because each of the time-slots occurs immediately following the time-slot of the candidate parent. This association of time-slots with node locations enables the fastest possible configuration-time for a linear topology. That is, the entire topology can be formed within one frame (approximately 58 seconds, assuming once-per-minute updates).

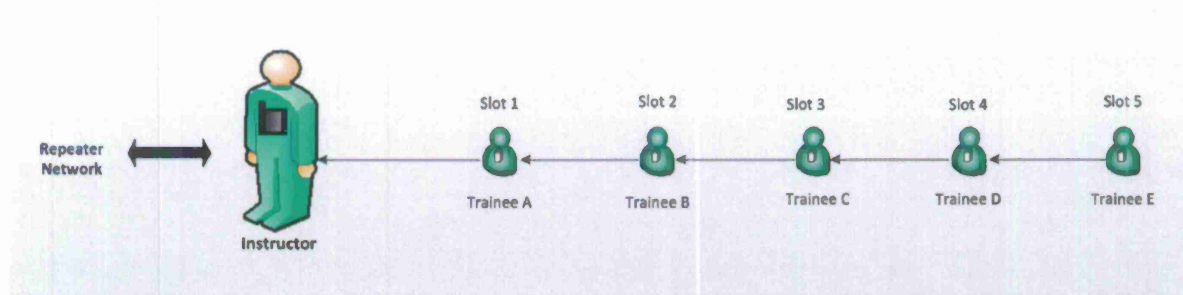

Figure 37. Slot-ordering supporting shortest configuration-time

Under certain scenarios, it can be the case that the most suitable parent-node, in terms of signal-strength, may have a time-slot that occurs after the slot that has been assigned to a prospective child-node. This can slow the registration process, but has no subsequent effect on the immediate relay and arrival at the TOC of post-registration packet-traffic.

The most extreme case would be in a linear topology where the time-slots occur in descending order, moving away from the instructor, are adjacent and located at the end of the frame, and the trainee-nodes are out-of-range of any nodes except their immediate neighbors. The latter condition would delay discovery by each node of its time-slot assignment. Such a topological configuration is illustrated in Figure 38.

Assuming a 25-slot frame-partition, in the descending-time-slot-order scenario the trainee-node closest to the instructor, Trainee E, could register within the first frame, typical of trainee-registration under a star-topology. Thereafter, registration by Trainee D would be delayed by one minute minus the number of slots between the beginning of its time-slot and the time-slot of Trainee E. Similarly, registration by the third trainee-node, Trainee C, would occur one minute minus the interval between its slot and the slot of Trainee D.

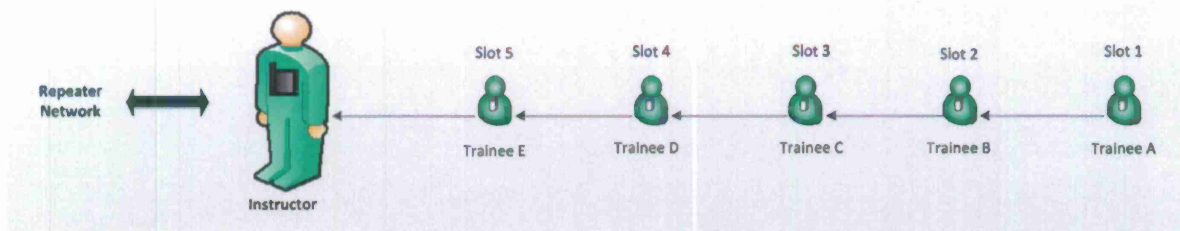

Figure 38. Slot-ordering imposing longest configuration-time

Assuming that the five slots of Figure 38 were adjacent and occurred at the end of a one-minute update-interval, and that each node successfully registered on its first attempt, the minimum amount of time required for the linear topology with descending slot-order to form would be, approximately, 4.7 minutes, or 2.35 minutes if 30-second updates were employed. (Note, this worst-case slot-arrangement was assumed for the network simulation results reported in Table 2.)

It should be noted that the probability of having a descending order with each node able only to communicate with immediate neighbors upon network start-up would be small. The registration and network-configuration process is certainly achievable, but doesn't represent a practically-occurring configuration-initiation use-scenario, if for no other reason than the channel-impairments (terrain-blocking, extended range) that would have to be present. For example, it is unlikely that an instructor would separate trainees by ranges of 1000 meters and only then issue a command to energize all radio-nodes.

Simulation was used to obtain estimates of the number of frames required to form the bounding cases of star and linear topologies. The squad-area network modeled with the star-topology included one instructor and 10 trainee-nodes. The linear-topology consisted of one instructor and five trainee-nodes, representing the maximum hop-depth case.

Two cases of the linear topology were examined. In one, the time-slots were associated to support the shortest configuration-time, as suggested in Figure 37. In the other, the time-slots were associated to impose the longest configuration-time, using an ordering such as that of Figure 38. The results for the star and linear topologies are provided in Table 1 through Table 3, below.

Each row of each table contains the results for 10,000 network initial-configuration trials. The columns contain the number of times that the associated number of frames (shown at the top of the columns) were required to achieve full squad-registration, under the overall packet-error-rate shown in the left-most column.

For example, in Table 1, for an overall throughput of 90% (10% error rate) observed at the TOC, in 6285 of the 10,000 trials the entire network of 10 trainees, arranged in a star, registered to form the squad-area-network within the first frame (update-interval). Another 3390 of the 10,000 nodes registered within the second frame. The length of a frame is dependent on how a network is operated. While one-minute is often used as a reference, the actual length of a frame can be under the control of the network operator and depends on factors such as the permitted hop-depth, total number of nodes being operated and the number of available operating frequencies.

**Table 1. Squad-subscription completion-frame (star-topology, 10 trainees)**

Pkt Err	Frame Number								
Rate (%)	1	2	3	4	5	6	7	8	9
10	6285	3390	303	21	1	0	0	0	0
8	6936	2879	174	10	1	0	0	0	0
6	7547	2343	107	3	0	0	0	0	0
4	8282	1671	47	0	0	0	0	0	0
2	9183	807	9	1	0	0	0	0	0

Table 2 shows the results obtained for the case of a linear topology with ascending slot-time indices, such as is shown in Figure 37. As can be seen by examining these results, complete network-formation is possible within the first frame-interval. This reflects the fact that the time-slot of each child-node's candidate parent occurs prior to the child-node's time-slot. So, there is no additional delay imposed by having to wait until the next frame to respond to the transmission observed from the candidate parent-node.

**Table 2. Squad-subscription completion-frame (linear-topology, ascending slot-times)**

Pkt Err	Frame Number								
Rate (%)	1	2	3	4	5	6	7	8	9
10	7732	1983	253	30	1	1	0	0	0
8	8138	1650	193	18	1	0	0	0	0
6	8632	1256	105	5	2	0	0	0	0
4	9127	822	50	1	0	0	0	0	0
2	9526	456	16	2	0	0	0	0	0

The results of Table 3 show the anticipated delay in commencement of network formation that is caused by the fact that the time-slots of the parent nodes occur after the time-slots of the associated child nodes. When a child node first hears a transmission from the prospective parent, it cannot respond until the next time that the child's own time-slot occurs. Depending on where the child's slot occurs within a frame, relative to the parent's time-slot, that time can be up to one full minute, minus one slot-time. For the purposes of the bounding-case simulated and reported in Table 3, the absolute worst-case scenario was modeled. That is, the last five time-slots in a frame-interval were used in the model. Note that the numbers obtained for the subscription-performance are similar to those of the ascending-time-slot-index case (Table 2) but are delayed in time by five frames, as expected for the descending-time-slot-index case.

**Table 3. Squad-subscription completion-frame (linear-topology, descending slot-times)**

Pkt Err	Frame Number								
Rate (%)	4	5	6	7	8	9	10	11	12
10	0	7764	1940	261	32	3	0	0	0
8	0	8179	1629	176	12	4	0	0	0
6	0	8615	1253	122	9	1	0	0	0
4	0	9076	867	55	2	0	0	0	0
2	0	9533	462	5	0	0	0	0	0

Table 4 shows the configuration results for a five trainees, registering as a star, the topology with no dependence on the registration status of other trainee nodes.

**Table 4. Squad-subscription completion-frame (star-topology, five trainees)**

Pkt Err Rate (%)	Frame Number								
	1	2	3	4	5	6	7	8	9
10	8108	1810	81	1	0	0	0	0	0
8	8485	1467	48	0	0	0	0	0	0
6	8815	1150	34	1	0	0	0	0	0
4	9247	741	12	0	0	0	0	0	0
2	9631	364	5	0	0	0	0	0	0

Comparison of the simulation results shows that, with all other things being equal, a linear subnet of five-trainees with descending slot-assignments would produce the dominant delay in forming a squad-area-network topology. That is, if five nodes form a linear-topology, while the remaining five form a star or shorter, branched sub-networks, the five-node linear-element is most likely to be the dominant factor in determining the overall time required for the entire 10-trainee network to form. Comparison of Table 1 and Table 4 provides insight into the effect the number of trainees, registering in a star, has on the overall time required for initial configuration.

With regard to network throughput, the addition of nodes that increase the number of hops required to span the origin-to-destination space will have the net effect of reducing the successful packet-reception rate. That is, operating individual squads with additional trainees, while maintaining the hop depth to be the same as used in prior work (five-hops within the squad) will not affect the characteristic throughput of the system. This is because the network employs TDMA protocol, making the statistics of message throughput for one originating-node independent other nodes. However, with all other things being held equal, the incorporation of additional repeaters in a way that introduces additional hops to the network would have the effect of reducing the successful packet-reception rate for any given squad.

So, under the scenario where the network is expanded to take the form of two, ten-trainee squads, each squad communicating via a unique repeater that links directly to the TOC (repeaters form a star-topology with the TOC) the throughput performance would be similar that documented during the final demonstration. Only the case wherein the two repeaters form a linear connection to the TOC will cause a reduction in the throughput. Estimates of the effect are provided in Table 5.

**Table 5. Estimated Effect on Network Throughput by Additional Repeater in Linear Repeater Topology**

<i>Successful Packet-reception Rate</i>				
<i>Baseline</i>	<i>Estimated ( at Instructor)</i>		<i>Estimated (at TOC)</i>	
<i>(%)</i>	<i>Star</i>	<i>Linear</i>	<i>Star</i>	<i>Linear</i>
90	0.9851	0.9275	0.9416	0.8866
92	0.9882	0.9422	0.9535	0.9091
94	0.9912	0.9568	0.9653	0.9317
96	0.9942	0.9713	0.9769	0.9544
98	0.9971	0.9857	0.9885	0.9772

## For Official Use Only (FOUO)

In Table 5, the column titled "Baseline" represents the successful packet-reception rate from which the individual, single-link statistics were calculated. The entries of the remaining columns show the estimates of successful packet-reception at the instructor-node and TOC-node, under the various cases of single-link performance. The baseline values are exemplar of those observed in both field and laboratory network testing.

In addition to the time required to initially form a network and the subsequent probability of successful packet-reception, estimated operational-life is a key system-characteristic. Estimation of operational-life can begin by noting that trainee- and instructor-radio battery-capacity is significantly less than that of a repeater-node or the TOC-node. That is, the squad-radio is the central element of interest in estimating network operational-life.

In order to provide a foundation for determining required estimates, a range of single-link and five-trainee network-testing was executed to determine operational-life characteristics, as currently configured. This information was used to generate the estimates that follow.

With the software operating as it is currently configured, the network operational-life in actual field tests has been observed to be in excess of three hours when the radios are operated exclusively using high-power transmissions and in excess of 3 hours 45 minutes when operated exclusively using low-power transmissions. Recently-conducted single-link and five-trainee network-testing, aimed at precisely determining operational-life, confirmed operations lasting 3 hours 12 minutes (high-power mode) and 4 hours (low-power mode).

For purposes of estimating operational-life, it is useful to consider an exemplar network consisting of one TOC-node, one repeater-node, one instructor-node and five trainee-nodes. Such a network requires eight time-slots per update-interval.

It is important to note that, across all possible network architectures the instructor-node is the most heavily-burdened, in terms of transmission and reception activity. The amount of drain that this activity places on the battery is a function of both traffic-volume and the transmission power-level.

Other methods for increasing the operational life of the radios, while permitting continuous operation, were planned for Option Year 1. Because a significant amount of the power consumed by the radio is attributable to the continuous computational load imposed by the Blackfin processor, large reductions in power consumption can be accomplished by leveraging dynamic power-management that provides for control of processing-frequencies and core voltage-levels. In addition, five, standby power-modes are available for use.

The use of two, dual-core processors on the SPARNET digital board offers the opportunity to partition the software into multiple cores. This, in turn, allows the processing speed and core voltage of any given core to be reduced. Power consumption is reduced linearly with reductions in clock frequency and as the square of reductions in core voltage.

Initial analysis shows that achieving a reduction in overall power consumption to a level that is between one-quarter and one-third of the current consumption can be accomplished in the design by straightforward means such as code-partitioning to enable reduction in processing speed, power-management of peripheral components that are not currently put in standby when feasible and use of processor standby-modes.

## For Official Use Only (FOUO)

For example, currently, all circuits operate continuously. However, the actual requirement is only that selected circuits be operated during specific intervals within the time-slots that are assigned to the TOC, instructor and other trainee-nodes that are within the same squad. Even in these cases, radios that have relayed a packet may be immediately placed in standby mode, once the transmission has taken place. The savings in power that results from this approach is topology-specific but is significant.

Consider the network set forth for analysis in 5b, on page 10 of the PWS. This is a network consisting of one TOC-node, one repeater-node, one instructor-node and five trainee-nodes. First of all, assuming a partitioning that permitted support for 26 nodes, but in which only 8 were supported, the instructor-node could be placed in standby for at least 17 time-slots, assuming the time for one additional slot was lost to activity related to enabling/disabling standby-mode operation. The radio would effectively be turned off for 65% of the update-interval, increasing its operational life by, approximately, 2.9 times. Based on the measured values reported above, this would result in an operational-life of 9 hours 16 minutes in high-power mode and 12 hours when operating in low-power mode.

As previously described, additional savings can be attained by making straightforward refinements to the network layer software such that a radio will go into standby-mode immediately after forwarding a packet.

For example, in using a partitioning for 26 radios, but operating with one repeater, five trainees, and depending on when the packet to be relayed occurs within a time-slot, an instructor-radio could be turned off for between 22% (5-trainee linear topology) and 67% (star-topology) of the packet interval. The actual amount of time that the radio could be placed in standby is primarily a function time-slot-length, which is a function of factors such as: packet-length, update-rate, squad-topology and maximum hop-depth from the repeater. The amount of time required to exercise power-management features is on the order of milliseconds and can be ignored for purposes of the estimates being discussed, here.

It is important to note that the operational mode set forth in the preceding paragraph is relevant to operation with any number of supportable trainee-radios. That is, the same reduction in power consumption can be realized across larger squads.

In the case of a five-trainee squad, an average reduction of 40% across the trainee-node slot-times would result in an additional reduction in power of 7.7%, raising the previously-estimated operational-life values for the high-power and low-power cases to 11 hours 53 minutes and 14 hours 51 minutes, respectively. Dynamic power control would result in an aggregate operational-life falling between these two limits.

For ease of explanation, the analysis has assumed a conservative case in which partitioning to support 26 nodes is done using slots of equal length. In actual practice, some slots will be somewhat shorter than those used for the squad-area radios.

For example, the TOC-node is not involved in lengthy relay activities. So, the remaining time that would otherwise have been allocated to the TOC under a uniform-slot-length model can be used for other purposes or aggregated with similar savings from repeaters to enable an additional slot or otherwise contribute to minimizing power-consumption.

#### **4.7 Modification of SAN Network Software for Repeater-node Application**

To facilitate training over a more expansive geographical area, a network of stationary repeater nodes can be placed to create a lengthened communications backbone to relay participant node-information as presented by the various instructor nodes. These repeater nodes are capable of transmitting over greater distances and are not constrained by the lower power requirements of the wearable radios. For all but the smallest training scenarios, participant information is relayed from the instructor to the TOC via at least one Repeater node. This was the premise executed in Demonstration 4 performed on February 02, 2012.

Due to the volume of data that must be transmitted over this backbone, the timeliness of the student data updates and the transmit range of the repeater radio(s); the repeater network can be configured to use a different operating frequency than the instructor gateway network.

Data intervals on the repeater network are longer than data intervals on the individual gateway networks since there are likely fewer repeater nodes and each is responsible for relaying much larger amounts of data. In the same way as DATA packets in the squad-area networks multi-hop during the data interval of the terminating node, the data packets relayed from each child gateway node are concatenated, transmitted and retransmitted by the Repeater network during the data interval of the repeater node for which those gateways are children.

The repeater network software was developed using the squad-area software as a foundation. Like the individual gateway networks, the repeater network is self-configuring. The TOC node will act as the gateway of the repeater network and be responsible for sending invitations to both other repeater nodes and gateway nodes. In this network, gateway nodes do not rebroadcast this invitation – only repeater nodes can extend invitations to register on the repeater network. Registration on the repeater network follows the same protocols that trainee end nodes use to register with the squad-area gateway network. Additionally, the design is envisioned to allow the TOC operator to interrogate the repeater backbone for information on student-nodes. In cases where a student-node has unexpectedly fallen off of the squad-area network, the Instructor may request that the TOC locate and report the student-node position.

#### **4.8 Store and Forward Capability**

For the squad-area network, a store-and-forward capability was introduced to satisfy the PWS requirement set forth to be executed in Demonstrations 2-4. In the event that a student node exceeds the radio range of the Ranger Instructor's gateway node, and for some defined period of time is out of radio contact (as indicated by a failure to receive data acknowledgement packets), the student's SAN radio will locally store all pertinent sensor data for the absence period and then forward this to the Gateway node upon resumption of communication and registration back in to the network.

If and when a node receives four network acknowledgement (ACK) failures or receives a deregistration packet from its parent, the store-and-forward functionality will commence. It will begin storing its data packet in a buffer that will increment and store additional packets, as long as the node is off-network or unregistered. Once the node registers with a suitable parent, it will begin transmitting its current data packet followed by the transmission of a store-and forward packet. It will continue in this mode until all the store-and-forward packets in its queue have been transmitted. To ensure delivery of stored data packets, retransmission of a data packet (when an acknowledgement (ACK) from the direct parent was not received) was enabled. It allows one retransmit attempt. The network transmits an ACK between

the originating node and its immediate parent. An issue that may arise with this functionality is when a packet is lost during some intermediate hop. Since an ACK is not issued when a packet is received via an indirect child, the subsequent parent down the link-chain will not know that a packet was not received from its grandchild. If we are to enable ACKs for all these hops, the number of packets will double and since current configuration timing is optimized for five nodes, collisions may occur. Finer timing granularity to support a higher node-count can be advanced. The detailed operation of such network features are application-specific and can be conveniently programmed to best support individual use-scenarios.

The SPARNET network-layer architecture facilitates expedited re-registration of child-nodes via a "de-registration" message that is immediately transmitted by the parent-node, when it becomes separated from the network and is no longer a viable communication path for message-traffic from its dependent nodes (children, grandchildren...). The de-registration message causes all of the parent-node's dependent-nodes to immediately abandon transmissions to their respective, former parents, seek new parents and, where appropriate, commence storage of packets for subsequent forwarding upon re-registration. This design reduces network complexity, conserves battery power and eliminates unnecessary spectral activity.

From the perspective of timely re-registration and data-transfer, this design is more efficient under the unique operational-requirements and constraints of the SPARNET system. Accordingly, subnet operation is intentionally not supported by the SPARNET network-layer and was not demonstrated. However, the independent separation and independent rejoining of nodes is consistent with the more appropriate model and was demonstrated for cases in which nodes that have rejoined the network and are forwarding data will operate as a parent- (branch) and/or a child-node (leaf).

In order to join or rejoin the network, a node must connect to a parent node. This means that a separated node will always, initially, rejoin as a child (leaf) node. After joining the network, it is eligible to act as a parent to other nodes. The requirement set forth in PWS 2e was demonstrated by simultaneously separating two nodes for a period of 10 minutes and then causing them to sequentially rejoin the network. The first to rejoin will enter as a leaf. The second to rejoin will be caused to rejoin with the first that rejoined, becoming its child and transforming it to a parent (branch-node).

The principle of store-and-forward functionality is highlighted below.

- Each student maintains a circular buffer of the last 30 minutes worth of DATA messages.
- In the event of a re-registration, the current behavior is to assume that the node has been off-network for some time, and will begin sending all stored DATA messages in the store-and-forward queue.
- These messages are sent one per frame in the second half of the student's time slot, following the most recent update.
- Parent Node Table
  - Each student will maintain a list of all candidate parent nodes based on which control message it receives. Filtered RSSI values for each of these candidate parents will be maintained, so that they can be compared with the filtered value of the current parent.

For Official Use Only (FOUO)

- DEREGISTRATION Packets
  - DEREGISTRATION packets are used in two cases:
    - If a student discovers a new candidate parent with a better fitness metric than its current parent, it will send a DEREGISTRATION message to its current parent while the link is still available. This will cause the parent to immediately remove the child from its Child Node Table, rather than deleting it after a timeout.
    - If a student discovers its current parent is unreliable and no new parent is available it will send a DEREGISTRATION message to all of its children. This will signal them to acquire a new parent whenever possible.

Future enhancements may include:

- Parent Fitness
  - Combined metrics for parent node fitness will be evaluated, which may include network degree (i.e. distance from instructor), bottlenecks (i.e. the maximum number of child nodes supported or minimum battery level reported by any direct or indirect parent en route to the Instructor) and signal strength.
- Smarter store-and-forward
  - Through the use of deregistration packets, we should have more confidence that a packet sent to our parent and acknowledged was routed to the Instructor. These packets will not need to be maintained in the store-and-forward database.

A packet visualization feature was also integrated for the display of received routed, un-routed and broadcast packets for any particular node, as represented in Figure 39.

Received	Collected	Parent	Latitude	Longitude	Heart Rate	Routed Flag
15:25:07	15:25:08	2	N 32.82783	W 117.230118	0	U
15:25:07	15:25:08	2	N 32.82783	W 117.230118	0	R
15:24:38	15:24:38	2	N 32.8278366	W 117.230141	0	R
15:24:37	15:24:38	2	N 32.8278366	W 117.230141	0	U
15:24:08	15:24:08	2	N 32.8278716	W 117.230163	0	R
15:24:08	15:24:08	2	N 32.8278716	W 117.230163	0	U
15:23:38	15:23:38	2	N 32.82786	W 117.230171	0	U
15:23:38	15:23:38	2	N 32.82786	W 117.230171	0	R
15:23:08	15:23:08	2	N 32.827845	W 117.230171	0	R
15:23:07	15:23:08	2	N 32.827845	W 117.230171	0	U
15:22:38	15:22:38	2	N 32.82787	W 117.230165	0	U
15:22:38	15:22:38	2	N 32.82787	W 117.230165	0	R
15:22:08	15:22:08	2	N 32.8278533	W 117.230158	0	U

Figure 39. Routed, un-routed and broadcast packet visualization

## 5 Application Research and Development

The TOC and Instructor handheld software applications were enhanced and adapted to support an increasing number of Soldiers and training venues. Work to eliminate the use of random transmissions during network-formation was advanced. This was part of the foundational work executed to increase the capabilities of the TOC in managing the use of the communication resources and overall network.

A solid base of requirements was established that defined the detailed functionality needed to field the TOC Workstation application. Plotting of TOC position based on the geo-location of the TOC-node repeater and administration/configuration capabilities were researched and developed. TOC Workstation software modifications were completed to support store and forward and the display of packets collected when a node is off the network. This also involved modifications to the Data Broker software and underlying database code. TOC Workstation software modifications in preparation for the four demonstrations set forth for base year 1 were executed.

The instructor's handheld application was migrated from the personal digital assistant (PDA) and in to the Microsoft Windows Tablet platform. Handheld speech functionality was incorporated and available for Demonstration 4.

Improvements to map rendering was executed. An issue that was discovered during field testing in preparation for the August 2010 demonstration, where the instructor and student icons experienced rendering issue when zooming in/out on the map. The collapse/expansion of the map was causing the locations of the icons to move. Through rigorous testing, the issue was found and corrected on the SparnetMapCreator and patches were applied to the mapping functionality and to the mapping applications of the TOC and instructor's mobile device software.

### 5.1 Icons Jumping in Map Application and GPS Acquisition Time

The root cause of icons occasionally, temporarily jumping from the appropriate map location was investigated. A conference call between Elintrix engineers and the GPS module manufacturer, Trimble, was conducted. The conference call provided valuable insights to the GPS module and the proprietary and non-proprietary protocols that are available for the GPS receiver. The principal issue in this behavior involves the strength of the received signal which, in large part, is dependent on the antenna gain. A larger, or external, GPS antenna (which the current design supports) may be advisable.

### 5.2 TOC Application/Data Broker

Work to perfect certain various functional elements was performed on the TOC application in preparation for the demonstrations. Enhancements were executed to enable all four demonstrations of functional requirements, such as bi-directional communication between the TOC and nodes in the training field, reporting and visualization of heart rate data of trainee nodes, importing and exporting capabilities, and advancement of administrative configurations. User interface for the display of the "message error rate" calculation was integrated in the main display and Monitoring tab of the TOC application.

The capability for the TOC application to prepare for formation of the network by sending a roster to the TOC radio that is used to construct the TOC control message and transmit it over the air, was completed, integrated and tested. As previously stated, the control message is a list of radio IDs of each radio (TOC, Repeater(s), Instructor and Students), where each radio will be able to infer its slot by its ID position in this list. This work enabled the ability for the TOC radio/application to program radio-slot assignments on the field. The capability to add a repeater node to the exercise was also finished. Modification to the TOC Workstation software to support collection, storage, and geographic display- update of the TOC's geographic location was completed.

Modification in the error rate calculations such that "disabled" radios are not included in the error rate calculation was accomplished. An equipment list to facilitate the tracking of the Zephyr BioHarness 3 heart rate modules was finalized. Various enhancements were executed to enable Demonstration 4 functional requirements, including the capability to import hardware information. Modifications were executed to allow the TOC application to transmit an acknowledgement (ACK) of 911 alerts to individual radios, to demonstrate bi-directional communication between the TOC and student node and between the TOC and instructor node. The ability for the TOC application to re-assign radios to any desired slot or network id's, allowing any radio to be re-assigned to any instructor or squad, was added. A bug that affected the correct coloring of icons based on the alert status or conditions was fixed. Other bug fixes were applied to the TOC application/database, correcting initialization issues concerning the transmission of the 911 acknowledgement to the student node, as well as expanding the context menu in the application map-control to provide ample access to the boundary box for the icons on the map.

The map control was updated to display a repeater node icon on the TOC/Handheld application, as well as an updated TOC icon. An interface was implemented to send outbound messages to the map control in support of bi-directional communication. A ruler function was integrated in the map control for both the TOC and instructor's handheld applications. This function will allow the user of the application to click and drag between 2 points on the map to acquire the distance, in meters. Rendering of the TOC and repeater icons were augmented to allow the topology lines to emanate from the TOC to the repeater and from the repeater the instructor. This will demonstrate network self-configuration with the TOC as a root and the repeater as a branch. Other enhancements to the map control include:

- zoom in/out
- focus on participant or student by roster number
- show/hide labels
- switch between views and close the application

### **5.3 Improved Administration and Configuration Capabilities**

Under this task, the TOC user's ability to set preferences such as passwords and display characteristics, security administration capability, processing and storage of routed and un-routed packets, processing and storage of additional packet elements, management, monitoring and visualization of packet error rates, as well as management, analysis and visualization of data was advanced. Enhancements include:

- Implemented features relating to management, visualization, and analysis of packet error data.
- Implemented User security administration capabilities.
- Implemented time synchronization of TOC Workstation system clock with connected GPS.
- Implemented security administration capability.

- Incorporated query of TOC GPS to retrieve the time and position of the GPS attached to the TOC workstation.
- Synchronization of the TOC Workstation system clock with the attached GPS time.
- Incorporated processing and storage of routed and un-routed packets.
- Incorporated processing and storage of additional packet data elements (slot ID, parent slot ID, and parent registration time).
- Management, monitoring, and visualization of packet error rates.

### 5.3.1 TOC Application Main Display

The TOC main display screen is presented to the user when the TOC Workstation software starts, as illustrated in Figure 40. It provides the user the ability to monitor any and all exercises currently in progress. It is used by the coordinating authority of the training operation and is used to monitor the movement and status of all squads of trainees and their instructors and repeaters. The TOC Application runs on a laptop PC that is physically connected to either the root node of the Repeater Network or to the Ranger Instructor's SPARNET radio for single-squad training scenarios.

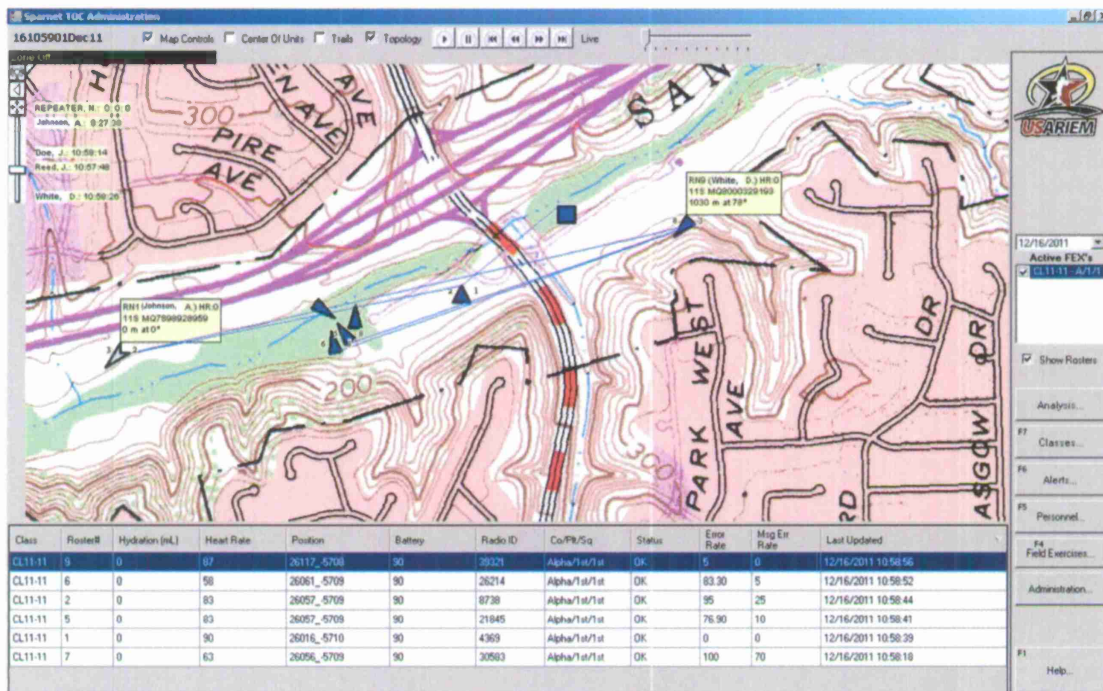
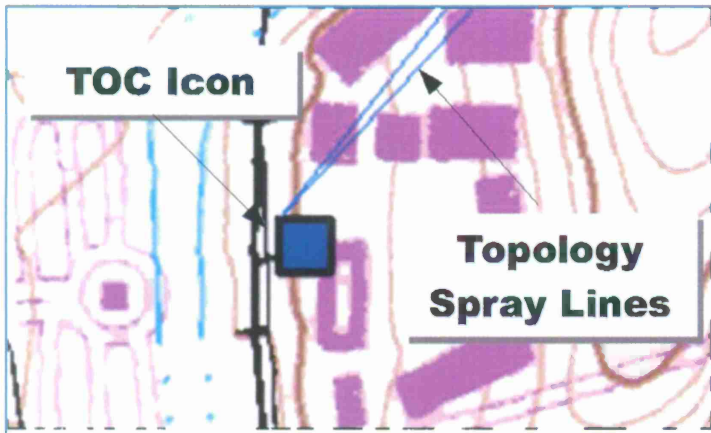

Figure 40. TOC Application Main Display

Below is the legend describing the TOC Software's map icons and coloring scheme.



**TOC Icon** - The TOC icon is represented as a blue square. The icon always remains blue and is positioned on the map based on the position collected from the TOC radio's GPS.

**Topology Spray Lines** – The lines radiating from the TOC connect with other instructor or repeater icons.

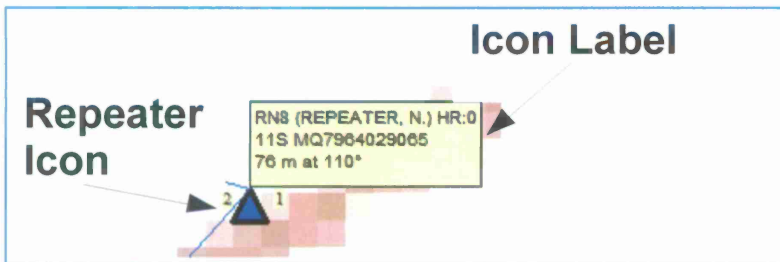

**Repeater Icon** – The repeater icon is represented as a blue equilateral triangle. The icon is always blue and is positioned on the map based on the position collected from the Repeater radio's GPS.

**Icon Label** – When left-clicked on any icon, it will display a tool tip label that displays the roster number, the name of the participant, the heart rate, the MGRS geo-positional data, the distance in meters from the instructor, and the bearing to the instructor. In the case of the repeater, there is an arbitrary roster number assigned for purposes of demonstration and testing, but this is not required.

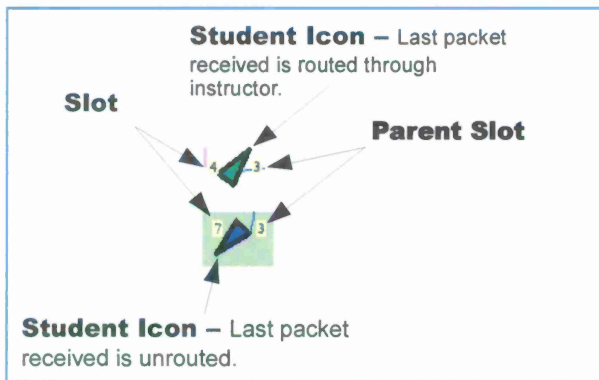

**Student Icon** – The student icon is represented by an isosceles triangle. If green, then the last data packet received was successfully routed through the instructor. If blue, the last packet received was received as a broadcasted/un-routed packet and was not routed through the instructor. The number to the left of the icon indicates the time slot in which the participant transmits data. Slots are integer values. The number to the right of the icon is that participant's parent slot.

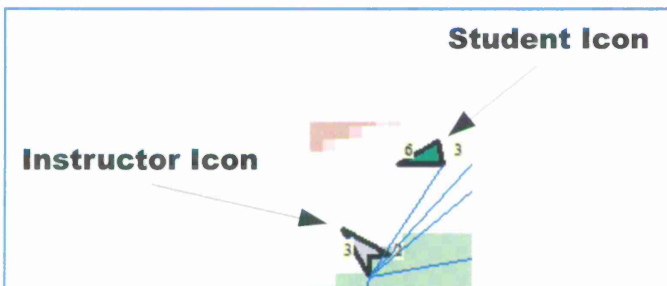

**Instructor Icon** – The instructor icon is represented by a gray colored arrow shaped icon.

## For Official Use Only (FOUO)

Alerting thresholds may be configured by the TOC Application operator such that when a warning threshold or critical threshold is exceeded, the operator is notified by the icon associated with the alert changing colors. Thresholds that may be set include:

1. When a student is more than a specified distance from their instructor.
2. When a participant (student/instructor) has not moved for more than a specified period of time. (Note a lack of movement is defined as no deviation in geographic position of more than 10 meters.)
3. When a participant has not received any routed packets for more than a specified period of time.

Both “warning” levels and “critical” alerting thresholds may be set. For example, the operator may want to know when any student is more than 100 meters from their instructor. This may be set up as a warning threshold. The operator may also want to set a critical threshold be set so they are notified when any student is more than 700 meters from their instructor. If the student strays to more than 100 meters from their instructor then a warning alert is fired resulting in icons changing to a yellow color. If the students strays more than 700 meters, then a critical alert is fired resulting in icons changing to a red color.

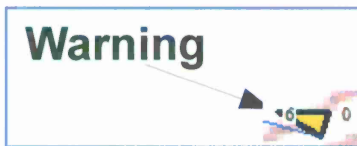

A yellow icon indicates a warning threshold has been exceeded.



A red icon indicates an alerting critical threshold has been exceeded. It may also indicate that a participant has activated their 911 emergency push button.

### TOC Application Roster Listing

Class	Roster#	Hydration (mL)	Heart Rate	Position	Battery	Radio ID	Co./Plt/Sq	Status	Pkt Rec Rate	Msg Rec Rate	Last Updated
Class 3	9	0	12	25365_-5722	90	21845	Alpha/1st/1st	OK	90	90	02/01/2012 13:24:26
Class 3	6	0	0	25959_-5721	90	26214	Alpha/1st/1st	OK	90	90	02/01/2012 13:24:22

The TOC Application’s roster listing is displayed on the TOC Application’s main page and contains the following data elements for each exercise participant:

- Class – The class number
- Roster #: The roster number
- Roster list displays computed/estimated error rate data for each radio.
- Hydration – Fluid intake in mL. Currently displays a value of 0 as the exact implementation of this feature is to be determined.

## For Official Use Only (FOUO)

- Heart Rate – Displays the heart rate captured. A value of "12" is displayed as a default value if no heart rate is captured.
- Position – The geographic position in MGRS format.
- Battery – The battery level. Currently displays a value of "90" as the exact implementation of this feature is to be determined.
- Radio ID – The unique ID of the radio assigned to the exercise participant.
- Co/Pl/Sq – The company/platoon/squad of the exercise participant.
- Status – The current alert status. This contains a description of any warning or critical alert raised for the specified participant. For example if a student has pressed their "911" button, the status will indicate this.
- Pkt Rec Rate – The packet reception/error rate. This is the rate at which the TOC has not stored (error) data packets from each participant in the TOC database. If a manually invoked test has been started, this will show the reception rate from the beginning of the test. If no test has been invoked then this shows the reception rate over the last 10 minutes (10 minute rolling window.) The rate is calculated by the following formula:

$P_e$  = The number of time slices expected to receive a routed packet over the desired time period (e.g., If we should receive 2 routed packets per minute and we look over 10 minutes, then there should be  $2 * 10 = 20$  time slices where we expect to receive a packet.)

$P_r$  = The number of time slices where we actually receive a routed packet over the desired time period.  $E$  = The Packet Reception/error Rate displayed in the roster listing

$$E = (P_e - P_r) / P_e$$

- Msg Rec Rate – The message reception/error rate. This is the rate at which the TOC received neither a routed or un-routed/broadcast packet in each time slice over a given time period. Within a given time slice; the TOC should receive one routed packet and at least one un-routed/broadcast packet for each radio. For example, if the system is set to have 2 time slices (30 seconds per slice), per minute, then there are  $2 * 10 = 20$  time slices where we expect to receive one routed packet and at least one broadcast packet per slice, if we were to miss both a routed and broadcast packet during one of the 20 time slices, the Msg Reception/Error Rate would be  $1/20 = 5\%$ . The rate is calculated by:

$M_e$  = The number of time slices expected to receive either a routed or un-routed packet (message).

$M_r$  = The number of time slices where we actually receive a routed or broadcast packet (message) over the desired time period.

$$E = \text{The message reception/error rate} E = (M_e - M_r) / M_e$$

## For Official Use Only (FOUO)

- Last Updated – The date/time the last routed packet or broadcast packet was received by the TOC.

### 5.3.2 Security Administration

The TOC user's ability to set preferences such as passwords and display characteristics, as well as to access better configuration capabilities was increased. Security specifications, user authentications, new security class, AES encryption/decryption methods, deployed database tables, stored procedure code to support management of TOC users and roles to be used within the application were implemented.

Improvements associated with log-in identification, roles, security management and user password-validation were made. Implementation of the TOC (Tactical Operations Center) Application user administration screen was completed. This feature will allow "administrators" to create/manage/delete TOC Application users, as well as assign passwords and assign the proper security level to each user.

The secure login capability to the TOC Application is indicated below. Users are authenticated through a login screen, per image below.



Figure 41. TOC User Login

#### Login/authentication

- Three chances to authenticate before application closes
- Passwords stored in the database using one-way MD5 hashing algorithm using Electronic Codebook (ECB) block ciphering.
- Three Security Roles
  - Admin
  - Privileged
  - Basic

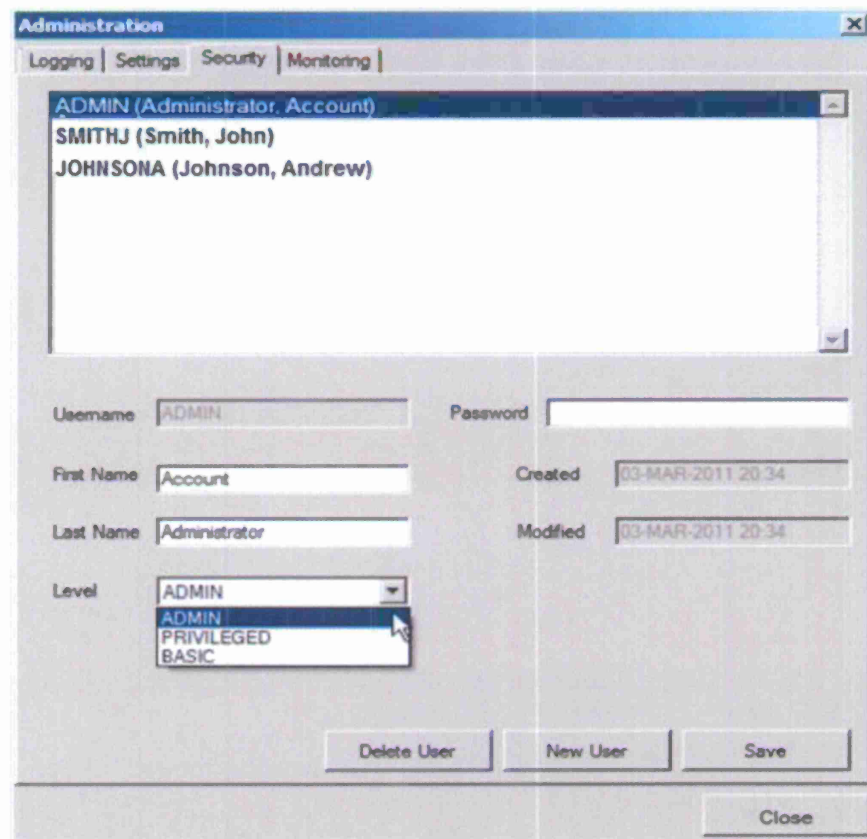

Figure 42. Security administration window

- Administrator may create, delete, or modify a TOC user.
- Only users defined through the TOC Security Administration component may use the application.

### 5.3.3 Performance-assessment Capabilities

Performance-assessment features to provide for the capture, storage and display of performance metrics, as required to support the demonstrations and characterization tests were implemented. The mapping software was modified to display the children of each parent node. This permits the current topology to be determined from the map screen. Display improvements were advanced to allow comparison of packet-reception via the instructor and via direct observation of trainee nodes. Other enhancements include the addition of slot assignments for all field nodes. The characterization activities conducted using these enhancements included: message delivery rate, time required for configuration/reconfiguration and adaptation to different topologies. Modifications to the TOC application main screen to display network packet-error-rate were completed. This feature allows graphing/charting capability to display time-series graphs of packet- error-rate. The TOC application system time was synchronized to the GPS signal to allow a single time reference for time stamp analysis. Modifications to the Data Broker software included new packet definition that stores the registration and re-registration times with a parent for each node.

Other improvements to the application includes the ability to recall old tests and meta-data to view previously run tests along with the time series graphs showing any error rates, as exemplified in Figure

43. This function is able to display routed and un-routed packet statistics. The ability to display time series error rates of individual radios was also implemented.

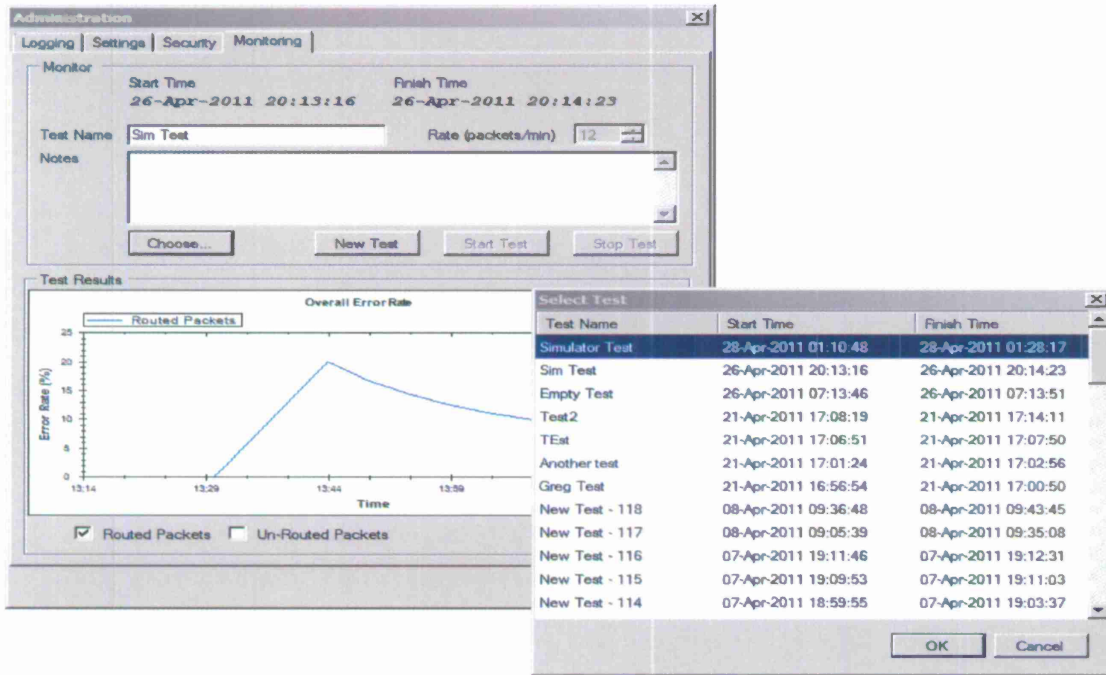

Figure 43. Recall of old test data and associated packet error rate of individual nodes



Figure 44. Time series graph of test error rate statistics

The capability to save the time series graphs was incorporated. As illustrated in Figure 44, right click of the mouse will present the user with various selections available for the time series graph, such as saving, printing and other configurations.

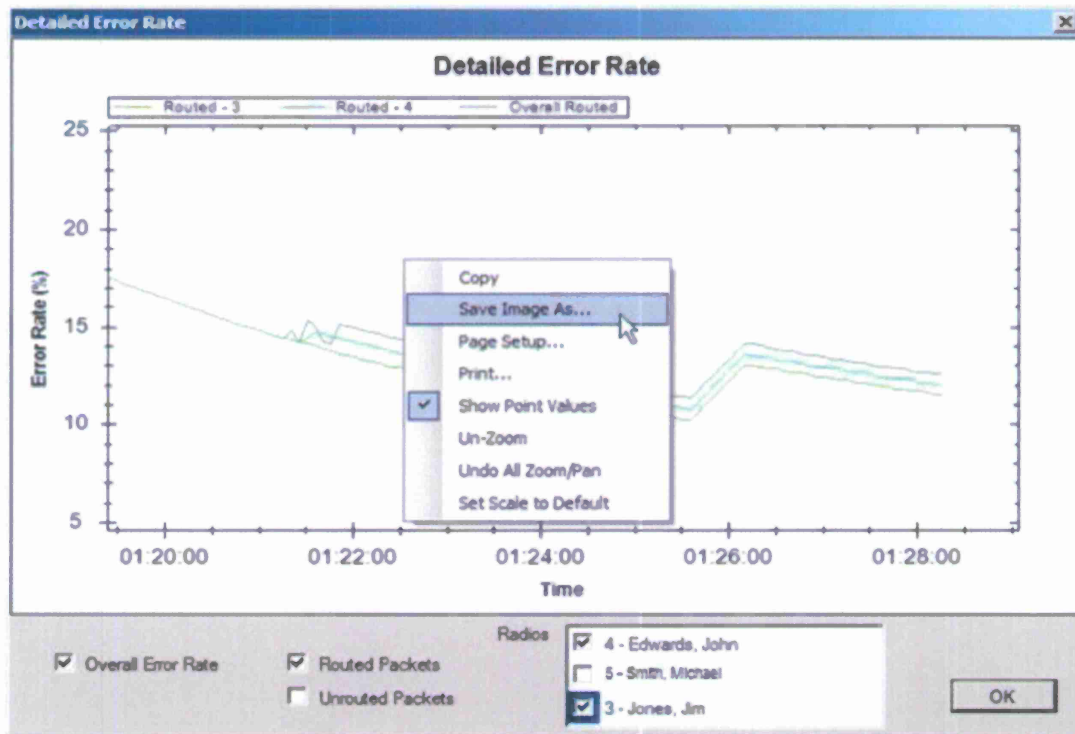

Figure 45. Time series graphs – save and print options

### 5.3.4 Sensor Information

TOC Workstation software modifications to support the reporting of heart rate information from the Zephyr/POLAR Bluetooth modules were completed. This involved modifications to the Data Broker software, application and underlying database code.

Heart rate tracking and plotting on a time series graph was implemented. Heart rate data was included in the data packet and in SparnetCore/SparnetMapControl.

The path was tested from an instructor radio to the handheld over Bluetooth and observed a heart rate value on the instructor's personal digital assistant (PDA) and subsequently to the Windows Tablet.

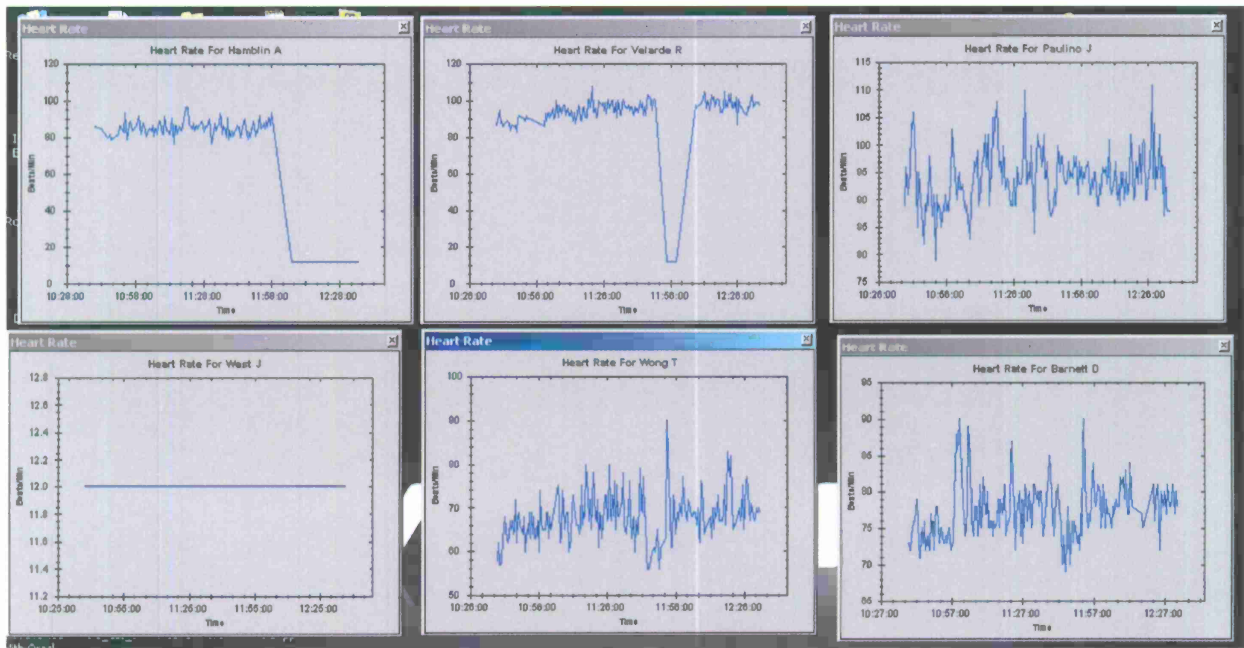

Figure 46. Heart rate plots for individual nodes

### 5.3.5 Playback Capability

The ability to play back training exercises from the TOC application-software collected data was advanced. When completed, this functionality will allow the user to playback any exercise stored in the database. Although the user interface for this functionality has been integrated in the TOC application, as illustrated in Figure 47, the utility requires additional work to enable its full operation. This feature, along with the ability to view raw log information, is envisioned to be provided as a standard capability.



Figure 47. TOC playback user interface

### 5.3.6 Log Utility Analyzer

Work on the "Log Analyzer", a utility to aid in post-test analysis of CLI and Data Broker log-files was advanced. A log-analysis utility was developed for processing all command line interface (CLI) log files generated by the individual radios as well as the TOC Data Broker log file. The utility aimed at producing summary results that are based on the data contained within the log files and the inter-relationships between the contents. This will allow the user to trace each packet through, from its origination to its destination.

#### 5.4 Instructor Handheld Application

The Mapping Control, which is central to both the TOC and the Instructor's mapping applications, was expanded to provide graphical information and alerts from a variety of new status indicators for each participant, including but not limited to geo-location, heart rate data and topology shifts.

An extension of the handheld interface to allow for bi-directional communication including downloading the roster to the radio was integrated and tested. This modification was made to provide capability for the instructor's mobile device to send the roster data it received from the TOC, such as slot assignments, personnel information, radio and network id, to the instructor assigned SAN radio, where the information is parsed for retransmission in control messages transmitted to student nodes.

Modifications to support the new registration scheme and outbound messaging were made. Preliminary message processing for incoming handheld messages in the radio was added, as was an application programming interface (API) in SparnetMapControl to send an outbound message from the Tablet/PDA/TOC PC.

Enhancements to the instructor's mapping application were executed in order to port the application from the PDA to the Tablet.

The main screen of the instructors map application is shown in Figure 48, with a screen shot of a roster shown in Figure 49. Figure 48 is a screen shot of simulated data on the Instructor's Tablet mapping application. When left-clicked on any icon, it will display a tool tip label that displays the roster number, the name of the participant, the heart rate, the MGRS geo-positional data, the distance in meters from the instructor, and the bearing to the instructor. For a detailed description of map icons and coloring schemes, see Section 5.3.1. The distance and bearing from the instructor is an important tool that can be utilized when a student is in need of assistance. The TOC operator can also set an alerting threshold that will notify the operator if any student has exceeded a pre-determined distance from the instructor.

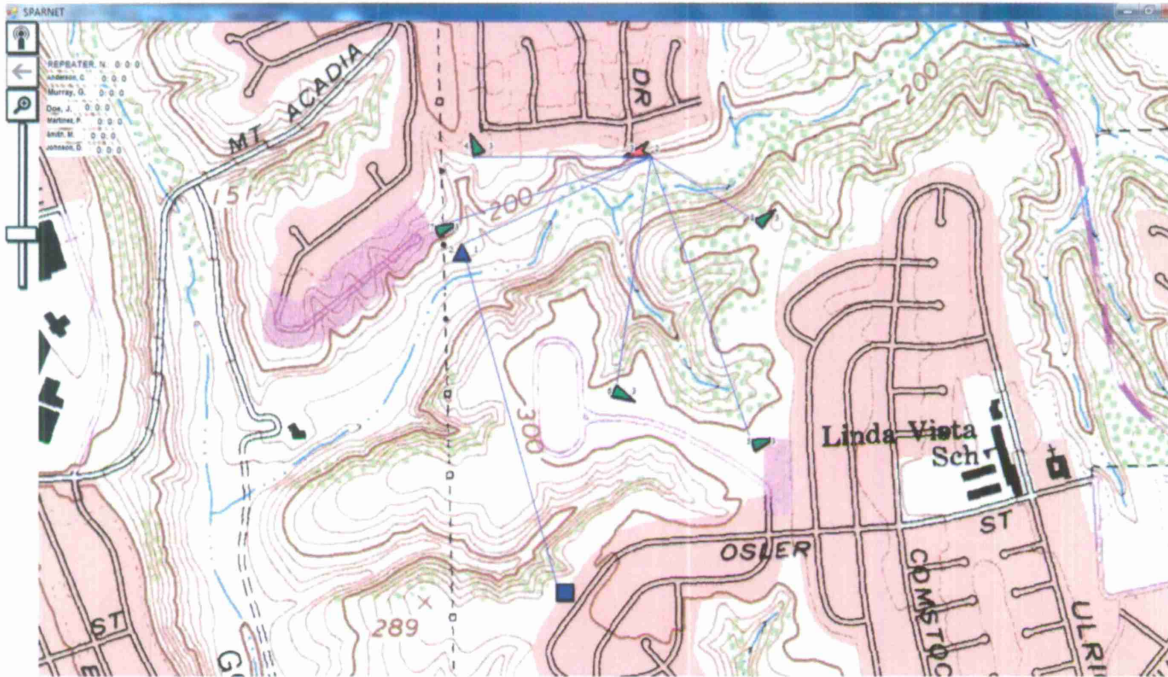

Figure 48. Instructor's map application main screen display (Tablet)

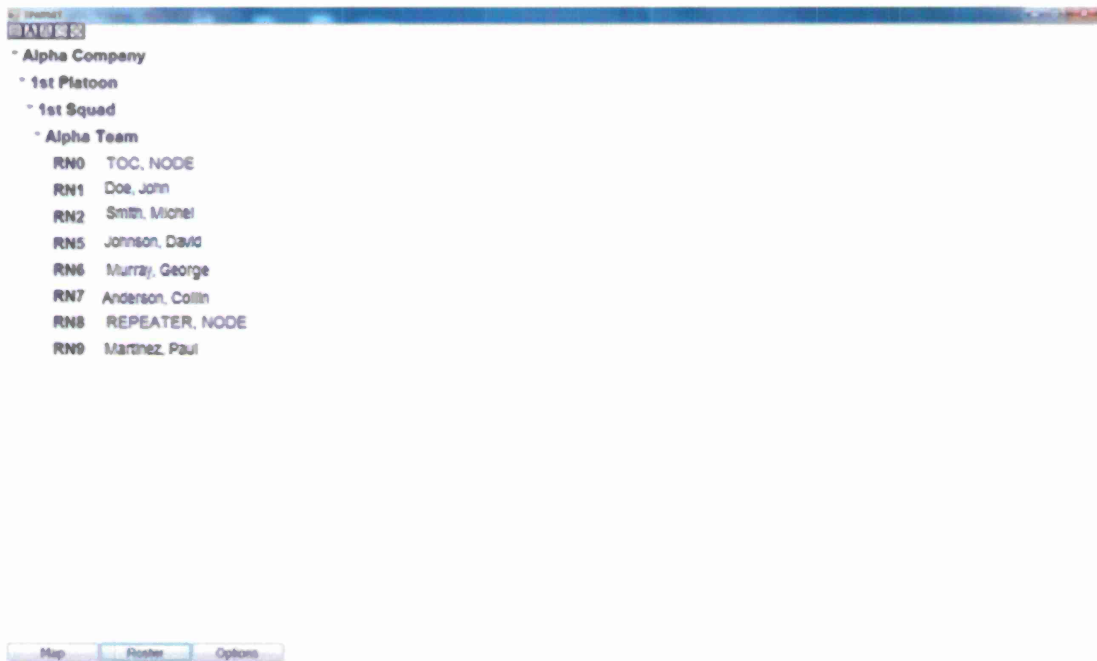

Figure 49. Roster screen shot of instructor's mapping device

#### **5.4.1 Purpose-built PDA Application for Bluetooth-enabled Sensor**

To satisfy the criteria of the Demonstration 3 requirements under PWS paragraph 3(f): Demonstrate direct I-PAN connection between on-body sensor(s) and the Instructor Node, bypassing the Student Node, a purpose-built PDA application which allowed the instructor node to directly link to a student-node sensor to monitor its heart rate was developed.

The connectivity is obtained by first turning off the student's radio to break the Bluetooth link between it and the student's heart-rate sensor. Next, the PDA formed a link to the student's heart-rate sensor and displayed the reading on the purpose-built software application, running on the PDA. The most current heart-rate value received from the sensor would be displayed.

The purpose-built application on the PDA had connectivity problems with associating with the student's POLAR heart-rate sensors during the execution of Demonstration 3. One of the issues was due to the termination of the link between the Bluetooth that resided on the PDA and the Bluetooth-enabled heart rate POLAR sensor. The connectivity did not always terminate from the previous sensor connection and consequently interrupted the new connection the PDA was attempting to make with the next student-node in line.

Accordingly, the PDAs were replaced with 10" Tablets (operating with Windows) to allow real-time observation of command-line-interface (CLI) messages, link-quality and node-performance. Other issues arose from transitioning from the PDA to the Tablet; however the principal issue was in the purpose-built application. The application intermittently was reading from the incorrect Bluetooth communication port. Migrating to the Zephyr heart rate monitors and implementing the use of their BioGauge application software resolved these issues and was validated in the execution of Demonstration 4.

#### **5.4.2 Handheld Speech**

Elintrix personnel collaborated with the author of Handheld Speech to successfully integrate its components in to the Handheld map-control application. The author provided the essential desktop project and binaries for the recognition engine and source code to enable Elintrix staff members to integrate. Elintrix provided a desktop map application test program of the instructor's map application to allow them to demonstrate voice activated switching between a communications application and a mapping application. Separate and collaborative efforts were made to debug the respective applications, such as glitches in enrollment and loading aspects of the Handheld Speech code. At Elintrix, enhancements were added for support of several voice commands (zoom in/out, show map, show roster, show options). Additional work was completed in order to enable the Handheld Speech application to run on the instructor's PDA and later on the Tablet.

The author had also set up the application to perform multi-part voice commands, as in "zoom to radio" (part 1) followed by an index (part 2). The communication application that was provided could be used for outgoing voice commands from the TOC PC. They also provided the source code for the text-to-voice component which would go in the SAN radio. It converts phonemes to a .wav file.

### **6 Analysis and Reporting of Network Performance**

Analysis and reporting of the results of demonstrations and performance-data were executed. Laboratory testing of system elements was ongoing. In preparation for the four required demonstrations and an interim December demonstration that occurred prior to the performance of

Demonstration 4, extensive indoor and outdoor testing of radios in Network Mode and Test Packet Mode to improve and optimize radio performance was performed. They were achieved by using over-the-air (OTA) Network Testing in effort to identify issues in the software code and optimize performance.

Radio logs were accumulated at each test occurrence and analyzed for the purpose of identifying/resolving issues and to optimize performance in preparation for the demonstrations, and to validate overall radio system operation and behavior. Extensive field-testing was conducted to obtain test-data, validate enhancements and perfective work, and to validate and rehearse the test plans for all demonstrations.

The Performance Work Statement (PWS) for U.S. Army contract number W911QY\_11-C-0012, "*Integrated Short Range, Low Bandwidth, Wearable Communications Networking Technologies*" sets forth specific demonstration and reporting requirements. Test plans were established that detailed the activities that were conducted in the field and in the laboratory to show that the performance-objectives associated with the four scheduled demonstrations for the Spartan network (SPARNET) were achieved. The aim of the test plan documentation was to define the methodologies whereby the intended characterization of performance was achieved in a feasible manner.

All four demonstrations were conducted at Marian Bear Memorial Park in San Diego, California.

## 6.1 Interpreting the Analyses

The number of nodes that can be supported by the network layer is scalable and configurable. For the tests reported in this document for Demonstrations 1-3, the network-layer was configured to support one TOC, one instructor and five student-nodes, with reporting updates at a rate of twice per minute. For the tests reported for the December Demonstration, the network-layer was configured to support one TOC, one repeater, one instructor and five student-nodes, with reporting updates at a rate of twice per minute. For the tests reported for Demonstration 4, the network-layer was configured to support one TOC, one repeater, one instructor and five student-nodes during one part of the test. The latter portion, the network was configured to support one TOC, one repeater, two instructors, and five student-nodes, with reporting updates at a rate of twice per minute.

Nodes are defined in the first column of Table 6 (Section 6.3.2) in terms of GUIDs (radio-specific serial numbers) and node-assignments, where the node number corresponds to the time-slot assigned to the particular radio. Under the new managed network scheme, the TOC operator designates the node slot assignments for the trainees in the exercise by composing the control message that the TOC transmits and propagates to the repeater and instructor nodes. In other words, the time slots for the trainees are static from the onset of the exercise. However, the TOC has the capability to dynamically reassign slot assignments and configure the squads, as necessary, for any given node during the exercise.

Anticipated routed packet-receptions correspond to the total number of routed data-packets that the Tactical Operations Center (TOC) application/database is expected to receive, based on the twice-per-minute update rate. For instance, if the data collection duration was for 5 minutes, the number of anticipated routed packet receptions would be equal to 10.

Error-count is the number of instances where the TOC did not receive a routed data packet through the instructor or the repeater for each node in the exercise. The number of un-routed packets is not being

calculated due to its complexity. Because the TOC node can receive packets from the surrounding nodes due to its more sensitive antenna, calculating the un-routed, anticipated packet receptions for the TOC node is challenging. In the case of the star topology, the number of un-routed packets received by the TOC is equivalent to the number of anticipated routed packet receptions. However, in topologies that are more complex than the star topology, the calculation must be conducted by analyzing the packet-hopping sequences and number of packets originated by each node. The calculation can be imperfect since, even though the TOC may be within distance of receiving a node's transmission, the signal may be too low to receive. This will impact the PER, which in the case stated above, the error may be legitimate.

A range of error-detection mechanisms are built into the radio algorithms, to aid in detecting, analyzing and resolving performance issues. These mechanisms can detect issues such as failure to properly decode the packet (manifested as cyclic-redundancy-check, CRC, errors), failure to resolve ambiguity that is a normal part of the synchronization process in quadrature receivers and failure to properly achieve phase-synchronization in a timely manner ("preamble" errors). Under normal operation, these types of errors can be expected to occur when the received signal has been excessively degraded by the channel.

The PER calculation is the percent of cases in which the TOC application did not receive an expected, routed packet for a node during the data collection period. For example, the TOC did not receive one data packet out of the anticipated 10 for GUID 2222. This error count equates to a 10% PER.

#### **6.1.1 Message Throughput Rate**

The message throughput rate is a calculation tallied based on the feedback regarding a separate network study. In the study, successful reception of any, routed or un-routed message received at the TOC application/database was counted as a successful message reception. The assumption is that it does not matter what route the message took to arrive at its destination, what matters is the message successfully arrived at its intended destination.

The message throughput rate column in Table 6 represents this assumption. The message throughput rate is computed the same way the PER is computed. Therefore, as long as the TOC received a packet for any given node (routed or un-routed) within each thirty second interval, then the message throughput rate is 100%.

The Anticipated Packet Receptions (Un-routed/Routed) column displays the number of un-routed or routed data packet that was received for the node during the data collection period, and that directly corresponds with the calculation for the message throughput rate column. The anticipated packet-receptions (un-routed/routed) correspond to the total number of un-routed or routed data-packets that the Tactical Operations Center (TOC) application/database is expected to receive, based on the twice-per-minute and/or once-a-minute update rate. For instance, if the data collection duration was for 5 minutes, the number of anticipated routed packet receptions would be equal to 10 for the twice-a-minute (30-second period) calculation and 5 for the once-a-minute (60-second period) calculation. In short, for this column, if the TOC receives both an un-routed and routed data packets for a node in a single frame, 30-second or 60-second, it will only count as 1 since the message throughput rate is calculated as a successful reception of any, routed or un-routed message received.

## 6.2 Demonstration 1 Results

The execution of month-4 Demonstration 1 was first attempted on April 28, 2011. Successful demonstration was prevented by an anomaly, the manifestation of which was first noticed in field testing of the integrated system. In follow-up laboratory testing, it was observed that transmitters sometimes abruptly began producing distorted outputs, significantly hindering successful communication with receiving nodes. The distortion was observed to be random and appeared to be more frequently-occurring on some boards. Initially, the problem was thought to be in the differential amplifier that drives the modulator integrated-circuit. However, subsequent to the demonstration, the problem was observed as distortion that occurred earlier in the analog signal-chain, in circuitry that resides on the digital CCA, not the RF CCA. Through investigative work, testing and collaboration with DAC experts at Analog Devices, resolution to the distortion issue was achieved. This issue was resolved by adding small capacitors between the input pin of the digital-to-analog converter (DAC) and ground. This improved the signal-integrity of the DAC output and eliminated the problem. As previously mentioned, the first attempt at executing Demonstration 1 was held on April 28, 2011. It is worth noting that Elintrix received permission to radiate on April 01, 2011. The reiteration of Demonstration 1 was executed on July 21, 2011. The timeline for the executions of the demonstrations was re-established to account for the delay in acquiring the permission to radiate, which prevented acquisition of results from tests conducted in the outdoor environment. Below are the subsections that identified the issues experienced during the demonstration and/or during study of the recorded activity logs.

Demonstration 1 was performed on 21 July 2011 at Marian Bear Memorial Park in San Diego, California. A technical report and a disc comprised of the final technical report, log-file activities and other accompanying files were submitted to the customer.

The subsections that follow discuss issues that were identified during Demonstration 1 and subsequently corrected. These issues were no longer present during the operations of Demonstration 2 and Demonstration 3.

### 6.2.1 Packet Errors

Following the completion of a software-utility, the cause of elevated packet-error-rates was successful traced to a sporadically-occurring, anomalous behavior in the automatic-gain-control (AGC) algorithm. Investigation focused on the analog automatic-gain-control revealed that the attack-rate (adjustment speed) was inadequate. The attack-rate was adjusted and reduced the associated packet-error-rate. The AGC was optimized to reduce the receive sub-buffer size to improve the R.F. AGC attack time. The current scheme operates making adjustments in 6 dB steps, as opposed to the previously-employed 2.5 dB steps.

In addition to the improvements in attack-rate, remnants of code thought removed in earlier work were found to have been overlooked. The redundant code was removed, resulting in a significant improvement in the packet-error-rate.

### 6.2.2 Packet-detection Issue

In reviewing logs recorded during the demonstration, instances were observed wherein a radio would randomly miss detection of packet-energy and did not process the buffered samples. This problem was observed to variably affect radios, but most specifically and severely affected the node selected to serve as the instructor node, thus having a significant effect on the logged packet-error-rate performance of the overall system. The packet-detection issue was caused by improperly terminated chip-select lines

associated with a SPI bus. This caused the digital-to-analog converter (DAC) that controls the automatic-gain-control-variable-gain-amplifier to be randomly set to an inappropriate setting, causing it to be placed in a maximum-attenuation state. Instances were observed wherein a radio randomly missed detection of packet-energy and did not process the buffered samples. This problem may also have been exacerbated by the code remnants, described in 6.1.1. Corrective actions eliminated the issue.

### **6.2.3 Network Registration**

Conditions in which incomplete registration exchanges between a prospective child and its candidate parent result in an inaccurate child-node table at the parent node were identified through analysis of the demonstration logs. The code was modified to eliminate this bug for the execution of Demonstration 2 and Demonstration 3. The removal of the ALOHA registration scheme and the integration of the managed network architecture for Demonstration 4 has rendered this issue moot.

### **6.2.4 Measurements**

Measurements were made on actual hardware to acquire estimates of power consumed across the set of inter-node communications. Antenna pattern-characterization testing was conducted. Field measurements made to determine best-, intermediate- and worst-case orientations for the rubber-ducky and body-worn antenna units. Measurements were made to obtain the power-consumption characteristics of the radio, across various packet-types during transmission and reception. Results of the measurements were incorporated into the demonstration technical report submitted to the customer.

## **6.3 Demonstration 2 and Demonstration 3 Field and Laboratory Results**

Demonstration 2 was performed on Thursday, October 27, 2011. Demonstration 3 was executed the following day, Friday, October 28, 2011. Demonstration 2 and Demonstration 3 were conducted as completely-separate efforts, even though various demonstration requirements for Demonstration 3 were previously exercised during Demonstration 2. The squad-area-network (SAN) radio code-revision used in both demonstrations was identical. Performance similarities and issues cited in the two technical reports were attributable to the common code-revision. Identical issues appeared during the two-day presentation, as the heart rate monitoring units were integrated for Demonstration 2, as well as Demonstration 3. The link between the use of the heart rate monitors and the issues that were experienced are detailed, in the following sections.

Work was advanced to implement the various functionalities to facilitate a successful Demonstration 2. Store-and-forward architecture and re-registration algorithms were advanced. De-registration of nodes was optimized, as well as transmission of child-report messages to inform the previous parent of registration with a new parent. Integration of Liquid-crystal-display (LCD) to show relevant radio node metrics was achieved. The display of geo-location and identification of each node as iconic information overlaid on a displayed map at both the instructor node and TOC node was verified.

Concurrent foundational work was advanced to support Demonstration 3 and implement month-9 functionalities such as, design of a Bluetooth option-card, integration of POLAR heart rate monitor units and enhanced 911-message transmission. Work to incorporate the reporting and display of the trainee's heart rate in the network, as well as, the TOC application/database and instructor's mobile devices was progressed.

### 6.3.1 System Reliability during Demonstration 2 and Demonstration 3

Certain issues were experienced during the demonstrations. These issues negatively affected the system's ability to maintain the intended network topologies. It also impacted the time it took to form the topologies, as nodes that experienced the problems had to be turned off and, then, on to clear the problem. Power cycling was a temporary fix to reset the code. When this occurred, time was consumed to re-acquire a GPS lock and to re-register with the previous parent in order to reestablish the target topology.

Following the demonstrations, the engineering team focused on resolving issues that produced system instability during Demonstration 2 and Demonstration 3. Experimental work revealed that the introduction of Bluetooth-enabled heart-rate monitoring resulted in the unexpected, randomly-occurring issues with radios, during the demonstrations.

The team worked aggressively to diagnose the exact problem and arrive at a resolution in an expeditious manner. Lab testing of the radios revealed that when the Bluetooth-enabled heart-rate monitors were integrated into the system, the radio operation would "lock-up". In other words, the code was halting radio operation when the heart-rate modules were active. Therefore, in previous field testing of the system, which was conducted prior to the addition of the heart-rate monitor code, the lock-up anomaly did not occur.

It was discovered that recycling the power of the radio unit would temporarily eliminate the problem, but it would eventually reasserted itself, again. Vendor representatives were contacted for feedback and support in the matter, instituting a parallel effort between the factory and the engineers.

Subsequently, Elintrix engineers diagnosed the issue as being related to the serial peripheral interface (SPI) communication between the MSP430 and Blackfin processors. Corrective changes were made to the code and extensive lab- and field-testing were conducted to obtain data to validate enhancements and corrective work applied to the code. Proper operation was confirmed.

Issues experienced with the TOC application during the demonstrations were traced back to the Windows 7 operating system (OS). Elintrix has two laptops in use, one with Microsoft (Redmond, WA) XP OS and the other with Windows 7 OS. The TOC laptop with the XP operating system has been mainly used in all the testing, up until the last week leading to Demonstration 2 and Demonstration 3. An internal decision to change laptops prior to the demonstrations was ill-advised. The main reason for doing so was to have the better screen-resolution provided by the Windows 7 OS unit. The Windows 7 laptop has been mainly used for development of the application and database.

During detailed analysis of data collected on the TOC Data Broker, it was discovered that a certain number of data packets were malformed. The TOC radio node accurately received the data packets from the surrounding nodes, as verified using the TOC radio's command-line-interface (CLI). So, the malformed packet was not a radio-reception issue. The malformed packet issue was happening when the TOC radio communicates the received data packet via the serial-port cable to the Data Broker, where the data is then fed into the TOC map application. This issue contributes to a higher packet error rate, as calculated on the TOC application. This is because the Data Broker cannot decipher the distorted data-packet messages that are used to update the TOC application.

## For Official Use Only (FOUO)

The malformed packet issue experienced during Demonstration 2 and Demonstration 3 was corrected. The malformed packets occurred when the TOC radio communicated the received data packet via the serial-port cable to the Data Broker, where the data was then fed into the TOC map application. This issue contributes to a higher packet error rate, as calculated on the TOC application. This is because the Data Broker cannot decipher the distorted data-packet messages that are used to update the TOC application. The basic fix was to implement a circular buffer to send the handheld packets from the TOC radio. The original buffering scheme that was implemented was not circular and was overwriting the buffer every time a packet was to be transmitted. If a packet was queued and a new packet is loaded into the queue, the old queued packet would be chopped off, or malformed. The buffer was also increased, which optimized the circular buffer. In summary, this issue was not one wherein the TOC radio had incorrectly received a packet. It was one in which the stored packet could occasionally be overwritten before being sent to the TOC application by the radio. This matter has been corrected and the issue of malformed packets has been eliminated.

A couple of issues stemming from the inconsistencies related to the invitation interval hindered the proper operation of the system, and consumed excessive amount of time for the formation of the intended demonstration-topologies. A node will attempt to register with the first invitation it receives with any candidate parent node. It will transmit a response to the candidate parent and will ignore other invitations it receives thereafter. The issue occurred when the registration process failed and the node would remain in the "ignore invitation" condition. Even though it received invitations from a more suitable candidate parent, the node remained in this loop. It was discovered that if a node deregistered, it would reset the state or a power-cycle was necessary to clear the manifestation. The metric to register with a candidate parent node was a properly-received invitation packet. The instructor node and student nodes were fitted with 10dB fixed attenuators for the duration of Demonstrations 2 and 3. This was to provide better control over the field-strengths when attempting to form the linear topology, reducing ranges to manageable levels. It was sometimes difficult to force the network to assume a desired topology, even when the signal strengths were low and environmental features were used as an aid in blocking signals. Such tests of network-configuration behavior are better conducted in laboratory settings, where greater control can be maintained throughout the test.

Revision of the network-layer to eliminate the ALOHA registration-scheme and to introduce additional features that significantly increase the efficiency and robustness of the features could not be completed in time to allow sufficient testing, prior to Demonstration 3. In subsequent testing, significantly-improved system-stability and performance were tested and verified.

In addition to the issues listed above, on the second day of the demonstration-period (Demonstration 3), the node-configuration portion of the demonstration manifested an issue that was related to how the TOC-node data information was stored on the Roster. This created a problem with the extensible markup language (XML) parsing code on the handheld application. When the instructor attempted to load the Roster in to the PDA, via a compact FLASH (CF) card, the instructor's handheld application did not recognize the format. This issue has since been resolved. The instructor's personal digital assistant (PDA) also had difficulty accessing the Bluetooth Manager on the PDA's Program Files. For a reason that remains open, the Bluetooth Manager did not appear under the iPAQ wireless menu, and only showed the WiFi connectivity. This issue is not present with the use of the Microsoft Windows Tablets, which was integrated in place of the PDA's for Demonstration 4.

During field testing, some anomalous behavior was observed when certain heart-rate monitors failed to connect and provide the expected reading. Heart rate work was reworked to focus on the Zephyr BioHarness 3, as this unit contains USARIEM algorithms.

**6.3.2 Demonstration 2 Results**

Table 6 represents the analysis of the data during the 10-minute data collection for the linear topology. Table 7 represents a modified calculation of the recovered data packet transmissions for nodes 4 and 5 after re-registering with a suitable parent. The 9 missing data packets for GUID 6666, node 4 and 8 out of 9 missing data packets for GUID 9999, node 5, were recovered during this time.

The error rates for GUID 7777, node 3, and GUID 2222, node 2, were due to GUID 5555, node 1. At their respective time slots, each node transmitted their data packets to their corresponding parents: GUID 2222 is the parent of GUID 7777 and GUID 5555 is the parent of GUID 2222 and grandparent of GUID 7777.

Reception by the parent node (the instructor) of data packets from GUID 5555 (a child of the parent) were intermittently declared as being too degraded for proper reception. Since the instructor radio was not able to properly decode the packet, it was not routed to the TOC and resulted in a “routed” packet error.

The issue was subsequently investigated in the laboratory and found to be caused because GUID 5555’s drive-level to its power amplifiers was not appropriately adjusted. Inappropriately-adjusted drive levels of this type cause distortion of the transmitted signal and negatively affect reception-processing. The drive-level was properly readjusted and the reception issue was eliminated.

**Table 6. Packet Error and Message Rate – Linear Topology, Demonstration 2**

<b>NODE</b>	<b>Parent slot</b>	<b>Anticipated Routed Packet Receptions</b>	<b>Error Count</b>	<b>Packet error rate (PER) in %</b>	<b>Anticipated Packet Receptions (Un-routed/Routed)</b>	<b>Message Throughput Rate in %</b>
GUID 1111, Instructor	255	20	0	0	20	100
GUID 5555, node 1	254	20	1	5	20	100
GUID 2222, node 2	1	20	3	15	20	100
GUID 7777, node 3	2	20	4	20	20	100
GUID 6666, node 4	3	20	9	45	11	55
GUID 9999, node 5	4	20	9	45	12	60

**Table 7. Recovered Store-and-Forward Packet Transmissions from Table 6, Linear Topology, Demonstration 2**

<b>NODE</b>	<b>Parent slot</b>	<b>Anticipated Routed Packet Receptions</b>	<b>Error Count</b>	<b>Packet error rate (PER) in %</b>	<b>Anticipated Packet Receptions (Un-routed/Routed)</b>	<b>Message Throughput Rate in %</b>
GUID 1111, Instructor	255	20	0	0	20	100
GUID 5555, node 1	254	20	1	5	20	100
GUID 2222, node 2	1	20	3	15	20	100
GUID 7777, node 3	2	20	4	20	20	100
GUID 6666, node 4	3	20	4	4	20	100
GUID 9999, node 5	4	20	1	5	20	100

**6.3.2.1 Overall Packet-Error-Rate (PER) and Message Throughput Rate for Full Duration of Demonstration 2**

Table 8 illustrates the overall PER and message throughput rate for the full 2 hour duration of Demonstration 2 functionalities. The PER is an aggregate of the system reliability issues the individual nodes experienced, which have been referenced in Section 6.3.1. The store-and-forward function was able to restore a great number of packets that were otherwise “lost” in the routed packet receptions, as well as the message throughput rate. Table 9 illustrates the original PER for the nodes and the recovered number of data packets once the store-and-forward functionality was triggered. For example, during the execution of the store-and-forward functionality, 10-minute separation of 2 nodes, GUID 1111, instructor radio experienced an exception where its radio locked-up and had to recycle power. Its downtime was between 17:58:30 and 18:06:36. During this time, with the exception of GUID 5555, node 1, the instructor’s children began broadcasting their data packets and storing and incrementing their store-and-forward data packets. The node’s broadcasted data was received by the TOC radio node and attributed to an improved message throughput rate. The transmission of the store-and-forward data packets, once the nodes reregistered with the instructor and their respective parents, improved since the “lost” packet was retransmitted in the node’s store-and-forward interval. Unfortunately, GUID 5555’s radio also locked on two occasions and did not activate the store-and-forward functionality and had no way of recovering its data during these times.

In different points of the test, GUID 1111, instructor node and GUID 5555, node 1 experienced radio performance issues that caused their individual radios to lock-up, and therefore needed to recycle their power to clear the exception. When a radio’s power is recycled, it refreshes its network condition. A node first has to deregister and broadcast its data for the store-and-forward to commence. For the rest of the nodes, even though the instructor’s radio had powered off, and they no longer had a viable parent to route their data packet to the TOC node, they individually began broadcasting their data packets and the TOC node was able to receive their un-routed packets. Once the instructor was back on the network, the nodes began transmitting their current and stored data packets in their buffer queue

For Official Use Only (FOUO)

Table 8. Overall calculation of error rates for full duration of Demonstration 2

Nodes	Duration (Approximately 2 hrs)	Anticipated Routed Packet Receptions	Error Count	Packet error rate (PER) in %	Anticipated Packet Receptions (Un- routed/Routed)	Message Throughput Rate in %
GUID 1111, Instructor	17:38:8 19:36:8	236	79	33.5	157	66.5
GUID 5555, node 1	17:38:10 19:36:10	236	79	37.3	181	76.7
GUID 2222, node 2	17:38:14 19:36:14	236	65	27.5	227	96.2
GUID 7777, node 3	17:38:18 19:36:18	236	64	27.1	226	95.8
GUID 6666, node 4	17:38:22 19:32:54	229	65	25.8	216	94.3
GUID 9999, node 5	17:38:26 19:33:26	230	63	27.4	212	92.2

Table 9. Recovered Data Packets

Nodes	Duration (Approximately 2 hrs)	Anticipated Routed Packet Receptions	Original Error Count	Packet error rate (PER) in %	Recovered number of Packets	Packet error rate (PER) in %	Improvements calculated in %
GUID 1111, Instructor	17:38:8 19:36:8	236	79	33.5	0	n/a	n/a
GUID 5555, node 1	17:38:10 19:36:10	236	88	37.5	0	n/a	n/a
GUID 2222, node 2	17:38:14 19:36:14	236	81	34.3	16	27.5	6.8
GUID 7777, node 3	17:38:18 19:36:18	236	88	37.3	24	27.1	10.2
GUID 6666, node 4	17:38:22 19:32:54	229	94	41	35	25.8	15.2
GUID 9999, node 5	17:38:26 19:33:26	230	106	46.1	43	27.4	18.7



**Figure 50. Illustration of Linear, 5-Hop Topology Demonstration**

### **6.3.3 Demonstration 3 Results**

In Table 10, the high error count for GUID 2222, node 2 is due to radio operation locking-up and the node had to recycle its power at 18:05:59, to clear the event. Since this was during the data collection period for the linear topology, 2 minutes of its data was not transmitted during this time and accounts for its high PER and lowered message rate throughput. These data packets are not recoverable since power-cycling refreshes its network framework. Node 2 radio power cycling greatly impacted the rest of the nodes in the topology, who were relying on node 2 to forward their individual data packets to the instructor. Node 2 is the direct and indirect parent of nodes 3, 4 and 5. In the linear topology, the only other suitable candidate parent node that node 3 can re-register with was node 1. It cannot register with either nodes 4 and 5 since they are the child and grandchild of node 3. The distance between nodes 1 and 3 was approximately 112 meters and 20dB of attenuation between the two nodes, which was not favorable to allow a registration to occur. The distance between node 3 and node 1 would have to be reduced in order for registration to transpire. As it was, the objective was for all nodes to hold their position until node 2 re-acquired a GPS fix and repossess its place in the linear topology, in order to continue with the demonstration, as planned. The TOC was continually receiving un-routed packets directly from the nodes during this time, with the exception of node 2. Therefore, the message throughput rate for nodes 3, 4 and 5 was not impacted.

Other issues present during this segment of the demonstration were the link quality between the nodes that created additional errors to occur.

Table 10. Packet Error and Message Rate – Linear Topology, Demonstration 3

NODE	Parent slot	Anticipated Routed Packet Receptions	Error Count	Packet error rate (PER) in %	Anticipated Packet Receptions (Un-routed/Routed)	Message Throughput Rate in %
GUID 1111, Instructor	255	20	2	10	18	90
GUID 5555, node 1	254	20	8	5	20	100
GUID 2222, node 2	1	20	4	20	16	80
GUID 7777, node 3	2	20	6	35	20	100
GUID 6666, node 4	3	20	8	35	19	95
GUID 9999, node 5	3	20	8	40	18	90



Figure 51. Illustration of Linear, 5-Hop Topology Demonstration

**6.3.3.1 Linear Topology and 911 Demonstration**

The transmission of 911 messages from each student node to the instructor node and TOC node was demonstrated using the linear topology, following the 10-minute store-and-forward demonstration. Each student-node was instructed to press their 911 alert button, the reception of which was confirmed by observing the TOC application and the instructor application. The visual display of a received 911 transmission, by a student-node, via the TOC and instructor applications was verified by the node’s icon turning from green (TOC is continuously receiving data packets from node) to red. An icon turning red can signal either a 911 event has occurred and/or, depending on the configurations the TOC operator had set on the application, can also indicate that a critical threshold has been exceeded. The reception of the 911 message transmission was visually confirmed by the customers stationed at the TOC location,

while another customer was stationed with the instructor, in the field. The 911 demonstration was performed starting with the last node in the topology link, node 2, and finishing with the instructor.

The message transmission latency (transit time) measured by the customer was between 7 seconds to 30 seconds.

#### **6.3.3.2 Laboratory Demonstration Activity of Store-and-Forward (30-minutes, 2-node, separation)**

With respect to the store-and-forward, the half-hour-long separation was demonstrated in the lab, using attenuators to separate the nodes from the rest of the network.

The following laboratory-demonstration activity showed the operation of the store-and-forward feature of the network for the case of 30-minute separation of two nodes. After expiration of the 30-minute separation-period, the first node was reestablished as a leaf node. Next, the second node rejoined the network as a child of the first node, transforming the first node from a leaf (child) to a branch (parent) node.

The test was terminated after all stored packets have been transmitted by the respective nodes-of-origin. By previous agreement, the nodes did not maintain subnets because this does not optimally facilitate independent reconnection and the stored data gets forwarded, regardless.

From the perspective of timely re-registration and data-transfer, this design is more efficient under the unique operational-requirements and constraints of the SPARNET system. Accordingly, subnet operation is intentionally not supported by the SPARNET network-layer and was not demonstrated. However, the independent separation and independent rejoining of nodes is consistent with the more rapidly-reconfiguring model and was demonstrated for cases in which nodes that have rejoined the network and are forwarding data will operate as a parent- (branch) and/or a child-node (leaf).

Table 11 below represents the recovered data packets for the span of 30 minutes for which the two nodes were disconnected from the network. All the routed, stored packet errors the two nodes encountered were due to the TOC radio receiving the forwarded data packets from the instructor as preamble errors, with a high AGC power level.

Performance of this portion of the demonstration in the lab environment, with radio nodes being such a close distance from one another, the TOC radio failed to receive the transmissions correctly. This problem is known to the design-team and future work and enhancements will be made to address this matter.

The percent of error for node 5 in the message throughput rate column is due to the TOC Data Broker determining the packets as malformed. The TOC node received all of node 5's routed and un-routed, stored packets, as evident in the TOC CLI, but the Data Broker could not decipher the data-packet messages.

**Table 11. Packet Error and Message Rate for 30-minute, 2-node, Store-and-Forward**

Off-net Nodes	Recovered Separation Time (30 mins)	Anticipated Routed Packet Receptions	Number of Received routed, stored packets	Packet error rate (PER) in %	Anticipated Packet Receptions (Un-routed/Routed)	Message Throughput Rate in %
GUID 6666, node 4	23:15:22 – 19:44:52	60	52	13.3	60	100
GUID 9999, node 5	23:15:56 – 23:45:26	60	58	3.3	58	96.7

**6.3.3.3 Overall Packet-Error-Rate (PER) and Message Throughput Rate for Full Duration of Demonstration 3**

An overall PER and message throughput rate was not calculated for the full duration of Demonstration 3. The rationalization behind this was that the error rates would be misleading based on 2 conditions: a) student-node radios were powered off during the bypass connectivity demonstration (Section 5.10 of Demonstration 3 technical report) and b) the ad-hoc test initiated by the customer at the conclusion of the formal Demonstration 3 requirements. As previously mentioned, the same code revision resided on both Demonstration 2 and Demonstration 3. One can infer that the overall calculation of error rates for Demonstration 2 would be the similar to that of Demonstration 3.

**6.4 December Demonstration**

This previously-unscheduled, interim demonstration, held on December 16, 2011, was conducted to showcase the progress made in resolving issues of system stability that were observed in Demonstration 2 and Demonstration 3. The enhanced registration architecture, which eliminated the ALOHA invitation scheme, was demonstrated, along with an integrated Repeater which served as a communication backbone between the field and the TOC radio. The removal of the ALOHA scheme and the integration of the new managed network architecture resulted in a more reliable and robust registration process, and eliminated inconsistencies and issues associated with the ALOHA architecture. Key objectives of engineering the SPARNET network-layer to operate as a "managed network" maximized graceful control of the system and provided greater flexibility to tailor the system to meet application-specific requirements and enabled the best use of the limited spectral bandwidth provided for the network.

A repeat of the combined elements of Demonstration 2 and Demonstration 3 were demonstrated. Functionality intended for Demonstration 4, integration of a repeater-node, was exercised. The aim was to have the instructor register with the repeater as opposed to the TOC radio node. During the demonstration, the instructor registered with the repeater node, which was registered with the tactical operations center (TOC). This displayed a network self-configuration with the TOC as a root and the repeater node as a child.

At the conclusion of the December demonstration, a range test was conducted to exhibit the advancement of the radio performance. The test consisted of the TOC, repeater, instructor and 5 student nodes. The distance was demonstrated between an instructor node and 1 student node (Radio 19, node 5), with the use of the high-power power amplifier. The rest of the nodes were operating using

the low-power power amplifier. The maximum distance reached between the two nodes exceeded 1000 meters, with 0% message-error-rate. The location of the various nodes during testing is shown in Figure 52.

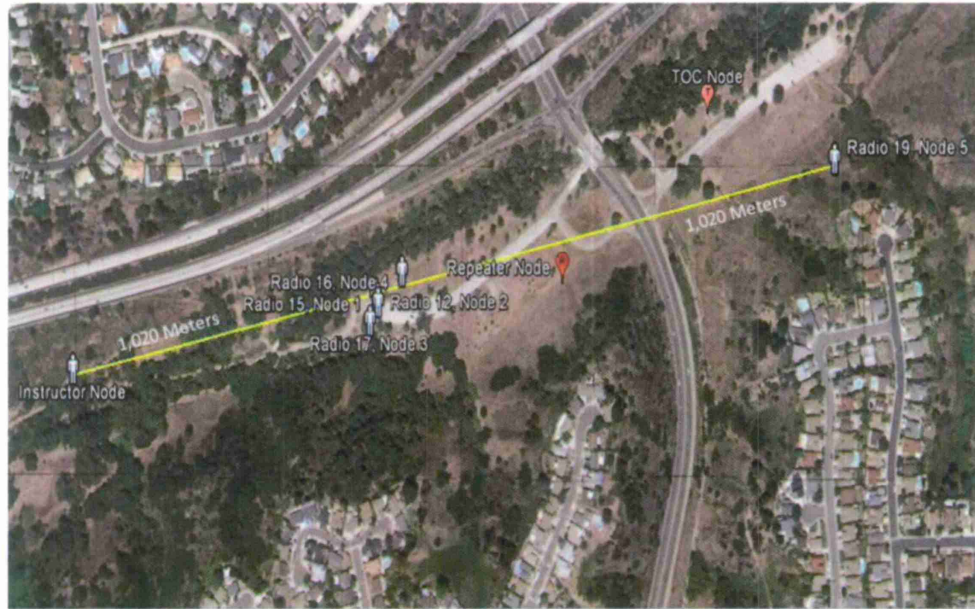

**Figure 52. Illustration of Range Test, between Instructor and student node**

There were several issues present during this demonstration. The bypass-connectivity demonstration (student-radio bypass per PWS 3f) still had issues with connection between the instructor's Bluetooth-enabled tablet and the student node's POLAR heart rate monitor. This issue was resolved by moving forward with the Zephyr heart rate monitor units for Demonstration 4. A series of clean-up activities were concluded based on the outcome of the December demonstration. Most of which were related to the applications.

All in all, this demonstration illustrated a powerful and reliable system capable of bypassing the threshold range requirement and achieving the objective distance of 1000 meters, as specified in the project work statement (PWS).

## **6.5 Demonstration 4 Results**

Demonstration 4 was concluded on February 02, 2012. Foundational work was advanced to support Demonstration 4 functionalities such as, integration of the new managed network scheme, construction of the repeater backbone, integration of the Zephyr BioHarness 3 heart rate monitor units and bi-directional communication via 911-messaging. Work to advance aspects of the Option Year 1 tasks, such as the operation of multi-squad and multi-instructor network, as well as the recovery of an off-network student was achieved. The capability to store, format, download and the subsequent exporting of data stored on an individual node was executed. The capability for the TOC to import and export roster data and equipment list was advanced. Handheld Speech's voice command of the instructor's mapping application was demonstrated.

### 6.5.1 Issues Observed in Demonstration 4

There were two key issues cited in the Demonstration 4 technical report. One occurred in the field where the repeater node would intermittently receive the instructor node's forwarded data packets as errors. The second being the laboratory portion of the demonstration wherein the instructor's radio did not parse correctly.

#### 6.5.1.1 FLASH Parser

During the laboratory execution of the parsing of the downloaded node data for the instructor's radio node, the downloading of the stored flash data for the instructor's radio did not function properly. The "dump 8" command was successfully executed from HyperTerminal; however the flash parser produced a file with no lines of text. Below are the first few lines of the captured text from HyperTerminal.

```
[54:39.329] Batt is 6.850 Vdc[54:39.334] State is GREEN
```

```
[54:39.340] sparnetP3>
```

```
[54:40.140] sparnetP3>
```

```
[54:40.324] sparnetP3>
```

```
[54:40.478] sparnetP3>[54:40.552] BT No Carrier Link0
```

```
[54:40.557] HR was 12 at 00:00:00, now 0
```

```
[54:40.642] sparnetP3>
```

```
[54:40.826] sparnetP3>
```

```
[54:40.955] sparnetP3>dump 8
```

```
Flash Log[14500]=...
```

```
0,
```

```
50,
```

The parser is intended to read HyperTerminal's captured text line by line and begin to process data immediately after the string "Flash Log [14500]". The text filter, or regular expression, was based on searching, rather than matching, a line of text that contains an integer followed by a comma (i.e. '(\d+),' in Python notation). Notice that the line with time-stamp [54:40.557] contains a string with this property, namely "00:00:00,".

At the time of the demonstration, the parser's logic was correct, but slightly flawed. Once a string of the time specified above was encountered, the line was deemed to be a byte from the radio's FLASH memory. Moreover, when a line of this type was no longer encountered, the line was deemed to no longer be from the radio's FLASH memory, and the parser was terminated. The line immediately following the line with time-stamp [54:40.557] is blank and therefore was considered to not be part of FLASH memory. As a result no packet was processed. The problem has been solved by using matching rather than searching. Moreover, the FLASH processing is terminated only after the FLASH dump completion message is observed in the log file. With these changes, we have been able to successfully dump and parse the FLASH memory from the instructor's radio.

#### 6.5.1.2 Intermittent Packet Reception Issue between Instructor Node and Repeater Node

All testing to date has demonstrated that the issue where the repeater node would intermittently receive the instructor's forwarded data packet as an error is attributed to the spurious components

originating at the affected instructor-node. Under several testing conditions, the original instructor radio, used during the execution of Demonstration 4, was substituted for another instructor radio node and the original repeater radio was integrated and used for these testing purposes. Examination of the collected data showed that the probability of the error occurring markedly decreased with the replacement of the instructor node. Further investigation and debugging of the instructor radio node will be necessary to isolate and determine the precise source of the problem.

### **6.5.2 Update Rate Calculations of 30-second Period vs. 1-minute Period**

The node count requirement for base year one of the project consisted of demonstrating support for one TOC, one repeater, one instructor and five student-nodes. The SPARNET network layer was scaled and configured to serve this purpose. The network was designed to update twice-a-minute (30-second period) for the purpose of the demonstrations. Two sets of metrics were calculated for the individually executed requirements set forth under Demonstration 4: twice-a-minute (30-second period) and once-a-minute (60-second period). The reporting of packet error rate and message throughput rates were calculated separately based on these two metrics.

The set of data contained in Table 12, Table 14, Table 16, Table 18, Table 20 and Table 22 is for the twice-a-minute (30-second period) update rate and the same data sets were recalculated based on the once-a-minute update rate as exemplified in Table 13, Table 15, Table 17, Table 19, Table 21 and Table 23. Even though the SPARNET network updates twice-a-minute (30 second period), in the recalculation, the basis was that if any data packet was successfully received by the TOC for an end node, within a span of a minute, it was deemed to be a successful packet reception. As an example, if the TOC received a bad packet or no packet at all for node 4 at 02:21:00 (hh:mm:ss), but received a good packet for node 4 at 02:21:30, in the recalculation, this would only count as 1 good data packet reception for the one minute time frame of 02:21:00-02:21:30. This is the foundation of the metric for calculating the error rate and message throughput rate for the contract-specified 60-second period (1-minute). Each data packet transmitted by a node is unique, frame-by-frame, as Elintrix did not conduct any of the four required demonstrations with the use of any simulated data. Using this principle, the data reported in Tables 3, 5, 7, 9, 11, 14 and 16 displays an improved error rate and message throughput rate from their respective counterparts.

### **6.5.3 Star Topology (Body-Worn Antenna) Demonstration Results**

The high error rate for GUID 6666, node 7, as exemplified in Table 12 and Table 13, was attributed to the instructor forwarding node 7's data packet to the repeater node. The repeater node would consistently receive the forwarded data packet from the instructor as an error. Since the repeater node received it as an error, it did not subsequently route the data packet to its parent, the TOC node, which resulted in a high packet error rate for node 7. The error rates for GUID 2222, node 5 and GUID 9999, node 8, were from the same issue.

In the following demonstration for the star topology, where nodes mounted rubber duck antennas on their radio units, the phenomenon was more prominent across all the nodes, for when the instructor forwarded its children's data packets to the repeater node. Table 14 and Table 15 exemplify the errors encountered through the 5-minute data collection of the star topology with the rubber duck antennas.

As presented in Figure 53 (image on the left), the distance of the TOC from the repeater and the instructor and its squad was 460 meters. The TOC node and repeater node remained stationary during

the whole duration of Demonstration 4. The high power R.F. power amplifier (PA) was enabled between the TOC node and repeater node only, during the full extent of Demonstration 4.



Figure 53. Illustrations of Star Topology (Body-worn Antenna) Demonstration

The message throughput rate for the instructor and the five trainee nodes were handicapped by the distance of 460 meters between the TOC and end-nodes. Taking into account the distance between the nodes and the TOC, primarily only routed messages emanating from the repeater node were being received by the TOC radio, during the star topology exercises (body-worn antenna and rubber duck antenna).

Depending on the locations of the end-nodes and based on the demonstration test activity, coupled with the distance of the end-nodes relative to the TOC node, the TOC was able to receive un-routed data packets directly from the nodes. But mostly, the message throughput rate and packet error rate were equivalent.

The problem wherein the repeater was receiving a large number of errors for data packets forwarded by the instructor warrants further investigation and the execution of well formulated set of tests in the laboratory and in the field to determine the fundamental of the problem.

As will be discussed in detail in Section 6.5.5 *Linear Topology (Rubber-ducky Antenna) Demonstration Results*, of this report, the issue where the repeater node was receiving an immense number of the instructor's forwarded data packets as errors was not present. The linear topology causes the greatest amount of packet-traffic because of the retransmissions required by the multi-hop link used to convey information from the originating node to the Instructor-node, repeater node and TOC node. For this anomaly not to present itself during the linear topology was unexpected.

Another oddity was that this issue did not seem to affect the forwarded data packets for the instructor and GUID 3333, node 4. As displayed in Table 12, Table 13, Table 14 and Table 15, the packet error rates for the 2 nodes were perfect.

For Official Use Only (FOUO)

Table 12. Packet Error and Message Rate - Star Topology, Body-Worn Antenna, 30-second period

NODE	Parent slot	Anticipated Routed Packet Receptions	Error Count	Packet error rate (PER) in %	Anticipated Packet Receptions (Un-routed/Routed)	Message Throughput Rate in %
GUID 8888, Repeater	1	10	0	0	10	100
GUID 1111, Instructor	2	10	0	0	10	100
GUID 3333, node 4	3	10	0	0	10	100
GUID 2222, node 5	3	10	1	10	9	90
GUID 7777, node 6	3	10	0	0	10	100
GUID 6666, node 7	3	10	7	70	4	40
GUID 9999, node 8	3	10	1	1	9	90

Table 13. Packet Error and Message Rate - Star Topology, Body-Worn Antenna, 1-minute period

NODE	Parent slot	Anticipated Routed Packet Receptions	Error Count	Packet error rate (PER) in %	Anticipated Packet Receptions (Un-routed/Routed)	Message Throughput Rate in %
GUID 8888, Repeater	1	5	0	0	5	100
GUID 1111, Instructor	2	5	0	0	5	100
GUID 3333, node 4	3	5	0	0	5	100
GUID 2222, node 5	3	5	0	0	5	100
GUID 7777, node 6	3	5	0	0	5	100
GUID 6666, node 7	3	5	2	40	4	80
GUID 9999, node 8	3	5	0	0	5	100

Figure 53 and Figure 54 depict the full range views of the star topology demonstrations. The image on the left represents the positions and distance between the TOC node and repeater node. The image on the right represents an expanded view of the star topology and the distance of the instructor relative to its parent, the repeater node, and between the instructor and the 5 trainee nodes.

#### 6.5.4 Star Topology (Rubber-ducky Antenna) Demonstration Results

As discussed thoroughly in the previous section (Section 6.5.2), all the errors experienced during this portion of the demonstration, which are listed in Table 14 and Table 15, are all contributed to the instructor forwarding its children's data packets, at their respective time slots, to the repeater node and the repeater node receiving the forwarded packets as errors.

Due in part to a closer distance of the trainee nodes to the TOC node, the TOC was able to receive un-routed packets either directly from the trainee nodes or the instructor's forward of the trainee node's packets to the repeater. It recouped the message throughput rate levels of the afflicted nodes to improved levels than that of the PER.

**Table 14. Packet Error and Message Rate - Star Topology, Rubber-ducky Antenna, 30-second period**

NODE	Parent slot	Anticipated Routed Packet Receptions	Error Count	Packet error rate (PER) in %	Anticipated Packet Receptions (Un-routed/Routed)	Message Throughput Rate in %
GUID 8888, Repeater	1	10	0	0	10	100
GUID 1111, Instructor	2	10	0	0	10	100
GUID 3333, node 4	3	10	0	0	10	100
GUID 2222, node 5	3	10	6	60	6	60
GUID 7777, node 6	3	10	5	50	7	70
GUID 6666, node 7	3	10	5	50	8	80
GUID 9999, node 8	3	10	5	50	8	80

**Table 15. Packet Error and Message Rate - Star Topology, Rubber-ducky Antenna, 1-minute period**

NODE	Parent slot	Anticipated Routed Packet Receptions	Error Count	Packet error rate (PER) in %	Anticipated Packet Receptions (Un-routed/Routed)	Message Throughput Rate in %
GUID 8888, Repeater	1	5	0	0	5	100

GUID 1111, Instructor	2	5	0	0	5	100
GUID 3333, node 4	3	5	0	0	5	100
GUID 2222, node 5	3	5	2	40	4	80
GUID 7777, node 6	3	5	1	20	4	80
GUID 6666, node 7	3	5	1	20	5	100
GUID 9999, node 8	3	5	1	20	4	80

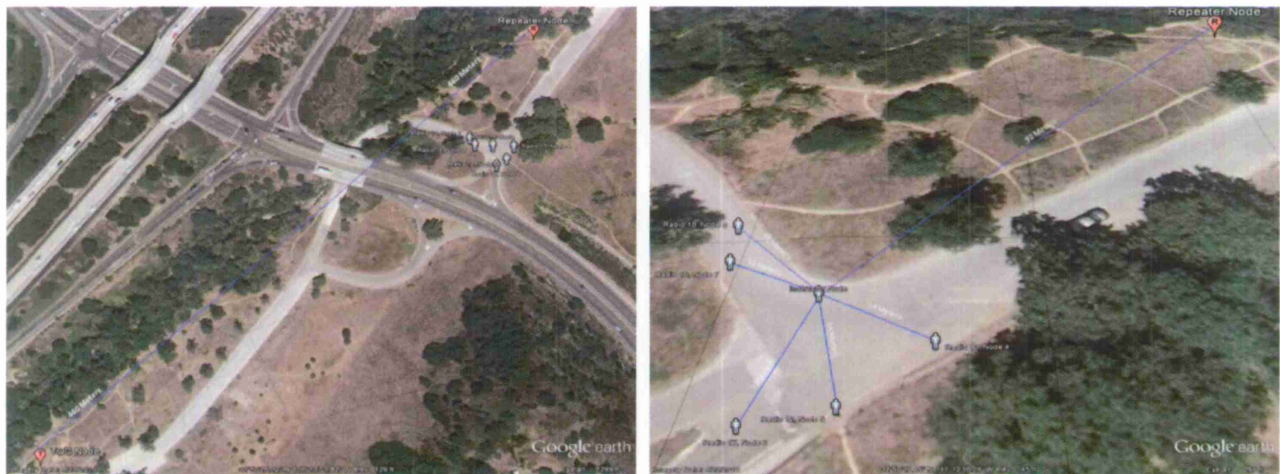

Figure 54. Illustrations of Star Topology (Rubber-duck Antenna) Demonstration

### 6.5.5 Supplementary Range Demonstration

Following the star topology rubber duck antenna demonstration, a range test was conducted to show the advancement of the radio performance. One member of the squad, GUID 9999, node 8, walked to extend its range to the instructor with the intention of demonstrating that single-link communication exceeds the 500-meter target set in the PWS. The instructor and node 8 activated their high power R.F. PA for this exercise. The remaining four nodes in the squad continued to operate with the low power R.F. PA. Node 8 proceeded to the east range test position on the southern hillside, east of Regents Road, while the instructor, accompanied by the remaining members of the squad walked briskly to the east facing wall of the west side bathroom (near the TOC location). Ultimately, the separation range between the instructor and the most-distant trainee was 930 meters. Once the distance was reached, the instructor and the rest of the squad, including node 8 stood in position for 5 minutes for data collection to determine PER and message throughput rate. It is important to note that, in previous testing distances in excess of 1000 meters were demonstrated. It is also important to note that in both cases (930-meters and 1000+ meters) the links were not line-of-site and included transmission through forested area. Under actual line-of-sight conditions, greater ranges can be anticipated, meeting or exceeding the PWS objective range of 1000 meters.

For Official Use Only (FOUO)

Table 16 and Table 17 represent the PER and message throughput rate from the moment the instructor and node 8 activated their high power R.F. PA's. It illustrates the overall error rates for the individual nodes as they migrated to their intended destination to achieve a range 930 meters. Some of the errors accounted for in Table 16 and Table 17 were from the issue of the repeater receiving the instructor's forward of its children's data packets as errors. In the case of node 6 and node 7, the distance between node 7 and its parent, the instructor, was at 236 meters, as illustrated in Figure 55. During this time, node 6 had registered with node 5 and finally with node 7. The distance of node 6 from the instructor was at 285 meters. This may account for the errors experienced for nodes 6 and node 7, as their distance to the instructor was too considerable and the instructor was not able to properly receive their individual or forwarded packets. The instructor also registered with the TOC node during this time.

**Table 16. Packet Error and Message Rate – Range Demonstration, 30-second period**

NODE	Parent slot	Anticipated Routed Packet Receptions	Error Count	Packet error rate (PER) in %	Anticipated Packet Receptions (Un-routed/Routed)	Message Throughput Rate in %
GUID 8888, Repeater	1	24	0	0	24	100
GUID 1111, Instructor	2/1	24	0	0	24	100
GUID 3333, node 4	3	24	1	4.2	23	95.8
GUID 2222, node 5	3	24	3	12.5	23	95.8
GUID 7777, node 6	3/5/7	24	4	16.6	24	100
GUID 6666, node 7	3	24	3	12.5	23	95.8
GUID 9999, node 8	3	24	1	4.2	24	100

**Table 17. Packet Error and Message Rate – Range Demonstration, 1-minute period**

NODE	Parent slot	Anticipated Routed Packet Receptions	Error Count	Packet error rate (PER) in %	Anticipated Packet Receptions (Un-routed/Routed)	Message Throughput Rate in %
GUID 8888, Repeater	0	12	0	0	12	100
GUID 1111, Instructor	2/1	12	0	0	12	100
GUID 3333, node 4	3	12	0	0	12	100

GUID 2222, node 5	3	12	1	8.3	12	100
GUID 7777, node 6	3/5/7	12	1	8.3	12	100
GUID 6666, node 7	3	12	0	0	12	100
GUID 9999, node 8	3	12	0	0	12	100



Figure 55. Illustration of Range Demonstration, 706 Meters

Table 18, Table 19 and Figure 56 represent the final destination of the instructor, its accompanying four trainee nodes and node 8. The maximum distance reached was at 930 meters as depicted on Figure 56. The tables illustrate the 5-minute data collection period to conclude the PER and message throughput rate for this distance. The high error rate for GUID 6666, node 7 was due to its link with the instructor, as was discussed in the previous paragraph. When node 7 would transmit its data packet to its parent, the instructor, the instructor intermittently did not receive it. The distance between the instructor and node 7 was approximately 210 meters. At the conclusion of the 5-minute data collection, the instructor and node 8 returned to low-power R.F. PA operation. The instructor and its accompanying trainee nodes made their way towards the repeater in order to perform the next demonstration, linear topology.

For Official Use Only (FOUO)

Table 18. Packet Error and Message Rate – Range Demonstration, 5-minute Data Collection, 30-second period

NODE	Parent slot	Anticipated Routed Packet Receptions	Error Count	Packet error rate (PER) in %	Anticipated Packet Receptions (Un-routed/Routed)	Message Throughput Rate in %
GUID 8888, Repeater	1	10	0	0	10	100
GUID 1111, Instructor	1	10	0	0	10	100
GUID 3333, node 4	3	10	0	0	10	100
GUID 2222, node 5	3	10	0	0	10	100
GUID 7777, node 6	3	10	1	10	10	100
GUID 6666, node 7	7	10	6	60	10	100
GUID 9999, node 8	3	10	1	10	10	100

Table 19. Packet Error and Message Rate – Range Demonstration, 5-min. Data Collection, 1-minute period

NODE	Parent slot	Anticipated Routed Packet Receptions	Error Count	Packet error rate (PER) in %	Anticipated Packet Receptions (Un-routed/Routed)	Message Throughput Rate in %
GUID 8888, Repeater	1	5	0	0	5	100
GUID 1111, Instructor	1	5	0	0	5	100
GUID 3333, node 4	3	5	0	0	5	100
GUID 2222, node 5	3	5	0	0	5	100
GUID 7777, node 6	3	5	0	0	5	100
GUID 6666, node 7	7	5	1	20	5	100
GUID 9999, node 8	3	5	0	0	5	100

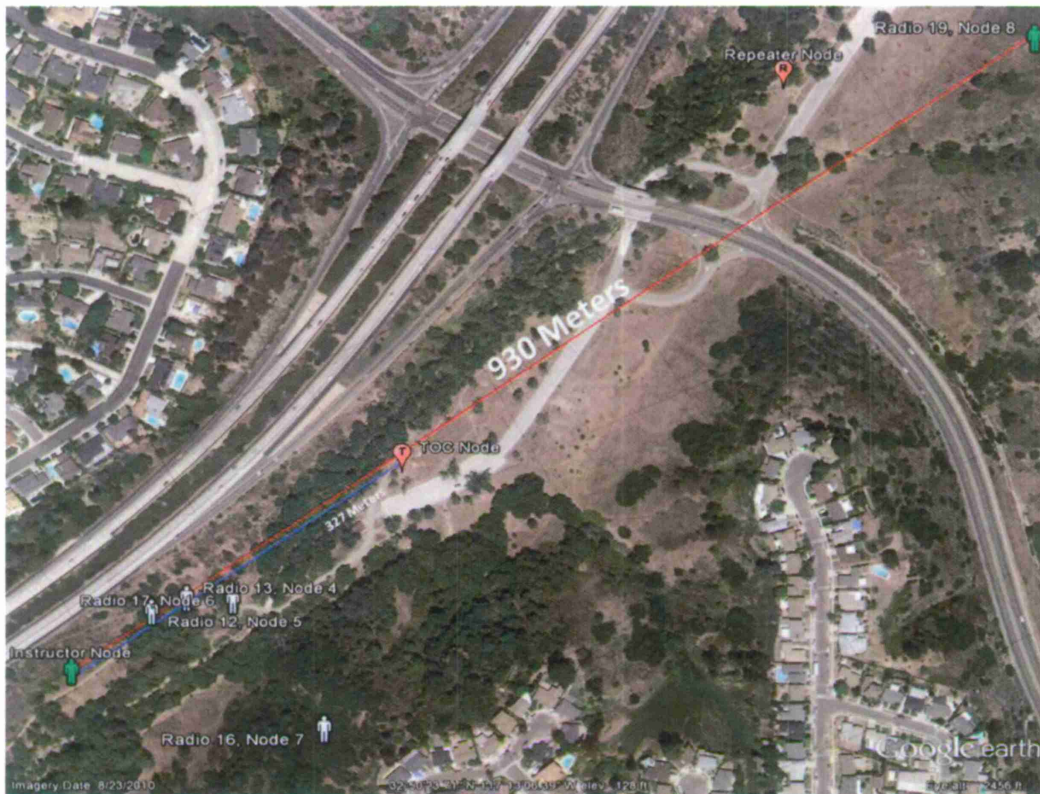

Figure 56. Illustration of Range Demonstration, 930 Meters

### 6.5.6 Linear Topology (Rubber-ducky Antenna) Demonstration Results

In this demonstration, the Instructor node and five trainee nodes took positions as necessary to form a linear topology that was linked, via the Instructor node, to the Repeater node and to the TOC node. Rubber-ducky antenna units were mounted on the Instructor node and trainee nodes. The instructor node and student nodes were fitted with 10dB fixed attenuators for the duration of the linear topology demonstration. This was to provide better control over the field-strengths when attempting to form the linear topology, reducing ranges to manageable levels.

The errors for GUID 7777, node 6 and GUID 6666, node 7, were due to the link quality between node 6 and its parent, GUID 2222, node 5. The distance between node 5 and node 6 was approximately 59 meters. Reception by the parent node (node 5) of data packets from GUID 7777, node 6 (a child of the parent) and data packet from GUID 6666, node 7 (grandchild of the parent) were intermittently declared as being too degraded for proper reception. Since node 5 was not able to properly decode the packet, it was not propagated through the linear topology to be routed to the TOC and resulted in a “routed” packet error.

Once the linear topology was formed, an attempt was made to move the distance gap closer between all the trainee nodes to eliminate any poor link-quality between the nodes. The pursuit was discarded as nodes began moving closer to their already established parent, some nodes hopped registration and the network was no longer in the linear topology. This is simply the mechanics of forcing a linear topology to occur in the field. Additional field testing and stringent practices of the formation of the linear topology can correct the link problem experienced between some of the nodes.

For Official Use Only (FOUO)

The phenomenon where the repeater would receive the forwarded data packets of the instructor's children at a high error rate was not present during the linear topology demonstration.

**Table 20. Packet Error and Message Rate – Linear Topology, 30-second period**

NODE	Parent slot	Anticipated Routed Packet Receptions	Error Count	Packet error rate (PER) in %	Anticipated Packet Receptions (Un-routed/Routed)	Message Throughput Rate in %
GUID 8888, Repeater	1	10	0	0	10	100
GUID 1111, Instructor	2	10	0	0	10	100
GUID 3333, node 4	3	10	0	0	10	100
GUID 2222, node 5	3	10	0	0	10	100
GUID 7777, node 6	5	10	3	30	7	70
GUID 6666, node 7	6	10	3	30	7	70
GUID 9999, node 8	7	10	1	10	9	90

**Table 21. Packet Error and Message Rate – Linear Topology, 1-minute period**

NODE	Parent slot	Anticipated Routed Packet Receptions	Error Count	Packet error rate (PER) in %	Anticipated Packet Receptions (Un-routed/Routed)	Message Throughput Rate in %
GUID 8888, Repeater	1	5	0	0	5	100
GUID 1111, Instructor	2	5	0	0	5	100
GUID 3333, node 4	3	5	0	0	5	100
GUID 2222, node 5	4	5	0	0	5	100
GUID 7777, node 6	5	5	0	0	5	100
GUID 6666, node 7	6	5	1	20	4	80
GUID 9999, node 8	7	5	0	0	5	100



Figure 57. Illustration of Linear, 5-Hop Topology Demonstration

### 6.5.7 Bi-directional Messaging Separation-case and New Features Advancement

In the following test, it was demonstrated that the current embodiment of the SPARNET system has the capability of supporting two squads, operating from a single TOC and auto-configured using a single, R.F. frequency. Because of limitations on the number of radios, each squad consisted of one instructor and two students.

At the onset of the test, a member of the customer's group and the test director accompanied node 6 through the complete process of the exercise. GUID 9999, node 8 remained powered-off during this part of the demonstration. GUID 5555, the second instructor, to be used for Squad #2, was enabled and appropriate actions were taken in order to configure GUID 5555 in the network layer and assume the slot assignment of GUID 9999. In short, GUID 5555 was now in slot 8, the slot vacated by GUID 9999. The TOC operator constructed the applicable modifications to the control message in order to deactivate GUID 9999 and to allow GUID 5555 in the exercise and assembled the appropriate trainee nodes in their rightful squads. Below was how the 2 squads were constructed for the exercise.

#### *Squad #1*

*GUID 1111, node 3 - instructor*

*GUID 3333, node 4 – trainee node*

*GUID 2222, NODE 5 – trainee node*

#### *Squad #2*

*GUID 5555, node 8 – instructor*  
*GUID 6666, node 7 – trainee node*  
*GUID 7777, node 6 – trainee node*

During the execution of this demonstration, one squad was positioned in the woods, west of the bathroom that was close to the TOC (Squad #1, network id 1). The second squad (Squad #2, network id 2) remained on the west side of Regents Road, nearby the repeater. A designated trainee-node, GUID 7777, node 6, from the Regents Road squad (Squad #2) was directed to initiate a 911-alert, which occurred at 21:00:00, and began walking away from its squad toward Squad #1. The TOC was directed not to acknowledge the trainee's 911-alert. Once node 6 walked sufficiently far from Squad #2, it auto-disconnected from the network and initiated "broadcast mode" (see Figure 59), making its energy detectable by any radio-units that are within range. Node 6 deregistered from the network and began storing its data packets at 21:02:48. Once in broadcast mode (separated from its squad) the TOC was commanded by the test director to transmit an acknowledgement to the alerting-radio of the 911 alert.

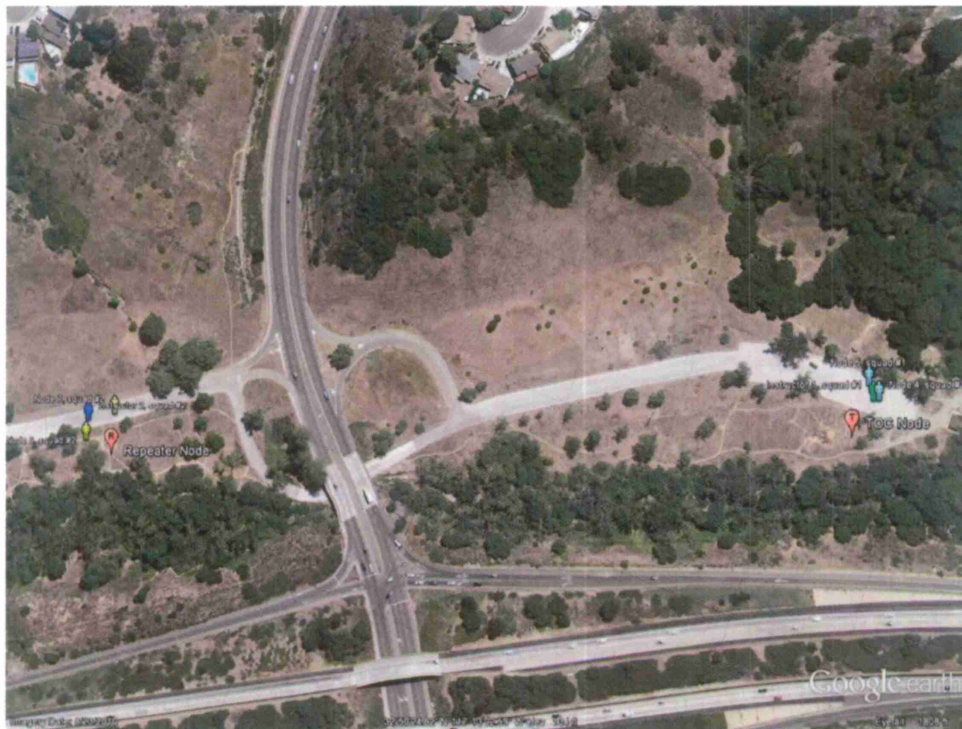

Figure 58. Illustration of 2 instructor-led training squads



Figure 59. Illustration of node 6's migration towards squad #1, and subsequent off-network event

If the radio is within range of the TOC, its assigned squad or a repeater, the acknowledgement will be received and will be displayed as "911=ACK" on the LCD of its radio. This does not mean that it has been connected back onto the network, only that the network has identified its position and is acknowledging its 911-alert.

Figure 58 exemplifies the placements of the two instructor-led training squads. Squad #1 instructor (green colored icon, children in light blue colored icons) was registered with the TOC and squad #2 instructor (blue colored icon, children in yellow colored icons) was registered with the repeater.

Figure 59 depicts node 6's journey towards the TOC and Squad #1 and the stations of the two instructor-led squads. At 166 meters distance from its starting position, node 6 was still connected to the network through its parent (at the time of this snapshot), node 7. The red colored icon represents node 6 as off-network and broadcasting its data packet, with a distance of 329 meters from Squad #2 and 144 meters from the TOC node.

In the case that was demonstrated, the alerting node was within range of the TOC and received a "911=ACK" message from the TOC node, as symbolized in Figure 59. Node 6 received the ACK from the TOC on 21:19:38. Subsequently, the TOC, knowing the location of the trainee node, configured the control message to include the off-net trainee in Squad #1. This message was transmitted to and received by the Squad #1 instructor. The Squad #1 instructor caused the message to be propagated through its squad members. The off-net trainee recognized its radio ID number and that it was re-assigned to Squad #1. It proceeded to rejoin the network by registering with the instructor of the Squad #1 network-topology (see Figure 60), reestablishing full ability to communicate/direct it and to monitor any physiological or geo-location information of interest. Node 6 registered with the instructor at

21:21:18 and began transmitting its current and store-and-forward packets. Upon registration, node 6 depressed its push button to deactivate its 911 alert. Once confirmed by the Squad #1 instructor and TOC node, per their respective mapping applications, the TOC node commenced to transmit the message to node 6 that rendered a "911=OFF" message to be displayed on its radio LCD. This occurred on 21:21:50.

Node 6 was instructed to stand in place for a couple of minutes to ensure that it was reliably transmitting its current and store-and-forward data packets to its parent, the instructor and from the instructor to the TOC. A decision was made by the customer to terminate the test and to not consume additional time in allowing node 6 to fully expel all of its store-and-forward data packets remaining in its buffer since the store-and-forward functionality had already been demonstrated during the early stage of Demonstration 4 and validated in previous demonstrations.

In total, this demonstration exercised bi-directional communication between the off-net trainee and TOC node, illustrated that an off-node radio will receive a message that is sent to it when it is within range of appropriate network resources and can be commanded to rejoin a new network. Further, it is the case that Squad #1 could have been used to discover the location of the off-net soldier, had not the TOC resources been more immediately available. That is, individual squads can be used as extensions of the network to search for, and recover, off-net personnel, as required.



Figure 60. Illustration of node 6's registration with squad #1 instructor

### 6.5.8 Overall Packet-Error-Rate (PER) and Message Throughput Rate for Full Duration of Demonstration 4

Table 22 and Table 23 illustrate the overall PER and message throughput rate for the 3 hour duration of Demonstration 4 functionalities. The PER is an aggregate of issues the individual nodes experienced, which have been noted in this report.

GUID 9999's number of anticipated routed packet receptions is lower than its counterparts since it was powered off during the bi-directional separation-case demonstration as discussed in Section 6.5.6. In its place, GUID 5555 was enabled to be utilized as a second instructor for Squad #2. The period of 9 minutes after the execution of the range test, as discussed in Section 6.5.4, was not considered in the calculation for Table 22 and Table 23. Both the instructor and GUID 9999, node 8 deactivated their high power R.F. power amplifier and enabled their low power R.F. power amplifier at the completion of the data collection. With the distances achieved during the range test, the nodes reverting back to the use of their low power R.F. power amplifier caused the TOC to not properly receive the nodes' transmitted data packets. 9 minutes was the time it took for the instructor and its accompanying squad to return to the eastern side of the park, near the repeater, in order to demonstrate the linear topology.

The 21 minutes of time invested in demonstrating the bi-directional messaging separation case, as summarized in Section 6.5.6 of this report, was not calculated for GUID 7777, node 6. The notion was that node 6, while off-network, broadcasting its data and ultimately storing its off-network data packets in its store-and-forward buffer, was not allotted time to fully transmit the store-and-forward data packets in its queue once it rejoined the network and registered with the instructor of Squad #1. It would be unjust to calculate this data for node 6 considering that it was not able to dispatch all of the packets in its store-and-forward queue that would have recouped the full span of its missing data for the time it was off-network. Otherwise, the 41 data packets missing for node 6 would count as errors.

**Table 22. Overall calculation of error rates for full duration of Demonstration 4, 30-second period**

Nodes	Duration (Approximately 3 hrs)	Anticipated Routed Packet Receptions	Error Count	Packet error rate (PER) in %	Anticipated Packet Receptions (Un- routed/Routed)	Message Throughput Rate in %
GUID 8888, Repeater	18:32:34 21:23:04	259	0	0	259	100
GUID 1111, Instructor (1)	18:32:38 21:23:08	259	1	0.4	258	99.6
GUID 5555, Instructor (2)	20:20:56 21:22:56	54	10	18.5	44	81.5
GUID 3333, node 4	18:32:40 21:23:10	259	6	2.3	254	98
GUID 2222, node 5	18:32:44 21:23:14	259	19	7.3	245	94.6
GUID 7777, node 6	18:32:48 21:02:18	217	24	11	201	92.7

GUID 6666, node 7	18:32:52 21:22:52	258	26	10	233	90.3
GUID 9999, node 8	18:32:56 20:29:26	205	28	13.7	185	90.2

**Table 23. Overall calculation of error rates for full duration of demonstration, 1-minute period**

<b>Nodes</b>	<b>Duration (Approximately 3 hrs)</b>	<b>Anticipated Routed Packet Receptions</b>	<b>Error Count</b>	<b>Packet error rate (PER) in %</b>	<b>Anticipated Packet Receptions (Un- routed/Routed)</b>	<b>Message Throughput Rate in %</b>
GUID 8888, Repeater	18:32:34 21:23:04	132	0	0	132	100
GUID 1111, Instructor (1)	18:32:38 21:23:08	132	0	0	132	100
GUID 5555, Instructor (2)	20:20:56 21:22:56	27	3	11.1	24	88.9
GUID 3333, node 4	18:32:40 21:23:10	132	1	0.8	131	99.2
GUID 2222, node 5	18:32:44 21:23:14	132	0	3.8	130	98.5
GUID 7777, node 6	18:32:48 21:02:18	111	4	3.6	110	99.1
GUID 6666, node 7	18:32:52 21:22:52	130	7	5.4	126	96.9
GUID 9999, node 8	18:32:56 20:29:26	104	5	4.8	99	95.2

## 7 KEY RESEARCH ACCOMPLISHMENTS

Key accomplishments for the reported period include:

- Advancement of the purpose-built SPARNET SAN radio to satisfactory maturity levels.
- Increased range to achieve the target of 500 meters and illustrated a powerful and reliable system capable of bypassing the threshold range requirement and achieving the objective distance of 1000 meters (1km), as specified in the project work statement (PWS).
- Implementation of Bluetooth-enabled option-card and associated software development.
- Integrated physiologic status monitoring via the Bluetooth-link, an Option Year 1 task that was engineered to be demonstrated in the exhibition of Demonstrations 2-4.

## For Official Use Only (FOUO)

- Reporting of heart rate data on the network layer, TOC application and instructor mobile device.
- Optimization of the network layer to enable functionalities for the advancement of Option Year 1 functionalities: the formation of multi-squad and multi-instructor network by the operation of two Squads and recovery of an off-net student.
- Stabilization of the software defined radio algorithms.
- Modification of hybrid AGC architecture to operate on shorter sample-intervals. The addition of this AGC improved the number of errors experienced.
- Improved robustness/accuracy of calculation of signal-amplitude metrics used in AGC-control and as a metric for network formation.
- Significant advancements in the ability to capture and analyze signals and messages to facilitate acceleration of enhancement and debugging efforts
  - Concepts for capture/storage of live packets, based on error-messaging were developed
- Design and integration of a new managed network architecture in which the radios authorized to be within a squad can be pre-assigned a time-slot by the TOC.
- Bi-directional communication established between the TOC=>trainee node and between TOC=>instructor node.
- Integration of a repeater backbone layer to extend the range of the test venue.
- Integration of Handheld Speech's voice- and gesture-driven software application and handheld speech application on the instructor's map application.
- Incremental Improvements on the overall SPARNET system as validated on the scheduled four demonstrations.
- Storage, formatting and downloading of data stored on individual nodes via FLASH memory.
- Performance assessment software to facilitate the capture and storage of performance metrics were finished and tested.
- Bi-directional communication enabled between the TOC application/database and TOC radio node. This feature allows the TOC personnel to manage the training exercise and the squads and gateways contained therein.
- Ability for the TOC to configure the instructor's handheld unit with roster data information required for operation of the instructor's map application. The roster information contains the list of trainees, along with a time-slot assignment from a master list of available time-slot resources.

## For Official Use Only (FOUO)

- Integrated capability for the instructor's mapping application to send the roster data information it received from the TOC to the instructor's radio.
- Mapping Control, central to the TOC and Instructor handheld software applications, was advanced to provide a variety of new status indicators for each participant such as heart rate data, slot assignment, parent's slot assignment and topology shifts. Other enhancements include the calculation of distance and bearing from a student and its instructor and a ruler function to determine the distance between any two points on the map.
- Successfully integrated graphical user interface (GUI) into the TOC and Instructor handheld software applications that includes such features as enhanced management and configuration capabilities, visualization and analysis of received data, graphing/charting capability, display of time-series graphs of packet-error-rate, ability to recall old test data and meta-data, reporting and plotting of sensor data, improved alerting functionalities, and integration of Handheld Speech, a voice command application.

## 8 CONCLUSION

The Base Year objectives and requirements set forth in the Performance Work Statement (PWS) for U.S. Army contract number W911QY-11-C-0012, "Integrated Short Range, Low Bandwidth, Wearable Communications Networking Technologies" were demonstrated. Four field-demonstrations showed the incremental advancements accomplished on the SPARNET system over the course of the base year. Early-stage implementations of some Option-year objectives were successfully demonstrated to showcase the maturing nature of the network. Advancements made to the various elements of the SPARNET system were engineered to maintain the gracefully-adaptable architectures on which the system is based. Enhancements included a network layer that supports multiple instructors/squads, integration of voice-driven operation of the instructor's map application via software tools provided by Handheld Speech and heart-rate monitoring via a purpose-built, Bluetooth-enabled daughter board.

The range of technical issues that hindered rapid progress during earlier months in the project was overcome at an increasingly accelerating pace, as the contract-year advanced. As reflected in the performance shown and documented in the final (fourth) demonstration, the schedule was recovered and the performance objectives for Year 1 of the contract were achieved. In addition, early-stage implementations of features scheduled for Option Year 1 were also successfully demonstrated. These features included operation with more than one instructor/squad and recovery of an off-net trainee-node via search, discovery and registration through a previously-unassociated squad.

A range of new developmental work and work aimed at improving existing elements of the overall design were successfully undertaken. Examples of the work include: 1) improvements in CCA circuitry; 2) implementation of a digitally-controlled, two-stage, automatic-gain-control architecture to improve dynamic response; 3) incremental changes to the network-layer to support managed-network operation; 4) design, implementation and integration of a bi-directional, Bluetooth-enabled, daughter board and accompanying software to enable connectivity with commercially-available heart-monitors; 5) refinement and demonstration 911 alerts; 6) design, implementation and validation of bi-directional messaging capability; 6) refinement and demonstration of store-and-forward capabilities supporting network-separation scenarios; 7) enhancement of application software to provide managed-network capabilities including dynamic time-slot assignment/re-assignment, bi-directional messaging between

the TOC and instructor or TOC and trainees, and setting status/warning flags; 9) implementation and verification of code to permit bi-directional communication between the instructor's display and radio.

As the project progressed, significant advancements in the ability to capture and analyze signals and messages were made. Some tools were engineered to trigger on user-defined error-messages, produced by the operating code. Collectively, these utilities aided the engineering and debugging efforts, and the test, verification and demonstration activities that were executed to assure attainment of all performance-features and overall quality-levels, established for each performance-period.

The overarching objective of the project was successfully met. The SPARNET network was advanced to TRL 5/6, with a prototype system tested in a relevant environment, resulting in successful demonstration of the network, including early-stage implementations of some out-year features. The TRL of the current system-implementation showed clear advancement, over the course of the R&D effort, and is now positioned for refinement and reduction activities aimed at advancing the system to low-rate-initial-production status.