

REPORT DOCUMENTATION PAGE

Form Approved
OMB No. 0704-0188

The public reporting burden for this collection of information is estimated to average 1 hour per response, including the time for reviewing instructions, searching existing data sources, gathering and maintaining the data needed, and completing and reviewing the collection of information. Send comments regarding this burden estimate or any other aspect of this collection of information, including suggestions for reducing the burden, to Department of Defense, Washington Headquarters Services, Directorate for Information Operations and Reports (0704-0188), 1215 Jefferson Davis Highway, Suite 1204, Arlington, VA 22202-4302. Respondents should be aware that notwithstanding any other provision of law, no person shall be subject to any penalty for failing to comply with a collection of information if it does not display a currently valid OMB control number.

PLEASE DO NOT RETURN YOUR FORM TO THE ABOVE ADDRESS.

| | | | | | |
|--|-------------|------------------------------------|----------------------------|---|---|
| 1. REPORT DATE (DD-MM-YYYY) 16-04-2012 | | 2. REPORT TYPE Technical Report | | 3. DATES COVERED (From - To) 01-01-2009 - 30-08-2012 | |
| 4. TITLE AND SUBTITLE Vibration Energy Harvesting Concept using a Balanced Armature Transducer | | | | 5a. CONTRACT NUMBER Contract No. N00014-09-1-0386 | |
| | | | | 5b. GRANT NUMBER | |
| | | | | 5c. PROGRAM ELEMENT NUMBER | |
| 6. AUTHOR(S) Thompson, Stephen C. | | | | 5d. PROJECT NUMBER 16416 | |
| | | | | 5e. TASK NUMBER | |
| | | | | 5f. WORK UNIT NUMBER | |
| 7. PERFORMING ORGANIZATION NAME(S) AND ADDRESS(ES) The Pennsylvania State University The Applied Research Laboratory P.O. Box 30 State College, PA 16804 | | | | 8. PERFORMING ORGANIZATION REPORT NUMBER Technical Report No. TR-012-003 | |
| 9. SPONSORING/MONITORING AGENCY NAME(S) AND ADDRESS(ES) Office of Naval Research 875 North Randolph Street Arlington, VA 22203-1995 Attn: Jan Lindberg, ONR 321 | | | | 10. SPONSOR/MONITOR'S ACRONYM(S) ONR | |
| | | | | 11. SPONSOR/MONITOR'S REPORT NUMBER(S) | |
| 12. DISTRIBUTION/AVAILABILITY STATEMENT Approved for public release, distribution unlimited | | | | | |
| 13. SUPPLEMENTARY NOTES | | | | | |
| 14. ABSTRACT Balanced armature transducers are used as the speakers in most hearing aids and in some small insert earphones. In this size range, the balanced armature speaker is a more efficient audio generator than other technologies. This project has investigated the possibility of using these same or similar balanced armature devices in a reciprocal configuration as the generator for vibration energy harvesting. Earlier work by Vitt [Nikolas T. Vitt, "Investigation of a balanced-armature transducer for vibrational energy harvesting," M.S. thesis, Penn State University, 2011] has shown insufficient output if the device is mounted conventionally, but that a useful output of approximately 100-200 W/g could be available if the transducer were mounted by its armature. Of course, Vitt knew that mounting by the armature alone is unrealistic, but suggested that possibility as a best case estimate of the output that might be available from a more realistic mounting. This paper examines that possibility in more detail, and suggests a conceptual mounting configuration that can generate an output in the range suggested by Vitt for single frequency vibration input, with output perhaps as great as 1 mW over a wideband vibration source mounting layout (11). | | | | | |
| 15. SUBJECT TERMS Vibration, Energy Harvesting | | | | | |
| 16. SECURITY CLASSIFICATION OF: | | | 17. LIMITATION OF ABSTRACT | 18. NUMBER OF PAGES | 19a. NAME OF RESPONSIBLE PERSON |
| a. REPORT | b. ABSTRACT | c. THIS PAGE | | | Stephen C. Thompson |
| U | U | U | UU | 24 | 19b. TELEPHONE NUMBER (include area code) 814-865-1090 |

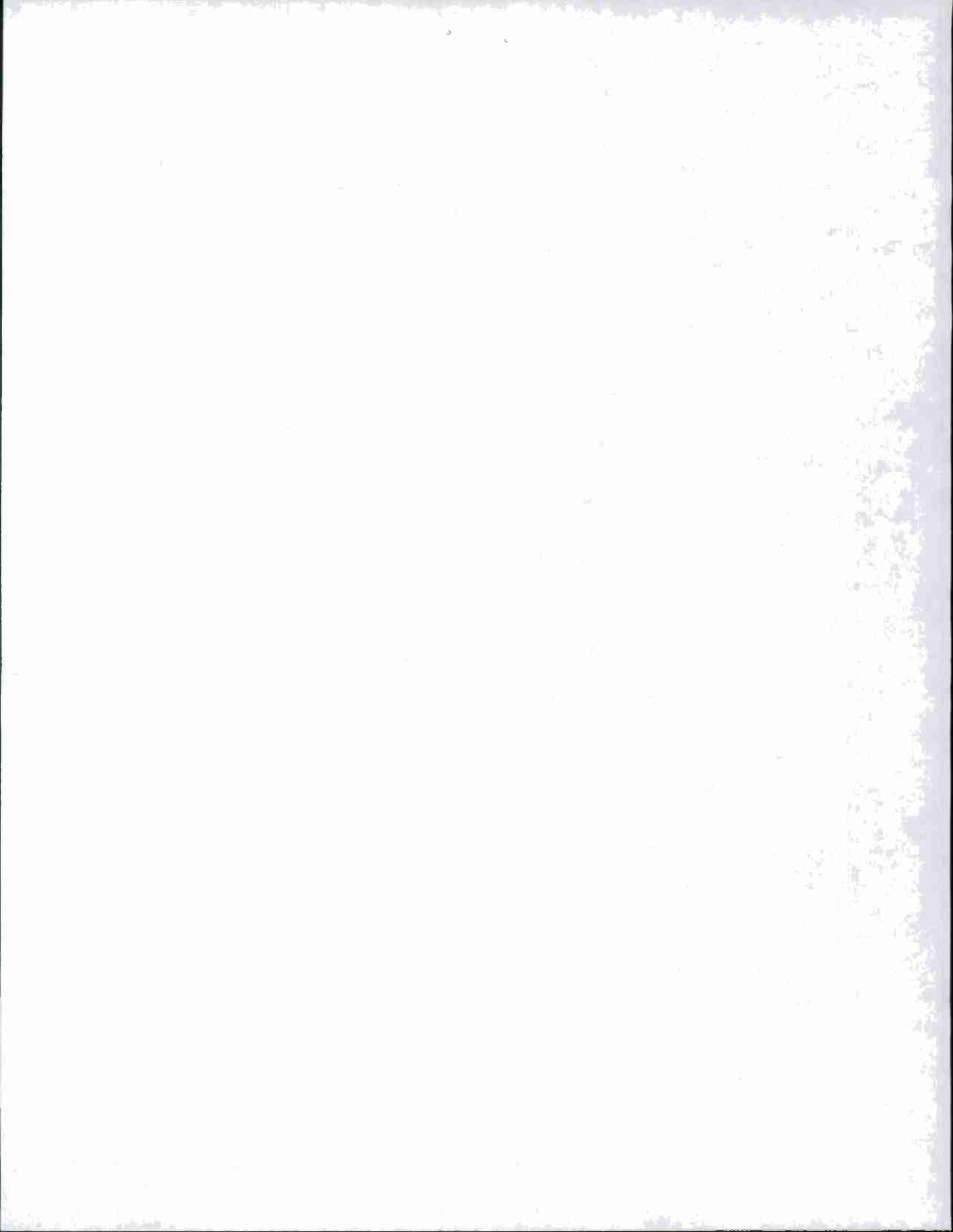

Applied Research Laboratory

Technical Report



PENNSYLVANIA STATE UNIVERSITY
PENNSTATE





The Pennsylvania State University
The Applied Research Laboratory
P.O. Box 30
State College, PA 16804

Vibration Energy Harvesting Concept
using a Balanced Armature Transducer

by
Stephen C. Thompson

Technical Report No. TR-012-003
April 16, 2012

Supported by:
Office of Naval Research Contract No. N00014-09-1-0386

Approved for public release, distribution unlimited

20120814027

This page intentionally left blank.

Abstract

Balanced armature transducers are used as the speakers in most hearing aids and in some small insert earphones. In this size range, the balanced armature speaker is a more efficient audio generator than other technologies. This project has investigated the possibility of using these same or similar balanced armature devices in a reciprocal configuration as the generator for vibration energy harvesting. Earlier work by Vitt [Nikolas T. Vitt, "Investigation of a balanced-armature transducer for vibrational energy harvesting," M.S. thesis, Penn State University, 2011] has shown insufficient output if the device is mounted conventionally, but that a useful output of approximately 100-200 $\mu\text{W}/\text{g}$ could be available if the transducer were mounted by its armature. Of course, Vitt knew that mounting by the armature alone is unrealistic, but suggested that possibility as a best case estimate of the output that might be available from a more realistic mounting. This paper examines that possibility in more detail, and suggests a conceptual mounting configuration that can generate an output in the range suggested by Vitt for single frequency vibration input, with output perhaps as great as 1 mW given a wideband vibration source providing 1 $\text{g}/\sqrt{\text{Hz}}$.

This page intentionally left blank.

Contents

| | | |
|---|-------------------------------|----|
| 1 | Introduction | 1 |
| 2 | The Mounting Concept | 2 |
| 3 | A Combined FEA/Analog Model | 3 |
| 4 | Available Output Power | 7 |
| 5 | Alternative Design Features | 8 |
| 6 | Caveats | 11 |
| 7 | Suggestions for Further Study | 12 |

This page intentionally left blank.

List of Figures

| | | |
|----------|--|----|
| Figure 1 | Preliminary concept sketch showing modifications transducer. | 2 |
| Figure 2 | Concept sketch of the suggested transducer mounting. | 3 |
| Figure 3 | Complete analog model for a single DOF mechanical system. | 4 |
| Figure 4 | Analog model of the balanced armature transducer, excluding most of the mechanical domain. | 4 |
| Figure 5 | Analog circuit current drive methodology to assure a linear model. | 6 |
| Figure 6 | Rocking vibration mode of the transducer on its mounting springs. | 7 |
| Figure 7 | Translational vibration mode of the transducer on its mounting springs. | 8 |
| Figure 8 | Electrical output power for a 1 g acceleration input at the mounting plate. | 9 |
| Figure 9 | Electrical output power for 1 g acceleration input for the two cases of stress rod attachment. | 10 |

This page intentionally left blank.

Acknowledgments

This material is based upon work supported by the Office of Naval Research through the Naval Sea Systems Command under contract No. N00014-09-1-0386. Any opinions, findings and conclusions, or recommendations expressed in this material are those of the author and do not necessarily reflect the views of the Office of Naval Research or the Naval Sea Systems Command.

This page intentionally left blank.

1 Introduction

The balanced armature transducer structure[1] is used in the miniature acoustic speakers for hearing aids and insert earphones. It was investigated by Vitt [2] for use as an electrical energy generator using ambient vibration as the energy source. The specific transducer used in that study was the Knowles Electronics CI-28409. The Knowles CI family of transducers has the highest available maximum acoustic output of any balanced armature device currently in production, and might be a good choice for an energy generator.

The Vitt work used a linear transducer model provided by Knowles that is known to be accurate in predicting electroacoustic performance of the device. That model was modified to include the calculation of the vibration sensitivity. Vitt verified the model measurement of several sample units, and then used it to estimate the improvement in vibration sensitivity that might be achieved by several simple modifications to the design of the transducer. The best case of the options examined was to eliminate the diaphragm and thus the impedance of the front volume and acoustic port, and to directly drive the armature from the vibrating source, with the mass of the transducer and its case suspended by the stiffness of the armature. Of course, this is known to be an inadequate solution for generator mounting, and was used only as a "best case" estimate of the sensitivity that might be achieved with a more practical mounting arrangement that could later be devised. This report carries that concept forward to suggest a more realistic generator mounting concept and to calculate the power generation capability of the CI transducer.

Note that the vibration sensitivity that is calculated by Vitt assumes that the transducer is sensitive only to linear motion in the direction normal to the magnetic gap. That assumption is also used in the present work. Balanced armature transducers are known to also be sensitive to vibration in the other directions and especially to rotations around at least one axis. The author believes it is safe to neglect these additional sensitivities because they are expected to be relatively small, and they are likely to increase the total energy generated by the device by only a small amount.

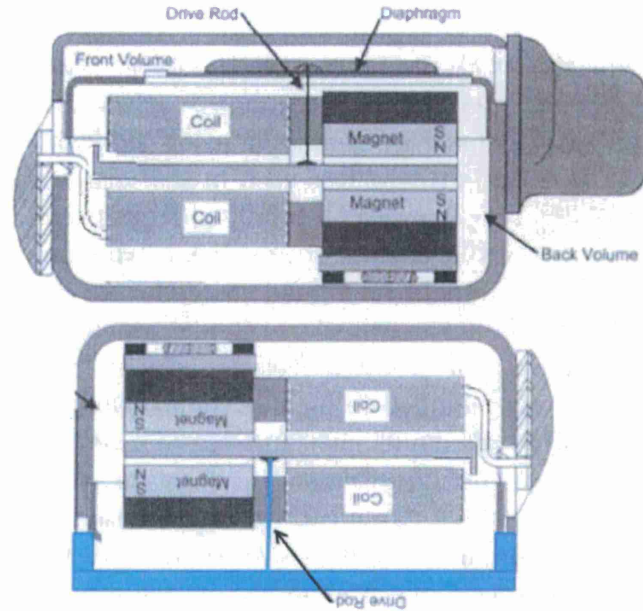

Figure 1: Top: A conventional balanced armature transducer similar to the CI-28409. Bottom: (shown inverted compared to top) Modifications suggested for the energy harvesting application.

2 The Mounting Concept

The transducer modifications and mounting concept are shown in Figure 1. Changes to the CI-28904 include elimination of the diaphragm, replacement of the cover by a mounting plate and compliant ring (blue pieces in the figure), and the attachment of the drive rod to the inside of this new mounting plate. The transducer is attached to the vibrating surface by the new cover, so that the mass of the transducer body moves on the compliance of the cover.

A more realistic implementation of this mounting is shown in Figure 2. The balanced armature transducer is rigidly attached to a top plate and suspended above the mounting place by at least two mounting springs as shown. The drive rod extends from the transducer down to the mounting plate, so that the relative motion of the transducer and mounting plate drives the armature to produce the electrical output.

This structure will support multiple useful and other possibly extrane-

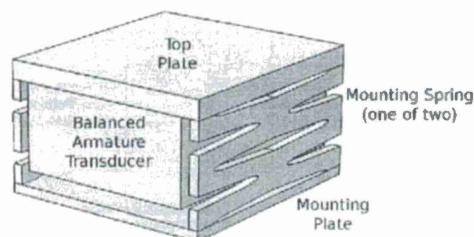

Figure 2: More realistic concept with the balanced armature transducer mounted from a top plate with the drive rod protruding from the bottom in the figure, and with compliant mounting springs on two or four sides to support the mass.

ous vibration modes that must be considered. Consequently, the vibration analysis is best done with a finite element analysis code such as COMSOL Multiphysics. The structure is intended to have its dominant resonances in the region below 500 Hz, as this is a range in which ambient vibration is often encountered. For particular applications, it may be desirable to match the a resonance frequency of the device to the frequency of a dominant source vibration. Often, however, the source is broadband or its dominant frequencies are not known.

The distributed nature of the masses and springs allows several modes of vibration that may each be useful for the application. The design objective would be for at least one, and possibly two or more of these resonance frequencies to be in the operating range of the vibration generator to enhance the sensitivity at each of the resonances.

3 A Combined FEA/Analog Model

A reasonably simple model of the generator needs to include the multi-resonant vibration behavior of the device and requires a finite element analysis model. However the transduction behavior of the transducer is adequately modeled using analog electrical circuit methods. For this application it is possible to use the electrical circuit modeling capabilities of the COMSOL AC/DC Module for the analog modeling, and to couple the transduction behavior from the analog model to the finite element model of the vibrating structure of Figure 2.

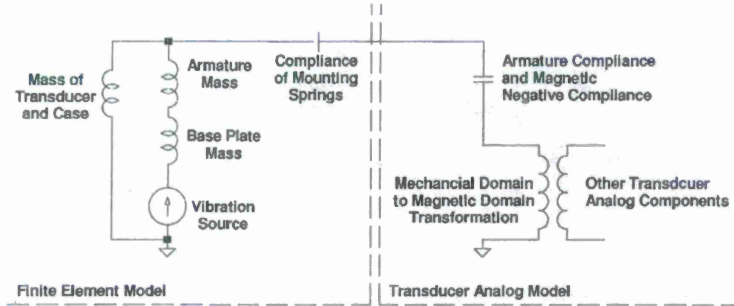

Figure 3: Complete analog model for a single DOF mechanical system.

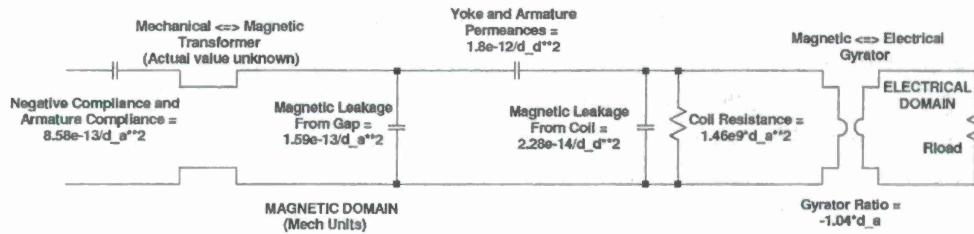

Figure 4: Analog model of the balanced armature transducer, excluding most of the mechanical domain.

A complete analog model for the full system as described by Vitt[2] is shown in Figure 3. The assumptions are that the mechanical system vibrates with only a single degree of freedom, and that the drive rod makes a rigid connection between the base plate and the armature. The first assumption will later be removed when the finite element model replaces the analog model for the mechanical system. The second assumption remains in the present work, but will need further consideration before proceeding to a prototype.

The details of the transducer analog model were defined by Vitt [2], and the analog is shown in Figure 4. Briefly, this model starts as a copy of the one provided by Knowles that models only the electroacoustic behavior of the transducer. The Knowles model uses acoustical units for all components, and does not include the vibration path components. Vitt approximated a value for the diaphragm area of the device that allowed the transformation of the

components to the mechanical domain and facilitated the addition of the vibration path to the model. The results of this transformation are shown in the figure as the component values all include the factor d_a , the area of the diaphragm. The present analysis has also ignored the eddy current impedance component, because the vibration frequency range is generally below the critical frequency for eddy currents.

The finite element mechanical model treats the transducer as a rectangular box having a uniform mass density that provides the correct transducer mass. The top plate is steel somewhat thicker than necessary for rigidity, so that it adds mass to reduce the resonance frequency. The mounting springs are made from the COMSOL standard Nylon material, although many plastics could be used with little difference in performance. The Young's modulus for the spring is given a complex value to add reasonable damping to the vibration. The value of this loss coefficient is arbitrarily selected as 0.1 with the expectation that real materials with greater or less damping can be found as desired.

The coupling of the FEA mechanical model to the analog circuit model takes place at the physical location of the drive rod connecting the transducer armature to the base plate. In the physical hardware, a rigid drive rod connects the armature to the base plate and assures that their velocities are the same. Thus the *relative velocity* of the armature in its magnetic gap is the difference in velocities between the transducer case and the base plate. The FEA mechanical model calculates this relative velocity. The value of that velocity is used to set the input current (analogous to velocity) in the analog model. The circuit model calculates the electrical output voltage and current as well as the driving point reaction force (analogous to circuit voltage) of the transducer armature back on the drive rod. This force is added back into the mechanical model as a mechanical point load at the drive rod mounting position. This two-way coupling allows the armature stiffness and the magnetic negative compliance that are included in the analog model to influence the resonance frequencies of the FEA model.

The model described above was implemented in version 4.2a of the COMSOL Multiphysics code. Most aspects of the implementation are straightforward. The implementation for the gyrator has been described by Hamill[3]. However the implementation of the current drive requires some discussion. The straightforward approach is to drive the circuit with a current source as shown in the top of Figure 5 where the value of the AC current is set as the complex value of the drive point velocity from the mechanical model.

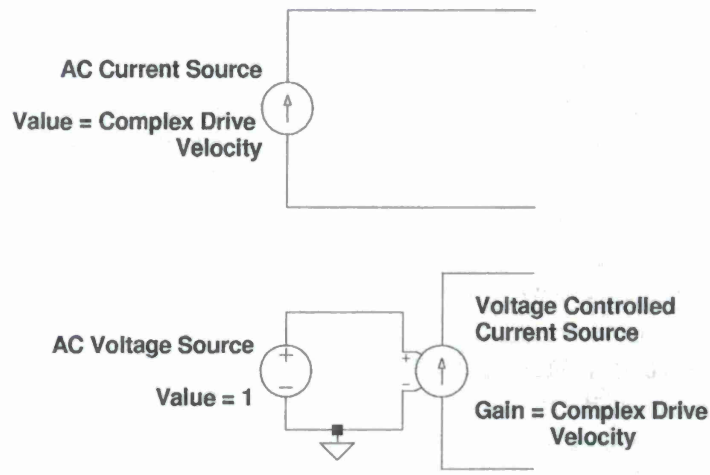

The two implementations have the same drive current.

Figure 5: Two equivalent implementations for the current source that drives the analog circuit. The lower version is preferred to work around an issue in COMSOL version 4.2a.

Doing this yields a correct model. However COMSOL 4.2a requires that the value of a current source be set using separate values for the magnitude and phase of the excitation signal. The calculation of magnitude and phase from the complex velocity value introduces a nonlinearity into the model that is otherwise a completely linear. The existence of this nonlinearity makes the solution slower and far less robust.

As an alternative, the circuit in the lower part of Figure 5 provides the same drive current using the complex velocity and not requiring the extraneous calculation of magnitude and phase values. In this case, the drive current is generated by a Voltage Controlled Current Generator, whose gain can be set to the complex value of the velocity. The control input of this generator is simply an AC voltage of unit magnitude. Note that the need for this “trick” is caused solely by the COMSOL design decision on the input format for the current generator, and is not inherent in the model. Future versions of COMSOL may change the input format to allow the option of complex input so that either version of Figure 5 would perform the same.

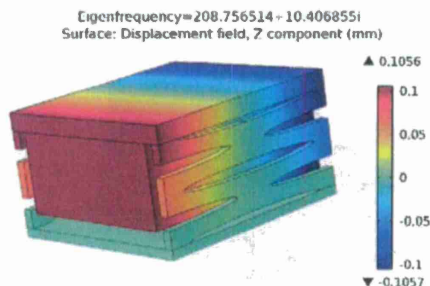

Figure 6: The rocking vibration mode is at 209 Hz before including the coupling force of the drive rod. This drive rod stiffness is expected to stiffen the assembly somewhat and increase the actual resonance frequency (see Figure 9)

The lowest three modes of vibration for the pure mechanical system are at 208 Hz, 266 Hz and 457 Hz. The first resonance is the end-to-end rocking mode, shown in Figure 6. This mode couples to the transducer analog unless the the drive rod is attached at the center point, which is a node. Two different attachments in this dimension will be shown below. The second mode is a purely translational motion of the transducer up and down on the springs, as shown in Figure 7. The third mode is a side-to-side rocking motion that does not couple to the analog model, because the drive rod is always at a node of that mode.

4 Available Output Power

The combined FEA-Analog model described above was run throughout the low frequency region that included the translational and rocking mode resonances of the transducer on its spring mounts. The electrical output power for a 1 g acceleration (9.8 m/s^2) input is shown in Figure 8. Note that the primary resonance has moved from the purely mechanical value of 266 Hz to approximately 305 Hz, due to the addition of the stiffness of armature of the transducer. At resonance, the model predicts approximately $250 \mu\text{W}$ of electrical output power for a 1 g acceleration input. The response is also reasonably broadband, having approximately 40 Hz at the half power points of

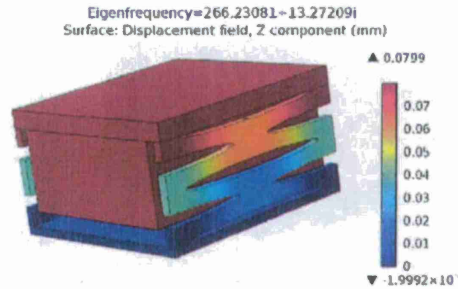

Figure 7: The primary translational vibration mode is at 266 Hz before including the coupling force of the drive rod. This drive rod stiffness is expected to stiffen the assembly somewhat and increase the actual resonance frequency (see Figure 8)

the curve. With this level of damping in the springs, a broadband vibration source of $1g/\sqrt{\text{Hz}}$ could produce 1 mW or more output power.

The peak displacement of this resonant vibration for single frequency input is approximately $24\mu\text{m}$ (approximately 0.001 in.). This is approaching the saturation limit of the device, and its shock protection features would likely limit the vibration at two or three times this amplitude. Thus for single frequency excitation, the amplitude limit would be reached before the power output reached 1 mW.

5 Alternative Design Features

The device as described and analyzed above has full reflection symmetry across the x and y planes through the center of the transducer. The drive rod from the transducer to the mounting plate is located exactly in the center. In this configuration, only one mode of vibration is excited by the acceleration of the base plate. In an alternative design, the drive rod might couple at a point that is not symmetrically located. Breaking the symmetry in this way would allow additional vibration modes to be excited, and possibly increase the generated output. This idea was tested by connecting the drive rod at the position 80% of the length dimension and centered in width. This introduces an asymmetry in one dimension, and allows one of the rocking modes to be excited by the vibration drive.

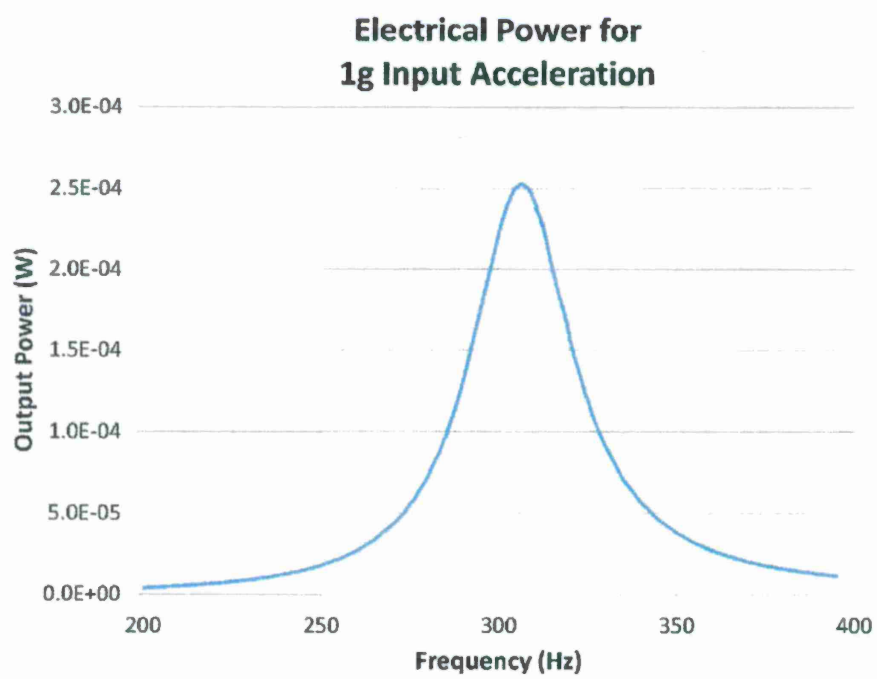

Figure 8: Electrical output power for a 1 g acceleration input at the mounting plate.

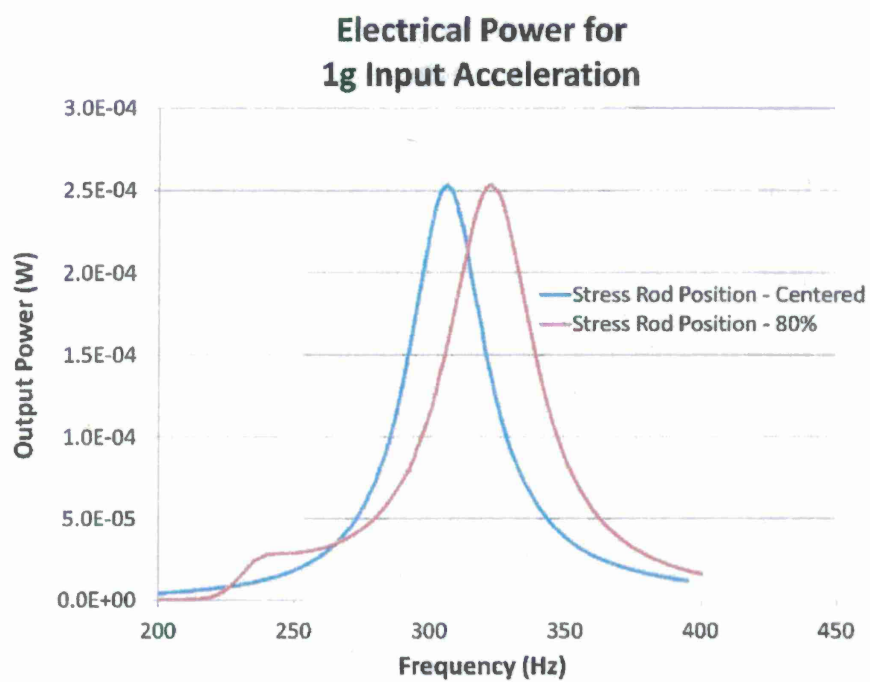

Figure 9: Electrical output power for 1 g acceleration input for the two cases of stress rod attachment. The asymmetrically located attachment allows a rocking mode to be excited and contribute a small amount to the output.

Figure 9 shows the power output for the asymmetrically coupled transducer compared to that for the symmetrically coupled device. The small resonant feature near 230 Hz is evidence of the rocking mode contributing to the output. The magnitude of the contribution is small, perhaps 10% the value at the primary resonance. However it may be possible to further improve this contribution by optimizing the design to enhance the contribution of this mode. For example, it might be possible to adjust the mass distribution in the top plate to move the two resonant frequencies closer together, which would increase the output of the rocking mode and increase the overall bandwidth of useful energy generation.

The work to date has only scratched the surface of all the design variables that can be varied to optimize the design. The analysis gives confidence that a solution can be found to obtain the order of 1 mW of electrical power from a broadband vibration source of $1 \text{ g}/\sqrt{\text{Hz}}$. Note also that the output power would increase if the source vibration had significant energy at higher frequencies and the mounting system resonance frequencies were increased accordingly. The example above has pushed the resonance to the lowest reasonable frequency because many ambient sources have energy in this frequency range. If a higher frequency source were available, a design with higher resonance frequency would be straightforward to implement.

6 Caveats

The calculations reported in this paper that lead to the information in Figure 8 are believed to be at least approximately correct, based on the testing performed by Vitt and reported in his thesis[2]. However, Vitt's calculated power output overestimated the measured output from his transducer samples by approximately 20%. That level of inaccuracy in the model is expected to carry over directly to the estimates here. In addition, the practical efforts to package and shock harden the design may reduce the available power by an amount that is difficult to estimate.

The issue of shock hardening the device will be a significant challenge as the design moves forward. The spring mounts must allow the motion to be as free as possible up to the design limit of the power output. For a wideband energy sensor subjected to its design limit of vibration, one would expect occasional amplitude peaks that go beyond the saturation limit of the transducer that would occasionally activate the limiting mechanism. However,

those high excursions might not be any more frequent or higher in amplitude than occur for a hearing aid transducer subjected to its maximum output signal level as it varies through the peaks of the speech waveform.

The more stringent test would be a drop test that would ensure survival and good performance after handling shocks and accidental drops by the user. The assembly of this concept study is not expected to withstand that kind of accidental abuse. A more robust design would need to be strengthened against vibration and shock in all three linear dimensions and against torques around all axes. The design would also need to incorporate hard limits on the motion of the transducer case to keep that large mass from exerting an unreasonable force in any direction on the armature.

7 Suggestions for Further Study

Perhaps the most important next step in this activity should be to finalize a prototype design with springs that can be obtained quickly and a device design that can be assembled and tested as easily as possible. It is likely that the springs can be fabricated using a prototyping "3D Printer" technology. Such a device would verify the calculations presented here and provide the ability to demonstrate the capability for a commercialization partner.

Beyond that, a study, which could be performed simultaneously with the above, should be performed to understand the relationship of material selection and spring damping on the peak response and bandwidth of the device presented here. Presumably the Q of the resonance curve should be low enough that the amplitude of motion stays just below the saturation limit of the device. Higher damping might provide a greater bandwidth, but not have greater output as the mechanical losses become too great.

Mentioned briefly above is the possibility of designing the device so that its multiple mechanical resonances play a greater role in the power generation. It should be straightforward to redesign the device so that its lowest rocking mode can be activated by the motion. That simply involves an asymmetric mounting of the transducer so that the drive rod is no longer near a node of the vibration mode. Perhaps more difficult would be finding ways for the rocking modes to participate more actively in power generation than they do in the present design. A redistribution of the mass in the top plate and possible redesign of the springs might move in the right direction.

Finally it should be possible to empirically improve the analog model

of the transducer to include both the translational and rotational vibration sensitivities. By itself, that is a major undertaking in measurement and analog model development, but the return might be great if the rotational mode does play a significant role in the vibration sensitivity.

References

- [1] Joe Jensen and Finn T. Agerkvist, "Nonlinear time domain modeling of balanced-armature transducers," *J. Audio Eng. Soc.* **59**(3) 91-101, March 2011.
- [2] Nikolas T. Vitt, "Investigation of a Balanced-Armature Transducer for Vibrational Energy Harvesting," M.S. thesis, The Pennsylvania State University, State College, PA, 2011.
- [3] David C. Hamill, "Lumped equivalent circuits of magnetic components: the gyrator-capacitor approach," *IEEE Trans. Pow. Elec.* **8**(2) 97-103, April 1993.

Distribution List

Distribution List for the ARL Penn State Technical Report 012-003 entitled "Vibration Energy Harvesting Concept using a Balanced Armature Transducer" by Stephen C. Thompson dated April 16, 2012.

Office of Naval Research
875 North Randolph Street
Arlington, VA 22203-1995
Attn: Jan Lindberg, ONR 321

Defense Technical Information Center
8725 John J. Kingman Road
Suite 0944
Fort Belvoir, VA 22060-6218

Applied Research Laboratory
The Pennsylvania State University
P.O. Box 30
State College, PA 16804-0030
Attn: S. C. Thompson

Knowles Electronics
1151 Maplewood Drive
Itasca, IL 60443
Attn: Ray Kirchhoefer

IntriCon Tibbetts
16 Bayberry Lane
Camden, ME 04843
Attn: Peter Madaffari

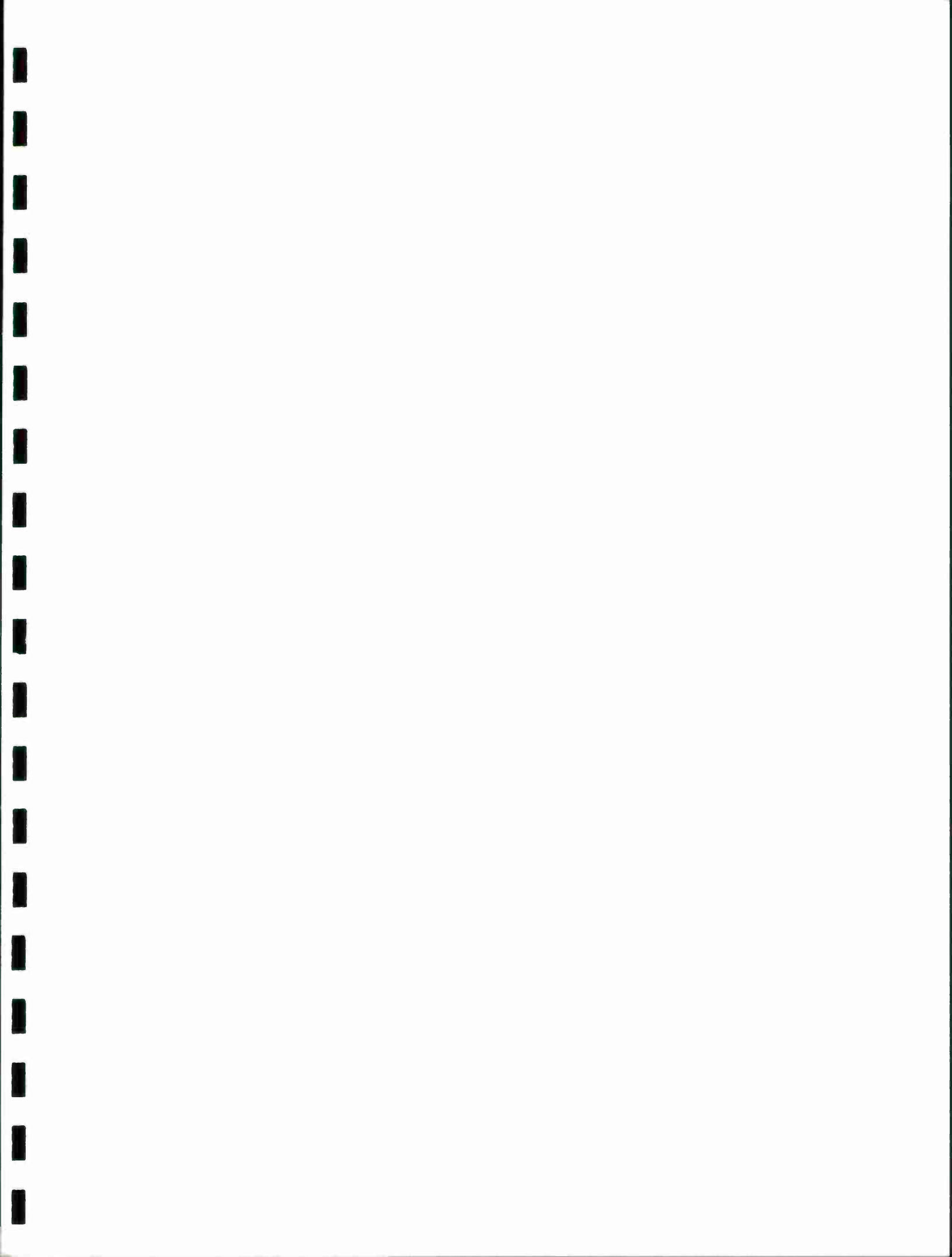

The Pennsylvania State University
Applied Research Laboratory
P.O. Box 30
State College, PA 16804