

NDIA E2S2 Symposium

New Orleans, LA.

(May 9-12, 2011)

A Sustainability Approach to Upgrading Corroded, Inoperable or Difficult to Open Fire Hydrants via an Off-the-Shelf Stainless Steel Retrofit Kit

Eddy Dean Smith, Ph.D., DEE

Mark Ginsberg

Vicki VanBlaricum

Vince Hock

Mike McInerney

Engineer Research and Development Center/
Construction Engineering Research Lab
Champaign, IL.



®

US Army Corps of Engineers
BUILDING STRONG®



Report Documentation Page

Form Approved
OMB No. 0704-0188

Public reporting burden for the collection of information is estimated to average 1 hour per response, including the time for reviewing instructions, searching existing data sources, gathering and maintaining the data needed, and completing and reviewing the collection of information. Send comments regarding this burden estimate or any other aspect of this collection of information, including suggestions for reducing this burden, to Washington Headquarters Services, Directorate for Information Operations and Reports, 1215 Jefferson Davis Highway, Suite 1204, Arlington VA 22202-4302. Respondents should be aware that notwithstanding any other provision of law, no person shall be subject to a penalty for failing to comply with a collection of information if it does not display a currently valid OMB control number.

1. REPORT DATE MAY 2011		2. REPORT TYPE		3. DATES COVERED 00-00-2011 to 00-00-2011	
4. TITLE AND SUBTITLE A Sustainability Approach to Upgrading Corroded, Inoperable or Difficult to Open Fire Hydrants via an Off-the-Shelf Stainless Steel Retrofit Kit				5a. CONTRACT NUMBER	
				5b. GRANT NUMBER	
				5c. PROGRAM ELEMENT NUMBER	
6. AUTHOR(S)				5d. PROJECT NUMBER	
				5e. TASK NUMBER	
				5f. WORK UNIT NUMBER	
7. PERFORMING ORGANIZATION NAME(S) AND ADDRESS(ES) Army Engineer Research and Development Center, Construction Engineering Research Laboratory, PO Box 9005, Champaign, IL, 61826-9005				8. PERFORMING ORGANIZATION REPORT NUMBER	
9. SPONSORING/MONITORING AGENCY NAME(S) AND ADDRESS(ES)				10. SPONSOR/MONITOR'S ACRONYM(S)	
				11. SPONSOR/MONITOR'S REPORT NUMBER(S)	
12. DISTRIBUTION/AVAILABILITY STATEMENT Approved for public release; distribution unlimited					
13. SUPPLEMENTARY NOTES Presented at the NDIA Environment, Energy Security & Sustainability (E2S2) Symposium & Exhibition held 9-12 May 2011 in New Orleans, LA.					
14. ABSTRACT					
15. SUBJECT TERMS					
16. SECURITY CLASSIFICATION OF:			17. LIMITATION OF ABSTRACT Same as Report (SAR)	18. NUMBER OF PAGES 40	19a. NAME OF RESPONSIBLE PERSON
a. REPORT unclassified	b. ABSTRACT unclassified	c. THIS PAGE unclassified			

Our Customers, Soldiers, Families, and Civilians

Home to
the
Force



Power
Projection

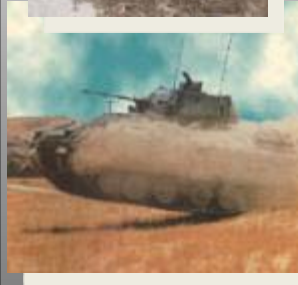

Work &
Training

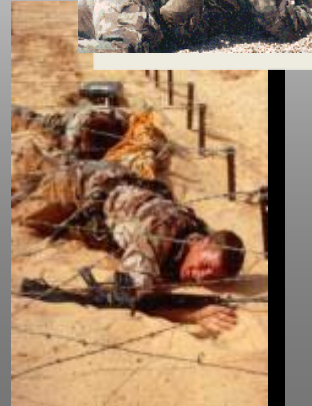

... are Army Customers!

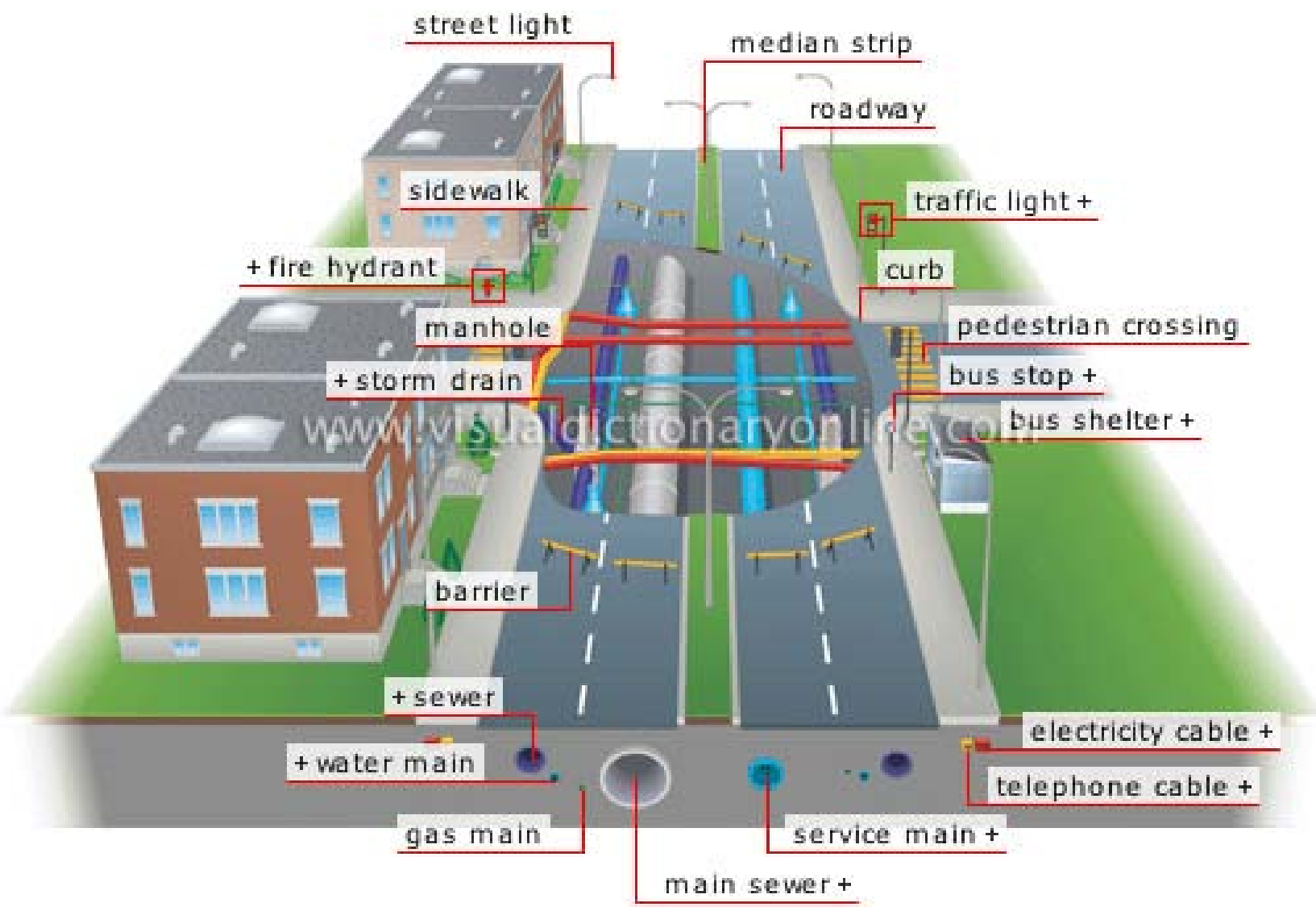

Some of Our Corrosion R&D is Related Is Dedicated to Water Related Infrastructure/Networks

ASCE 2010 Report Card for America's Infrastructure

- Drinking Water : D-



Tuberculation in 6-inch Unlined Water Main



36 Inch Main Break

*Extent And Magnitude Of The **Corrosion** Problem*

- Potable **Water** Distribution System: 880,000 miles of pipe comprise the nation's drinking water distribution network [AWWA WATER\STATS2002].
 - 880,000 miles of larger water distribution pipe in U.S.
 - 7 million fire hydrants
 - 50,000 large water storage tanks
 - Almost 1 million miles of sewers

Fire Hydrants are an Integral Component of Water Distribution Networks and If They Are Corroded, They May **Not Work When Needed or They May Be Difficult to Open.**

- **Objective of Our Corrosion Program:**
- **Upgrade Existing Corroded Fire Hydrants with a “No-Dig” Corrosion Resistant Technology.**



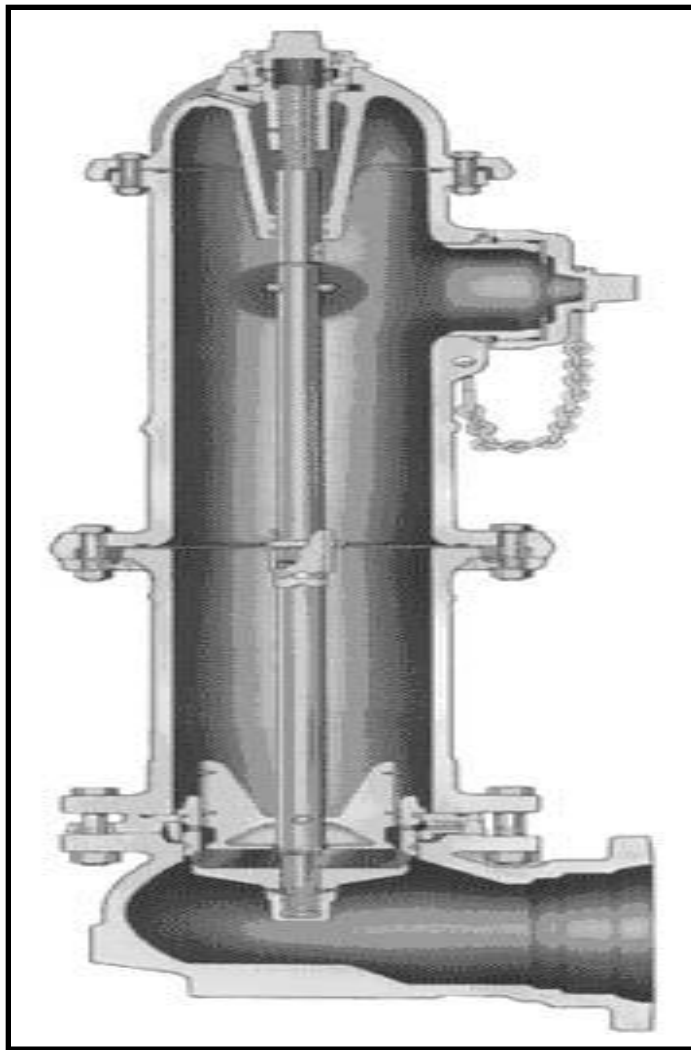

Standard Dry Barrel Fire Hydrants Have Cold-Rolled Steel Stems Which Can Corrode





Michael C. Green, Executive Vice President of Water Infrastructure Consultants, located at 214 Florida Avenue, New Smyrna Beach, Florida 32169

- ...During our investigations on the hydrant security aspect, we have seen a surprisingly high frequency of **corrosion** issues on several internal hydrant components. Hydrant components that are made of cold-rolled steel are highly susceptible to **corrosion**. Such corrosion, besides the water quality/contamination concern, can negatively affect hydrant operability....

Nick Selembo (fire hydrant repair expert):

“ From the moment a fire hydrant is installed, it begins to rust. In time, the caps may rust so tight they can not be removed. Valve and joints develop blistering and pitting to the point of becoming unusable This is often referred to as being ‘galded’. Hydrants in this condition can be very difficult to open, or even contain parts so corroded as to make using them under pressure a dangerous enterprise”

We Chose to Demonstrate a Proprietary Davidson Valve Which Was Being Marketed as an Anti-Terrorism Device to Protect Fire Hydrants from Deliberate or Accidental Contamination.

Our Objective was to take advantage of the fact that the stem was manufactured from 304 series stainless steel.

The Demonstration was funded by the Corrosion Program, but realized the added benefit of demonstrating the internal check valve as a protection against contamination

Components of the Proprietary Corrosion-resistant and Anti-Terrorism Valve



- Meets AWWA C502 Specs
- Offers continuous protection
- Easily retrofitted into new or existing hydrants
- Stealth design
- Fire Fighters operate hydrant as usual
- Ten year warranty
- Extremely durable materials for long life
- Qualifies for funding from several sources

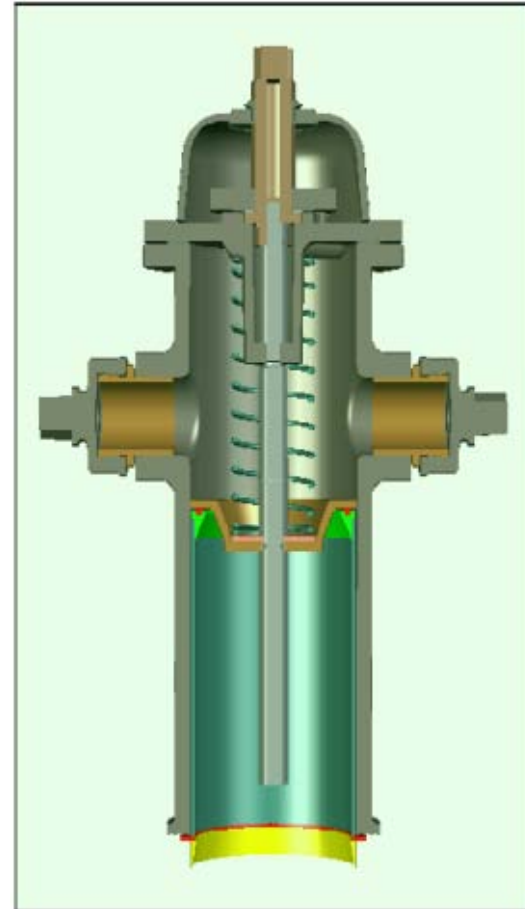





The Retrofit System being Demonstrated Meets the Following Criteria:

- American Water works Association's Standard C502 for dry barrel hydrants.
- AWWA subparagraphs for backflow prevention.
- No expensive evacuation is required.
- The device does not show loss of water flow for fire fighting and no negative effect on hydrant function, including weeping.

Hydrant Upgrade Plan

- All the hydrants on the installation were surveyed.
- 90 were selected to have their inner workings replaced with the upgrade kit.
- In order to access the widest possible corrosion conditions on diverse manufacturer's hydrants, 6 different makes/models were selected for upgrade.
- The upgrade stems of 84 /90 were 304 series stainless steel. 6 were 316 stainless steel.

- Each retrofitted hydrant was catalogued, cross referenced by GPS, street location, serial number of both old hydrant and upgrade kit.
- A record and photograph recording of the condition of each set of parts being replaced was documented.
- A video and HD digital camera record documented the steps necessary to retrofit the older units.
- The torque necessary to operate the hydrant was measured by a torque wrench before and after upgrade.

Torque Required To Open A Hydrant Before Servicing

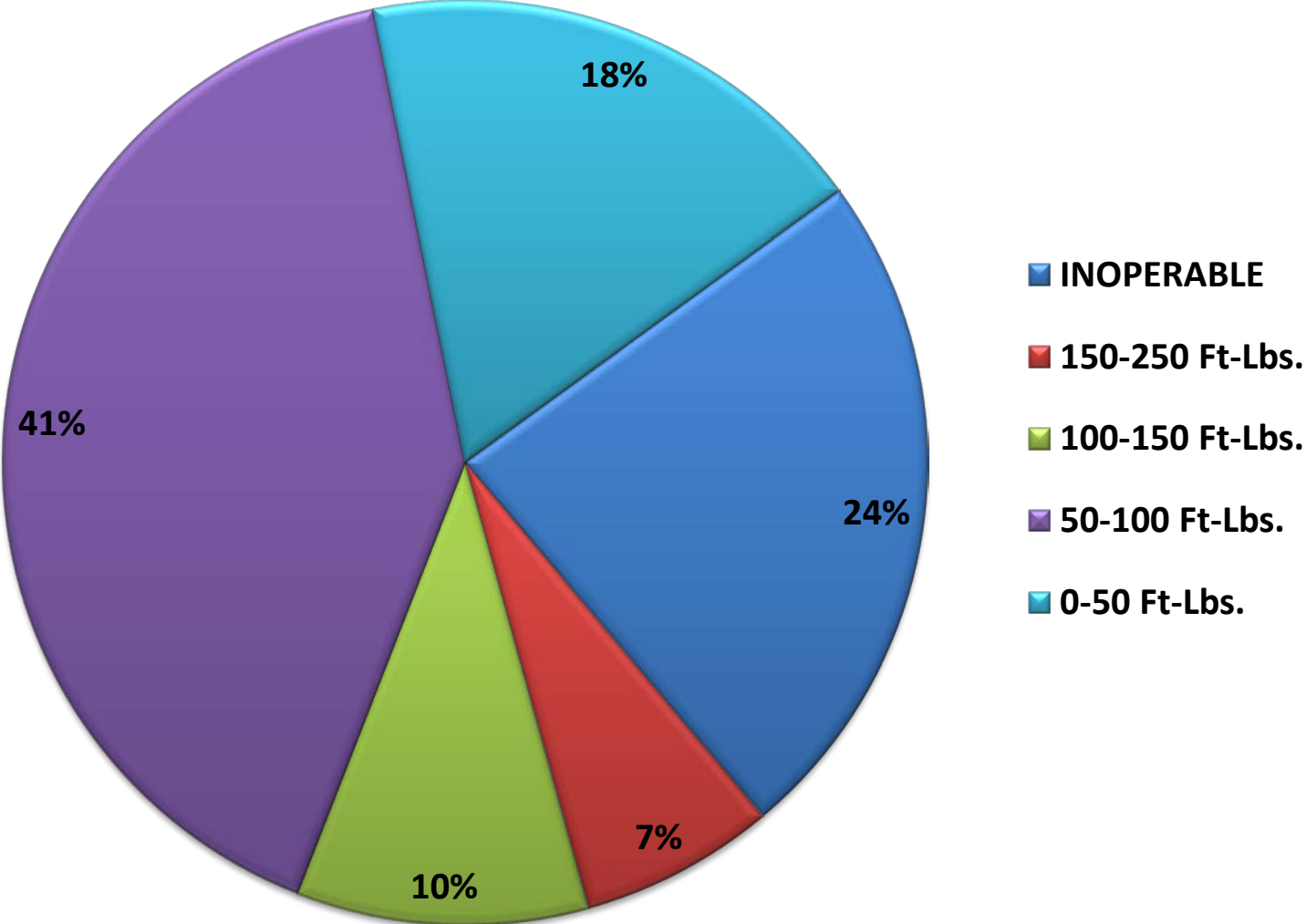

Torque Required To Open A Hydrant After Servicing

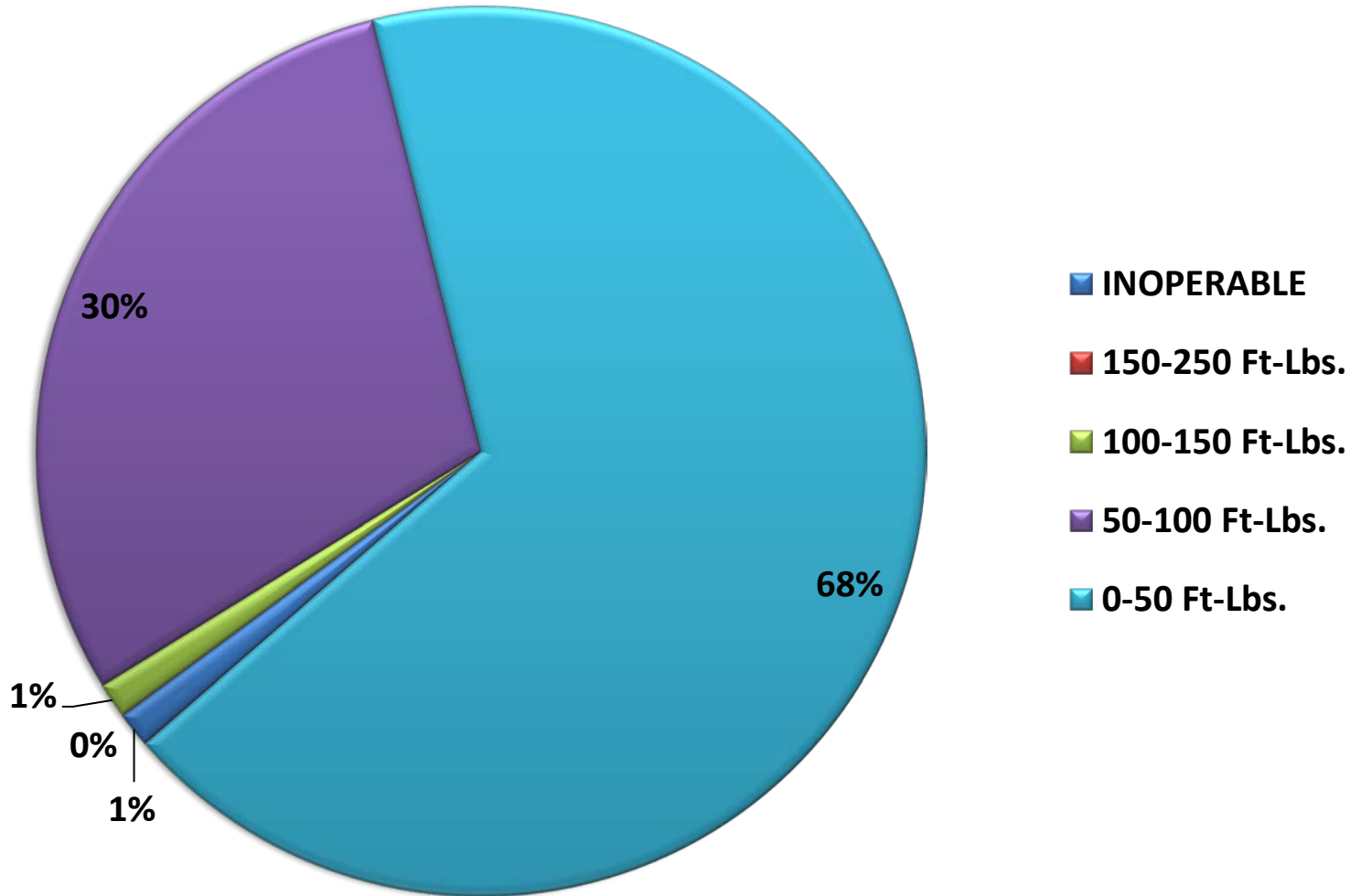

Fire Hydrant Standard Full Flow Testing:

- Full flow tests were made on all 90 hydrants and the experimental controls using a flow meter and experienced technician both immediately before and immediately after installation of the new inner workings. Static pressure was measured.
- The objective of this battery of testing is to compare performance of the new retrofit system to the old system.

Flow Rate Of A Hydrant Before Servicing

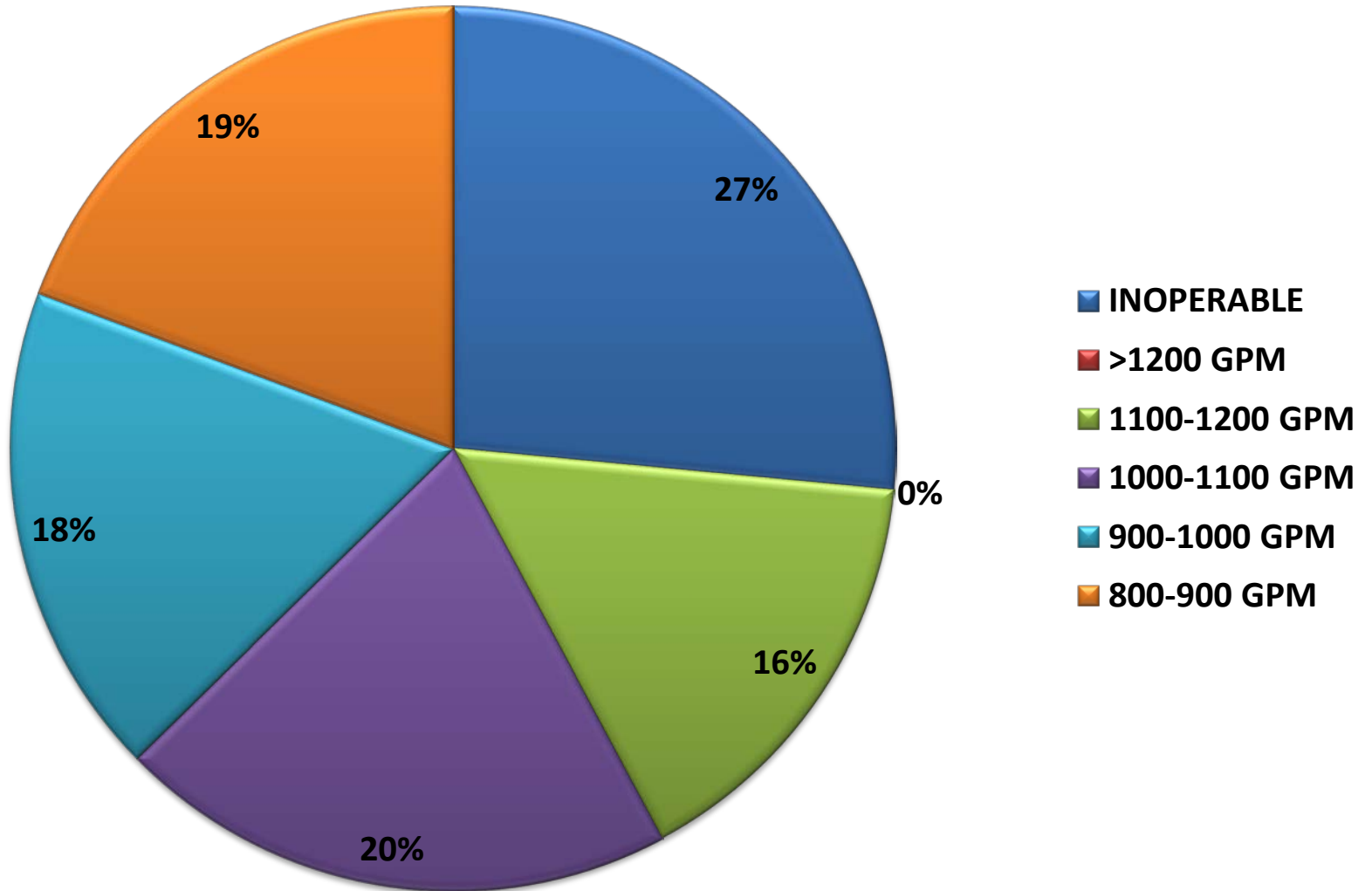

Flow Rate Of A Hydrant After Servicing

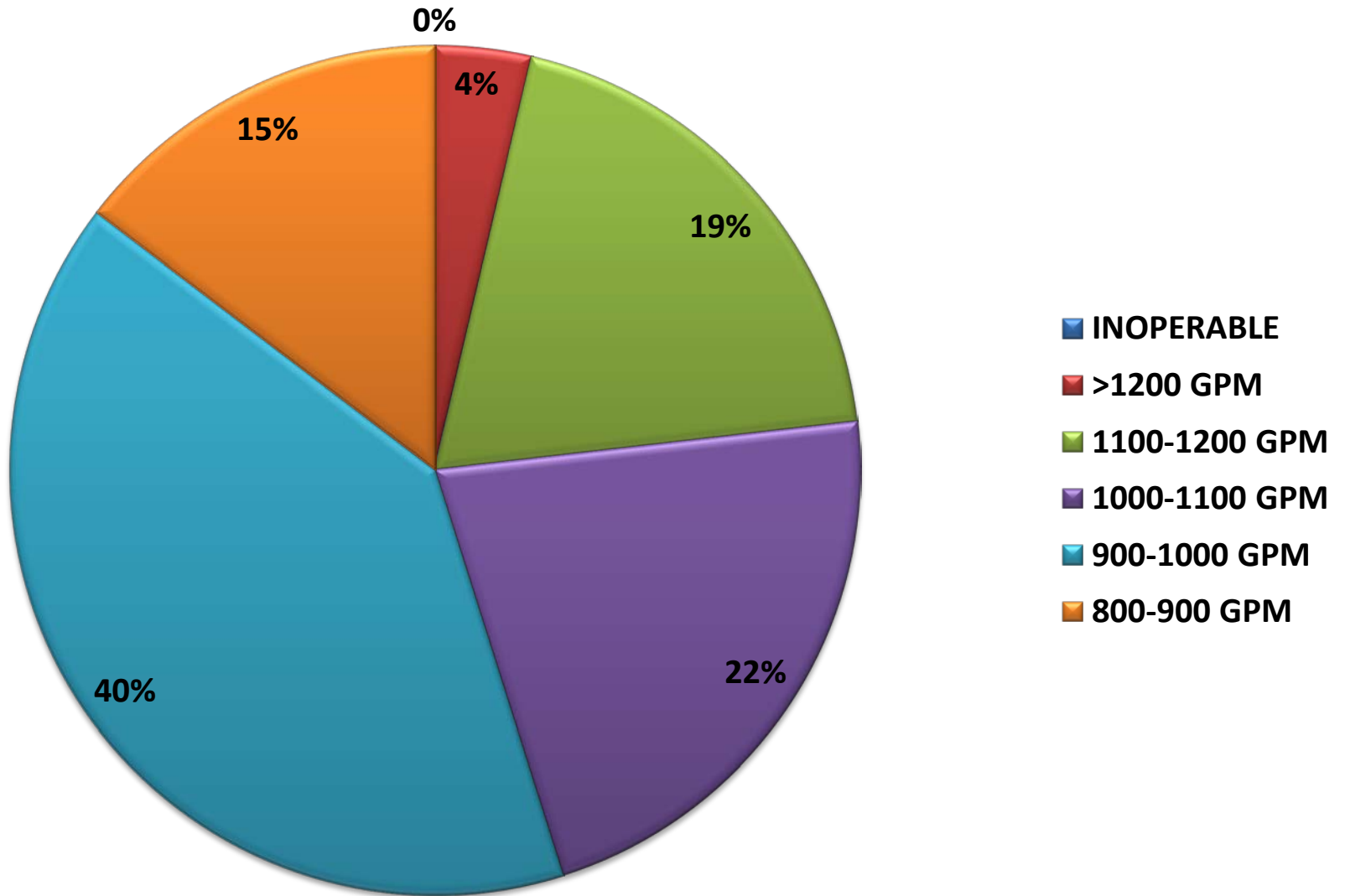

Return on Investment (ROI) Calculations:

- The retrofit system will be evaluated for performance and ROI and consideration for wider application within the Army and Department of Defense in either high priority locations or for use on an installation-wide basis.

Demonstration is designed to influence Doctrine/Specs related to Technology Transfer of a New Generation of Fire Hydrants

- United Facilities Guide Specs.- Water Distribution
- United Fire Code- Fire Protection for Facilities
- ACSIM Installation Design Standard
- AWWA C-502 for hydrant flow and head loss
- Whole Building Design, ASTM, National Fire Protection Association and Underwriter's laboratories.
- Others

The Age of Terrorism Threats:

- Denial of service



and collateral damage

Force Protection by Upgrading Fire hydrants: The Threat is that Army Water Systems are Vital and Vulnerable.

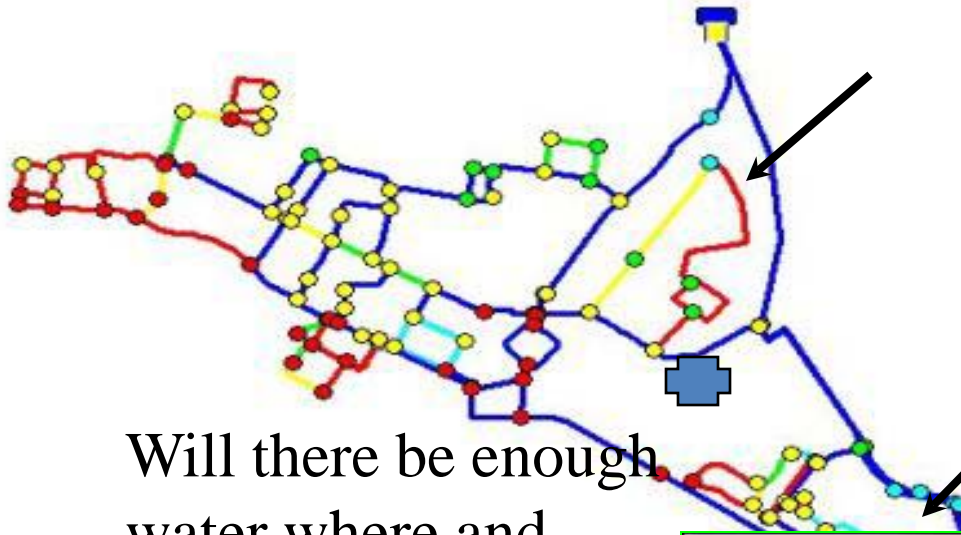

Will there be enough water where and when it is needed?

Is it safe?

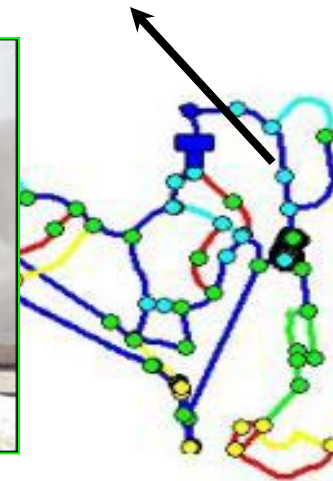

Integrated Water Security - PHYSICAL PROTECTION MEASURES:

- According to report by the General Accounting Office released in 2004:

The *distribution system* is the top vulnerability of drinking water systems with hydrants specifically referenced

“...the distribution of a chemical, biological or radiological agent via the distribution system could be difficult to detect until it is *too late* to reverse any harm done.”



The Threat:

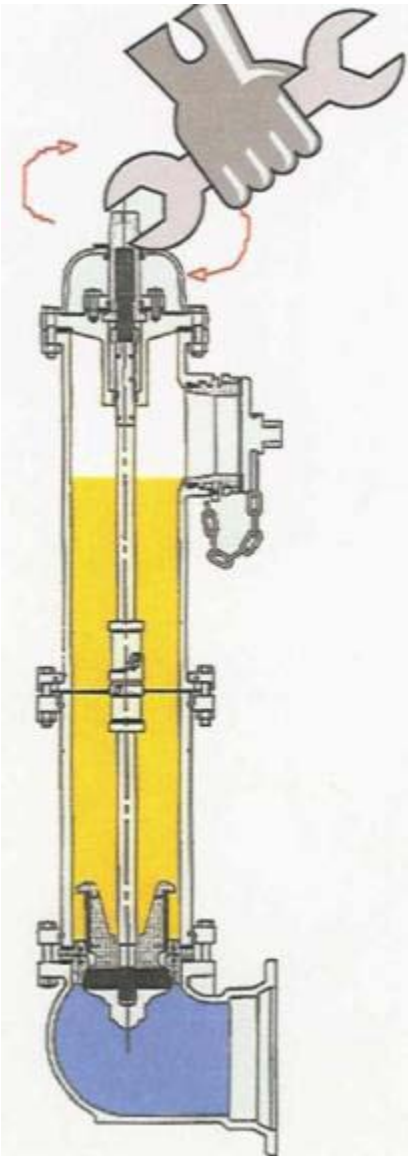

- Injecting agents into drinking water via a fire hydrant is one means of delivery.
 - Filling hydrant with agent and siphoning into main
 - Pumping into hydrant using truck or other tank container as pump

Escherichia Coli

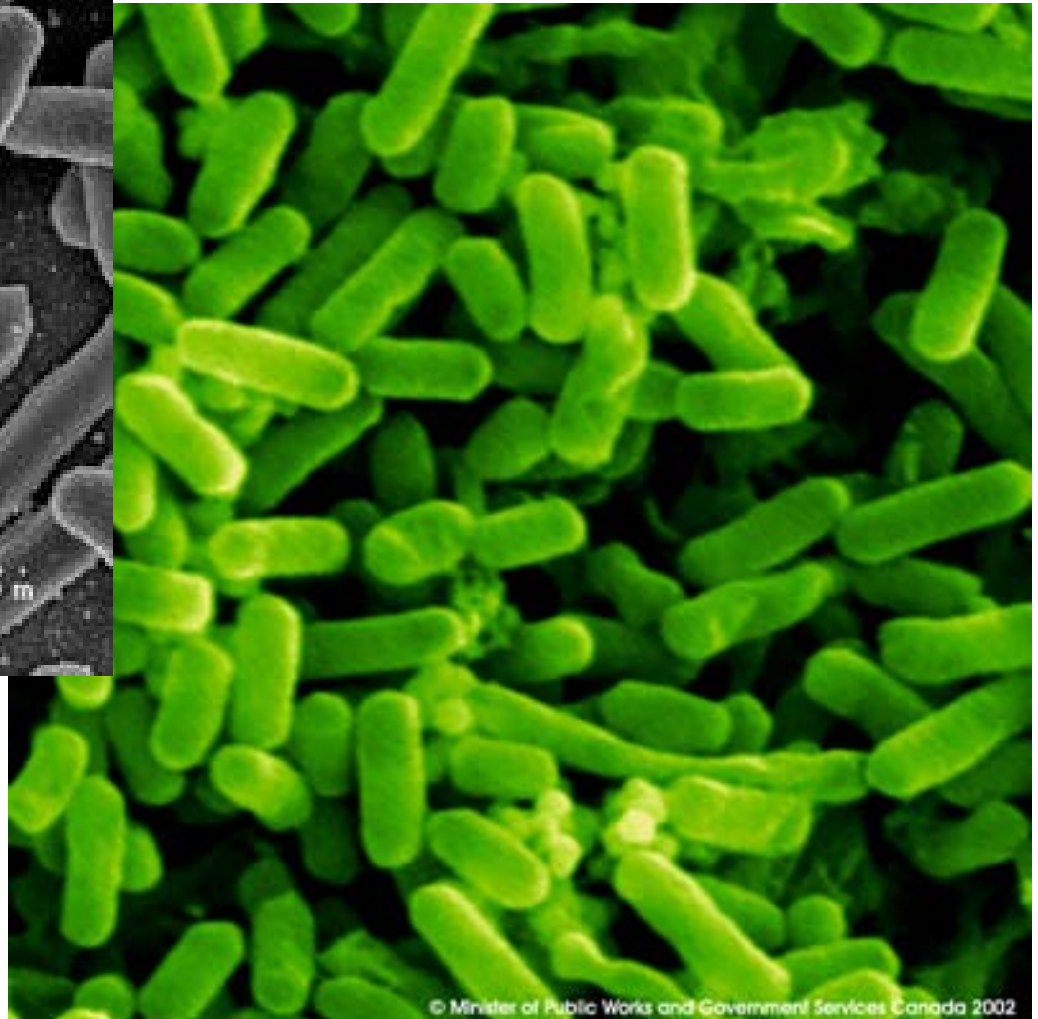
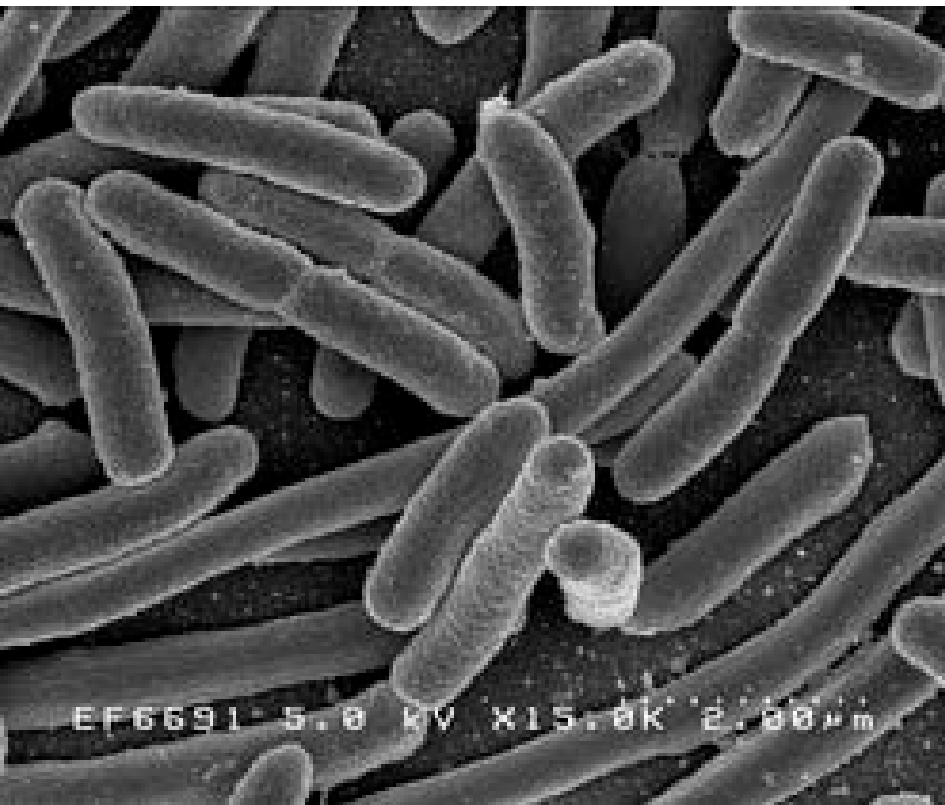

Number of 55 Gallon Barrels of Material Required to Poison 1 Million Gallons of Water for Some of the Most Dangerous Compounds

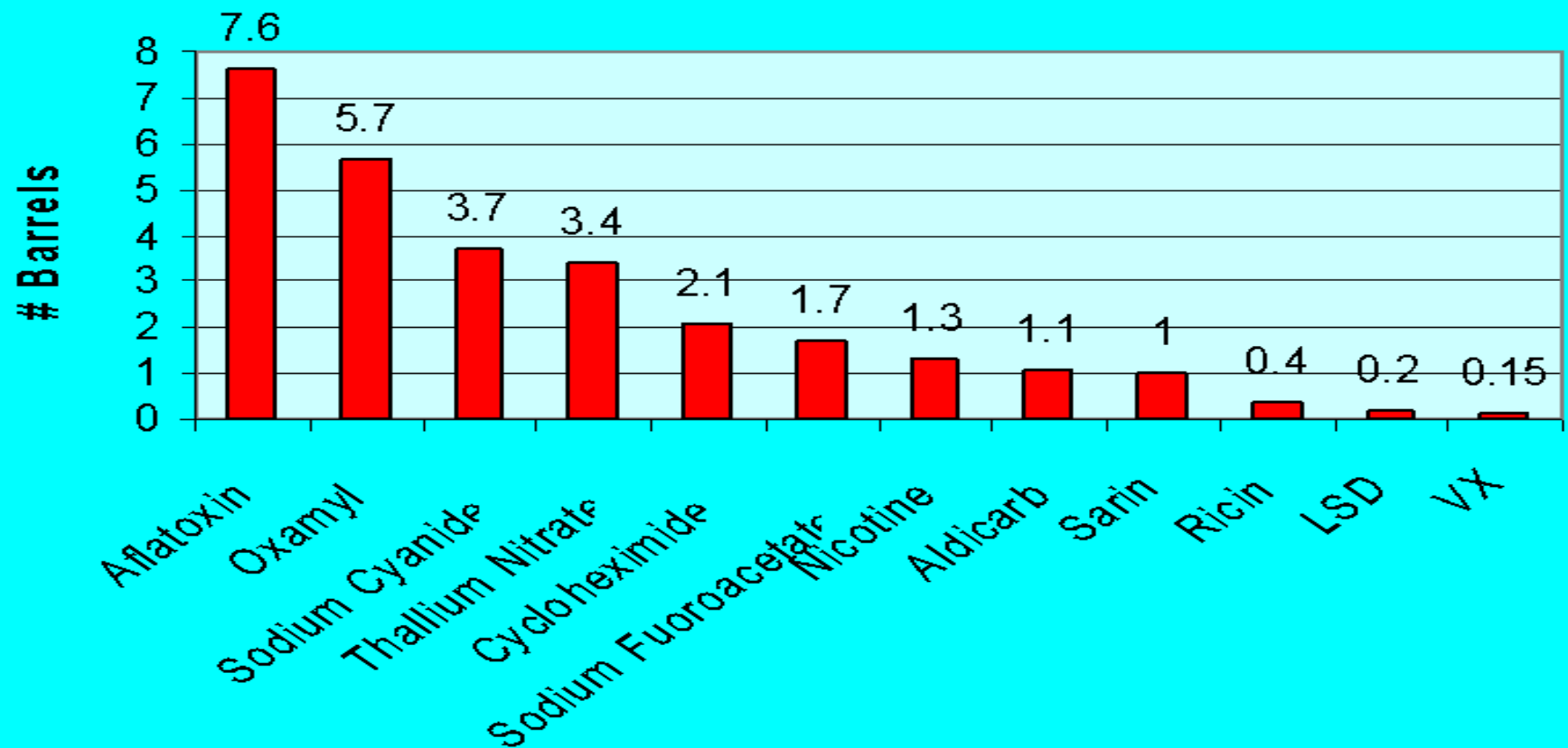

Attack History

- September 2003 -- FBI bulletin warns of al Qaeda plans found in Afghanistan to **poison U.S. food and water supplies**.
- December 2002 -- Al Qaeda operatives arrested with plans to attack **water networks** surrounding the Eiffel Tower neighborhoods, Paris.
- April 2003 -- Jordan foils Iraqi plot to poison **drinking water supplies** from Zarqa feeding **U.S. military bases** along the Eastern desert.
- February 2002 – Al Qaeda arrested with plans to attack **U.S. embassy water** in Rome with “**cyanide**”.
- May 1983 – Israel uncovers Israeli Arab plot to poison **Galilee water** with “an unidentified powder”.
- 1968 – Yippies threaten the Democratic National Convention in Chicago with plans to dump **LSD into water supplies**.

A Cautionary Tale:

- 1980 Purposeful injection of chlordane into distribution system at an isolated valve location
- System served 10,500, of which 154 reported ill effects
- Continued contamination evident following initial purging resulted in mandated use restrictions
- Ultimately resolved by extended flushing (concentrations reduced from ~1000ug/l to 0.3ug/l target over 3 months)
- Flushing able to restore usage in 1 month, but 9 months required for potable clearance
- Water heaters particularly difficult to clean

Integrated Water Security System Summary

•Threat

- U.S. municipality disabled for 9 months by deliberate attack
- Verified by DHS/EPA as a threat to life and mission
- Attack is easy and cheap to launch

•Prevention

- Prevent accidental and deliberate contamination
- Layered “Defense in Depth” deters an attack at each step
 - Informed public
 - Hardened access points
 - Ex. Hydrant - Lock, Anti Terrorism Valve, Alarm system

Real-Time Detection

- Advanced Physicochemical Based Decision Support
- Guardian Blue Contaminant Monitoring Systems Connected by SCADA
 - Based on standard water quality parameters assuring that the system is maintained

Real-Time Response

- Critical Facilities Protected by Standby Distributed Water Treatment
- Real-time controlled SCADA valves limit spread of contamination

Rehabilitation

- Extent and expense of cleanup reduced due to limit spread of contamination
- Life safety and mission continuity enhanced by minimizing down-time.

Smart tamper-resistant hydrants

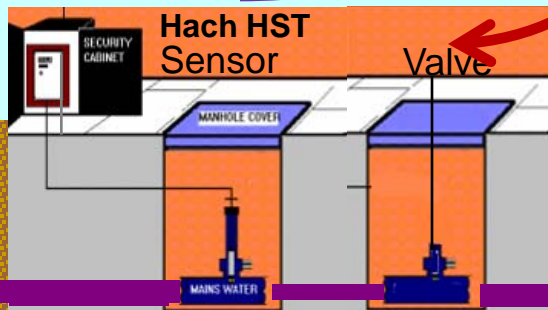
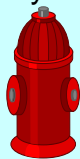

SCADA



Operator Workstation



ERDC Designed Control System
Command Center



Integrated Water Security Protection Mechanisms:

1. Vulnerability Assessment and Physical Security Using Locks, Fences, Motion Sensors, Cameras, Tamper Resistant Fire Hydrants.
2. Detection of Deliberate/Accidental Chemical/ Biological Contamination.
3. SCADA Assisted Emergency Response .
4. Options to Provide Safe Water Supply to Military Command Centers, Hospitals, etc. with **“just-in-time” treatment systems.**
5. Pipe decontamination.

Summary

- **Water** security is a life-safety issue. **Water** supply systems on military installations are vulnerable to conventional, chemical/biological, and non-traditional agent contamination by terrorists.
- Army and DOD facilities' managers have identified **water** distribution systems as a critical part of the infrastructure needed to support fire suppression, troop deployment, and soldier welfare.
- **Fire hydrants** are a critical component of water network infrastructure and need protection from corrosion and security related problems and may need to be upgraded for security reasons.
- USACERL is currently performing a large scale demonstration on an Army facility upgrading existing corrosion prone fire hydrants that also serve the "Dual" purpose of preventing accidental/deliberate contamination of Army water supplies **via fire hydrants**

QUESTIONS/COMMENTS??

