

## Twenty years is too long – practical engineering approaches to materials substitution



Keith Legg  
ASETSDefense Lead  
Rowan Technology Group  
Libertyville, IL

# Report Documentation Page

Form Approved  
OMB No. 0704-0188

Public reporting burden for the collection of information is estimated to average 1 hour per response, including the time for reviewing instructions, searching existing data sources, gathering and maintaining the data needed, and completing and reviewing the collection of information. Send comments regarding this burden estimate or any other aspect of this collection of information, including suggestions for reducing this burden, to Washington Headquarters Services, Directorate for Information Operations and Reports, 1215 Jefferson Davis Highway, Suite 1204, Arlington VA 22202-4302. Respondents should be aware that notwithstanding any other provision of law, no person shall be subject to a penalty for failing to comply with a collection of information if it does not display a currently valid OMB control number.

1. REPORT DATE <b>MAY 2011</b>		2. REPORT TYPE		3. DATES COVERED <b>00-00-2011 to 00-00-2011</b>	
4. TITLE AND SUBTITLE <b>Twenty years is too long ?practical engineering approaches to materials substitution</b>				5a. CONTRACT NUMBER	
				5b. GRANT NUMBER	
				5c. PROGRAM ELEMENT NUMBER	
6. AUTHOR(S)				5d. PROJECT NUMBER	
				5e. TASK NUMBER	
				5f. WORK UNIT NUMBER	
7. PERFORMING ORGANIZATION NAME(S) AND ADDRESS(ES) <b>Advanced Surface Engineering Technologies for a Sustainable Defense ,Rowan Technology Group,Libertyville,IL,60048</b>				8. PERFORMING ORGANIZATION REPORT NUMBER	
9. SPONSORING/MONITORING AGENCY NAME(S) AND ADDRESS(ES)				10. SPONSOR/MONITOR'S ACRONYM(S)	
				11. SPONSOR/MONITOR'S REPORT NUMBER(S)	
12. DISTRIBUTION/AVAILABILITY STATEMENT <b>Approved for public release; distribution unlimited</b>					
13. SUPPLEMENTARY NOTES <b>Presented at the NDIA Environment, Energy Security &amp; Sustainability (E2S2) Symposium &amp; Exhibition held 9-12 May 2011 in New Orleans, LA.</b>					
14. ABSTRACT					
15. SUBJECT TERMS					
16. SECURITY CLASSIFICATION OF:			17. LIMITATION OF ABSTRACT <b>Same as Report (SAR)</b>	18. NUMBER OF PAGES <b>27</b>	19a. NAME OF RESPONSIBLE PERSON
a. REPORT <b>unclassified</b>	b. ABSTRACT <b>unclassified</b>	c. THIS PAGE <b>unclassified</b>			



# THE PROBLEM

- Many of the materials and coatings we currently use must be replaced for regulatory or performance issues
  - Cd plate, chromate processes and materials
- We used to be able to plan since the needs were obvious (even though the changes were glacial)
  - Although obvious changes rarely made until there is no choice
- It historically takes 20 yrs to go from lab to market
  - Often materials used commercially for years before qual even begins for aerospace and defense
  - Regulations commonly give only 5 years
  - Strategic materials shortages can occur even more quickly
- How can we do this much faster, with low risk, and better performance?

# Why does it take so long?

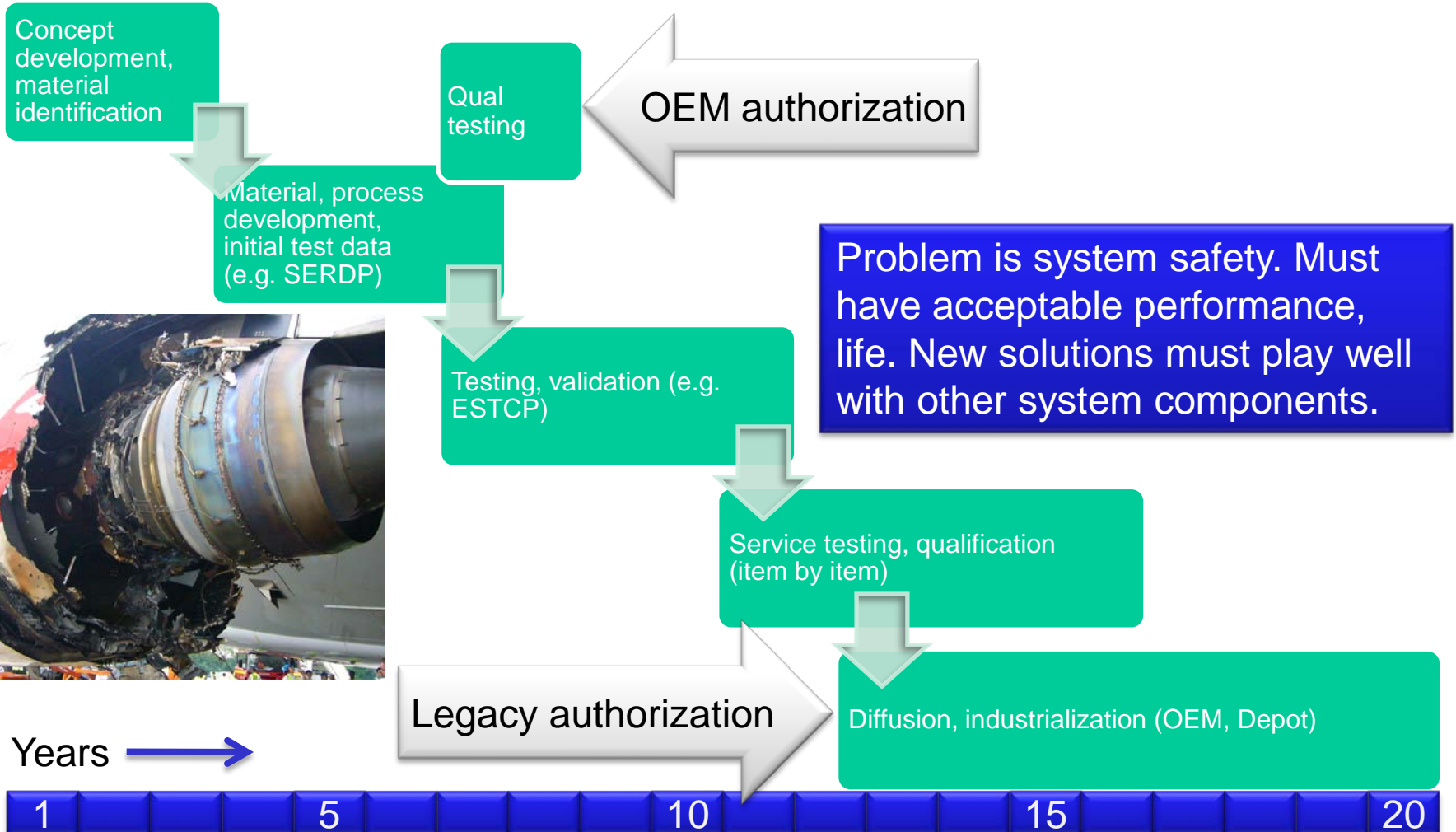

# Tools for better and faster adoption

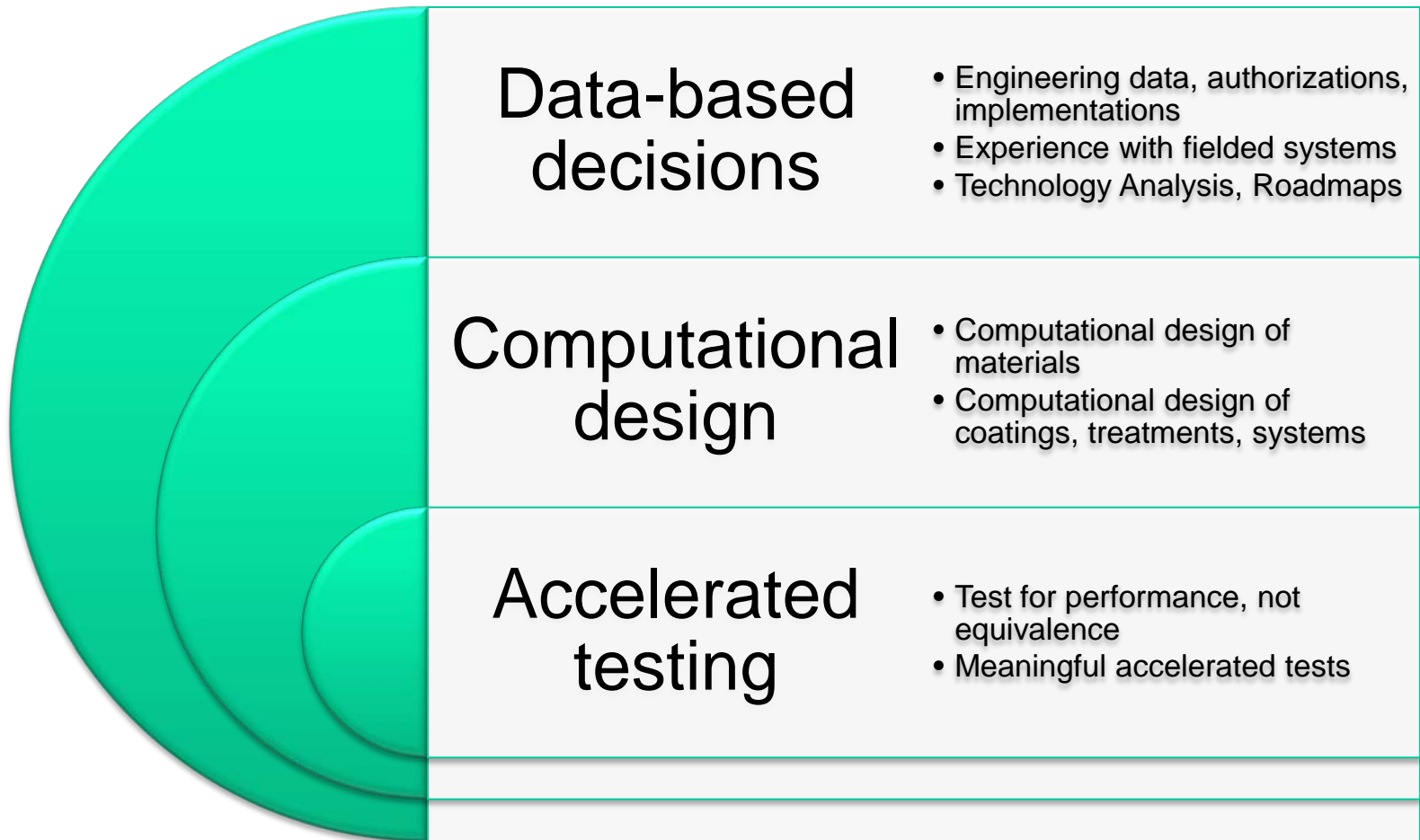



# DATA-BASED DECISIONS

- A good answer is often already available
- Many aerospace and defense requirements are unique, but does not mean commercial products cannot be adopted or adapted
  - Car fasteners have used metal-filled dip spin polymer coatings for years, adopted for military vehicles
  - Powder coat and e-coat long used on lawn furniture, adopted for military vehicles works better than paint
  - ZnNi electroplates adapted from commercial vehicle and earlier aircraft coatings to replace Cd on military systems



Data-based decisions

- Available data often not used
  - ❑ USMC CPAC developing database to track corrosion problems and solutions in fielded vehicles
  - ❑ Feed data back into design

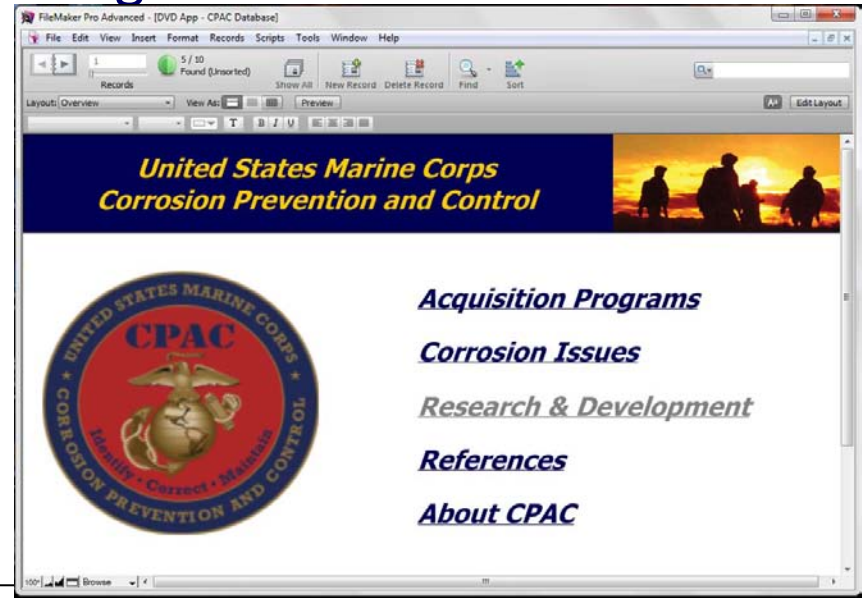

- ASETSDefense Surface Engineering Database is constantly updated to try to capture
  - ❑ High quality engineering data
  - ❑ Authorized technologies, materials
  - ❑ Implementations of clean technologies
- Scope
  - ❑ Not limited to DoD - military and commercial
  - ❑ Includes materials and applications from across the world

# ASETSDefense Database – Document types

Data-based decisions

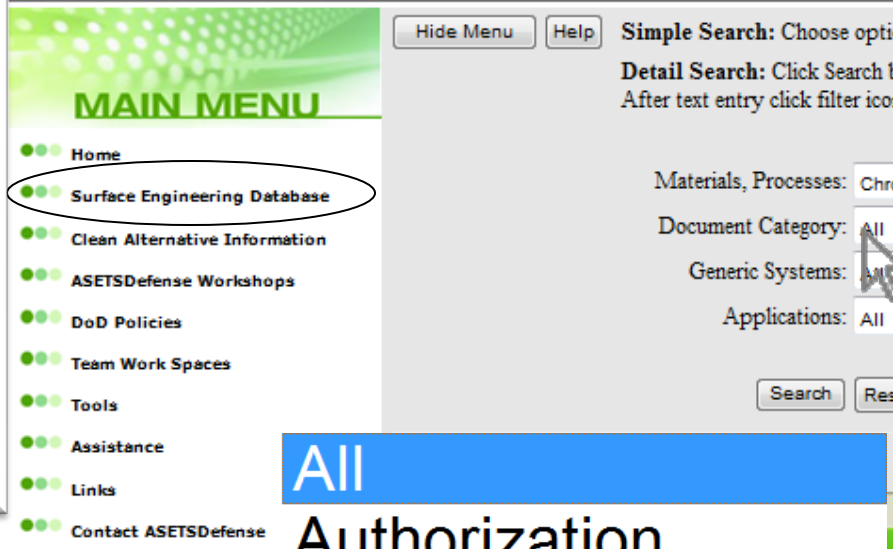

**MAIN MENU**

- Home
- Surface Engineering Database
- Clean Alternative Information
- ASETSDefense Workshops
- DoD Policies
- Team Work Spaces
- Tools
- Assistance
- Links
- Contact ASETSDefense

Hide Menu Help

Simple Search: Choose opti  
Detail Search: Click Search t  
After text entry click filter ico

Materials, Processes: Chr  
Document Category: All  
Generic Systems: All  
Applications: All

Search Res

- All
- Authorization
  - Implementation
  - Other
  - Project
  - Specification
  - Technical Report
  - Test Plan

- All
- Cadmium plate
  - Chromic acid anodize
  - Chromate adhesive bond primer
  - Chromate conversion
  - Chromate metallic-ceramics
  - Chromate primers
  - Chromate sealants
  - Hard chrome plate
  - High VOC materials
  - Coating removal (stripping)
  - Cleaners
  - Corrosion Preventive Compounds
  - Lead-free materials (e.g. DFLs)

# Roadmapping – e.g. Aerospace and Defense Roadmap, NASF

## Meeting ESOH regulatory requirements

Goals:	Routes:
Cr <sup>6+</sup> elimination from materials	Trivalent and non-chrome conversion coatings, sealers, paint systems, etc.
Cr <sup>6+</sup> process elimination	Non-Cr plating, anodizing
Cd elimination	Cd plating alternative adoption
Pb elimination from anti-fretting coatings	Pb-free alternatives
VOC reduction	Low VOC topcoats, sealants, etc.
Beryllium reduction, mitigation	Alternative materials (coated powders), isolation coatings
Whisker reduction from electronics	Solder modifications, mitigation coatings and treatments

Data-based decisions

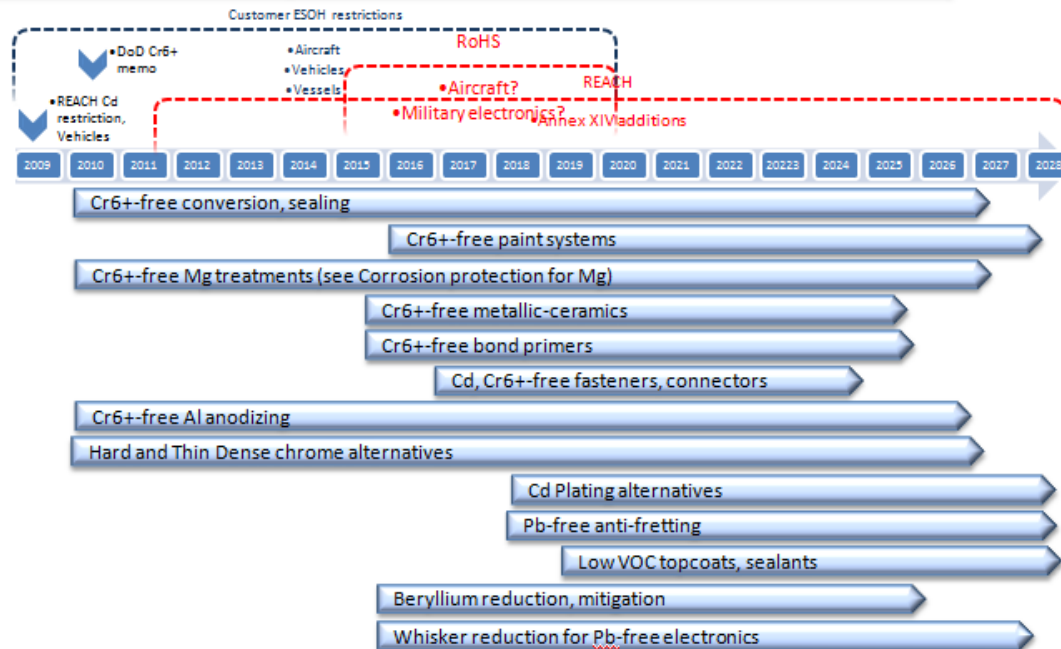

Combined with Technology Analysis of requirements and readiness, Roadmaps can be a useful tool to understanding current technologies and gaps

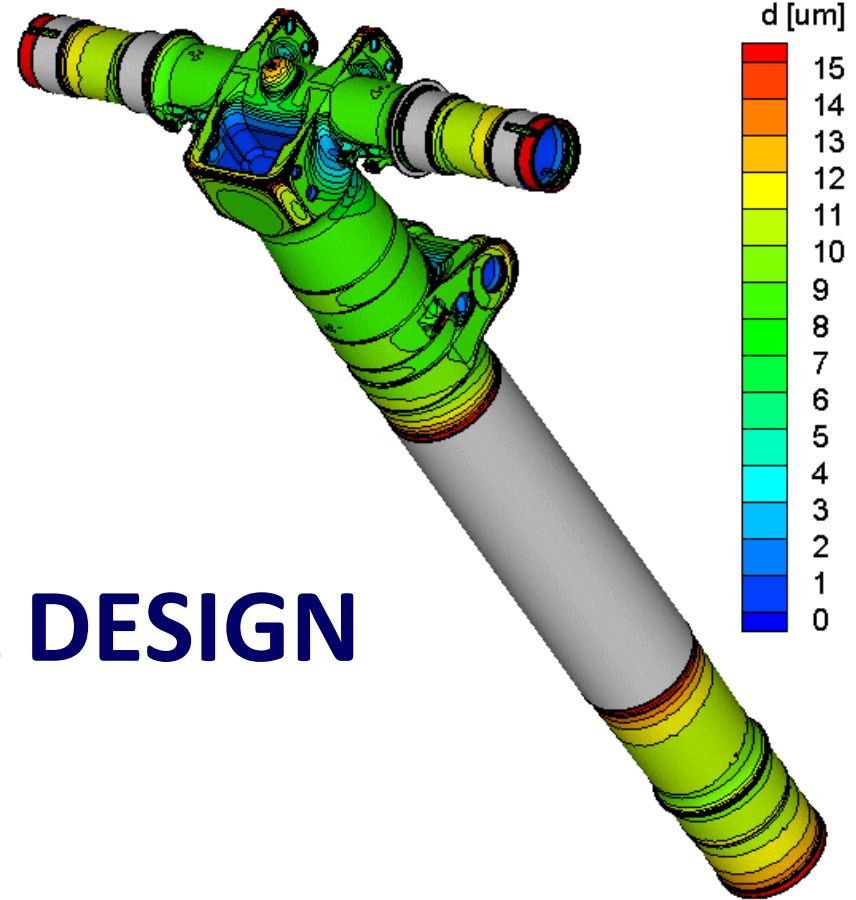

# COMPUTATIONAL DESIGN

Distribution A – Distribution unlimited

Computational design

- Materials by Design™ (vs Materials by Luck)
- Databases and computational methods now permit us to design alloys from scratch
  - Development time months instead of years
  - Now being used for new alloy designs (e.g. CuBe alt)
  - Developed S53 landing gear steel, ASTM 5922
    - ◆ Came within a few % of targets right out of the box
    - ◆ Normal development would have taken several years



### 300M and Ferrrium S53 A-basis *Minimum* Longitudinal Properties:

	UTS (ksi)	YS (ksi)	EI. (%)	RA (%)	Fcy (ksi)	Fsu (ksi)	Kic (ksi√in)
300M	280	230	8	30	247	162	--
S53	280	213	11	44	245	176	50

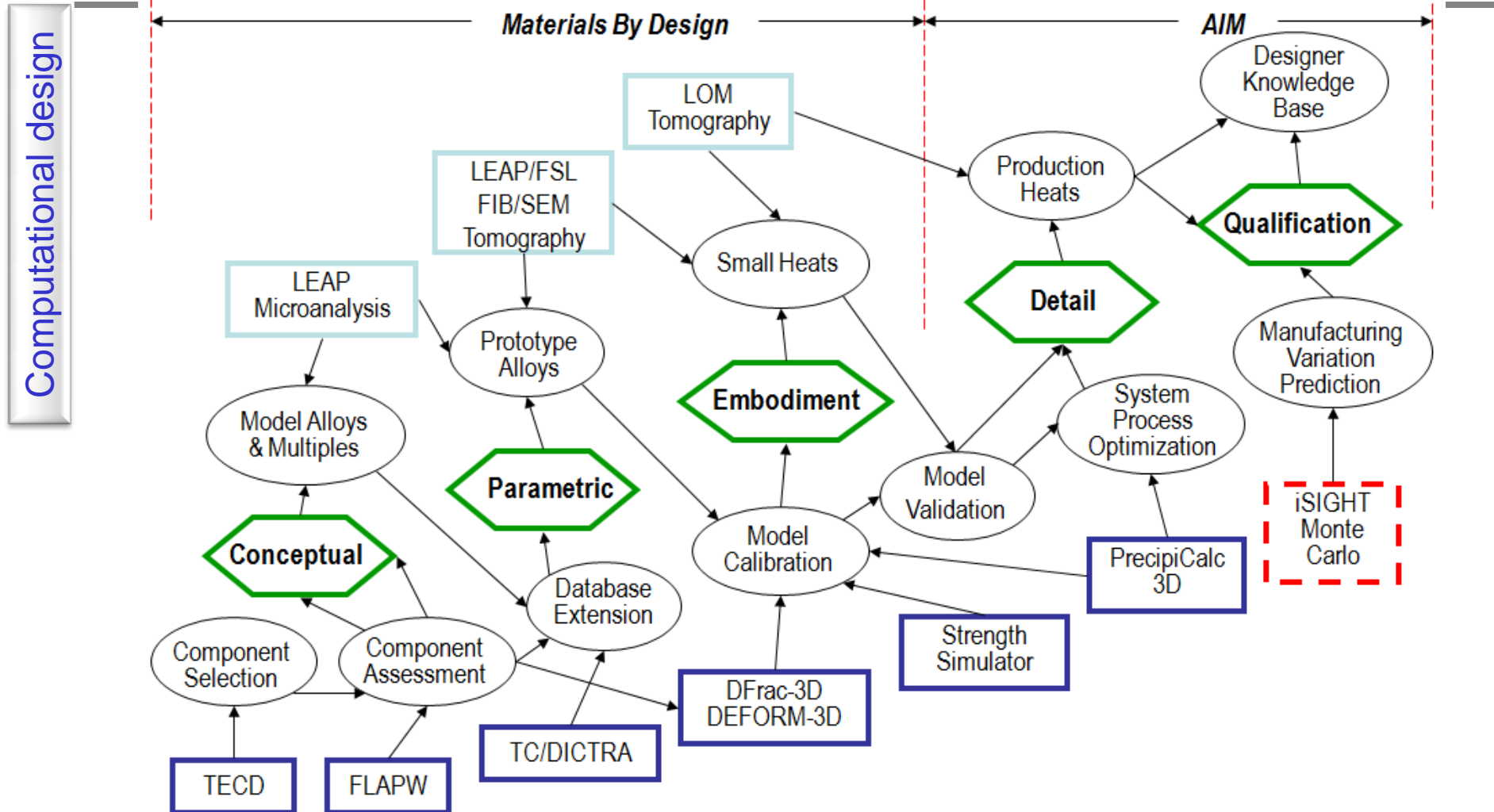

- Accelerated Insertion of Materials
  - ❑ Computational methods also let us get “virtual test data” to fill in the gaps
  - ❑ If you design computationally you can link back into the test data to interpolate and extrapolate
  - ❑ Does not reduce data for A-allowables, but reduces test data needed for engineering
- Because coatings not thermodynamic equilibrium materials difficult to model
  - ❑ **Need to develop computational methods for coatings**

- Successful use of computational methods also means that they must be integrated into the design software
- Design engineers currently use FEA for stress analysis, heat transfer, etc.
- New databases with CAD integration allow the designer to include performance of coatings, galvanic coupling, etc.
  - These new databases also provide the information needed for regulatory compliance

Granta databases now combine alloy, composite, coating and surface treatment data, and ESOH compliance info. Integrate with CAD software via standard data Gateway

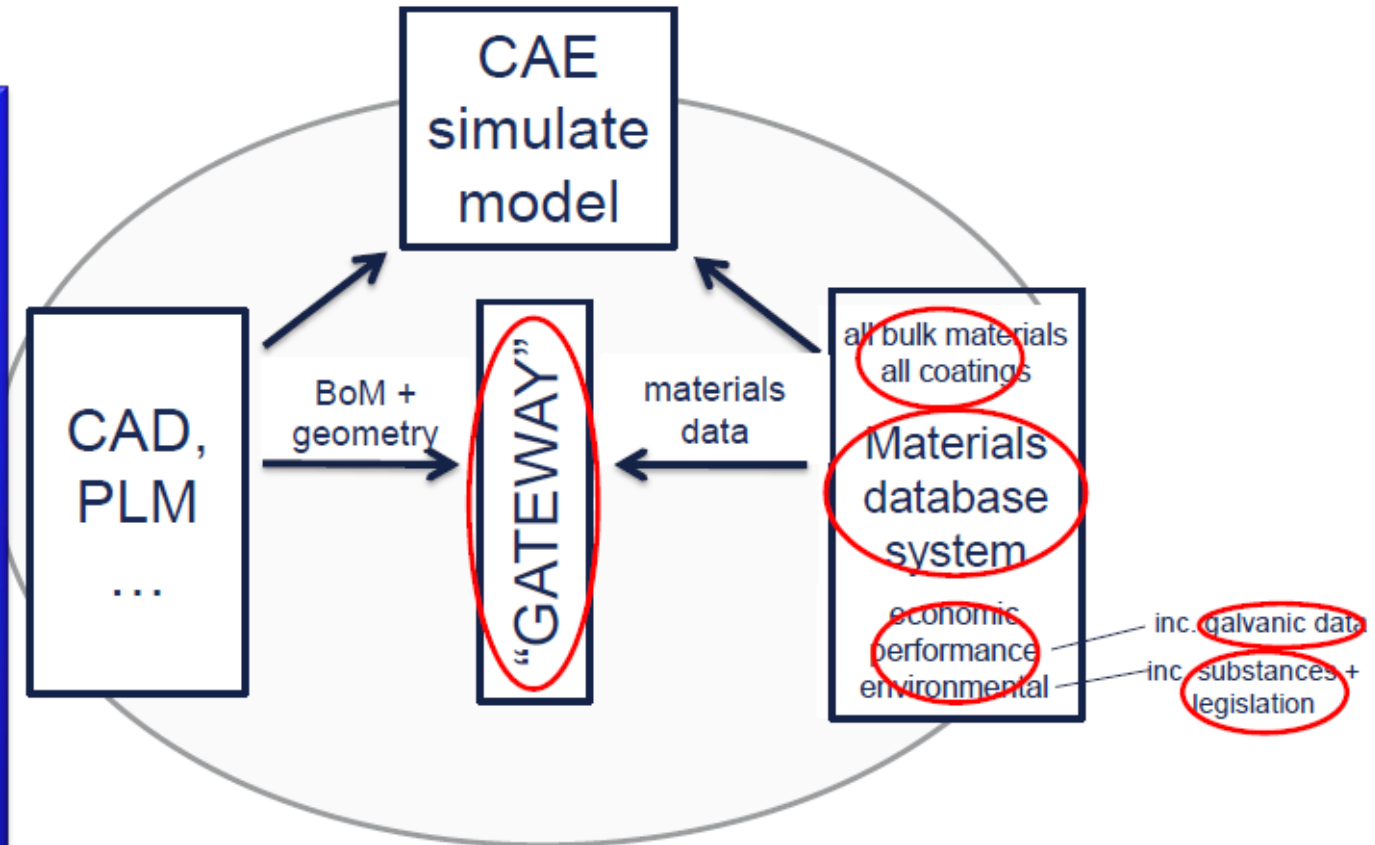

- Galvanic corrosion between disparate metals and coatings is still a major problem
  - There is a reason we have Ni-Cd batteries
  - The Ni-Mg battery is even better!
- Even bigger problem with new materials to save weight, meet ESOH requirements
  - C-fiber composites, Ti – very cathodic
  - ZnNi (cathodic), electroless nickel-PTFE coatings (anodic)
  - Chromate free conversion coatings/sealers
  - Metal flake-loaded gap fillers
- New software calculates corrosion rates by solving electrochemical equations
  - Does not yet take into account effects of corrosion, but permits non-expert to identify design problems

# Using computational galvanic design to make the right choices

Computational design

What if you connect an EN plated plug to a ZnNi plated socket?

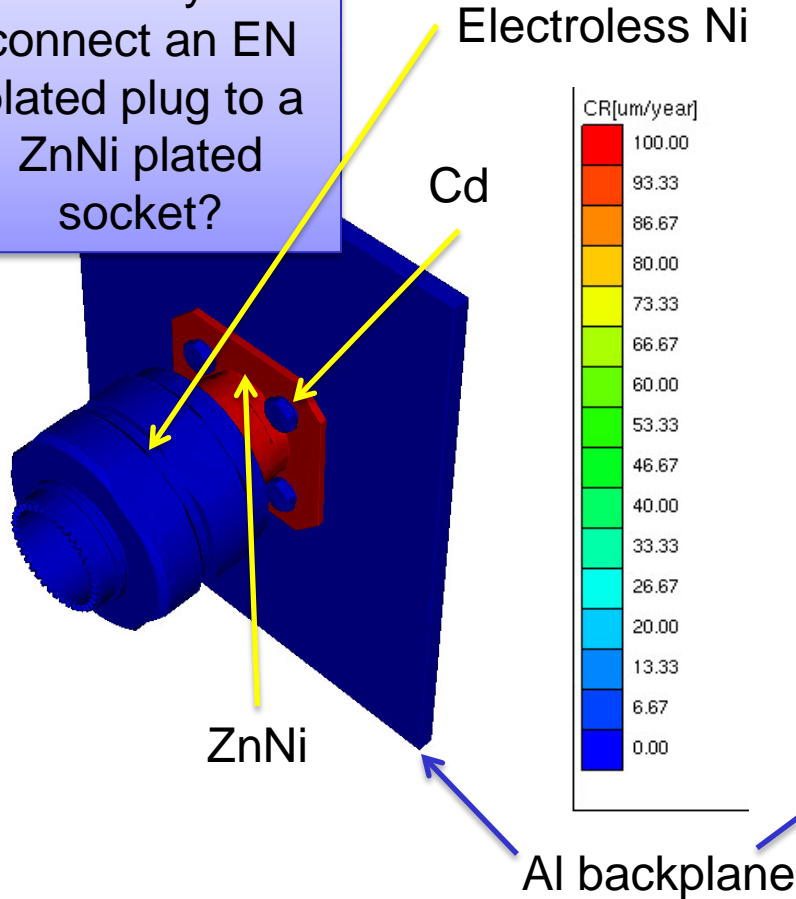

Left: ZnNi on socket corrodes to protect electroless Ni on connector

Right: Al backplane corrodes right at socket

You can quickly “test” many scenarios risk-free

What if water accumulates around connector, not over whole backplane as in B117?

# New materials require new materials data

- Existing data often half a century old
- Older coatings often lack critical data so we do not know what properties alternatives need
- Little or no reliable data on many new materials
  - Especially such information as galvanic data on new coatings with non-chromate finishes
  - Very limited data available for Cd alternatives and non-Cr<sup>6+</sup> sealers

Measurement conditions often not relevant to how data are used

- Galvanic chart 50+ year old data only for older alloys in flowing seawater, no new alloys and finishes in quiescent salt water relevant to aircraft

**We need reliable data for all our materials and treatments**

SATURATED CALOMEL HALF CELL REFERENCE ELECTRODE

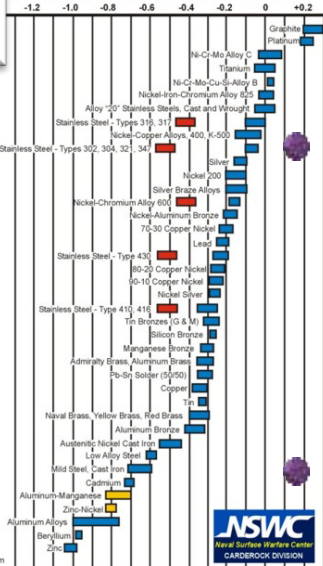

# Computational design is only as good as the data it depends on

Computational design

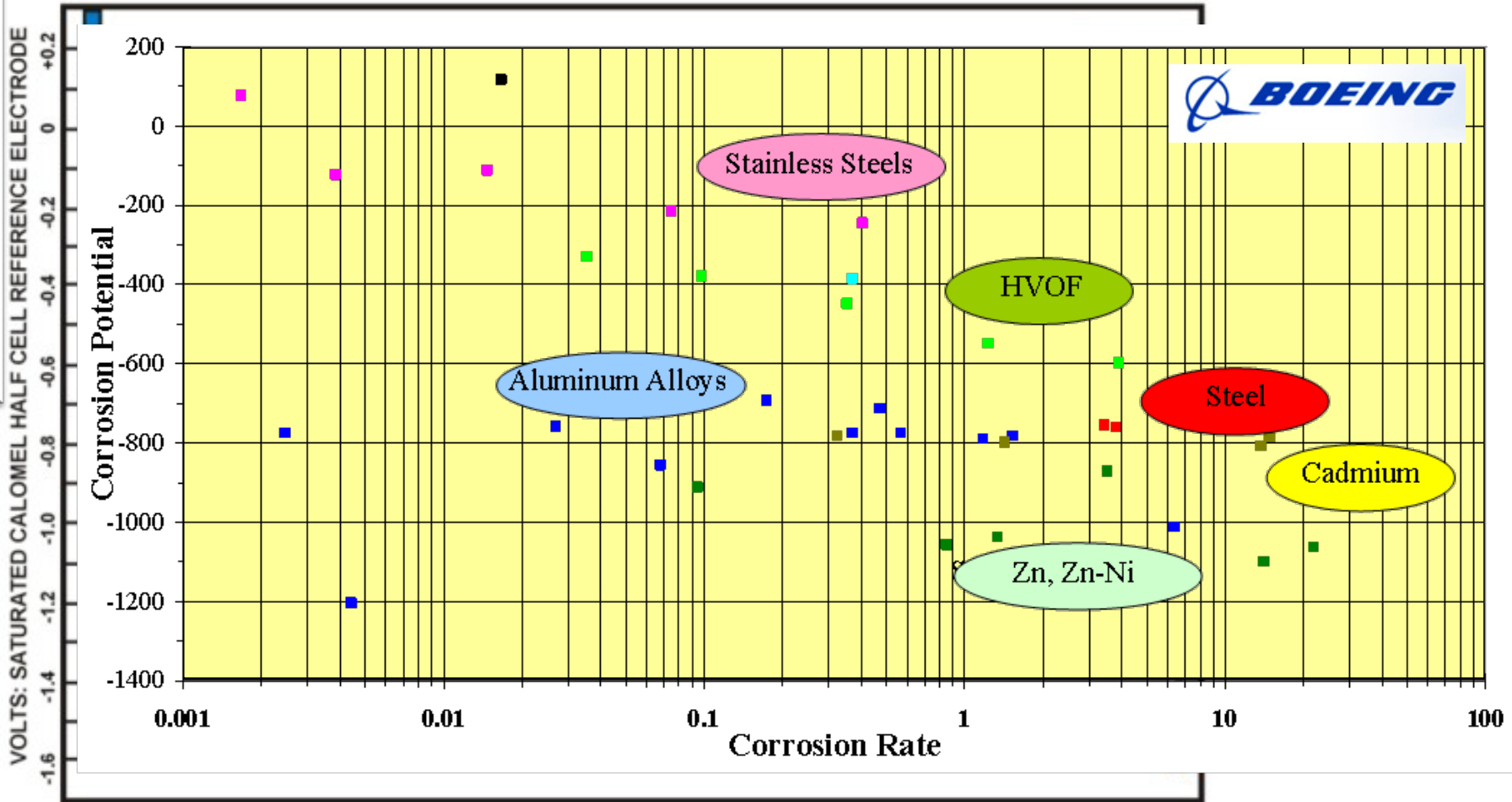



# ACCELERATED TESTING

- Most existing performance tests were developed for existing (old) products
  - Many new products work in a completely different way and often fail existing tests
    - ◆ Example – non-Cr<sup>6+</sup> conversion coatings
- Most requirements state that any alternative must be “equal to or better than” the existing material
  - The only material that meets that requirement in every test is the existing material – excuse not to change
- Tests we use for qualification are often explicitly not designed for that, but they are all we have
  - E.g. ASTM B117 for corrosion, F519 for embrittlement
- **We need true performance tests based on real service requirements, rather than tests that simply compare with older materials**

- The slowest types of testing are
  - ❑ Corrosion – typical 2,000 hr salt fog, one year beach exposure test
  - ❑ Service evaluation – typical one or more carrier tours of duty, one or more years flight test
  - ❑ Endurance and wear testing – often several months
- We have accelerated test methods, but their relevance is questionable at best
  - ❑ B117 salt fog
  - ❑ Ring-on-block wear test
- **We need short-duration tests that accurately predict long-duration real-life performance**

- Everyone agrees B117 not representative, was never intended for qualification
- Two SERDP projects to devise better tests
  - [WP-1673](#), trying to design a method that includes all the variables that drive corrosion
    - ◆ Mimics the causes
  - [WP-1674](#), trying to mimic in the lab the chemical changes we see in the field
    - ◆ Mimics the effects
- [NAVAIR method](#) combines short B117 or G85 with short beach test using galvanic assemblies
  - E.g. 500 hr B117 + 7 month beach

● USMC uses Accelerated Corrosion Durability Road Test (ACDRT) at Aberdeen Test Ctr

- ❑ Uses LRIP vehicle
- ❑ Daily driving cycle to match service conditions
- ❑ Designed to be equivalent to 22 yrs service
- ❑ Tear-down and evaluation
- ❑ Easy to do with vehicles – a little more difficult and expensive with ships and aircraft!



- With rational use of databases, computational tools, and technology analysis we can greatly reduce the development cycle
  - ❑ Using databases rather than reinventing the wheel
  - ❑ Meaningful, predictive tests that work for new materials
  - ❑ Valid performance data for new materials and coatings
  - ❑ Computational design methods for materials
  - ❑ Materials databases and modeling integrated with CAD for error-free design

