

Experimental Characterization and Validation of Simultaneous Gust Alleviation and Energy Harvesting for Multifunctional Wing Spars

AFOSR # FA9550-09-1-0625

Ya Wang¹ and Daniel J. Inman² Department of Aerospace Engineering

University of Michigan

e-mail daninman@umich.edu

¹ Postdoctoral Researcher ² Professor and Chair



AEROSPACE ENGINEERING

Report Documentation Page

*Form Approved
OMB No. 0704-0188*

Public reporting burden for the collection of information is estimated to average 1 hour per response, including the time for reviewing instructions, searching existing data sources, gathering and maintaining the data needed, and completing and reviewing the collection of information. Send comments regarding this burden estimate or any other aspect of this collection of information, including suggestions for reducing this burden, to Washington Headquarters Services, Directorate for Information Operations and Reports, 1215 Jefferson Davis Highway, Suite 1204, Arlington VA 22202-4302. Respondents should be aware that notwithstanding any other provision of law, no person shall be subject to a penalty for failing to comply with a collection of information if it does not display a currently valid OMB control number.

1. REPORT DATE AUG 2012	2. REPORT TYPE	3. DATES COVERED 00-00-2012 to 00-00-2012			
4. TITLE AND SUBTITLE Experimental Characterization and Validation of Simultaneous Gust Alleviation and Energy Harvesting for Multifunctional Wing Spars		5a. CONTRACT NUMBER			
		5b. GRANT NUMBER			
		5c. PROGRAM ELEMENT NUMBER			
6. AUTHOR(S)		5d. PROJECT NUMBER			
		5e. TASK NUMBER			
		5f. WORK UNIT NUMBER			
7. PERFORMING ORGANIZATION NAME(S) AND ADDRESS(ES) University of Michigan, Department of Aerospace Engineering, Ann Arbor, MI, 48109		8. PERFORMING ORGANIZATION REPORT NUMBER			
9. SPONSORING/MONITORING AGENCY NAME(S) AND ADDRESS(ES)		10. SPONSOR/MONITOR'S ACRONYM(S)			
		11. SPONSOR/MONITOR'S REPORT NUMBER(S)			
12. DISTRIBUTION/AVAILABILITY STATEMENT Approved for public release; distribution unlimited					
13. SUPPLEMENTARY NOTES Presented at the 2nd Multifunctional Materials for Defense Workshop in conjunction with the 2012 Annual Grantees'/Contractors' Meeting for AFOSR Program on Mechanics of Multifunctional Materials & Microsystems Held 30 July - 3 August 2012 in Arlington, VA. Sponsored by AFRL, AFOSR, ARO, NRL, ONR, and ARL. U.S. Government or Federal Rights License					
14. ABSTRACT					
15. SUBJECT TERMS					
16. SECURITY CLASSIFICATION OF:			17. LIMITATION OF ABSTRACT Same as Report (SAR)	18. NUMBER OF PAGES 29	19a. NAME OF RESPONSIBLE PERSON
a. REPORT unclassified	b. ABSTRACT unclassified	c. THIS PAGE unclassified			

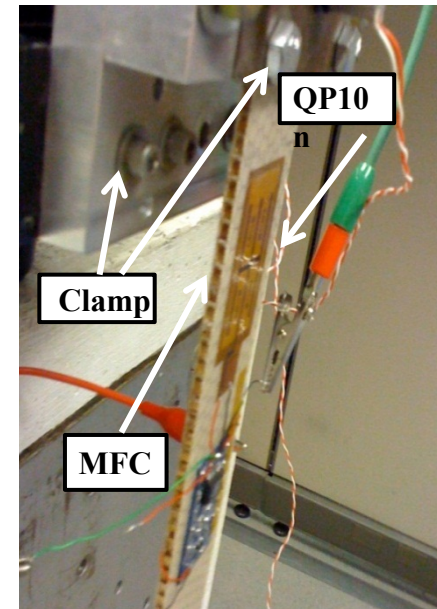
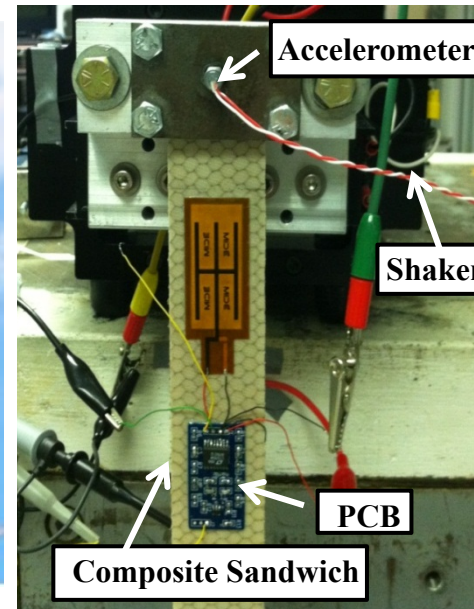

Research Issues:

1. Characterization of appropriate ambient energy
2. Characterization of sensing, harvesting, actuation, associated electronics
3. Validation of reduced energy control laws with limited energy
4. Validation of autonomous gust alleviation system



AEROSPACE ENGINEERING

Experimental Characterization of Transduction Abilities



Experimental Setup for Transduction Characterization of QP and MFC

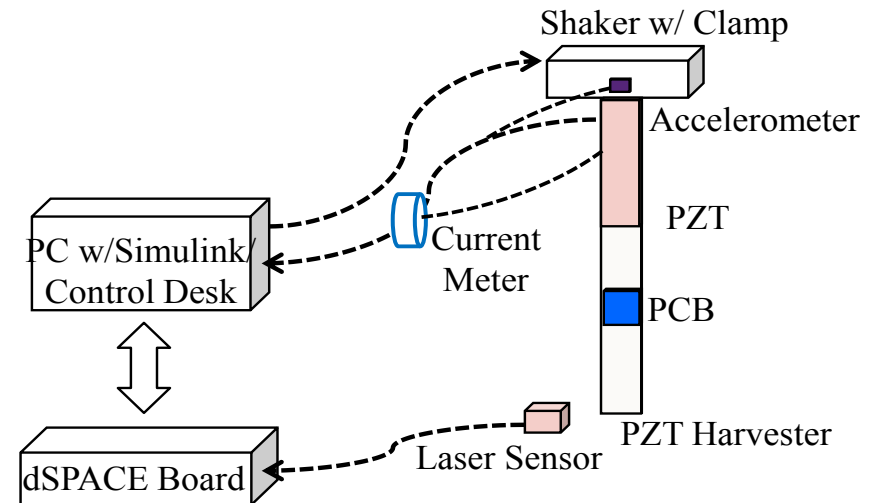
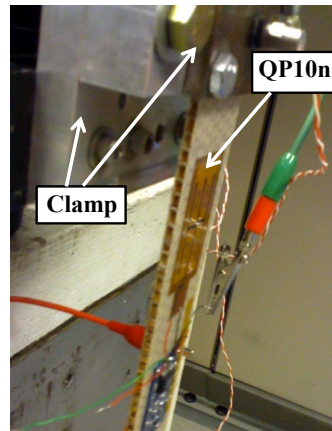
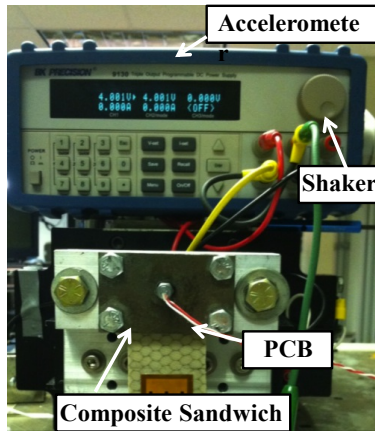

Which is the best transducer?
What is the coupling coefficient?
What is the internal capacitance?

Property/Component	QP10n	MFC8528P1	Composite Substrate
Overall Length	50.8 mm	112 mm	593.7mm
Overall Width	25.4 mm	40 mm	38mm
Overall Thickness	0.508 mm	0.18 mm	3.175mm
Overall Mass	2.835 gram	4.06 gram	13.97gram
Nominal Distance	34.5 mm	34.5 mm	N/A

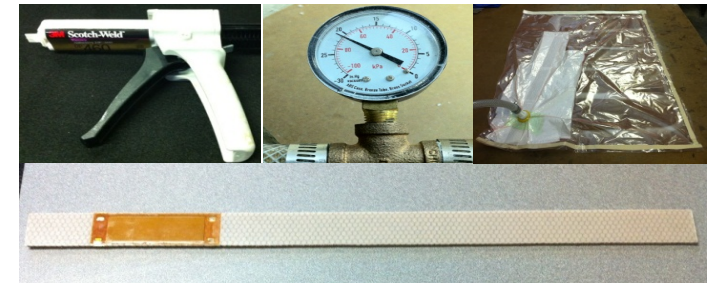
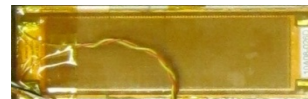
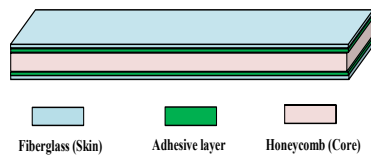

Simulations of Normal Vibration and Wind Gust

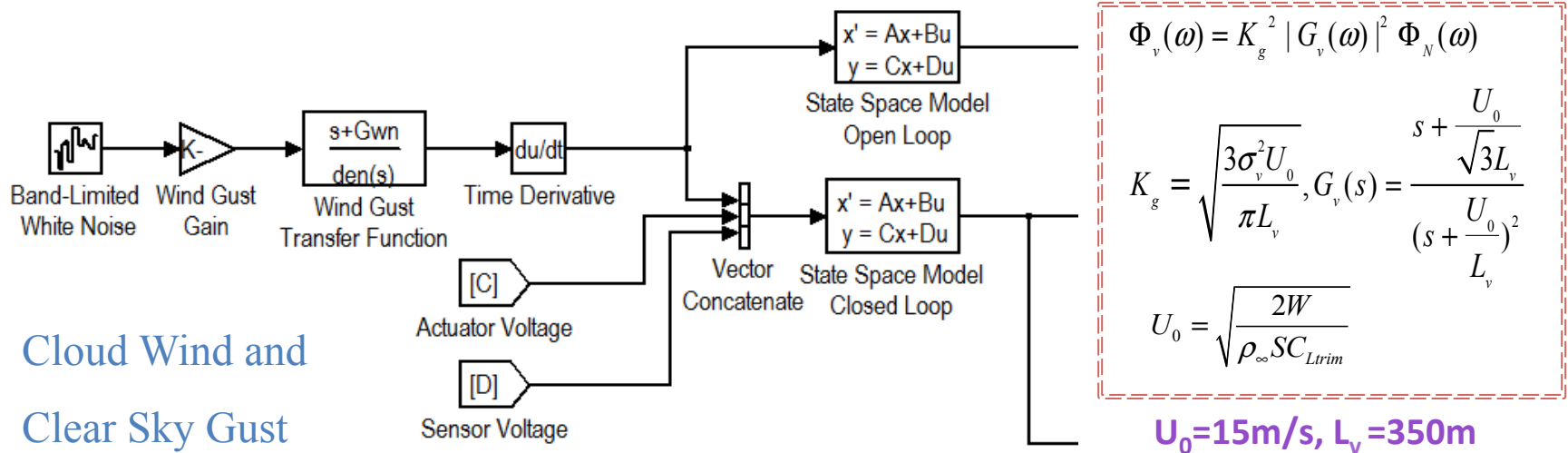

Cloud Wind and
 Clear Sky Gust
 Simulation Using
 Dryden PSD*
 Harvested Energy
 from Normal
 Vibration (Red) to
 Control Wind Gust
 Disturbance (blue)

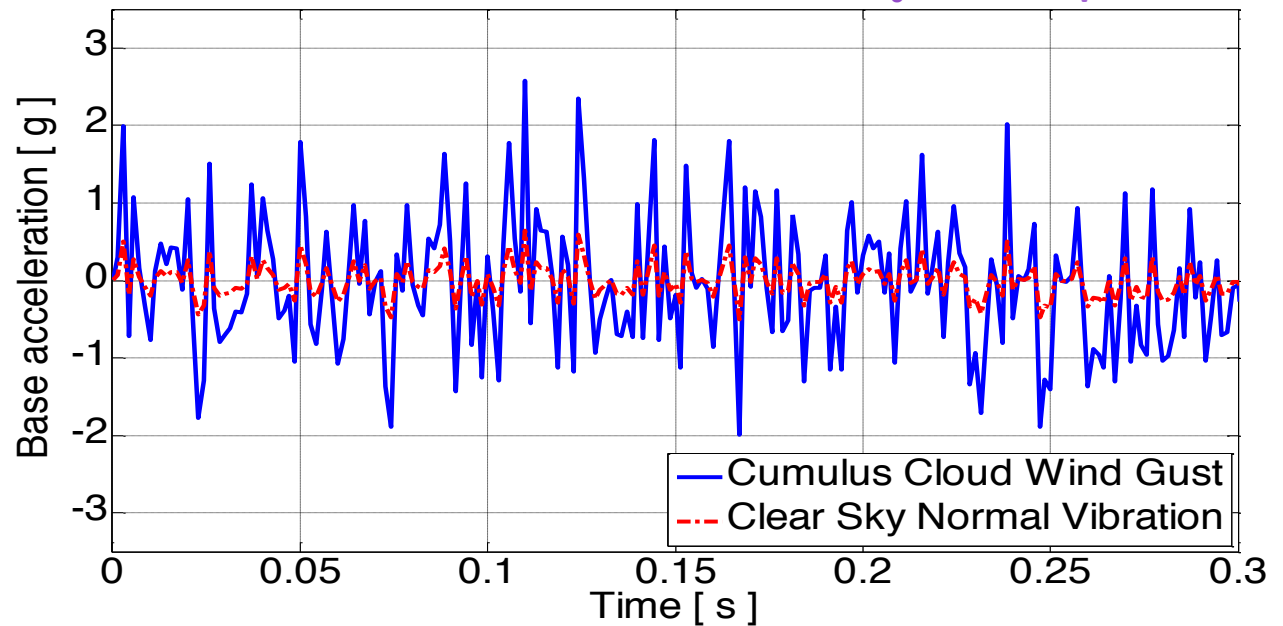

AEROSPACE ENGINEERING

Ref: *McLean, D, 'Automatic Flight Control System', Prentice Hall, 1990

Validation of QP 10N Two Mode Harvesting

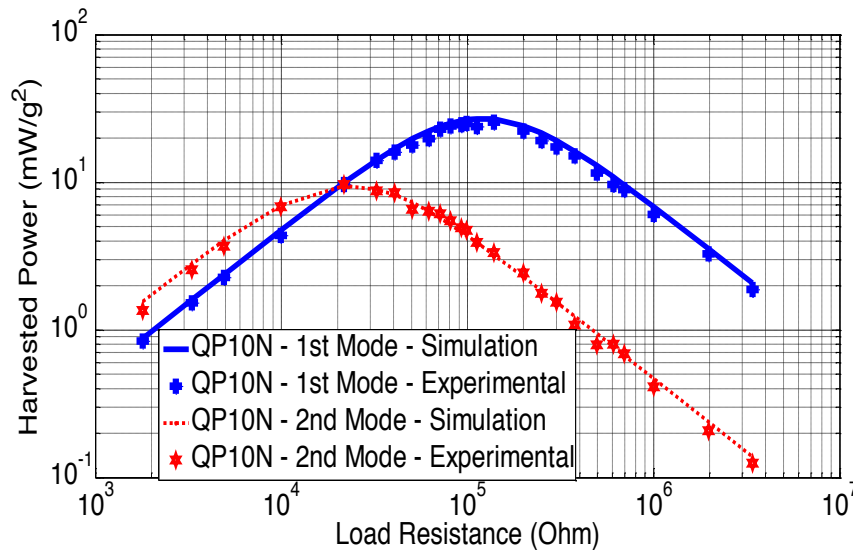
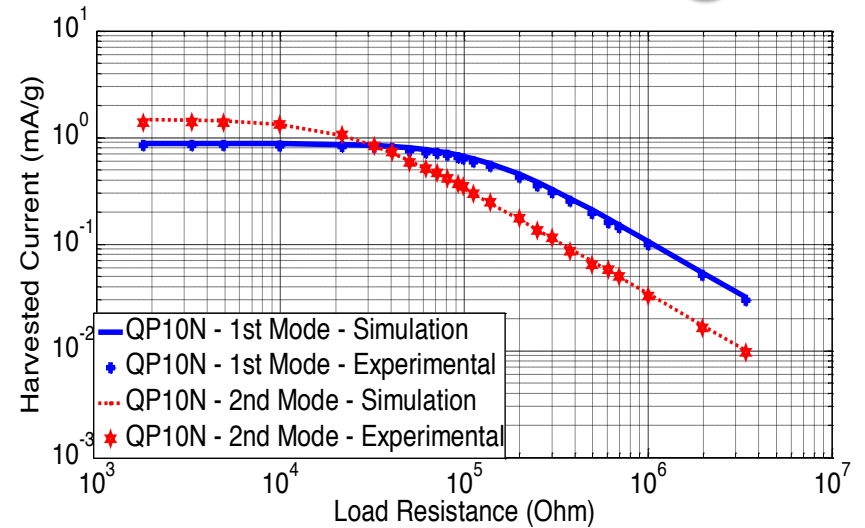
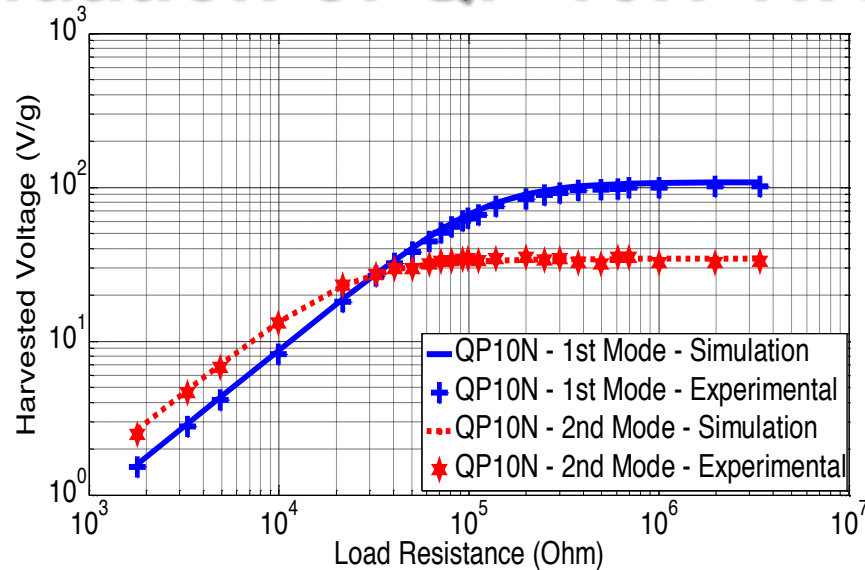

Peak Power Amplitude [QP]:

28.2mW/g² 1st mode @ 112kΩ

9.8mW/g² 2nd mode @ 20.2kΩ



AEROSPACE ENGINEERING

Validation of MFC Two Mode Harvesting

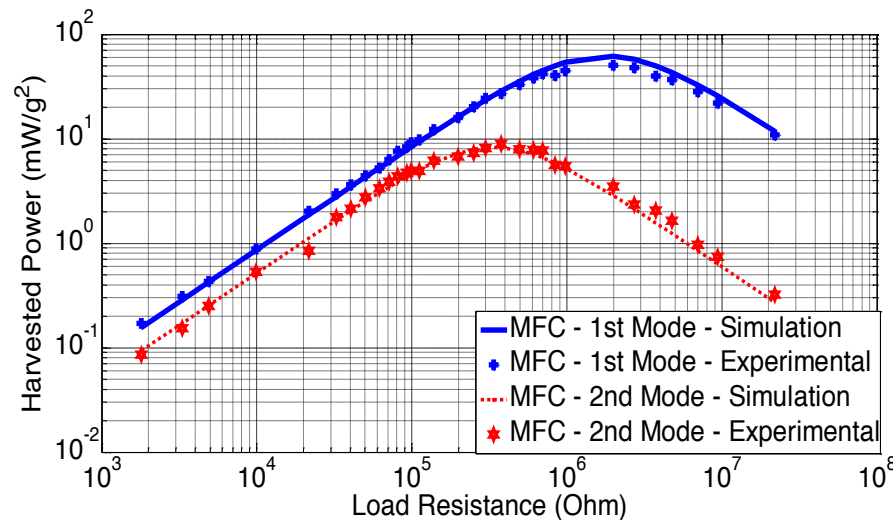
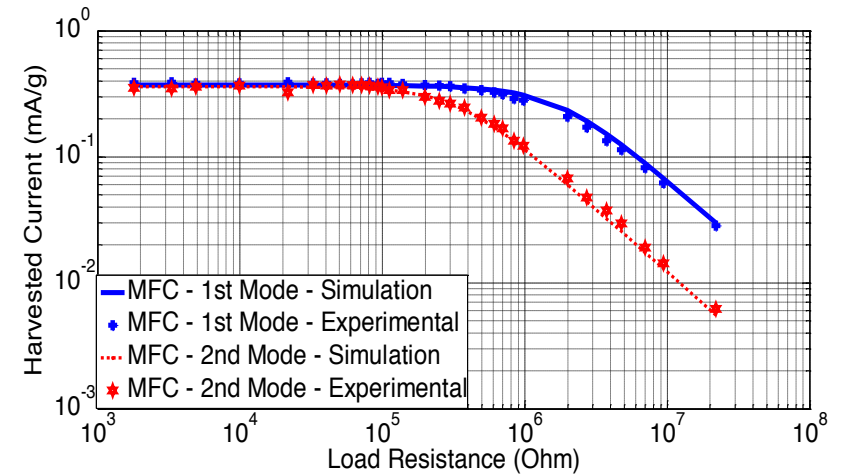
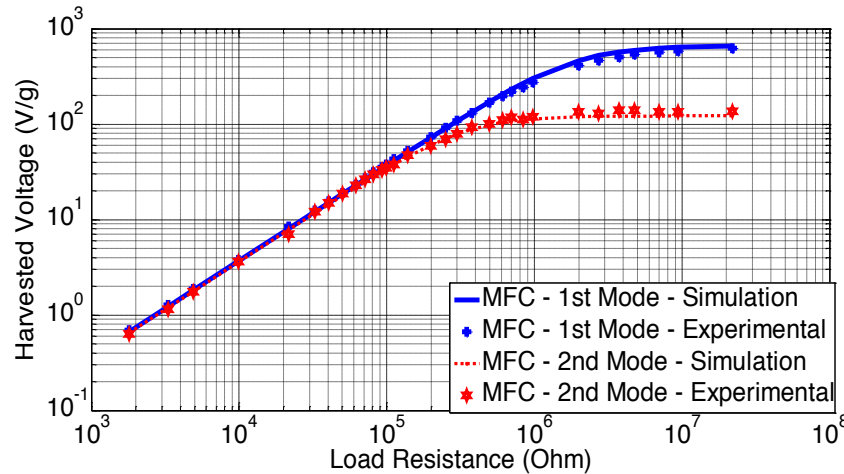

Peak Power Amplitude [MFC]:

50.8 mW/g² 1st mode @ 1.98 MΩ

9.8 mW/g² 2nd mode @ 0.35 MΩ

Looks like MFC is better than QP except not if normalized by active volume of PZT

Experimental Results of Transduction Characterization

Hamilton Principle Equations

$$\int_{t_1}^{t_2} (\delta T_e - \delta U + \delta E_{ie} + \delta E_{nc}) dt = 0.$$

Governing

$$\mathbf{M}\ddot{\eta} + \mathbf{C}\dot{\eta} + \mathbf{K}\eta = \mathbf{f} + \theta^h V^h$$

$$C_p^h \dot{V}^h + i^h + \theta^h \dot{\eta}^h = 0$$

Property/Component	QP10n	MFC8528P1	Composite Substrate
Active Length	45mm	85mm	559.2mm
Active Width	20mm	28mm	38mm
Thickness	0.38mm	0.18mm	3.175mm
Mass	2.30gram	4.06gram	13.97gram
Young's Modulus	51GPa	42GPa	10.29GPa
Internal Capacitance	117nF	7.9nF	N/A
Piezoelectric Coefficient d_{33}	-190e-12	400e-9	N/A
Effective Distance from Clamp	38.4mm	30.5mm	N/A



AEROSPACE ENGINEERING

Transducer data from experimental identification

Optimal length for Harvesting Effectiveness

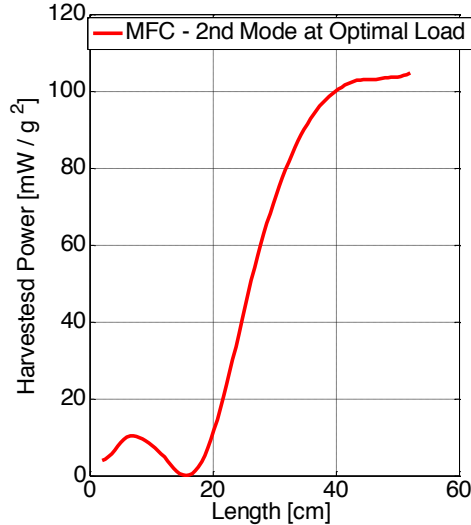
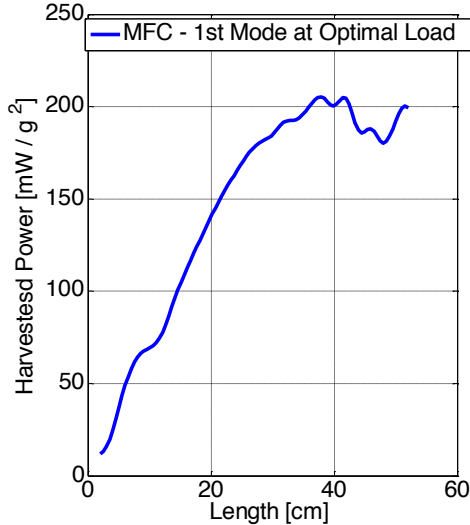

Stewart, Weaver and Cain (2012) reported theoretically and experimentally that harvested energy in the fundamental mode maximized with an active length (electrode coverage) of exactly 2/3 of the beam length from the root.

Output Power of MFC versus Active Length at Mode 1 of 29 Hz and Mode 2 of 107Hz.

Expanded result to the 2nd mode

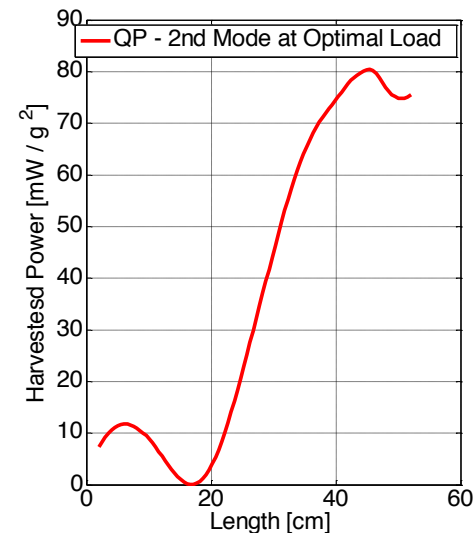
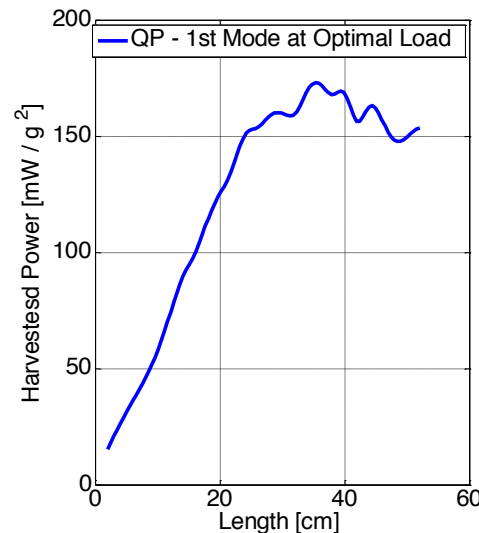

Output Power of QP versus Active Length at Mode 1 of 29 Hz and Mode 2 of 107Hz.

Design Consideration on Harvesting Effectiveness

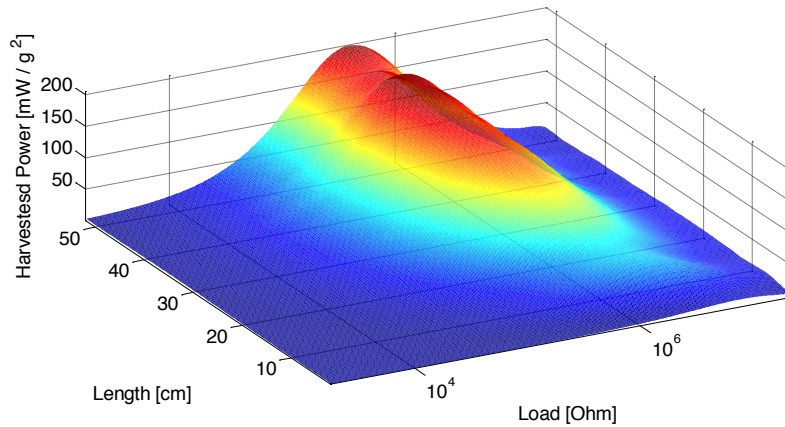

**Power vs. Optimal Load Vs. Length
MFC 8528P1 @ Mode 1 @ 29Hz**

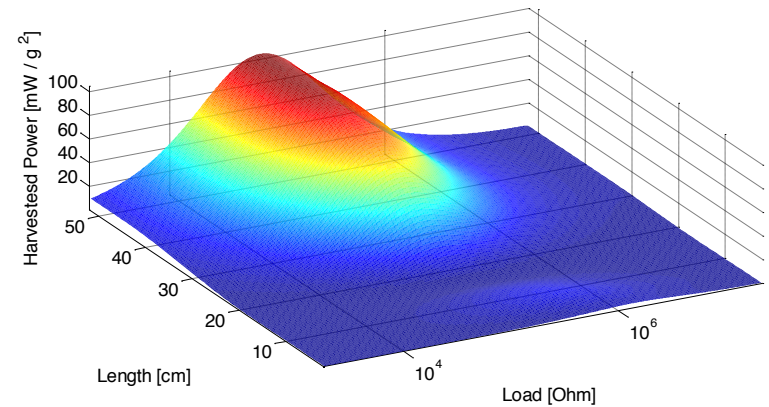

**Power vs. Optimal Load Vs. Length
MFC 8528P1 @ Mode 2 @ 107Hz**

Devices	MFC 8528P1
active length x width	85mm x 28 mm
thickness	0.18mm
mass	4.06g
elastic modulus	42GPa
operating mode	{3-3}
capacitance	5.7nF
pzt constant d31/d33	400pC/N
coupling coefficient J _n	8.9e-5

Simulations to compare power with active sensing length, load resistance for an MFC Sensor

Design Consideration on Harvesting Effectiveness

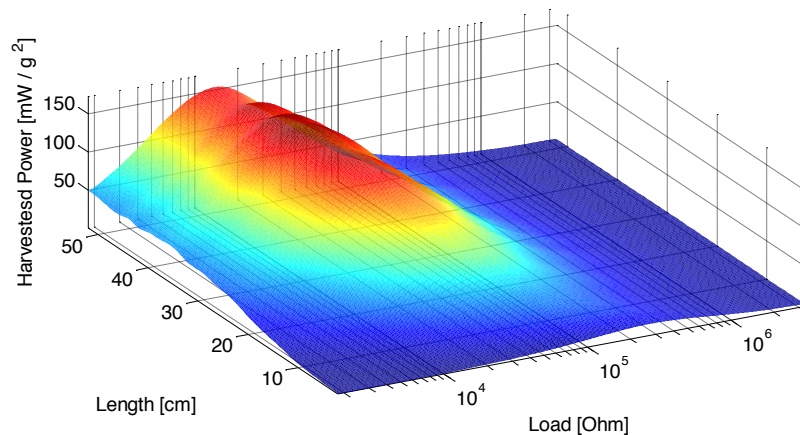

**Power vs. Optimal Load Vs. Length
QP10n @ Mode 1 @ 29Hz**

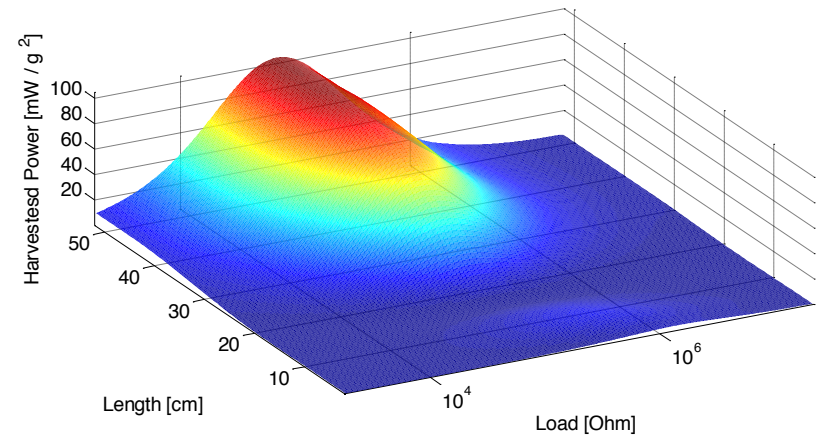

**Power vs. Optimal Load Vs. Length
QP10n @ Mode 1 @ 29Hz**

Devices	QP10n
active length x width	45mm x 25.4mm
thickness	0.38mm
mass	2.3g
elastic modulus	51Gpa
operating mode	{3-1}
capacitance	117nF
pzt constant d31/d33	-190pC/N
coupling coefficient J _n	-4.4e-4

Simulations to compare power with active sensing length, load resistance for an QP Sensor

Experimental Validation of Reduced Energy Control



AEROSPACE ENGINEERING

Experimental Setup for Reduced Energy Control via MFC

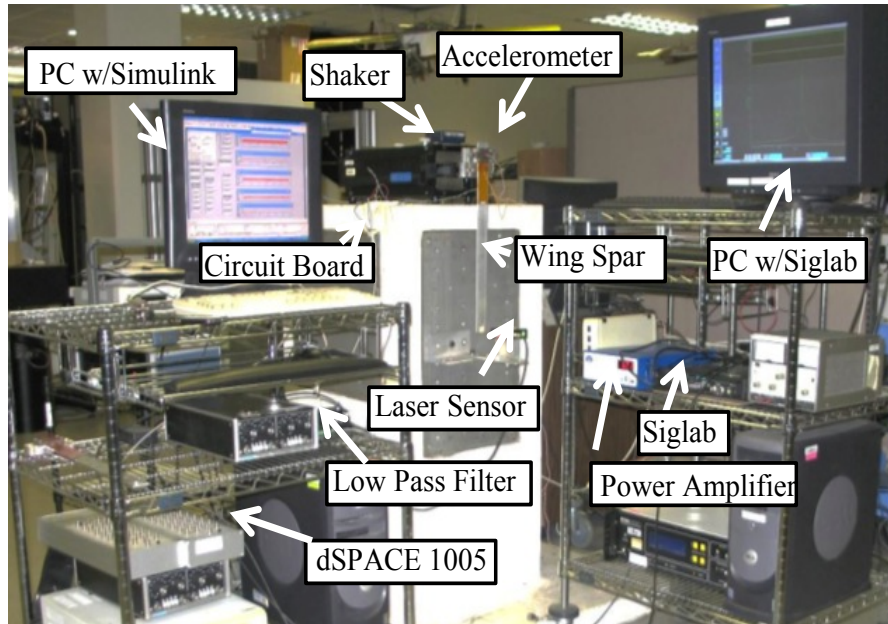

Property/Component	MFC	Al Substrate
Clamped Length	112mm	450mm
Width	40mm	28mm
Thickness	0.18mm	3.05mm
Mass	4.06g	139.4g

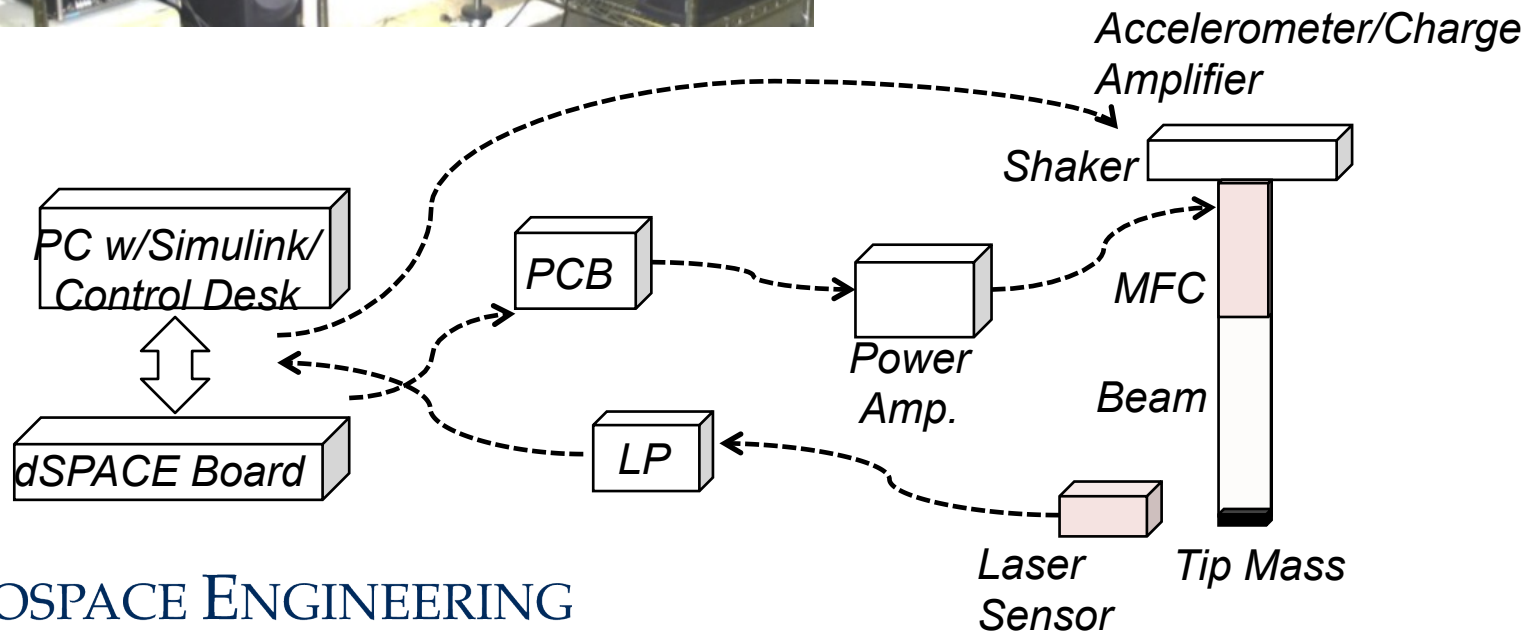

Reduced Energy Control Laws

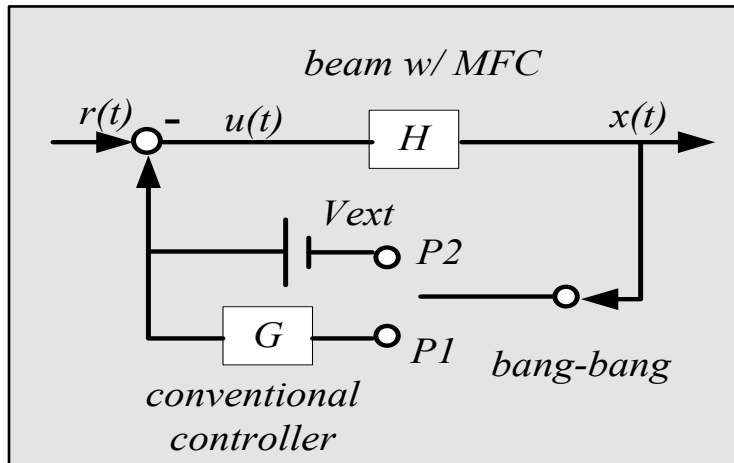

Case I: $u(t) > 0$

If $u(t) < V_{ext}$, connect to P1, then $u = u(t)$;

if $u(t) \geq V_{ext}$, connect to P2, then $u = V_{ext}$;

Case II: $u(t) < 0$

if $u(t) \leq -V_{ext}$, connect to P2, then $u = -V_{ext}$;

if $u(t) > -V_{ext}$, connect to P1, then $u = u(t)$.

Design Methodology:

Cut off higher levels of actuation voltage by saturating control sources;

Reduce the average actuation power input flowing into

piezoceramic actuator until control performance is reached

Experimental Characterization of Control Performance

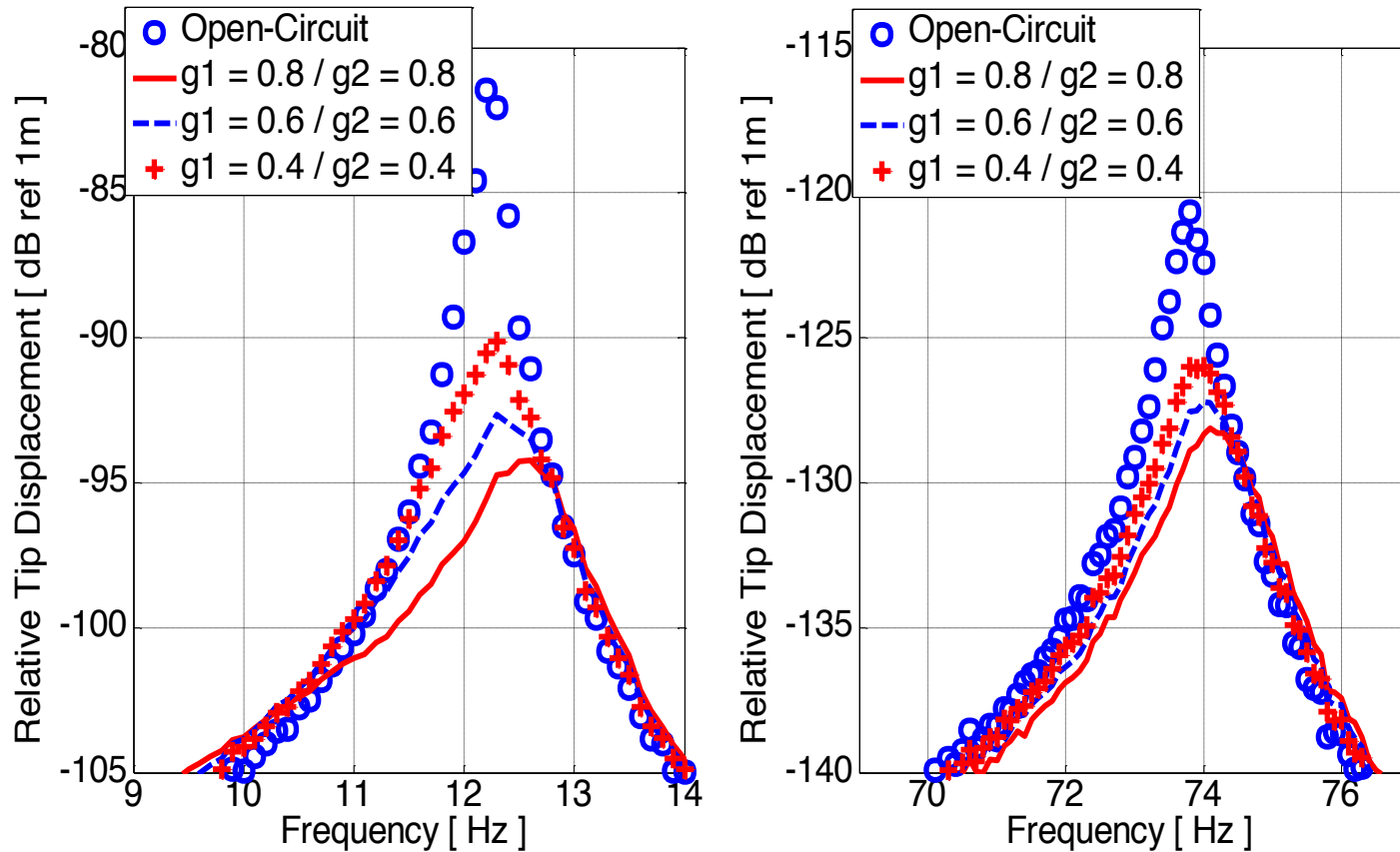

damping ratio of mode 1: $\zeta_1 = 0.15$ and mode 2: $\zeta_2 = 0.35$

1st Mode Control Gain	0.8	0.6	0.4
2nd Mode Control Gain	0.8	0.6	0.4
1st Mode Reduction	13dB	11dB	9dB
2nd Mode Reduction	8dB	7dB	6dB



Experimental Characterization of Control Performance

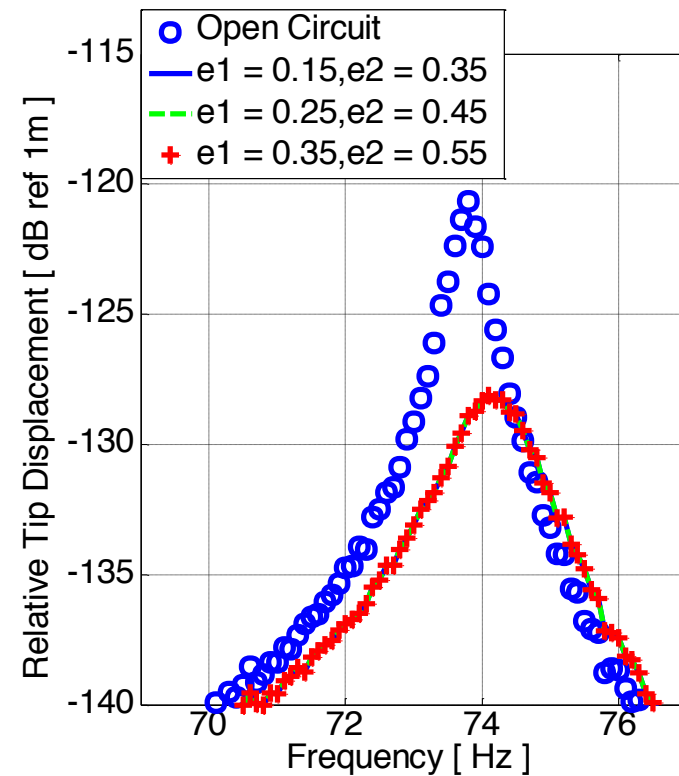
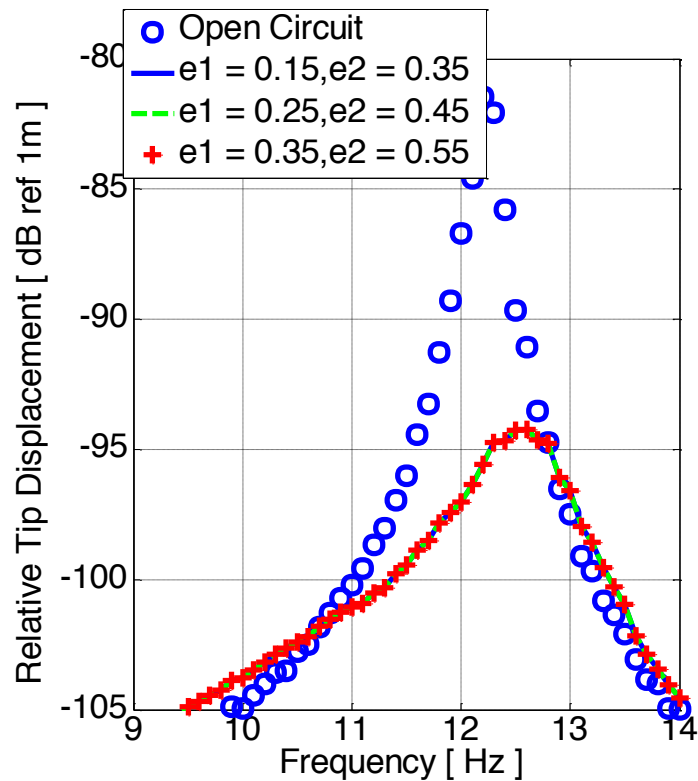

damping ratio of mode 1: $g_1 = 0.6$ and mode 2: $g_2 = 0.6$

Shows that velocity gain in controller does not effect performance

Experimental Comparison of Control Performance

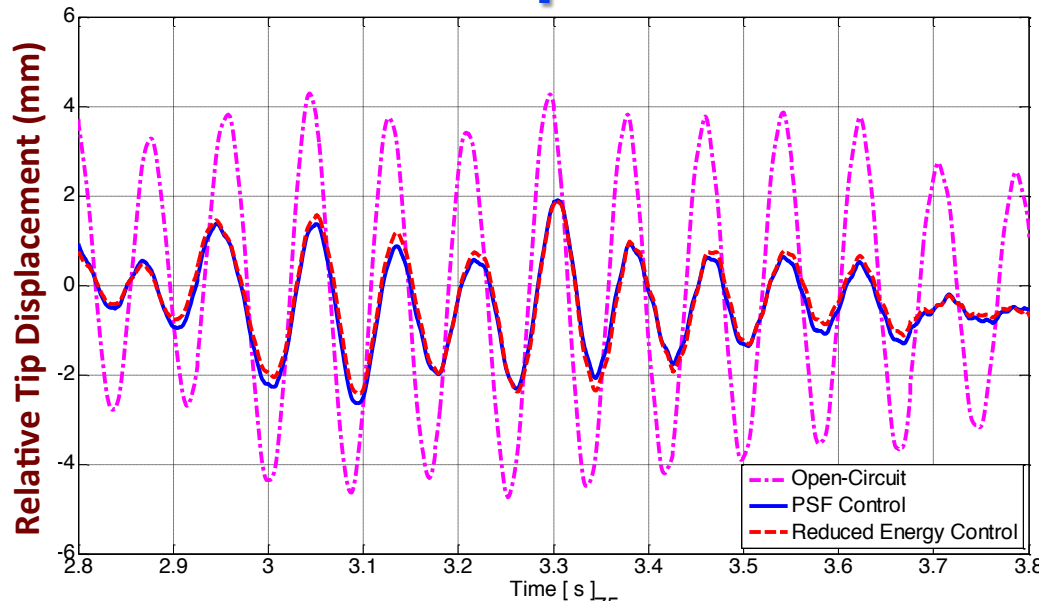

RMS value : 3 mm to 1.2 mm

14 dB reduction for 1st Mode
12 dB reduction for 2nd Mode

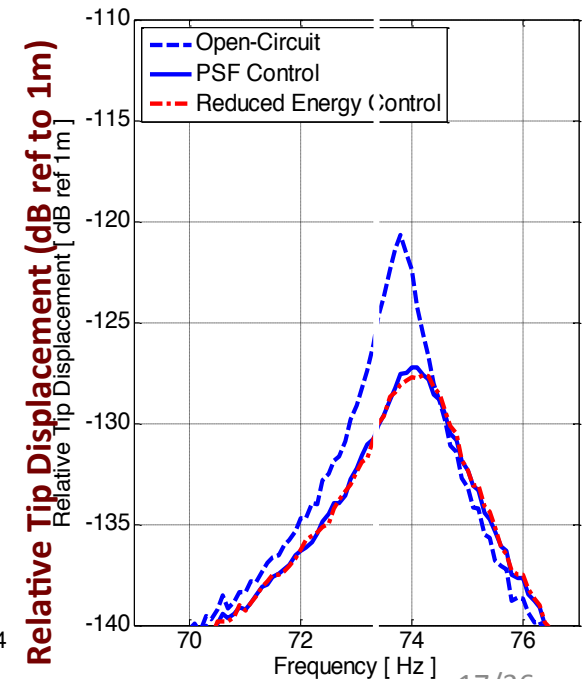
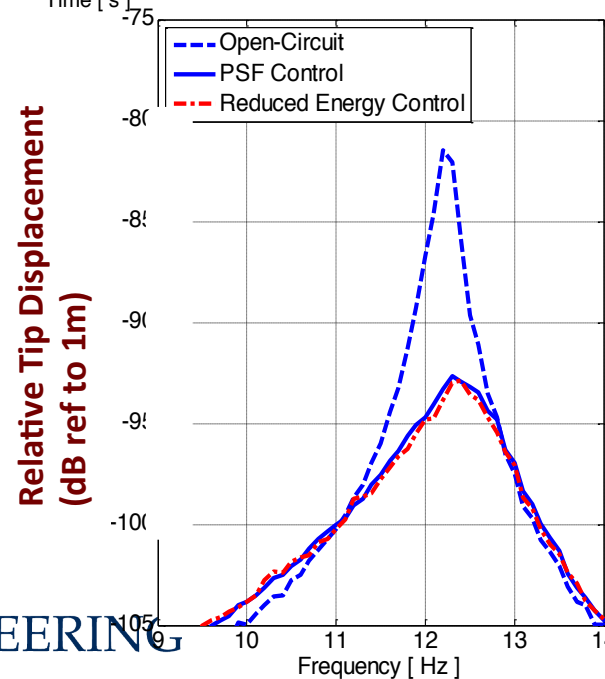

Experimental Comparison: Reduced Energy Control vs. PSF

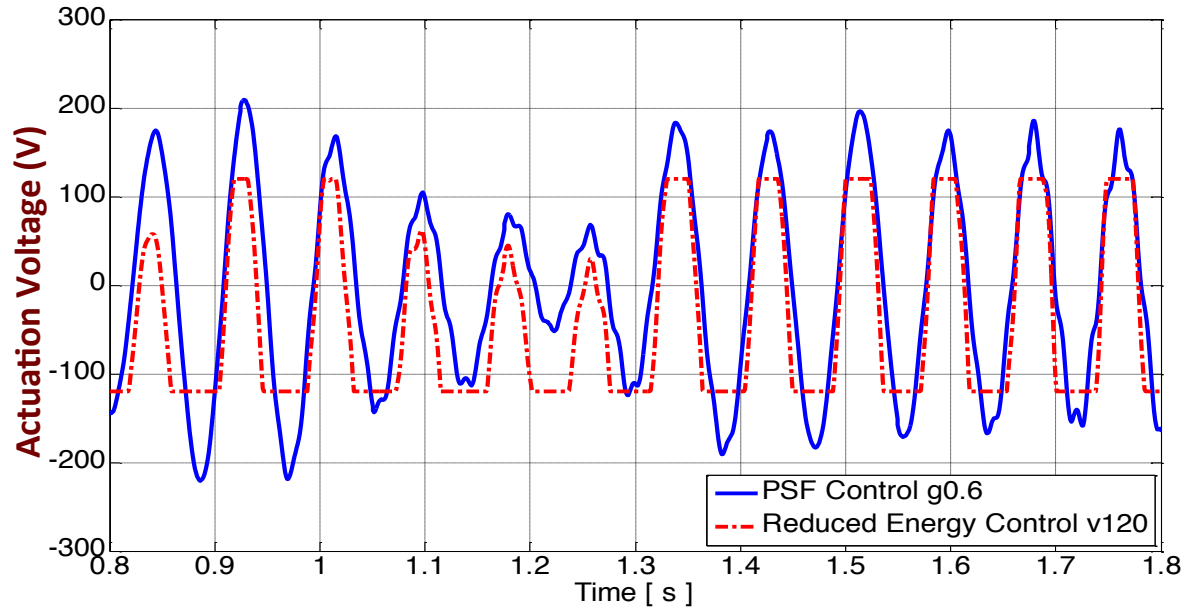

REC cut off
higher levels of
actuation voltage

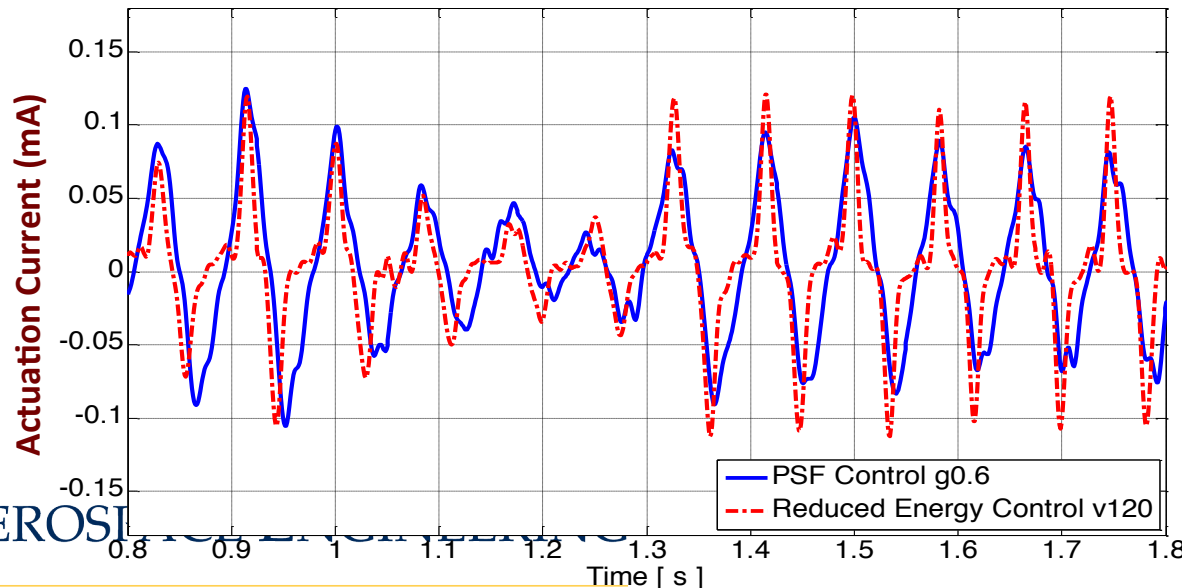

current from REC
has sharp change
while the saturation
occurs, due to the
sharp switching in
voltage, and it drops
down rapidly after
saturation finishes



Schematic Autonomous Gust Alleviation System

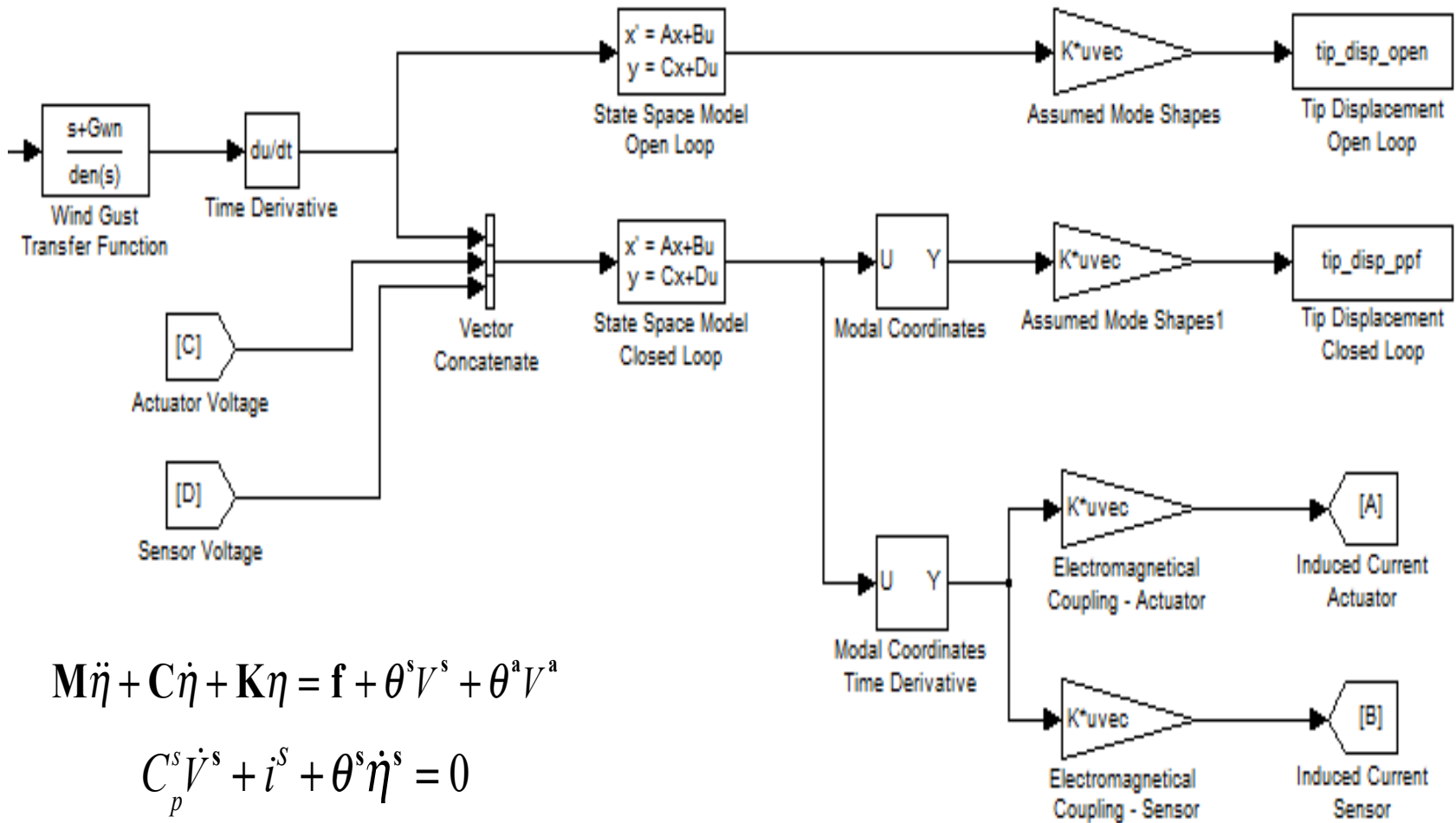

$$M\ddot{\eta} + C\dot{\eta} + K\eta = f + \theta^s V^s + \theta^a V^a$$

$$C_p^s \dot{V}^s + i^s + \theta^s \dot{\eta}^s = 0$$

$$C_p^a \dot{V}^a + i^a + \theta^a \dot{\eta}^a = 0$$

Experimental Comparison of Actuation Power to reach 5% settling time

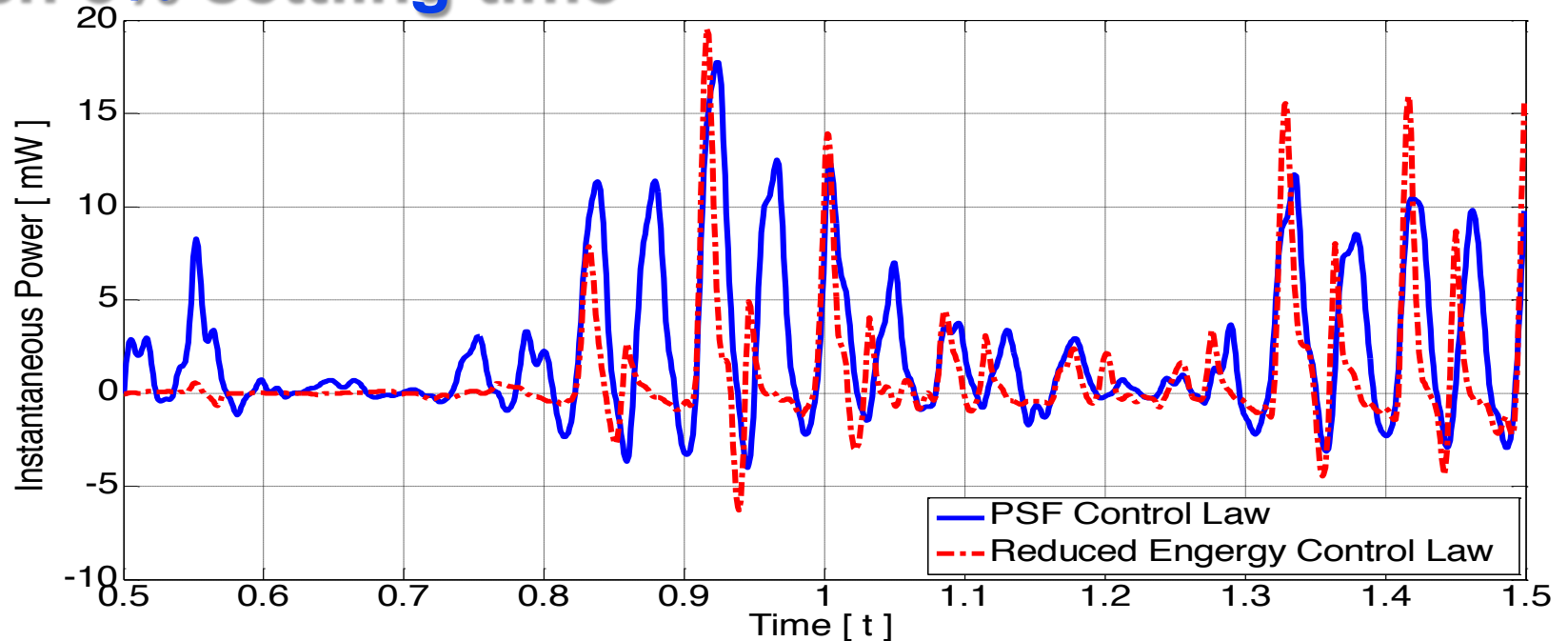

Element	PSF	REC	Ratio of Reduction
Voltage RMS (V)	100	82.3	18 %
Current RMS (mA)	0.065	0.053	18 %
Required Energy E_{tr} (mJ)	6.6	1.6	76 %
Average Power P_{st} (mW)	1.2	1.0	17 %

Experimental Validation on Multifunctional Composite Wing Spar

Experimental Setup for Autonomous Gust Alleviation

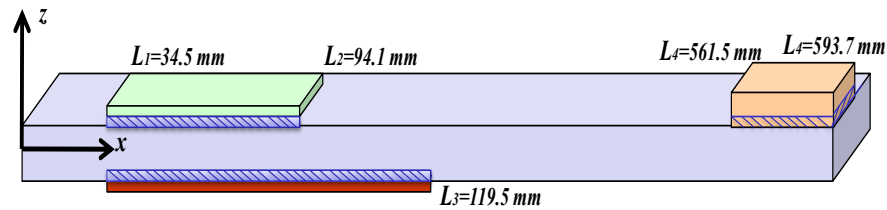

- A. QP16N (Harvester, Sensor)
- B. Honeycomb Core Fiberglass
- C. MFC(Actuator)
- D. Printable Circuit Board (PCB)
- E. Epoxy DP 460, Kapton

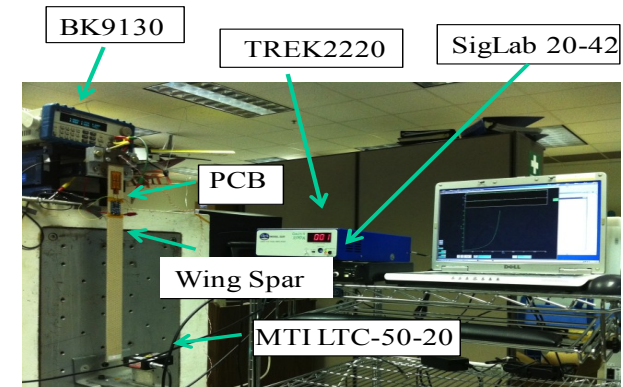

Property/Component	QP10n	MFC8528P1	Composite Substrate
Active Length	45mm	85mm	559.2mm
Active Width	20mm	28mm	38mm
Thickness	0.38mm	0.18mm	3.175
Mass	2.30gram	4.06gram	13.97gram
Young's Modulus	51GPa	42GPa	10.29GPa
Internal Capacitance	117nF	7.9nF	N/A
Piezoelectric Coefficient d_{33}	-190e-12	400e-9	N/A
Effective Distance from Clamp	38.4mm	30.5mm	N/A

Equivalent Circuit of a Reduced Energy Controller

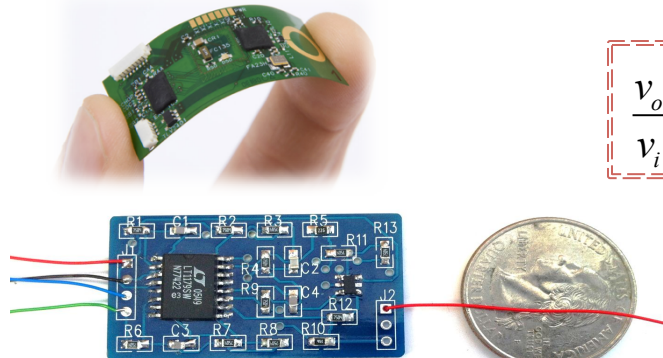

$$\frac{v_o}{v_i} = k \frac{\omega_f^2}{s^2 + 2\zeta_f \omega_f s + \omega_f^2}$$

1st order PSF control

$$k = \frac{R_2}{R_1} \left(1 + \frac{R_5}{R_4}\right), \omega_f = \frac{1}{C_1 C_2 R_2 R_3}, \zeta_f = \frac{C_1 (R_2 + R_3) \omega_f}{2}$$

Component Symbol	Nominal Values	Component Purpose
C1	150pF	C1_1 st Mode
C2	5600pF	C2_1 st Mode
C3	150pF	C1_2 nd Mode
C4	500pF	C2_2 nd Mode
R1	7.5MΩ	R1_1 st Mode
R2	7.5MΩ	R2_1 st Mode
R3	10MΩ	R3_1 st Mode
R4	7.5MΩ	R4_1 st Mode
R5	22.5MΩ	R5_1 st Mode
R6	7.5MΩ	R1_2 nd Mode
R7	7.5MΩ	R2_2 nd Mode
R8	7.5MΩ	R3_2 nd Mode
R9	7.5MΩ	R4_2 nd Mode
R10	15MΩ	R5_2 nd Mode
R11	7.5MΩ	Summing R1
R12	7.5MΩ	Summing R2
R13	7.5MΩ	Summing R3
J1		Inputs
J2		Outputs
U1		LT1179SW
U2		LT1782IS5

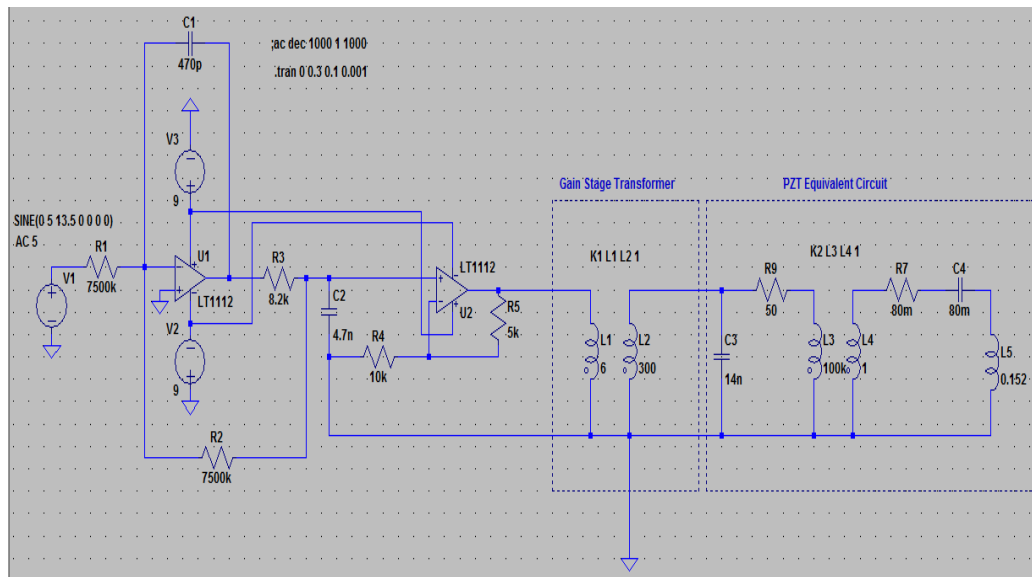

Experimental Characterization of Component Properties

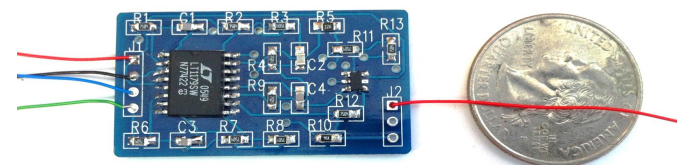
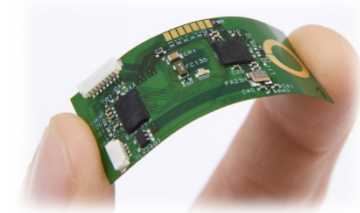
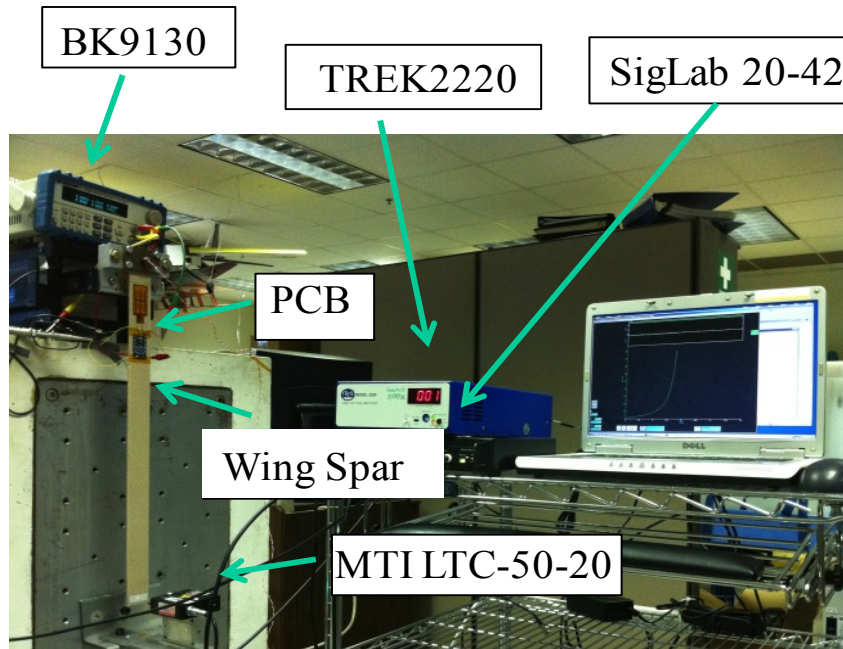

Property/Component	PCB
Length	40 mm
Width	10 mm
Thickness	1.016 mm
Distance from clamp to start of PCB	114 mm
Mass	2.625gram
Young's Modulus	30 GPa

Experimental Measurement of Gust Alleviation

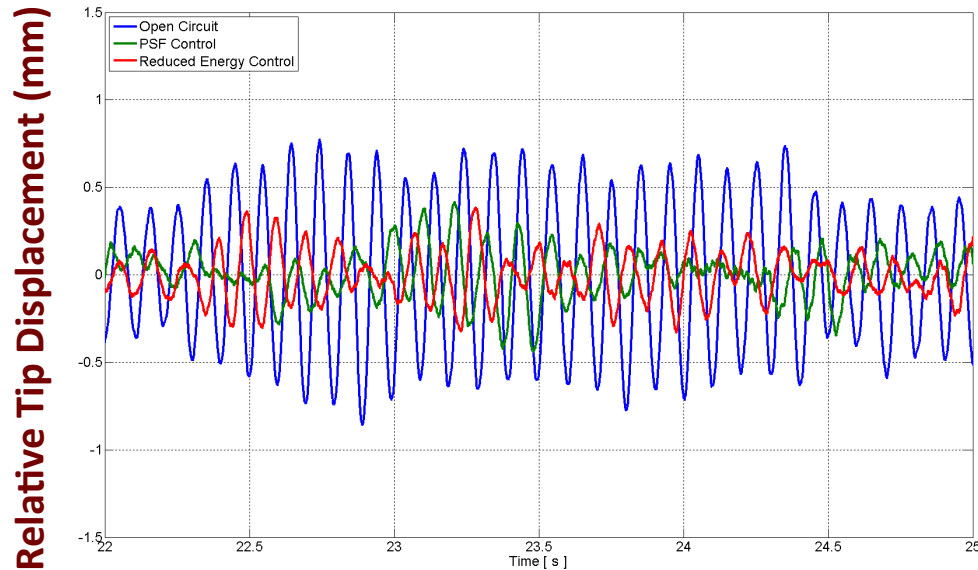

**0.45 mm (RMS)
to 0.09 mm (RMS)**

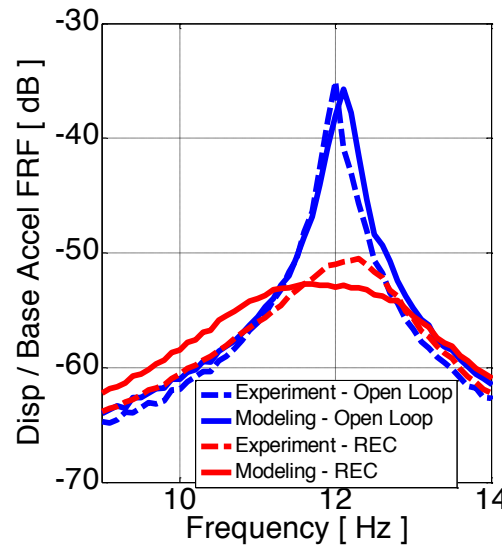
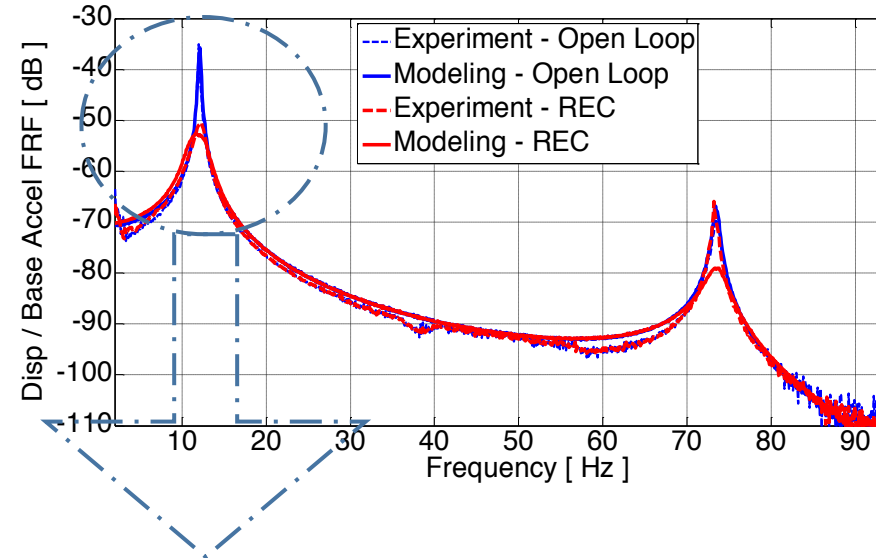

**14 dB reduction
@ 1st Mode
12 dB reduction
@ 2nd Mode**

Does it work?

- For any wind gust duration $t_g >$ settling time $t_s > 0.8s$, the total control energy satisfy:

$$E_{tot} = E_{tr} + P_{st} * (t_g - t_s).$$

- Then the total control energy required by PSF and REC becomes:

$$E_{tot}^{PSF} = 6.6 + 1.2 * (t_g - 0.8).$$

$$E_{tot}^{REC} = 1.6 + 1.0 * (t_g - 0.8).$$

- For average harvested power P^{harv} , the required harvesting time t_h to control a wind gust of duration t_g yields:

$$t_h = \frac{E_{tot}}{P^{harv}}.$$



Concluding Remarks



AEROSPACE ENGINEERING

UNIVERSITY of MICHIGAN ■ COLLEGE of ENGINEERING

Summary Comments

- 1) Established ambient vibration levels in time histories
- 2) Fabricated a multifunctional wing spar
- 3) Derived a predictive model for energy conversion from embedded PZT and MFC including associated electronics
- 4) Experimentally characterized reduced energy control law based on limited energy constraints
- 4) Experimentally validated simultaneous energy harvesting and vibration control



Acknowledgements

Supported by:

U.S. Air Force Office of Scientific Research

F9550-09-1-0625

Monitored by Dr. Les Lee



AEROSPACE ENGINEERING

UNIVERSITY of MICHIGAN ■ COLLEGE of ENGINEERING