

# Multifunctional (Nano)Composite Materials for Energy Storage: *Towards Flexible Load-Bearing Batteries and Supercapacitors*

---

K. Evanoff, S. Boukhalfa, J. Benson, B. Hertzberg, P. Dixon, A. Magasinsky, I. Kovalenko, **Gleb Yushin**

*Georgia Tech, Materials Science & Engineering, Atlanta, GA*  
*Email: [yushin@gatech.edu](mailto:yushin@gatech.edu)*

---

**THE 2<sup>ND</sup> “MULTIFUNCTIONAL MATERIALS FOR DEFENSE” WORKSHOP**  
Arlington, VA, July 30 - Aug 3, 2012

# Report Documentation Page

Form Approved  
OMB No. 0704-0188

Public reporting burden for the collection of information is estimated to average 1 hour per response, including the time for reviewing instructions, searching existing data sources, gathering and maintaining the data needed, and completing and reviewing the collection of information. Send comments regarding this burden estimate or any other aspect of this collection of information, including suggestions for reducing this burden, to Washington Headquarters Services, Directorate for Information Operations and Reports, 1215 Jefferson Davis Highway, Suite 1204, Arlington VA 22202-4302. Respondents should be aware that notwithstanding any other provision of law, no person shall be subject to a penalty for failing to comply with a collection of information if it does not display a currently valid OMB control number.

1. REPORT DATE <b>AUG 2012</b>		2. REPORT TYPE		3. DATES COVERED <b>00-00-2012 to 00-00-2012</b>	
4. TITLE AND SUBTITLE <b>Multifunctional (Nano)Composite Materials for Energy Storage: Towards Flexible Load-Bearing Batteries and Supercapacitors</b>				5a. CONTRACT NUMBER	
				5b. GRANT NUMBER	
				5c. PROGRAM ELEMENT NUMBER	
6. AUTHOR(S)				5d. PROJECT NUMBER	
				5e. TASK NUMBER	
				5f. WORK UNIT NUMBER	
7. PERFORMING ORGANIZATION NAME(S) AND ADDRESS(ES) <b>Georgia Tech, Materials Science &amp; Engineering, Atlanta, GA, 30332</b>				8. PERFORMING ORGANIZATION REPORT NUMBER	
9. SPONSORING/MONITORING AGENCY NAME(S) AND ADDRESS(ES)				10. SPONSOR/MONITOR'S ACRONYM(S)	
				11. SPONSOR/MONITOR'S REPORT NUMBER(S)	
12. DISTRIBUTION/AVAILABILITY STATEMENT <b>Approved for public release; distribution unlimited</b>					
13. SUPPLEMENTARY NOTES <b>Presented at the 2nd Multifunctional Materials for Defense Workshop in conjunction with the 2012 Annual Grantees'/Contractors' Meeting for AFOSR Program on Mechanics of Multifunctional Materials &amp; Microsystems Held 30 July - 3 August 2012 in Arlington, VA. Sponsored by AFRL, AFOSR, ARO, NRL, ONR, and ARL. U.S. Government or Federal Rights License</b>					
14. ABSTRACT					
15. SUBJECT TERMS					
16. SECURITY CLASSIFICATION OF:			17. LIMITATION OF ABSTRACT	18. NUMBER OF PAGES	19a. NAME OF RESPONSIBLE PERSON
a. REPORT <b>unclassified</b>	b. ABSTRACT <b>unclassified</b>	c. THIS PAGE <b>unclassified</b>			

## Why Nanocomposite Electrodes?

- Ability to store energy of Li-ion batteries and supercapacitors is largely governed by the ability of their electrode materials to host high content of ions
  - Many active materials exhibit outstanding ability for ion storage but suffer from some limitations (e.g. large volume changes during insertion/extraction of ions and/or low electrical and ionic conductivity)
  - Rational design of carbon-containing nanocomposite electrodes allows one to overcome these limitations while still achieving up to 90 % of the theoretical energy storage
- 
- In addition, the use of MULTI-FUNCTIONAL electrodes (e.g., with added load-bearing functionalities) has the potential to greatly reduce the overall weight of the system

# Supercapacitors and Li-ion Batteries

- ✓ **Need More Energy per unit mass (and volume!) of the system**
- ✓ **Need More Power per unit mass (and volume!) of the system**

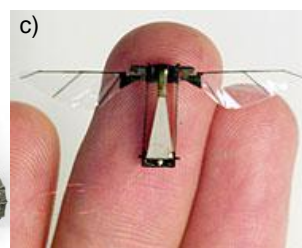
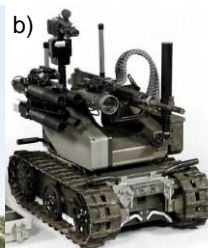
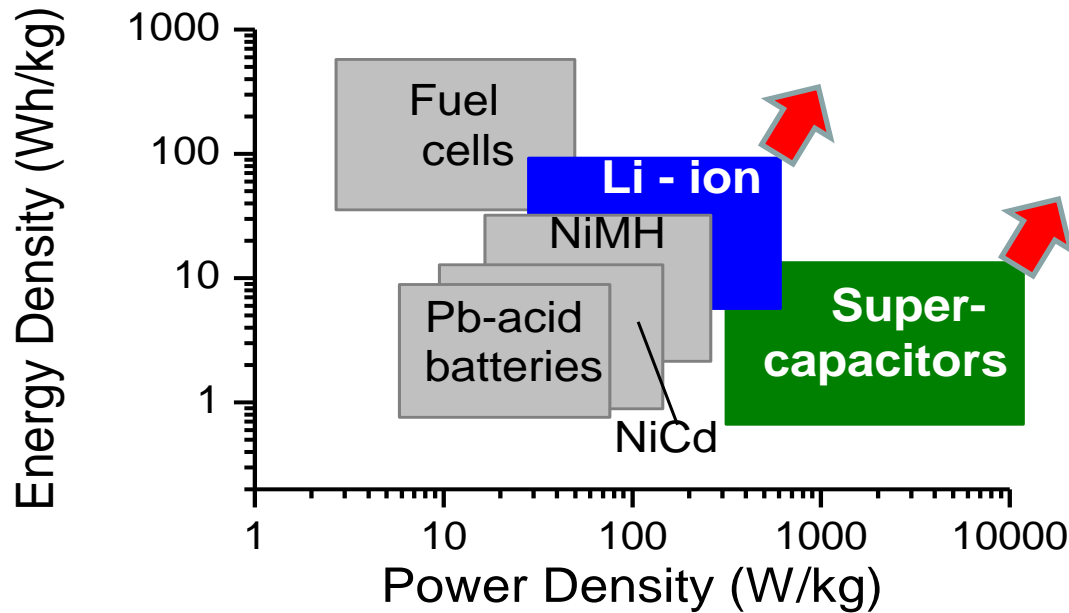

# Operating Principle of Li-ion battery

- “Rocking-chair” or “shuttlelock” mechanism: **Li ions shuttle between the anode and the cathode**
- Higher capacity of the cathode or the anode will lead to higher capacity of a battery
- The potential between the anode and the cathode determines the open circuit voltage of a Li-ion battery

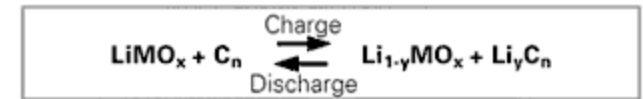

Chemical Reaction

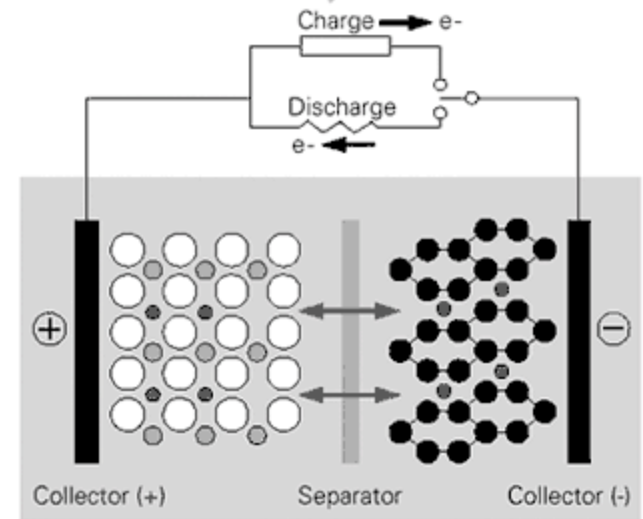

- O
- Li
- M (Co, Mn, Ni)
- C (Graphite, Coke)

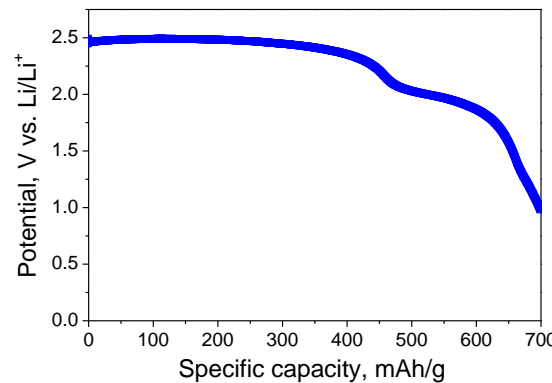
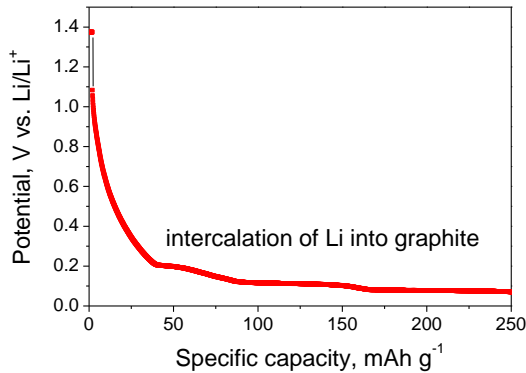

# Multifunctional Nano-Composite Fabric

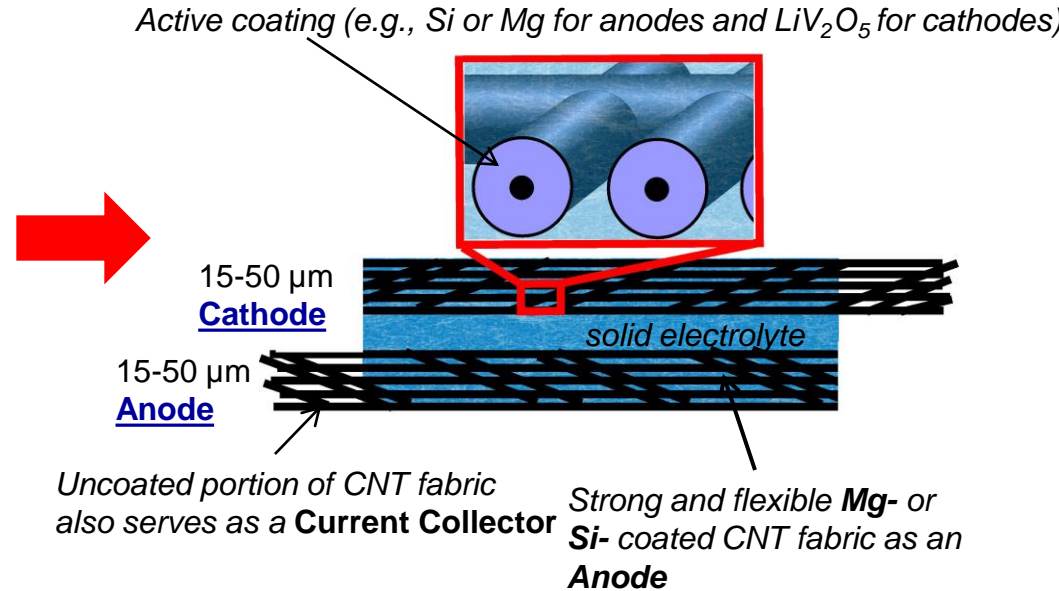
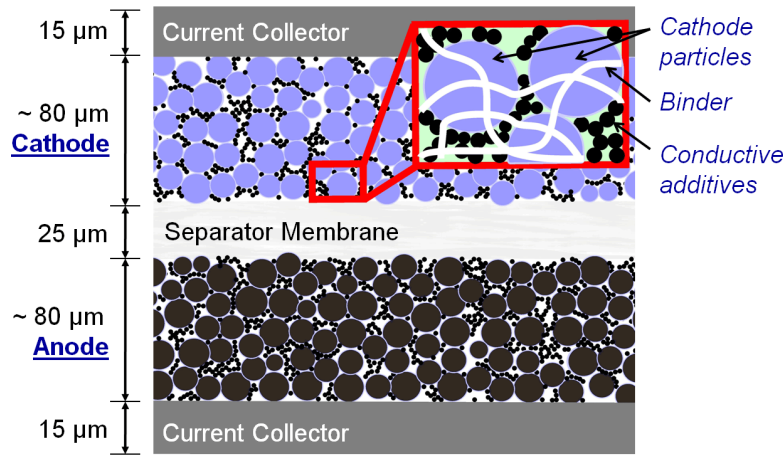

## Traditional Electrodes and Cell Architecture

- Low electrical conductivity
- Low thermal conductivity
- Heavy/bulky metal foils
- No mechanical strength

## Multifunctional Nano-Composite Fabric

- Ultra-High electrical conductivity
- High thermal conductivity
- No metal foil current collectors needed
- Enhanced safety (*when solid electrolyte is used*)
- High mechanical strength / multifunctionality

## Limitations of Graphitic Anodes

- Limited specific capacity: theoretical capacity of 374 mAh/g corresponds to **1 Li per 6 C atoms ( $\text{LiC}_6$ )**
- Most commercial graphitic anodes experience capacity of  $\sim 270\text{-}340$  mAh/g
- Binder (3-8 wt. %) and current collector (Cu) add weight and thus lower the effective specific capacity to  $\sim 200$  mAh/g, particularly for high power cells
- If graphite is replaced with Carbon fibers or CNTs, the mechanical properties of the CNT will be significantly reduced after cycling because insertion and extraction of Li between the graphene layers. Thus, multifunctionality will not be feasible with pure C anodes

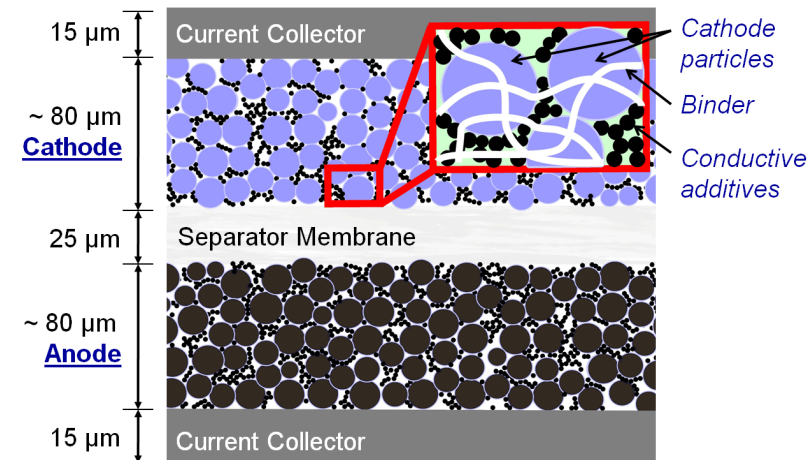
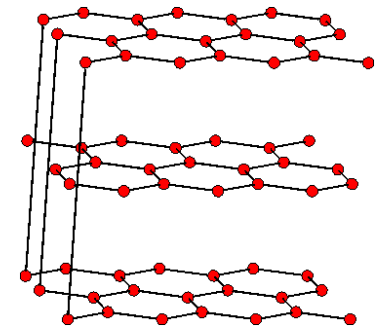

# High Capacity Anodes for Li-ion Batteries

- Metals or semiconductors that alloy with Li offer much higher theoretical capacity than graphite
- Si capacity is ~ 4000 mAh/g
- **Challenges:**
  - Unless strongly lithiated, Si exhibits **low electrical** and **low ionic conductivity**
  - Large Si particles pulverize and cannot be discharged sufficiently rapidly
  - Small Si nanoparticles exhibit very **large thermal and electrical resistance** as well as very **large specific surface area and therefore large irreversible capacity losses** (low Columbic Efficiency)
  - Si expansion leads to **changes in the electrode thickness** and reduces SEI stability

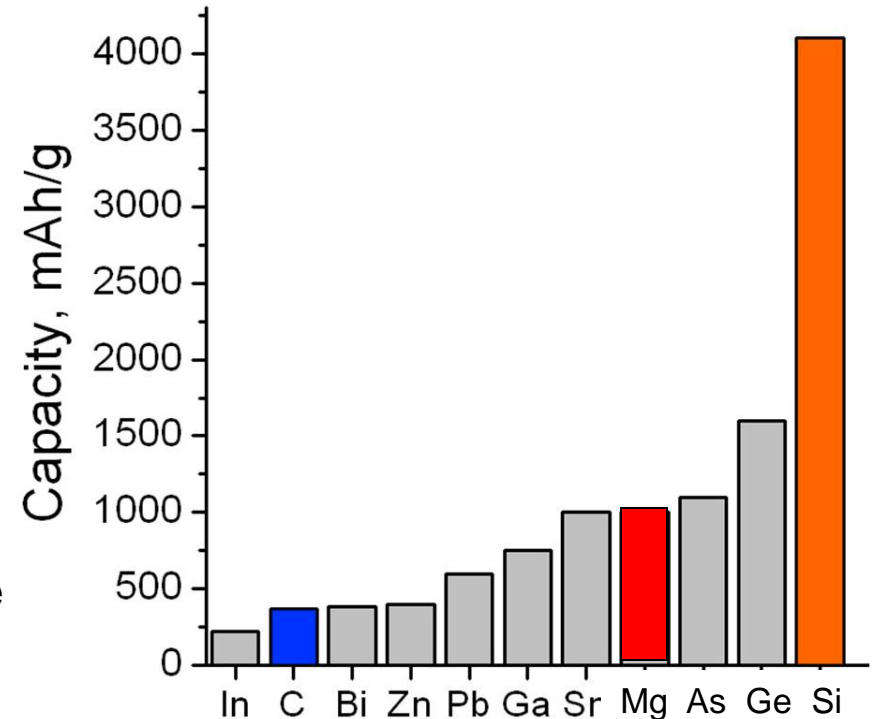

# Si-C Nanocomposites Can do Better Job Than Si

Annealed carbon black (CB)



Si nanoparticles' assembly on the surface of annealed CB

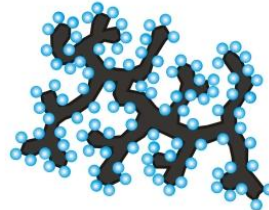

Assembly of Si-coated CB particles into rigid spherical granules

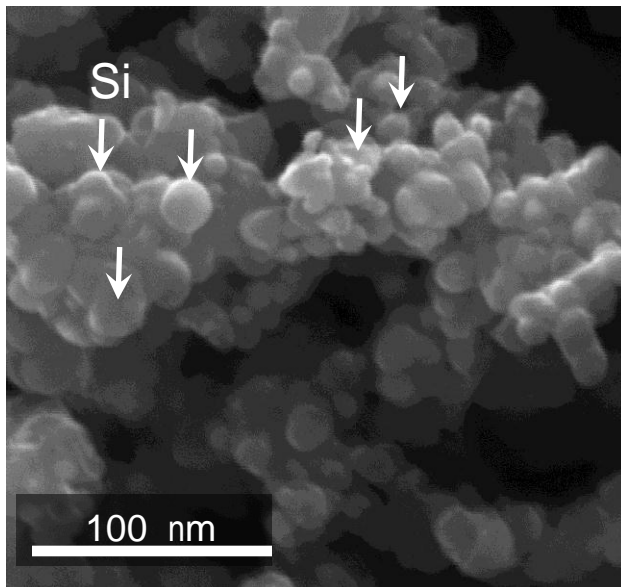
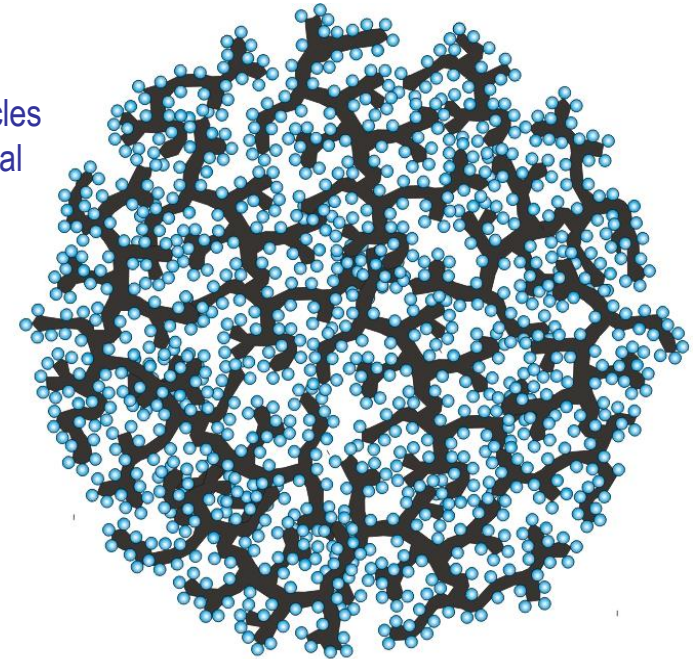

- 👍 • Uniformity of the deposited Si nanoparticles
- 👍 • No volume changes during Li insertion/extraction
- 👍 • Compatibility with existing manufacturing technologies (drop-in replacement)
- 👍 • High electrical & thermal conductivity

# Si-C Nanocomposites Can do Better Job Than Si

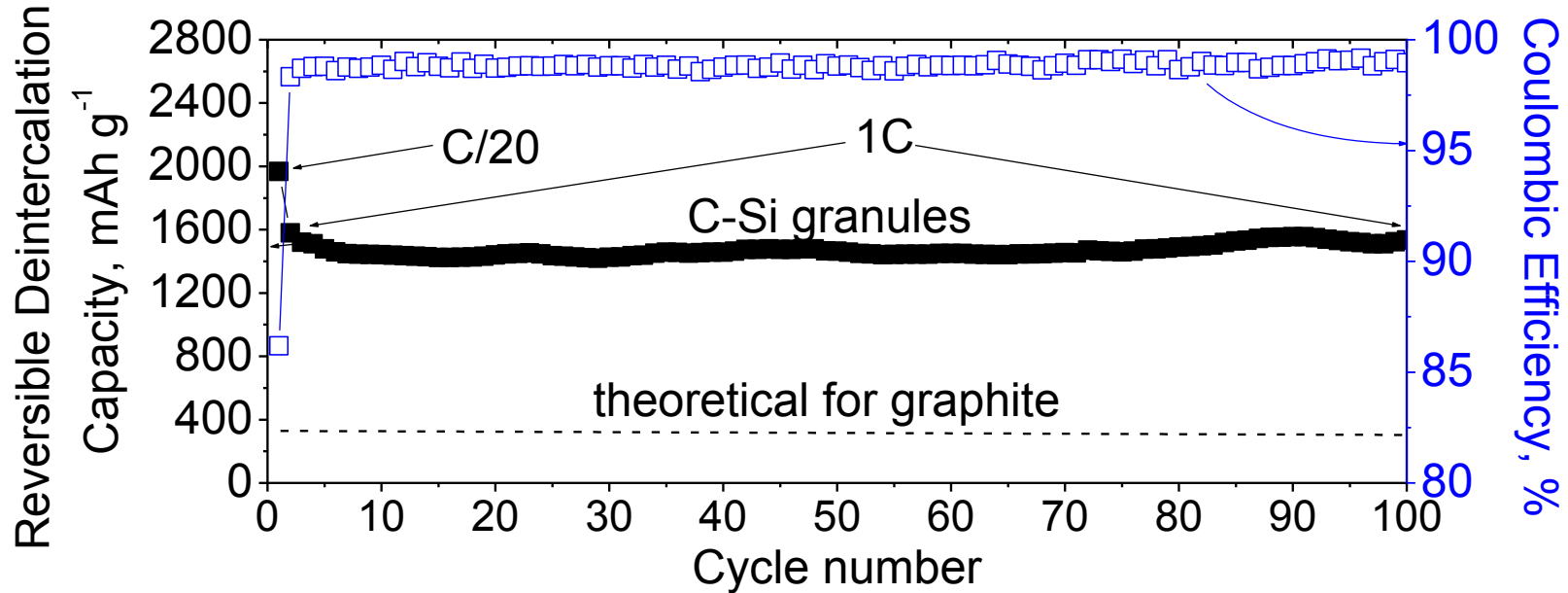

Before cycling

After

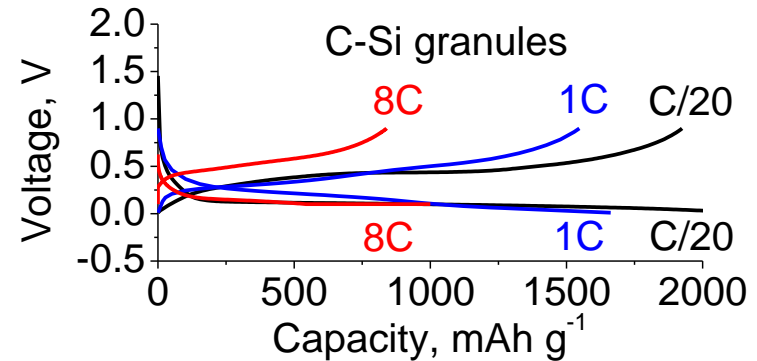
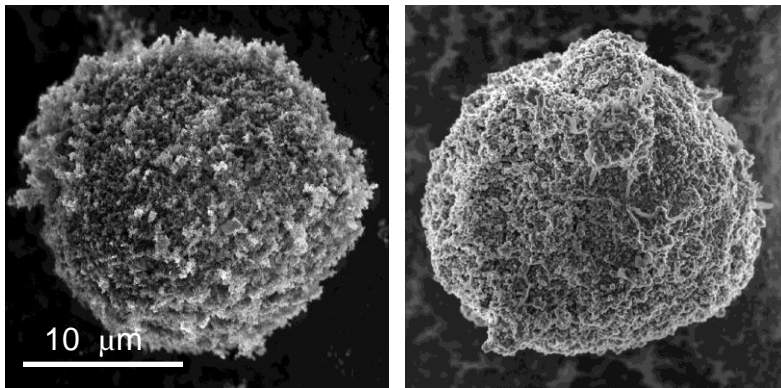

# Si-C Nanocomposites Can do Better Job Than Si

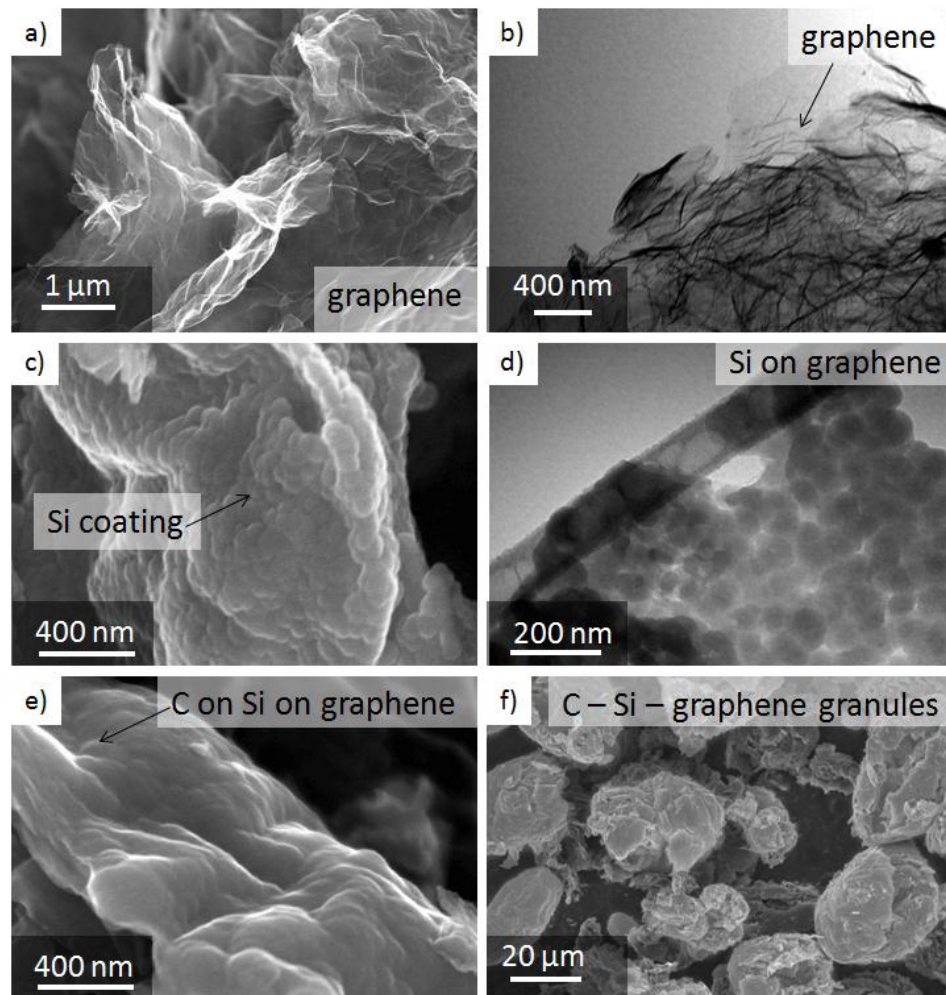
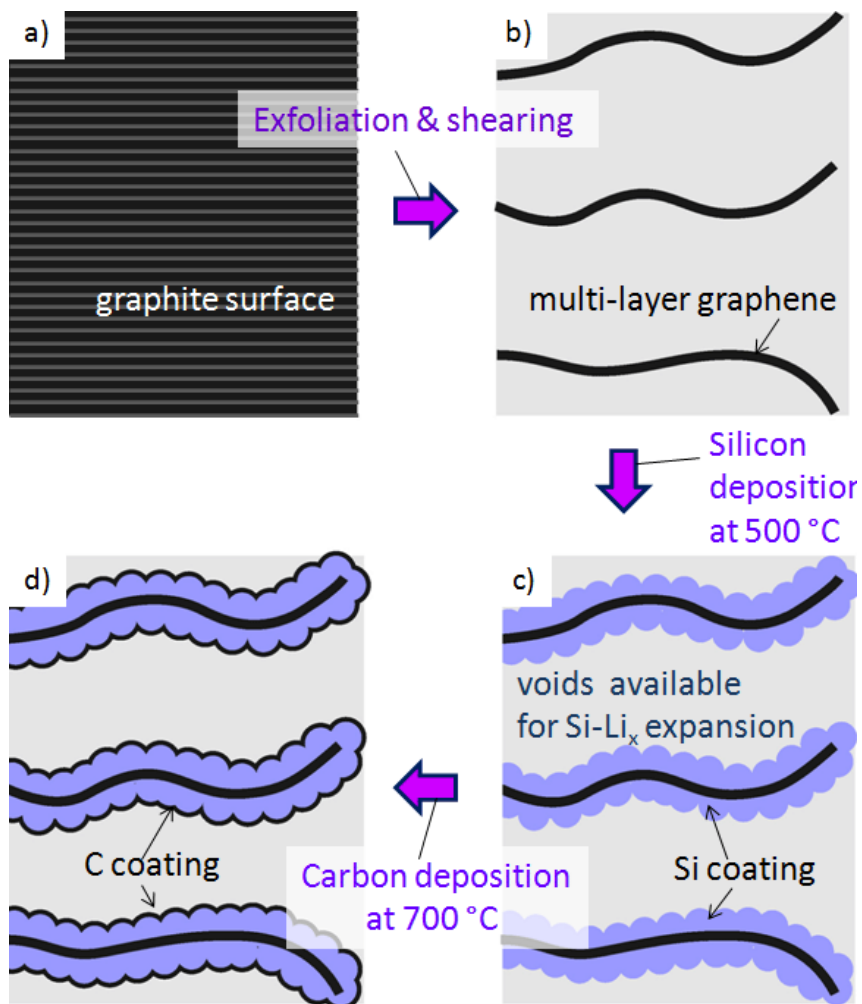

Patent pending

# Functional Polymer Coatings on Active Particles (e.g. on Si) May Improve Electrode Performance

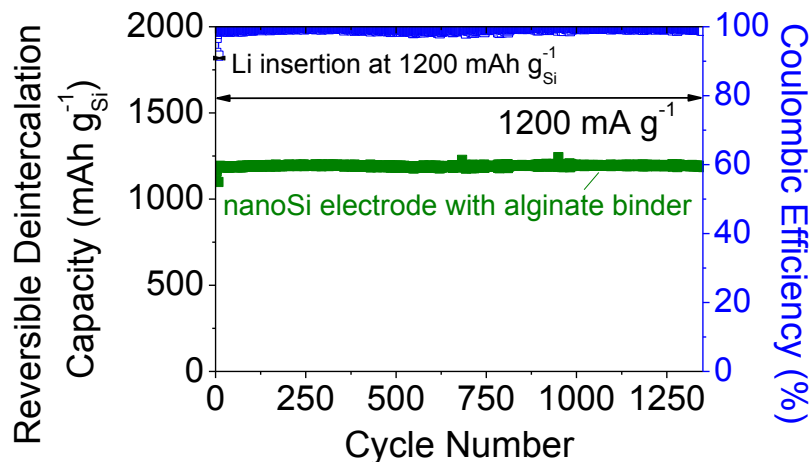
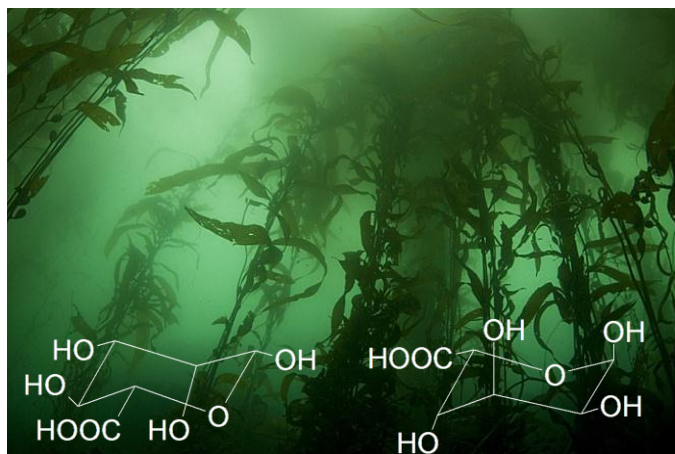

*Patent pending*

- Alginate is extracted from brown algae, which is: the fastest growing plant on the planet, does not need agricultural land
- Environmentally-friendly process: (a) growing algae captures CO<sub>2</sub> and produced O<sub>2</sub>; (b) alginate (as a Na-alginate) is produced from brown algae by boiling it in a soda solution (no need for extensive chemical treatment; in contrast, CMC synthesis involves the alkali-catalyzed reaction of cellulose with chloroacetic acid to introduce carboxy groups); (c) solvent – water (in contrast, PVDF requires NMP)

# CNT fabric for Nano-Composite Anode

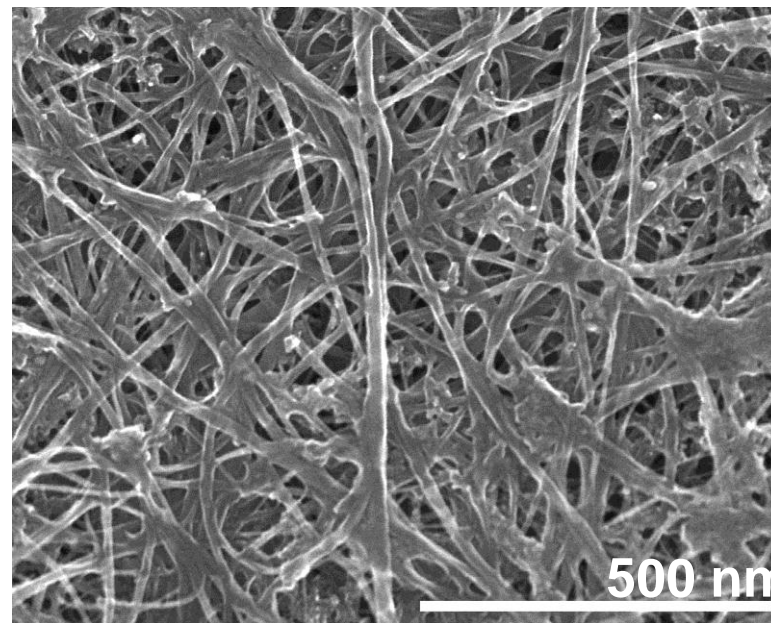

CNT supplied by:



# Si-C Nano-Composite Anode Fabric

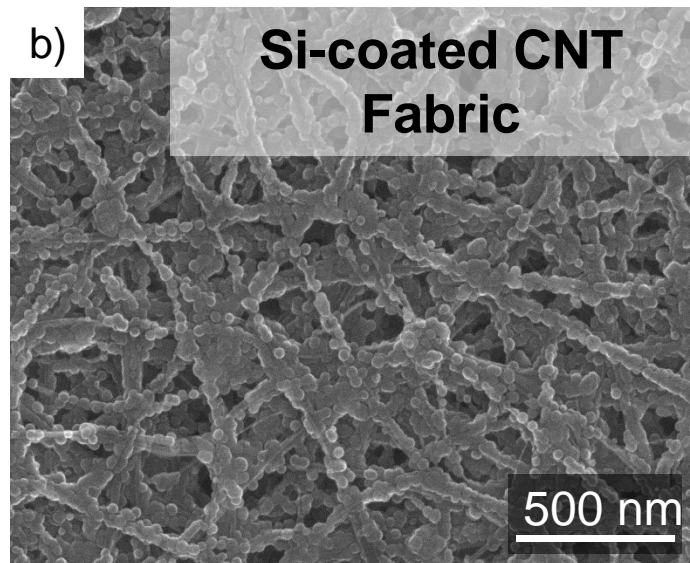
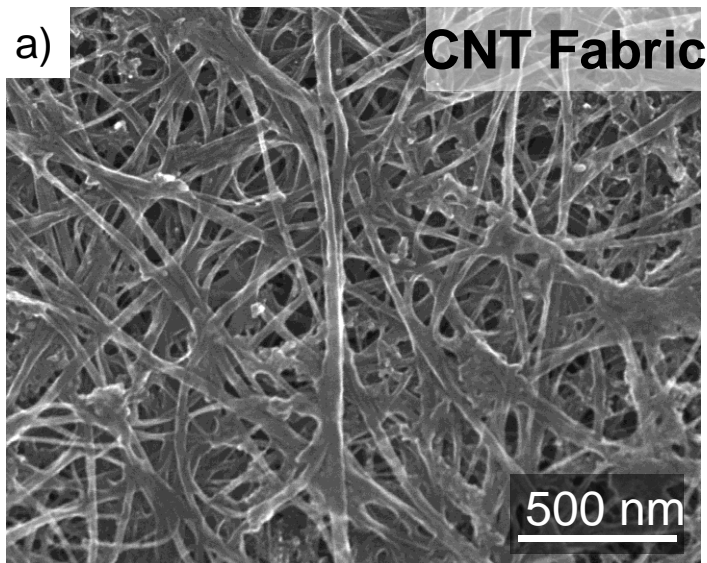

# Si-C Nano-Composite Anode Fabric

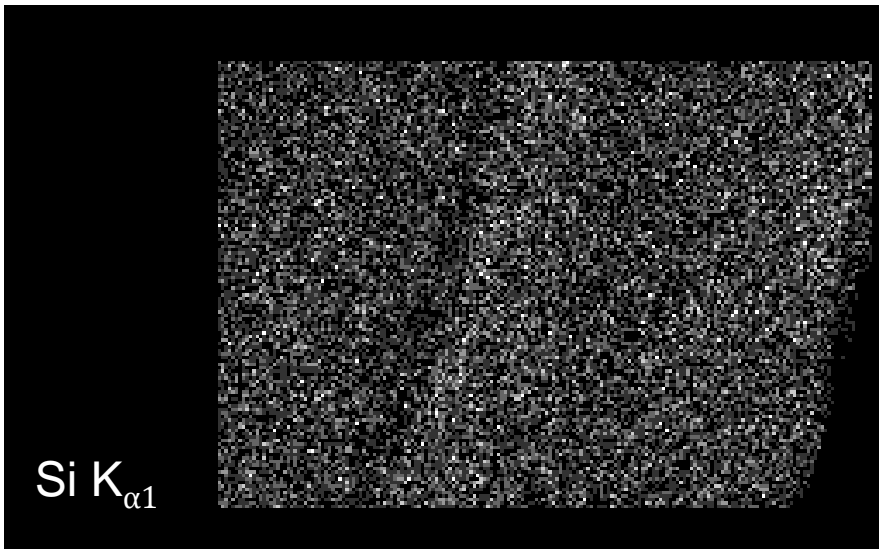
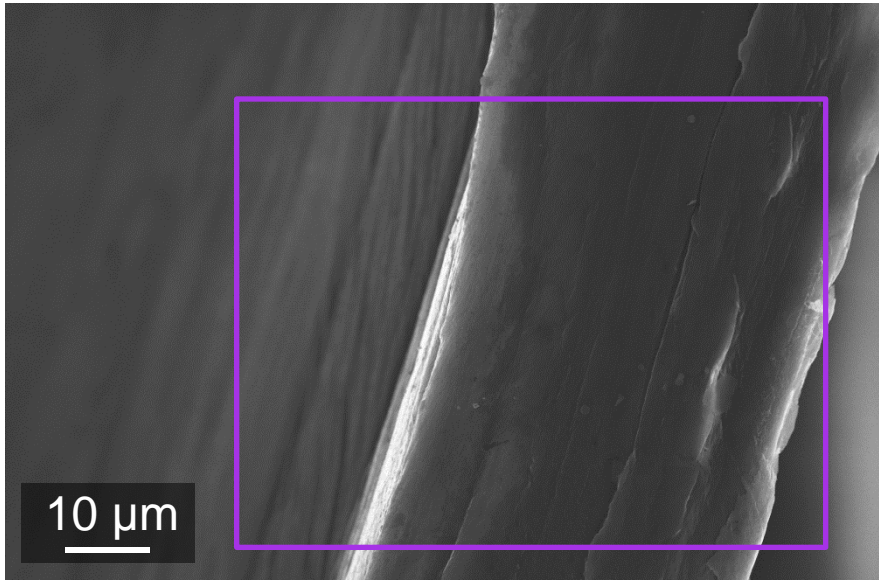

- Uniform Si deposition within the CNT-based electrode

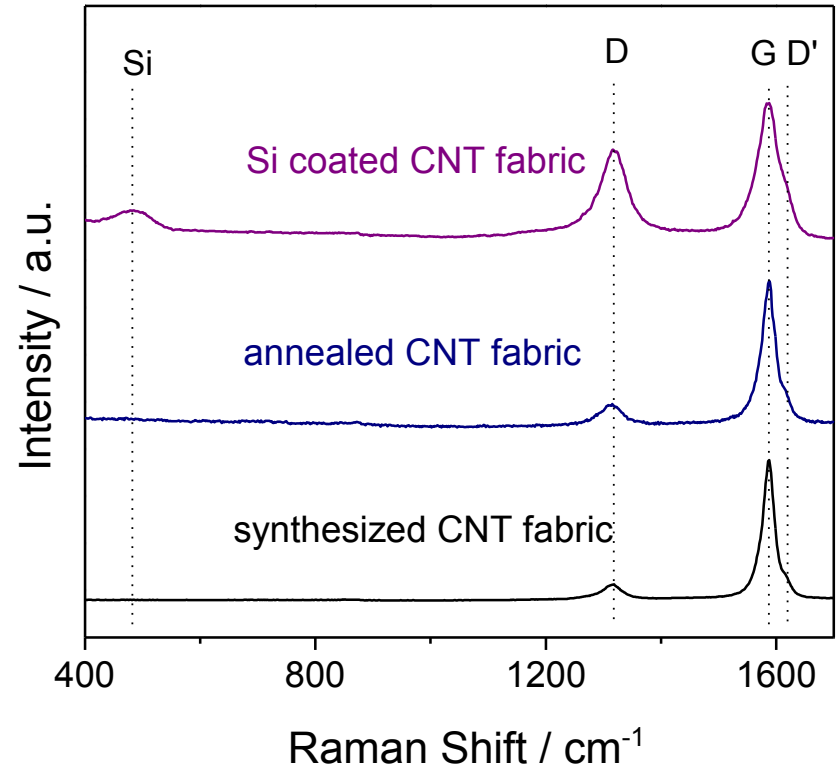

# Si-C Nano-Composite Anode Fabric

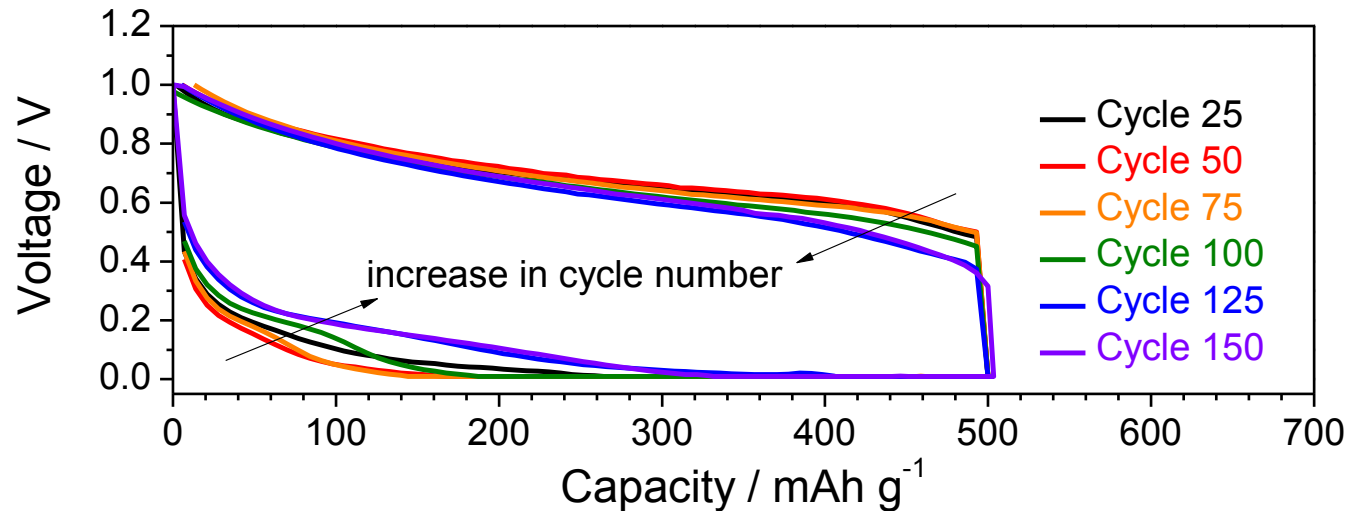
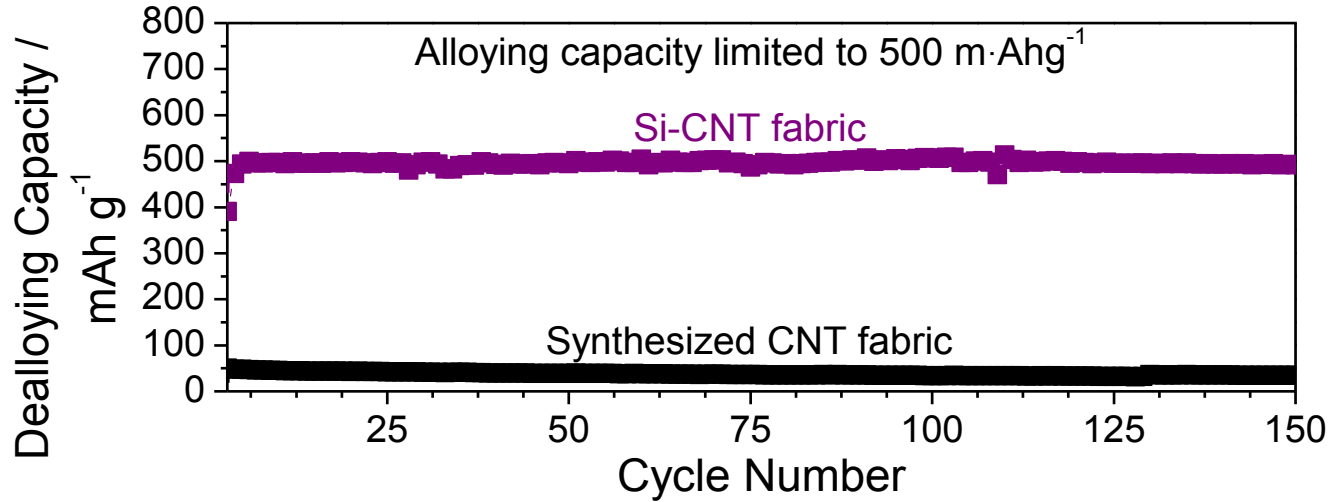

# Si-C Nano-Composite Anode Fabric

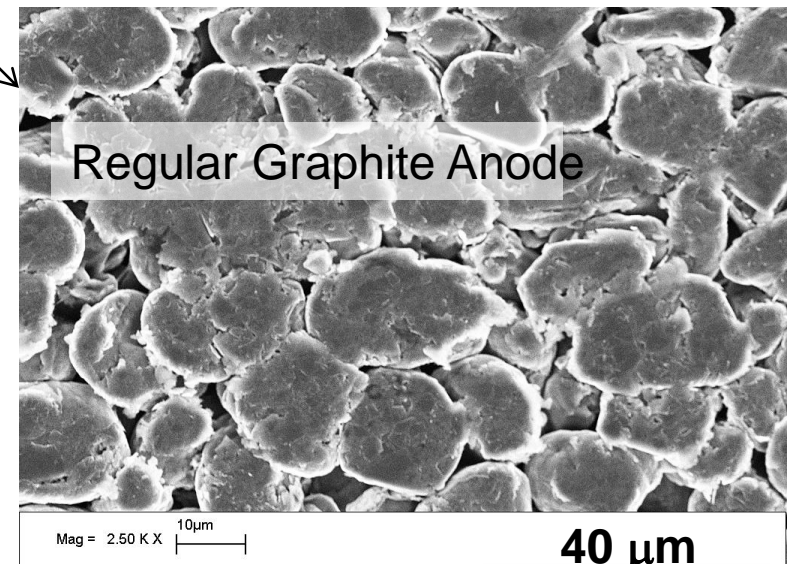
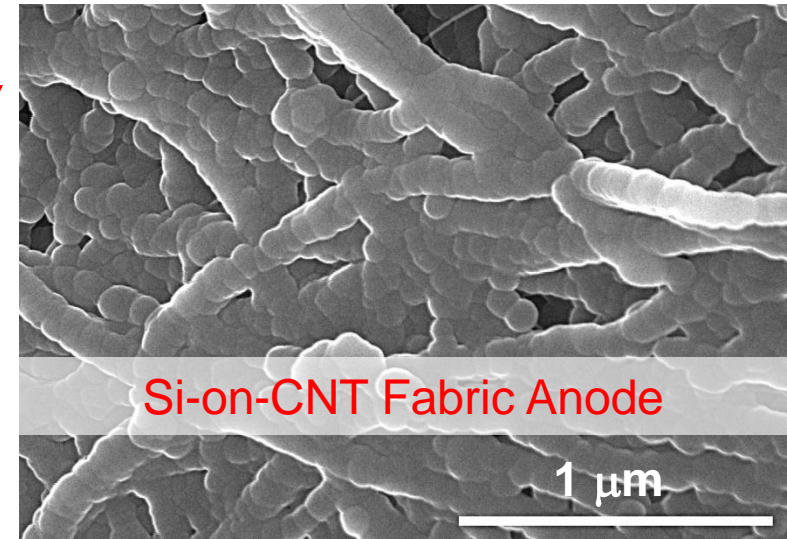
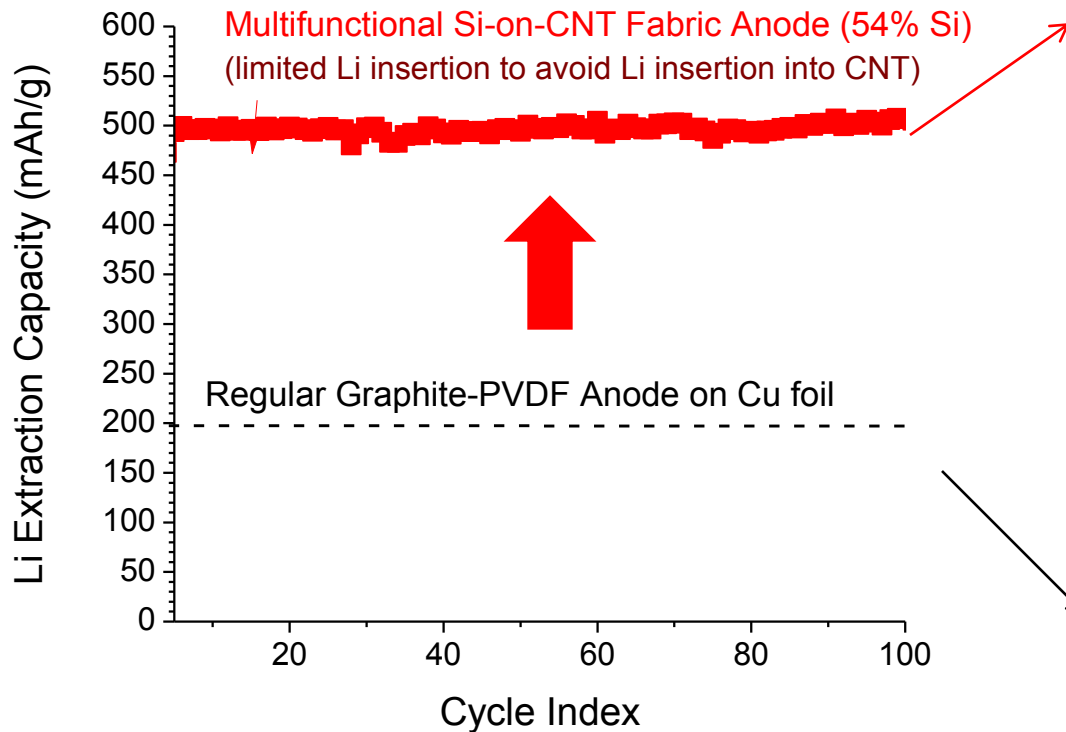

**Note:**

Density of 90 μm Graphite coating < 1.6 g/cc  
(each side) ; Density of 18 μm Cu = 9 g/cc

# CNT Fabric: Effect of Annealing (since we deposit Si at 500 C)

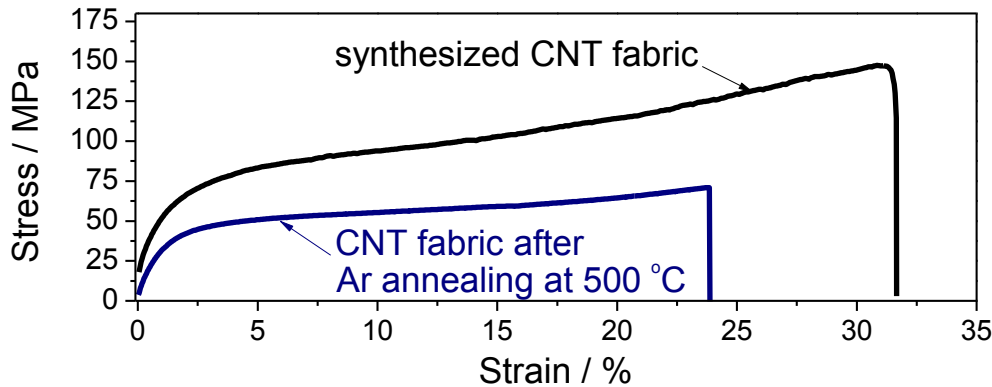

- Moderate reduction in strain and strength upon annealing in Ar at 500 C for 1h

- Likely due to reduction of the CNT-CNT bonding strengths caused by stripping some of the functional groups

## XPS survey scan

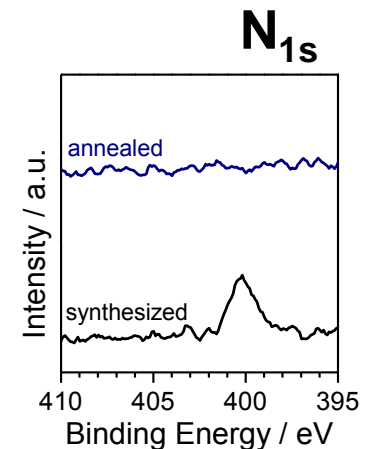
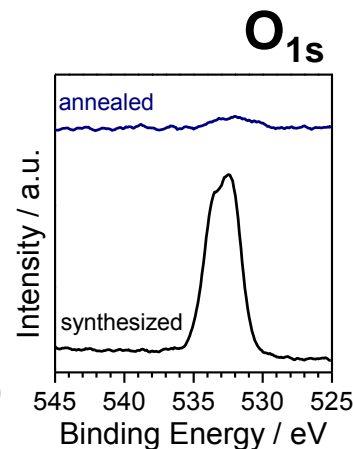
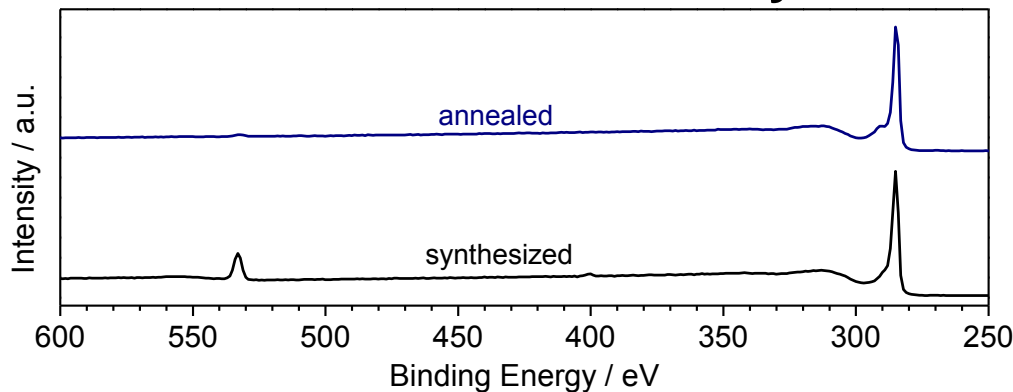

# Si-C Nano-Composite Anode Fabric

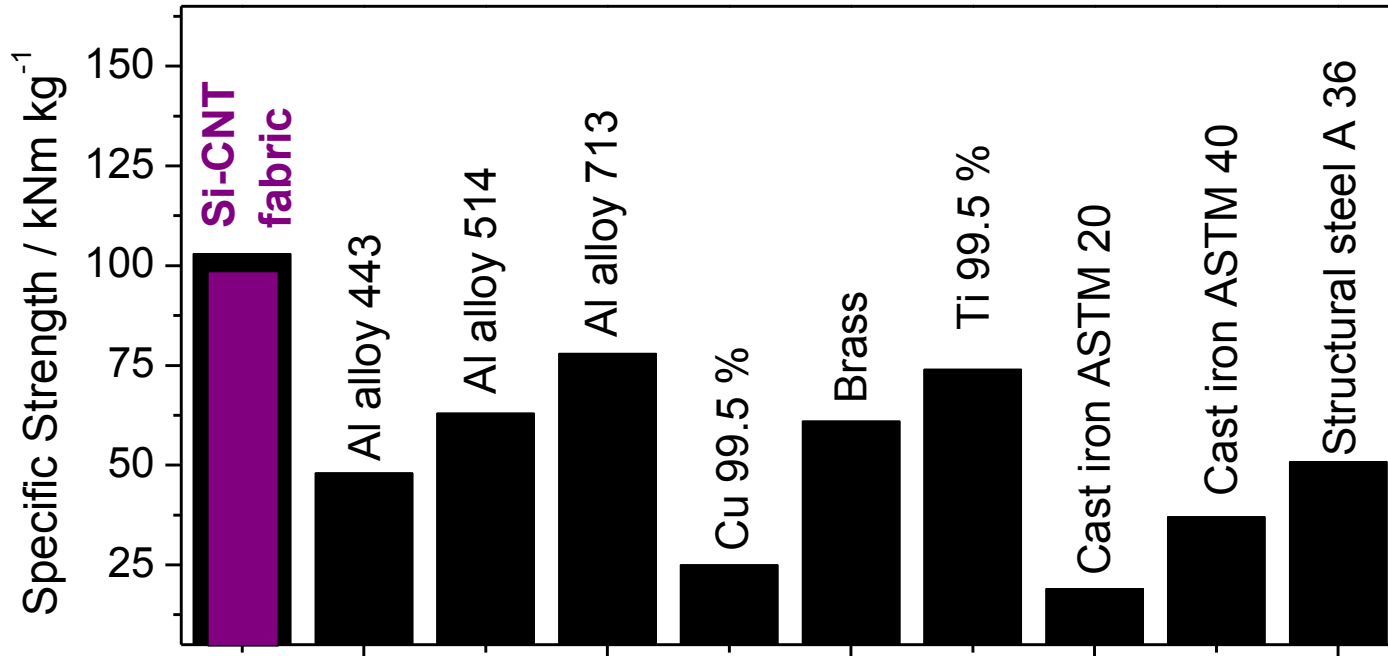
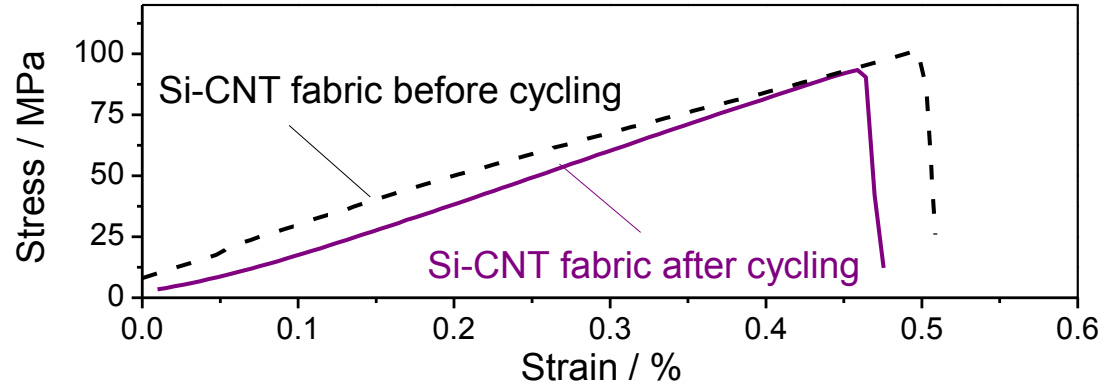

# Si-C Nano-Composite Anode Fabric

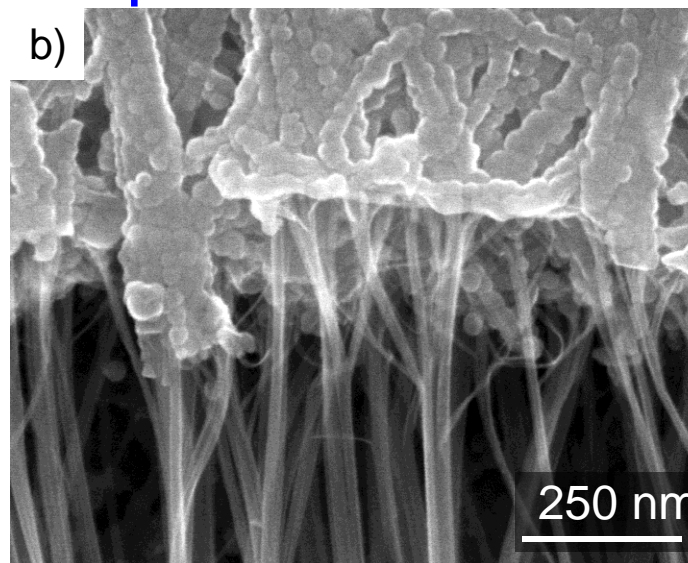
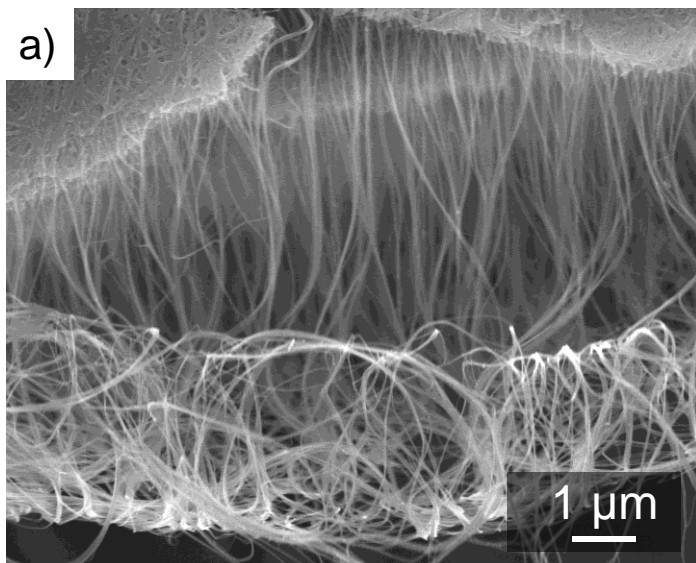

- Pull-out Behavior

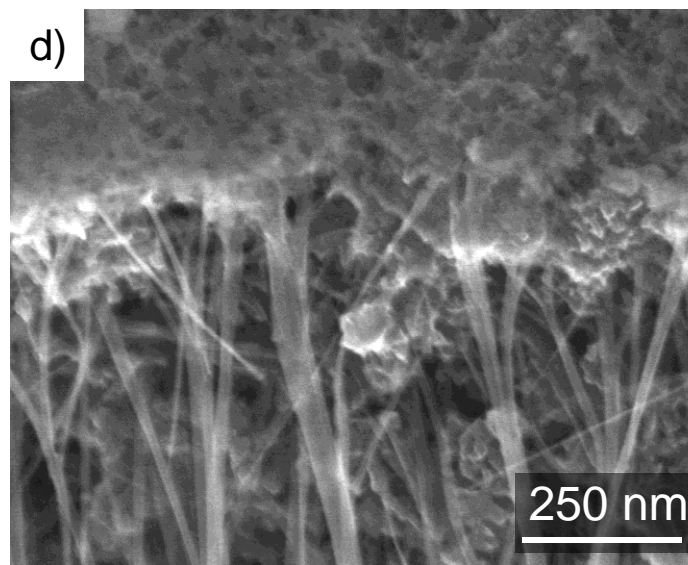
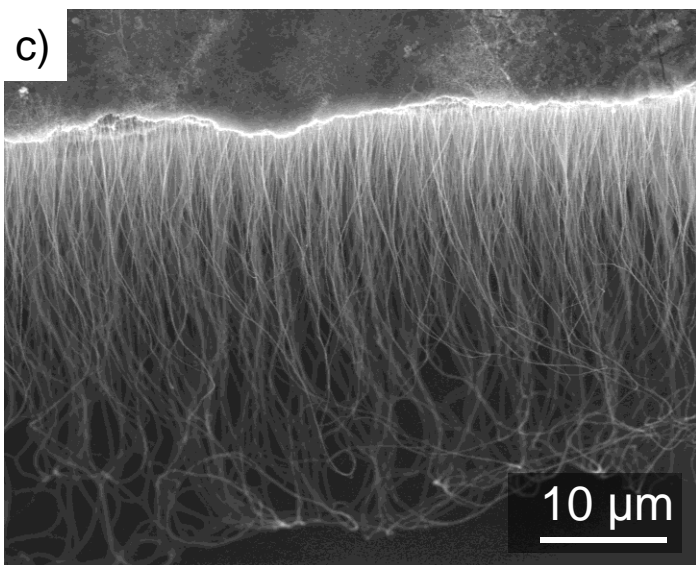

## Si-C Nano-Composite Anode Fabric

	$\rho$ $1 \times 10^{-3} \text{ W}\cdot\text{cm}$	<b>K</b> $\text{W}\cdot\text{m}^{-1}\text{K}^{-1}$
CNT fabric	$1.17 \pm 0.11$	$29.72 \pm 3.24$
Si-coated CNT fabric	$2.93 \pm 0.34$	$17.59 \pm 1.95$
Si nanopowder electrode	$327,500 \pm 22,000$	0.40
Graphite electrode		1.04

- High Thermal and Electrical Conductivities
- Still likely limited by the Electrode-Probe Contact Resistance

# Vertically Aligned CNT - Based Electrodes

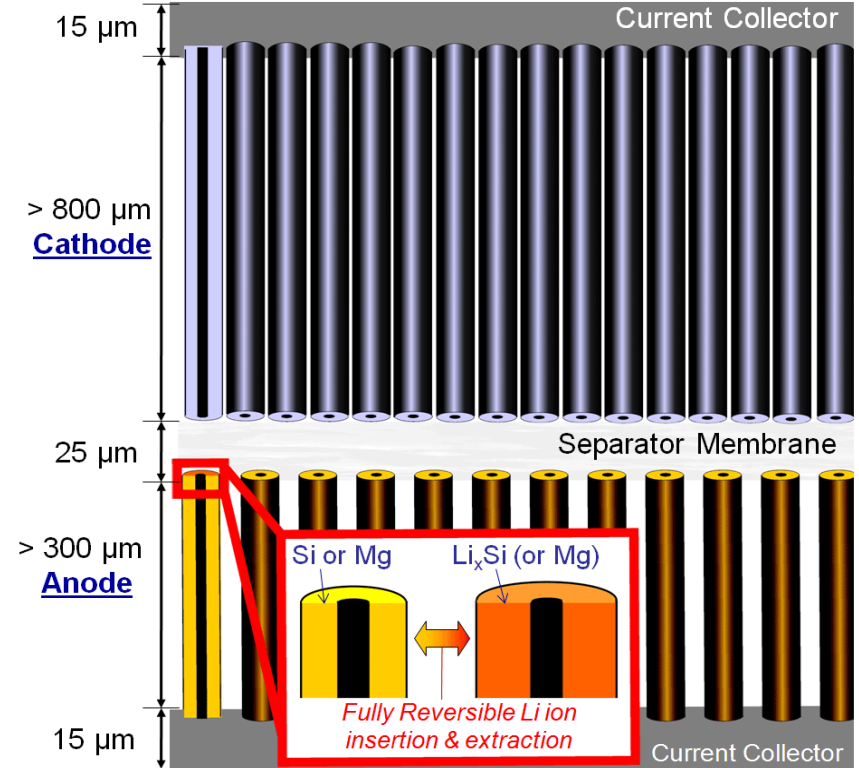
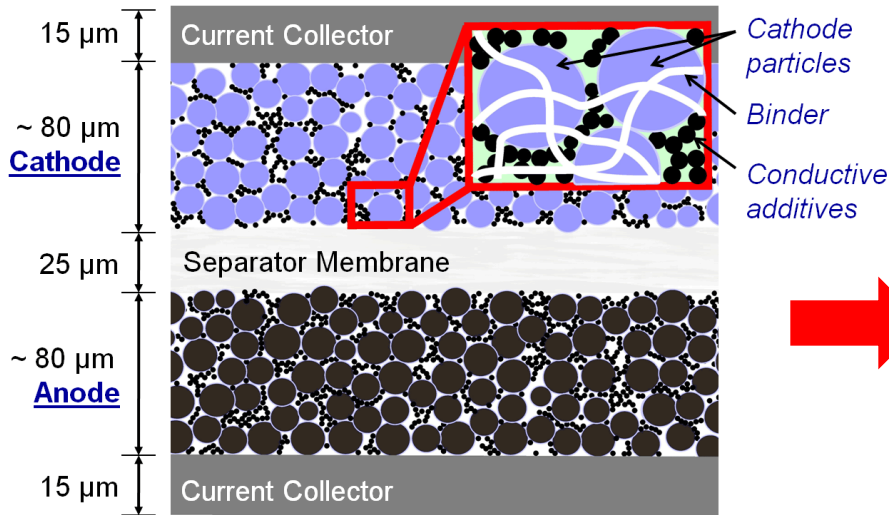

## Traditional Electrodes and Cell Architecture

- Low electrical conductivity
- Low thermal conductivity
- Heavy/bulky metal foils

- Ultra-High electrical conductivity
- High thermal conductivity
- Thicker electrodes and thus smaller contribution of inactive components (separators, metal foils, etc.)

## Multi-Walled CNT Growth

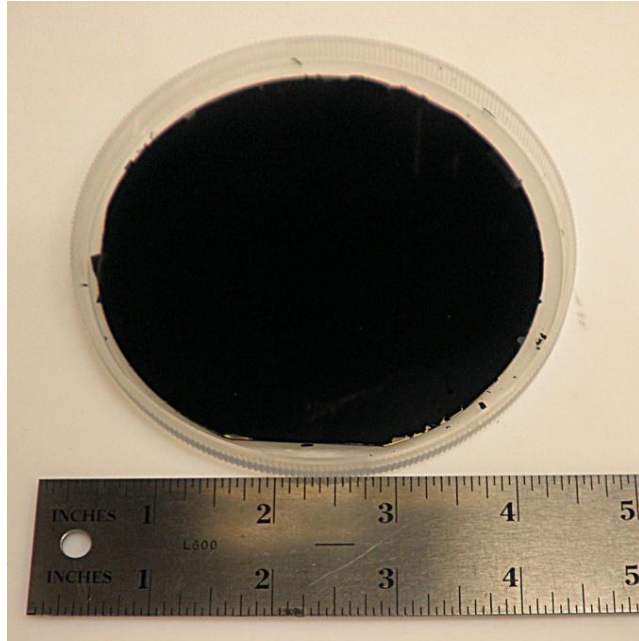

- Tube diameter: 30 nm
- Growth on wafers of up to 4 " possible
- Tube length synthesized: 0.2-2 mm
- Growth time: **2-10 min** for tubes up to 2 mm long
- Can be transferred to Cu foil (or any other) current collectors

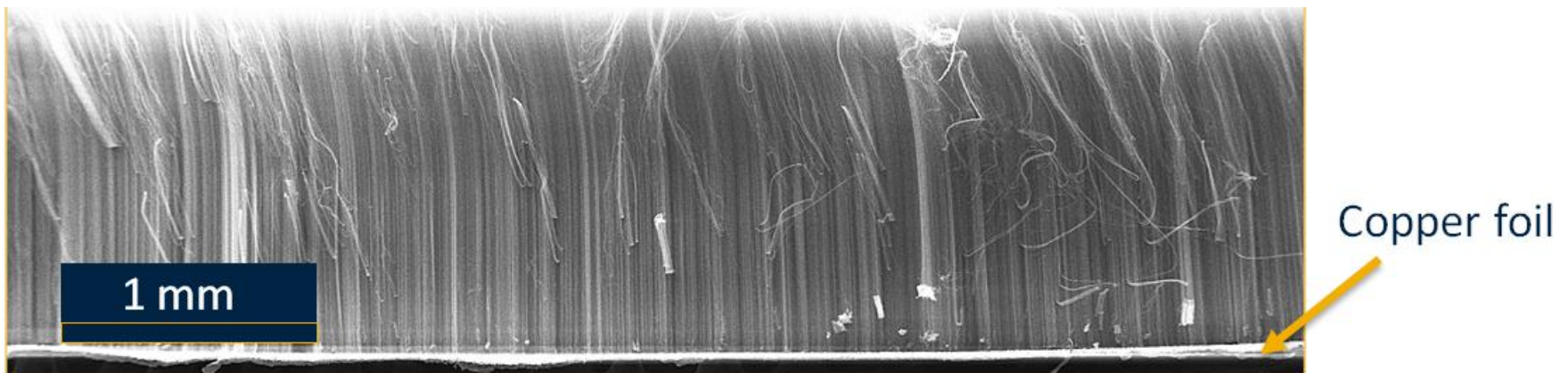

# Si-coated Vertically Aligned CNT Anodes

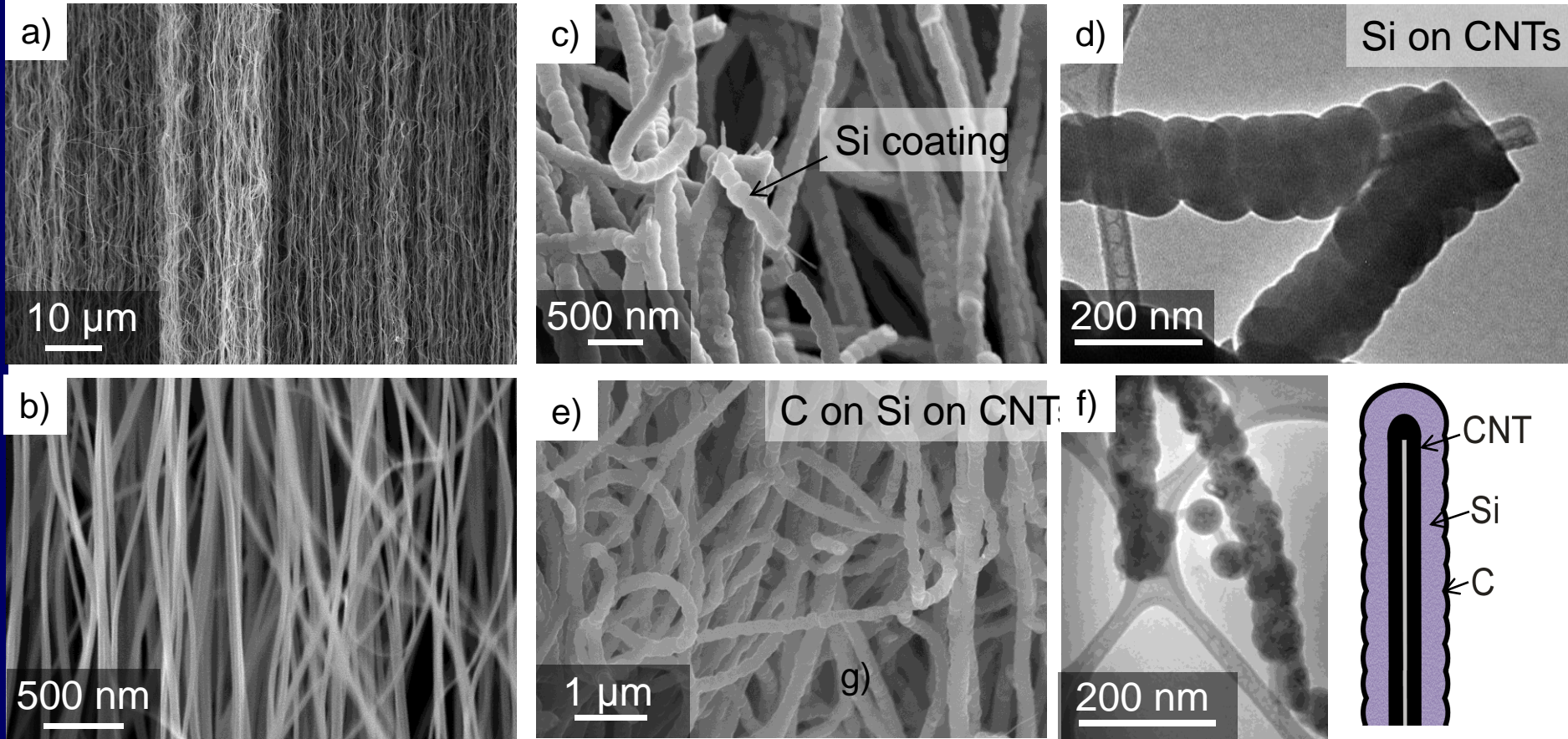

Si coating deposition via CVD ( $\text{SiH}_4$  decomposition)

## Si-coated Vertically Aligned CNT Anodes

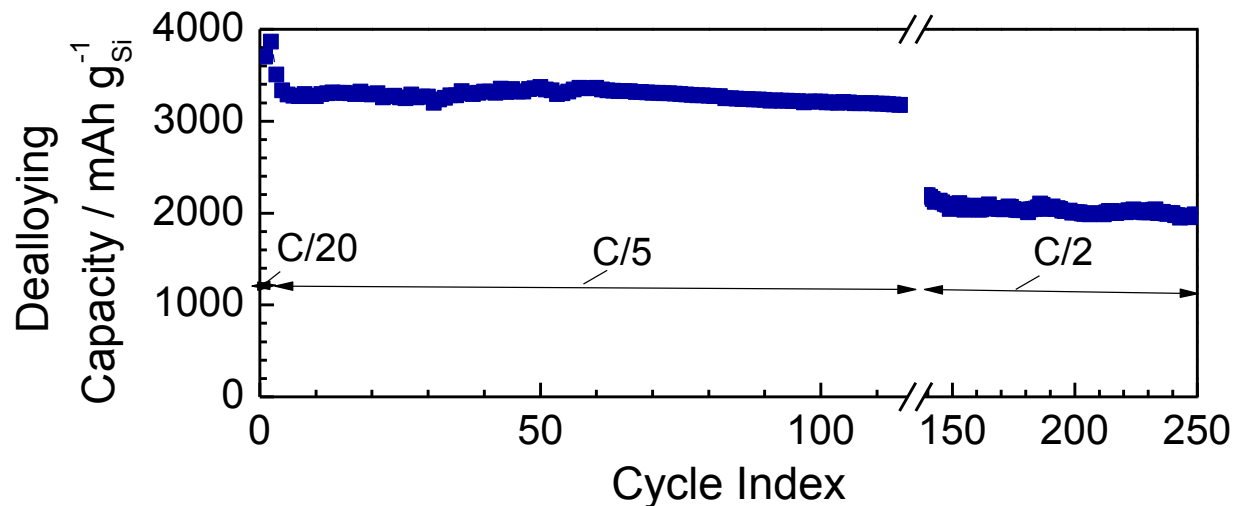

✓ Excellent stability of C-Si-CNT anode

✓ Ultra-high anode capacity

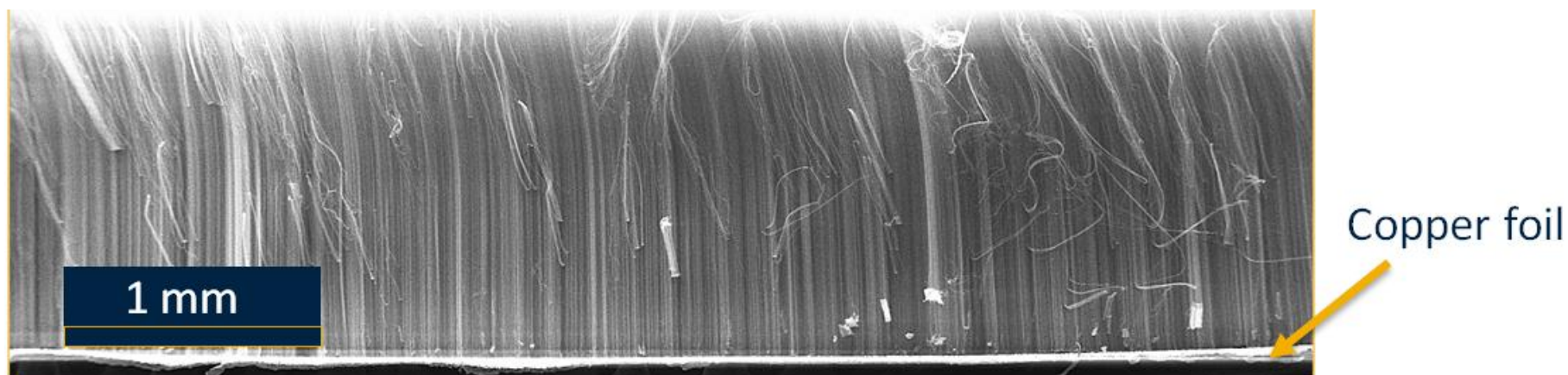

# Si-coated Vertically Aligned CNT Anodes

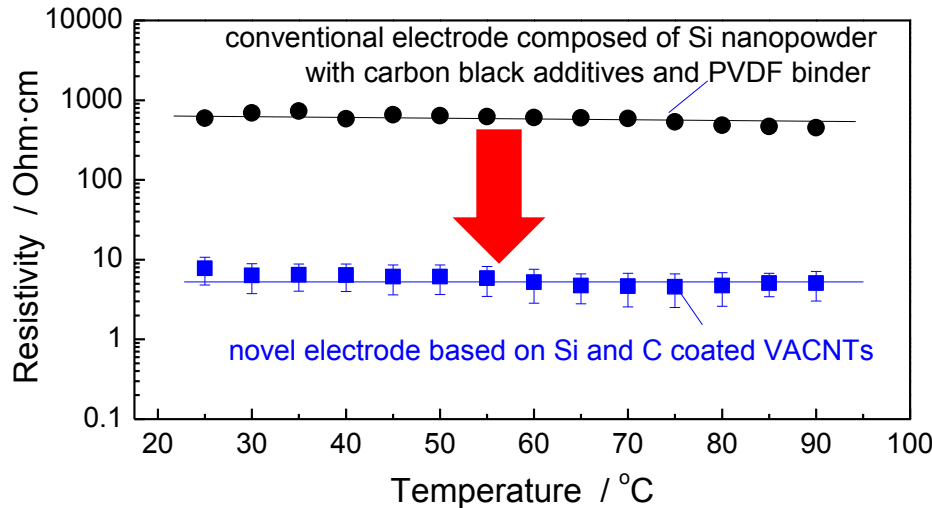

✓ > 100 times lower electrical resistance than that of nanopowder electrode with much higher density but comparable thickness

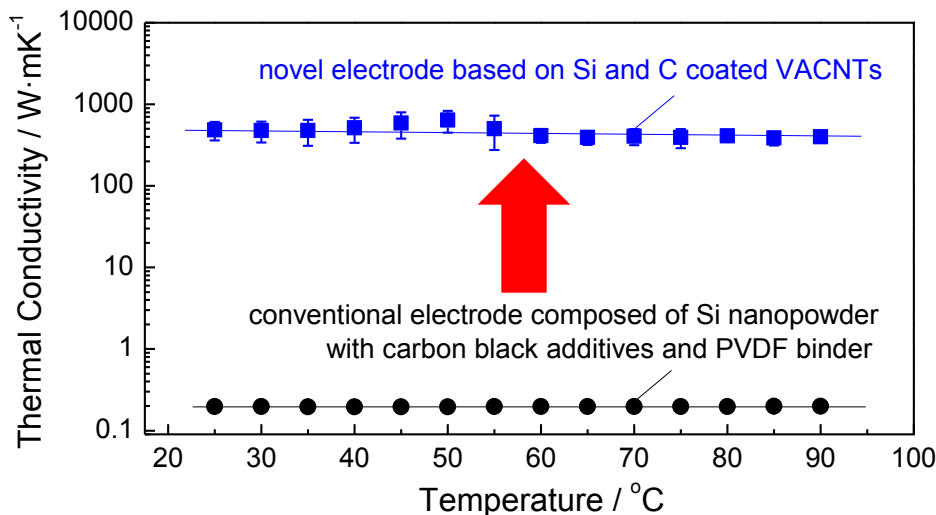

✓ > 1000 times higher thermal conductivity as compared to nanopowder electrode with much higher density but comparable thickness

✓ Excellent thermal properties of the CNT-Cu interface

# Supercapacitors

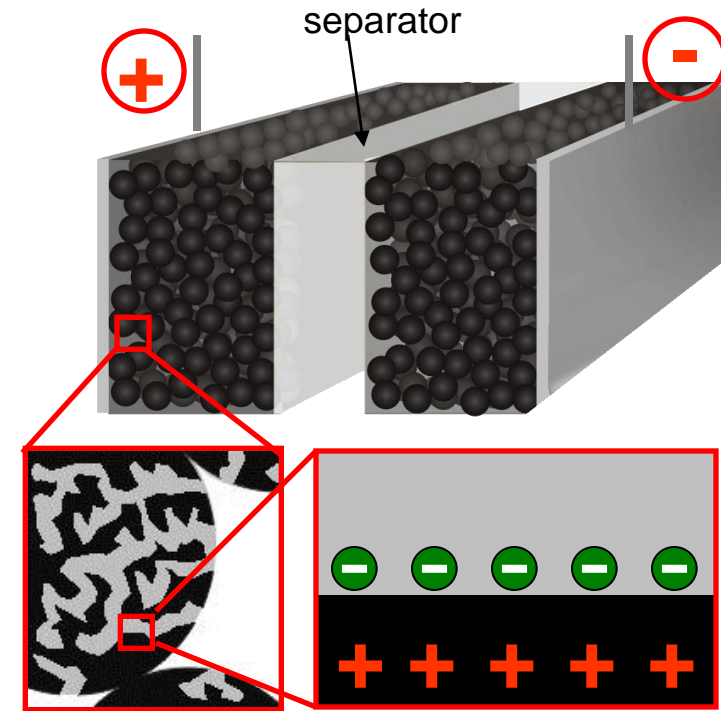
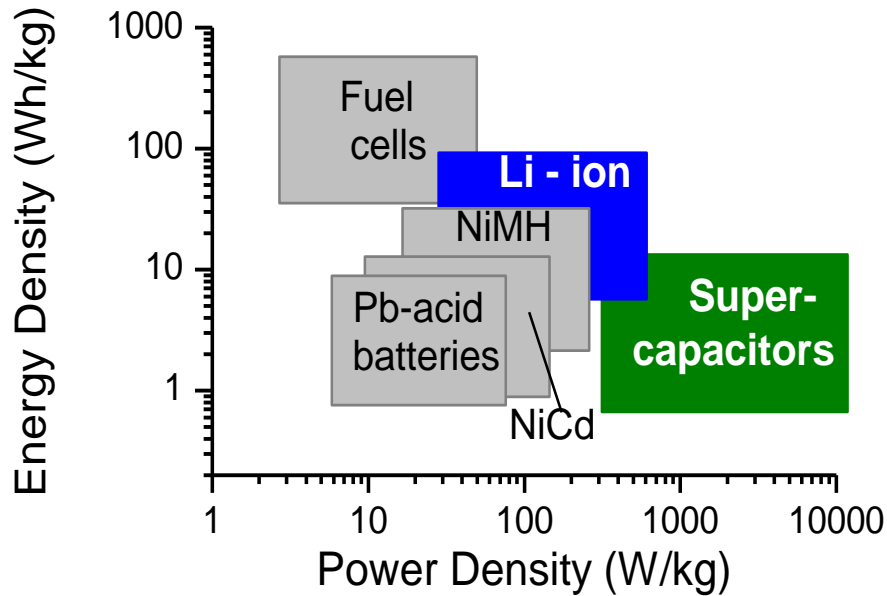

- **Charge storage:**
  - electrical double-layer (EDLC)
  - fast and reversible faradaic redox reaction (pseudocapacitance)
- **Energy storage depends on the ability of electrode to adsorb electrolyte ions under the applied potential**

# Supercapacitors

## Routes for Higher Energy Density:

Energy in supercapacitor device  $E \approx \frac{CV^2}{2} \cdot \frac{1}{8}$  due to packaging, two C in a series etc.

Capacitance (C) :

- (a) 6-30 uF/cm<sup>2</sup> in carbon
- (b) up to 200 uF/cm<sup>2</sup> in functionalized carbon
- (c) up to 200 uF/cm<sup>2</sup> in transition metal oxides  
(semi-bulk / surface layer storage possible)
- (d) up to 200 uF/cm<sup>2</sup> in conductive polymers  
(semi-bulk / surface layer storage possible)

## Limitations of Transitional Metal Oxides and Conductive Polymers:

- (a) low electrical conductivity
- (b) low surface area
- (c) (for conductive polymers): low stability

# Metal Oxide / CNT Fabric for Supercapacitors

## Advantages and Limitations of Transition Metal Oxide-based Supercapacitors

- Low cost transition metal oxides, which offer high specific capacitance (pseudocapacitance), are bad electrical conductors

**Project Idea:** Utilize Atomic Layer Deposition (ALD) to deposit thin layers of Metal oxide on CNT and other porous carbons

- Precursor and other sources vapors are pulsed into the chamber one at a time, separated by purging or evacuation periods
- Pulse step deposits a sub-monomolecular layer of the precursor onto the substrate
- Purge or evacuation step limits the reaction to the surface by removing the excess reaction gases

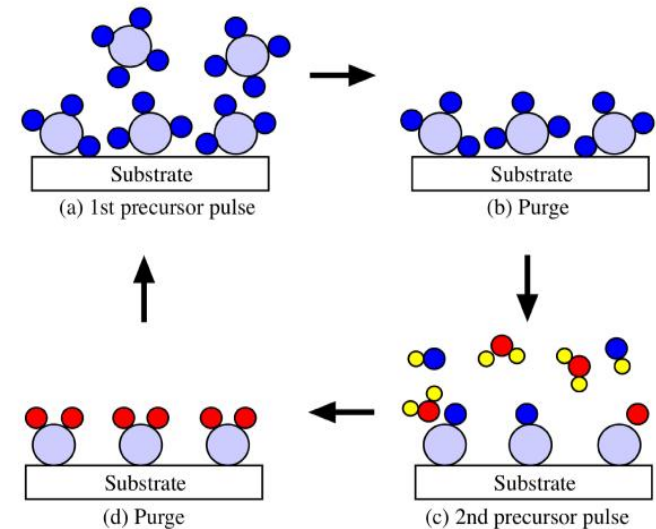

# Metal Oxide / CNT Fabric for Supercapacitors

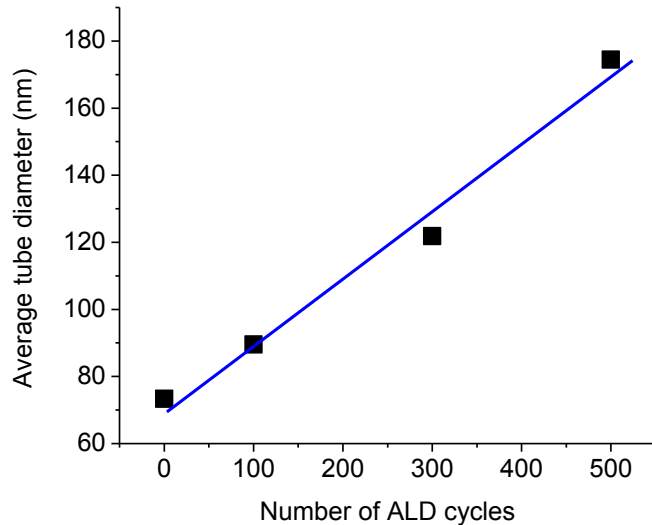

Coating thickness increases at **0.1nm/cycle**

➤ In an ideal case ALD is a surface-limited process, the average coating thickness or the average tube diameter should increase proportionally to the number of the ALD cycles

➤ An ImageJ software analysis of multiple SEM micrographs reveals linear increase in the average tube diameter with the number of ALD cycles, suggesting that the time allocated for the diffusion of the precursor gases into the porous structure in each cycle was sufficient for the reaction to be surface kinetics-controlled

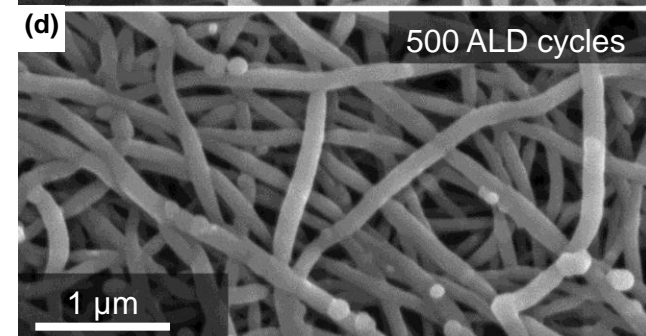
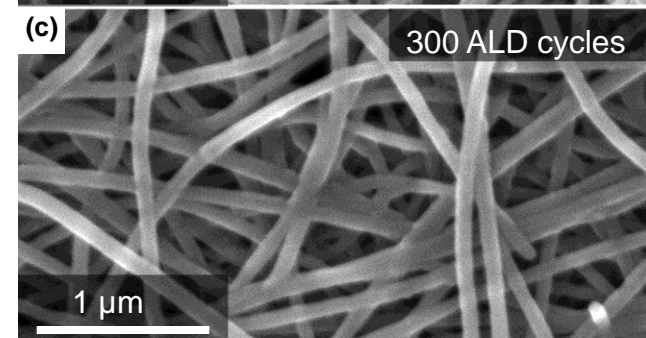
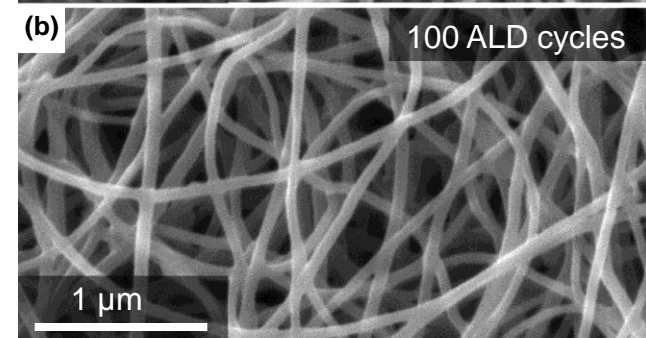
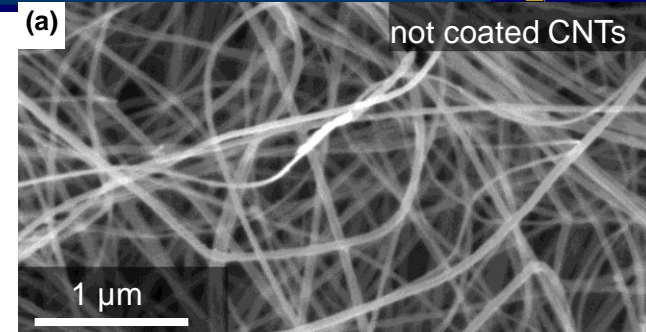

# Metal Oxide / CNT Fabric for Supercapacitors

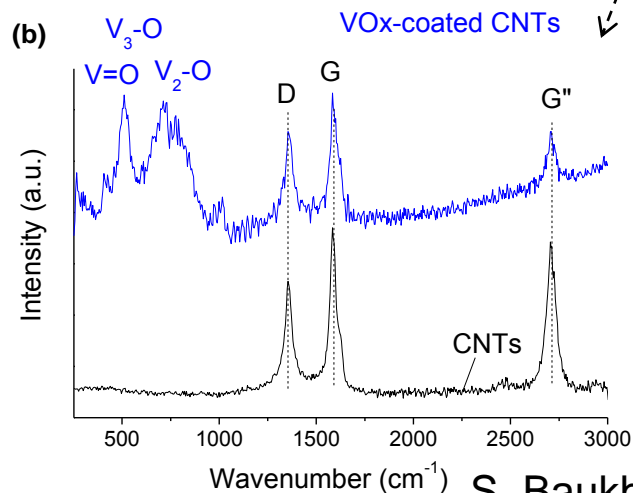
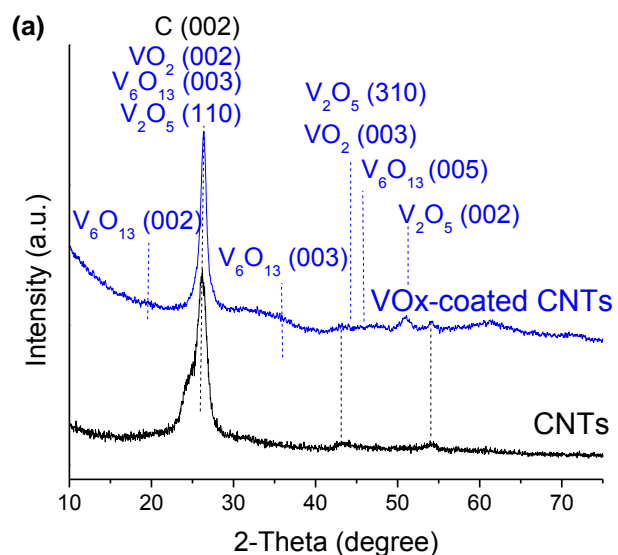

➤ Produced electrodes are dried at 170 C

➤ ALD coatings exhibit highly disordered microstructure and contain a range of stoichiometries (particularly evident from Raman spectroscopy measurements)

➤ V=O bonds are present in  $\text{VO}_2$ ,  $\text{V}_2\text{O}_5$ , and  $\text{V}_2\text{O}_3$ . Triply coordinated  $\text{V}_3\text{-O}$  bonds only appear in the chemical structure of  $\text{V}_2\text{O}_5$ , while doubly coordinated  $\text{V}_2\text{-O}$  bonds are present in the chemical structure of  $\text{VO}_2$  and  $\text{V}_2\text{O}_3$ .

# Metal Oxide / CNT Fabric for Supercapacitors

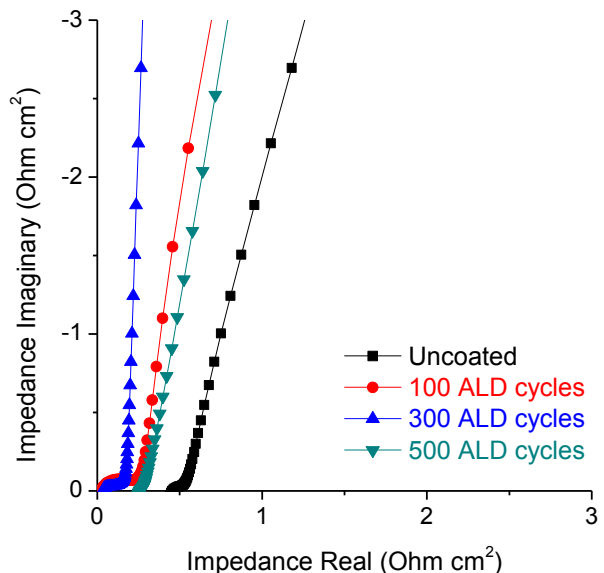
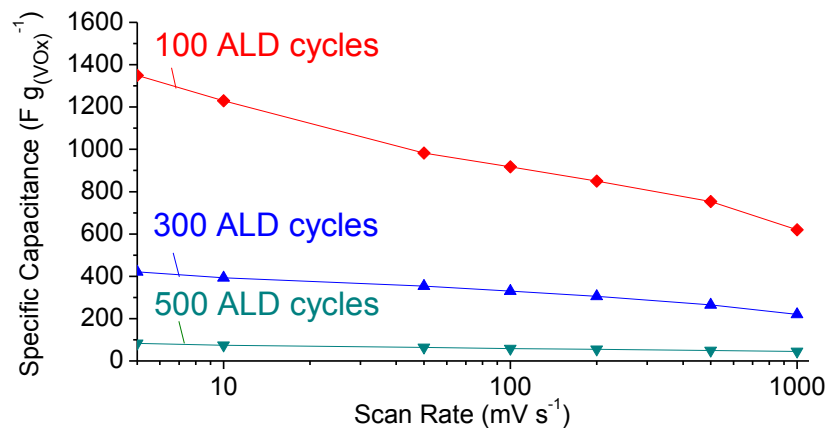
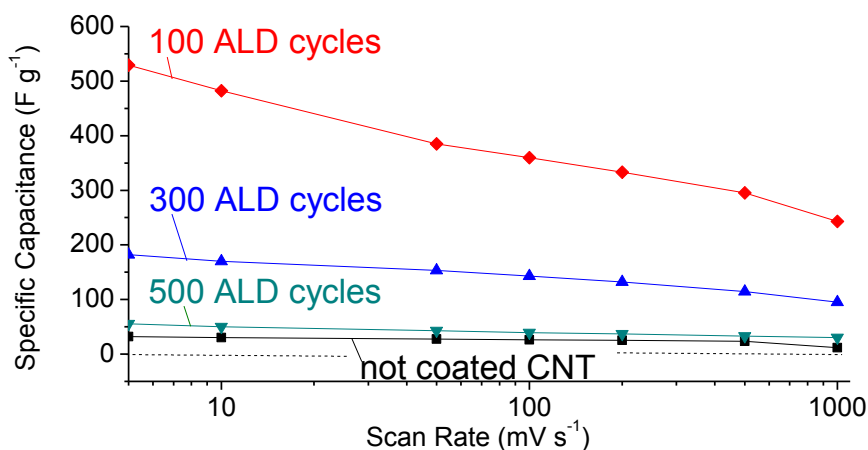

- Symmetric cell (coin cell); Electrode thickness: 100 μm
- Electrolyte: 6M LiCl (aqueous electrolyte)
- Capacitance normalized by the total mass of the composite

- 
- Vanadium oxide capacitance > 1300 F/g
  - ESR of the VO<sub>x</sub>-coated CNTs is very low (0.02 Ohm cm<sup>2</sup>)

# Metal Oxide / CNT Fabric for Supercapacitors

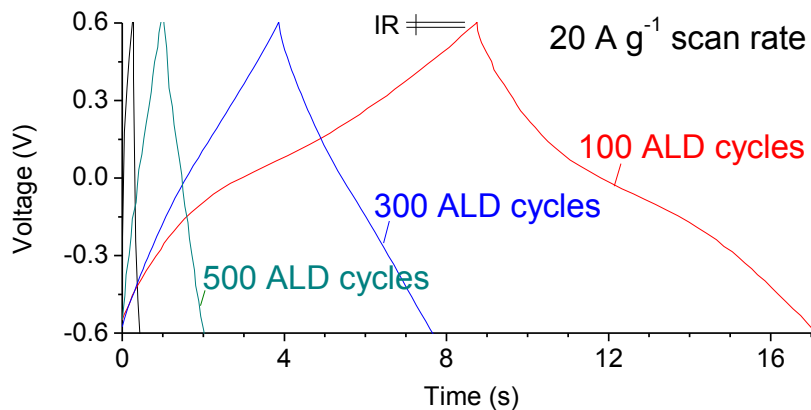
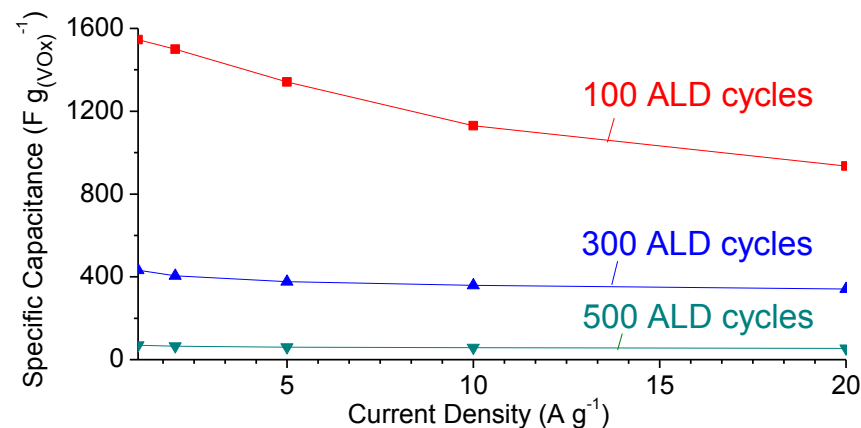
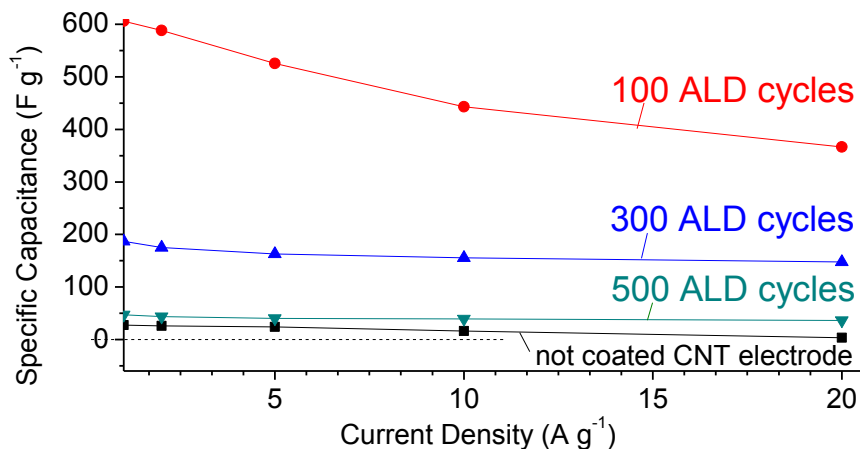

➤ Vanadium oxide capacitance > 1000  $F/g$  at very high current density of 20  $A/g$

➤ Very small IR drop at 20  $A/g$

# Metal Oxide / CNT Fabric for Supercapacitors (organic electrolytes)

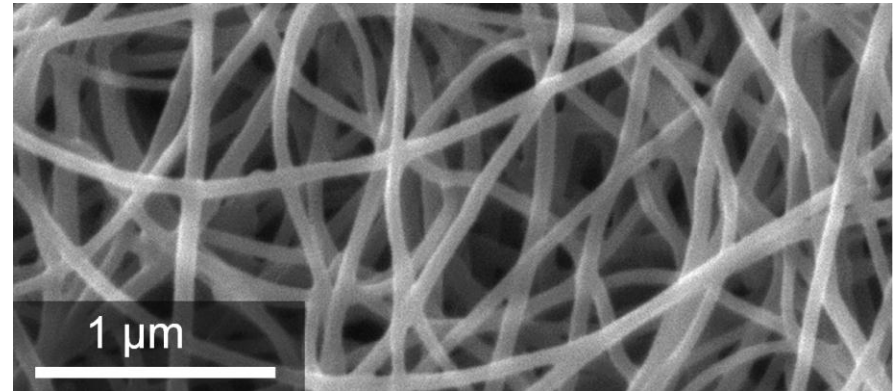
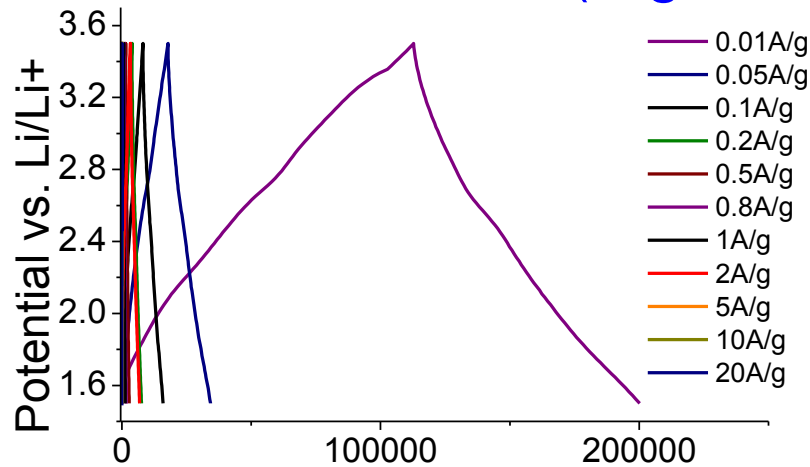

**Organic Electrolyte:** 1M  $\text{LiPF}_6$  in the mixture of carbonates (EC:DEC:DMC=1:1:1)

**Test configuration:** two-electrode cell vs. Li foil counter electrode

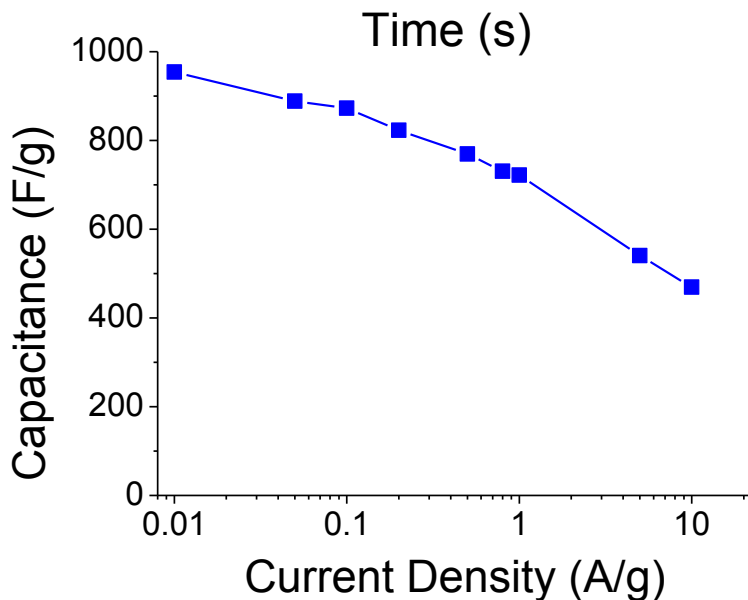

- Extremely promising performance (outstandingly high capacitance values)!!!
- Good rate capability
- In the future studies will attempt to use PC as a solvent to further improve the cell rate capability

# Polyaniline (PANI) for Supercapacitors

## Regular PANI

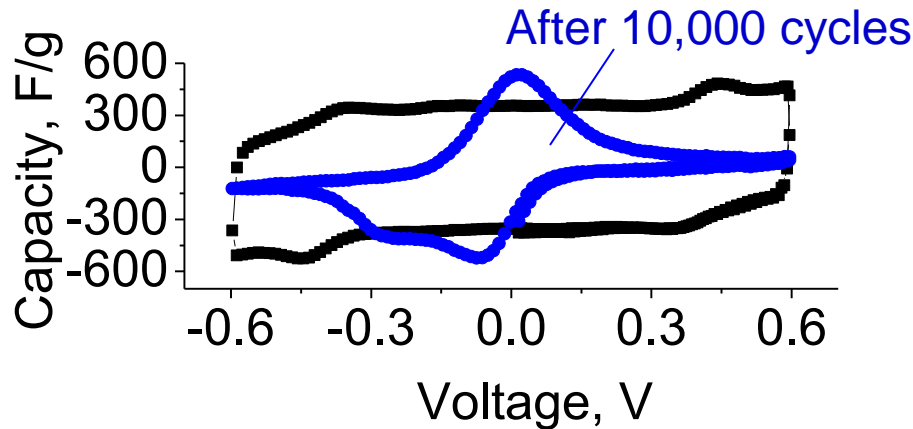

➤ PANI is inexpensive, conductive polymer with high specific capacitance



➤ Regular PANI electrodes show rapid performance degradation

➤ After 10,000 cycles dramatic decrease in capacitance and increase in resistance is observed (particularly at high potentials)

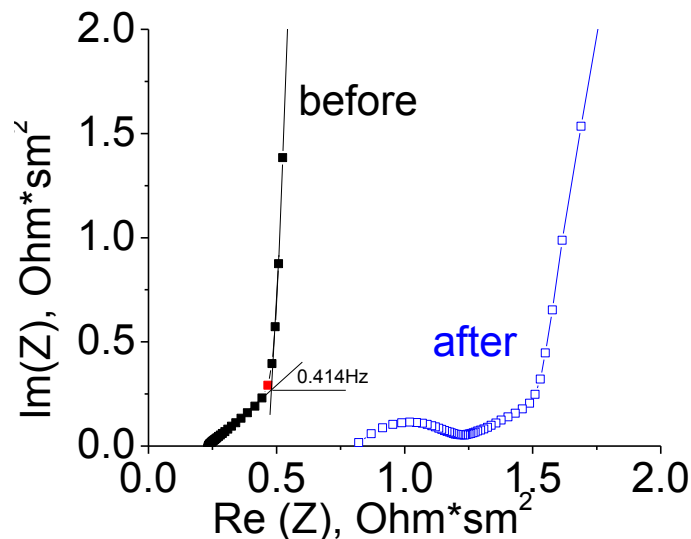

# Polyaniline (PANI) for Supercapacitors

## Regular PANI

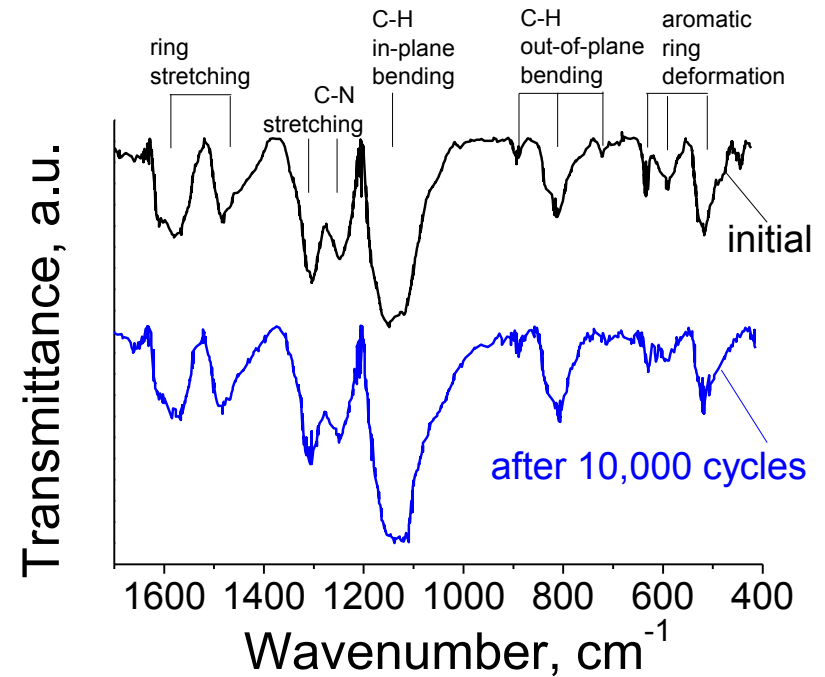
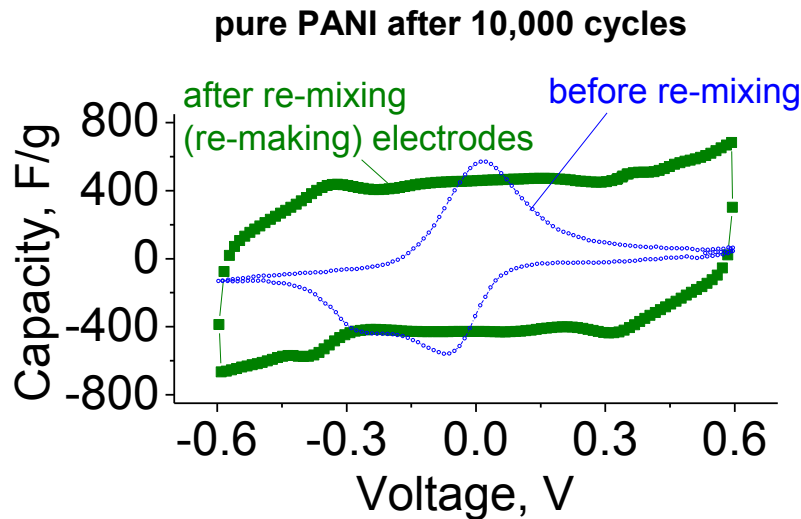

- Performance can be restored after re-mixing the electrodes with a binder
- No chemical modification detected after 10,000 cycles

# Nanodiamond (ND)-Embedded Polyaniline (PANI) for Supercapacitors

Aqueous electrolyte

▨ - initial  
■ - after 10,000 cycles

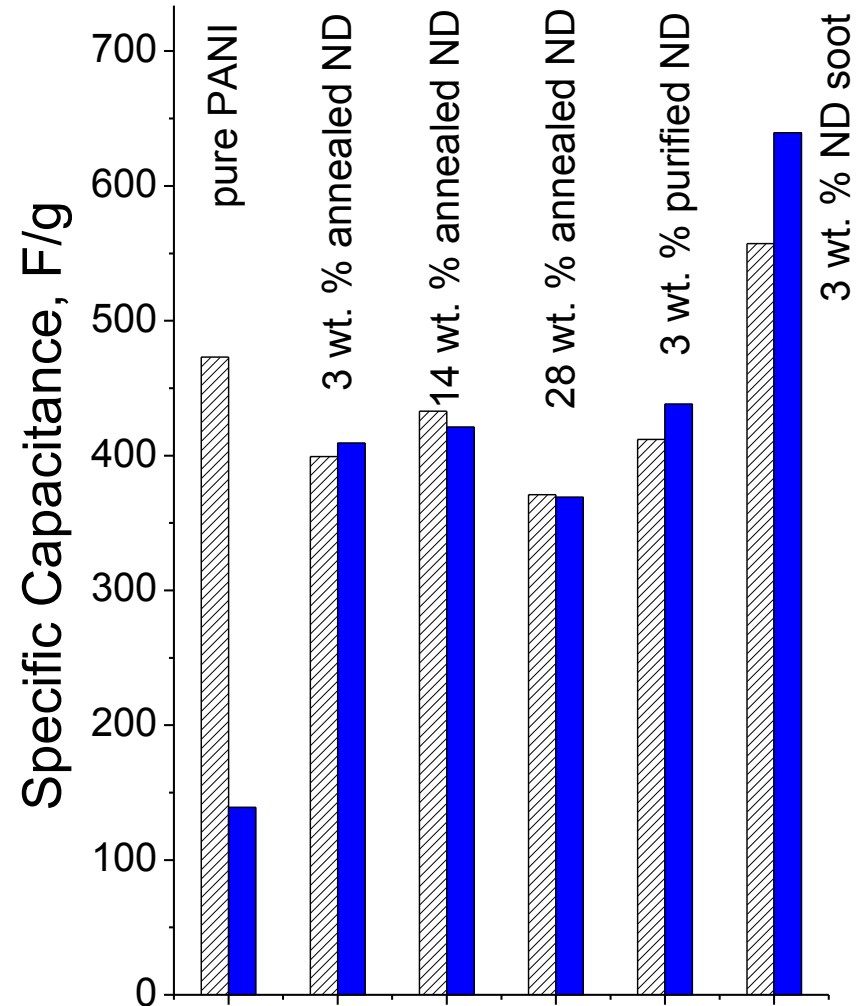
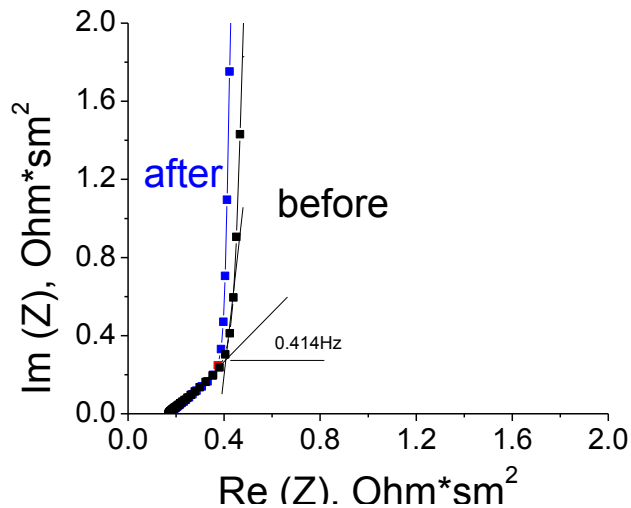
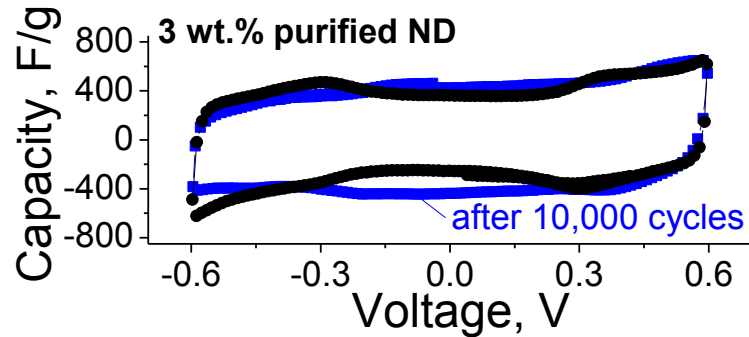

# PANI / CNT Fabric for Supercapacitors

*(work in progress)*

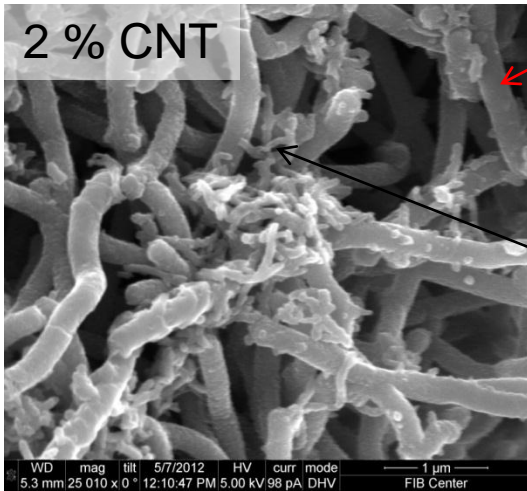

PANI nucleated  
on the CNT surface

PANI nanoparticles

- low wt. % CNT:  
individual PANI  
nanoparticles remaining

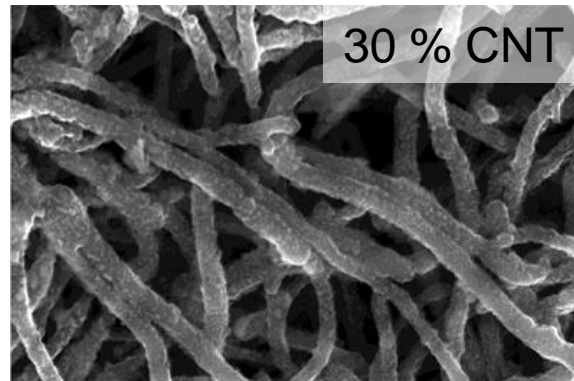
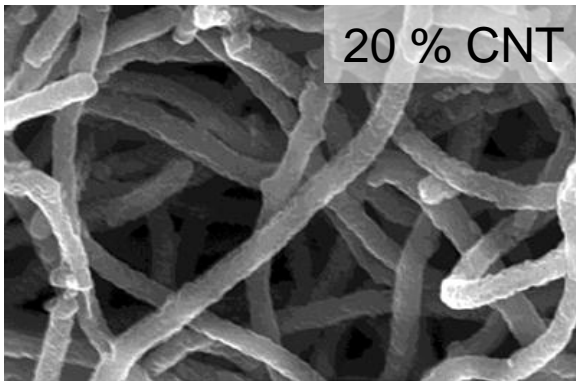

- high wt. % CNT:  
uniform PANI coating on  
CNTs

# Catalyst-Free Al Nanowire Growth by CVD

- Limitation of the CNT:
  - low DC conductivity (compared to Al and Cu)
  - low concentration of dangling bonds
- Metal nanowires:
  - typically grown electrochemically using AAO template
  - CVD growth (as CNTs) might offer more scalable process

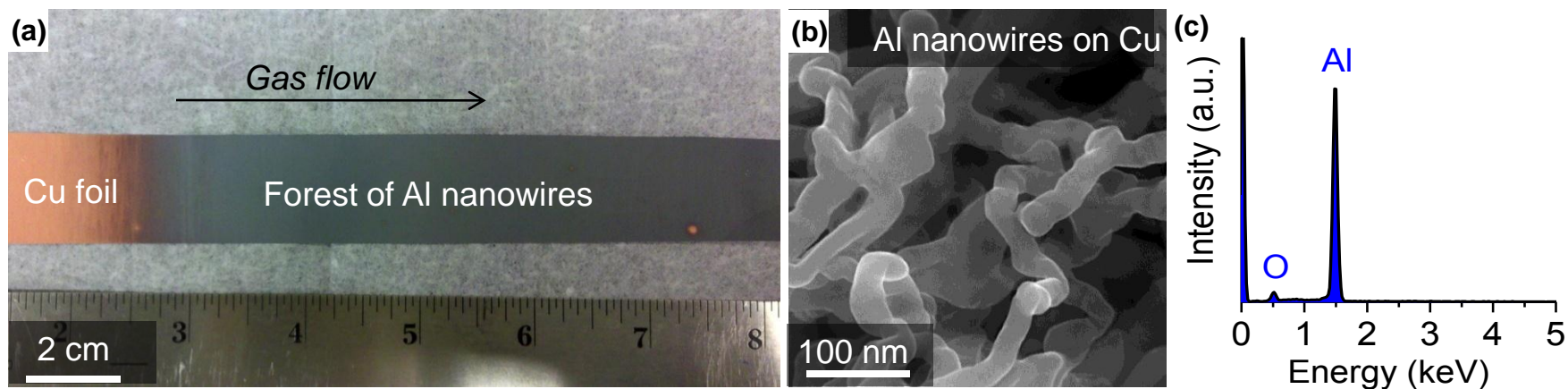

- Trimethylamine alane (TMAA) as an organometallic CVD precursor
- Catalyst-free

## Catalyst-Free Al Nanowire Growth by CVD

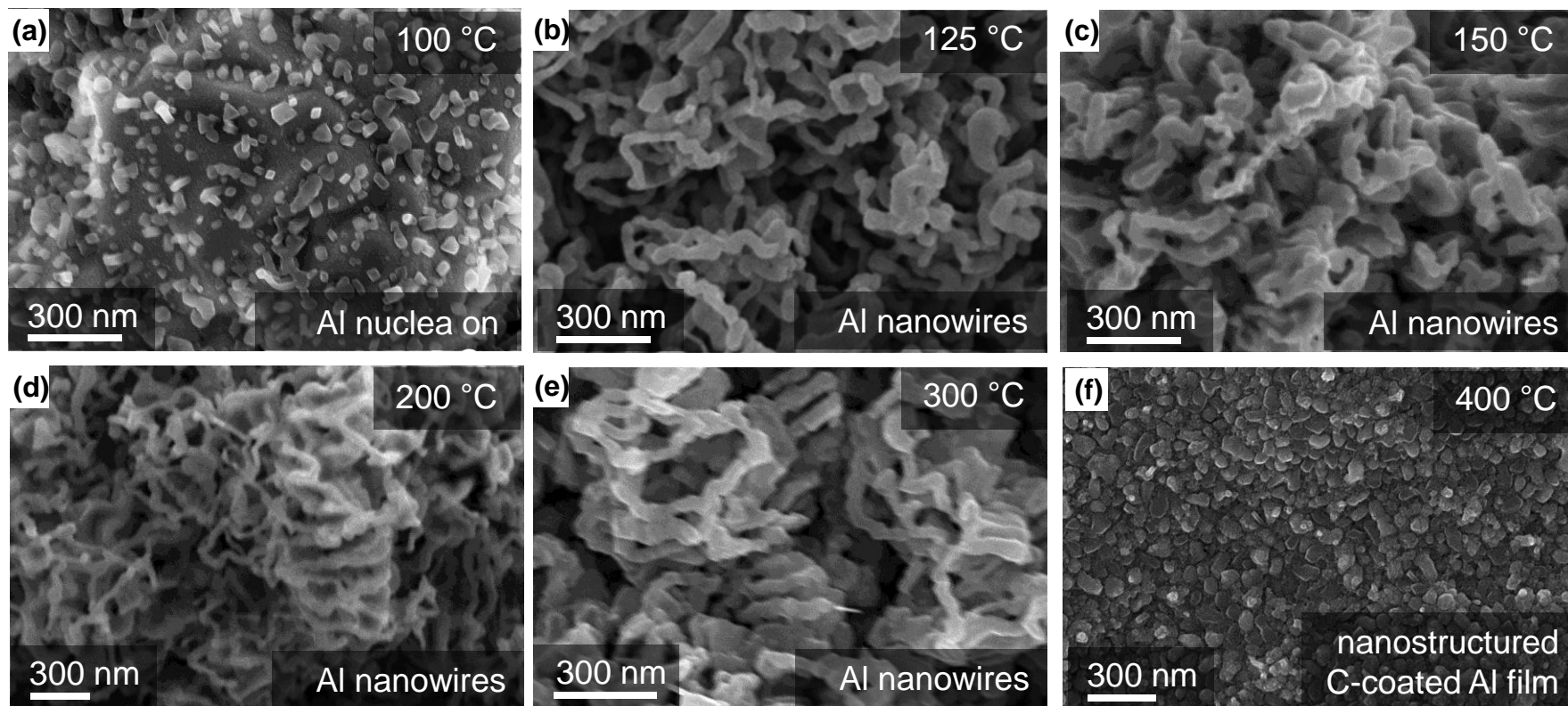

- Trimethylamine alane (TMAA) as an organometallic CVD precursor
- Catalyst-free
- Low synthesis temperature: 100-300 °C

# Catalyst-Free Al Nanowire Growth by CVD

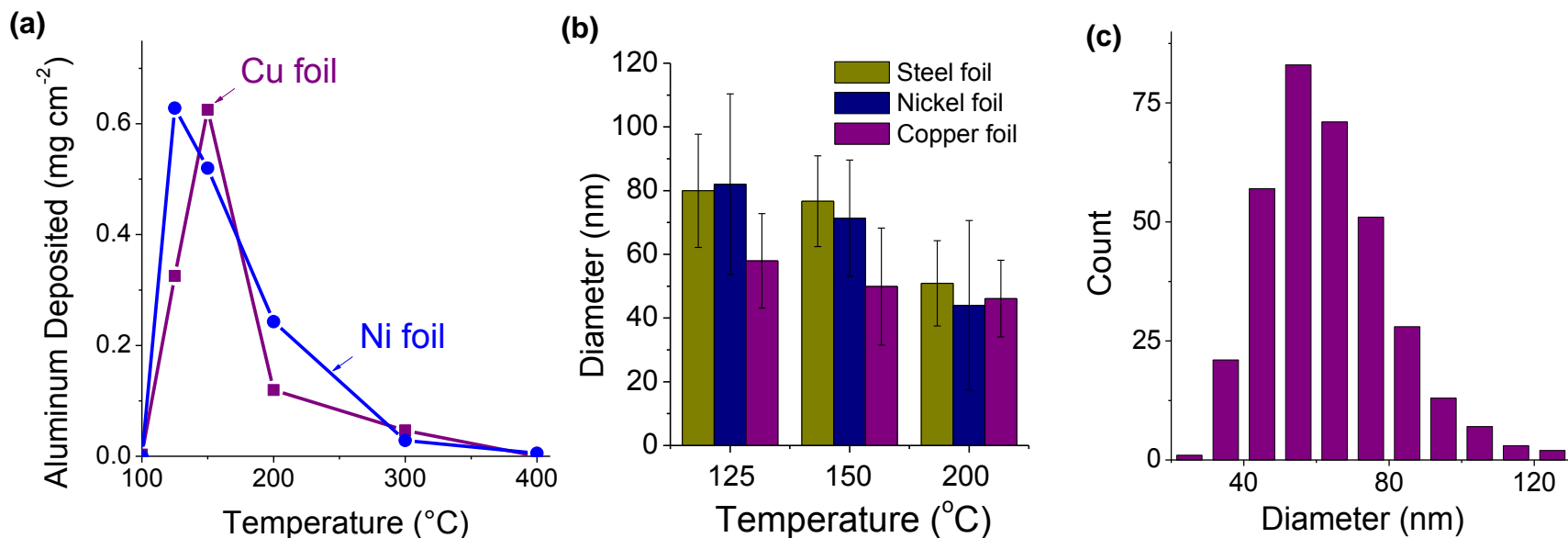

- Narrow diameter distribution
- Low temperature (100-200  $^{\circ}\text{C}$ )
- Uniform diameter along the length of the nanowires; no increase in the nanowire diameter with time, suggesting tip-based growth (likely due to the self-catalytic type of reaction involved)

# Catalyst-Free Al Nanowire Growth by CVD

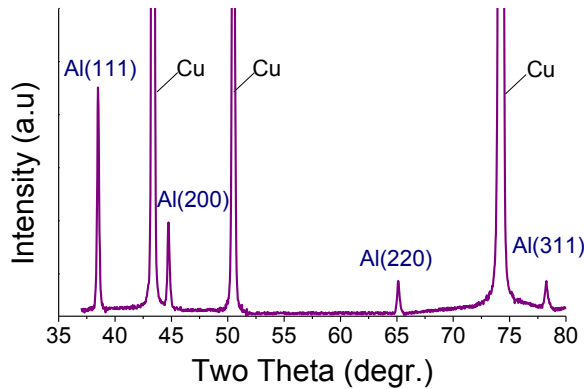
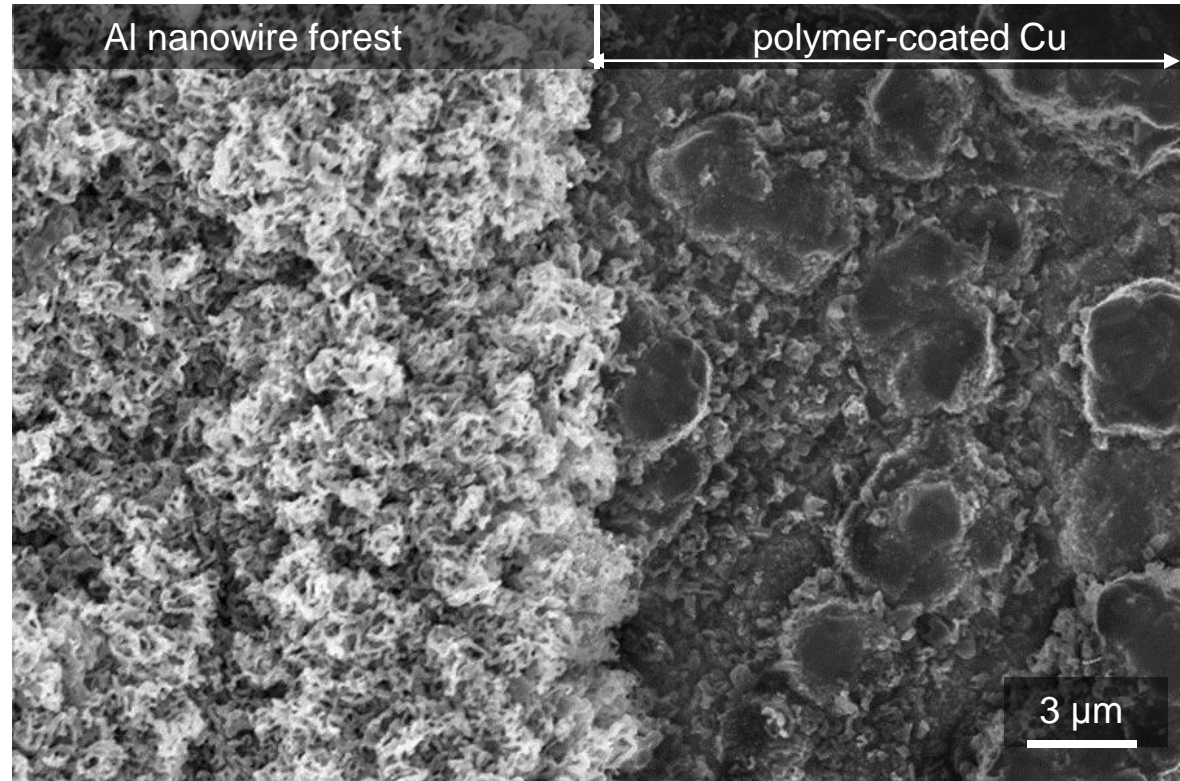
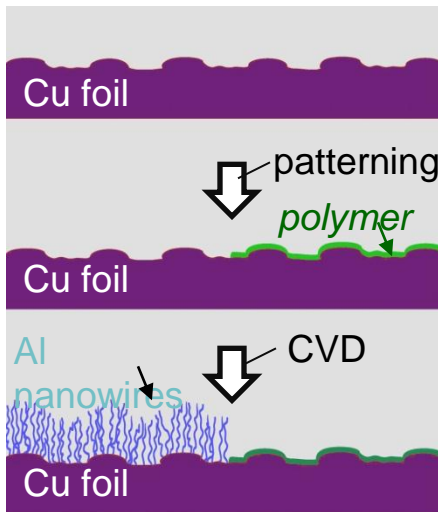

- Polymer layer on the foil surface prevents Al nanowire growth. Therefore, patterned growth becomes feasible

# ALD-coated Al Nanowires

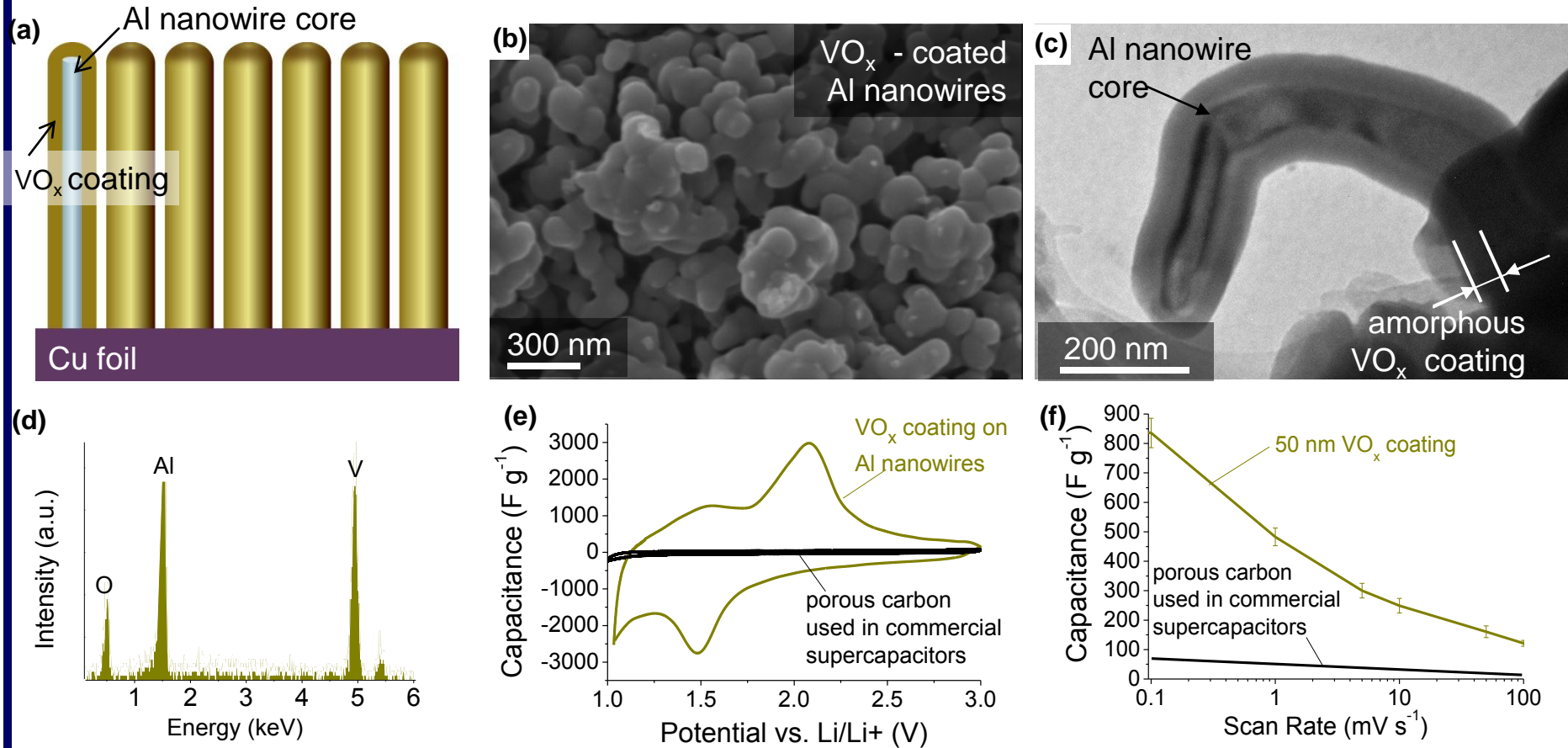

- Battery-like AND pseudocapacitor-like behavior
- Gravimetric capacitance of up to 887 F/g is 4-10 time higher than C
- Volumetric capacitance of 1390-1950 F/cc is 10-40 times higher than that of C in the same electrolyte

## Acknowledgement

- Dr. “Les” Lee
- Collaborators (Prof. Igor Luzinov, Dr. Jud Ready, Dr. Zdyrko, NanoComp, *others*)

## Support



## Disclosure

- Mentioned Georgia Tech patents have been licensed to Sila Nanotechnologies, Inc.; Dr. Yushin & GT is a stock holder in Sila