



# NAVAL POSTGRADUATE SCHOOL

MONTEREY, CALIFORNIA

## THESIS

**A TECHNICAL FEASIBILITY STUDY OF A GREEN AREA**

by

Spyridon Theofilos Lamprou

September 2012

Thesis Advisor:  
Second Reader:

Fotis Papoulias  
Nikitas Nikitakos

**Approved for public release; distribution is unlimited**

THIS PAGE INTENTIONALLY LEFT BLANK

REPORT DOCUMENTATION PAGE			Form Approved OMB No. 0704-0188	
Public reporting burden for this collection of information is estimated to average 1 hour per response, including the time for reviewing instruction, searching existing data sources, gathering and maintaining the data needed, and completing and reviewing the collection of information. Send comments regarding this burden estimate or any other aspect of this collection of information, including suggestions for reducing this burden, to Washington headquarters Services, Directorate for Information Operations and Reports, 1215 Jefferson Davis Highway, Suite 1204, Arlington, VA 22202-4302, and to the Office of Management and Budget, Paperwork Reduction Project (0704-0188) Washington DC 20503.				
1. AGENCY USE ONLY (Leave blank)		2. REPORT DATE September 2012	3. REPORT TYPE AND DATES COVERED Master's Thesis	
4. TITLE AND SUBTITLE A Technical Feasibility Study of a Green Area			5. FUNDING NUMBERS	
6. AUTHOR(S) Spyridon Theofilos Lamprou			8. PERFORMING ORGANIZATION REPORT NUMBER	
7. PERFORMING ORGANIZATION NAME(S) AND ADDRESS(ES) Naval Postgraduate School Monterey, CA 93943-5000			10. SPONSORING/MONITORING AGENCY REPORT NUMBER	
9. SPONSORING /MONITORING AGENCY NAME(S) AND ADDRESS(ES) N/A			11. SUPPLEMENTARY NOTES The views expressed in this thesis are those of the author and do not reflect the official policy or position of the Department of Defense or the U.S. Government. IRB Protocol number ___N/A___.	
12a. DISTRIBUTION / AVAILABILITY STATEMENT Approved for public release; distribution is unlimited			12b. DISTRIBUTION CODE A	
13. ABSTRACT (maximum 200 words)  A feasibility study of the creation of a community (either on or off grid), whose energy needs are fully covered by renewable energy sources, is a complicated task. The study may suggest and lead to policy and actions to minimize or even eliminate energy losses, and can guide us to zero emission cities and naval bases. This has the benefits of assisting ecology and petroleum-based fuel economy. During this study, not only an energy balance is estimated, but also the economic feasibility of the project is examined, in order to achieve a reasonable balance of initial and maintenance cost of the renewable energy sources and fuel economy.  Following a comprehensive review of available sources, the study starts with an area selection. The geographical area selected is a large island off the main metropolitan region of Greece. It presents several challenges, mainly due to its size, diverse energy needs including a major naval base, and a widely fluctuating population with varying energy needs. These needs are analyzed along with the energy sources available in the area. A variety of optimization programs is selected offering several advantages and disadvantages. A set of parametric runs is conducted in order to reveal the most promising solutions from both a technical and an economic sense.				
14. SUBJECT TERMS Wind turbine, Solar panel, Hybrid system, Renewable energy sources, Cost analysis, Case study evaluation			15. NUMBER OF PAGES 101	
			16. PRICE CODE	
17. SECURITY CLASSIFICATION OF REPORT Unclassified	18. SECURITY CLASSIFICATION OF THIS PAGE Unclassified	19. SECURITY CLASSIFICATION OF ABSTRACT Unclassified	20. LIMITATION OF ABSTRACT UU	

NSN 7540-01-280-5500

Standard Form 298 (Rev. 8-98)  
Prescribed by ANSI Std. Z39.18

THIS PAGE INTENTIONALLY LEFT BLANK

**Approved for public release; distribution is unlimited**

**A TECHNICAL FEASIBILITY STUDY OF A GREEN AREA**

Spyridon Theofilos Lamprou  
Lieutenant Grade, Hellenic Navy  
B.S., Hellenic Naval Academy, 2002

Submitted in partial fulfillment of the  
requirements for the degree of

**MASTER OF SCIENCE IN MECHANICAL ENGINEERING**

and

**MECHANICAL ENGINEER DEGREE**

from the

**NAVAL POSTGRADUATE SCHOOL  
September 2012**

Author: Spyridon Theofilos Lamprou

Approved by: Fotis Papoulias  
Thesis Advisor

Nikitas Nikitakos  
Second Reader

Knox T. Millsaps  
Chair, Department of Mechanical and Aerospace  
Engineering

THIS PAGE INTENTIONALLY LEFT BLANK

## **ABSTRACT**

A feasibility study of the creation of a community (either on or off grid), whose energy needs are fully covered by renewable energy sources, is a complicated task. The study may suggest and lead to policy and actions to minimize or even eliminate energy losses, and can guide us to zero emission cities and naval bases. This has the benefits of assisting ecology and petroleum-based fuel economy. During this study, not only an energy balance is estimated, but also the economic feasibility of the project is examined, in order to achieve a reasonable balance of initial and maintenance cost of the renewable energy sources and fuel economy.

Following a comprehensive review of available sources, the study starts with an area selection. The geographical area selected is a large island off the main metropolitan region of Greece. It presents several challenges, mainly due to its size, diverse energy needs including a major naval base, and a widely fluctuating population with varying energy needs. These needs are analyzed along with the energy sources available in the area. A variety of optimization programs is selected offering several advantages and disadvantages. A set of parametric runs is conducted in order to reveal the most promising solutions from both a technical and an economic sense.

THIS PAGE INTENTIONALLY LEFT BLANK

# TABLE OF CONTENTS

I.	INTRODUCTION.....	1
A.	MOTIVATION.....	1
B.	OBJECTIVES.....	2
II.	RENEWABLE ENERGY SOURCES .....	5
A.	CATEGORIES.....	5
1.	Solar Energy.....	5
2.	Wind Power .....	6
3.	Wave Power.....	8
4.	Tidal Power.....	9
5.	Geothermal Energy.....	10
6.	Biomass and Biofuels .....	11
7.	Earthquakes .....	12
8.	Hydrogen Fuel Cells .....	13
B.	ADVANTAGES .....	13
C.	DISADVANTAGES .....	14
III.	COMMUNITY ORGANIZATION .....	15
A.	ENERGY LOSSES.....	16
1.	Emissions.....	16
2.	Wastes .....	16
3.	Heat Losses.....	16
B.	RETRIEVAL METHODS .....	17
1.	Emissions.....	17
2.	Wastes .....	19
3.	Heat Losses.....	20
IV.	AREA-TERRITORIAL EXAMINATION.....	21
A.	MORPHOLOGY .....	23
B.	CLIMATE .....	24
C.	ENERGY NEEDS.....	25
1.	Community Needs .....	25
2.	Naval Base Needs.....	26
D.	RENEWABLE ENERGY SOURCES POTENTIAL .....	27
1.	Wind Power .....	27
2.	Solar Power .....	27
3.	Geothermal Power .....	30
4.	Wave Power.....	31
5.	Tidal Power.....	32
6.	Biomass and Biofuels .....	32
V.	OPTIMIZATION .....	33
A.	OPTIMIZATION PROGRAMS.....	33
1.	HOGA [8].....	33

2.	HOMER [11] .....	35
3.	Hybrid2 [10] .....	36
4.	RETScreen [12] .....	38
5.	ViPOR [13] .....	40
6.	Overall .....	41
B.	DATA .....	42
1.	Residential Energy Needs .....	43
2.	Naval Base Needs .....	43
3.	Wind Energy .....	44
4.	Solar Power .....	46
5.	Other RES .....	47
6.	Other Components .....	47
C.	ENERGY SOURCE OPTIMIZATION .....	48
1.	HOMER .....	49
2.	HOGA .....	57
3.	RETScreen .....	59
4.	Hybrid2 and ViPOR .....	61
D.	SOURCE LOCATIONS .....	61
1.	Wind Turbines .....	61
2.	Photovoltaic Panels .....	63
E.	ENERGY BALANCE AND EXCESS .....	65
F.	EFFICIENCY .....	67
VI.	SYSTEM ANALYSIS .....	71
A.	ECONOMY .....	72
B.	AVAILABILITY .....	74
C.	RELIABILITY .....	75
D.	INITIAL COST RECOVERY .....	76
E.	FUTURE ENERGY NEEDS .....	76
VII.	CONCLUSIONS AND RECOMMENDATIONS .....	79
	LIST OF REFERENCES .....	81
	INITIAL DISTRIBUTION LIST .....	83

## LIST OF FIGURES

Figure 1.	Photovoltaic Solar Panels.....	6
Figure 2.	Iderdrola's Scopies Onshore Wind Farm in Greece .....	7
Figure 3.	Offshore Wind Farm .....	7
Figure 4.	Offshore Pelamis Wave Energy Converter. From [3].....	8
Figure 5.	Onshore LIMPET Wave Energy Converter. From [3] .....	8
Figure 6.	Under Water Stream Turbine .....	9
Figure 7.	La Rance Tidal Power Plant in Brittani, France .....	10
Figure 8.	Part of Installation of a Geothermal Heating Pump .....	11
Figure 9.	Geothermal Power Plant in Iceland .....	11
Figure 10.	Biomass Power Plant .....	12
Figure 11.	Projected Residential Electricity Consumption. From [7].....	15
Figure 12.	Electric City Car. From [3] .....	18
Figure 13.	Electric Boat. From [3].....	18
Figure 14.	Composter .....	19
Figure 15.	Wastewater Treatment in Psytalia Island, Greece.....	20
Figure 16.	Fireplace Furnace.....	20
Figure 17.	Geographical Location of Salamis Island and Athens. ....	22
Figure 18.	Electrical Supply System of Salamis. From [4] .....	22
Figure 19.	Installed Energy Sources in Salamis. From [4].....	23
Figure 20.	Natural Gas and Oil Distribution System in Salamis. From[4] .....	23
Figure 21.	Satellite View of Salamis .....	24
Figure 22.	Wind Potential of Salamis. From [4] .....	27
Figure 23.	Photovoltaic Potential of Horizontally Mounted Modules. From [5].....	29
Figure 24.	Photovoltaic Potential of Optimally Mounted Modules. From [5] .....	30
Figure 25.	Geographic Overview of Salamis and Saronic Gulf.....	31
Figure 26.	Directional Intensity Diagrams of Waves at the Entrance of Saronic Gulf. From [6] .....	32
Figure 27.	Elements for a Generic Case in HOGA .....	34
Figure 28.	Sample of Sources and Loads of HOMER .....	36
Figure 29.	The Structure of Hybrid2 .....	37
Figure 30.	An Overview of a System in Hybrid2 .....	38
Figure 31.	General View of RETScreen 4 .....	39
Figure 32.	Overview of RETScreen Plus .....	40
Figure 33.	Sample of Results of ViPOR .....	41
Figure 34.	Typical Wind Turbine Power Curve .....	45
Figure 35.	Typical Diagram $\eta(\%)$ vs. Output Power (% Rated Power) of an Inverter .....	48
Figure 36.	Cash Flow Summary .....	53
Figure 37.	Annual Cost Summary.....	54
Figure 38.	Monthly Average Electric Production.....	54
Figure 39.	Annual PVP Power Production.....	55
Figure 40.	Annual Wind Turbine Production.....	55

Figure 41.	Annual Inverter Production .....	56
Figure 42.	Nominal Power Production of Components.....	58
Figure 43.	Cost by Component.....	58
Figure 44.	Cost Summary HOGA .....	58
Figure 45.	System Inputs and Technical Data .....	59
Figure 46.	Proposed System Characteristics .....	60
Figure 47.	Emission Analysis.....	60
Figure 48.	Financial Analysis.....	60
Figure 49.	Wind Turbine Sites .....	63
Figure 50.	PVP Sites .....	65

## LIST OF TABLES

Table 1.	Mean Temperature and Wind Values the Last 10 Years.....	25
Table 2.	Annual Energy Needs of Salamis. From [4].....	26
Table 3.	Abilities of Optimization Programs.....	42
Table 4.	The Annual Energy Consumption of Residences in Salamis.....	43
Table 5.	The Annual Energy Consumption of the Naval Base in Salamis .....	44
Table 6.	Significant Wind Turbine Specifications.....	45
Table 7.	Monthly Average Solar Radiation the Last Four Years.....	46
Table 8.	Significant Technical Specifications of an Inverter .....	48
Table 9.	Cases Subject to Optimization .....	50
Table 10.	Optimization Results of Each Case .....	51
Table 11.	System Architecture and Cost Summary.....	52
Table 12.	Costs Analysis .....	53
Table 13.	Electrical System Summary.....	54
Table 14.	Component Summary.....	55
Table 15.	Grid Summary .....	56
Table 16.	Emission Summary.....	56
Table 17.	System Summary HOGA.....	57
Table 18.	Energy Balance and Excess.....	67
Table 19.	Technical and Financial Ratios.....	68
Table 20.	Project Efficiencies .....	69
Table 21.	Power Plants Efficiencies. After [17].....	70

THIS PAGE INTENTIONALLY LEFT BLANK

## LIST OF ACRONYMS AND ABBREVIATIONS

COE	Cost of energy
DIC	Daily individual consumption
DRC	Daily residential consumption
$E_{cs}$	Capacity shortage
$E_{ren}$	Renewable energy
$E_{tot}$	Total energy
$f_{cs}$	Capacity shortage fraction
$f_{ren}$	Renewable fraction
GHG	Greenhouse gases
HLD	House losses deviation
$H_{ren}$	Renewable heat
$H_{tot}$	Total heat
NPC	Net present cost
O&M	Operational and maintenance
PVP	Photovoltaic panel
RES	Renewable energy source
TC	Total consumption
$\eta$	Efficiency

THIS PAGE INTENTIONALLY LEFT BLANK

## **ACKNOWLEDGMENTS**

I would like to express my gratitude and appreciation to the following people:

First of all, I would to thank my wife, Triantafyllia Papapetrou, for her patience the last four years. Her support, understanding and help boost me to achieve my goals.

My mother, Sevasti Fotini Kiorpe, for inculcating me the value of education and the persistence for success.

My parents in law for being there, anytime I needed them.

Professor Fotis Papoulias for his cooperation. His guidance and remarks helped in being a better researcher. His experience helped overcome all the difficulties I faced.

Professor Nikitas Nikitakos for helping me clarify any question I had. His knowledge and motivation were vital for the completion of my thesis.

THIS PAGE INTENTIONALLY LEFT BLANK

# I. INTRODUCTION

## A. MOTIVATION

In the past years, humanity is facing the consequences of global warming, which are extreme weather phenomena and territorial climate changes worldwide. The massive consumption of energy produced by fossil fuels and their products resulted in the continuous and unpredictable rise in their price, while the emissions of their combustion contribute to the extended environmental pollution. The combination of the above facts revived the need of environmental friendly and free energy sources, like wind, solar, wave and geothermal power, known as renewable energy sources (RES).

While fossil fuels are not spread evenly everywhere across the world and have great costs of extraction and procession, RES can be found almost all over the world. They are free, sustainable and abundant. On the other hand, since there are big variations of those sources from area to area and their density is significantly lower than fossil fuels, the need to increase their efficiency by using larger areas increases the initial investment cost.

The economy of every developed and developing country is based on fossil fuels and the world oil price is the main factor for further development. Moreover, there is a continuously growing environmental awareness along governments, trying to limit the consumption of fossil fuels and their emissions. One way to have the desired outcome is by using RES. Depending on the territory, those sources can be sufficient to provide more than enough energy. Since there are many different RES and many methods and techniques, such as wind turbines and solar panels, of converting them to exploitable energies, there is a flexibility to use the proper combination of RES in order to have the best benefits.

This study will examine the use of RES as the only energy provider over a territory and if there is the capability for this territory to be off grid and/or on grid as an energy source.

## **B. OBJECTIVES**

The European Union has established a directive since 1997, promoting the use of RES. According to that directive, RES should provide a 20% of the total energy consumption of any country member, by 2020. That way, EU tries to achieve multiple targets, such as increased safety of energy supplies, decreased emissions and fuel consumption.

The creation of a community on grid and/or off grid, whose energy needs are fully covered by renewable energy sources, with actions to minimize or even eliminate energy losses, can guide us to zero emission cities and military bases. There are several examples of green areas, such as the Samsøe Island in Denmark, Eigg Island in Scotland and Utsira Island in Norway, where RES covers all energy needs. The common factor of those islands is that they are small communities with low population and without any major energy consumer like a big naval base, while they can be easily off grid.

The examination of an area with no constant energy needs, due to large variation in population and due to large energy consumers, not only is a challenge, but also gives the opportunity to expand the use of RES into greater areas or even a whole country. Those large variations can give the opportunity, when the energy needs are low, to that area to be a significant energy supplier to the main grid.

In order to make the creation of a green area feasible, the geological morphology, marine and weather conditions should be examined, since those factors are going to determine the kind and the quantity of the converting methods. Those methods should meet as many as possible of the energy demands, but always with respect to the environment, since there is the potential to alter it and affect the flora and fauna.

Today, in every project key words, except from efficiency, are availability and reliability. The combination of RES is required to be efficient, available continuously, reliable and to provide the desired energy balance, without interruption of operation other than for maintenance, because of the continuous needs for energy of any community. This makes the effort of creating a green area challenging.

Another aspect of examination is the economic feasibility of the project, in order to achieve a reasonable balance of initial and maintenance cost of the RES and fuel economy.

THIS PAGE INTENTIONALLY LEFT BLANK

## **II. RENEWABLE ENERGY SOURCES**

### **A. CATEGORIES**

From ancient times, it is well known to humankind that nature is an energy provider. There are many kinds of energy available and many ways to convert them to exploitable, or make them beneficial.

In Ancient Greece, the cities were planned and constructed, in such way, known as solar architecture, that every home could have equal access to winter sun. A solar-oriented house allowed the citizens to save heating fuel, charcoal at that time. In addition, there were efforts to convert wind energy to mechanical work, by creating windmills, while this energy was the major propulsion on ships.

The available energy sources, found in nature, are the wind, solar, geothermal, tidal and wave energy, while there is also energy in biomass and earthquakes. Although there are so many, the difficult task is the conversion to electricity and the efficiency of the converting systems.

#### **1. Solar Energy**

The sun with solar radiation is deriving the solar energy. Other than heating and cooling with solar architecture, solar hot water and daylight, there are solar powered electrical generation techniques as photovoltaics. The mechanisms that capture, convert and distribute this energy are divided in passive solar and active solar. Examples of active solar techniques are the photovoltaic or solar panels, which convert the energy into electricity and passive solar, are orienting a building to the sun and designing spaces that naturally circulate [1].

Today, the technology of designing photovoltaic panels is developing in a fast pace and growing rapidly. Solar panels are now more efficient, transportable and even flexible, making them capable for many applications and installations. A single solar cell does not provide enough power, but a combination of many in arrays make them able for powering medium sized applications [2].



Figure 1. Photovoltaic Solar Panels

## 2. Wind Power

The various ways to convert wind energy of the air flow to other useful form of energy, such as wind turbines to produce electricity, windmills to make mechanical work, windpumps for pumping water or sails to propel ships [1].

The biggest interest nowadays is the installation of wind turbines in large wind farms onshore and/or offshore. The numerous installed turbines will have the potential to produce enough electricity and supply a local transmitting system for medium communities/loads and isolated areas [1][2].



Figure 2. Iderdrola's Scopies Onshore Wind Farm in Greece



Figure 3. Offshore Wind Farm

### 3. Wave Power

A form of energy, which is met at seas, is the wave power. Surface waves are the mean of transporting energy and this energy can be used in the production of electricity and desalinate water. The higher the waves are, the more energy they transport, making the application of techniques for energy conversion more interesting. The installations can be onshore or offshore, depending on the morphology of the shores and the typical waves of the area [2].



Figure 4. Offshore Pelamis Wave Energy Converter. From [3]



Figure 5. Onshore LIMPET Wave Energy Converter. From [3]

#### 4. Tidal Power

The systems Earth-Moon, Earth-Sun and their gravitational forces are responsible for the recurrent change of the sea level, known as tide. The tide has different potential from area to area and in some cases is so strong that can create streams or elevate the sea level several meters.

The kinetic energy carried from the streams and the potential energy of the elevated mass of seawater can be converted by the suitable system to electricity. In the first case, the popular mechanism is underwater stream generators similar to wind turbines and in the second, large tank near the highest level store the water, which then following the principles of hydroelectricity produce electricity [2].

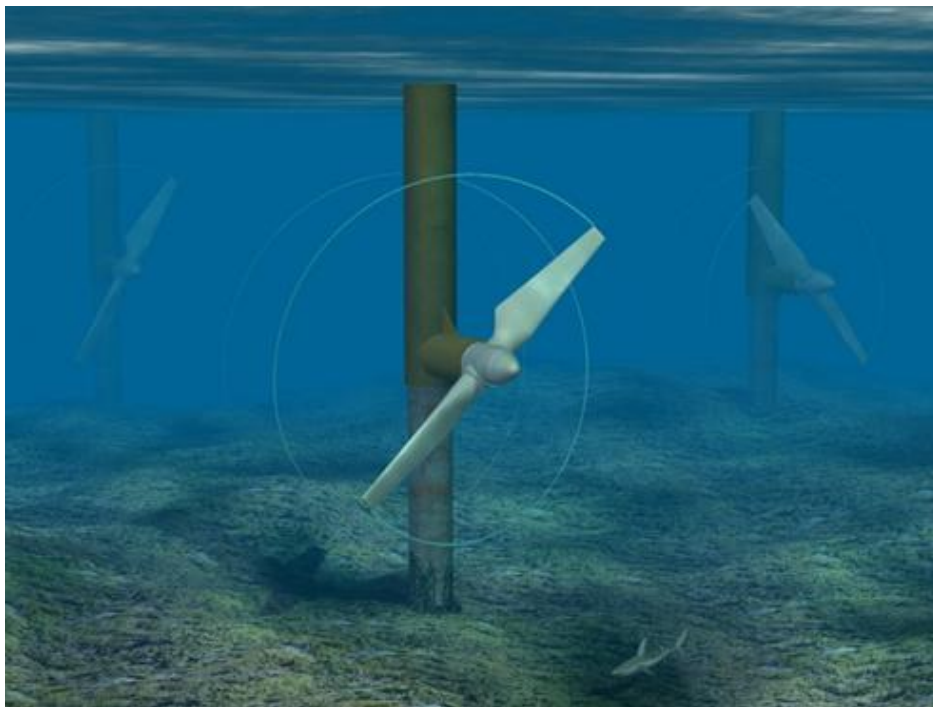

Figure 6. Under Water Stream Turbine



Figure 7. La Rance Tidal Power Plant in Brittany, France

## 5. Geothermal Energy

As a capacitor store energy in an electric circuit, the ground stores thermal energy originated from the creation of the planet and the natural decay of the minerals.[1] In Ancient Rome, this energy was used for space heating and bathing. Today, there small applications as a geothermal heating pump for a residential unit and large as geothermal power plants for energy production [2].



Figure 8. Part of Installation of a Geothermal Heating Pump



Figure 9. Geothermal Power Plant in Iceland

## 6. Biomass and Biofuels

The natural process of photosynthesis allows plants to capture energy from the sun. When the plants are burnt, they release the sun's energy they

contain. In this way, biomass functions as a sort of natural battery for storing solar energy. The plants that are produced and the dead ones, which it is planned to burn, are called biomass [1].

The products of various methods applied on biomass, like fermenting and transesterification, consist also an energy source. Those products known as biofuels, can be solids, liquids or gaseous. The liquid biofuels, such as biodiesel and bioethanol, are used as alternative fuels for vehicles, while the gaseous can replace natural gas [1].



Figure 10. Biomass Power Plant

## 7. Earthquakes

One of the most dense energy sources in nature are earthquakes. When a medium earthquake occur, the energy which is released can equivalent to the energy released by few to a few thousands metric tons of TNT. There are potential methods to harness the seismic wave, but since there is no accurate prediction of the earthquake characteristics, those methods have applied only in laboratories.

## **8. Hydrogen Fuel Cells**

Another more advanced form of renewable energy source is the combination of fuel cells combined with electrolyzers. When the energy produced by RES is more than the needs, can be supplied to the main grid or feed electrolyzers. The electrolyzers produce H<sub>2</sub> which is stored in an H<sub>2</sub> tank. In the cases when the produced energy is not enough, fuel cells can use the stored H<sub>2</sub> with O<sub>2</sub> from the air, and produce electricity and water, through inverse electrolysis. This is a free of charge, other than installation and maintenance costs, since the fuel is produces by the system. The cost of installation is high and there are no big facilities deployed, but this situation may change in the future.

### **B. ADVANTAGES**

The major advantages of RES are that they are free, they can be found almost everywhere and since they are renewable, they are endless and inexhaustible.

It is a fact that renewable energy facilities require less maintenance than conventional facilities. Their fuel is free and thus their cost of operation is lower.

The technology, used in those facilities, continuously evolves and new methods are introduced not only improving its efficiency, but also creating new scientific fields. To this also contributes the fact that since the weather is unpredictable, methods of energy storage are also improved.

Moreover, the projects usually are located away from the urban centers and large cities, giving the potential of economy rise of regional areas. The economic benefits can be local services and even tourism.

In areas with various sources, the combination of all available energies can be sufficient enough to cover the energy need of large loads, as industries or even medium sized communities.

Finally yet importantly, the renewable energy facilities produce little or no waste, such as emissions of carbon dioxide. It is obvious that those facilities have almost no impact to the environment.

### **C. DISADVANTAGES**

The renewable energy sources are not dense as the conventional sources. Thus, it is not a trivial problem to generate the desired electricity. They need much area for the facilities, which is not always feasible. While the loads multiple and require more energy it is imperative to build more and more facilities, which also affect and the conventional facilities.

The methods of converting the RES are not yet as efficient as the conventional production. In order to overcome the lower efficiency, more facilities with more installed machinery must be created.

The unpredictable of weather, although introduce and improve energy storage methods, increase the initial installation and maintenance cost and decrease the reliability and availability of the projects.

Finally, the inconsistency of power generation imposes the presence of conventional generation to cover the load needs, when there is lack of RES and the energy storages are close to empty.

### III. COMMUNITY ORGANIZATION

Most people, trying to make their life easier, faster and more convenient, began to use innovations and machines almost for everything. Now, the way of living is interwoven with energy consuming machines and their continuous usage in every aspect of life, while individuals started to consume more and more goods, just to fulfill their virtual needs. This resulted in the demand for more energy, in order to keep the machines working and to produce massive quantities of goods.

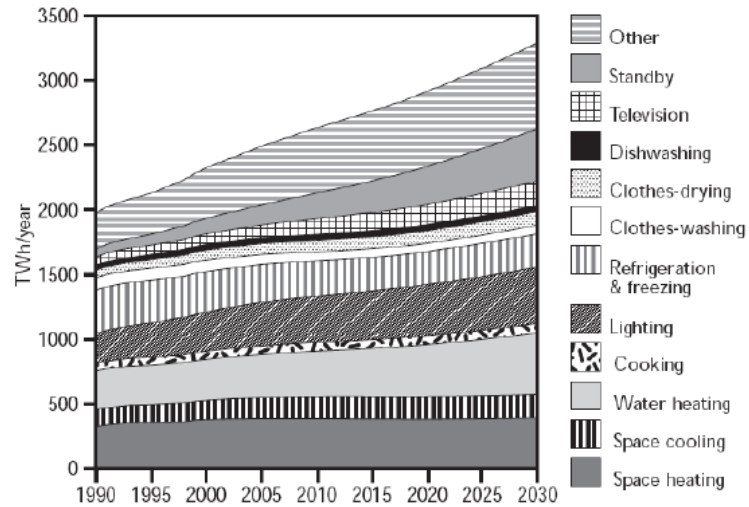

Figure 11. Projected Residential Electricity Consumption. From [7]

Today in the nature, the consequences of the overconsumption of energy and goods are obvious. The emissions of CO<sub>2</sub> change the climate and the atmosphere become similar to that of a greenhouse. The global temperature began to rise, affecting the balance of the weather and of living forms. Weather extremities are increasingly more often. The wastes of humankind polluted the soil, the water and the air.

Although lately, there are more intense actions by governments and communities to decrease the waste and the emission, still there are energy losses, since each individual is consuming more energy than its needs.

## **A. ENERGY LOSSES**

### **1. Emissions**

Since human needs increase the necessity of production of more energy, the power plants to cover those needs have to burn more fuel. The usual fuels are charcoal, fossil fuels and lignite. The products of combustion include gases, which are mainly greenhouse, like carbon dioxide, water vapor and nitrous oxide. As the production increases, the concentration of greenhouse gases in the atmosphere rises and changes its properties.

One of the inventions that changed the way of living is the vehicles. The mass production and use of vehicles improved the quality of live. On the contrary, vehicles use fuel, of which the combustion products are also greenhouse products. Moreover, their thoughtless use for any transportation contributed to the air pollution.

### **2. Wastes**

The virtual needs of modern man led him to buy more goods than he actually needs. Industries, in order to cover those needs and to have increased profits, started to introduce to their production lines new cheaper materials, which natural mechanisms cannot easily decompose.

The overconsumption has as results the increased quantities of organic and inorganic wastes, which until recently were just thrown away. That way, the raw materials were spent quickly and industries had to come up with new alternative artificial materials.

### **3. Heat Losses**

Another energy loss, which is not so obvious, but yet is equally important as the previous, comes from heat. A house with no proper design cannot remain cool during summer and warm during winter. As a consequence, more energy is need to sustain it in low temperature and more fuel for higher temperature. This

energy loss increases the electrical loads during summer and increases the fuel consumption during winter. In both cases again, the greenhouse emissions are more than usual.

## **B. RETRIEVAL METHODS**

There are many methods introduced to decrease or even minimize the energy losses of a community. It is imperative though, that not only major industries have to apply the specifications of governments, but also small companies and even more individuals have to be consistent to the ecological actions.

### **1. Emissions**

The creation of RES farm, where the weather conditions are ideal, has the potential to produce enough energy to supply large enough loads. The emissions of those farms are minimum and replace the polluting conventional power plants. The power plants will become the backup safety for the energy grid, but have also to minimize their emissions and increase even more the efficiency, by using the heat from the exhaust, to heat water for internal or for public use.

Almost every automobile company has constructed a green vehicle, hybrid, electrical or for alternative green fuels. As technology improves, more powerful engines can be designed and replace the engines of large commercial vehicles. Governments can encourage citizens to buy those cars, providing them with more benefits, and permit only these to circulate in big cities or in areas that are designated as green. Green can also be boats.



Figure 12. Electric City Car. From [3]

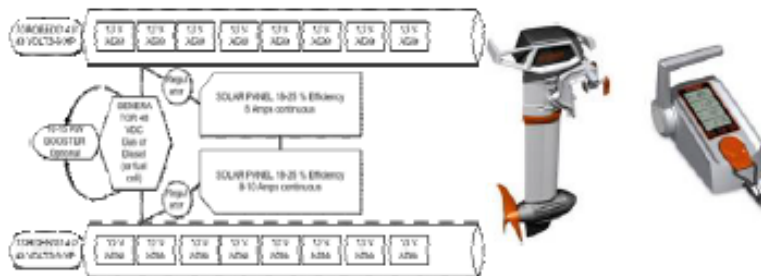

Figure 13. Electric Boat. From [3]

## 2. Wastes

Recycling should become a way of life for every individual. Every waste deposit should have potential to collect and categorize the incoming material. The recyclable should be remanufactured and reused, while the non-recyclable can be buried. The burial must be done in such way that the produced gases from decomposition of organic material can be collected. Gases, like hydrogen and methane, can be used as fuel for generators or as biogas.

Additionally, every house, complex and companies could have their own composter to produce fertilizer for the community needs. The benefits composting are less wastes, less plastic garbage bags and less total costs.



Figure 14. Composter

Finally yet importantly, wastewater treatments should be installed close to major cities and groups of small communities. Nothing will end at the sea or at the water table and the useful products of the treatment are going to be used in agriculture.



Figure 15. Wastewater Treatment in Psytalia Island, Greece

### 3. Heat Losses

Like ancient times, houses should be design and constructed in such manner, that will take advantage of the sun's heat during winters and have physical air circulation during summers. The use of insulating materials is imperative to avoid further heat losses.

More applications are available, like the fireplace furnaces, which use the energy of fire to heat the air and distribute it around the house.



Figure 16. Fireplace Furnace

#### **IV. AREA-TERRITORIAL EXAMINATION**

A temperate climate characterizes Greece with mild wet winters and hot dry summers. The temperatures are rarely excessive and snow is a phenomenon at large altitudes. Greece is located between the 34 and the 42 parallel of the Northern Hemisphere, has plenty of sunshine nearly all year round and a great variety of climate types. This variety is caused by the topographic configuration and large altitude differences, as there are mountain ranges along the central part and other mountainous areas and the alternation of land and sea.

This study is going to examine particularly the Salamis Island, which is located near to the capital city of Greece, Athens. It has a population of 39,220, an area of 95 square kilometers and is the island with the highest permanent population density in Greece. The high population density is due to the short distance from Athens (16 kilometers) and Piraeus (1 nautical mile). The short distance from those cities makes Salamis very popular for holiday and weekend visits. During the summer, the population of Salamis noted a huge increase, and estimated close to 300,000. There are four communities in Salamis, named Salamis, Ampelakia, Aianteio and Selinia. The biggest of them is Salamis and the smallest Selinia.

The occupations of the majority of the inhabitants are maritime, fishing, ferries, and the island's shipyards. There are also agricultural occupations in the inland, but the work force is significantly less in number. Although Salamis does not have any heavy industry, the dockyards and the naval base on the northeast coast are the two larger energy consumers. During summertime, the strong service industry sector is added to the loads of the island.



Figure 17. Geographical Location of Salamis Island and Athens.

The electrical energy supply is consists of a single connection with the main continental grid, while there is no energy source, natural gas or oil supply pipes installed in the island making the island ideal for the installation of RES.

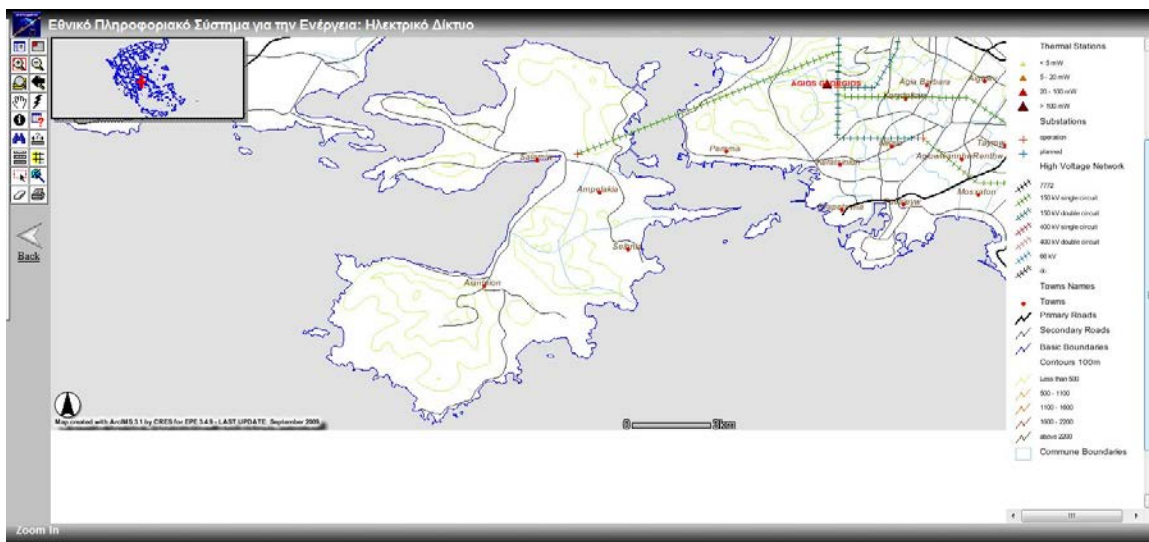

Figure 18. Electrical Supply System of Salamis. From [4]

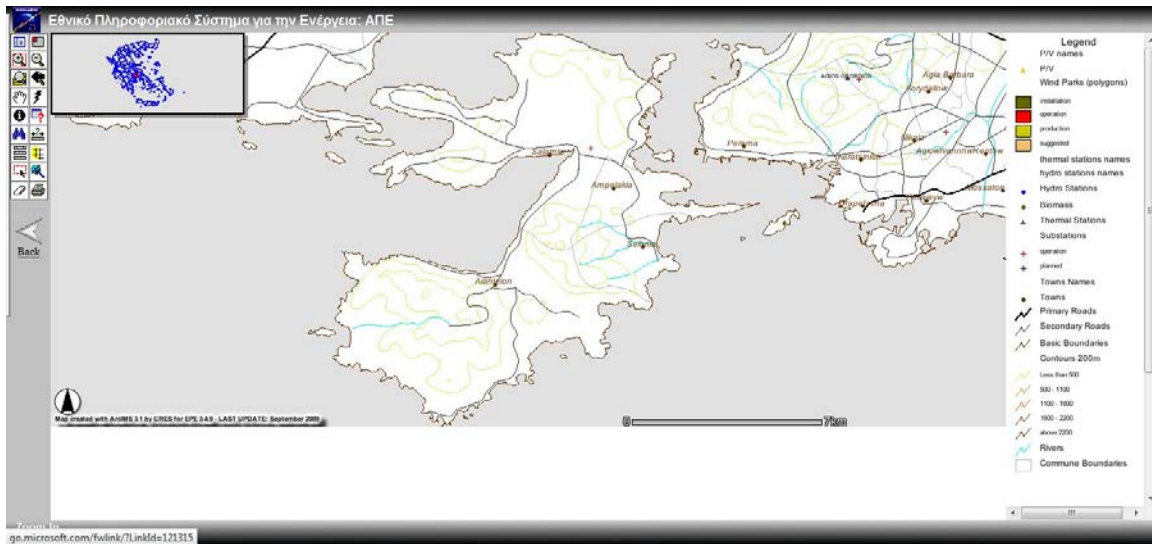

Figure 19. Installed Energy Sources in Salmis. From [4]

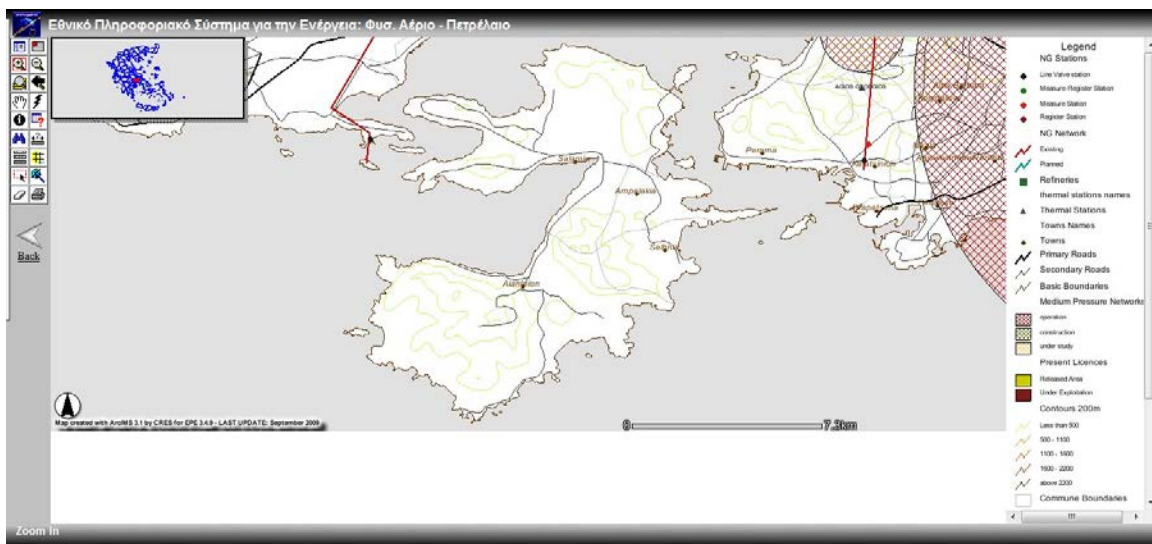

Figure 20. Natural Gas and Oil Distribution System in Salmis. From [4]

## A. MORPHOLOGY

Salmis has an area of 36 square miles and its highest point is Mavrovouni (1325 feet or 404 meters). Most part of the island is rocky and mountainous, while on the southern part of the island; a pine forest is located, which is unusual for western Attica.

The population of Salamis is gathered in the cities of the island, while small villages and few houses are scattered along the inland and coasts.

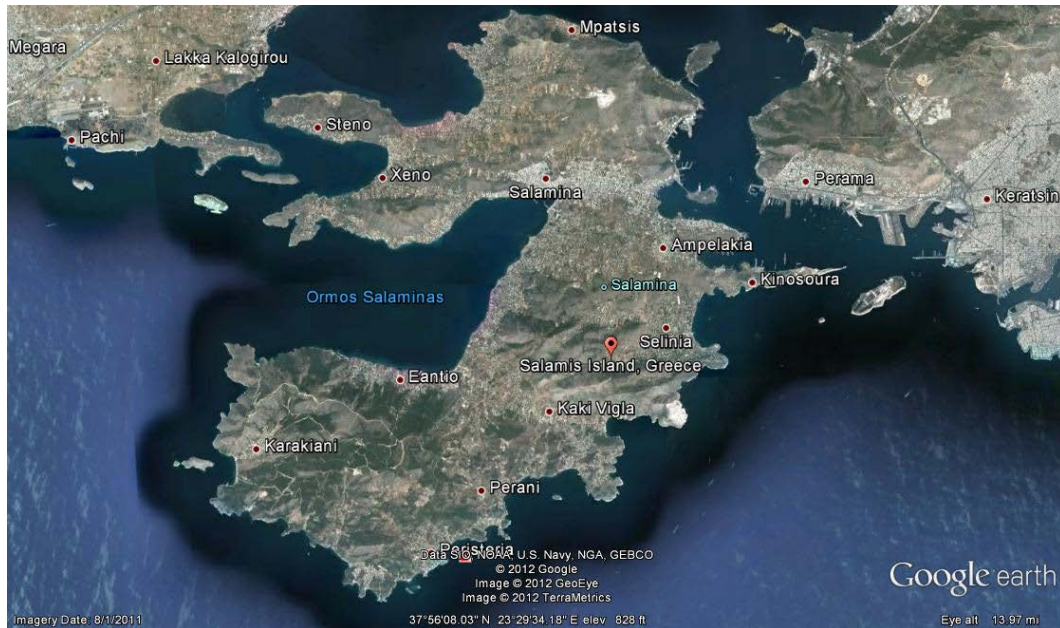

Figure 21. Satellite View of Salamis

## B. CLIMATE

The climate is temperate, Mediterranean and generally mild most of the time. Although it is Mediterranean, there are large differences in the ranges of temperature between summer and winter than in other parts of the country. The average annual temperature is about 18.3°C. There are few times when the temperature exceeds 40°C. In the winter, the temperature can fall even below zero. Warmest month is July and the coldest is January. In November, the cold becomes to be felt, but the snow usually starts after the last week of November. The winter snowfalls are not too common, but whenever they occur, usually snow melts within a few hours. Athens and the around areas, including Salamis, is famous for its very hot and sunny summers. The rest of the year rainfall is rare.

Month	Avg. Max. Temp (°C)	Avg. Min. Temp (°C)	Avg. Temp (°C)	Max. Temp (°C)	Min. Temp (°C)	Wind Speed (m/s)
Jan	13	5.5	9.25	18.8	-0.1	11.3
Feb	13.8	6.5	10.15	18.6	-0.4	9.7
Mar	16.7	8.6	12.65	22	3	8.8
Apr	20	11.6	15.8	25	6.1	8.6
May	25.2	15.7	20.45	30.7	11	7.6
Jun	30.4	20.5	25.45	36.6	15.7	9.4
Jul	30.4	20.5	25.45	36.6	15.7	9.4
Aug	33.6	23.7	28.65	37.8	21.3	11.1
Sep	28.7	19.7	24.2	33.6	14.8	8.9
Oct	23.4	15.6	19.5	28.1	9.3	8.2
Nov	18.7	11.5	15.1	23.3	5.9	9.4
Dec	14.6	8.4	11.5	19.7	1.5	9

Table 1. Mean Temperature and Wind Values the Last 10 Years

### C. ENERGY NEEDS

The energy needs of Salamis are quite complicated. Therefore, the loads are not steady and vary not in a usual manner as in other cases.

#### 1. Community Needs

Although many of the houses are not occupied all year long, those houses become residence of almost eight times more citizens during summer. Taking into consideration the high temperatures during summertime, it is easily realized that there an impressive rise of energy loads and energy consumption.

Salamis has a variety of houses, built in different periods. The construction materials differ in those periods and the architectonic designs. The older houses were built with cheap materials, whose insulating properties were pure. Most of the new houses are built in accordance to thermal insulation using materials with better quality and properties. Since the older houses are more in number, the energy needs of them are increased, based also to fact that the energy losses of them in heating and cooling are increased.

Community	Hot Water (MJ)	Heating (MJ)			
		Houses Built Before 1970	Houses Built 1970-1985	Houses Built 1985-1995	Houses Built After 1995
<b>Salamina</b>	27,584,067.00	135,392,245.20	125,190,464.40	26,530,920.00	7,289,053.20
<b>Aianteio</b>	4,909,195.00	13,480,023.60	27,147,189.60	5,639,223.60	1,817,467.20
<b>Ampelakia</b>	5,024,534.00	33,252,721.20	23,432,947.20	4,753,008.00	1,039,813.20
<b>Selinia</b>	2,469,954.00	10,186,110.00	12,720,157.20	2,951,157.60	1,072,476.00
<b>Total</b>	39,987,750.00	192,311,100.00	188,490,758.40	39,874,309.20	11,218,809.60
<b>Overall Total</b>	<b>471,882,727.20</b>				

Table 2. Annual Energy Needs of Salamis. From [4]

## 2. Naval Base Needs

The naval base facilities on the northeastern coast of Salamis impose an unsteady load on the grid.

Depending on the number of ships in port, the energy needs change, both for the ships and for the workshops on shore. During drills, most of the ships are underway and the only varying load of the base is that of the workshop. The ships, which do not participate in the drill, can be considered as constant loads.

In the mornings, although most of the personnel are doing maintenance work, for the safety of the equipment, the ships generators provide the power. At the same time, the working shops in the base facilities are consuming power to repair the defected equipment and machinery of the ships. In the afternoon, the repairs done in the workshops stop, except from emergency repairs, and the power consumption is minimum. In addition, the maintenance work on the ship also stops, but in contrast, now the shore electrical system provides the power to the vital systems of her, in order to minimize the fuel consumption, emissions and future maintenance costs.

## D. RENEWABLE ENERGY SOURCES POTENTIAL

Since this study has as target the exclusive supply of power from RES, it is mandatory to examine the RES potential at the Salamis Island. In addition, the areas where the potential is high must be taken into consideration, in order to see if the available space is enough for installations.

### 1. Wind Power

The most significant characteristic speeds of wind turbines is the cut-in and the cut-out speed. The first speed is the minimum speed that a wind turbine starts to produce power, while the second is the maximum speed that a wind turbine can operate with safety. For most wind turbines, the cut-in speed is between 3–4.5 m/s and the cut-out is between 20–36 m/s. Therefore, at the area we must have at least wind speed of the order of 3 m/s to generate power.

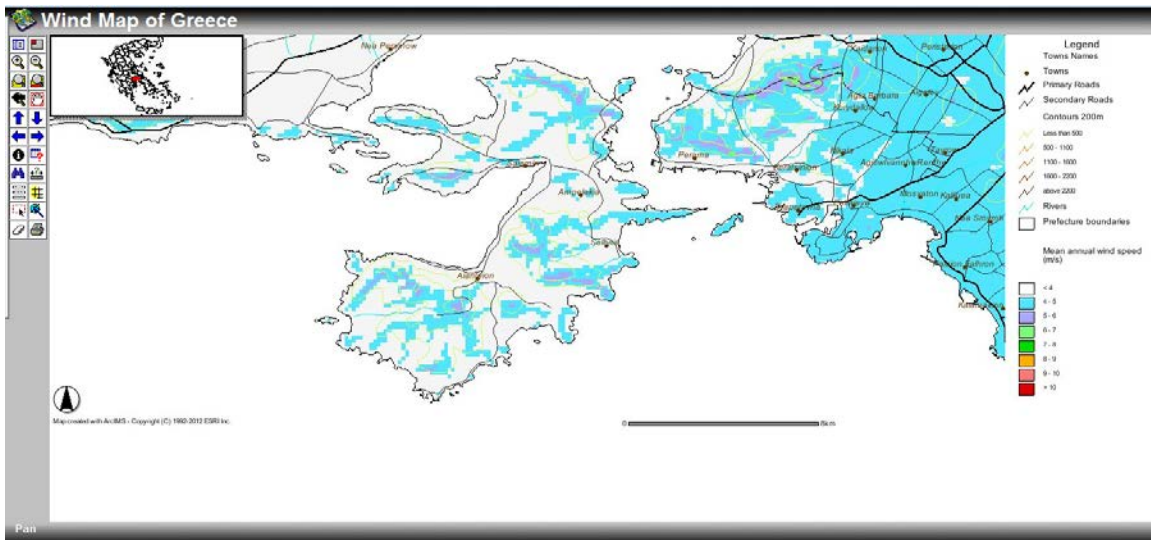

Figure 22. Wind Potential of Salamis. From [4]

### 2. Solar Power

The plenty sunshine, which characterizes Greece and by extension Salamis, is ideal for the use of photovoltaic solar panels (PVP) to generate

power. It must be noted though, that as temperature increases, the efficiency of PVPs decreases. In contrast with wind turbines, there are three ways of installing PVPs, which affect the power generation.

The first way is installing PVPs in a horizontal plane, usually on the roofs of buildings. This is the easier installation, but the efficiency of PVPs is not optimum.

The second way is installing them with the proper orientation, so that the power generation would be optimum. For the north hemisphere, the optimal orientation for the installation of photovoltaic systems is the south and at an angle, less than by  $20^\circ$  of the latitude of the region, with almost 100% efficiency, since the PVP is under direct radiation. In the case of Salamis, the latitude is  $38^\circ$  and so the optimal placement is about  $18^\circ$  relative to the horizontal plane. Such placement is often difficult to achieve, when it comes to installing systems in existing buildings, which have a specific orientation. If there is an opportunity for south facing, a  $45^\circ$  deviation from the south, southeast or northwest, efficiency reaches 95%. The horizontal placement does not depend on the orientation and performance is about 90%, being efficient in the utilization of indirect radiation. The installation of photovoltaic systems in slope at the eastern or western orientation can have up to 85% efficiency, and as directed to the north does not exceed 60%. Finally, the vertical installation efficiency is ranging from 20% facing north to 70% south, compared to the optimal orientation

The last way of installation has the best efficiency all day long. That is happening, because there are mechanisms that change the orientation of the PVP and keeping it always perpendicular to the Sun's radiation.

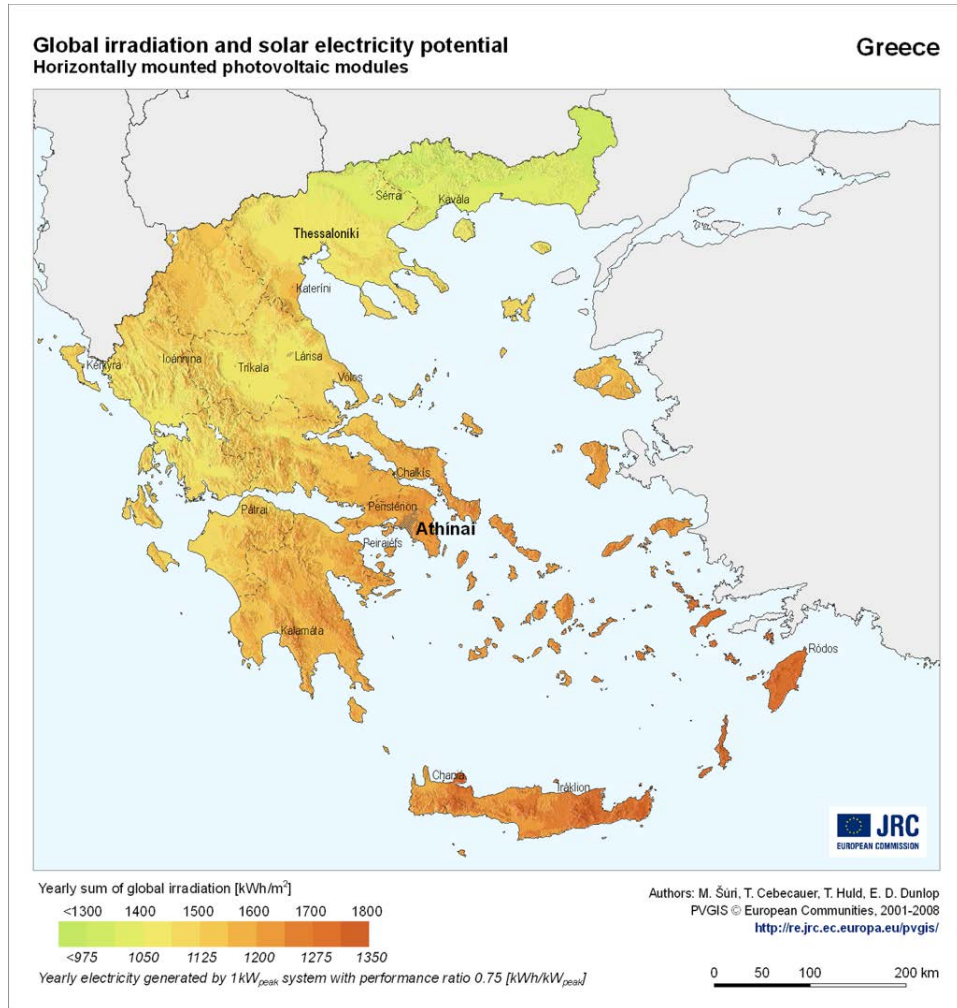

Figure 23. Photovoltaic Potential of Horizontally Mounted Modules. From [5]

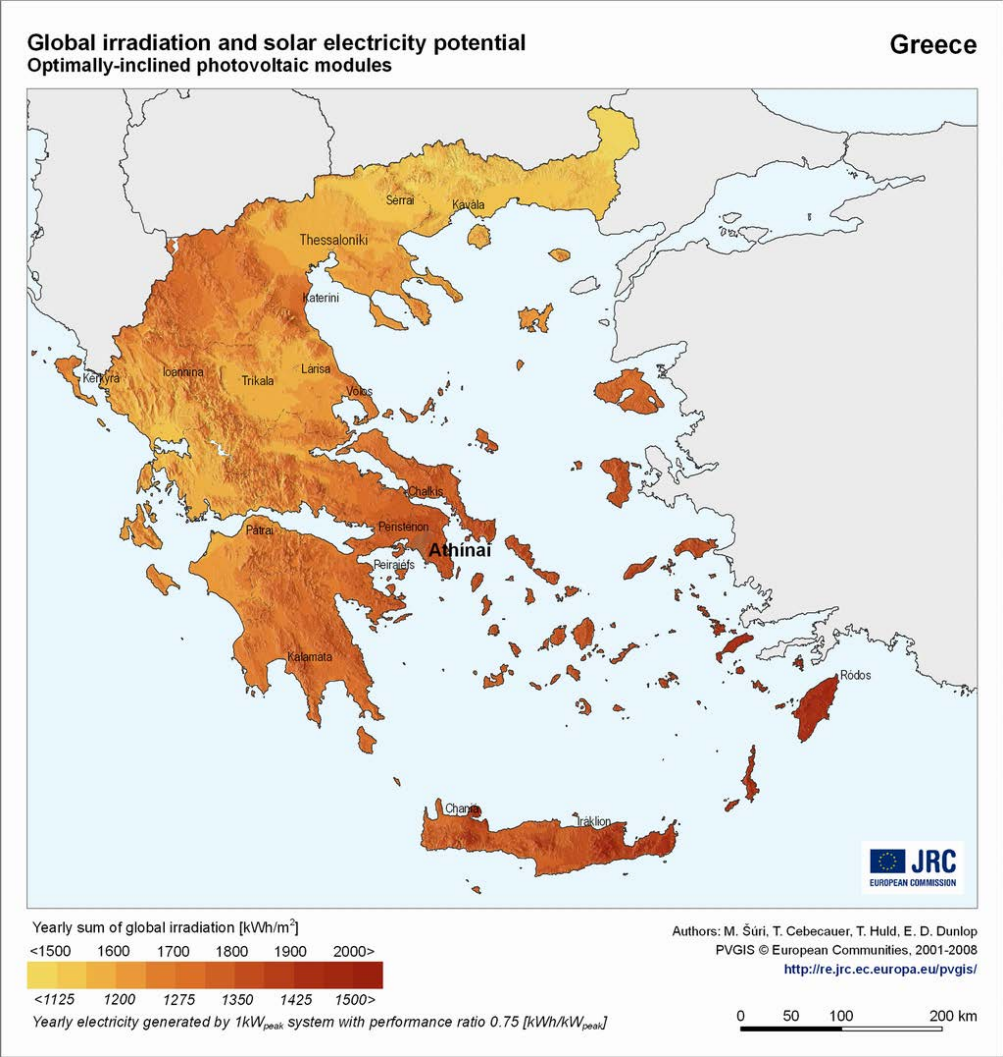

Figure 24. Photovoltaic Potential of Optimally Mounted Modules. From [5]

**3. Geothermal Power**

Same as in case of solar power, the sunshine increases the potential of geothermal power. The geological conditions of Salamis offer a promising potential for geothermal utilization of its subsurface matter. Although, the main use of geothermal energy is the direct use of its heat in greenhouse or houses, sufficiently high enthalpies are present to give the ability to take advantage of the geothermal potential indirectly to produce electricity.

#### 4. Wave Power

Although at the area the more intense winds are north, the direction of the waves are from southeast. This is happening due to the geography of Salamis. The entrance of the Saronic Gulf has south orientation, which is then followed a relatively large fetch from south to north, favoring the entry and ongoing of waves from the open sea of the Aegean Sea. For the same reason any strong marine conditions, as the prevailing waves, are coming from southern directions.

The southeastern sea area of Salamis is ideal for mooring of commercial ships, depending on the weather conditions. Due the coastal the sea bottom morphology, there are many alternative areas for mooring, living the southeastern region free for installing of offshore wave energy converters.

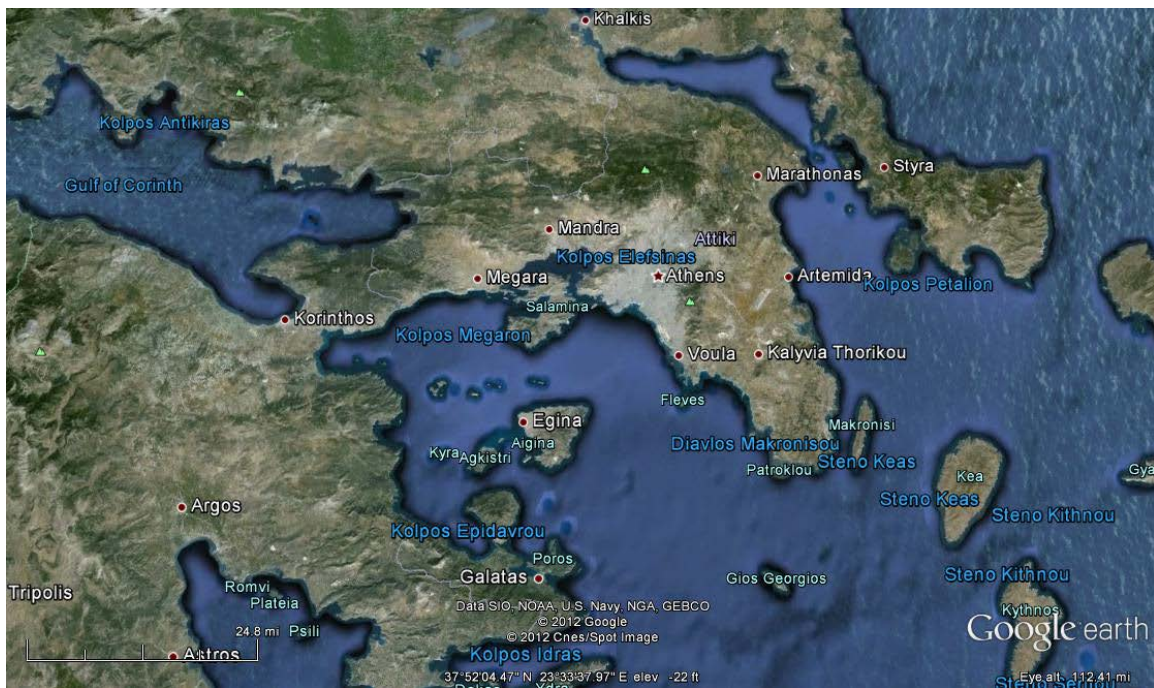

Figure 25. Geographic Overview of Salamis and Saronic Gulf

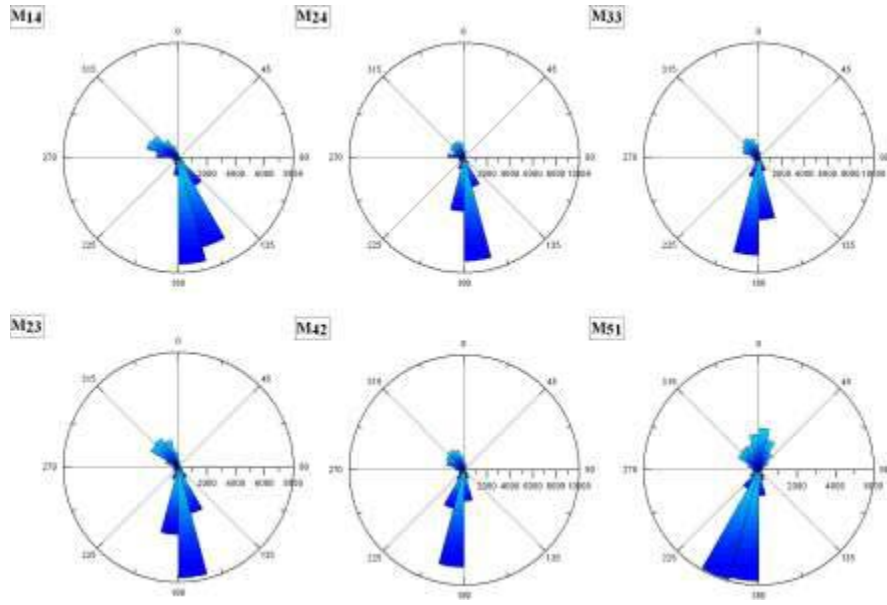

Figure 26. Directional Intensity Diagrams of Waves at the Entrance of Saronic Gulf. From [6]

## 5. Tidal Power

Salamis does not have the potential for tidal power, since the biggest tide that it has been observed is about one meter.

## 6. Biomass and Biofuels

The rocky and mountainous morphology of Salamis limits the potential of producing enough biomass. Also, the fact that is the island with the greatest population density constrain the fields of the island.

## **V. OPTIMIZATION**

The creation of a hybrid energy supply system with RES has many advantages over a traditional single source system. The combination of many RES makes the optimization of the system more complex, due to the variation of energy production of RES, in combination with energy demands. In the traditional system the energy production is linear, while on the other hand, RES have non-linear behavior. The many components insert to the problem many variables and render system optimization difficult. Since there are many variables, many different solutions are feasible for any given hybrid system with respect to the variable that is desired to be optimized. An overall optimization of a hybrid system, based on traditional mathematics, is too hard.

The interest of countries in RES and their actions of converting areas into green led the creation of software for RES optimization. There are many software programs that have the capability of technical, economic and optimization analysis, which can combine multiple energy sources of different kind and also store the energy for future use.

### **A. OPTIMIZATION PROGRAMS**

#### **1. HOGA [8]**

HOGA is a RES optimization program created and developed by the University of Saragossa in Spain and it stands for Hybrid Optimization by Generic Algorithms. It is developed in C++ to optimize hybrid renewable system for generation of electrical energy, DC and/or AC, and/or hydrogen.

The optimization process is done in financial or technical way. The total system cost throughout the whole of its useful lifespan and/or the equivalent CO<sub>2</sub> emissions, as selected by the user, can be minimized. Since those variables are mutually counterproductive in many cases, more than one optimum combination is offered, for a multi-variable problem. According to the importance of each variable, different solutions show better performance for different objectives.

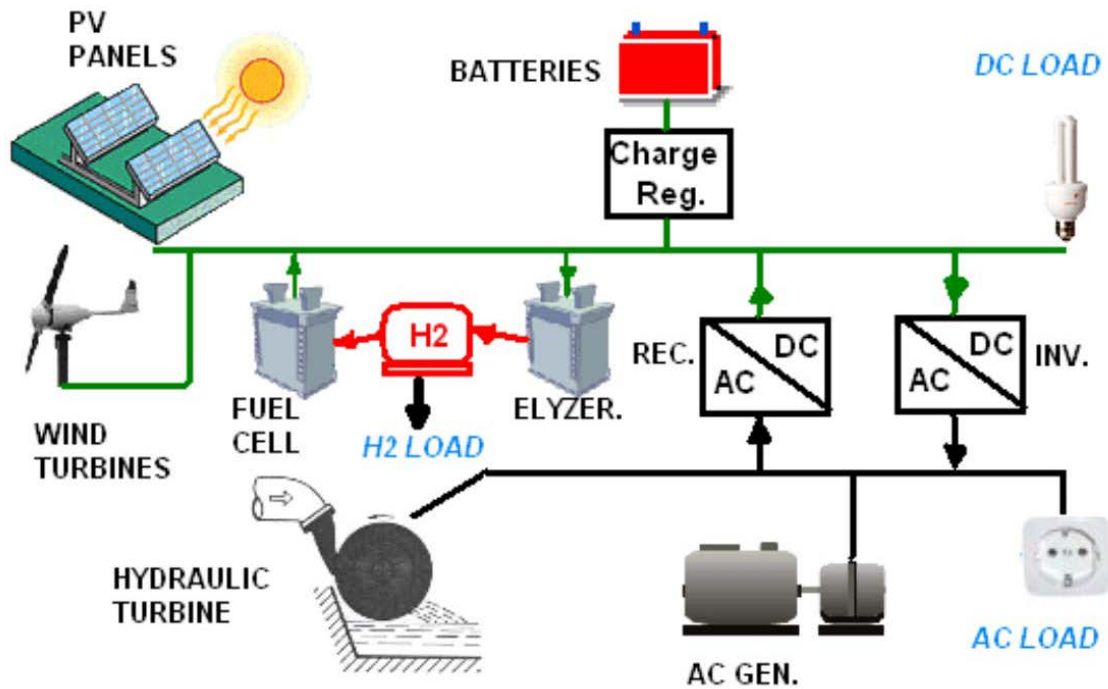

Figure 27. Elements for a Generic Case in HOGA

The system under examination can have as sources:

- Photovoltaic panels
- Wind turbines
- Hydraulic turbines
- Fuel cells
- H<sub>2</sub> tanks
- Batteries
- AC generators

The loads can be:

- Electric AC loads
- Electric DC loads
- Electrolyzers
- Hydrogen loads
- Water pumping load

In order to have a completed system additional equipment is available:

- Battery charge regulators
- Inverters
- Rectifiers

The capabilities of the program allow the user to choose if wants to have the system connected to the grid, for surplus unused energy, or store energy for future use.

HOGA uses two generic algorithms, the first of the system components and the other for the control strategy and so, it offers the ability to evaluate all the possible combination of components and control variable strategies. Even if an optimum solution is not feasible, the algorithms calculate a near to optimum solution in short time.

## **2. HOMER [11]**

HOMER is an optimization program for hybrid systems created and developed by the National Renewable Energy Laboratory of U.S. Department of Energy. It simplifies the hybrid system in both on-grid and off-grid design and with that simplification and its optimization and sensitivity analysis provide many solutions for the system configurations.

The inputs that HOMER need are:

- Technology options
- Component costs
- Resource availability

HOMER with those inputs, simulating different system configurations and combination of components, generates possible solutions in a list of feasible configurations with respect to net preset cost. It has also the option to compare and evaluate different configurations on economic and technical merit.

The sensitivity analysis is performed to estimate how changes in factors, as resource availability and economic condition, can affect the cost-effectiveness

of different configurations. Through that analysis, it is easy to identify the variables that have the greatest impact to the design and operation of the hybrid system.

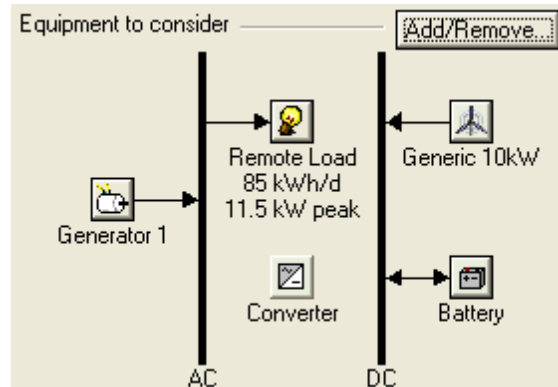

Figure 28. Sample of Sources and Loads of HOMER

HOMER can simulate the operation of the system for each hour in a year, comparing the demands and the power production, while it can provide information about using generators and charging or discharging the batteries of the system, based on the hourly energy balance. For each configuration, a simulation is performed and the program determines if it is feasible from technical and economic aspect. Economically, it calculates the cost of installation, maintenance, operation, replacement, fuel over the lifetime and the interest of the project.

### 3. Hybrid2 [10]

Hybrid2 is an optimization program for hybrid systems created and developed by the National Renewable Energy Laboratory of U.S. Department of Energy. It is programmed in Microsoft Visual Basic and uses a Microsoft Access Database. It consists of four parts:

- Graphical user interface
- Simulation module
- Economics module
- Graphical results interface

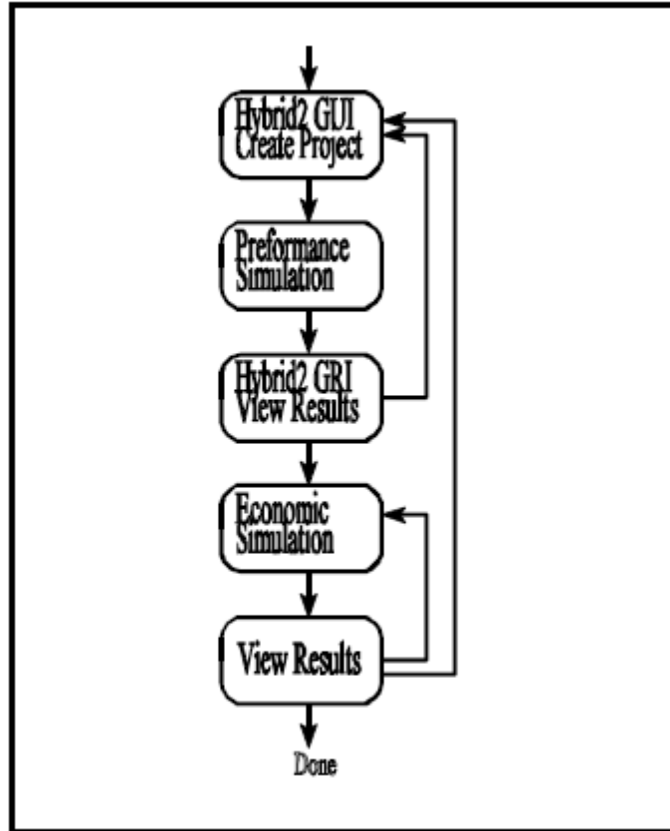

Figure 29. The Structure of Hybrid2

The users interface helps the user by containing a glossary of frequently used terms and definitions of all the program input parameters and has a library of projects, power systems, time series data and mechanical components. At the beginning of each simulation, an error checking of the input data is performed.

The simulation module is dealing with the simulation of different system architectures with varying loads and components, like wind turbines, photovoltaic arrays, batteries, converters and load on an AC and/or DC bus. The economic module is performing a financial analysis using the system performance information from the simulation module.

The graphical result interface is a user-friendly representation of the simulation and economic analysis data, in order to have a better evaluation of the results.

This program has been used in smaller applications, like the installation of a wind turbine on a ship [18].

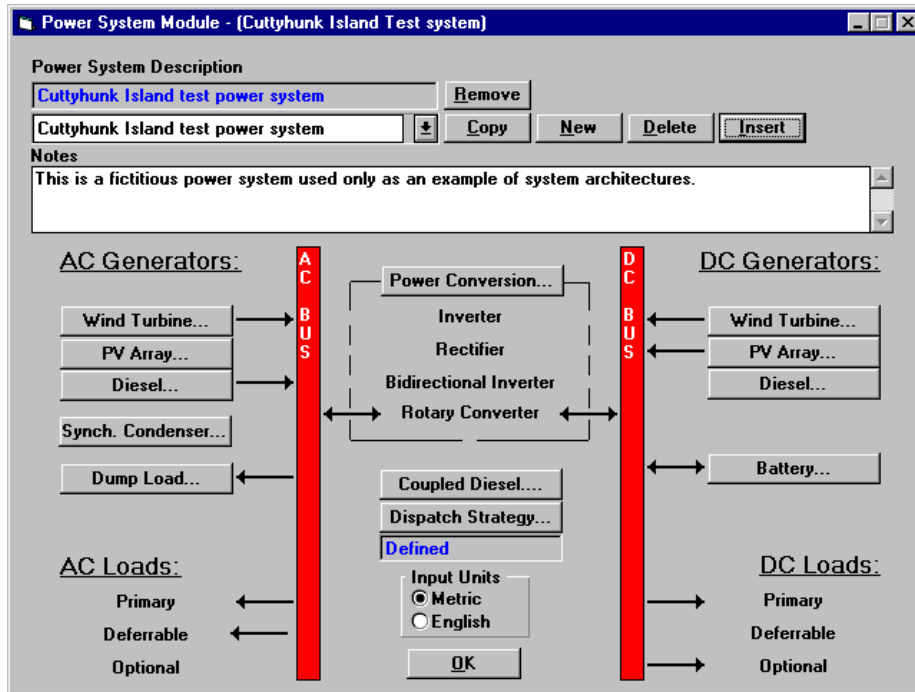

Figure 30. An Overview of a System in Hybrid2

#### 4. RETScreen [12]

The CANMET Energy Technology Centre - Varennes, develops RETScreen for the Ministry of Natural Resources Canada. RETScreen 4 is an excel-based clean energy project analysis software tool, that determines the technical and financial viability of potential renewable energy, energy efficiency and cogeneration projects. RETScreen Plus is a windows-based energy management software tool that verifies the ongoing energy performance of existing facilities, since it has also the ability to extract weather values, such as temperature, solar radiation and wind speed from the NASA databases for the last years. Both of them are programs of RETScreen Suite.

It can evaluate, in different places worldwide, the energy production, life and cycle costs and greenhouse gas emission reduction of various RES, using a standardized and integrated clean energy project analysis software

The simplified analysis perform quick calculations to find the simple payback of power production projects using only the power capacity, the capacity factor, the electricity export rate, and the initial and annual costs.

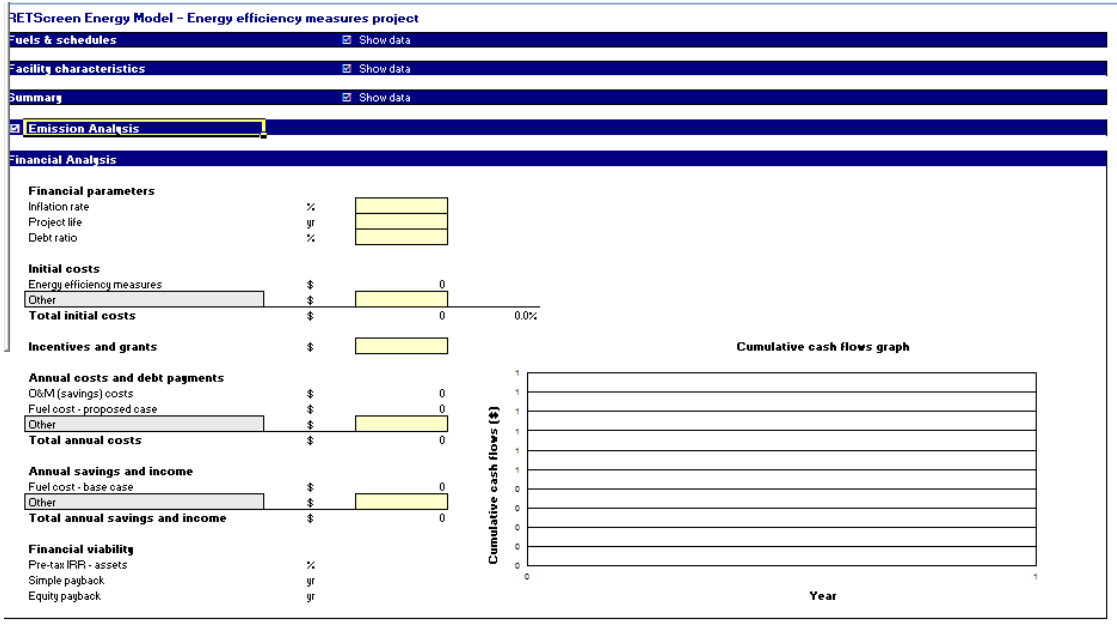

Figure 31. General View of RETScreen 4

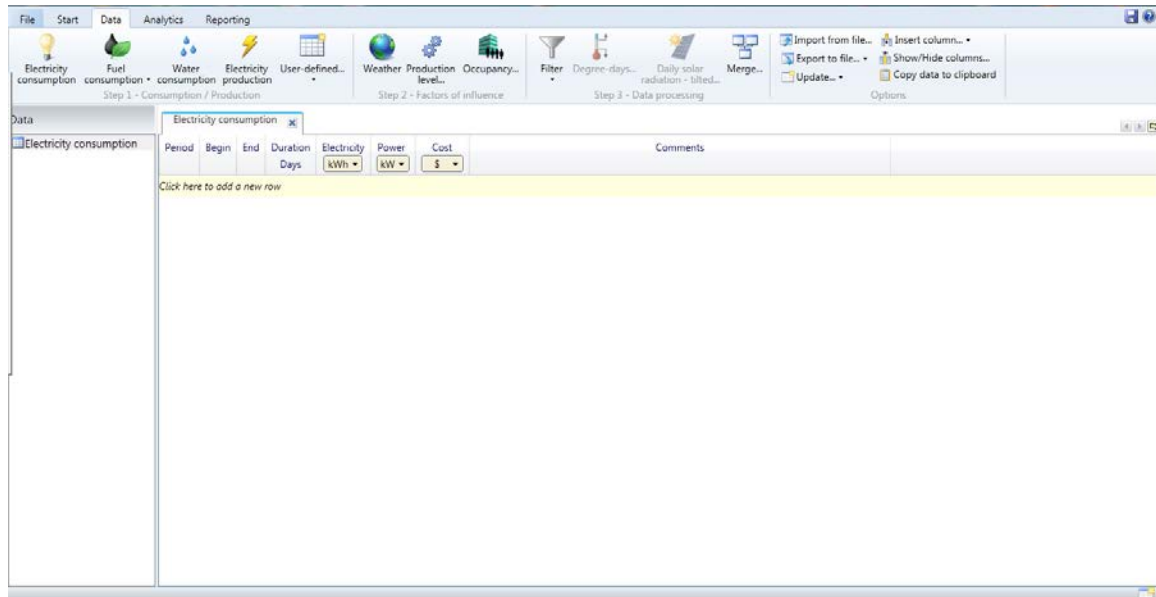

Figure 32. Overview of RETScreen Plus

## 5. ViPOR [13]

ViPOR is an optimization program for designing electrification systems of small communities developed by the National Renewable Energy Laboratory of U.S. Department of Energy. It has the ability to create an overall distribution power system, based on the sources, the loads and morphology of the terrain. The created grid is optimized with respect to the different cost of running wires over different terrains.

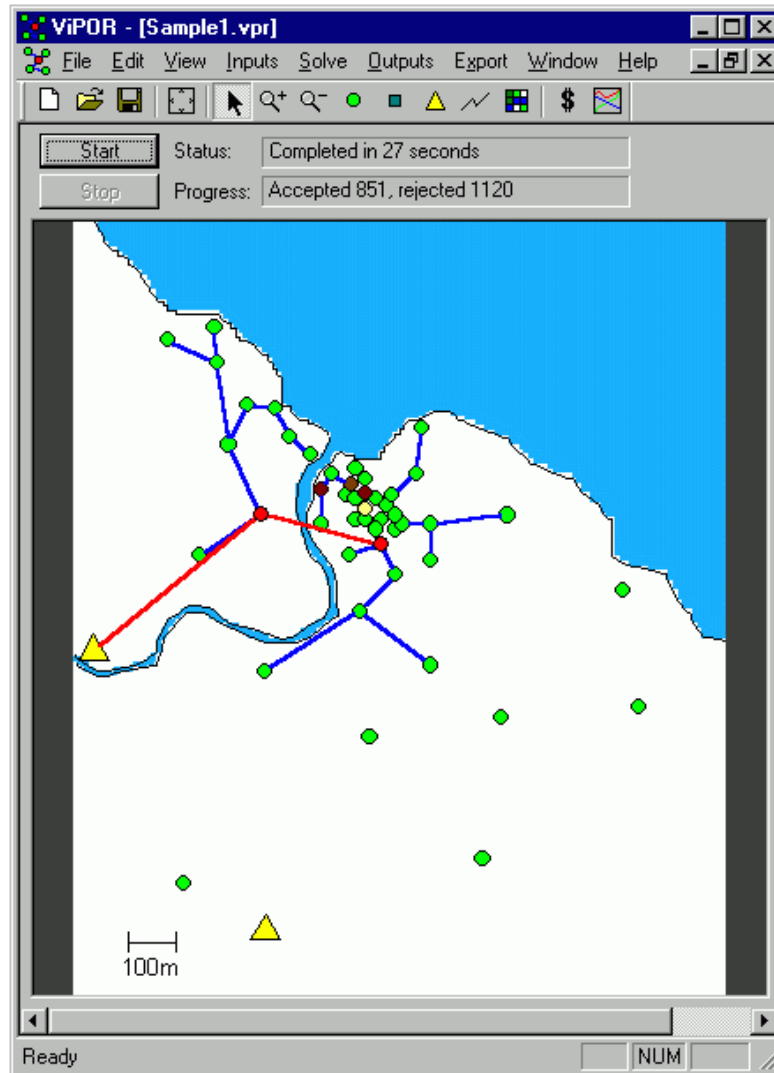

Figure 33. Sample of Results of ViPOR

## 6. Overall

Each program has advantages and disadvantages, according to the technologies that can simulate and the function it can perform. Therefore, in order to simulate, as best as it can be, an area it is better to combine the results of all programs.

Technology	Programs			
	HOMER	Hybrid2	HOGA	RETScreen
Hybrid Systems	X	X	X	
PVP	X	X	X	X
Diesel	X	X	X	
Batteries	X	X	X	X
Wind	X	X	X	X
Mini-Hydro	X	X	X	X
Fuel Cell, Electrolyzer and Hydrogen Tank	X	X	X	
Hydrogen Load	X	X	X	
Biomass	X		X	X
Thermal Load	X	X	X	
Heating Load				X
Control Strategies	X	X	X	
Simulation	X	X	X	
Economical Optimization	X		X	X
Technical Optimization		X		
Multi-Objective Optimization			X	
Sensitivity Analysis	X		X	

Table 3. Abilities of Optimization Programs

## B. DATA

The simulation programs have a large amount of data stored that can be used as default for the optimization analysis. The user has also the option to insert data to each program. This data is not just the energy demands of the area under examination, but it can also be the statistics of the RES, mean values or detailed over day hour, and the technical data of the equipment that is proposed for use. For a wind turbine, the possible inserted data can be every operating parameter like power output, characteristic velocities of operation and efficiency. The data inserted for the financial analysis is going to be the highest, since that way, any worst-case scenario is covered.

## 1. Residential Energy Needs

From Table 2, we have that total residential annual needs in Salamis are about 472TJ or 131GWh. Those energy needs are not equally distributed over the year. In addition, the population increases greatly during the summer. The obtained statistics for energy consumption of a medium age residence in Salamis is a four-member family. The calculations, in order to find the total monthly, are done based on the individual daily needs i.e., for January the calculations are:

$$DIC = \frac{DRC}{4} = \frac{15.17KWh}{4} = 3.7925KWh$$

$$TC_{\text{based on population}} = \text{Population} * \text{Days} * DIC = 40000 * 31 * 3.7925KWh = 4702.7MWh$$

$$TC = HLD * TC = 1.18 * 4702.7MWh = 5.549186GWh$$

Month	Daily Residential Consumption (KWh)	Daily Individual Consumption (KWh)	Total Consumption Based on Population (MWh)	House Losses Deviation (%)	Total Consumption (GWh)
Jan	15.17	3.7925	4702.7	18	5.549186
Feb	15.17	3.7925	4247.6	18	5.012168
Mar	12.82	3.205	3974.2	18	4.689556
Apr	12.82	3.205	3846	18	4.53828
May	11.95	2.9875	3704.5	18	4.37131
Jun	11.95	2.9875	26887.5	18	31.72725
Jul	10.21	2.5525	23738.25	18	28.011135
Aug	10.21	2.5525	23738.25	18	28.011135
Sep	11.26	2.815	3378	18	3.98604
Oct	11.26	2.815	3490.6	18	4.118908
Nov	15.31	3.8275	4593	18	5.41974
Dec	15.31	3.8275	4746.1	18	5.600398
<b>Total Annual Consumption</b>		38.36	111046.7		131.035106

Table 4. The Annual Energy Consumption of Residences in Salamis

## 2. Naval Base Needs

The naval base facilities in Salamis are complicated with respect to their energy demands and it is safer to consider the whole base as a constant load, since there is always a possibility for an unplanned mission or drill of one or a group of ships. The assumed load will be as if the base has the maximum needs,

even though this will maximize the initial cost of the project. This way, it is possible for the installed RES to produce an energy surplus over longer periods and be beneficial for the grid.

In order to calculate the daily, monthly and annually demands of the base, the calculation are done based on the following assumptions:

- All the ships are in port.
- All the ships are consuming energy from the shore grid without any break all year long.
- The workshops and the offices are working fully for eight hours in the morning and afternoon. For the rest of the day the energy demands are partial.

	Daily Consumption (MWh)			
Consumers	Ships	Workshops	Offices	Total
	253.44	63.36	0.40625	317.2063
	Monthly Consumption (GWh)			
Jan	7.85664	1.96416	0.012594	9.833394
Feb	7.09632	1.77408	0.011375	8.881775
Mar	7.85664	1.96416	0.012594	9.833394
Apr	7.6032	1.9008	0.012188	9.516188
May	7.85664	1.96416	0.012594	9.833394
Jun	7.6032	1.9008	0.012188	9.516188
Jul	7.85664	1.96416	0.012594	9.833394
Aug	7.85664	1.96416	0.012594	9.833394
Sep	7.6032	1.9008	0.012188	9.516188
Oct	7.85664	1.96416	0.012594	9.833394
Nov	7.6032	1.9008	0.012188	9.516188
Dec	7.85664	1.96416	0.012594	9.833394
Total Annual Consumption (GWh)				115.7802813

Table 5. The Annual Energy Consumption of the Naval Base in Salamis

### 3. Wind Energy

The data for the wind energy, as and in the rest RES, is divided into two parts. The first is the wind potential for the examined area and the second is the

technical data of the wind turbine that is going to be installed. Table 1 provides the data for the wind speeds per month.

In the market, there are many available wind turbines with different characteristics. A 4.5MW wind turbine could be a possible choice, because in comparison with smaller wind turbines it has more advantages for this project. That choice will produce the desired energy with fewer units, since there is a free space limitation due to the high population density of Salamis. Although the sizes of the auxiliary units would be larger to handle the power, they would be less in number, which can have a financial reduction to the cost of the project. The fewer wind turbines will alter the natural environment in smaller scale than with more and smaller turbines.

Another important aspect that is affecting the choice of wind turbines is the rated wind speed. It should be as close to the average wind speed of the area, since that way the efficiency and the power production would be as high as possible.

Wind Turbine Specifications			
Rated Power	4.5MW	Rotor Diam.	120m
Cut-in Speed	3m/s	No of Blades	3m
Rated Speed	9m/s	Std Hub Height	128m
Top Speed	28m/s		
Sound Level	102dB(A) at 8m/s wind speed		

Table 6. Significant Wind Turbine Specifications



Figure 34. Typical Wind Turbine Power Curve

Regarding the cost analysis, the cost of installing a 4.5MW wind turbine is assumed to be about €5 million. In the case of installing more than one, there will be a reduction of the unit cost. Moreover, the annual operation and maintenance cost is usually 3–5% of the installation cost or €7–26/MWh.

Usually, the lifetime of a wind turbine with the proper maintenance schedule can be assumed to be about 20–30 years.

#### 4. Solar Power

The most significant factor of solar energy, which defines the efficiency and the power production of a solar panel, is the solar radiation. The values of the radiation are obtained by RETScreen.

Month	Monthly Average Solar Radiation (KWh/m <sup>2</sup> )
Jan	4.041687548
Feb	4.570725129
Mar	6.510280996
Apr	7.95494918
May	9.027881182
Jun	9.936025129
Jul	10.82138355
Aug	10.08559649
Sep	7.548941418
Oct	5.806214429
Nov	4.621873397
Dec	3.463052821

Table 7. Monthly Average Solar Radiation the Last Four Years

Since the technology of PVP is evolving rapidly, there many kinds and configurations available in the market, that could be applicable in Salamis. A suitable configuration is that with two-axis tracking, which turns the panel continuously to the sun. That way, the panel is perpendicular to the suns radiation having the optimal power generation during the day.

The installation of a PVP has a cost estimation of about €3–7/W with the higher value for PVP with two-axis tracking system or about €2/W with no tracking system. The annual maintenance cost is low, compared with other

technologies and is about €35/year. The value that is used more often depends on the power production of the PVP. Assuming that a 1KW PVP, at the average cost, is producing in its time life 35000KWh, the cost of installation is:

$$Initial\ Cost = \frac{E7}{Watt} * 1000Watt = E7000$$

$$Cost = \frac{E7000}{35000KWh} = \frac{E0.20}{KWh}$$

## 5. Other RES

The wave power conversion is not popular at the time and the applied techniques are under evaluation. Thus, the optimization programs do not have the option for this RES. Knowing that Salamis has the potential of wave power, it is a source that may partial cover future energy needs.

In addition, geothermal power is not supported from the programs and there is not any major geothermal energy source in Salamis, like there is in Iceland. Therefore, the geothermal power is limited to the residential level, where it can be used for house heating, decreasing by extension the energy consumption of the community.

## 6. Other Components

There are more components than the usual, wing turbine and PVPs, that although are not RES, they can be considered as RES. Those components are the batteries and the combination of fuel cells-electrolyzer-H<sub>2</sub> tank, which are used to store energy, produced by the RES, and have it available when there is lack of energy.

Another component that is vital for the system is the inverter. Since the RES usually are producing DC and the loads are using AC, there must be an inverter as a link between the currents. Once again, since there are various kinds of inverters in the market, the choice should be done with respect to the available space on the island for installation. An estimation of cost of an inverter is about

€0.54–0.56/W and the operation and maintenance cost as high as 5% of the initial cost per year, while its lifetime can be more than ten year up to twenty-five.

1MW Inverter Specifications	
Initial Cost	€ 550,000
O&M Cost/year	€ 27,500
Lifetime (years)	10
Efficiency (%) vs. Output Power (%rated power)	
0	0
5	95.5
10	97
20	98
30	98
40	98
50	97.9
60	97.8
70	97.6
80	97.4
90	97.2
100	97

Table 8. Significant Technical Specifications of an Inverter

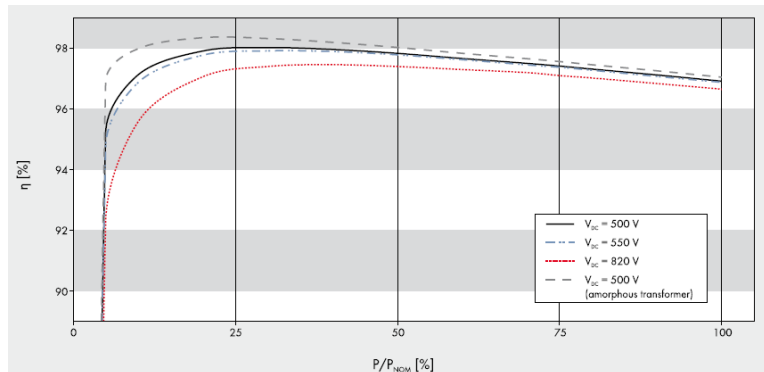

Figure 35. Typical Diagram  $\eta(\%)$  vs. Output Power (% Rated Power) of an Inverter

### C. ENERGY SOURCE OPTIMIZATION

Using the specifications of the systems that are available in the market, the energy source optimization is easier using any of the available programs. The strategy, which is applied in this study, is using a program to extract the optimum number and combination of systems and then verify and/or improve the results using the rest.

## 1. HOMER

HOMER has the potential to have as inputs the installation, operation and maintenance cost, along with the technical data of the wind turbines, PVPs and inverter and calculates the optimum compilation of systems and its sizes, the initial cost, the cost of the produced kWh and the energy balance of the system. All calculations are done with respect to the constraints or sensitivity values the user provides, such as the maximum capacity shortage and the renewable fraction.

The capacity shortage fraction is equal to the total capacity shortage divided by the total electric load. A system is considered feasible (or acceptable) only if the capacity shortage fraction is less than or equal to the maximum annual capacity shortage.

$$f_{cs} = \frac{E_{cs}}{E_{tot}}$$

The renewable fraction is the portion of the system's total energy production originating from renewable power sources. HOMER calculates the renewable fraction by dividing the total annual renewable power production (the energy produced by the PV array, wind turbines, hydro turbine, and biogas-fueled generators) by the total energy production.

$$f_{ren} = \frac{E_{ren} + H_{ren}}{E_{tot} + H_{tot}}$$

The reason of using those sensitivity parameters and changing their values is creating a system, where if the target of converting an area into green is not feasible, the creation of an area as much close to green would be possible. Moreover, the fact that Salamis is not isolated and already on grid give the flexibility of using the best financial combination of subsystems, achieving at the same time energy excess on usual days, although the energy needs on peak days are not fully covered.

The excess of energy is sold to the grid and that way it reduces the cost of the produced kWh. Since that way, not only the energy needs of Salamis are covered, but also partial needs of the rest grid are covered, there is less need for power production through conventional means and the reduction of emission is achieved in a greater area.

Creating different cases, because the cost of each subsystem can be reduced by the manufacturer according to the number of subsystems in the order, different combinations are created, feasible and cost effective. Some combinations, although are optimum, are not feasible in reality, due to the number of subsystems used and the free area constraint of the island.

	Wind Turbine			PVP			Converter		
	Power (MW)	Installation Cost (E)	O&M Cost (E)	Power (MW)	Installation Cost (E)	O&M Cost (E)	Power (MW)	Installation Cost (E)	O&M Cost (E)
<b>Case 1</b>	2	2850000	142500	1	9000000	35	1	420000	21000
<b>Case 2</b>	4.5	5000000	250000	1	9000000	35	1	420000	21000
<b>Case 3</b>	4.5	5000000	250000	1	9000000	35	1	420000	21000
<b>Case 4</b>	4.5	4000000	200000	1	6000000	35	1	420000	21000
<b>Case 5</b>	4.5	4000000	200000	1	3000000	35	1	420000	21000
<b>Case 6</b>	4.5	4000000	200000	1	3000000	35	1	420000	21000
<b>Case 7</b>	4.5	4000000	200000	1	3000000	35	1	350000	17500

Table 9. Cases Subject to Optimization

The optimization results for each case are:

	Max. Cap. Short. (%)	Min. RF (%)	PV (kW)	Wind Turbines	Converter (kW)	Grid (kW)	Initial Capital Cost (E)	Operating Cost (E/yr)	Total NPC (E)	COE (E/kWh)	RF	Cap. Short.	Energy Purchased (kWh)	Energy Sold (kWh)	Net Purchases (kWh)	Energy Charge (E)
Cs 1	---	---	150000	1200	260000	1000	4,879,200,256	175,661,344	6,894,021,632	2.528	1	0.1	356,838	8,396,013	-8,039,176	-803,918
Cs 2	---	---	---	100	180000	1000	575,600,000	27,964,764	896,353,600	0.33	1	0.1	300,639	8,453,075	-8,152,436	-815,244
	---	---	50000	100	140000	1000	1,008,800,000	27,110,616	1,319,756,544	0.479	1	0.09	220,323	8,531,732	-8,311,409	-831,141
Case 3	5	95	80000	114	280000	1000	1,407,600,000	33,533,296	1,792,224,256	0.644	1	0.05	130,767	8,625,908	-8,495,141	-849,514
	5	90	80000	114	280000	1000	1,407,600,000	33,533,296	1,792,224,256	0.644	1	0.05	130,767	8,625,908	-8,495,141	-849,514
	10	95	---	86	220000	1000	522,400,000	25,306,764	812,666,624	0.299	1	0.1	310,595	8,442,992	-8,132,398	-813,240
	10	90	---	86	220000	1000	522,400,000	25,306,764	812,666,624	0.299	1	0.1	310,595	8,442,992	-8,132,398	-813,240
Case 4	5	95	80000	114	280000	1000	1,407,600,000	33,533,296	1,792,224,256	0.644	1	0.05	130,767	8,625,908	-8,495,141	-849,514
	5	90	80000	114	280000	1000	1,407,600,000	33,533,296	1,792,224,256	0.644	1	0.05	130,767	8,625,908	-8,495,141	-849,514
	10	95	---	86	220000	1000	522,400,000	25,306,764	812,666,624	0.299	1	0.1	310,595	8,442,992	-8,132,398	-813,240
	10	90	---	86	220000	1000	522,400,000	25,306,764	812,666,624	0.299	1	0.1	310,595	8,442,992	-8,132,398	-813,240
Case 5	5	95	80000	120	220000	1000	1,052,400,000	27,773,576	1,370,960,640	0.493	1	0.05	131,975	8,624,263	-8,462,288	-849,229
	5	90	80000	120	220000	1000	1,052,400,000	27,773,576	1,370,960,640	0.493	1	0.05	131,975	8,624,263	-8,462,288	-849,229
	10	95	---	88	200000	1000	436,000,000	20,987,148	676,720,960	0.249	1	0.1	313,246	8,441,749	-8,128,503	-812,850
	10	90	---	88	200000	1000	436,000,000	20,987,148	676,720,960	0.249	1	0.1	313,246	8,441,749	-8,128,503	-812,850
Case 6	5	95	100000	108	220000	1000	824,400,000	25,374,040	1,115,438,208	0.401	1	0.05	129,294	8,623,922	-8,494,628	-849,463
	5	90	100000	108	220000	1000	824,400,000	25,374,040	1,115,438,208	0.401	1	0.05	129,294	8,623,922	-8,494,628	-849,463
	10	95	60000	56	180000	1000	479,600,000	14,158,156	641,992,896	0.233	1	0.1	253,993	8,493,434	-8,239,443	-823,944
	10	90	60000	56	180000	1000	479,600,000	14,158,156	641,992,896	0.233	1	0.1	253,993	8,493,434	-8,239,443	-823,944
Case 7	5	95	100000	104	260000	1000	807,000,000	24,504,840	1,088,068,608	0.391	1	0.05	133,008	8,619,616	-8,486,609	-848,661
	5	90	100000	104	260000	1000	807,000,000	24,504,840	1,088,068,608	0.391	1	0.05	133,008	8,619,616	-8,486,609	-848,661
	10	95	40000	62	220000	1000	445,000,000	15,427,128	621,947,968	0.226	1	0.1	253,178	8,495,926	-8,242,749	-824,275
	10	90	40000	62	220000	1000	445,000,000	15,427,128	621,947,968	0.226	1	0.1	253,178	8,495,926	-8,242,749	-824,275

Table 10. Optimization Results of Each Case

From the results, Case 1 is unfeasible since it needs the installation of too many wind turbines in order to cover the energy demands of Salamis. All the rest cases are feasible, based on the sensitivity values.

The overall optimum/ideal combination is that of Case 7 with 90% maximum capacitance shortage and 95% renewable fraction, since it has the minimum production cost of a kWh. In addition, that result has the minimum total net present cost, which is the present value of all the costs that it incurs over its lifetime, minus the present value of all the revenue that it earns over its lifetime. Costs include capital costs, replacement costs, O&M costs, fuel costs, emissions penalties, and the costs of buying power from the grid. Revenues include salvage value and grid sales revenue.

Analytically, this combination of wind turbines, PVPs and inverters has the following results:

<b>PVP</b>	40MW
<b>Wind Turbine</b>	62 X 4.5MW
<b>Grid</b>	1MW
<b>Inverter</b>	220MW
<b>Total Net Present Cost</b>	E 621,947,968
<b>Levelized Cost of Energy</b>	E 0.226/kWh
<b>Operating Cost</b>	E 15,427,128/yr

Table 11. System Architecture and Cost Summary

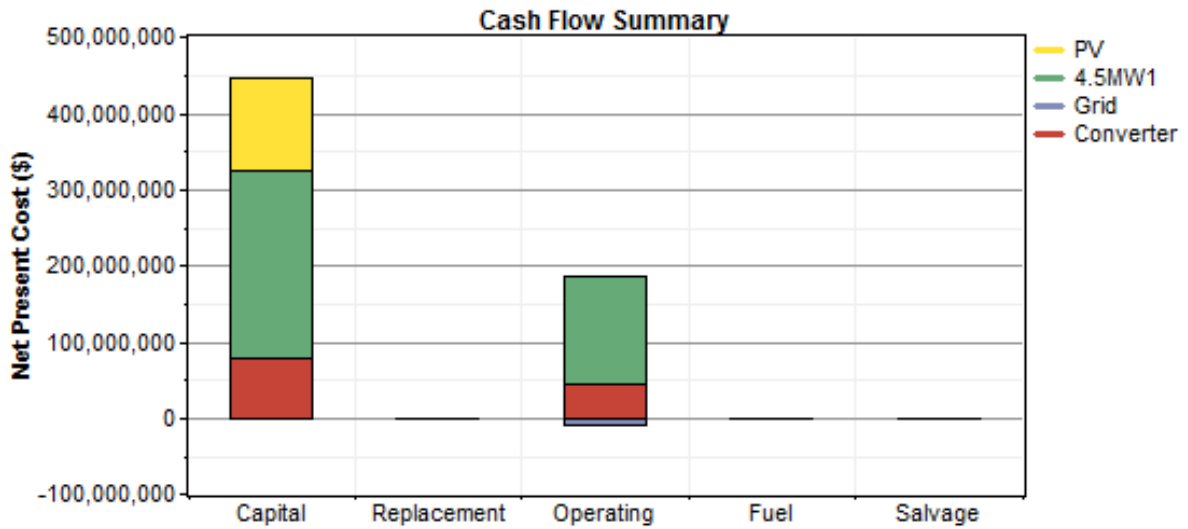

Figure 36. Cash Flow Summary

	Component	Capital	Replacement	O&M	Fuel	Salvage	Total
Net Present Costs	PV	120,000,000	0	16,058	0	0	120,016,064
	4.5MW1	248,000,000	0	142,227,088	0	0	390,227,072
	Grid	0	0	-9,454,372	0	0	-9,454,372
	Converter	77,000,000	0	44,159,216	0	0	121,159,208
	System	445,000,000	0	176,947,984	0	0	621,947,968
Annualized Costs	PV	10,462,147	0	1,400	0	0	10,463,547
	4.5MW1	21,621,770	0	12,400,005	0	0	34,021,772
	Grid	0	0	-824,275	0	0	-824,275
	Converter	6,713,211	0	3,850,002	0	0	10,563,212
	System	38,797,128	0	15,427,131	0	0	54,224,256

Table 12. Costs Analysis

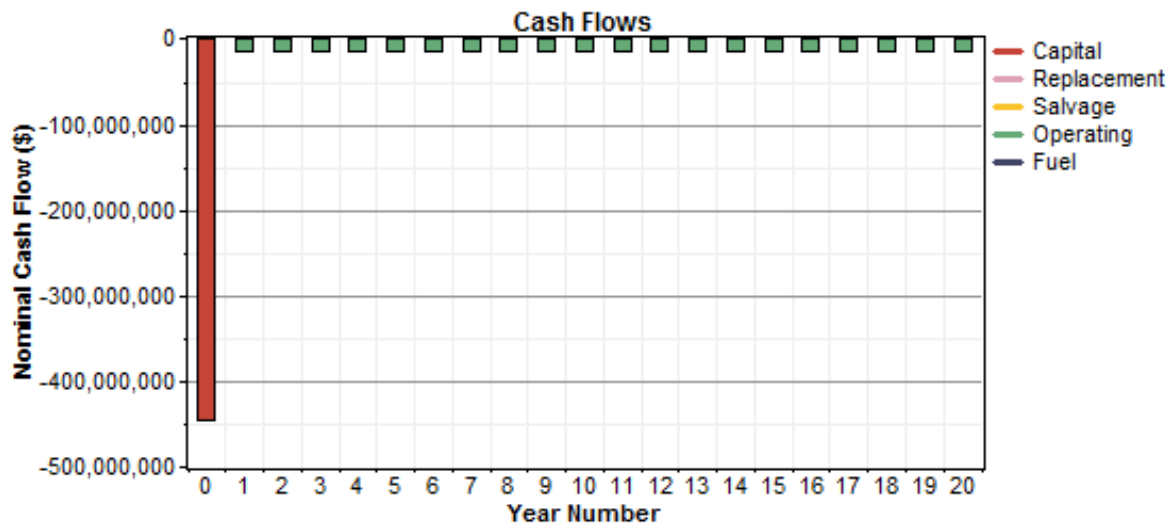

Figure 37. Annual Cost Summary

Component	Production	Fraction	Load	Consumption	Fraction	Quantity	Value	Units
	(kWh/yr)			(kWh/yr)				
PV Array	126,796,560	6%	AC Primary Load	239,652,752	97%	Excess Electricity	1,779,014,656	kWh/yr
Wind Turbines	1,905,210,880	94%	Grid sales	8,495,926	3%	Unmet Load	6,266,369	kWh/yr
Grid Purchases	253,178	0%				Capacity Shortage	24,701,018	kWh/yr
<b>Total</b>	<b>2,032,260,608</b>	<b>100%</b>	<b>Total</b>	<b>248,148,672</b>	<b>100%</b>	<b>Renewable Fraction</b>		<b>1%</b>

Table 13. Electrical System Summary

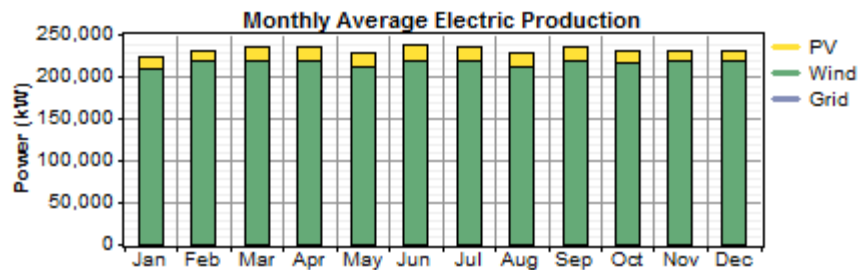

Figure 38. Monthly Average Electric Production

	PVP	Wind Turbine	Inverter	
Quantity	Value	Value		Units
Rated Capacity	40,000	279,000	220,000	kW
Mean Output	14,474	217,490	28,299	kW
Mean Output	347,388			kWh/d
Capacity Factor	36.2	78	12.9	%
Total Production	126,796,560	1,905,210,880		kWh/yr
Minimum Output	0	0	0	kW
Maximum Output	41,691	279,000	220,000	kW
Penetration	51.6	775		%
Hours of Operation	4,383	8,567	8,720	hr/yr
Levelized Cost	0.0825	0.0179		E/kWh
Energy In			252,954,976	kWh/yr
Energy Out			247,894,896	kWh/yr
Losses			5,060,080	kWh/yr

Table 14. Component Summary

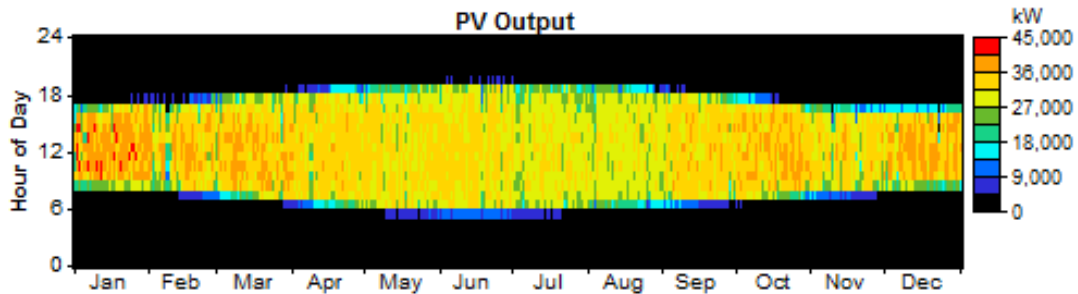

Figure 39. Annual PVP Power Production

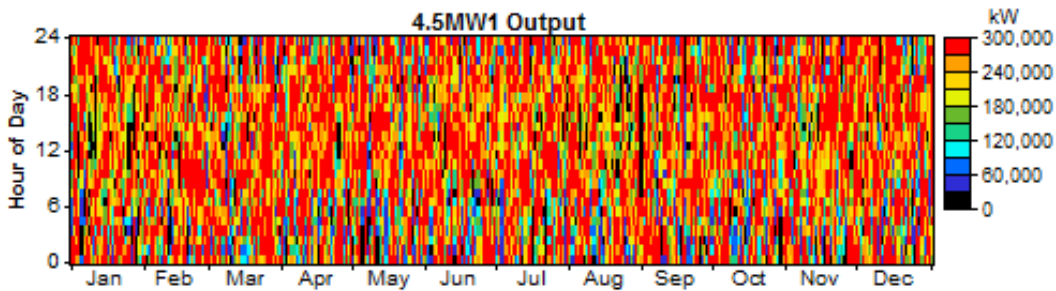

Figure 40. Annual Wind Turbine Production

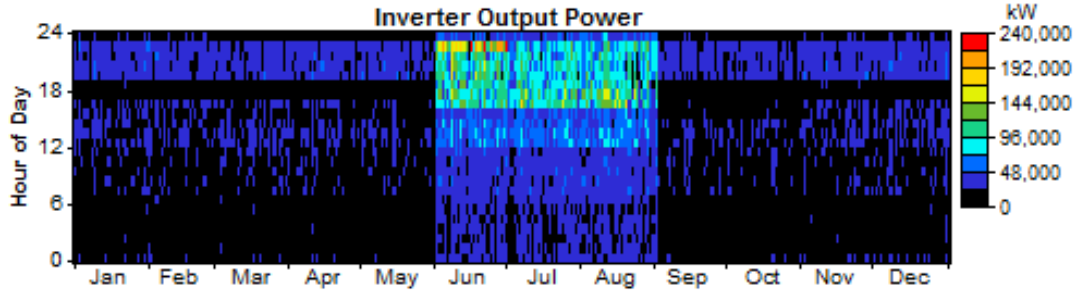

Figure 41. Annual Inverter Production

Month	Energy Purchased	Energy Sold	Net Purchases	Peak Demand	Energy Charge
	(kWh)	(kWh)	(kWh)	(kW)	(E)
Jan	24,902	719,000	-694,098	1,000	-69,410
Feb	10,666	659,869	-649,203	1,000	-64,920
Mar	13,069	730,000	-716,931	1,000	-71,693
Apr	10,232	709,000	-698,768	1,000	-69,877
May	13,136	730,000	-716,864	1,000	-71,686
Jun	38,287	678,555	-640,268	1,000	-64,027
Jul	37,400	706,000	-668,600	1,000	-66,860
Aug	58,224	684,589	-626,365	1,000	-62,637
Sep	12,161	707,000	-694,839	1,000	-69,484
Oct	10,101	733,000	-722,899	1,000	-72,290
Nov	12,000	707,980	-695,980	1,000	-69,598
Dec	13,000	730,934	-717,934	1,000	-71,793
Annual	253,178	8,495,926	-8,242,749	1,000	-824,275

Table 15. Grid Summary

Pollutant	Emissions (kg/yr)
Carbon Dioxide	-5,209,417
Carbon Monoxide	0
Unburned Hydrocarbons	0
Particulate Matter	0
Sulfur Dioxide	-22,585
Nitrogen Oxides	-11,045

Table 16. Emission Summary

## 2. HOGA

Using HOMER results, like the optimum number of wind turbines and PVPs and the optimum size of inverter, as inputs in HOGA, the software is forced to evaluate the given configuration/architecture. The results of HOGA will verify/improve or reject the configuration as not acceptable. The constrains of the system and the costs of installation, operation and maintenance are the same as those used in HOMER. The results of HOGA are:

<b>System Architecture</b>			
<b>Components</b>	<b>Quantity</b>	<b>Power</b>	<b>Total Power</b>
<b>PVP</b>	4 PV Serial X 40 PV Parallel	250kW	40MW
<b>Wind Turbines</b>	62	4.5MW	279MW
<b>Financial Details for 20 Years</b>			
<b>Initial Investment</b>		453900000	E
<b>Total System Costs</b>		-1077365888	E
<b>Levelized Cost of Energy (NPC)</b>		-0.22	E/kWh
<b>PVP Costs (NPC)</b>		120022976	E
<b>Wind Turbine Costs (NPC)</b>		451527200	E
<b>Inverter Costs (NPC)</b>		77000000	E
<b>Bought Energy (NPC)</b>		18381060	E
<b>Sold Energy (NPC)</b>		-1723172352	E
<b>Balance of System Energies for 1 Year</b>			
<b>Overall Load Energy</b>		246821952	kWh/yr
<b>Unmet Load</b>		9660760	kWh/yr
		3.91%	of Demanded Load
<b>Excess Energy</b>		1560003456	kWh/yr
<b>Energy Delivered by PVPs</b>		164630880	kWh/yr
<b>Energy Delivered by Wind Turbines</b>		1639383552	kWh/yr
<b>Energy Sold to Grid</b>		1267940362	kWh/yr
<b>Energy Purchased by Grid</b>		9660789	kWh/yr
<b>Total CO2 Emissions</b>		14579166	kg CO2/yr

Table 17. System Summary HOGA

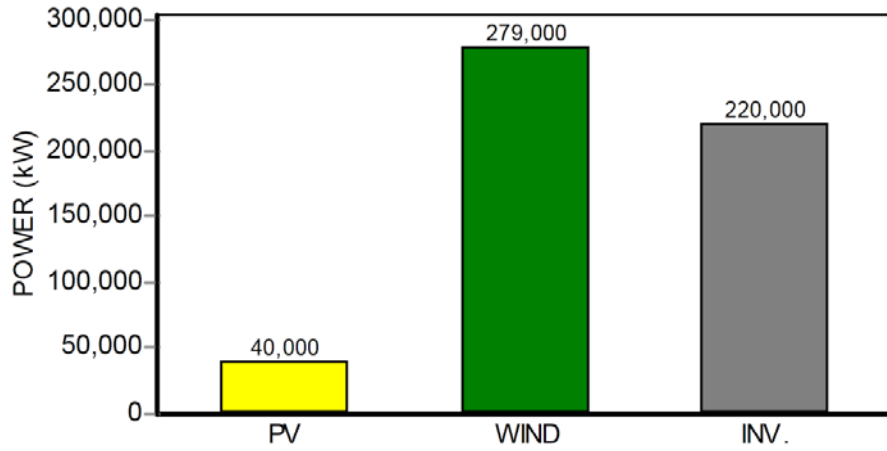

Figure 42. Nominal Power Production of Components

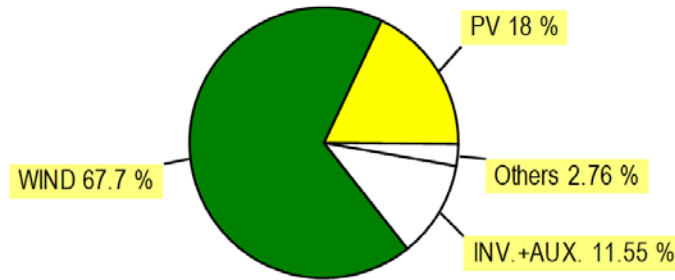

Figure 43. Cost by Component

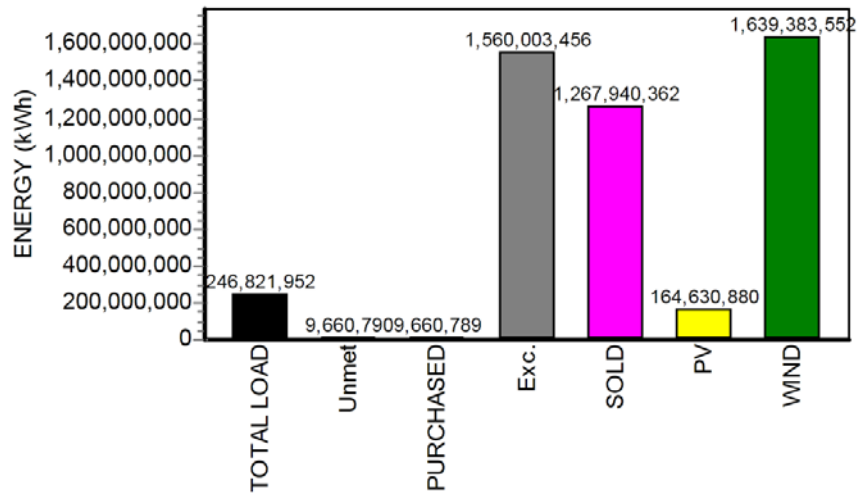

Figure 44. Cost Summary HOGA

### 3. RETScreen

In the same manner, the results of RETScreen will verify or reject the system architecture of the previous software. RETScreen's ability to calculate the payback period of the system will indicate if the configuration of the system is financially feasible.

Proposed case power system		Incremental initial costs	
Base load power system Technology: Wind turbine			
Analysis type: ○ Method 1 ○ Method 2 ● Method 3			
Resource assessment		Show data	
Resource method		Wind speed	Athens/Hellenikon
Month		m/s	m/s
January		11.3	3.3
February		9.2	3.8
March		8.5	3.5
April		8.6	3.0
May		7.6	3.0
June		6.4	3.3
July		6.4	3.7
August		11.1	3.8
September		8.5	3.3
October		8.2	3.2
November		6.4	3.2
December		6.0	3.4
Annual		9.3	3.4
Electricity export rate		€/MWh	
January		100.0	148,488
February		100.0	125,008
March		100.0	129,247
April		100.0	121,397
May		100.0	111,260
June		100.0	104,656
July		100.0	109,086
August		100.0	118,334
September		100.0	121,030
October		100.0	120,010
November		100.0	126,872
December		100.0	131,306
Annual		100.0	1,465,494
Measured at		m	10.0
Wind shear exponent			10.0
Wind turbine			
Power capacity per turbine		kW	4,500.0
Manufacturer			SIL
Model			4.5MW
Number of turbines			62
Power capacity		kW	279,000.0
Hub height		m	100.0
Rotor diameter per turbine		m	136
Swept area per turbine		m <sup>2</sup>	850
Energy curve data			Custom
Shape factor			2.0
Measured at			10.0
Wind shear exponent			10.0
Wind turbine			
Power capacity per turbine		kW	4,500.0
Manufacturer			SIL
Model			4.5MW
Number of turbines			62
Power capacity		kW	279,000.0
Hub height		m	100.0
Rotor diameter per turbine		m	136
Swept area per turbine		m <sup>2</sup>	850
Energy curve data			Custom
Shape factor			2.0
Measured at			10.0
Wind shear exponent			10.0
Wind turbine			
Power capacity per turbine		kW	4,500.0
Manufacturer			SIL
Model			4.5MW
Number of turbines			62
Power capacity		kW	279,000.0
Hub height		m	100.0
Rotor diameter per turbine		m	136
Swept area per turbine		m <sup>2</sup>	850
Energy curve data			Custom
Shape factor			2.0
Measured at			10.0
Wind shear exponent			10.0
Wind turbine			
Power capacity per turbine		kW	4,500.0
Manufacturer			SIL
Model			4.5MW
Number of turbines			62
Power capacity		kW	279,000.0
Hub height		m	100.0
Rotor diameter per turbine		m	136
Swept area per turbine		m <sup>2</sup>	850
Energy curve data			Custom
Shape factor			2.0
Measured at			10.0
Wind shear exponent			10.0
Wind turbine			
Power capacity per turbine		kW	4,500.0
Manufacturer			SIL
Model			4.5MW
Number of turbines			62
Power capacity		kW	279,000.0
Hub height		m	100.0
Rotor diameter per turbine		m	136
Swept area per turbine		m <sup>2</sup>	850
Energy curve data			Custom
Shape factor			2.0
Measured at			10.0
Wind shear exponent			10.0
Wind turbine			
Power capacity per turbine		kW	4,500.0
Manufacturer			SIL
Model			4.5MW
Number of turbines			62
Power capacity		kW	279,000.0
Hub height		m	100.0
Rotor diameter per turbine		m	136
Swept area per turbine		m <sup>2</sup>	850
Energy curve data			Custom
Shape factor			2.0
Measured at			10.0
Wind shear exponent			10.0
Wind turbine			
Power capacity per turbine		kW	4,500.0
Manufacturer			SIL
Model			4.5MW
Number of turbines			62
Power capacity		kW	279,000.0
Hub height		m	100.0
Rotor diameter per turbine		m	136
Swept area per turbine		m <sup>2</sup>	850
Energy curve data			Custom
Shape factor			2.0
Measured at			10.0
Wind shear exponent			10.0
Wind turbine			
Power capacity per turbine		kW	4,500.0
Manufacturer			SIL
Model			4.5MW
Number of turbines			62
Power capacity		kW	279,000.0
Hub height		m	100.0
Rotor diameter per turbine		m	136
Swept area per turbine		m <sup>2</sup>	850
Energy curve data			Custom
Shape factor			2.0
Measured at			10.0
Wind shear exponent			10.0
Wind turbine			
Power capacity per turbine		kW	4,500.0
Manufacturer			SIL
Model			4.5MW
Number of turbines			62
Power capacity		kW	279,000.0
Hub height		m	100.0
Rotor diameter per turbine		m	136
Swept area per turbine		m <sup>2</sup>	850
Energy curve data			Custom
Shape factor			2.0
Measured at			10.0
Wind shear exponent			10.0
Wind turbine			
Power capacity per turbine		kW	4,500.0
Manufacturer			SIL
Model			4.5MW
Number of turbines			62
Power capacity		kW	279,000.0
Hub height		m	100.0
Rotor diameter per turbine		m	136
Swept area per turbine		m <sup>2</sup>	850
Energy curve data			Custom
Shape factor			2.0
Measured at			10.0
Wind shear exponent			10.0
Wind turbine			
Power capacity per turbine		kW	4,500.0
Manufacturer			SIL
Model			4.5MW
Number of turbines			62
Power capacity		kW	279,000.0
Hub height		m	100.0
Rotor diameter per turbine		m	136
Swept area per turbine		m <sup>2</sup>	850
Energy curve data			Custom
Shape factor			2.0
Measured at			10.0
Wind shear exponent			10.0
Wind turbine			
Power capacity per turbine		kW	4,500.0
Manufacturer			SIL
Model			4.5MW
Number of turbines			62
Power capacity		kW	279,000.0
Hub height		m	100.0
Rotor diameter per turbine		m	136
Swept area per turbine		m <sup>2</sup>	850
Energy curve data			Custom
Shape factor			2.0
Measured at			10.0
Wind shear exponent			10.0
Wind turbine			
Power capacity per turbine		kW	4,500.0
Manufacturer			SIL
Model			4.5MW
Number of turbines			62
Power capacity		kW	279,000.0
Hub height		m	100.0
Rotor diameter per turbine		m	136
Swept area per turbine		m <sup>2</sup>	850
Energy curve data			Custom
Shape factor			2.0
Measured at			10.0
Wind shear exponent			10.0
Wind turbine			
Power capacity per turbine		kW	4,500.0
Manufacturer			SIL
Model			4.5MW
Number of turbines			62
Power capacity		kW	279,000.0
Hub height		m	100.0
Rotor diameter per turbine		m	136
Swept area per turbine		m <sup>2</sup>	850
Energy curve data			Custom
Shape factor			2.0
Measured at			10.0
Wind shear exponent			10.0
Wind turbine			
Power capacity per turbine		kW	4,500.0
Manufacturer			SIL
Model			4.5MW
Number of turbines			62
Power capacity		kW	279,000.0
Hub height		m	100.0
Rotor diameter per turbine		m	136
Swept area per turbine		m <sup>2</sup>	850
Energy curve data			Custom
Shape factor			2.0
Measured at			10.0
Wind shear exponent			10.0
Wind turbine			
Power capacity per turbine		kW	4,500.0
Manufacturer			SIL
Model			4.5MW
Number of turbines			62
Power capacity		kW	279,000.0
Hub height		m	100.0
Rotor diameter per turbine		m	136
Swept area per turbine		m <sup>2</sup>	850
Energy curve data			Custom
Shape factor			2.0
Measured at			10.0
Wind shear exponent			10.0
Wind turbine			
Power capacity per turbine		kW	4,500.0
Manufacturer			SIL
Model			4.5MW
Number of turbines			62
Power capacity		kW	279,000.0
Hub height		m	100.0
Rotor diameter per turbine		m	136
Swept area per turbine		m <sup>2</sup>	850
Energy curve data			Custom
Shape factor			2.0
Measured at			10.0
Wind shear exponent			10.0
Wind turbine			
Power capacity per turbine		kW	4,500.0
Manufacturer			SIL
Model			4.5MW
Number of turbines			62
Power capacity		kW	279,000.0
Hub height		m	100.0
Rotor diameter per turbine		m	136
Swept area per turbine		m <sup>2</sup>	850
Energy curve data			Custom
Shape factor			2.0
Measured at			10.0
Wind shear exponent			10.0
Wind turbine			
Power capacity per turbine		kW	4,500.0
Manufacturer			SIL
Model			4.5MW
Number of turbines			62
Power capacity		kW	279,000.0
Hub height		m	100.0
Rotor diameter per turbine		m	136
Swept area per turbine		m <sup>2</sup>	850
Energy curve data			Custom
Shape factor			2.0
Measured at			10.0
Wind shear exponent			10.0
Wind turbine			
Power capacity per turbine		kW	4,500.0
Manufacturer			SIL
Model			4.5MW
Number of turbines			62
Power capacity		kW	279,000.0
Hub height		m	100.0
Rotor diameter per turbine		m	136
Swept area per turbine		m <sup>2</sup>	850
Energy curve data			Custom
Shape factor			2.0
Measured at			10.0
Wind shear exponent			10.0
Wind turbine			
Power capacity per turbine		kW	4,500.0
Manufacturer			SIL
Model			4.5MW
Number of turbines			62
Power capacity		kW	279,000.0
Hub height		m	100.0
Rotor diameter per turbine		m	136
Swept area per turbine		m <sup>2</sup>	850
Energy curve data			Custom
Shape factor			2.0
Measured at			10.0
Wind shear exponent			10.0
Wind turbine			
Power capacity per turbine		kW	4,500.0
Manufacturer			SIL
Model			4.5MW
Number of turbines			62
Power capacity		kW	279,000.0
Hub height		m	100.0
Rotor diameter per turbine		m	136
Swept area per turbine		m <sup>2</sup>	850
Energy curve data			Custom
Shape factor			2.0
Measured at			10.0
Wind shear exponent			10.0
Wind turbine			
Power capacity per turbine		kW	4,500.0
Manufacturer			SIL
Model			4.5MW
Number of turbines			62
Power capacity		kW	279,000.0
Hub height		m	100.0
Rotor diameter per turbine		m	136
Swept area per turbine		m <sup>2</sup>	850
Energy curve data			Custom
Shape factor			2.0
Measured at			10.0
Wind shear exponent			10.0
Wind turbine			
Power capacity per turbine		kW	4,

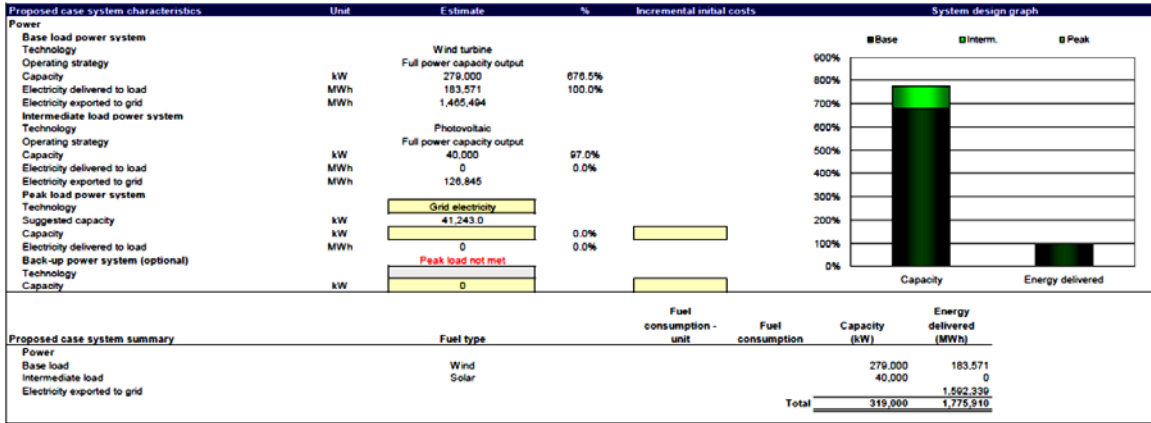

Figure 46. Proposed System Characteristics

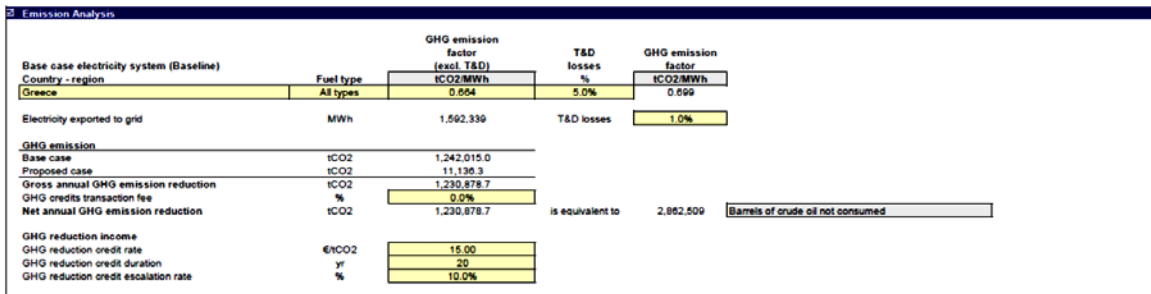

Figure 47. Emission Analysis

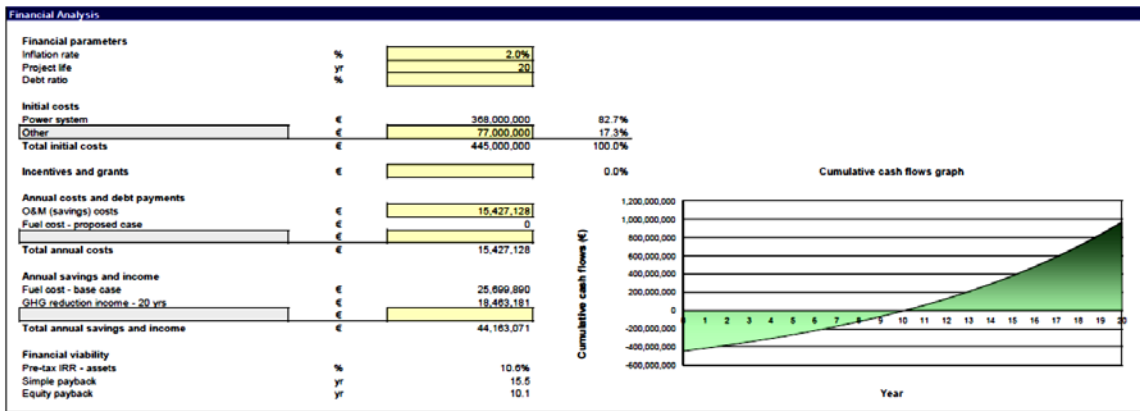

Figure 48. Financial Analysis

#### **4. Hybrid2 and ViPOR**

Hybrid2 and ViPOR are created for smaller applications and thus they do not have the potential to handle too many power sources. Since the power sources needed for this project are many and distributed all over the island, although by concentrating groups of sources as one those programs can perform optimization, the results will be questionable. Those programs are better to be used for residences and other applications, like ships and for small villages.

#### **D. SOURCE LOCATIONS**

The last task of installing the wind turbines and the PVPs is deciding the area, where they will have the optimum. The choice of area will be done with respect to the weather conditions, the morphology and the distance from cities and residences. Although the distance from the main grid station of the island is adding more cost to the project, the number of wind turbines and PVPs are forcing to use all the available free space on the island.

##### **1. Wind Turbines**

Several aspects must be taken into consideration during the installation of wind turbines.

They need clean airflow with minimum as possible fluctuations in speed and direction. In order to acquire those wind characteristics, wind turbines must be placed in an area with no obstacles. In addition, the wind must have the speed potential to provide enough energy to the wind turbine and produce more electric energy with higher efficiency. Since most wind turbine can change their direction relative to the wind, the fact that are placed in a free of obstacles area allow wind turbines to take advantage of winds from every direction. The most suitable areas for onshore wind turbine installations are on top of hill and mountains. On the contrary, the relative altitude of the mountains should be low,

because on high altitudes, the air density is lower and the efficiency of wind turbines is inversely proportional to air density. The highest point of Salamis is 404 meters and does not affect greatly the air density.

Another significant aspect is that wind turbines must have a distance between them to maintain their efficiency. The wind characteristics passing the rotor blade area are changing, due to friction and fluctuations. The fluctuations are creating vortexes that influence the airflow for a distance until they are decaying in the flow. While the optimum spacing between two wind turbines was about seven times the rotor diameter, today it is found that the optimum spacing is even larger and close to fifteen times the rotor blade. In that distance, the airflow has the initial characteristics and the second wind turbine can have the same efficiency as the first. The height of the wind turbine tower allows the installation on the hillside, while the rotor is above the top of the hill; give a more dense installation always with the suitable distance between them.

The advanced technology of big wind turbines has the advantage of installing the wind turbines in a shorter distance than fifteen times their rotor diameter and has a negligible loss in their efficiency. In addition, those wind turbines are relatively quieter than smaller, allowing the installation closer to residences.

Although the choice of the biggest available wind turbine reduced significantly the number of required wind turbines from 1200 2.0MW to 62 4.5MW, the task of installing those 62 wind turbines in Salamis is challenging based on high residential density and the archeological sites. However, the technical specifications of the wind turbine can partly simplify this task.

The distance between wind turbines and from residences is about 1500 meters so that all wind turbines could fit on the island and the sites of installation are chosen with respect to wind energy potential map of Salamis.



Figure 49. Wind Turbine Sites

## 2. Photovoltaic Panels

The panels for this project, although they provide less energy than wind turbines, need significant area for their installation.

As wind turbines need clean airflow for higher efficiency, solar panel need to be under direct influence of the solar radiation. Thus, the sites of installation need to be free of obstacles, which can reduce the effective solar radiation. Key

point also in PVPs is their orientation, but the installation of PVPs with two-axis tracking system minimizes this problem.

Usually a 1MW of PVPs need about a hectare for installation, hence in this project, since the needed PVPs should have 40MW power, the total available area should be about 40 hectares or 400,000m<sup>2</sup>.

PVPs can also be installed on the roofs of residences taking advantage of the available space and living more space free for future installation and application. The reason of not choosing the roofs is that this space should be available for citizens to install small residential PVPs. Those energy independent residences will produce energy mostly when the energy needs are high and unmet by the installed wind turbines and PVPs, while with the proper energy storage techniques, which can be applied due to the significantly smaller individual residential energy needs, they can be energy independent even when the PVPs do not produce sufficient power. That way, although that most of the electric demands of the island are covered, there is additional energy production at a residential level, which contributes to the general effort of converting Salamis into a green area. Moreover, more energy will be available for selling to the main grid and the total unmet load will be even less and by extension so will the cost per kWh and the payback time.

The most suitable sites for installation are the slopes of hills oriented south. The fact that in some cases the site is also chosen for wind turbine installation does not affect PVPs, because their blocking of solar radiation can be assumed negligible.



Figure 50. PVP Sites

## E. ENERGY BALANCE AND EXCESS

From the results of the three softwares, it is easily seen that the suggested number of wind turbines and PVPs does not cover the peak energy needs of the island. There is about 4-5% of unmet load, which is covered by the main grid and conventional energy production. On the other hand, when the energy needs are average the system has energy excess, which is provided to the grid for further exploitation.

The systems' characteristics and inputs are the same in each software, though the approach of each one is different because they perform different analysis of the project. HOMER is performing the analysis with respect to net preset cost, while HOGA is optimizing total system cost throughout the whole of its useful lifespan and/or the equivalent CO<sub>2</sub> emissions. On the other hand, RETScreen is calculating the viability of the project based on the emissions of CO<sub>2</sub> and the payback time.

Another reason, that the software results are different, is because of the inputs. Since the weather inputs of wind speed and solar radiation is the average values per month and each program is using a normal distribution to produce sufficient data for calculations, even a small difference in this distribution can alter the results significantly. This is more obvious considering the efficiency curve of the wind turbine (Figure 34). The average wind speed of Salamis is close the area of the curve with the larger slope, meaning that a small change in the speed will result in a relatively large change in the produced energy.

Although there are different results from each program, there is a common result that the total project has energy excess. This energy excess is that balance the fact that the derived configuration cannot cover the peak loads of the community. The variations in loads are large due to the large differences in seasonal population. In order to make the project viable, a tradeoff had to be made between viability and creating a completely green area. For a 100% green area the required wind turbines and PVPs would be so many that, the project would be unviable, because of the high cost per kWh produced or because of lack of free space for installation (Table 10. Cs 2).

Each program produce results where the total energy excess is significantly larger than the total energy needed from the grid. This is happening mainly due to the size and the efficiency curve of the wind turbines. A comparison of the results could give an estimation of energy balance and excess of the system.

Software	Energy Produced	Energy Sold	Energy Purchased	Net Energy Sold	Units
HOMER	2032007440	1787510582	6519547	1780991035	kWh/yr
HOGA	1804014432	1267940362	9660789	1258279573	kWh/yr
RETScreen	1775910000	1592339000	15931760	1576407240	kWh/yr

Table 18. Energy Balance and Excess

RETScreen does not calculate directly the energy purchased by the grid, but it can be approximately calculated by the emission analysis (Figure 47).

$$Energy\ Purchaced = \frac{proposed\ case}{GHG\ emission\ factor} = \frac{11136.3tCO_2}{0.699 \frac{tCO_2}{MWh}} = 15931.76MWh$$

Overall, HOMER has the best performance with respect to the net energy sold, while HOGA is the most conservative. The fact that both programs have the same cost of energy production indicates that the suggested system configuration is of the best solutions of the project. RETScreen is in the middle, since it is not a cost optimization software, but a emission minimization software with totally different architecture.

## F. EFFICIENCY

There many way of calculating the efficiency of the suggested system architecture and none of them is trivial and there are many efficiencies/ratios with respect to different variables that can be calculated giving different estimations for the viability of the project. Wind turbines and PVPs have their efficiency, while each software has a different approach of the project, optimizing different variables.

In addition, the task of finding the systems efficiency is very complex due to the variation of weather conditions, the average weather data used and the approximation of normal distribution of weather conditions from each program. Moreover, the efficiencies of wind turbines and PVPs are already taken into consideration in the energy production calculations, thus the total cost of the

project and the total energy production should be the base values for further estimation of the efficiency.

In this study, two ratios are going to be used, a technical and a financial. The technical one is going to be the RES energy consumed in Salamis versus energy demands of Salamis and the financial net cost of selling energy versus total cost. Those two approaches will give an estimation of the conversion of Salamis into a green area and an estimation of the cost reduction of the project, considering that the excess energy is sold to the grid.

Software	HOMER	HOGA	RETScreen	Units
Energy Demand	246172299	246821952	246816000	kWh/yr
Energy Consumption	239652752	237161192	183571000	kWh/yr
Ratio	97.351633	96.08594	74.37564826	%
Total Cost	55048531	32427509	37677128	E/yr
Net Energy Sold	177838321	125441526		E/yr
Annual Saving and Income			44169071	E/yr
Ratio	69.045743	74.149303	85.30206125	%

Table 19. Technical and Financial Ratios

Regarding the financial ratios, the calculations are done in the following manner for HOGA:

$$\begin{aligned}
 \text{Net Energy Sold} &= \text{Energy Excess} * \text{Cost of Selling} - \text{Energy Shortage} * \text{Cost of Purchase} \\
 &= 1267940362 \frac{\text{kWh}}{\text{yr}} * 0.1 \frac{\text{E}}{\text{kWh}} - 9660789 \frac{\text{kWh}}{\text{yr}} * 0.14 \frac{\text{E}}{\text{kWh}} = 125441526 \frac{\text{E}}{\text{yr}} \\
 \text{Ratio} &= \frac{\text{Net Energy Sold} - \text{Total Cost}}{\text{Net Energy Sold}} = \frac{125441526 - 32427509}{125441526} = 74.1493\%
 \end{aligned}$$

The calculations are the same for HOMER, but for RETScreen the results already include the annual saving and income (Figure48).

The different point of view of each software is more obvious by comparing the technical and financial ratios. Although HOMER and HOGA are close to the conversion of Salamis into a green area, their financial ratios differ and the ratios of RETScreen are not comparable with the rest. This is happening mainly due to the different strategy of calculating the sold and purchased energies and the normal distribution of weather conditions. Probably, those softwares have different round-off error. To this contributes the fact that every program has an error in the calculation of the energy needs of the community. In all three cases, the profit through greenhouse gases reduction credit is neglected.

The product of the multiplication of the technical and financial ratios can give a rough estimation of the projects efficiency.

<b>Software</b>	<b>Efficiency (%)</b>
<b>HOMER</b>	67.21715799
<b>HOGA</b>	71.24705442
<b>RETScreen</b>	63.44396103

Table 20. Project Efficiencies

The derived efficiency is much higher than the efficiency of fossil and lignite fuel power plants. Although, usually the efficiency of those plants does not have financial factors, the facts that the derived system has minimized the greenhouse gases emissions, is producing sufficient power for use in Salamis and is an additional energy source for the grid suggest that the systems configuration has higher efficiency.

<b>Power Plant</b>	<b>Efficiency (%)</b>
<b>Steam Turbine Fuel-Oil</b>	38 - 44
<b>Steam Turbine Coal-Fired</b>	39 - 47
<b>Pulverized Coal Boilers with Ultra-Critical Steam Parameters</b>	up to 47
<b>Atmospheric Circulating Fluidized Bed Combustion (CFBC)</b>	> 40
<b>Pressurized Fluidized Bed Combustion (PFBC)</b>	> 40
<b>Coal Fired IGCC</b>	> 43
<b>Large Gas Turbine (MW range)</b>	up to 39
<b>Large Gas Fired CCGT</b>	up to 58
<b>Biomass and Biogas</b>	30 - 40
<b>Biomass Gasification Combined Cycle</b>	40
<b>Waste-to-Electricity</b>	22 - 28
<b>Nuclear</b>	33 - 36

Table 21. Power Plants Efficiencies. After [17]

## VI. SYSTEM ANALYSIS

There is the ability of creating smaller territorial grids, but new tasks will be under examination, such as the energy balance of the smaller territory, the storage of the excess energy, considering the big changes of energy demands, and the financial feasibility of those sub grids. In addition, since the excess of energy for great time periods is too big, those sub grids have to be connected to the main grid or have adequate storage capabilities.

Those energy storage capabilities should be continuously increasing, since the energy excess is larger than the energy shortage and each of them occurring in different time. Hence, the energy stored will be untapped, unless there is a big period, when the RES are going to be unavailable. Even though the fact that the project is connected to the main grid implies that in those instances of RES unavailability, the energy needs are fully covered as it is done today, while the grid energy consumed is going to be recovered by the project on days or even time frames with energy excess.

The suggested configuration is the installation of sixty-two 4.5MW wind turbines, a total of 40MW photovoltaic panels and a total of 220MW inverters. That configuration does not meet the peak load of Salamis, but it is more financially feasible than other configurations. The cost of energy is the lowest, a result verified by two optimization programs.

In case that a configuration which covers the total needs of the island is needed, then two major problems occur. The first is the lack of free space for the installation of more wind turbines, which are the main contributors for energy production in this study and the total cost of the equipment.

The connection with the main grid allows the installation of fewer units and the peak loads are covered through it. From the optimization results, the energy from the grid, needed for the community, is much less than the energy the RES

can produce for the community and the grid. This energy excess is increasing the viability of the project making it more feasible both in technical and financial terms.

Another criterion that needs to be considered is its reliability and availability. Those key words are determining if a project is feasible. If a project has maximum efficiency, but it is available for much less time than another less efficient, then it is not feasible. Moreover, an examination of statistics of frequent malfunctions of the units should be made, in order to determine the reliability of the system, which affects the cost and the availability. A project with maximum efficiency, but low reliability is also rejected.

A system should also be examined for its flexibility and its ability to cover future energy needs, by its initial configuration or by addition of units. Especially in the energy sector, the needs are continuously varying with increasing tendencies. Therefore, the ability to serve as many demands as possible is a necessity.

Finally, a final system analysis is not going to be done just for RES, but in combination with the grid, since the latter is necessary for covering all the energy demands of Salamis.

## **A. ECONOMY**

The economic feasibility of the suggested configuration depends on many factors, which are not always subject of analysis. There is uncertainty in the financial analysis, due to the instability of global economy and the economy of each country.

The initial cost of purchasing and installing all the components is proportional to the manufacturer offer and the negotiations for better prices and support over the lifetime of the units. In many cases, the purchase of a large amount of units can reduce the initial cost significantly. Moreover, since there is an environmental concern and a tendency of depending more on RES, an

agreement of additional future purchases for other projects could also reduce the total cost. In addition, an agreement on using new experimental units, in order to examine their operational behavior in actual conditions, as a platform for real time experimentation improving their development can make the manufacturer think of further discounts. All those factors are based on the ability of the negotiator or even on specific country agreements and are not subject of examination in this study.

Assuming that the final cost of wind turbines, solar panels and inverters are as shown in Table 12, the cost of energy is about €0.22–0.23 per kWh produced. This cost is relatively high with respect to a conventional power plant, which is about €0.01 per kWh. The last value is calculated without including the initial capital of constructing and purchasing the units of the power plant. HOMER and HOGA verify the cost of energy. Those programs though do not include the greenhouse gas reduction credits in their cost analysis. This credit in combination with the reduction of any fine for environmental pollution will reduce even more the actual cost of energy. RETScreen is including the greenhouse gases reduction credit, but it does not calculate the cost of energy.

In addition, in the data used as input for the optimization program, the costs of operation and maintenance are considered to be maximum for each unit. That is of course worst-case scenario. In reality, we can expect better performance, and by extension, the total cost of the system will also be reduced.

Moreover, the system is under the maximum possible load, which is an assumption to neglect any unpredictable change of the load, mainly because of the naval base. Thus in reality, the load of the naval base is less and the system will have:

- More excess energy.
- Less unmet load and better ratio of converting Salamis into a green area.
- Less dependency on the grid.
- More greenhouse gases reduction.

- Better financial performance.

The high life cycle of the units and their warranty eliminates the cost of replacement for twenty years. This minimizes the total cost just to initial, operational and maintenance.

## **B. AVAILABILITY**

The availability of any power plant based on RES is questionable. There is always an uncertainty in weather forecast and since this project has its weather conditions based on past years and statistics, the availability of the project cannot be determined accurately.

The combination of three energy sources, the grid, wind turbines and solar panels, increases the availability of the system. The only case of no production is during a cloudy day with no wind, which is rare considering the geographical location and the weather statistics. Even in that case, the grid covers the energy needs. The energy purchase is then going to be paid back when the RES are available and the energy excess is feeding the grid.

The availability of the system is also tested by the availability of each unit. The availability of the units is based on the frequency of malfunctions and damages. Since all the units are under a twenty-year warranty, in any case the unit is going to be replaced with no additional cost.

Moreover, the time of replacement of any unit, installation and back-online can be from 5 to 20 days depending on the country of production. Lastly, the time of installation and back online can be minimized if the units are installed in modular architecture, where a unit is placed in module and is fitted on the proper foundation.

The maintenance work, that each unit needs, is also affecting the availability of the system. The three components of the system have different requirements for maintenance, but if those works are programmed carefully, the total reduction of the availability will be negligible.

The maintenance work of a wind turbine can be scheduled, based on the weather forecast, on days when the wind speed will be less than 3 m/s. That speed is the cut-off speed and below that the rotor is locked, since the efficiency of the turbine is too low.

In order to perform maintenance to the PVPs and their tracking system, the most suitable time is during night or on cloudy nights. Moreover, the ability of locking the panel in the optimum orientation allows any maintenance with the minimum losses and reduction of availability.

The installation of parallel inverters increases the flexibility of the system with respect to maintenance. On days when the energy production is low, inverters can be taken offline without interrupting the operation of the system.

Again, in case of malfunction and damage, the grid is a safety factor and can cover the needs.

### **C. RELIABILITY**

The reliability of the project is based on the reliability of each unit. The most sensitive unit of the configuration is the inverter. Therefore, the use of smaller inverters in parallel is going to reduce the losses of the system and will increase the reliability of the configuration.

The least sensitive unit is the solar panel, despite the fact that they have relatively increased sensitivity with other panels, due to the two-axis tracking mechanism. A manual mechanism of locking the panel in the azimuth and slope with the optimum efficiency, as in panels with no tracking device, can allow the continuous energy production of the panel until the tracking system is replaced or fixed. Since the panels are very reliable, they do not reduce the reliability of the project.

The most frequent malfunctions of an operating wind turbine are blade and structural damage, due to high wind speeds and fire due to electric

subcomponent failure. However, statistics have shown that any kind of damage is relatively rare. Therefore, the wind turbines are deemed reliable and do not reduce the overall system reliability.

#### **D. INITIAL COST RECOVERY**

This is a key factor in the viability of any project. If a project fails to recover the initial cost in its lifetime or in a reasonable time frame, then it is rejected, so it very important to achieve an overall profitable configuration for any system.

Based on the imported data, RETScreen has performed an analysis on the time of initial cost and on the time when the system is becoming profitable. The initial cost recovery is achieved in 10.1 years and the system becomes profitable in 15.5 years. Taking into consideration the fact that RETScreen is the most conservative software, the actual values should be less, indicating that the project will have even higher profit margin.

Those values are calculated based on the current financial factors that affect the economic analysis of the project. In case of having worst factors, there is a time frame of 4.5 years in which the project should have profit. Then the system is financial unfeasible and a different configuration should be examined.

#### **E FUTURE ENERGY NEEDS**

The future energy needs of Salamis are unknown and are based on the individual needs, which are also unknown. In addition, the naval base is a significant factor of uncertainty in any prediction for future needs, due to programs for purchasing new vessels and equipment.

Although future energy needs are unpredicted, there are several actions that can be taken. Some of these will cover the needs with the suggested configuration. Those actions are:

- Purchasing and installing of more PVPs in areas where wind turbines are already installed. The individual energy needs are occurring mostly during daytime when PVPs are also producing power.

- Installation of PVPs on roofs of residencies, which can cover residential needs. Therefore, more energy will be available for any needs.
- The connection with the grid and the excess of energy allow the purchase of more energy of the grid, while the project still has profits.
- The potential of wave energy in Salamis, which is now unexploited. Future testing and efficient applications can reveal a new source of energy and expand the total production.

The assumption that the needs of the naval base are assumed to be constant and the maximum possible indicate that the energy excess can be more than what calculated by the optimization projects. This additional excess can cover the uncovered energy peak or can cover the possible future needs depending on the time they occur.

THIS PAGE INTENTIONALLY LEFT BLANK

## VII. CONCLUSIONS AND RECOMMENDATIONS

This study presented a comprehensive technical and economic analysis of the feasibility of a green area in a realistic scenario. The community that was selected posed several challenges especially with regards to its size, complexity, population, and power needs. Based on the results of this thesis we can draw the following conclusions and recommendations for further research.

1. The global tendency of increasing the cost of fossil fuels and the savings occurring from the creation of a green area make the use of wind turbines, solar panels and other renewable energy sources a viable necessity.

2. Environmental concerns and worldwide results of pollution are enforcing the use of RES. This has an impact on the economic feasibility of the project.

3. The variability of financial factors such as discount rates can affect the feasibility of the project.

4. The signing of appropriate contracts with the manufacturers and appropriate legislation is a source of uncertainty that is difficult to accurately quantify in a realistic scenario.

5. There are several analysis and optimization programs, and each one has its advantages and disadvantages as explained in previous chapters. An overall study should take into consideration all aspects from all available software in order to produce meaningful and reliable results.

6. The benefits of converting Salamis into a green area are many:
- Reduction of greenhouse gases emissions by significant amounts.
  - It results in less fossil fuel consumption.
  - It makes large energy excess available to the grid for further exploitation.

- Overall, it offers more savings than costs for a twenty-year life project, based on the current values.

7. Naturally, there are some drawbacks or areas of concern, most notably, the following:

- Peak loads cannot be covered only from RES making necessary the connection with the grid. However, the actual project can be more feasible, since the real energy demands are less. Furthermore, modular installation of units can increase the availability and reliability of the overall system. Use and installation of many different RES is increasing system redundancy, availability and reliability.
- The large energy excess cannot be easily stored and its usage can be materialized only through the grid.

Some recommendations for further research are as follows:

1. The potential of using wave energy, in addition to the methods studied here. This may result in a realizable benefit.

2. A study of the social and economic impacts resulting from sensitization of the citizens for further:

- Reduction in energy losses.
- Production of energy with installation of solar panels on the roofs of their residence.
- Reduction of waste.
- Assistance in recycling programs.

3. Finally, as in every study, real results may be altered significantly, due to the variation of weather conditions and global economy. However, the results presented here have adequate tolerances and we do not anticipate big changes to the extent that they may render the project infeasible. This, however, can only be ascertained with further sensitivity analysis studies based on more realistic data.

## LIST OF REFERENCES

- [1] [http://en.wikipedia.org/wiki/Renewable\\_energy](http://en.wikipedia.org/wiki/Renewable_energy) (accessed on 2012/07/27)
- [2] <http://listverse.com/2009/05/01/top-10-renewable-energy-sources/> (accessed on 2012/07/27)
- [3] Dr. Nikitas Nikitakos, (June 2004). *“Agios Efstratios. A Green Island. An Environmental Approach”*, University of the Aegean, Greece.
- [4] National Informational Energy System, Ministry of Environment, Energy and Climate Change, <http://195.251.42.2/cgi-bin/nisehist.sh> (accessed on 2012/07/29)
- [5] <http://re.jrc.ec.europa.eu/pvgis/> (accessed on 2012/07/31)
- [6] E. Doumas, (May 2010), *“Coastal Vulnerability of Eastern Coasts of Saronic Golf in Extreme Sea Conditions,”* M.S. thesis, National, Technological University of Athens, Greece, available on line.
- [7] <http://www.iea.org/> (accessed on 2012/08/01)
- [8] Dr. Rodolfo Dufo – Lopez, Dr. Jose L. Bernal - Agustin, (July 2011), *“HOGA 1.96 User Manual”*, University of Saragossa, Spain, available online.
- [9] E. Ian Baring - Gould (February 1998). *“HYBRID2, The Hybrid System Simulation System, Users Manual”*, National Renewable Energy Laboratory, U.S. Department of Energy, available online.
- [10] J. F. Manwell, A. Rogers, G. Hayman, C. T. Avelar, J. G. McGowan, U. Abdlwahid, K. Wu (June 2006). *“HYBRID2, The Hybrid System Simulation System, Theory Manual”* Renewable Energy Research Laboratory, University of Massachusetts.
- [11] P. Lilienthal, T. Lambert, P. Gilman (April 2005). *“Getting Started Guide for HOMER Version 2.1”*, National Renewable Energy Laboratory, U.S. Department of Energy, available online.
- [12] *“RETScreen Software On line User Manual”*, RETScreen International, Canada, available online.
- [13] *“ViPOR, HelpTool”*, National Renewable Energy Laboratory, U.S. Department of Energy, available online.
- [14] Chistos A. Frangopoulos (2006). *“Advanced Naval and Marine Energy System”*, National Technological University of Athens, Greece.
- [15] Tai – Chee Wong, Belinda Yuen (2011). *“Eco – City Planning, Policies, Practice and Design”*, Singapore Institute of Planners, available online.
- [16] Molly Scott Cato (2009). *“Green Economics, An Introduction to Theory, Policy and Practice”*, Earthscan, London, UK.

- [17] Eurelectric Union of the Electricity Industry, VGB PowerTech (July 2003). *"Efficiency in Electricity Generation"*, available online.
- [18] D. Tsaknias, (September 2010), *"Cost Benefit Analysis of the Installation of a Wind Turbine on a Naval Ship,"* M.S. thesis, Naval Postgraduate School.

## INITIAL DISTRIBUTION LIST

1. Defense Technical Information Center  
Ft. Belvoir, Virginia
2. Dudley Knox Library  
Naval Postgraduate School  
Monterey, California
3. Fotis Papoulias  
Department of Mechanical and Aerospace Engineering  
Naval Postgraduate School  
Monterey, California
4. Nikitas Nikitakos  
Department of Shipping Trade and Transport  
University of Aegean  
Chios, Greece