Award Number:
W81XWH-10-2-0087

TITLE:
Mobile Gait Analysis System for Lower Limb Amputee High-Level
Activity Rehabilitation

PRINCIPAL INVESTIGATOR:
Boyd M. Evans, III, Ph.D.

CONTRACTING ORGANIZATION:
UT-Battelle, LLC

Oak Ridge, TN, 37830

REPORT DATE:
September 2012

TYPE OF REPORT:
Annual

PREPARED FOR: U.S. Army Medical Research and Materiel Command
Fort Detrick, Maryland 21702-5012

DISTRIBUTION STATEMENT:

Approved for public release; distribution unlimited

The views, opinions and/or findings contained in this report are those of the author(s) and should not be construed as an official Department of the Army position, policy or decision unless so designated by other documentation.

REPORT DOCUMENTATION PAGE			<i>Form Approved</i> <i>OMB No. 0704-0188</i>		
Public reporting burden for this collection of information is estimated to average 1 hour per response, including the time for reviewing instructions, searching existing data sources, gathering and maintaining the data needed, and completing and reviewing this collection of information. Send comments regarding this burden estimate or any other aspect of this collection of information, including suggestions for reducing this burden to Department of Defense, Washington Headquarters Services, Directorate for Information Operations and Reports (0704-0188), 1215 Jefferson Davis Highway, Suite 1204, Arlington, VA 22202-4302. Respondents should be aware that notwithstanding any other provision of law, no person shall be subject to any penalty for failing to comply with a collection of information if it does not display a currently valid OMB control number. PLEASE DO NOT RETURN YOUR FORM TO THE ABOVE ADDRESS.					
1. REPORT DATE (DD-MM-YYYY) 1 September 2012		2. REPORT TYPE Annual		3. DATES COVERED (From - To) 1 Sep 11-31 Aug 12	
4. TITLE AND SUBTITLE Mobile Gait Analysis System for Lower Limb Amputee High-Level Activity Rehabilitation			5a. CONTRACT NUMBER		
			5b. GRANT NUMBER W81XWH-10-2-0087		
			5c. PROGRAM ELEMENT NUMBER		
6. AUTHOR(S) Boyd M. Evans, III (ORNL); John Kyle P. Mueller (ORNL); Martin Pusch (Otto Bock Healthcare); Jason Wilken (Center for the Intrepid, BAMC) evansbmiii@ornl.gov			5d. PROJECT NUMBER		
			5e. TASK NUMBER		
			5f. WORK UNIT NUMBER		
7. PERFORMING ORGANIZATION NAME(S) AND ADDRESS(ES) UT-Battelle, LLC Oak Ridge, TN, 37830			8. PERFORMING ORGANIZATION REPORT		
9. SPONSORING / MONITORING AGENCY NAME(S) AND ADDRESS(ES) U.S. Army Medical Research and Materiel Command			10. SPONSOR/MONITOR'S ACRONYM(S)		
			11. SPONSOR/MONITOR'S REPORT NUMBER(S)		
12. DISTRIBUTION / AVAILABILITY STATEMENT Approved for public release; distribution unlimited					
13. SUPPLEMENTARY NOTES					
14. ABSTRACT The goal of this project is to develop a mobile gait analysis system (MGAS) for use on soldiers with lower limb prosthetics to improve prosthetic fit, alignment and training. This system involves detecting ground reaction forces and also sensing movement using inertial measurement units (IMUs) (accelerometers and gyroscopes). The Mobile Ground Reaction Force Sensor has been designed and the device housing and sensors have been fabricated. The "smart pylon" force/moment sensor has been through design iterations and tests. IMUs and algorithms have been tested and evaluated for the Orientation Module but are currently under development. An overall system architecture to bring all these modules together for data collection and clinical analysis has been established. A protocol for the testing and validation of the MGAS in the gait lab at Center for the Intrepid has been established and the IRB application submitted. In the following calendar year, tests of the system will determine the accuracy of the results. The data from these results will be used to further improve the system and provide meaningful "clinical data". This clinical data will improve the method in which clinicians personalize prosthetics and train patients while also improving clinical results.					
15. SUBJECT TERMS Motion Analysis, Motion Tracking, Force Sensor, Inertial Measurement Unit, Prosthetics, Wounded Warriors					
16. SECURITY CLASSIFICATION OF:			17. LIMITATION OF ABSTRACT UU	18. NUMBER OF PAGES 77	19a. NAME OF RESPONSIBLE PERSON USAMRMC
a. REPORT U	b. ABSTRACT U	c. THIS PAGE U			19b. TELEPHONE NUMBER (include area code)

Table of Contents

Commonly Used Acronyms and Terms.....	4
Introduction	5
Body	6
Key Research Accomplishments	27
Reportable Outcomes	28
Conclusions	29
References	30
Appendices.....	32

Commonly Used Acronyms and Terms

Ab/Ad	Abduction/Adduction
AP	Anterior/Posterior
CFI	Center for the Intrepid
deg	degrees
F/M	Force/Moment
FEA	Finite Element Analysis
Flex/Ext	Flexion/Extension
g	acceleration due to gravity, equal to 9.81 m/s^2
GRF	Ground Reaction Forces
IMU	Inertial Measurement Unit consists of accelerometers and gyroscopes
Int/Ext	Internal/External Rotation
ISO	International Organization for Standardization
Kinematics	motion of limb segments
Kinetics	external and interactive forces, moments and torques of limb segments during motion
m	meters
MEMS	Microelectromechanical Systems
MGAS	Mobile Gait Analysis System
ML	Medial/Lateral
OB	OttoBock, Inc
ORNL	Oak Ridge National Laboratory
ORP	Office of Research Protection
Pylon	part of the internal structure of the prosthetic device
Pyramid Adapter	adapter which connects the socket to the lower part of the TT prosthetic device and allows for orientation and alignment adjustment
RMSE	Root Mean Squared Error
s	sec
SDK	Software development kit
SI	Superior/Inferior
Socket	The part of the prosthetic device which interfaces with the amputees limb
TT	trans-tibial

Introduction

The goal of this project is to leverage recent advances in motion sensing and microprocessor technology for improving the function and fit of amputee prosthetics as well as providing new, highly accessible and versatile tools for clinicians to use in rehabilitation techniques for amputees. In order to meet these goals, we have evaluated the current state of the art in motion sensing microchips also known as inertial measurement units (IMUs). The latest IMUs typically incorporate microelectromechanical system (MEMS) elements that perform the functions of both a three-axis accelerometer and a three-axis gyroscope. Neither of these devices alone can adequately characterize the motion produced during gait; however, when the signals of both are combined using advanced techniques called sensor fusion algorithms including Kalman filtering and its variants, an accurate measure of motion can be obtained.

In order to measure both the motions (kinematics) and calculate joint and prosthetic interface forces (kinetics), forces must be measured somewhere in the biomechanical system. This is typically accomplished using a floor-mounted force plate in a gait laboratory. In order to make our system compact, portable and versatile, a force/moment (F/M) measuring system which can be mounted under the shoe has been developed along with a F/M-measuring adapter which can be mounted within the a prosthetic device between the socket and prostheses. These sensors measure the kinetics of the affected and unaffected limb in the lower leg amputee. Combining these F/M measurements with cameraless motion capture made possible with IMUs and data fusion algorithm provides a complete picture of patient/subject biomechanics with a system that can be used anywhere.

Although there were some delays as a result of contract negotiations last year and due to the IRB process which delayed collection of data on the first subject at the Center for the Intrepid, we have made a significant amount of progress since the last annual report, especially in the last 6 months. Initial prototypes of the motion and force analysis system were tested on a healthy/control subject at the Center for the Intrepid in August and plans are underway for further patient testing.

The motivation of this research is to help return our highly-trained, professional soldiers to the highest level of activity following injury. The vast majority of servicemen and women undergoing amputation procedures are under 25 years of age [1], and expect to return to an active lifestyle as shown in Figure 1. Other than traumatic amputation, amputation due to vascular disease, primarily diabetes, is performed in the Veterans Health Administration at a rate of 5,000 amputations per year [1], and return to activity following amputation is critical to minimize further disease progression. A soldier's ability to remain active is dependent not only on the prosthetic technology but also on their rehabilitation, training and how well the

prosthetic is “aligned” or “fit” to their unique physiology. The intended application of this system is to improve and streamline the fitting process.

An ill-fitting or misaligned prosthetic can result in asymmetric gait [4,5], which leads to more energy expenditure, injury and chronic conditions in the intact or affected leg [6-8]. Quantitative gait analysis is used in many clinical and research areas [9-18]. But is also be used in the evaluation of prosthetic devices used by patients with amputation of the lower extremity [19-21]. Gait labs, however, are constrained to permanent lab spaces, are not readily available to every clinician or prosthetist, are typically in high demand and expensive. It is our goal for the MGAS to give the prosthetist or clinician instant feedback about patient biomechanics and quality of a prosthetic fit. It will also be useful as a research tool as, with a more affordable and accessible system, more data becomes available to researchers and designers.

Body

Task 1: Establish System Design

Establishing a system design is a combined effort between engineers at Oak Ridge National Laboratory (ORNL) (Oak Ridge, TN, USA), OttoBock Healthcare, Inc. (OB) (Dunderstadt, Germany) and clinicians from the Center for the Intrepid (CFI) at Brooke Army Medical Center at Fort Hood, TX (San Antonio, TX, USA). An initial meeting was held at the Center for the Intrepid February 15, 2011, along with teleconference meetings since that time, regarding the clinical and practical needs for this system. The actual design and production of the system at ORNL has resulted in slight changes to the system design from the original laid out in these 2011 meetings.

1a: Clinical Staff Input: Input from clinicians at CFI has been sought on a continuing basis in order for the MGAS to be clinically useful and successful. Their input is instrumental in ensuring that the MGAS system and all aspects of its use are user friendly and provide clinically relevant data. Our initial focus is on achieving high quality data over making a portable or inexpensive system. There will be two tiers of data, engineering data and clinical data, and one of the challenges for this project is turning the “raw” engineering data into clinically relevant data that is easy to quickly interpret. The system and all of its components should be lightweight and compact. The system needs to be quickly and easily attached to the subject and initialized, and the system should operate on battery power for a minimum of 1 hour. The goal of the software interface design to enhance the existing skillset and instrumentation of the typical prosthetist. The system should also be rugged enough to withstand normal wear and tear and be able to handle average outdoor conditions.

1b: Establish System Specifications:

Overall System:

In order to accurately characterize subject gait motion, the MGAS will have 5 to 8 IMUs. One attached to each body segment including the pelvis, thigh, shank and foot and possibly trunk (Figure 1). Each IMU consists of a three-axis accelerometer and three-axis gyroscope. Each will have a power source, onboard chip to handle data collection, conditioning, storage and wireless communication to the host PC or tablet at 200 Hz. A custom F/M sensor, referred to as a “smart pylon” developed by OB will replace the normal pylon used to adjust a lower leg prosthetic in 6 degrees of freedom. The smart pylon will be able to detect forces and moments in the prosthetic and will have an IMU associated with it, a powersource (battery), data collection, microcontroller and antenna. The F/M foot sensor will detect ground reaction forces (GRFs) in three dimensions on the intact limb and consists of a forefoot and heel sensor. Each force sensor (9 in the forefoot and 7 in the heel) measures forces resulting in 16 channels of 16 bit force data. One IMU will be associated with each the forefoot and heel sensors adding 12 more channels of 16 bit data. The force sensors and foot sensor IMUs will be both powered by the same power source and microcontroller that controls the data acquisition and transmission to the host PC. For the initial prototype, the antenna, battery, IMU and microcontroller will be on an outside package attached to the top of the shoe, however, the goal is to eventually have all of the electronics in the foot sensor package that attaches to the bottom of the foot. The foot sensor unit (including force sensors and foot IMUs) and each segment IMU unit has its own power source, microcontroller, SD memory card and wireless communication. These devices transmit the data over Bluetooth to the host PC or tablet.

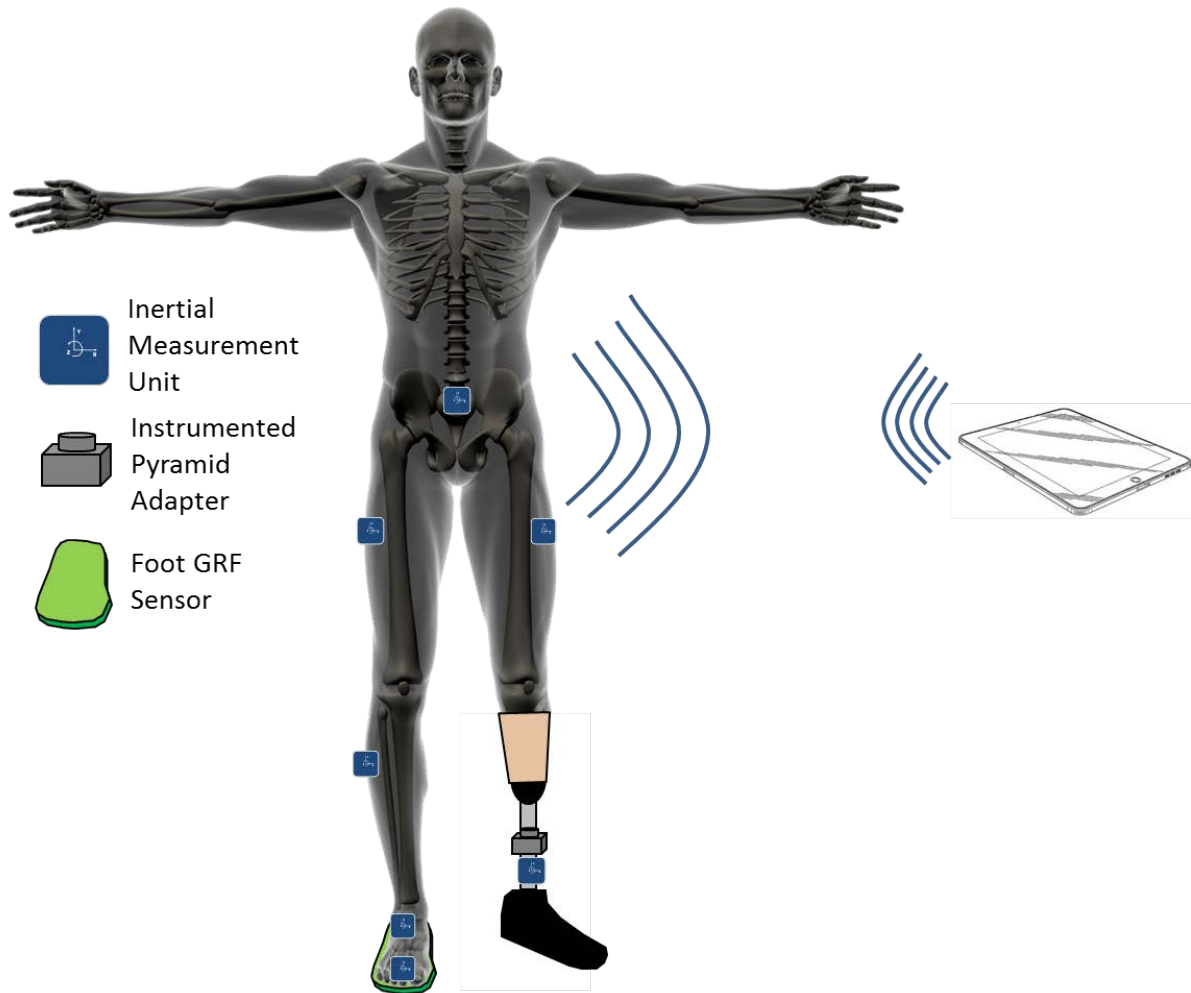

Figure 1: Overall summary of mobile gait analysis system architecture.

IMUs:

Accelerometers: Accelerometers included in IMUs detect acceleration in three axes. In most cases this consists of three single axis accelerometers aligned orthogonal to each other. There are various types and designs of accelerometers. One type is called a dynamic accelerometer which only picks up acceleration associated with movement. Another uses a mass to determine acceleration. This type can detect the direction of gravity. The direction of gravity can be used, along with trigonometry, to determine the pitch and roll orientations of the IMU. We are interested in the angle of limb segments, therefore a mass based accelerometer is needed. MEMS accelerometers have become higher quality and more affordable over the past several years driven by the smart phone and videogame industries. For our application, the accelerometer needs to detect >6 g of acceleration, have low noise and have sufficient resolution, in the mg range.

Gyroscopes: MEMS Gyroscopes are similar to accelerometers in that they generally consist of three uniaxial gyroscopes aligned orthogonally. Gyroscopes detect angular rate and use the Coriolis Effect to detect changes in angle. The gyroscope needs to have sufficient range, between 300 deg/s and 600 deg/s or higher, and have low noise, good stability and high resolution. In order to determine angle from angular rate, integration is necessary. Over time, errant signals can throw the angle measurements off. Also angular walk and drift are a concern resulting in significant errors in angle calculations from gyroscopes over time. Signal conditioning and software algorithms are used to address these issues.

Signal Conditioning and Algorithm: As mentioned earlier, for this device to be beneficial to both researchers and clinicians there will be two levels of data, engineering data and clinical data. Engineering data consists of the data from the IMUs and F/M sensors and also that data transformed into joint angles and joint forces and torques. The software associated with MGAS will take this data and give the clinician information they can use immediately to get more insight into existing prosthesis fit or alignment issues, help in deciding how to adjust a prosthetic or evaluate a prosthetic or fit to decide which is better. Both of these modalities have their individual challenges.

Engineering Data: MEMS IMUs although readily available, inexpensive and relatively good quality still contain substantial noise for the purposes of this project. The data is filtered using a low pass filter (LPF). Although for the initial prototype this will most likely be done in post-processing, the LPF will be applied on board the IMU units and before the data is sent wirelessly to the DCU. To turn the IMU data into joint angle data the LPF filtered data is passed through a Kalman filter [22]. Kalman filters come in various types (traditional, extended, unscented) [23] and the algorithm for this application can be designed in many different ways [24-31]. The Kalman filter takes two noisy signals and combines them using covariance data about the measurement signal, noise and process to get better results than the two signals independently. This is advantageous for us since an errant signal and angular walk associated with gyroscopes can cause errors during integration of the angular rate signals. It can also be challenging to isolate the gravity signals from accelerometers which are also subject to noise. Combining data from accelerometers and gyroscopes with a Kalman filter can provide accurate joint angle results.

Clinical Data: Extracting meaningful clinical data from joint angle data and joint force/torque data requires the application of a second algorithm. This will also involve a GUI which will display this data to the clinician. Development of this algorithm and clinical interface will begin after prototypes are developed and sufficient amounts of patient data are collected.

Initial Position Calibration: The IMUs when initially placed on the lower limbs will not necessarily be aligned with anatomical axes of the limb segments. There will be an offset

between the IMU angle output and the physiological angle. One proposed method to match the IMU orientation to the physiological orientation, uses the Microsoft Kinect® Sensor (Microsoft, Corp., Redmond, WA, USA) which was developed for the Microsoft® X-Box® gaming platform. This sensor costs about \$150 and employs a camera (RGB) and a depth sensor which uses infrared light projected as a grid to detect the depth of an object. The proposed method is that the sensor would quickly determine the location and orientation of IMUs, force sensors and joint centers and axes in the global reference frame (N). If the sensor can accurately determine three points rigidly attached to the sensor in a known configuration, it will be able to determine orientation and location (Figure 2). Once the initial orientation is determined the targets are removed so that only the sensors remain. There is also the option of estimating orientation without targets but this would involve more intensive software development. Properly calibrated, this sensor array has the potential to return three-dimensional positional data of specific points. There are several means of getting the data from the Kinect from a software and communications standpoint.

Microsoft released a software development kit (SDK) for this sensor in June, 2012. The accuracy of the sensor was tested at ORNL over the summer of 2011. Initial tests have found that the accuracy of the Kinect does not meet the requirements to accurately determine 3D position and orientation. Depth error was up to 3 cm and this error increased quadratically with the distance from the sensor. However, additional experimentation is planned and further exploration of using the Kinect sensor is needed. The results from the testing over the summer of 2011 was submitted to the Siemens Math and Science Competition and won first prize for the high school students who did the testing. They share scholarship money of \$100,000 as a reward for their work.

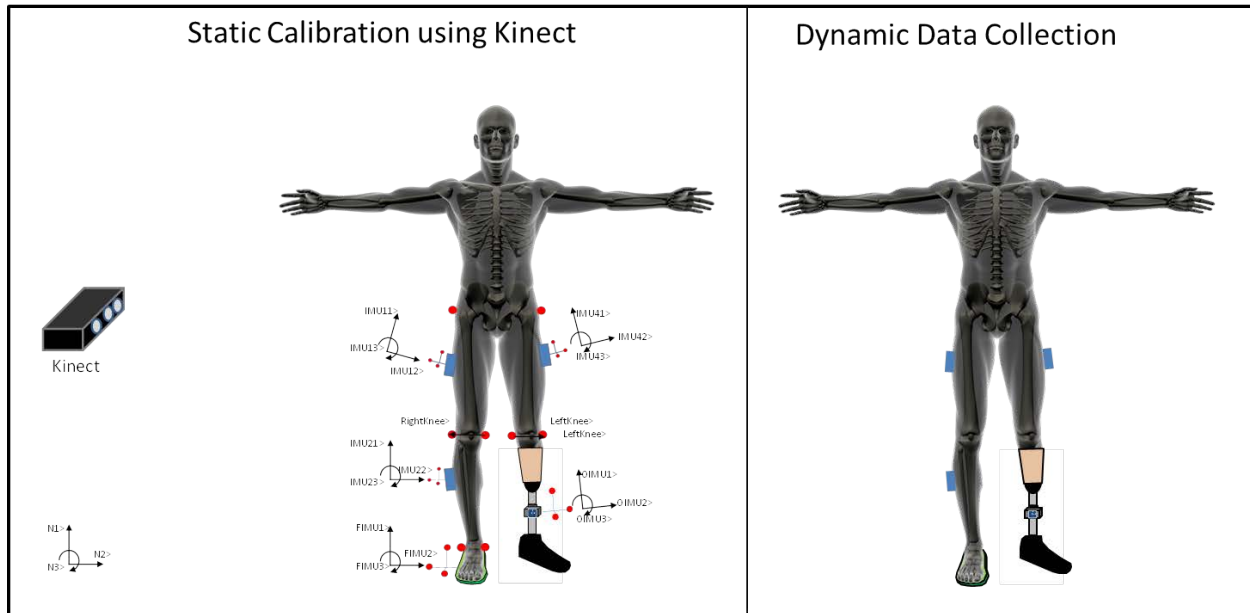

Figure 2: Static calibration using the Microsoft Kinect sensor array (left) utilizing rigidly attached targets on the sensors and markers indicating anatomical landmarks to determine joint axis and center positions. Once static calibration is complete, the targets are removed for dynamic data collection.

A second proposed method to find the initial position of the sensors using a calibration station to assist an optical-based technique with position determination. This method involves a Plexiglas screen with calibration grid laid out on it, and a digital camera connected to a laptop and software (Figure 3). The clinician will put markers on the anatomical landmarks and there will be targets visible on the lateral surface of the IMU sensor cases. The patient will step onto a mat putting the foot sensor in a known location. The clinician then selects the anatomical targets and sensor targets in a specified order. Using the camera data, Plexiglas calibration data, and clinician input data; the software will be able to determine locations of the sensors relative to the foot sensor in the sagittal plane. Data from the static accelerometers is then used to determine the roll and pitch angle of the IMUs. However, yaw (or heading or rotation about the gravity vector) still needs to be determined. Therefore, the patient performs an exercise (abduction/adduction of the hip, flexion/extension of the hip, or walking forward in a straight line) to determine the orientation of the IMUs in the sagittal plane. The patient then either turns around or stops at the mat after the return trip from walking and the process is then repeated for the opposite leg. Initial tests using this method show promise with accuracy in the XY plane (Figure 3) of less than 1 mm under the correct conditions. Further validation, testing and development of this method is needed, however.

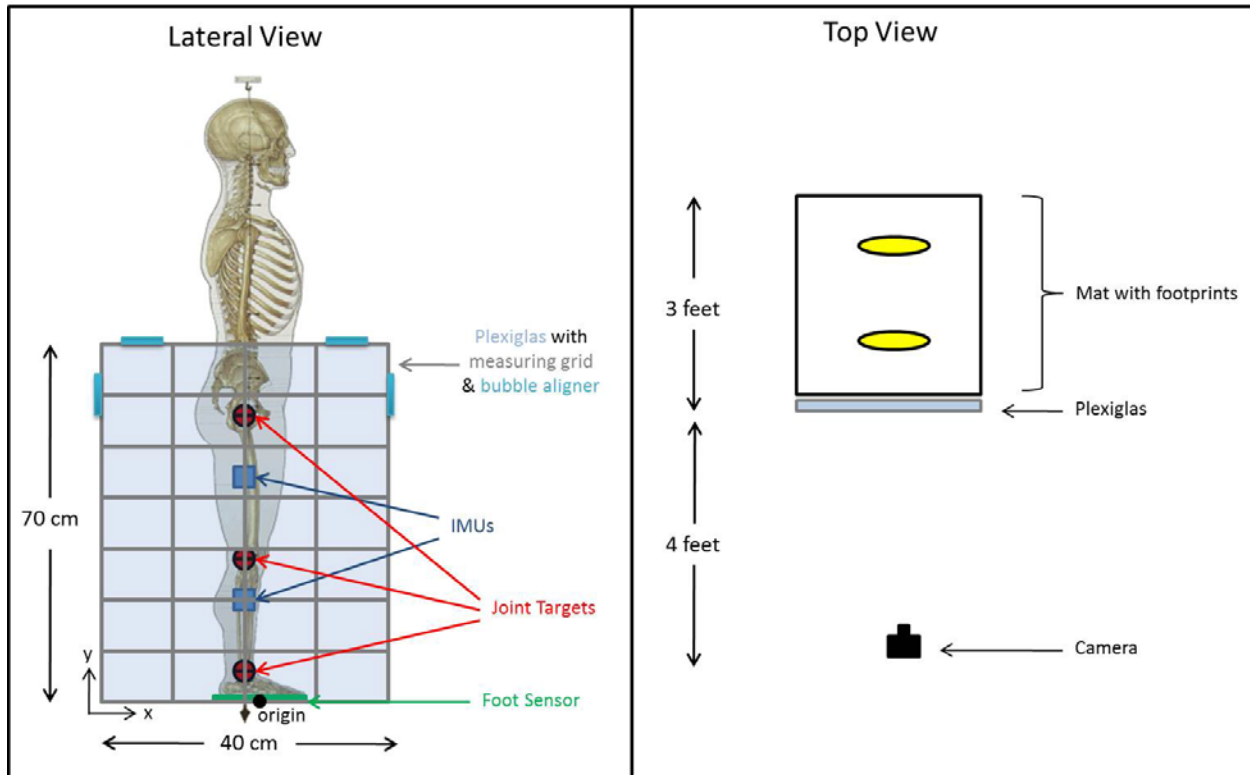

Figure 3: Second calibration method to determine position of IMUs and joint position relative to the foot force sensor in the sagittal plane. To determine orientation, static acceleration data would be used to determine pitch and yaw, however to determine heading a calibration activity needs to be performed.

Smart Pylon Specifications

More information on the design and testing results for the Smart Pylon are shown in Task 5.

- The F/M Sensor shall temporarily replace 4R72=32 Modular adapter (Figure 4)
- Time spent during a clinical fitting, including measurement and action steps based on measurement shall not exceed one hour (as the measurement takes time it must speed up the fitting process to stay within the given time frame).
- In several cases it might be necessary to perform a continuous data acquisition exceeding the fitting time. Therefore the storage capabilities and the power supply should allow for F/M data and inertial sensor data for eight to ten hours.
- Possibilities for the mobile ground reaction force sensor were shared, especially considering the comparison to gait lab and to mobile F/M sensors within a prostheses.



Figure 4: 4R72=32 modular adapter

Foot Sensor:

It was decided that the foot sensor would detect GRF in three directions and contain an IMU in at least the heel section in order to track the sensor orientation relative to the shank and thigh segments. A two component system will be used with one component measuring heel forces and orientation while the second measures forefoot forces. These will communicate wirelessly to the DCU and the data will be used to determine joint torques and moments in the healthy leg. This data along with the smart pylon force data and segment orientation data will be used to determine metrics to determine quality of fit and the adjustments need in a prosthetic to improve performance.

1c: Initial Protocol Development –

The clinicians at CFI have developed an initial protocol for testing the validity of the mobile gait analysis system and this protocol has been approved by their Institutional Review Board (IRB) (See Appendix 3). The testing consists of comparing the MGAS results to the 24 camera optoelectronic motion capture system (Motion Capture, Corp., Santa Rosa, CA, USA) at CFI. Fourteen (14) control subjects, 21 patients and 14 clinicians will be used in the study for data collection and for clinical feedback. The clinicians will be asked to set up/use the mobile gait analysis device and the subjects/patients will perform five trials of three activities, normal walking, stair ascent and 10 degree incline walking. Data will be collected to determine the error of the motion analysis system compared to the 24 camera system but also data will be collected on the clinician feedback.

Task 2: Orientation Module

The orientation module consists of the IMU sensor system used to determine orientation of the limb segments and joint angles.

2a: Orientation Component Selection – The component selection process was described in the 2011 annual report and also in conference proceedings included in Appendix 1. The team selected the Invensense MPU-6000 for the orientation sensor units from several chips tested. This chip was chosen for its size, low power consumption, price, ease of implementation and performance. This chip which costs \$10 and is commercially available. It also performed as well as devices up to 50 times it's cost.

2b: Prototype Electronics and Data – A commercially available computer on module (COM) device was selected. This device runs the Linux operating system and is Bluetooth, WiFi and SD card enabled. The system is open source in that custom expansion boards can be designed to integrate with the COM system. ORNL designed and fabricated an expansion board (Figure 5) for the COM system which includes the IMU chip, USB connectivity, the connectors necessary to connect to and power the F/M foot sensors, battery management and Bluetooth antennae. See Manuscript in Appendix 2 for more details.

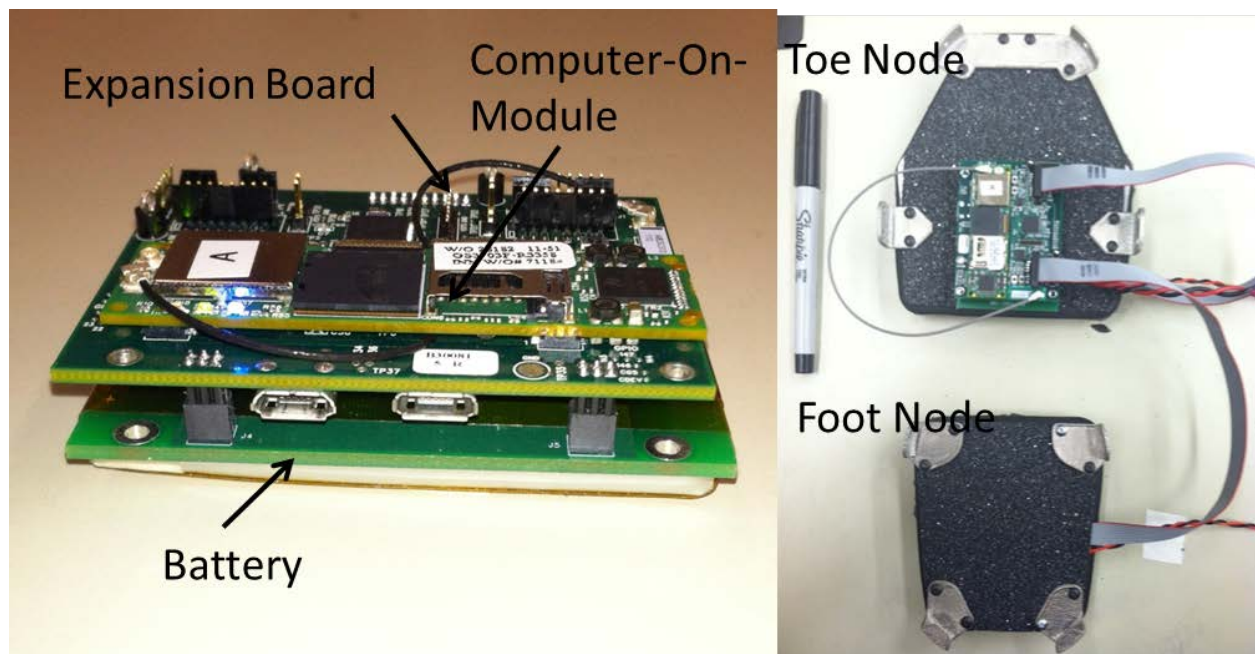

Figure 5: On left is the computer on module device which is commercially available, the expansion and battery boards designed by ORNL. On the right is the sensor board connected to the F/M foot sensor.

2c/2f: Evaluation in Robotics Lab and Results Analysis – The robot was used to evaluate and select different commercially available IMUs, develop the extended Kalman filter (EKF) sensor fusion algorithm and to calibrate the sensors. The robot has proven to be an extremely useful

tool during the development of this system. To evaluate the sensor fusion algorithm, the robot was programmed to move like a human leg using actual biomechanical data collected at CFI. The selected sensor and data fusion algorithm was accurate to within 0.5 degrees root mean squared error (RMSE) during simulated human motion on the robot.

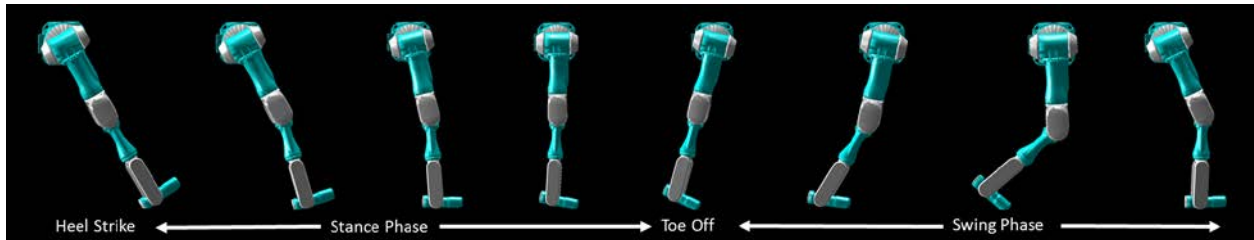

Figure 6: Image sequence of an animation of the robot moving through simulated human walking.

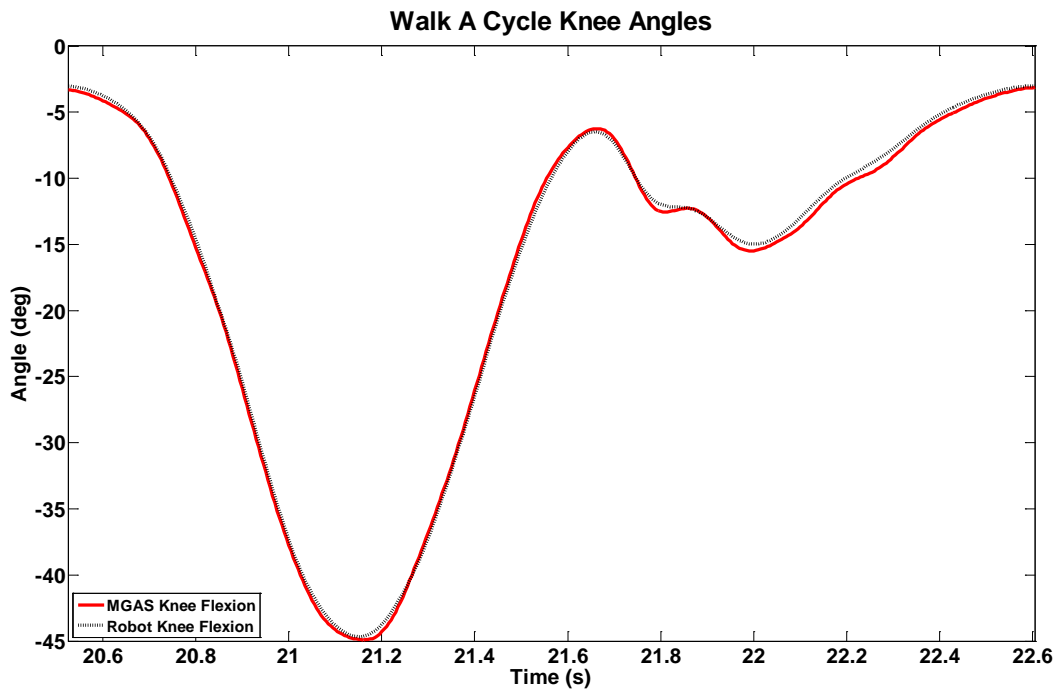

Figure 7: Comparison of knee angle from an example gait cycle from IMU data and sensor fusion algorithm and the actual robot motion according to encoders on the robot.

See manuscripts in Appendix 1 for more details on the IMU selection and initial results from the EKF and Appendix 2 for more details on the more refined EKF and selected IMU.

2d: Sensor Gait Lab Evaluation –The required IRB approval from all sites and subsequent approval from the Office of Research Protection (ORP) was received in the second week of August, 2012 (Appendix 4). This late approval put a significant delay for this project and has put later tasks for CFI and OttoBock behind schedule. During the week of August 27th, two ORNL team members traveled to San Antonio to evaluate the MGAS orientation and force

measurement system against the camera based system at Center for the Intrepid on one healthy subject. The MGAS system test included the shoe force sensor and an IMU sensor on the shank and thigh. Currently the data is being processed. The initial results show that flexion orientations are within 2 degrees RMSE, see Figure 8-Figure 10. The results from the MGAS foot force/moment sensor were within 10% of CFI's gait lab force plate in all three directions (Figure 11).

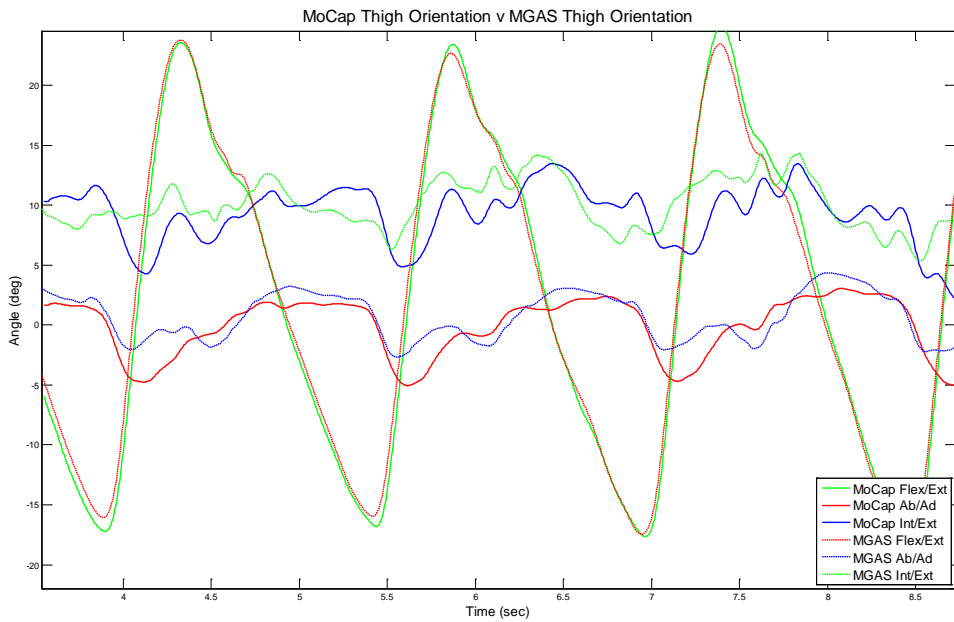

Figure 8: Thigh orientation comparison between the MGAS system currently being developed for this project and the motion capture system (MoCap) at CFI, currently regarded as the gold standard in human motion capture. RMSE value for flexion is 0.9 degrees. (Unpublished data please do not distribute)

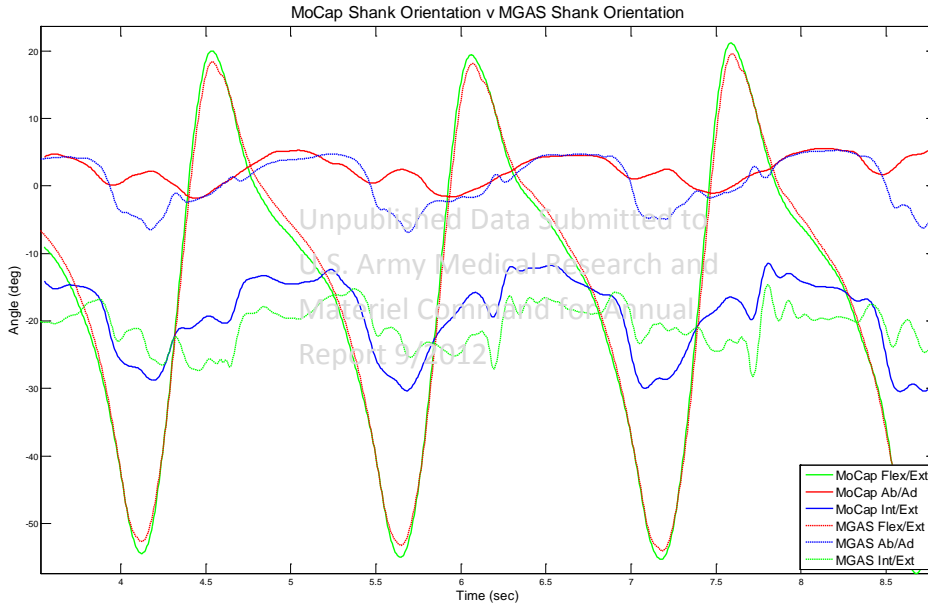

Figure 9: Shank orientation comparison between the MGAS system currently being developed for this project and the motion capture system (MoCap) at CFI. RMSE value for flexion is 1.2 degrees. (Unpublished data please do not distribute)

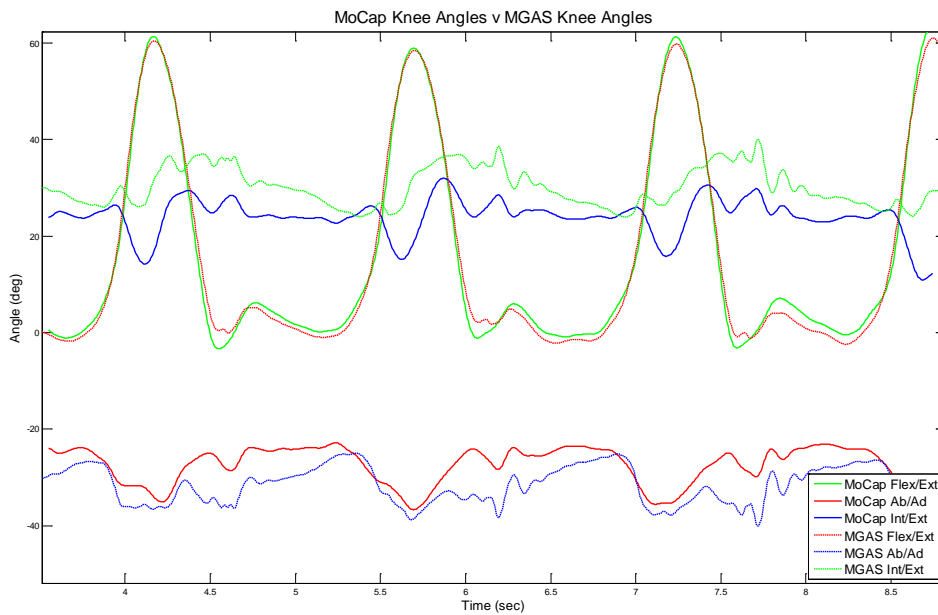

Figure 10: Knee orientation comparison between the MGAS system currently being developed for this project and the motion capture system (MoCap) at CFI. RMSE value for flexion is 1.5 degrees. (Unpublished data please do not distribute)

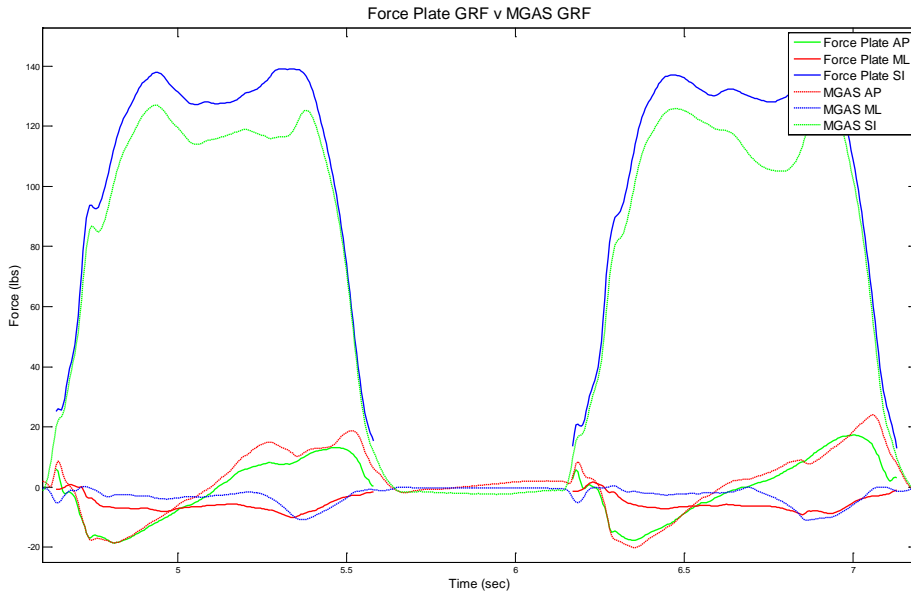

Figure 11: GRF comparison between MGAS foot sensor and the force plate at CFI. (Unpublished data please do not distribute)

2e: Initial System Packaging – The enclosures for the sensor units were designed using Solidworks (Dassault Systèmes SolidWorks Corp. Waltham, MA USA) and printed in plastic on a Dimension Elite 3D rapid manufacturing system (Stratasys Corporation, Eden Prairie, MN, USA). The IMUs were secured to subject segments using Velcro. The boxes may also be secured to an Orthoplast™ (BSN Medical, Hamburg, Germany) substrate that has been molded to fit on the outside of the leg segments and the Orthoplast will be secured to the leg using Velcro and/or athletic tape. The use of the molded Orthoplast™ cast could help reduce the effect of skin artifact on the IMU measurements. Orthoplast was not used during the initial data collection but may be employed in future sessions.



Figure 12: Enclosure and velcro strap for individual sensor boards which go on either the foot or limb segments (right) and enclosure with sensor board connected to the F/M foot sensor attached to the shoe (left).

See Manuscript in Appendix 2 for more details.

Task 3: Wireless Communication

Although other methods were discussed, the team decided on Bluetooth as the wireless protocol since the 2011 annual report. We can now turn system data collection on and off wirelessly and transmit data from each sensor node, however, there is sometimes data dropout which we are still investigating. The data is also stored on the on-board SD memory card incorporated in each sensor. However, our final goal is to transmit all of the data wirelessly. We hope to have data transmission working consistently by the end of the calendar year.

Ottobock is also developing a system which uses Bluetooth communication for both their transtibial Smart Pylon sensor and an inertial orientation sensor system which they are developing concurrently. When testing begins with patients with transtibial prosthetics the data from the system being developed at ORNL and the system being developed at Ottobock will be collected simultaneously.

Task 4: Modification of the Smart Pylon force/moment load measuring system

This task has been performed at OB. Testing consists of iterative design phases with finite element analysis (FEA) and physical testing after each design phase. Ottobock has gone through several iterations to this point and performed the necessary testing. They are now on the latest iteration which will be manufactured in October 2012 and will go through mechanical testing before being tested in human subjects. Task 4a presents a summary of Ottobock's progress toward the smart pylon as of September, 2012.

4a: Modification of Smart Pylon for prosthesis fit, alignment and gait training purposes –

In May the larger, more rugged trans-tibial (TT) Smart Pylon F/M Sensor (Figure 13) was ready for measurements. During validation we found the potential to optimize the calibration test stand and the calibration routine to reduce the error in 3D space to below 3%. This involved changing the calibration test stand so the actuators can apply symmetrical loads from all planes and was mainly achieved by integrating a rotation mechanism (Figure 14). So now we calibrate in 3 different rotation positions of the coordinate system – 0°, 90° and 45°.

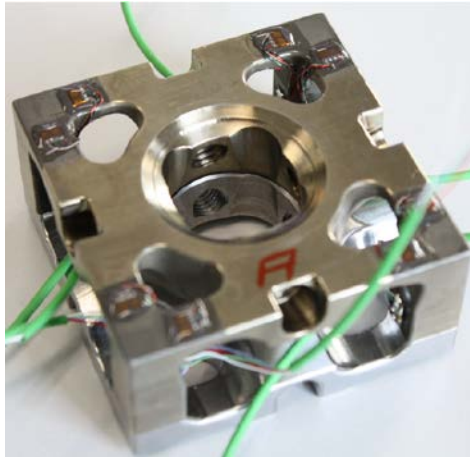

Figure 13: Large TT Smart Pylon adapter instrumented with strain gauges.

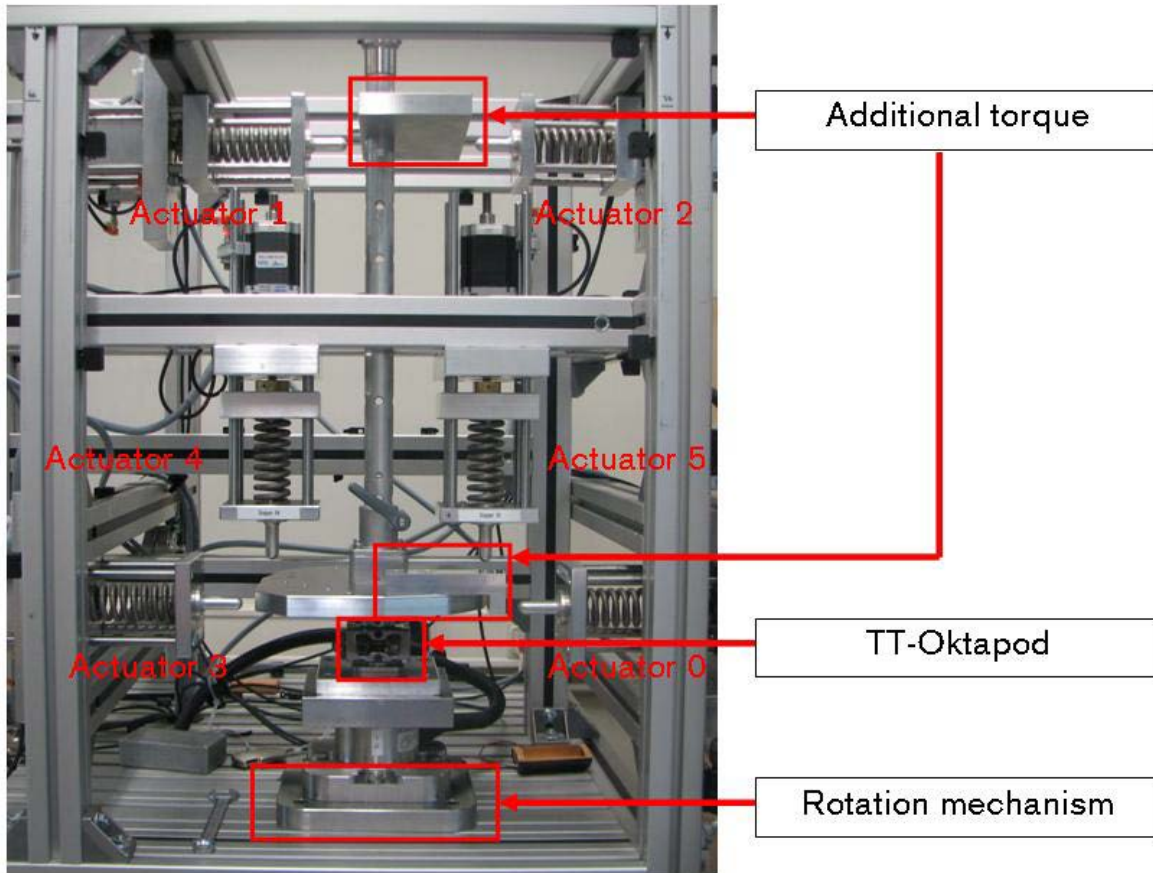

Figure 14: Calibration test stand used to calibrate the Smart Pylon.

Reduction in size and weight of F/M sensor

Having responsibility for the design of the F/M Sensor with the capability to acquire six degree of freedom loadings during use of a prosthetic device, Ottobock took on the challenge to significantly increase the load capacity of the unit while keeping the size and weight within reasonable limits. After relatively promising early work based on a monolithic design approach, the initial positive results unfortunately could not be reliably duplicated. As a fallback solution the existing larger and heavier F/M Sensor demonstrates enough strength and is equipped with strain gauges and signal conditioning. However, it is expected that the weight and size of the heavier unit may unduly influence the patient's activity, so we believe a lighter and smaller design that is robust, reliable and reproducible is still a necessity to commence measurements with subjects.

Three different promising designs have been fabricated and physically tested. The design concept of four independent frames around the modular adapting pyramid receivers is still the focus, but the connecting area of the frames to the pyramid receiving rings has been varied significantly to achieve the required strength. The various designs all showed independent

sources of failures in the lab tests prior to reaching the goal of 3 million cycles, so alternative design strategies were followed up. In addition to the strength requirement, the strain based load measurements require adequate deflection, so a very precisely balanced design for the physical structure is required. The latest result (Figure 15) of this iterative design process can be seen in the adaptation to a “central bar connector”. The final balancing of the bearing bars is currently undergoing FEA analysis, and in October 2012 the optimized design will be manufactured and structurally tested.

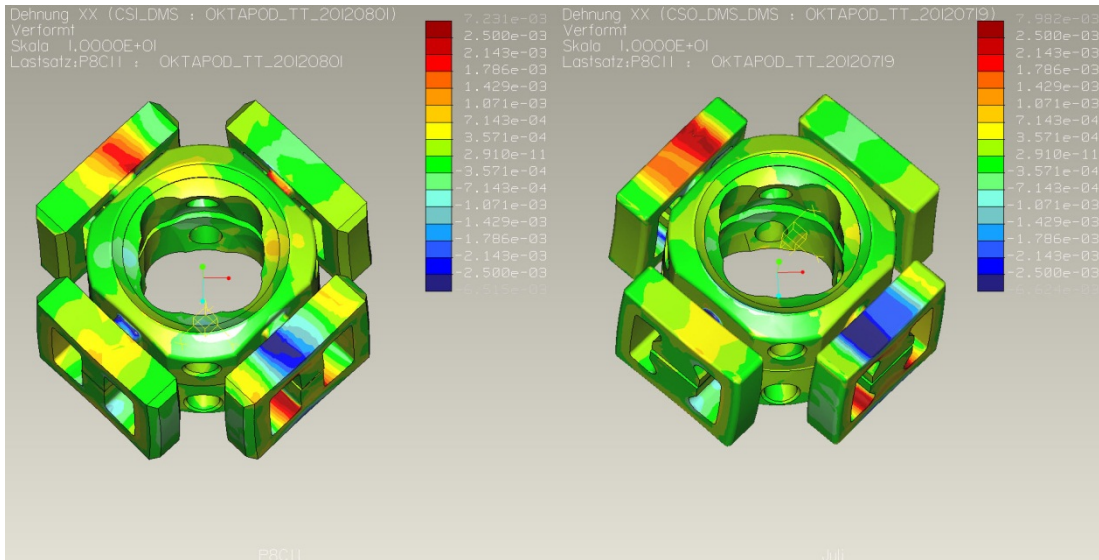

Figure 15: FEA testing of latest Smart Pylon design.

4b/4c: Integration of orientation measuring system from Task 2 and Wireless Data transmission system – Ottobock has designed a Bluetooth enabled orientation measurement system and will incorporate the data from the “smart pylon” device into it.

Task 5: Prosthetic component design safety

Task 5 is being conducted by Otto Bock in conjunction with Task 4.

5a: FEA modeling of design: FEA modeling is incorporated throughout the iterative design process for this device. The latest design has gone through FEA analysis and will be tested in laboratory settings in October, 2012. See Task 4a.

5b: Mechanical testing: As the ISO 10328 standard is based on the regular use of the tested components, the extraordinary loading conditions of the highly trained professional soldiers are covered by temporarily restricting the maximum bodyweight of the users to 100kg, whereas the device is tested to 175kg. Real data acquired under these conditions will allow the team to determine the basic constraints for a final design capable of performing data acquisition for

soldiers of higher body weight. As the F/M sensor is driven with low voltage the mechanical risk is the only one at present which is covered by the structural strength test of ISO 10328.

Five of the large TT Smart Pylon F/M sensors were assembled and tested (Figure 16). These results were detailed in the 2011 Annual Report for this project. Currently, as described in Task 4, the lessons learned from these tests have been incorporated into newer versions of the large Smart Pylon and the design of the smaller, optimized pylon. This smaller optimized design will be manufactured and tested in October 2012.



Figure 16: Test setup for smart pylon F/M sensors

Task 6: Mobile Ground Reaction Force Sensor

6a: Overall Design Requirements –

- It was decided that the F/M foot GRF sensor for the healthy leg must be able to detect forces and moments in all three six axes.
- There will be a sensor for both the forefoot and heel.
- The sensor must be lightweight and less than a half inch thick so as not to affect the movement or gait patterns of the subject.
- The goal is that the design will have enough room in the underfoot module for electronics including an IMU, wireless transmission hardware and power source.
- For initial designs, it is satisfactory for some of the electronics to be worn on the shoe.
- The sensor will be environmentally sealed to prevent damage from normal amounts of wear and environmental/weather conditions.

- Desirable to be able to modularly swap out components (strain gauges, load cells, IMU) in case one fails.

6b: Load Cell Detailed Design – The foot F/M sensor was designed at ORNL.

- The forefoot and heel sensors were designed in such a way that the vertical and shear forces could be isolated without the measurement of one loading mode affecting another.
- Designed to follow the shape of the sole of a size 10 1/2 athletic shoe with guides to limit slip between the sensor and the shoe sole. The sensors are 12 mm thick and the forefoot and heel sensors weigh ~170 grams and ~120 grams, respectively which falls within what was deemed reasonable not to affect the gait patterns of subjects. Some additional height is added for environmental sealing and to provide a high friction contact with the ground.
- Design was optimized to allow for the most room possible for electronics and power supply

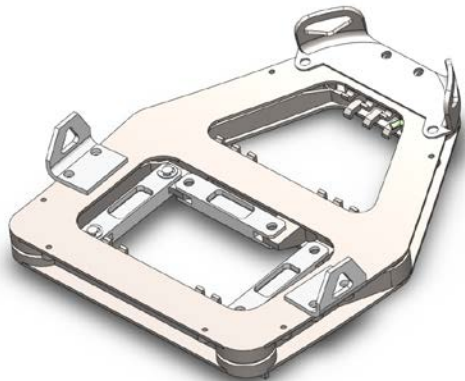

Figure 17: Forefoot sensor design, ~170 g, 12mm high

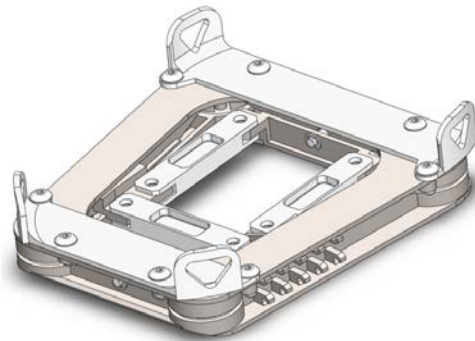

Figure 18: Heel sensor, ~120g and 12mm added height

6c: Footwear attachment system – An initial attachment system was developed using nylon straps. The attachment system works similar to the bindings found on crampons worn by mountaineers. This system was tested at CFI with a healthy/control subject and was comfortable for the subject. It is hard to determine if the sensors moved relative to the shoe. We were not able to measure relative motion between the sensor and the shoe, however based on our observations and the subjects perception, relative motion was minimal or nonexistent. Also, following data collection and analysis the sensors appeared to be in the same orientation relative to the shoe after the data collection session.



Figure 19: Binding system for force sensor to shoe. A “dummy” sensor made of plastic was also produced to provide symmetry to the other foot for the normal subjects.

6d/6f: Signal Conditioning and Electronics and Data Acquisition System – See Manuscript in Appendix 2.

6e/6g: Prototype fabrication - Prototypes of both sensors have been fabricated using a titanium rapid prototyping process (Figure 20 and Figure 21). Environmental sealing, electronics integration, cabling and shoe attachment method (6c) have been fabricated and tested. All design criteria outlined in 6a and 6b were met. Initial testing of the shoe sensor against an embedded force plate has been performed with more testing and data collection planned by the end of the calendar year.

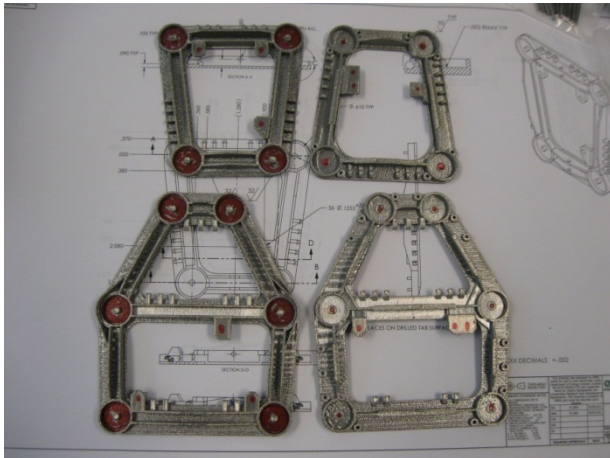

Figure 20: Prototypes of the heel (top) and forefoot (bottom) force sensor housings.

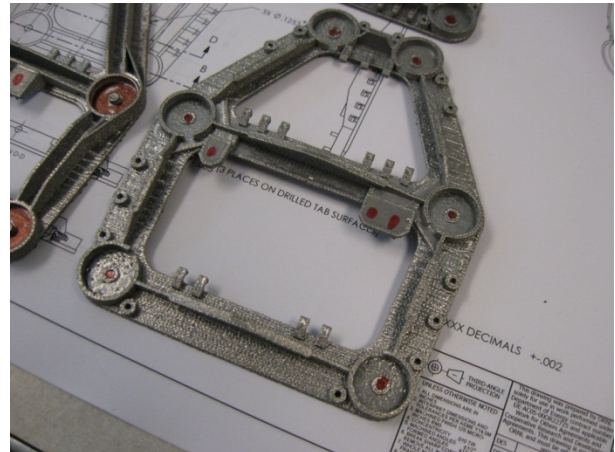

Figure 21: Close up of one of the two halves of the forefoot sensor housing.

Task 7: Software interface development

Software has been developed to post-process the data stored on the SD cards at each sensor node or the data transmitted via Bluetooth. Currently a GUI which can start and stop the data collection and display

real time data channels including IMU and force data has been developed. The interface will continue to be developed. As more of the algorithm and software including the extended Kalman filter is embedded into the hardware, the software will be a window into what is being measured and calculated on the device. This will be a focus of the team once the system is validated, then clinical feedback from clinicians will be crucial to make an interface that is intuitive, powerful and displays meaningful data that will have immediate clinical impact.

Task 8: Evaluation of prototype device during clinical assessment/training

Data collection was performed on a healthy/control subject the week of August 27th. More data collection on healthy/control subjects will be scheduled before the end of the calendar year. Data collection on amputee subjects will begin in the late 2012 or early 2013 calendar year. This evaluation will be used to improve the accuracy of the results from the MGAS system compared to camera based biomechanical analysis systems. The evaluation also involves feedback from clinicians on the ease of use and validity of incorporating this system in their day to day practice.

Task 9: Develop activity performance criteria

The activities best performed to garner clinically meaningful data will be determined as the prototype is tested and data analyzed. Currently the activities that will be measured are overground walking at various speeds, incline walking and stair climbing.

Task 10: Optimization of system durability for clinical implementation

As problems arise during testing and during use in the “clinical” environment these adjustments will be made.

Task 11: Collection of activity data using multiple alignment configurations with comparison to optoelectric (camera based) motion capture system

This will be performed once all healthy/control subject data has been collected and the prototype system which meets the demands of the clinician is completed. Sometime early 2013 calendar year.

Task 12: Use data to determine metrics to indicate positive patient biomechanics factors and indicate successful prosthesis fit and alignment

This will be performed using data collected in Task 11.

Task 13: Develop 4 fully functional units

This task will begin once Task 1 through Task 12 are completed.

Task 14: Reintroduce final system in clinic

After Task 13

Task 15: Direct use in patient setup and alignment for multiple patients

This will occur concurrently with Task 14.

Key Research Accomplishments

- The system requirements and an initial system architecture for the MGAS has been established.
- Testing of different IMU units has been performed to determine sensor and signal quality and efficacy in determining joint angles.
- Algorithms to calculate joint angles from acceleration and angular rate signals from IMUs have been developed. This will be an ongoing process but with current methods, the system provides an accuracy compared to the gold standard motion analysis methods of better than 2 degrees RMSE.
- Design iterations and testing of the “smart pylon” have been completed
- The design of the foot sensor prototype mechanical and electronic components has been completed and fabrication of device and associated electronics completed.
- Data acquisition and wireless transmission devices and software have been designed, fabricated, implemented and tested during data collection at Center for the Intrepid.
- A protocol for the testing and validation of the MGAS system has been established and the IRB approved.
- A healthy/control subject has been evaluated using both the camera based motion capture and MGAS motion capture. The data is currently being processed, however, initial results show accuracy of better than 2 degrees RMSE and consistent and accurate force measurements. Data collection on more patients will be scheduled later this calendar year.

Reportable Outcomes

- One post-doc, three Science Undergraduate Laboratory Internship (SULI) positions and a project which won first prize in the Siemens Competition in Math, Science and Technology by two Oak Ridge High School (Oak Ridge, TN) students has been supported as a result of this grant.
- A paper was presented at the 2nd Annual Future of Instrumentation International Workshop November 7-8, 2011 (Appendix 1).
<http://www.ornl.gov/sci/ees/mssed/futureinstruments/index.shtml>
- A podium presentation was made at MHSRS August 13-16, 2012 and a manuscript submitted which, if accepted, will be published in Military Medicine (See Appendix 2).
<https://www.atacc.org/>

Conclusions

Significant progress has been made on the Mobile Gait Analysis System in the last year. The majority of the prototype electronics hardware and software is completed along with wireless data transmission protocols. Data has been collected from one healthy/control subject at Center for the Intrepid and data is currently being process from that trip and algorithms and software being optimized for future data collection. Future collection of subject date will be scheduled for October/ November of 2012. Significiant delays for data collection were the result of delays in the IRB and ORP approval process. The delay in data collection has put OttoBock and CFI significantly behind schedule for some of this project's milestones. To complete all of the tasks in the approved SOW, it is anticipated that an extension of the project timeline of one year will be requested.

References

1. Gawande A. Notes of a Surgeon Casualties of War — Military Care for the Wounded from Iraq and Afghanistan. *N Engl J Med.* 2004 351;24. 2473-2475.
2. Mayfield JA, Reiber GE, Maynard C, Czerniecki JM, Caps MT, Sangeorzan BJ. Survival following lower-limb amputation in a veteran population. *Journal of Rehabilitation Research and Development.* May/June 2001. (38) 3. 341–345.
3. U.S. Department of Health and Human Services, AHRQ, Agency for Healthcare Research and Quality. National Healthcare Quality Report, 2007. <http://www.ahrq.gov/qual/nhqr07/Chap2.htm>. Accessed Oct. 7, 2008.
4. Reiber GE. Who Is At Risk of Limb Loss And What To Do About It? *Journal of Rehabilitation Research and Development.* Nov. 1994. (31) 4. 357-362.
5. Schmalz T, Blumentritt S, Jarasch R. Energy expenditure and biomechanical characteristics of lower limb amputee gait: the influence of prosthetic alignment and different prosthetic components. *Gait Posture.* 2002 Dec;16(3):255-63.
6. Schmalz T, Blumentritt S, Jarasch R. Energy expenditure and biomechanical characteristics of lower limb amputee gait: the influence of prosthetic alignment and different prosthetic components. *Gait Posture.* 2007 Feb;25(2):267-78.
7. Kulkarni J, Gaine WJ, Buckley JG, Rankine JJ, Adams J. Chronic low back pain in traumatic lower limb amputees. *Clin Rehabil.* 2005. Jan;19(1):81-6. Kulkarni J, Adams J, Thomas E, Silman A. Association between amputation, arthritis and osteopenia in British male war veterans with major lower limb amputations. *Clin Rehabil.* 1998 Aug;12(4):348-53.
8. Nolan L, Wit A, Dudzinski K, Lees A, Lake M, Wychowanski. Adjustments in gait symmetry with walking speed in trans-femoral and trans-tibial amputees. *Gait and Posture.* 2003. 17: 142-151.
9. Vickers DR, Palk C, McIntosh AS, Beatty KT. Elderly unilateral transtibial amputee gait on an inclined walkway: A biomechanical analysis, *Gait & Posture.* 2007, doi:10.1016/j.gaitpost.2007.06.08.
10. Miff SC, Childress DS, Gard SA, Meier MR, Hansen AH. Temporal symmetries during gait initiation and termination in nondisabled ambulators and in people with unilateral transtibial limb loss. *J. Rehab. Res. and Dev.* 2005;42 (2), 175-182.
11. Quesada PM, Pitkin M, Colvin J. Biomechanical Evaluation of a Prototype Foot/Ankle Prosthesis. *IEEE Trans. on Rehab. Eng.* 2000;8(1), 156-159.
12. Buckley JG, ODriscoll D, Bennett SJ. Postural Sway and Active Balance Performance in Highly Active Lower-Limb Amputees. *Am. J. Physical Medicine and Rehabilitation.* 2002;81(1), 13-20.
13. Schmalz T, Blumentritt, Marx B. Biomechanical analysis of stair ambulation in lower limb amputees. *Gait & Posture.* 2007;25, 267-278.
14. Gard SA. Use of Quantitative Gait Analysis for the Evaluation of Prosthetic Walking Performance. *J. Prosthetics and Orthotics.* 2006;18(1S) 93.
15. Hofstad CJ, van der Linde H, Nienhuis B, Eng M, Weerdesteyn V, Duysens J, Geurts AC. High Failure Rates When Avoiding Obstacles During Treadmill Walking in Patients With a Transtibial Amputation. *Arch Phys Med Rehabil.* 2006;87, 1115-1122.
16. Ebrahimzadeh MH, Rajabie MT. Long-term Outcomes of Patients Undergoing War-related Amputations of the Foot and Ankle. *J Foot Ankle Surg.* 2007;46(6), 429-433.
17. Dennis DA, Komistek RD, Mahfouz MR, Outten JT, Sharma A. Mobile-bearing total knee arthroplasty: do the polyethylene bearings rotate? *Clin Orthop Relat Res.* 2005;440, 88-95.

18. Han TR, Chung SG, Hi S. Gait Patterns of Transtibial Amputee Patients Walking Indoors Barefoot. *Am J Phys Med Rehabil.* 2003;82(2), 96-100.
19. Dou P, Jia X, Suo S, Wang R, Zhang M. Pressure distribution at the stump/socket interface in transtibial amputees during walking on stairs, slope and non-flat road. *Clinical Biomechanics.* 2006;21, 1067-1073.
20. Segal AD, Orendurff MS, Klute GK, McDowell ML, Pecoraro JA, Shofer J, Czerniecki JM. Kinematic and kinetic comparisons of transfemoral amputee gait using C-Leg and Mauch SNS prosthetic knees. *J. of Rehabil Res and Dev.* 2006: 43(7), 857-870.
21. Lee WCC, Zhang M, Chan PPY, Boone DA. Gait Analysis of Low-Cost Flexible-Shank Transtibial Prosthesis. *IEEE Trans on Neural Systems and Rehabilitation Engineering.* 2006: 14(3), 370-377.
22. Kalman, R.E. A new Approach to linear filtering and prediction problems. *Journal of Basic Engineering.* 1960: 82 (Series D), 35-45.
23. Cui, C.K., Chen, G., 1999. *Kalman Filtering: with Real Time Applications*, 3rd ed. Springer, Berlin, Germany.
24. Favre, J., et al.,. Ambulatory measurement of 3D knee joint angle. *Journal of Biomechanics.* 2008: 41 (5), 1029–1035.
25. Luinge, H.J., Veltink, P.H.. Measuring orientation of human body segments using miniature gyroscopes and accelerometers. *Medical and Biological Engineering and Computing.* 2005: 43 (2), 273–282.
26. Favre, J., et al. Quaternion-based fusion of gyroscopes and accelerometers to improve 3D angle measurement. *Electronics Letters.* 2006: 42 (11), 612–614.
27. Boonstra, M.C., et al. The accuracy of measuring the kinematics of rising from a chair with accelerometers and gyroscopes. *Journal of Biomechanics.* 2006: 39, 354–358.
28. Kavanagh, J.J., Menz, H.B. Accelerometry: a technique for quantifying movement patterns during walking. *Gait Posture.* 2008: 28 (1), 1–15.
29. Cutti AG, Giovanardi A, Rocchi L et al. Ambulatory measurement of shoulder and elbow kinematics through inertial and magnetic sensors. *Med Biol Eng Comput.* 2008: 46(2), 169–178
30. O'Donovan KJ, Kamnik R, O'Keeffe DT et al. An inertial and magnetic sensor based technique for joint angle measurement. *J Biomech.* 2007: 40,2604–2611
31. Cooper, G., Sheret, I., McMillian, L., Siliverdis, K., Sha, N., Hodgins, D., Kenney, L., Howard, D. Inertial sensor-based knee flexion/extension angle estimation. *J. Biomech.* 2009: 42, 1678-1685.

Appendix 1: Manuscript submitted to FIIW 2011

A Mobile Motion Analysis System Using Inertial Sensors for Analysis of Lower Limb Prosthetics

John Kyle P. Mueller, Boyd M. Evans, III, M. Nance Ericson, Ethan Farquhar, Randall Lind
Measurement Science and Systems Engineering Division
Oak Ridge National Laboratory
Oak Ridge, TN, USA
muellerjp@ornl.gov

Kevin Kelley, Martin Pusch, Timo Von Marcard
Otto Bock Healthcare Products
Dunderstadt, Germany

Jason M. Wilken
Military Performance Lab
Center for the Intrepid-Brooke Army Medical Center
Fort Sam Houston, TX

Abstract— Soldiers returning from the global war on terror requiring lower leg prosthetics generally have different concerns and requirements than the typical lower leg amputee. These subjects are usually young, wish to remain active and often desire to return to active military duty. As such, they demand higher performance from their prosthetics, but are at risk for chronic injury and joint conditions in their unaffected limb. Motion analysis is a valuable tool in assessing the performance of new and existing prosthetic technologies as well as the methods in fitting these devices to both maximize performance and minimize risk of injury for the individual soldier. We are developing a mobile, low-cost motion analysis system using inertial measurement units (IMUs) and two custom force sensors that detect ground reaction forces and moments on both the unaffected limb and prosthesis. IMUs were tested on a robot programmed to simulate human gait motion. An algorithm which uses a kinematic model of the robot and an extended Kalman filter (EKF) was used to convert the rates and accelerations from the gyro and accelerometer into joint angles. Compared to encoder data from the robot, which was considered the ground truth in this experiment, the inertial measurement system had a RMSE of <1.0 degree. Collecting kinematic and kinetic data without the restrictions and expense of a motion analysis lab could help researchers, designers and prosthetists advance prosthesis technology and customize devices for individuals. Ultimately, these improvements will result in better prosthetic performance for the military population.

Keywords - Prosthetic, Motion Analysis, Inertial Measurement Unit, Ground Reaction Force Sensor

I. INTRODUCTION

Since the global war on terror began 10 years ago, the United States military has made great strides in how it treats

wounded soldiers on the battlefield as well as in the hours and days following a soldier's injury. Although this has resulted in a decrease in mortality among the wounded, it has left thousands of soldiers and veterans with conditions like lower leg amputations which require long term care. Before their injuries, lower leg amputees in the military population were young, athletic and in top physical condition [1]. For this reason, most military patients want to remain active and in some cases return to active military duty. The likelihood of these patients returning to an active lifestyle for an extended period of time is dependent upon prosthesis fit and function, and the patient's acclimation to the device. One symptom of an ill-fitting or poorly functioning prosthetic device is asymmetric gait [2]. Asymmetric gait over extended periods of time can contribute to the development of overuse injury and chronic conditions like arthritis in the patient's healthy leg. One method for quantifying movement asymmetries and its effect on joint kinematics and kinetics is computerized motion analysis. In general, motion analysis requires access to gait labs which require a large open space. These facilities are not readily available, are expensive and are in high demand. The fitting of a prosthesis is also an iterative and ongoing process which means multiple gait lab analyses are needed to get the best results. It also requires patient testing be performed in a controlled lab environment, which may not represent normal performance of daily activities. Our objective is to develop a relatively inexpensive, portable, camera-less, motion analysis system using portable force sensors and inertial measurement units (IMUs) that can give prosthetists or therapists instant biomechanical information and feedback regarding prosthetic performance and fit on individual soldiers.

II. MATERIALS AND METHODS

A. Robot Testing

A Mitsubishi Heavy Industry (Tokyo, Japan) PA-107C robot arm was employed for testing different prepackaged IMUs. Initial tests using a calibrated digital level showed that the encoder (joint angle) data from the robot was accurate to

Funding provided by Department of Defense Congressionally Directed Medical Research Programs Funding Opportunity Number: W81XWH-09-PRORP-TDA

Oak Ridge National Laboratory (ORNL) is managed by UT Battelle, LLC for the U. S. Department of Energy under Contract No. DE-AC05-00OR22725.

within 0.2 degrees. The IMU system is intended to attain accuracy within one degree, therefore the encoder data is used as the gold standard in this experiment. The robot was run through repeatable motions several times while simultaneously recording the encoder data from the robot with the gyroscope and accelerometer data from the IMUs (Fig. 1).

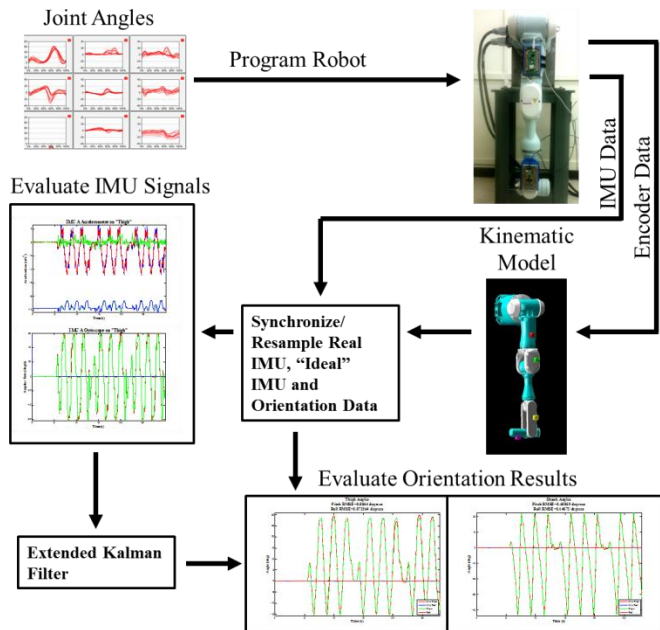

Figure 1: Flow chart describing the methods in this study including taking data from gait analysis to program the robot and using the encoder data to evaluate IMU and EKF results.

The robot was programmed to simulate the motion of a human leg using joint angle data from gait analyses of a healthy subject. Since the human leg has nine rotational degrees of freedom (DOF) including the hip, knee and ankle while the robot can only represent six, three DOF are excluded. The angles represented by the robot included hip flexion/extension, hip abduction/adduction, knee flexion/extension, knee abduction/adduction, knee internal/external rotation and foot flexion/extension. For this study the IMUs were tested with the robot only articulating at the hip and knee in flexion/extension (2D Gait). An IMU was attached to the “thigh” and “shank” segments of the robot. The goal was to determine the orientation of the segments and the angle between them, or the “knee” angle (no IMU was placed on the “foot” in tests presented here).

IMUs were attached to the robot segments using custom holders designed to put the IMUs in the same place for each trial (Fig. 1). The positions of the IMUs relative to the robot segments, needed for the kinematic model, were measured by hand.

B. Kinematic Model and IMU Signals

A kinematic model of the PA-10 was created (Fig. 1). The position and orientation of the IMUs relative to the robot segments, the robot joint angle data, and the robot segment lengths were the inputs for the model. The outputs were the position and orientation of the IMUs as well as calculated

accelerometer and gyroscope “signals” used as the ground truth when determining the accuracy of the IMU signals. The calculated IMU data was used to synchronize IMUs, evaluate IMU performance and develop the algorithm used to calculate joint angles from IMU data (Fig. 1).

Two IMUs from leading manufacturers, IMU A and IMU B, which included three axis accelerometers and gyroscopes were tested. IMU A was designed for commercial/industrial use and IMU B was designed for consumer use (phones and video game controllers). The sensors were calibrated using the manufacturer provided software and instructions. Any signal conditioning, including filtering, was left at the default settings. The joint position signals from the robot and the IMU signals were simultaneously collected during the trials. IMU A was sampled at 167 Hz and IMU B at 187 Hz. To easily compare and work with data from two asynchronous systems, the data from the kinematic model and both types of IMUs were synchronized and resampled at 150 Hz using linear interpolation, resulting in easily comparable, synchronized data sets.

C. Algorithm to Determine Joint Angles

Segment (robotic “shank” and “thigh”) pitch and roll angles were calculated by estimating the direction of gravity using the accelerometer signals. The gyroscope signals can be integrated to determine pitch, roll and yaw (heading). However, these calculations are subject to drift and noise which cause increasing error as the signal is integrated over time. Individually, these respective angle calculations are inaccurate.

An extended Kalman filter (EKF) [3] was developed to fuse the accelerometer and gyroscope data. The method is a modification of an algorithm presented in Cooper et al. [4]. The filter used a 14-element state vector (1)

$$x = \begin{bmatrix} v_{int} \\ a_{int} \\ \omega_{body} \\ b_{gyr} \\ r \\ p \end{bmatrix} \quad (1)$$

where v_{int} and a_{int} are velocity and acceleration in three axes transformed to an intermediate reference frame, ω_{IMU} and b_{gyr} are the gyroscope signals and the gyroscope bias in three axes, and r and p are roll and pitch of the segment. The intermediate reference frame is initially aligned with the laboratory reference frame but rotates about the gravity vector and is propagated outside of the EKF. The rotations from the laboratory frame to the IMU frames are represented using direction cosine matrices so pitch and roll rotations can be isolated while rotations about the gravity vector are ignored.

The velocity at step $k+1$, in the intermediate frame are found by numerically integrating a_{int} (2) over timestep Δt .

$$v_{\text{int},k+1} = v_{\text{int},k} + a_{\text{int},k} \Delta t. \quad (2)$$

Accelerations, angular rates and angular biases are modeled by using the value at the previous time step, adding noise, w^a, w^ω, w^{gyr} to acceleration, gyroscopes and bias and, for the acceleration model subtracting a factor multiplied by velocity, γv_p , to stabilize the velocity calculation (3)

$$\begin{aligned} a_{\text{int},k+1} &= a_{\text{int},k} + w_k^a - \gamma v_{p,k} \\ w_{\text{body},k+1} &= \omega_{\text{body},k} + w_k^\omega \\ b_{\text{gyr},k+1} &= b_{\text{gyr},k} + w_k^{gyr} \end{aligned} \quad (3)$$

Angles of the segments in the lab frame were calculated by transforming the gyroscope signals to the lab frame (4)

$$\begin{aligned} \dot{r} &= \omega_x + (\omega_z \cos r + \omega_y \sin r) \tan p \\ \dot{p} &= (\omega_y \cos r - \omega_z \sin r) \\ \dot{y} &= (\omega_z \cos r + \omega_y \sin r) \sec p \end{aligned} \quad (4)$$

representing the time derivative of roll, pitch and yaw, \dot{r}, \dot{p} and \dot{y} , then numerically integrating the angular velocities (5)

$$\begin{aligned} r_{k+1} &= r_k + \dot{r}_k \Delta t \\ p_{k+1} &= p_k + \dot{p}_k \Delta t \\ y_{k+1} &= y_k + \dot{y}_k \Delta t \end{aligned} \quad (5)$$

Here, y is yaw, which is not included in the EKF state equations and represents the rotation of the intermediate frame about the gravity vector.

The measurement vector (6) consists of the three signals from the accelerometer, a_{IMU} , three signals from the gyroscope in the IMU frame and any drift associated with the gyroscope, w_{IMU} and b_{gyr} . An estimate of roll and pitch, r_{est} and p_{est} , respectively, using the acceleration signals and the direction of gravity are calculated and entered to the filter in the measurement vector, v_k ,

$$v_k = \begin{pmatrix} a_{IMU,k} \\ \omega_{IMU,k} + b_{gyr,k} \\ r_{est} \\ p_{est} \end{pmatrix} + w_k^{meas}, \quad (6)$$

where w_k^{meas} is the measurement noise at time k .

The process covariances were calculated using the ideal signals calculated with the kinematic model of the robot. Only covariances for a_{imb} , ω_{body} , and b_{gyr} were used. All other covariances were set to zero. The measurement covariances

were optimized so that the algorithm ‘‘listened’’ to the gyroscopes more closely than the accelerometer and estimated angle measurements.

The knee angle was found by subtracting the pitch angles of the ‘‘thigh’’ and ‘‘shank’’ segments of the robot. The segment orientation results from the EKF were compared to the orientations from the kinematic model. Only orientation data from the 2D Gait trials is reported in this study.

D. Foot Sensor and System Architecture

A prototype for a portable, attachable foot force/moment (F/M) sensor is currently under development. There is a separate sensor for the forefoot and heel and the design is such that measuring the shear portion in the ground reaction forces (GRF) will not affect the vertical GRF measurement. A ‘‘smart pylon’’ or F/M sensor for the prosthetic is also currently undergoing testing along with the electronic system that will wirelessly collect the F/M data and the IMU data from each of the lower leg segments once this system is ready for testing on human subjects.

III. RESULTS

A. IMU signals

By inspection, the accelerometers appeared noisier and less stable than the gyroscopes for both IMUs during the trial, an example of which can be seen in Figure 2. The IMU B accelerometer and gyroscope both appeared noisier than the IMU A equivalent. The gyroscope also appeared to match the calculated IMU data better than the accelerometer signals.

IMU B had higher root mean square error (RMSE) in both the gyroscope and accelerometer signals (Table 1). The accelerometer signal RMSE for IMU B ranged from 0.16 to 3.18 m/s² and the gyroscope RMSE ranged from 0.32 to 12.85 deg/s in all axes, with greater error typically occurring on the shank segment.

IMU A generally was less noisy and had lower RMSE than IMU B. The accelerometer RMSE for IMU B ranged from 0.10 to 1.88 m/s² with the gyroscope RMSE from 0.45 to 5.47 deg/s (Table 1). Similar to IMU B, typically greater error occurred on the shank segment.

B. Segment Orientation

The pitch RMSE for both the thigh and shank segments was 0.8 degrees and 0.5 degrees, respectively, when using IMU A. This translated to an error in the knee angle of slightly greater than 0.9 degrees. The EKF succeeded in limiting the amount of error caused by integrating the gyroscope signal and the roll values stayed close to 0.0 degrees.

IMU B resulted in RMSE values of 1.06 degrees and 2.04 degrees for the thigh and shank segments, respectively. This resulted in an RMSE of 2.2 degrees for the knee angle calculation.

IV. DISCUSSION

The objective of this project is to develop a system which uses inertial sensors and portable F/M sensors to easily and inexpensively perform biomechanical analysis during the prosthetic fitting and training period. This study focuses on the development of the motion analysis portion of this system and the testing of different IMUs. The authors believe the comparison between a “commercial” (IMU A) and “consumer” (IMU B) IMU with the intent of determining segment orientation is unique to this paper.

Commercial IMUs are typically higher quality, less noisy and more expensive. Consumer IMUs are used in modern smart phones and video game controllers and are typically noisy but smaller in size, less power hungry and can be 1/50th the cost of commercial IMUs. Looking at the RMSE in Table 1, it is clear which sensor provides better performance. Imperfect synchronization between the IMU signals and the reference data, and the resampling process are two sources of error and probably increases the RMSE. Also a difference between the actual and simulated placement of the IMU in the kinematic model would lead to inaccuracies in the accelerometer data calculation from the kinematic model.

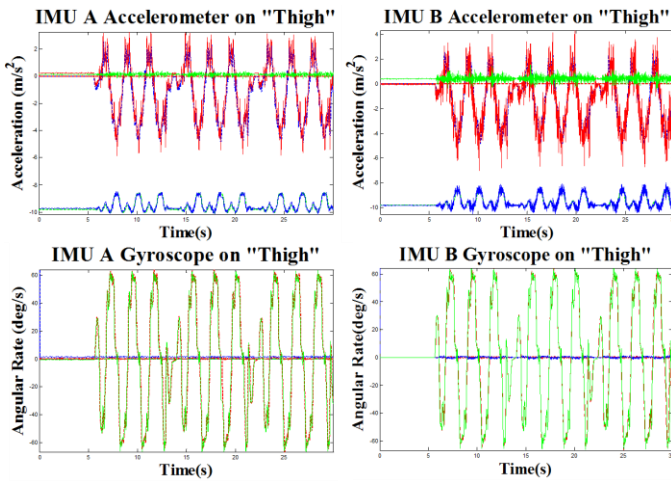

Figure 2: Accelerometer (top) and gyroscope (bottom) signals from IMU A (left) and IMU B (right) (solid lines) on the thigh segment of the robot during 2D Gait compared to calculated IMU signals (dashed lines) from the kinematic model.

TABLE 1: RMSE OF IMU DATA VS CALCULATED IMU DATA

		IMU	Accelerometer ^a			Gyroscope ^b		
			x	y	z	x	y	z
		2D Gait	Thigh	A	0.45	0.10	0.15	0.45
B	0.71			0.16	0.46	0.32	0.46	6.2
Shank	A		1.88	0.30	0.35	0.82	2.02	5.47
	B		3.18	0.56	0.51	0.70	0.97	12.85

a. Accelerometer values are the RMSE in m/s²

b. Gyroscope values are the RMSE in deg/s

The difference between the IMUs is also evident in the orientation results. The results of the commercial sensor are comparable to results from other authors who use gyroscopes

and accelerometers to calculate knee angle [4,5]. Although the EKF did succeed in limiting drift of the pitch and roll values in the IMU B trial, it was not able to overcome the errors in the gyroscope/accelerometer signals to accurately find the peaks and minimums of the pitch values. This resulted in a motion profile that looked dissimilar to the real motion. However, the attractiveness of the cost and size of these sensors will drive continued development of algorithms, including EKFs, that can manage the limitations of these sensors.

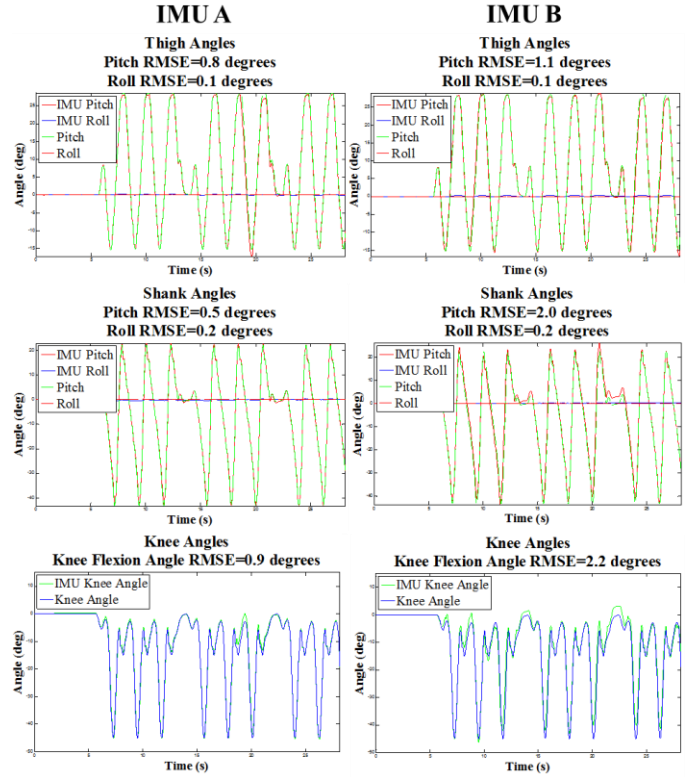

Figure 3: Orientation calculations using IMU A (left) and the IMU B (right) for the thigh (top), shank (middle) and knee angle (bottom) including the RMSE values compared to the actual orientation of the robot segments during 2D Gait simulation.

V. REFERENCES

- [1] Gawande A. Notes of a Surgeon Casualties of War — Military Care for the Wounded from Iraq and Afghanistan. *N Engl J Med.* 2004 351;24: 2473-2475.
- [2] Schmalz T, Blumentritt S, Jarasch R. Energy expenditure and biomechanical characteristics of lower limb amputee gait: the influence of prosthetic alignment and different prosthetic components. *Gait Posture.* 2002 Dec;16(3):255-63.
- [3] Cui, C.K., Chen, G., Kalman Filtering: with Real Time Applications, 3rd ed. Berlin: Springer, 1999.
- [4] Cooper, G., Sheret, I., McMillian, L., Siliverdis, K., Sha, N., Hodgins, D., Kenney, L., Howard, D. Inertial sensor-based knee flexion/extension angle estimation. *J. Biomech.* 2009: 42, 1678-1685.
- [5] Favre, J., et al.. Ambulatory measurement of 3D knee joint angle. *Journal of Biomechanics.* 2008: 41 (5), 1029–1035.

Appendix 2: Manuscript submitted to MHSRS 2012

Development of Mobile Gait Analysis System for Military Populations with Lower Limb Prosthetics

John Kyle P. Mueller, Boyd M. Evans, III, M. Nance Ericson, Ethan Farquhar, Randall Lind
Measurement Science and Systems Engineering Division
Oak Ridge National Laboratory
Oak Ridge, TN, USA
muellerjp@ornl.gov

Kevin Kelley, Martin Pusch
Otto Bock Healthcare Products
Dunderstadt, Germany

Jason M. Wilken
Military Performance Lab
Center for the Intrepid-Brooke Army Medical Center
Fort Sam Houston, TX

Abstract— Military service members with amputations are unique within the general amputee population as they are highly active and demand better prosthesis performance. We present kinematic data from the development of a mobile gait analysis system designed to assess lower limb amputees outside of a motion analysis laboratory. The overall goal of this project is to develop a mobile gait analysis system (MGAS) which can improve, streamline and quantify the prosthetic fitting process, ultimately improving the clinical effectiveness of prosthetic devices for wounded warriors. The MGAS system will determine limb orientation and joint angles using inertial measurement units and ground reaction forces using a portable shoe sensor and an instrumented pyramid adapter in a lower leg prosthetic. The kinematic capabilities of this MGAS system were validated in this current study using a robot which simulates the motions of a human leg. An algorithm including an extended Kalman filter was developed to collect the IMU data, determine limb orientation and consequently knee angle. The MGAS system calculation of robotic “knee” angle was accurate to 0.5 degrees and 0.8 degrees for two different walking motion patterns and 0.4 degrees RMSE for a slow stair climb activity. Further clinical comparison is planned with a patient population in a motion analysis facility where the accuracy of the orientation of each segment, including the foot, and the GRF forces from the foot sensor can be determined.

Keywords - Prosthetic, Motion Analysis, Inertial Measurement Unit, Ground Reaction Force Sensor, Wearable Sensors

I. INTRODUCTION

The advances made in battlefield treatment have resulted in a decrease in mortality among the wounded. Thousands of soldiers and veterans who survived their injuries now live with conditions like lower leg amputations which require long term,

lifelong care. The unique population of military amputees consists of young, athletic patients in top physical condition [1]. These patients stay physically active and in some cases wish to remain on active military duty. A patient with the need for a prosthesis is more likely to return to an active lifestyle for an extended period of time with better prosthesis function. Asymmetric gait is a symptom of a poorly fit or functioning prosthetic [2]. Asymmetric gait can result in overuse injuries and other chronic pathologies like arthritis in the patient’s healthy leg.

Asymmetric motion patterns and their effect on a patient’s joint kinetics and kinematics can be quantified using motion analysis tools. In general, this requires access to gait labs which require a large open space, are not readily available, and are expensive and in high demand. The iterative nature of a prosthetic fitting would require multiple gait analysis sessions which is time and cost prohibitive. Also many activities of daily living (ADL) may not be represented in a controlled lab environment. The objective of this present study is to develop a relatively inexpensive, portable, camera-less motion analysis system using portable force sensors and inertial measurement units (IMUs) that can give prosthetists instant biomechanical information and feedback regarding prosthetic performance and fit on individual soldiers.

II. MATERIALS AND METHODS

A. Robot Testing

Prior to evaluating with clinical subjects, a Mitsubishi Heavy Industry (Tokyo, Japan) PA-107C robot arm was used to calibrate the IMUs and test the sensors and data processing algorithm. The robot was controlled with a personal computer which moved it through a repeatable motion sequence while simultaneously recording the encoder data. A separate personal computer recorded the gyroscope and accelerometer data from the IMUs (Figure 1).

The robot was programmed to simulate the motion of a human leg using joint angle data from gait analyses of a healthy subject. The human leg has nine rotational degrees of

Funding provided by Department of Defense Congressionally Directed Medical Research Programs Funding Opportunity Number: W81XWH-09-PRORP-TDA

Oak Ridge National Laboratory (ORNL) is managed by UT Battelle, LLC for the U. S. Department of Energy under Contract No. DE-AC05-00OR22725.

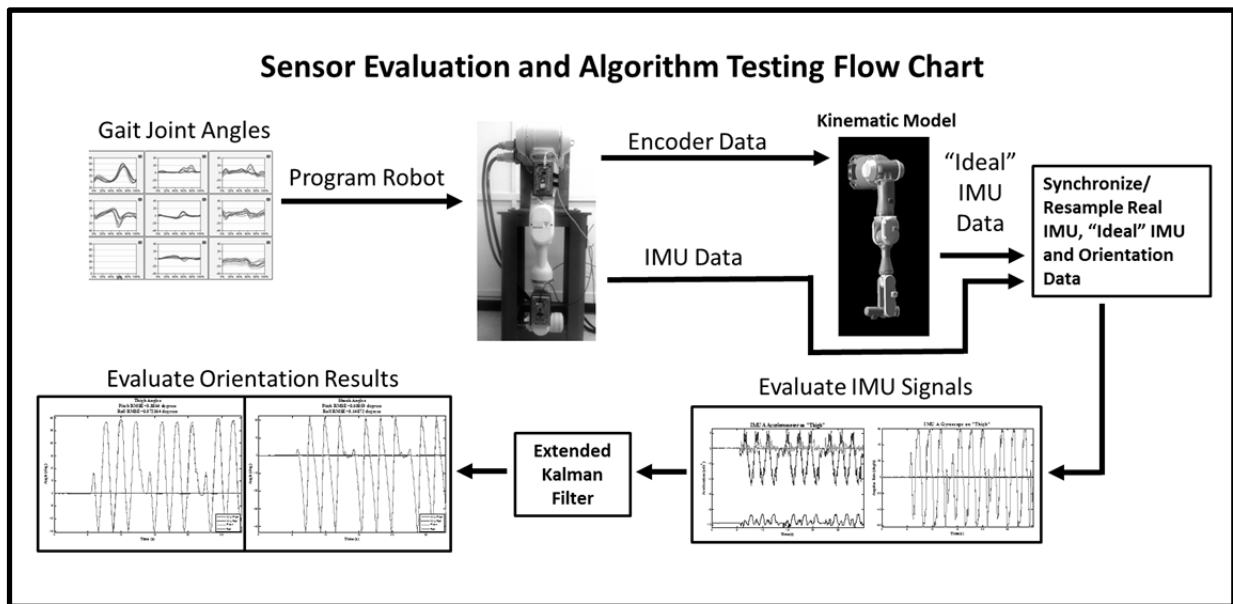

Figure 1: Flow chart describing the methods in this study including taking data from gait analysis to program the robot and using the encoder data to evaluate IMU and EKF results.

freedom (DOF) including the hip, knee and ankle while the robot can only represent six, thus, three DOF are excluded from the robot motion. The angles represented by the robot included hip flexion/extension, hip abduction/adduction, knee flexion/extension, abduction/adduction and internal/external rotation and foot flexion/extension. An IMU was attached to the “thigh” and “shank” segments of the robot. The goal was to determine the orientation of the segments and the angle between them, or the “knee” angle.

The motions evaluated for this study consist of two different walking patterns, Walking A (Figure 2) and Walking B, for the purposes of this study. Walking B is slightly faster than Walking A but simulates a smaller range of motion. The speed of the motions is limited by the capabilities of the robot arm. A slow stair climb motion was also simulated and called Stair Climb for the purposes of this study.

mean-squared-error (RMSE) between the MGAS orientation angles and the robot orientation angles were calculated.

B. Kinematic Model and IMU Signals

A mathematical model of the PA-10 was created using the Matlab (The Mathworks, Natick, MA) programming environment. The position and orientation of the IMUs relative to the robot segments, the robot joint angle data, and the robot segment lengths were the inputs for the model. The outputs were the position and orientation of the IMUs as well as calculated accelerometer and gyroscope “signals” used as the ground truth when determining the accuracy of the IMU signals. The calculated IMU data was used to synchronize the robot and IMU data, evaluate IMU performance and develop the algorithm used to calculate joint angles from IMU data (Fig. 1).

Leading up to this study, a range of IMU sensors were

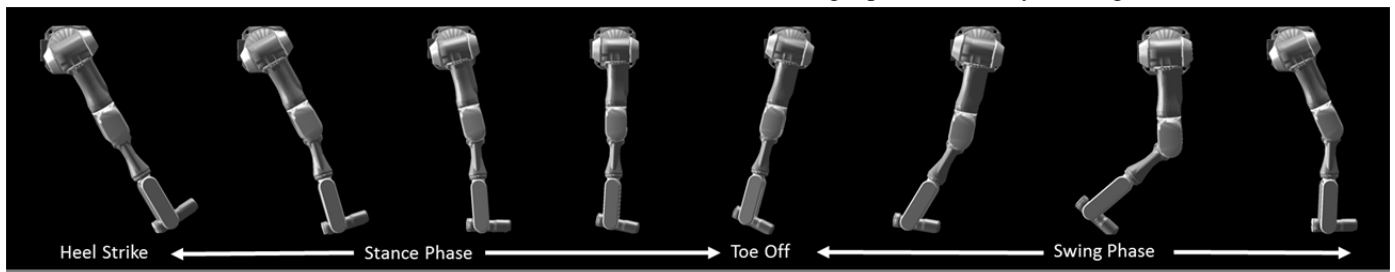

Figure 2: Sequence of images of robot kinematic model represented real robot motion.

IMUs were attached to the robot “thigh” and “shank” segments using custom holders designed to put the IMUs in the same place for each trial. For this study the IMU data was collected using a MSP430 (Texas Instruments, Inc., Dallas, TX) microcontroller and stored on a computer for post-processing using Matlab (The Mathworks, Inc. Natick, MA). Three trials were performed for all three activities. The root-

evaluated using the robotic procedure. One IMU chip that consists of an accelerometer and gyroscope was selected based on performance, cost, size, form factor, communication interface and ease of implementation. For future data collection and clinical testing, this chip was incorporated to an expansion board for a commercially available computer-on-module device that uses an ARM reduced instruction set processor that runs the Linux operating system, runs compiled

C++ code and incorporates wireless communication through Bluetooth and data storage with a micro SD card (Figure 3).

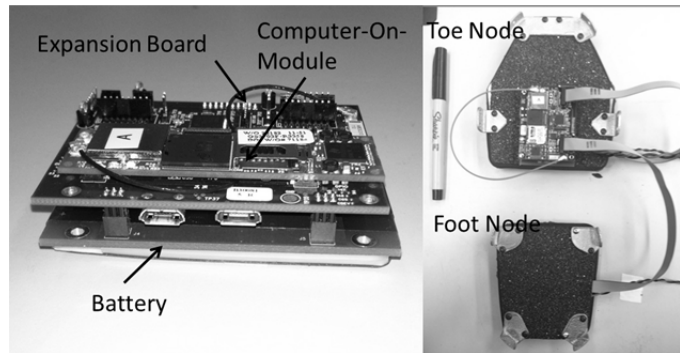

Figure 3: Computer-n-Module with expansion circuit board and battery for use on a limb segment (left) and the same board unit connected to the foot sensor.

The expansion board itself is designed for two applications. The first application is to control and manage data from a portable force/moment (F/M) foot sensor which is strapped to the bottom of the shoe (Figure 4). The foot sensor consists of a toe and heel nodes incorporating load cells that isolate loads in the cardinal directions to eliminate cross talk. These nodes are capable of very accurate force measurements in three dimensions that can be resolved to vertical (SI), anterior-posterior (AP) and medial-lateral (ML) ground reaction forces (GRF) and moments in each node. The toe and heel node each contain a circuit board consisting of signal conditioning and 16-bit (effective resolution of greater than 14.5 bits) analog to digital conversion (ADC) circuitry for 10 channels and the selected IMU sensor.

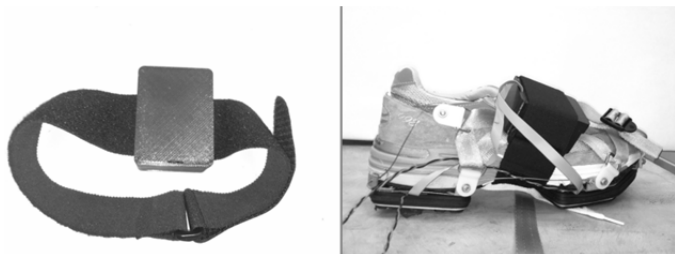

Figure 4: Enclosure and strap to attach inertial measurement unit to limb segment (left) and foot sensor attached to shoe (right).

A MSP430 microcontroller on the expansion board communicates to the ADC and IMU chips in the two sensor nodes and allows for on hardware timing to collect data at a consistent programmable 200 Hz sampling rate. The force and inertial data is read from the expansion board by the computer-on-module device and stored in the on-board SD card. A Lithium-Polymer battery provides power to the expansion board which, in turn, provides power to the computer-on-module device and the foot sensor circuitry. The Bluetooth and Wi-Fi capabilities of the computer-on-module allow for wireless control of the device and real-time data transmission to a host computer, tablet or phone.

The second application of the expansion board is as a limb segment (e.g. thigh, shank) IMU sensor (Figure 4). In this case

the MSP430 microcontroller controls the IMU and on-hardware clock. The battery only powers the expansion board and computer-on-module device which has the same function as the foot sensor application but only stores and transmits inertial data from the IMU on the expansion board. In both cases the expansion board manages the battery charge/discharge with power management circuits. A means to charge the battery, and command line access to the computer-on-module device, is provided through micro-USB on the expansion board.

C. Algorithm to Determine Joint Angles

The accelerometer signals, were used to determine the direction of gravity in the IMU reference frame, thus giving an estimate of the pitch and roll of the segment that is especially accurate when the robot is moving slowly or still. The angular velocity signals from the gyroscope were integrated to determine pitch, roll and yaw (heading) starting from an initial orientation. These calculations are subject to drift and noise which cause increasing error as the signal is integrated over time making these measurements on their own inaccurate.

An extended Kalman filter (EKF) [3] was developed to fuse the accelerometer and gyroscope data. The algorithm was inspired, but modified from a method presented in Cooper et al. [4]. The current EKF uses a 14-element state vector (1)

$$x = \begin{bmatrix} v_{int} \\ a_{int} \\ \omega_{IMU} \\ b_{gyr} \\ r \\ p \end{bmatrix} \quad (1)$$

where v_{int} and a_{int} are three-dimensional vectors of velocity and acceleration, respectively, transformed to an intermediate reference frame. The vectors ω_{IMU} and b_{gyr} are three-dimensional and represent the gyroscope signals and gyroscope bias in the IMU frame, respectively. The variables r and p are scalars representing the roll and pitch of the segment in the intermediate reference frame. Roll, pitch and yaw correspond to orientation in the sagittal plane, coronal plane and transverse plane, respectively, in the case of the lower leg or robotic lower leg. Initially, the intermediate reference frame is aligned with the Newtonian, or “lab”, reference frame but rotates about the vertical lab vector and is integrated outside of the EKF. The rotations from the laboratory frame to the IMU frames are represented using direction cosine matrices so pitch and roll rotations can be isolated while rotations about the gravity vector are ignored.

The measurement vector (2) consists of three accelerometer signals, a_{IMU} , and three gyroscope signals in the IMU frame and any drift associated with the gyroscope, w_{IMU} and b_{gyr} . An estimate of roll and pitch, r_{est} and p_{est} , respectively, using the acceleration signals and the direction of

gravity are calculated and entered to the filter in the measurement vector, v_k ,

$$v_k = \begin{pmatrix} a_{IMU,k} \\ \omega_{IMU,k} + b_{gyr,k} \\ r_{est} \\ p_{est} \end{pmatrix}, \quad (2)$$

where w_k^{meas} is the measurement noise at time k .

The process covariances represents what kind of data the sensor is expected to see and was calculated using the ideal signals calculated with the kinematic model of the robot. Only covariances for a_{imb} , ω_{body} , and b_{gyr} were used. All other covariances were set to zero. The measurement covariances were optimized so that the algorithm “listened” to the gyroscopes more closely than the accelerometer signals and estimated angle measurements.

The knee angle was calculated with the difference of the “thigh” and “shank” segments of the robot. The segment orientation results from the EKF were compared to the orientations from the kinematic model. The algorithm was run in post-processing for the current data.

D. Pylon Sensor and System Architecture

Along with the foot sensor mentioned earlier, a “smart pylon” or F/M sensor for a lower leg prostheses has been developed. This allows kinematic and kinetic evaluation of both the prosthetic and healthy limb.

The final design of the system will consist of seven IMUs, two from the foot sensor on the sound foot, one on the sound limb calf, two on each thighs, one on the trunk and one on the below the knee prosthesis. The data from these IMUs and the force data from the foot and adapter F/M sensors will be transmitted to a host device for data visualization. Currently the EKF algorithm is run on a host computer in real time or during post processing. The computer-on-module devices have enough speed and power that they will be used to run the sensor fusion algorithms for their particular segments, allowing for real time calculation of segment orientation and joint powers and torques.

III. RESULTS

A. Limb Orientation

The IMU and algorithm which will be incorporated into the MGAS system had a sagittal angle RMSE of 0.5 degrees or less for all segment and angle calculations, except for one.

The average results of the six trials of Walk A, were the thigh segment pitch RMSE was 0.2 degrees (stdev=0.1 degrees), shank segment pitch RMSE was 0.5 degrees (stdev=0.0 degrees) and the knee flexion calculation RMSE was 0.5 degrees (stdev=0.1 degrees) with a max error of 1.5 degrees (stdev=0.2 degrees) of knee flexion (Figure 6-Figure 7). The RMSE of the out of sagittal plane angles were not

calculated but by inspection are within one or two degrees throughout the trials.

The average results of the three trials of Walk B were the thigh segment pitch RMSE was 0.1 degrees (stdev=0.0 degrees), the shank segment pitch RMSE was 0.3 degrees (stdev=0.1 degrees) and the knee flexion RMSE was 0.8 degrees (stdev=0.2 degrees) (Figure 9-Figure 10). Similar to the Walk A data, by inspection the out of sagittal plane orientation data appeared to be within one or two degrees by visual inspection of the plots.

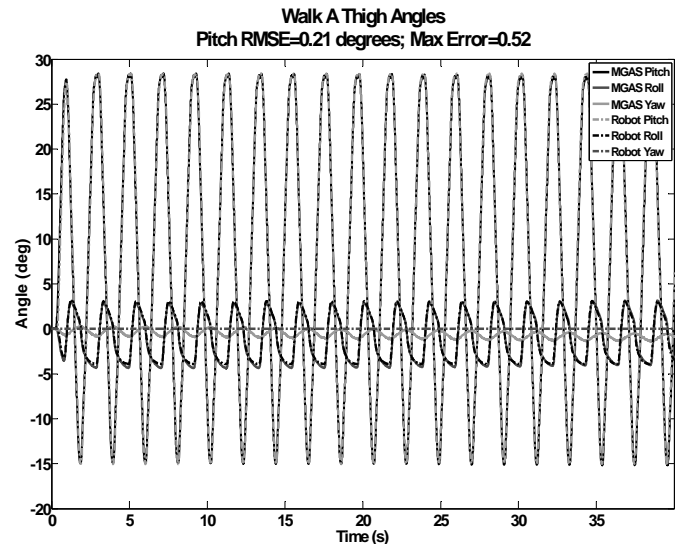

Figure 5: Sample trial of Walk A orientation angles from IMU data(MGAS values) and orientation angles calculated by the kinematic model (Robot values) for the “thigh” segment of the robot.

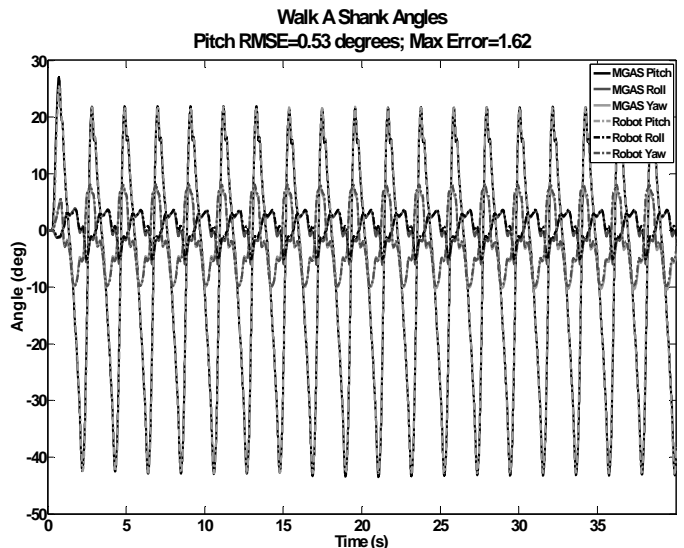

Figure 6: Sample trial of Walk A orientation angles from IMU data(MGAS values) and orientation angles calculated by the kinematic model (Robot values) for the “shank” segment of the robot. The pitch RMSE and maximum pitch angle error are also displayed for this trial.

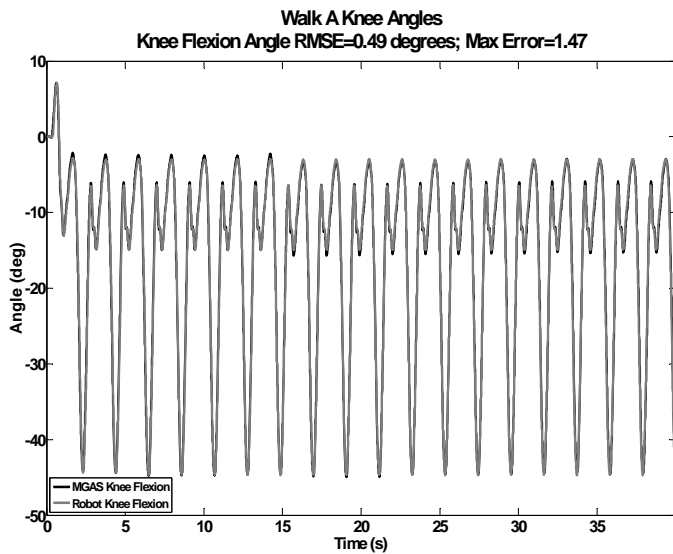

Figure 7: Sample trial of Walk A calculated knee flexion angles (MGAS values) and knee flexion angles calculated by the kinematic model (Robot values). The knee flexion RMSE and maximum knee flexion angle error are also displayed for this trial.

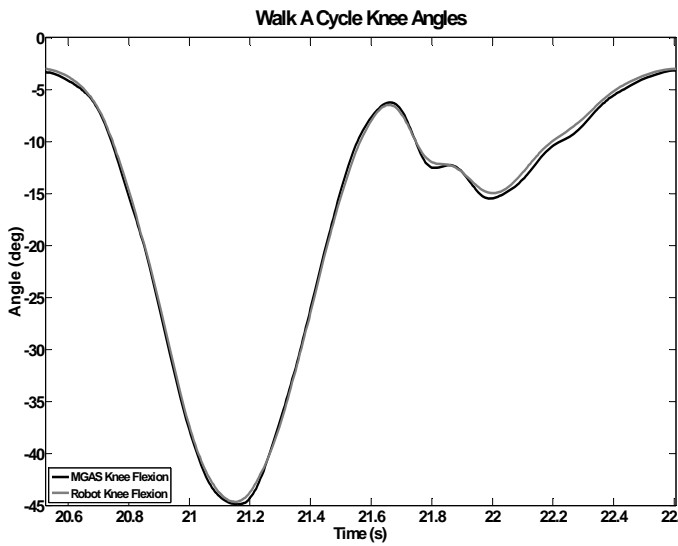

Figure 8: Sample trial of Walk A knee flexion angles from IMU data (MGAS values) and knee flexion angles from the kinematic model (Robot values) from one simulated gait cycle.

The average slow Stair Climb activity segment pitch RMSE for the thigh segment was 0.3 degrees (stdev=0.1 degrees), for the shank segment was 0.1 degrees (stdev=0.1 degrees) and for knee flexion 0.4 degrees (stdev=0.0 degrees) (Figure 11-Figure 12). Similar to the previous two activities the error of out of sagittal plane motion appeared to be within a few degrees by visual inspection of the data.

The average maximum knee flexion errors per trial were 1.5 degrees (stdev=0.2 degrees), 3.1 degrees (stdev=0.2

degrees) and 1.2 degrees (stdev=0.3 degrees) for Walk A, Walk B and Stair Climb activities, respectively (Figure 13).

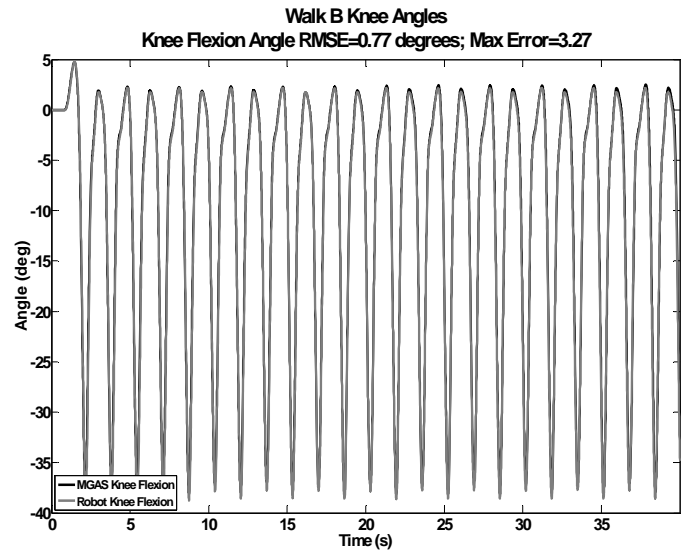

Figure 9: Sample trial of Walk B calculated knee flexion angles (MGAS values) and knee flexion angles calculated by the kinematic model (Robot values). The knee flexion RMSE and maximum knee flexion angle error are also displayed for this trial.

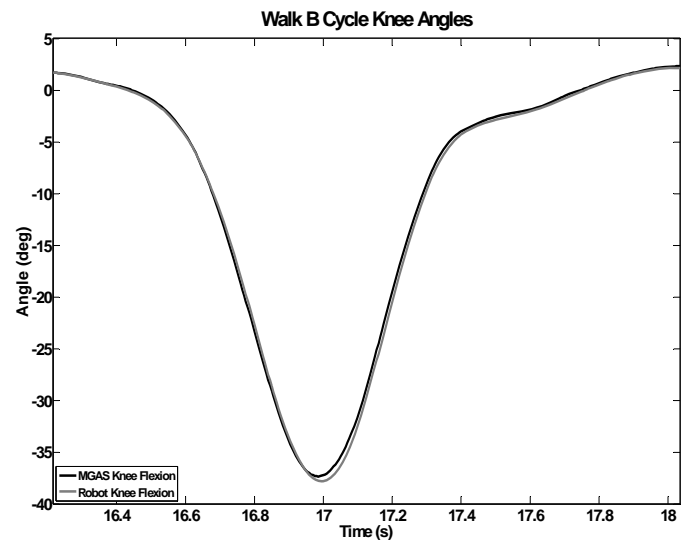

Figure 10: Sample trial of Walk B knee flexion angles from IMU data (MGAS values) and knee flexion angles from the kinematic model (Robot values) from one simulated gait cycle.

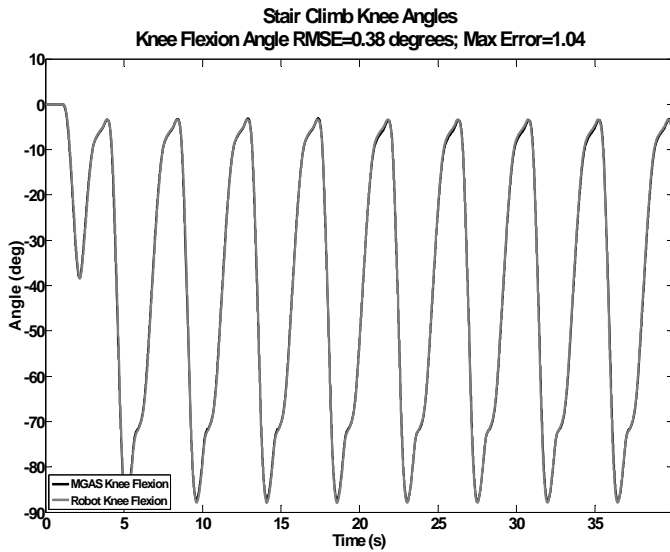

Figure 11: Sample trial of Stair Climb calculated knee flexion angles (MGAS values) and knee flexion angles calculated by the kinematic model (Robot values).

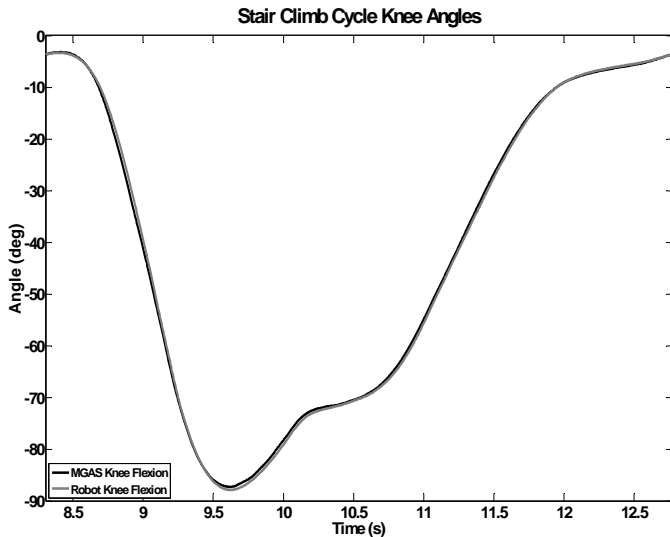

Figure 12: Sample trial of Stair Climb knee flexion angles from IMU data (MGAS values) and knee flexion angles from the kinematic model (Robot values) from one simulated gait cycle.

I. DISCUSSION

This project's objective is to develop a portable, easy to use system to provide more information to prosthetists and clinicians and quantify the prosthetic fitting process. By employing portable F/M sensors, small inexpensive IMUs and data fusion algorithms the proposed system will provide data normally only available through gait analysis in a motion capture lab. This portable system will provide more data about the military amputee patient population and allow easier access to tools that could help improve the performance of lower limb prosthetics.

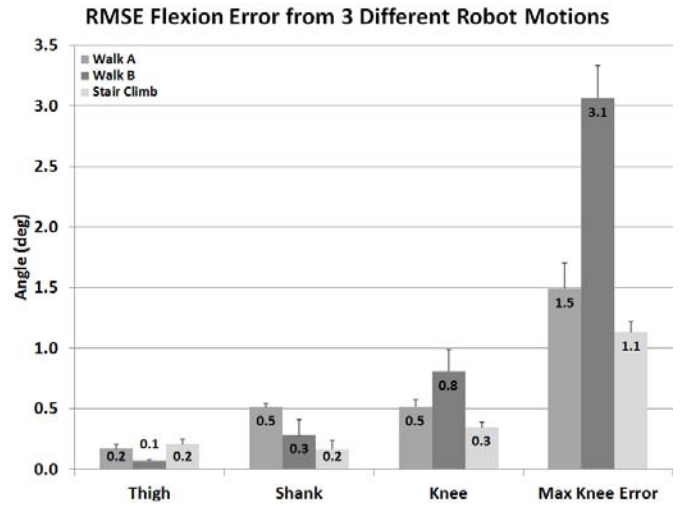

Figure 13: Summary of average RMSE error of MGAS orientation angles versus Robot Angles.

The focus of this current study is on the kinematics aspect of this project. The bench top testing reported here, using the robot leg to mimic a human leg, was essential in evaluation of different inertial sensors and in the development of the algorithm to extract sound orientation data from typical noisy and unstable accelerometer and gyroscope signals.

The results from these initial kinematic tests are promising. The RMSE values for sagittal plane orientations are within 1 degree RMSE, which was a loose goal set for the kinematic portion of the system. The out of sagittal plane motions are also accurate to within a few degrees. There is no additional reference for the yaw component of the limb orientation, therefore this calculation is dependent purely on the gyroscope signal and vulnerable to drift errors. This may be a factor in real world testing of the system when soft tissue artifact and inconsistent motion comes into play. However, we hypothesize that, with additional processing, a stable estimate of yaw orientation, or heading, can be made without the use of additional sensors such as magnetometers. By avoiding using magnetometers, the concern over ferrous perturbations is avoided and this system should work in any setting.

It is interesting that the error values for the thigh and shank segment during the Walk B activity were some of the lowest in the reported data. However, when these values were used to calculate knee angle, the average knee angle RMSE was the highest of the three activities. This is most likely due to inaccurate synchronization between the robot data and IMU data.

There are at least two caveats to the results reported here. The first is that there is a rigid connection between the IMUs and the robot segments. On human subjects, the goal is to track the orientation of the underlying bone, but skin and muscle artifact prevent this. However, camera-based motion analysis systems, considered the gold standard in gait analysis instrumentation, face the same issues.

The second caveat is the speed with which the activities presented were performed. From Figure 8, Figure 10 and Figure 12, a single gait cycle on the robot takes ~2 seconds, ~1.6 seconds and ~4.3 seconds for Walk A, Walk B and Stair Climb, respectively. A normal subject walking at a normal speed will complete a full gait cycle in ~1 second. The robot walking patterns are more like a very leisurely stroll. The motions used here were slower because of limitations of the robot arm. Validation testing in a clinical environment has been scheduled and will determine whether the accuracy of the system will hold up for faster and more complex motion patterns.

This study has shown that portable, inexpensive inertial sensors can be used to accurately track complicated repeated biomechanical motion. Incorporating this into the proposed MGAS will result in a tool that will give prosthetists, clinicians and researchers more information to improve the performance of lower leg prosthesis and the overall quality of life of our wounded warriors.

II. REFERENCES

- [1] Gawande A. Notes of a Surgeon Casualties of War — Military Care for the Wounded from Iraq and Afghanistan. *N Engl J Med.* 2004 351;24. 2473-2475.
- [2] Schmalz T, Blumentritt S, Jarasch R. Energy expenditure and biomechanical characteristics of lower limb amputee gait: the influence of prosthetic alignment and different prosthetic components. *Gait Posture.* 2002 Dec;16(3):255-63.
- [3] Cui, C.K., Chen, G., *Kalman Filtering: with Real Time Applications*, 3rd ed. Berlin: Springer, 1999.
- [4] Cooper, G., Sheret, I., McMillian, L., Siliverdis, K., Sha, N., Hodgins, D., Kenney, L., Howard, D. Inertial sensor-based knee flexion/extension angle estimation. *J. Biomech.* 2009; 42, 1678-1685.
- [5] Favre, J., et al., Ambulatory measurement of 3D knee joint angle. *Journal of Biomechanics.* 2008; 41 (5), 1029–1035.

Appendix 3: Approved IRB protocol

Brooke Army Medical Center
 Department of Clinical Investigation
 Office of the Institutional Review Board

**HUMAN SUBJECTS RESEARCH
 INITIAL PROTOCOL APPLICATION – Part A**

Date of application:	August 23, 2011
Study Title:	Development of a Mobile Gait Analysis System for Lower-Limb Amputee High-Level Activity Rehabilitation

1. Study Contacts

Principal Investigator:	Other Study Contact (if applicable)
Name and Degree: Jason M. Wilken, PT, PhD	Name and Degree: Christopher A. Rabago, PT, PhD
Title: Director, Military Performance Lab	Title: Research Physical Therapist
Mailing Address: BAMC, MCHE-DOR-I, 3851 Roger Brooke Dr, Fort Sam Houston, TX, 78234	Mailing Address: BAMC, MCHE-DOR-I, 3851 Roger Brooke Dr, Fort Sam Houston, TX, 78234
Phone Number: 210-916-1478	Phone Number: 210-916-9052
Email Address: Jason.Wilken@us.army.mil	Email Address: Christopher.Rabago@us.army.mil
Fax Number: 210-916-9016	Fax Number: 210-916-9016

2. Key Study Personnel (if more space is needed attach additional pages to the end of the application)

a. List all key study personnel **including the Principal Investigator (PI) and Other Study Contacts**, along with a brief statement of their study role(s) and responsibilities. NOTE: Key personnel are persons who have direct contact with subjects or their identifiable data or specimens.

Key Study Personnel	Study Roles and Responsibilities
Name: Jason M. Wilken Affiliated Institute: BAMC CFI	Study Role(s): Principal Investigator Responsibilities: Project management, data interpretation, manuscript preparation
Name: Christopher A. Rabago Affiliated Institute: BAMC CFI	Study Role(s): Associate Investigator Responsibilities: Research Physical Therapist, patient screening, recruitment, consenting, data collection and analysis, data interpretation, manuscript preparation
Name: Abbie Ferris Affiliated Institute: BAMC CFI	Study Role(s): Research Assistant Responsibilities: Data collection and analysis, ability to consent subjects
Name: Deanna H. Gates Affiliated Institute: BAMC CFI	Study Role(s): Research Assistant Responsibilities: Data collection and analysis, ability to consent subjects
Name: Jennifer Aldridge Affiliated Institute: BAMC CFI	Study Role(s): Research Assistant Responsibilities: Data collection and analysis, ability to consent subjects
Name: Kelly Rodriguez Affiliated Institute: BAMC CFI	Study Role(s): Research Assistant Responsibilities: Data collection and analysis, ability to consent subjects

b. List all other study personnel involved in the research, for example statistician, consultants, collaborators.

Key Study Personnel	Study Roles and Responsibilities
Name: Boyd M. Evans III Affiliated Institute: Oak Ridge National Laboratory	Study Role(s): Consultant Responsibilities: Device design and management, present during onsite data collection, receipt of only de-identified data, data analysis and interpretation
Name: Nance Ericson Affiliated Institute: Oak Ridge National Laboratory	Study Role(s): Consultant Responsibilities: Device design and management, present during onsite data collection, receipt of only de-identified data, data analysis and interpretation
Name: John Mueller Affiliated Institute: Oak Ridge National Laboratory	Study Role(s): Consultant Responsibilities: Device design and management, present during onsite data collection, receipt of only de-identified data, data analysis and interpretation
Name: Randy Lind Affiliated Institute: Oak Ridge National Laboratory	Study Role(s): Consultant Responsibilities: Device design and management, present during onsite data collection, receipt of only de-identified data, data analysis and interpretation
Name: Ethan Farquhar Affiliated Institute: Oak Ridge National Laboratory	Study Role(s): Consultant Responsibilities: Device design and management, present during onsite data collection, receipt of only de-identified data, data analysis and interpretation
Name: Ziyuan Liu Affiliated Institute: Oak Ridge National Laboratory	Study Role(s): Consultant Responsibilities: Device design and management, present during onsite data collection, receipt of only de-identified data, data analysis and interpretation
Name: Martin Pusch Affiliated Institute: Otto Bock Healthcare	Study Role(s): Consultant Responsibilities: Device design and management, present during onsite data collection, receipt of only de-identified data, data analysis and interpretation
Name: Simone Oehler Affiliated Institute: Otto Bock Healthcare	Study Role(s): Consultant Responsibilities: Device design and management, present during onsite data collection, receipt of only de-identified data, data analysis and interpretation
Name: Kevin Kelly Affiliated Institute: Otto Bock Healthcare	Study Role(s): Consultant Responsibilities: Device design and management, present during onsite data collection, receipt of only de-identified data, data analysis and interpretation

c. If study is **greater than minimal risk**, a medical monitor must be identified:

Name:

Affiliated Institute:

Not applicable:

3. Study Facilities (if more space is needed, attach additional pages to the end of the application)

List all locations where subjects will be recruited and where study procedures will be performed	
Site	Activities to be performed at site
Center for the Intrepid	All recruitment, data collection, data processing, data analysis and storage

4. Multi-Site Research

No If no, skip to #5 below

- Yes: *If yes, will this site function as the coordinating center?*
 No Yes: *If yes, complete the table below*

(if more space is needed, attach additional pages to the end of the application)

Name of Performance Site*	Investigator at Performance Site	Performance Site IRB

* Each institution or performance site engaged in research will require IRB approval.

5. Scientific Review *(Documentation of scientific review is required before final HQ USAMRMC IRB approval will be granted)*

- Completed Review Pending

6. Additional Approvals – *(Copies of approval memoranda are required before final IRB approval will be granted)*

a. Check all that are required by your institution:

- | | | |
|--|---|---|
| <input checked="" type="checkbox"/> Impact Statement(s) | <input type="checkbox"/> Completed | <input type="checkbox"/> Review Pending |
| <input type="checkbox"/> Pharmacy | <input type="checkbox"/> Completed | <input type="checkbox"/> Review Pending |
| <input type="checkbox"/> Nursing | <input type="checkbox"/> Completed | <input type="checkbox"/> Review Pending |
| <input type="checkbox"/> Radiology | <input type="checkbox"/> Completed | <input type="checkbox"/> Review Pending |
| <input checked="" type="checkbox"/> Other: DOR | <input checked="" type="checkbox"/> Completed | <input type="checkbox"/> Review Pending |
| <input type="checkbox"/> Institutional BioSafety Committee | <input type="checkbox"/> Completed | <input type="checkbox"/> Review Pending |
| <input type="checkbox"/> Radiation Safety Committee | <input type="checkbox"/> Completed | <input type="checkbox"/> Review Pending |
| <input type="checkbox"/> Other: | <input type="checkbox"/> Completed | <input type="checkbox"/> Review Pending |
| <input type="checkbox"/> Not Applicable | <input type="checkbox"/> Completed | <input type="checkbox"/> Review Pending |

b. If the research will be conducted outside of the Principal Investigator's institution, approval by the performance site will be required.

- Not Applicable Letter Obtained Letter Pending

c. If the research will be conducted with a military unit, a letter of support from the Unit Commander will be required before final IRB approval will be granted.

- Not Applicable Letter Obtained Letter Pending

7. Funding Information

- Not Applicable
 Internal Funding:
 External Funding *(List all sources that apply, including all Industry Sponsors; list award numbers. If more space is needed attach additional pages to the end of the application)*

Agency / Sponsor	Award Number
Peer Reviewed Orthopedic Research Program, Congressional Directed Medical Research Program	Award #: W81XWH-1-2-0087

8. Drugs, Dietary Supplements, Biologics, and Devices

a. Will ANY drugs, dietary supplements, biologics, or devices be utilized in this research protocol?

- No *If no, skip to #10 below*

Yes *If yes, continue to #8B Note that additional information is required in the study protocol whether or not the drug, device, or biologic is FDA-regulated or not. and/or investigator brochure for FDA-regulated products, as per the ORP IRB Office "Guidelines for Investigators"*

- b. List all **non-investigational** drugs, dietary supplements, biologics, and/or devices to be used in this study. If not applicable, skip to #8C.

(if more space is needed attach additional pages to the end of the application)

Name

- c. List all **investigational** drugs, dietary supplements, and/or biologics to be used in this study. *If not applicable, skip to #8D.*

(if more space is needed attach additional pages to the end of the application)

Name(s)	List IND #* (include pending or exemption)	Who holds the IND?
		<input type="checkbox"/> Sponsor <input type="checkbox"/> Investigator*** <input type="checkbox"/> Other:
		<input type="checkbox"/> Sponsor <input type="checkbox"/> Investigator*** <input type="checkbox"/> Other:
		<input type="checkbox"/> Sponsor <input type="checkbox"/> Investigator*** <input type="checkbox"/> Other:

* Include documentation from the sponsor or FDA identifying the IND number for this study.

*** Investigators who hold an IND are responsible for following FDA regulatory requirements for sponsors (www.fda.gov/downloads/RegulatoryInformation/.../UCM126572.pdf)

d. List all **investigational** devices to be used in this study. If not applicable, skip to #10.

(if more space is needed attach additional pages to the end of the application)

Name(s)	List IDE#* (include pending or exemption)	Who holds the IDE?
Mobile Gait Analysis System	Pending IRB review	<input type="checkbox"/> Sponsor <input type="checkbox"/> Investigator*** <input checked="" type="checkbox"/> Other: Ottobock HealthCare/Oak Ridge National Lab
		<input type="checkbox"/> Sponsor <input type="checkbox"/> Investigator*** <input type="checkbox"/> Other:
		<input type="checkbox"/> Sponsor <input type="checkbox"/> Investigator*** <input type="checkbox"/> Other:
Sponsor/PI's <u>Device</u> Risk Determination: <input checked="" type="checkbox"/> Non-Significant Risk Determination Requested ** <input type="checkbox"/> Significant Risk Device		

* Include documentation from the sponsor or FDA identifying the IDE number for this study.

** Include documentation supporting the request for a determination of Non-Significant Risk (<http://www.fda.gov/MedicalDevices/DeviceRegulationandGuidance/GuidanceDocuments/ucm126622.htm>)

*** Investigators who hold an IDE are responsible for following FDA regulatory requirements for sponsors (www.fda.gov/downloads/RegulatoryInformation/.../UCM126572.pdf)

9. Clinical Trial Registration

Public Law 110-85 requires registration of clinical trials (http://frwebgate.access.gpo.gov/cgi-bin/getdoc.cgi?dbname=110_cong_public_laws&docid=f:publ085.110.pdf). The International Committee of Medical Journal Editors (ICMJE) also requires registration of clinical trials in order for results to be published in member biomedical journals. Additional information, including guidance on the registration process is at ClinicalTrials.gov

ClinicalTrials.gov "NCT" number:
 Registration pending
 Registration is not required.

10. Target Population(s) - check all that apply.

Adults (18 – 90) Age Range:
 Children
 Pregnant Women
 Fetuses
 Military Personnel
 Individuals Not Able to Provide Informed Consent
 Adults with Diminished Capacity
 Employees of the Performance Site
 Individuals/Legal Authorized Representative Not Able to Provide Advanced Informed Consent
 Prisoners
 Other:

11. Waivers/Alterations of the Informed Consent/Assent Process - check all that apply.

a. Not applicable > skip to #12 below

b. Waiver of informed consent - For the IRB to grant a waiver of informed consent, all of the following criteria must be addressed in the informed consent section of the protocol:

- 1) The research involves no more than minimal risk to the subject.
- 2) The waiver will not adversely affect the rights and welfare of the subjects.
- 3) The research could not be practicably carried out without the waiver of informed consent.
- 4) Subjects will be provided with additional pertinent information after participation, whenever appropriate.

c. Alteration/modification of the informed consent process – An alteration must be requested when the process of informed consent involves a delay in obtaining informed consent. For the IRB to grant an alteration to the informed consent process, the protocol must describe how the informed consent/assent process will be altered. The following criteria must also be addressed in the informed consent section of the protocol:

- 1) The research involves no more than minimal risk to the subject.
- 2) The waiver will not adversely affect the rights and welfare of the subjects.
- 3) The research could not be practicably carried out without the waiver of informed consent.
- 4) Subjects will be provided with additional pertinent information after participation, whenever appropriate.

d. Waiver of signed informed consent – Although the subject will not sign a consent document, all elements of informed consent must be provided to the subject, and a consent must be submitted for IRB review.

Check the applicable box:

The only record linking the subject and the research would be the consent document and the principal risk would be potential harm resulting from a breach of confidentiality, and the research is not FDA-regulated. **NOTE:** The informed consent section of the protocol must describe the plan for ensuring that if the subject wants his/her name linked with the research, the subject's wishes will be carried out.

The research presents no more than minimal risk of harm to subjects and involves no procedures for which written consent is normally required outside of the research context.

e. Waiver of Assent for Child

1) A waiver of assent is being requested for (check one):

All children involved in research.
 Some children involved in the research. **NOTE:** The children for whom the waiver of assent is being requested must be distinguished in the protocol.

2) Assent will not be obtained from the children because (check all that apply):

Children will be unable to provide assent because of their age. Generally, children 7 years of age and older are considered capable of giving assent.
 The capability of all or some of the children is so limited that they cannot reasonably be consulted.
 The intervention or procedures involved in the research holds out a prospect of direct benefit that is important to the health or well-being of the children and is available only in the context of the research.
 The research focuses on public benefit or services & is subject to approval or direct supervision of state or local government officials AND to get assent/consent would make the research impracticable.

f. Waiver of Parental/Legal Guardian Permission - Check the applicable boxes:

The research is designed for conditions or for a subject population for which parental/guardian permission is not a reasonable requirement to protect subjects (e.g., neglect, abuse). **NOTE:** The protocol must describe the mechanism for protecting the children who will participate as subjects in the research that will be substituted for parental/guardian permission.

Permission from parents/guardians of children will not be obtained because the answers to **all** of the following questions is "yes" (**NOTE:** these criteria must be addressed in the informed consent section of the protocol):

The research involves no more than minimal risk to subjects.

The rights/welfare of the subjects will not be adversely affected.

The research could not practicably be carried out without the alteration or waiver.

Subjects will be provided with additional pertinent information after participation if appropriate.

12. HIPAA Authorization. Are you employed by a covered entity or are you involving a covered entity in your research, and utilizing, accessing, collecting, or generating private health information as part of the study?

No. The research is not subject to the HIPAA requirement.

Yes. HIPAA Authorization will be obtained from the subjects

Yes. A Waiver of HIPAA Authorization will be requested. For the IRB to grant a Waiver of HIPAA Authorization, *all of the following criteria must be met:*

a) The use or disclosure of Protected Health Information involves no more than minimal risk to the privacy of subjects

b) The research could not practicably be conducted without the waiver of authorization.

c) The research could not practicably be conducted without use of the health information.

13. Documents to be submitted for review:

- Scientific Review
- Current *Curriculum vitae* for each investigator
- Documentation of CITI training within the last 3 years for each key study team member
- Conflict of Interest form for each investigator
- All applicable Impact Statement(s)
- Protocol and signature page, if applicable
- Informed Consent Document, unless a waiver is requested in the protocol
- Data collection forms/CRFs

Other documents to be submitted for review, as applicable to this study:

- Assent Document(s)
- Medical Monitor *Curriculum vitae* required for Greater Than Minimal Risk protocols
- Documentation of approval by the performance site
- Unit Commander Letter of Support, if applicable
- Recruitment material (for example, telephone script, flyer, web posting, email)
- Study instruments
- Data Use Agreement(s)
- Product Information
- Investigational Brochure
- Device Manual

Brooke Army Medical Center
Department of Clinical Investigation
Office of the Institutional Review Board

**HUMAN SUBJECTS RESEARCH
INITIAL PROTOCOL APPLICATION – Part B**

1. PROTOCOL TITLE.

Development of a Mobile Gait Analysis System for Lower-Limb Amputee High-Level Activity Rehabilitation

2. ABSTRACT.

A significant number of service members returning from the current conflicts are recovering from major traumatic injuries including limb amputation. The vast majority of these patients are under 25 years of age [1], and expect to return to a highly active, pre-injury lifestyle. We propose to develop a Mobile Gait Analysis System to help train service members to use their prostheses most efficiently. This would assist in the return to activities of daily living, sport, recreation, and occupation which may include the continuation on active duty. The Mobile Gait Analysis System (MGAS) will determine forces and motions of both the affected and intact limbs outside of a traditional motion-capture gait laboratory. The MGAS will also revolutionize the process of prosthesis fitting by allowing alignment, and load-balancing to be based on both static and dynamic loads. The MGAS will be developed as part of collaboration between Brooke Army Medical Center's Center for the Intrepid, the Oak Ridge National Laboratory, and Otto Bock Healthcare. This project is funded through a grant awarded to Dr. Boyd M. Evans III by the Peer Reviewed Orthopedic Research Program which is part of the Congressional Directed Medical Research Program. This proposal builds on work completed as part of the BAMC IRB approved protocol (C.2011.005n) entitled "Mobile Gait Analysis for Lower-Limb Amputee High-Level Activity Rehabilitation." The previous protocol provided initial biomechanical parameters to Oak Ridge National Lab from gait studies conducted in the Military Performance Laboratory at the Center for the Intrepid (CFI). Oak Ridge National Lab and Otto Bock Healthcare continue to develop the MGAS components. We propose to validate the function of the system components using conventional quantitative gait analysis while individuals perform functional tasks. We propose to enroll 14 uninjured and 21 injured service members over the next 3 years who will perform tasks such as walking on level ground, up/down stairs, and up/down inclines using the MGAS. De-identified biomechanical data will be shared with Oak Ridge National Lab and Otto Bock Healthcare for the purposes of optimizing and validating MGAS function. A subgroup (N=14) of the injured service members and their clinicians will be asked to provide feedback on the usability and utility of the MGAS. At the conclusion of this study, we expect this state-of-the-art Mobile Gait Analysis System will allow the optimization of prosthetic fitting and functional training of service members, thus maximizing their attainment of rehabilitation goals.

3. OBJECTIVES/SPECIFIC AIMS/RESEARCH QUESTIONS.

The purpose of this study is to develop a Mobile Gait Analysis System which can be used to assess and optimize the biomechanics of young service members with amputation during performance of a wide range of functional tasks. Specifically, our Aims address validating and optimizing the function of the MGAS as well as determining its usability and utility as a clinical tool.

Aim 1: To validate the Mobile Gait Analysis System initial hardware components.

1a: To evaluate orientation hardware component function.

We will compare biomechanical data from the orientation hardware components and a conventional motion-capture system in MPL's gait lab as uninjured healthy subjects perform level-ground walking, incline walking, and stair climbing. The accuracy and drift of the orientation hardware components will also be determined.

Aim 1b: To evaluate shoe-mounted ground reaction force measuring system function.

We will compare biomechanical data from the shoe-mounted ground reaction force measuring system and a conventional force-plate system in MPL's gait lab as uninjured healthy subjects perform level-ground walking, incline walking, and stair climbing. The accuracy and drift of the shoe-mounted ground reaction force measuring system components will be determined.

Aim 2: To determine the clinical utility of a prototype Mobile Gait Analysis System in a patient population.

Aim 2a: To validate the biomechanical data from the Mobile Gait Analysis System in a patient population.

Biomechanical data from the prototype Mobile Gait Analysis System will be collected while individuals with unilateral trans-tibial amputations perform level-ground walking, incline walking, and stair climbing. These data will be compared with data acquired from motion capture and force plate systems in the MPL's gait lab. Results will be analyzed to ensure that motions, forces, and moments are adequately characterized.

Aim 2b: To determine the usability and utility of Mobile Gait Analysis System from the perspective of patients.

Upon use of the prototype Mobile Gait Analysis System, patients from Aim 2a will be asked to evaluate its utility, comfort, and ease of use. Comments will be collected, documented, and evaluated. Constructive feedback is expected which will result in improved system usability and utility.

Aim 2c: To determine the usability and utility of Mobile Gait Analysis System from the perspective of clinicians.

Upon use of the prototype Mobile Gait Analysis System with their patients, treating clinicians will be asked to evaluate its comfort, ease of use, and clinical utility. Comments will be collected, documented, and evaluated. Constructive feedback is expected which will result in improved system usability and utility.

Aim 3: To determine the clinical utility of the Mobile Gait Analysis System's alignment function in a patient population.

Biomechanical data from the Mobile Gait Analysis System will be collected while individuals with unilateral trans-tibial amputations perform level-ground walking, incline walking, and stair climbing. Alignment of the patient's prosthesis will be adjusted based on data from the Mobile Gait Analysis System. The physical tasks will be repeated with each change to the prosthesis alignment in order to optimize patient performance. Biomechanical data acquired from motion capture and force plate systems in the gait lab will be used to validate alignment instrumentation and associated procedures.

Aim 4: To determine the clinical utility of the FINAL Mobile Gait Analysis System in a patient population.

Aim 4a: To validate the biomechanical data from the Mobile Gait Analysis System in a patient population.

Biomechanical data from the Mobile Gait Analysis System will be collected from the trunk, pelvis, and both limbs of individuals with unilateral trans-tibial amputations as they perform level-ground walking, incline walking, and stair climbing. These data will be compared with data simultaneous acquired from motion capture and force plate systems in the MPL's gait lab. Results will be analyzed to ensure that motions, forces, and moments are accurately determined.

Aim 4b: To determine the usability and utility of Mobile Gait Analysis System from the perspective of patients.

Upon use of the Mobile Gait Analysis System, patients from Aim 4a will be asked to evaluate its utility, comfort, and ease of use. Comments will be collected, documented, and evaluated. Constructive feedback is expected which will result in improved system usability and utility.

Aim 4c: To determine the usability and utility of Mobile Gait Analysis System from the perspective of clinicians.

Upon use of the Mobile Gait Analysis System with their patients, treating clinicians will be asked to evaluate its comfort, ease of use, and clinical utility. Comments will be collected, documented, and evaluated to aid in clinician training and procedural optimization.

4. MILITARY RELEVANCE.

The rehabilitation needs of our wounded service members are vastly different from those of the general population. Our highly-trained service members often have physiology that resembles that of a professional athlete with physical performance goals set to match. However, due to current conflicts, a significant number of service members are injured at the prime of their physical conditioning. While it is true that thousands of civilians undergo lower extremity amputations each year, the majority of these are the result of severe diseases such as diabetes, infection, and ischemia. Patients within these diseased populations are usually inactive and in poor physical condition prior to their amputation. They rarely possess the ability to walk again making them poor candidates for this particular study. The goal of this project is to develop a Mobile Gait Analysis System (MGAS) which can be used to assess the biomechanics of patients with high levels of physical fitness as would be found in our military population. It is expected that this clinical tool will be used to evaluate patients performing strenuous activities which may enable them to return to a pre-injury level of activity or possibly back to active duty. The success of the MGAS will allow the optimization of prosthetic fitting and functional training of service members, thus maximizing their rehabilitation goals.

5. BACKGROUND AND SIGNIFICANCE.

The vast majority of our wounded service members are under 25 years of age [1], with major traumatic injuries including limb amputation who expect to return to a highly active, pre-injury lifestyle (Figure 1). Motion-capture biomechanical analysis has proven to be a valuable tool for evaluating the functional mobility of individuals with pathologies to include lower-limb amputation, joint replacement, and musculoskeletal injury and disease [2-10]. Motion-capture biomechanical analysis is the science of recording and analyzing the motion of subjects in order to evaluate and document the pathologies that affect gait or motion. Modern biomechanical analysis laboratories typically use a system of video cameras mounted around the periphery of the laboratory; the video cameras emit infrared light which is reflected by tracking markers placed at key anatomical positions on the subject. Software analysis systems exist to convert the data from these cameras into three dimensional motions. Ground reaction forces can be determined through the use of force measuring plates placed in the floor. Using the principles of dynamics, the joint forces and torques can be computed from the ground reaction forces and the limb segment motions using a technique referred to as inverse dynamics.



Figure 1: Young individual with the desire to resume an active lifestyle thus placing higher demands on prosthetic components.

Motion-capture biomechanical analysis may also be used in the evaluation of prosthetic devices used by individuals with lower extremity amputation [11-14]. Kenton Kauffman and researchers at the Mayo Clinic have explored the changes in energy expenditure, activity, gait, and balance of patients wearing microprocessor-controlled prosthetic knees [15-16]. Investigators, Gard and Konz, determined that shock-absorbing pylons are of “significant benefit” for persons with transtibial amputation who are able to routinely walk at speeds greater than 1.3 m/s using motion-capture biomechanical gait analysis [17]. Schmalz also published an extensive study comparing the stair ambulation biomechanics in transtibial and transfemoral amputees and reported that overload of the contralateral limb is more prominent in transfemoral amputees for stair descent among other results [18]. These results represent a portion of the research using motion-capture gait analysis and demonstrate its utility in understanding the kinetics and kinematics of patients recovering from amputation.

A limitation of these motion-capture gait analysis studies is the requirement for them to be performed inside dedicated gait laboratories. These laboratories are not easily accessible or practical for many clinicians and rarely include environmental elements (i.e. slopes, stairs, unstable terrain, etc) similar to those normally encountered throughout one’s day. A system that would allow the acquisition of motion and force data both indoors and outdoors would be particularly beneficial for individuals performing high-level activities normally constrained by indoor facilities. The development of a Mobile Gait Analysis System (MGAS), which overcomes current motion-capture gait analysis limitations, is possible due to recent advances in micro-sensors and wireless electronics. The proposed MGAS will determine forces and motions of amputated and intact limbs outside of a traditional motion-capture gait laboratory. The MGAS will also revolutionize the process of prosthesis fitting by allowing alignment, load-balancing, and patient training based on static and dynamic loading characteristics. This is possible because the system will employ modular wireless sensors capable of measuring prosthesis moments and forces (kinetics) as well as prosthesis orientation (kinematics). From this information, ground reaction forces, socket-limb forces, and prosthesis position can be determined during a variety of activities in the field without environmental constraints. Data from these measurements will promote greater understanding of the individual prosthesis function enabling improvements in prosthetic design and function during a variety of activities.

Several research groups have performed some very interesting work attaching various sensors to prosthetic devices. Although some devices are commercially available for the monitoring of amputee activity, these devices primarily monitor and record the number of steps taken over a given period. They do not obtain the quality of data normally acquired in a motion-capture gait laboratory [19-20]. Research in the measurement of prosthetic loads has been published by Joan Sanders and colleagues at the University of Washington. This group investigated a novel strain-gauge based load cell and also used strain gages placed on pylons to measure prosthetic forces. They implemented strain gage-based devices to measure socket pressure and examine prosthetic fit [25, 21]. In 2007, Hugh Herr and his group at the Massachusetts Institute of Technology (MIT) presented data on a powered ankle-foot prosthesis. This robotic, lower-limb prosthetic device incorporates a DC motor to produce a biomimetic motion and incorporates a six-directional force-torque sensor from ATI automation to measure forces and moments. This device was used to estimate ground reaction forces and zero moment point [22-23]. Recently, Morris, et al. presented research on a wireless, shoe-mounted sensor system capable of detecting heel-strike and toe-off, as well as estimating foot orientation and position [24]. Several systems have used force sensitive resistors in the shoe to characterize gait including the tethered system by Wertsch for distinguishing between shuffling and normal gait [25-26]. Vildjiounaite and others in Finland developed a distributed system based on magnetic sensors and accelerometers for tracking location and recognition of walking patterns [27]. Pappas with fellow Swiss researchers investigated the use of force sensitive resistors and a gyroscope for detection of the primary gait components of heel-strike, stance, swing, and toe-off [28]. These systems provide insight into the use of mobile instrumentation for gait analysis. Our system seeks to build upon this work by producing a system capable of fully-characterizing the motion of the lower body in a small, affordable, modular system.

The MGAS will be developed as part of collaboration between Brooke Army Medical Center's Center for the Intrepid, the Oak Ridge National Laboratory Monolithic Systems Group, and Otto Bock Healthcare. The Monolithic Systems Group has been dedicated to the development of miniaturized application specific integrated circuits and the miniaturization of sensor technology [29-30] using the phenomenal reductions in size offered by the micro- and nano-technology revolution. The Monolithic Systems Group has devoted significant resources to the challenges associated with developing instrumented medical devices and tools [31-36]. Otto Bock HealthCare is the world market leader in prosthetics and is an outstanding system provider of high-quality and technologically sophisticated products and services. Otto Bock has also played a major role in the DARPA "Revolutionizing Prosthetics" Upper Extremity project, and through acquisitions has become highly involved in the field of neurostimulation. The Center for the Intrepid has world-class facilities for the prosthetic fitting, evaluation, gait analysis, and rehabilitation of service members with amputations. The Center for the Intrepid has also collected initial data on the effects of prosthesis malalignment on the kinematics of the non-amputated limb to determine the causality of secondary disabilities.

Published literature provides evidence that individuals with amputations develop debilitating secondary disabilities, as a result of their amputation, to include chronic lower back pain, hip and knee pain, symptomatic osteoarthritis, and decreased bone mineral density in the femoral neck and head of the residual limb [37-42]. These secondary disabilities have a significant negative functional impact on the performance of activities of daily living, recreation, sports, and occupation [43]. The etiologies of these secondary disabilities are not well delineated, however proposed causative factors include gait abnormalities – specifically asymmetric limb loading, increased force transmission through the intact limb, and a poor fit of the amputated limb within the socket. Similarly, symptomatic osteoarthritis of the intact limb's knee has been linked to the increased intact limb loading caused by a limping-type gait in which greater stresses are placed on the intact limb to compensate for decreased loading of the amputated extremity [40]. Pistoning and antero-posterior translational motion of the residual limb within the prosthetic socket are two factors that have been tied to the development of secondary disabilities in the amputated extremity [44]. Currently, the evaluation of prosthetic fitting and limb-socket motion is based predominantly on subjective feedback from patients and limited objective measures such as the use of grease pen markings within the socket, compressible foam, erythema spots on the skin, wear patterns of the prosthesis, and pressure measurements within the socket to identify pressure points [45]. In order to reduce the incidence of secondary disabilities of the non-amputated limb and/or lower back, instrumentation will be developed as part of the MGAS to evaluate the non-amputated limb and ensure symmetric gait and balanced socket forces. The results of this study will lay the groundwork for future studies addressing a wide range of questions including the importance of residual limb closure techniques and methods of prosthetic fitting on limb loading symmetry during gait.

6. RESEARCH DESIGN

The proposed human subjects research will be conducted in the Military Performance Laboratory of the Center for the Intrepid (CFI) at Fort Sam Houston, Texas. The proposed research is a validation and usability study that will use convenience samples of patients being treated at the CFI, un-injured service members, and clinicians. In general, the patients have experienced severe lower extremity trauma resulting in a unilateral transtibial amputation and may have contralateral limb injuries to include peripheral nerve injury, volumetric muscle loss, and burns. Biomechanical data collected during the performance of various functional tasks (i.e. level and inclined gait, stair climbing) using the Mobile Gait Analysis System (MGAS) will be validated using standardized motion-capture biomechanical analysis. The specific population enrolled and collections procedures performed are matched to our Aims which follow the design milestones of the MGAS over its development (see section 3). A total of 21 patients and 14 healthy controls will be recruited and enrolled over the next 3 years. Furthermore, usability and utility data will be collected via structure interviews with patients and clinician follow use of the MGAS. A subgroup (N=14) of the injured service members and their clinicians will be asked to provide feedback on the usability and utility of the MGAS. Fourteen (14) structure interviews (one for each patient in the subgroup) will be performed with recruited treating clinicians experienced in the use of the MGAS.

7. RESEARCH PLAN

7.1 Selection of Subjects

7.1.1. Subject Population.

A total of 3 population groups will be enrolled from convenience samples of patients being treated at the CFI, un-injured service members, and clinicians. The specific population enrolled match to our Aims which follow the design milestones of the MGAS over its development (see section 3). As described in section 7.1.5 the injured service members with unilateral transtibial amputations will be primarily recruited from the patients receiving care at the CFI. Currently over 120 patients who have experienced severe lower extremity trauma are receiving care at the CFI. Healthy, uninjured study volunteers will be recruited from an existing population of service members at Fort Sam Houston that match the general demographics of the patients with lower extremity injuries. The age

range of the injured and uninjured service members will be 18-45 to most closely match the demographics of young, physically fit service members that the MGAS is designed to assist. Clinicians will be recruited from the clinical staff at the CFI experienced in fitting prosthetics and training patients with the MGAS.

7.1.2. Source of Research Material.

All data collected will be obtained for research purposes.

Source of Research Material	Standard Care? (Y/N)
Motion Capture Biomechanical Analysis	N
Mobile Gait Analysis System	N
Usability Feedback Sessions	N
Chart review/Patient History	Y

7.1.3. Inclusion and Exclusion Criteria.

Aim 1. Controls (Appendix B)

Inclusion Criteria

1. Age 18 – 45 years
2. DEERS eligible
3. Independent ambulation on slopes, stairs, and level ground
4. Lower extremity range of motion within normal limits
5. Lower extremity muscle strength within normal limits
6. Reported pain scores less than 5/10
7. Able to comply with instructions associated with motion-capture biomechanical analysis
8. Able to provide written informed consent

Exclusion Criteria

1. Inability to safely ambulate for a minimum of twenty minutes continuously and unassisted
2. Medical or Psychological disease that would limit gait testing (i.e. traumatic brain injury, stroke, renal failure, cardiac or pulmonary disease, severe anemia, unhealed wound, pregnancy etc.)
3. Sustained lower extremity injury through physical trauma (Resulting in limited function due to amputation, burn, or neurologic or musculoskeletal injury)
4. Blindness
5. Active infection
6. Inability to understand instructions/questions given in English
7. Inability to navigate independently in a community environment

Aim 2. Patients Contra Involvement Permitted (Appendix C)

Inclusion Criteria

1. Age 18 – 45 years
2. DEERS eligible
3. Sustained unilateral transtibial amputation
4. Independent ambulation without an assistive device for a minimum of two months
5. Independent ambulation on stairs and slopes for a minimum of one month
6. Reported pain scores less than 5/10
7. Able to comply with instructions associated with motion-capture biomechanical analysis
8. Able to comply with instructions associated with a structured interview
9. Able to provide written informed consent

Exclusion Criteria

1. Inability to safely ambulate for a minimum of twenty minutes continuously and unassisted
2. Medical or Psychological condition that would preclude safe gait testing (i.e. severe traumatic brain injury, stroke, renal failure, cardiac or pulmonary problems disease, severe anemia, unhealed wound, pregnancy etc.)

Version 3, Date: 21 November 2011

3. Use of bracing or orthoses on limb contralateral to amputation
4. Bilateral lower-extremity amputations
5. Blindness
6. Active infection
7. Inability to understand instructions/questions given in English
8. Inability to navigate independently in a community environment

Aims 2 and 4. Clinicians (Appendix D)

Inclusion Criteria

1. Age 18 – 70 years
2. Able to comply with instructions associated with a structured interview
3. Current CFI staff clinician who has used the Mobile Gait Analysis System
4. Able to provide written informed consent

Exclusion Criteria

1. Inability to understand instructions/question given in English
2. Blindness

Aim 3 and 4. Patients Contra Involvement Disallowed (Appendix E)

Inclusion Criteria

1. Age 18 – 45 years
2. DEERS eligible
3. Sustained unilateral transtibial amputation
4. Independent ambulation without an assistive device for a minimum of two months
5. Independent ambulation on stairs and slopes for a minimum of one month
6. Reported pain scores less than 5/10
7. Able to comply with instructions associated with motion-capture biomechanical analysis
8. Able to comply with instructions associated with a structured interview
9. Able to provide written informed consent

Exclusion Criteria

1. Inability to safely ambulate for a minimum of twenty minutes continuously and unassisted
2. Medical or Psychological condition that would preclude safe gait testing (i.e. severe traumatic brain injury, stroke, renal failure, cardiac or pulmonary problems disease, severe anemia, pregnancy etc.)
3. Contralateral limb involvement (i.e. amputation, burns, tissue loss, nerve damage) limiting normal range of motion or strength
4. Blindness
5. Active infection
6. Inability to understand instructions/questions given in English
7. Inability to navigate independently in a community environment

7.1.4. Subject Screening Procedures.

Research staff will work with the clinical staff and local units to identify subjects who are appropriate for the study. Subjects will be contacted in person or by phone (Appendix F) and invited to participate. As part of the study enrollment process the potential subject will be made aware of the study purpose and inclusion/exclusion criteria. Only after all concerns have been addressed and the subject signs the consent form will the subject be considered an enrollee in the protocol. Upon subject enrollment or failure to meet inclusion/exclusion criteria any original contact information will be destroyed. Following consenting, a chart review, follow-up questions, and/or a basic physical exam may be conducted if there are questions about the eligibility of a potential patient or control subject. Consented patient or control subjects found by a BAMC privileged provider not to meet the eligibility criteria will be withdrawn from the study (Appendix K). Consented patient or control subjects found to have medical conditions which may preclude the safe performance of any single study procedure will not perform that procedure. Furthermore, if consented patient or control subjects cannot safely perform a procedure once begun, they will be stopped and proceed to the next study procedure. Clinicians will follow the same subject screening procedures with the exclusion of the chart review, follow-up questions, and/or a basic physical exam.

7.1.5. Description of the Recruitment Process.

Version 3, Date: 21 November 2011

Twenty-one (21) individuals with a unilateral transtibial amputation will be recruited from the CFI. A member of the study team will detail the eligibility requirements to clinical staff whom will assist in identifying CFI patients who may be appropriate for the study.

Fourteen (14) uninjured service members will be recruited from units assigned to Fort Sam Houston in person by study personnel.

Fourteen (14) structure interviews will be performed with recruited treating clinicians experienced in the use of the MGAS. A member of the study team will contact the clinical staff at the CFI in person (Appendix J) to describe the study and invite them to participate. Study personnel do not have supervisory positions over the clinicians whom are free not to participate in this study. It is possible, in fact likely, that given the limited number of treating clinicians experienced in the use of the MGAS that a clinician may choose to participate multiple times. We do, however, anticipate that the clinicians' experiences will vary between fittings due to the unique challenges posed by each patient, therefore making the repeated collection of data useful.

Potential subjects interested in study participation will be asked to call study personnel who will attempt to meet with them directly. In some cases, potential subjects may leave their contact information with their clinician or on a study personnel's voice mail. Either by phone or in person, study personnel will speak with potential subjects to describe the study and determine eligibility (Appendix F and J). If the potential subjects are interested in participation, he/she will meet with a research team member prior to or on the initial day of testing to review and complete written informed consent documents (Appendix B-E). Only after all concerns have been addressed and the subject signs the consent form will the subject be considered an enrollee in the protocol. Upon subject enrollment or failure to meet inclusion/exclusion criteria any original contact information will be destroyed.

7.1.6. Consent Process.

A study team member will be responsible for obtaining informed consent from the subjects. The consenting process will take part in a section of the lab away from other lab activity in order to provide adequate privacy. As part of the consenting process the consentor will allow the subject ample time to read and understand the consent form. At that time the consentor will review the consent document and address any questions from the subject. Only after all concerns have been addressed and the subject agrees to sign the consent form will the subject be considered an enrollee in the protocol (Appendix A).

7.1.7. Compensation for participation.

No compensation will be provided to the subjects as part of this study.

7.2 Drugs, Dietary Supplements, Biologics, or Devices.

7.2.1 N/A

7.2.2

Figure 2 illustrates the proposed Mobile Gait Analysis System (MGAS) using a concept of modular external sensors with wireless communications powered by common cell phone batteries. The MGAS will evolve over its development cycle with initial component testing to be done at the CFI's MPL. Additional components like external shoe-mounted force/torque sensor (Figure 3) and external prosthetic pylon sensors (Figure 4) are still in the prototype stage. Individual components of force are measured with strain gage load sensing elements which are built into frames between the upper and lower flex plates of the shoe-mounted component. Both bending beam and shear type load sensing elements are employed and they are each individually calibrated with test masses before final assembly. The prototype system for measuring the forces in the prosthesis has been initiated by the engineers at Otto Bock HealthCare. This system consists of replacing one of the prosthesis adapters with a specialized force and moment (F/M)

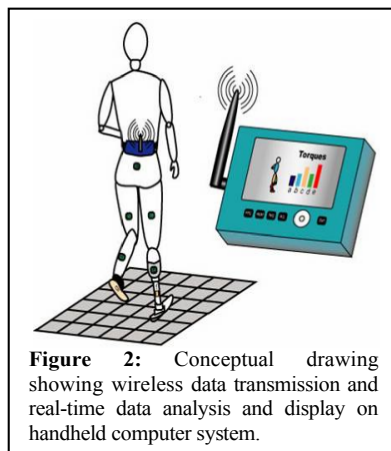
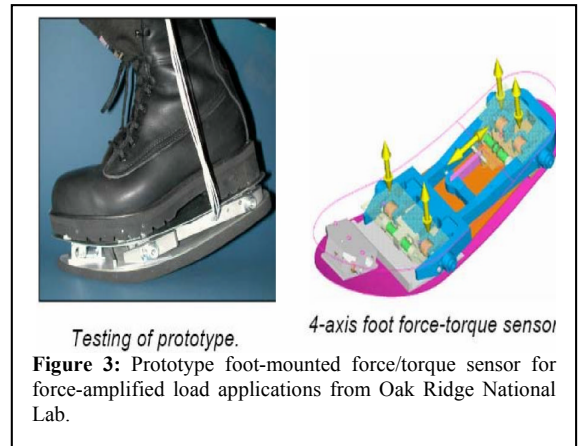

Figure 2: Conceptual drawing showing wireless data transmission and real-time data analysis and display on handheld computer system.



Testing of prototype.

4-axis foot force-torque sensor

Figure 3: Prototype foot-mounted force/torque sensor for force-amplified load applications from Oak Ridge National Lab.

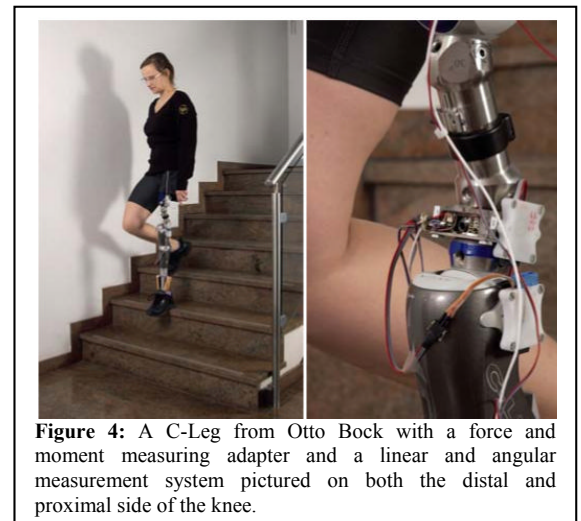

Figure 4: A C-Leg from Otto Bock with a force and moment measuring adapter and a linear and angular measurement system pictured on both the distal and proximal side of the knee.

sensor adapter modified to be more sensitive to the applied loads and instrumented with strain gages to measure these loads. In conjunction with this, two separate elements containing single-axis rate gyros and a dual-axis accelerometer have been used to determine flexion angles and linear accelerations.

All MGAS components are commercially available external sensors that will be used as they were intended. As a system comprised of external sensors which do not control prosthetic function, the MGAS does not pose a significant risk to the human subjects. Therefore, the MGAS should not require a submission of an IDE application to FDA for approval. Instead, the MGAS's risks should be accessed directly by BAMC's IRB.

It is possible that MGAS sensors attach via Velcro straps may cause discomfort and need to be adjusted to alleviate any discomfort. Also, the shoe-mounted force/torque sensor will add approximately 0.5 inch of height to subjects' shoes. It is possible that the addition of this sensor may alter gait stability. However, the shoe-mounted force/torque sensor will be coated in anti-slip material similar to the sole of a shoe (Figure 3). Furthermore, the shoe-mounted force/torque sensor is designed to be flexible and conform to the subject's shoe as not to be perceptible or affect gait. Finally, the MGAS will be powered by common cell phone batteries which have low risk of shock should electrical failure occur.

7.3. Study Procedures/Research Interventions.

Aim 1. The healthy control subjects will attend one (1) data collection session of approximately 4 hours in duration at the MPL. The 4 hour session consists of: 1) subject enrollment, medical history, and medical status procedures prior to data collection, 2) MGAS sensor placement, 3) standard motion capture marker placement, 4) trials of level ground walking, inclined walking, and stair climbing, 5) rest breaks, 6) MGAS adjustments and data downloads, and 7) removal of MGAS sensors and motion capture markers. The subjects, while wearing the MGAS and standard motion-capture markers, will perform several trials of level ground walking, inclined walking, and stair climbing (see 7.3.2 for detailed procedures). Subjects will perform short bouts of level ground walking, inclined walking, and stair climbing lasting approximately 5-10 minutes. Subjects will be instructed to inform study personnel when they require a rest. Between bouts, the MGAS may need to be adjusted or have data downloaded. We anticipate that subjects will only be physically active for a total of approximately (1) one hour. These physical activities pose no additional risks to the subjects and are similar to activities they would experience in daily living. Stairs and inclines have rails in which patients can utilize to assist during these tasks.

Aim 2. The patient and clinician subjects will attend two (2) data collection sessions of approximately 4 hours in duration at the MPL. The 4 hour sessions consists of: 1) subject enrollment, medical history, and medical status procedures prior to data collection, 2) MGAS sensor placement, 3) standard motion capture marker placement, 4) trials of level ground walking, inclined walking, and stair climbing, 5) rest breaks, 6) MGAS adjustments and data downloads, 7) removal of MGAS sensors and motion capture markers, and 8) a structure interview. The clinician will fit and align the patient's prosthetic using the MGAS. The fitting and alignment process will be filmed with a video camera to document its usability. The patient subjects wearing the MGAS and standard motion-capture markers will perform several trials of level ground walking, inclined walking, and stair climbing (see 7.3.2 for detailed procedures). Patient subjects will perform short bouts of level ground walking, inclined walking, and stair climbing lasting approximately 5-10 minutes. Subjects will be instructed to inform study personnel when they require a rest. Between bouts, the MGAS may need to be adjusted or have data downloaded. We anticipate that patient subjects will only be physically active for a total of approximately (1) one hour per session. These physical activities pose no additional risks to the patient subjects and are similar to activities they would experience in daily living or during physical rehabilitation. Stairs and inclines have rails in which patient subjects can utilize to assist during these tasks. Following motion-capture, the patient and clinician will separately participate in a structure interview (Appendix I2-I3) to comment on the usability and utility of the MGAS. Data collection will be scheduled for two 4 hour sessions to occur within 7 days of each other. Final prosthetic fit and alignment will be determined solely by the prosthetist (clinician) in their profession judgment using standard clinical practice techniques and/or the MGAS.

Aim 3. The patient subjects will attend two (2) data collection sessions of approximately 4 hours in duration at the MPL to include rest breaks. The 4 hour sessions consists of: 1) subject enrollment, medical history, and medical status procedures prior to data collection, 2) MGAS sensor placement, 3) standard motion capture marker placement, 4) trials of level ground walking, inclined walking, and stair climbing, 5) rest breaks, 6) MGAS adjustments and data downloads, and 7) removal of MGAS sensors and motion capture markers. The fitting and alignment process will be filmed with a video camera to document its usability. After each alignment change, the patient subjects wearing the MGAS and standard motion-capture markers will perform several trials of level ground walking, inclined walking, and stair climbing (see 7.3.2 for detailed procedures). Patient subjects will perform short bouts of level ground walking, inclined walking, and stair climbing lasting approximately 5-10 minutes. Subjects will be instructed to inform study personnel when they require a rest. Between bouts, the MGAS may need to be adjusted or have data downloaded. We anticipate that patient subjects will only be physically active for a total of approximately (1) one hour per session. These physical activities pose no additional risks to the patient subjects and are similar to activities they would experience in daily living or during physical

rehabilitation. Stairs and inclines have rails in which patient subjects can utilize to assist during these tasks. Data collection will be scheduled for two 4 hour sessions to occur within 7 days of each other. Final prosthetic fit and alignment will be determined solely by the prosthetist (clinician) in their profession judgment using standard clinical practice techniques and/or the MGAS.

Aim 4. The patient and clinician subjects will attend two (2) data collection sessions of approximately 4 hours in duration at the MPL. The 4 hour sessions consists of: 1) subject enrollment, medical history, and medical status procedures prior to data collection, 2) MGAS sensor placement, 3) standard motion capture marker placement, 4) trials of level ground walking, inclined walking, and stair climbing, 5) rest breaks, 6) MGAS adjustments and data downloads, 7) removal of MGAS sensors and motional capture markers, and 8) a structure interview. The clinician will fit and align the patient's prosthetic using the MGAS. The fitting and alignment process will be filmed with a video camera to document its usability. The patient subjects wearing the MGAS and standard motion-capture markers will perform several trials of level ground walking, inclined walking, and stair climbing (see 7.3.2 for detailed procedures). Patient subjects will perform short bouts of level ground walking, inclined walking, and stair climbing lasting approximately 5-10 minutes. Subjects will be instructed to inform study personnel when they require a rest. Between bouts, the MGAS may need to be adjusted or have data downloaded. We anticipate that patient subjects will only be physically active for a total of approximately (1) one hour per session. These physical activities pose no additional risks to the patient subjects and are similar to activities they would experience in daily living or during physical rehabilitation. Stairs and inclines have rails in which patient subjects can utilize to assist during these tasks. Following motion-capture, the patient and clinician will separately participate in a structure interview (Appendix I2-I3) to comment on the usability and utility of the MGAS. Data collection will be scheduled for two 4 hour sessions to occur within 7 days of each other. Final prosthetic fit and alignment will be determined solely by the prosthetist (clinician) in their profession judgment using standard clinical practice techniques and/or the MGAS.

Table 1. Assessment/date collection elements by aims and subject population.

Assessment	Aim 1. Controls	Aim 2. Patients	Aim 2. Clinicians	Aim 3. Patients	Aim 4. Patie	Aim 4. Clinicians
Study Day / period	Day 1 (4 hours)	Day 1-2 (4 hours each)*	Day 1-2 (4 hours each)*	Day 1-2 (4 hours each)*	Day 1-2 (4 hours each)*	Day 1-2 (4 hours each)*
Informed Consent, Discuss plan, etc.	x	x (Day 1)	x (Day 1)	x (Day 1)	x (Day 1)	x (Day 1)
Demographics, Medical History, Medications & Physical	x	x (Day 1)		x (Day 1)	x (Day 1)	
Prosthetic Fitting and Alignment		x	x (of patient)	x	x	x (of patient)
MGAS Placement	x	x	x (on patient)	x	x	x (on patient)
Motion-Capture Marker Placement	x	x		x	x	
Level Ground Walking	x	x		x	x	
Incline Walking	x	x		x	x	
Stair Climbing	x	x		x	x	
Structured Interview		x	x	x	x	x

* Data not collection on Day 1 will be collected on Day 2 to occur within 7.

7.3.1 Collection of Human Biological Specimens. N/A

7.3.1.1 Laboratory evaluations and special precautions. N/A

7.3.1.2 Specimen storage. N/A

7.3.2 Data Collection.

Table 1 in section 7.3 describes which assessments and specific data collection procedures will be performed based on the Specific Aim and Subject Population. Below we describe each assessment and specific data collection procedure.

Demographics, Medical History, Medications & Physical

Once the controls and patients are consented and enrolled, a study specific medical history and physical exam will be completed (Appendix H). Clinicians will follow the same subject screening procedures with the exclusion of the chart review, follow-up questions, and/or a basic physical exam.

Prosthetic Fitting and Alignment and MGAS Placement

In Aim 1, only the sensor components will be placed on the control subject via Velcro straps similar to the motion-capture marker placement describe below. In later aims, the full Mobile Gait Analysis System (MGAS) will be worn by the patients. Figure 2 in section 7.2.2 illustrates the proposed MGAS using a concept of modular sensors with wireless communications. Alignment and fitting of the patient's prosthetics will be performed by clinicians using the MGAS. This system represents a new approach to prosthesis alignment, fitting, and patient rehabilitation and will allow subjects to experience more natural and efficient function from their prosthetic limbs and reduce secondary disabilities. The steps in this new methodology are shown in Figure 5. It will enhance the maintenance and performance of long-term prosthesis and socket performance/fit by increasing the ease of measurement of prosthesis performance. Mobile gait analysis also represents an evidence-based approach to prosthesis fitting and will allow wider use of evidence-based rehabilitation techniques. During Aim 3, multiple alignments will be tested while the subjects perform level, walking, slope walking, and stair climbing. Final prosthetic fit and alignment will be determined solely by the prosthetist (clinician) in their profession judgment using standard clinical practice techniques and/or the MGAS.

Motion-Capture Biomechanical Analysis

A comprehensive motion-capture biomechanical analysis will be used to assess performance during **level walking, inclined walking, and stair climbing**. A 24 camera optoelectronic motion capture system (Motion Analysis Corp., Santa Rosa, CA) operating at 120 Hz and 57 reflective markers placed on the subjects will be used to collect full body kinematic data. The motion-capture reflective markers will be placed on the upper/lower extremities, head, trunk and prosthesis to track their motions (figure 6). A digitizing process will be used to determine anatomical coordinate system definitions for all segments in accordance with International Society of Biomechanics standards. Visual 3D software (C-Motion Inc., Rockville, MD) will be used to determine segment and joint angles and displacements using an Euler angle approach. Forces at the foot-floor interface (ground reaction forces) will be collected at 1200 Hz using eight force plates (AMTI, Inc., Watertown, MA) imbedded in the floor or 2 force plates in the slope/stairs. Motion data will be combined with anthropometric and ground reaction force data to calculate joint torques and powers using an inverse dynamic approach via the Visual-3D software package (C-motion Inc., Rockville, MD).

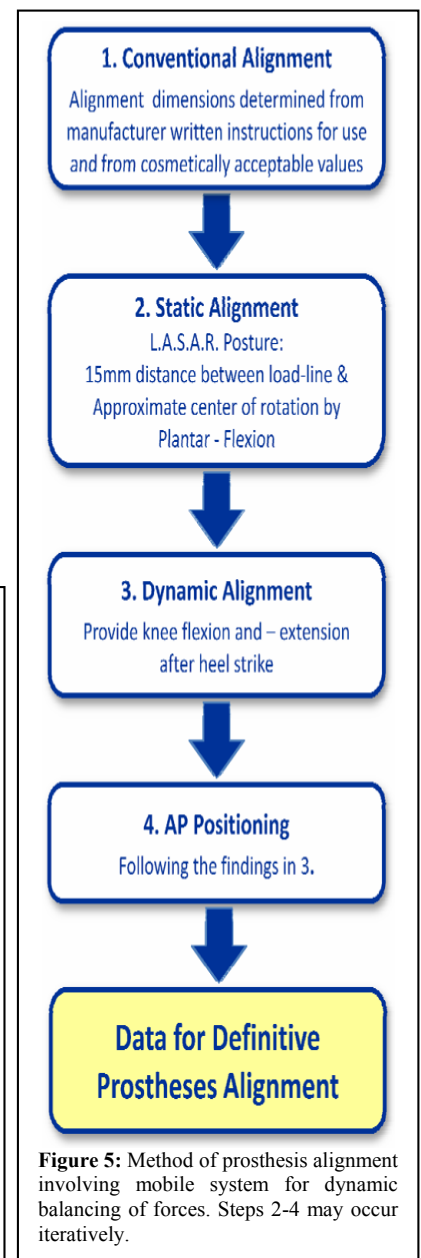

Specific tasks to be performed:

- Overground level ambulation
 - At three controlled speeds
- Incline ambulation at a 10 degree slope
 - At two controlled speeds
- Stair ambulation
 - At one controlled speed

A total of five trials providing complete kinematic and kinetic data will be collected for overground level ambulation, incline ambulation, and stair ambulation at each control speed. The mean of the five trials will be used to represent the variable of interest for each subject. A successful trial will consist of a step in which the foot lands within the boundaries of the force plates on the walking surface with only the feet touching the structure. Subjects will be observed to ensure they do not target the force plates while performing slope ambulation tasks. An automated auditory cue will be generated during ambulation to ensure that the subject

Version 3, Date: 21 November 2011

ambulates at the pre-determined walking velocities. For stairs, the subjects will ambulate at a controlled cadence of 80 steps per minute. To minimize the effect of fatigue a five minute break will be provided after completion of each testing condition or more frequently if requested by the subject.

In addition to the data collected using a motion analysis system and force platforms, data will be also be collected using the MGAS. The data collected from the MGAS will be compared to the data collected by the motion analysis system and force platforms to check the validity of the data collected on the MGAS. Collection of MGAS from the device while the subject is performing the previously described activities will require no additional time or effort. The testing sessions will also be recorded by two normal digital video cameras. Video data will be stored in a locked file cabinet or on a password protected computer and will be used if there is difficulty interpreting data collected using the digital infrared cameras.

Structured Interview

A structured interview will be conducted with each of the patients and clinicians at the end of the project to provide further insight into the specific types of problems encountered during use of the device. The interview will be recorded using a video camera connected to a laptop running Morae 3.2 (Techsmith, <http://www.techsmith.com/morae.asp>). This software is designed for usability testing and market research. It can capture audio, video, and annotations made by the moderator. This software can also automatically calculate metrics and graphs for analysis and reporting. Examples of the Patient and Clinician structured interview question can be found in Appendices I2-I3.

7.3.3. Human Biological Specimens/Tissue/Data Banking. N/A

7.4 Statistical Consideration

7.4.1 Sample Size Estimation.

This investigation is an initial validation of the Mobile Gait Analysis System's data. The data collected in this study will guide future testing of the Mobile Gait Analysis System. Given our experience in the assessment of individuals with amputation, we believe multiple trials in a limited number of individuals during controlled activities will be of greater value than data from a larger group of individuals. Once the final version of the Mobile Gait Analysis System is available, future large scale testing in a variety of injured individuals will be warranted.

	Controls	Patients	Clinicians (#Feedback Sessions)
Estimate Required Sample Size	10	15	14
Estimate Participant Drop Out	3	5	0
Estimate Participant Withdrawal	1	1	0
Total Enrollment Requirement	14	21	14

Enrollment at Each Site	Controls	Patients	Clinicians (#Feedback Sessions)
BAMC	14	21	14

7.4.2 Primary (i.e., primary outcome variables) and secondary endpoints.

The following biomechanical and usability assessments will be used to track the overall performance of the Mobile Gait Analysis System:

Biomechanical Motion Analysis and Mobile Gait Analysis System

Intact and prosthesis limb:

- Kinematics
- Kinetics
- Ground reaction forces
- Socket forces (only prosthesis)

Structured Interviews

- Usability and utility from patient feedback
 - Comfort
 - Time taken to be fitted
 - Ease of movement
 - Ability to adapt to prosthesis
- Usability and utility from clinician feedback
 - Time taken to fit
 - Ease of use
 - Comparison to conventional methods

7.4.3 Data analysis.

Kinematic and kinetic data will be collected from the laboratory motion analysis and Mobile Gait Analysis Systems for each activity described above. Descriptive statistics will be calculated for each variable and compared. Paired t-tests of peak values will be used to determine any magnitude and timing differences observed in the Mobile Gait Analysis System data. Data will be further assessed to determine the magnitude and types of errors and determine if they are likely due to calibration, sensor, or procedural flaws (e.g. consistent differences between systems across activities may indicate differences associated with baseline alignment, while spikes in the data or inconsistent results may be due to hardware issues etc.).

Audio and video recording of subject comments will be annotated for each interview question using the Morae 3.2 software. Trends in responses across subjects and overall level of satisfaction will be quantified via descriptive statistics.

7.7 Confidentiality.

All records pertaining to a subject's involvement in this research study will be stored in a locked room within a locked filing cabinet. A subject number will indicate the subject's identity on these records. A master sheet linking subject names and their subject numbers will be kept secure by the principle investigator and will not be shown to anyone except for the investigators in this study or governmental agencies only in accordance with federal law.

All subject records will be kept in the Military Performance Lab at the Center for the Intrepid. Data will be stored in a locked file cabinet and password protected computer. Data from each testing session will be labeled and stored according to a time date code (YYYYMMDDTTTT). A key matching each data collection session code to an individual subject will be stored on a password protected computer and in paper format in a locked file cabinet separate from subject data. Access to the data for processing and subject tracking will be limited to members of the research team.

Random checks of 10% of the individual records will be conducted to insure that electronically stored data is identical to the data recorded on collection forms (Appendix H-I). All subject information will be handled in a confidential manner consistent with HIPPA policies. Subjects will not be specifically identified in any publication of research results. However, in unusual cases, the research records may be inspected by appropriate government agencies or be released in response to an order from a court of law.

7.7.1 Certificate of Confidentiality. N/A

8.0 RISKS/BENEFITS ASSESSMENT

8.1 Risks.

All study interventions are noninvasive and of minimal potential risk. Following consenting, a chart review, follow-up questions, and/or a basic physical exam may be provided if there are questions about the eligibility of a potential subject. Consented subjects found to not meet the eligibility criteria will be withdrawn from the study. Consented subjects found to have medical conditions which may preclude the safe completion of any single study procedure will not complete that procedure. Furthermore, if consented subjects cannot safely perform a procedure once begun, they will be stopped and proceed to the next study procedure.

. During data collection sessions, subjects will perform short bouts of level ground walking, inclined walking, and stair climbing lasting approximately 5-10 minutes. We anticipate that subjects will only be physically active for a total of approximately (1) one hour per session. Throughout testing, we expect subjects to experience some fatigue. Subjects will be instructed to inform a member of the research team if they experience fatigue during testing which would require a rest break. The subject will then be allowed to rest until he or she is comfortable or decides to discontinue participation in the test. All MGAS components are commercially available external sensors that will be used as they were intended. The MGAS is comprised of external sensors which do not control prosthetic function and are highly unlikely to cause prosthetic failure. The shoe-mounted force/torque sensor will add approximately 0.5 inch of

Version 3, Date: 21 November 2011

height to subjects' shoes. It is possible that the addition of this sensor may alter gait stability. However, the shoe-mounted force/torque sensor will be coated in anti-slip material similar to the sole of a shoe. Furthermore, the shoe-mounted force/torque sensor is designed to be flexible and conform to the subject's shoe as not to be perceptible or affect gait. Final prosthetic fit and alignment will be determined solely by the prosthetist (clinician) in their professional judgment using standard clinical practice techniques and/or the MGAS. Gait and stability impairments are common in patient populations and can be present in healthy populations. These physical activities pose no additional risks to the subjects and are similar to activities they would experience in daily living to include physical rehabilitation. Stairs and inclines have rails in which subjects can utilize to assist during these tasks.

A secondary risk in which subject may experience is mild discomfort during the removal of double-sided tape used to apply markers. There is also risk for possible allergic reaction/skin irritation from the adhesive from the double sided tape. It is possible that MGAS sensors attach via Velcro straps may cause discomfort and need to be adjusted to alleviate any discomfort. The MGAS will be powered by common cell phone batteries which have low risk of shock should electrical failure occur.

All data collected will be de-identified before reporting to our consultants.

There may also be unforeseen risks associated with this study. Consistent with standard practice, subjects will be able to discontinue participation in the study at any time.

8.2 Potential Benefits.

There is no guarantee that subjects will benefit from their participation in this study. It is hoped that the study will benefit patients receiving care at the CFI by guiding the development of a new clinical tool for prosthetic alignment and to guide the rehabilitation of individuals with amputations.

9.0 ADVERSE EVENTS, UNANTICIPATED PROBLEMS, AND DEVIATIONS

9.1 Risks to subjects participating in the study should not increase beyond those present in activities performed during daily living. The primary risk associated with this protocol is the risk of falling due to fatigue, MGAS use, prosthetic fit, and impaired gait stability. A fall may be an adverse event depending on its severity. Skin breakdown on the injured limb due to poor prosthetic fit, health of skin, orthopedic equipment, or other unanticipated source is a potential but unlikely example of an adverse event. The subject will be informed to indicate in person, or when not immediately evident, inform over the phone if any adverse event occurs. The event will be monitored and immediately reported to the BAMC IRB in accordance with the governing policy and procedures. If necessary, appropriate medical or professional intervention will be arranged by the principal investigator or a member of the research team (AI or PI). In addition, a report of the adverse event will be to the BAMC IRB as required.

9.2 Reporting Unanticipated Problems Involving Risks to Subjects or Others, Serious Adverse Events and Deaths to the Office of the IRB, BAMC.

All unanticipated problems involving risk to subjects or others, serious adverse events, and all subject deaths will be reported within three (3) business days by phone (210-916-0607), by e-mail (BAMC_IRB_AE@amedd.army.mil), by facsimile (210-916-1650) or via letter addressed to Human Protections Administrator, Office of the Institutional Review Board, Department of Clinical Investigation, Brooke Army Medical Center, 3400 Rawley E Chambers Ave, Bldg 3667, Fort Sam Houston, TX 78234-6315. A complete written report will follow the initial notification.

9.3 Medical Monitor.

The medical monitor will review all unanticipated problems involving risk to subjects or others, serious adverse events and all subject deaths associated with the protocol and provide an unbiased written report of the event to the HQ, USAMRMC IRB. The medical monitor will comment on the outcomes of the event or problem and in the case of a serious adverse event or death comment on the relationship to participation in the study. The medical monitor will also indicate whether he/she concurs with the details of the report provided by the study investigator. Reports for events determined by either the investigator or medical monitor to be possibly or definitely related to participation and reports of events resulting in death will be promptly forwarded to the OIRB, BAMC.

10.0 WITHDRAWAL FROM STUDY PARTICIPATION.

A subject may choose at any time to decline completing a part of the study by informing a research team member of the decision. The subject may also choose to withdraw entirely at any time. If a subject chooses to withdraw, his or her participation will end at that

point but the decision will not affect eligibility for care or any other benefits to which the subject is entitled. Participation may also be ended prior to completing the study if the supervising clinical research member feels the subject's safety or healthy is at risk for any reason.

11.0 USAMRMC Volunteer Registry Database. N/A

12.0 REFERENCES.

- [1] Gawande A. Notes of a Surgeon Casualties of War — Military Care for the Wounded from Iraq and Afghanistan. *N Engl J Med.* 2004 351;24. 2473-2475.
- [2] Vickers DR, Palk C, McIntosh AS, Beatty KT. Elderly unilateral transtibial amputee gait on an inclined walkway: A biomechanical analysis, *Gait & Posture.* 2007, doi: 10.101 6/j .gaitpost.2007.06.08.
- [3] Miff SC, Childress DS, Gard SA, Meier MR, Hansen AH. Temporal symmetries during gait initiation and termination in nondisabled ambulators and in people with unilateral transtibial limb loss. *J. Rehab. Res. and Dev.* 2005;42 (2), 175-182.
- [4] Quesada PM, Pitkin M, Colvin J. Biomechanical Evaluation of a Prototype Foot/Ankle Prosthesis. *IEEE Trans. on Rehab. Eng.* 2000;8(1), 156-159.
- [5] Buckley JG, ODriscoll D, Bennett SJ. Postural Sway and Active Balance Performrance in Highly Active Lower-Limb Amputees. *Am. J. Physcial Medicine and Rehabilitation.* 2002;81(1), 13-20.
- [6] Schmalz T, Blumentritt, Marx B. Biomechanical analysis of stair ambulation in lower limb amputees. *Gait & Posture.* 2007;25, 267-278.
- [7] Gard SA. Use of Quantitave Gait Analysis for the Evaluation of Prosthetic Walking Performance. *J. Prosthetics and Orthotics.* 2006;18(1S) 93.
- [8] Hofstad CJ, van der Linde H, Nienhuis B, Eng M, Weerdesteyn V, Duysens J, Geurts AC. High Failure Rates When Avoiding Obstacles During Treadmill Walking in Patients With a Transtibial Amputation. *Arch Phys Med Rehabil.* 2006;87, 1115-1122.
- [9] Ebrahimzadeh MH, Rajabie MT. Long-term Outcomes of Patients Undergoing War-related Amputations of the Foot and Ankle. *J Foot Ankle Surg.* 2007;46(6), 429-433.
- [10] Han TR, Chung SG, Hi S. Gait Patterns of Transtibial Amputee Patients Walking Indoors Barefoot. *Am J Phys Med Rehabil.* 2003;82(2), 96-100.
- [11] Dou P, Jia X, Suo S, Wang R, Zhang M. Pressure distribution at the stump/socket interface in transtibial amputees during walking on stairs, slope and non-flat road. *Clinical Biomechanics.* 2006;21, 1067-1073.
- [12] Dennis DA, Komistek RD, Mahfouz MR, Outten JT, Sharma A. Mobile-bearing total knee arthroplasty: do the polyethylene bearings rotate? *Clin Orthop Relat Res.* 2005;440, 88-95.
- [13] Segal AD, Orendurff MS, Klute GK, McDowell ML, Pecoraro JA, Shofer J, Czerniecki JM. Kinematic and kinetic comparisons of transfemoral amputee gait using C-Leg and Mauch SNS prosthetic knees. *J. of Rehabil Res and Dev.* 2006: 43(7), 857-870.
- [14] Lee WCC, Zhang M, Chan PPY, Boone DA. Gait Analysis of Low-Cost Flexible-Shank Transtibial Prosthesis. *IEEE Trans on Neural Systems and Rehabilitation Engineering.* 2006;14(3) 370-377.
- [15] Kaufman KR, Levine JA, Brey RH, McCrady SK, Padgett DJ, Joyner MJ. Energy expenditure and activity of transfemoral amputees using mechanical and microprocessor- controlled prosthetic knees. *Arch Phys Med Rehabil.* 2008 Jul; 89(7): 1380-5.
- [16] Kaufman KR, Levine JA, Brey RH, Iverson BK, McCrady SK, Padgett DJ, Joyner MJ. Energy expenditure and activity of transfemoral amputees using mechanical and microprocessor- controlled prosthetic knees. *Gait Posture.* 2007 Oct;26(4):489-93.
- [17] Gard SA, Konz RJ. The effect of a shock-absorbing pylon on the gait of persons with unilateral transtibial amputation. *J Rehabil Res Dev.* 2003 Mar-Apr;40(2): 109-24.
- [18] Schmalz T, Blumentritt S, Marx B. Biomechanical analysis of stair ambulation in lower limb amputees. *Gait Posture.* 2007 Feb;25(2):267-78.
- [19] Ossur hf. Grjóthálsi 5, 110 Reykjavík, Iceland.
- [20] Dynastream Innovations, Inc., 228 River Avenue, Cochrane, AB T4C 2C1, Canada.

- [21] Berme N, Lawes P, Solomonidis S, Paul JP. A Shorter Pylon Transducer for Measurement of Prosthetic Forces and Moments During Amputee Gait. *Eng Med*. 1976; 4: 6-8.
- [22] Martinez-Villalpando EC, Herr H, Farrell M. Estimation of ground reaction force and zero moment point on a powered ankle-foot prosthesis. *Conf Proc IEEE Eng Med Biol Soc*. 2007;2007:4687-92.
- [23] Au S, Berniker M, Herr H. Powered ankle-foot prosthesis to assist level-ground and stair- descent gaits. *Neural Netw*. 2008 May;21(4):654-66. Epub 2008 Apr 26.
- [24] Bamberg SJ, Benbasat AY, Scarborough DM, Krebs DE, Paradiso JA. Gait analysis using a shoe-integrated wireless sensor system. *IEEE Trans Inf Technol Biomed*. 2008 Jul; 12(4):4 13-23.
- [25] Zhu HS, Maalej N, Webster JG, Tompkins WJ, Bach-y-Rita P, Wertsch JJ. Foot pressure distribution during walking and shuffling. *Arch Phys Med Rehabil*. 1991 May;72(6):390-7.
- [26] Zhu HS, Harris GF, Wertsch JJ, Tompkins WJ, Webster JG. A microprocessor-based data- acquisition system for measuring plantar pressures from ambulatory subjects. *IEEE Trans Biomed Eng*. 1991 Jul;38(7):710-4.
- [27] Vildjiounaite E, Malm E. -J., Kaartinen J, Alahuhta P. Location estimation indoors by means of small computing power devices, accelerometers, magnetic sensors, and map knowledge. *Lect. Notes Comput. Sci*. 2002. 14: 211–224.
- [28] Pappas IP, Popovic MR, Keller T, Dietz V, Morari M. A reliable gait phase detection system. *IEEE Trans Neural Syst Rehabil Eng*. 2001 Jun;9(2):1 13-25.
- [29] Ericson MN, Bobrek M, Bobrek A, Britton CL, Rochelle JM, Blalock BJ, and Schultz RL, “A High Resolution, Extended Temperature Sigma Delta ADC in 3.3V 0.5 μ m SOS-CMOS,” *Proceedings of the 2004 IEEE Aerospace Conference*, March 6-14, 2004, Big Sky, MT
- [30] Yu Z, McKnight TE, Ericson MN, et al. Vertically aligned carbon nanofiber array: A new type of microelectrode array for electrophysiological recording, *Journal of Neurotrauma*, 24 (7): 1235-1235 P22, July 2007.
- [31] Ericson MN, Wilson MA, Coté GL, Baba JS, Xu W, Bobrek M, Britton CL, Hileman MS, Moore MR, M.S. Emery, and R. Lenarduzzi, “Implantable sensor for blood flow monitoring after transplant surgery,” *Minimally Invasive Therapy & Allied Technologies*, 13(2), April 2004, pp. 87-94 (invited).
- [32] Yu Z, McKnight TE, Ericson MN, et al. “Vertically aligned carbon nanofiber arrays record electrophysiological signals from hippocampal slices,” *Nanoletters*, 7 (8): 2188-2195, August 2007
- [33] *Biocompatible MEMS Electrode Array for Determination of Three-Dimensional Strain*, Evans BM, Mahfouz MR, Pritchard ER, Proceedings of the 28th Annual International Conference of the IEEE Aug. 2006 Page(s):4092 - 4095
- [34] Evans BM, Thundat TG, Komistek RD, Dennis DA, Mahfouz MR. In-vivo orthopedic implant diagnostic device for sensing load, wear, and infection. United States Patent 7,097,662. August 29, 2006.
- [35] *Preliminary Results From Laboratory Tests Of A Prototype Catheter For Monitoring Cell Delivery Into The CNS*, H. L. Fillmore, S. W. Allison, B. M. Evans, S. M. Goedeke, P. R. Boudreaux, G. T. Gillies, University of Virginia Report No.UVA/640419/MAE06/101, March 2006.
- [36] *Computational Model To Predict Changes In In Vivo Kinetic Effects Due To Component Malalignment In Total Knee Arthroplasty*, Evans III BM, Outten JT, Komistek RD, Mahfouz MR International Society for Technology in Arthroplasty 2004 Symposium
- [37] Stam, H.J., A.M. Dommissie, and H.J. Bussmann, Prevalence of low back pain after transfemoral amputation related to physical activity and other prosthesis-related parameters. *Disabil Rehabil*, 2004. 26(13): p. 794-797.
- [38] Lemaire, E.D. and F.R. Fisher, Osteoarthritis and elderly amputee gait. *Arch Phys Med Rehabil*, 1994. 75(10): p. 1094-9.
- [39] Ehde, D.M., et al., Back pain as a secondary disability in persons with lower limb amputations. *Arch Phys Med Rehabil*, 2001. 82(6): p. 73 1-4.
- [40] Norvell, D.C., et al., The prevalence of knee pain and symptomatic knee osteoarthritis among veteran traumatic amputees and nonamputees. *Arch Phys Med Rehabil*, 2005. 86(3): p. 487-93.
- [41] Royer, T. and M. Koenig, Joint loading and bone mineral density in persons with unilateral, trans-tibial amputation. *Clin Biomech (Bristol, Avon)*, 2005. 20(10): p. 1119-1125.
- [42] Miller, W.C., A.B. Deathe, and J. Harris, Measurement properties of the Frenchay Activities Index among individuals with a lower limb amputation. *Clin Rehabil*, 2004. 18(4): p. 4 14-22.
- [43] Legro, M.W., et al., Prosthesis evaluation questionnaire for persons with lower limb amputations: assessing prosthesis-related quality of life. *Arch Phys Med Rehabil*, 1998. 79(8): p. 93 1-8.
- [44] Czerniecki, J.M., *Rehabilitation in limb deficiency. I. Gait and motion analysis*. *Arch Phys Med Rehabil*, 1996. 77(3 Suppl): p. S3-8.

13.0 TIME REQUIRED TO COMPLETE THE RESEARCH (including data analysis).

Aim 1: To validate the Mobile Gait Analysis System initial hardware components.

Aim 1a: To evaluate orientation hardware component function.

- Months: 1-3

Aim 1b: To evaluate shoe-mounted ground reaction force measuring system function.

- Months: 12-14

Aim 2: To determine the clinical utility of a prototype Mobile Gait Analysis System in a patient population.

Aim 2a: To validate the biomechanical data from the Mobile Gait Analysis System in a patient population.

- Months: 6-11

Aim 2b: To determine the usability and utility of Mobile Gait Analysis System from the perspective of patients.

- Months: 9-11

Aim 2c: To determine the usability and utility of Mobile Gait Analysis System from the perspective of clinicians.

- Months: 9-11

Aim 3: To determine the clinical utility of the Mobile Gait Analysis System's alignment function in a patient population.

- Months: 17-23

Aim 4: To determine the clinical utility of the FINAL Mobile Gait Analysis System in a patient population.

Aim 4a: To validate the biomechanical data from the Mobile Gait Analysis System in a patient population.

- Months: 23-29

Aim 4b: To determine the usability and utility of Mobile Gait Analysis System from the perspective of patients.

- Months: 23-29

Aim 4c: To determine the usability and utility of Mobile Gait Analysis System from the perspective of clinicians.

- Months: 23-29

Manuscripts preparation and submissions

- Months: 24-26

14.0 STUDY CLOSURE PROCEDURES

A closure report will be file with the Department of Clinical Investigation at the conclusion of the study. Consent forms and HIPAA forms will be retained in accordance with requirements set forth by the Department of Clinical Investigation. All data, having been de-identified during data collections, will be retained indefinitely.

Appendix 4: IRB protocol approval memos



**DEPARTMENT OF THE ARMY
BROOKE ARMY MEDICAL CENTER
3851 ROGER BROOKE DR.
FORT SAM HOUSTON, TX 78234**

REPLY TO
ATTENTION OF:

MCHE-CI

March 5, 2012

MEMORANDUM FOR: Jason Wilken, PT, PhD
FROM: Brooke Army Medical Center (BAMC) Institutional Review Board

PROJECT TITLE: [369345-1] Development of a Mobile Gait Analysis System for Lower-Limb Amputee High-Level Activity Rehabilitation

REFERENCE #: C.2012.003d
SUBMISSION TYPE: New Project

ACTION: APPROVED
IRB APPROVAL DATE: December 7, 2011
APPROVAL DATE: December 7, 2011
EXPIRATION DATE: December 7, 2012
REVIEW TYPE: Full Committee Review

1. Congratulations! The Brooke Army Medical Center (BAMC) Institutional Review Board (IRB) reviewed and APPROVED your aforementioned protocol and supporting documents on December 7, 2011. The research is judged to constitute Minimal Risk. The protocol has been assigned control number C.2012.003d. Please refer to this designation in all correspondence.

Your protocol was reviewed for regulatory compliance under Full Committee Review, in accordance with 32CFR§219.109(a). Applicable OHRP (under 45CFR46), FDA (under 21CFR§50 and 56) and HIPAA (45CFR§160 and 164) regulations were also consulted, as appropriate. This action will be reported in the minutes of the December 2011 IRB meeting.

2. The following determinations were made as part of the approval process:

- a. The protocol (Version 3, Date: 21 Nov 2011) is approved to enroll up to 21 transtibial amputees, 14 uninjured (control) service members and 14 clinicians.
- b. An informed consent process has been approved in accordance with (IAW) 32 CFR§219.116. Three informed consent documents have been approved. Use of a written, informed document is approved which encompasses all of the required elements of informed consent. The signature of each subject on the informed consent document is required IAW 32 CFR§219.117. Federal regulations also require each participant receive a copy of the consent document. The stamped, IRB-approved consent form's (Version 2, Date: 20 Nov 2011- Patient; Version 2, Date: 20 Nov 2011 - Control; Version 1, Date: 18 Aug 2011 - Clinicians) must be used for enrolling subjects.
- c. A HIPAA Authorization (Version 2, Date: 20 Nov 2011) has been submitted and approved.

d. Funding will be from the Department of the Army, Medical Research and Material Command through an existing Omnibus contract managed by the United States Navy. Please note that all contractual requirements must be addressed prior to initiating the research activity.

3. The following documents were reviewed as part of the approval process:

- Application Form - Part B 20111104 Clean (UPDATED: 11/22/2011)
- Application Form - Part B 20111104 Revised Tracked (UPDATED: 11/22/2011)
- Application Form - *FINAL - Part A 20111103 Clean (UPDATED: 11/22/2011)
- Application Form - Part A 20111103 Revised Tracked (UPDATED: 11/22/2011)
- Application Form - *FINAL - Application Signature page - Corrected (UPDATED: 09/13/2011)
- Application Form - Part B 20110923 (UPDATED: 09/23/2011)
- Application Form - Part A 20110809 (UPDATED: 08/18/2011)
- Confidentiality/Non-Disclosure - *FINAL - Data Disclosure agreement (UPDATED: 08/19/2011)
- Conflict of Interest - Other - *FINAL - COI 20110914 - Corrected (UPDATED: 09/14/2011)
- Consent Form - Control Informed Consent 20111120 Clean (UPDATED: 11/22/2011)
- Consent Form - Control Informed Consent 20111120 Revised Tracked (UPDATED: 11/22/2011)
- Consent Form - Patient Informed Consent 20111120 Clean (UPDATED: 11/22/2011)
- Consent Form - Patient Informed Consent 20111120 Revised Tracked (UPDATED: 11/22/2011)
- Consent Form - Patient Informed Consent (UPDATED: 08/18/2011)
- Consent Form - Control Informed Consent (UPDATED: 08/18/2011)
- Consent Form - Clinician Informed consent (UPDATED: 08/18/2011)
- CV/Resume - *FINAL - Evans CV (UPDATED: 08/19/2011)
- Data Collection - *FINAL - Clinician Interview Questions 20111120 - Appendix I3 (UPDATED: 11/22/2011)
- Data Collection - *FINAL - Patient Interview Questions 20111120 - Appendix I2 (UPDATED: 11/22/2011)
- Data Collection - *FINAL - Medical History - Appendix H 20111120 Revised Clean (UPDATED: 11/22/2011)
- Data Collection - Phone Script 20111120 - Appendix F Clean (UPDATED: 11/22/2011)
- Data Collection - Phone Script 20111120 - Appendix F Revised Tracked (UPDATED: 11/22/2011)
- Data Collection - *FINAL - Completion-Discontinuation - Appendix K (UPDATED: 08/18/2011)
- Data Collection - *FINAL - Subject interaction - Appendix J (UPDATED: 08/19/2011)
- Data Collection - *FINAL - Data Collection Form - Appendix I (UPDATED: 08/18/2011)
- Data Collection - Medical History - Appendix H (UPDATED: 08/18/2011)
- Data Collection - *FINAL - Participant Demographics - Appendix G (UPDATED: 08/19/2011)
- Data Collection - Phone Script - Appendix F (UPDATED: 08/18/2011)
- Data Collection - *FINAL - Patient Inc/Exl Criteria - Appendix E (UPDATED: 08/18/2011)
- Data Collection - *FINAL - Clinicians Inc/Exl Criteria - Appendix D (UPDATED: 08/18/2011)
- Data Collection - *FINAL - Patient Inc/Exl Criteria - Appendix C (UPDATED: 08/18/2011)
- Data Collection - *FINAL - Control Inc/Exl Criteria - Appendix B (UPDATED: 08/18/2011)
- Data Collection - *FINAL - Enrollment Appendix A (UPDATED: 08/18/2011)
- DMRN Research Project Cover Sheet - *FINAL - DMRN Research Project Cover Sheet (UPDATED: 02/8/2012)
- HIPAA Consent/Authorization - HIPPA Authorization 20111120 Clean (UPDATED: 11/22/2011)

- HIPAA Consent/Authorization - HIPPA Authorization 20111120 Revised Tracked (UPDATED: 11/22/2011)
- HIPAA Consent/Authorization - HIPPA Authorization 20110809 (UPDATED: 08/18/2011)
- Letter - *FINAL - Response to IRB Reviewer 20111103 (UPDATED: 11/22/2011)
- Letter - *FINAL - ORNL IRB Memo from Dr Evans (UPDATED: 11/22/2011)
- Other - *FINAL - Impact Statement (UPDATED: 08/22/2011)
- Other - *FINAL - MRMC 2009 Peer Review Panel Summary Statement (UPDATED: 08/19/2011)
- Training/Certification - *FINAL - Evans CITI (UPDATED: 08/19/2011)

4. The U. S. Army Medical Research and Materiel Command (USAMRMC) Human Research Protection Office (HRPO) will complete their second level review and determination of this protocol IAW AR 40-38 on a separate cover.

5. A Research Monitor is not required; protocol is no greater than minimal risk.

6. You are required to report all unanticipated problems involving risks to subjects or others (UPIRSOs) and Serious Adverse Events (SAEs) to the IRB. Any unanticipated adverse events must be reported to the Human Protection Administrator within 24 hours by phone at (210) 916-2598 or (210) 916-0606 or by email at BAMC_IRB_AE@amedd.army.mil.

7. Protocol C.2012.003d will automatically expire on December 7, 2012. If you plan to continue beyond this date, the required continuing review progress report is due to the BAMC IRB no later than six weeks prior to the expiration date. The IRB will attempt to assist you by sending a reminder; however, submission of the continuing review report is your responsibility. Failure to submit the report on time will result in the expiration of your protocol and a requirement to cease all research activities until the entire protocol can be resubmitted.

8. Please be sure to maintain all records in accordance with the terms set forth in your protocol. You are required to have all records, including informed consent and HIPAA documents, available for review by the IRB or other federal agencies.

9. Any changes to your protocol, including any changes in personnel, may not be made without prior IRB approval. Please forward a request for any changes, along with their rationale, to the BAMC IRB for review and approval.

10. Please inform the IRB when the protocol is completed or changes status and forward any significant findings.

11. Please ensure that you remain in compliance with BAMC Memo 70-1. Review and approval of abstract and/or manuscript submissions should be made through the Department of Clinical Investigation prior to any release. Contact Ms. Ileana King-Letzkus at 916-2000 for additional details.

12. If at any time you have questions regarding your responsibilities as a Principal Investigator, please contact Lt. Col. David M. Bush at 210-916-1005 or david.m.bush1@us.army.mil. On behalf of the entire IRB, we wish you much success with your research protocol. We look forward to reviewing the progress of your study in the coming months.

This document has been electronically signed in accordance with all applicable regulations, and a copy is retained within our records.

Partnerships for Innovation



Oak Ridge Site-wide Institutional Review Board (ORSIRB)
Telephone (865) 576-1725
Becky.Hawkins@orise.orau.gov

MEMORANDUM

DATE: June 8, 2012

TO: Boyd Evans, PhD

FROM: Oak Ridge Site-Wide IRB (FWA #00005031)

STUDY TITLE: [339076-1] Development of a Mobile Gait Analysis System for Lower-Limb Amputee High-Level Activity Rehabilitation

IRB REFERENCE #: ORNL(12)-127

SUBMISSION TYPE: New Project

ACTION: APPROVED

APPROVAL DATE: 6/21/12

EXPIRATION DATE: 6/20/13

REVIEW TYPE: Expedited Review

Thank you for your submission of New Project materials for this research study. The Oak Ridge Site-Wide IRB has APPROVED your submission. This approval is based on an appropriate risk/benefit ratio and a study design wherein the risks have been minimized. All research must be conducted in accordance with this approved submission.

This study has received Expedited Review based on the applicable federal regulation as outlined in 45 CFR 46.110(b)(1). Regulations under FDA 21 CFR 50 and 46 were also consulted, as appropriate. For investigational devices, non-significant risk (NSR) device studies must follow abbreviated IDE requirements (21 CFR 812.2) and do not have to have an IDE application approved by the FDA. This includes following regulations outlined in 812.5 for labeling of investigational devices that state "An investigational device or its immediate package shall bear a label with the following information: the name and place of business of the manufacturer, packer, or distributor, the quantity of contents, if appropriate, and the following statement: "CAUTION - Investigational device. Limited by Federal law to investigational use. The label or other labeling shall describe all relevant contraindications, hazards, adverse effects, interfering substances or devices, warnings, and precautions."

Please note that any revision to previously approved materials must be approved by this office prior to initiation. Please use the appropriate revision forms for this procedure.

All SERIOUS and UNEXPECTED adverse events must be reported to this office. Please use the appropriate adverse event forms for this procedure. All FDA and sponsor reporting requirements should also be followed.

Please report all NON-COMPLIANCE issues or COMPLAINTS regarding this study to this office.

Please note that all research records must be retained for a minimum of three years.

Based on the risks, this project requires Continuing Review by this office on an annual basis. Please use the appropriate renewal forms for this procedure. The required continuing review progress report is due to the ORSIRB no later than 3 weeks prior to the expiration date. IRBNet and the ORSIRB will attempt to assist you by sending a reminder; however, submission of the continuing review report is your responsibility. Failure to submit the report on time will result in the expiration of your protocol and a requirement to cease all research activities until the entire protocol can be resubmitted.

Please inform the IRB when the protocol is completed using the Closure Report Form in IRBNet.

If you have any questions, please contact Becky Hawkins at 865-576-1725 or becky.hawkins@orise.orau.gov or Leigh Greeley at 865-576-1367 or greeleylg@ornl.gov. Please include your study title and reference number in all correspondence with this office.

Partnerships for Innovation



Oak Ridge Site-wide Institutional Review Board (ORSIRB)

Telephone (865) 576-1725

Becky.Hawkins@orise.orau.gov

DATE: August 6, 2012

TO: Martin Pusch, Dipl. Ing.

FROM: Oak Ridge Site-Wide IRB (FWA #00005031)

STUDY TITLE: [364253-1] Development of a Mobile Gait Analysis System for Lower-Limb Amputee High-Level Activity Rehabilitation

IRB REFERENCE #: OTTOBOCK(12)-1

SUBMISSION TYPE: New Project

ACTION: APPROVED

APPROVAL DATE: August 6, 2012

EXPIRATION DATE:

REVIEW TYPE: Expedited Review

Thank you for your submission of New Project materials for this research study. The Oak Ridge Site-Wide IRB has APPROVED your submission. This approval is based on an appropriate risk/benefit ratio and a study design wherein the risks have been minimized. All research must be conducted in accordance with this approved submission.

This study has received Expedited Review based on the applicable federal regulation as outlined in 45 CFR 46.110(b)(1). Regulations under FDA 21 CFR 50 and 46 were also consulted, as appropriate. For investigational devices, non-significant risk (NSR) device studies must follow abbreviated IDE requirements (21 CFR 812.2) and do not have to have an IDE application approved by the FDA. This includes following regulations outlined in 812.5 for labeling of investigational devices that state "An investigational device or its immediate package shall bear a label with the following information: the name and place of business of the manufacturer, packer, or distributor, the quantity of contents, if appropriate, and the following statement: "CAUTION - Investigational device. Limited by Federal law to investigational use. The label or other labeling shall describe all relevant contraindications, hazards, adverse effects, interfering substances or devices, warnings, and precautions."

Please note that any revision to previously approved materials must be approved by this office prior to initiation. Please use the appropriate revision forms for this procedure.

All SERIOUS and UNEXPECTED adverse events must be reported to this office. Please use the appropriate adverse event forms for this procedure. All FDA and sponsor reporting requirements should also be followed.

Please report all NON-COMPLIANCE issues or COMPLAINTS regarding this study to this office.

Please note that all research records must be retained for a minimum of three years.

Based on the risks, this project requires Continuing Review by this office on an annual basis. Please use the appropriate renewal forms for this procedure. The required continuing review progress report is due to the ORSIRB no later than 3 weeks prior to the expiration date. IRBNet and the ORSIRB will attempt to assist you by sending a reminder; however, submission of the continuing review report is your responsibility. Failure to submit the report on time will result in the expiration of your protocol and a requirement to cease all research activities until the entire protocol can be resubmitted.

If you have any questions, please contact Lindsay Motz at (865) 576-4359 or lindsay.motz@orise.orau.gov or Leigh Greeley at 865-576-1367 or greeleylg@ornl.gov. Please include your study title and reference number in all correspondence with this office.