

REPORT DOCUMENTATION PAGE

Form Approved
OMB No. 0704-0188

Public reporting burden for this collection of information is estimated to average 1 hour per response, including the time for reviewing instructions, searching existing data sources, gathering and maintaining the data needed, and completing and reviewing this collection of information. Send comments regarding this burden estimate or any other aspect of this collection of information, including suggestions for reducing this burden to Department of Defense, Washington Headquarters Services, Directorate for Information Operations and Reports (0704-0188), 1215 Jefferson Davis Highway, Suite 1204, Arlington, VA 22202-4302. Respondents should be aware that notwithstanding any other provision of law, no person shall be subject to any penalty for failing to comply with a collection of information if it does not display a currently valid OMB control number. **PLEASE DO NOT RETURN YOUR FORM TO THE ABOVE ADDRESS.**

1. REPORT DATE (DD-MM-YYYY) 22-06-2012		2. REPORT TYPE Briefing Charts		3. DATES COVERED (From - To)	
4. TITLE AND SUBTITLE Trajectory and Mixing Scaling Laws for Confined and Unconfined Transverse Jets				5a. CONTRACT NUMBER	
				5b. GRANT NUMBER	
				5c. PROGRAM ELEMENT NUMBER	
6. AUTHOR(S) D. Forliti				5d. PROJECT NUMBER	
				5f. WORK UNIT NUMBER 33SP0795	
7. PERFORMING ORGANIZATION NAME(S) AND ADDRESS(ES) Air Force Research Laboratory (AFMC) AFRL/RQRE 4 Draco Drive Edwards AFB CA 93524-7160				8. PERFORMING ORGANIZATION REPORT NUMBER	
9. SPONSORING / MONITORING AGENCY NAME(S) AND ADDRESS(ES) Air Force Research Laboratory (AFMC) AFRL/RQR 5 Pollux Drive Edwards AFB CA 93524-7048				10. SPONSOR/MONITOR'S ACRONYM(S)	
				11. SPONSOR/MONITOR'S NUMBER(S) AFRL-RZ-ED-VG-2012-222	
12. DISTRIBUTION / AVAILABILITY STATEMENT Distribution A: Approved for public release; distribution unlimited. PA# 12488.					
13. SUPPLEMENTARY NOTES To be presented at the AIAA Fluids conference, New Orleans, LA, 25-28 June 2012.					
14. ABSTRACT Transverse jets play an important role in many propulsion-related applications including gas turbine burner dilution, exhaust from V/STOL aircraft, and fluidic thrust vectoring. Although this flow has received extensive research attention over several decades, a lack of universality exists regarding scaling laws available in literature. Using data from existing literature, a foundational scaling law framework has been proposed for the jet trajectory and mixture uniformity. A newly derived parameter demonstrates an improved collapse of trajectory data in literature. This parameter was derived using theoretical arguments that both entrainment and aerodynamic drag should be considered as relevant mechanisms of momentum transport between the jet and cross flow. An experimental study was conducted and the results indicate the utility of the new scaling law parameter for defining flow regimes and correlating mixing performance. Future work will extend this scaling law framework for multiple transverse jet configurations.					
15. SUBJECT TERMS					
16. SECURITY CLASSIFICATION OF:			17. LIMITATION OF ABSTRACT	18. NUMBER OF PAGES	19a. NAME OF RESPONSIBLE PERSON
a. REPORT	b. ABSTRACT	c. THIS PAGE			Nils Sedano
Unclassified	Unclassified	Unclassified	SAR	24	19b. TELEPHONE NUMBER (include area code) N/A



Trajectory and Mixing Scaling Laws for Confined and Unconfined Transverse Jets

AIAA Fluid Dynamics Meeting
June 25-28, 2012
New Orleans, LA

David Forliti, Ph.D.

Jackson and Tull

Air Force Research Lab

Edwards Air Force Base



Distribution A: Approved for public release; distribution unlimited.



Outline



- **Objectives**
- **Background on scaling laws**
 - Unconfined transverse jet trajectories
 - Confined transverse jet mixing
- **New scaling law variable**
- **Experimental facility**
- **Mixing results**
- **Conclusions and future work**



Objectives



- **Transverse jets present in environment and engineering**
 - Smoke stacks
 - Thrust vectoring
 - Combustion chamber mixing
 - Flow reactors

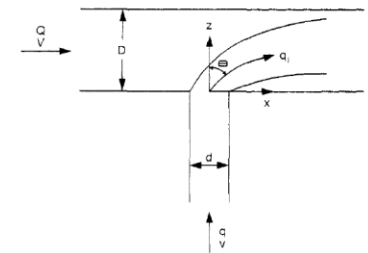
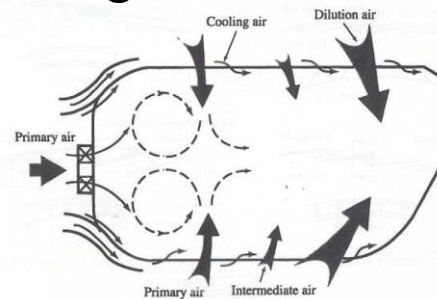

Lack of universal scaling laws and parameters that span wide domains of the operating space



Scaling Laws

- Jet trajectories**

$$r = \frac{U_j}{U_o}$$

$$J = \frac{\rho_j U_j^2}{\rho_o U_o^2}$$

Keffer and Baines (1963) $\rightarrow \frac{y - y_o}{r^2 D} = f\left(\frac{x - x_o}{r^2 D}\right)$

Kamotani and Greber (1972) $\rightarrow \frac{y}{D} = 0.89 J^{0.47} \left(\frac{x}{D}\right)$

Hasselbrink and Mungal (2001) $\rightarrow \frac{y}{rD} = f\left(\frac{x}{rD}\right)$

- Mixing optimization**

One jet:
Maruyama et al. (1983) $r = 1.49 \left(\frac{D_j}{D_o}\right)^{-0.415}$

8-20 jets:
Holdeman (1993)

$$\frac{S}{H} J^{1/2} = 2.5 \rightarrow J = 1.27 \frac{n^2}{D_o^2}$$

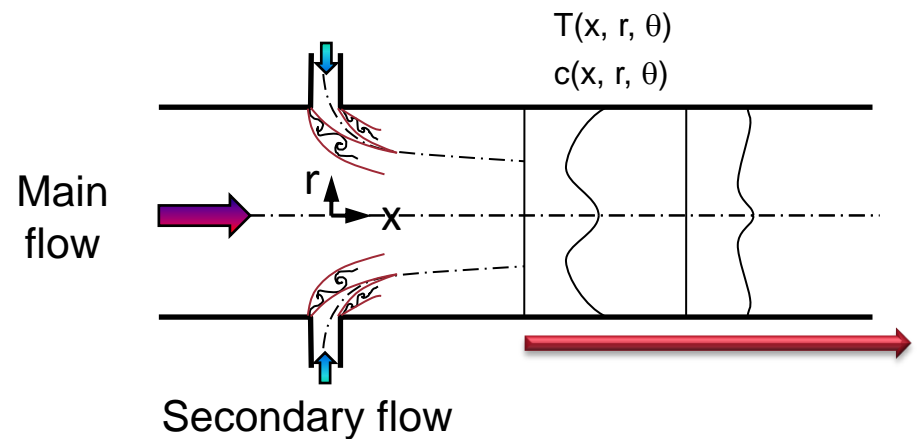
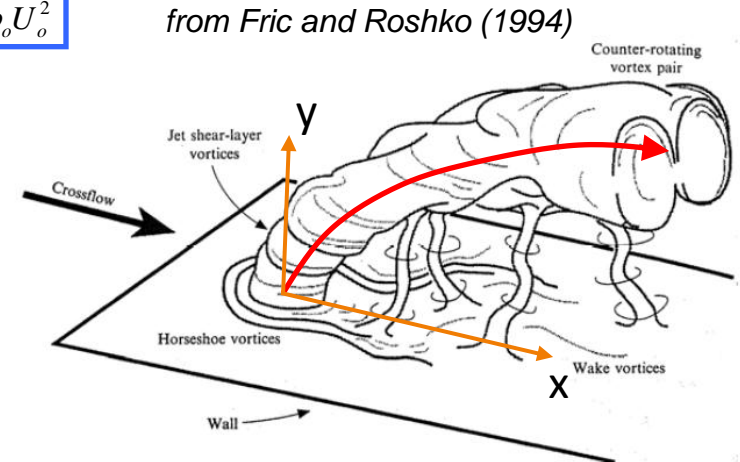



Trajectory Scaling

- Traditional rd and r^2d scaling laws

“entrainment mechanism”

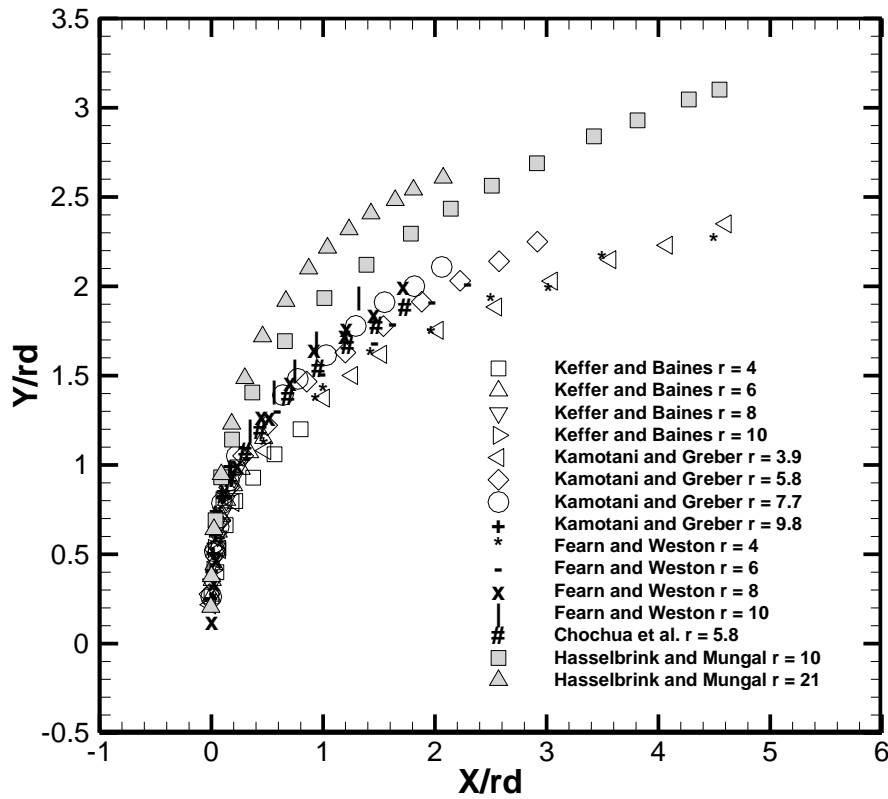

“drag mechanism”

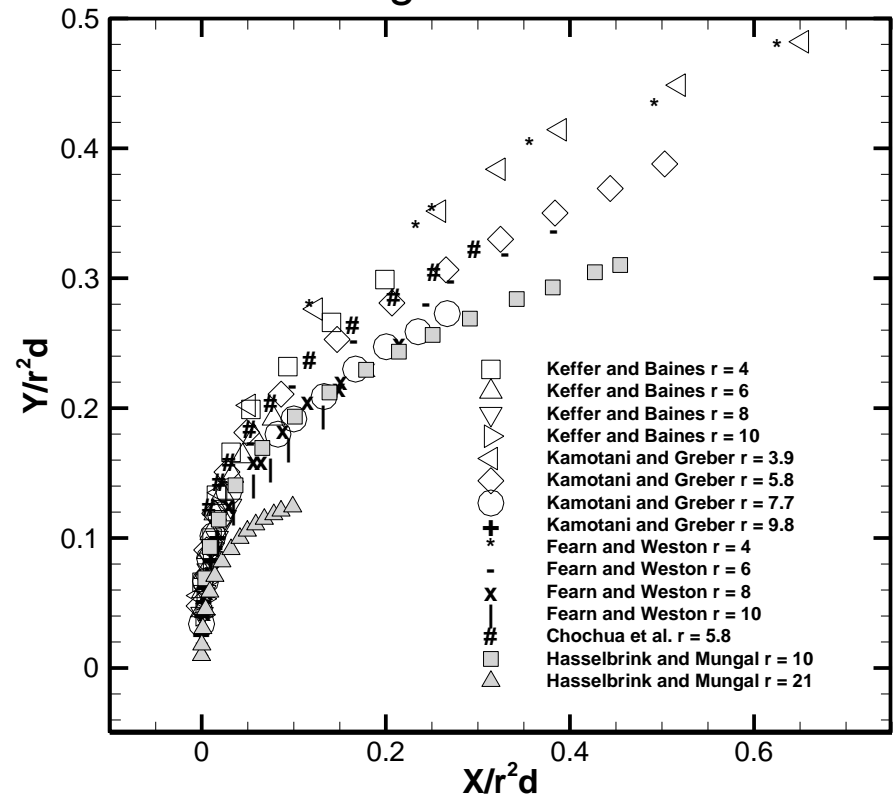



Momentum Transport to the Jet



- Entrainment**

$$\frac{\dot{m}(x)}{\dot{m}_{jet}} = C_{ej} \left(\frac{\rho_{jet}}{\rho_{\infty}} \right)^{-1/2} \left(\frac{x}{d} \right)$$

Ricou and Spalding (1961)

Cross flow fluid mass entrained over a streamwise distance of 1 jet diameter



$$\dot{m}_{entrained} = \dot{m}_{jet} C_{ej} \frac{1}{S^{1/2}}$$

$$\dot{m}_{jet} = \pi \frac{d^2}{4} \rho_j U_j$$

Rate of momentum addition to the jet in the cross flow direction



$$\dot{m}_{entrained} U_o = \dot{m}_{jet} C_{ej} \frac{1}{S^{1/2}} U_o$$

Ratio of new to original momentum rates



$$\frac{\dot{m}_{entrained} U_o}{\dot{m}_{jet} U_j} = \frac{\dot{m}_{jet} C_{ej} \frac{1}{S^{1/2}} U_o}{\dot{m}_{jet} U_j} = \frac{C_{ej}}{J^{1/2}}$$



Momentum Transport to the Jet



- **Drag**

Consider a 1 diameter length element of the jet near the injection location:

Rate of momentum
transport to the jet due
pressure = drag force



$$F = \frac{1}{2} \rho_o U_o^2 A C_d$$

Considering a streamwise
distance of 1 jet diameter



$$A = d^2$$

Rate of transport of momentum
from the jet orifice



$$\dot{m}_{jet} U_j = \pi \frac{d^2}{4} \rho_j U_j^2$$

Ratio of new to
original momentum
rates



$$\frac{F}{\dot{m}_{jet} U_j} = \frac{\frac{1}{2} \rho_o U_o^2 d^2 C_d}{\frac{\pi}{4} d^2 \rho_j U_j^2} = \frac{2 C_d}{\pi J}$$



Momentum Transport to the Jet



- **Momentum and drag**

Combine the total momentum transport ratios:

Ratio of total new to original jet momentum



$$\frac{C_{ej}}{J^{1/2}} + \frac{2C_d}{\pi J}$$

Invert this ratio and define as a new parameter B:

$$B = \frac{J}{\frac{2C_d}{\pi} + 0.32J^{1/2}}$$

Bd represents the streamwise distance at which the magnitude of the total new momentum is equal to the jet momentum. The trajectory should scale with Bd, within the limitations of the assumptions of the analysis.



Trajectory Scaling

- New scaling parameter– entrainment and drag

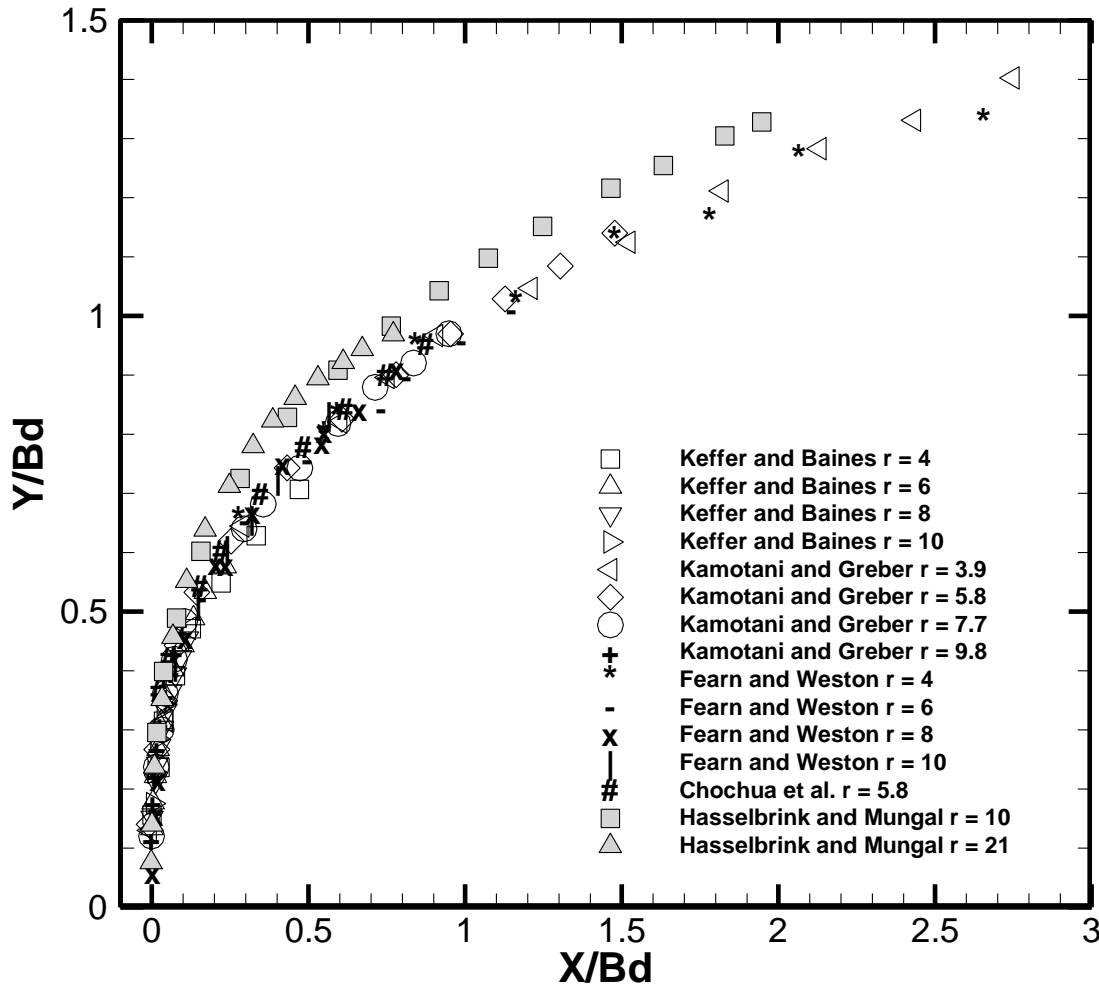

$$B = \frac{J}{\frac{2C_d}{\pi} + 0.32J^{1/2}}$$

$$C_d \cong 1.7$$

Mashayek,
Jafari, and
Ashgriz (2008)



Optimum Mixing: Single Jet



Single jet optimum mixing correlations

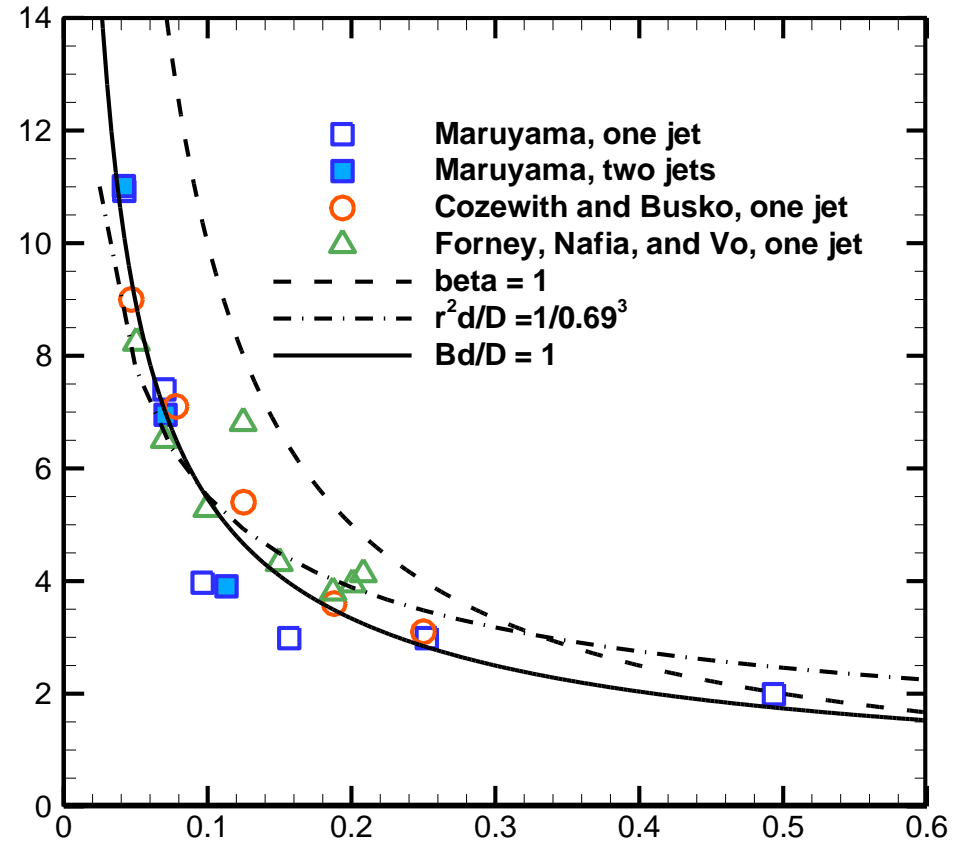
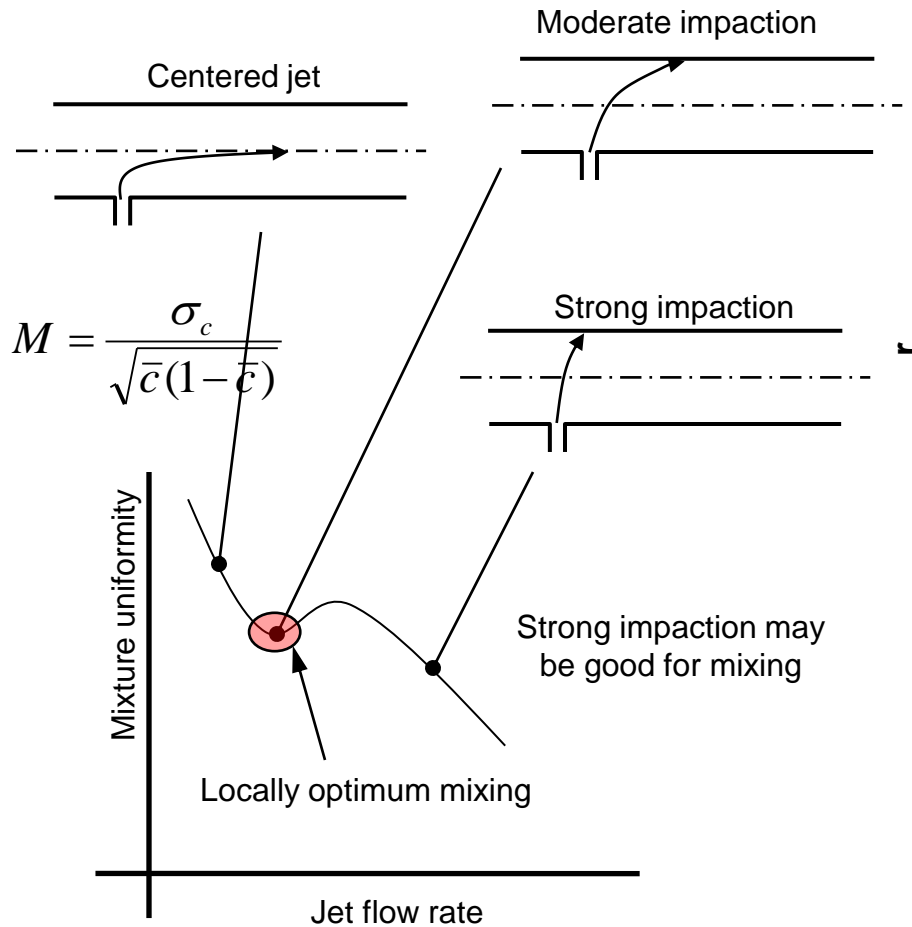



Multiple Jet Optimum Mixing



NASA trade study: 8-20 jets

$$C_{opt} = \frac{S}{R_o} \sqrt{J} = 2.5$$

- **No jet diameter dependence**
- Mass flow ratios 0.5 to 2.5
- Purely empirical (i.e. no physical basis)

Planar example:

Temperature distributions from RANS modelling, Morris, Snyman, Meyer, J. Power and Propulsion, 2007.

Bain, Smith, Holdeman (1995):
Jets should penetrate 1/4 of channel height

$$C = \frac{S}{R_o} \sqrt{J} > 5 \text{ Overpenetration}$$

$$C_{opt} = \frac{S}{R_o} \sqrt{J} = 2.5 \text{ Optimum mixing}$$

$$C = \frac{S}{R_o} \sqrt{J} < 1.25 \text{ Underpenetration}$$

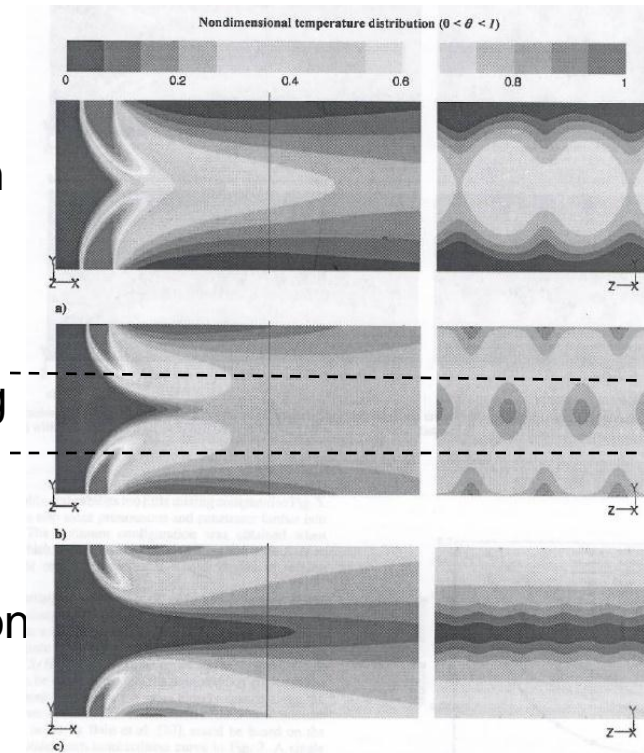



Optimum Mixing Scaling Law

$$B = \frac{J}{\frac{2C_d}{\pi} + 0.32J^{1/2}}$$

$$\frac{BD_j}{D_o} = 1$$

$$\frac{D_j}{D_o} = 0.05$$

$$\frac{D_j}{D_o} = 0.1$$

$$\frac{D_j}{D_o} = 0.2$$

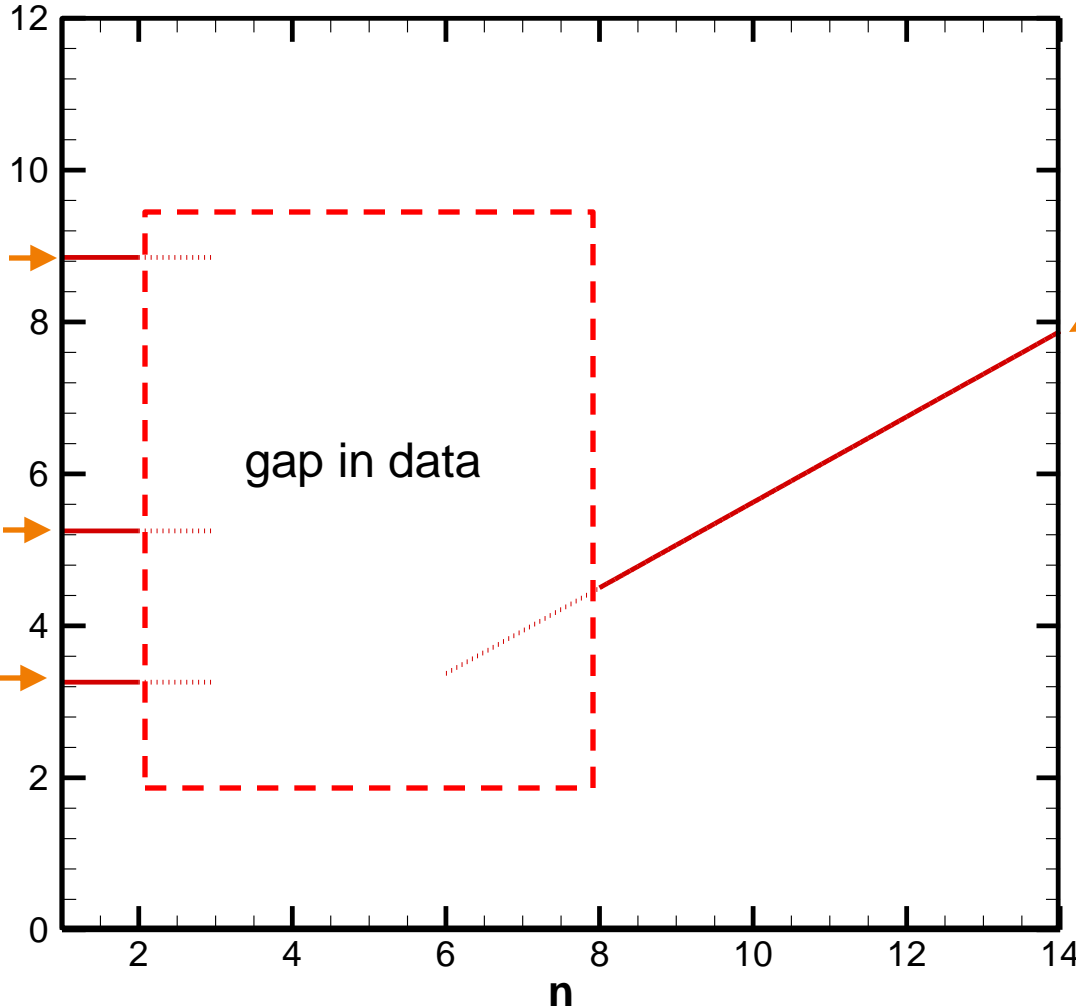

Holdeman scaling

$$n_{opt} = \frac{\pi\sqrt{2}}{2.5} r$$

valid at $x/D_o > 3??$



Limitations on Entrainment

- Single jet (Tee mixer)

$$\dot{m}_{entrained} = \dot{m}_o$$

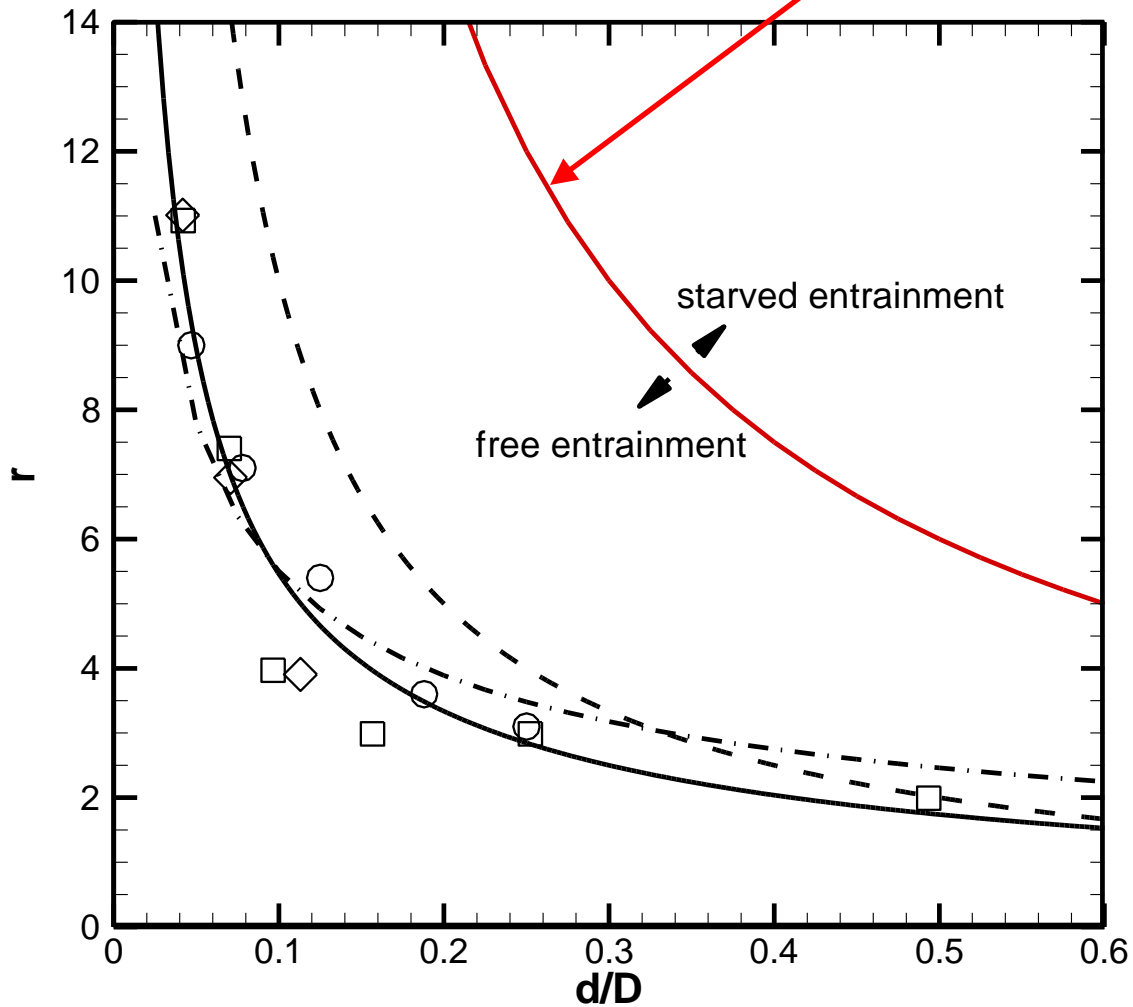



Limitations on Entrainment



- Multiple jets

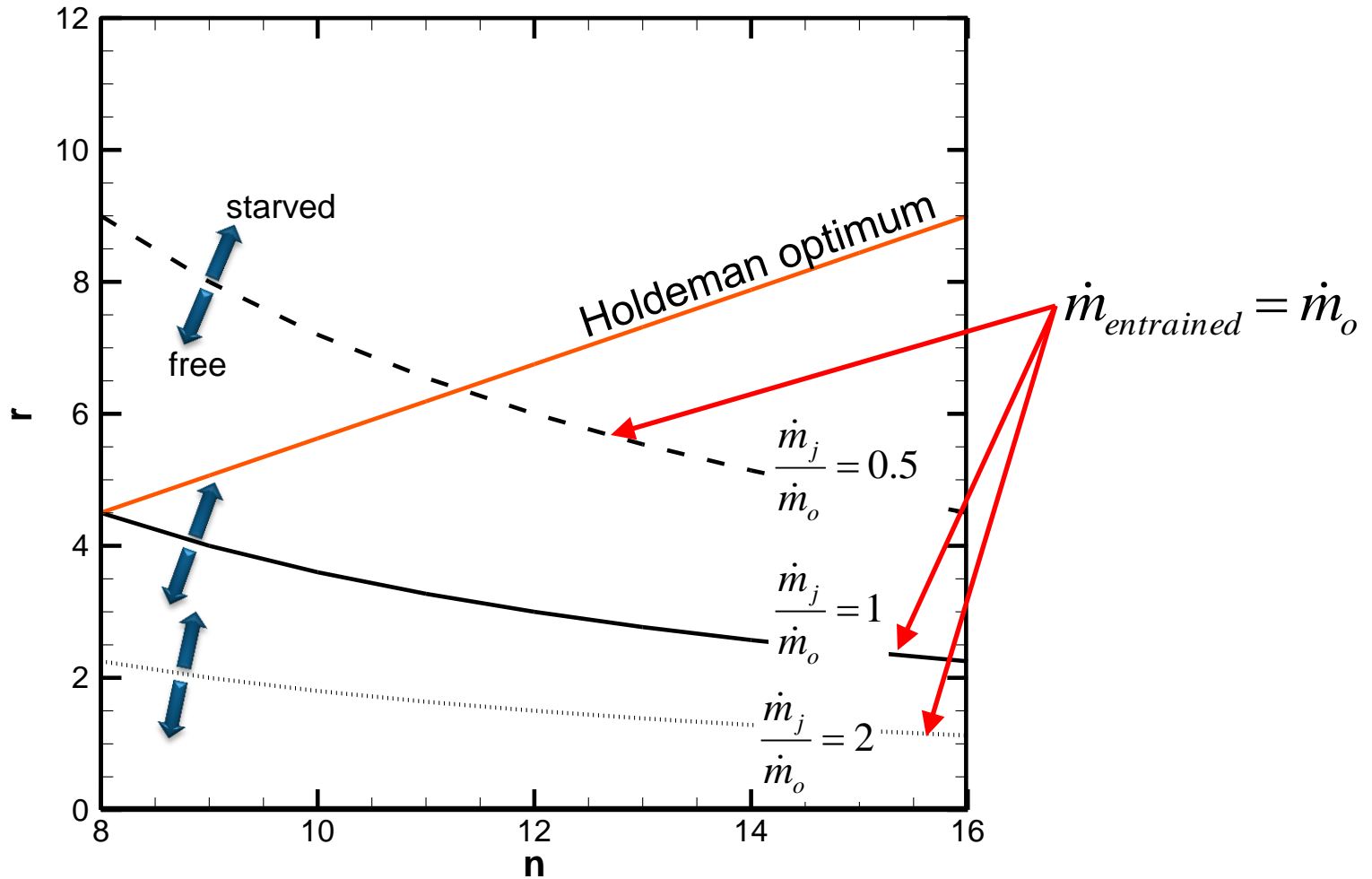



AFRL Water Experiments



Scalar field measurements using planar laser induced fluorescence (PLIF)

Maruyama (1983)

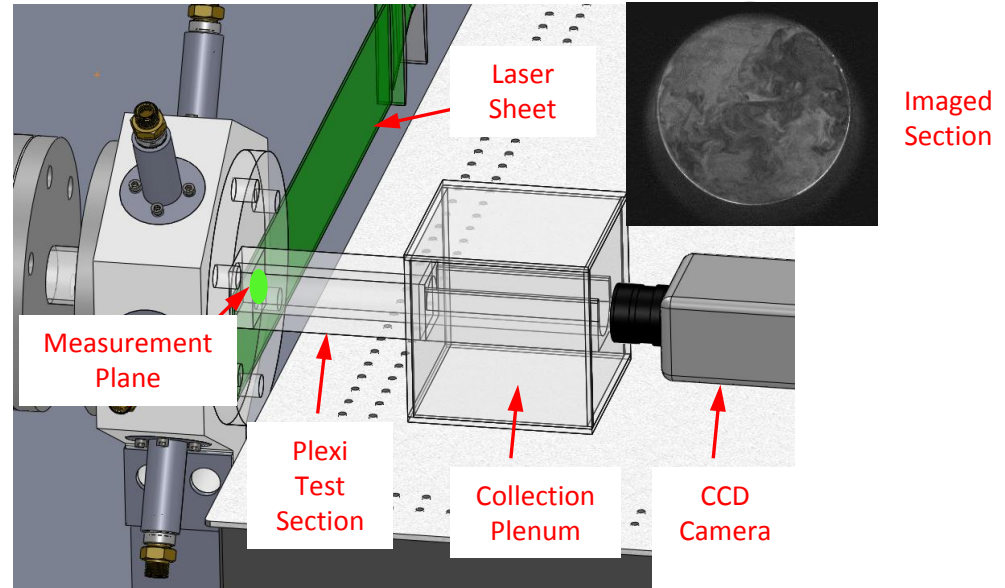
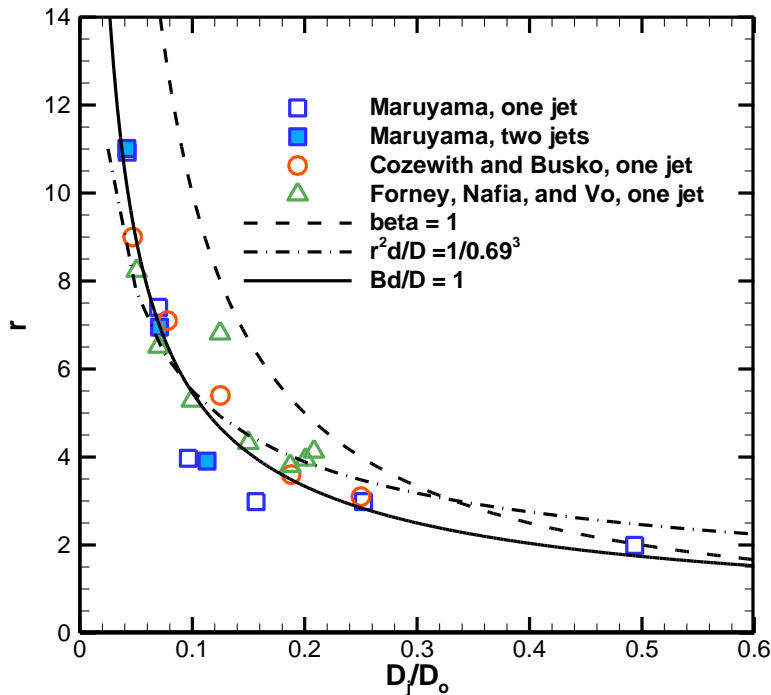

Holdeman optimum mixing (8-20 jets)

$$C = \frac{S}{R_o} \sqrt{J} = 2.5$$

$$n_{opt} = \frac{\pi \sqrt{2}}{2.5} r$$

3-6 jets
 Transition between regimes



Water Experiment



- Experimental conditions
- $Re_j > 6000$
- $Re_o > 6000$
- $1.3 < r < 7$
- $1.8 < J < 50$
- $D_j/D_o = 0.12, 0.165, 0.21$
- $x/D_o = 3.0$
- $0.25 < BD_j/D_o < 1.75$
- Turbine and rotameter flow meters

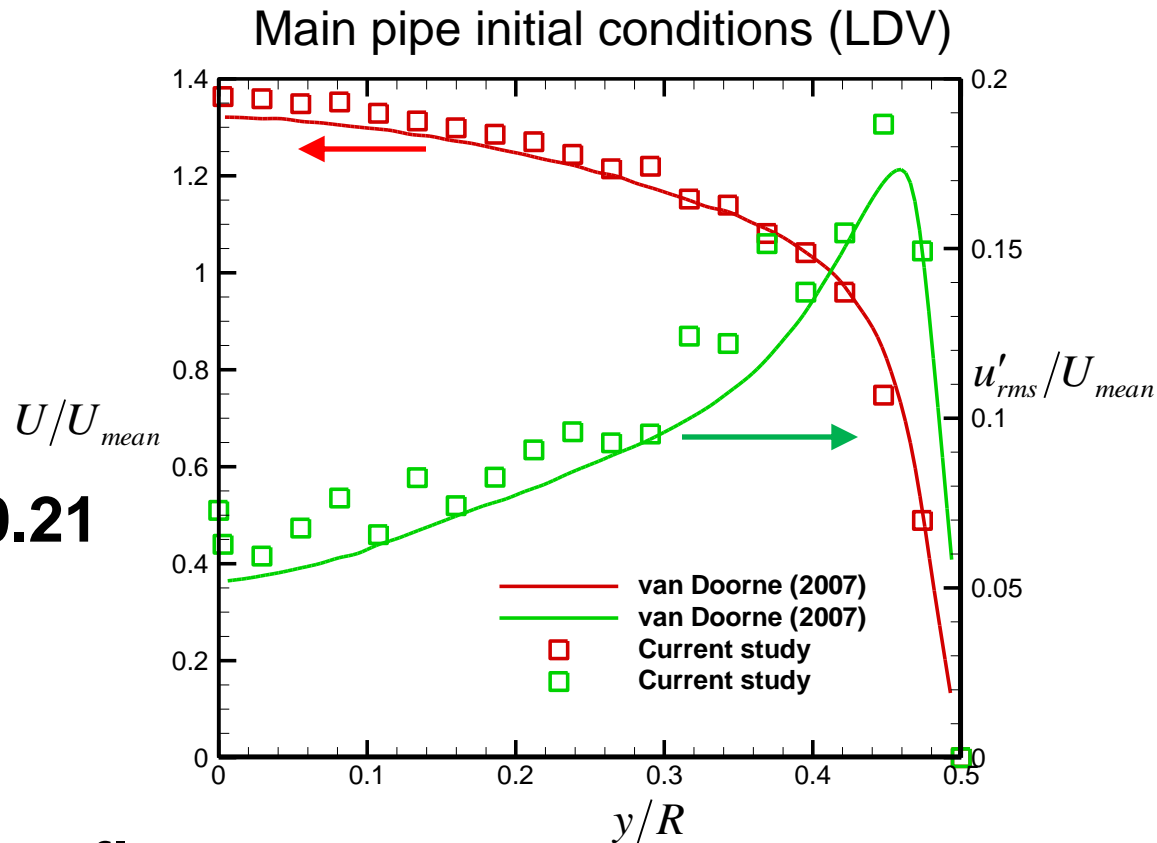



Fluorescence

Sodium fluorescein

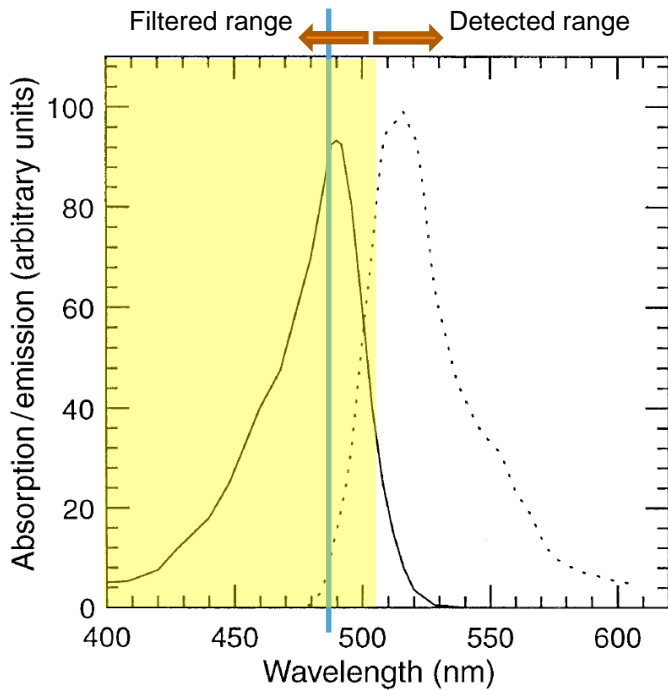

From Karasso and Mungal (1997)

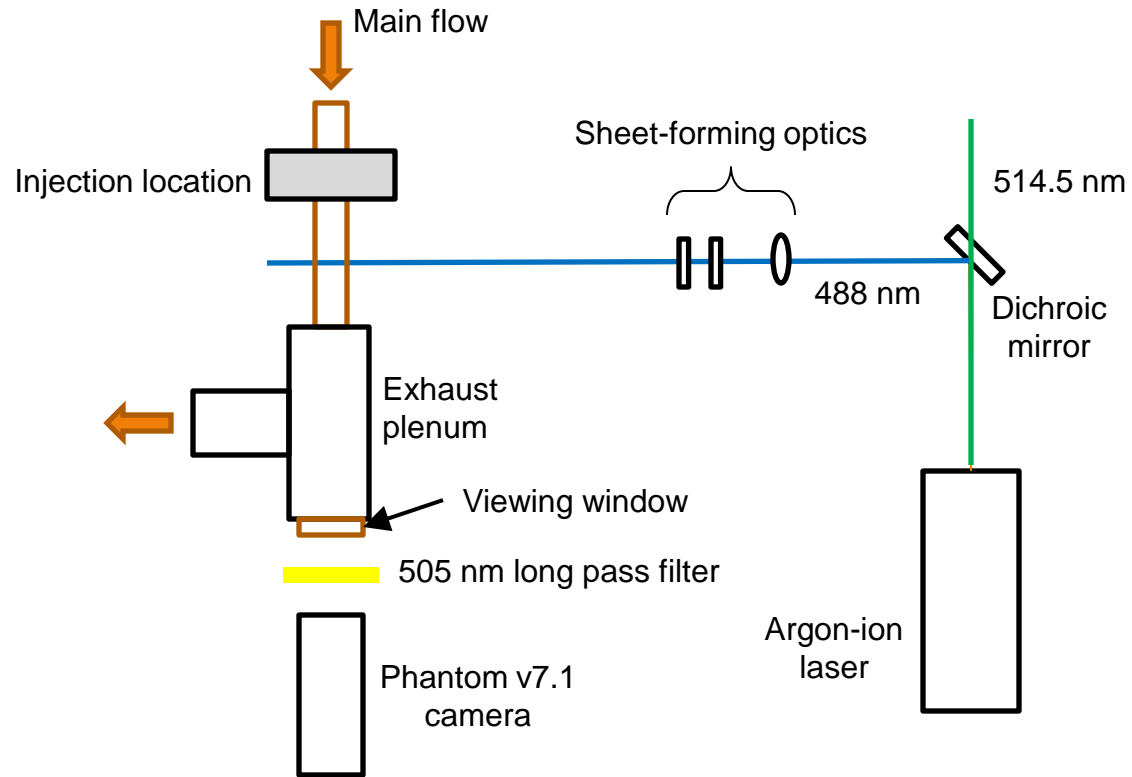

Use calibration pictures with known homogenous mixtures

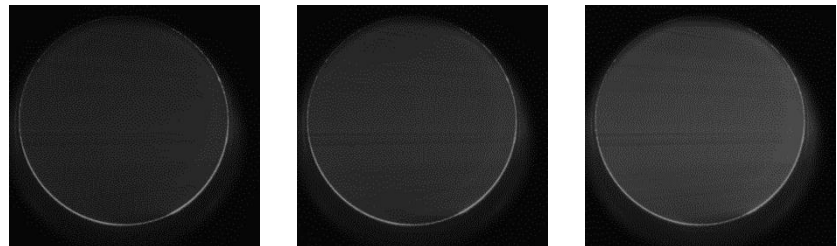



PLIF Images



- **Single Jet PLIF samples**

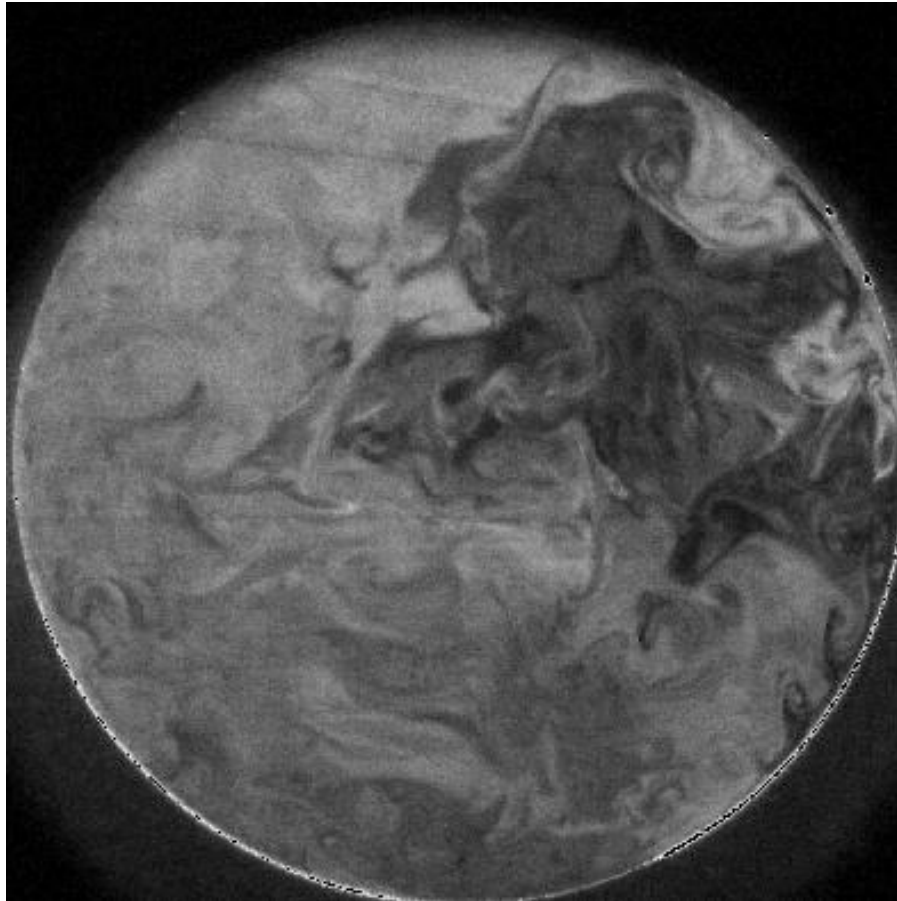

Instantaneous

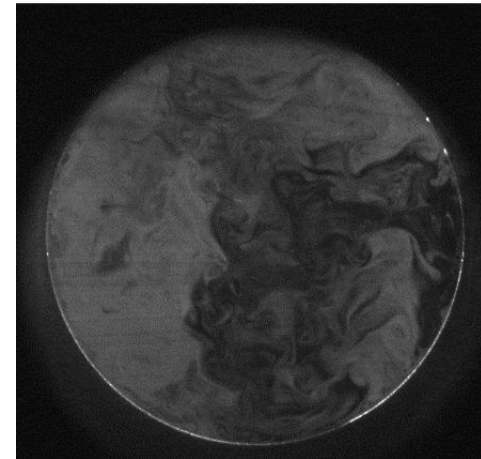

1.67 second average

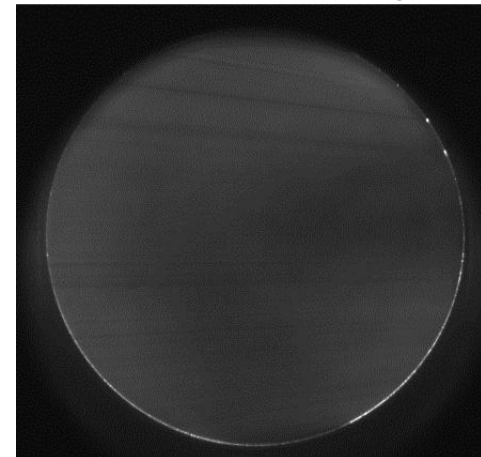



Mean Mixture Fraction Distributions

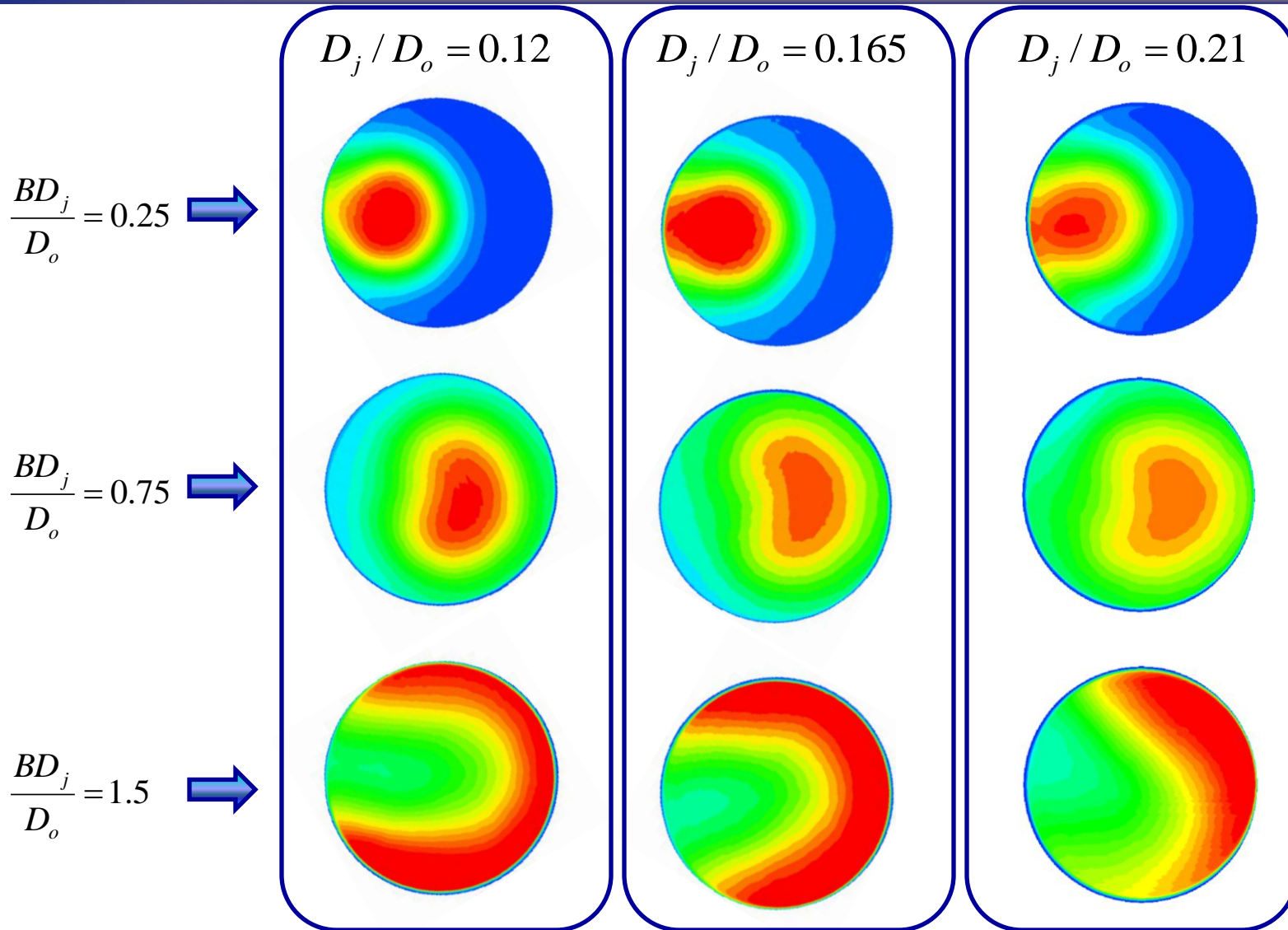



Unmixedness

- Single Jet

$$U_z = \frac{\sigma_c}{\sqrt{\bar{c}(1-\bar{c})}}$$

D_j/D_o	J_{opt}
0.12	14.1
0.165	9
0.21	6.9

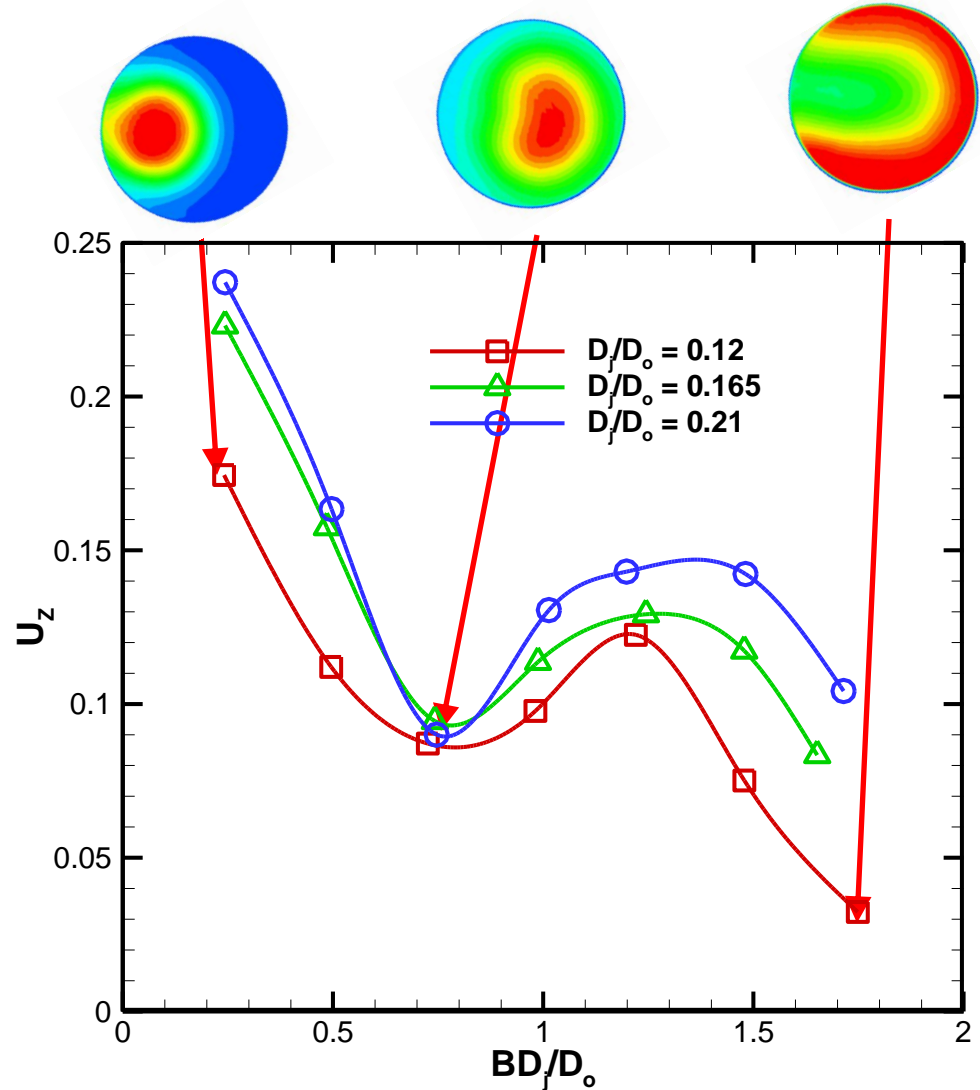



Optimum Mixing Scaling Law

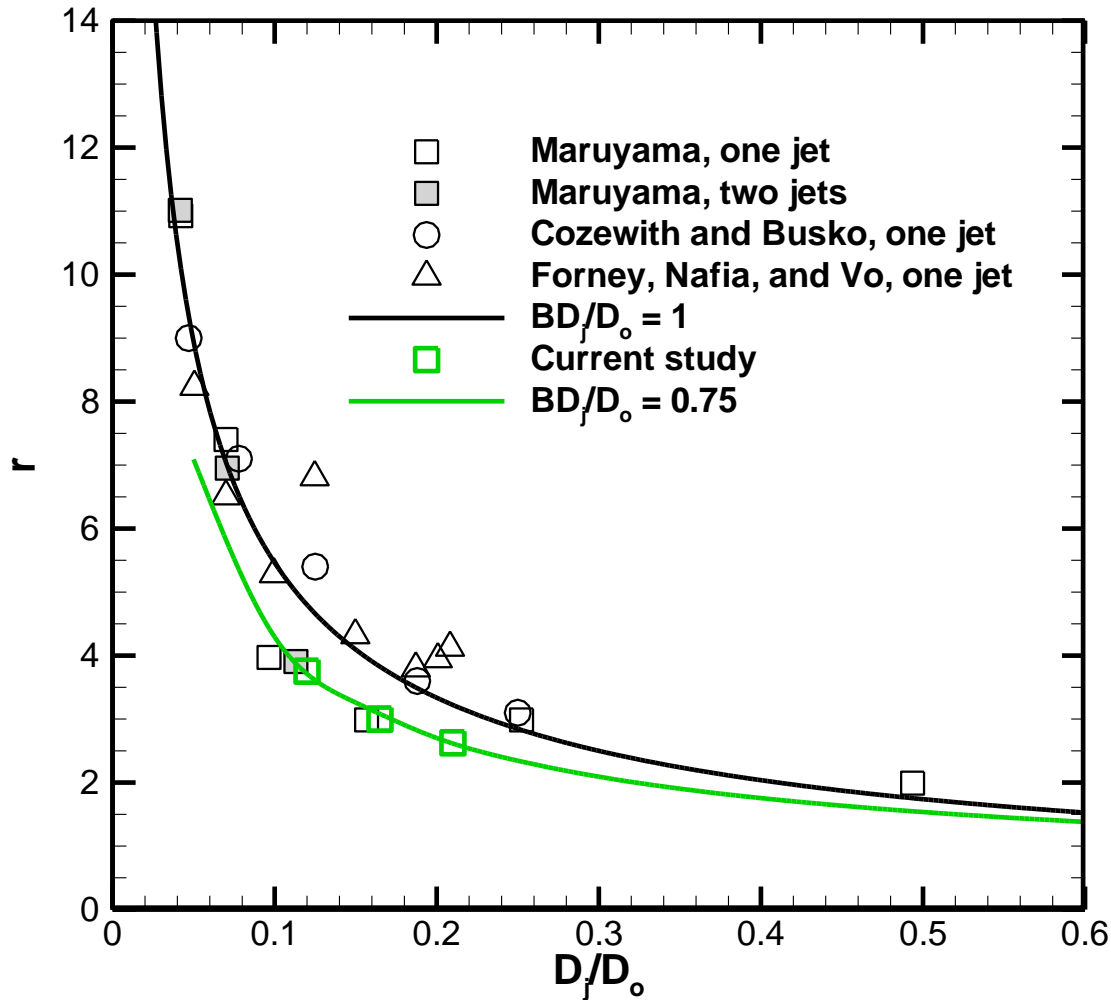



Conclusions



- **Definition of a new scaling law for jet trajectory**
 - Entrainment and drag mechanisms
 - Improved universality for unconfined single transverse jets
 - $BD_j/D_o=C$ predictive for optimum mixing scaling law for Tee mixer
- **New experimental data on single confined transverse jets**
 - BD_j/D_o value indicates flow regime for different size jets
 - Local optimum point at $BD_j/D_o \sim 0.75$



Backup slides





Optimum Mixing Scaling Law

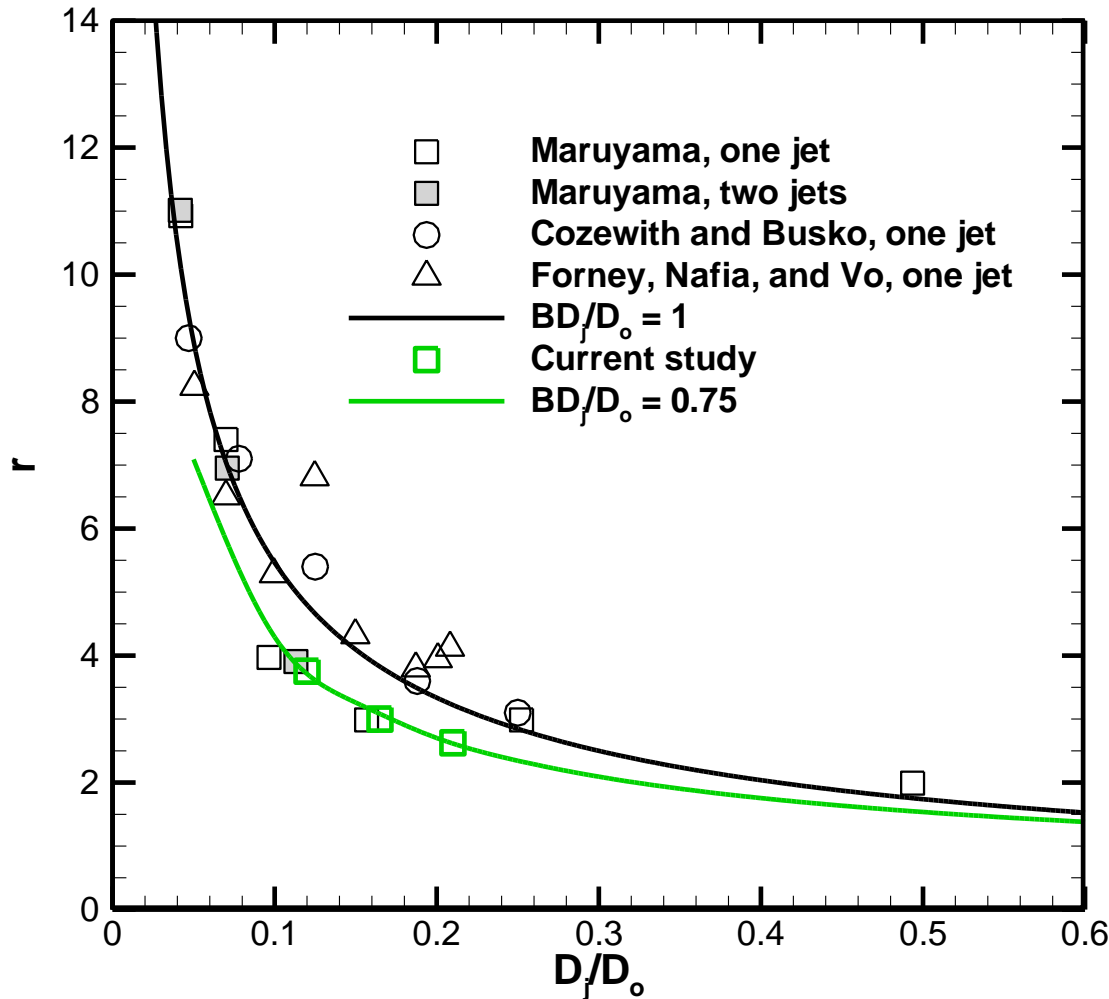

Possible sources of discrepancy:

- Cozewith data based on chemical reaction—microscale mixing
- Forney data based on RANS
- Current data limited to only $x/D = 3.0$