

High Frequency Acoustical Propagation and Scattering in Coastal Waters

David M. Farmer
Graduate School of Oceanography (educational)
University of Rhode Island
Narragansett, RI 02882
Phone: (401) 874-6222 fax (401) 874-6889 email: dfarmer@gso.uri.edu

Svein Vagle
Institute of Ocean Sciences
Fisheries and Oceans Canada (foreign government)
PO Box 6000, Sidney, B.C., Canada V8L 4B2
phone: (250) 363-6339 fax: (250) 363-6798 email: vagles@pac.dfo-mpo.gc.ca

Award Number: N000140210682

LONG-TERM GOALS

To study the physical processes controlling the propagation of high frequency acoustical signals. Of particular interest is the relationship between bubble distributions, surface gravity waves and turbulence and their effects on sound propagation.

A second long-term goal is to model these processes to improve our understanding and to enhance the predictive capabilities.

OBJECTIVES

Our objectives are (1) to develop new techniques and approaches for high frequency acoustical propagation experiments in environments with dense bubble distributions and significant turbulence; (2) to carry out such experiments; (3) to model sound propagation in these environments; and (4) to interpret the results in terms of appropriate acoustic models.

APPROACH

Our approach to studies of high frequency propagation in bubbly water near the ocean surface includes observational and model analysis of forward and back-scattered sound as well as analysis of the naturally occurring ambient noise field.

A preliminary attempt to acquire data during the Martha's Vineyard Coastal Observatory experiment (SPACE02) was foiled by a failed mooring and loss of instruments. A revised experiment will be carried out in Narragansett Bay using rebuilt equipment. The new instrumentation includes high-frequency (100kHz) acoustical backscatter in both vertical and slant mode operation investigate dense bubble clouds in the surf zone and their link to wave and bottom induced turbulence. In addition the acoustic system is being set up on a bistatic array so as to permit transmission of communication signals at the same time as surface and volume back scatter measurements are being acquired. Instrumentation will be deployed and tested in November 2005.

Report Documentation Page

*Form Approved
OMB No. 0704-0188*

Public reporting burden for the collection of information is estimated to average 1 hour per response, including the time for reviewing instructions, searching existing data sources, gathering and maintaining the data needed, and completing and reviewing the collection of information. Send comments regarding this burden estimate or any other aspect of this collection of information, including suggestions for reducing this burden, to Washington Headquarters Services, Directorate for Information Operations and Reports, 1215 Jefferson Davis Highway, Suite 1204, Arlington VA 22202-4302. Respondents should be aware that notwithstanding any other provision of law, no person shall be subject to a penalty for failing to comply with a collection of information if it does not display a currently valid OMB control number.

| | | | | | |
|---|------------------------------------|---|---|---------------------------------|---------------------------------|
| 1. REPORT DATE 30 SEP 2005 | 2. REPORT TYPE | 3. DATES COVERED 00-00-2005 to 00-00-2005 | | | |
| 4. TITLE AND SUBTITLE High Frequency Acoustical Propagation and Scattering in Coastal Waters | | 5a. CONTRACT NUMBER | | | |
| | | 5b. GRANT NUMBER | | | |
| | | 5c. PROGRAM ELEMENT NUMBER | | | |
| 6. AUTHOR(S) | | 5d. PROJECT NUMBER | | | |
| | | 5e. TASK NUMBER | | | |
| | | 5f. WORK UNIT NUMBER | | | |
| 7. PERFORMING ORGANIZATION NAME(S) AND ADDRESS(ES) University of Rhode Island, Graduate School of Oceanography (educational), Narragansett, RI, 02882 | | 8. PERFORMING ORGANIZATION REPORT NUMBER | | | |
| 9. SPONSORING/MONITORING AGENCY NAME(S) AND ADDRESS(ES) | | 10. SPONSOR/MONITOR'S ACRONYM(S) | | | |
| | | 11. SPONSOR/MONITOR'S REPORT NUMBER(S) | | | |
| 12. DISTRIBUTION/AVAILABILITY STATEMENT Approved for public release; distribution unlimited | | | | | |
| 13. SUPPLEMENTARY NOTES code 1 only | | | | | |
| 14. ABSTRACT To study the physical processes controlling the propagation of high frequency acoustical signals. Of particular interest is the relationship between bubble distributions, surface gravity waves and turbulence and their effects on sound propagation. A second long-term goal is to model these processes to improve our understanding and to enhance the predictive capabilities. | | | | | |
| 15. SUBJECT TERMS | | | | | |
| 16. SECURITY CLASSIFICATION OF: | | | 17. LIMITATION OF ABSTRACT Same as Report (SAR) | 18. NUMBER OF PAGES 5 | 19a. NAME OF RESPONSIBLE PERSON |
| a. REPORT unclassified | b. ABSTRACT unclassified | c. THIS PAGE unclassified | | | |

Key individuals involved in the work:

- D M Farmer is an acoustical oceanographer responsible for project design and analysis
- S Vagle is an acoustical oceanographer responsible for implementation of acoustical systems, experimental execution and data analysis.
- G Deane is an acoustical oceanographer at Scripps who is collaborating in the research including both field studies and acoustic analysis
- J Preisig is a researcher from Woods Hole who is collaborating in both field studies and data analysis and interpretation.

WORK COMPLETED

The result of the accident the MVCO experiment (SPACE02), namely to obtain environmental measurements at the specular points of J. Preisig's acoustical arrays, was not met. Based on the experiences from this effort we have developed a new experimental plan and have rebuilt the instrumentation. This plan is less complex while ensuring that we obtain the essential bubble measurements relevant to interpretation of propagation effects on the communication path to be used by Jim Preisig..

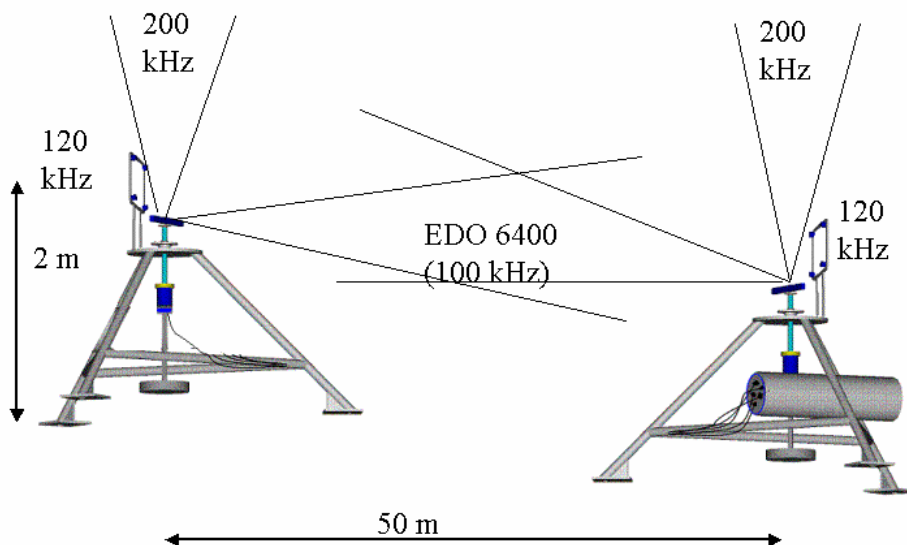

Figure 1. Diagram showing new instrumentation constructed for backscatter and propagation measurements in Narragansett Bay. Sonars are mounted on two tripods deployed approximately 50m apart.

A revised bistatic instrument has been constructed so as to allow a simple controllable experiment aimed at investigating propagation of high-frequency sound through dense bubble clouds (Figure. 1) while at the same time monitoring the surface and volume back scatter. Back-scatter Doppler measurements can be acquired at frequencies of 100 and 200kHz. Propagation measurements across the bistatic system can be made at a frequency of 120kHz. Finally, hydrophones are incorporated in the system so as to measure the sound made by breaking waves.

The bistatic measurements will be acquired with a square array of source/receivers using a 1m baseline. Sidescan sonars will be mounted on motor drives. The entire system will be deployed in Narragansett Bay close to the dock at the University of Rhode Island.



Figure 2. Propagation sonars and sidescan back scatter sonars mounted on two tripods prior to deployment in Narragansett Bay.

RESULTS

At the time of writing, the instruments have been built but not yet deployed. However, further work has been carried out on the behavior of acoustical resonators such as we used in the original SPACE02 experiment. Modeling analysis was carried out to better understand the performance of these sensors, especially in the light of recent studies carried out by Leighton on the influence of a reverberation on bubble resonance. Leighton's work focused on fixed bubble-cavity geometries. We have carried out detailed model calculations to determine the influence of reverberation on bubble resonance when the bubbles are randomly distributed in a freely flooding cavity such as the acoustical resonator we use for our measurements. An important result of these studies is that while we were able to confirm Leighton's prediction of the influence of reverberation on bubble resonance, we found that the impact for randomly distributed bubbles in a freely flooding cavity was confined to narrow peaks in the frequency domain. If these peaks coincide with the natural resonance frequencies of the resonator, the signal would be affected and the measurement perturbed. For the specific dimensions of the resonator used in our studies, the peaks do not coincide with the resonator harmonics and therefore do not cause a significant effect. A numerical scheme was developed to correct for the effect. The results have been published (Farmer, Vagle & Booth 2005).

IMPACT/APPLICATIONS

Considerations of the hydrodynamic impacts of the surface wave field, the bubbles and the turbulence are critical to the development of robust acoustical propagation models (Vagle, Farmer & Deane, 2001; Farmer, Deane & Vagle, 2001). The present studies and modeling efforts, combined with a revised experiment will improve our understanding of significant problems associated with sound propagation in the presence of bubbles and turbulence, especially as it applied to underwater acoustic communication. Analysis of the resonator performance, taking due account of reverberation effects, will provide added confidence in the use of this instrument in bubble measurements.

REFERENCES

Farmer, D.M., Vagle, S., and A.D. Booth, A free flooding acoustical resonator for measurement of bubble size distributions, . *J. Atm. Ocean. Techn.*, Vol. 15, 1132-1146, 1998.

Farmer, D.M., Deane, G.B., and S.Vagle The influence of bubble clouds on acoustic propagation in the surf zone. *IEEE J. Oceanic Engineering*. Vol. 26, No. 1, 113-124, 2001

Leighton, T.G., P. R. White, C. L. Morfey, J. W. L. Clarke, G. J. Heald, H. A. Dumbrell, and K. R. Holland (2002). "The effect of reverberation on the damping of bubbles," *J. Acoust. Soc. Amer.*, 112 (4), pp. 1366-1376.

Vagle, S., Farmer, D.M., and G.B. Deane, Bubble transport in rip currents, *J. Geophys. Res.* Vol. 106, 11677-11689, 2001.

PUBLICATIONS

Farmer, David M., Svein Vagle & Donald Booth, Reverberation effects in acoustical resonators used for bubble measurements, *J. Acous. Soc. Amer.*, 118(5), Nov, 2005.

Vagle, S., P. Chandler, and D.M. Farmer, Dense bubble clouds in the surf zone and their link to wave and bottom induced turbulence, *J. Geophys. Res.* 2004.