

Naval Research Laboratory

Washington, DC 20375-5000
NRL Publication 0062-2630 July 1986

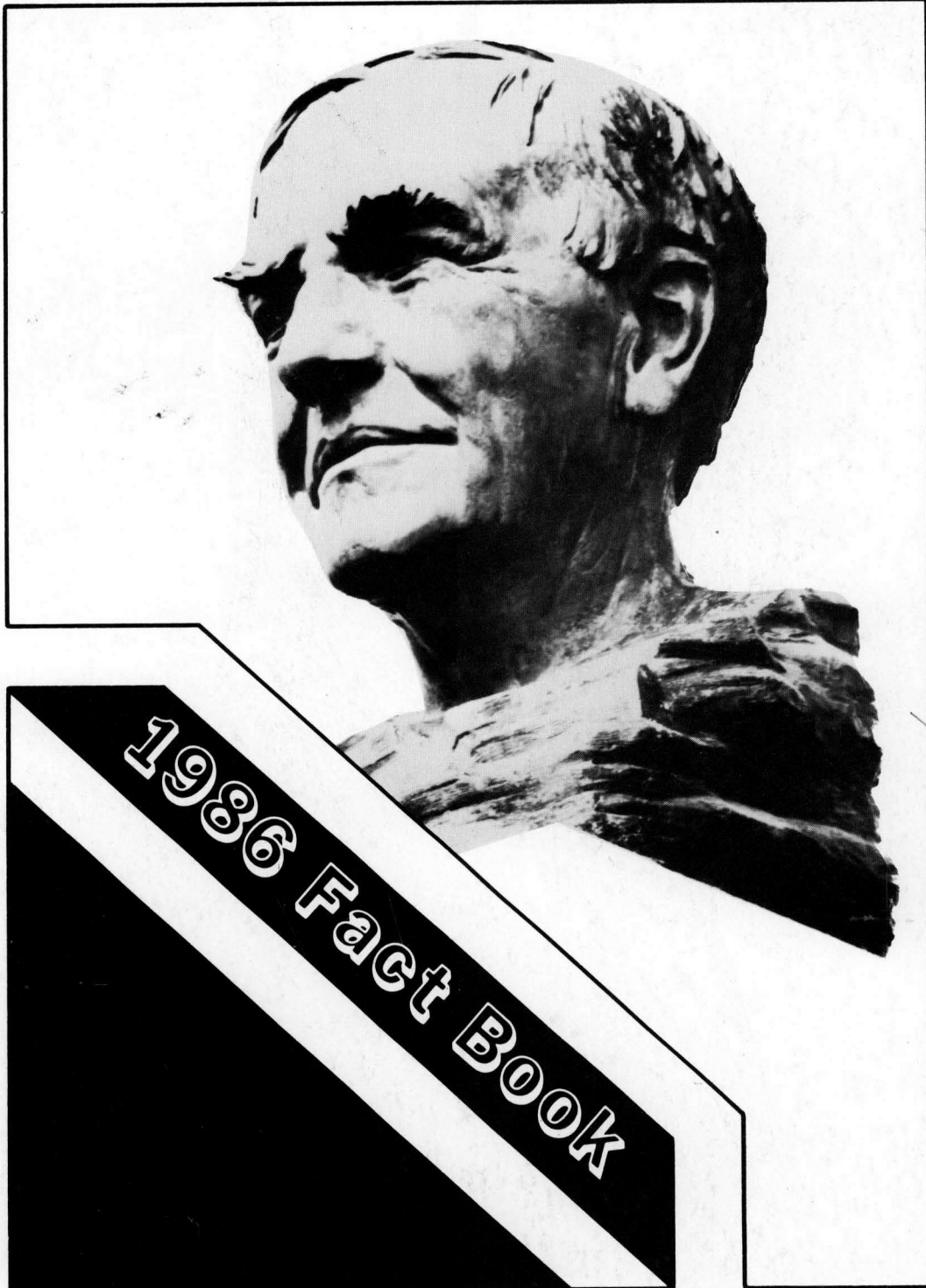

569844



1986 Fact Book

Report Documentation Page

Form Approved
OMB No. 0704-0188

Public reporting burden for the collection of information is estimated to average 1 hour per response, including the time for reviewing instructions, searching existing data sources, gathering and maintaining the data needed, and completing and reviewing the collection of information. Send comments regarding this burden estimate or any other aspect of this collection of information, including suggestions for reducing this burden, to Washington Headquarters Services, Directorate for Information Operations and Reports, 1215 Jefferson Davis Highway, Suite 1204, Arlington VA 22202-4302. Respondents should be aware that notwithstanding any other provision of law, no person shall be subject to a penalty for failing to comply with a collection of information if it does not display a currently valid OMB control number.

1. REPORT DATE JUL 1986		2. REPORT TYPE		3. DATES COVERED 00-00-1986 to 00-00-1986	
4. TITLE AND SUBTITLE NRL Fact Book				5a. CONTRACT NUMBER	
				5b. GRANT NUMBER	
				5c. PROGRAM ELEMENT NUMBER	
6. AUTHOR(S)				5d. PROJECT NUMBER	
				5e. TASK NUMBER	
				5f. WORK UNIT NUMBER	
7. PERFORMING ORGANIZATION NAME(S) AND ADDRESS(ES) Naval Research Laboratory, 4555 Overlook Avenue SW, Washington, DC, 20375				8. PERFORMING ORGANIZATION REPORT NUMBER	
9. SPONSORING/MONITORING AGENCY NAME(S) AND ADDRESS(ES)				10. SPONSOR/MONITOR'S ACRONYM(S)	
				11. SPONSOR/MONITOR'S REPORT NUMBER(S)	
12. DISTRIBUTION/AVAILABILITY STATEMENT Approved for public release; distribution unlimited					
13. SUPPLEMENTARY NOTES					
14. ABSTRACT					
15. SUBJECT TERMS					
16. SECURITY CLASSIFICATION OF:			17. LIMITATION OF ABSTRACT	18. NUMBER OF PAGES	19a. NAME OF RESPONSIBLE PERSON
a. REPORT unclassified	b. ABSTRACT unclassified	c. THIS PAGE unclassified			

The NRL Fact Book is prepared as a reference source for information about the Naval Research Laboratory. Unless otherwise noted, this information is current as of 30 September 1985. To provide more timely information, a point of contact is listed for various activities.

The Naval Research Laboratory has a continuing need for physical scientists, mathematicians, engineers, and support personnel. Vacancies are filled without regard to age, race, creed, sex, or national origin. Information concerning current vacancies will be furnished on request. Address all such inquiries to:

Civilian Personnel Office (Code 1810)
Naval Research Laboratory
Washington, DC 20375-5000

REVIEWED AND APPROVED
3 June 1986

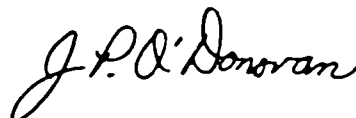
A handwritten signature in black ink that reads "J.P. O'Donovan". The signature is written in a cursive, flowing style.

CAPT J.P. O'Donovan, USN
Commanding Officer



INTRODUCTION TO THE
NAVAL RESEARCH LABORATORY



Mission

The mission of the Naval Research Laboratory is to conduct a broadly based, multidisciplinary program of scientific research and advanced technological development directed toward new and improved materials, equipment, techniques, systems, and related operational procedures for the Navy. In fulfillment of this mission, the Naval Research Laboratory:

- Initiates and conducts scientific research of a basic and long-range nature in scientific areas of special interest to the Navy.
- Conducts exploratory and advanced technological development deriving from or appropriate to the scientific program areas.
- Within areas of technological expertise, develops prototype systems applicable to specific projects.
- Performs scientific research and development for other naval commands and, where specially qualified, for other agencies of the Department of Defense and, in defense-related efforts, for other Government agencies.
- Upon request from appropriate naval commands, assumes responsibility as the Navy's principal R&D center in areas of unique professional competence.
- Serves as the principal activity for the Navy and its contractors in providing accurate calibration, test, and evaluation services on acoustic transducers and materials; in providing a service whereby an inventory of calibrated standard acoustic transducers is maintained for issue; and in performing research and development to advance the state-of-the-art of acoustic measurements and standard transducers.
- Performs research and development on sonar transducers and related acoustic materials.
- Furnishes scientific consultative services for the Navy and, where specially qualified, for other agencies of the Department of Defense and, in defense-related efforts, for other Government agencies.
- Provides to the Navy determinations of performance characteristics of developmental and prototype devices through limited engineering test and evaluation services.

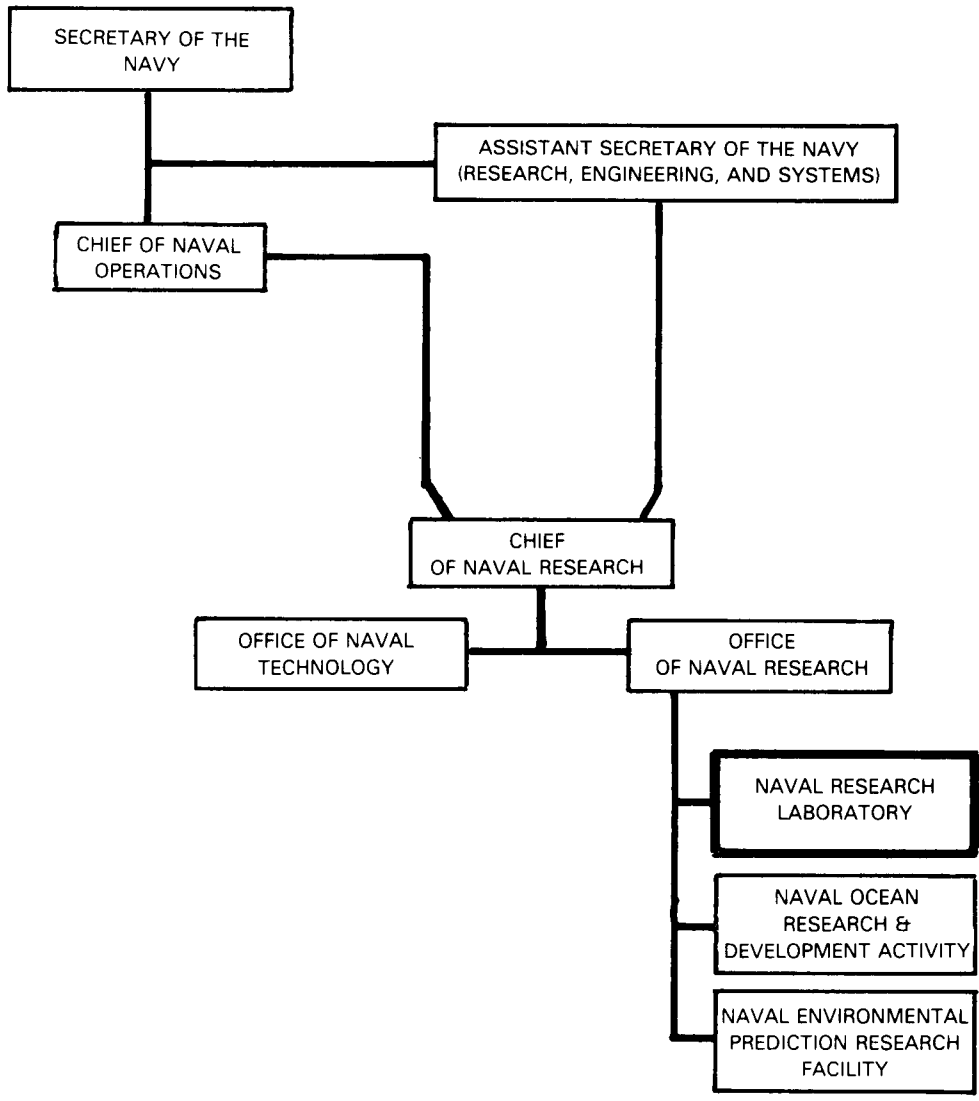



The Naval Research Laboratory in the Department of the Navy

The Naval Research Laboratory (NRL) is the principal in-house research laboratory of the Office of Naval Research (ONR) within the command of the Chief of Naval Research (CNR). As the corporate research laboratory of the Navy, NRL is an important component in ONR's effort to meet its scientific research responsibilities.

For its basic research effort, the Laboratory receives guidance from the Chief of Naval Research (CNR) that establishes the level of effort and trend direction. The Laboratory then develops a comprehensive research proposal package that is submitted to the CNR for consideration for Navy basic research support. The total Navy basic research program ultimately is evaluated by Congress.

In addition to internal critical review and the evaluation by the CNR and others, the research at NRL is published in refereed journals and/or reported at national and international scientific conferences. There is an aggressive policy of scientific interaction by which scientists from around the world visit NRL and are visited by NRL scientists. In this way, NRL research is subject not only to management review but also to peer evaluation.

NRL is an important link in the Navy R&D chain. Through NRL, the Navy has direct ties with sources of fundamental ideas in the academic community throughout the world and provides an effective coupling point to the R&D chain for the ONR contract research program.

NAVAL RESEARCH LABORATORY

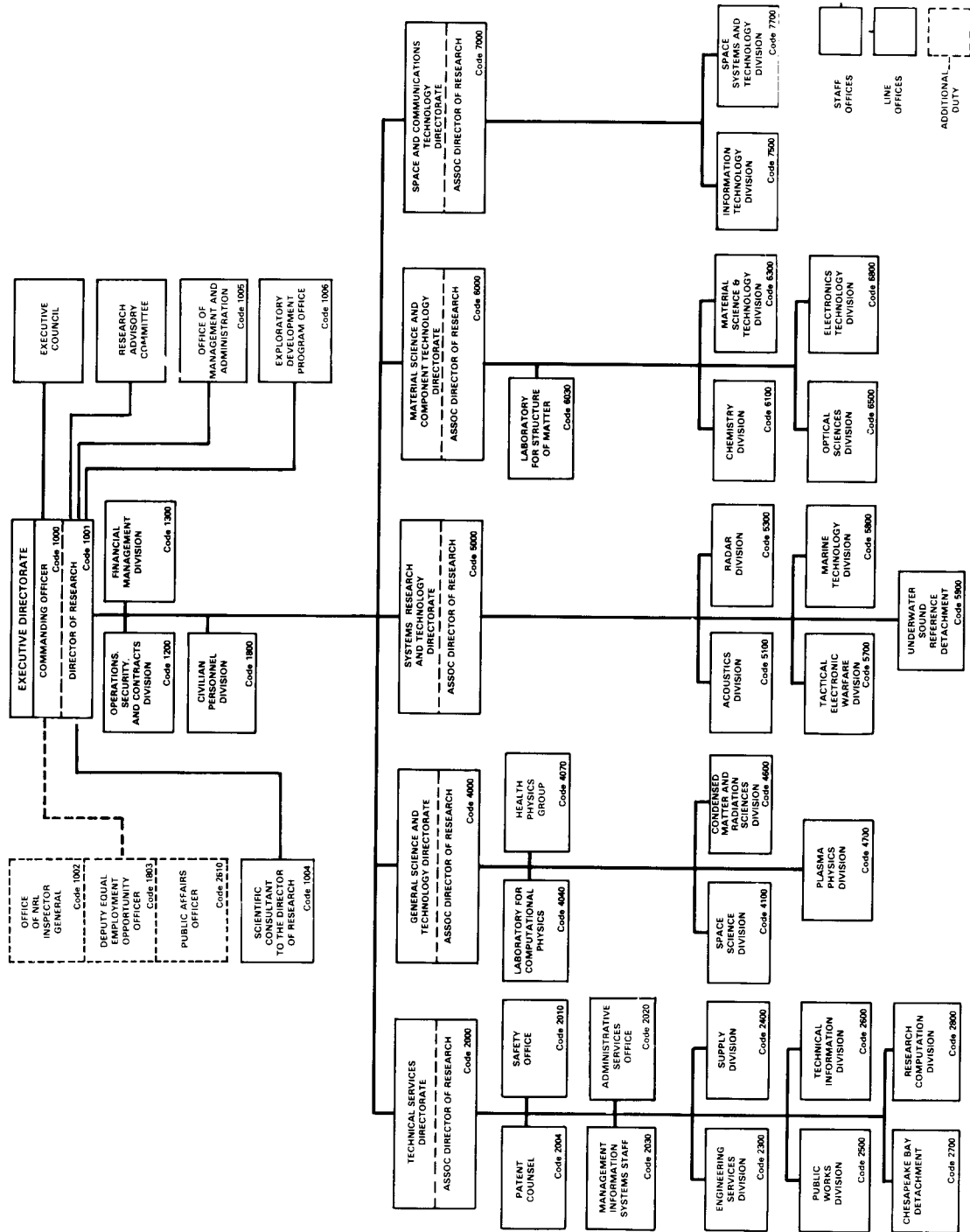

1 Patent Counsel to be transferred to Code 1200 July/August 1986

1 January 1986

CURRENT RESEARCH

The following areas represent broad fields of NRL research. Under each, more specific topics that are being investigated for the benefit of the Navy and other sponsoring organizations are listed. Some details of this work are given in the *NRL Review*, published annually. More specific details are published in reports on individual projects provided to sponsors and/or presented as papers for professional societies or their journals.

Computer Science and Artificial Intelligence

- Standard Computer Hardware, Development Environments, Operating Systems, and Runtime Support Software
- Methods of Specifying, Developing, Documenting, and Maintaining Software
- Techniques for Naval Needs
- Expert Systems for Resource Allocation, Signal Identification, Operational Planning, and Target Classification

Device Technology

- Integrated Optics
- Radiation-Hardened Electronics
- Microelectronics
- MM Wave Technology
- Hydrogen Masers for GPS

Directed Energy Technology

- High-Energy Lasers
- Chemical Lasers
- Laser Propagation
- High-Power Microwave Sources
- Charged-Particle Devices

Electronic Warfare

- Decoys (RF and IR)
- Repeaters/Jammers, EO/IR Active Countermeasures
- EW/C³CM System Concepts

Enhanced Maintainability, Reliability, and Survivability Technology

- Coatings
- Lubricants and Greases
- Water Additives and Cleaners
- Fire Safety
- Laser Hardening
- Satellite Survivability

Environmental Effects on Naval Systems

- Meteorological Effects on Electrooptical System Performance

- Air Quality in Confined Spaces
- Electromagnetic Background in Space
- Solar Activity
- Ionospheric Behavior

Information Management

- Antijam Communication Links
- Network Architectures
- Combat Management Information Systems

Materials

- Biomolecular Engineering
- Material Processing
- Advanced Alloy Systems
- Rapid Solidification Technology
- High-Temperature Materials
- Laser Fabrication and Processing
- Ceramics and Composite Materials

Space Systems and Technology

- Advanced Space Systems
- Space Sensing Applications
- Satellite Communications
- Spacecraft Design, Engineering, and Integration
- Satellite Ground Station Design
- Navigation Systems

Surveillance and Sensor Technology

- Imaging Radars
- Target Classification/Identification
- Towed Acoustic Arrays
- Underwater Acoustic Propagation
- Electromagnetic Sensors—Gamma Ray to RF Wavelengths
- SQUID for Magnetic Field Detection
- Low Observables Technology

Undersea Technology

- Autonomous Vehicles
- Bathymetric Technology
- Anechoic Coatings

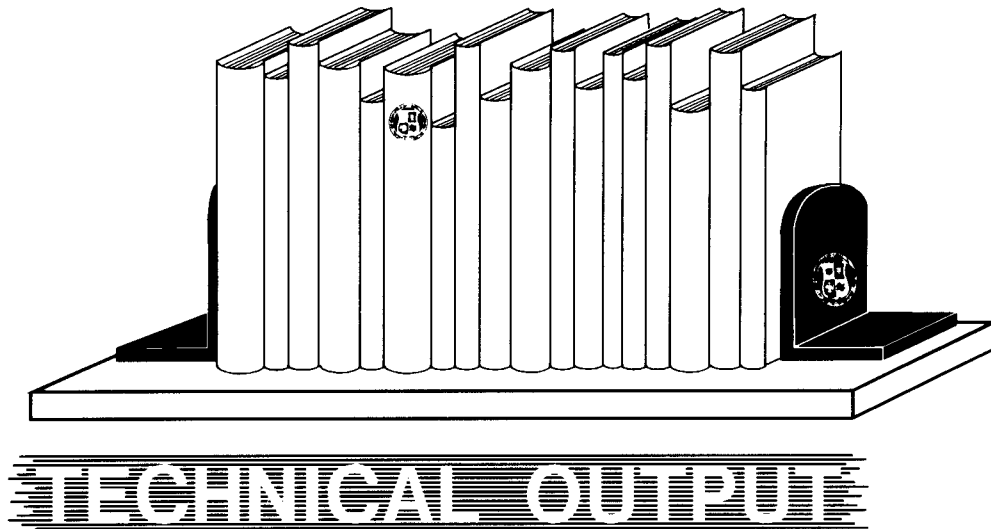

Publications

The results of research conducted at NRL are disseminated in many ways. The primary means of informing the scientific community and the general population of the advances made here is through publication. NRL research is published as journal articles, reports, and conference proceedings. Scientists here are also active in making presentations to a variety of audiences.

During fiscal year 1985, NRL researchers were authors of 426 journal articles, 243 NRL reports (both conclusive NRL Reports and NRL Memorandum Reports that describe preliminary results), and their work appeared in 235 conference proceedings; 1160 presentations were made to scientific, military, and government audiences.

Patents

One measure of a laboratory's scientific activity is the number of patents received. Since its establishment in 1923, NRL has been granted 3076 patents; during fiscal year 1985 alone, 69 have been granted.

The Navy actively patents its inventions to ensure Navy control over and free use of the technology it develops. A substantial number of inventions described in the patents issued to NRL have been incorporated into the Fleet.

Personnel*

Full-Time Civilians

Senior Executive Service		25
Classification Act (GM/GS)		2692
Scientific and Professional	1419	
Technical Support	461	
General Administrative & Clerical	750	
Other	62	
 Federal Wage System		 442
Wage Grade (WG)	383	
Apprentices (WT)	3	
Supervisory Wage Grade (WS)	33	
Supervisory Planners & Estimators (WN)	1	
Planners, Estimators, etc. (WD)	21	
Leaders (WL)	1	
 Total		 <hr style="width: 20%; margin-left: auto; margin-right: 0;"/> 3159

Military Personnel Attached to NRL

Officers	Authorized	On Board
Captain	3	3
Commander	7	6
Lieutenant Commander	10	11
Lieutenant	13	15
Lieutenant (Junior Grade)	2	1
Ensign	0	1
Warrant Officer	3	0
 Total	 <hr style="width: 20%; margin-left: auto; margin-right: 0;"/> 38	 <hr style="width: 20%; margin-left: auto; margin-right: 0;"/> 37
 Enlisted	 106	 100

Annual Civilian Turnover Rate (percent)

	<u>1981</u>	<u>1982</u>	<u>1983</u>	<u>1984</u>	<u>1985</u>
Research divisions	8.0	7.22	7.65	7.54	8.43
Nonresearch areas	10.9	8.25	11.70	16.15	11.68
Entire Laboratory	9.1	7.63	9.21	10.80	9.68

Highest Academic Degrees Held by Permanent Employees

Bachelors	555
Masters	319
Doctorates	705

*As of 30 Sept. 1985

Major Capabilities and Facilities

(Listed alphabetically by organizational unit)

Acoustics Division

Large tank instrumented for investigating acoustic echo characteristics of targets
Tank 9.1 m (30 ft) in diameter by 6.7 m (22 ft) deep, automated with computer control and analysis for detailed studies of acoustic fields, transducers, and other underwater devices
Multichannel Programmable Digital Data Processing System: a system of DEC computers, high-speed array processors, and peripherals for up to 256 channels; designed for acoustic surveillance array processing

Chemistry Division

Bio/Molecular Engineering Facility
Submicron Analytical Facility
Langmuir Blodgett Film Facility
Chemical Diagnostic Facility
Surface Diagnostic Facility
Tribology Facility
Paint and Coating Facility
Mechanical and Chemical Characterization of Polymers Facility
Surface Cleaning Facility
Alternate and Petroleum-Derived Fuels Facility
Combustion research facilities
High-Temperature Chemistry Facility
Fire research facilities
CAMECA Ion Beam Microprobe

Chesapeake Bay Detachment (CBD, Chesapeake Beach, MD)

Radar Experimental Test Site, which includes a variety of radars; ancillary equipment for test and evaluation of equipment, concepts and techniques; and overwater ranges
Tactical Electronic Warfare Test Site
Communications facilities for transmission to and from land, sea, and air
Hypervelocity gun for ballistics research
Ship Motion Simulator with 11-metric-ton (12-ton) payload capacity
Fire Test Facility for fire extinguishment research
Boat services

Condensed Matter and Radiation Sciences Division

Helium-3 Dilution Refrigerator
60-MeV Linear Electron Accelerator (Linac)

5-MV Positive Ion Van de Graaff Accelerator
Ion Implantation Facility
2-MV Electron Van de Graaff Accelerator
Cobalt-60 source
Hypervelocity gun ranges

Electronics Technology Division

Microelectronics Processing Facility
Electron beam lithography system
Electron microscopes and electrooptical analytical devices
High Resolution Scanning Electron Microscope/Scanning Transmission Electron Microscope
Crystal-growing facilities including Molecular Beam Epitaxy
High Magnetic Field Facility
A variety of electronic testing and analysis facilities

Engineering Services Division

Mechanical, electronic, and project engineering and design
Manual and computer-aided design and drafting
Printed circuit CAD/CAM facility (REDAC)
Shops for machining, sheet metal, welding, casting, plating, plastics, printed circuits, electronic assembly, and other fabrication services
A wide variety of testing and repair capabilities

Health Physics Staff

X-Ray and Gamma-Ray Calibration Facility

Information Technology Division

Microwave Space Research Facility
HF modem and channel simulation
Brandywine Antenna Range
Pomomkey Test Range
Signal Analysis Laboratory
Artificial Intelligence Computer Network

Laboratory for Computational Physics

VAX 11/780 plus peripherals, terminals, Network and MILNET, LANL X Cray and Net, APTEC DPS + FPS and NUMERIX Array Processors, Tektronix 4115 B and Evans Sutherland Graphics Stations, connected to the NRL Cray XMP—2M words, DEC frontend
DICOMED D-38 Design Station and NRL DICOMED microfilm recorder

Laboratory for Structure of Matter

Two X-ray diffractometers
Electron diffractometer

Marine Technology Division

Computer-aided experimental stress analysis
Shock and Vibration Laboratory
Wave channel: a 30-m channel with fan and mechanical wave-maker instrumented for the study of wave generation and wave effects
Water tunnel: a large blow-down water channel with a 15-m long test section for acoustic and flow-induced vibration studies of towed line arrays and flexible cables
Tow channel: a 20-m dual carriage tow channel with variable stratification for studies of geophysical flows and wakes

Material Science and Technology Division

Ultrasonic gas atomizer
Hot isostatic press
Consumable arc electrode melter for reactive metals
High energy dispersive X-ray analytical system
Electron microprobe SEM and STEM systems
Quantitative metallography
Computer-controlled multiaxial loading and SCC measurement systems
Computer interactive nonlinear multimode fracture measurement system
Crystallite orientation distribution function (CODF)
Impression creep and mechanical property evaluation
Automated physical constant measurement system
Closed-loop low and high-cycle fatigue systems
High energy CW and pulsed lasers
Hot cells for universal testing of irradiated materials

Operational Services

Mobile research platforms: three P3A, one P3B Orion aircraft. Three of the aircraft are especially configured for scientific support. The ASW suites have been removed, and the interiors have been converted for research project installations. One aircraft remains in Fleet ASW configuration.

Optical Sciences Division

Electron-beam, electron-beam sustained, X-ray, and UV preionized laser devices with spectroscopic and other diagnostic equipment
Short-pulse excitation apparatus for kinetic mechanisms investigations
Optical Warfare Laboratory

Mobile, high precision optical tracker
Facilities for synthesis and characterization of optical glass compositions and for the fabrication of optical fibers
Hybrid optical/digital image processing facility
Facilities for fabricating and testing integrated optical devices
Optical probes laboratory to study viscoelastic, structural, and transport properties of molecular systems
Computer IR/EO Technology/Systems Simulation Center
High Energy Pulsed Chemical Laser Laboratory
100-J UV Laser Research Facility
Field-qualified EO/IR measurements devices
Beam lines at the National Synchrotron Light Source, Brookhaven, for extensive materials characterization
Focal Plane Array Evaluation Facility

Plasma Physics Division

PAWN, 1-MJ Compact Inductive Storage Facility
Gamble I and II High-Voltage Pulsed Power Generators
PHAROS III, Three-Beam Neodymium-Glass Laser and Target Facility
1000-J NRL CO₂ Laser
7-MJ Homopolar Generator
High-Power Free-Electron Laser and Gyrotron Facilities
Modified Betatron Accelerator

Public Works Division

Construction, engineering, repair, and other services to maintain and improve NRL's physical facilities

Radar Division

Radar Cross Section Measurement System
Radar research and development test beds (at CBD)
Versatile C-, X-, and K_a-band monopulse precision tracking radar systems (at CBD)
IFF ground station
Interpretation facility for synthetic aperture radar (SAR)
Airborne APS-116 radar with SAR processing
Recording and control system for airborne adaptive array research
Noncooperative Target Recognition Facility
Antenna Measurement Laboratory
MADRE Over-the-Horizon Radar (at CBD)
Digital Image Processing Laboratory
Computer-Aided Engineering (CAE) Facility

Research Computation Division

Cray XMP-12 Computer (frontended by three DEC VAX 11/785 computers), an extremely large, high speed, powerful computational system particularly well-suited for scientific and engineering usage

DEC VAX 11/785s (3) Front end to the Cray XMP-12 computer, providing linkages to a wide variety of concurrent computer services to over 1200 scientists and engineers, both at NRL and at remote locations throughout the US. These services include high volume, time-shared, local and remote batch, active graphics, and telecommunications processing.

NRL Broadband Local Area Network (NICENET) that connects most NRL buildings for computer other communications and provides gateways to nation-wide communications/computer capabilities.

Off-line graphics capability via TID's DICOMED

CALCOMP 1055 and 5200 Plotting Facilities

VAX-11/780 MIS Computer

DEC-10 MIS Computer

VAX-11/750 Milnet Connection

Space Science Division

Waldorf Annex (lower site). This facility is instrumented for continuous recordings of atmospheric-electricity, micrometeorological, and lightning-flash data, and is utilized for numerous investigations into environmental phenomena.

Instrumented micrometeorological tower on San Nicolas Island, CA

Ionospheric sensing and propagation analysis 26-m (85-ft) radio telescope at Maryland Point, Md.

Other antennas for radio astronomy

E.O. Hulburt Center for Space Research

Development and test facilities for space-borne instruments to perform astrophysical, solar, high atmospheric, and space-environment sensing

Clean-room facilities

Extensive computer-assisted data manipulation and interpretive capability for space-data imaging and modeling

Space Systems and Technology Division

CAD/CAM Facility

R.F. Anechoic chambers

Thermal-vacuum chambers

Spin Balance Facility

Reverberation Chamber

Shock and Vibration Test Facility

Clean-room facilities

Satellite tracking, command, and control facilities

30.5-m (100-ft) wave tank for studying dynamics of wind waves and their interactions with long waves; uses microwave Doppler spectrometry and optical and photometric techniques

Spacecraft fabrication and assembly facility

Supply Division

Acquisition, storage, distribution, and disposal of materials and equipment required by the Research Directorates

Tactical Electronic Warfare Division

Mobile Infrared Signature Measurement and Simulation Facility

Mobile ESM Laboratory

Hybrid RF/IR Missile Seeker Simulation Facility

Central Target Simulation Facility for developing, testing, and evaluating EW systems and techniques, using real-time, hardware-in-the-loop models

RF Simulation Laboratory and signal simulators

Radar Cross-Section Measurement Facility (at CBD)

Search Radar ECM simulator

Advanced Tactical EW Environment Simulator

Technical Information Division

Editorial, graphic, photographic, and composition services; public affairs; technical library; exhibit and presentation support; and computer graphics services

Underwater Sound Reference Detachment (Orlando, FL)

2.8-hectare (7-acre) lake with a large pier and instrumentation for underwater acoustic studies

Anechoic tank for simulating ocean depths up to 700 m (2297 ft)

Smaller pressure vessels for simulating depths to 7000 m (22,966 ft)

Field station at Bugg Spring with floating platform and instrumentation for acoustic measurements

Major NRL Sites and Facilities

Station and Location	Acreage			Buildings and Structures
	Navy Title	Easement or Purchase	Permit or Lease	
District of Columbia				
NRL	129.23		1.29	154
Cyclotron building site, Bolling AFB			5.24	1
Virginia				
Midway Research Center, Quantico	162.00			
Maryland				
NRL Flight Support Detachment, NAS Patuxent River*†			—	
Chesapeake Bay Detachment, Chesapeake Beach†	167.90			194
Multiple research site, Tilghman Island†	2.00			14
Dock facility, Fishing Creek, Chesapeake Bay			0.60	6
NRL Waldorf Annex, Waldorf†	23.94	35.16		42
Radio Astronomy Observatory, Maryland Point†	24.30		197.88	22
Radio antenna range, USAF Receiver Site, Brandywine†			22.98	
Free Space Antenna Range, Pomonkey†	14.12	28.40		22
Satellite tracking facility, Blossom Point†			288.0	
Florida				
Underwater Sound Reference Detachment, Orlando†	10.46			49
USRD, Leesburg Facility, Bugg Spring			65.0	13
Totals:	533.95	63.56	580.99	517

*Site or equipment used by NRL under an intraservice (Navy) or interservice agreement.

†See maps, General Information section.

FISCAL INFORMATION

NRL FUNDING BY MAJOR SPONSOR (NEW ORDERS RECEIVED)

Sponsor	FY 1985		FY 1986	
	Actual (\$M)	Percent	Estimated (\$M)	Percent
ONR	71.5	18.1	72.0	20.9
CNM	2.6	.7	—	—
SPAWAR	67.1	17.0	58.3	16.9
NAVAIR	31.6	8.1	27.5	8.1
NAVSEA	36.0	9.1	31.0	9.0
Other Navy	107.0	28.4	86.1	26.1
	—	—	—	—
Total Navy	315.8	81.4	274.9	81.0
Other DoD	43.7	11.1	39.2	10.9
Non-DoD	35.0	7.5	30.2	8.1
	—	—	—	—
Total Non-Navy	78.7	18.6	69.4	19.0
	—	—	—	—
Total Funding	394.5	100.0	344.3	100.0

CAPITAL PROPERTY

Acquisition Value
(30 Sept 1985, \$K)

Class 1 (Land)	353
Class 2 (Buildings and improvements)	101,401
Class 3 (Equipment over \$1.0 K)	81,584
Class 4 (Industrial production equipment)	16,375
Class 5 (Minor property)	9,334
Class 0 (Sponsor-owned equipment)	44,782
	—
Total Capital Property	253,829

**SOURCES OF FUNDS
FY 1985 (NEW ORDERS RECEIVED)**

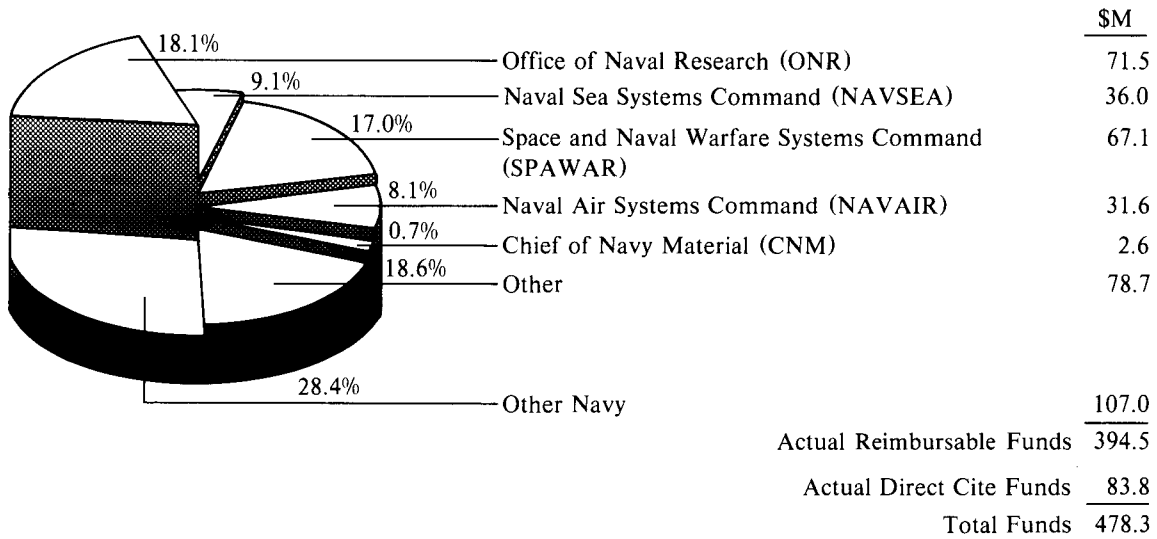

FY 1986 PLAN (NEW ORDERS)

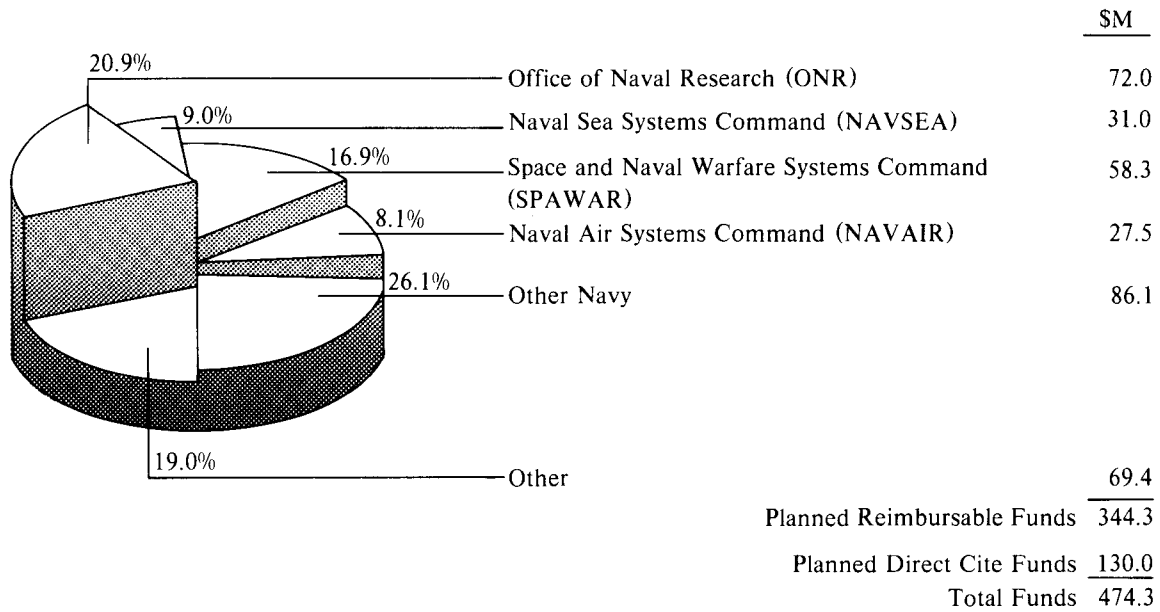

**RDT&E NAVY REIMBURSABLE FUNDS BY CATEGORY
FY 1986 PLAN (NEW ORDERS)**

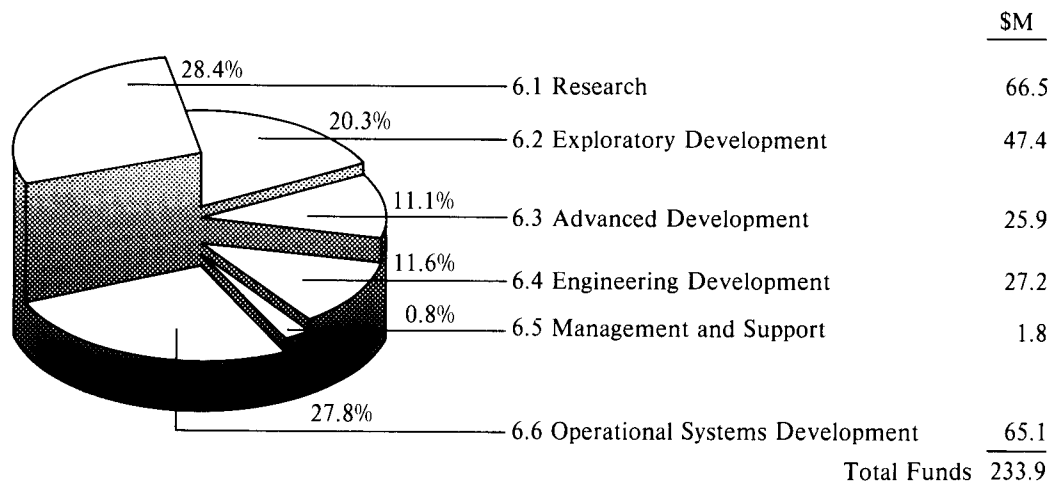

**DISTRIBUTION OF REIMBURSABLE FUNDS
FY 1986 PLAN**

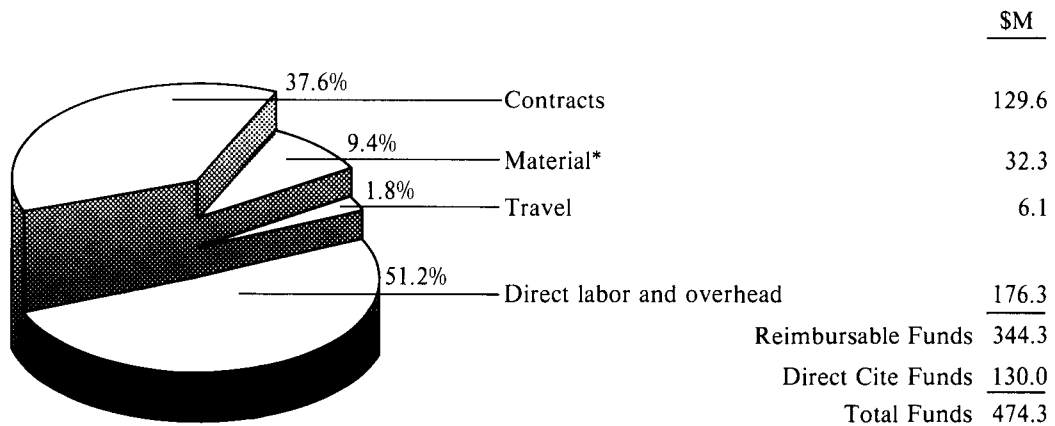

*Also includes other costs, such as ADP charges, tuition, etc.

**R&D PROGRAM FUNDS BY TYPE
(NEW ORDERS RECEIVED)**

Type or Purpose of Funds	FY 1985		FY 1986	
	Actual (\$M)	Percent	Planned (\$M)	Percent
Reimbursable Funds				
Research, Development, Test and Evaluation, Navy				
6.1 Research	63.7	16.2	66.5	19.3
6.2 Exploratory Development	54.2	13.7	47.4	13.7
6.3 Advanced Development	29.7	7.5	25.9	7.5
6.4 Engineering Development	30.9	7.9	27.2	7.9
6.5 Management & Support	2.3	0.6	1.8	.6
6.6 Operational Systems Development	<u>86.8</u>	<u>22.0</u>	<u>65.1</u>	<u>18.9</u>
RDT&E Navy Subtotal	267.6	67.9	233.9	67.9
Other RDT&E Subtotal	<u>73.1</u>	<u>18.5</u>	<u>63.9</u>	<u>18.5</u>
Total RDT&E	340.7	86.4	297.8	86.4
Other Procurement, Navy	7.4	1.9	5.6	1.7
Operation and Maintenance, Navy	14.2	3.6	11.3	3.3
Other	<u>32.2</u>	<u>8.1</u>	<u>29.6</u>	<u>8.6</u>
Total Reimbursable Funds	394.5	100.0	344.3	100.0
Direct Cite Funds	<u>83.8</u>		<u>130.0</u>	
Total Funds	478.3		474.3	

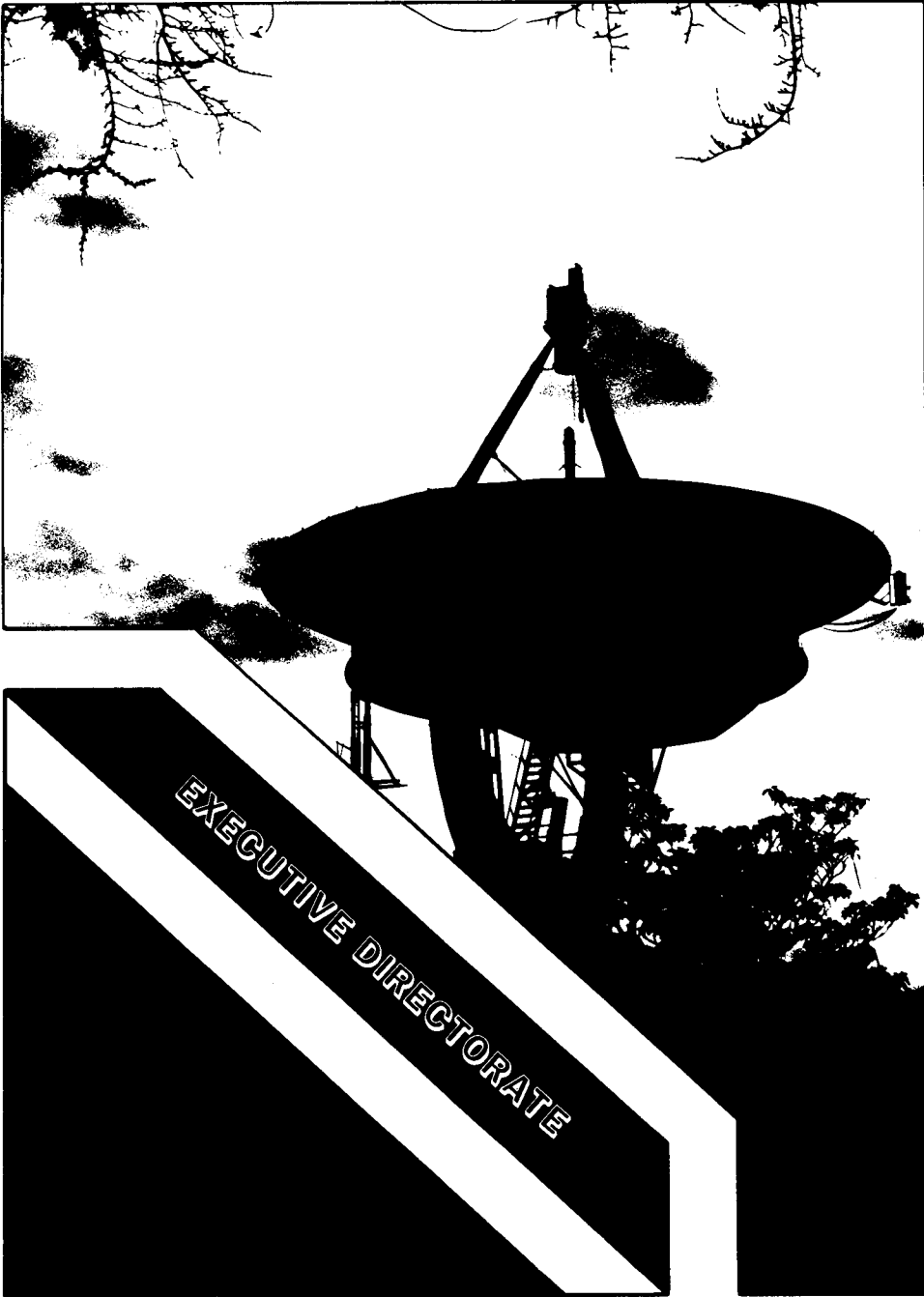

EXECUTIVE DIRECTORATE

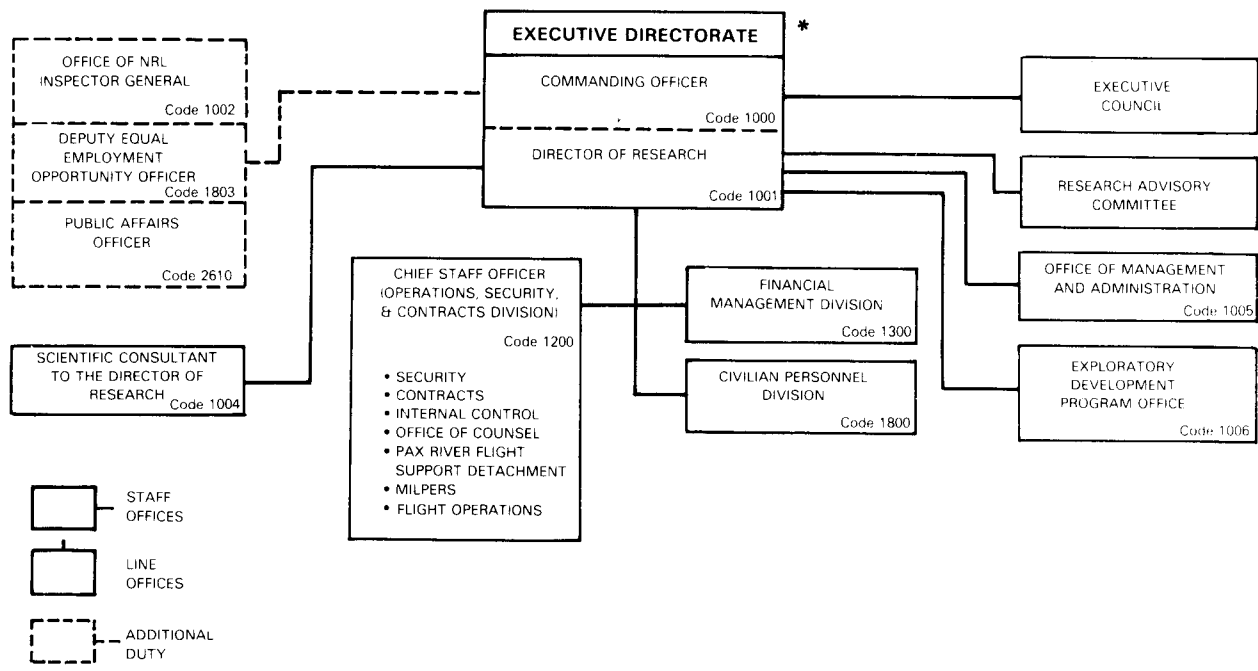

Key Personnel

Name	Title	Code
CAPT J.P. O'Donovan, USN	Commanding Officer	1000
Dr. T. Coffey	Director of Research	1001
Ms. Sol del Ande Eaton	Deputy Equal Employment Opportunity Officer	1803
CAPT J.P. Morris†	Inspector General	1002
Mr. J.W. Gately, Jr.	Public Affairs Officer	2610
Dr. P. Mange	Scientific Consultant to Director of Research	1004
Mrs. M. Oliver	Head, Office of Management and Administration	1005
Dr. S. Sacks	Head, Exploratory Development Program Office	1006
CAPT J.P. Morris, USN	Chief Staff Officer	1200
Mr. R.W. Steinbeck	Comptroller	1300
Mr. D.J. Blome	Head, Civilian Personnel Division	1800
Mr. J.D. Brown	Associate Director of Research for Technical Services	2000
Dr. W.R. Ellis	Associate Director of Research for General Science and Technology	4000
Mr. R.R. Rojas	Associate Director of Research for Systems Research and Technology	5000
Vacant	Associate Director of Research for Material Science and Component Technology	6000
Dr. B. Wald	Associate Director of Research for Space and Communications Technology	7000

*May 19, 1986
 †Additional duty

The Executive Directorate



The Commanding Officer and the Director of Research share executive responsibility for the management of the Naval Research Laboratory; however, in accordance with Navy regulations, the Commanding Officer is responsible for the overall management of the Laboratory and exercises the usual functions of command including compliance with legal and regulatory requirements, liaison with other military activities, as well as the general supervision of the quality, timeliness, and effectiveness of the technical work and of the support services.

The Commanding Officer delegates line authority and assigns responsibility to the Director of Research for the technical program, its planning, conduct, and staffing; evaluation of the technical competence of personnel; liaison with the scientific community; selection of subordinate technical personnel; exchange of technical information; and the effectiveness of the NRL mission.

Within the limits of Navy regulations, the Commanding Officer and the Director of Research share authority and responsibility for the internal management of the Laboratory. The Commanding Officer retains all authority and responsibility specifically assigned to him by higher authority.

The mission of the Laboratory is carried out by the four science and technology directorates supported by the Technical Services Directorate and the Executive Directorate. In addition, the Laboratory's operating staffs provide assistance in their special fields to the Commanding Officer and the Director of Research. The operating staffs are listed on the following pages of this publication.

Commanding Officer

Captain James P. O'Donovan, USN, was born in Newburgh, N.Y. on February 11, 1935. He attended Manhattan College in New York City, graduating in June 1956 with a bachelor's degree in electrical engineering. He was commissioned as an ensign from Officers' Candidate School in December 1956.

Upon completion of successive engineering assignments at the U.S. Naval Mine Defense Laboratory and as the Bureau of Ships Technical Representative to the IBM Corporation, he was ordered to the Naval Postgraduate School, where he earned a master of science degree in electronics engineering in 1962. Duty tours aboard the HORNET (CVS-12) as Electronics Officer and at the Long Beach Naval Shipyard in Design, Combat Systems, and Repair Department assignments preceded rotation in July 1967 to the newly established Naval Ship Engineering Center for duty as Assistant Naval Tactical Data Systems Project Officer. Promoted to commander in July 1970, he became Fleet Electronics Material Officer on the Staff of Commander Service Force, U.S. Pacific Fleet, in August 1971, with additional duty assigned in this capacity on the Staff, Commander-in-Chief, U.S. Pacific Fleet.

He was selected for promotion to captain in June 1977, while serving as the Director of Telecommunications in the Office of the Assistant Secretary of the Navy (Manpower, Reserve Affairs and Logistics).

In August 1977, Captain O'Donovan assumed command of the Naval Electronics Systems Engineering Center, Charleston, S.C., and remained in command for 30 months. He reported to the Naval Sea Systems Command in February 1980, as Program Manager, Navy Shipboard Embedded Computer Systems.

Captain O'Donovan's awards and service medals include the Meritorious Service Medal (three awards), the Navy Commendation Medal (two awards), the Navy Unit Commendation, the National Defense Medal with one star, and the Vietnam Service Medal with one star. Captain O'Donovan is a distinguished graduate of the Industrial College of the Armed Forces (1976) and earned a master of science degree in Administration from George Washington University in September 1976. He is a member of Sigma Xi and the American Society of Naval Engineers.

Director of Research

Dr. Timothy Coffey [REDACTED]. He graduated from the Massachusetts Institute of Technology in 1962, with a B.S. degree in electrical engineering, and obtained his M.S. (1963) and Ph.D. (1967), both in physics, from the University of Michigan.

During his graduate career, Dr. Coffey worked as a research assistant at the University of California (1963-64), a research physicist at the Air Force Cambridge Research Laboratories (1964-65), and a teaching fellow and research assistant in physics at the University of Michigan (1965-66). As a scientific consultant for EG&G, Inc. (1966-71), he was involved in investigations in theoretical and mathematical physics.

Dr. Coffey came to the Naval Research Laboratory in 1971, as Head of the Plasma Dynamics Branch, Plasma Physics Division. In this position, he directed research in the simulation of plasma instabilities, the development of multidimensional fluid and magnetohydrodynamic codes, and the development of computer codes for treating chemically reactive flows. In 1975, he was named Superintendent, Plasma Physics Division; he was appointed Associate Director of Research for General Science and Technology on January 1, 1980. On November 28, 1982, he was named Director of Research.

Dr. Coffey is recognized as an authority on the theory of nonlinear oscillations and has played a major role in the national program on high-altitude nuclear effects. The author or co-author of over 70 publications and reports, he has made several fundamental contributions to the theory of electron beam-plasma interaction and to the understanding of plasma processes in the earth's ionosphere.

Dr. Coffey is a fellow of the American Physical Society, a fellow of the Washington Academy of Sciences, and a member of Sigma Xi. Among Dr. Coffey's recent honors and awards are the Senior Executive Service Performance Award and the Rear Admiral William S. Parsons Award for Scientific and Technical Progress (honorable mention). In 1981, he was awarded the Presidential Rank of Meritorious Executive.

Executive Council



Executive Council

The Executive Council consists of executive, management, and administrative personnel. The monthly Executive Council meeting is a scheduled forum that provides the Commanding Officer a personal means to relay new policy or changes to current policy that affect all divisions, as well as allowing the other members of the Council to advise the Commanding Officer and Director of Research on matters relating to the administration of the Laboratory. The council also provides an opportunity for information exchange among its members. The Executive Council members include:

- Commanding Officer, Chair
- Director of Research
- Chief of Staff Officer
- Associate Directors of Research
- Heads of Divisions
- Deputy Equal Employment Opportunity Officer
- Engineering Services Officer
- Supply Officer
- Public Works Officer
- NRL Counsel
- Head, Administrative Services Office
- Head, Management Information Systems Staff
- Head, Mechanical Engineering/Manufacturing Branch
- Head, Electrical Engineering/Manufacturing Branch
- Head, Maintenance, Utilities and Transportation Branch
- Head, Information Services Branch
- Head, Laboratory for Computational Physics
- Head, Laboratory for Structure of Matter
- Medical Officer

Research Advisory Committee



Research Advisory Committee

The Research Advisory Committee advises the Commanding Officer and the Director of Research on the scientific program and on the administration of the Laboratory. The committee assists in planning the long-range scientific program, coordinating the scientific work, reviewing the budget, accepting or modifying problems, considering personnel actions, and initiating such studies as may be necessary or desirable. The membership consists of:

- Director of Research, Chairperson
- Commanding Officer
- Associate Directors of Research
- Chief Staff Officer, Observer
- Legal Counsel, Observer
- Head, Office of Management and Administration, Recorder

Deputy Equal Employment Opportunity Officer



Ms. Sol del Ande Eaton

The Deputy Equal Employment Opportunity Officer is the EEO program manager and the advisor to the Commanding Officer on all EEO matters. She manages the discrimination complaint process and directs the Laboratory's affirmative action plans and special emphasis programs (Federal Women's, Hispanic Employment, Handicapped, and Disabled Veterans). Duties include reviewing, coordinating, and monitoring implementation of EEO policies and developing local guidance, directives, and implementation procedures for the EEO programs. She also advises SES and Merit Pay System employees on setting EEO objectives.

Public Affairs Officer

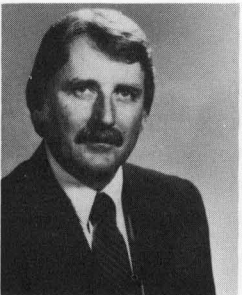

Mr. J.W. Gately, Jr.

The Public Affairs Officer (PAO) advises the Commanding Officer and Director of Research on public affairs matters, including external and internal relations, and serves as the Commanding Officer's principal assistant in the area of public affairs. To do this, the PAO plans and directs a program of public information dissemination on official NRL activities. The PAO coordinates responses to requests from the news media and the public for unclassified information or materials dealing with the Laboratory, coordinates participation in community relations activities, and directs a program of internal information dissemination within the Laboratory. The PAO is also responsible for coordinating all actions within the Laboratory that respond to requirements of the Freedom of Information Act (FOIA).

Scientific Consultant to the Director of Research



Dr. P. Mange

The Scientific Consultant carries out studies and analyses relating to the technical programs being carried out at the Laboratory on behalf of the Director of Research. He represents the Laboratory on external technical boards, advisory panels, or working groups as requested by the Director of Research and is the Laboratory point of contact with the Strategic Defense Initiative Organization.

1986 Fact Book

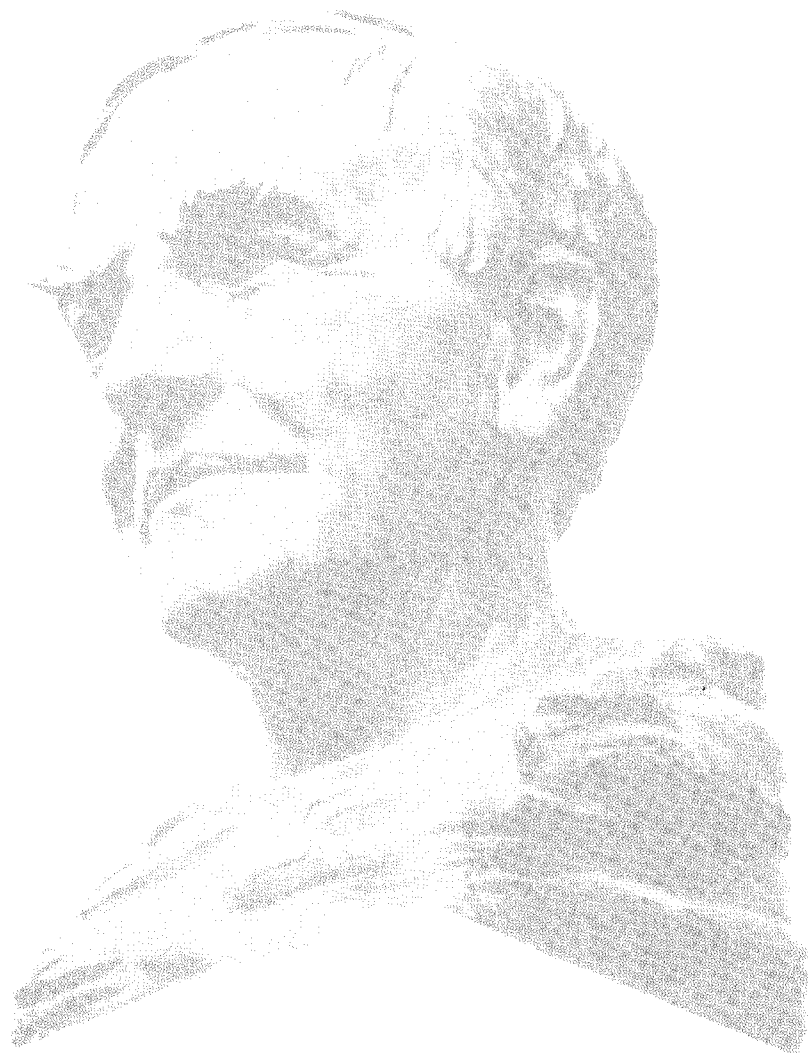

**Naval Research Laboratory
Washington, DC 20375-5000**

CONTENTS

INTRODUCTION TO THE NAVAL RESEARCH LABORATORY	1
Mission	3
The Naval Research Laboratory in the Department of the Navy	5
Organization Chart	6
Current Research	7
Technical Output	8
Personnel	9
Major Capabilities and Facilities	10
Major NRL Sites and Facilities	13
Fiscal Information	14
EXECUTIVE DIRECTORATE	21
Commanding Officer, Director of Research	23
Executive Council	24
Research Advisory Committee	25
Office of Management and Administration	27
Operations, Security, and Contracts Division	28
Financial Management Division	30
Civilian Personnel Division	32
TECHNICAL SERVICES DIRECTORATE	37
Office of Patent Counsel	40
Safety Office	40
Administrative Services Office	41
Management Information Systems Staff	41
Engineering Services Division	42
Supply Division	44
Public Works Division	46
Technical Information Division	48
Chesapeake Bay Detachment	50
Research Computation Division	52
GENERAL SCIENCE AND TECHNOLOGY DIRECTORATE	57
Health Physics Group	61
Space Science Division	62
Condensed Matter and Radiation Sciences Division	64
Plasma Physics Division	66
Laboratory for Computational Physics	68
SYSTEMS RESEARCH AND TECHNOLOGY DIRECTORATE	71
Acoustics Division	74
Radar Division	76
Tactical Electronic Warfare Division	78
Marine Technology Division	80
Underwater Sound Reference Detachment	82
MATERIAL SCIENCE AND COMPONENT TECHNOLOGY DIRECTORATE	87
Laboratory for Structure of Matter	91
Chemistry Division	92
Material Science and Technology Division	94
Optical Sciences Division	96
Electronics Technology Division	98
SPACE AND COMMUNICATIONS TECHNOLOGY DIRECTORATE	103
Information Technology Division	106
Space Systems and Technology Division	108
PROFESSIONAL DEVELOPMENT	113
Programs for NRL Employees	113
Programs for Non-NRL Employees	116
Awards Received by Civilian Employees in FY 1985	118
GENERAL INFORMATION	121
Location of NRL in the Capital Area	121
Location of Buildings at Main Site	122
Location of Field Stations in the Washington, D.C. Area	123
Chesapeake Bay Detachment (CBD)	124\
Location of Buildings at CBD	125
Underwater Sound Reference Detachment (USRD)	126
Key Personnel	127

Office of Management and Administration

(Code 1005)

Basic Responsibilities

The Office of Management and Administration provides managerial, technical, and administrative support to the Director of Research in his planning and direction of research and development programs in a variety of scientific and engineering disciplines. Specific functions include: performing special studies involving major NRL programs and resource issues; providing administrative support in the areas of personnel, budget, facilities, equipment, and security; reviewing and managing director of research correspondence; providing management information and analyses for various aspects of the research program effort; coordinating NRL's Technology Transfer Program; coordinating VIP and foreign visits to NRL; managing the NRL Directives System; coordinating unsolicited proposals, congressional correspondence, and other external inquiries; maintaining the NRL R&D achievements file; reviewing and interpreting external Navy and DoD directives addressed to NRL; managing the Defense Retail Interservice Support Program (Host-Tenant Agreements); coordinating the IR&D Program; developing guidance for and monitoring the 6.1 (basic research) Program and 6.2 (exploratory development) Program; providing central word processing services to the Directorate; coordinating the NRL-NRC and ONT Postdoctoral Resident Research Associateship Programs, 'NRL-US Naval Academy Faculty Coop Program, Navy ASEE Program, and other special Navy programs; interacting with ONR Headquarters and the R&D Centers as laboratory representative; developing NRL's Five-year Plan; and serving as liaison for all contacts with, and inquiries from, OMB, GAO, and other Government audit agencies.



Mrs. M. Oliver

Key Personnel

Name	Title
Mrs. M.C. Oliver	Head, Office of Management and Administration
Mr. D.J. DeYoung	Special Assistant
Ms. B.J. McDonald	Administrative Assistant
Mr. R. Fulper, Jr.	Head, Technology Transfer and Special Programs Staff
Mr. R.C. Spragg	Head, Management Information Staff
Vacant	Head, Directives Staff

Personnel

Full-time civilian: 28

Point of contact: Ms. B.J. McDonald, Code 1005.2, 767-3634

Operations, Security, and Contracts Division

- FLIGHT DETACHMENT
- CONTRACT STAFF SERVICES
- PERSONNEL AND PHYSICAL SECURITY
- PROCUREMENT SERVICES



Operational Services

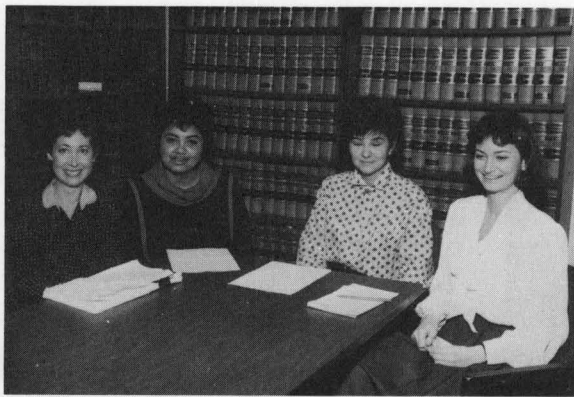

Legal Staff



Physical Security

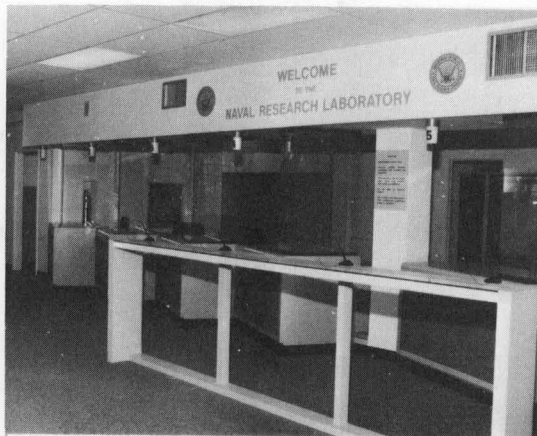

Visitor Control



CAPT J.B. Morris, USN

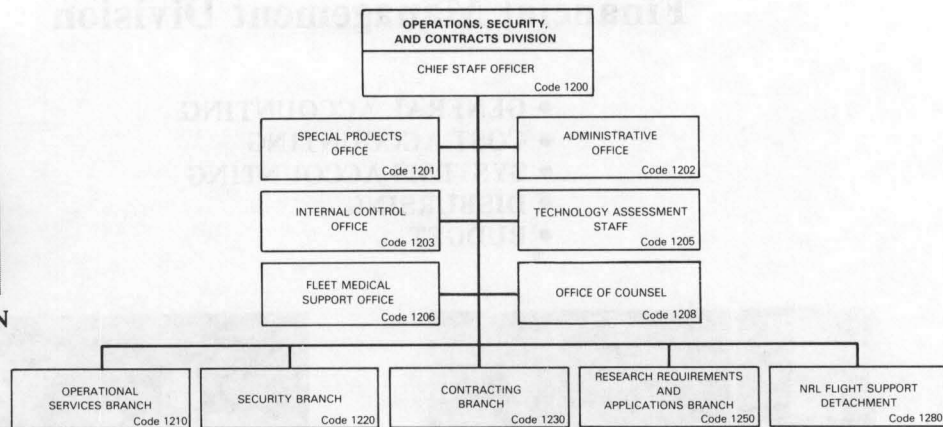

Basic Responsibilities

The Operations, Security, and Contracts Division is headed by the Chief Staff Officer who serves as the Deputy to the Commanding Officer and acts for the Commanding Officer in his absence. The Chief Staff Officer is the Laboratory's Inspector General, and he coordinates NRL's Research Reserve program.

The Division provides a military staff to the Commanding Officer and to the Director of Research for the purpose of direct research support and assisting in the military aspects of the management of the Laboratory. The staff is the liaison with DOD, Navy commands/activities, and the operating forces of the Navy. It supports NRL research and development operations and coordinates military applications of the scientific work of the Laboratory. Direct research support is provided through operations of four multiengine Laboratory aircraft. In addition, the staff arranges for air, surface, and subsurface services as required by research and development operations.

The Division is responsible for physical, personnel, communications, information, and ADP security as well as fire protection. It provides intelligence support and support for international cooperative agreements in technology control, compiling and maintaining a comprehensive technical data base which include the Military Critical Technologies List and register of technical experts. It is further responsible for conducting research in medical support for wartime and civilian disaster management planning.

The Division provides the major procurement services which include consultant/advisory contract staff services, as well as administration and monitoring of contract performance. It provides legal counsel and services in the fields of procurement, business and commercial law, civilian personnel law, and government regulations, and laws which affect the Laboratory. The staff also coordinates the Laboratory's internal control program.

Key Personnel

Name	Title
CAPT J.B. Morris, USN	Chief Staff Officer
CDR G.R. McWilliams, USN	Special Projects Coordinator
Ms. M.L. Bond	Administrative Officer
Ms. M.S. Rathbun	Internal Control Officer
Mr. L.M. Winslow	Head, Technology Assessment Staff
Dr. P.B. Richards	Head, Fleet Medical Support Office
Ms. S.G. Weldon	Legal Counsel
CDR J.P. Kirkendall, USN	Operational Services Officer
Mr. J.R. Gallagher	Communications/Message Center
Mr. M.B. Ferguson	Head, Security Branch
Mr. F. Washington	Head, Classification Management and Control Section
Mr. W.C. Bryan	Head, Special Security Office/Special Activities Office
Mrs. S.A. Cornwell	Head, Personnel and Physical Security Section
Mr. J. Ablard	Head, Contracting Branch
CDR T.E. Frazier, USN	Head, Research Requirements and Applications Branch
CDR D.P. Glanzman, USN	Head, OIC, NRL Flight Support Detachment

Personnel

Full-time civilian: 134 Military: 90

Point of Contact: Ms. M.L. Bond, Code 1202, 767-3204

Financial Management Division

- GENERAL ACCOUNTING
- COST ACCOUNTING
- SYSTEMS ACCOUNTING
- DISBURSING
- BUDGET

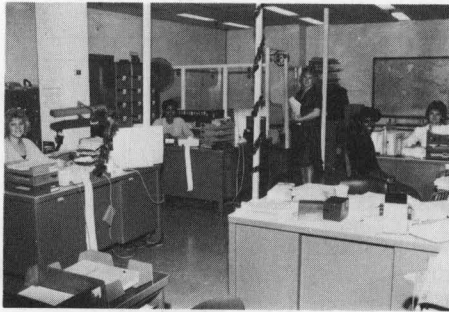

Travel Orders

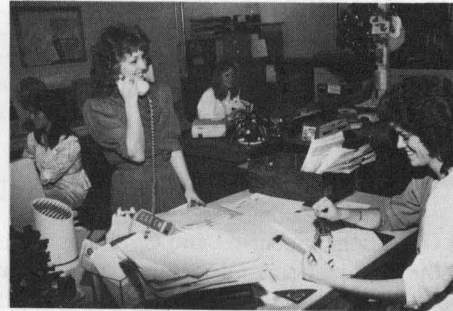

Fiscal

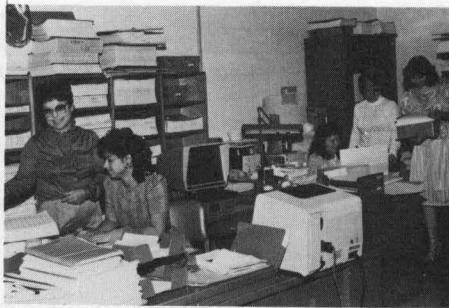

General Accounting



Cost Accounting

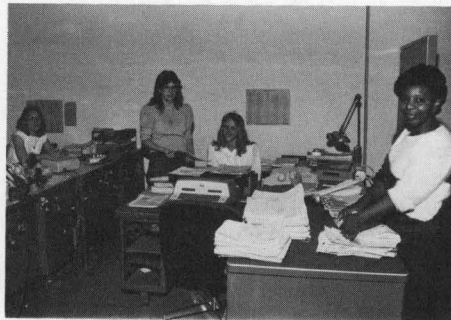

Travel Audit



Administrative Support

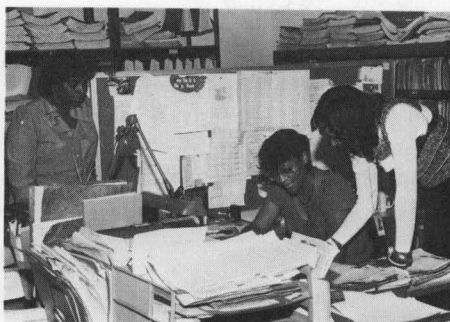

Payroll



Budget

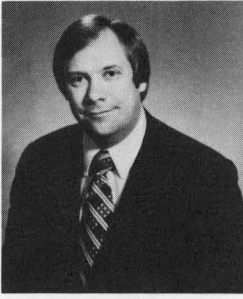

Mr. R.W. Steinbeck

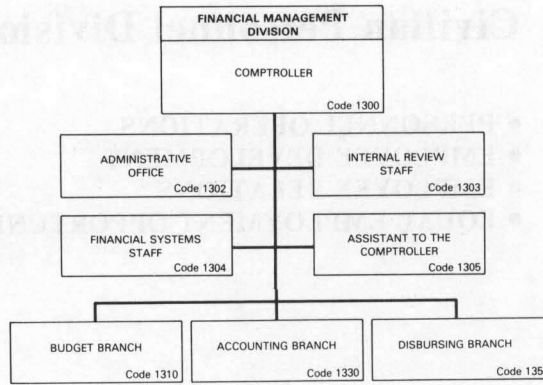

Basic Responsibilities

The Comptroller is the financial adviser to the Commanding Officer, the Director of Research, and other officials of the Laboratory, and administers the financial program of the Laboratory.

The Financial Management Division provides service to the Laboratory in budget formulation and funds administration, program and budget analysis, accounting and reporting, and disbursing. In addition, it provides internal review and control services to protect the integrity of the Laboratory's financial operations.

Key Personnel

Name	Title
Mr. R.W. Steinbeck	Comptroller
Mr. T.J. Santmyer	Deputy Comptroller
Mrs. D.E. Erwin	Administrative Officer
Vacant	Head, Financial Systems Staff
Mr. E.S York	Assistant to the Comptroller
Vacant	Head, Budget Branch
Mr. M.C. Mills	Head, Accounting Branch
Mrs. H. McCauley	Head, Disbursing Branch

Personnel

Full-time civilian: 91

Point of contact: Mrs. D. Erwin, Code 1302, 767-2950

Civilian Personnel Division

- PERSONNEL OPERATIONS
- EMPLOYEE DEVELOPMENT
- EMPLOYEE RELATIONS
- EQUAL EMPLOYMENT OPPORTUNITY

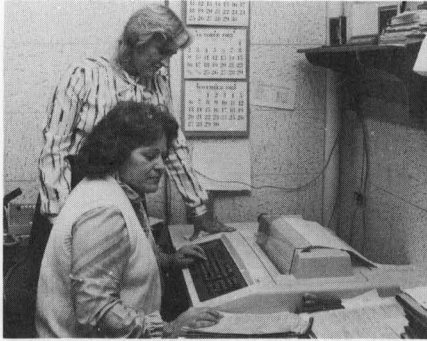

Personnel Actions, Records, and Reports



EEO Staff

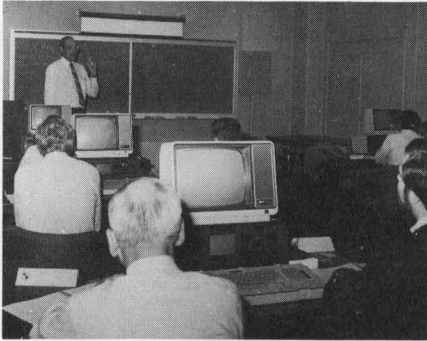

Training—Management Use of Personal Computers

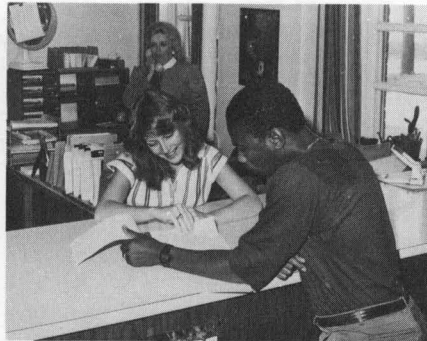

Personnel Operations Reception Area



Employee Relations

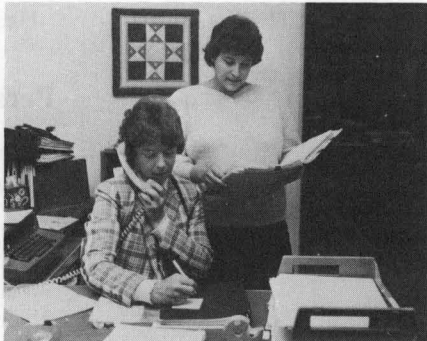

Providing Employment Information



Mr. D.J. Blome

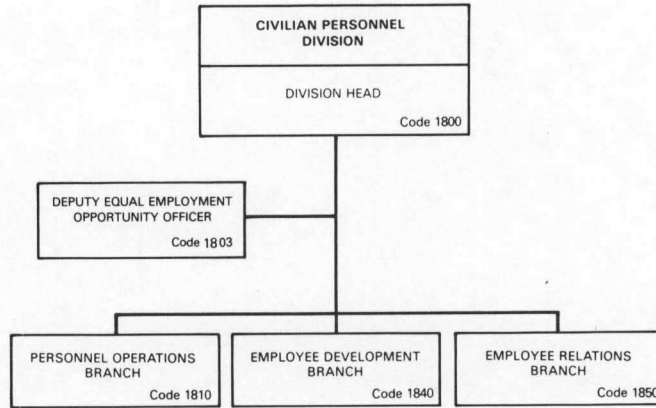

Director of Civilian Personnel

The Director of Civilian Personnel (ONR Code 790) of the Consolidated Civilian Personnel Office (Headquarters, ONR, NRL, and Naval Ocean Research & Development Activity) is Mr. F.D. Wallace. His office is located at the Office of Naval Research, Ballston Towers #1, 800 North Quincy Street, Arlington, VA 22217. The on-site NRL division head is Mr. D.J. Blome.

Basic Responsibilities

The Civilian Personnel Division administers the Laboratory's personnel program, which includes selection, development, promotion, utilization, appropriate recognition, and employee counseling and services for all civilian personnel.

Key Personnel

Name	Title
Mr. F.D. Wallace	Director of Civilian Personnel (ONR Code 790)
Mr. D.J. Blome	Head, Civilian Personnel Division
Mrs. P.L. Hetzler	Administrative Officer
Ms. S. Eaton	Deputy Equal Employment Opportunity Officer
Ms. G. Van Hoosier	Federal Women's Program Manager
Ms. D.B. Cohen	Handicap/Hispanic Program Manager
Mr. D.J. Blome†	Head, Personnel Operations Branch
Mrs. B.A. Duffield	Employment Programs Manager
Mrs. C.A. Lowell	Classification and Pay Administration
Mr. A.H. Sass	Head, Employee Development Branch
Mr. F. Carter	Head, Employee Relations Branch

Personnel

Full-time civilian: 49

Point of contact: Mrs. P. L. Hetzler, Code 1802, 767-3421

†Additional duty



Technical Services Directorate

The Technical Services Directorate provides administrative and technical services required to support the mission of the Laboratory. This support is in the areas of technical information; facility construction and maintenance; engineering design and fabrication, supply; operating and maintaining the Laboratory's central computer facilities; and providing administrative information to management. In addition, the Directorate operates and maintains a field facility for NRL research at the Chesapeake Bay.



The Integrated Library System Provides Quick Local and Remote Access to the Library Book Collections



Aerial View of Chesapeake Bay Detachment



Sorting the Mail



Environmental/Workplace Monitoring



Central Computer Facilities

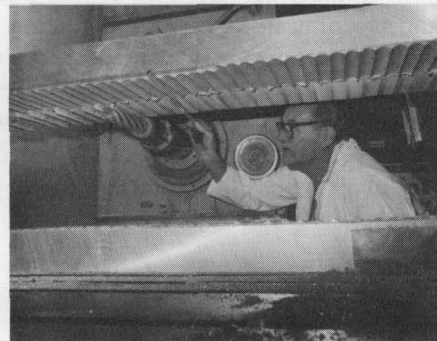

Programmable Vertical Milling Machine

Associate Director of Research for Technical Services



Mr. Jack D. Brown

Mr. Brown [REDACTED] He graduated from Michigan State University in 1943, with a BS degree in Physical Chemistry. He was called to active duty in the U.S. Army in 1943, and remained on active duty until he joined the Naval Research Laboratory on March 1, 1971.

Mr. Brown served as Associate Superintendent of the Plasma Physics Division from 1971 to 1981 when he was assigned duties as Associate Director of Research for Technical Services. In addition to his regular duties, he has been responsible for organization and operation of a number of Laboratory-wide multidisciplinary study efforts on nonacoustic ASW and anomalous geophysical phenomena.

During his military service, Mr. Brown was designated an Atomic Energy Specialist and engaged in research and teaching in long-range detection of nuclear explosions, development and testing of nuclear weapons, and the effects of nuclear explosions in space. During this period he planned or served as technical director for nuclear effects tests in space, underground, and over open ocean. He also organized and coordinated major geophysical expeditions to observe solar eclipses and polar cap ionospheric events. From 1952 to 1953 he served as a guest scientist at the National Bureau of Standards where he investigated the infrared emissivity of metals at cryogenic temperatures.

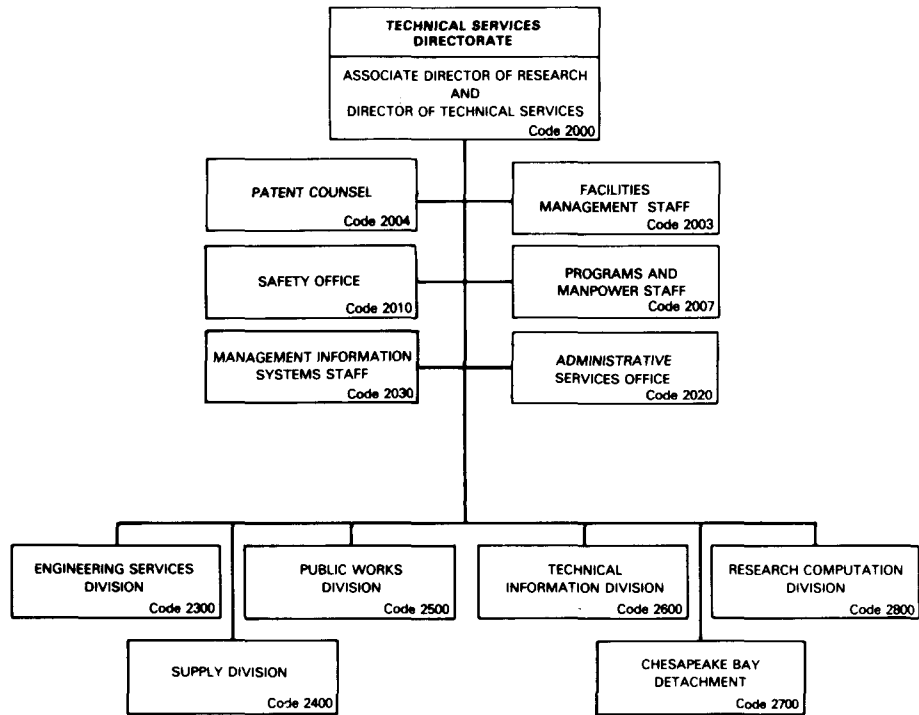

Key Personnel

Name	Title	Code
Mr. J.D. Brown	Associate Director of Research for Technical Services	2000
Mr. R. Flournoy	Support Planning Office	2002
Mr. R. Veith ¹	Head, Facilities Management Staff	2003
Mr. S. Sheinbein* ²	Patent Counsel	2004
Mrs. J. Cummings	Head, Programs and Manpower Staff	2007
Mr. H.C. Kennedy, Jr.	Safety Officer	2010
Mrs. L.V. Dabney	Head, Administrative Services Office	2020
Mr. R. Guest	Head, Management Information Systems Staff	2030
LCDR M.L. Crouch, USN	Engineering Services Officer	2300
LCDR T.R. Lippert, SC, USN	Supply Officer	2400
CDR J.P. Collins, CEC, USN ³	Public Works Officer	2500
Mr. P. Imhof	Head, Technical Information Division	2600
LT J.P. Dell*	Chesapeake Bay Detachment Officer	2700
Mr. R.F. Saenger	Head, Research Computation Division	2800

Point of contact: Mr. J.D. Brown, Code 2000, 767-2789

*Acting

¹Facilities Management Staff disestablished. Functions and personnel transferred to Code 2002 effective 3-1-86

²Patent Counsel to be transferred to Code 1200 July/August 1986

³CDR Collins transferred 5/23/86. New PWO CDR T.R. Rampe

Office of Patent Counsel¹

(Code 2004)

Basic Responsibilities

The Office of Patent Counsel provides services concerning inventions, patents, patent royalty charges, trademarks, copyrights, technical data rights, computer software licensing, and other related matters. Patent applications are prepared, filed, and prosecuted on NRL inventions of significance to the Federal government. The patent counsel serves as consultant and adviser on patent and data clauses in research and development and procurement contracts, claims of patent or copyright infringement involving NRL, and the provisions in interagency agreements relating to inventions, patents, trademarks, copyrights, and related matters. Assistance is provided to the research directorates through state-of-the-art searches in the patent literature pertinent to particular research problems.

Key Personnel

Name	Title
Mr. S. Sheinbein*	Patent Counsel

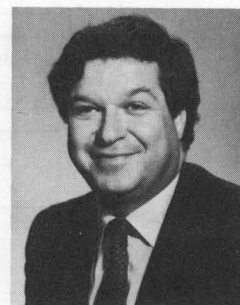

Mr. S. Sheinbein

Personnel

Full-time civilian: 12

Point of contact: Mrs. Paula Rohlf, Code 2004, 767-3427

Safety Office

(Code 2010)

Basic Responsibilities

The Safety Office administers the Laboratory's safety and occupational health programs except in the fields of microwave and radiological safety. Its responsibilities include inspection, training, and education. It also conducts accident investigations, prepares directives, provides accident prevention information, directs the activities of safety representatives and committees, reviews hazardous experiments, and guides management in matters of safety.

Key Personnel

Name	Title
Mr. H.C. Kennedy, Jr.	Head, Safety Office



Mr. H.C. Kennedy, Jr.

Personnel

Full-time civilian: 7

Point of contact: H.C. Kennedy, Jr., Code 2010, 767-2249

*Acting

¹Patent Counsel to be transferred to Code 1200 July/August 1986.

Administrative Services Office (Code 2020)

Basic Responsibilities

The Administrative Services Office plans, directs, and coordinates the following administrative services for the Laboratory: records and correspondence management; mail handling and messenger service; managing the purchase, acquisition, issuance, and withdrawal of filing equipment; managing the Forms Management Program, Paperwork Reduction Program, Reports Management Program, Correspondence Training Program, and Parking Facilities Management Program; coordinating and publishing the NRL Code Directory; and coordinating staffing plans for the Technical Services Directorate.

Key Personnel

Name	Title
Mrs. L.V. Dabney	Head, Administrative Services Office
Mrs. M. Bozzi	Administrative Officer
Ms. L.T. Warder	Head, Records and Correspondence Management Branch
Mr. C.D. Moultrie	Head, Mail and Messenger Branch



Mrs. L.V. Dabney

Personnel

Full-time civilian: 28

Point of contact: Mrs. M. Bozzi, Code 2020.2, 767-3858

Management Information Systems Staff (Code 2030)

Basic Responsibilities

The Management Information Systems Staff has dual responsibilities: conducting administrative data processing for the Laboratory, and designing, implementing, and controlling the Laboratory Management Information System (MIS) and its data bases. The Staff Head participates directly with the Commanding Officer, the Director of Research, and the Director of Technical Services, in all policy matters pertaining to MIS and business data processing.

Key Personnel

Name	Title
Mr. R.L. Guest	Head, Mgt. Info. Sys. Staff
Mrs. M. Bozzi	Administrative Officer
Mrs. B. Hildreth	Head, Systems Development Section
Mr. W.L. Gollaher	Head, Applications Systems Support
Mrs. L. Johnson	Head, Operations Section

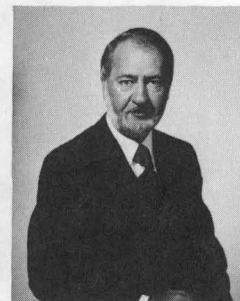

Mr. R.L. Guest

Personnel

Full-time civilian: 20

Point of contact: Phyllis Thompson, Code 2030, 767-2030

Engineering Services Division

- MECHANICAL ENGINEERING AND MANUFACTURING
- ELECTRONIC ENGINEERING AND FABRICATION
- QUALITY ASSURANCE
- COMPUTER-AIDED DESIGN/COMPUTER-AIDED MANUFACTURING

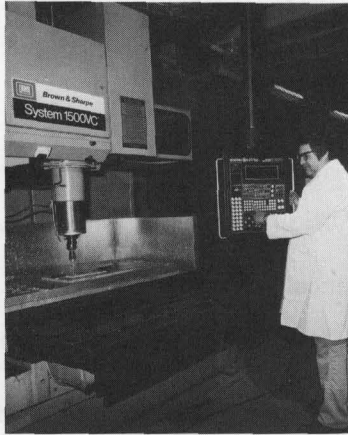

Machinist Making a Base Plate Regulator/ Modulator on the Machining Center

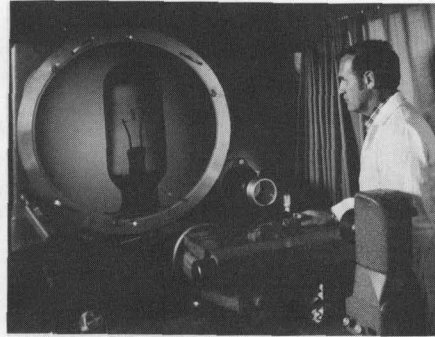

Quality Assurance Specialist Measuring Inside Diameter of a Gear on an XYZ Coordinate Measuring Machine

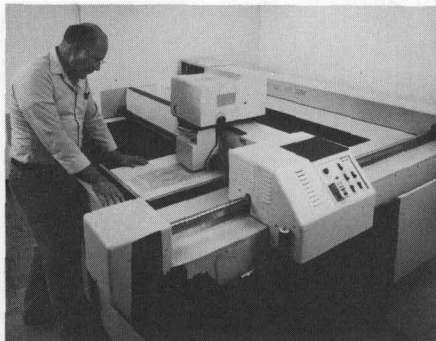

Electronic Technician Operating a Gerber Photo Plotter



Craftsmen Removing a Fiberglass Lamination from a Mold in the Plastics Shop

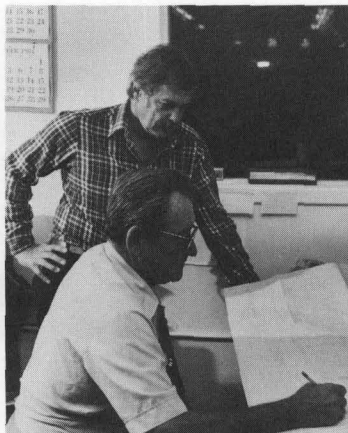

Shop Planners Estimating and Scheduling Jobs

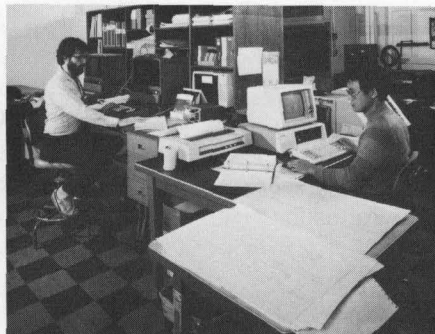

Electronic Engineers Working on Microcomputer Designs



LCDR M.L. Crouch, USN

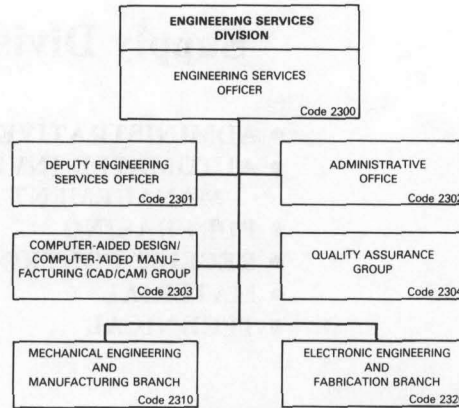

Basic Responsibilities

The Engineering Services Division provides the engineering, design, fabrication, assembly, and test of experimental research equipment in support of the Laboratory's research efforts.

Complete services covering the fields of mechanical and electronic engineering, fabrication, and manufacturing are provided and are supported by an in-house Quality Assurance Group. Emphasis is placed on quick reaction and flexibility to meet the needs of the Laboratory's research programs.

Mechanical support covers project engineering, computer-aided mechanical design and drafting, thermal and structural analysis, cost analysis, and environmental testing; it also includes shops for conventional machining or 4-axis numerical control manufacturing, sheet metal work, welding, plating, casting, plastic fabrication, engineering, and silk screen artwork.

Electronic support covers project engineering, digital and analog circuit design, microprocessor/microcomputer-based systems design (including programming), a computer-aided printed circuit board design (REDAC and Computervision), printed circuit board fabrication, electronic assembly and testing, and cable fabrication.

Key Personnel

Name	Title
LCDR M.L. Crouch, USN	Engineering Services Officer
Mrs. M. Hudson ¹	Administrative Officer
Mr. M.A. Shimkus	Deputy Engineering Services Officer
Mr. R. D'Arconte	Computer-Aided Design/Computer-Aid Manufacturing Group
Mr. Q.A. Blush	Quality Assurance Group
Mr. R.I. Perlut	Head, Mechanical Engineering and Manufacturing Branch
Mr. A.G. Pezzulich	Head, Electronic Engineering and Fabrication Branch

Personnel

Full-time civilian: 177

Military: 1

Point of contact: Mr. Michael Shimkus, Code 2301, 767-6057

¹Mrs. J. Ford effective 4/13/86.

Supply Division

- ADMINISTRATIVE SERVICES
- AUTOMATED INVENTORY MANAGEMENT SYSTEM
- PURCHASING
- RECEIPT CONTROL
- MATERIAL
- TECHNICAL



Material Issue



Receipt Control



Purchasing/Requisition Control



Administrative Office



Automatic Inventory

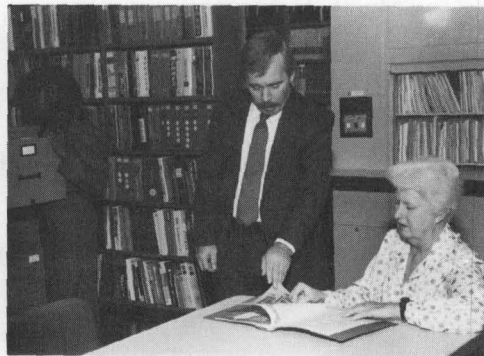

Technical Branch



LCDR T. Lippert, USN

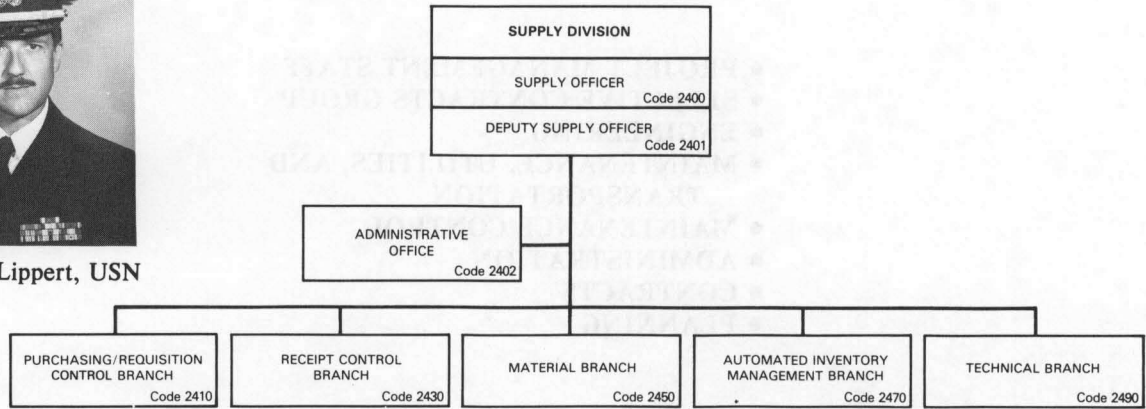

Basic Responsibilities

The Supply Division provides logistical functions to the Laboratory and its field activities, including the operation of supply issue stores; procurement of equipment, material, and contractual services; receipt, inspection, and delivery of material and equipment; packing, shipping, and traffic management; and disposal of excess and unusable property. In addition, the Division offers technical services to the research directorates in the development of specifications for a complete procurement package and guidance in the performance stages of contractual services.

During FY 1985, the Supply Division processed 41,000 purchasing actions, which totaled approximately \$45,000,000. Inventory in the seven retail stores and bulk warehouse averaged \$942,960 and 7,915 line items.

Key Personnel

Name	Title
LCDR T.R. Lippert, SC, USN	Supply Officer
Mr. S. Georgeadis ¹	Deputy Supply Officer
Mrs. C. Hartman	Head, Administrative Office
Mr. W.R. Waynes	Head, Purchasing/Requisition Control Branch
Mr. J.J. Dupcavitch	Head, Receipt Control Branch
Mr. A.W. Medley, Sr. ²	Head, Material Branch
Mrs. E.I. Woodland	Head, Automated Inventory Management Branch
Mr. B.A. Copson	Head, Technical Branch

Personnel

Full-time civilian: 137

Military: 1

Point of contact: Mrs. C. Hartman, Code 2402, 767-3781

¹ Retiring effective 7/11/86

² Retiring effective 5/30/86

Public Works Division

- PROJECT MANAGEMENT STAFF
- SELECTIVE CONTRACTS GROUP
- ENGINEERING
- MAINTENANCE, UTILITIES, AND TRANSPORTATION
- MAINTENANCE CONTROL
- ADMINISTRATION
- CONTRACTS
- PLANNING



*Modifying Computer Room
Floor Tiles*

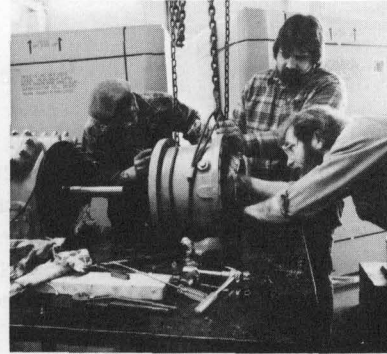

Repairing a Compressor



Woodworking Shop

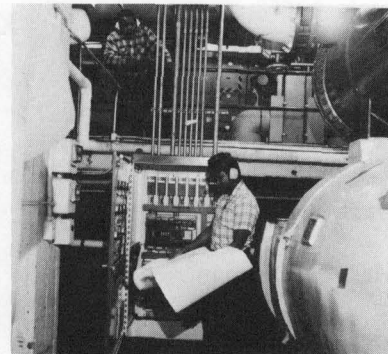

*Checking Operation of the
Chilled Water Plant*



Providing Engineering Support



CDR J.P. Collins,
CEC, USN

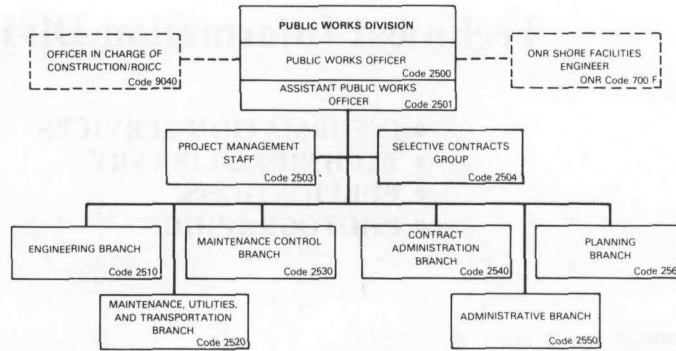

Basic Responsibilities

The Public Works Division is responsible for the physical plant of NRL. This includes: (a) responsibility for the design, construction, maintenance, and repair of public works and utilities; (b) responsibility for the operation of these public works and utilities in accordance with the technical standards of the Naval Facilities Engineering Command; and (c) supporting the scientific program of the Laboratory by the construction, repair, and alteration of experimental and test equipment. In addition, the Division obtains required approvals for work for which the Division is responsible from the Chesapeake Division of the Naval Facilities Engineering Command, the Office of Naval Research, the Secretary of the Navy, and other authorities as appropriate.

The Public Works Division also supports the Office of Naval Research for Facilities Coordination and supports the Resident Officer in Charge of Construction on all Naval Facilities Engineering Command and certain research and development contracts at NRL.

Key Personnel

Name	Title
CDR J.P. Collins, ¹ CEC, USN	Public Works Officer/Officer in Charge of Construction/ONR Shore Facilities Engineer
LT J. Dell, USN	Assistant Public Works Officer
Mr. T. Graves	Project Management Staff
Mr. G. Kitchin	Selective Contracts Group
Mr. J. Urritia	Head, Engineering Branch
Mr. C.B. Conner	Head, Maintenance, Utilities, & Transportation Branch
Mr. J.P. Kosker	Head, Maintenance Control Branch
Vacancy	Head, Contracts Administration Branch
Mrs. A. Coats	Head, Administrative Branch
Mr. D. Price	Head, Planning Branch

Personnel

Full-time civilian: 336

Military: 2

Point of contact: Mrs. A. Coats, Code 2550, 767-2168

¹CDR Collins transferred 5/23/86. New PWO CDR T.R. Rampe

Technical Information Division

- INFORMATION SERVICES
- TECHNICAL LIBRARY
- PUBLICATIONS
- PHOTOGRAPHIC

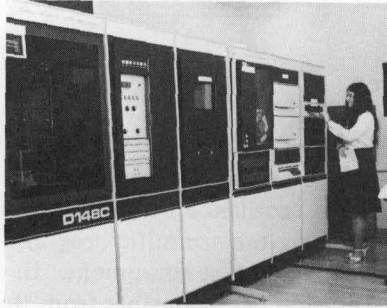

DICOMED Computer

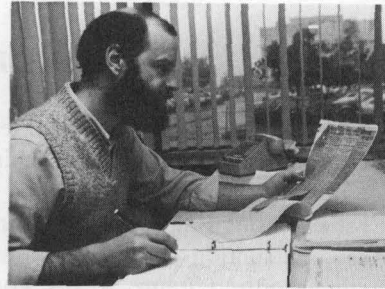

Archiving Material of Historic Significance



Service Desk

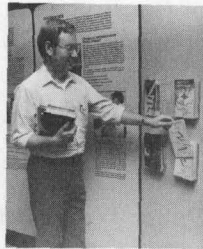

Exhibits

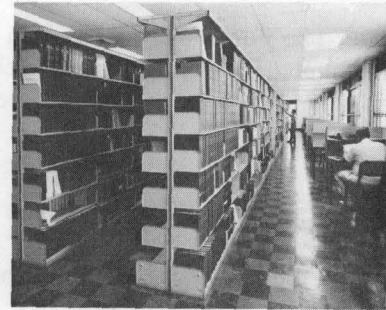

Library



Presentation Support

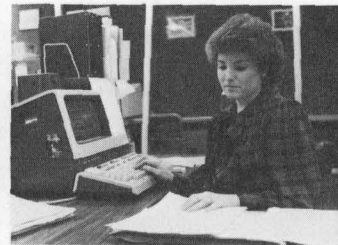

Computerized Technical Composition



Public Affairs and Internal Communication



Graphic Services



Mr. P. Imhof

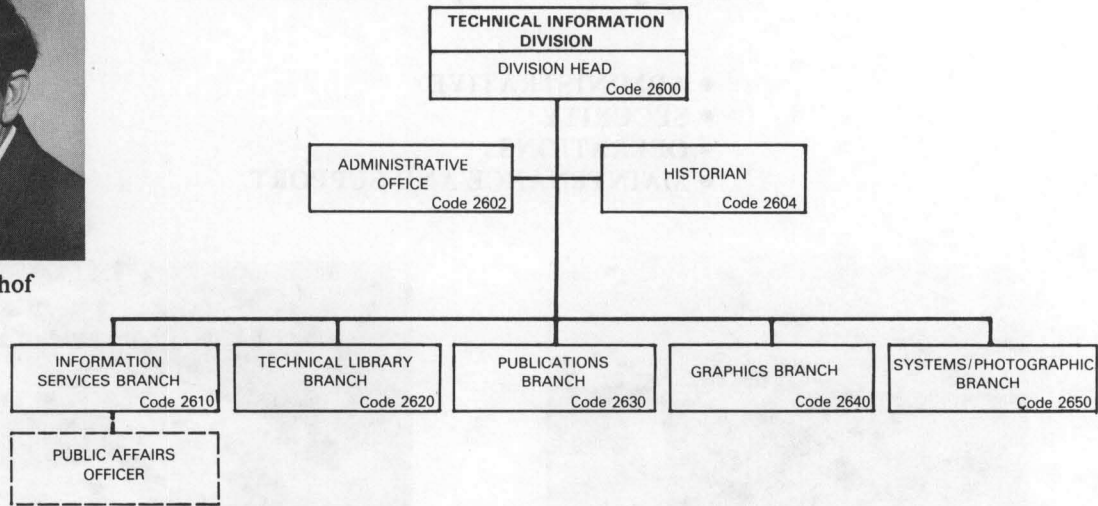

Basic Responsibilities

The Technical Information Division provides centralized support to the Laboratory, and sometimes the Office of Naval Research, in the collection, retention, processing, publishing, presenting, and distribution of information in many forms to many audiences.

The following are the specific ways the Technical Information Division supports the Laboratory: by providing a full range of Library services, editing and publishing of periodicals and reports, specialized scientific and general photographic services, illustration and visual aid services, DICOMED support, scientific composition, special projects graphics, auditorium and meeting support, collection and maintenance of historical data, exhibits its construction and showing, video data gathering services, management of public and internal information programs (publishing Lababstracts, NRL's biweekly newspaper), and conducting Freedom of Information Act activities as required by law.

Key Personnel

Name	Title
Mr. P. Imhof	Head, Technical Information Division
Mrs. C. Uffelman	Administrative Officer
Vacant ¹	Historian
Mr. J.W. Gately, Jr.	Head, Information Services Branch and Public Affairs Officer*
Vacant	Head, Technical Library Branch
Mr. T. Calderwood	Head, Publications Branch
Ms. L. Jackson	Head, Graphics Branch
Mr. J. Lucas	Head, Systems/Photographic Branch

Personnel

Full-time civilian: 111

Point of contact: Mrs. C. Uffelman, Code 2602, 767-3370

*Additional Duty

¹Dr. D. Van Keuren effective 6/86

Chesapeake Bay Detachment

- ADMINISTRATIVE
- SECURITY
- OPERATIONS
- MAINTENANCE AND SUPPORT



45-ft Workboat

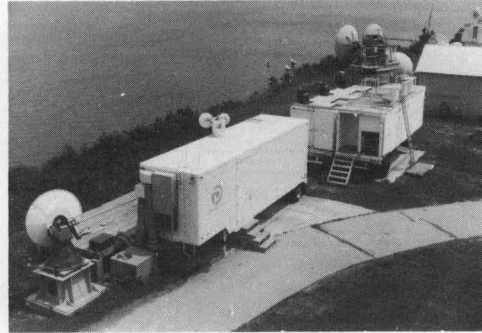

Tactical Electronic Warfare Vans

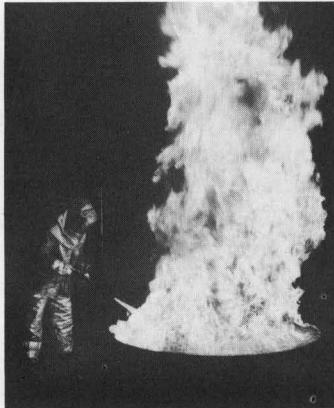

Fire Testing Facility



Tilghman Island Test Facility

Research Division Representatives

Optical Sciences Division

Mr. C. Gott, Field Experiments

Radar Division

Mr. J. Ahearn, Radar Division

Mr. M. Siegert, Target Characteristics Branch

Mr. J. Ward, Search Radar Branch

Mr. J.T. Ferrell, Radar Techniques Branch

Tactical Electronic Warfare Division

Mr. V. J. Kutsch, Tactical Electronic Warfare Division

Chemistry Division

Dr. H. W. Carhart, Fire Test Facility

Condensed Matter and Radiation Sciences Division

Mr. Alan J. Zakraysek, Impact Vulnerability Staff

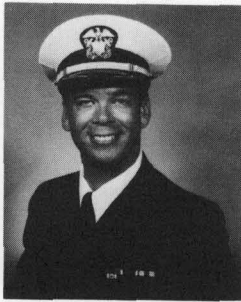

LT J.P. Dell

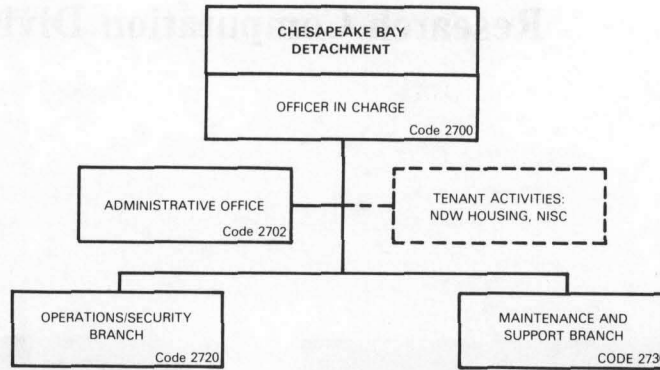

Basic Responsibilities

The Chesapeake Bay Detachment operates and maintains an independent military facility for NRL research. It has a variety of shops, plant facilities, and specialized equipment used in support of the variety of NRL and tenant research and development projects which can best be carried out there.

The Physical Plant

Located in a relatively clear area away from congestion and industrial interference, the main site, at Randle Cliff, Maryland, covers 68.1 hectares (167.9 acres) and has 183 structures of various sizes and types of construction, six of which are major laboratory buildings. There is over 86 m (282 ft) of usable dock space with a controlling water depth of 2.1 m (7 ft), located 3.2 km (2 mi) north of the main site in Chesapeake Beach. Off-site facilities include the Tilghman Island Facility, located directly across the Bay from CBD at a range of 16.25 km (10 mi).

Research watercraft available at CBD include 17-m (56-ft) landing craft, one jack-up-barge, one 14-m (45-ft) support craft, and one 11-m (36-ft) patrol boat. These are used in support of research projects and for transportation to off-site facilities.

Key Personnel

Name	Title
LT J.P. Dell, USN*	Officer in Charge
Mrs. M.J. Hamor	Administrative Officer
Mr. L. Phelps	Operations/Security Officer
Mr. J.G. Grigg ¹	Maintenance Support Officer

Personnel

Full-time civilian: 25

Military: 1

Point of contact: Mrs. M.J. Hamor, Code 2702, (301) 257-4004

*Acting

¹Effective 11/3/85 Mr. T.N. Erwin

Research Computation Division

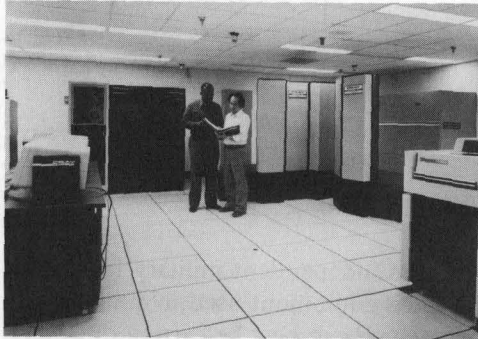

Cray XMP-12 Central Processing Unit



Disk Storage for the Cray Computer

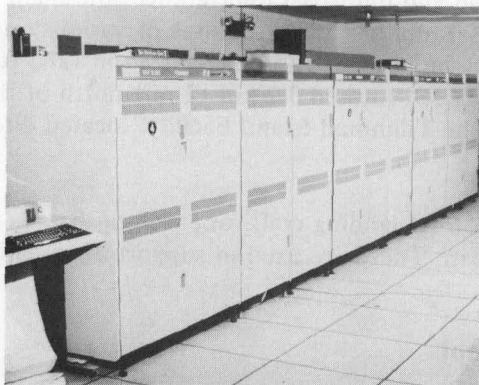

These Three VAX 11/785s Provide Access to the Cray Computer

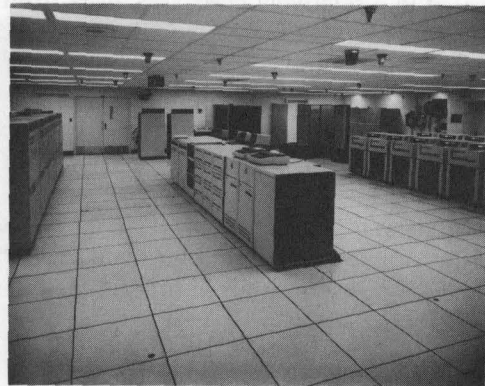

Front-end VAX Cluster

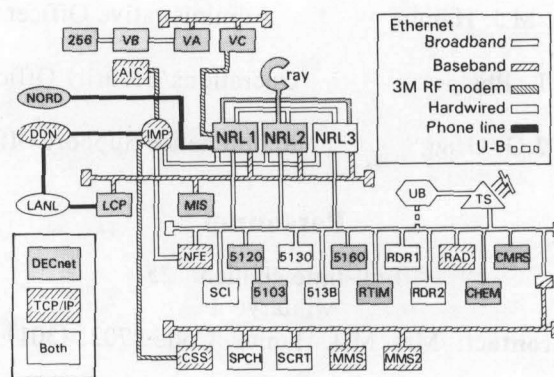

NRL Network

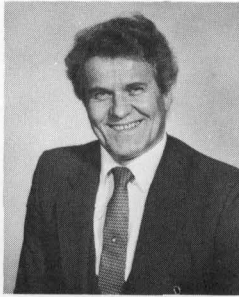

Mr. Rudi F. Saenger

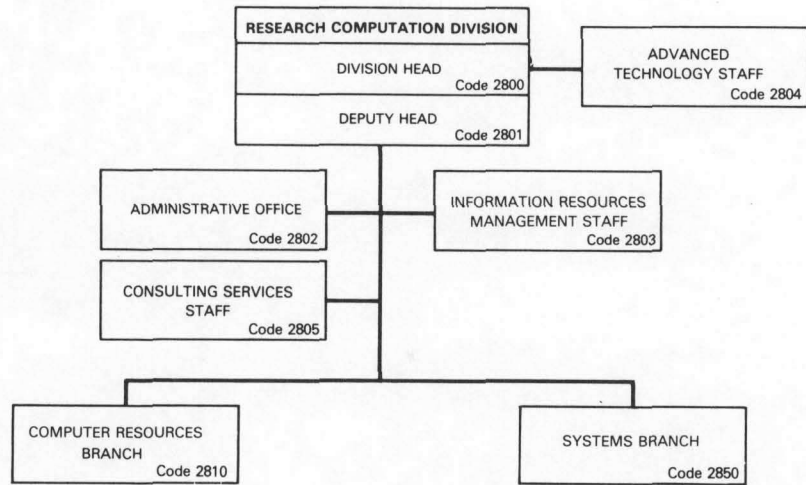

Basic Responsibilities

The Research Computation Division (RCD) provides a wide variety of concurrent computer services to over 1200 scientists and engineers, both at NRL and at remote locations throughout the United States. These services include high volume, time-shared, local and remote batch; active graphics; and telecommunications processing.

The RCD manages and operates NRL's Central Computer Facility (CCF), a totally integrated computer system consisting of a Cray X/MP with its associated support equipment, and a highspeed network of Digital Equipment Corporation VAX 11/785 computer systems, that facilitate communications between the user community and the CCF. The Cray X/MP, a class VI computer, is the fastest computer manufactured in the United States. Through use of local area networking (NICENET) and a world-wide networking system (Defense Data Network), both local and remote users access the CCF through their host computers (including personal workstations) or by terminals.

The RCD also provides appropriate ADP technical logistic support services for NRL; identifies ADP requirements and may secure and administer contractual ADP support services; and supports the Navy Laboratory Computing Committee and the Navy Laboratory Computer Network. The Head of the RCD, by additional duty assignment, is the ONR Special Assistant for ADP Coordination.

Key Personnel

Name	Title
Mr. Rudi F. Saenger	Head, Research Computation Division
Ms. D.E. Gossett	Deputy Head
Ms. B.M. Thomas	Administrative Officer
Mr. J.B. Smith	Head, Information Resources Management Staff
Mr. Rudi F. Saenger*	Head, Advanced Technology Staff
Mr. Rudi F. Saenger*	Head, Consulting Services Staff
Mr. George E. Perez	Head, Computer Resources Branch
Mr. Harvey K. Brock	Head, Systems Branch

Personnel

Full-time civilian: 44

Point of contact: Mr. Rudi F. Saenger, Code 2800, 767-2751

*Acting



General Science and Technology Directorate

The Navy's operational effectiveness depends on its ability to keep pace with today's rapidly developing technologies. This Directorate contributes to this requirement by maintaining capabilities in, and cognizance of, a wide variety of state-of-the-art scientific research areas. These include modern computational physics; astrophysics; atmospheric, ionospheric, space, and plasma sciences; and pulsed power technologies. Areas of strong emphasis include solar physics, wide-spectrum astronomy, fluid mechanics and hydrodynamics, modeling of atmospheric and ionospheric processes, nuclear weapons effect simulation, high-energy density storage devices, and controlled energy programs.

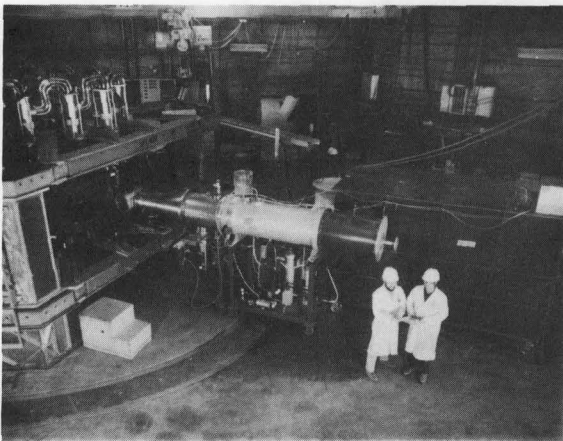

Modified Betatron



*NRL Payload Specialist in Orbit
on Spacelab-2 Mission*

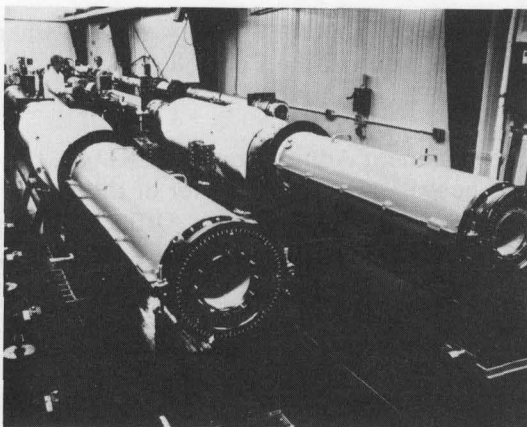

Pharos III Glass Laser System

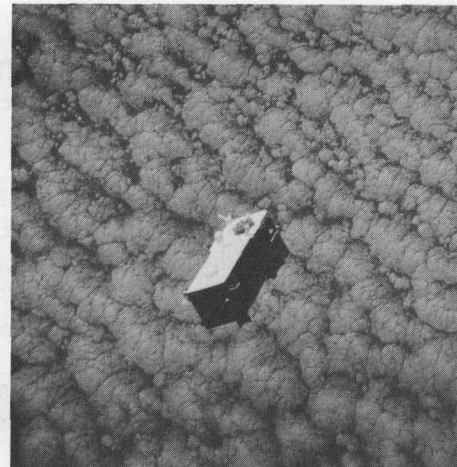

*SPARTAN-I X-ray Satellite After
Release from Shuttle*

Associate Director of Research for General Science and Technology



Dr. William R. Ellis

Dr. Ellis [REDACTED] He attended Clemson University where he obtained his undergraduate degree in physics. He then attended Princeton University where he obtained an M.S. degree in 1965 and, in 1967, one of the first doctorates in the emerging field of plasma propulsion for spacecraft.

The next three years found him at the Culham Laboratory for Plasma Physics and Fusion Research in England, where he headed an experimental group investigating toroidal discharge physics problems in plasma confinement. This marked the beginning of his long involvement with the fusion program.

In 1970 he accepted a position with the Los Alamos Scientific Laboratory in New Mexico where he became Associate Group Leader for the Scyllac experimental group in the Controlled Thermonuclear Research Division.

In 1976, Dr. Ellis joined the Energy Research and Development Administration (ERDA), the predecessor agency of the Department of Energy. In 1979, he was appointed Director of the Department's Mirror Confinement Systems Division in the Office of Fusion Energy, Office of Energy Research, where he was responsible for programs to develop fusion power reactors based on the magnetic mirror confinement concept.

In October 1983, Dr. Ellis was appointed Associate Director of Research for General Science and Technology at the Naval Research Laboratory.

Dr. Ellis has published over 100 papers and reports in the areas of experimental and theoretical plasma physics and fusion research. He has been active in several scientific and professional societies and served on the Executive Committee of the American Physics Society, Division of Plasma Physics. He has served on numerous panels, including the Department of Energy's Fusion Coordinating Committee, the USA/USSR Joint Fusion Power Coordinating Committee, program committees for international plasma physics conferences, and has chaired many technical review groups.

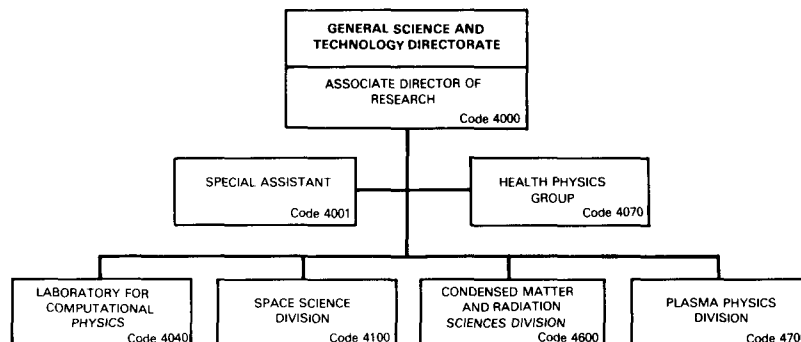

Key Personnel*

Name	Title	Code
Dr. W.R. Ellis	Associate Director of Research for General Science and Technology	4000
Mrs. L.T. McDonald	Special Assistant	4001
Dr. J.P. Boris	Chief Scientist, Laboratory for Computational Physics	4040
Mr. J.N. Stone*	Head, Health Physics Group	4070
Dr. H. Gursky	Superintendent, Space Science Division	4100
Dr. D.J. Nagel*	Superintendent, Condensed Matter and Radiation Sciences Division	4600
Dr. S. Ossakow	Superintendent, Plasma Physics Division	4700

Point of contact: Mrs. L.T. McDonald, Code 4001, 767-1002

*Effective 1 January 1986, the Condensed Matter and Radiation Sciences Division (Code 6600) and the Health Physics Group (Code 6070) became part of the General Science and Technology Directorate. Their new codes are Code 4600 and Code 4070, respectively.

Health Physics Group*

(Code 4070)

Basic Responsibilities

The Health Physics Group provides a Laboratory-wide protection program for the possession and use of all sources of ionizing and microwave radiation. The staff performs technical monitoring, evaluation, and research to assure that NRL radiological and microwave operations are safe and in compliance with federal, state, and Navy regulations. It provides employees with training, instructions, instruments, assistance, and controls needed to carry out their radiological and microwave safety responsibilities.



Mr. J.N. Stone

Key Personnel

Name	Title
Mr. J.N. Stone	Head, Health Physics Group
Mr. T.L. Johnson	Head, Research & Technical Support Section
Mr. R.B. Luersen	Head, Survey & Analysis Section

Personnel

Full-time civilian: 13

Point of contact: J.N. Stone, Code 6070, 767-2232

*Effective 1/1/86

Space Science Division

Research Activity Areas

Atmospheric Physics

Boundary layer and electro-optics meteorology; aerosol and cloud atmospheric electricity

X-ray Astronomy

X-ray observation, analysis of space astronomical sources

Radio and Infrared Astronomy

Galactic/extragalactic radio/IR astronomy; VLBI interferometry, middle atmosphere microwave sensing

Ultraviolet Measurements

Ultraviolet astronomy; sensing/modeling of atmos/ionospheres

Gamma and Cosmic Ray Astrophysics

Gamma-ray astrophysics; solar-flare gamma-rays; space cosmic ray particle environment

Solar Physics

Solar ultraviolet spectroscopy, especially on shuttle/Spacelab

Solar-Terrestrial Relationships

Solar X-ray/EUV plasma diagnostics; coronal effects at earth

Ionospheric Effects

Ionospheric modification; ionospheric propagation, modeling

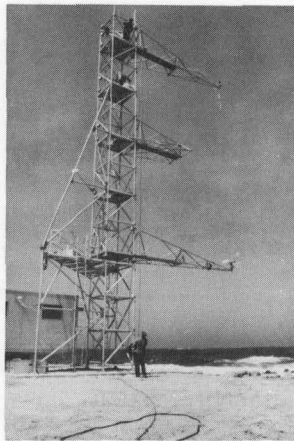

*Marine Boundary Layer Experiment
at San Nicolas Island, CA*

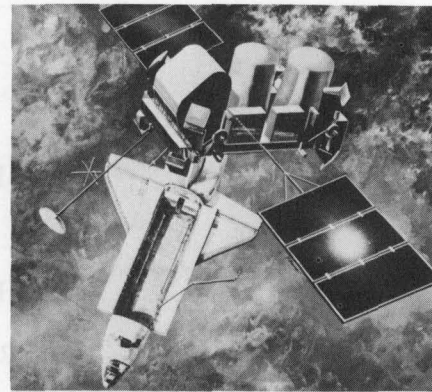

*Gamma Ray Observatory Mission Incorporating
NRL Scintillation Spectrometer Experiment
(OSSE)*

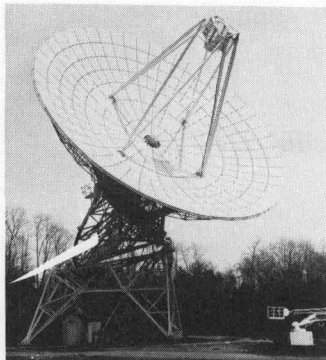

*Radio Telescope at
Maryland Point, MD*

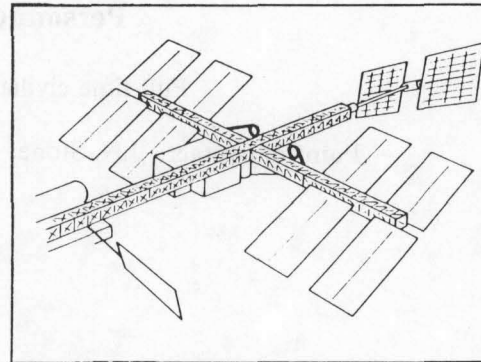

*NRL X-ray Large Array Concept
for the NASA Space Station*

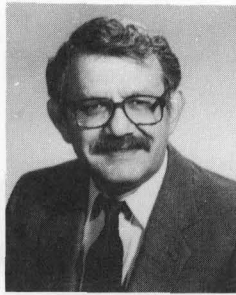

Dr. H. Gursky

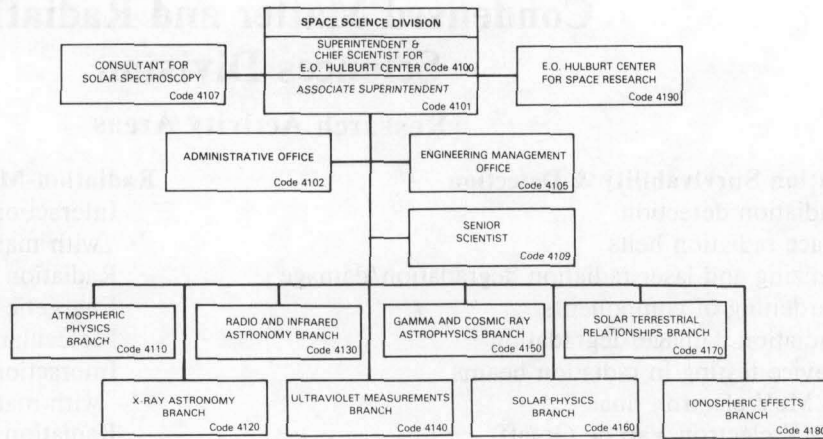

Basic Responsibilities

The Space Science Division conducts research in the fields of astronomy and astrophysics, solar-terrestrial physics, and atmospheric science. Satellites, rockets, and ground-based facilities are used to obtain information on radiation from the sun and celestial sources, and to study the behavior of the ionosphere and high atmosphere. Radio telescopes are used for astronomical observations and atmospheric sensing. Research results are of importance to radio communications, to utilization of the space environment, to weather prediction, and to fundamental understanding of natural radiation and geophysical phenomena. The Superintendent also acts as Chief Scientist of the E.O. Hulburt Center for Space Research, created to provide research opportunities in space science to appointees from universities.

Key Personnel

Name	Title
Dr. H. Gursky	Superintendent
Dr. P. Mange	Associate Superintendent
Mrs. C.J. Marks	Administrative Officer
Vacant	Engineering Management Officer
Dr. R. Tousey	Consultant (Emeritus)
Dr. H. Gursky†	Chief Scientist, E. O. Hulburt Center for Space Research
Dr. H. Friedman	Chief Scientist (Emeritus) E. O. Hulburt Center for Space Research
Dr. G. Carruthers	Senior Astrophysicist
Dr. L. Ruhnke	Head, Atmospheric Physics Branch
Mr. G.G. Fritz	Head, X-Ray Astronomy Branch
Dr. K.J. Johnston	Head, Radio & Infrared Astronomy Branch
Dr. R.R. Meier	Head, Ultraviolet Measurements Branch
Dr. J.D. Kurfess	Head, Gamma and Cosmic Ray Astrophysics Branch
Dr. G.E. Brueckner	Head, Solar Physics Branch
Dr. G.A. Doschek	Head, Solar Terrestrial Relationships Branch
Dr. J.M. Goodman	Head, Ionospheric Effects Branch

Personnel

Full-time civilian: 131

Point of contact: Mrs. Carolyn J. Marks, Code 4102, 767-3631

†Additional duty

Condensed Matter and Radiation Sciences Division

Research Activity Areas

Radiation Survivability & Detection

- Radiation detection
- Space radiation belts
- Ionizing and laser radiation degradation/damage
- Hardening of components
- Radiation damage/degradation
- Device testing in radiation beams
- 60 MeV electron linac
- 2 MV electron Van de Graaff
- Cobalt-60 radiation source

Metal Physics

- Electronic and transport properties
- Magnetic/materials
- Multilayer structures
- Thin film science
- Superconductivity
- Nonlinear dynamics

Condensed Matter Physics

- X-ray sources, optics, and detectors
- X-ray analysis of materials
- Plasma spectroscopy
- Synchrotron radiation applications
- Phase transformations
- X-ray lithography
- Radiation effects in microelectronics
- Condensed matter theory

Radiation-Matter Interactions

- Interaction of particle beams with materials
- Radiation transport calculations
- Energetic radiation applications
- Molecular collisions
- Interaction of intense EM radiation with materials
- Radiation curing of polymers
- Hypervelocity impact

Materials Modification and Analysis

- Surface analysis by ion beam techniques
- Radiation effects from high-energy charged-particle beams
- Crystal studies by channeling techniques
- Modification of surfaces by ion implantation
- Sputtering by high-energy ions
- Theory of ion-solid interactions
- 5-MV Van de Graaff
- Two 200-kV ion implantation systems

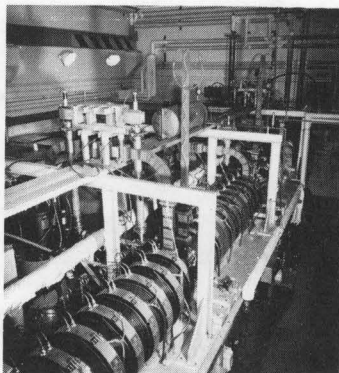

Linac

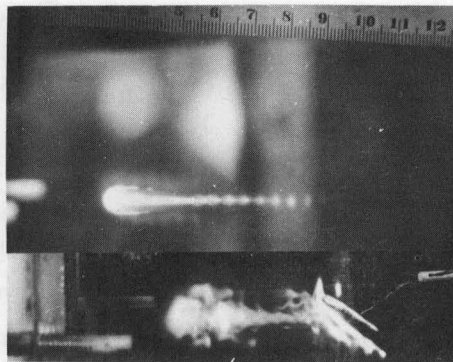

Plasma Generated by 8mm Gyrotron Radiation



Ion Beam Implanter

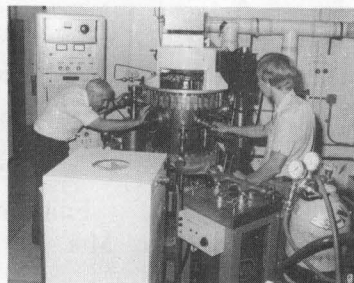

Sputtering Facility

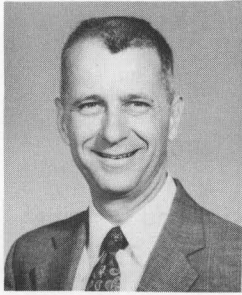

Dr. D.J. Nagel

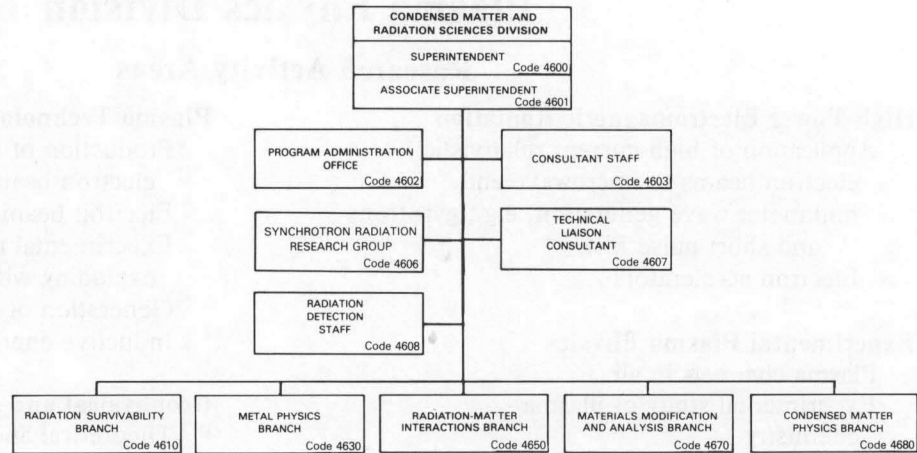

Basic Responsibilities

The Condensed Matter and Radiation Sciences Division conducts a broad program of basic and applied research on the fundamental properties of materials and on the interactions of various types of radiation with matter. Physical properties of matter, including pure metals, alloys, crystals, semiconductors, superconductors, magnetic materials, lower dimensional materials, liquids, and plasmas, are investigated theoretically and experimentally as well as by various radiation probes. Damage produced by radiation, ranging from laser and x-ray beams through charged and neutral particle beams in the megavolt region, is studied. Techniques to utilize radiation for beneficial modification of materials are also developed. Radiations of military significance are studied and simulated in the laboratory by various radiation facilities maintained and operated by the Division primarily for DoD users.

Key Personnel

Name	Title
Dr. D.J. Nagel	Superintendent
Ms. B. Murphy	Head, Program Administration Office
Dr. A.W. Saenz	Consultant (Radiation Theory)
Dr. J.W. Butler	Consultant (Ion Beam Applications)
Dr. M. Kabler	Synchrotron Radiation Research Group
Mr. S.J. Babjak	Technical Liaison Consultant
Mr. J.C. Ritter	Head, Radiation Survivability and Detection Branch
Dr. D.U. Gubser	Head, Metal Physics Branch
Dr. J.B. Aviles, Jr.	Head, Radiation-Matter Interaction Branch
Dr. F.A. Smidt	Head, Materials Modification and Analysis Branch
Dr. B.M. Klein	Head, Condensed Matter Physics Branch

Personnel

Full-time civilian: 111

Point of contact: Mr. Ms. B. Murphy, Code 4602, 767-3407

Plasma Physics Division

Research Activity Areas

High-Power Electromagnetic Radiation

Application of high-current relativistic electron beams to microwave and millimeter wave generation, e.g., gyrotrons and short pulse FEL
Electron accelerators

Experimental Plasma Physics

Plasma channels in air
Experimental study of plasma chemistry
Dense Z-pinch

Laser Plasma

Laser-plasma interaction
Laser fusion
Plasma diagnostics
Large glass laser facility
Radiation physics

Plasma Radiation

Radiation transport
X-ray laser modeling
Atomic structure and processes
Radiation hydrodynamics

Advanced Beam Technologies

Modified Betatron Accelerator
Long pulse and two-stage FELs
Rebatron Accelerator
High-quality electron beams

Plasma Technology

Production of intense relativistic electron beams
Electron beam propagation and focusing
Experimental research in high-power exploding wires
Generation of intense ion beams
Inductive energy storage

Geophysical and Plasma Dynamics

Theoretical and numerical simulation of ionospheric and magnetospheric phenomena
High-altitude nuclear weapons effects on the ionosphere/magnetosphere
Solar-terrestrial relations
Ionospheric-magnetospheric coupling

Plasma Theory

Numerical simulation of high-density plasmas
Theoretical study of nonlinear plasma dynamics
Production and propagation of high-energy charged particle beams
Radiation source development

Experimental Space Plasma Physics

Rocket, satellite, and shuttle-borne natural and active experiments
Laboratory simulation of space plasma processes

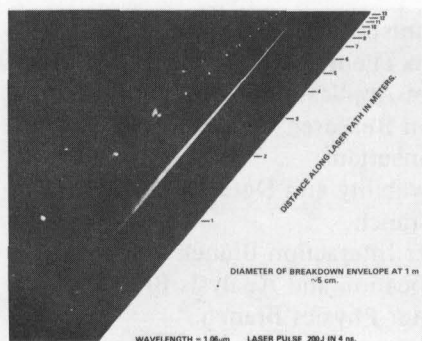

Laser-produced 10-m-Long Spark in Air for Channeling Electron Beams

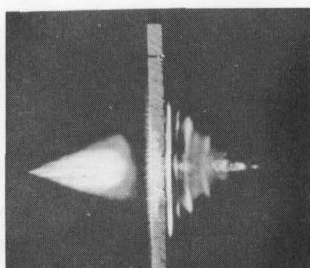

Air Breakdown Induced by High Power Microwaves from a Free Electron Laser

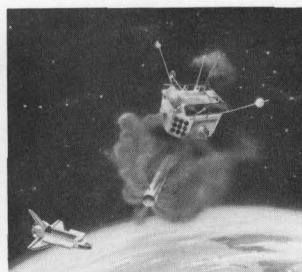

NRL Participation in NASA Chemical Release Experiments in Space

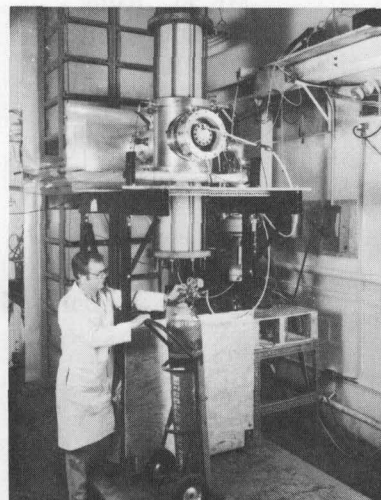

PAWN, 1-MJ Compact Inductive Storage Facility



Dr. S. Ossakow

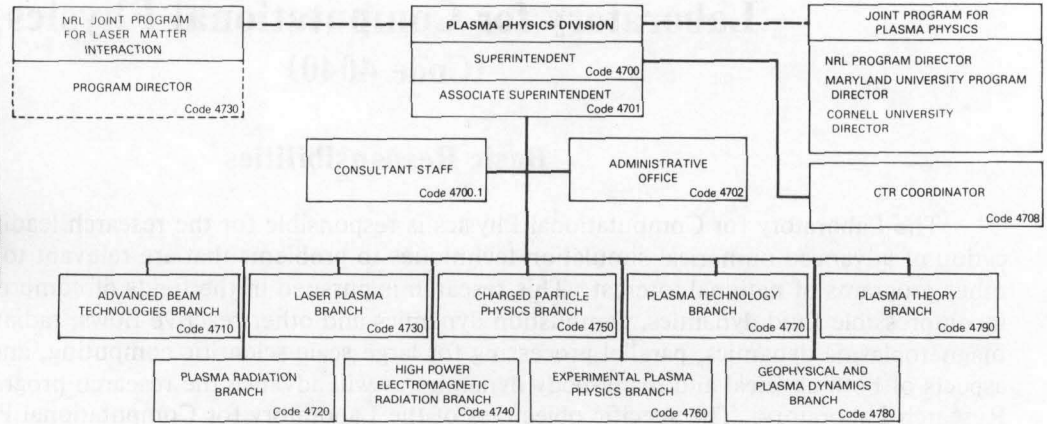

Basic Responsibilities

The Plasma Physics Division conducts a broad program in basic and applied research in plasma physics, electron and ion beams, atomic physics, pulsed power sources, and laser physics. The effort of the Division is concentrated on a few closely coordinated theoretical and experimental programs. Considerable emphasis is placed on large-scale numerical simulations related to plasma dynamics, ionospheric, magnetospheric, and atmospheric dynamics, and the effects of high-altitude nuclear weapons on the atmosphere, thermonuclear plasma confinement, atomic physics, and relativistic electron beam propagation. Areas of experimental interest include: relativistic electron beams, laser-matter interaction, thermonuclear fusion, electromagnetic wave generation, the generation of intense ion beams, advanced accelerator development, inductive energy storage, and the interaction of charged particle beams with the atmosphere.

Key Personnel

Name	Title
Dr. S. Ossakow	Superintendent
Mr. I. Vitkovitsky	Associate Superintendent
Dr. W. Ali	Consultant
Dr. P. Palmadesso	Consultant
Dr. M. Friedman	Consultant
Ms. T. Mason	Administrative Officer
Dr. S. Ossakow*	Head, Space Plasma Physics and Applications Research Group
Dr. A. Robson	Coordinator, CTR Program
Dr. C. Kapetanakos	Head, Advanced Beam Technologies Branch
Dr. J. Davis	Head, Plasma Radiation Branch
Dr. S. Bodner	Head, Laser Plasma Branch
Dr. W. Manheimer	Head, High-Power Electromagnetic Radiation Branch
Dr. A. Robson	Head, Experimental Plasma Physics Branch
Dr. G. Cooperstein	Head, Plasma Technology Branch
Dr. J. Huba	Head, Geophysical and Plasma Dynamics Branch
Dr. P. Sprangle	Head, Plasma Theory Branch

Personnel

Full-time civilian: 119

Point of contact: Dr. S. Ossakow, Code 4700, 767-2723

*Acting

Laboratory for Computational Physics (Code 4040)

Basic Responsibilities

The Laboratory for Computational Physics is responsible for the research leading to and the application of advanced numerical simulation techniques to problems that are relevant to Navy, DoD, and other programs of national interest. This research is pursued in the fields of compressible and incompressible fluid dynamics, combustion dynamics and other reactive flows, radiation transport and magnetoplasma dynamics, parallel processing for large-scale scientific computing, and such other aspects of both classical and many-body dynamics as will advance the research program of the Naval Research Laboratory. The specific objectives of the Laboratory for Computational Physics are: to develop and maintain a state-of-the-art computational physics capability in fluid dynamics and related fields of physics, to perform analyses and computations on specific relevant problems using these capabilities, and to transfer this numerical technology to new and ongoing projects through cooperative programs with the research divisions and detachments at NRL and elsewhere. Areas of current interest include: studies of the hydrodynamic stability of imploding systems, solution of fluid dynamic flows that involve free surfaces for naval hydrodynamics and other applications, studies of combustion dynamics and reactive flow modeling in which convection and turbulent mixing may be important, modeling of ionospheric and heliospheric dynamics and chemistry, and pursuit of advanced numerical techniques for general application.

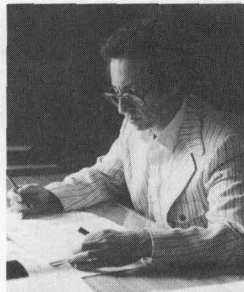

Dr. J. P. Boris

Key Personnel

Name	Title
Dr. J.P. Boris	Chief Scientist
Ms. D. Miller	Administrative Officer
Dr. D.L. Book	Senior Scientist
Dr. E.S. Oran	Senior Scientist
Mr. J.H. Gardner	Senior Scientist

Personnel

Full-time civilian: 16

Point of contact: Ms. Darlene Miller, Code 4040, 767-6581



SYSTEMS RESEARCH AND
TECHNOLOGY DIRECTORATE

Systems Research and Technology Directorate

The Systems Research and Technology Directorate performs basic research and development in support of major generic Navy systems. The emphasis is on radar systems, electronic warfare systems, and undersea warfare systems. The Directorate conducts an extensive experimental program in the field, using both ship and aircraft platforms to support the above activities. Programs in ocean engineering, environmental factors, and calibration and standards for underwater acoustic devices are pursued in support of the R&D for Navy systems.



Electronic Warfare R&D Laboratory Complex. (Near wing is artist's rendition of future Coordinated EW Simulation Laboratory.)

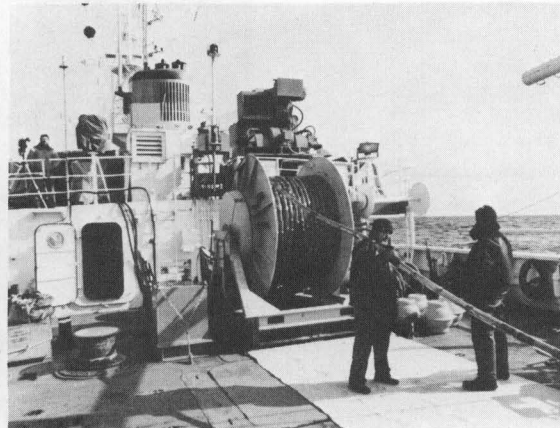

Ocean Acoustic Research

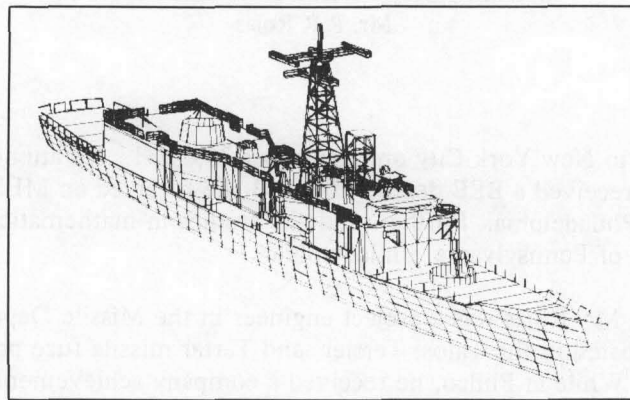

FFG-15 Cross Section Model

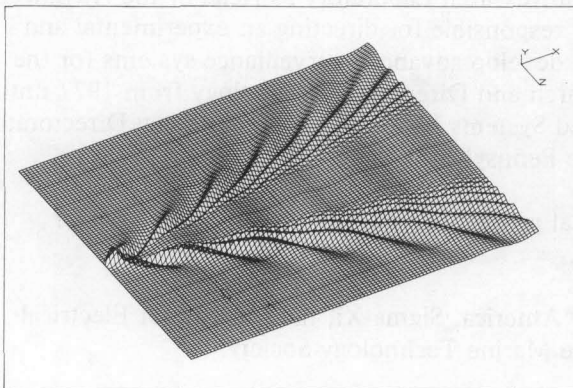

Computer-Generated Simulated Kelvin Wake

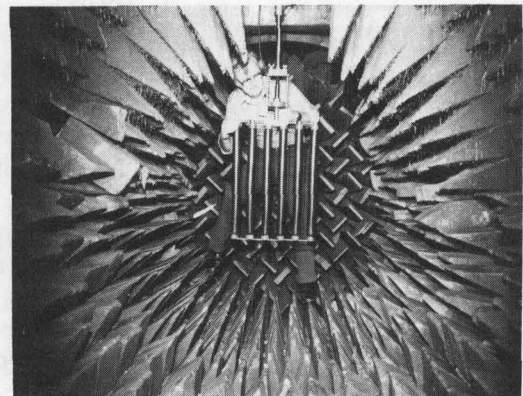

F-43 Plane Array Transducer in Drained Anechoic Tank

Associate Director of Research for Systems Research and Technology

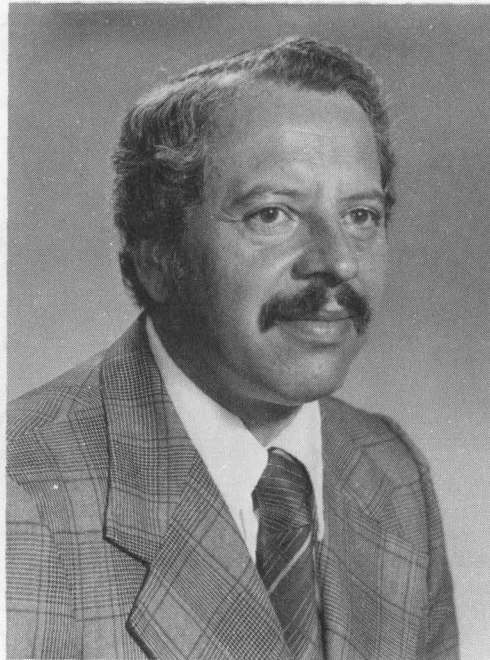

Mr. R.R. Rojas

Mr. Rojas [REDACTED]. He attended City College of New York, where in 1952, he received a BEE degree. In 1961, he received an MEE degree from Drexel Institute of Technology, Philadelphia. Further graduate studies in mathematics and engineering were pursued at the University of Pennsylvania, Philadelphia.

From 1952 to 1960, Mr. Rojas was a project engineer in the Missile Department at Philco Corporation where he participated in the Talos, Terrier, and Tartar missile fuze programs, and the Terrier missile guidance project. While at Philco, he received a company achievement award for his work on the design of specialized missile test equipment. From 1960 to 1969, he was manager of the Hydroacoustics Department at the Magnavox General Atronics Corporation. At General Atronics he was active in the area of signal processing techniques as applied to sonar, communication systems, and seismic detection systems. In 1969, he joined the Naval Research Laboratory as Head of the Advanced Undersea Surveillance Program. In his capacity he was responsible for directing an experimental and theoretical program whose purpose was to evaluate and develop advanced surveillance systems for the Navy. Mr. Rojas served as Associate Director of Research and Director of Oceanology from 1977 until 1980, when he assumed control of the newly established Systems Research and Technology Directorate. Mr. Rojas also was on the graduate teaching staff at the Pennsylvania State University.

Mr. Rojas' research interests are centered on signal processing and the physics of underwater acoustic propagation, ambient noise, and reverberation.

Mr. Rojas is a member of the Acoustic Society of America, Sigma Xi, the Institute of Electrical and Electronics Engineers, and a charter member of the Marine Technology Society.

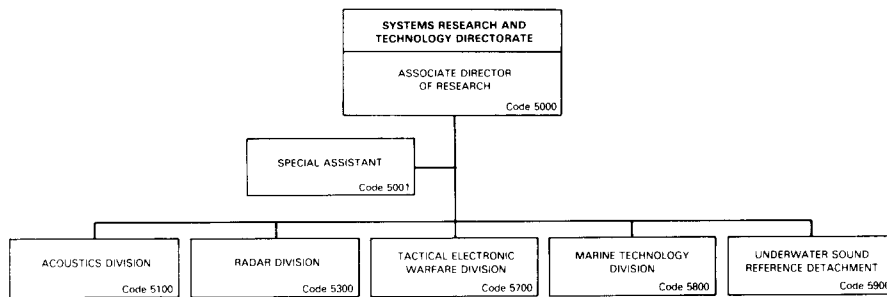

Key Personnel

Name	Title	Code
Mr. R.R. Rojas	Associate Director of Research for Systems Research and Technology	5000
Vacancy	Special Assistant	5001
Dr. D.L. Bradley	Superintendent, Acoustics Division	5100
Dr. M.I. Skolnik	Superintendent, Radar Division	5300
Dr. J.A. Montgomery	Superintendent, Tactical Electronic Warfare Division	5700
Dr. R.T. Swim	Superintendent, Marine Technology Division	5800
Dr. J.E. Blue	Superintendent, Underwater Sound Reference Detachment	5900

Point of contact: Mr. R.R. Rojas, Code 5000, 767-3294

Acoustics Division

Staff Activities, Field, and Laboratory Support

Special Programs Management
Systems studies
Systems concepts and evaluation
Engineering research and development

Research Activity Areas

Acoustic Media Characterization

Geophysical and oceanographic parameters
that influence underwater acoustics

Applied Ocean Acoustics

Airborne underwater acoustics
Bottom-limited acoustics
Arctic underwater acoustics
Propagation
Noise
Ambient noise measurements
and modeling
Spectral estimation
Signal Processing

Physical Acoustics

Reflection, diffraction,
scattering by bodies
Target strength modeling
Schlieren visualization
Fiber-optic acoustic sensors
Acoustics of coatings

Software Systems Development

Tactical computers
Tactical support software
Signal processors

Large Aperture Acoustics

Propagation, coherence, and wave-
front behavior
Large-scale spatial and temporal
integration
Array deformation
Low-frequency monostatic and
bistatic reverberation
Shallow-water acoustics
Mode analysis
Models of signal and noise fields

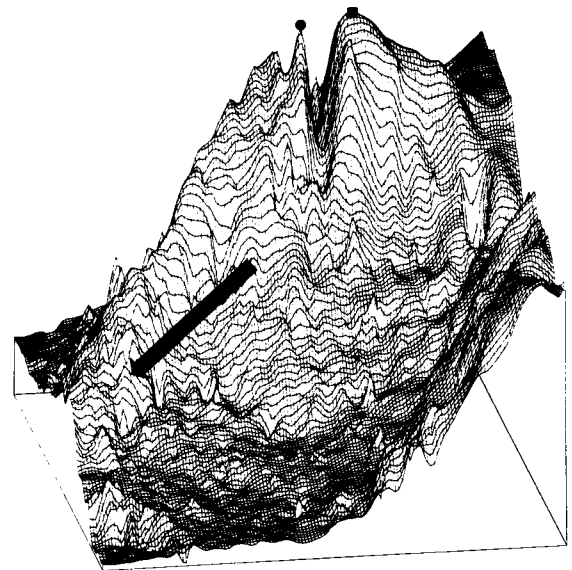
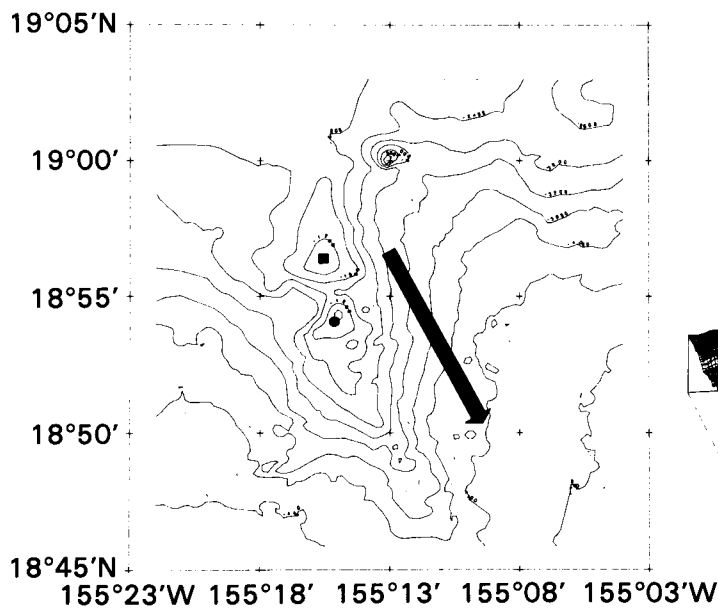

Computer-Generated Bathymetry



Dr. D.L. Bradley

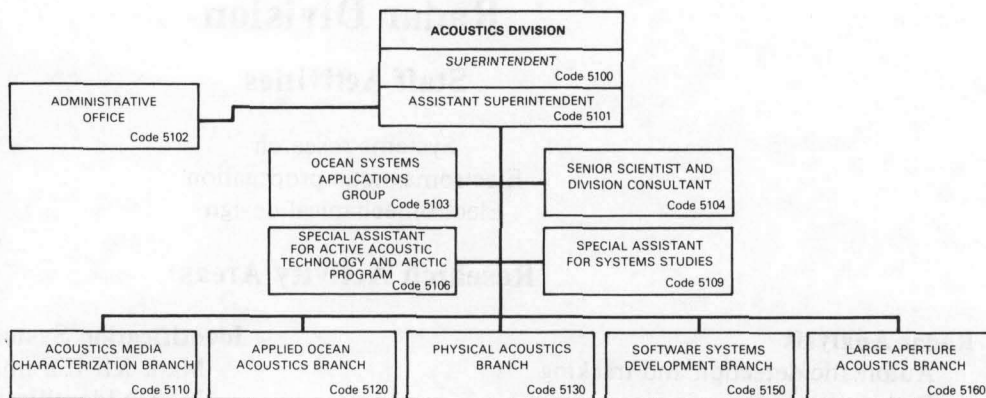

Basic Responsibilities

The Acoustics Division conducts basic and applied research in undersea acoustics. The basic research areas are: signal processing; ocean acoustics and the associated description of the ocean environment as it impacts advanced systems; and physical acoustics. The applied spectrum includes: developing and proving system concepts; signal processing for active and passive detection, tracking and classification of underwater targets; echo strength; large area assessment techniques; and development of Navy Data Processing Systems. The Division program is interactive with the ONR Contract Research Program, NORDA, and other Navy laboratories, both U.S. and foreign.

Key Personnel

Name	Title
Dr. D.L. Bradley	Superintendent
Mr. B.G. Hurdle	Assistant Superintendent
Mrs. N.J. Beauchamp	Administrative Officer
Dr. S. Hanish	Senior Scientist and Division Consultant
Mr. C.W. Votaw	Special Assistant for Artic Program
Mr. M. Potosky	Special Assistant for Systems Studies
Mr. D. Steiger	Head, Ocean Systems Applications Group
Mr. H.S. Fleming	Head, Acoustics Media Characterization Branch
Dr. O. Diachok	Head, Applied Ocean Acoustics Branch
Dr. J. Bucaro	Head, Physical Acoustics Branch
Mrs. E.E. Wald	Head, Software Systems Development Branch
Dr. E. Franchi	Head, Large Aperture Acoustics Branch

Personnel

Full-time civilian: 135

Point of contact: Dr. D.L. Bradley, Code 5100, 767-3482

Radar Division

Staff Activities

Systems research
Electromagnetic propagation
Electromechanical design

Research Activity Areas

Radar Analysis

Automatic detection and tracking
Radar signal processing
Radar systems simulations
Target signature modeling

Radar Techniques

High-frequency over-the-horizon radar
Signal analysis
Space-based radar

Search Radar

Shipboard surveillance radar
Precision tracking techniques
Air traffic control

Target Characteristics

Radar counter-countermeasures
Adaptive signal processing
Phased array radar
Target signature analysis

Identification Systems

Mark XII IFF improvements
NATO Identification System (Mk XV)
Future identification technology

Airborne Radar

Airborne early-warning radar (AEW)
Inverse synthetic aperture radar (ISAR)

Electromagnetics

Microwave antenna research
Phased array antennas
Adaptive array research

Systems Control and Research

Image processing research
Synthetic aperture radar (SAR)
processing
Multispectral image correlation
Space sensor and mission analysis

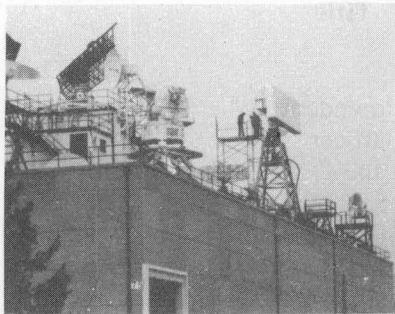

CBD Radar Test Site

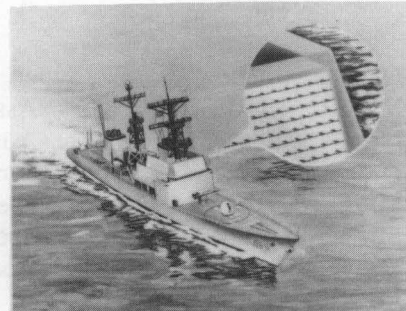

Shipboard Phased Array Radar (FASR)

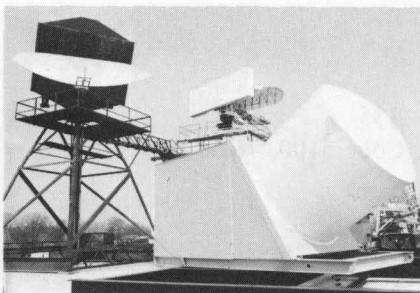

Directed Mirror Antenna Radar (DMAR) (Foreground)

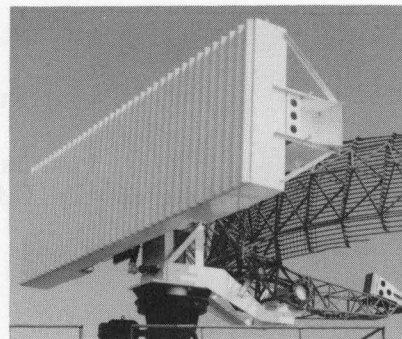

Shipboard Air Surveillance Radar (SENRAD) Antennas



Dr. M.I. Skolnik

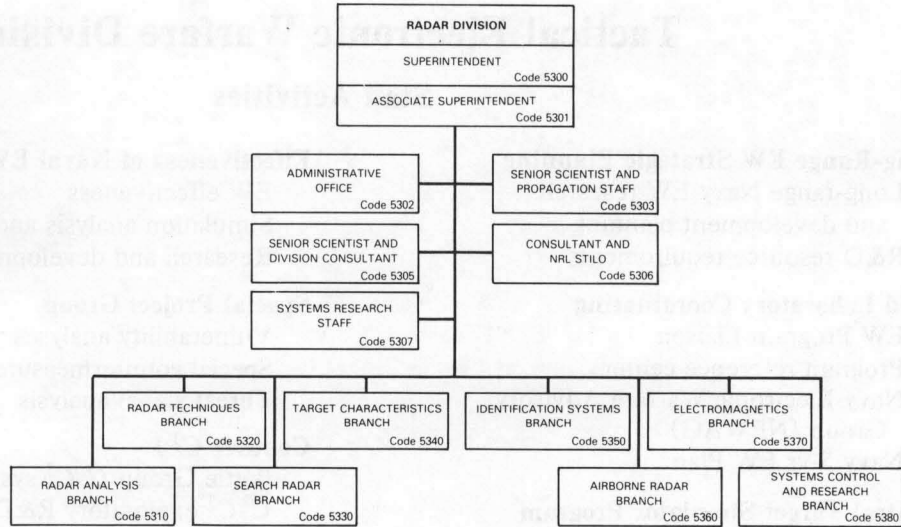

Basic Responsibilities

The Radar Division conducts research on basic physical phenomena of importance to radar and related sensors, investigates new engineering techniques applicable to radar, demonstrates the feasibility of new radar concepts and systems, performs related systems analysis and evaluation of radar, and provides special consultative services. The emphasis is on new and advanced concepts and technology in radar and related sensors which are applicable to enhancing the Navy's ability to fulfill its mission.

Key Personnel

Name	Title
Dr. M.I. Skolnik	Superintendent
Mr. I.D. Olin	Associate Superintendent
Ms. Denise Mignogno	Administrative Officer
Dr. L.B. Wetzel	Senior Scientist and Head, Propagation Staff
Mr. H. Bress	Consultant and NRL STILO
Mr. J.E. Jedrey	Head, Systems Research Staff
Dr. G.V. Trunk	Head, Radar Analysis Branch
Mr. J.M. Headrick	Head, Radar Techniques Branch
Dr. C.L. Temes	Head, Search Radar Branch
Mr. S.K. Meads	Head, Target Characteristics Branch
Mr. C.M. Veronda	Head, Identification Systems Branch
Mr. T.L. apRhys	Head, Airborne Radar Branch
Mr. T.C. Cheston	Head, Electromagnetics Branch
Dr. A.F. Petty	Head, Systems Control & Research Branch

Personnel

Full-time civilian: 153
Point of contact: Mr. I.D. Olin, Code 5301, 767-2089

Tactical Electronic Warfare Division

Staff Activities

Long-Range EW Strategic Planning

Long-range Navy EW research and development planning
R&D resource requirements

Lead Laboratory Coordinating

EW Program Liaison
Program reference center
Navy Electronic Warfare Advisory Group (NEWAG)
Navy 5-yr EW Plan

Central Target Simulator Program

Develop and operate CTS Facilities
Hardware-in-the-loop modeling

Effectiveness of Naval EW Systems (ENEWS)

EW effectiveness
Simulation analysis and measurement
Research and development support

Special Project Group

Vulnerability analyses
Special countermeasures
Threat signal analysis

Counter C³ I

Battle Group C-C³ systems concepts
C-C³ exploratory R&D requirements

Special Facilities Development Group

Long-range facility planning
Facility update and modernization
Interactive facility integration

Research Activity Areas

Ships Electronic Warfare Systems

Ships systems development
Jamming technology
Deception techniques
EW antennas
Threat simulators

Off-Board Countermeasures

Expendable technology
Expendable devices
Off-board systems
Decoys

Electronic Warfare Support Measures

Intercept systems and direction finders
RF signal simulators
Systems integration
Command and control interfaces
Signal processing

Airborne Electronic Warfare Systems

Air systems development
Penetration aids
Power source development
Jamming and Deception

Advanced Techniques

Analysis and modeling simulation
New EW techniques
Experimental systems
EW concepts

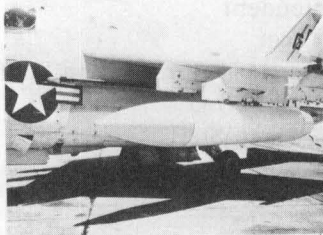

TEW-Designed Missile Simulator
Mounted on A-7 Aircraft

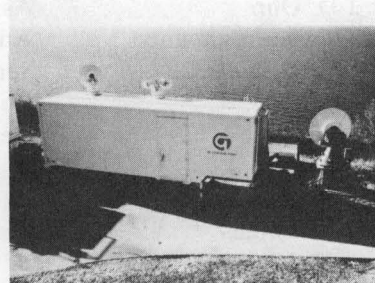

NRL Step Frequency RCS Facility

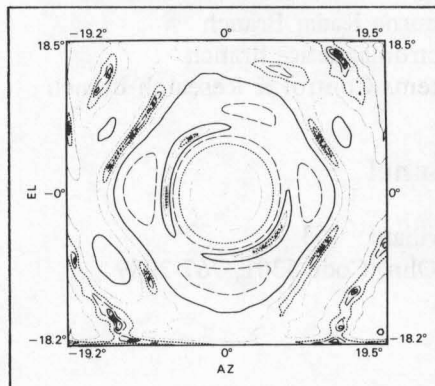

Antenna Polarization Characterization

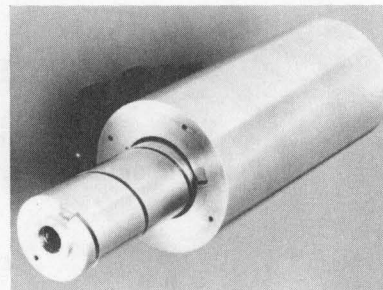

Millimeter Wave Power Source Research

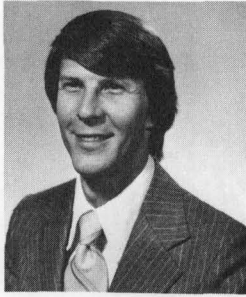

Dr. J.A. Montgomery

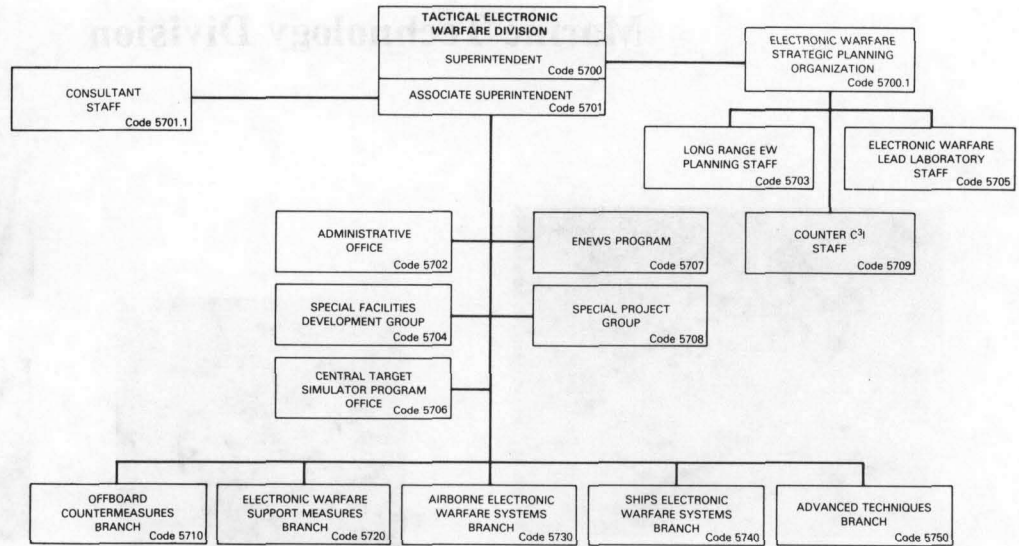

Basic Responsibilities

The Tactical Electronic Warfare Division is responsible for research and development in support of the Navy's tactical electronic warfare requirements and missions. These include electronic warfare support measures, electronic countermeasures, and supporting counter-countermeasures, as well as studies, analyses, and simulations for the determination and improvements of the effectiveness of these systems.

Key Personnel

Name	Title
Dr. J.A. Montgomery	Superintendent
Dr. G.P. Ohman	Associate Superintendent
Dr. C.H. Heider	Head, EW Strategic Planning Organization
Mrs. C. Rulapaugh	Administrative Officer
Mr. G. Meades	Division DILO
Dr. C.H. Heider*	Head, Long-Range EW Planning Staff
Mr. H.M. Suski	Head, Special Facilities Development Group
Mr. R.L. Aberg	Head, Electronic Warfare Lead Laboratory Staff
Mr. A.A. Di Mattesa	Manager, Central Target Simulator Program
Mr. D.F. Grady	Manager, ENEWS Program
Mr. D.S. Leroy	Manager, Special Project Group
Mr. L.O. Sweet	Head, Counter-C ³ I Staff
Dr. F.J. Klemm	Head, Offboard Countermeasures Branch
Mr. H.W. Zwack	Head, Electronic Warfare Support Measures Branch
Mr. E.E. Koos	Head, Airborne Electronic Warfare Systems Branch
Mr. H.E. Crecraft	Head, Ships Electronic Warfare Systems Branch
Dr. G.E. Friedman	Head, Advanced Techniques Branch

Personnel

Full-time civilian: 193

Point of contact: Dr. G.P. Ohman, Code 5701, 767-3622

*Acting

Marine Technology Division

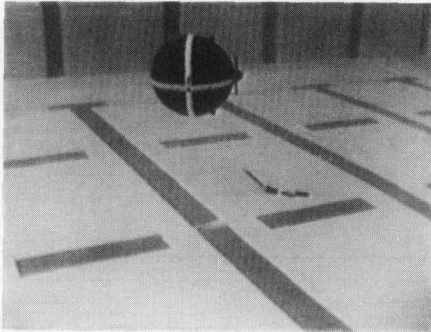

Undersea Observation Vehicle (UOV) Prototype Model for Controllability Tests

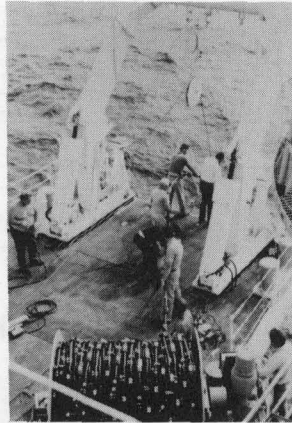

Ocean Fine-Scale Variability Experiments

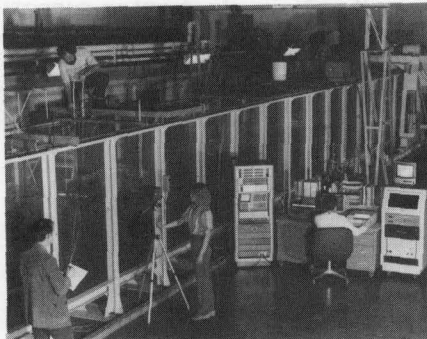

Wind-Wave Tank

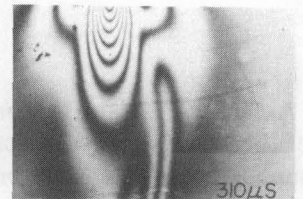
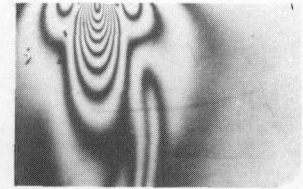
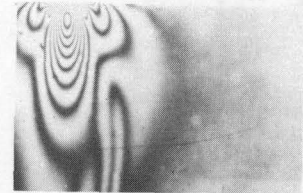

Optical Visualization of Impact-Generated Rayleigh Wave

Staff Activities

Shock and Vibration Information Center

Research Activity Areas

Fluid Dynamics

- Fluid-structure interactions
- Flow-generated noise studies
- Boundary layer hydrodynamics
- Wake hydrodynamics

Structural Integrity

- Failure mechanisms in advanced structural materials
- Reliability analysis and failure modes of components and systems
- Advanced techniques for nondestructive evaluation
- Ship and submarine shock protection
- Component response to shock and vibration

Marine Systems

- Autonomous vehicle development
- Vehicle stability, control, and navigation
- Sensor research and development
- Adaptive sensor and control systems

Ocean Dynamics

- Mesoscale, fine-structure, micro-structure variability
- Mixed layer and thermocline applications
- Ocean towed instrumentation techniques



Dr. R.T. Swim

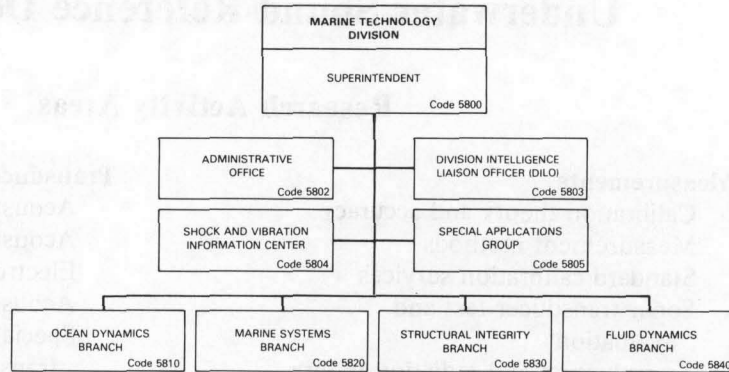

Basic Responsibilities

The Marine Technology Division conducts research and development programs to provide the technology base for marine engineering. The goal is to establish principles and systematic procedures for the design of marine systems and structures and for the performance of marine operations. In the Staff Activities, the Shock and Vibration Information Center provides services for engineers nationwide.

Key Personnel

Name	Title
Dr. R.T. Swim	Superintendent
Mrs. E.M. Coates	Administrative Officer
Dr. J.G. Showalter*	Head, Shock and Vibration Information Center
Mr. E.E. Rudd	Head, Ocean Dynamics Branch
Mr. H.A. Johnson	Head, Marine Systems Branch
Dr. C.I. Chang	Head, Structural Integrity Branch
Dr. O.M. Griffin*	Head, Fluid Dynamics Branch

Personnel

Full-time civilian: 93

Military: 49

Point of contact: Dr. R.J. Swim, Code 5800, 767-3314

*Acting

Underwater Sound Reference Detachment

Research Activity Areas

Measurements

- Calibration theory and accuracy
- Measurement methods
- Standard calibration services
- Sonar transducer test and evaluation
- Transduction and radiation theory
- Wave-number calibration
- Shock testing

Acoustical Systems

- Computation services
- Digital systems
- Analog systems
- Signal analysis
- Low noise preamplifiers
- Measurement systems

Transducer

- Acoustic materials
- Acoustic material measurements
- Electroacoustic standards
- Acoustic sources
- Specialized electroacoustic transducers
- Standard loan services
- Transduction
- Transducer reliability
- Sonar transducers
- Accelerated life testing

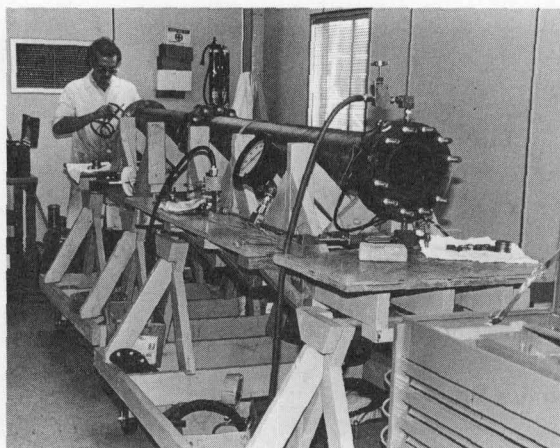

Prototype of Explosive-Shock Tube

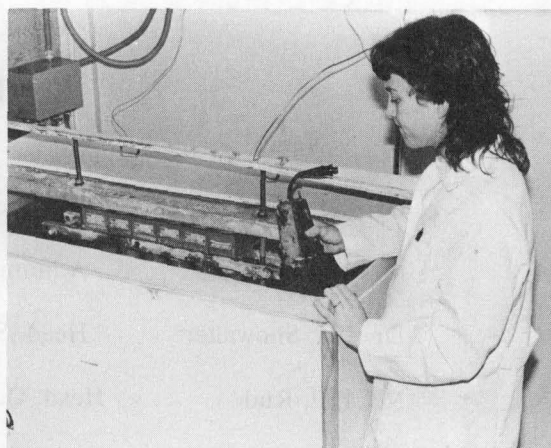

Portion of Accelerated-Life Testing Laboratory

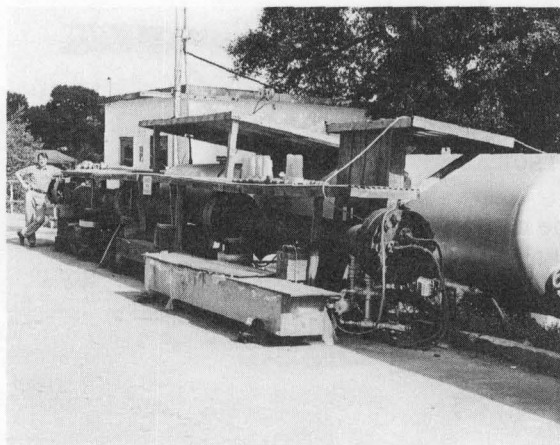

Long-Line Hydrophone Calibrator

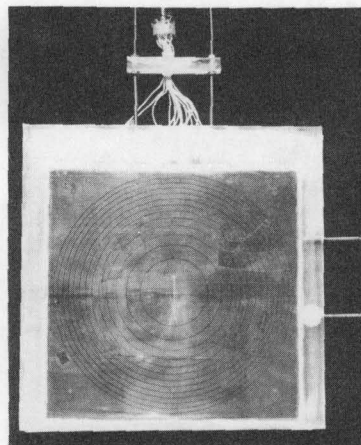

Piezoelectric Polymer Nearfield Calibration Array

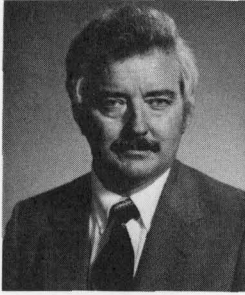

Dr. J.E. Blue

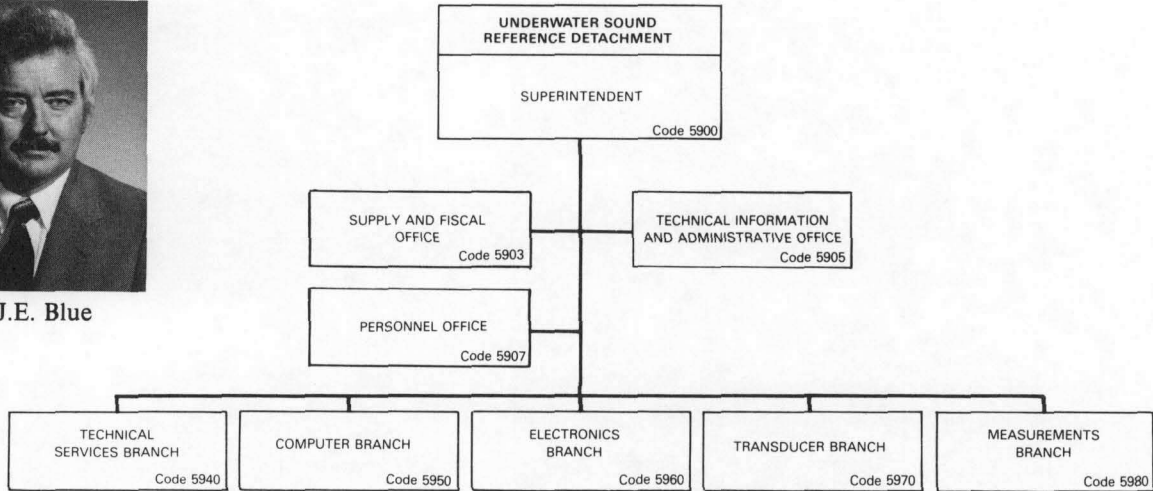

Basic Responsibilities

The Underwater Sound Reference Detachment is the focal point in the Navy for standardization in the science and technology of underwater sound measurements. Its research and development program is aimed at expanding the state of the art and providing Navy in-house expertise. Reference calibration measurements in a large complex of specialized facilities and calibrated standard transducers are available to all naval activities and contractors in support of undersea warfare programs. The Detachment also provides expertise in nonlinear acoustics, nearfield arrays and measurements, radiation theory, and underwater electroacoustic sensors.

Key Personnel

Name	Title
Dr. J.E. Blue	Superintendent
Mr. H.F. Bowman	Head, Supply and Fiscal Office
Ms. D.A. Pieper	Head, Technical Information Office
Ms. M.S. Lutman	Head, Personnel Office
Mr. G. Woods	Head, Technical Services Branch
Mr. R.E. Scott*	Head, Acoustical Systems Branch
Mr. C.K. Brown	Head, Electronics Branch
Dr. R.W. Timme	Head, Transducer Branch
Dr. A.L. Van Buren	Head, Measurements Branch

Personnel

Full-time civilian: 99

Point of contact: Mrs. L.R. Jevnager, Code 5905.1, (305) 857-5237

*Acting

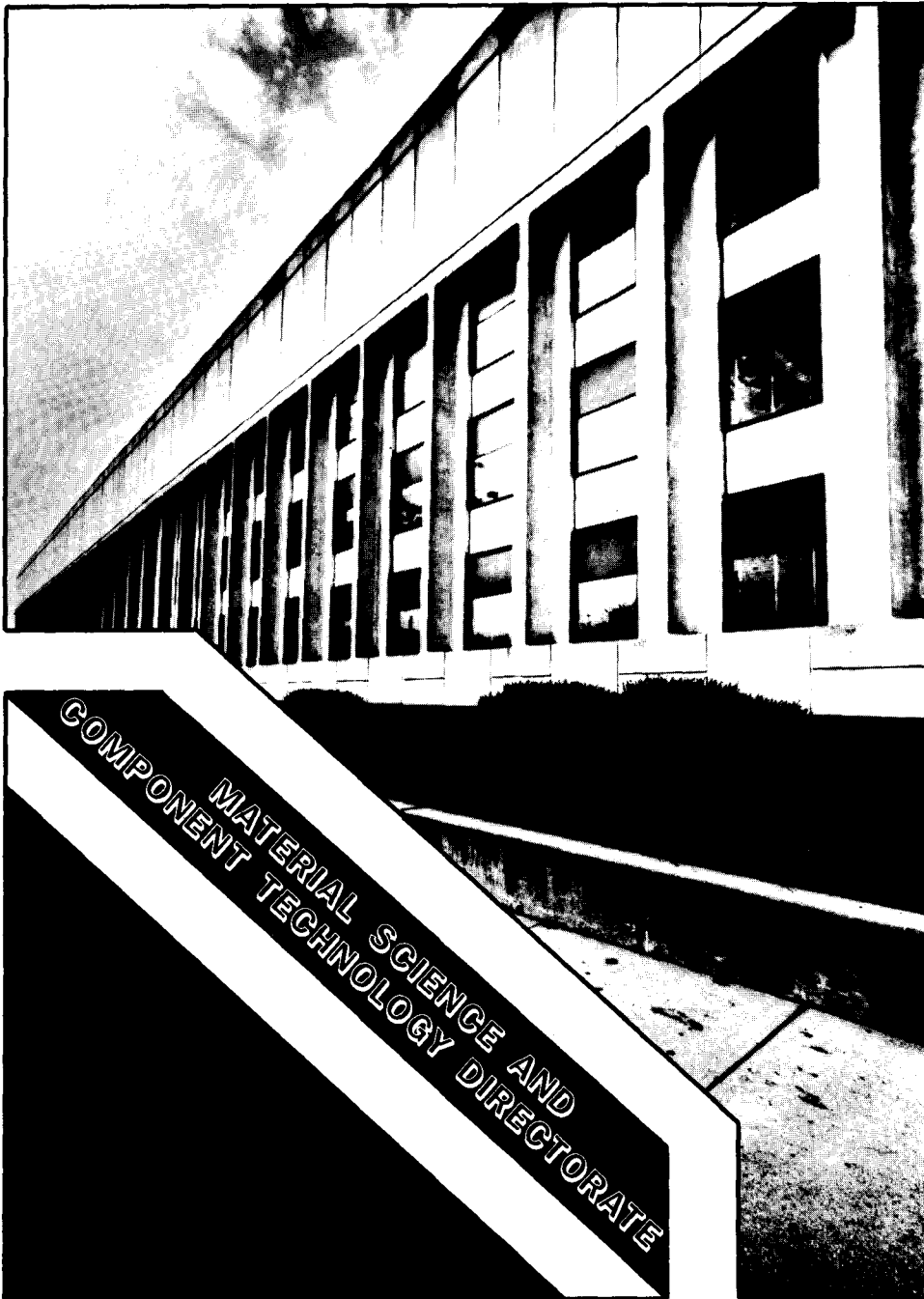

**MATERIAL SCIENCE AND
TECHNOLOGY DIRECTORATE
COMPONENT**

Material Science and Component Technology Directorate

The Material Science and Component Technology Directorate carries out a multidisciplinary research program whose objectives are the discovery and exploitation of new improved materials, the generation of new concepts associated with materials behavior, and the development of advanced components based on these new and improved materials and concepts. Theoretical and experimental research is carried out to determine the scientific origins of materials behavior and to develop procedures for modifying these materials to meet important Navy needs such as fire suppression. The program includes investigations of a broad spectrum of materials including insulators, semiconductors, metals and alloys, optical materials, polymers, plastics, and composites which are used in important naval devices, components, and systems. New techniques are developed for producing, processing, and fabricating these materials for crucial naval applications.

The limits of performance of these materials, natural or nuclear radiation environments, components under deleterious conditions such as those associated with the marine environment, neutron or directed energy beam irradiation, or extreme temperatures and pressures, are established.

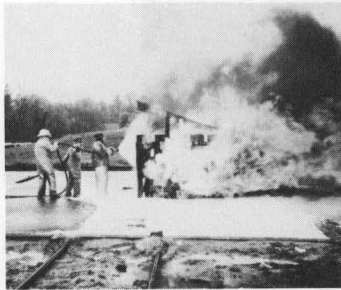

Chemistry for Fire Suppression

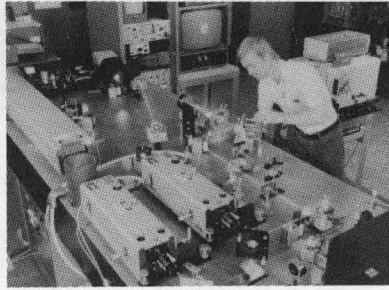

Optical Physics— Scanning Laser Microscope

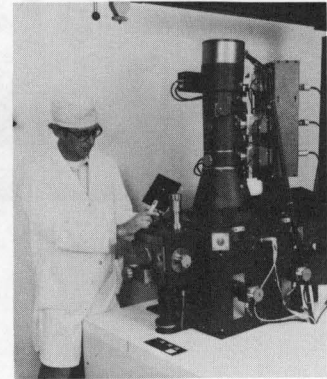

*Microelectronics Processing—
Electron Beam Lithography*

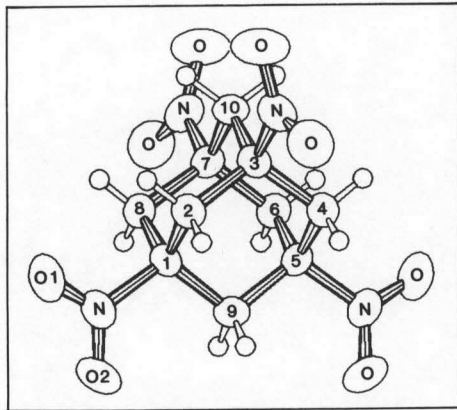

Structure of Matter—Propellants Research

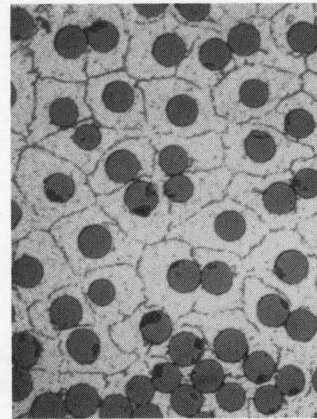

*Material Science—
Graphite Fibers in Aluminum*

Associate Director of Research for Material Science and Component Technology



Dr. W. Tolles, Dr. D. Nagel, Dr. T. Giallorenzi, Dr. G. Borsuk, Dr. B. Rath

Information in the 1986 Fact Book is current as of 1 October 1985. At that time, the position of Associate Director of Research for Material Science and Component Technology was vacant. Until a new Associate Director is selected, responsibility as Acting Director is rotated on a bimonthly basis among the superintendents within the Directorate.

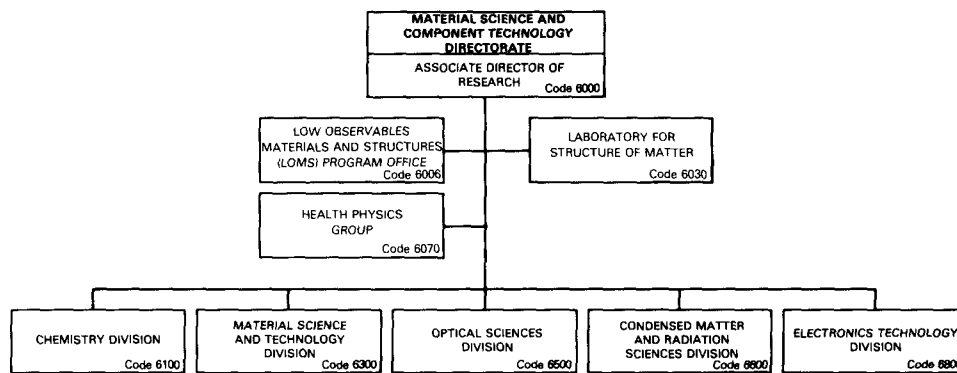

*

Key Personnel

Name	Title	Code
Vacant	Associate Director of Research for Material Science and Component Technology	6000
Dr. D. Forester	Program Manager, Project LOMS	6006
Dr. J. Karle	Chief Scientist, Laboratory for Structure of Matter	6030
Mr. J.N. Stone	Head, Health Physics Staff	6070
Dr. W.M. Tolles	Superintendent, Chemistry Division	6100
Dr. B.B. Rath	Superintendent, Material Science and Technology Division	6300
Dr. T.G. Giallorenzi	Superintendent, Optical Sciences Division	6500
Dr. D.J. Nagel	Superintendent, Condensed Matter and Radiation Sciences Division	6600
Dr. G.M. Borsuk	Superintendent, Electronics Technology Division	6800

Point of contact: Virginia Bradley, Code 6000A, 767-3566

*Effective 1 January 1986, the Condensed Matter and Radiation Sciences Division (Code 6600) and the Health Physics Group (Code 6070) became part of the General Science and Technology Directorate. Their new codes are Code 4600 and Code 4070, respectively.

Laboratory for Structure of Matter (Code 6030)

Basic Responsibilities

The Laboratory for Structure of Matter carries out experimental and theoretical investigations of the atomic, molecular, glassy, and crystalline structures of materials. The methods of x-ray, electron, and neutron diffraction are used in a broad program of structural studies which can form the basis for understanding and interpreting the results of research investigations in a wide variety of scientific disciplines. Structural investigations relate structure to function, facilitate industrial syntheses and the creation of new materials with improved properties, and provide foundation information for numerous associated disciplines and studies. Applications are made, for example, to propellants, explosives, dense energetic materials, absorptive carbons, metallic glasses, device materials, ion carriers, antibiotics, analgesics, reversible oxygen carriers, and synthetic reaction intermediates and final products.

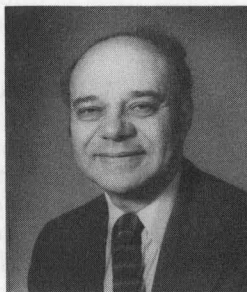

Dr. J. Karle

Key Personnel

Name	Title
Dr. J. Karle	Chief Scientist, Laboratory for Structure of Matter

Personnel

Full-time civilian: 12

Point of contact: Dr. Clifford George, Code 6030, 767-3463

Chemistry Division

Staff Activity

Fire Protection and Damage Control
Program Office

Research Activity Areas

Chemical Diagnostics

Optical diagnostics of chemical reactions
Kinetics of gas phase reactions
Chemical lasers and energy transfer
Trace analysis
Atmosphere analysis and control

Polymeric Materials

Synthesis and evaluation of innovative polymers
Functional organic coatings
Polymer characterization
Nondestructive evaluation
Quality control methodology
Degradation and stabilization mechanisms
Electroactive polymers
Synthesis and characterization of novel inorganic compounds
High temperature chemistry
Theoretical chemistry

Surface/Interface Chemistry

Tribology
Surface properties of materials
Surface/interface analysis
Graphite and carbon materials
Chemical microdetectors
IR/RF decoy materials
Surface modification

Inorganic & Electrochemistry

Beam enhanced chemistry
Fundamental electrode reactions
Corrosion prevention
High temperature chemistry
Hetero- and homogeneous catalysis

Combustion & Fuels

Distillate fuels research
Combustion dynamics
Fire protection and suppression
Personnel protection
Modeling and scaling of combustion systems
Chemical and biological defense
Synthetic fuels

Bio/Molecular Engineering

Biophysical chemistry
Immunochemistry
Biomembranes
Lipid and protein structure
Molecular graphics
Biosensors
Polymerizable lipids
Langmuir-Blodgett films
Red blood cell surrogate
Bio-derived microstructures



*Impact of Fires in Enclosed Spaces—
NRL's 324-m³ Facility*



*Studying Red Blood Cell Surrogate
in the Cold Room*

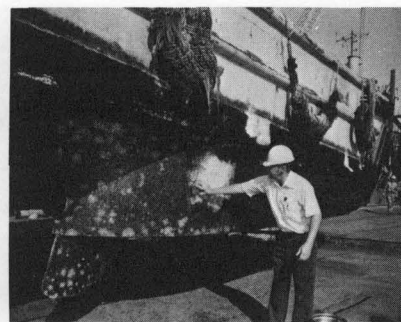

Fouling Release Coatings



Laser Diagnostics

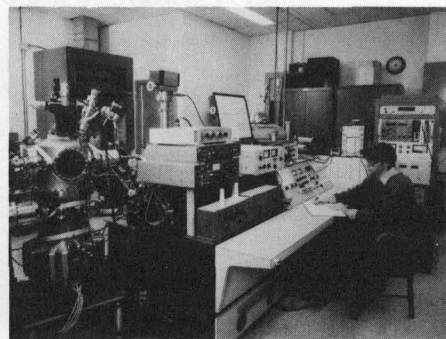

*Secondary Ion Mass Spectrometer Designed to
Desorb Intact Molecular and Polyatomic Ions
from Surfaces*



Dr. W. M. Tolles

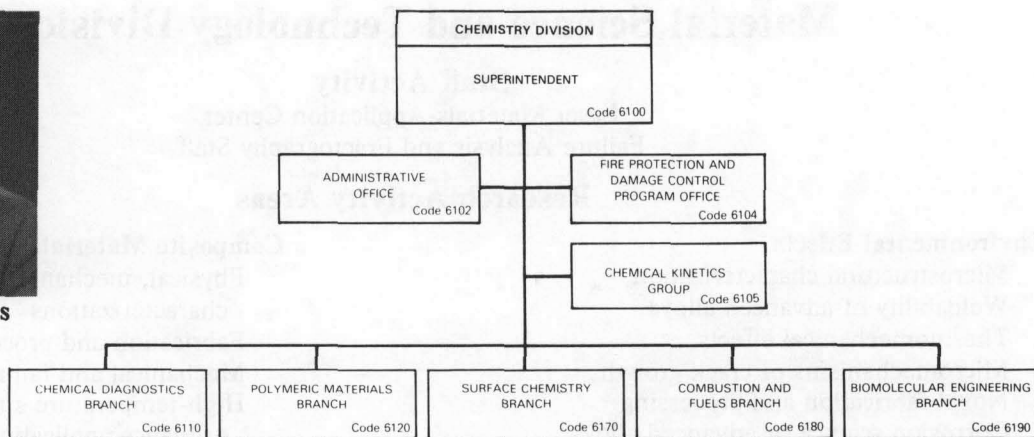

Basic Responsibilities

The Chemistry Division conducts basic and applied research and development studies in the broad fields of chemical diagnostics, polymeric materials, surface and electrochemistry, bio/molecular engineering, combustion, and fuels chemistry. Specialized programs within these fields include organic polymeric materials, coatings, dynamics, laser chemistry, electroactive polymers, tribology, physical and chemical characterization of surfaces and theory of surfaces, chemistry of electronic materials, submarine atmosphere analysis and control, lipid chemistry, membranes and novel structures, sensors, solution chemistry, personnel protection (including chemical and biological defenses), fire suppression, and the chemistry and physics of synfuels.

Key Personnel

Name	Title
Dr. W.M. Tolles	Superintendent
Dr. W.B. Fox	Associate Superintendent
Ms. B.L. Russell	Administrative Officer
Dr. H.W. Carhart	Head, Fire Protection and Damage Control Program Office
Dr. M.C. Lin	Head, Chemical Kinetics Group
Dr. A.B. Harvey	Head, Chemical Diagnostics Branch
Dr. W.B. Moniz	Head, Polymeric Materials Branch
Dr. J.S. Murday	Head, Surface Chemistry Branch
Dr. H.W. Carhart	Head, Combustion and Fuels Branch
Dr. J. Schnur	Head, Bio/Molecular Engineering Branch

Personnel

Full-time civilian: 117
 Point of contact: Ms. Brenda Russell, Code 6102, 767-2460

Material Science and Technology Division

Staff Activity

Laser Materials-Application Center
Failure Analysis and Fractography Staff

Research Activity Areas

Environmental Effects

- Microstructural characterization
- Weldability of advanced alloys
- Thermomechanical effects
- Micromechanisms of crack growth
- Novel fabrication and processing
- Corrosion science of advanced alloys
- Stress corrosion cracking
- Surface protection and inhibitors
- Corrosion mechanisms
- Marine corrosion and cathodic protection

Physical Metallurgy

- Phase transformations
- Crystalline defect states
- Microstructural effects on properties
- Elasticity, plasticity, mechanical phenomena
- Laser welding
- Alloy development
- Laser surface processing
- Ion implantation
- Small angle neutron scattering
- Rapid solidification processing of materials

Mechanics of Materials

- Subcritical crack growth and fracture
- Environmental effects
- Failure-safe design parameters
- Metallurgical optimization for high-strength metals
- Failure criteria
- Computational mechanics
- Fracture mechanics
- Structural mechanics
- Constitutive theories

Composite Materials

- Physical, mechanical, and failure characterizations
- Fabrication and processing techniques
- Mechanical and failure analyses
- High-temperature structural and ordnance applications

Ceramics

- Processing and fabrication
- Microstructural characterization
- Strength and fracture behavior
- Thermostructural applications
- Ceramics for electronic, piezo-electric, optical, and other nonmechanical applications

Thermostructural Materials

- Elevated temperature behavior of materials
- Influence of environment on high-temperature materials
- Basic mechanisms of radiation damage
- Criteria for improved structural design using high-temperature materials

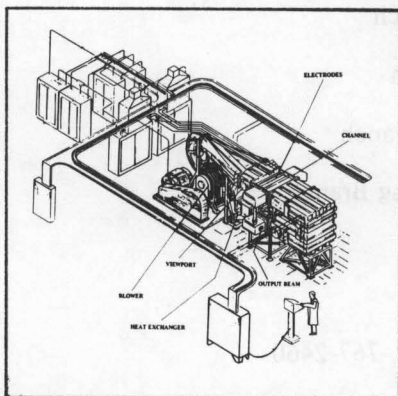

Laser Materials-Application Center

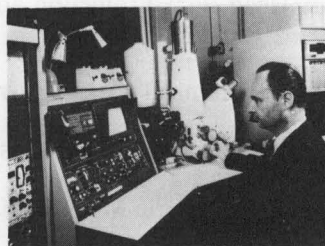

Scanning Electron Microscope and Microprobe Analyzer

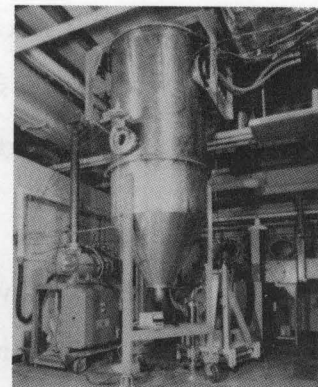

Ultrasonic Gas Atomizer

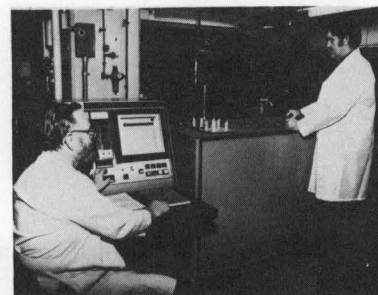

Hot Isostatic Pressing of Materials



Dr. B.B. Rath

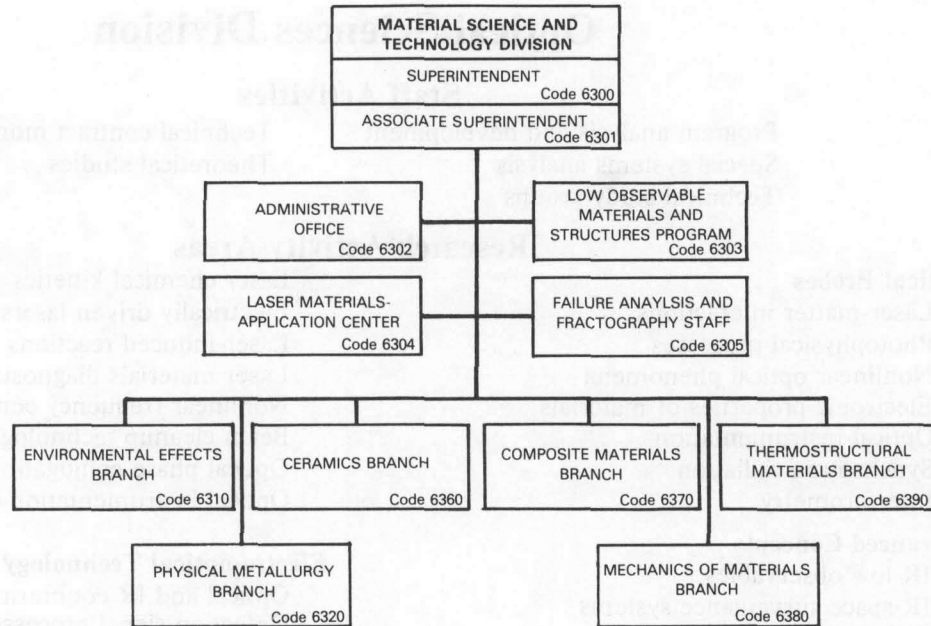

Basic Responsibilities

The Material Science and Technology Division conducts basic and applied research and engages in exploratory and advanced development of materials technology having substantive value to the Navy. R&D programs encompass the intrinsic behavior of metals, alloys, ceramics, glasses, and composites, and their performance and reliability in naval structures and devices. Program objectives include achieving fundamental understanding of the mechanical, physical, and electrochemical properties of materials; identifying composition, processing, and microstructural parameters to produce improved materials; and developing guidelines for the selection, design and certification of materials for life-cycle management of naval structures and systems. This diversity of programs is carried out by interdisciplinary teams of material scientists, metallurgists, ceramists, physicists, chemists, and engineers, using the most advanced testing facilities and diagnostic techniques.

Key Personnel

Name	Title
Dr. B.B. Rath	Superintendent
Mr. R.J. Goode	Associate Superintendent
Mrs. E. Wray	Administrative Officer
Dr. D. Forester	Program Manager, Project LOMS Program Office
Mr. R.L. Stegman	Head, Laser Materials-Application Center
Mr. C.D. Beachem	Head, Failure and Fractography Analysis Staff
Mr. T.W. Crooker	Head, Environmental Effects Branch
Dr. R.A. Vandermeer	Head, Physical Metallurgy Branch
Dr. D. Lewis III*	Head, Ceramics Branch
Dr. S.C. Sanday	Head, Composite Materials Branch
Mr. Dr. R. Badaliance	Head, Mechanics of Materials Branch
Mr. L.E. Steele	Head, Thermostructural Materials Branch

Personnel

Full-time civilian: 87

Point of contact: Dr. B.B. Rath, Code 6300, 767-2926

* Acting

Optical Sciences Division

Staff Activities

Program analysis and development Technical contract monitoring
Special systems analysis Theoretical studies
Technical study groups

Research Activity Areas

Optical Probes

Laser-matter interactions
Photophysical processes
Nonlinear optical phenomena
Electronic properties of materials
Optical instrumentation
Synchrotron radiation
Interferometry

Advanced Concepts

IR low observables
IR space surveillance systems
EO/IR systems analysis
Airborne IR search and track technology
Atmospheric IR measurements
Ship IR signatures

Applied Optics

Optical image and information processing
Optical technology
Ultraviolet component development and
UV countermeasures
Atmospheric optics
Propagation studies

Laser Physics

Molecular and chemical laser physics
Interferometry

Laser chemical kinetics
Electrically driven lasers
Laser-induced reactions
Laser materials diagnostics
Nonlinear frequency conversion
Beam cleanup technology
Optical phase conjugation
Optical instrumentation and probes

Electro-optical Technology

Optical and IR countermeasures
Detection signal processing studies
Optical seeker studies
Solid state laser development
Optical imager development
Optical interactions in semi-conductor systems

Optical Techniques

Picosecond light pulses
Diode laser applications
Optical waveguides
Radiation-induced defects
Optical control of solid state electronic devices
Fiberoptic sensors
Integrated optics
Fiberoptic materials and fabrication

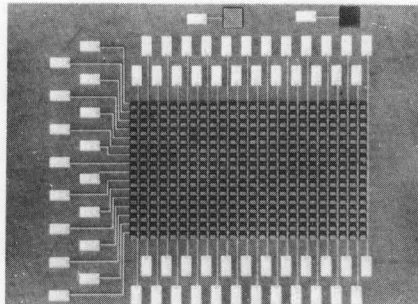

Focal Plane Array

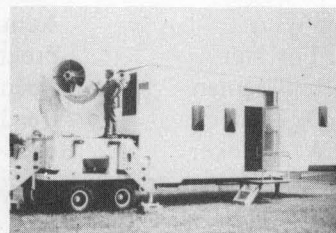

*High Precision Tracker
and Trailer*

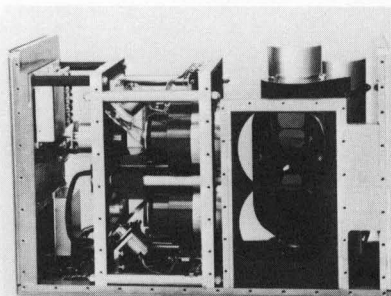

IR Background Measurement Sensor

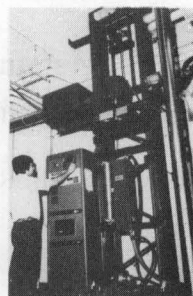

Fiber Draw Facility

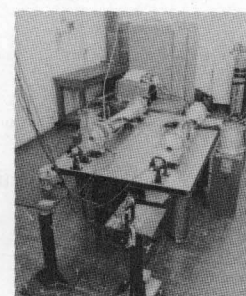

Twin Pulsed Chemical Lasers

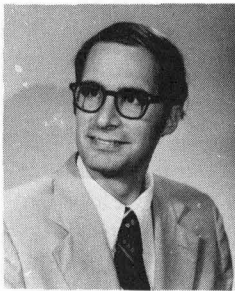

Dr. T.G. Giallorenzi

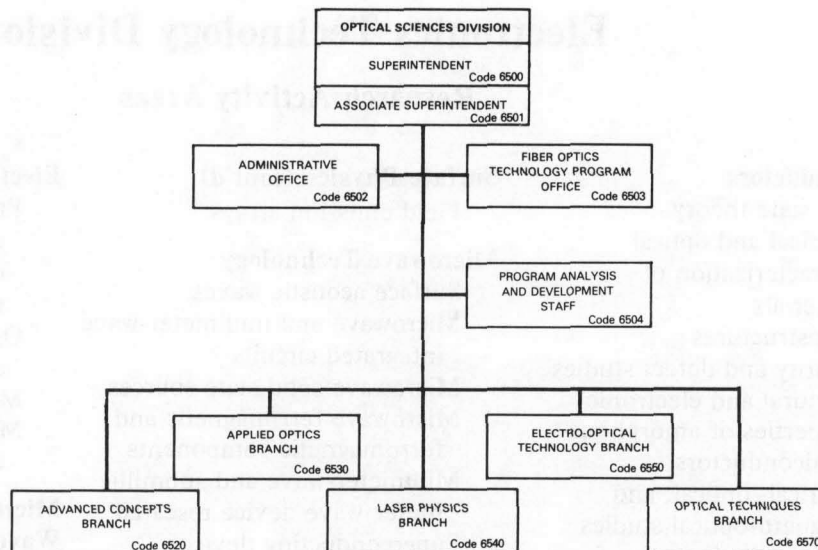

Basic Responsibilities

The Optical Sciences Division carries out a variety of research, development, and application-oriented activities in the generation, propagation, detection, and use of radiation in the wavelength region between near-ultraviolet and far-infrared wavelengths. The research, both theoretical and experimental, is concerned with discovering and understanding the basic physical principles and mechanisms involved in optical devices, materials, and phenomena. The development effort is aimed at extending this understanding in the direction of device engineering and advanced operational techniques. The applications activities include systems analysis, prototype system development, and exploitation of R&D results for the solution of optically related military problems. In addition to its internal program activities, the Division serves the Laboratory specifically and the Navy generally as a consulting body of experts in optical sciences. The work in the Division includes studies in quantum optics, laser physics, optical waveguide technologies, laser-matter interactions, atmospheric propagation, optical technology, holography, optical warfare, optical data processing, optical systems, optical materials, radiation damage studies, IR surveillance and missile seeker technologies, IR signature measurements, optical recording materials, and optical diagnostic techniques. A significant portion of the effort is devoted to developing, analyzing, and using special optical materials. Various field measurement programs on optical problems of specific interest are also conducted.

Key Personnel

Name	Title
Dr. T.G. Giallorenzi	Superintendent
Mr. J.M. McMahon	Associate Superintendent
Mrs. D.D. Nolan	Administrative Officer
Dr. J.C. Kershenstein	Program Analysis & Development Staff
Mr. J.M. McMahon	Program Analysis & Development Staff
Dr. R.A. Patten	Program Analysis & Development Staff
Dr. D.L. Esterowitz	Program Analysis & Development Staff
Mr. J.E. Donovan	Head, Fiber Optics Technology Program Office
Dr. J.C. Kershenstein	Head, Advanced Concepts Branch
Dr. R.A. Patten	Head, Applied Optics Branch
Dr. B. Feldman	Head, Laser Physics Branch
Dr. L. Esterowitz	Head, Electrooptical Technology Branch
Dr. H. Taylor	Head, Optical Techniques Branch

Personnel

Full-time civilian: 128

Point of contact: Mrs. D. Nolan, Code 6502, 767-2855

*Acting

Electronics Technology Division

Research Activity Areas

Semiconductors

Solid state theory
Electrical and optical characterization of materials
Microstructures
Impurity and defect studies
Structural and electronic properties of amorphous semiconductors
Electrical, optical, and magneto-optical studies of semiconductor surfaces and interfaces

Surface Physics

Surface and interface physics
Cathode research and development
Processing research for submicron electronics
Characterization and growth of semiconductor, metal, and insulator films and surfaces
Thermionic energy conversion

Surface Physics (cont'd)

Field emission arrays

Microwave Technology

Surface acoustic waves
Microwave and millimeter-wave integrated circuits
Microwave solid state sources
Microwave ferrimagnetic and ferromagnetic components
Millimeter-wave and submillimeter-wave device research
Superconducting devices and circuits

Solid State Devices

Ion implantation technology
High- and low-power devices for energy conversion
Field effect transistor reliability and failure analysis
MIS failure physics, radiation vulnerability and hardening
High-frequency microwave devices
IC device technology
Solid state optical sensors

Electronic Material Technology

Preparation and development of magnetic, dielectric, optic, and semiconductor materials
Optical components and coatings
Molecular beam epitaxy
Metal organic chemical vapor deposition

Microwave and Millimeter Wave Tube Technology

Microwave and millimeter power amplifier research and development
Amplifier theory and analysis
Supportive technology development
Tube fabrication and support technology
Manufacturing technology

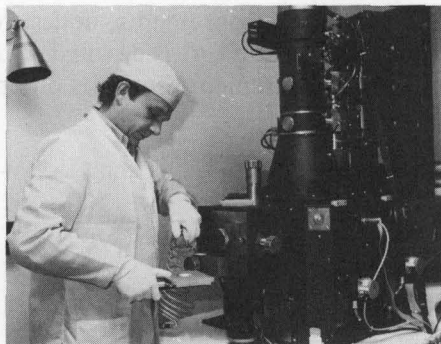

High Resolution Electron Beam Lithography System

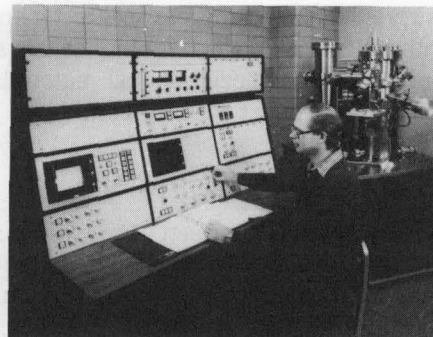

Ultrahigh Vacuum Scanning Electronic Microscope

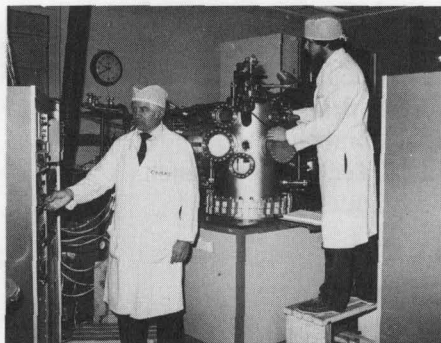

Molecular Beam III-V Compound Epitaxy System

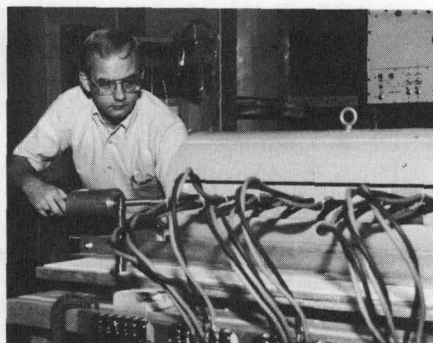

High Power J-Band Ubitron Experiment



Dr. G. M. Borsuk

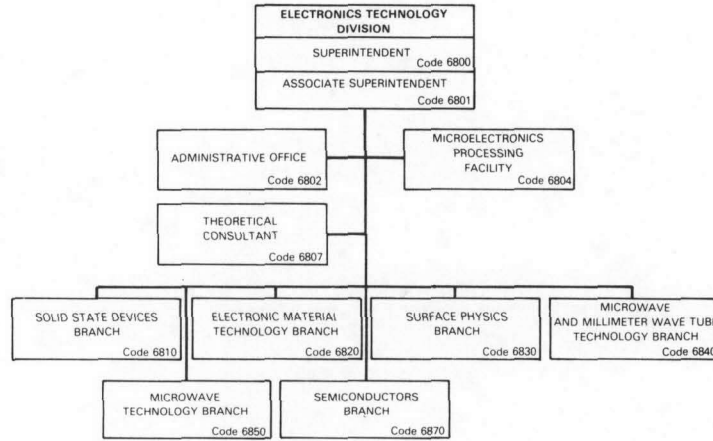

Basic Responsibilities

The Electronics Technology Division conducts programs of basic and applied research and development in the fields of electronic properties of solid materials (especially semiconductors), materials, surface physics, microwave techniques, microelectronic devices research and fabrication, highpower microwave generation, and cryoelectronics. These programs represent major activity in microstructure electronics, microelectronics, materials growth, vacuum electronics, and components and circuits. The activities of the Division couple device research both to basic materials investigations and to systems research and development needs.

Key Personnel

Name	Title
Dr. G.M. Borsuk	Superintendent
Dr. S. Teitler	Associate Superintendent
Mrs. A. McDaniel	Administrative Office
Dr. K.L. Ngai	Theory Consultant
Dr. M.C. Peckerar	Head, Microelectronics Processing Facility
Dr. J.M. Killiany	Head, Solid State Devices Branch
Mr. H. Lessoff	Head, Electronic Material Technology Branch
Dr. R.F. Greene	Head, Surface Physics Branch
Dr. R.K. Parker	Head, Microwave and Millimeter Wave Tube Technology Branch
Dr. B.E. Spielman	Head, Microwave Technology Branch
Dr. S.G. Bishop	Head, Semiconductors Branch

Personnel

Full-time civilian: 127

Point of contact: Dr. Sidney Teitler, Code 6801, 767-2807

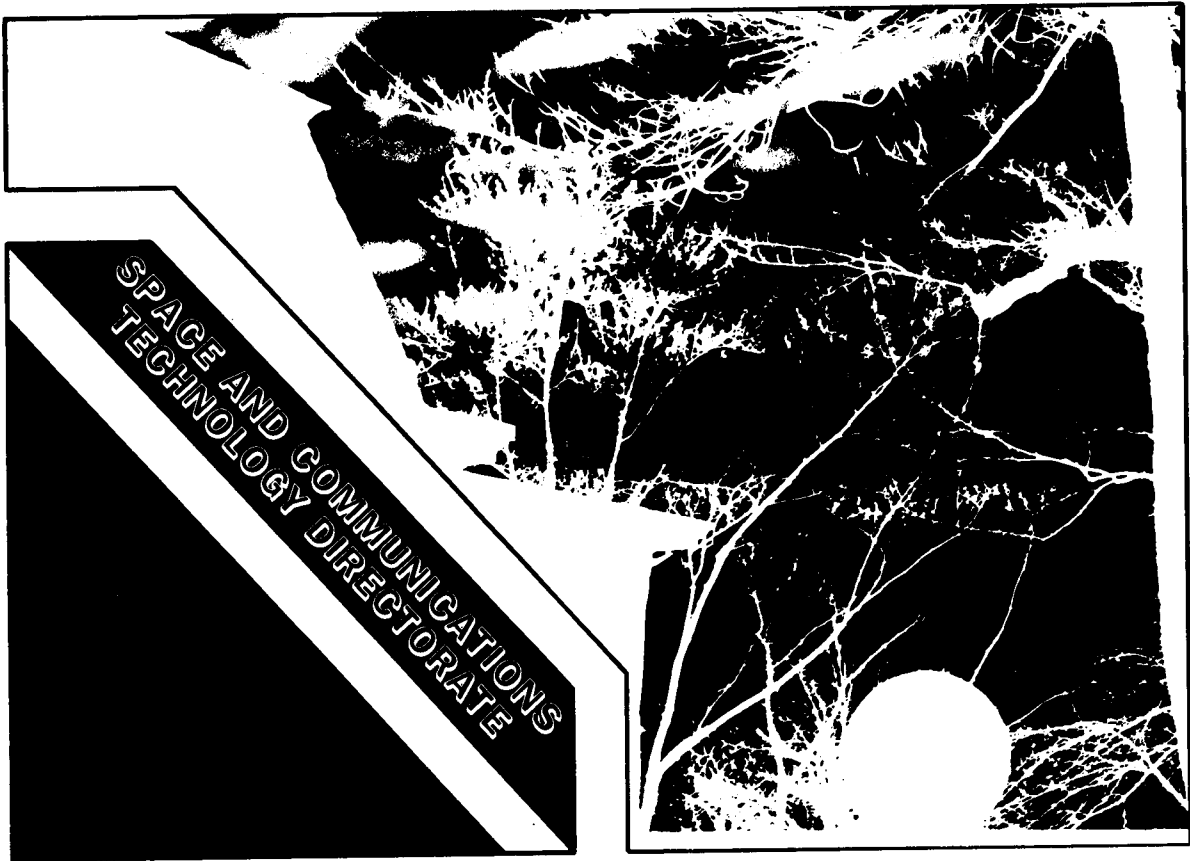

Space and Communications Technology Directorate

This directorate conducts basic and applied research to improve naval capabilities in communications, navigation, detection, surveillance, environmental sensing, and combat management. It also is responsible for research and development in the systems, sensors, techniques, instrumentation, and phenomenology of communications, command and control, signal exploitation, and information processing. Work in these fields is supported by theoretical studies and analyses, as well as by experimental development and flight of payloads. Special facilities for building and testing complete spacecraft are available for on-orbit evaluation of space concepts and techniques.

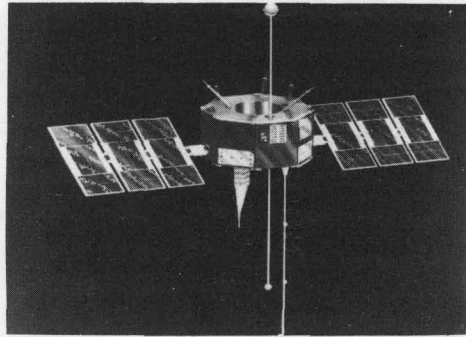

NTS-2



Waldorf Antenna Site

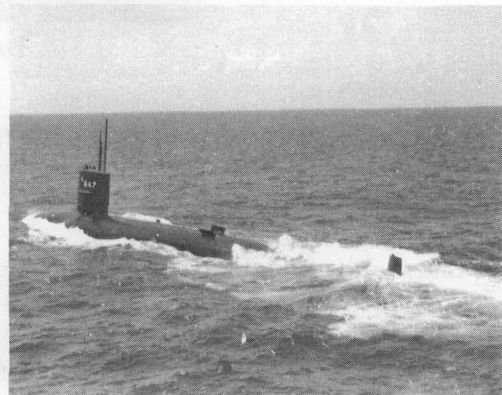

Communication Buoy Test



Space Surveillance System

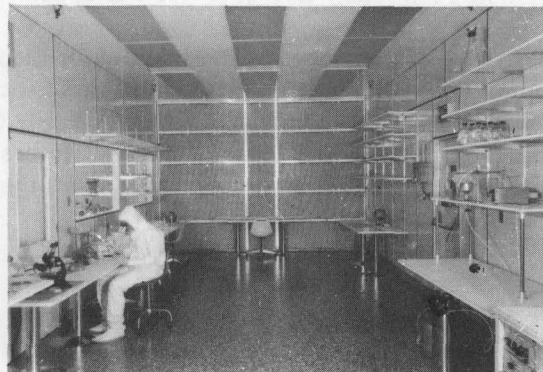

*Satellite Component Assembly
Clean Room*

Associate Director of Research for Space and Communications Technology



Dr. B. Wald

Dr. Wald [REDACTED] He received the degree of A.B. in physics from Bowdoin College in 1953, and of Ph.D. in electrical engineering from the University of Maryland in 1967.

He came to the Countermeasures Branch of the Radio Division of the Naval Research Laboratory in 1953, where he developed intercept receivers and computers for simulating their performance. From 1957 to 1962, he led a group exploring the application of digital technology to direction finding and signal intercept. From 1962 to 1967, he was in charge of the development of the automation of the Bulls Eye target location system.

In 1967, he founded the Information Systems Branch, NRL's first computer science activity. In 1972, he became Superintendent of the Communications Sciences Division, the predecessor of the Information Technology Division. He was appointed to his present position on January 1, 1980.

Dr. Wald is a member of the Institute of Electrical and Electronic Engineers and the Association for Computing Machinery and has served these societies in editorial, conference organization, and refereeing roles. He has taught for the University of Maryland and the George Washington University and has lectured at the Naval War College. He has served as an associate member of the Defense Science Board and has received the Navy's Superior and Meritorious Civilian Service Awards.

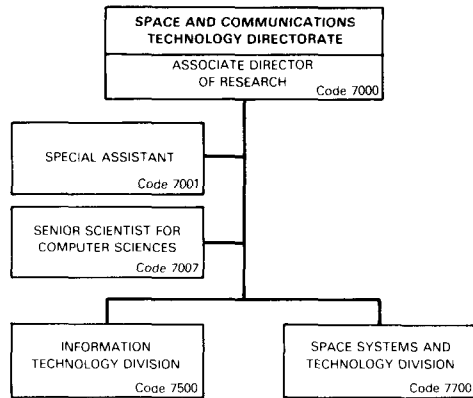

Key Personnel

Name	Title	Code
Dr. B. Wald	Associate Director of Research for Space and Communications Technology	7000
Vacant	Special Assistant	7001
Mr. Y. S. Wu	Senior Scientist	7007
Dr. J.R. Davis	Superintendent, Information Technology Division	7500
Mr. P.G. Wilhelm	Superintendent, Space Systems and Technology Division	7700

Information Technology Division

Research Activity Areas

Navy Center for Applied Research in Artificial Intelligence

- Natural Language for Automated Message Processing
- Multisensor Information Integration
- Expert Systems for Decision Aids and Consultation

Communication System Engineering

- Network design
- Secure communication systems
- Speech processing
- Modulation, coding, and waveform design

Transmission Technology

- Submarine communication technology
- Communication system architecture
- Communication antenna/propagation technology
- Satellite communication system technology

Integrated Warfare Technology

- Combat management information system analyses
- Command information system design
- Communication, command, and control countermeasures
- Signal processing for high-frequency intercept system

Computer Science and Systems

- Software engineering
- Information theory
- Message processing technology

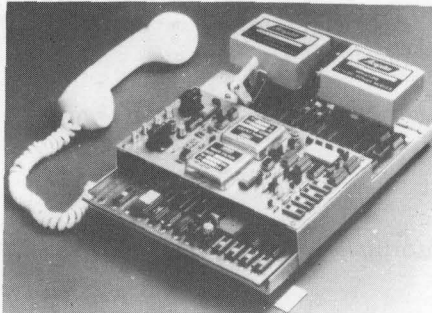

Multirate Processor Digital Voice Terminal

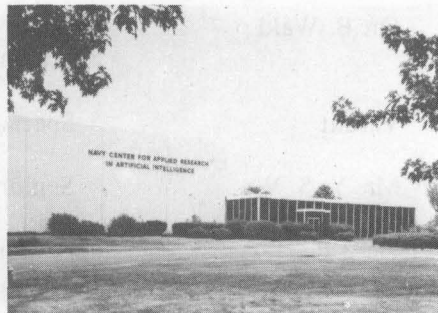

Artificial Intelligence Center

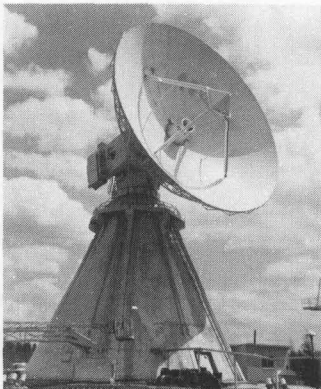

Microwave Space Research Facility

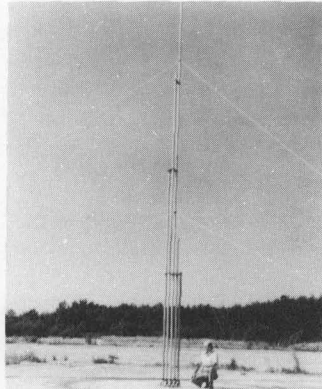

HF Wideband Monopole Transmitting Antenna

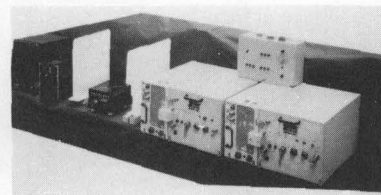

AN/ALQ-149 Communication Jammer

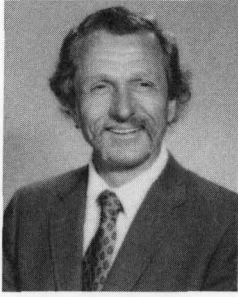

Dr. J.R. Davis

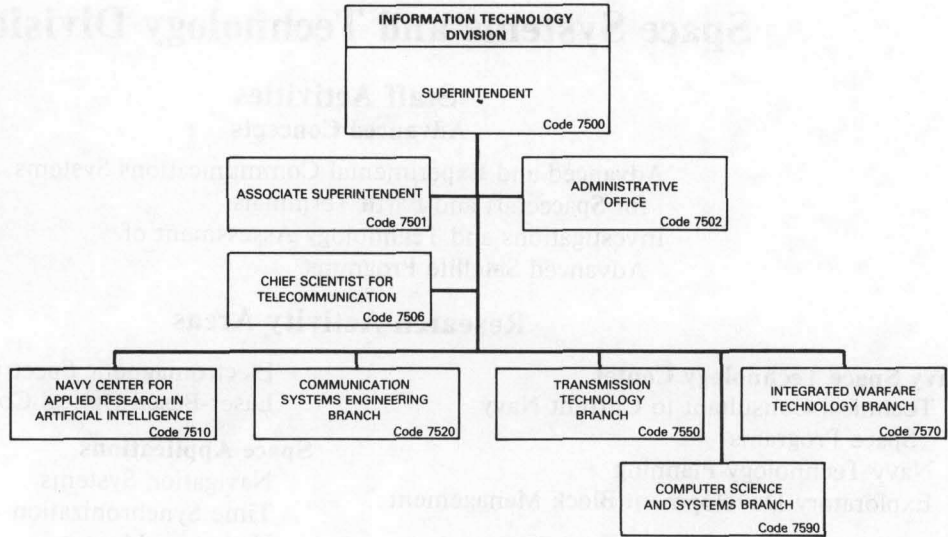

Basic Responsibilities

The Information Technology Division conducts research and development programs in the collection, transmission, and processing of information in order to provide a basis for improvement in the conduct of military operations. The organization of the Division is directed toward addressing the technologies and subsystems necessary to support a combat management information system.

Key Personnel

Name	Title
Dr. J.R. Davis	Superintendent
Mr. W.D. Long	Associate Superintendent
Mrs. C.E. Holt	Administrative Officer
Mr. D.I. Himes	Chief Scientist for Telecommunication
Dr. R.P. Shumaker	Manager, Navy Center for Applied Research in Artificial Intelligence
Mr. E.L. Kline	Head, Communication System Engineering Branch
Mr. D.I. Himes	Head, Transmission Technology Branch
Mr. M.S. McBurnett	Head, Integrated Warfare Technology Branch
Mr. S.H. Wilson	Head, Computer Science and Systems Branch

Personnel

Full-time civilian: 127

Point of contact: W.D. Long, Code 7501, 767-2954

Space Systems and Technology Division

Staff Activities

Advanced Concepts

Advanced and Experimental Communications Systems
for Spacecraft and Earth Terminals
Investigations and Technology Assessment of
Advanced Satellite Programs

Research Activity Areas

Navy Space Technology Center

Technical Consultant to Current Navy
Space Programs
Navy Technology Planning
Exploratory Development Block Management

Electrical Systems and Spacecraft Integration

Spacecraft Power and Ordnance Systems
Aerospace Systems Fabrication
Quality Assurance & Reliability
Survivability Concepts

Terrestrial Systems

Software for Collection Systems Control
Advanced Satellite Ground Station Design
Fleet-Deployed Satellite Systems

Mechanical Systems

Spacecraft Structural Design
Attitude and Thermal Control
Launch Vehicle Integration
Spacecraft Environmental Testing

Radio Frequency & Optical

Advanced Space & Related Ground
Communications Systems
Radio Frequency Active Components & Antennae
Communication Systems Study & Analysis

Electromagnetic Spectrum Utilization

Laser-Based Optical Communication Systems

Space Applications

Navigation Systems
Time Synchronization
Hydrogen Masers
Frequency Standard Development

Space Sensing Applications

Surveillance Sensor & Algorithm Development
Electromagnetic Scatter Research
Surveillance System Performance
Requirements Definition

Systems Engineering & Analysis

Payload Development
Systems Integration & Tests
Space Systems Technical Evaluation

Digital Systems

Spaceborne Signal and
Data Processors Development
Spacecraft Telemetry, Command &
Data Management
Spacecraft Test Systems Design
Astrodynamics Research and Application



Computer-Aided Design Facility

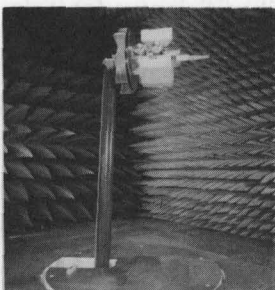

R.F. Anechoic Chamber

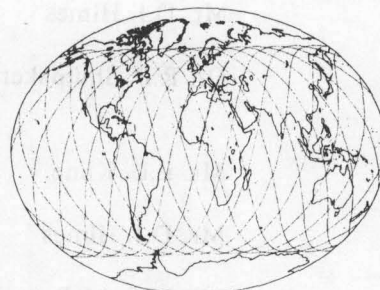

Automated Satellite Orbit Analysis

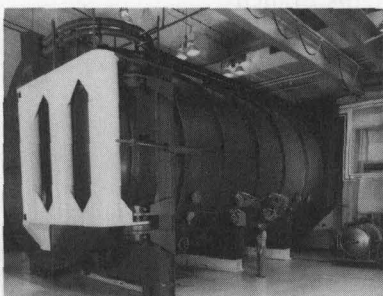

Thermal Vacuum Chamber

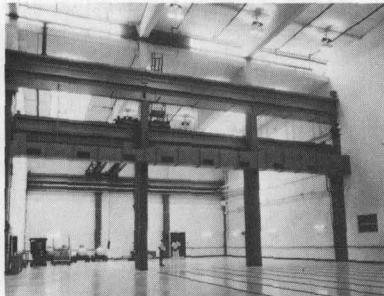

Spacecraft Assembly Facility

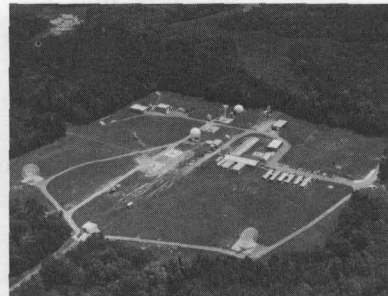

Satellite Tracking Facility, Blossom Point, MD



Mr. P. G. Wilhelm

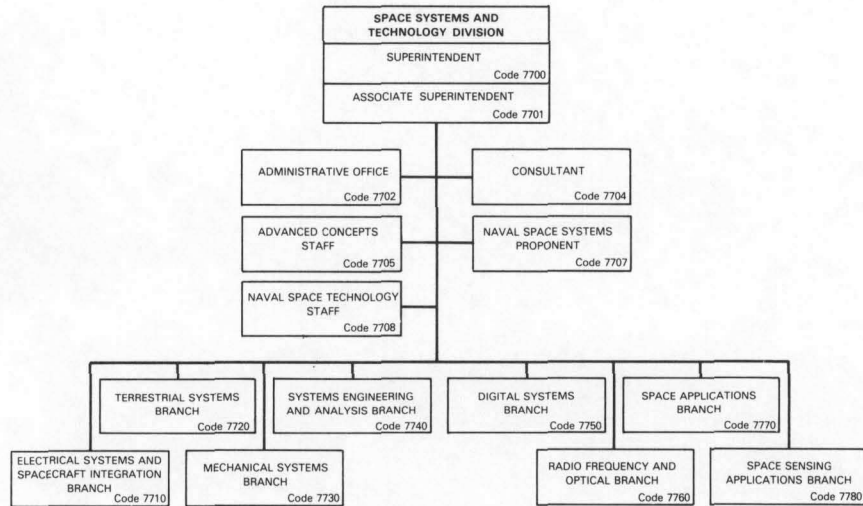

Basic Responsibilities

The Space Systems and Technology Division (SSTD) is the Navy's principal organization, or "lead laboratory," for space research. Activities extend from basic and applied research through advanced development in all areas of interest to the Navy space program. These activities include developing spacecraft, systems using these spacecraft, and ground command and control stations. Principal functions of the Division include understanding and clarifying requirements; recognizing and prosecuting promising research and development; analyzing and testing systems to quantify their capabilities; developing operational concepts that exploit new technical capabilities; system engineering to allocate design requirements to subsystems; and engineering development and initial operation to test and evaluate selected spacecraft subsystems and systems. The Division is a focal point and integrator for those divisions at NRL whose technologies are used in space systems. The SSTD is the core organization for the Naval Space Technology Center whose mission is to "preserve and enhance a strong space technology base and provide expert assistance in the development and acquisition of space systems which support naval missions." The Division also provides systems engineering and technical direction assistance to system acquisition managers of major space systems. In this role, technology transfer is a major goal and motivates a continuous search for new technologies and capabilities and the development of prototypes that demonstrate the integration of such technologies.

Key Personnel

Name	Title
Mr. P.G. Wilhelm	Superintendent
Mr. F.V. Hellrich	Associate Superintendent
Mrs. L.P. Wales	Administrative Officer
Mr. J.H. Trexler	Consultant
Mr. L.E. Hearton	Head, Advanced Concepts Staff
Vacant	Head, Navy Space Systems Proponent
Mr. P.G. Wilhelm*	Head, Navy Space Technology Staff
Mr. J.G. Winkler	Head, Electrical Systems & Spacecraft Integration Branch
Mr. T.W. Fisher	Head, Terrestrial Systems Branch
Mr. R.T. Beal	Head, Mechanical Systems Branch
Mr. L.M. Hammarstrom	Head, Systems Engineering & Analysis Branch
Mr. R.E. Eisenhauer	Head, Digital Systems Branch
Mr. F.E. Betz	Head, Radio Frequency & Optical Branch
Mr. R.L. Beard	Head, Space Applications Branch
Dr. V.E. Noble	Head, Space Sensing Branch

Personnel

Full-time civilian: 270

Point of contact: John Eisele, Code 7701.1, 767-3732

*Acting

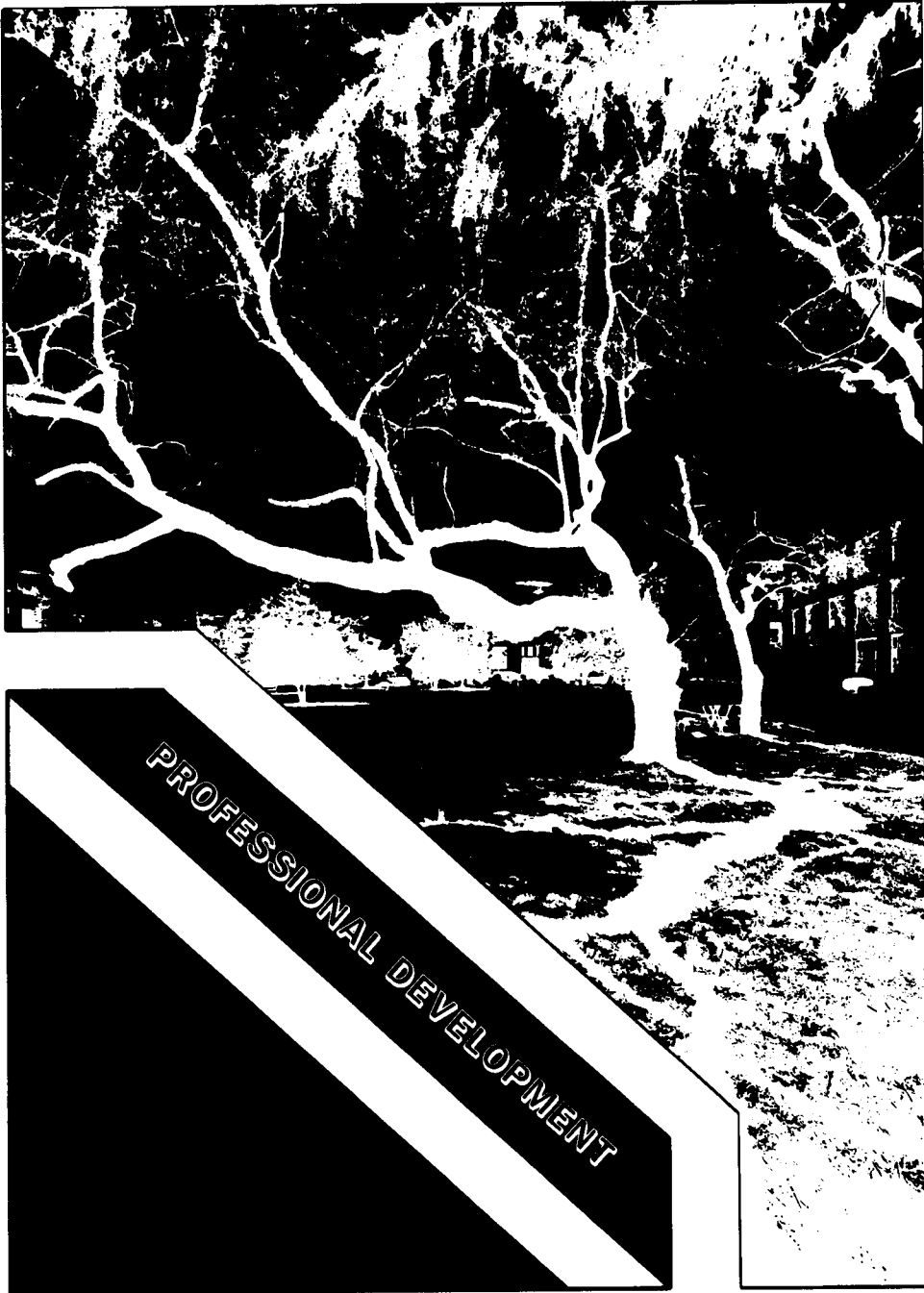

PROFESSIONAL DEVELOPMENT

PROFESSIONAL DEVELOPMENT

NRL has established many programs for the professional and personal development of its employees so they may better serve the needs of the Navy. These programs develop and retain talented people and keep them abreast of advanced technology and management skills. Graduate assistantships, fellowships, sabbatical study programs, cooperative education programs, individual college courses, and short courses for personal improvement contribute to professional development.

Programs also exist for non-NRL employees. These programs enhance Laboratory research efforts by providing means for non-NRL professionals to work at the Laboratory, thereby improving the interchange of ideas, meeting critical short-term technical requirements, and providing sources for new scientists and engineers. The programs include two-year graduate fellowships, faculty and professional interchanges, undergraduate work, and introducing gifted and talented high school students to the world of technology.

Programs for NRL Employees

During 1985, NRL employees participated in approximately 2700 individual training events. Many of these were presented as either video-taped or on-site instructed courses on diverse, technical subjects, management techniques, and enhancement of personal skills (efficient use of time, memory improvement, interpersonal communications, speed reading, etc.).

One common study procedure is for employees to work full time at the Laboratory and take job-related scientific courses at universities and schools in the Washington area. The training ranges from individual courses to full graduate and postgraduate programs. Tuition for job-related training is paid by NRL. Descriptions of formal programs offered by NRL follow.

Graduate Programs

- The **Advanced Graduate Research Program** (formerly the **Sabbatical Study Program**) enables selected professional employees to devote full time to research or course work in their own or a related field for one academic year at an institution of their choice without the loss of regular salary, leave, or fringe benefits. NRL pays all education, travel, and moving expenses for the individual and dependents. The program is open to paraprofessional (and above) employees who have completed six years of federal service, including four years at NRL.

- The **Edison Memorial Graduate Training Program** enables employees to pursue advanced studies in their fields at local universities. Eligible employees who are selected for participation in this program normally spend 24

hours of every work week in their studies. The criteria for eligibility include a minimum of one year of service at NRL, a bachelor's or master's degree in an appropriate field, and professional standing in keeping with the candidate's opportunities and experience.

- To be eligible for the **Select Graduate Student Program**, employees must have a college degree in an appropriate field and must have maintained at least a B average in undergraduate study. Accepted students devote a full academic year to graduate study. While attending school, they receive one half of their salary, and NRL pays for tuition, books, and laboratory expenses. During the summer, they work at the Laboratory and receive normal pay and fringe benefits.

- Research conducted at NRL may be used as **thesis material for an advanced degree**. This

original research is supervised by a qualified employee of NRL who is approved by the graduate school. The candidate should have completed the required course work and should have satisfied the language, residence, and other requirements of the graduate school from which the degree is sought. NRL provides space, research facilities, and supervision but leaves decisions on academic policy to the cooperating schools.

- The **Alfred P. Sloan Fellows Program** is designed for competent young executives whose job performance indicates senior management potential. The Sloan Fellows spend one year with the Massachusetts Institute of Technology faculty and with policymakers in industry and government. They study the theory and practice of effective and responsible management in a rapidly changing society.

- The **Education for Public Management Program** serves the training needs of individuals who are at midcareer and who have the talent to assume increasing responsibilities to direct agency programs and policies.

- The **Education Program for Federal Officials** exists for a small group of Federal employees who have demonstrated high competence and unusual promise. The Woodrow Wilson School of Princeton University has developed this program to enable selected midcareer officials to enlarge their knowledge in particular disciplines, to relate their fields of specialization to the broader concerns of government, and to sharpen their capacity for objective analysis of governmental problems.

- Federal Executive fellowships are available each year for employees to study in the **Brookings Institute Advanced Study Program**. In this program, the fellow is exposed to and participates in planning, developing, and conducting educational conferences on public policy issues for leaders in public and private life.

- The **Fellowship in Congressional Operations for Executives** provides an opportunity for some of the most promising young, technically oriented Federal executives to participate in a variety of assignments designed to develop their

knowledge and understanding of Congressional operations. These fellows share activities with other members of the Congressional Fellowship Program who come mainly from journalism, law, and college teaching.

- The **Maxwell Midcareer Development Program** of the Maxwell Graduate School of Citizenship and Public Affairs, Syracuse, New York, increases the managerial knowledge, ability, and skills of experienced Government officials who have been identified by their agencies as having potential for advancement to positions demanding progressively greater managerial and executive responsibilities.

- The **Practicing Engineer Advanced Study Program** of the M.I.T. Center for Advanced Engineering, Cambridge, Massachusetts, enables experienced engineers and applied scientists to work in-depth in technological areas pertinent to their professions, preparing for continued leadership in an age of unparalleled technological change.

- The **Science and Technology Fellowship Program**, a subsidiary of the Commerce Science Program, includes a variety of special events, lectures, seminars, visits, conferences, field trips, and interactions with key people from both the public and private sectors. Participants spend one week on Capitol Hill in an intensive, congressional orientation; they spend one week with the Brookings Institute, Science Policy Conference; and they take two week-long field trips for on-site inspection of scientific institutions and industrial complexes.

- The **Stanford-Sloan Program of the Graduate School of Business**, Stanford, California, gives exceptional young executives an opportunity to make an intensive study of new concepts and developments in business, to develop a top management perspective, and to broaden their intellectual horizons.

- The **Naval Postgraduate School (NPS)** in Monterey, California, provides advanced graduate study for selected Federal civilian employees who meet NPS academic requirements for the program in which they are interested, and whose employing agency is willing to act as sponsor.

Continuing Education

- Local colleges and universities offer **undergraduate courses** at NRL for employees to improve their skills and keep abreast of current developments in their fields. These courses are also available at many other DoD installations in the Washington, D.C. area.

- The Employee Development Branch at NRL offers to all employees **short courses** in certain program areas which are not available at local schools; laboratory employees may attend these courses at nongovernment facilities as well. Interagency courses in management, personnel, finance, supervisory development, clerical skills, and other areas are also available.

For further information on any of the above programs, contact the Employee Development Branch at 767-2956.

Growth Opportunities

NRL has several programs, professional society chapters, and informal clubs that enhance the professional growth of employees. Some of these are listed below.

- The **Career Counseling Center** helps employees to define short- and long-range career goals, to improve their job-seeking skills, and to deal with issues affecting job productivity.

- A chartered chapter of **Women in Science and Engineering (WISE)** has been established at NRL. Informal monthly luncheons and seminars are held to inform scientists and engineers of women's research at NRL and to provide an informal environment for practicing their presentations.

- **Sigma Xi**, the Scientific Research Society, encourages original investigation in pure

and applied science. The NRL chapter of approximately 450 active members meets nine times each year (from October to June) and sponsors a series of lectures on a wide range of pure and applied scientific topics of interest to both scientific and government communities. Each spring it sponsors an Edison Memorial Lecture at which a distinguished scientist, usually a Nobel Laureate, speaks on his or her research. The chapter also presents annual awards in pure and applied science.

- Any employee who is interested in developing effective self expression, listening, thinking, and leadership potential can join either of the two NRL chapters of **Toastmasters International**. Members of these clubs, who possess diverse career backgrounds and talents, meet three times a month to learn to communicate not by rules but by doing in an atmosphere of understanding and helpful fellowship.

- The **Federal Executive Professional Association (FEPA)** provides testimony, recommendations, and constructive criticism of the policies of the Executive Branch on existing proposed legislation and on regulatory actions. It also assists various advisory boards and commissions concerned with professional employee relations and benefits. The FEPA meets monthly for seminars given by NRL management.

Other programs that enhance the development of NRL employees include computer clubs (Edison, Atari, Edison Commodore, and the NRL-IBM PC) and the Amateur Radio Club. The Recreation Club offers many facilities to promote physical fitness. The Showboaters, a nonprofit drama group, presents live theater for the enjoyment of NRL and the community and produces two major productions each year, in addition to occasional performances at Laboratory functions and benefits for local charities.

Programs for Non-NRL Employees

Programs also exist for non-NRL employees. These programs encourage and support the participation of visiting scientists and engineers in research of interest to the Laboratory. Some of the programs may serve as stepping stones to federal careers in science and technology. Their objective is to enhance the quality of Laboratory research activities through working associations and interchanges with highly capable scientists and engineers and to provide opportunities for outside scientists and engineers to work in the Navy laboratory environment. Along with enhancing NRL research, these programs acquaint participants with Navy capabilities and concerns.

Recent Ph.D., Faculty Member, and College Graduate Programs

- The **National Research Council (NRC)/NRL Cooperative Research Associate-ship Program** selects associates who conduct research at NRL in their chosen fields in collaboration with NRL scientists and engineers. The tenure period is two years, and following their tenure, the Office of Naval Research offers the associate posttenure research grants tenable at an academic institution.

- The American Society for Engineering Education (ASEE) administers the **Office of Naval Technology (ONT) Postdoctoral Fellowship Program** to increase the involvement of highly trained scientists and engineers in disciplines to meet the evolving needs of naval technology. Appointments are for one year (renewable for a second and sometimes a third year). The appointments are competitive and are made jointly by ONT and ASEE.

- The American Society for Engineering Education also administers the **Navy/ASEE Summer Faculty Research Program** for university faculty members to work for 10 weeks with professional peers in participating Navy laboratories on research of mutual interest. NRL hosted 29 of these faculty participants in 1984.

- The **NRL/United States Naval Academy (USNA) Cooperative Program for Scientific Interchange** allows faculty members of the U.S. Naval Academy to participate in NRL research. This collaboration benefits the Academy by providing the opportunity for USNA faculty

members to work on research of a more practical or applied nature. In turn, NRL's research program is strengthened by the available scientific and engineering expertise of the USNA faculty.

- The **Office of Naval Research Graduate Fellowship Program** helps U.S. citizens obtain advanced training in disciplines of science and engineering critical to the U.S. Navy. The three-year program awards fellowships to recent outstanding graduates to support their study and research. This research must lead to doctoral degrees in specified disciplines such as electrical engineering, computer sciences, material sciences, applied physics, and ocean engineering. Award recipients are encouraged to continue their study and research in a Navy laboratory during the summer. Since the summer option began in 1983, 12 ONR graduate fellows have chosen NRL for their summer work.

Contact: Employee Development Branch, 767-2956

- The **United States Naval Academy Ensign Program** assigns Naval Academy graduates to NRL to work in areas of their own choosing and commensurate with their academic qualifications. These graduates provide invaluable summer research assistance while gaining experience in Navy R&D programs.

Professional Appointments

- **Faculty Member Appointments** use the special skills and abilities of university faculty members for short periods to fill scientific, engineering, professional, or analytical positions.

- **Consultants and experts** are employed because they are outstanding in their specialized fields or because they possess rare abilities but cannot normally be employed as regular full-time civil servants.

- **Intergovernmental Personnel Act Appointments** temporarily assign personnel from state or local governments or educational institutions to the Federal Government (or vice versa) to improve public services rendered by all levels of government.

Contact: Personnel Operations Branch, 767-3030

Undergraduate College Student Programs

Several programs are tailored to the undergraduate which provide employment and work experience in naval research. These are designed to attract applicants for professional employment in the Laboratory's shortage category positions such as engineers, physicists, mathematicians, and computer scientists. The student employment programs foster an understanding of NRL job opportunities among students and educational personnel so that educators can provide students who will meet NRL's occupational needs. The employment programs for college students include:

- **The Cooperative Education Program** alternates periods of work and study for students pursuing bachelor degrees in engineering, computer science, or the physical sciences. Several universities participate in this program.

- **The Federal Junior Fellowship Program** hires students entering college to be assistants to scientific, professional, or technical employees.

- **The Summer Employment Program** employs students for the summer in paraprofessional and technician positions in engineering, physical sciences, and computer sciences.

- **The Student Volunteer Program** helps students gain valuable experience by allowing them to voluntarily perform educationally related work at NRL.

- **The 1040-Hour Appointment** employs students on a halftime basis to assist in scientific work which is related to their academic program.

Contact: Personnel Operations Branch, 767-3030

High School Programs

- **The Gifted and Talented Internship Program** provides a meaningful, part-time employment experience for high school graduates who plan to pursue a bachelor's degree in engineering, computer science, or the physical sciences.

Contact: Personnel Operations Branch, 767-3030

- **The Summer Research Apprenticeship Program** employs high school juniors and seniors to serve for eight weeks as junior research associates. Under the direction of a mentor, students gain a better understanding of research, its opportunities, and challenges through participation in scientific programs. Criteria for eligibility are based on science and mathematics courses completed and grades achieved; scientific motivation, curiosity, and capacity for sustained hard work; a desire for a technical career; teacher recommendations; and ability and achievement test scores.

Contact: Employee Development Branch, 767-2956

Awards Received by Civilian Employees in FY 1985

Government	Number
The Alexander Von Humboldt Senior U.S. Scientist Award	1
Office of Personnel Management Director's Award for Improved Government Operations	9
Department of the Navy Commander's Award for Civilian Service	1
Department of the Navy Meritorious Civilian Service Award	8
Department of the Navy Captain Robert Dexter Conrad Award	1
E.O. Hulbert Award for Science	1
Naval Research Laboratory Space Systems Program Achievement Award	2
Commander's Award for Civilian Service to the U.S. Army	1
Nongovernment	
American Institute of Aeronautics and Astronautics	1
American Society for Metals George Kimball Burgess Memorial Award	1
Electromagnetic Compatibility Society Special Citation	1
Sigma Xi, The Scientific Research Society, Pure Science Award	1
Sigma Xi, The Scientific Research Society, Applied Science Award	1



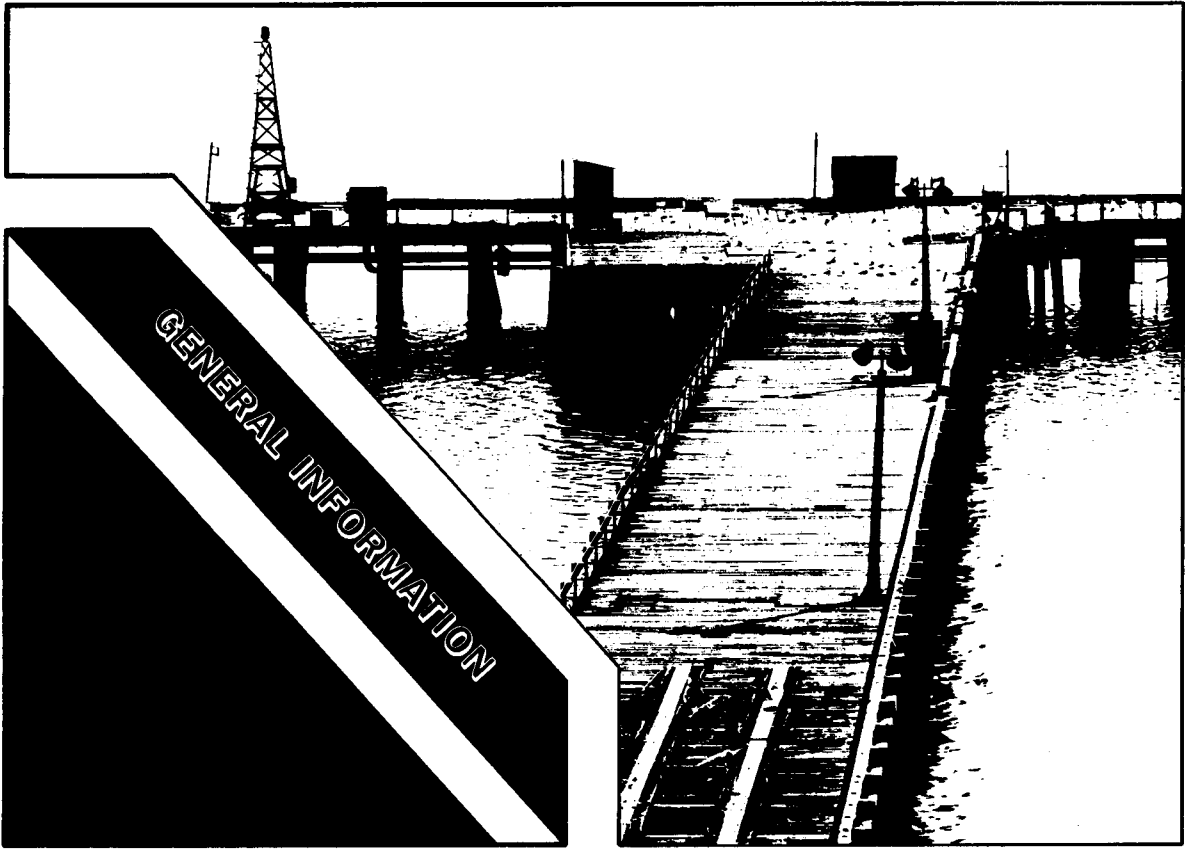

GENERAL INFORMATION

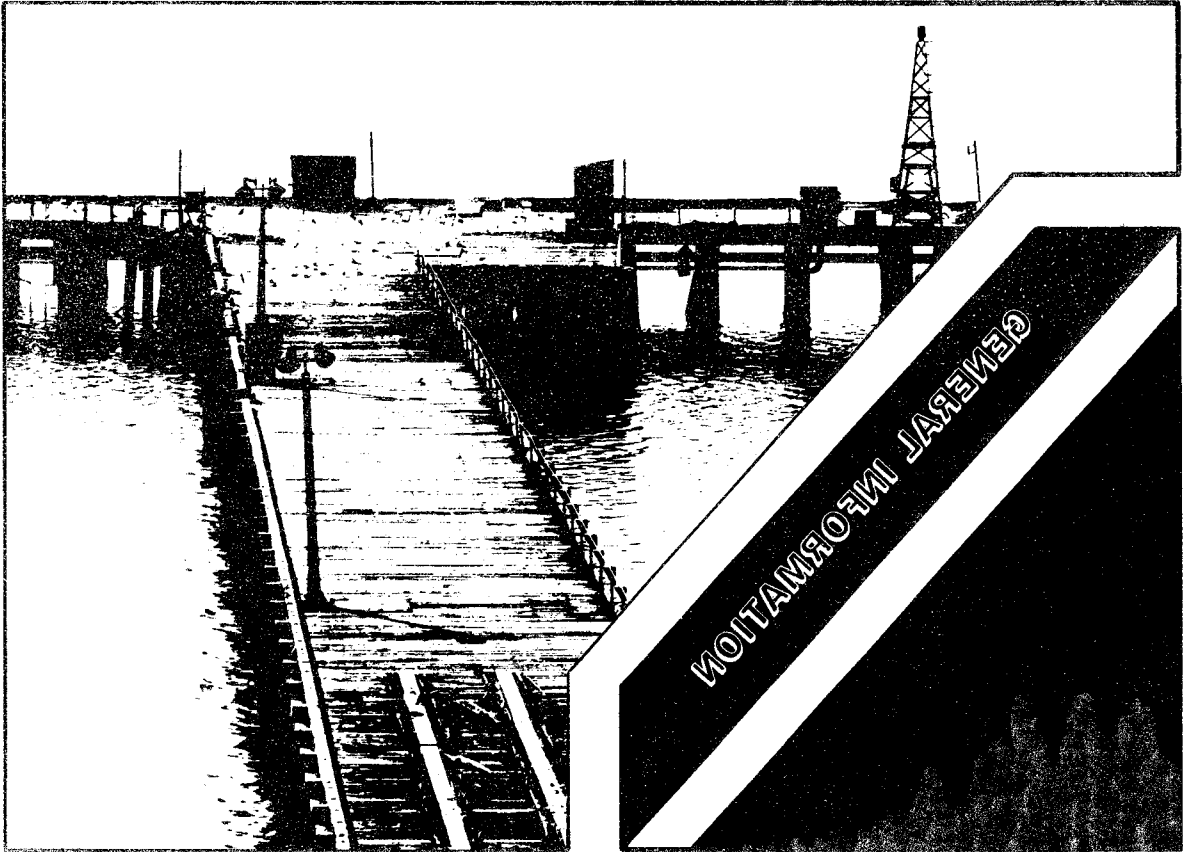

Location of NRL in the Capital Area

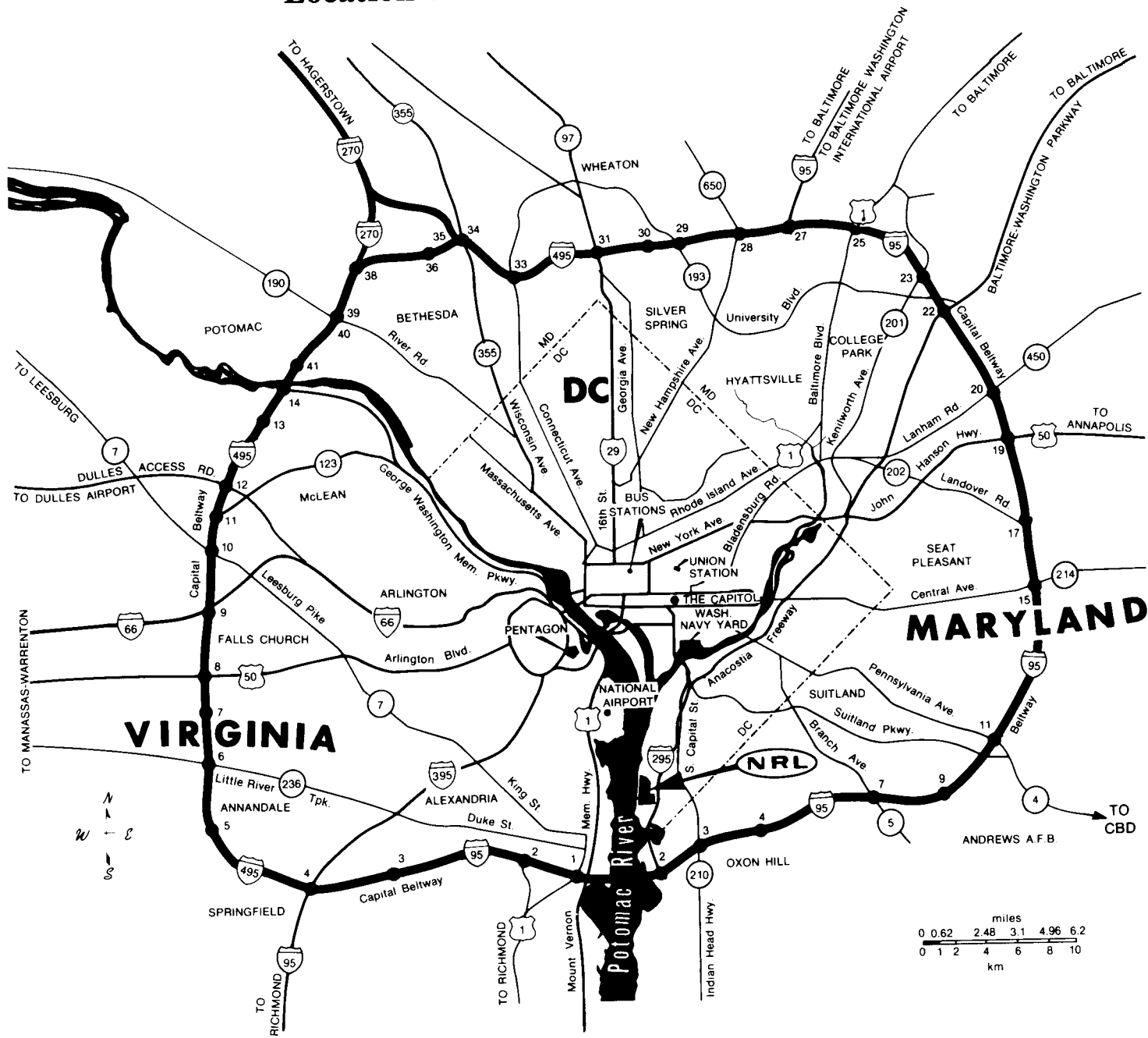

Location of Buildings at Main Site

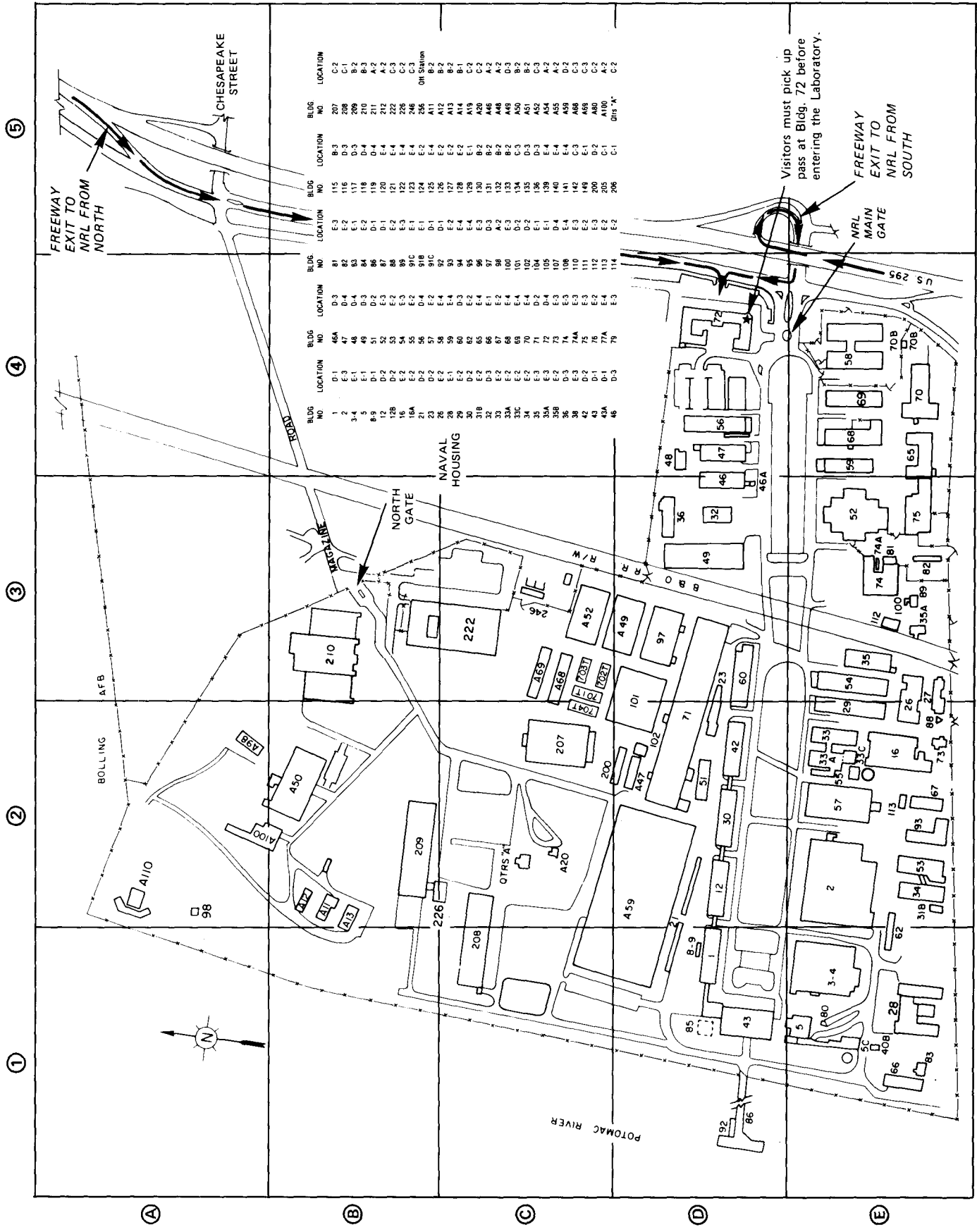

Location of Field Stations in Washington, D.C. Area

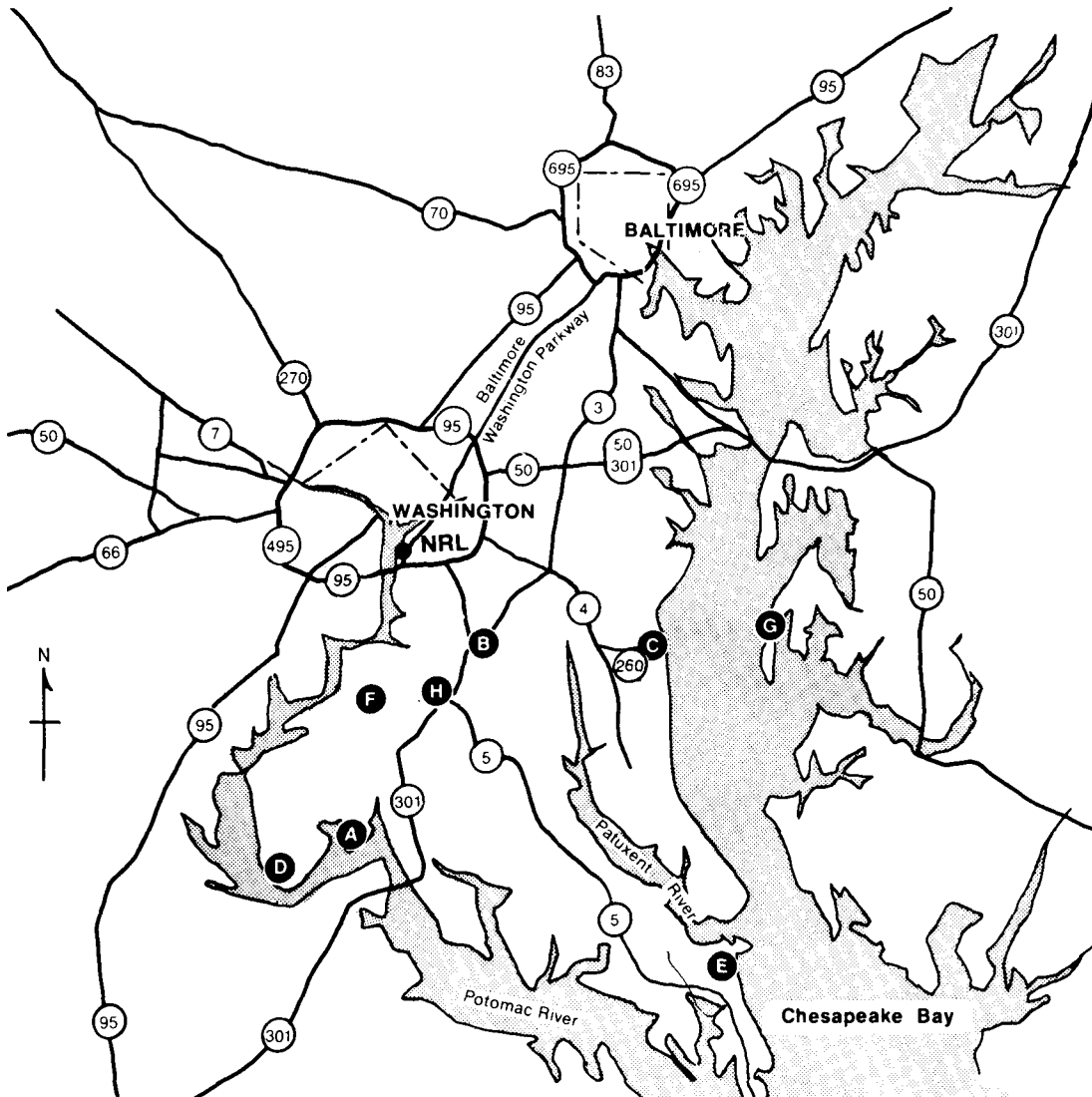

Approximate driving distance from NRL (in miles)

A — Blossom Pt., MD	40	E — Patuxent River Naval Station	64
B — Brandywine, MD	23	F — Pomonkey, MD	25
C — CBD (Chesapeake Bay Detachment) ..	40	G — Tilghman Island	110
D — Maryland Point Observatory	45	H — Waldorf Radio Site, MD	20

Chesapeake Bay Detachment

ACCESS ROUTES

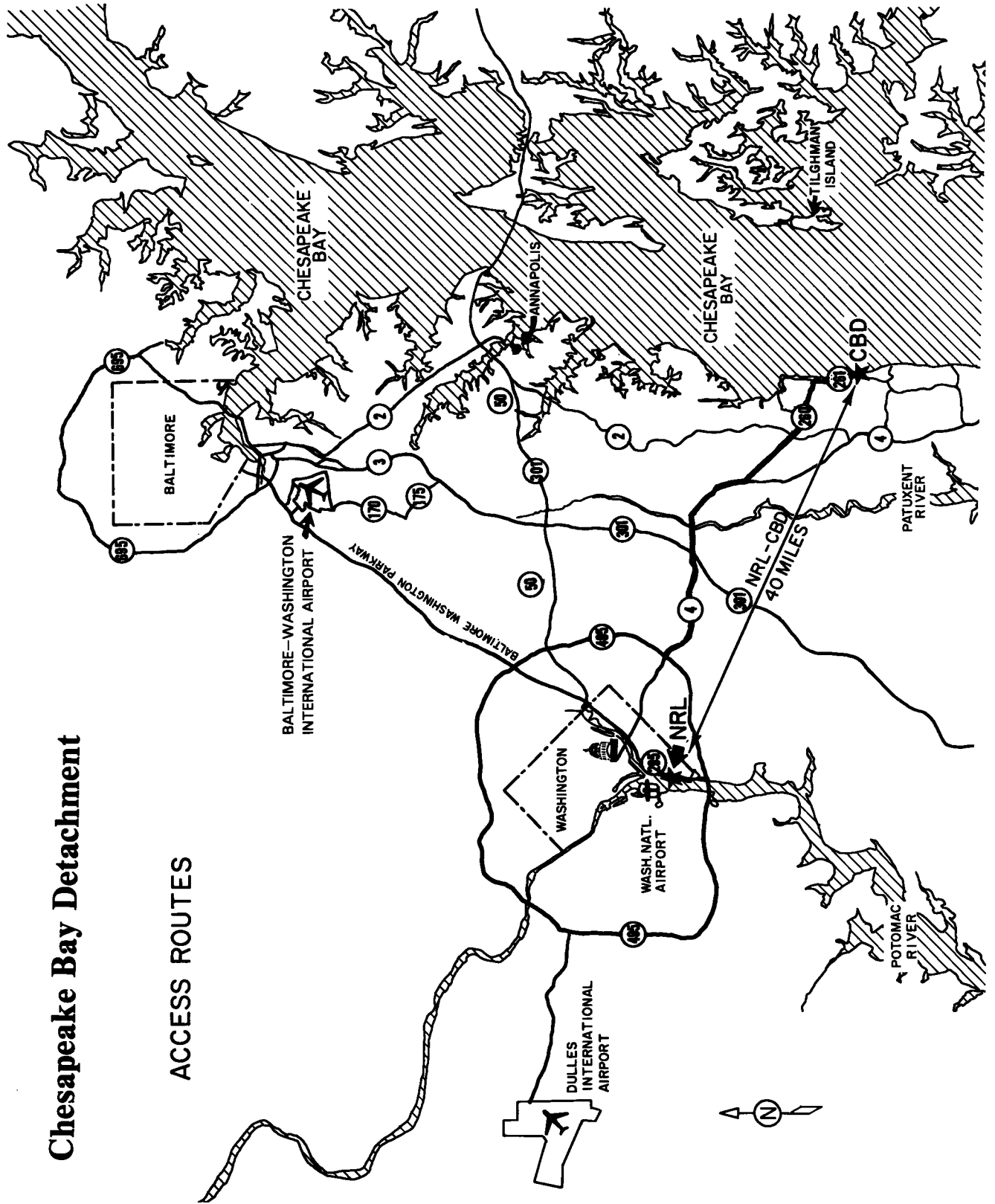

Underwater Sound Reference Detachment (Orlando, Florida)

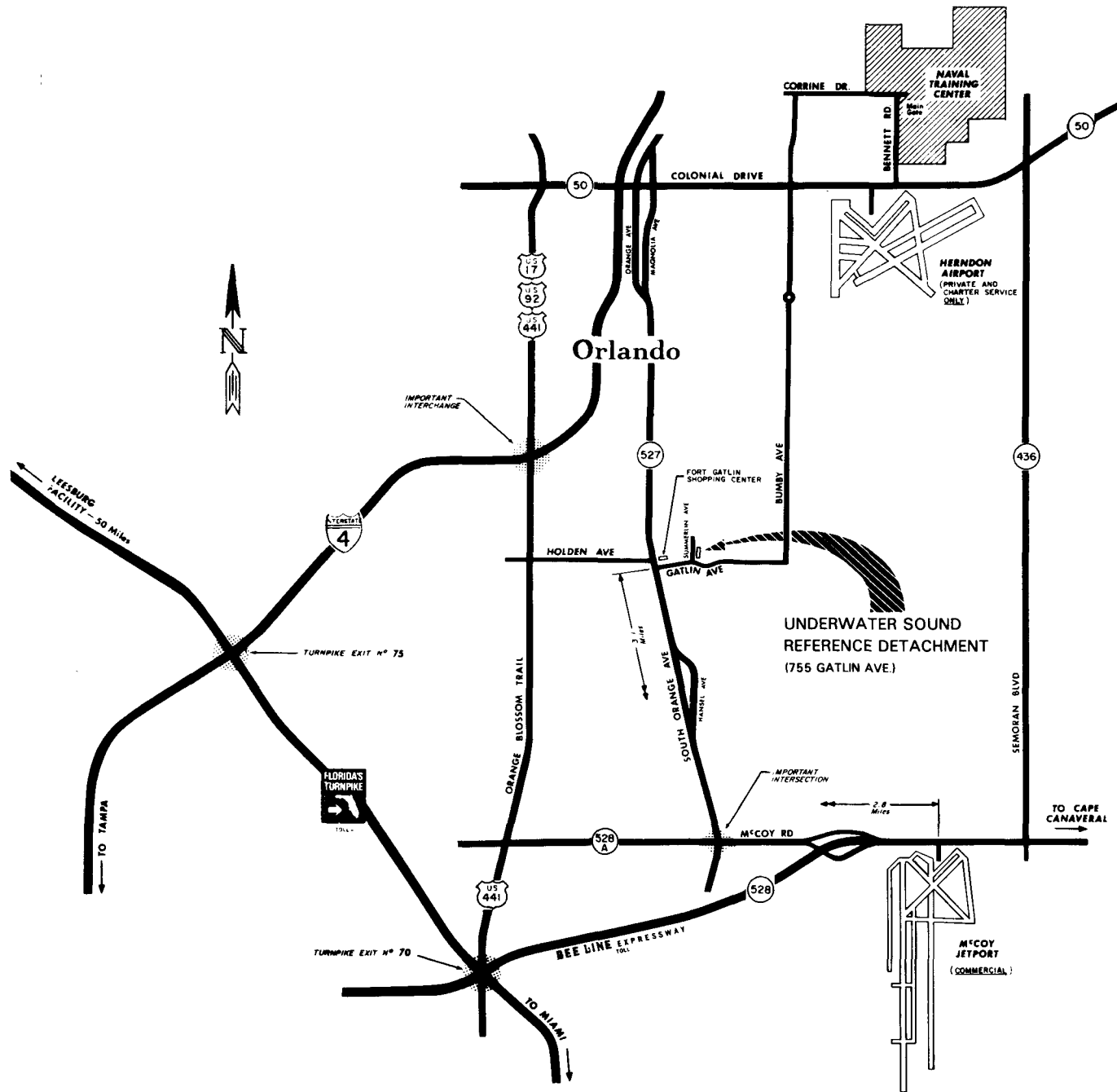

KEY PERSONNEL

Code			Ext.
EXECUTIVE DIRECTORATE			
1000	Commanding Officer	CAPT J.P. O'Donovan, USN	73403
1001	Director of Research	Dr. T. Coffey	73301
1803	DEEO Officer	Ms. S.A. Eaton	72486
1004	Scientific Consultant to the Dir. of Res.	Dr. P. Mange	73724
1005	Head, Office of Mgmt. and Admin.	Mrs. M. Oliver	73086
2610	Public Affairs Officer	Mr. J.W. Gately, Jr.	72541
1200	Chief Staff Officer	CAPT J.B. Morris, USN	73621
1220	Head, Security Branch	Mr. M.B. Ferguson	73048
1300	Comptroller	Mr. R.W. Steinbeck	73405
1800	Head, Civ. Pers. Div.	Mr. D.J. Blome	73421
1810	Personnel Operations	Mr. D.J. Blome	73421
TECHNICAL SERVICES DIRECTORATE			
2000	Assoc. Dir. Res. for Tech. Services	Mr. J.D. Brown	72879
2004	Patent Counsel ¹	Mr. S. Sheinbein*	73428
2010	Safety Officer	Mr. H.C. Kennedy, Jr.	72249
2020	Head, Administrative Services Office	Mrs. L.V. Dabney	73858
2300	Engineering Services Officer	LCDR M.L. Crouch, USN	72300
2400	Supply Officer	LCDR T. Lippert, USN	73446
2500	Public Works Officer	CDR J.P. Collins, USN ²	73371
2600	Head, Tech. Info. Div.	Mr. P. Imhof	73388
2700	Chesapeake Bay Detachment Officer (Tel. No. is Area Code 301-257-4002)	LT J.P. Dell, USN*	
2800	Head, Research Computation Division	Mr. R. Saenger	72751
GENERAL SCIENCE AND TECHNOLOGY DIRECTORATE			
4000	Assoc. Dir. Res. for General Sci. & Tech.	Dr. W.R. Ellis	73324
4040	Head, Lab. for Computational Physics	Dr. J.P. Boris	73055
4070	Head, Health Physics Group	Mr. J.N. Stone	72232
4100	Space Science Div. Supt.	Dr. H. Gursky	76343
4600	Condensed Matter & Radiation Sciences Div. Supt.	Dr. D.J. Nagel	72931
4700	Plasma Physics Div. Supt.	Dr. S. Ossakow	72723
SYSTEMS RESEARCH AND TECHNOLOGY DIRECTORATE			
5000	Assoc. Dir. Res. for Systems Res. & Tech.	Mr. R.R. Rojas	73294
5100	Acoustics Div. Supt.	Dr. D.L. Bradley	73482
5300	Radar Div. Supt.	Dr. M.I. Skolnik	72936
5700	Tactical Elec. Warfare Div. Supt.	Dr. J.A. Montgomery	76278
5800	Marine Technology Div. Supt.	Dr. R.T. Swim	73314
5900	Underwater Sound Reference Det. Supt. (Tel. No. is Area Code 305-859-5120)	Dr. J.E. Blue	
MATERIAL SCIENCE AND COMPONENT TECHNOLOGY DIRECTORATE			
6000	Assoc. Dir. Res. for Material Science & Component Tech.	Vacant	73566
6030	Head, Lab. for Structure of Matter	Dr. J. Karle	72665
6100	Chemistry Div. Supt.	Dr. W.M. Tolles	73026
6300	Mat. Sci. & Tech. Div. Supt.	Dr. B.B. Rath	72926
6500	Optical Sciences Div. Supt.	Dr. T.G. Giallorenzi	73171
6800	Electronics Tech. Div. Supt.	Dr. G.M. Borsuk	73525
SPACE AND COMMUNICATIONS TECHNOLOGY DIRECTORATE			
7000	Assoc. Dir. Res. for Space & Comm. Tech.	Dr. B. Wald	72964
7500	Information Technology Div. Supt.	Dr. J.R. Davis	72903
7700	Space Systems and Technology Div. Supt.	Mr. P.G. Wilhelm	76547

*Acting

¹Patent Counsel to be transferred to Code 1200 July/August 1986

²CDR Collins transferred 5/23/86. New PWO CDR T.R. Rampe

MISCELLANEOUS

Mailing Address: Naval Research Laboratory
4555 Overlook Avenue, S.W.
Washington, DC 20375-5000

Direct-in Dialing	(202) 76-(Ext.)
Information, Naval Research Laboratory	73200
AUTOVON, Incoming 29-(Ext.)	
Emergency, Duty Officer (outside working hours)	73523
Medical Clinic	73592

1986 FACT BOOK STAFF

Peter Imhof, Head, Technical Information Division

Maureen L. Long, Staff Editor and Publication Coordinator

Leona Jackson, cover and graphic designs

Michael A. Savell, design photography

The cooperation and able assistance of the staffs of the Computerized Technical Composition section, the Graphic Services section, and the Photographic/Illustration Branch are acknowledged and appreciated.