



AFRL-RI-RS-TR-2013-099

ELECTRO-OPTICAL AND OPTICAL COMPONENTS FOR PROCESSOR TO PROCESSOR INTERCONNECTS

APRIL 2013

FINAL TECHNICAL REPORT

APPROVED FOR PUBLIC RELEASE; DISTRIBUTION UNLIMITED

STINFO COPY

**AIR FORCE RESEARCH LABORATORY
INFORMATION DIRECTORATE**

■ AIR FORCE MATERIEL COMMAND

■ UNITED STATES AIR FORCE

■ ROME, NY 13441

NOTICE AND SIGNATURE PAGE

Using Government drawings, specifications, or other data included in this document for any purpose other than Government procurement does not in any way obligate the U.S. Government. The fact that the Government formulated or supplied the drawings, specifications, or other data does not license the holder or any other person or corporation; or convey any rights or permission to manufacture, use, or sell any patented invention that may relate to them.

This report was cleared for public release by the 88th ABW, Wright-Patterson AFB Public Affairs Office and is available to the general public, including foreign nationals. Copies may be obtained from the Defense Technical Information Center (DTIC) (<http://www.dtic.mil>).

AFRL-RI-RS-TR-2013-099 HAS BEEN REVIEWED AND IS APPROVED FOR PUBLICATION IN ACCORDANCE WITH ASSIGNED DISTRIBUTION STATEMENT.

FOR THE DIRECTOR:

/ S /

STEVEN T. JOHNS, Chief
Trusted Systems Branch
Computing & Communications Division

/ S /

RICHARD MICHALAK
Acting Tech Advisor, Computing &
Communications Division
Information Directorate

This report is published in the interest of scientific and technical information exchange, and its publication does not constitute the Government's approval or disapproval of its ideas or findings.

REPORT DOCUMENTATION PAGE*Form Approved*
OMB No. 0704-0188

The public reporting burden for this collection of information is estimated to average 1 hour per response, including the time for reviewing instructions, searching existing data sources, gathering and maintaining the data needed, and completing and reviewing the collection of information. Send comments regarding this burden estimate or any other aspect of this collection of information, including suggestions for reducing this burden, to Department of Defense, Washington Headquarters Services, Directorate for Information Operations and Reports (0704-0188), 1215 Jefferson Davis Highway, Suite 1204, Arlington, VA 22202-4302. Respondents should be aware that notwithstanding any other provision of law, no person shall be subject to any penalty for failing to comply with a collection of information if it does not display a currently valid OMB control number.

PLEASE DO NOT RETURN YOUR FORM TO THE ABOVE ADDRESS.

1. REPORT DATE (DD-MM-YYYY) APRIL 2013			2. REPORT TYPE FINAL TECHNICAL REPORT		3. DATES COVERED (From - To) NOV 2010 – NOV 2012	
4. TITLE AND SUBTITLE ELECTRO-OPTICAL AND OPTICAL COMPONENTS FOR PROCESSOR TO PROCESSOR INTERCONNECTS					5a. CONTRACT NUMBER IN HOUSE	
					5b. GRANT NUMBER N/A	
					5c. PROGRAM ELEMENT NUMBER 61102F	
6. AUTHOR(S) Joseph Osman, Reinhard Erdmann, Michael Fanto, Corey Peters					5d. PROJECT NUMBER T10P	
					5e. TASK NUMBER IN	
					5f. WORK UNIT NUMBER HO	
7. PERFORMING ORGANIZATION NAME(S) AND ADDRESS(ES) Air Force Research Laboratory/Information Directorate Rome Research Site/RITA 525 Brooks Road Rome NY 13441-4505					8. PERFORMING ORGANIZATION REPORT NUMBER N/A	
9. SPONSORING/MONITORING AGENCY NAME(S) AND ADDRESS(ES) Air Force Research Laboratory/Information Directorate Rome Research Site/RITA 525 Brooks Road Rome NY 13441-4505					10. SPONSOR/MONITOR'S ACRONYM(S) AFRL/RI	
					11. SPONSORING/MONITORING AGENCY REPORT NUMBER AFRL-RI-RS-TR-2013-099	
12. DISTRIBUTION AVAILABILITY STATEMENT Approved for Public Release; Distribution Unlimited. PA# 88ABW-2013-1486 Date Cleared: 27 Mar 13						
13. SUPPLEMENTARY NOTES						
14. ABSTRACT We began building a Hong-Ou-Mandel interferometer based entanglement verification system. This will allow us to detect changes in entanglement due to imperfections in interconnect media and components. Members of our quantum computing team were very helpful and this gave our team an opportunity to learn the experimental techniques used in quantum optics. We began to develop hyper-entanglement methods to allow for entanglement swapping and sacrificial pairs for destructive testing of entanglement. Hyper-entanglement is the ability to encode information in the multiple degrees of freedom of a qubit. These degrees of freedom can include polarization, spatial, OAM, momentum and spectral. Some development of a technique for "photons on demand" was done for the case of sources for entanglement characterization systems. The literature in the area of quantum memory and quantum processor to memory I/O was searched and read in order to give an understanding of future possible areas of development in this area. Plans for further collaboration as part of a new interdirectorate LRIR were made.						
15. SUBJECT TERMS Quantum Optics, Polarization, Hyper-Entanglement, Photons on Demand						
16. SECURITY CLASSIFICATION OF:			17. LIMITATION OF ABSTRACT	18. NUMBER OF PAGES	19a. NAME OF RESPONSIBLE PERSON	
a. REPORT	b. ABSTRACT	c. THIS PAGE			JOSEPH OSMAN	
U	U	U	UU	24	19b. TELEPHONE NUMBER (Include area code) N/A	

Table of Contents

List of Figures.....	ii
1 PROGRAM SUMMARY	1
2 PROGRAM INTRODUCTION.....	1
2.1 Current research	1
2.2 Quantum computing architecture target - Cluster State Computing.....	2
2.3 Quantum computing architecture target - Distributed Quantum Computing.....	2
2.4 Our research direction	3
ENTANGLEMENT VERIFICATION SYSTEM – THE HONG-OU-MANDEL INTERFEROMETER.....	3
3 SUMMARY	3
4 INTRODUCTION.....	3
5 METHODS, ASSUMPTIONS, AND PROCEDURES	4
6 RESULTS AND DISCUSSION	4
7 CONCLUSIONS.....	5
QUANTUM WAVELENGTH HYPERENTANGLEMENT	5
8 SUMMARY.....	5
9 INTRODUCTION.....	5
10 METHODS, ASSUMPTIONS, AND PROCEDURES.....	5
11 RESULTS AND DISCUSSION	5
12 CONCLUSIONS.....	6
TIME BIN ENTANGLEMENT	6
13 SUMMARY.....	6
14 INTRODUCTION	6
15 METHODS, ASSUMPTIONS, AND PROCEDURES.....	6
16 RESULTS AND DISCUSSION	7
17 CONCLUSIONS.....	7
OTHER TYPES OF INTERCONNECTS NEEDED FOR QUANTUM COMPUTING	7
18 SUMMARY.....	7
19 INTRODUCTION	7
20 METHODS, ASSUMPTIONS, AND PROCEDURES.....	7
20.1 Memory to Processor I/O	7

20.2	Quantum Repeaters	8
20.3	Optical Interconnects for the Integrated Optics Quantum CoProcessor (IOQCP) Chip..	8
21	RESULTS AND DISCUSSION	8
22	CONCLUSIONS.....	9
23	PROGRAM SUMMARY	9
24	PROGRAM CONCLUSIONS.....	9
25	REFERENCES	10
26	APPENDIX.....	12

LIST OF FIGURES

Figure 1.	HOMI based entanglement characterization system.....	4
Figure 2.	HOMI-based system modified for hyperentanglement use.....	5

1 PROGRAM SUMMARY

The purpose of this in-house program was to develop techniques, architectures and systems in optical information science to support AF programs in advanced computer concepts and signal processing. We concentrated on bringing optical interconnects¹ into advanced architectures as a way of reducing latency in interprocessor communications, especially at the memory level.

More specifically, we sought to develop optical interconnects to support Air Force programs that pursue quantum computational methods. After discussions with our in-house quantum computing team we selected as an initial metric the transfer of a 4-qubit state between two separate quantum circuits. We sought to build upon past AFRL-sponsored theoretical work on distributed quantum computing and investigate the use of optical interconnects in a cluster state and/or a distributed quantum computing (DQC) approach to building a quantum computer in hardware.

2 PROGRAM INTRODUCTION

2.1 Current research

DiVencenzo's five (plus two) requirements for the implementation of quantum computation are²

- A scalable physical system with well characterized qubits.
- The ability to initialize the state of the qubits to a simple fiducial state, such as $|000\dots\rangle$.
- Long relevant decoherence times, much longer than the gate operation time.
- A "universal" set of quantum gates.
- A qubit-specific measurement capability.

Two additional criteria focus on moving quantum information between two different quantum computers. A viable quantum communications technology must have:

- The ability to interconvert stationary and flying qubits.
- The ability faithfully to transmit flying qubits between specified locations.

Communication within or between quantum computers can take the form of passing classical bits as intermediate results of computation or control bits for quantum gates, but quantum computing also has the ability to communicate with quantum states. Communication with pure quantum states has the problem that the states cannot be measured to determine where they should be routed. Measurement collapses the state, so specially prepared entangled states (cat states) must be used as "flying qubits" for communication. These states were first proposed in 1997 by Grover³ and Cleve and Buhrman⁴. They were further developed under an AFRL grant in 2004 by Lomonaco and Kauffman⁵ and by a few others as well. Quantum computing even has the ability to use these states to form virtual gates with separated components⁶. For instance, one shared entangled pair and two classical bits are necessary and sufficient to implement a non-local CNOT gate⁷.

However, these quantum states are fragile and prone to error and cannot go far without collecting error, which is called decoherence in the optical computing community. Not only must this decoherence time be longer than the time it takes to go through a gate, but in practice it must be longer than it takes for a computation. Because the use of constructive and destructive

interference is essential to quantum computation, and the computational pathways inside the system split and only recombine at the end, phase decoherence will occur unless the quantum system is isolated from its environment⁸.

These quantum cat states are usually specially encoded in quantum error correction (QEC) codes used in conjunction with fault-tolerant (FT) methods⁹. A single qubit may be encoded in five to nine qubits for error correction with a seven-bit Steane code¹⁰ being most common. These QEC/FT schemes are technology dependent so the designer must take this into account when mixing technologies in a system. For instance, linear optics quantum computation (LOQC) often uses optical erasure codes quite different than the ECCs used in other technologies¹¹. The cat states are either constantly being measured and/or purified or additional ancillae qubits must be added to the cat states.

Any gates in the system should be fault tolerant for these cat states. Scalability also requires that the layout of a candidate multi-qubit quantum gates is such that an additional qubit for communication can be addressed as well¹². One promising candidate technology for gates is the single-photon transistor for cat-states developed by the Lukin group at Harvard¹³.

2.2 Quantum computing architecture target - Cluster State Computing

Traditional quantum gate circuits are resource-inefficient. An alternative computing paradigm, quantum cluster state computing^{14,15}, is relatively resource-efficient by comparison. A typical cluster state is a multi-qubit highly entangled state pattern, formed by using Hadamard gates to form qubit superposition states which interact with some neighboring qubits via cPHASE gates. Particular quantum calculations are carried out by performing only single qubit measurements on selected qubits. The Pauli results are fed-forward to determine the proper measurement basis to be used further on down the chain. Cluster state computing reduces the required resources dramatically. However, even cluster state computing still requires significant numbers of qubits and gates for realistic problems. And the larger the cluster, the greater the decoherence problem.

2.3 Quantum computing architecture target - Distributed Quantum Computing

The way out of this difficulty is to use a distributed computing architecture, employing modern integrated circuit technology, shrinking qubit size increasing the density of qubits and gates, to build quantum subsystems. The subsystems are interconnected using quantum and / or classical communication channels.

Current quantum optical approaches under investigation employ large numbers of quantum gates, e.g. on an optical table, interacting to form quantum circuits performing some desired function. Scaling such circuits to address problems involving greater numbers of variables becomes a severe resource problem, with associated alignment problems of increasing difficulty. A DQC approach involves interconnecting smaller quantum circuits with either entangled photon quantum channels or classical communication busses to perform the same quantum functions. The reduction in quantum circuit complexity at each quantum node makes the overall scheme more practical in theory. And, decoherence problems which typically plague quantum systems are reduced using such a scheme. AFRL has sponsored theoretical work on distributed quantum computing¹⁶. Our quantum computing team planned research on small optical quantum "sub-processor" circuits interconnected with classical channels to test the overall concept in

simulation and then in hardware. Techniques to translate existing quantum algorithms into efficient distributed algorithms which would then be run on the DQC would also be investigated.

This approach is a potential fast track to scalable quantum computing in the relative near term. If successful, this DQC effort would allow the promise of quantum computing to be realized in AF applications years sooner than approaches using integrated non-distributed techniques. The development of a practical optical quantum computing technology will impact virtually all AF sensing, security, communication and computing systems. Quantum computers with unprecedented levels of security and computational capability, promise dramatically decreased computation times for complex AF problems such as faster optimization of complex AF C2 systems, ultra-high-speed signal and image processing, and fast informational data base searches.

2.4 Our research direction

We wanted to concentrate on techniques to launch and receive entangled photons with and without necessary ancilla bits. We hoped to set up several small optical quantum optical interconnect circuits on an optical table using existing in-house methods of generating entangled photons to test the overall concept in hardware.

ENTANGLEMENT VERIFICATION SYSTEM – THE HONG-OU-MANDEL INTERFEROMETER

3 SUMMARY

We began building a Hong-Ou-Mandel interferometer based entanglement verification system. This will allow us to detect changes in entanglement due to imperfections in interconnect media and components. Members of our quantum computing team were very helpful and this gave our team an opportunity to learn the experimental techniques used in quantum optics.

4 INTRODUCTION

The major difference in interconnects for quantum computing as compared with other advanced computer architectures is that in quantum computing entangled photons must be moved/ported and routed throughout the interconnect without destroying the quantum entanglement. There are no commercial test systems capable of measuring the degree or quality of entanglement. However, there is a lot of work on single-photon sources. So far development of single-photon sources is the main experimental area of emphasis here in RI. Techniques for testing of these single-photon sources have been developed¹⁷ and we can use these techniques to characterize entanglement at other points in a quantum system. One of these techniques is based on the experiment of Hanbury Brown and Twiss¹⁸ (MBT) and measures $g^{(2)}$ the normalized second order quantum correlation function. Another is based on the experiment of Hong, Ou and Mandel¹⁹ and is known as a Hong-Ou-Mandel Interferometer (HOMI).

Our approach was to modify a HOMI to use as an entanglement verification system. We used the work of Santori²⁰ as a guide.

5 METHODS, ASSUMPTIONS, AND PROCEDURES

A Hong-Ou-Mandel interferometer was constructed using type-II parametric down conversion. The apparatus included an entangled photon generator. The design allowed for improved coincidence via focusing into (and out of) the BBO crystal. The standard type-II entangled pair setup was used in conjunction with two orthogonal arms of an interferometer that fed in to a pair of avalanche photodiodes. The type-II down converted pairs were aligned such that they exited the nonlinear β -barium-borate (BBO) collinearly. To obtain perfect interference fringes the wave packets of the signal and idler (down converted pair) needed to be overlapped. There is walk-off due to the birefringence of the BBO so the wave packets exit the crystal at different times. A Babinet-Soleil-like compensator for birefringence compensation was custom built in the form of two quartz wedges with their optic axes parallel to each other. This allowed the signal and idler wave packets to be brought back together. With these wave packets perfectly overlapping, the photons will interfere on the back side of this test bed. The apparatus was constructed on a mobile breadboard with the idea that it can be readily moved to analyze entanglement quality for various interconnect devices.

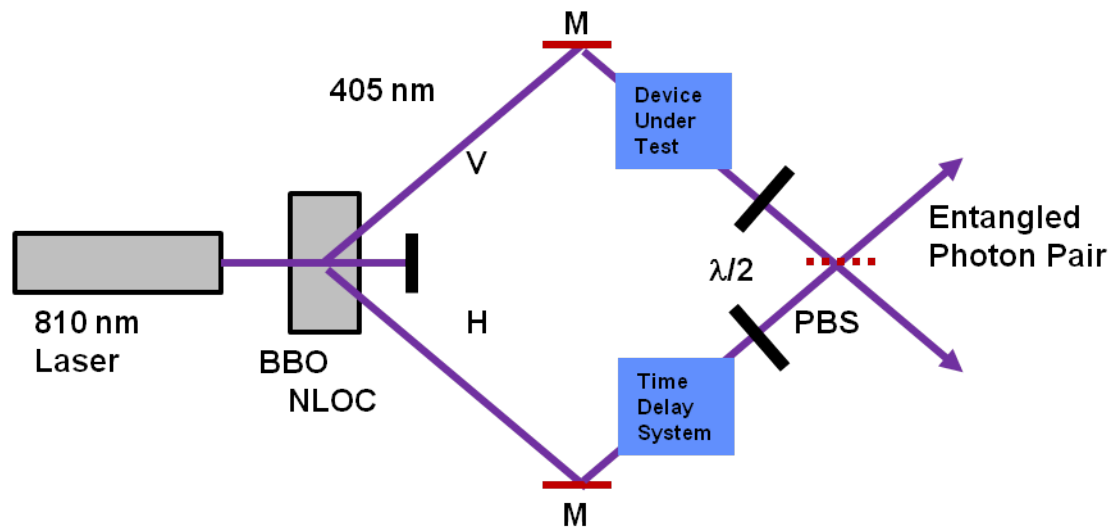

Figure 1. HOMI based entanglement characterization system

We are grateful for the following collaborations:

Initial Setup and consultation - Dr. Reinhard Erdmann, Michael Fanto (Rome Quantum Computing Team), Dr. Enrique Galvez (Colgate U).

6 RESULTS AND DISCUSSION

Initial tests were less than promising. We suspect the PBS's were cut for a different wavelength as they did not yield equal output when tested with a separate diode laser at the appropriate wavelength.

7 CONCLUSIONS

This will also be useful for the testing of parametric sources²¹ as well as developmental “photons on demand” such as quantum dot or diamond vacancy based sources.

QUANTUM WAVELENGTH HYPERENTANGLEMENT

8 SUMMARY

We desired to develop hyper-entanglement methods to allow for entanglement swapping and sacrificial pairs for destructive testing of entanglement. Hyper-entanglement is the ability to encode information in the multiple degrees of freedom of a qubit. These degrees of freedom can include polarization, spatial, OAM (Orbital Angular Momentum), momentum and spectral.

9 INTRODUCTION

The test setup includes adaptation for various entangled photon sources, and can be modified to incorporate certain forms of hyper-entanglement. These methods would allow more Q-bits to be realized for each photon to enable efficient scaling. Entanglement swapping can also be realized in a dual version of this HOMI design, to enable the transfer of entangled data between several sources, possibly also of different types. Use of ancillary photons and non-demolition techniques can mitigate the constraints posed by the quantum no-cloning theorem, and also minimize the number of photons that must be destructively measured in the course of the computational system, or interconnect, operation.

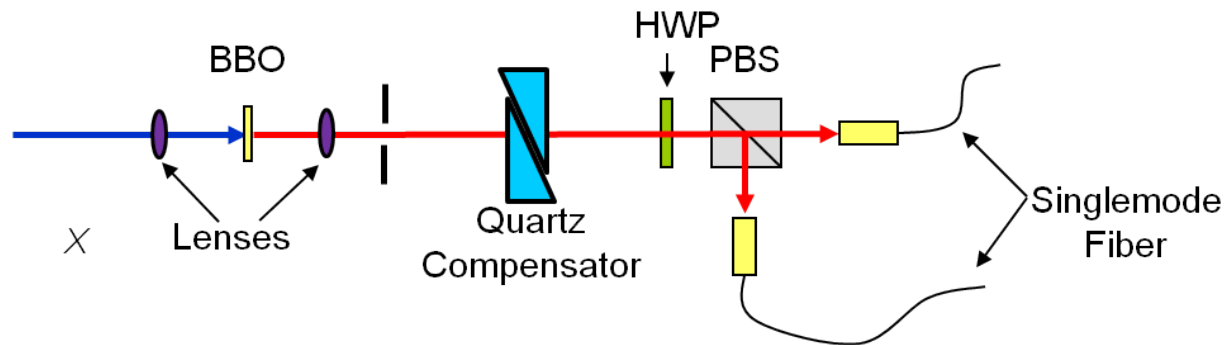

Figure 2. HOMI-based system modified for hyperentanglement use

10 METHODS, ASSUMPTIONS, AND PROCEDURES

See Appendix A – “Quantum Wavelength Hyperentanglement” by Henry Zmuda. Prof. Zmuda contributed to this in-house research project while working at the Information Directorate under the Visiting Faculty Summer Research Program.

11 RESULTS AND DISCUSSION

See Appendix A – “Quantum Wavelength Hyperentanglement” by Henry Zmuda.

12 CONCLUSIONS

We have begun initial investigations of photon wavelength (frequency/energy) hyperentanglement as a means of increasing the number of entangled photon states. This work represents an initial study for future research that could lead to a potential breakthrough for both quantum computation and quantum communication applications.

Our future hyper-entanglement research goals are:

- polarization + spatial entanglement.
- orbital angular momentum + spectral entanglement.

TIME BIN ENTANGLEMENT

13 SUMMARY

Some development of a technique for “photons on demand” was done for the case of sources for entanglement characterization systems.

14 INTRODUCTION

The source used in our HOMI-based entanglement characterization system shares the problem of all single-photon sources in that it produces a sparse number of photon pairs and does not produce them in a deterministic manner. Research in solving this problem is undergoing at several universities. The emphasis is on sources for the quantum computing systems themselves, which have somewhat different requirements than a source in a characterization system. The goal of these efforts is to deliver single photons if not "on demand" then at least with a high probability.

15 METHODS, ASSUMPTIONS, AND PROCEDURES

We have an interdirectorate AFOSR LRIR (Laboratory Research Initiation Request) with Dr. Atilla Szep of the Sensors Directorate which includes strong interaction with Dirk Englund of Columbia University and MIT, who is an AFOSR YIP (Young Investigator Research Program) winner. The goal of this program is to build an Integrated Optics Quantum CoProcessor (IOQCP) Chip. As part of this interaction, we discussed including SOI (Silicon-on-Insulator) slot waveguide/polymer optical switches using cross-Kerr modulation for time-bin entanglement in our plans. This had been suggested in the paper “Efficient generation of single and entangled photons on a silicon photonic chip” from Englund's group²². These switches are for time-bin entanglement in which some number N of SPDC (Spontaneous Parametric Down Conversion) sources are spatially or temporally multiplexed such that there is a fairly constant availability of entangled photon pairs. One advantage of this “photon gun” is that the pair production rate of each of the N SPDC sources can be kept low enough that the probability of any generating more than one pair is small. The use of a “heralding” idler photon that can be detected and used to signal the production of a pair is key as it allows a control signal for pair routing. This is called “feed-forward” in quantum communication papers.

16 RESULTS AND DISCUSSION

However, at the DARPA QuEST (Quantum Entanglement Science and Technology) PI Review MIT reported on problems with cross-Kerr modulation and quantum photons. Osman discussed this with the professor and graduate student. We will have to take this into account when we design new switches.

A source in a quantum computer needs to output a continuous stream of photons but a source in a characterization system only needs photons when it is actually in test mode and storing photons when not needed in a loop for later use may be possible. After a literature search and reading it was seen that this might open up the possibility of using a device based on the time slot interchanger²³ (TSI), use in time division multiplexing for fast optical networks

17 CONCLUSIONS

We should continue the design of a “photon gun” time-bin entanglement switching system, continue learning COMSOL Multiphysics and develop the first “photon gun” model for a source in a characterization system.

OTHER TYPES OF INTERCONNECTS NEEDED FOR QUANTUM COMPUTING

18 SUMMARY

The literature in the area of quantum memory and quantum processor to memory I/O was searched and read in order to gain an understanding of future possible areas of development in this area. Plans for further collaboration as part of a new interdirectorate LRIR were made.

19 INTRODUCTION

The probabilistic nature of quantum computation requires some form of qubit storage as part of the measurement process²⁴. Although photons are excellent “qubit carriers” for fast and reliable long-range communication, storage of photons is still a laboratory process. Just like in classical optical interconnects, results must be stored in changes in material systems that can be addressed and read out using light. In quantum computation, specially prepared ions or atoms are used for qubit storage. These specially prepared atoms and ions are stationary objects in the current state of quantum computation and cannot be used as qubit carriers²⁵.

20 METHODS, ASSUMPTIONS, AND PROCEDURES

20.1 Memory to Processor I/O

Future work in this area could initially be guided by the most current approach to memory I/O, that of Monroe’s group at the University of Maryland²⁶. Duplicating this experiment in other quantum computing implementations would be important since this will be an important tool in any large scale quantum computation (distributed or not) where it is difficult to bring remotely separated qubits into physical contact to entangle them. From this starting point, we could develop a fiber-optic single-photon quantum interconnection technology, to allow qubits to be transferred efficiently between nodes of a DQC and/or to form a quantum network. Transport along a low-loss fiber is easy. The hard part is to transfer the quantum state from the qubit to the photon and back.

20.2 Quantum Repeaters

Especially of interest for quantum networking is the use of quantum repeaters²⁷ to overcome limitations in communication range due to decoherence. These repeaters are basically small quantum computers whose job it is to perform measurement, purification and relaying forward the correct purified quantum state. Quantum memory is required.

Quantum repeaters will probably be the first use of a complete quantum computer and should always be kept in mind as the working system goal of our work.

20.3 Optical Interconnects for the Integrated Optics Quantum CoProcessor (IOQCP) Chip

As mentioned, we have an interdirectorate AFOSR LRIR with Dr. Atilla Szep of the Sensors Directorate which includes strong interaction with Dirk Englund of Columbia University and MIT, who is an AFOSR YIP winner. Using the results of this program as a guide, we have discussed making a low loss optical interconnect between an optical entangled photon pair generator and the Integrated Optics Quantum CoProcessor (IOQCP) chip as well as an I/O interconnect from the chip into a quantum memory system.

The major new problem to be solved in interconnects for quantum computing is that entangled entities have to be transferred between different components that are often made using disparate technologies. Many recognize optical interconnects using entangled photons as the best method of doing this because of the demonstrated ability of optical systems to perform communication with low loss; however, little work in this area has been performed. We propose to test this hypothesis by using optical interconnects in a small system.

The IOQCP chip to be used is fabricated in LiNbO₃ which has a large index mismatch with optical fiber. In addition, the mode of the light in the fiber will not match the mode of the light in the chip. The scarcity of entangled photon pairs in comparison to the large photon flux normally used in optical interconnects means that low loss is especially critical in order to deliver enough entangled pairs into the chip for the faster computing that is enabled by the increased switching speed on the chip.

We ordered a probe station for use with solid state quantum computing components. The quantum computing team ordered a vibration isolation table to use with the probe station. The setup is installed and ready for use in the new interdirectorate LRIR.

21 RESULTS AND DISCUSSION

Beginning with the work on the IOQCP chip, we have a better understanding of the process that will enable us to help our quantum computing and quantum communications teams in the area of interconnects between source and processor and processor and memory.

22 CONCLUSIONS

Working closely with researchers investigating integrated single photon sources, we should determine the output parameters and design interconnects to maximize entangled pair transport to the processor chip.

Then, using our HOMI based test circuit, we should develop an interconnect that delivers the maximum number of entangled photons into the chip. This may include modified teleportation circuits as “handshaking” to ensure proper entangled pairs are being interconnected.

Later, working closely with researchers investigating quantum memory, determine input and output parameters and design I/O circuits to maximize transfer of quantum information to and from processors. This may include memory addressing and routing.

23 PROGRAM SUMMARY

We began building a Hong-Ou-Mandel interferometer based entanglement verification system. This will allow us to detect changes in entanglement due to imperfections in interconnect media and components. Members of our quantum computing team were very helpful and this gave our team an opportunity to learn the experimental techniques used in quantum optics.

We began to develop hyper-entanglement methods to allow for entanglement swapping and sacrificial pairs for destructive testing of entanglement. Hyper-entanglement is the ability to encode information in the multiple degrees of freedom of a qubit. These degrees of freedom can include polarization, spatial, OAM, momentum and spectral.

Some development of a technique for “photons on demand” was done for the case of sources for entanglement characterization systems.

The literature in the area of quantum memory and quantum processor to memory I/O was searched and read in order to gain an understanding of future possible areas of development in this area. Plans for further collaboration as part of a new interdirectorate LRIR were made.

24 PROGRAM CONCLUSIONS

Preliminary work has been done at AFRL in Rome to develop a test system to measure the ability of optical interconnect fibers, waveguide and components to transfer and/or switch entangled photons. There are no commercially available test systems capable of performing this important task. This system will be used to test the components used in both the source to chip and chip to memory subsystems.

The impact of this work in the short term will be in the area of interconnects for quantum repeaters and quantum memory. In the long term, this work will lead to an enabling technology for interconnecting disparate QC technologies like superconducting based approaches using optics. At this point in time there is no single technology that is seen as being useful for both computing and memory.

25 REFERENCES

1. Petar Pepeljugoski, et al., "Data Center and High Performance Computing Interconnects for 100 Gb/s and Beyond", Optical Fiber Communication and the National Fiber Optic Engineers Conference, pp. 1-3, 2007; Drew Alduino, et al., "Integration Challenges for Optical Interconnects", Photonics Packaging, Integration, and Interconnects VIII, Alexei L. Glebov, Ray T. Chen., eds., Proc. of SPIE Vol. 6899, 689910, (2008).
2. DiVincenzo, D. P. (2000). "The Physical Implementation of Quantum Computation." arXiv quant-ph/0002077v3.
3. Grover, L. K. (1997). "Quantum teleportation." arXiv quant-ph/9704012.
4. Cleve, R. and H. Buhrman (1997). "Substituting quantum entanglement for communication." arXiv quant-ph/9704026v2.
5. Lomonaco, S. J. and L. H. Kauffman (2006). Search for New Quantum Algorithms, Air Force Research Laboratory, Rome Research Site, AFRL-IF-RS-TR-2006-180.
6. Yimsiriwattana, A. and S. J. Lomonaco (2004). "Generalized GHZ States." arXiv quant-ph/0402148v3.
7. Eisert, J., J. Jacobs, et al. (2000). "Optimal local implementation of non-local quantum gates." Phys. Rev. A, 62(052317-1).
8. DiVincenzo, D. P. (1995). "Quantum Computation." Science 270: 255-261.
9. Van Meter, R. and M. Oskin (2006). "Architectural Implications of Quantum Computing Technologies." ACM Journal on Emerging Technologies in Computing Systems 2(1): 31-63.
10. Steane, A. M. (2003). "Overhead and noise threshold of fault-tolerant quantum error correction." arXiv quant-ph/0207119v4.
11. Van Meter, R. and M. Oskin (2006). "Architectural Implications of Quantum Computing Technologies." ACM Journal on Emerging Technologies in Computing Systems 2(1): 31-63.
12. Spiller, T. P., K. Nemoto, et al. (2006). "Quantum computation by communication." New Journal of Physics 8(30): 1-25.
13. Chang, D. E., A. S. Sorenson, et al. (2007). "A single-photon transistor using nanoscale surface plasmons." Nature Physics 3: 807-812.
14. M. A. Nielsen, "Optical Quantum Computation Using Cluster States", Physical Review Letters, Vol. 93, No. 4, 23 July 2004.
15. Kok, P., W. J. Munro, et al. (2007). "Linear optical quantum computing with photonic qubits." Rev. Mod. Phys. 79(Jan-Mar. 2007): 135-174.
16. Lomonaco, S. J. and L. H. Kauffman (2006). Search for New Quantum Algorithms, Air Force Research Laboratory, Rome Research Site, AFRL-IF-RS-TR-2006-180.
17. Kok, Pieter and Lovett, Brendon W. Lovett, "Optical Quantum Information Processing", Cambridge University Press (2010), pp. 129-134.

-
18. Hanbury Brown, R. and R. Q. Twiss (1957). "Interferometry of the intensity fluctuations in light. I. Basic theory: the correlation between photons in coherent beams of radiation." *Proc of the Royal Society of London A* 242(1230): 300-324; Hanbury Brown, R. and R. Q. Twiss (1958). "Interferometry of the intensity fluctuations in light. II. An experimental test of the theory for partially coherent light." *Proc of the Royal Society of London A* 243(1234): 291–319.
 19. Hong, C. K., Z. Y. Ou, et al. (1987). "Measurement of subpicosecond time intervals between two photons by interference." *Phys. Rev. Lett.* 59(18): 2044-2046.
 20. Santori, C., D. Fattal, et al. (2002). "Indistinguishable photons from a single-photon device." *Nature* 419(6907): 594-597.
 21. Joobeur, A. and B. A. E. Saleh (1994). "Spatiotemporal coherence properties of entangled light beams generated by parametric down-conversion." *Physical Review A* 50(4): 3349-3361.
 22. Mower, J. and D. Englund (2011). "Efficient generation of single and entangled photons on a silicon photonic integrated chip." *Phys. Rev. A* 84: 052326.
 23. Hinton, H. Scott, "An Introduction to Photonic Switching Fabrics", Plenum (1993) pp. 20-22.
 24. Duan, L.-M., et al., Long-distance quantum communication with atomic ensembles and linear optics. *Nature*, 2001. 414: p. 413-418.
 25. Cirac, J.I., et al., Quantum State Transfer and Entanglement Distribution among Distant Nodes in a Quantum Network. *Phys. Rev. Letters*, 1997. 78(16): p. 3221-3224.
 26. Olmschenk, S., et al., Quantum Teleportation Between Distant Matter Qubits. *Science*, 2009. 323: p. 486-489.
 27. Childress, L., et al., Fault-Tolerant Quantum Communication Based on Solid-State Photon Emitters. *Phys. Rev. Letters*, 2006. 96(070504).

Final Report

Quantum Wavelength Hyperentanglement

Prepared by:

Prof. Henry Zmuda

University of Florida

Department of Electrical and Computer Engineering

PO Box 116200

Gainesville, Florida 32611-6200

Prepared for:

Dr. Joseph Osman

Air Force Research Laboratory

Under Contract FA8750-09-2-0157

Visiting Faculty Summer Research Program

April 2011

ABSTRACT

This research begins an investigation of wavelength-based (or frequency/energy-based) hyperentanglement. It is well known from telecommunication applications that wavelength multiplexing multiplies the channel capacity of a conventional system. Such spectral encoding can be incorporated to single photon use as well and as a consequence the frequencies within a photon pair can be entangled. When this is done they may be available for further multi-photon pair entanglement unless the configuration takes the wavelength entanglement into account. At present, Spontaneous Parametric Down-Conversion (SPDC) is the only photonic method with the mode quality needed for high quality quantum interference. Any hyperentanglement approach, such as 2-path, multiplies the qubit number for all photons in the system. Three additional binary degrees of freedom for example would multiply a polarization qubit by a factor of eight, meaning that a six entangled photon demonstration could be extended to 48, a number that may finally enable viable applications. As a consequence, this work, though still in its initial stages, address a problem that could lead to a potential breakthrough for both quantum computation and quantum communication applications.

1. INTRODUCTION

Application of entangled photons to various tasks in Quantum (Q)-Information process are essential to every interconnection format, independent of whether the Q-communication or Q-computational devices themselves are based on photonic qubit based structures or a variety of others that include trapped ions or neutral atoms. This is due to the photon's non-interaction with other photons and relative low interaction with the transmitting media. This leads to low self-interference and freedom from environmentally induced decoherence which plagues (limits) every other implementation of Q-I processing approach. This does not make the photon based approach a panacea, but simply implies that the obstacles to be overcome are characteristically different in nature.

For Q-I processing to become practical in the sense of a useful device technology, namely in offering either unique capability or exceptional performance that exceeds that of appropriate state-of-the-art (classical) technology, a minimum of 50 to 100 (controllable!) entangled qubits with access/control is required. Presently there is currently no technology that can effectively implement much more than a dozen entangled qubits, and further scaling has, to this point, become more difficult with increased number of qubits rather than hoped for easement.

Communication and quantum key distribution (QKD) do not share such entanglement/scaling issues, and indeed have already been demonstrated outside the laboratory and even with limited commercial viability. The key limitations there are not only the in-principle immunity to eavesdropping, but the inherent limitations on range and generation rate for single (or entangled) photons. The price paid for perfect security is the sacrifice of any signal amplification Quantum No Cloning Theorem, and the slow recovery time of single photon counters. With one Mega-Hertz data rates and 100 km distribution lengths as the immediately foreseeable limit, such low data rates over such short ranges could be justified only in limited applications, perhaps those of the utmost importance.

In this work we address a potential breakthrough that could pertain constructively to both a Q-computation and Q-communication application focus. There will not likely be any single solution to the many and varied technical challenges that must be overcome, rather it will be the synergistic results of several solutions.

2. Wavelength Hyperentanglement

The term *hyperentanglement* refers specifically to the photon degrees of freedom, all of which can, in principle, be entangled. In most well-known applications of Quantum Entanglement (QE) such as photon teleportation, entanglement swapping, or quantum dense coding, etc. [1-3], polarization is the only photon property that is actually entangled, and all other must be carefully disentangled. Paul Kwiat and others were instrumental in explicitly co-entangling other properties such as momentum (path) [4]. Others such as Barnett and Zeilinger have included Orbital Angular Momentum (OAM) [5], which has the attractive feature of an infinite basis. The importance of any such hyperentanglement is that it multiplies the number of qubits that any **single** photon can embody. The deeper underlying problem is the fact that the generation

efficiency for *spontaneously generated* entangled photons decreases exponentially with the number. At present, Spontaneous Parametric Down-Conversion (SPDC) is the only photonic method with the mode quality needed for high quality quantum interference. Any hyperentanglement approach, such as 2-path, multiplies the qubit number for all photons in the system. Three additional binary degrees of freedom for example would multiply a polarization qubit by factor of eight, meaning that a six entangled photon demonstration, already done [6] could be extended to 48, a number that may finally enable viable applications.

We have initiated the investigation of wavelength (frequency) hyperentanglement based on one of the photon/s degrees of freedom, (equivalently denoted by energy). This investigation will be done in several thrusts. First it is well known that wavelength multiplexing multiplies the channel capacity of a conventional system. Such spectral encoding can be incorporated to single photon use as well. Second, the frequencies within a photon pair can be entangled [7]. When this is done they may or may not be available for further multi-photon pair entanglement unless the configuration takes the wavelength entanglement into account. Since these facts are known, the question arises as to why such an approach has not already been used or (effectively) pursued in this regard. The primary reason relates to quantum indistinguishability. In a typical polarization entanglement approach, the energy (or wavelength) spectrum is identical for the two pair photons so that no in-principle information can degrade the polarization interference. If we now wish to hyper-entangle the spectral property by making the photons two distinct “colors”, they then could provide such distinguishing information which must be taken into account.

Two illustrations can clarify the issues. There is a common misperception that a single photon has a single “color” (wavelength). This is not the case for the types of photons in which we are most interested, namely those in the form of a single photon wave packet, quite analogous to a classical light pulse with a time-bandwidth product. A typical example found in Spontaneous Parametric Down Conversion (SPDC) would be a wave packet with a temporal width of 100 femtoseconds and a spectral width of 10 nanometers centered at 800 nanometers. Although the detection may be localized to a single wavelength, the photon spectrum has a probability distribution over the entire spectral width.

The other distinct feature of spectra is its basis [8]. Polarization is a two-element basis, say Vertical (V) and Horizontal (H), and all polarizations can be formed by a linear combination of H and V. This includes Left and Right-Hand Circular Polarization as well. A polarizer aligned at 45 degrees to the two basis vectors transmits a portion of both, something that is not clearly the case with wavelength [9]. With a red centered and a blue centered photon, a spectral filter at an intermediate wavelength would transmit neither! Thus there are no rotators or wavelength converters readily available as is the case for a polarization basis. This places constraints on wavelength entanglement, but it will be seen that it does preclude very useful progress.

It is well known that teleportation of (the polarization state) of photons is no longer a novelty. Rather it is an essential element of most projected quantum repeater designs and also many error correction protocols in Linear Optics Quantum Computation (LOQC). It is not so well known that teleportation of the spectral state of entangled photons was proposed more than a dozen years ago by Molotkov [10] with experimental demonstrations more recently shown by Grice

and Kim [11] with forms of hyperentanglement. The drawback to both of the experiments was too low a data generation rate (~ 1 cpm) to be practical. This limited rate is due to the nonlinear up-conversion process of two single photons. These works used bulk crystals to achieve up-conversion, where interaction lengths are inherently limited. We will address this problem by the use of Periodically Poled (PPL) nonlinear waveguides to replace the crystals. It is straightforward via simulation to show that in principle a sufficiently long, lossless waveguide can raise the conversion probability from $\sim 10^{-9}$ to unity! The PPL-KTP waveguides identified as a means to address this limitation are now commercially available. Though they are limited in terms of length and losses, length, the interaction length offered can be more than orders of magnitude greater than that possible in bulk crystals. This would make the overall generation rate comparable to existing polarization teleportation.

We initiated alignment methods for coupling entangled photons into Single Mode Fiber (SMF). The PPL-KTP waveguides were not available until well after the period of the initial investigation (conducted as part of Air Force Summer Faculty Research Program) but the methodology is quite similar. The measurements that were made also established the extreme wavelength sensitivity of the SMF coupled lenses. The primary task was to establish if these wavelength-based methods could be used at all when high coupling efficiency was required, since SMF coupled lenses offer a highly rugged, compact alternative to bulk aspheric lenses in free space. It was found that wavelength sensitivity of the catalog items was greater than that anticipated by the vendor, and in particular too large to permit coupling at the precise 810 nm wavelength of our single photons. Customized assemblies were therefore specified and ordered. These arrived at AFRL subsequent to the summer research.

The experiment pursued was a Hong-Ou-Mandel Interferometer (HOMI) in a Type II Beta Barium Borate (BBO) crystal source [12]. The Type II crystal was essential because it is non-collinear (i.e. it has two photon paths) so as to enable polarization-path entanglement. Mandel's original quantum interference experiments were all based on Type I crystals with identical polarization which does not permit spatial path separation. The objective was to use multimode fiber (to compare with prior work) and experimentally establish the interference visibility limits for each pump laser, Continuous Wave (CW) and pulsed-modelocked. It was found that to resolve the interference limit using a CW test laser, fine time delay tuning would be necessary (less than 1 mm of birefringent quartz). Other members of research team subsequently ordered a self-compensated pair of quartz prisms (a Babinet-Soliel birefringence compensator). Their translation yields a tunable time-path delay that resolves the problem. The prisms also arrived subsequent to the summer research period.

Perusal of current research in hyper-entanglement reveals that polarization, momentum (lateral path type and time-bin) are under active investigation, but spectral (wavelength) are not. The primary reason for this is the fundamental problem of manipulating the distinguishing information in the wavelength. To clarify this we visualize with the aid of Figure 1, where two (polarized) photons entering a lossless polarizing beamsplitter (PBS) at 45 degrees. Two photons will exit, but now in a new basis, and it will be impossible to distinguish the exit photons with input. However, if the input photons had different spectrally centered frequencies, that information could not be "erased" by the PBS, as it was for the polarization degree of freedom.

There is a way to make that wavelength information indistinguishable, but its technical difficulty and low efficiency have so far prevented its implementation. The method itself is conceptually straightforward though the execution is not. Consider the angular dispersion in the SPDC process itself, where a single pump photon gives birth to two photons. If energy is conserved in the process then the (detected) wavelengths of the photons are entangled and sum to the correct pump photon energy, yet neither possessed a determinate energy value prior to detection! The nonlinear generation process is reversible, so that if the two photons “retrace” their paths into the NL crystal, there would be an amplitude to up-convert into a single photon identical to a pump photon, but propagating in the reverse direction. The key feature is that this process completely erases all information with regard to the color of the two photons, because any combination that sums to the correct pump energy value would yield an identical result. This need not be done in reflection, and transmissive configurations are equally effective and simpler to implement for combining photons from several down conversion sources. This photon-photon interaction can be incorporated in certain hyper-entangled wavelength configurations.

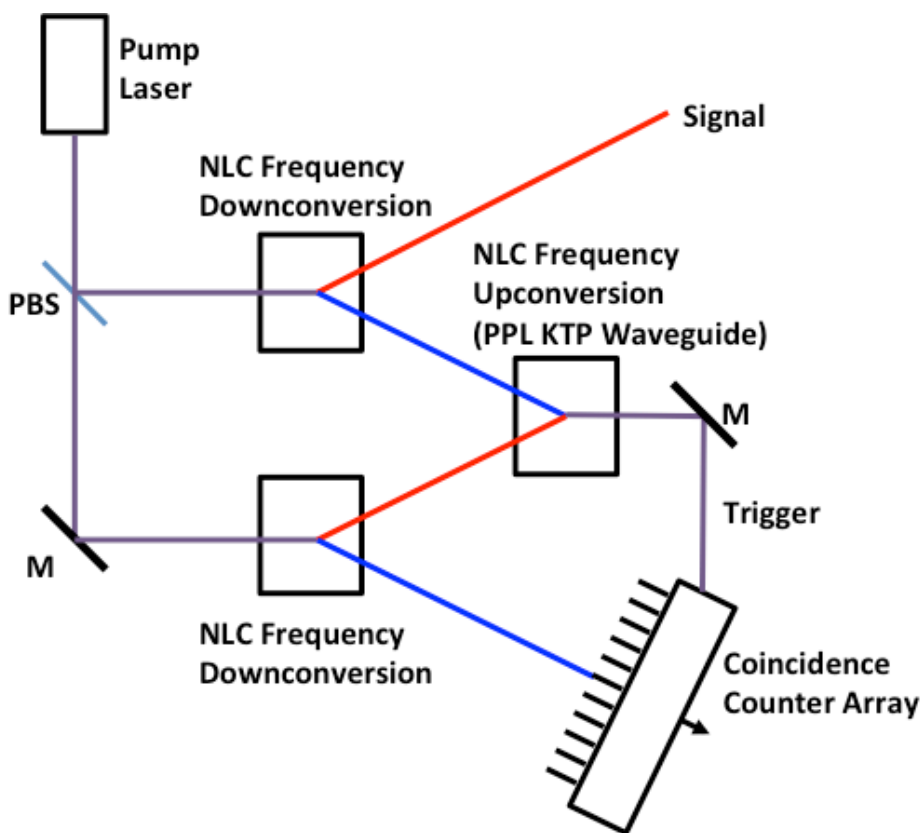

Figure 1: Conceptual arrangement for a wavelength-based hyperentangled system.

In classical information processing, Wavelength Division Multiplexing (WDM) is well established as a means to multiply a communication network or link capacity using the number of separate wavelengths implemented in the hardware. There are analogies to such Q-IP

versions, but there are also differences in the way the hardware functions. The parallel processing in the Q-IP comes from the ability to encode multiple information on each single photon, i.e., in each of its degrees of freedom. An attractive feature of wavelength entanglement is that it offers as many channels as the hardware can distinguish. This can be accomplished using well-known methods such as properly sequenced dichroic filtering or diffractive spatial separation. Each channel can be encoded with information independent of the others, and the final state realization is done with wavelength selective single photon detectors. Ideally this would be based on a detector array, similar to the CCD arrays used in the near IR. At present, single photon detectors are not yet available in array format, so the state reconstruction could be done with a multimode mode fiber array located at a spectrally dispersed focal plane, with each fiber coupled to a photon counter. The coincidence counts are triggered by the entangled up-converted partner as seen in Figure 1.

The ultimate limit on this approach is the efficiency of the up-conversion. The two main avenues toward optimizing this process have not been applied to in research up to this time. Those are to increase the non-linear coefficient (media dependent), or increase the effective interaction length with (nonlinear) SMF or properly phase-matched waveguide. The latter is within our control and availability and therefore is pursued first. It still remains unclear whether the efficiency achievable will be practical, but it is reasonably certain based on what has been done previously that such an approach will help allow a realistic assessment of the ultimate feasibility.

3. Conclusion

The Principle Investigator for this effort, working along with research members from the Air Force Research Laboratory Information Directorate have begun initial investigations of photon wavelength (frequency/energy) hyperentanglement as a means of increasing the number of entangled photon states. This work was performed as part of the Air Force Summer Faculty Research Program is new, and presents an initial study for future research that could lead to a potential breakthrough for both quantum computation and quantum communication applications.

Acknowledgement: Much gratitude is extended to Dr. Reinhard Erdmann, Dr. Joe Osman, Dr. Mike Hayduk, Dr. Paul Alsing, Mike Fanto, Tom McEwen from the Air Force Research Laboratory, and last but by no means least to Dr. Enrique ‘Kiko’ Galvez from Colgate University, all for their invaluable assistance. The author also wishes to thank the staff of the Summer Faculty Research Program for their support of this effort.

4. References:

1. D. Bouwmeester, J.W. Pan, K. Mattle, M. Eibl, H. Weinfurter and A. Zeilinger, "Experimental quantum teleportation", *Nature*, Vol. 390, 11 December 1997, pp. 575-579.
2. Jian-Wei Pan, Dik Bouwmeester, Harald Weinfurter, and Anton Zeilinger, "Experimental Entanglement Swapping: Entangling Photons That Never Interacted", *Phys. Rev. Letters*, Vol. 80, No. 18, 4 May 1998.
3. Xiaoying Li, Qing Pan, Jietai Jing, Jing Zhang, Changde Xie, and Kunchi Peng, "Quantum Dense Coding Exploiting a Bright Einstein-Podolsky-Rosen Beam", *Phys. Rev. Letters*, Vol. 88, No. 4, 28 Jan. 2002.
4. Paul G. Kwiat, Klaus Mattle, Harald Weinfurter, Anton Zeilinger, Alexander V. Sergienko and Yanhua Shih, "New High-Intensity Source of Highly Entangled Photon Pairs", *Physics Review Letters*, Vol. 75, No. 24, 11 December 1995.
5. Alois Mair, Alipasha Vaziri, Gregor Weihs & Anton Zeilinger, "Entanglement of the orbital angular momentum states of photons", *Nature* **412**, 313-316 (19 July 2001).
6. Travis S. Humble, Ryan S. Bennink, and Warren P. Grice, "Simultaneous Teleportation of the Spectral and Polarization States of a Photon" 2008 OSA/CLEO/QELS, Paper JTuA110.
7. Travis S. Humble¹, Ryan S. Bennink, and Warren P. Grice "Total teleportation of a single-photon state", *Proc. of SPIE* Vol. 7092, 70920V, (2008).
8. M. Reck and P. G. Kwiat (1995) <http://www.tongue-twister.net/mr/physics/entangled.htm>.
9. R.K. Erdmann, Quantum Interference Engineered by Dispersive Parameter Design, Doctoral Dissertation, University of Rochester, 2004.
10. S.N.Molotkov, "Quantum teleportation of a single-photon wave packet", *Phys.Lett. A*245 (1998) 339-344.
11. S.N. Molotkov, S.S. Nazin, "Photon frequency entanglement swapping". *Physics Letters A* 252 (1999) 1-4, 15 February 1999.
12. Giovanni Di Giuseppe, Mete Atature, Matthew D. Shaw, Alexander V. Sergienko, Bahaa E. A. Saleh, Malvin C. Teich, Aaron J. Miller, Sae Woo Nam, and John Martinis, "Direct observation of photon pairs at a single output port of a beam-splitter interferometer", *Physical Review A* 68, 063817, 2003.