

Transition of laminar pre-mixed flames to turbulence - induced by sub-breakdown applied voltage



Biswa N. Ganguly
*Aerospace Systems Directorate, Air
Force Research Laboratory
WPAFB OH USA*
and
Jacob Schmidt
Spectral Energies, Dayton OH

Report Documentation Page

Form Approved
OMB No. 0704-0188

Public reporting burden for the collection of information is estimated to average 1 hour per response, including the time for reviewing instructions, searching existing data sources, gathering and maintaining the data needed, and completing and reviewing the collection of information. Send comments regarding this burden estimate or any other aspect of this collection of information, including suggestions for reducing this burden, to Washington Headquarters Services, Directorate for Information Operations and Reports, 1215 Jefferson Davis Highway, Suite 1204, Arlington VA 22202-4302. Respondents should be aware that notwithstanding any other provision of law, no person shall be subject to a penalty for failing to comply with a collection of information if it does not display a currently valid OMB control number.

1. REPORT DATE NOV 2012		2. REPORT TYPE		3. DATES COVERED 00-00-2012 to 00-00-2012	
4. TITLE AND SUBTITLE Transition of laminar pre-mixed flames to turbulence - induced by sub-breakdown applied voltage				5a. CONTRACT NUMBER	
				5b. GRANT NUMBER	
				5c. PROGRAM ELEMENT NUMBER	
6. AUTHOR(S)				5d. PROJECT NUMBER	
				5e. TASK NUMBER	
				5f. WORK UNIT NUMBER	
7. PERFORMING ORGANIZATION NAME(S) AND ADDRESS(ES) Air Force Research Laboratory, Aerospace Systems Directorate, Wright Patterson AFB, OH, 45433				8. PERFORMING ORGANIZATION REPORT NUMBER	
9. SPONSORING/MONITORING AGENCY NAME(S) AND ADDRESS(ES)				10. SPONSOR/MONITOR'S ACRONYM(S)	
				11. SPONSOR/MONITOR'S REPORT NUMBER(S)	
12. DISTRIBUTION/AVAILABILITY STATEMENT Approved for public release; distribution unlimited					
13. SUPPLEMENTARY NOTES presented at the 2012 AFOSR MURI Third Year Review Meeting, 6-7 Nov, Princeton, NJ.					
14. ABSTRACT					
15. SUBJECT TERMS					
16. SECURITY CLASSIFICATION OF:			17. LIMITATION OF ABSTRACT	18. NUMBER OF PAGES	19a. NAME OF RESPONSIBLE PERSON
a. REPORT	b. ABSTRACT	c. THIS PAGE			
unclassified	unclassified	unclassified	Same as Report (SAR)	22	



Ionic Wind Effects - Background



- Potential role of **sub-breakdown electric fields** to augment/modify combustion kinetics and flame fluidics.
 - Lead to overall increase in stability, combustion efficiencies
 - Many experimental results reported over past sixty years.
- Direct experimental evidence or robust modeling of exact mechanism by which **sub-breakdown** applied voltage modifies flame fluidics and kinetics are currently not unequivocally known.
 - Lift-off and blow-off limits of flames extended by AC\DC field induced ion wind by Kim et al.¹
 - Adiabatic burning velocity increase by DC imposed electric current through thermal power release and/or direct chemical reaction rate proposed by van den Boom et al.²

¹Kim M, Ryu S Won S, Chung S(2010) Combustion and Flame 157(1):17-24

²van den Boom J, Konnov A, Verhasselt A, Kornilov A, de Goey L, Nijmeijer H (2009) Proceedings of the Combustion Institute 32:1237-1244



Ionic Wind Body-Force

- The ion and electron volumetric forces on a neutral molecule can be represented by the two equations below:

$$f_i = n_i m_i v_{im} u_i$$

$$f_e = n_e m_e v_{em} u_e$$

- Using the drift-diffusion equations and charged particle mobility expressions¹, it is possible to rewrite these equations as the following:

$$f = e(n_i - n_e)E - kT_i \nabla n_i - kT_e \nabla n_e$$

Assuming:

Average number density of positive ions for a near stoichiometric C₃H₈/air flame at atmospheric pressure $\approx 3 \times 10^{16} \text{ m}^{-3}$

Maximum possible gradient exists over 0.2mm reaction zone thickness.

Gradient terms provide a body force of about 3.5N/m³

¹ Boeuf, J. and Pitchford, L., *J. Appl. Phys.*, Vol. 97, 2005, pp. 103307:1-10.



Wire Loop Cathode with Burner Floating

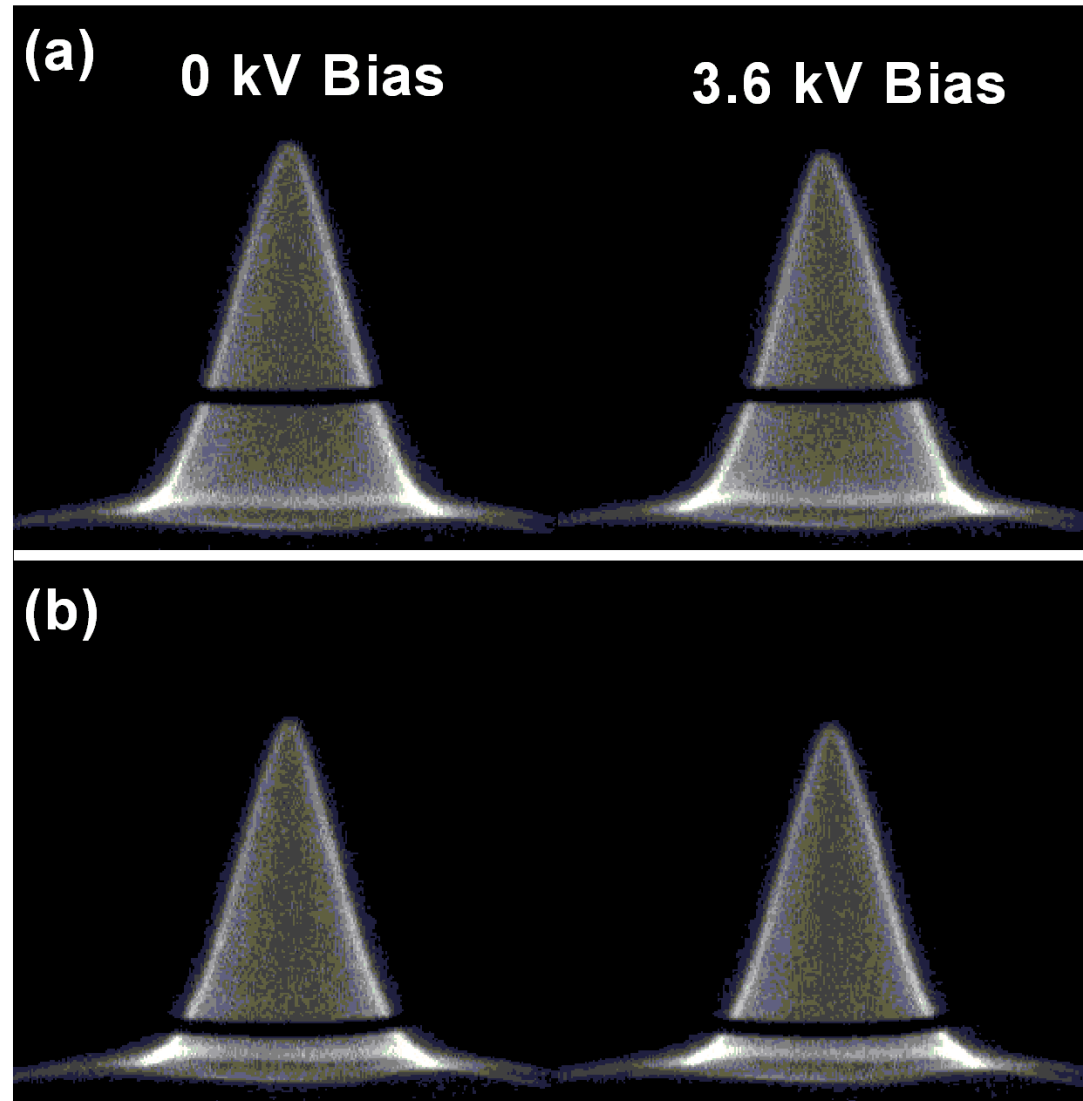

- Flame with wire loop as cathode. In figure (a) the loop was placed 5 mm above the **floating burner**, whereas in figure (b) the loop was placed 2mm above the **floating burner**.
- As the voltage is applied up to a positive 3.6 kV value, there is no observable change in the flame height or stability.
- Images are taken with a 308 nm band-pass filter in place to allow the imaging of the OH* chemiluminescence, which can be used as a marker for the flame front.



Burner Head Cathode



0 kV Bias

3.6 kV Bias

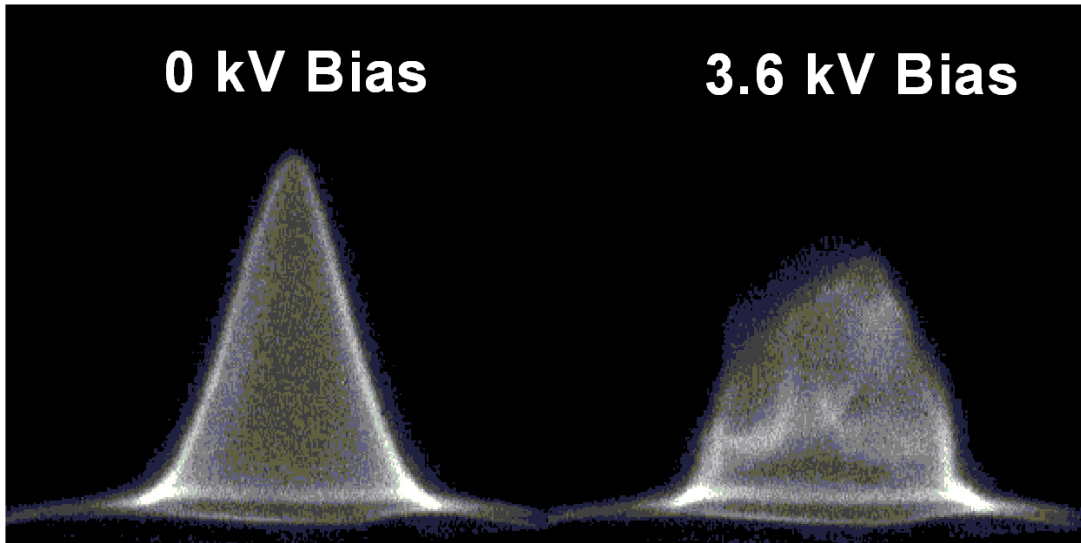

10 ms exposures

Difference in flame heights with and without an applied voltage suggests an effective flame speed increase of approximately 35%.

- Flame with the burner head grounded. In this case the wire loop has been completely removed, and the sheath is formed at the burner head (**preheat zone**).
- As the voltage is applied, there is a significant change in the flame height and stability.
- Images were taken with a 308 nm band-pass filter. The blurring seen when the voltage is applied is due to the rapid movement of the flame front, and the long time exposure of the camera.



Sheath Formation

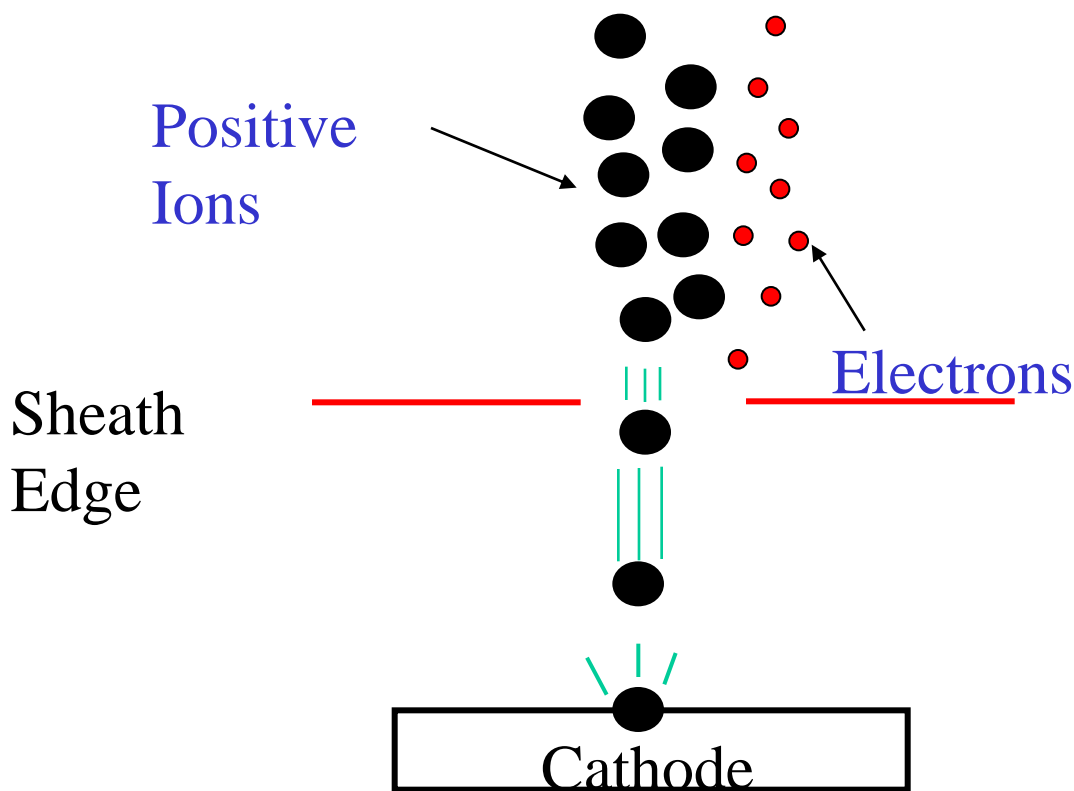

- The applied positive bias sets up a cathode sheath at the flame-metal surface boundary.
- The electrons are repelled from the cathode and the positive flame ions are attracted to it. This creates an area in the flame with a net positive charge.
- As the positive ions reach the cathode (burner head or wire loop) some of them will collide with the neutrals imparting momentum transfer.

The positive ions are accelerated as they approach the sheath edge, causing them to reach the Bohm velocity.



Ionic Wind Effects at the Sheath



- The effects of both the density gradients and the cathode sheath would be present near the ring electrodes, where we find no measurable effects of ionic wind.
- Near the burner head, the ionic wind-induced body-force on the flame should be dominated from the cathode sheath. The average volumetric force is given by,

$$f = Ee n_i \approx 500 \text{ Newton m}^{-3}$$

for $E=1.5 \times 10^5 \text{ v/m}$, and $n_i \approx 3 \times 10^{16} \text{ m}^{-3}$

- Multiplying the volumetric force by the sheath thickness (taken to be 5 electron Debye length, λ_D) gives an expression for the average pressure change across the flame due to the ionic wind effects.

$$\Delta p = 5Ee n_i \lambda_D \approx 3 \times 10^{-3} \text{ Pascal}$$

Can such a small pressure change impact flame structure?



Flame Structure Modification By Applied Voltage

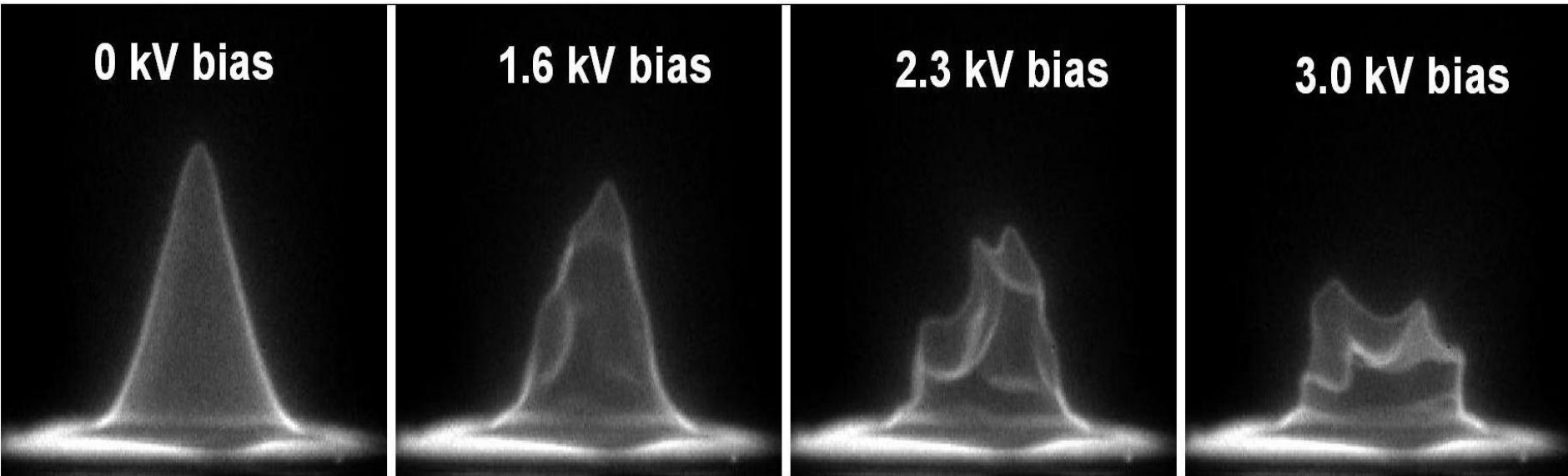

Broadband images of a propane/air flame at atmospheric pressure with an equivalence ratio of 1.0. Starting from left to right the voltage is increased (as indicated above the flame) to show flame structure changes with an applied electric field vector opposing flow velocity.



Temporal Scan of 10 Hz PIV and OH Chemiluminescence

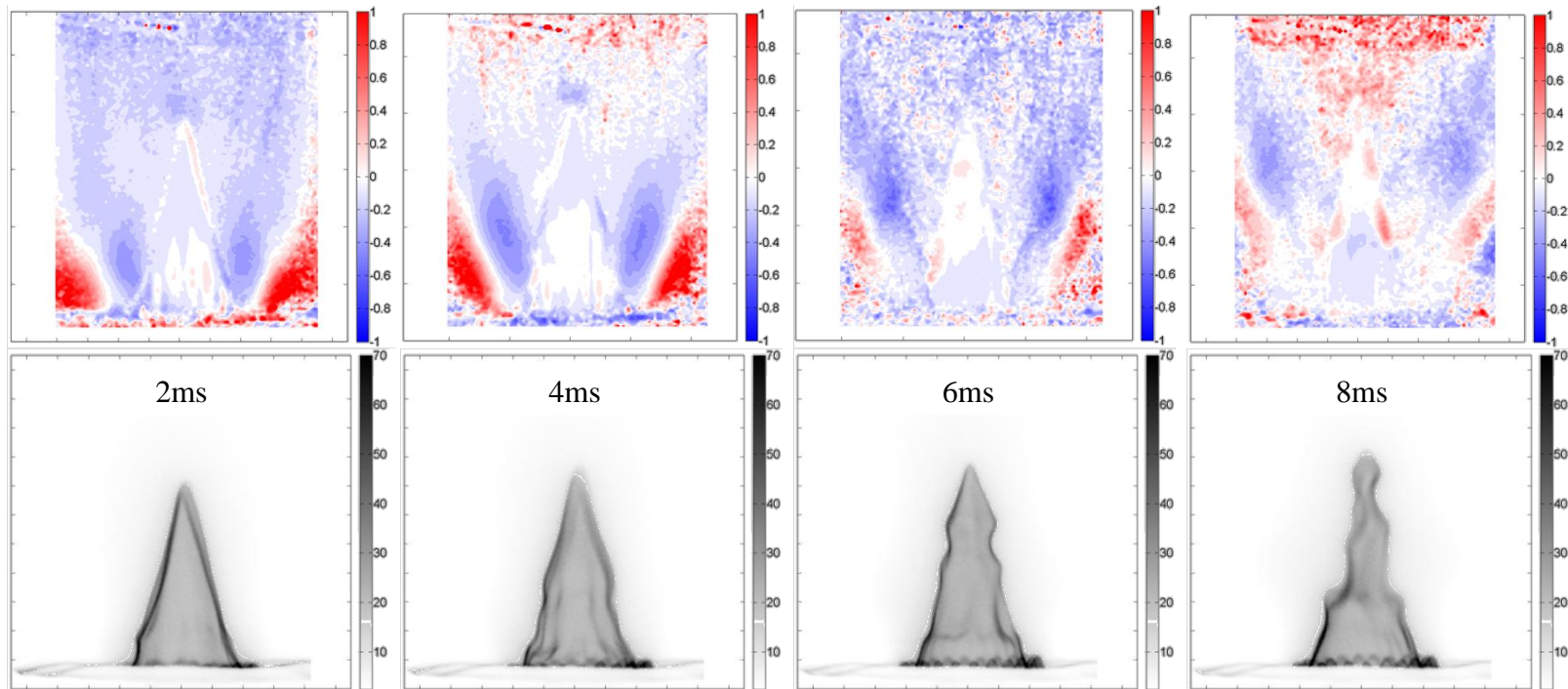

- +2kV 30 ms pulsed @ 10Hz applied downwards over 40mm gap
- Maximum velocity decrease (~40%) occurs at end of voltage pulse
- 'Track' perturbation origination to very near-burner head region at voltage onset ($t = 0$ ms)
- Time-stitched PIV data assumes pulse to pulse reproducibility



2 KHz Broadband Chemiluminescence

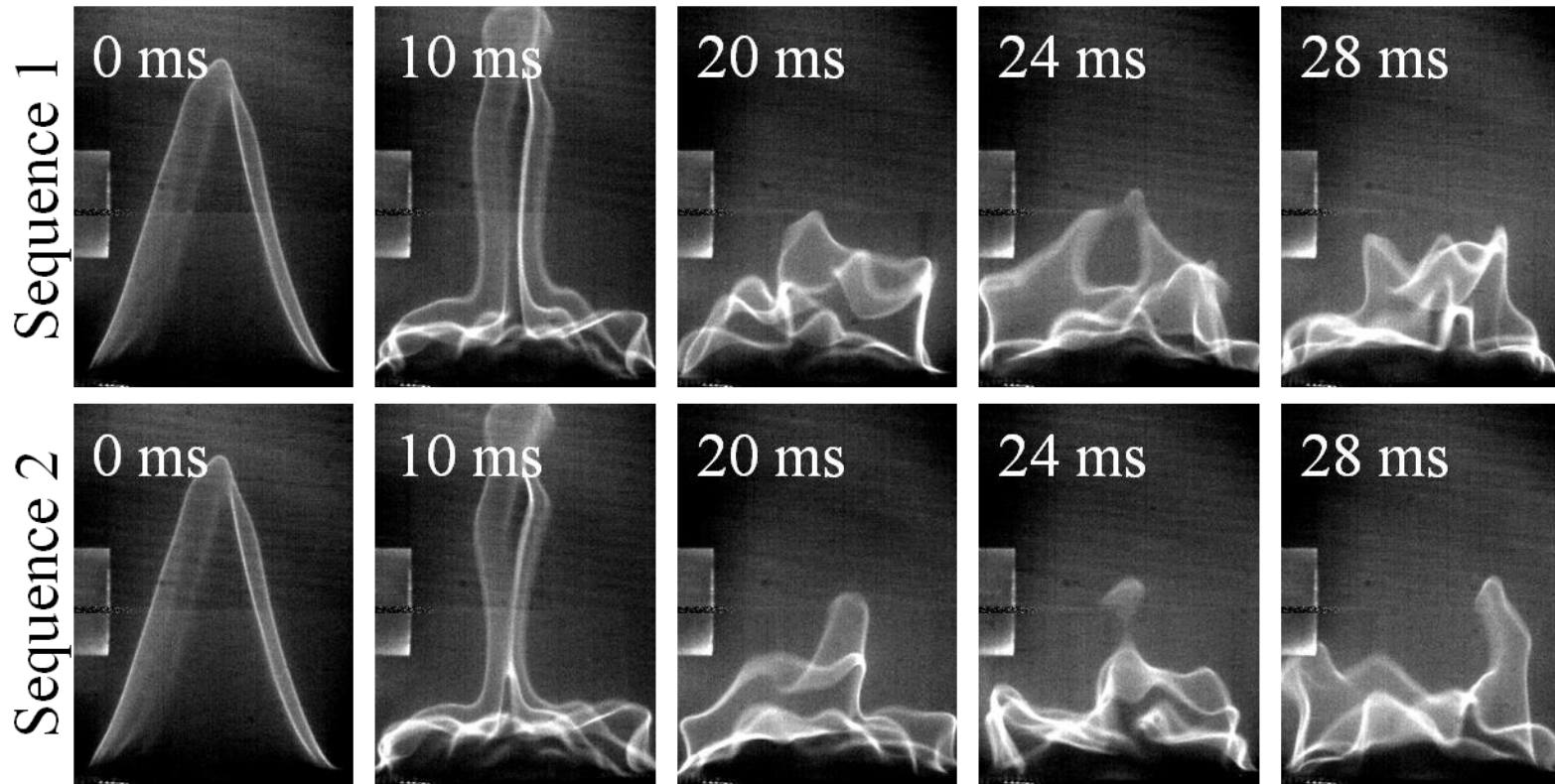

Flame structure modifications are reproducible up to 10 ms and shows stochastic behavior beyond 20 ms.



Heat Release Modulation via OH* and Broadband Emissions vs Current

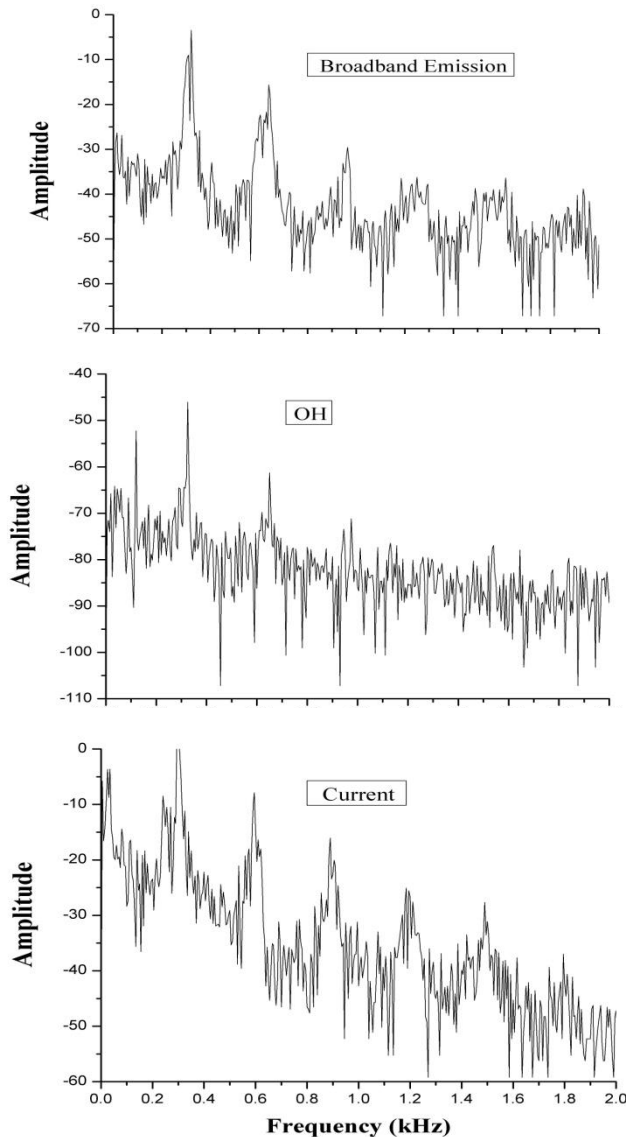

- The frequency spectrum of the OH* emissions from the flame are essentially identical to the that obtained from the bias circuit's *current waveform*.
- The OH* emissions have been shown to correctly directly with local heat release.
- These results suggest that conductivity probes might offer an alternative to optical diagnostic approaches for detection of the onset of pulsating, oscillatory or otherwise unstable combustion conditions.



Flame Turbulence Induced by Ionic Wind Effects



- Both high speed imaging and FFT data show the pre-mixed laminar flame is transitioning to turbulence.
- Time stitched PIV data captures only time averaged flame structure modifications.
- A high repetition rate PIV measurement can capture the true flame structure modification induced by chemi-ion drift current induced body force exerted to the flame.
- 6 KHz rep rate PIV measurement is performed to obtain *real time* fluid flow modification using dual cavity frequency doubled Nd:YAG laser.



Experimental Schematic

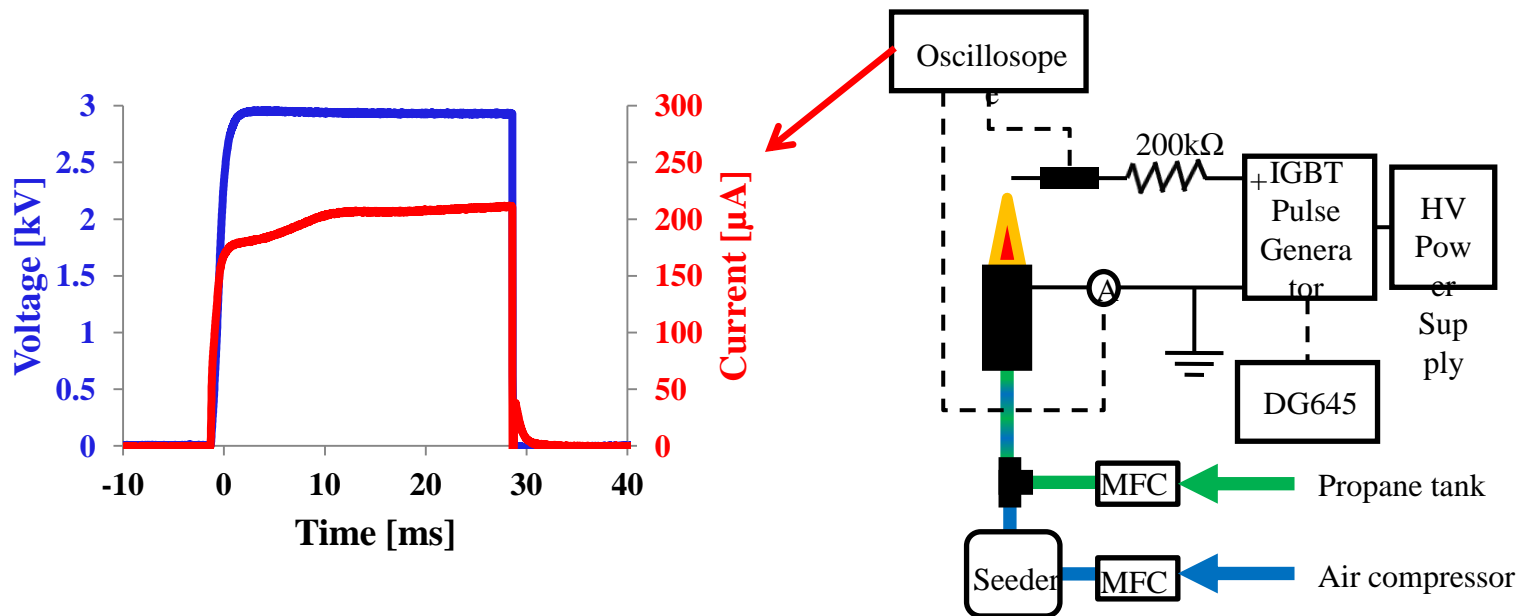

- 30 ms voltage pulse duration @ 10Hz
- 3 kV, 200 μ A, 0.2 Watt



High Rep Rate PIV Experimental Setup

Laser imaging

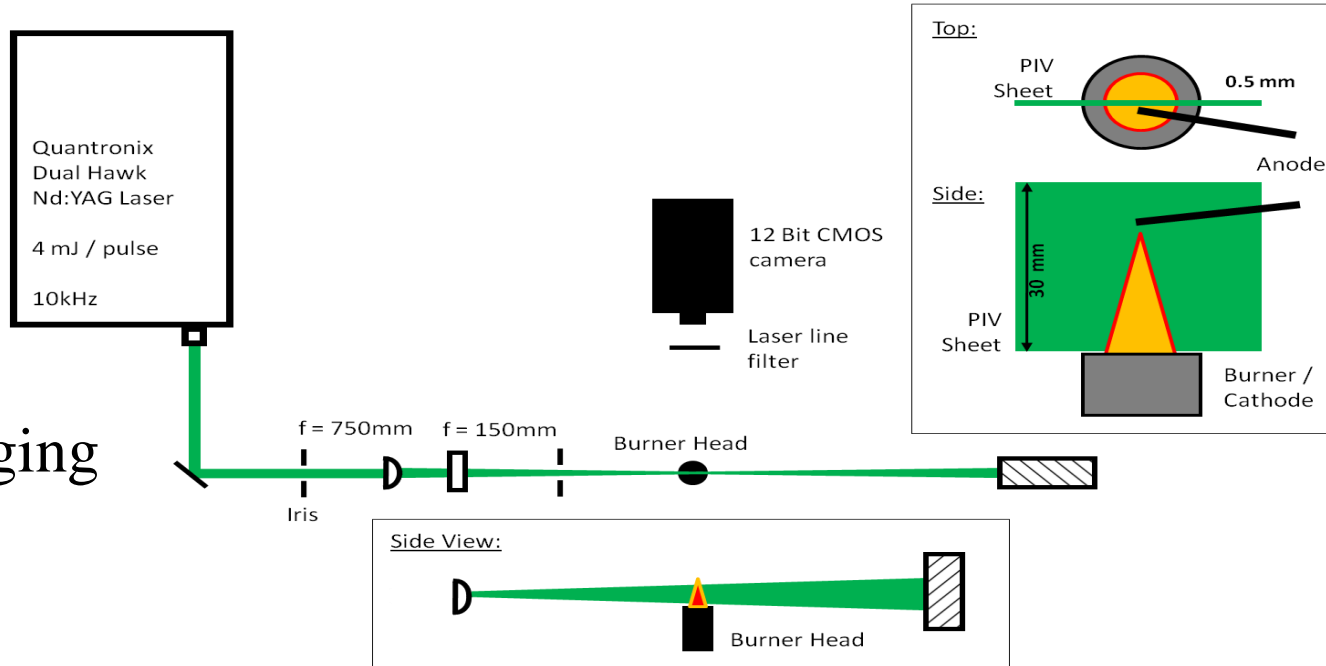

Burner layout

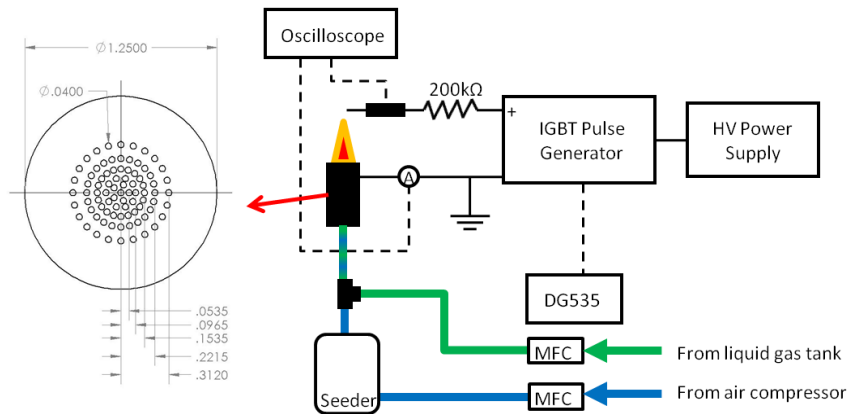



Typical PIV Data

- Photron SA5 (12Bit CMOS) camera imaging @ 6kHz with 768 x 768 resolution
 - 80 μ s exposure times with 0.032 mm/pixel spatial resolution
 - 25mm x 25mm region of interest imaged
- Collected and processed initially with DaVis 8.2 software from LaVision Inc.
 - Sequential cross-correlation scheme with double passes of 64x64 and 32x32 pixel regions rejecting areas of too high seed density or low contrast (48 x 48 vector field)
- Displaying sample data with delay shown relative to onset of 30 ms applied voltage pulse

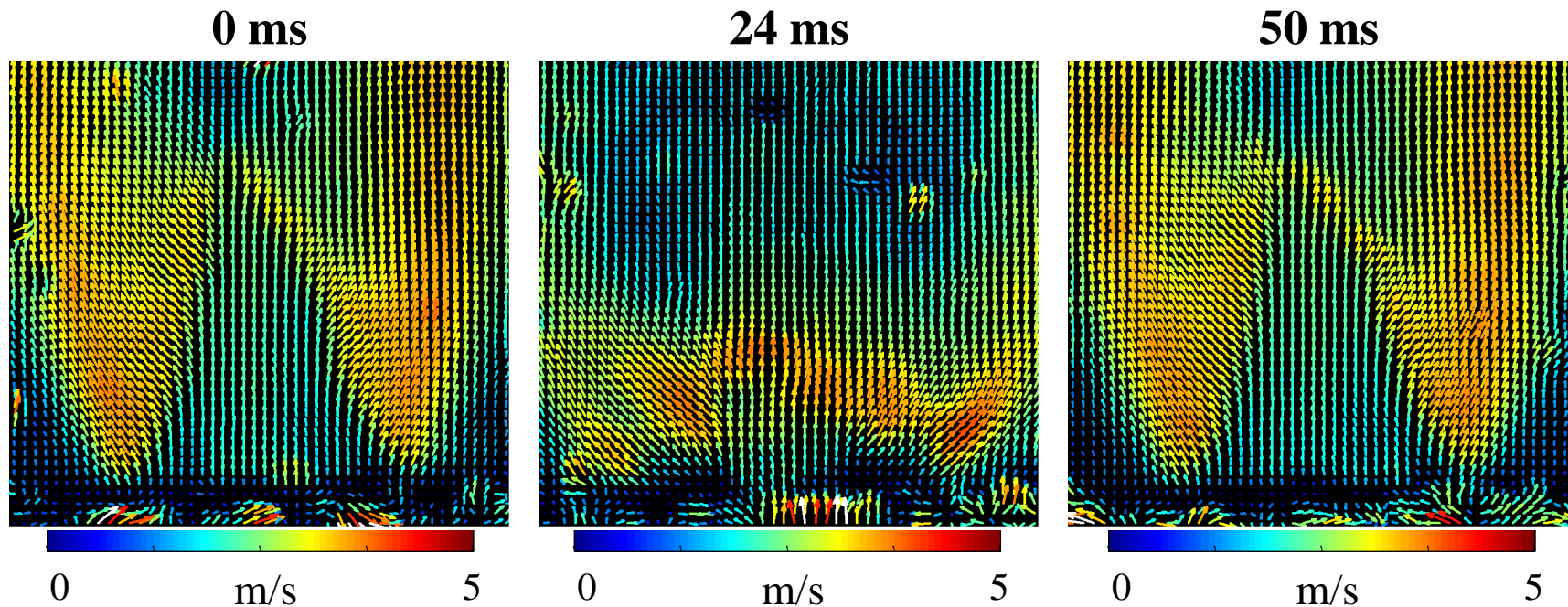



6 kHz PIV Data

The six different PIV velocity vector sets show different temporal positions of the same flame subjected to $\sim 3.0\text{kV}$ positive polarity applied voltage pulse of 30 milliseconds (ms) in duration, from an anode (just out of view) placed above the flame and 30 mm above the grounded burner body.

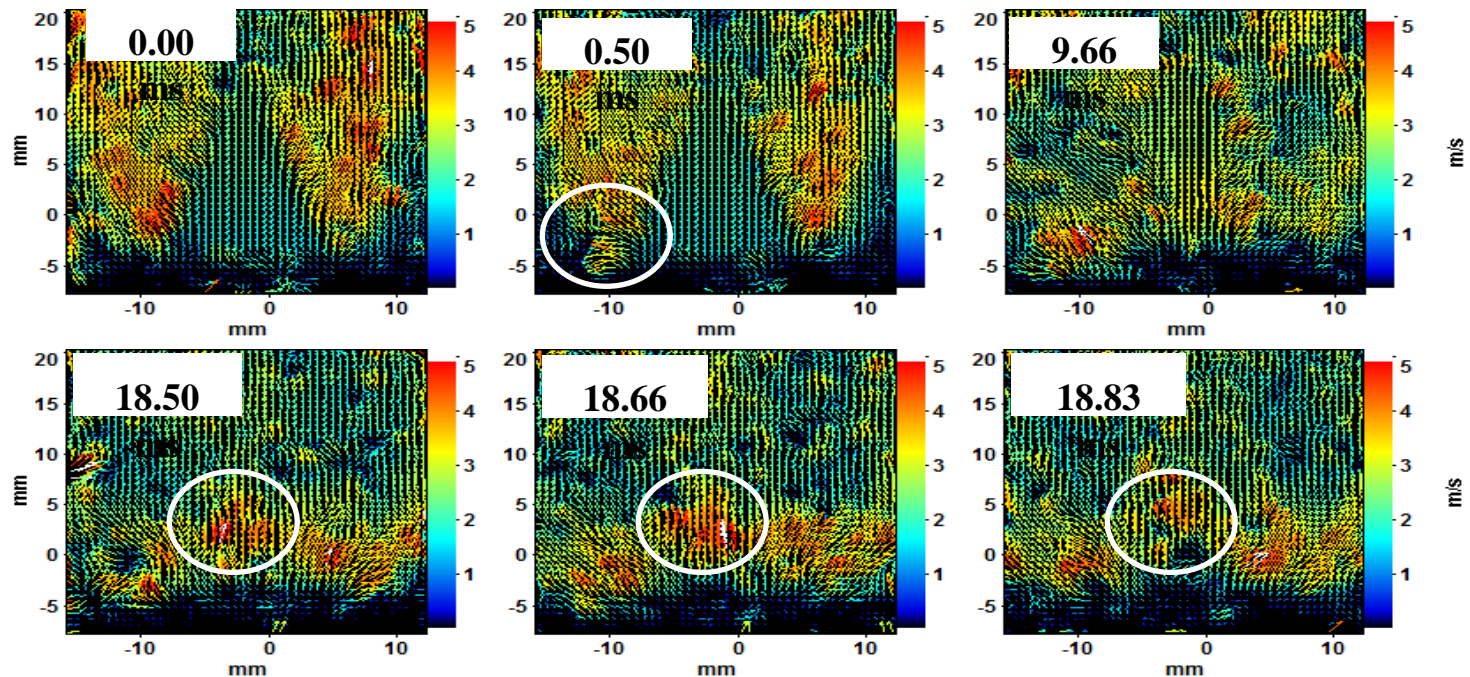

Four regions are highlighted which show the advantage of high rep rate PIV data showing real time evolution of flame fluidics.

Highlighted regions in 18.5 and 18.66 ms data show velocity change by $+ 0.75\text{ m/s}$; 18.66 and 18.83 ms data show velocity change by $- 0.6\text{ m/s}$.



Velocity Histograms at Three Locations

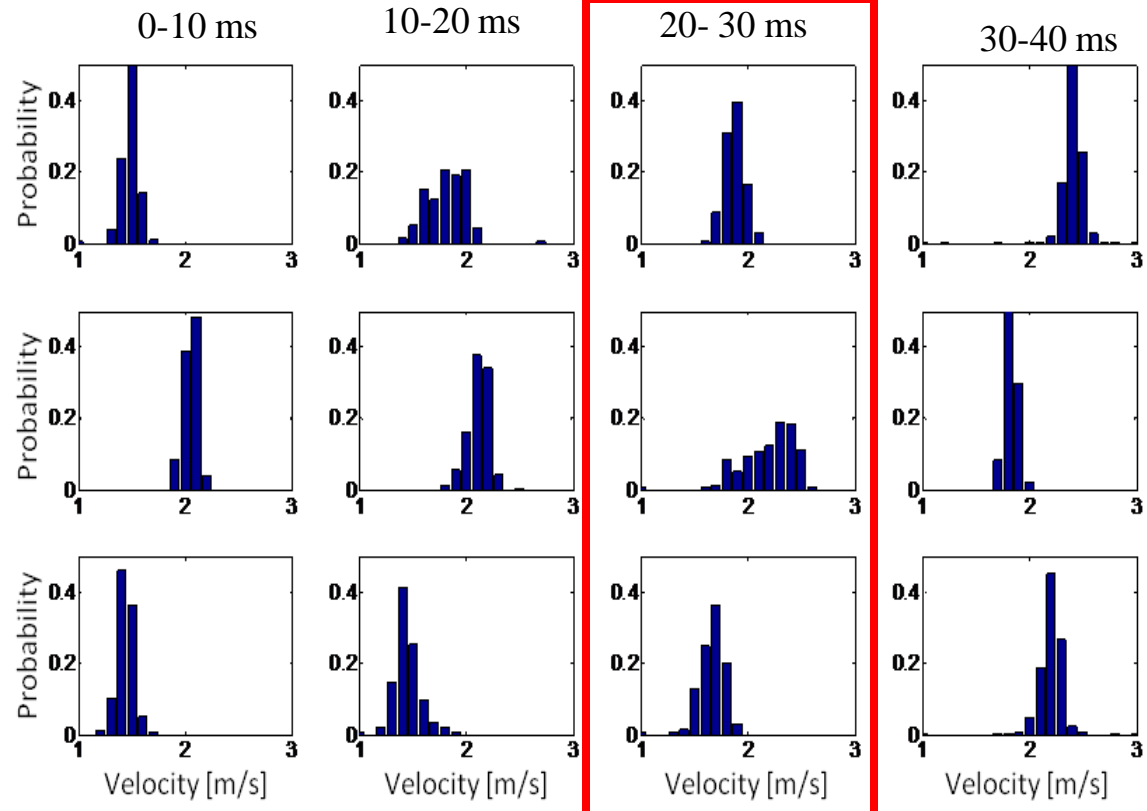
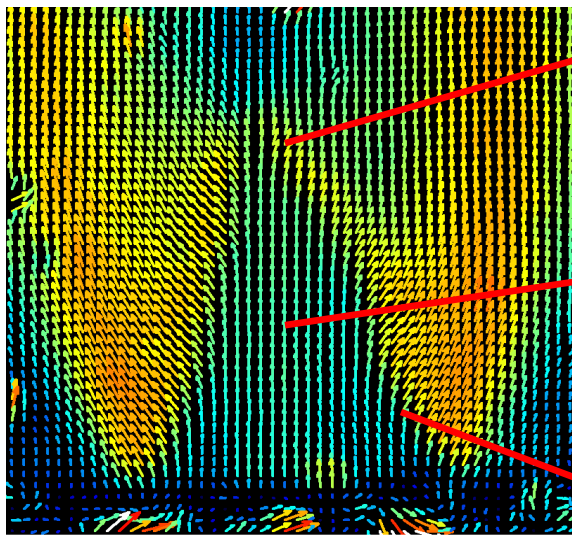
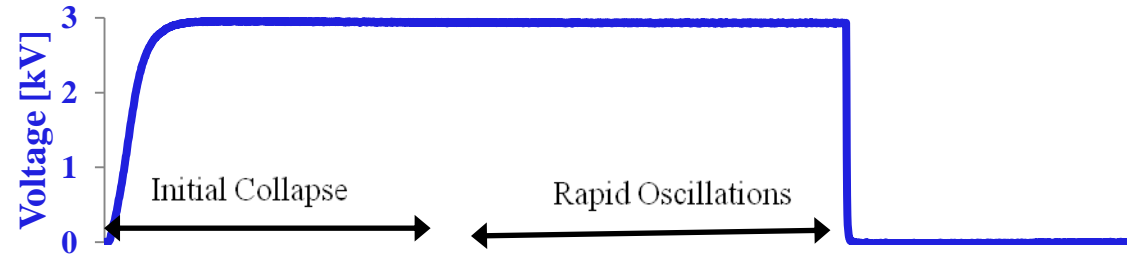



Plots of $\partial V_v / \partial y$ for Two Locations

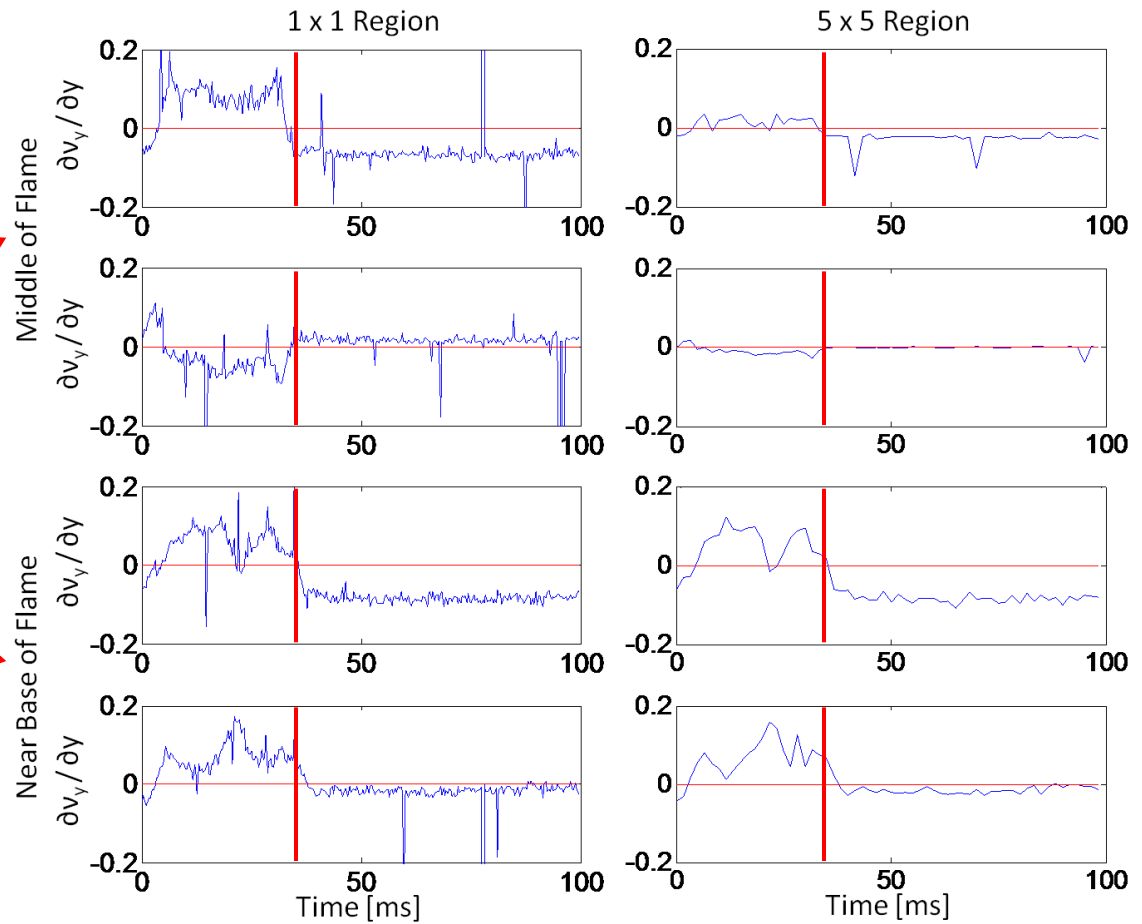
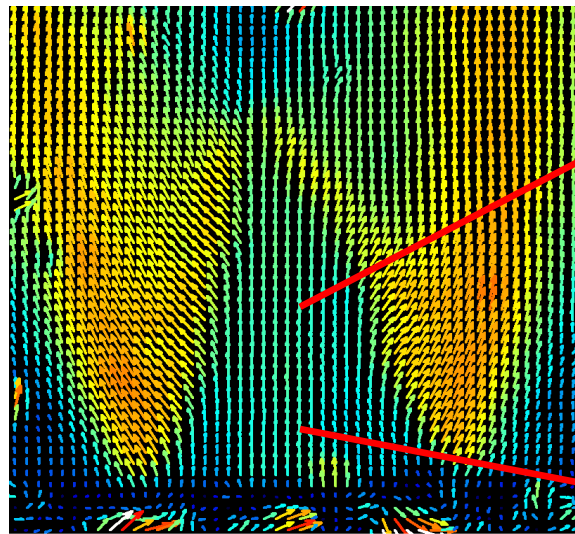



Conclusion From kHz PIV Data

- Investigated fluidic response of flame perturbations caused by ms-wide voltage pulses below self-sustained breakdown. Observed 0.25 W electrical input power have very significant effect on 1.4 kW flame structure.
- High electrical efficiency is due to no ionization energy cost with sub-breakdown electric field.
 - Relatively small amount of electrical power can cause an otherwise stable, laminar flame to highly unstable behavior/ transition to turbulence.
 - Higher $\partial V_y / \partial y$ in center of flame suggesting highly strained burning condition.
 - Velocity histogram shows the onset of induced turbulence beyond 15 ms, consistent with high speed imaging and FFT.
 - Observed benefits include lateral flame spreading and reduced flame height resulting in modified heating zones near burner surface with potential for positive implications such as improved flame holding.
- Response after voltage is shut off suggests that recovery mechanism is mostly fluidic in nature.
- High speed measurements are essential for quantifying turbulent phenomena.



Acknowledgements

- Wish to thank Stan Kostka for his help with the data taking.
- Thanks to Sukesh Roy and Jim Gord for use of their new PIV systems.
- Work was supported by Chiping Li, AFOSR.



6 kHz Repetition Rate PIV Data

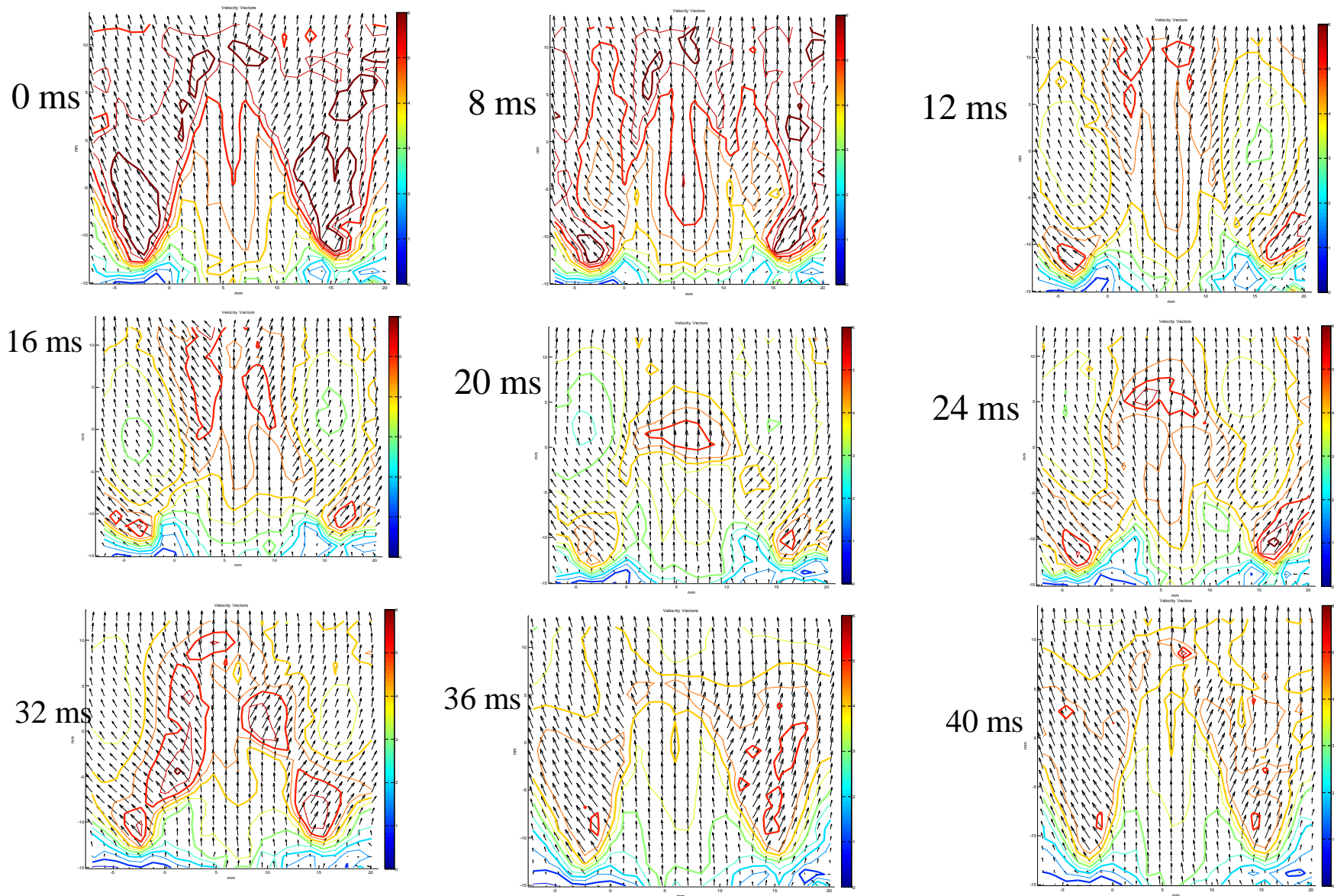



OH PLIF Data

- Five consecutive single shot OH PLIF data are taken at the same time delay.
- Shot to shot variation of OH PLIF after 8 ms delay is indicative of stochastic flame fluctuations. Agrees with the PIV data.

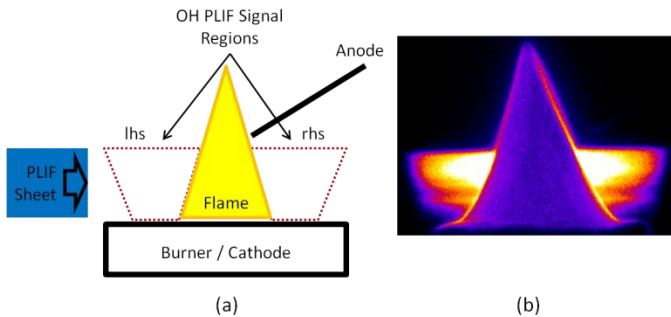

(a) OH PLIF Set-up
(b) Combined OH PLIF and flame chemiluminescence

