

REPORT DOCUMENTATION PAGE			Form Approved OMB NO. 0704-0188		
<p>The public reporting burden for this collection of information is estimated to average 1 hour per response, including the time for reviewing instructions, searching existing data sources, gathering and maintaining the data needed, and completing and reviewing the collection of information. Send comments regarding this burden estimate or any other aspect of this collection of information, including suggestions for reducing this burden, to Washington Headquarters Services, Directorate for Information Operations and Reports, 1215 Jefferson Davis Highway, Suite 1204, Arlington VA, 22202-4302. Respondents should be aware that notwithstanding any other provision of law, no person shall be subject to any penalty for failing to comply with a collection of information if it does not display a currently valid OMB control number.</p> <p>PLEASE DO NOT RETURN YOUR FORM TO THE ABOVE ADDRESS.</p>					
1. REPORT DATE (DD-MM-YYYY) 06-08-2012		2. REPORT TYPE Conference Proceeding		3. DATES COVERED (From - To) -	
4. TITLE AND SUBTITLE Analysis of the Efficiency Improvement of a Directly-Driven Antenna-Based AM Transmitter			5a. CONTRACT NUMBER		
			5b. GRANT NUMBER W911NF-04-D-0001		
			5c. PROGRAM ELEMENT NUMBER 611102		
6. AUTHORS Olusola O. Olaode, William T. Joines, W. Devereux Palmer			5d. PROJECT NUMBER		
			5e. TASK NUMBER		
			5f. WORK UNIT NUMBER		
7. PERFORMING ORGANIZATION NAMES AND ADDRESSES Duke University 130 Hudson Hall, Box 90271 Duke University Durham, NC 27705 -			8. PERFORMING ORGANIZATION REPORT NUMBER		
9. SPONSORING/MONITORING AGENCY NAME(S) AND ADDRESS(ES) U.S. Army Research Office P.O. Box 12211 Research Triangle Park, NC 27709-2211			10. SPONSOR/MONITOR'S ACRONYM(S) ARO		
			11. SPONSOR/MONITOR'S REPORT NUMBER(S) 49428-EL-SR.16		
12. DISTRIBUTION AVAILABILITY STATEMENT Approved for public release; distribution is unlimited.					
13. SUPPLEMENTARY NOTES The views, opinions and/or findings contained in this report are those of the author(s) and should not be construed as an official Department of the Army position, policy or decision, unless so designated by other documentation.					
14. ABSTRACT The operation of a traditional radio transmitter is limited by the frequency range over which the antenna input impedance can be conjugately matched to the power amplifier output impedance. This limitation is particularly strong when an electrically-small antenna is used. US patent number 5,402,133 "Synthesizer Radiating Systems and Methods" by Joseph Merenda suggested that this limitation can be overcome by driving the antenna directly with a digital version of the desired signal, such as that produced by a pulse-width modulator, through a pair of					
15. SUBJECT TERMS Antenna, communication system, electricallysmall, HF, pulsewidth modulation, switching amplifier, VHF					
16. SECURITY CLASSIFICATION OF:			17. LIMITATION OF ABSTRACT UU	15. NUMBER OF PAGES	19a. NAME OF RESPONSIBLE PERSON Dev Palmer
a. REPORT UU	b. ABSTRACT UU	c. THIS PAGE UU			19b. TELEPHONE NUMBER 919-549-4246

Report Title

Analysis of the Efficiency Improvement of a Directly-Driven Antenna-Based AM Transmitter

ABSTRACT

The operation of a traditional radio transmitter is limited by the frequency range over which the antenna input impedance can be conjugately matched to the power amplifier output impedance. This limitation is particularly strong when an electrically-small antenna is used. US patent number 5,402,133 “Synthesizer Radiating Systems and Methods” by Joseph Merenda suggested that this limitation can be overcome by driving the antenna directly with a digital version of the desired signal, such as that produced by a pulse-width modulator, through a pair of switching transistors, and using the antenna reactance to convert the digital input signal back into an analog radiated signal. The practicality of the Merenda method was demonstrated using an unmodulated carrier at 1 MHz by Palmer et al. in a paper presented at the 2008 Antenna Applications Symposium at Allerton. This work builds upon that result by demonstrating that an AM signal can in fact be encoded and transmitted with an electrically-small antenna by using this method, and by comparing the radiated power available from the directly-driven antenna (DDA) system to that of a traditional linear, conjugately matched transmitter.

Conference Name: Antenna Applications Symposium at Allerton

Conference Date: September 22, 2009

ANALYSIS OF THE EFFICIENCY IMPROVEMENTS OF A DIRECTLY-DRIVEN ANTENNA-BASED AM TRANSMITTER

Olusola O. Olaode¹, William T. Joines¹, and W. Devereux Palmer²

¹Department of Electrical and Computer Engineering,
Duke University, Durham NC 27708

²US Army Research Office, Durham NC 27703

Abstract-The operation of a traditional radio transmitter is limited by the frequency range over which the antenna input impedance can be conjugately matched to the power amplifier output impedance. This limitation is particularly strong when an electrically-small antenna is used. US patent number 5,402,133 “Synthesizer Radiating Systems and Methods” by Joseph Merenda suggested that this limitation can be overcome by driving the antenna directly with a digital version of the desired signal, such as that produced by a pulse-width modulator, through a pair of switching transistors, and using the antenna reactance to convert the digital input signal back into an analog radiated signal. The practicality of the Merenda method was demonstrated using an unmodulated carrier at 1 MHz by Palmer *et al.* in a paper presented at the 2008 Antenna Applications Symposium at Allerton. This work builds upon that result by demonstrating that an AM signal can in fact be encoded and transmitted with an electrically-small antenna by using this method, and by comparing the radiated power available from the directly-driven antenna (DDA) system to that of a traditional linear, conjugately matched transmitter.

1. Introduction

Modern wireless systems increasingly require more compact, portable, wide-band, and efficient transmitter architectures. In conditions where depletable power supply sources are used to power mobile devices, it is especially important that they are efficient. The research described in this paper is oriented towards the investigation of alternative transmitter architectures for US Army ground mobile wireless communications. Therefore, it is our expectation that the integration of this technology into actual Army radios, prove to be more efficient than the existing radios. Since 80% of the Army's

ground mobile wireless communication is conducted in the HF to VHF bands, the focus of this work, which is to improve the efficiency of the transmitter architecture, will center on the AM band where commercial components are readily available. A block diagram of a simple amplitude modulation (AM) transmitter is shown in the upper half of Figure 1.

The most notable in terms of efficiency and cost are the power amplifier and matching stages. Conventional AM transmitters have often employed class A, B, or AB linear amplifiers in the output stage, all of which are known to draw significant bias current to or from the load; thus, producing considerable power loss in the output power amplifier. In order to mitigate these losses, designers of wireless transmission systems have explored the use of higher-efficiency class-D amplifiers to replace the PA component in the traditional architecture shown in the upper half of Figure 1.

In comparison to class A (efficiency: 25% [1]) or class B (efficiency: 78.5% [1]), class D amplifiers can theoretically provide an efficiency of unity. Due to the non-linearity of the class-D amplifier, it is expected to yield a higher Total Harmonic Distortion (THD) compared with their linear counterparts. However, when designed carefully, an output filter improves the THD to <1% [1]. Therefore, the class D amplifier provides the optimum compromise between THD and efficiency.

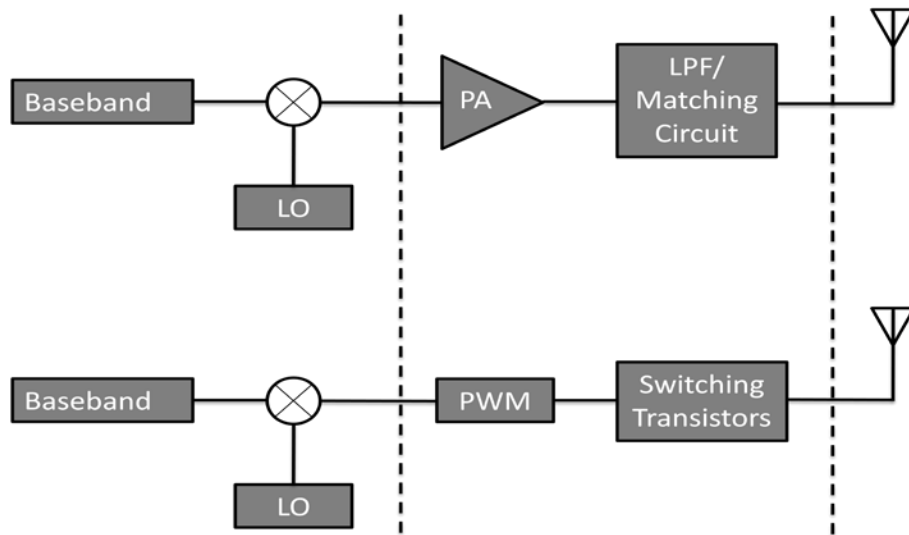

Figure 1. Block diagram showing the architectures of the (upper) conventional and (lower) digitally-driven antenna (DDA) AM transmitters. Glossary of terms - LO: Local Oscillator, PA: Power Amplifier, PWM: Pulse-Width Modulator, LPF: Low-Pass Filter.

Another approach taken by some researchers in improving the efficiency of a wireless transmitter circuit is to use a filter-less class D amplifier. Muggler et al. were able to obtain 86% power efficiency with their filter-free design [3]. However, in that application, the full-bridge configuration of the class D amplifier was used to differentially power the output speaker. This approach required pulse-width generation for each half-circuit of the H-bridge class D amplifier and pre-amplifier stage.

A dramatically different approach was proposed by Joseph T. Merenda (formerly of Hazeltine Corporation). Merenda (Patent # 5,402,133) proposed a system in which a radio signal can be digitized through a pulse width modulator and used to control the switching rate of a pair of complimentary transistors in a class D amplifier configuration. The signal is subsequently radiated by electrically small antenna systems (antennas whose physical sizes are small relative to excitation wavelength [2]). This approach was proven to result in improved bandwidth and efficiency in getting signals to the antenna and forms the basis of the work described in this report.

The lower block diagram in Figure 1 shows the architecture of the DDA system. Modulation of an information signal is performed in an identical manner in both the DDA and the conventional systems except that the power amplifier and low-pass filter/matching network stages in the conventional architecture are replaced with a pulse-width modulator and complimentary switching transistors in the DDA architecture. Details on the contributions of the PWM/switching transistor networks combinations are to be presented later in the paper.

2. Digitally Driven Antenna Circuit Design and Architecture

2.1 Pulse Width Modulator

The Pulse Width Modulation (PWM) in the DDA architecture is performed by a comparator amplifier as shown in Figure 2. An audio signal that has been modulated with a high-frequency local oscillator (Modulated Carrier, V_{MC}) is driven into the positive terminal of the comparator and sampled through a much-higher frequency sawtooth waveform (Reference, V_{REF}). The output of the comparator is low when the magnitude of the reference exceeds the baseband and high otherwise; hence resulting in the pulse-width modulation. For a given input level, the sawtooth frequency determines the frequency of the comparator's output [1] while the baseband frequency determines its duty cycle. Therefore, for an accurate signal reconstruction, the frequency of the reference waveform should be at least ten times that of the baseband [1].

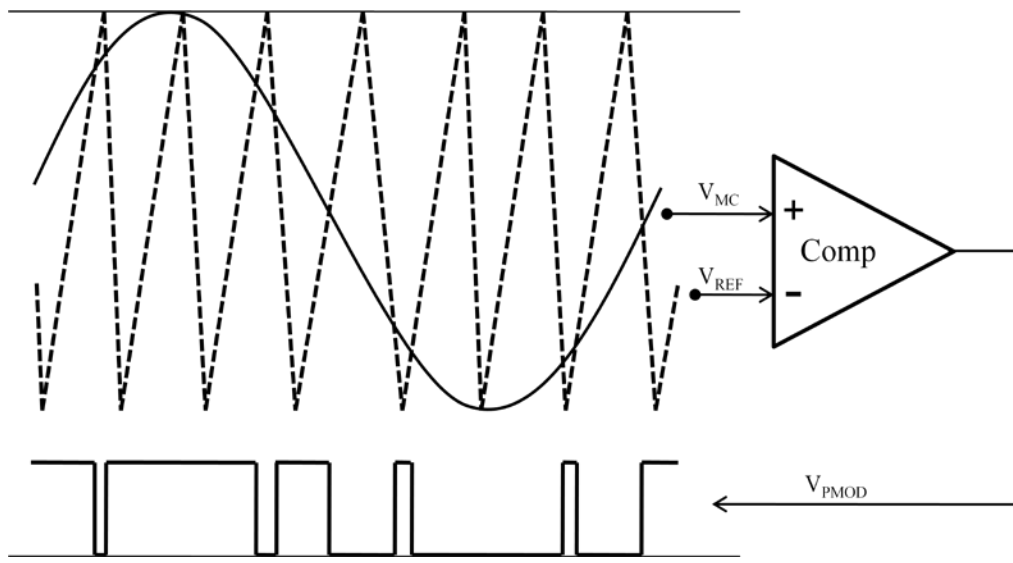

Figure 2. Pulse Width Modulation stage. *Glossary of terms* - Comp: Comparator

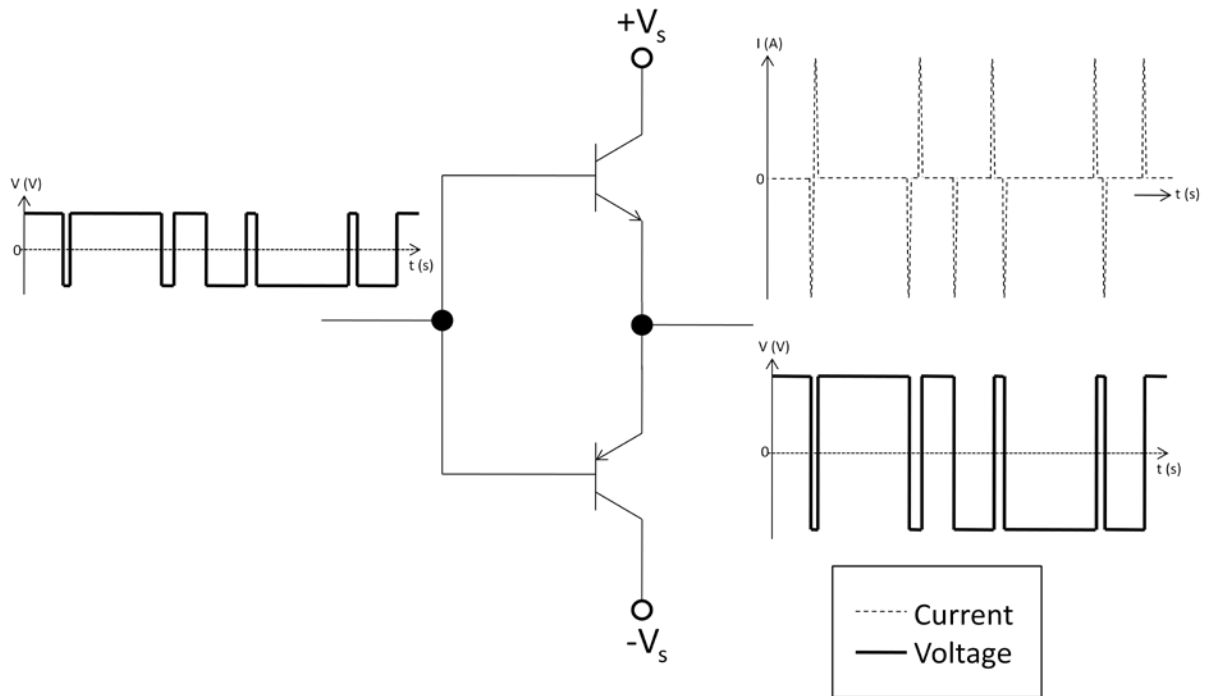

Figure 3. Class D amplifier switching amplifier stage.

2.2 Switching Transistor Network

The digitized version of the modulated carrier signal from the PWM stage discussed in the previous section is driven directly into a class D amplifier shown in Figure 3. The class D amplifier used in this study comprises of a pair of complimentary bipolar junction transistors driven either in cutoff or saturation. Therefore, the output is a copy of the input pulse train but at a higher current level, oscillating between the amplifier's rail voltages ($+V_S$ and $-V_S$). Furthermore, current spikes are generated only during the transition times of the voltage signal. The information contained in the modulated carrier signal and encoded in the separation of the current spikes is converted to analog by the antenna reactance, radiated and recovered at the receiver end. Because current flows to the antenna only in very short bursts, the power efficiency of the transmitter output stage may be increased.

2.3 Transmit and Receive Antenna Selection

This section covers both the dipole antenna used as a transmitter and a ferrite rod loop antenna used as a receiver. Geometrically small and portable radios require electrically small antennas. A half-wavelength dipole antenna at resonance was used for this study (see Figure 5). The electrical length was $\lambda/3300$ at 1MHz carrier frequency. Such dipole antennas can be represented by resonant RLC circuits [4], [5], [6], [7]. For example, [7] suggested that a dipole antenna can be represented with a four-element equivalent circuit in Figure 4. Calculation of the equivalent impedance seen looking in Figure 4 suggests a much higher capacitive component and a very small radiation resistance, which is expected in electrically small antennas.

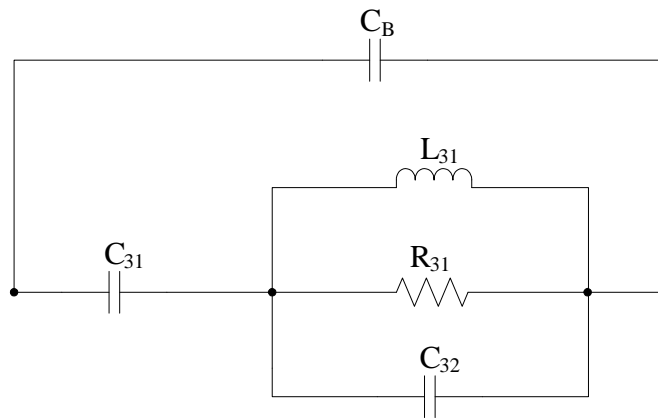

Figure 4. R-L-C representation of a Dipole Antenna. Adapted from [7].

Based on the equations provided in [7] and reproduced here for convenience, theoretical values of C₃₁, L₃₁, R₃₁, C₃₂ were calculated and are shown below.

$$C_{31} = \left\{ \frac{12.0674h}{\log\left(\frac{2h}{c}\right) - 0.7245} \right\} pF \quad (1a)$$

$$C_{32} = 2h \left\{ \frac{0.89075}{[\log(2h/c)]^{0.8006} - 0.861} - 0.02541 \right\} pF \quad (1b)$$

$$L_{31} = 0.2h \{ [1.4813 \log(2h/c)]^{1.012} - 0.6188 \} \mu H \quad (1c)$$

$$R_{31} = \{ 0.41288 [\log(2h/c)]^2 + 7.40754 (2h/c)^{-0.02389} - 7.27408 \} k\Omega \quad (1d)$$

$$C_{31} = 0.5468 pF \quad (2a)$$

$$C_{32} = 0.115 pF \quad (2b)$$

$$L_{31} = 0.0179 \mu H \quad (2c)$$

$$R_{31} = 0.6952 k\Omega \quad (2d)$$

Analysis of the total impedance of the circuit in Figure 4 using the theoretical values of C₃₁, L₃₁, R₃₁, C₃₂ obtained in equations (2a)-(2d) suggests C₃₁ as dominant. Hence, L₃₁, R₃₁, C₃₂ can be ignored. The capacitance introduced by the balun is estimated as that of two concentric hollow cylinders 8cm in length and with 0.55cm radius and 0.17cm thickness, as calculated in equation (3).

$$C_B = \frac{2\pi\epsilon_0}{\ln\left(\frac{a}{c}\right)} \cdot b = \frac{2\pi \cdot 8.854 \cdot 10^{-12}}{\ln\left(\frac{0.0055}{0.0017}\right)} \cdot 0.08 = 3.8 pF \quad (3)$$

For the receive antenna, we used a 470μH antenna. Therefore, a combination of both transmit (0.5468pF capacitor) and receive (470μH inductor) antennas constitutes a filter; albeit the first few harmonics are still permitted and a dedicated filter may be necessary based on the application environment.

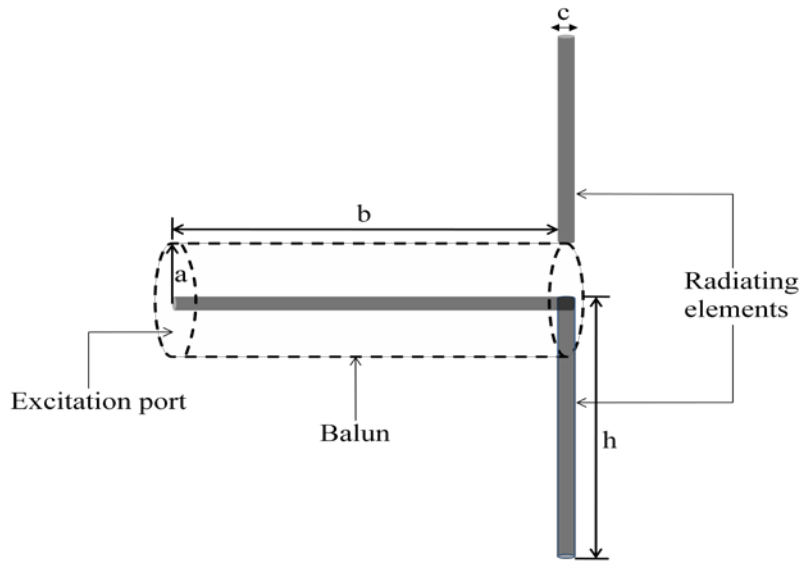

Figure 5. 3-D sketch of the Dipole Antenna used for this study. $h = 4.55\text{cm}$, $c = 0.17\text{cm}$, $a = 0.55\text{cm}$, $b = 8\text{cm}$. Radiating elements and balun are made of copper. SMA connector at the excitation port facilitates interfacing to circuit.

3. Measurement Setup

As indicated earlier, the goal of the work described in this report is to investigate potential efficiency improvement of the DDA over conventional transmitter architectures. Therefore, it is important that both architectures are kept identical except in the output stage, and that measurements are made under the same conditions. Figures 6 and 7 depict the two architectures. In both cases, an audio signal with bandwidth approximately 20 kHz is coupled from a music player in to an AM transmitter kit, manufactured by Ramsey Electronics, LLC. The transmitter circuit is optimized to produce an amplitude-modulated carrier sine wave at a frequency of approximately 1MHz. A copy of the schematic has been provided in Figure 9 for reference purposes.

In the conventional AM transmitter circuit (upper half of Figure 8), the carrier-modulated sine wave is amplified with a low-power audio amplifier (LM386) commonly employed in commercially-available AM radios and transmitted to a low pass filter prior to propagation by the transmit dipole antenna. The low pass filter facilitates a further suppression of spurious content in the received frequency spectrum. A highly-inductive receive antenna ($470\mu\text{F}$) commonly in use in commercial AM radios was placed at a

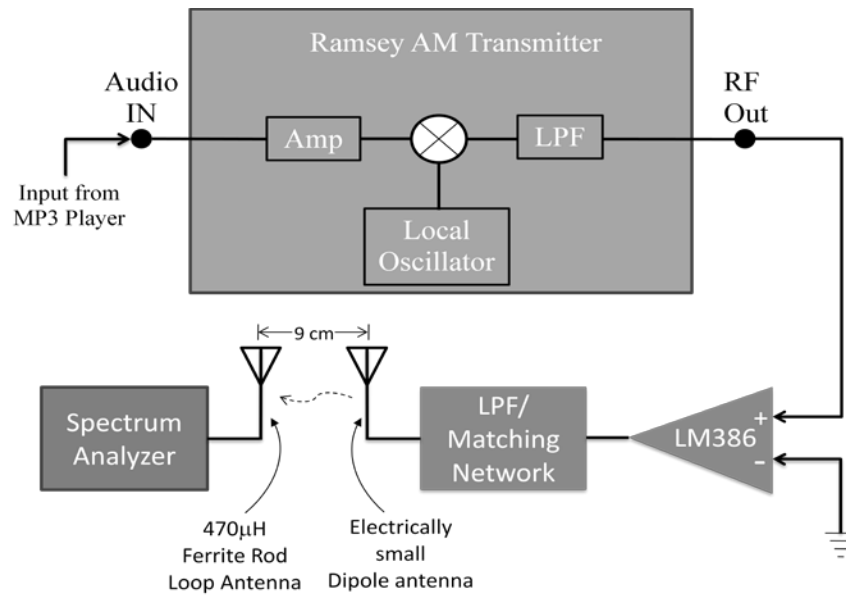

Figure 6. Measurement setup of the Conventional AM transmitter architecture. *Glossary of terms* – LPF: Low Pass Filter, Amp: Amplifier. Ramsey AM Transmitter refers to the AM1C AM transmitter kit produced by Ramsey Electronics.

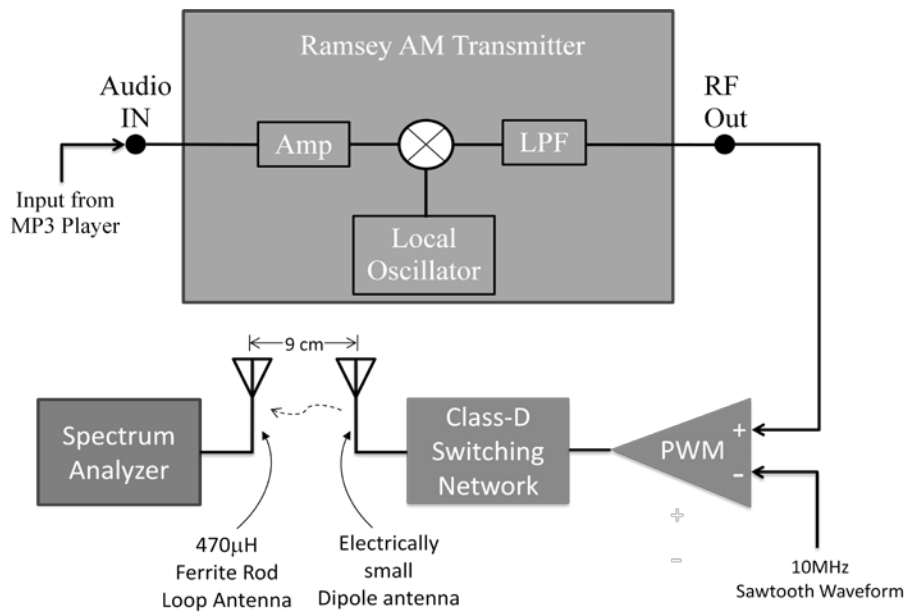

Figure 7. Measurement setup of the DDA AM transmitter architecture. *Glossary of terms* – LPF: Low Pass Filter, Amp: Amplifier. Ramsey AM Transmitter refers to the AM1C AM transmitter kit produced by Ramsey Electronics.

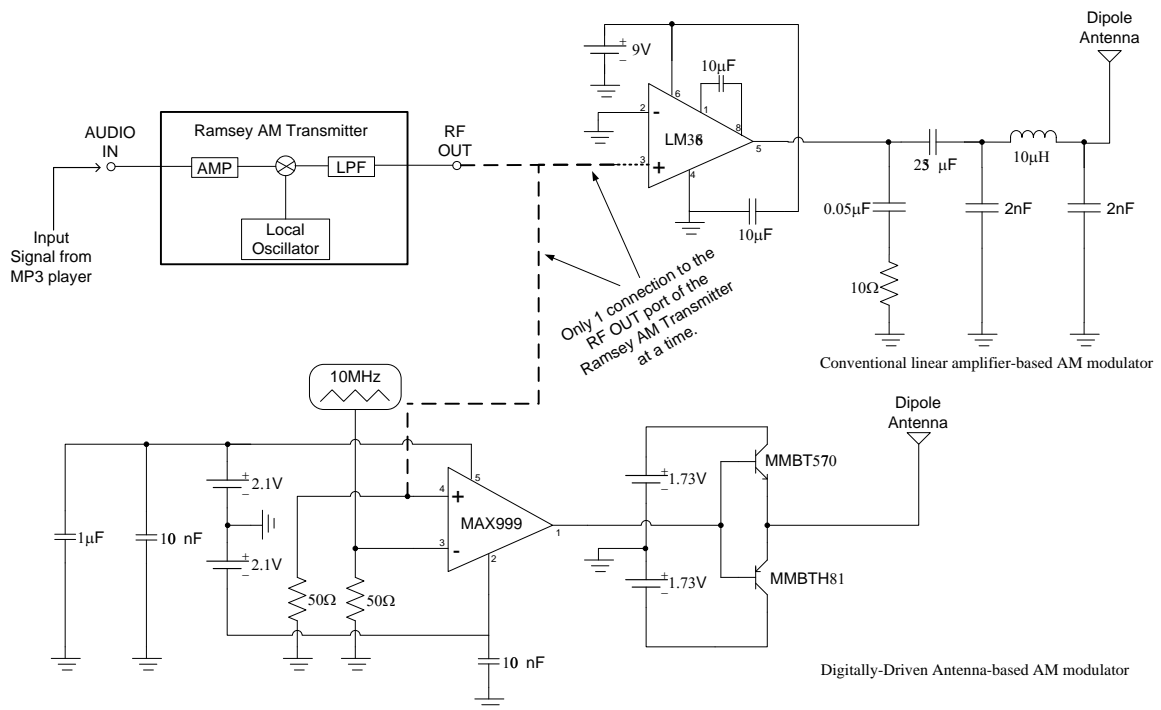

Figure 8. Schematic-level representation of Figures 6 and 7. Ramsey AM Transmitter refers to the AM1C AM transmitter kit produced by Ramsey Electronics.

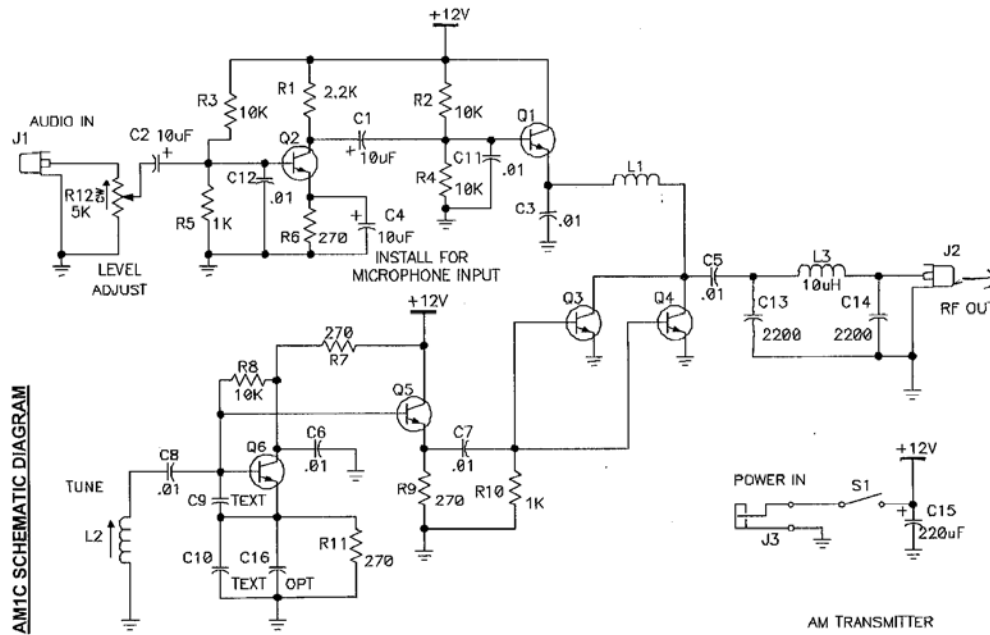

Figure 9. Schematic of the Ramsey AM Transmitter. Courtesy: Ramsey Electronics, LLC.

distance of 9cm for both transmit architectures. The measurement results are discussed in the following section.

4. Results

To qualitatively compare the performance of the two AM transmitter architectures, the modulated 1MHz carrier signal was set to a given power level and the signal received on the portable tabletop AM radio receiver was tuned to the carrier frequency. The AM radio was gradually moved away from the dipole (transmit) antenna along the plane of the peak broadside radiation pattern. It is noteworthy to mention that both transmitters reproduced the signal from the music player in a clear, recognizable way although the DDA-based transmitter yielded a much higher-fidelity reproduction of the original signal despite the fact that the DDA architecture does not include an explicit filtering mechanism on the output. In addition, the broadcast signal still could be heard a few feet beyond where the signal produced by the conventional transmitter architecture became unintelligible. Given that the testing conditions for the two architectures were otherwise identical, the observation described above signifies that more of the modulated carrier signal power is radiated in the DDA case than in the conventional circuit case. Therefore, these qualitative observations strongly suggest that the DDA transmitter produces a more efficient coupling of the signal to the electrically-small transmit antenna.

To quantify the relative performance, the radiated frequency spectrum was measured at the receive antenna end placed at a distance of 9 cm using each architecture. The distance of 9 cm while arbitrary, is well in the far field region of the transmit antenna as estimated by Equation 4 [10] and also minimizes interference from the test equipment and active transmission lines. The power magnitude at the carrier frequency of 1 MHz was measured and compared in both cases. Figure 9 indicates a power magnitude of -81.2 dBm or 7.6 pW in the conventional AM transmitter case while Figure 10 indicates a power magnitude of -70.1 dBm or 97.7 pW in the DDA transmitter case. This represents an improvement of 11 dB or 13X with the DDA transmitter in contrast to the non-DDA transmitter, while also maintaining a smaller visual signature (layout).

$$r_{ff} = \frac{2D^2}{\lambda} \quad (4)$$

Where r_{ff} is radial distance from the dipole antenna, D is the largest dimension of the antenna and λ is the smallest wavelength radiated.

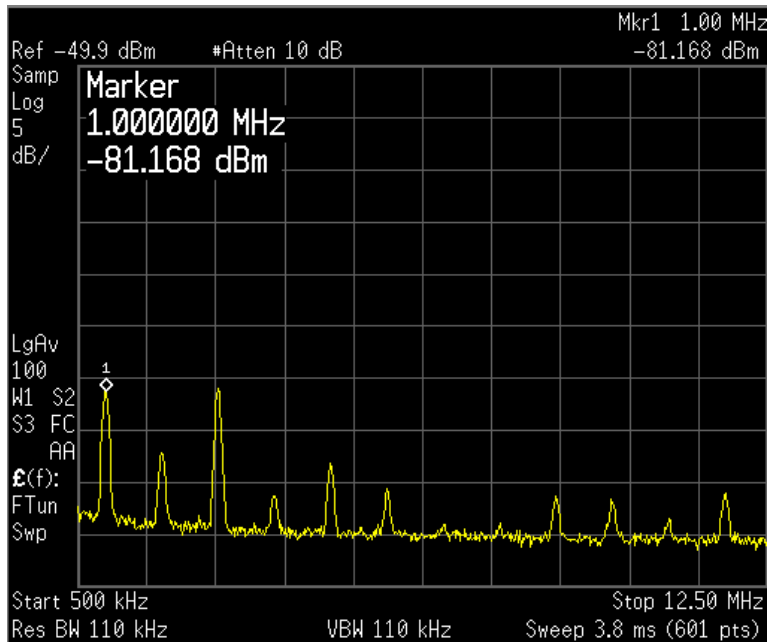

Figure 9. Radiated frequency spectrum observed at 9 cm from the transmit dipole antenna using the conventional AM circuit architecture.

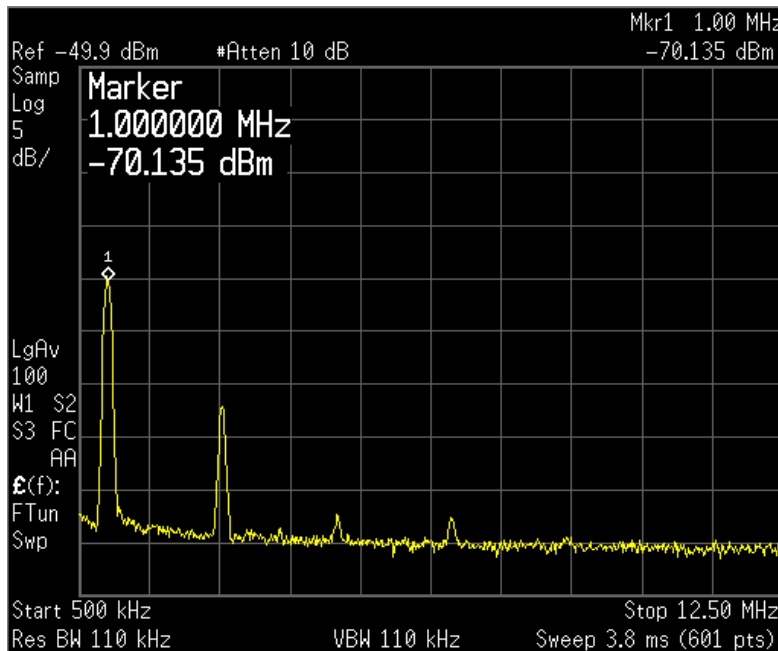

Figure 10. Radiated frequency spectrum observed at 9 cm from the transmit dipole antenna using the DDA architecture.

5. Conclusion and Future Research

The potential for the DDA architecture to break the performance bounds of the traditional transmitter architecture make it an attractive research area for potential use in US Army ground mobile wireless communications. In this work, the ability of the DDA architecture to transmit an AM signal at 1 MHz with higher power than can be produced by the conventional transmitter architecture strongly suggests that the DDA architecture produces more efficient coupling of the modulated carrier to an electrically-small transmit antenna. Many research questions remain, including analysis and control of the spectral content of the radiated signal, comparison of the relative efficiency, size, and cost of the DDA and conventional architectures, PWM clock rate and stability requirements as a function of modulation complexity, and the effect of the transmit antenna design on the filtering properties of the DDA architecture. The DDA architecture also introduces more fundamental questions, potentially requiring new definitions for standard antenna terms such as “match” and “near field” in the DDA context where the assumptions used in analysis of steady state operation no longer apply.

6. Acknowledgement

This work was supported in part by the US Army Research Laboratory and the US Army Research Office under Agreement Number W911NF-04-D-0001, Delivery Order 0003.

7. References

- [1] *Class D Audio Amplifiers Save Battery Life*, Maxim Integrated Products, Sunnyvale, CA, AN1760, 2002.
- [2] J.T. Merenda, “Synthesizer Radiating Systems and Methods,” U.S. Patent 5 402 133, March 28, 1995.
- [3] P. Muggler, W. Chen, C. Jones, P. Dagli, and N. Yadzi, “A Filter Free Class D Audio Amplifier with 86% Power Efficiency,” *IEEE Symposium on Circuits and Systems*, vol. 1, pp. 1036-1039, May 2004.
- [4] R. G. Brown, R. A. Sharpe, W. L. Hughes and R. E. Post, *Lines, Waves, and Antennas*, New York: Wiley, 1973, pp. 339-346.
- [5] H. Jasik, *Antenna Engineering Handbook*, New York: McGraw-Hill, 1961, pp. 2-11.

- [6] R. W. P. King, *The Theory of Linear Antennas*, Cambridge: Harvard University Press, 1956, p. 176.
- [7] T. G. Tang, Q. M. Tieng, and M. W. Gunn, "Equivalent circuit of a dipole antenna using frequency-independent lumped elements," *IEEE Trans. Antennas and Propagation*, vol. 41, no. 1, pp. 100–103, January 1993.
- [8] S. B. Wang, A. M. Niknejad, and R. W. Brodersen, "Modeling omnidirectional small antennas for uwb applications," in *Conf. Rec. IEEE Antennas and Propagation International Symposium*, 2004.
- [9] W.D. Palmer, W.T. Joines, and S.D. Keller. "Transmission of a 1 MHz Signal Using a Directly Driven Antenna System," *Antenna Applications Symposium at Allerton*, Monticello IL, September 16-18, 2008.
- [10] W. L. Stutzman, G. A. Thiele, *Antenna Theory and Design*, New York: John Wiley & Sons, Inc, 1998, p. 413.