

REPORT DOCUMENTATION PAGE

Form Approved
OMB No. 0704-0188

Public reporting burden for this collection of information is estimated to average 1 hour per response, including the time for reviewing instructions, searching existing data sources, gathering and maintaining the data needed, and completing and reviewing this collection of information. Send comments regarding this burden estimate or any other aspect of this collection of information, including suggestions for reducing this burden to Department of Defense, Washington Headquarters Services, Directorate for Information Operations and Reports (0704-0188), 1215 Jefferson Davis Highway, Suite 1204, Arlington, VA 22202-4302. Respondents should be aware that notwithstanding any other provision of law, no person shall be subject to any penalty for failing to comply with a collection of information if it does not display a currently valid OMB control number. **PLEASE DO NOT RETURN YOUR FORM TO THE ABOVE ADDRESS.**

1. REPORT DATE (DD-MM-YYYY) May 1990		2. REPORT TYPE Conference paper		3. DATES COVERED (From - To)	
4. TITLE AND SUBTITLE See report.				5a. CONTRACT NUMBER	
				5b. GRANT NUMBER	
				5c. PROGRAM ELEMENT NUMBER	
6. AUTHOR(S) See report.				5d. PROJECT NUMBER	
				5e. TASK NUMBER	
				5f. WORK UNIT NUMBER	
7. PERFORMING ORGANIZATION NAME(S) AND ADDRESS(ES) See report.				8. PERFORMING ORGANIZATION REPORT NUMBER	
9. SPONSORING / MONITORING AGENCY NAME(S) AND ADDRESS(ES) See report.				10. SPONSOR/MONITOR'S ACRONYM(S)	
				11. SPONSOR/MONITOR'S REPORT NUMBER(S)	
12. DISTRIBUTION / AVAILABILITY STATEMENT Distribution Statement A - Approved for public release; distribution is unlimited.					
13. SUPPLEMENTARY NOTES Presented at the IEEE 1990 National Aerospace and Electronics Conference (NAECON 1990) held in Dayton, Ohio, on 21-25 May 1990.					
14. ABSTRACT See report.					
15. SUBJECT TERMS					
16. SECURITY CLASSIFICATION OF:			17. LIMITATION OF ABSTRACT UU	18. NUMBER OF PAGES	19a. NAME OF RESPONSIBLE PERSON
a. REPORT Unclassified	b. ABSTRACT Unclassified	c. THIS PAGE Unclassified			19b. TELEPHONE NUMBER (include area code)

RADC SCAT
AUTOMATED SNEAK CIRCUIT ANALYSIS TOOL

Edward L. DePalma
Rome Air Development Center (RADC/RBER)
Griffiss AFB, NY

ABSTRACT

Standard Sneak Analysis procedures are costly from a time, money and personnel perspective. The processing of design data available only during the latter portions of the development cycle are highly labor intensive and difficult to institute a design change. Automated techniques for sneak analysis have been developed by several contractors for the workstation environment, but are either not completed or are proprietary. In fact, some of these techniques are only a subset of the sneak analysis procedure, namely design concerns. The Sneak Circuit Analysis Tool (SCAT) overcomes many of these deficiencies by providing a personal computer based system for real time identification (during the actual design phase) of sneak paths and design concerns. The tool utilizes an expert system shell to assist the analyst so that prior experience with sneak analysis is not necessary for performance. Both sneak circuits and design concerns are targeted by this tool with both digital and analog circuits being examined. SCAT focuses the analysis at the assembly level rather than the entire system so that most sneak problems can be identified and corrected by the responsible design engineer in a timely manner.

INTRODUCTION

... 10 - 9 - 8 ...

On November 21, 1961 the new Mercury-Redstone rocket was scheduled for launch.

... 7 - 6 - 5 ...

This was the first launch of the Redstone design.

... 4 - 3 - 2 ...

The Redstone circuitry had passed all of the required tests and screens to insure the rocket's survival in the space environment.

... 1 - 0 - ABORT.

Before the Redstone rocket could get more than a few inches off the ground, the mission was aborted via the engine cutoff circuit. The cause of this abort was not a part or component failure; it was the presence of a sneak circuit path. This condition is illustrated in Figure 1 which depicts the portion of the blockhouse and missile circuitry involving the sneak. As shown in the figure, the normal sequence of events is for launch command relay K1 to be triggered, enabling battery B1 to power the missile ignition coil and the blockhouse ignition indicator. However, if upon launch the tail plug umbilical carrying ground return P3 separated before the control umbilical, current flowing through the ignition indicator would continue through diode D2 and supply power to the engine cutoff coil. This sequence of events actually did occur. It could have been prevented by routing the power and return lines through the same connector. By definition, sneak circuits are defined as "latent paths which cause occurrence

of unwanted functions or inhibit desired functions, assuming all components are functioning properly."

DEFINITION OF PROBLEM

The sneak circuit condition can be broken down into four groups:

(1) sneak paths are latent current paths that cause an unwanted function to occur or inhibit a desired function independent of component operation.

(2) sneak timing, which can result from incompatible hardware or logic sequences, can result in inappropriate system response.

(3) sneak labels arise from the lack of precise nomenclature or instructions on controls or operating consoles that lead to erroneous operator actions.

(4) sneak indicators, which can result from improper connection or control of display devices and their sensors, can show false or ambiguous system status.

It should be noted that a sneak circuit failure is not influenced by temperature, vibration, part stress, or wearout factors. None of the common causes of failures apply because this type of weakness is designed into the system and is not related to the environment. Correcting potential sneak circuits requires an extensive study of a project's entire circuit network. This study would have to identify the effect of every possible current and timing path, assure that all labels and indicators are correct for all possible situations, and warn of any existing weaknesses in the circuit design. There are specialists in the area of sneak circuit analysis who will perform such a study, but there are drawbacks to this method of dealing with the sneak circuit problem.

The cost of an outside specialist performing a sneak circuit analysis is threefold. Time is the first concern. The amount of time needed by an outside contractor to complete an in-depth study on the scale of a sneak analysis could easily be measured in months rather than weeks (depending on the size of the project). Also, analysis done by this method would require a high level design. Such a design would only be available late in a project development which is not the place for extended, time consuming studies. Secondly, the cost of performance restricts many from adding a sneak circuit analysis to their reliability programs. The funds needed to retain a contractor for the required amount of time would put an unacceptable strain on most project budgets. Finally, there are the designers who will be provoked when a completed model is brought back to the drawing board to correct hidden sneak paths. Time, money and personnel are wasted by this process. An alternate method is now introduced by Rome Air Development Center (RADC), and SoHaR Incorporated. RADC and SoHaR have created SCAT.

SOLUTION

SCAT is an acronym for the Sneak Circuit Analysis

Tool. SCAT is a software package available through RADC that automates the sneak circuit analysis process. Using a personal computer, the design engineer runs the SCAT package to find and correct the sneak paths hidden in his/her design. If SCAT is used there is no need for an outside contractor. The analysis is performed by the actual designers of the system in the design phase where this type of study would be most effective. High level drawings are not required, so any necessary alterations will be timely and less costly.

SCAT uses the Electronic Data Interchange Format (EDIF) net list from the schematic capture package OrCAD and an M1 expert system logic shell. (These two programs represent the only purchases necessary.) Using OrCAD the designer simply enters his/her circuit in the SCAT package for analysis. The circuitry is entered as is with no rearranging needed. SCAT will accept both analog and digital designs. The time required to complete the analysis depends on the complexity of the circuit, but even the most complex circuits will require only a few minutes. For very large circuit networks, the SCAT program allows for a sectional analysis.

When sneak analysis is done manually the procedure is to rewrite the circuit to be analyzed in topological form using network trees. This form exposes patterns in the circuit interconnections that are susceptible to sneak paths. The most significant of these patterns are listed in Figure 2.

Performing this type of a transformation and interpreting the results is a painstaking process that puts sneak analysis out of the designer's reach and

into the lab of specialists. Contractors specializing in SCA often use an automated system to transform the circuits directly but these systems are generally proprietary or are not available for outside use. To overcome these difficulties the SCAT program works directly from the circuit blueprint and any transformations are handled within SCAT, with no external expertise required.

When SCAT has the circuit in a workable format the program then scans the circuit for sneaks using a built in clue list. The clue list represents a grouping of common circuit design weaknesses that were winnowed from a list of 200 plus clues. SCAT contains a total of 19 guideline clues of which 17 are design concerns. If one of the design concerns is diagnosed by SCAT the user is supplied with a warning message, an explanation of the problem, and finally a recommended solution to the problem. SCAT also identifies reverse current sneak paths by analyzing all possible circuits and component states from a predetermined source and sink. When a reverse current path is discovered SCAT lists the sequence of components affected allowing the user to trace the path through the schematic and make any necessary design adjustments. The last clue is an OrCAD feature which performs a power check on the circuit.

A prerequisite requirement that is needed for operating the SCAT system is an understanding of the operation of the circuit and devices used. The reason for this requirement is that SCAT will occasionally query the operator for information to complete the analysis. Facts such as; make-before-break switch states, open capacitor circuits, analog or digital devices may be requested.

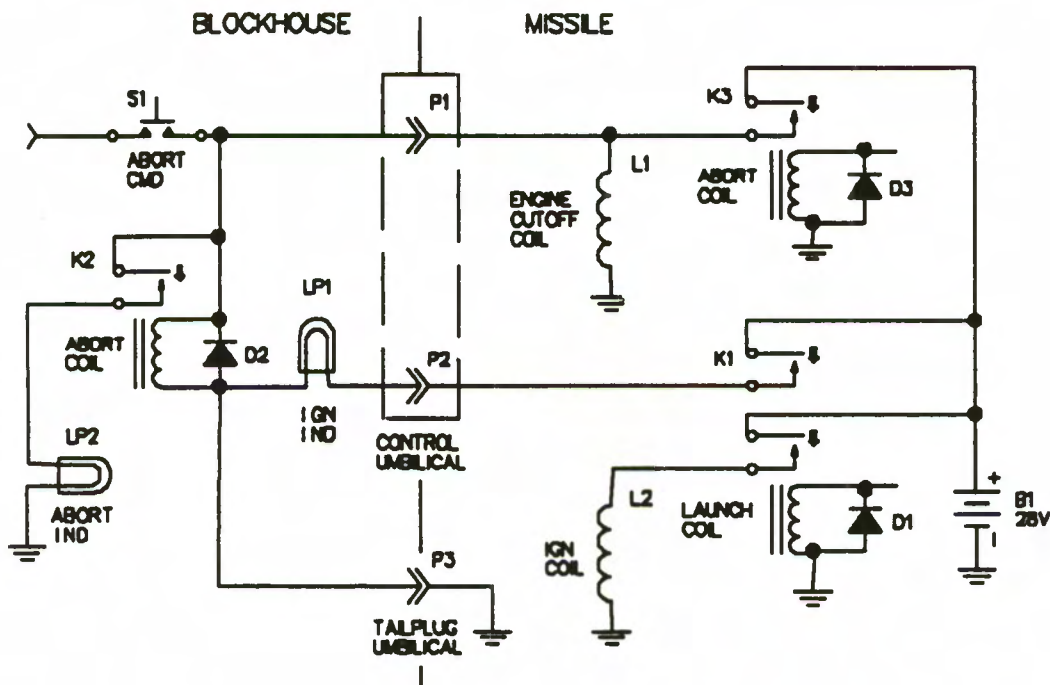

FIGURE 1. MERCURY-REDSTONE ROCKET LAUNCH CIRCUITRY

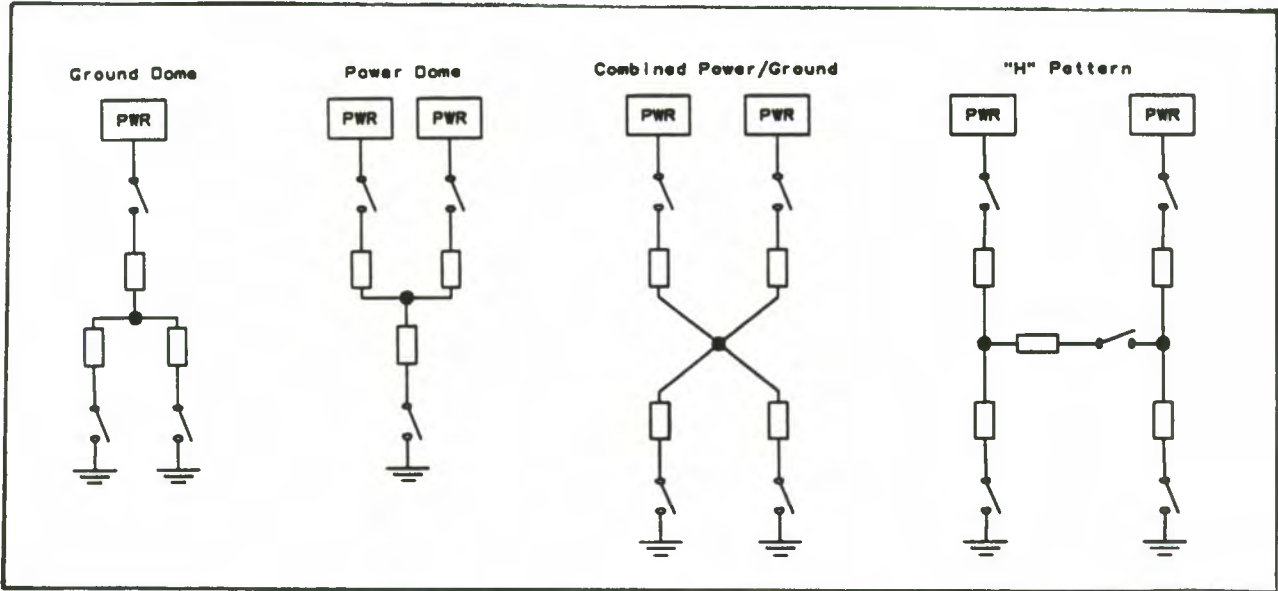

FIGURE 2. TOPOGRAPHICAL DIAGRAMS

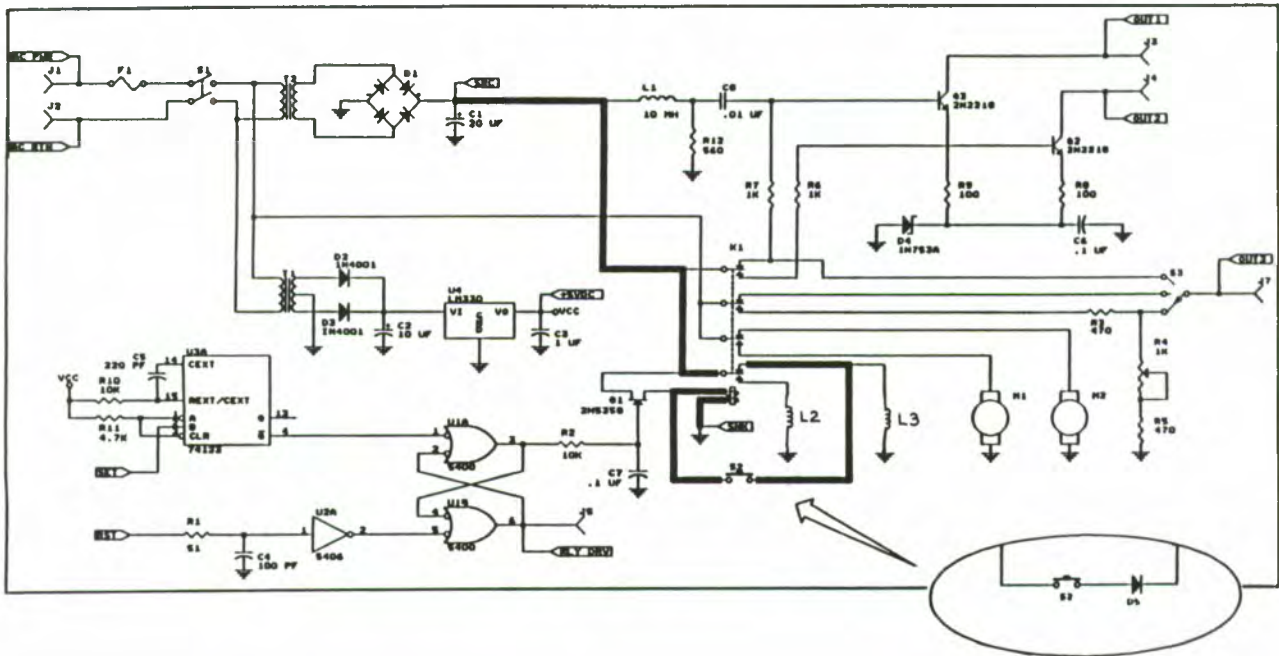

FIGURE 3. SNEAK CIRCUIT EXAMPLE - WEAPONS CONTROL CIRCUIT

One limitation with the SCAT program is the size of the analysis. As presently conformed the program will only analyze circuits composed of 300 or less components. Larger circuits require sectional analysis which means knowledge of the design is necessary to separate overlapping functions.

Designs that are updated, or reworked following a SCAT analysis can easily be reentered into SCAT to assure that no new sneaks have been created. The OrCAD schematic capture package makes any editing or alterations a simple process.

OrCAD/STD III has a library of over 3700 unique parts and is flexible enough to allow the user to create his/her own custom parts if necessary. With over 200 hierarchical levels, OrCAD can be used to represent the most complex system designs. OrCAD speeds up the repetitive process of continuously entering the same parts by supplying the user with over 100 keyboard macros for parts appearing many times over in a system's design. Though not necessary for the SCAT program's operation, the OrCAD package has many supplementary features available separately that may aid the designer in reaching the optimum design.

EXAMPLE

Figure 3 shows an example of a circuit board level sneak circuit failure. The circuit is a reconstruction from a weapons control circuit so that a potential sneak path can be demonstrated. The function of this circuit is the control of the arming coil.

L2, the arming coil, is initially activated through transistor Q1. Switch S2 is designed to override the arming command and shut off coil L2. As shown the sneak concern exists when transistor Q1 is off and the disarming order is given by closing switch S2. Under this set of conditions relay K1 is allowed to oscillate and periodically activate the arming coil L2. When this circuit was analyzed by SCAT for a reverse current sneak paths, this problem was identified in seconds. The solution given by SCAT was the insertion of a diode in the switch relay path to prevent the reverse current flow.

The cost of inserting a diode into a design is minuscule when it is done early in the design phase. As the design grows and progresses further along towards actual production the cost of any changes increases at an alarming rate. A sneak analysis study performed by Boeing (ref 5) shows that the cost of change from design to full scale development increases by a factor of five. When a sneak circuit is passed on into the field the cost of a change increases by at least a factor of twelve. If the only action required is a minor adjustment then a product developer is fortunate, however any design alteration at this stage is costly. If sneak circuit analysis had been incorporated into the design process, these costs would not have been incurred.

If the improvement is made in the design process, then the efficiency is increased and quality of work brought to a higher level, so that the overall process benefits. With the introduction of SCAT, the designer has a tool that will pinpoint weaknesses or soft spots in his/her design. SCAT guides the user toward the best design possible by making designers aware of potential flaws in the approach. The SCAT

package improves both the product and personnel performances, in some situations the latter may be the more advantageous of the two.

UPGRADE

For all of SCAT's obvious qualities there is one drawback. The SCAT version available today is only a prototype of a fully functional, completely automated sneak circuit analysis package. Future work is needed to expand the progress already made with this version of SCAT. Projected modifications to increase the scope of the SCAT package are given below:

1. Upgrade of the Expert System - The M.1 expert system would be replaced with a C-based expert system. Such a change would enable the expert system shell to be called from programs written in the C language. The upgrade of the expert system would also allow SCAT to use an array of powerful options present in more advanced systems.

2. Schematic Capture Upgrade - The new schematic capture program being considered would highlight the sneak path on the circuit diagram. The user would not have to trace a list of components, the path would be displayed directly on the circuit.

3. Database Interface - A database would be created to answer many of the computer queries presently answered by the user. By creating this database SCAT will be more self contained and available to users who are not as familiar with the interconnections of the circuit.

4. Expansion of Design Concerns - Presently SCAT identifies seventeen design concerns. This would be expanded to eighty. These eighty clues are presently listed in MIL-STD-1543B. With the inclusion of all eighty clues, SCAT would directly support the referenced standard.

5. Expansion of SCAT to workstations - By upgrading the schematic capture package and expert system the SCAT package could be formatted for use on a workstation such as the Sun SPARCstation.

The focus of the SCAT project now is to test this concept on actual hardware configurations to see what problems are revealed so that corrections can be introduced into the SCAT program. While working with the SCAT package, RADC will have the in-house capability to perform sneak circuit analysis on a variety of systems. The SCAT package is available through RADC, copies are limited and written requests should be sent to:

RADC/RBE
ATTN: RADC SCAT
Griffiss AFB NY 13441-5700

CONCLUSION

It is well known that sneak circuits are present in most designs, the only question is whether they will adversely affect a system and what action to take if they do. The SCAT program identifies the sneak circuits to the designer and he/she then decides what course of action is necessary. Manual analysis or proprietary methods are too costly for most programs. The SCAT package is the logical alternative. SCAT is available through RADC. Written comments or suggestions on the SCAT project are encouraged and should be sent to:

Edward DePalma
RADC/RBER, Bldg 3
Griffiss AFB, NY 13441-5700

REFERENCES

1. Boeing Aerospace Company, Houston TX
"Sneak Analysis Summary"
2. Tyrone Jackson, TRW, Redondo Beach CA
"Integration of Sneak Circuit Analysis with FMEA"
3. Sverdrup Technology Inc, AEDC Group
Arnold Air Station TN
"Sneak Circuit Analysis"
Sverdrup Training Notes 6000-Bj
4. SoHaR Inc, Los Angeles CA
"White Paper on Upgrading SCAT"
5. Davey L. Buratti and Sylvia G. Godoy
Boeing Aerospace Company, Houston TX
"Sneak Analysis Application Guidelines"
RADC-TR-B2-179
AD# A-118479
6. Jeff Miller, SoHaR Inc, Los Angeles CA
"Sneak Circuit Analysis for the Common Man"
RADC-TR-B9-223
AD# A-215275
7. Jeff Miller, SoHaR Inc, Los Angeles CA
"Integration of Sneak Analysis with Design"
Vol I & II
TR Number - To be determined
AD Number - To be determined