



Coastal Engineering Technical Note



MODIFICATION TO SEA DATA WAVE GAGES FOR COASTAL USE

PURPOSE: The Sea Data/Pacer self recording wave gages are susceptible to failure caused by a clogged pressure port when used in coastal waters. A modification can be made to the gage to eliminate this failure mode and greatly improve the reliability of the gages.

INTRODUCTION: The Sea Data wave gage is used extensively by the Corps of Engineers to obtain wave measurements. It measures water pressure with a transducer and records the time series of pressure fluctuations on an internal cassette tape. When deploying internal recording gages, failure of the gage for any reason cannot be detected until after recovery. If failure occurs, the costs of deploying and recovering the instrument may be wasted. Failure to obtain the required data may in turn have other adverse consequences.

There are many failure modes for any type of instrument, ranging from electronic to structural damage to human error. The best defense against these is a thorough and methodical system of tests and checkouts prior to deployment. The failure that is the topic of this Technical Note is due to a clogged pressure port leading to the transducer inside the gage. All Sea Data wave gages are designed to transmit external pressure fluctuations to this transducer through a thin (1 mm) stainless steel tube open at one end to the ambient water through a stainless swaged tube fitting. The tube and fitting are filled with a silicone oil. The gage design relies on the small tube size and viscosity to prevent the oil from leaking out. The gage was originally developed for use in deep ocean deployments suspended by buoys. These waters are usually clear (i.e., free of suspended sediment), wave periods are long and biologic activity relatively light.

Coastal waters, in contrast, are usually high in suspended sediment and biologic activity. These two agents can result in full or partial blocking of the fitting or the tube. Biofouling is the most common in warmer waters. Marine organisms attach themselves to the pressure port fitting and eventually seal off the opening. The larger organisms, such as barnacles, are apparent when the gage is removed. They are cleaned from the fitting as part of the routine maintenance. If the port was completely blocked prior to recovery, the resultant flat output signal will be evident in the data analysis. It is not always evident at what point the data were affected before complete blockage occurred, making the validity of the entire data set questionable. When the blockage is restricted to the fitting, it only affects that particular deployment, and the gage can be assumed to be in working order when cleaned and re-deployed.

The thin tube connecting the port to the transducer is also prone to clogging. The oil can be partially or even completely lost over the deployment interval

Report Documentation Page

Form Approved
OMB No. 0704-0188

Public reporting burden for the collection of information is estimated to average 1 hour per response, including the time for reviewing instructions, searching existing data sources, gathering and maintaining the data needed, and completing and reviewing the collection of information. Send comments regarding this burden estimate or any other aspect of this collection of information, including suggestions for reducing this burden, to Washington Headquarters Services, Directorate for Information Operations and Reports, 1215 Jefferson Davis Highway, Suite 1204, Arlington VA 22202-4302. Respondents should be aware that notwithstanding any other provision of law, no person shall be subject to a penalty for failing to comply with a collection of information if it does not display a currently valid OMB control number.

1. REPORT DATE DEC 1989	2. REPORT TYPE	3. DATES COVERED 00-00-1989 to 00-00-1989			
4. TITLE AND SUBTITLE Modification To Sea Data Wave Gages For Coastal Use		5a. CONTRACT NUMBER			
		5b. GRANT NUMBER			
		5c. PROGRAM ELEMENT NUMBER			
6. AUTHOR(S)		5d. PROJECT NUMBER			
		5e. TASK NUMBER			
		5f. WORK UNIT NUMBER			
7. PERFORMING ORGANIZATION NAME(S) AND ADDRESS(ES) U.S. Army Engineer Waterways Experiment Station, Coastal Engineering Research Center, Vicksburg, MS, 39180		8. PERFORMING ORGANIZATION REPORT NUMBER			
9. SPONSORING/MONITORING AGENCY NAME(S) AND ADDRESS(ES)		10. SPONSOR/MONITOR'S ACRONYM(S)			
		11. SPONSOR/MONITOR'S REPORT NUMBER(S)			
12. DISTRIBUTION/AVAILABILITY STATEMENT Approved for public release; distribution unlimited					
13. SUPPLEMENTARY NOTES					
14. ABSTRACT The Sea Data wave gage is used extensively by the Corps of Engineers to obtain wave measurements. It measures water pressure with a transducer and records the time series of pressure fluctuations on an internal cassette tape. When deploying internal recording gages, failure of the gage for any reason cannot be detected until after recovery. If failure occurs the costs of deploying and recovering the instrument may be wasted. Failure to obtain the required data may in turn have other adverse consequences.					
15. SUBJECT TERMS					
16. SECURITY CLASSIFICATION OF:			17. LIMITATION OF ABSTRACT	18. NUMBER OF PAGES	19a. NAME OF RESPONSIBLE PERSON
a. REPORT unclassified	b. ABSTRACT unclassified	c. THIS PAGE unclassified	Same as Report (SAR)	3	

and replaced by ambient water. In that case the tube can be plugged by microorganisms (some thrive in the oil/water mixture) or by sediment if the grain size is small (silts and mud) and the suspended concentration is high.

Blockages that occur in the tube are not visibly detectable without complete removal of the delicate, quartz crystal transducer, which is not part of routine maintenance. Even when removed, clogging of this tubing is not always evident, and partial blockage is practically undetectable, either from inspection or testing.

A gage is calibrated by recording its output to a sequence of known static pressures. A typical gage checkout involves running the gage on the bench and verifying that it accurately records atmospheric pressure for some interval. A pressure port can be partially plugged, or filled with a viscous material that transmits static pressure accurately. A gage with this condition can pass routine checks and be certified for use. When deployed and exposed to the pressure fluctuations caused by passing waves, it attenuates the dynamic signal. This dampening increases with wave frequency and changes over time. Lower frequencies, such as tides or long wind waves, will be recorded, while higher frequencies are filtered by some unknown amount. This is why partial clogging is seldom apparent, unless data from a nearby, working gage are available for comparison.

A flexible diaphragm can be fitted to the existing pressure port that will prevent the intrusion of ambient water and bio-fouling while allowing pressure to be transmitted to the transducer. It is designed as an attachment of the existing gage and does not require modification to the gage cover.

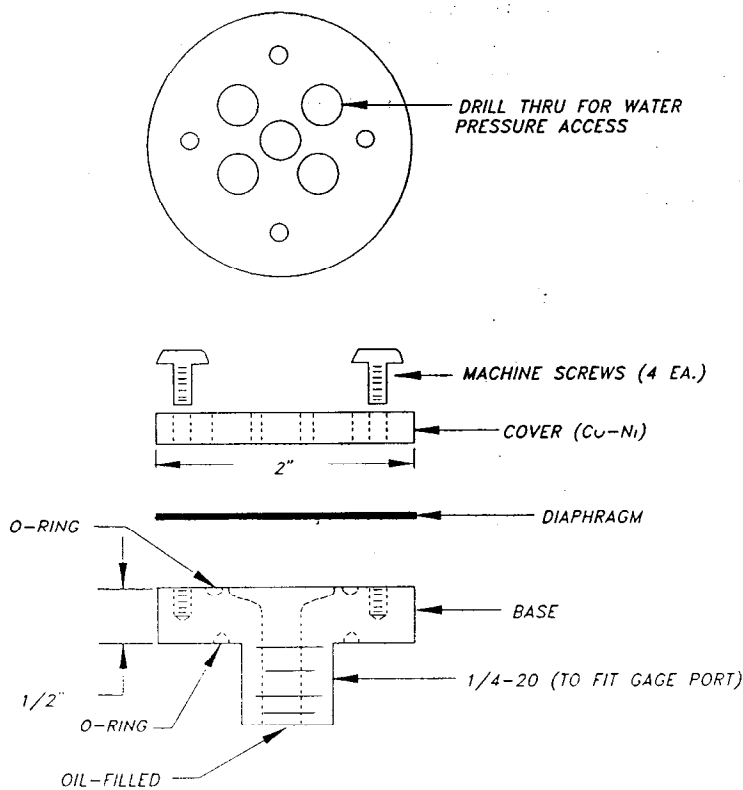

Figure 1

COSTS: The approximate cost to build and install the fitting is \$600.

DESIGN: A three-piece fitting can be constructed that will screw into the existing pressure port of the Sea Data 635 series gages (fig. 1). It consists of a base with a threaded male plug, a rubble diaphragm, and a cover attached by machine screws. An O-ring is installed between the diaphragm and the base to seal the oil behind the diaphragm from the external water. Holes in the cover allow water pressure to be transmitted through the diaphragm to the oil chamber. This prevents sediment or microorganisms from entering the oil path.

MATERIALS: The base is made from stainless steel to avoid galvanic potential with the aluminum gage cover. The diaphragm cover is made from a copper-nickel (90% Cu/Ni) alloy that is inherently anti-fouling without additional coatings. It is easily machined and commercially available in round stock. The diaphragm is a commercially available Nitril synthetic rubber compound, as is the O-ring. The cover is attached to the base with nylon machine screws to prevent electrical continuity between the Cu/Ni and the base or aluminum cover.

PROCEDURE: Some additional precautions are required in assembly to avoid entraining air behind the diaphragm or pre-loading the transducer. Even microscopic air bubbles dissolved in the oil can induce a hysteresis loss to the pressure response of the gage through the heat transfer associated with expanding and contracting a gas. The oil should be de-gassed in a vacuum chamber until out-gassing has ceased (up to twelve hours). The transducer, tube and base of the fitting are assembled to the case. The oil can then be gently transferred to the tube and the base of the fitting with a hypodermic syringe. Final assembly of the diaphragm on the base is done by sliding the diaphragm horizontally over the oil-filled base, then from monitoring the transducer output during assembly, and can be corrected by removing oil from under the diaphragm with the syringe and re-attaching the cover.

INFORMATION: For additional information, contact David McGehee, CEWES-CD-P (601) 634-4270.