

REPORT DOCUMENTATION PAGE

Form Approved
OMB No. 0704-0188

Public reporting burden for this collection of information is estimated to average 1 hour per response, including the time for reviewing instructions, searching existing data sources, gathering and maintaining the data needed, and completing and reviewing this collection of information. Send comments regarding this burden estimate or any other aspect of this collection of information, including suggestions for reducing this burden to Department of Defense, Washington Headquarters Services, Directorate for Information Operations and Reports (0704-0188), 1215 Jefferson Davis Highway, Suite 1204, Arlington, VA 22202-4302. Respondents should be aware that notwithstanding any other provision of law, no person shall be subject to any penalty for failing to comply with a collection of information if it does not display a currently valid OMB control number. **PLEASE DO NOT RETURN YOUR FORM TO THE ABOVE ADDRESS.**

1. REPORT DATE (DD-MM-YYYY) 20-07-2012		2. REPORT TYPE Conference Paper		3. DATES COVERED (From - To)	
4. TITLE AND SUBTITLE Phase-Change Thermal Energy Storage and Conversion: Development and Analysis for Solar Thermal Propulsion				5a. CONTRACT NUMBER	
				5b. GRANT NUMBER	
				5c. PROGRAM ELEMENT NUMBER	
6. AUTHOR(S) Gilpin, M.R.; Scharfe, D.B.; Young, M.P.				5d. PROJECT NUMBER	
				5f. WORK UNIT NUMBER 50260542	
7. PERFORMING ORGANIZATION NAME(S) AND ADDRESS(ES) Air Force Research Laboratory (AFMC) AFRL/RQRS 1 Ara Drive Edwards AFB CA 93524-7013				8. PERFORMING ORGANIZATION REPORT NUMBER	
9. SPONSORING / MONITORING AGENCY NAME(S) AND ADDRESS(ES) Air Force Research Laboratory (AFMC) AFRL/RQR 5 Pollux Drive Edwards AFB CA 93524-7048				10. SPONSOR/MONITOR'S ACRONYM(S)	
				11. SPONSOR/MONITOR'S NUMBER(S) AFRL-RQ-ED-TP-2012-248	
12. DISTRIBUTION / AVAILABILITY STATEMENT Approved for public release; distribution unlimited (PA #12601).					
13. SUPPLEMENTARY NOTES For presentation at the 48 th AIAA/ASME/SAE/ASEE Joint Propulsion Conference, Atlanta, GA, 29 July – 1 August 2012.					
14. ABSTRACT Solar thermal propulsion offers a unique combination of high thrust and high specific impulse that can provide competitive advantages relative to traditional satellite propulsion systems. Enhancing the functionality of this technology will require a robust thermal energy storage method that can be combined with thermophotovoltaic thermal-electric conversion. This combination creates a high performance dual mode power and propulsion system that can eliminate the traditional photovoltaic-battery combination on existing satellites. A thermal energy storage system based on the phase change of molten elemental materials is proposed as the enabling technology. Molten boron is identified as the optimal phase change material (PCM), but presents significant engineering challenges. Thus, molten silicon is proposed as a near term, moderate performance storage option. A systems level comparison against existing technologies shows that both materials present a performance benefit with current technological benchmarks, and with optimistic future assumptions, it appears that a more than 40 % ΔV improvement over chemical system is possible from boron based STP while maintaining high satellite maneuverability. An ongoing experimental effort is focused on producing a proof of concept thermal energy storage system. Materials testing has determined the stability of boron nitride in the presence of molten silicon in the short term, and solar furnace testing has resulted in silicon melting for the first time. Testing of the solar furnace using copper as a surrogate PCM has revealed experimental concerns with PCM heat transfer rates and has resulted in a design for a new full scale solar furnace. This furnace will operate at scales that are relevant to spacecraft development.					
15. SUBJECT TERMS					
16. SECURITY CLASSIFICATION OF:			17. LIMITATION OF ABSTRACT	18. NUMBER OF PAGES	19a. NAME OF RESPONSIBLE PERSON
a. REPORT	b. ABSTRACT	c. THIS PAGE			Marcus Young
Unclassified	Unclassified	Unclassified	SAR	12	19b. TELEPHONE NUMBER <i>(include area code)</i> N/A

Phase-Change Thermal Energy Storage and Conversion: Development and Analysis for Solar Thermal Propulsion

M.R. Gilpin*

University of Southern California, Los Angeles, CA 90089, United States

D.B. Scharfe†

ERC Incorporated, Edwards AFB, CA 93524, United States

M.P. Young‡

Air Force Research Laboratory, Edwards AFB, CA 93524, United States

Solar thermal propulsion offers a unique combination of high thrust and high specific impulse that can provide competitive advantages relative to traditional satellite propulsion systems. Enhancing the functionality of this technology will require a robust thermal energy storage method that can be combined with thermophotovoltaic thermal-electric conversion. This combination creates a high performance dual mode power and propulsion system that can eliminate the traditional photovoltaic-battery combination on existing satellites. A thermal energy storage system based on the phase change of molten elemental materials is proposed as the enabling technology. Molten boron is identified as the optimal phase change material (PCM), but presents significant engineering challenges. Thus, molten silicon is proposed as a near term, moderate performance storage option. A systems level comparison against existing technologies shows that both materials present a performance benefit with current technological benchmarks, and with optimistic future assumptions, it appears that a more than 40 % ΔV improvement over chemical system is possible from boron based STP while maintaining high satellite maneuverability. An ongoing experimental effort is focused on producing a proof of concept thermal energy storage system. Materials testing has determined the stability of boron nitride in the presence of molten silicon in the short term, and solar furnace testing has resulted in silicon melting for the first time. Testing of the solar furnace using copper as a surrogate PCM has revealed experimental concerns with PCM heat transfer rates and has resulted in a design for a new full scale solar furnace. This furnace will operate at scales that are relevant to spacecraft development.

Nomenclature

ΔV	A change in velocity, V	ϵ	Emissivity
I_{sp}	Specific impulse	A	Surface Area
$P_{Required}$	Solar power input required	σ_{SB}	Stefan-Boltzmann constant
$\eta_{Shielding}$	Shielding Efficiency	T	Temperature
m	Graphite mass	q	Heat transfer rate
C_p	Specific heat	k_{th}	Thermal Conductivity

*Ph.D. Student, USC Dept. of Mech. and Aerospace Engineering, 854 W 36th Pl, L.A., CA 90089, AIAA Member

†Staff Scientist, Advanced Propulsion, AFRL/RQRS, 10 E. Saturn Blvd, Edwards AFB, CA 93524, AIAA Member

‡Program Manager, Advanced Propulsion Concepts, AFRL/RQRS, 10 E. Saturn Blvd, Edwards AFB, CA 93524, AIAA Member

I. Introduction

Solar thermal propulsion (STP) offers a unique combination of high thrust and high specific impulse (I_{sp}), which can provide significant advantages over chemical and electric propulsion systems in certain mission scenarios. In particular, microsattellites show strong potential performance when using STP. Traditionally, however, STP has been viewed as somewhat limited due to the solar illumination requirement for propulsion. Additionally, unlike chemical or electric propulsion which can draw power from the existing subsystem on a spacecraft (i.e. photovoltaic cells batteries), a solar thermal propulsion system requires a separate, dedicated system for thermal energy.

It is suggested here that by combining a robust thermal energy storage solution with high performance thermal-electric conversion, the thermal energy subsystem on the spacecraft could satisfy both propulsive and electrical requirements. By using the latent heat of molten elemental materials, a high temperature and high density thermal energy storage solution can be derived that overcomes the issues commonly associated with STP.

The ongoing research effort presented here is focused on determining the feasibility of a bimodal solar thermal propulsion system based on high performance energy storage. While previous solar thermal efforts have included a means of thermal energy storage, the key difference proposed here is the optimization of such a system utilizing a phase change material. This will allow for a greater energy storage density and relatively constant temperature operation which yields more predictable performance. This paper discusses a systems level comparison of the proposed technology with conventional systems and the current state of the experimental effort to develop a proof of concept thermal energy storage system.

II. Augmented Solar Thermal Propulsion for Microsatellites

It has been proposed, that a solar thermal propulsion system combining high performance thermal energy storage and thermal electric conversion can overcome the typical drawbacks of an STP system and provide an enabling technology for high performance microsattellites.^{1,2} Such a system, if well designed, could dramatically expand the microsattellite operational envelope by providing 1.5-2 km/s total ΔV . While, large ΔV missions are possible with electric propulsion options, the relative high thrust produced by an STP system reduces the total maneuver time from years to days.

To favorably compete with existing technology on a 100 kg microsattellite, a bimodal STP system must provide 100 W of continuous electrical power and have continuously available propulsion on the order of 1 N with an I_{sp} of 300-400 s . This level of performance can be achieved with an ammonia based solar thermal rocket which has practical advantages over a system based on cryogenic H_2 propellant. To drive this thermal rocket, a solar concentration mechanism with a concentration ratio of 10,000:1 and fiber optic coupling to the storage device is required and appears to be feasible based upon the current state of technological development.²

The enabling technology for a bimodal STP system is high performance thermal energy storage. Energy must be stored at a high density (>750 kJ/kg) and delivered at high temperatures to provide adequate performance from the ammonia rocket. Previous solar thermal efforts have included sensible heat energy storage in their design by using high temperature materials such as graphite.^{3,4} High energy densities can be achieved in this manner, however, the large ΔT required (ΔT of 600 K for 1.5 MJ/kg in graphite) can result in reduced thruster performance, increased thermal stress on the spacecraft, and lower thermal-electric energy conversion efficiency.

Augmenting a STP system with latent heat thermal energy storage reduces the complications associated with a large operational ΔT and offers similar or greater energy densities when compared to a sensible heat system. Current state of the art phase change materials (PCMs), designed for terrestrial systems, are inadequate for spacecraft applications due to low temperature operation, low energy storage density, and degradation from repeated cycling. Thus, a new class of PCMs must be developed that have a properly matched melting temperature and a sufficiently high latent heat capacity. A survey of candidate PCMs, some of which are given in Table 1, indicate that molten elemental materials may meet these requirements.

Specifically, silicon and boron have been selected as the target energy storage materials. Boron is identified as the ideal far-term storage material due to an extremely high heat of fusion and a melting temperature

Table 1. Potential high temperature phase change materials.

Material	T_{melt} [K]	ΔH_{fus}^o [kJ/kg]	k_{th} [W/mK]
MgF ₂	1536	940	-
Beryllium	1560	1312	200
Silicon	1687	1785	149
Nickel	1720	298	90.9
Scandium	1814	313	15.8
Chromium	2180	403	93.9
Vanadium	2183	422	30.7
Boron	2570	4600	27.4
Ruthenium	2607	381	117
Niobium	2750	323	53.7
Molybdenum	2896	390	138

close to the optimal performance point for an ammonia based STP rocket.⁵ It must be noted that limited research has gone into handling boron in the molten state. Therefore, silicon, is also targeted as a near term storage option providing storage capacities on par with sensible heat systems and a storage temperature that will provide moderate thrust performance.

If used as the primary energy storage mechanism onboard a spacecraft, a boron or silicon based system, must supply both propulsive and electrical power. A comparison of state of the art thermal-electric conversion technologies indicates that thermophotovoltaic (TPV) conversion is the best option for an augmented STP system based on a relatively high conversion efficiency and ability to operate at high temperatures.⁶ The stable, high temperature energy delivery of the proposed latent heat system is well suited to thermophotovoltaic operation and the high temperatures of a boron based system has peak emission wavelengths near the cutoff for existing InGaAs photovoltaic cells.

With the addition of TPV electrical energy conversion, a STP system utilizing high temperature phase change energy storage becomes a true bimodal system and the photovoltaics and batteries typical of satellite design can be eliminated. A dedicated propulsion and power unit based entirely on thermal energy is the sole energy source on board a spacecraft which simplifies spacecraft design and allows for microsatellite scalability.

III. System Comparison

In order to directly compare the proposed bimodal STP system with existing technologies, theoretical systems were sized using a variety of parameters (i.e.: propellant budget, desired ΔV , phase change material) and compared to other potential microsatellite propulsion and power systems.

Targeting the high-performance microsatellite category, a sample bimodal STP system was sized for a 100 kg microsatellite with a 1500 m/s ΔV capability. The base system was configured with silicon as the PCM and an energy storage capacity capable of simultaneously providing 100 W of full-time converted electrical energy and 100 W of average thermal power output for the propulsion system in a low-Earth orbit (LEO). The sizing of the bimodal STP system, including all power and propulsion components, was based upon previous research and conservative values for readily-achievable technology.⁶⁻¹⁰ During this mass-budgeting process, parameters of interest included the weight of the solar concentration system (fiber optics, primary concentrator and support structure), thermal energy storage weight (PCM, container, and insulation), power system weight (TPV, radiators, electronics), and the weight of an ammonia STP propulsion system (tankage, flow system, engine, and propellant weight). Calculations assumed that thruster firing would only occur for 5% of the time at 20-times the average power (i.e. near apogee and perigee of maneuver orbits for efficiency). In this way, utilizing the silicon PCM and essentially “proven” system components documented in the literature, the system was sized to provide 1500 m/s ΔV in under 23 days with a combined propulsion and power mass budget of just over 58 kg.

Holding this mass fraction constant (i.e. assuming systems for comparison must have an identical mass

budget for the payload and other non-propulsion and power systems on a 100 kg microsatellite), system budgets and capabilities were calculated for competing technologies published in the literature, including a 1 N Hydrazine thruster, a 20 N hydrazine thruster,^{11,12} a standard (non-bimodal) STP system, and a 100 W Hall Effect Thruster. It was assumed that all of these technologies required a standard electrical power system, including photovoltaic panels and batteries suitable to meet the same 100 W power draw while propulsion systems were active. The results of these calculations, along with the results for the silicon bimodal system, are presented in Figure 1. As with the bimodal system sizing, the relative weights of power systems, tankage, and thrusters were determined primarily through previously established sizing metrics.^{13,14} NASA’s year-2020 target for photovoltaic power density¹⁵ was used to size the traditional power systems, saving mass relative to current technologies available. Additionally, it should be noted that for chemical and electrical propulsion cases, it was assumed that the thrusters fired continuously to deliver the desired ΔV ; this would result in additional orbit-change inefficiency, and a smaller orbit change relative to the ΔV imparted. Alternatively, if the same 5% firing time was enforced on these thrusters as the proposed STP systems, the maneuver times would have been increased by a factor of 20, pushing the comparative system response significantly higher.

In spite of a favorable presentation of the competing technologies, Figure 1 shows the unique position occupied by the STP systems. The standard STP option already occupies a performance gap between chemical and EP systems, allowing a higher ΔV than the chemical systems without the years-long maneuver time of the Hall Thruster. When the silicon thermal energy storage system is added to provide propulsive power during eclipse and to replace the traditional power system, performance jumps considerably — the response time drops slightly, and the ΔV shows a 10% advantage over chemical systems.

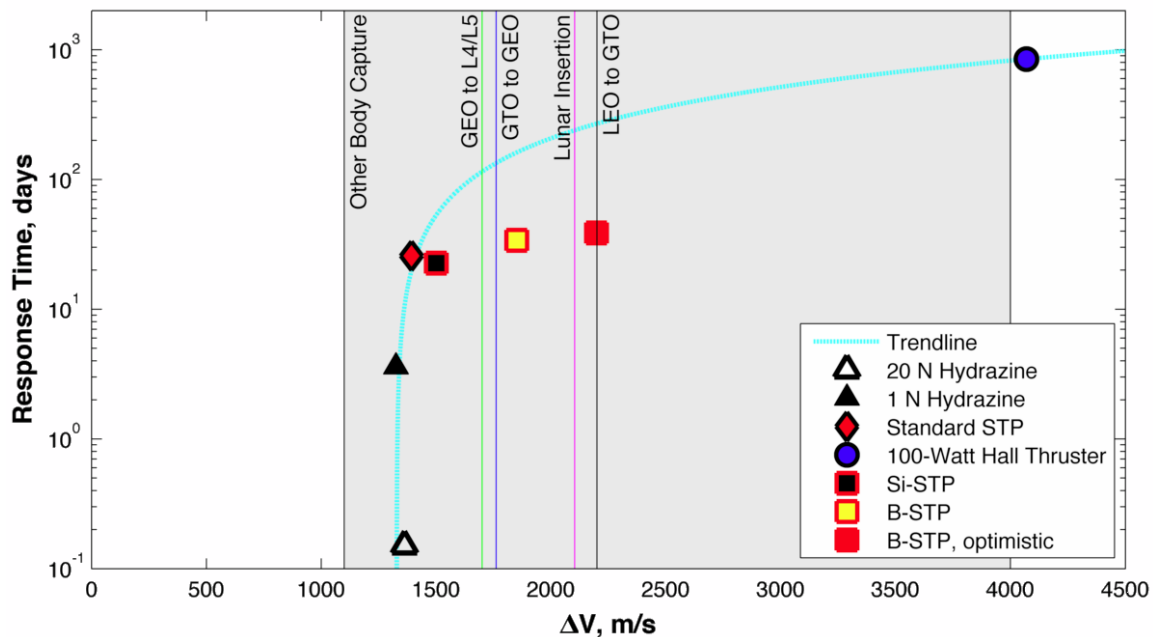

Figure 1. Comparison of calculated system performance for the proposed bimodal STP technology and various competing systems. Solid lines indicate specific mission requirements.

Replacing the silicon PCM with boron reduces the amount of PCM required, allowing for slightly more propellant within the power-and-propulsion mass budget. Simultaneously, the boron based system operates at a higher melting temperature, providing higher *Isp* propulsion (though slightly lowering the thrust and increasing the response time, consistent with the assumption that average propulsive power draw remains constant). With this change, and still sizing other power and propulsion components via published readily-achievable technology, the response time increases slightly to 34 days, but the total available ΔV increases to over 1850 m/s; the boron system has a 35% ΔV advantage over the chemical rockets while still providing a highly-responsive architecture.

Making more optimistic estimates for system components (i.e.: increasing the TPV plus radiator power efficiency from currently-available 15 W/kg to 30 W/kg, and cutting fiber optic mass from 5 to 2.5 kg) could allow additional propellant to be utilized in future systems, allowing an advanced bimodal boron-STP system with a response time of under 40 days and a total ΔV approaching 2200 m/s. At this level, the STP system can provide a ΔV that cannot be reasonably considered using chemical systems, while remaining several orders of magnitude more responsive than an EP system.

As microsattellites can be delivered into orbit at relatively low cost by piggy-backing on the launch vehicles of larger satellites, the ability to rapidly reposition into a drastically different orbit (i.e. the desired orbit for the microsattelite mission) can significantly enhance the utility and frequency of microsattelite launches. Additionally, note the sample maneuvers marked via the vertical lines and shaded areas on the Figure 1.⁸ Development of the proposed bimodal STP technology could provide for a microsattelite platform that can not only piggy-back on the launch of a conventional satellite and reposition itself accordingly, but could also result in microsattelites capable of transferring into Lagrange Point orbits or even inserting into lunar or asteroid orbits.

IV. Experimental Developments

An experimental effort is underway at the University of Southern California to provide physical insight into the problems associated with high temperature thermal energy storage. The goals of this research effort are to construct a research grade solar furnace and create a proof of concept energy storage system based around molten elemental PCMs. In doing this, the practical problems of latent heat thermal energy storage can be uncovered and the feasibility of a bimodal STP system can be determined.

IV.A. Materials Testing

Utilizing latent heat for energy storage requires a container that is capable of holding a PCM in the liquid state with minimal contamination and long term stability. Molten boron and molten silicon are both highly reactive and a literature search has identified boron nitride (BN) ceramic as the most promising container material. This ceramic has a low reactivity with boron and it appears that the reaction between BN and silicon is self limiting.^{1,16}

To investigate the stability of these materials, test articles were manufactured and placed in a high temperature tube furnace. These crucibles, which are diagramed in Fig. 2, were machined from industrial graphite with an inner PCM cavity that could be lined 1/16 *in* thick BN. The test articles were filled with 99+% pure, 325 mesh silicon powder and sealed with a graphite plug.

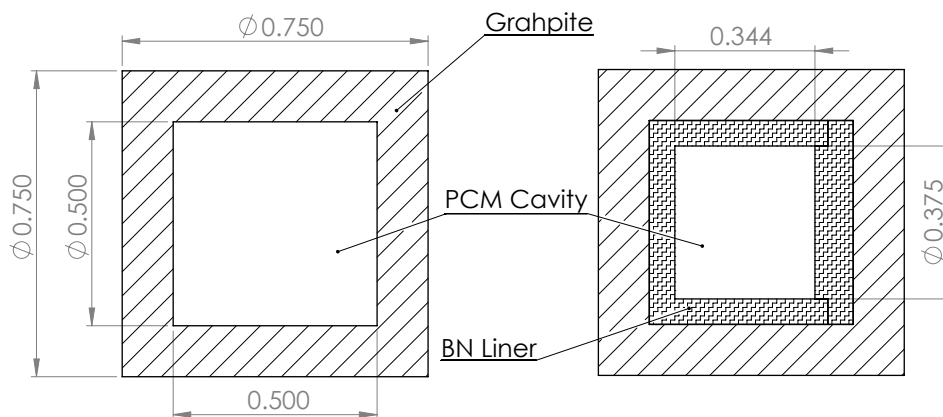

Figure 2. Cut-away diagram of tube furnace test articles with and without a BN liner.

During testing, the sealed crucibles were brought up to 1550 °C and held for approximately 12 hours at

temperature in an argon environment. After cooling, the exterior of the crucibles showed no change and the test articles were cut in half to inspect for damage. Both bare graphite crucibles and those with a BN liner indicated that silicon had flowed, consolidated, and pulled away from the container walls. It can be seen in Fig. 3, that the silicon powder consolidated into multiple small beads as opposed to a single silicon mass. A potential cause for this behavior is contamination of the silicon powder itself. Due to the small particle size (44 microns and smaller), the thin SiO_2 coating that forms when the silicon powder is exposed to air becomes significant.

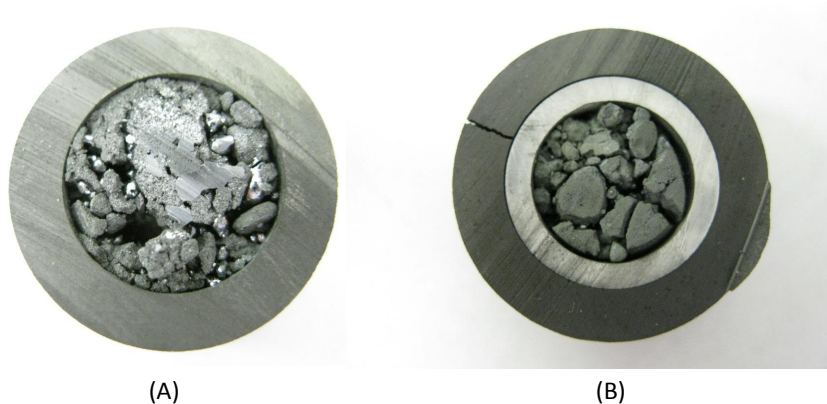

Figure 3. Cut away photographs of tube furnace test articles after 12 hours at 1550 °C. (A) Bare graphite crucible (B) Crucible with a BN liner. Note that the crack in the graphite outer shell was present prior to testing.

In both tests, there appears to be no damage to the crucibles themselves and no wetting of the interior walls. This was the expected behavior for the boron nitride lined crucible, however, significant wetting was expected in the bare graphite case. The lack of physical damage indicates that under short term use, BN is a viable container material. Additional long term testing is still required and will be performed with large pieces of crystalline silicon to mitigate the effects of oxygen contamination.

IV.B. Solar Furnace Testing

Using concentrated solar power as the basis for experimentation ensures strong correlation between experimental data and the final spacecraft system. The USC solar furnace currently has a two stage design using a 5.75 m^2 heliostat and temporary 1 m^2 acrylic Fresnel lens. While providing relatively low power, this arrangement has facilitated the technological development necessary for the proper use of a full scale furnace.

IV.B.1. Solar Furnace Diagnostics

Calibrated CCD cameras have been used to produce flux maps of the solar image from the USC furnace. By placing the output of the Fresnel lens on a Lambertian surface and capturing the image at a set distance with pre-determined camera parameters, a highly detailed flux profile is derived. The total power delivery into the test section is determined by integrating over the flux profiles. A sample flux profile is given in Fig. 4.

Due to aberrations in the image produced, and the relative quality of the Fresnel lens, the overall transmission efficiency is low at approximately 25 %. For optimal testing conditions, the CCD flux mapping diagnostics are used to determine the overall power delivery at various distances along the optical axis. To compensate for imperfections in the lens, flux profiles are compared and the best location for the test section is determined. Currently, the Fresnel lens based furnace has a peak concentration ratio of approximately 2500:1 and is able to deliver 200-240 W depending on current solar conditions. These measurements have also been taken and verified through the use of a commercially available thermopile based laser power meter.

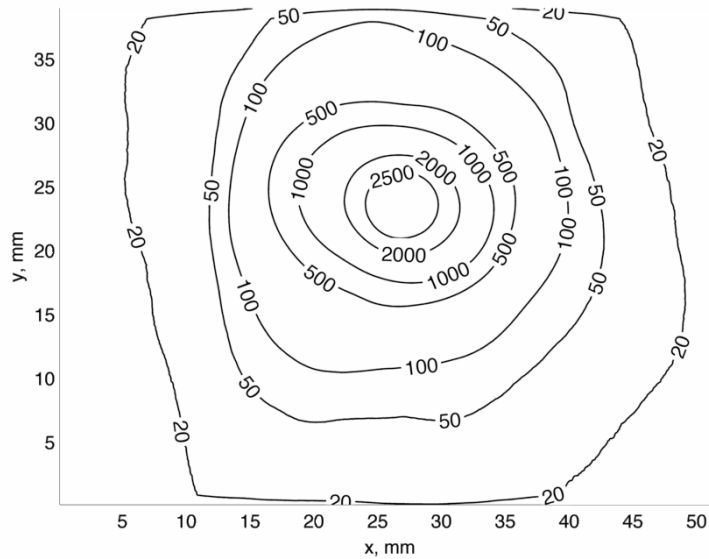

Figure 4. Solar flux profile measured 1.2 inches forward of the visual focus with a peak concentration ratio of 2500:1. The units on the indicated contours are the number of suns, which is equivalent to the concentration ratio.

IV.B.2. Radiation Shielding and Crucible

Using information from the the solar furnace characterization, a new radiation shield has been built based upon a design published by Steinfeld and Fletcher.¹⁷ The radiation shield consists of two 3 *in* diameter aluminum hemispheres with highly polished inner surfaces mounted in an aluminum support structure. The front hemisphere has been cut to allow the input of solar radiation and the entrance aperture has a 40° rim angle, as seen from the center of the shielding cavity. Bullet shaped graphite crucibles machined from 0.75 *in* long, 0.75 *in* diameter graphite rod, are mounted on a tantalum sheathed, Type C thermocouple probe and positioned in the center of the spherical cavity. These graphite crucibles are produced in the same manner as the tube furnace test sections and have an inner cavity to contain the PCM of interest. For furnace and shielding characterization testing, solid graphite crucibles are used to simplify analysis. A basic outline of the new test assembly can be seen in Fig. 5.

The model proposed in Steinfeld and Fletcher suggests that this configuration should yield an approximately 70% reduction in radiation loss and experimental testing shows an approximate reduction of 50-55% based upon the analysis of cooling curves. The discrepancy is due to the level of polish on the aluminum spheres and imprecise machining and positioning of experimental components compared with the theoretical inputs.

If the shielding efficiency is defined as the percent reduction in radiation losses, the power input required to reach a desired experimental temperature, in a radiation dominated system, effectively varies by a factor of

$$P_{required} \approx \left(\frac{1}{1 - \eta_{Shielding}} \right)^{\frac{1}{4}} \quad (1)$$

At low to mid efficiencies the effect of increasing shielding has a quasi-linear effect. At roughly 70% efficiency, however, further shielding refinement begins to dramatically effect the maximum achievable temperature. To take advantage of this and further increase experimental temperatures, testing was also performed with a cast ZrO₂ sheath around the existing graphite crucible. This ceramic was covered by a highly polished stainless steel covering that, when paired with the primary aluminum shield, produced a rudimentary version

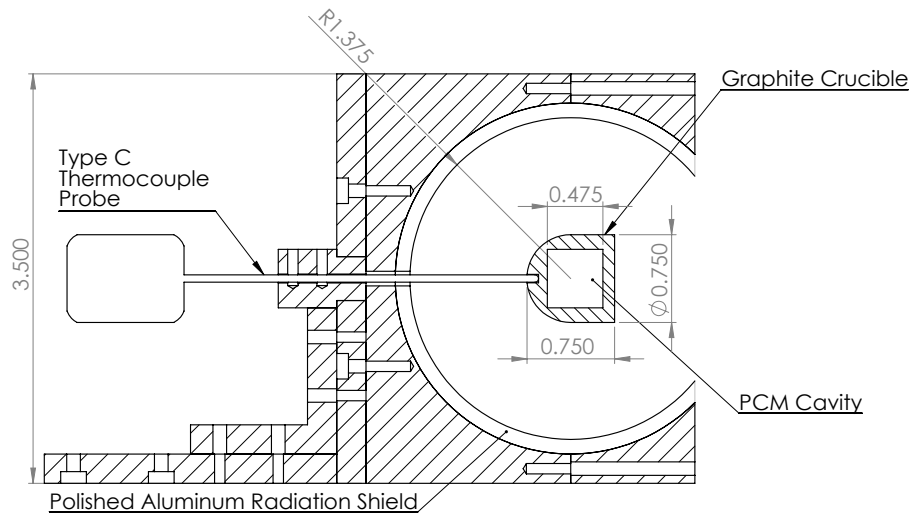

Figure 5. 2D schematic of the test section and support structure including the spherical radiation shielding cavity, thermocouple sting mount, and graphite crucible. Dimensions shown are in inches.

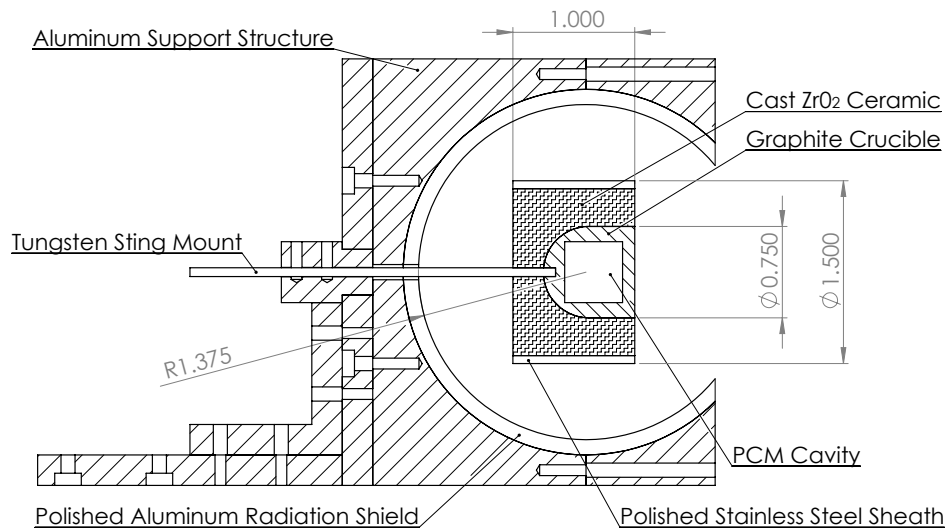

Figure 6. 2D schematic of the test section and support structure with additional cast ceramic and stainless steel insulation. Dimensions are shown in inches.

of the low emissivity vacuum gap that will be essential to future designs. A diagram of the system with ceramic insulation is given in Fig. 6.

IV.C. Testing Results and Analysis

Current testing with the Fresnel lens based system is yielding lower than expected peak temperatures because of inefficiencies in the furnace design. Testing with bare crucibles has yielded peak temperature below those required for molten silicon testing and testing with ceramic insulated crucibles has produced only localized melting that is insufficient for analysis. However, testing using copper as a sample PCM has indicated necessary enhancements to both the solar furnace and analysis techniques.

Copper has a relatively low heat of fusion and the lower operational temperatures result in similarly reduced radiative loss. Thus, to the first order, similar system behavior to molten silicon is expected. Temperature diagnostics have been performed with both the Type C thermocouple sting mount, as well as an infrared, emissivity sensing pyrometer measuring the front surface of the crucible during cooling.

Assuming negligible conduction losses through the sting mount, a cooling curve can be estimated for the graphite crucible using the following equation:

$$mC_p \frac{dT_{Crucible}}{dt} = -\epsilon A \sigma_{SB} (T_{Crucible}^4 - T_{Surr}^4) \times (1 - \eta_{Shielding}) + q_{Cond} + q_{Rad}. \quad (2)$$

Equation 2 describes the time rate of change of the crucible temperature with the left hand side representing the loss of sensible heat and the right hand side representing heat loss by radiation to the surroundings, heat input into the graphite from the PCM due to conduction and heat input from the PCM due to radiation. Both the PCM and the graphite are assumed to have a uniform temperature (infinite k_{th}) and it is assumed that the PCM is isothermal during the phase transition. Based on this, the conduction can be modeled with a known PCM-graphite contact area and an estimated thermal contact resistance. The radiation transfer between the PCM and the graphite is modeled as a two surface cavity with known emissivities. This arrangement can be solved numerically to produce a temperature curve for both a phase change and a non phase change case.

Figure 7A shows that additional heat transfer from the PCM to the graphite during the phase change, results in a gradual reduction in cooling. Once phase change is complete, the crucible resumes the previous cooling curve. This gradual slow down is a function of the temperature difference between the graphite and PCM as well as the PCM mass fraction. This model indicates that an isothermal heat release from the storage system will require a high PCM mass relative to the container.

Cooling curves were experimentally recorded for a 5.8 g graphite crucible containing 5.4 g of copper after heating to approximately 1250 °C. A sample experimental curve is shown in Figure 7B and compared with the 1D model. The experimental cooling curve displays the expected behavior with a gradual reduction in cooling during the phase transition period. However, this process is more gradual than the 1D model suggests. If the heat transfer between the PCM and the graphite is significantly reduced, as seen in Figure 7C, the simplified model can be made to follow the experimental data.

IV.D. Discussion and Future Work

Based on recent testing, it is apparent that the 1D model currently being used to predict behavior is insufficient to describe the interaction of the PCM with the container material. While qualitatively correct, quantitative results will have to remove the assumptions of instant phase transition and isothermal materials to understand the relatively low heat transfer rates seen in the experimental data. Additionally, the low heat transfer rates seen experimentally, and the "pull away" effect seen in tube furnace testing, necessitate a means of heat spreading in the final system design for effective heat draw from the PCM. Achieving the desired isothermal heat release from the storage mechanism will also require a PCM mass that is far greater than that of the container so the phase change process is dominant.

Currently experimental scale is limited in size due to the power density of the Fresnel lens based solar furnace and the fact that radiation losses scale with the crucible diameter. The ceramic insulation method

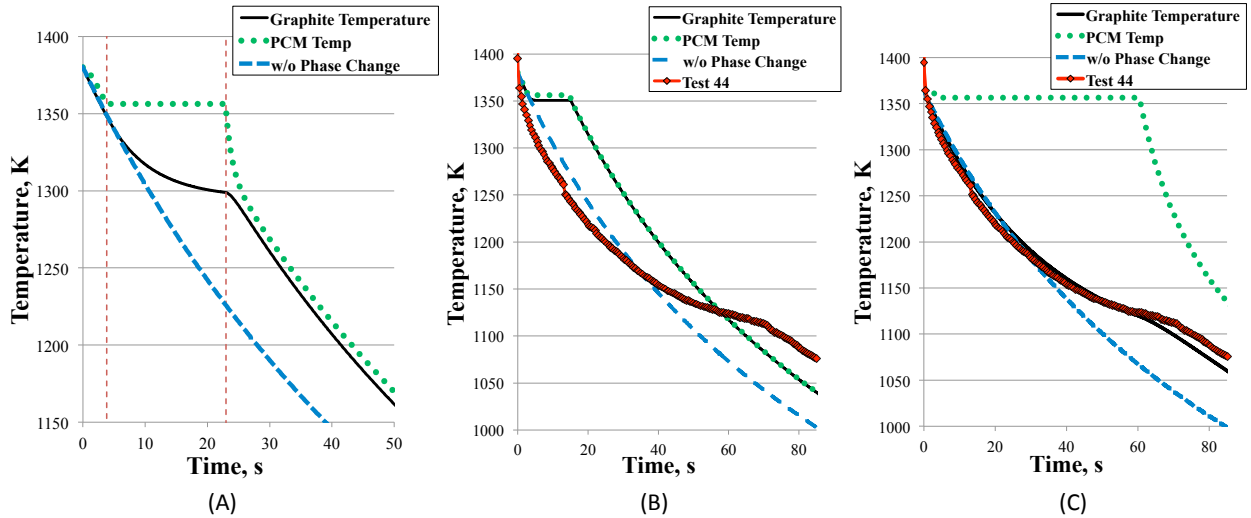

Figure 7. (A) Sample temperature profiles derived from Eq. 2 to illustrate the reduction in graphite cooling during the phase-change process (bounded by the dashed red lines), (B) Experimental cooling curve plotted against results from the 1D model indicating a slower real world response, (C) The same experimental data as (B) plotted against a 1D model with greatly reduced heat transfer rates between the PCM and graphite crucible.

shown in Fig. 6 has produced the first examples of molten silicon, however, the power levels are still not high enough to produce a bulk sample.

A new solar concentrator has been configured and is currently under construction for future high power testing. The new concentrator is a 4 x 4 array of 1500 square inch convex mirrors with a common radius of curvature of 124 in. Ray tracing analysis shows that despite spherical aberrations, a 400-600 % improvement in power delivery is expected over the current system depending on the desired spot size. Figure 8 shows the expected performance of the new solar furnace with analysis indicating that silicon testing can occur at scales relevant to a spacecraft system and small scale molten boron testing is a possibility.

V. Conclusions

A systems level comparison has shown that a bimodal solar thermal system, with high performance thermal energy storage, can eliminate the complications commonly associated with traditional STP systems and provide a strong combination of response time and ΔV capability. Molten boron based thermal energy storage, when combined with ammonia propellant and thermophotovoltaics, has the potential to yield a truly high performance, bi-modal propulsion and power system. However, a significant effort will be required to integrate molten boron into a systems design due to materials considerations at the operating temperature. Assuming that these challenges can be met, a bi-modal system would allow mission designers to increase the total ΔV of a satellite while sacrificing relatively little maneuverability when compared with electric propulsion options. In the near term, a STP system based around silicon as a phase change material holds promise as both a proof of concept for a PCM based system and as a moderate performance option.

The current experimental effort to develop a proof of concept system has begun testing material compatibility with molten silicon and boron nitride appears to be a stable container in the short term. Molten silicon has also been created for the first time using the USC solar furnace facility, albeit at scales too small to be of research interest. By using knowledge gathered from surrogate PCM testing and solar furnace characterization, a full scale solar furnace has been configured to test a molten silicon based system and potential technological pitfalls have been determined. After construction of a high power solar furnace is complete, research will focus on developing a multi-dimensional model for phase change material interaction with a container and enhancing insulation capability.

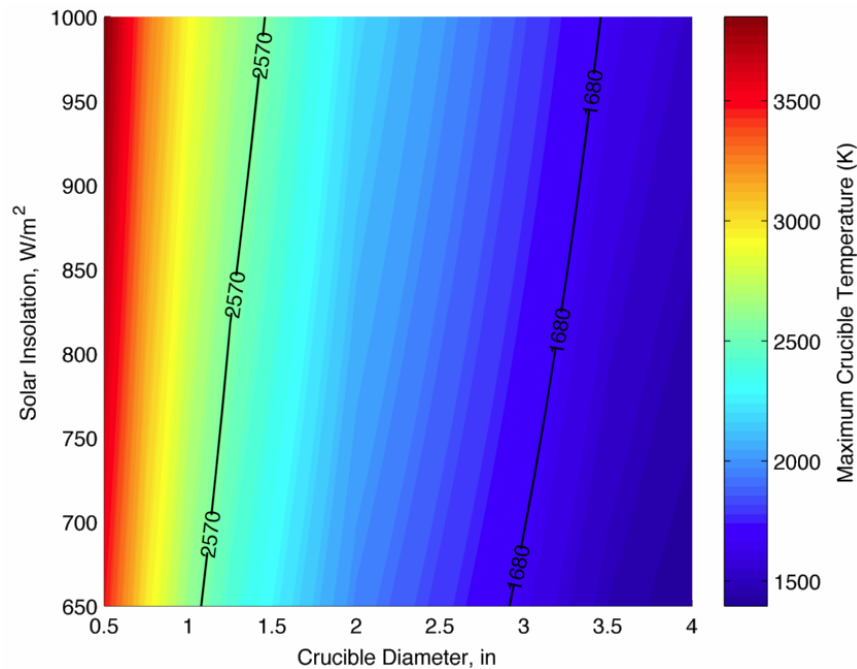

Figure 8. Color map showing expected solar furnace performance with a shielding efficiency of 80%. Crucibles are assumed to be cylindrical graphite sections with a length equal to the diameter. To determine power input, ray tracing analysis assumes a desired spot size equal to the crucible diameter. Contours are shown at the melting points of boron and silicon.

Acknowledgments

This work was funded by the In-Space Propulsion Branch at the United States Air Force Research Laboratory, Aerospace Systems Directorate. The authors would also like to Greg Yandek and Dave Lipke at the AFRL for their assistance in tube furnace testing.

References

- ¹Gilpin, M., Scharfe, D., Young, M., and Pancotti, A., "Molten Boron Phase-Change Thermal Energy Storage: Containment and Applicability to Microsatellites," *42nd AIAA Thermophysics Conference*, No. AIAA-2011-3637, American Institute of Aeronautics and Astronautics, 2011.
- ²Scharfe, D. B., Young, M. P., Gilpin, M. R., and Rexius, T., "Augmentation of Solar Thermal Propulsion Systems Via Phase Change Thermal Energy Storage and Thermal Electric Conversion," *AAAF-ESA-CNES Space Propulsion Conference*, Bordeaux, France, May 2012.
- ³Carroll, J., "Solar Orbit Transfer Vehicle," *AIAA Space Conference*, No. AIAA-2000-5110, American Institute of Aeronautics and Astronautics, 2000.
- ⁴Kennedy, F. and Jacox, M., "The Integrated Solar Upper Stage (ISUS) Program," *AIAA 1995 Space Programs and Technologies Conference*, American Institute of Aeronautics and Astronautics, Huntsville, AL, September 1995.
- ⁵Colonna, G., Capitta, G., Capitelli, M., Wysong, I., and Kennedy, F., "Model for Ammonia Solar Thermal Thruster," *Journal of Thermophysics and Heat Transfer*, Vol. 20, No. 4, October-December 2006.
- ⁶Gilpin, M., Scharfe, D., Young, M., and Pancotti, A., "Molten Boron Phase-Change Thermal Energy Storage to Augment Solar Thermal Propulsion Systems," *47th AIAA/ASME/SAE/ASEE Joint Propulsion Conference*, No. AIAA-2011-5986, American Institute of Aeronautics and Astronautics, 2011.
- ⁷Scharfe, D. and Ketsdever, A., "A Review of High Thrust, High Delta-V Options for Microsatellites Missions," *45th AIAA/ASME/SAE/ASEE Joint Propulsion Conference*, No. AIAA-2009-4824, American Institute of Aeronautics and Astronautics, August 2009.
- ⁸Kennedy, F. and Palmer, P. L., "Preliminary Design of Micro-Scale Solar Thermal Propulsion System," *38th AIAA/ASME/SAE/ASEE Joint Propulsion Conference*, No. AIAA-2002-3928, American Institute of Aeronautics and Astronautics, July 2002.
- ⁹Nakamura, T., Sullivan, D., McClanahan, A., Shoji, J., Partch, R., and Quinn, S., "Solar Thermal Propulsion for Small

Spacecraft - Engineering System Development and Evaluation-," *41st AIAA/ASME/SAE/ASEE Joint Propulsion Conference*, No. AIAA-2005-3923, American Institute of Aeronautics and Astronautics, 2005.

¹⁰Mueller, J., "Thruster Options for Microspacecraft: A Review and Evaluation of Existing Hardware and Emerging Technologies," Vol. AIAA 97-3058, 1997.

¹¹Astrium, E., 1N Hydrazine Thruster, Technical Specifications: <http://cs.astrium.eads.net>.

¹²Astrium, E., 20 N Hydrazine Thruster, Technical Specifications: <http://cs.astrium.eads.net>.

¹³Brown, C., *Spacecraft Propulsion*, AIAA, 1996.

¹⁴Larson, W. and Wertz, J., editors, *Space Mission Engineering: The New SMAD*, Microcosm Press, 1st ed., 2011.

¹⁵"NASA Technology Roadmaps: Propulsion and Power Workshop," Tech. rep., Aeronautics and Space Engineering Board, National Research Council, March 2012.

¹⁶Drevet, B., Voytovych, R., Israel, R., and Eustathopoulos, N., "Wetting and Adhesion of Si on Si₃N₄ and BN substrates," *Journal of the European Ceramic Society*, Vol. 29, February 2009, pp. 2363–2367.

¹⁷Steinfeld, A. and Fletcher, E. A., "A Spherical Receiver-Reactor with Specularly Reflecting Inner Surfaces for High-Temperature Solar Furnace Applications," *Proceedings of the Ninth International Heat Transfer Conference*, Jerusalem, Israel, 1990, pp. 127–132.