



**NAVAL  
POSTGRADUATE  
SCHOOL**

**MONTEREY, CALIFORNIA**

**CAPSTONE PROJECT REPORT**

**HAWAII ALGAL BIOFUEL**

by

Cohort 311-113A, Team HNAABS

March 2013

Capstone Advisor:

David H Olwell

Co-Advisor:

Joseph W Sweeney III

**Approved for public release; distribution is unlimited**

THIS PAGE INTENTIONALLY LEFT BLANK

<b>REPORT DOCUMENTATION PAGE</b>			<i>Form Approved OMB No. 0704-0188</i>	
Public reporting burden for this collection of information is estimated to average 1 hour per response, including the time for reviewing instruction, searching existing data sources, gathering and maintaining the data needed, and completing and reviewing the collection of information. Send comments regarding this burden estimate or any other aspect of this collection of information, including suggestions for reducing this burden, to Washington headquarters Services, Directorate for Information Operations and Reports, 1215 Jefferson Davis Highway, Suite 1204, Arlington, VA22202-4302, and to the Office of Management and Budget, Paperwork Reduction Project (0704-0188) WashingtonDC20503.				
<b>1. AGENCY USE ONLY (Leave blank)</b>		<b>2. REPORT DATE</b> March 2013	<b>3. REPORT TYPE AND DATES COVERED</b> Capstone Project Report	
<b>4. TITLE AND SUBTITLE</b> HAWAII ALGAL BIOFUEL			<b>5. FUNDING NUMBERS</b>	
<b>6. AUTHOR(S)</b> Cohort 311-113A, Team HNAABS				
<b>7. PERFORMING ORGANIZATION NAME(S) AND ADDRESS(ES)</b> Naval Postgraduate School Monterey, CA93943-5000			<b>8. PERFORMING ORGANIZATION REPORT NUMBER</b>	
<b>9. SPONSORING /MONITORING AGENCY NAME(S) AND ADDRESS(ES)</b> N/A			<b>10. SPONSORING/MONITORING AGENCY REPORT NUMBER</b>	
<b>11. SUPPLEMENTARY NOTES</b> The views expressed in this thesis are those of the author and do not reflect the official policy or position of the Department of Defense or the U.S. Government IRB Protocol number ___N/A___.				
<b>12a. DISTRIBUTION / AVAILABILITY STATEMENT</b> Approved for public release; distribution is unlimited			<b>12b. DISTRIBUTION CODE</b> A	
<b>13. ABSTRACT (maximum words) 200words</b> This report investigates the feasibility and affordability of producing algae-derived biofuel in Hawaii for military aviation. The authors evaluated methods for cultivation of algae, investigated the processes necessary to locally refine bio-oil into bio-kerosene, researched the environmental impacts of cultivation and refinement facilities in Hawaii, and studied the resultant cost per gallon of bio-kerosene production. Based on the current state of technology and the proposed system of systems architecture, this report estimates that bio-kerosene can be produced for \$8.00–22.87/gal, indicating that although this system is technically feasible, it is unlikely to be affordable at current fuel prices without ongoing subsidy or further technical innovation.				
<b>14. SUBJECT TERMS</b> Biofuel, Algal Oil, Green Crude, Bio-kerosene, Hawaii, Energy Security, Naval Aviation Fuel			<b>15. NUMBER OF PAGES</b> 560	
			<b>16. PRICE CODE</b>	
<b>17. SECURITY CLASSIFICATION OF REPORT</b> Unclassified	<b>18. SECURITY CLASSIFICATION OF THIS PAGE</b> Unclassified	<b>19. SECURITY CLASSIFICATION OF ABSTRACT</b> Unclassified	<b>20. LIMITATION OF ABSTRACT</b> UU	

THIS PAGE INTENTIONALLY LEFT BLANK

**Approved for public release; distribution is unlimited**

**HAWAII ALGAL BIOFUEL**

Cohort 311-113A, Team HNAABS

Affandy, Gabriel	Allen, Charles	Black, Jesse
Bridges, Donald	Brown, Scott	Clark, John
Daniels, Quinn	Dobrowolski, Valerie	Janer, Todd
Janicek, Drew	Jeffries, Jessica	Johnson, Jeffrey
Martin, Julia	McGovern, Jonathan	Morris, Matthew
Poling, Edward	Praschak, Megan	Rogers, Michael
Schmalz, Jordan	Soques, Christopher	Thomas, David

Submitted in partial fulfillment of the  
requirements for the degree of

**MASTER OF SCIENCE IN SYSTEMS ENGINEERING**

Broadnax, Kevin	Campbell, Karolyn	Kamara, Joseph
Racelis, Edwin		Relova, Mark

Submitted in partial fulfillment of the  
requirements for the degree of

**MASTER OF SCIENCE IN ENGINEERING SYSTEMS**

from the

**NAVAL POSTGRADUATE SCHOOL  
March 2013**

Lead Editor: \_\_\_\_\_  
Kevin Broadnax

Reviewed By:

\_\_\_\_\_  
Dr. David H Olwell  
Capstone Project Advisor

\_\_\_\_\_  
Mr. Joseph W Sweeney III  
Project Advisor

Accepted By:

\_\_\_\_\_  
Dr. Clifford A Whitcomb  
Systems Engineering Department

THIS PAGE INTENTIONALLY LEFT BLANK

## **ABSTRACT**

This report investigates the feasibility and affordability of producing algae-derived biofuel in Hawaii for military aviation. The authors evaluated methods for cultivation of algae, investigated the processes necessary to locally refine bio-oil into bio-kerosene, researched the environmental impacts of cultivation and refinement facilities in Hawaii, and studied the resultant cost per gallon of bio-kerosene production. Based on the current state of technology and the proposed system of systems architecture, this report estimates that bio-kerosene can be produced for \$8.00–22.87/gal, indicating that although this system is technically feasible, it is unlikely to be affordable at current fuel prices without ongoing subsidy or further technical innovation.

THIS PAGE INTENTIONALLY LEFT BLANK

# TABLE OF CONTENTS

<b>I.</b>	<b>INTRODUCTION.....</b>	<b>1</b>
<b>A.</b>	<b>BACKGROUND .....</b>	<b>1</b>
1.	<b>History.....</b>	<b>1</b>
2.	<b>Fuel Consumption Outlook.....</b>	<b>2</b>
3.	<b>Biofuel Efforts and Challenges .....</b>	<b>4</b>
<b>B.</b>	<b>DEFINING THE PROBLEM.....</b>	<b>5</b>
1.	<b>Problem Definition.....</b>	<b>5</b>
2.	<b>Scope.....</b>	<b>6</b>
<b>C.</b>	<b>PROJECT TEAM.....</b>	<b>9</b>
1.	<b>Project Tasking .....</b>	<b>9</b>
2.	<b>Association with NAVSEA Capstone .....</b>	<b>11</b>
<b>D.</b>	<b>SYSTEMS ENGINEERING PROCESS.....</b>	<b>12</b>
1.	<b>Organization.....</b>	<b>12</b>
2.	<b>Cultivation Component .....</b>	<b>15</b>
3.	<b>Refinement Component.....</b>	<b>15</b>
<b>E.</b>	<b>PROJECT DELIVERABLES .....</b>	<b>16</b>
<b>II.</b>	<b>PROBLEM FORMULATION .....</b>	<b>17</b>
<b>A.</b>	<b>NEEDS ANALYSIS .....</b>	<b>17</b>
1.	<b>Stakeholder Analysis .....</b>	<b>17</b>
2.	<b>Needs and Constraints.....</b>	<b>21</b>
<b>B.</b>	<b>FUNCTIONAL ANALYSIS .....</b>	<b>23</b>
1.	<b>Functional Decomposition.....</b>	<b>23</b>
a.	<i>Cultivation Functional Decomposition .....</i>	<i>26</i>
b.	<i>Refinement Functional Decomposition .....</i>	<i>28</i>
2.	<b>HNAABS Tier 1 Functions.....</b>	<b>29</b>
3.	<b>Cultivation Functions .....</b>	<b>33</b>
a.	<i>Cultivate Algal Biostock (2.1) Functions .....</i>	<i>35</i>
b.	<i>Extract Green Crude (2.2) Functions .....</i>	<i>37</i>
c.	<i>Dewater Algal Biostock By-Product (2.3) Functions .....</i>	<i>39</i>
d.	<i>Store Biostock Harvest Products (2.4) Functions .....</i>	<i>41</i>
4.	<b>Refinement Functions.....</b>	<b>42</b>
a.	<i>Receive Green Crude (4.1) Functions.....</i>	<i>44</i>
b.	<i>Refine Green Crude (4.2) Functions.....</i>	<i>45</i>
c.	<i>Manage By-products (4.3) Functions. ....</i>	<i>48</i>
d.	<i>Post-Process Refined Product (4.4) Functions.....</i>	<i>52</i>
e.	<i>Manage Refining Resources (4.5) Functions .....</i>	<i>53</i>
<b>C.</b>	<b>FEASIBILITY OBJECTIVES .....</b>	<b>54</b>
1.	<b>Performance Objectives .....</b>	<b>54</b>
2.	<b>Environmental Objectives.....</b>	<b>55</b>
3.	<b>Cost Objectives.....</b>	<b>55</b>
<b>III.</b>	<b>SYSTEM DESIGN.....</b>	<b>57</b>

<b>A.</b>	<b>SYSTEM DESIGN PROCESS .....</b>	<b>57</b>
1.	Methodology and Approach.....	58
a.	<i>Cultivation Analysis of Alternatives Method .....</i>	<i>58</i>
b.	<i>Refinement Analysis of Alternatives Method.....</i>	<i>64</i>
2.	Alternatives Selection Process .....	65
a.	<i>Cultivation System Alternatives.....</i>	<i>65</i>
b.	<i>Refinement System Alternatives .....</i>	<i>66</i>
<b>B.</b>	<b>CULTIVATION SYSTEM .....</b>	<b>66</b>
1.	Background .....	66
a.	<i>Process Description.....</i>	<i>66</i>
b.	<i>Cultivation Scope .....</i>	<i>68</i>
2.	Growth Subsystem Alternatives Analysis.....	69
a.	<i>Scope and Background .....</i>	<i>69</i>
b.	<i>Alternatives Investigated.....</i>	<i>71</i>
c.	<i>Environmental Considerations.....</i>	<i>85</i>
d.	<i>Scoring.....</i>	<i>89</i>
e.	<i>Recommendations .....</i>	<i>110</i>
3.	Harvest Subsystem Analysis of Alternatives .....	115
a.	<i>Scope and Background .....</i>	<i>115</i>
b.	<i>Alternatives Investigated.....</i>	<i>117</i>
c.	<i>Scoring.....</i>	<i>129</i>
d.	<i>Sensitivity Analysis.....</i>	<i>146</i>
e.	<i>Recommendations .....</i>	<i>151</i>
4.	Dewatering Subsystem Analysis of Alternatives.....	152
a.	<i>Scope and Background .....</i>	<i>152</i>
b.	<i>Development.....</i>	<i>155</i>
c.	<i>Alternatives Investigated.....</i>	<i>156</i>
d.	<i>Environmental Considerations.....</i>	<i>165</i>
e.	<i>Scoring.....</i>	<i>167</i>
f.	<i>Recommendations .....</i>	<i>182</i>
5.	Extraction Subsystem Analysis of Alternatives .....	183
a.	<i>Scope and Background .....</i>	<i>183</i>
b.	<i>Alternatives Investigated.....</i>	<i>184</i>
c.	<i>Scoring.....</i>	<i>191</i>
d.	<i>Recommendations .....</i>	<i>208</i>
6.	Results and Recommendations .....	214
<b>C.</b>	<b>REFINEMENT SYSTEM.....</b>	<b>214</b>
1.	Background .....	215
a.	<i>Refinement History and Progress.....</i>	<i>216</i>
b.	<i>Scope.....</i>	<i>218</i>
c.	<i>Hawaii Oil Refinement Situation .....</i>	<i>219</i>
2.	Requirements Allocation .....	224
3.	System Configuration Analysis.....	226
4.	Algal Oil Composition and Hydrotreating .....	232
a.	<i>Corrosion.....</i>	<i>235</i>

	<i>b.</i>	<i>Thermal Stability</i> .....	235
	<i>c.</i>	<i>Chemical Stability</i> .....	236
	<i>d.</i>	<i>Polarity</i> .....	236
	<i>e.</i>	<i>Viscosity</i> .....	236
	<i>f.</i>	<i>Hydrotreating Catalyst Optimization</i> .....	237
5.		<b>Resource Utilization</b> .....	244
	<i>a.</i>	<i>Energy Utilization</i> .....	244
	<i>b.</i>	<i>Water Utilization</i> .....	247
	<i>c.</i>	<i>Land and Location</i> .....	253
	<i>d.</i>	<i>Manpower</i> .....	257
6.		<b>By-Product Stream Analysis</b> .....	260
	<i>a.</i>	<i>By-products</i> .....	260
	<i>b.</i>	<i>EPA Hazardous Wastes and Land Disposal Restrictions (LDR) Treatment Standards</i> .....	262
	<i>c.</i>	<i>Process Water Treatment</i> .....	262
	<i>d.</i>	<i>Sludge Treatment</i> .....	265
	<i>e.</i>	<i>Carbon Capture and Storage/Sequestration (CCS)</i> .....	266
	<i>f.</i>	<i>Hydrogen Recovery and Purification</i> .....	267
	<i>g.</i>	<i>Tesoro and Chevron By-Product Quantities</i> .....	269
7.		<b>System Alternatives Analysis</b> .....	270
	<i>a.</i>	<i>Retrofitting a Petroleum Refinery</i> .....	270
	<i>b.</i>	<i>Building a New Green Crude Refinery in Hawaii</i> .....	272
	<i>c.</i>	<i>Hybrid Alternative</i> .....	274
8.		<b>Results and Recommendations</b> .....	276
IV.		<b>ENVIRONMENTAL AND LEGAL CONSTRAINTS</b> .....	279
	A.	<b>BACKGROUND</b> .....	279
	B.	<b>ENVIRONMENTAL AND LEGAL ANALYSIS SCOPE</b> .....	280
	C.	<b>ENVIRONMENTAL IMPACTS</b> .....	282
	1.	<b>System Impacts</b> .....	282
		<i>a. Water</i> .....	282
		<i>b. Land</i> .....	287
		<i>c. Air</i> .....	291
	2.	<b>Energy Impacts</b> .....	292
	D.	<b>REGULATIONS AND PERMITS</b> .....	293
	E.	<b>ENVIRONMENTAL RISKS AND MITIGATION STRATEGIES</b> .....	299
	1.	<b>Risk Identification</b> .....	299
	2.	<b>Risk Mitigation Strategies</b> .....	299
		<i>a. Risk 1: Invasive Algae</i> .....	299
		<i>b. Risk 2: Regulation Requirements</i> .....	300
		<i>c. Risk 3: Air Emission Levels</i> .....	301
		<i>d. Risk 4: Untreated Wastewater Discharge</i> .....	302
		<i>e. Risk 5: Water Consumption Level</i> .....	302
		<i>f. Risk 6: Land Use Complications</i> .....	303
	F.	<b>ENVIRONMENTAL METRICS</b> .....	304
	G.	<b>RESULTS AND RECOMMENDATIONS</b> .....	305

V.	<b>FINDINGS AND RECOMMENDATIONS</b>	308
A.	<b>FINAL CONFIGURATION ANALYSIS</b>	308
1.	Configuration Alternative 1	309
2.	Configuration Alternative 2	311
B.	<b>FEASIBILITY AND COST ANALYSIS</b>	312
1.	Affordability Cost Objective	312
2.	Cost Estimate Creation and Assumptions	312
3.	Cost of Intersystem Transport	315
4.	Cost of Growth System	318
a.	<i>Growth Operations Cost</i>	319
b.	<i>Growth Capital Cost</i>	321
c.	<i>Growth Manpower Cost</i>	322
5.	Cost of Oil Extraction Process	323
a.	<i>Oil Extraction Capital Cost</i>	323
b.	<i>Oil Extraction Operations Costs</i>	324
c.	<i>Oil Extraction Manpower Costs</i>	326
6.	Cost of Dewatering	326
a.	<i>Dewatering Capital Costs</i>	327
b.	<i>Dewatering Operations Costs</i>	328
c.	<i>Dewatering Manpower Costs</i>	329
7.	HNAABS Cultivation Life Cycle Cost	330
8.	Cost of Refinement Process	330
a.	<i>Refinement Capital Costs</i>	331
b.	<i>Refinement Operations Costs</i>	331
c.	<i>Refinement Manpower Costs</i>	334
9.	HNAABS Refinement Annual Operating Cost	335
10.	Cost Benefit Analysis	335
11.	Budget and Resource Analysis	337
12.	Cost Analysis Conclusions and Recommendations	338
a.	<i>Cost Excursions</i>	339
C.	<b>CONCLUSIONS AND FURTHER RESEARCH</b>	341
	<b>APPENDIX A. PERFORMANCE SPECIFICATION</b>	344
A.	<b>SCOPE</b>	344
1.	Scope	344
2.	System Description	344
B.	<b>APPLICABLE DOCUMENTS</b>	344
C.	<b>REQUIREMENTS</b>	345
1.	General	345
a.	<i>System of Systems</i>	345
b.	<i>Throughput</i>	345
c.	<i>Operational Availability</i>	345
d.	<i>Free On-Board Fuel Cost</i>	346
e.	<i>Regulatory Constraints</i>	347
f.	<i>Cultivation Subsystem Requirements</i>	347
g.	<i>Refinement Subsystem Requirements</i>	347

	<i>h. Logistics</i> .....	347
D.	VERIFICATION.....	348
E.	PACKAGING.....	348
<b>APPENDIX B. PROJECT MANAGEMENT PLAN</b> .....		<b>350</b>
A.	INTRODUCTION.....	350
	1. Problem Statement.....	350
	2. Project Scope .....	351
	3. Stakeholders .....	352
	4. Assumptions.....	353
	5. Deliverables .....	353
B.	APPLICABLE DOCUMENTS.....	354
C.	SCHEDULE.....	354
D.	PROJECT ORGANIZATION.....	354
	1. Project Team .....	354
	2. Roles and Responsibilities .....	355
	<i>a. Requirements IPT</i> .....	356
	<i>b. Cultivation IPT</i> .....	356
	<i>c. Refinement IPT</i> .....	356
	<i>d. Environmental IPT</i> .....	357
	<i>e. Cost IPT</i> .....	357
	<i>f. COR3</i> .....	358
E.	MANAGEMENT PROCESS.....	358
	1. Work Breakdown Structure .....	359
	2. Risk Management Process .....	360
	3. Communications .....	364
F.	TECHNICAL APPROACH.....	365
	1. System Model .....	365
	2. Cultivation System.....	365
	<i>a. Cultivation System Description</i> .....	366
	<i>b. Technical Performance Measures</i> .....	369
	<i>c. Data Items</i> .....	369
	<i>d. Cultivation Functional Analysis</i> .....	370
	3. Refinement System.....	371
	<i>a. Refinement System Description</i> .....	371
	<i>b. Technical Performance Measures</i> .....	372
	<i>c. Data Items</i> .....	373
	<i>d. Functional Analysis</i> .....	373
	4. Environmental.....	374
	<i>a. Environmental Concerns</i> .....	375
	<i>b. Legal Concerns</i> .....	376
	5. Design Verification.....	377
	<i>a. Requirements Verification</i> .....	378
	<i>b. Cost Analysis</i> .....	378
G.	MODELS, TOOLS, TECHNIQUES.....	380
H.	PROJECT DATA.....	382

1.	HNAABS SYSTEM LEVEL REQUIREMENTS .....	382
2.	HNAABS Work Breakdown Structure.....	385
<b>APPENDIX C. RISK MANAGEMENT PLAN .....</b>		<b>387</b>
A.	<b>INTRODUCTION.....</b>	<b>387</b>
1.	Purpose.....	387
2.	Objectives.....	388
3.	Scope and Context.....	388
4.	<b>GUIDING PRINCIPLES .....</b>	<b>390</b>
B.	<b>RISK MANAGEMENT ORGANIZATION .....</b>	<b>390</b>
1.	Risk Management Organization.....	391
2.	Risk Management Team (RMT).....	391
3.	Risk Originator .....	392
4.	Risk Owner .....	392
5.	Project Management Team (PMT) .....	393
C.	<b>RISK MANAGEMENT INFORMATION.....</b>	<b>393</b>
1.	Detailed Risk Attributes .....	393
2.	Risk Reference Model.....	395
D.	<b>RISK MANAGEMENT PROCESS .....</b>	<b>396</b>
1.	Risk Management Planning .....	396
a.	<i>Development of the Risk Management Plan (RMP) .....</i>	<i>397</i>
b.	<i>Identification of Candidate Risk Reference Models (RRM).....</i>	<i>397</i>
c.	<i>Selection of HNAABS Risk Reference Model (RRM).....</i>	<i>397</i>
2.	Risk Management Execution .....	397
a.	<i>Submit Risk .....</i>	<i>398</i>
b.	<i>Assess Risk.....</i>	<i>398</i>
c.	<i>Evaluate Risk.....</i>	<i>400</i>
d.	<i>Mitigate Risk .....</i>	<i>401</i>
3.	Risk Management Closeout .....	405
4.	Risk Escalation Procedures.....	405
5.	Risk Management Team Meeting.....	406
6.	Feedback and Reporting Processes .....	406
a.	<i>Risk Watch List .....</i>	<i>407</i>
b.	<i>Risk Meeting Report.....</i>	<i>407</i>
E.	<b>OPPORTUNITY MANAGEMENT.....</b>	<b>408</b>
F.	<b>RISK MANAGEMENT TOOL .....</b>	<b>409</b>
1.	Using the Risk Summary Form .....	409
a.	<i>Identifying a Risk.....</i>	<i>410</i>
b.	<i>Create New Action Items .....</i>	<i>410</i>
c.	<i>Viewing/Updating an Action Items .....</i>	<i>411</i>
2.	Weekly Risk Minutes.....	411
G.	<b>PERFORMANCE MEASURES.....</b>	<b>411</b>
<b>APPENDIX D. LEGAL AND REGULATORY FRAMEWORK.....</b>		<b>413</b>
<b>APPENDIX E. TREATMENT STANDARDS FOR TOXIC WASTES.....</b>		<b>417</b>

<b>APPENDIX F. HNAABS RISK ASSESSMENT .....</b>	<b>421</b>
<b>A. INTRODUCTION.....</b>	<b>421</b>
1. Purpose.....	421
2. Scope.....	421
<b>B. RISK ASSESSMENT APPROACH.....</b>	<b>421</b>
<b>C. RISK ASSESSMENT PROCESS .....</b>	<b>422</b>
1. Early-Preparation Phase (Summer Quarter).....	423
<i>a. Tracked Risks .....</i>	<i>425</i>
<i>b. Accepted Risks.....</i>	<i>428</i>
2. Research Phase (Fall Quarter) .....	431
3. Development Phase (Winter Quarter) .....	435
<i>a. Development Phase Risk Submissions .....</i>	<i>435</i>
<i>b. Risk Status .....</i>	<i>437</i>
<i>c. Risks Mitigated.....</i>	<i>439</i>
<i>d. Risks Open.....</i>	<i>443</i>
<i>e. Risks Closed.....</i>	<i>445</i>
<b>D. CONCLUSION .....</b>	<b>445</b>
<b>APPENDIX G. TRACKED RISKS.....</b>	<b>447</b>
<b>APPENDIX H. ACCEPTED RISK.....</b>	<b>495</b>
<b>APPENDIX I. AOA RISK SUBMISSION.....</b>	<b>497</b>
<b>APPENDIX J. FUTURE RISK ASSESSMENT .....</b>	<b>499</b>
<b>APPENDIX K. HNAABS CULTIVATION AOA TEAMS .....</b>	<b>500</b>
<b>APPENDIX L. NON-TRACKED RISKS CLOSED .....</b>	<b>501</b>
<b>LIST OF REFERENCES .....</b>	<b>504</b>
<b>INITIAL DISTRIBUTION LIST .....</b>	<b>525</b>

THIS PAGE INTENTIONALLY LEFT BLANK

## LIST OF FIGURES

Figure 1.	DoD energy consumption trends (From Karbuz 2007). .....	1
Figure 2.	Oil spot prices in \$/bbl since 1986 (From U.S. Energy Information Administration 2013). .....	3
Figure 3.	Enterprise model for biofuel production and use, showing critical gap in the process (From Simonpietri 2011, p.17). .....	6
Figure 4.	Proposed HNAABS system of systems diagram showing key interfaces and boundaries. ....	8
Figure 5.	HNAABS team organization breakdown showing the top level IPT structure.....	9
Figure 6.	HNAABS systems engineering/project cycle model. ....	13
Figure 7.	Produce Biofuel (1.0) functional decomposition (hierarchy diagram). ....	25
Figure 8.	Produce Algal Oil (2.0) functional decomposition (hierarchy diagram). ....	27
Figure 9.	Refine Algal Crude (4.0) functional decomposition (hierarchy diagram). ....	29
Figure 10.	Produce Biofuel (1.0) functional analysis (IDEF0). ....	31
Figure 11.	System functional decomposition example (IDEF0). ....	32
Figure 12.	Produce Algal Oil (2.0) functional decomposition (IDEF0). ....	34
Figure 13.	Cultivate Algal Biostock (2.1) functional decomposition (IDEF0). ....	36
Figure 14.	Extract Green Crude (2.2) functional decomposition (IDEF0) .....	38
Figure 15.	Dewater Algal Biostock By-Product (2.3) functional decomposition (IDEF0). ....	40
Figure 16.	Store Biostock Harvest Products (2.4) functional decomposition (IDEF0). ...	41
Figure 17.	Refine Algal Crude (4.0) functional decomposition (IDEF0). ....	43
Figure 18.	Receive Green Crude (4.1) functional decomposition (IDEF0). ....	45
Figure 19.	High-level architecture of the HNAABS refinement process.....	45
Figure 20.	Molecular structure change during hydrocracking process. ....	47
Figure 21.	Refine Green Crude (4.2) functional decomposition (IDEF0). ....	48
Figure 22.	Manage By-products (4.3) functional decomposition (IDEF0). ....	49
Figure 23.	Manage Liquid & Solid By-products (4.3.1) functional decomposition. ....	50
Figure 24.	Manage Gaseous By-product (4.3.2) functional decomposition (IDEF0). ....	51
Figure 25.	Post-Process Refined Product (4.4) functional decomposition (IDEF0). ....	52
Figure 26.	Manage Refining Resources (4.5) functional decomposition (IDEF0). ....	53
Figure 27.	Graphical description of the cultivation system configuration selection. Based on the analysis alternatives results, various final configurations were chosen for final selection for the HNAABS cultivation system. ....	59
Figure 28.	Diagram of the general decision analysis performed to determine the final configuration of the cultivation system. The process is derived from AHP, QFD, and Pareto optimization processes. ....	61
Figure 29.	QFD process utilizing requirements priorities to determine the weighting each component has within a given subsystem. This process was performed for each of the four cultivation subsystem analyses of alternatives. This flow shows the actual matrices resulting from the growth analysis of alternatives. ....	63

Figure 30.	Performance, cost risk, and environment scoring to compare each alternative investigated. The results of these scores are weighted and normalized so that each of the three dimensions can be compared against each other in a simple Pareto Optimization for final trade-off selection. ....	64
Figure 31.	Refinement configurations analyzed. A business case analysis was performed for the different refinement options available for the HNAABS configuration. ....	65
Figure 32.	Algal biofuels process diagram. The cultivation system design was divided into the four stages of cultivation: growth, harvesting, dewatering, and extraction (From Darzins and Knoshaug 2011). ....	67
Figure 33.	Open raceway pond system showing the growth process and flow (From Algae-Energy 2013). ....	74
Figure 34.	Aerial view of the open pond system (pond system on right, power plant on left) utilized at the Kauai Algae Farm (From Hawaii Congress of Planning Officials 2012). ....	76
Figure 35.	Process flow for photobioreactor systems(From ReThink Factory 2013). ....	77
Figure 36.	Algae farm demonstration facility in Kona, Hawaii utilizing hybrid growth method with photobioreactors (right) and open pond systems (left) (From Cellana 2013). ....	81
Figure 37.	Hybrid cultivation system functional flow (From Ryan 2009). ....	82
Figure 38.	OMEGA growth facility (From J. Trent, OMEGA For the Future of Biofuels, 2010). ....	83
Figure 39.	Concept of operations for the OMEGA facility (From Austin 2010). ....	84
Figure 40.	Initial OMEGA design alternatives (From NASA URS, 2010). ....	85
Figure 41.	Growth subsystem cost vs. performance chart showing that pond and photobioreactor alternatives within the efficient frontier (shown in red). Photobioreactor has higher performance with higher cost risk and pond has lower performance with lower performance. The other alternatives are not within the efficient frontier. ....	108
Figure 42.	Growth subsystem environmental vs. performance chart showing that pond, photobioreactor, and OMEGA alternatives within the efficient frontier (shown in red). Photobioreactor has higher performance with higher environmental risk and OMEGA has lower performance with lower environmental risk. ....	109
Figure 43.	Growth subsystem cost vs. environmental chart showing that all alternatives except hybrid are within the efficient frontier (shown in red). Photobioreactor is closest to the best possible score (bottom-left). ....	110
Figure 44.	Harvesting as a part of the overall cultivation process (After Green, Shelef, & Sukenik, 1984). ....	116
Figure 45.	Perforate decanter centrifuge showing the general process by which the growth output enters the centrifuge and the biomass is discharged (From Margaritis, 2007). ....	119
Figure 46.	Visual representation of the chemical flocculation process showing the process by which algae cells aggregate and sink to the bottom of a container (From Algae Biodiesel 2013). ....	123

Figure 47.	Photo of sedimentation tanks at Cellana facility taken by HNAABS team during fact finding trip to Hawaii. ....	125
Figure 48.	Example decantation process showing the process by which biomass is separated from oil and water (After Sims 2011).....	126
Figure 49.	Diagram showing the path of air and concentrated biomass in a froth flotation system (From EnglishInfo 2013).....	128
Figure 50.	Cost of rectangular froth flotation system (From Aulenbach, et al. 2010). ...	129
Figure 51.	Harvest subsystem cost vs. performance comparison.....	144
Figure 52.	Harvest subsystem cost vs. environmental comparison.....	145
Figure 53.	Harvest subsystem environmental vs. performance comparison. ....	146
Figure 54.	Settling tanks.....	154
Figure 55.	Centrifuge. ....	155
Figure 56.	Ring heater. ....	155
Figure 57.	Dry algae.....	155
Figure 58.	Side view of a cyclone portion of the fluidized bed dryer showing details of the drying methodology (From Amos 1998).....	157
Figure 59.	Diagram of the full fluidized bed system. Algae travels along the drying bed before being fine algae particles are launched into the cyclone for drying and recapture (From Li and Finney 2010).....	158
Figure 60.	Screw conveyer dryer side view to show system function (From Mujumdar 2011). ....	159
Figure 61.	Notional flash milling dryer to show system functionality (From Crown Iron Works Company 2012). ....	161
Figure 62.	Notional superheated steam dryer showing the major components of system functionality (From Amos 1998). ....	163
Figure 63.	Single-pass rotary dryer (From Amos 1998). ....	164
Figure 64.	Industrial direct heat rotary drying system design diagram (From Mujumdar 2011). ....	164
Figure 65.	Dewater Subsystem Environmental vs. Performance Comparison .....	180
Figure 66.	Dewater subsystem cost vs. performance comparison. ....	181
Figure 67.	Dewater subsystem cost vs. environmental comparison.....	181
Figure 68.	Commercially available expeller press using a screw device; motor not shown. (From Hunan Double Elephants Machinery Company 2013).....	186
Figure 69.	A column filled with algae/DME mixture (From Central Research Institute of the Electric Power Industry 2010).....	187
Figure 70.	A concept illustration of the Single-step Oil Extraction™ method patented by OriginOil™; The inset shows a cutaway view of the Quantum Fracturing™ extraction chamber (From OriginOil, Inc. 2013). ....	189
Figure 71.	Examples of atmospheric decompression chambers used in a recent study (From Science Applications International Corporation 2010).....	190
Figure 72.	Cost vs. Performance Chart – The extraction methods within the trade-space are shown in red. ....	206
Figure 73.	Environmental vs. performance chart – the extraction methods on the efficient frontier are shown in red.....	207

Figure 74.	Cost vs. environmental chart – the extraction methods on the efficient frontier are shown in red. ....	207
Figure 75.	Gravity clarifier as illustrated for the Quantum Fracturing™ process by OriginOil. ....	212
Figure 76.	Infrastructure of typical petroleum crude oil refinery (From Britannica 2012). ....	227
Figure 77.	Typical two-stage hydrocracker set up (From Citizendium 2012). ....	229
Figure 78.	Typical fractional distillation tower set up (From Beychok 2013). ....	230
Figure 79.	HNAABS refinery physical architecture spider diagram. ....	231
Figure 80.	API separator (From IPIECA 2010, p. 28). ....	232
Figure 81.	Media filtration system (From IPIECA 2010, 45). ....	232
Figure 82.	Example of the expected HNAABS autoclave batch reactor configuration. (From Wildschut et al. 2009) ....	240
Figure 83.	Reaction product comparison between mild (top) and deep (bottom) which illustrates less loss of product with the deep conditions (From Wildschut et al. 2009) ....	241
Figure 84.	Reaction yield comparison between mild (top) and deep (bottom) that shows Ru/C provides the lowest oxygen content/yield percent under deep conditions (From Wildschut et al. 2009) ....	243
Figure 85.	Energy consumed by the petroleum industry (trillion Btu) (From U.S. Energy Information Administration 2006). ....	245
Figure 86.	Hydrogen supply chemical reactions (From U.S. Department of Energy 2012). ....	247
Figure 87.	High level view of water requirements in a typical refinery (From Wu and Chiu 2011). ....	248
Figure 88.	High level view of water system in a typical refinery (From Wu and Chiu 2011). ....	251
Figure 89.	High level view of water loss in a typical refinery (From Nabzar and Duplan 2011). ....	253
Figure 90.	Oil refinery throughput compared to the number of full-time employees (Data compiled from oil refining company websites by the HNAABS Team). ....	257
Figure 91.	Oil refinery throughput (<200k bbl/day) compared to full-time employees. ....	258
Figure 92.	Typical refinery process water treatment (From IPIECA 2010, 25). ....	264
Figure 93.	API sludge treatment system (After IPIECA 2010, 40). ....	265
Figure 94.	DGF/IGF float treatment system (From IPIECA 2010, 41). ....	266
Figure 95.	Biological sludge treatment system (From IPIECA 2010, 41). ....	266
Figure 96.	Polybed PSA system flow scheme (From UOP, A Honeywell Company 2011). ....	268
Figure 97.	Polysep membrane system flow scheme (From UOP, A Honeywell Company 2011). ....	268
Figure 98.	Tesoro and Chevron by-product quantities (After U.S. Environmental Protection Agency 2012 and Hawaii Foreign-Trade Zone 2013). ....	269
Figure 99.	System architecture for hybrid refinery alternative. ....	275

Figure 100.	Environmental analysis breakdown structure showing the major areas investigated for environmental and regulatory impacts. There are different impacts to consider depending on whether the growth system is an open-type like the pond or closed like the photobioreactor. ....	281
Figure 101.	Water consumption of an open pond cultivation system versus a closed photo-bioreactor (PBR) cultivation system when 10 million gallons per year of algae lipid content is produced. This is based on EPA assumptions and should only be used for comparison of pond and PBR cultivation methods. (After U.S. Environmental Protection Agency 2010). ....	286
Figure 102.	Describes the land requirements (in acres) for production 10 million gallons of algae lipid content for the open pond system versus the photobioreactor system. This is based on EPA estimation and should only be used to compare the open pond and PBR systems. This is a critical issue due to the fact that the system shall be located in Hawaii where usable land is scarce, valued, and protected. ....	288
Figure 103.	Land boundaries of the Hawaiian island of Hawai`i showing the various district regions with most of the land identified for conservation purposes only (From Land Use Commission Department of Business, Economic Development, and Tourism; State of Hawaii 2013). ....	291
Figure 104.	The amount of energy required for producing 10 million gallons of algae lipid content. This chart shows the difference of energy used for the open pond system versus the photobioreactor system for cultivating algae. This is an EPA estimation and should only be used to compare the open pond and PBR systems. ....	293
Figure 105.	The regulatory and issuing permit authorities required for construction of a algae biofuel production facility within the state of Hawaii along with the product permits and certificates. ....	298
Figure 106.	Invasive algae risk details. ....	300
Figure 107.	Regulation requirements risk details. ....	301
Figure 108.	Air emission levels risk details. ....	301
Figure 109.	Untreated wastewater discharge risk details. ....	302
Figure 110.	Water consumption level risk details. ....	303
Figure 111.	Land use complications risk details. ....	303
Figure 112.	Cultivation configuration 1 concept. ....	310
Figure 113.	Intersystem transport of a single photobioreactor field cultivation system. The HNAABS configuration requires approximately 219 of these fields. ....	316
Figure 114.	Twelve sets of photobioreactor fields with main supply and output lines shown. The HNAABS configuration requires approximately 18.25 of the sets shown to make up the total 219 photobioreactor fields and the 1,221 extraction devices. ....	317
Figure 115.	Proposed HNAABS system of systems diagram, showing key interfaces. ...	344
Figure 116.	System time definition diagram. ....	346
Figure 117.	Proposed HNAABS system of systems diagram, showing key interfaces. ...	351
Figure 118.	Project organization chart. ....	354
Figure 119.	Project work breakdown structure. ....	360

Figure 120.	Risk management planning .....	360
Figure 121.	Risk management execution. ....	361
Figure 122.	Risk assessment matrix (From NAVAIRINST 5000.21B 2008).....	363
Figure 123.	Risk severity levels (From Source Selection Procedures 2011). ....	363
Figure 124.	Algal biofuels production process (From Darzins and Knoshaug 2011).....	366
Figure 125.	Cultivation ICOM. ....	370
Figure 126.	Refinement ICOM. ....	374
Figure 127.	Refinement functional diagram.....	374
Figure 128.	Environmental ICOM. ....	375
Figure 129.	Environmental spider diagram. ....	377
Figure 130.	Cost ICOM.....	380
Figure 131.	Capstone project N2 diagram.....	381
Figure 132.	Cultivation/refinement system time.....	383
Figure 133.	Reliability terms (MTBF). ....	384
Figure 134.	Overview of HNAABS risk management process.....	388
Figure 135.	HNAABS risk management organization.....	391
Figure 136.	Risk summary form used for documenting risk information.....	395
Figure 137.	Assessment of risk likelihood of occurrence (From NAVAIRINST 5000.21B 2008, Enclosure 1).....	396
Figure 138.	Risk management planning (From Defense Acquisition University 2011)....	397
Figure 139.	Risk management execution (From Defense Acquisition University 2011). ...	398
Figure 140.	Risk assessment matrix (From NAVAIRINST 5000.21B 2008, Enclosure 1). ....	399
Figure 141.	Risk levels (From Source Selection Procedures 2011).....	399
Figure 142.	Risk ownership based on risk level (After Risk Management Plan Template and Guide 2009, 24).....	401
Figure 143.	Risk management closeout (From Defense Acquisition University 2011). ...	405
Figure 144.	Opportunity management execution steps (From Defense Acquisition University 2011). ....	408
Figure 145.	Assessment matrix. ....	422
Figure 146.	Risk level descriptions. ....	422
Figure 147.	HNAABS systems engineering/project cycle model.....	423
Figure 148.	Risk pre-assessment. ....	424
Figure 149.	Early-risk submission: matrix/tracking number.....	426
Figure 150.	Early-risk submission: accepted risk. ....	430
Figure 151.	Risk submissions during AoA's. ....	433
Figure 152.	Post-AoA's risk submissions. ....	436
Figure 153.	Risk reviewed.....	438
Figure 154.	DOD matrix: refinement final risk outcome.....	439
Figure 155.	DOD matrix: cost final risk outcome.....	440
Figure 156.	DOD matrix: cultivation final risk outcome. ....	441
Figure 157.	DOD matrix: environmental final risk outcome. ....	442
Figure 158.	DOD matrix: cultivation risks open.....	443
Figure 159.	DOD matrix: cultivation/refinement risks open. ....	444

## LIST OF TABLES

Table 1.	Cultivation subsystem alternatives selected for each of the four cultivation stages. Five alternatives were chosen for each stage to keep the analysis process manageable (four for extraction). These alternatives were chosen based on a combination of general performance, cost, and technical maturity. ....	66
Table 2.	Description and of algae growth methods investigated showing list of companies or research groups with each method. Note that all methods but OMEGA have been or are planned to be utilized in Hawaii. ....	72
Table 3.	Advantages and limitations examples for growth systems (After Brennan and Owende 2009). ....	73
Table 4.	Customer prioritization results showing heavy leaning of priority to maximize algae growth output over other priorities. Note that this scoring signifies that being able to collect sellable by-products and minimizing power consumption are just as important as maximizing algae growth. ....	91
Table 5.	Growth subsystem prioritization matrix showing relative priority importance after comparing the scoring in the previous section to all other priorities. This table signifies that maximizing algae growth, minimizing power consumption, and the ability to collect sellable by-products are of top importance (After Blanchard and Fabrycky 2010). ....	93
Table 6.	Growth subsystem priorities to design characteristics matrix showing strong weighting requiring large growth capacity (18.3%) with by-product output, growth rate, and growth cycle period as other key characteristics. ....	95
Table 7.	Growth subsystem design characteristics to functions matrix. By using the weightings calculated in the previous sections (2 <sup>nd</sup> column) and the interrelationship scoring the final function weightings show that controlling growth environment being the top ranked function with agitate algae and regulate nutrients the next highest ranked functions. ....	97
Table 8.	Growth subsystem functions to physical components matrix showing control system with the highest ranking (24%) and growth medium container the next highest (21%). ....	99
Table 9.	Growth subsystem performance rating to alternatives performance comparison matrix showing raw scores on top and normalized scores on the bottom with the final weighted performance on the right. Photobioreactor has top performance score with hybrid and heterotrophic next highest. ....	101
Table 10.	Growth subsystem cost comparison analysis matrix with raw scores on the top and weighted scores on the bottom. The lower the score the lower the cost risk (better) and this shows that the pond system has the lowest cost risk with photobioreactor the next lower. ....	103
Table 11.	Growth subsystem environmental comparison analysis matrix with raw scores on the top and weighted scores on the bottom. The lower the score the lower the environmental risk (better) and shows that the OMEGA	

	system has the lowest environmental risk and the pond system being the highest environmental risk.....	104
Table 12.	Growth subsystem raw results of cost, environmental and performance weights. For cost and environmental, the lower score the better. For performance, the higher score the better. Signifies that pond has lowest cost risk, PBR has highest performance, and OMEGA has lowest environmental risk. ....	105
Table 13.	Growth subsystem normalized results of cost, environmental and performance weights to the best possible score. For cost and environmental, the lower score the better. For performance, the higher score the better. Signifies that pond has lowest cost risk, PBR has highest performance, and OMEGA has lowest environmental risk. ....	106
Table 14.	Growth subsystem top scoring alternatives in factor comparison. Showing how close a given alternative is to the best possible scores with the lower number being better. For both cost vs. performance and cost vs. environmental the photobioreactor has the best score with OMEGA showing the best environmental vs. performance score. ....	107
Table 15.	Modified requirements priority scoring for sensitivity analysis. These modified scores (blue and purple) were used in the analysis of alternatives process to determine how much the priorities scoring adjustments changed the final performance results.....	112
Table 16.	Sensitivity analysis final performance results showing no difference from original analysis of alternatives results. The best systems for each comparison are highlighted.....	113
Table 17.	Sensitivity analysis showing variation when cost represents 80% of the importance of the overall system. The 3D distance refers to the distance from the ideal point in 3-dimensional space. This ideal solution would score 0, 0, and 1 for cost, environmental impact, and performance respectively. ....	114
Table 18.	Sensitivity analysis showing variation when environmental impacts represent 50% of the importance of the overall system.....	114
Table 19.	Harvest analysis of alternatives requirements prioritization.....	132
Table 20.	Algae harvesting pairwise comparison matrix used to develop weighting factors for system requirements (After Blanchard and Fabrycky 2010).....	132
Table 21.	Harvest subsystem requirements vs. design characteristics HoQ used to develop weighted rankings for key design criteria. ....	134
Table 22.	Harvest subsystem design characteristics vs. functions used to develop weighted rankings for harvest functions. ....	135
Table 23.	Harvest subsystem functions vs. form used to develop weighted rankings for physical components. ....	136
Table 24.	Harvest subsystem comparative performance chart. ....	137
Table 25.	Harvest subsystem alternative performance scores. ....	138
Table 26.	Harvest subsystem performance results.....	138
Table 27.	Harvest subsystem environmental comparison using prioritized requirements to develop environmental scores.....	140

Table 28.	Harvest subsystem cost comparison. ....	141
Table 29.	Harvest subsystem final AoA results with raw scores.....	142
Table 30.	Harvest subsystem final AoA results with normalized scores.....	142
Table 31.	Harvest subsystem distance to ideal results showing the difference between each alternative and the ideal harvest system configuration. ....	143
Table 32.	Prioritized requirements for a design to optimize resalable by-products. ....	147
Table 33.	Performance weighting scores modified to reflect increased focus on resalable by-products. ....	147
Table 34.	Harvest environmental scores modified to reflect increased focus on resalable by-products. ....	148
Table 35.	Distance to ideal scores for excursion optimizing resalable by-products.....	149
Table 36.	Excursion to requirements prioritization maximizing the importance of the percentage of solids in the final algal slurry. ....	149
Table 37.	Distance to ideal scores for excursion optimizing percentage of solids in algal slurry. ....	150
Table 38.	Harvest system sensitivity analysis showing 3-dimensional distance-to-ideal scores when environmental impacts represent 80% of the importance of the overall system. ....	150
Table 39.	Pairwise value comparison score performed by the HNAABS team. Varying prioritizations are shown in light green, dark green, and blue. They can be altered by subject matter experts to suit a different set of program goals.....	167
Table 40.	Dewater subsystem parameter descriptions. This describes the possible system goals, and their relevant importance in relation to each other. ....	168
Table 41.	Dewater subsystem pairwise comparison matrix. The table compares the design characteristics against each other to determine their relative weighting of importance. ....	169
Table 42.	Dewater subsystem requirements priorities vs. design characteristics. This step of the HoQ process relates which measures of design quality (Characteristics) affect which final stakeholder requirements.....	171
Table 43.	Dewater subsystem design characteristics vs. functions. This matrix performs a similar comparison as the previous figure, this time relating system functionality to design measures (Characteristics). The resultant weighting shows the relative value of each system function to the user. ....	172
Table 44.	Dewater subsystem functions vs. form. Continuing the process, this matrix relates what physical structure (Form) controls which input function. The final weighting prioritizes the subsystem hardware by its relative impact on the end user's goals.....	174
Table 45.	Dewater subsystem performance comparison. The subsystems within each alternative are compared against each other, and a qualitative low, medium, high ranking was assigned. When the cross product of each ranking and performance weight is calculated, the sum of these values gives a normalized performance score to each subsystem.....	175
Table 46.	Dewater subsystem alternatives cost comparison.....	177
Table 47.	Dewater subsystem alternatives environmental comparison. ....	178

Table 48.	Dewater subsystem raw scoring results comparison. ....	179
Table 49.	Dewater subsystem normalized scoring results comparison. ....	179
Table 50.	Dewatering system sensitivity analysis showing 3-dimensional distance-to-ideal scores when performance represents 80% of the importance of the overall system. ....	182
Table 51.	Requirements prioritization - these are the extraction process scores (highlighted green) obtained by averaging the scores from each team member. ....	192
Table 52.	Extraction subsystem pairwise comparison matrix - the highest eights are highlighted green and indicated by the longer graph bars. ....	193
Table 53.	Extraction subsystem requirements to design allocation - the best scores are highlighted in blue. ....	197
Table 54.	Design characteristics to functions matrix - highest scoring functions are highlighted in blue. ....	199
Table 55.	Functions to form matrix - of the physical attributes of the conceptual oil extraction system, the most important are highlighted in blue. ....	201
Table 56.	Extraction subsystem performance AoA results - the highest scores (highlighted in green) are indicative of the best performing extraction alternative among those that were analyzed. ....	202
Table 57.	Extraction subsystem cost weighting - the best scores (lower is better) are highlighted in green. ....	204
Table 58.	Extraction subsystem environmental weighting - the best scores are highlighted bright green. ....	206
Table 59.	Results comparison for cost, performance, and environmental for the extraction subsystem analysis of alternatives. The top subsystems for each factor are highlighted in green. ....	208
Table 60.	Oil extraction system sensitivity analysis showing 3-dimensional distance-to-ideal scores when cost represents 50% of the importance of the overall system. ....	209
Table 61.	Tesoro refinery average daily throughput capacity (From Hawaii Foreign-Trade Zones 2013). ....	220
Table 62.	Tesoro export data (From Hawaii Foreign-Trade Zones 2013). ....	220
Table 63.	Refining units processing capabilities at Chevron Hawaii refinery (From A Barrel Full 2010). ....	223
Table 64.	Example of Chevron’s Hawaii refinery products and applications (After Hawaii Foreign-Trade Zones 2013). ....	223
Table 65.	Green crude and petroleum composition (After Phukan, et al. 2010; After Milner 1948; After Speight 2007). ....	233
Table 66.	Mass percentages of fatty acids in different chlorella strains (After Milner 1948). ....	233
Table 67.	Elemental composition (wt%) and heating value of hydrotreated green crude (752 °F, 493.13 psi H <sub>2</sub> ) (After Savage 2011). ....	238
Table 68.	Reaction products as compiled by the HNAABS team. ....	239
Table 69.	Water cooling configurations in a refinery (From Nabzar and Duplan 2011). ....	250

Table 70.	Land areas owned by the state of Hawaii and the U.S. Government (After J. Cooper 2012).....	255
Table 71.	Petroleum by-products for crude processed in a refinery (After World Bank 1998).....	261
Table 72.	Process water re-use (After IPIECA 2010, 42).....	263
Table 73.	Process water treatment system upgrades (From IPIECA 2010, 50).....	265
Table 74.	Recommended cultivation subsystems. ....	308
Table 75.	Cultivation configuration analyzed.....	309
Table 76.	HNAABS cultivation annual operating cost.....	314
Table 77.	HNAABS refinement annual operating cost.....	315
Table 78.	HNAABS annual operating resource requirements.....	337
Table 79.	HNAABS annual operating cost.....	339
Table 80.	Approximate HNAABS cost sensitivities (\$/gal).....	340
Table 81.	Project team as of 7/30/12. Team members have rotated positions through the course of the project.....	355
Table 82.	Likelihood rating levels (From NAVAIRINST 5000.21B 2008).....	362
Table 83.	Risk consequence levels (From NAVAIRINST 5000.21B 2008).....	362
Table 84.	Risk data elements that need to be captured for each risk that is identified (After Risk Management Plan Template and Guide 2009, p. 11-15). ....	394
Table 85.	Assessment of risk consequence to project (From NAVAIRINST 5000.21B 2008, Enclosure 1).....	396
Table 86.	Risk response strategies/techniques (From Risk Management Plan Template and Guide 2009, 22-23). ....	402
Table 87.	Risk management approval and notification guide.....	404
Table 88.	Standard risk notices and reports. ....	407
Table 89.	Risk management performance metrics (From Risk Management Plan Template and Guide 2009, 30).....	411

THIS PAGE INTENTIONALLY LEFT BLANK

## LIST OF ACRONYMS AND ABBREVIATIONS

AoA	Analysis of Alternatives
AHP	Analytic Hierarchy Process
API	American Petroleum Institute
bbbl	Barrel of Oil
CAA	Clean Air Act
CCS	Carbon Capture and Storage
CDR	Commander
CO	Carbon Monoxide
CO <sub>2</sub>	Carbon Dioxide
COTS	Commercial Off-the-shelf
COD	Chemical Oxygen Demand
CONOPS	Concept of Operations
CONUS	Continental United States
COR3	Capstone Project Lead Team
CRIEPI	Central Research Institute of the Electric Power Industry
CWA	Clean Water Act
DAF	Dissolved Air Flotation
DARPA	Defense Advanced Research Projects Agency
DBEDT	Department of Business, Economic Development and Tourism
DLNR	Department of Land and Natural Resources
DME	Dimethyl Ether
DoD	Department of Defense
DOH	Department of Health
DOTMLPF	Doctrine, Organization, Training, Materiel, Leadership and Education, Personnel and Facilities
EIS	Environmental Impact Study
EMP	Electromagnetic Pulse
EPA	Environmental Protection Agency
FAME	Fatty Acid Methyl Esters
FFA	Free Fatty Acids

FFBD	Functional Flow Block Diagram
FTZ	Foreign Trade Zone
GHG	Greenhouse Gas
GIFTPAC	Green Initiatives for Fuel Transition Pacific
H <sub>2</sub> O	Hydrogen Dioxide
HCEI	Hawaii Clean Energy Initiative
HDN	Hydrodenitrogenation
HECO	Hawaii Electric Company
HNAABS	Hawaii Naval Aviation Biofuel System
HoQ	House of Quality
IAF	Induced Air Flotation
ICOM	Inputs, Controls, Outputs, Mechanisms
IDEF	Integrated Definition for Function Modeling
IMS	Integrated Master Schedule
INCOSE	International Council on Systems Engineering
IPIECA	International Petroleum Industry Environmental Conservation Association
IPR	In-Progress Review
IPT	Integrated Product Team
IRB	Internal Review Board
KPP	Key Performance Parameter
KSA	Key System Attribute
LCAC	Landing Craft-Air Cushion
LDR	Land Disposal Restrictions
LUC	Land Use Commission
MBSE	Model Based Systems Engineering
MDT	Maintenance Downtime
MECS	Manufacturing Energy Survey
MOP	Measure of Performance
MSDS	Material Safety Data Sheet
MTBF	Mean Time Between Failure
MTBM	Mean Time Between Maintenance

MTTR	Mean Time To Repair
M&S	Modeling and Simulation
NAS	Naval Air Station
NASA	National Aeronautics and Space Administration
NAVAIR	Naval Air Systems Command
NAVSEA	Naval Sea Systems Command
NEPA	National Environmental Policy Act
NIST	National Institute of Standards and Technology
NPS	Naval Postgraduate School
O&M	Operation and Maintenance
OMEGA	Offshore Membrane Enclosures for Growing Algae
OPNAV	Office of the Chief of Naval Operations
OPS	Open Pond System
ORP	Open Raceway Pond
PBR	Photobioreactor
PESHE	Programmatic Environmental, Safety, and Occupational Health Evaluation
PMP	Program Management Plan
PSA	Pressure Swing Absorption
QF	Quantum Fracturing
QFD	Quality Function Deployment
REZ	Renewable Energy Zone
RFP	Request for Proposal
RFS	Renewable Fuel Standard
RHIB	Rigid-Hull Inflatable Boat
RMO	Risk Management Organization
RMP	Risk Management Plan
RMT	Risk Management Team
ROM	Rough Order of Magnitude
RRM	Risk Reference Model
SAIC	Science Applications International Corporation
SOS	System of Systems

SSD	Superheated Steam Drying
TAG	Triglycerides
TAN	Total Acid Number
TDS	Total Dissolved Solids
TRL	Technology Readiness Level
TSCA	Toxic Substance Control Act
TSS	Total Suspended Solids
USD	United States Dollar
USDA	United States Department of Agriculture
USPACOM	United States Pacific Command
USPACOM J81	USPACOM Energy Office
VOC	Volatile Organic Compound
YP	Yard Patrol

## EXECUTIVE SUMMARY

The United States Pacific Command (USPACOM) uses approximately 130 million gallons of aviation fuel per year. Based on possible threats to supply, the potential for economic development, and federal mandates to increase alternative fuel usage by 10% annually, USPACOM desires a method to produce 25% of this aviation fuel locally in Hawaii. A team of graduate student researchers investigated the feasibility of a system of systems capable of producing 32 million gallons of biofuel for aviation use annually within the Hawaiian Islands. The team ultimately recommended a design incorporating a photobioreactor for algae growth, an oil extraction facility utilizing electroporation, and a hybrid refinery capable of both bio-kerosene and petroleum fuel production. The team determined that, while technically feasible, the recommended system solution is not competitive with current petroleum-based fuel costs and does not meet the \$3/gal cost goal identified by USPACOM stakeholders. In addition to the recommended system design, project deliverables include a reusable framework for assessing complex biofuel production method decisions. This document describes in detail the conclusions and recommendations of the Project Team as well as the detailed systems engineering process used to arrive at these conclusions.

Initial research by the Project Team resulted in the following problem statement:

*USPACOM lacks a method to locally produce a quantity of biofuel equivalent to 25% of its annual naval aviation fuel consumption. There is currently only limited understanding of the feasibility of developing a commercially viable quantity of biofuel to meet this goal within the Hawaiian Islands.*

To address the problem statement and stakeholder needs, the Capstone Team developed a notional system design referred to in the following report as the Hawaii Naval Aviation Algae Biofuel System (HNAABS). A systems engineering process was utilized to decompose the complex problem into manageable pieces and to guide the HNAABS design approach. First, the team developed system level requirements and derived requirements based on the overarching stakeholder needs, environmental constraints, and functional requirements. Consequently, the team identified a requirement

for the design to consist of both a cultivation and refinement system to grow the algal biomatter and convert the bio-oil product into bio-kerosene respectively. As such, the HNAABS design represents a System of Systems (SOS) approach in which the cultivation and refinement systems work together to meet the user needs.

The team also identified a requirement for the HNAABS Cultivation System to produce 60 million gallons of green crude oil annually from the cultivated biomatter to support the refinement to 32 million gallons of bio-kerosene. When mixed with the appropriate additive package, this bio-kerosene product can be combined with JP-5 or JP-8 to support Department of Defense (DoD) aviation. This report does not specify or study the additive package or blending science to make useable jet fuel. However, this HNAABS design effort represents only one aspect of a broader approach to understand all facets of producing and utilizing biofuels in Hawaii. A second group of graduate student researchers simultaneously investigated the biofuel mixing process as well as a distribution system to support DoD aviation in Hawaii. Likewise, a separate graduate thesis examined the environmental litigation risks related to infrastructure development in Hawaii and the associated cost and schedule impacts based on three Hawaiian infrastructure project case studies (Stefani 2013). Together, these three products provide a more complete understanding of the challenges associated with developing a biofuel system to replace 25% of the military aviation fuel consumed annually in Hawaii.

After identifying system requirements, the team performed a functional analysis to decompose the system functions and identify key system elements. The functions were allocated to generic physical subsystems which were later modified in the final system model to reflect the recommended HNAABS design. The Cultivation system was decomposed into top-level sub-functions which were allocated to four major sub-systems: the Growth, Harvest, Dewater, and Oil Extraction subsystems. Because the Cultivation System was divided into four physical subsystems each with the opportunity for optimization, four separate Analyses of Alternatives (AoA) were conducted to develop recommended subsystem designs.

Each AoA process followed the same general procedures outlined in Figure I. The key system requirements were prioritized and translated into weighted requirements using

a portion of the Analytic Hierarchy Process (AHP) called a pairwise comparison matrix. Through Quality Function Deployment (QFD), these requirements were translated into a set of weighted functions and physical components capable of meeting key system requirements. The analysis process enabled the development of system performance rankings that were then combined with cost and environmental impact scores to develop a three-dimensional comparison space. Finally, Pareto optimization analysis was performed to determine the recommended subsystem option from each of the cost vs. performance, cost vs. environmental, and performance vs. environmental perspectives.

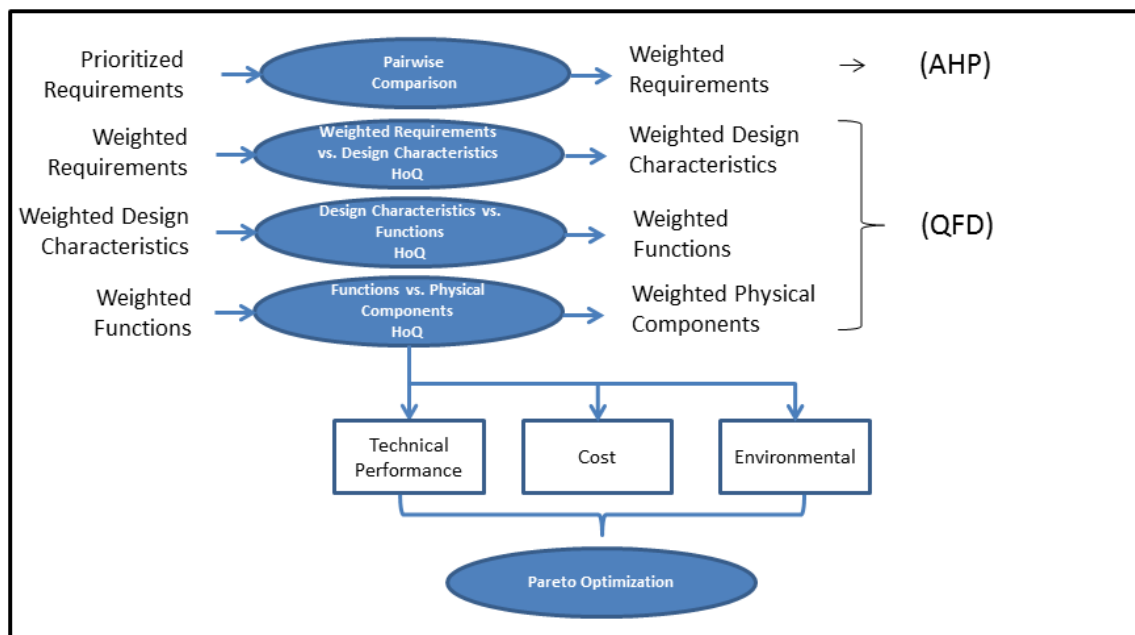

Figure I. Analysis of alternatives methodology.

Of the potential combinations of the four Cultivation subsystems, two configurations were selected for final evaluation based on the Pareto optimization results. A comparison of the two options showed that the Photobioreactor and electroporation approach offered the most affordable solution for cultivating algae and extracting the bio-oil since electroporation negates the necessity of a separate dewatering step, thereby reducing reoccurring costs and energy consumption. Detailed analysis results and supporting documentation are provided in Section V of this report. Conversely, an analysis of alternatives was not performed for the refinement architecture, as the number

of possible system configurations was too low to support this methodology. Oil is refined using standard, universal processes, and because this report does not address selection of individual part and model numbers for the refinement hardware, there was no reason to analyze the alternatives in the same manner as the Cultivation System. Instead, this paper describes a top level business case analysis for evaluating the cost and benefits of constructing a new refinery, modifying an existing refinery, or a hybrid option of adding a parallel bio-refinement capability to an existing oil refinery. Ultimately, the team concluded that a hybrid green crude refinery represents the lowest risk and most cost effective refinery option in Hawaii. The hybrid alternative offers the greatest return on investment and allows for production of petroleum fuels in parallel with bio-kerosene production.

Adding to the challenge of developing a feasible SOS design to meet USPACOM needs, a significant portion of the land in Hawaii is considered “Conservation Land”. This focus on environmental conservation is indicative of an aggressive regulatory culture for land use and facility construction. To avoid costly program delays, a detailed legal and regulatory framework was developed detailing a 42 month permitting process. Environmental risks to the local ecosystem were developed, researched, and documented, and potential risk mitigation methods were identified.

Finally, the team investigated the ability of the recommended design to meet the feasibility objectives of the HNAABS design. The feasibility analysis looked at three factors: 1) the technical feasibility of producing enough bio-kerosene to meet 25% of Hawaii's military aviation needs, 2) the environmental feasibility of producing the required quantity of fuel within the Hawaiian Islands, and 3) the cost feasibility of producing 32 million gallons of bio-kerosene at a Free On-Board cost of less than \$3/gal. The Free On-Board cost refers to the final delivered price of the bio-kerosene, equal to the fully burdened cost minus subsidies resulting from the sale of by-products.

The Cultivation System costs were broken down by subsystem as shown in Table I. The associated land, materials, electricity, and maintenance costs for each subsystem were estimated along with their impact on the total price per gallon of bio-kerosene. A similar breakdown for the HNAABS Refinement System resulted in a refinement cost of

\$1.58 per gallon of bio-kerosene. Further details on refinement costs can be found in Section V of this report. Table I shows only the annual operating costs associated with the recommended cultivation approach.

<b>HNAABS Cultivation Annual Operating Cost</b>				
	Capital Cost (\$K)	Operating Cost (\$K)	\$/Gallon Contribution	
<b>Permit Cost</b>		\$ 100		
<b>Intersystem Transport</b>		\$ 1,927	\$	0.06
Electricity Cost		\$ 1,927	\$	0.06
Infrastructure Cost	\$ 4,214	\$ -	\$	-
<b>Growth Cost - PBR</b>	\$ 195,288	\$ 175,130	\$	5.47
<b>Operations Cost</b>		\$ 80,745	\$	2.52
Land Cost		\$ 55,185	\$	1.72
Materials Cost		\$ 5,046	\$	0.16
Electricity Cost		\$ 19,715	\$	0.62
Maintenance Cost		\$ 799	\$	0.02
<b>Manpower Cost</b>		\$ 94,385	\$	2.95
<b>Oil Extraction Cost - Quantum Fracturing™</b>	\$ 256,452	\$ 31,573.1	\$	0.99
<b>Operations Cost</b>		\$ 31,481.1	\$	0.98
Land Cost		\$ 17	\$	0.00
Materials Cost		\$ -	\$	-
Electricity Cost		\$ 31,152	\$	0.97
Maintenance Cost		\$ 312	\$	0.01
<b>Manpower Cost</b>		\$ 92	\$	0.00
<b>Dewatering Cost - Flash Drying</b>	\$ 19,740	\$ 75,244	\$	2.35
<b>Operations Cost</b>		\$ 74,968	\$	2.34
Land Cost		\$ 55.4	\$	0.00
Electricity Cost		\$ 63,052	\$	1.97
Materials Cost		\$ 11,117	\$	0.35
Maintenance Cost		\$ 742.3	\$	0.02
<b>Manpower Cost</b>		\$ 276.0	\$	0.01
<b>Cultivation Annual Cost</b>	\$ 475,694	\$ 283,974	\$	8.87
<b>Biomass Resale/Tax Credit</b>		\$ (78,152)	\$	(2.44)
<b>Net Cultivation Annual Cost</b>		\$ 205,822	\$	6.43
<b>Cultivation Free On Board \$/Gallon</b>	\$ 21.30	\$ 6.43		

Table I. Free on-board cost estimate for the HNAABS cultivation approach.

The technical feasibility details are provided within the body of the report. However, the recommended system is technically capable of producing the required quantity of bio-kerosene based on subsystem performance estimates. Details associated with the environmental feasibility analysis are provided in Table II. The resulting energy,

water utilization, and land usage estimates are reasonable to support an HNAABS design located within the Hawaiian Islands. Available land estimates can support the 7,267 acres required for the cultivation and refinement processes. Furthermore, the water requirements can be met based on the decision to utilize a strain of algae that grows in saltwater.

<b>Approximate HNAABS Annual Operating Resource Requirements</b>	<b>Energy Requirement (kWh-Millions)</b>	<b>Water Utilization (Gal-Millions)</b>	<b>Land Requirement (acres)</b>
<b>Cultivation</b>	<b>331.0</b>	<b>110,269.6</b>	<b>7,242.4</b>
Transport	5.5		
Growth			
Photobioreactor	56.3		7,232.9
Oil Extraction			
Quantum Fracturing	89.0		2.2
Dewatering			
Flash Drying	180.1		7.3
<b>Refinement</b>	<b>9.7</b>	<b>71.2</b>	<b>25.0</b>
<b>Total</b>	<b>340.6</b>	<b>110,340.8</b>	<b>7,267.4</b>

Table II. Energy, water, and land resource requirements of the HNAABS design.

The HNAABS cost estimate addressed a \$3/gal cost objective for bio-kerosene production. Table III shows a current estimate of \$8.00/gal, which includes operating costs of HNAABS and cost benefit opportunity. These operating costs include electricity, maintenance, materials, manpower, and land leasing costs while the net benefit was the recouped cost from the sale of by-products. Cost analysis excursions were performed to explore the effects of variable and fixed cost drivers on the overall system cost estimates. The "Excursion 1" analysis, shown in Table III, removed the effects of drying and selling the dried biomass by-products. Because the dewatering process is only required to support by-product resale, it was eliminated as well as the cost benefit opportunity. The results show that while there is a moderate benefit of selling by-products, this benefit is almost completely negated by the costs associated with preparing the by-product for sale. Alternately, the "Excursion 2" analysis examined all non-recurring capital cost for

production equipment and operational costs. “Excursion 2” in essence estimates a potential year 1 cost of HNAABS startup, assuming resale of dried biomass. Even after accounting for the sale of by-products and the removal of non-recurring costs, the resulting estimated cost range of \$8.00 to \$22.87 per gallon remains outside the acceptable range provided by USPACOM stakeholders.

<b>Approximate HNAABS Cost Excursions (\$/gal)</b>	<b>Current Estimate</b>	<b>Excursion 1</b>	<b>Excursion 2</b>
<b>Cultivation</b>	\$ <b>6.43</b>	\$ <b>6.52</b>	\$ <b>21.29</b>
Transport	\$ 0.06	\$ 0.06	\$ 0.19
Growth	\$ 5.47	\$ 5.47	\$ 11.58
Oil Extraction	\$ 0.99	\$ 0.99	\$ 9.00
Dewatering	\$ 2.35	\$ -	\$ 2.97
Net Benefit	\$ (2.44)	\$ -	\$ (2.44)
<b>Refinement</b>	\$ <b>1.58</b>	\$ <b>1.58</b>	\$ <b>1.58</b>
<b>Total</b>	\$ <b>8.00</b>	\$ <b>8.10</b>	\$ <b>22.87</b>

Table III. HNAABS design cost estimate.

In conclusion, the HNAABS design team developed a reusable analysis process to assess algae biofuel production systems. The team used this process to develop a recommended system of systems design approach, which was feasible from a technical and environmental standpoint, but did not meet overall cost feasibility objectives. The HNAABS design represents the team's assessment of the best combination of current cultivation and refinement technologies for use within the Hawaiian Islands. Additional design files, including CORE models, are available electronically from NPS from <http://diana.nps.edu/~dholwell/HNAABS/index.htm>. Additional study of alternate algae strains and maturation of growth techniques could further improve cost competitiveness with petroleum-based fuels.

THIS PAGE INTENTIONALLY LEFT BLANK

## ACKNOWLEDGMENTS

The successful completion of the Hawaii Algae Biofuel project would not have been possible without the support of the United States Pacific Command (USPACOM) in recommending the biofuels topic and providing valuable resources to the Capstone Team; in particular, the sponsorship of the research mission that allowed face-to-face meetings with many of the primary stakeholders in Hawaii. The HNAABS Project Team would like to personally thank Dr. George Kailiwai III, SES, Director, Resources and Assessment at USPACOM J8; Commander Joelle Simonpietri USNR, Deputy, Energy Team, Innovation and Experimentation Division, USPACOM J81; Mr. Ross Roley, Energy Office Lead, USPACOM J81; and Mr. Vic Peters, Supply Management Specialist, Defense Logistics Agency Energy Pacific.

The team would also like to express their great appreciation and thanks to members of the state of Hawaii energy, education and research communities who took the time from their busy schedules to meet with us during the research mission to the state of Hawaii. They provided a wealth of knowledge, excellent feedback, and made themselves available throughout the process to answer questions. These individuals include Mr. Cameron Black and Mr. Jeffery Pang of the Hawaii State Energy Office; Mr. Robert King, President of Pacific Biodiesel; Mr. Larry Adams and Ms. Casie Gatan of Aloha Petroleum Limited; Mr. Kenneth Duabert, Plant Superintendent at Kauai Island Utility Cooperative; MST1 David Tonon, Facility Inspector for the U.S. Coast Guard; Mr. Kyle Taylor, Engineering and Operations Manager, and Dr. Xuemei Bai, Principal Research Scientists both at Cellana, LLC; Ms. Elizabeth Cole, Deputy Director of the Kohala Center; Dr. John White and Dr. Lisa Keith, USDA Research Agricultural Engineers; Dr. Vasumathi Kode, Mr. Wallace Gordon, and Mr. Mark Ritchie of Kuehnle Agrosystems; Professor Andy Hashimoto, University of Hawaii (CTAR); Scott Turn, University of Hawaii (HNEI); Mr. Bill Tam, Deputy Director of the Commission on Water Resource Management, State of Hawaii; Mr. Robert Isler, Project Manager at Hawaiian Electric Company, Inc.; Mr. Jim Rekoske, Vice President, UOP Honeywell; and Ms. Alice Burch, Chevron.

The Capstone Team would also like to thank those teammates who took time out of their busy schedules to travel to Hawaii to conduct thesis research for the team. Our travelers included: Scott Brown, Karolyn Campbell, LCDR Joseph Kamara, and David Thomas. Special thanks to the Naval Air (NAVAIR) System Commands and individuals that sponsored this research trip. The individuals responsible for providing resources to make travel possible included: Sam Thompson, Ron Scott, and Steve Farmer of Naval Air Warfare Center Weapons Division (NAWCWD) China Lake, CA; Troy St Pierre, Lezlie Morrese, Charles Gifford, Howard Hiser, and Barry Chandler of Naval Air Warfare Center Training Systems Division (NAWCTSD) Orlando, FL; CAPT Robert Caldwell and CMDR Michael Barriere of Fleet Readiness Center Southeast (FRCSE) Detachment Mayport, FL; and Joshua Wilkerson of Information and Cybersecurity, NAWCWD China Lake, CA.

Special thanks to Dr. David Olwell and Mr. Joseph W Sweeney III at the Naval Postgraduate School for being exceptional advisors and mentors throughout the capstone project for the countless hours they - spent providing the team with resources and guidance.

Thanks are also due to the other NAVAIR Commands that supported our professional development throughout our participation at NPS. These organizations include AIR 5.3.4.3 Airborne Threat Simulation; AIR 4.2.2 Operations & Support/Integrated Product Support Cost Estimating; AIR 4.5.8 Legacy Landing Systems; AIR 4.3.3 Air Vehicle Structures Engineering; AIR 5.1.6 Air Vehicle Test and Evaluation Division; AIR 4.1.1 Systems Engineering Management Division; NAWCWD China Lake 5.1 Flight Test Engineering; AIR 4.5.14 Acoustic Systems; AIR 4.5.1 Avionics Architecture & System Engineering Division; AIR 6.8.2.4 COMFRC Industrial Analysis; WD 7.2, Information Technology and Cybersecurity (ITCS) Department; NAWCWD 600000D Weapons Sustainment Support Weapons Sustainment; AIR 6.2.7 FRC Support Equipment; AIR 6.7.1.1 Design Interface; and AIR 4.3.2.3 Flight Vehicle Modeling and Simulation.

Finally, to our families and friends, that are too numerous to list, we would not have arrived at the final stage of our two-year journey without your support, encouragement, and dedication. We owe you a great debt of gratitude. Thank you.

THIS PAGE INTENTIONALLY LEFT BLANK

# I. INTRODUCTION

## A. BACKGROUND

### 1. History

The United States military accounts for a majority of the total energy consumed by the U.S. government. Moreover, oil and primarily petroleum-derived aviation fuel, accounts for more than three-fourths of the Department of Defense's (DoD) total site delivered energy consumption (Karbuz 2007). As illustrated in Figure 1, aviation fuel alone accounts for more than 50% of total DoD energy consumption and nearly 60% of its mobility fuel. Because it is a large consumer of petroleum-derived products, the DoD is dependent on petroleum to satisfy its energy needs.

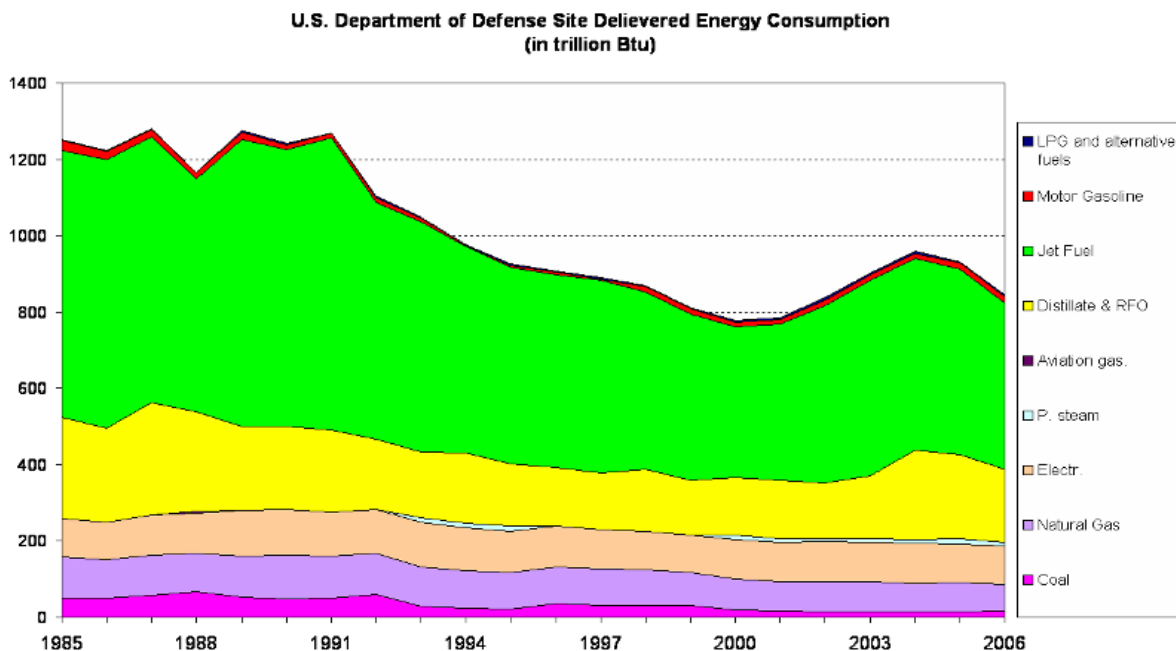

Figure 1. DoD energy consumption trends (From Karbuz 2007).

On captions, The U.S. Navy, in conjunction with other military departments within the DoD, is investing in several research efforts to minimize this dependence. The Secretary of the Navy, Ray Mabus, announced a number of energy initiatives for the

Navy in 2009, including “a 50 percent reduction in petroleum-based fuel consumption in the fleet by 2020” (Stein 2012). There are, by all appearances, many renewable sources with the potential to provide an alternative fuel to offset the diminishing supply of crude oil on the planet. However, any potential crude oil replacement efforts should consider the cost of production, availability of the renewable fuel source, and the impact on existing mechanical systems that will utilize the alternative fuel.

## **2. Fuel Consumption Outlook**

Because petroleum-based aviation fuels naturally have supply and availability limitations, there is significant interest in locating an alternate form of biologically harvested fuel, or biofuel (Seymour 2009). A cost effective and easily produced biofuel, with the ability to be grown and refined into a drop-in fuel alternative without equipment changes, would revolutionize military logistics and could lead to new commercially available biofuel for the entire aviation industry (NASA URS 2010). The demand for an alternative to petroleum based fuels is shown by the climbing cost over time (Figure 2). As the cost of petroleum based fuels continue to climb, the costs will eventually cross the inflection point of biofuel costs.

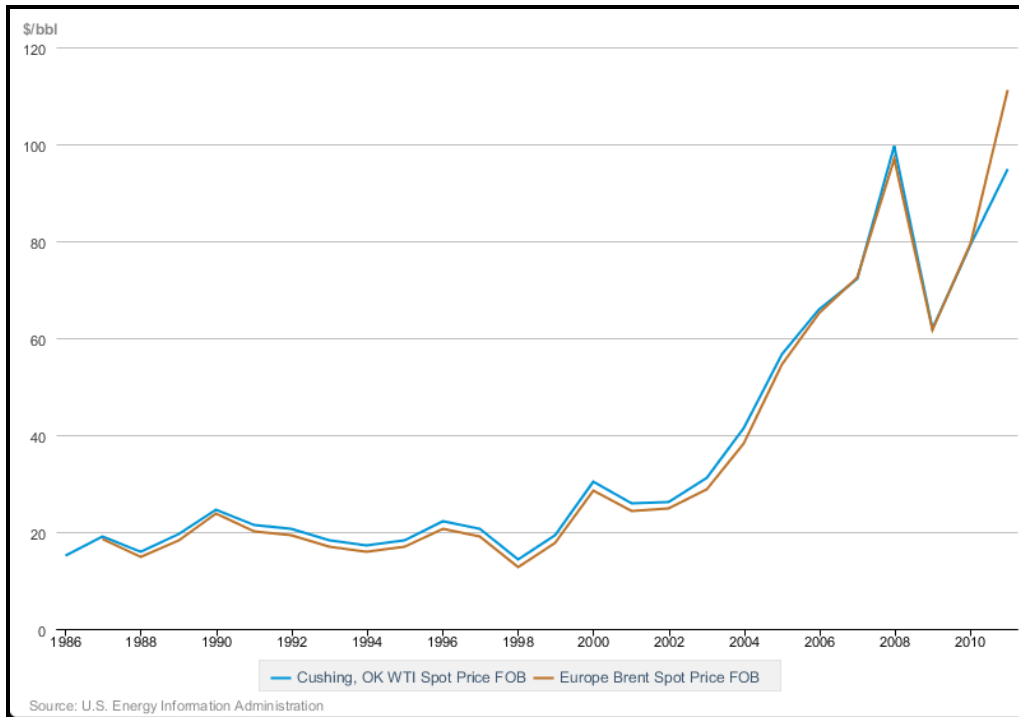

Figure 2. Oil spot prices in \$/bbl since 1986 (From U.S. Energy Information Administration 2013).

As a result, the United States Navy and Air Force have both investigated the harvesting of plants for fuel (Custer 2007). While many plants can be converted into fuel, algae have shown particular promise as renewable feedstocks for biofuel production. This is due to their abundance, rapid and easy growth, and high oil content. According to Dr. Julie Zimmerman of the Yale School of Engineering and Applied Sciences and the Yale School of Forestry and Environmental Studies, algae offer many advantages for biofuel production compared to options such as corn and sugar cane, since algae do not compete with food demand, grow on marginal land, and produce more oil per acre of crop (Ky 2011).

There are also environmental benefits of using algae as a biofuel source. Dr. Zimmerman noted that since algae decompose easily in landfills, the nutrients produced by anaerobic digestion of biomass can be recycled directly back to the first step of cultivation (Ky 2011). Furthermore, because algae grow quickly and easily, the repeating feedback loop of renewable energy could make algal biodiesel production partially self-sustainable.

### **3. Biofuel Efforts and Challenges**

A major factor driving the U.S. military's interest in finding alternative sources of fuel is cost growth of crude oil. In 2009, the price of a barrel of oil was approximately \$62 (Saphire Energy 2009). In comparison, market data compiled by Bloomberg L.P. indicates that crude oil was being traded at close to \$97 per barrel during the first quarter of 2013 (Bloomberg 2013). This escalation does not include the ancillary costs the U.S. military faces as oil prices increase. In fact, it is estimated that the U.S. military pays a \$31 million penalty in ancillary fuel costs for every \$1 increase in the cost of a barrel of oil (Abbotts 2012). To combat rising oil costs, Navy Secretary Mabus outlined a plan for the development and procurement of a biofuel alternative as a replacement for petroleum-based fuel. Navy Fuels Team Lead, Rick Kamin, further outlined that any new biofuel source would need to meet current performance specifications and be able to mix successfully with current petroleum fuel (Abbotts 2012).

The Naval Air Station (NAS) Patuxent River in Maryland began testing small amounts of biofuels in 2008. In 2009, the Defense Logistics Agency (DLA) awarded a contract with Sustainable Oils, Inc. to provide almost 600,000 gallons of biofuel (Abbotts 2012). The Sustainable Oils test fuel was created from the oil of a mustard seed called camelina. Camelina-based JP-5 was blended with petroleum-based JP-5 in a 1:1 ratio and was tested for performance degradation during 16 test flights on an F/A-18 Green Hornet in 2010. Following the successful Green Hornet testing, an MH-60S Seahawk helicopter completed flight testing with the same 50/50 blend. In 2011, the Seahawk flew again, but this time with an algae-based fuel. Finally, in August 2011, the MV-22 Osprey became the first Marine Corps aircraft to fly with a biofuel blend. These successful test events resulted in the conclusion that oils produced from different renewable feed sources could be used interchangeably with traditional petroleum-based fuels without the need for costly regression test and evaluation (Abbotts 2012).

Naval testing of algae-based fuels transitioned to sea operations, as well. In July 2010, a biofuel powered Rigid-Hull Inflatable Boat (RHIB) was tested side-by-side with an identical craft powered by petroleum. This biofuel powered RHIB achieved a top speed of 44.5 knots, or approximately 52 miles per hour (Abbotts 2012). A Yard Patrol

(YP) boat became the next marine vehicle to successfully operate using a biofuel blend called algae-F-76. Finally, in December 2011, the Navy tested an algae-petroleum fuel blend on a Landing Craft-Air Cushioned (LCAC) hovercraft in Panama City, Florida. The LCAC achieved a top speed of 50 knots, approximately 58 miles per hour, setting a record as the fastest U.S. Navy waterborne vehicle using an alternative fuel blend (Abbotts 2012). There is, however, a noticeable performance drop from using biofuel. For example, the LCAC using conventional fuel can reach up to 70 knots (Storms 2011). The aforementioned flight and sea tests combined with federal energy mandates and clean energy initiatives, are paving the way for future use of biofuel-powered vehicles in naval operations (Abbotts 2012).

## **B. DEFINING THE PROBLEM**

### **1. Problem Definition**

The United States Pacific Command (USPACOM) in Hawaii uses approximately 130 million gallons of fuel for aviation each year (Simonpietri 2011, p.16). This fuel arrives as crude oil and refined fuel from the United States (and other countries) via tankers and is delivered to refineries located in Hawaii. In 2007, it was reported that 24% of the refined fuel is imported from CONUS (Continental United States) with all other crude oil and refined product coming from other countries (Simonpietri, Ashworth, and Aden 2012). Delivery of the fuel can be impeded by both weather and potential hostile naval action. In order to reduce these threats and ensure continued operations, USPACOM expressed an interest in locally producing 25%, or 32 million gallons, of its required aviation fuel in Hawaii each year (Simonpietri 2011, p.14). Consequently, USPACOM identified biofuel from algae as a leading candidate for potential fuels to reduce the existing reliance on crude oil. In a briefing given by CDR Joelle Simonpietri of the USPACOM Energy Office (USPACOM J81), an Enterprise Model developed by Green Initiatives for Fuel Transition Pacific (GIFTPAC) identified a critical gap in the Grow, Harvest and Pre-process elements, as shown in Figure 3. GIFTPAC is a working group with the goal of offsetting petroleum-based fuel supply in Hawaii with non-fossil fuel (Simonpietri 2011).

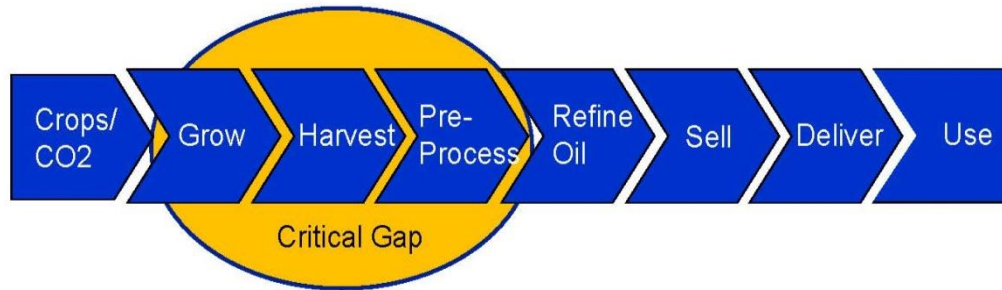

Figure 3. Enterprise model for biofuel production and use, showing critical gap in the process (From Simonpietri 2011, p.17).

The production of sufficient biomass to meet the USPACOM production goal of 32 million gallons of biofuel, with a target cost of less than \$3 U.S. per gallon, poses significant challenges and concerns related to:

- land availability,
- natural resources required,
- energy consumption,
- environmental impact, and
- the economic impact on the state of Hawaii.

## 2. Scope

The team developed the following problem statement to capture project scope and guide project efforts throughout the Capstone process:

*USPACOM lacks a method to locally produce a quantity of biofuel equivalent to 25% of its annual naval aviation fuel consumption. There is currently only limited understanding of the feasibility of developing a commercially viable quantity of biofuel to meet this goal within the Hawaiian Islands.*

The desire to locally produce biofuel stemmed from several issues including potential threats to supply, economic development, and the environment. While algal biofuel has been widely studied in both the military and civilian environments, there have been no previous efforts to develop a complete algal biofuel system located in Hawaii that is capable of meeting the biofuel output requirements. The processes and methods for

studying the feasibility of a potential solution to the problem, called the Hawaii Naval Aviation Biofuel System (HNAABS), are discussed throughout this paper.

There were several assumptions made during the project development stage which shaped the original scope for the HNAABS design and evolved into necessary constraints. The key assumptions are as follows:

- The target price of \$3/gal was assumed to be for biofuel only and does not apply to a biofuel-petroleum fuel blend. The direct cost associated with biofuel was assumed to be independent of the fuel blend and does not affect the cost of petroleum-based fuels.
- For production estimation purposes, the HNAABS design was assumed to operate continuously 24 hours a day, 7 days a week.

Cost estimation of the HNAABS design was of particular importance for this capstone project. Key areas of interest included 1) the cost of building the necessary infrastructure or utilizing existing infrastructures, and 2) the Free On-Board cost per gallon produced. Detailed cost estimates are provided in Section V of this report.

There was also a strong desire to determine what effects algal biofuel may have on the tactics and operations of naval aviation. This portion of the overall biofuel problem was de-scoped from the HNAABS effort due to time and manpower limitations. However, according to an article in the Spring 2012 issue of Currents Magazine, an F/A-18 Green Hornet aircraft operating with a 50-50 blend of biofuel and petroleum performed "as expected, through its full flight envelope with no degradation of capability" (Abbotts 2012). Likewise, the rigid-hull inflatable boat testing described in a previous Section I.A showed that "there were no differences in the ship's performance, even at full power" (Abbotts 2012).

The Capstone research team chose to focus its analysis of the HNAABS design primarily on the cultivation and refinement systems, as shown in Figure 4. These systems will be referred to as the HNAABS Cultivation and HNAABS Refinement systems throughout this document. The Cultivation system design focused on analysis of the Growth, Harvest, Dewatering, and Oil Extraction subsystems while the Refinement system design was evaluated through a business case analysis comparing the option of building a new oil refinery to the options of retrofitting an existing petroleum refinery or

using a combination of the two options. Cultivation and Refinement system results and recommendations are provided in Section III of this document.

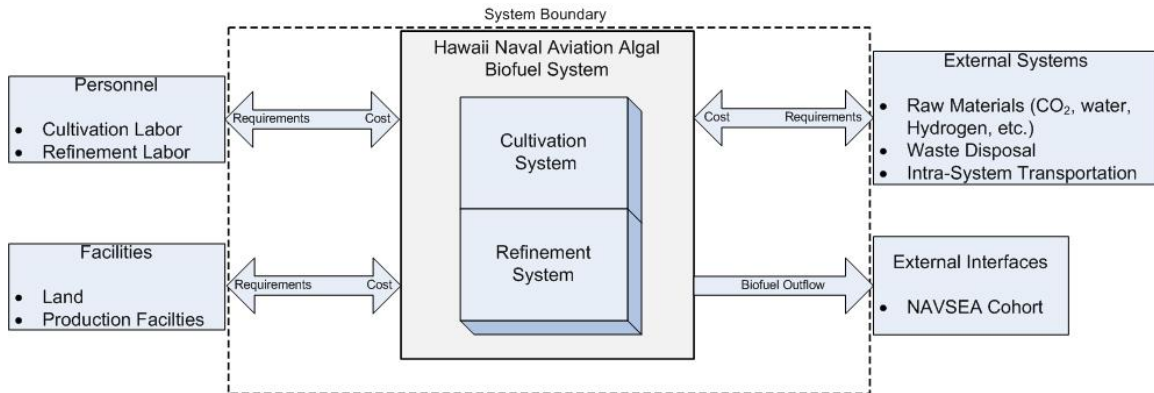

Figure 4. Proposed HNAABS system of systems diagram showing key interfaces and boundaries.

The team decided to treat the HNAABS design as a System of Systems (SOS). The team did not perform a full DOTMPLF analysis; however, the HNAABS Project Team did analyze the system problem in terms of the DOTMPLF categories, specifically the organization, materiel solution, personnel, and facilities aspects of the process. DOTMPLF is used by the Department of Defense as a mnemonic device for “doctrine, organization, training, materiel, leadership and education, personnel and facilities.” (Defense Acquisition University 2012).

The Cultivation and Refinement systems were designed as materiel solutions. As a result, personnel, facilities, and the external systems identified outside the system boundary in Figure 4, were not included in the scope of this system design effort due to time constraints. While these items were not considered part of the system design, they were not omitted from the analysis altogether. The HNAABS Project Team accounted for the external system boundary items by:

- estimating land and resource usage,
- developing associated requirements,
- considering these factors while analyzing Cultivation and Refinement system alternatives, and

- including associated costs in the estimated Free On-Board cost per gallon of bio-kerosene

The detailed aspects of these external items were not considered. For example, the personnel assessment would have included determining not only how many workers would be needed for HNAABS, but also the qualifications and skills required to run each subsystem. The facilities assessment would have required a full design of both the Cultivation and Refinement facilities, complete architectural interface design, and selection of a proper location within the Hawaiian Islands. The external systems box in Figure 4 included items such as raw materials, waste disposal, and intra-system transportation. These systems were de-scoped from the HNAABS design process in an effort to limit the project scope to a level commensurate with the nine-month timeframe.

### C. PROJECT TEAM

#### 1. Project Tasking

The HNAABS Project Team was broken into five distinct teams charged with exploring the feasibility of a design to meet USPACOM biofuel production goals in Hawaii. The teams each focused on a particular area of research and were named the Cultivation, Refinement, Environmental, Cost, and Requirements Teams to reflect this. Figure 5 shows the HNAAB Project Team structure.

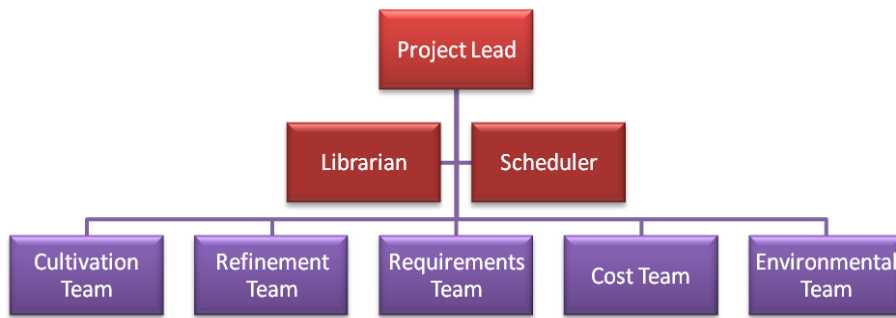

Figure 5. HNAABS team organization breakdown showing the top level IPT structure.

The Cultivation team was responsible for identifying the process and system components addressing:

- the growth and harvesting of algae,
- the extraction of algal oil from the harvested algae

Because the Cultivation system comprised such a large portion of the HNAABS design effort, the Cultivation team was divided to form four Integrated Product Teams (IPTs) associated with each of the cultivation sub-functions. The IPTs each contained at least one member from each of the five main research areas to ensure adequate subject matter expertise throughout the analysis process. The four Cultivation IPTs that were created were called:

- the Growth team,
- the Harvest team,
- the Dewatering team, and
- the Oil Extraction team

The Refinement team was responsible for identifying the process and system components to be used in refining the extracted algal oil into bio-kerosene.

The Environmental team was responsible for determining the laws and regulations that would constrain the HNAABS design as well as providing environmental oversight to the overall HNAABS system design. This oversight included issues such as determining water sources and methods for waste treatment and disposal.

The Cost team provided oversight for the cost feasibility analysis of the HNAABS design. They were responsible for developing the overall HNAABS design cost estimation approach as well as the Free On-Board cost of biofuel per gallon.

Finally, the Requirements team was responsible for developing the following documentation:

- the project Integrated Master Schedule (IMS),
- the HNAABS CORE® model,
- the Program Management Plan (PMP),
- the Risk Management Plan (RMP),

- the HNAABS risk oversight and mitigation plan and overall final risk assessment,
- the HNAABS performance specification, and
- the HNAABS system level requirements

The goal of the team management process was to build a strong hierarchy. This allowed a smaller number of people to manage the entire group, thereby enabling more engineers to remain directly focused on the project, rather than efforts in support of the project. This project leadership group (COR3), addressed the when (Scheduler), what (Librarian), and how (Project Leader) questions that came up during the course of the capstone project. Due to the number of moving parts associated with such a large team, the project group was decomposed into the five lower level Project Teams described previously. Having a leader in each team allowed the project leadership group to manage five aspects of the project, rather than the efforts of twenty six individual people.

Meetings were held weekly with the team leads to monitor the progress of each team and to identify missing data elements between groups. Team leads were empowered to manage their organization, allowing for maximum flexibility and preventing micromanagement. This left the COR3 team free to manage the group interfaces, without being burdened by internal group decisions.

The end result of this process produced five, relatively independent papers, which were combined into a full Capstone team thesis (four sections plus the appendices). Although this created an integration burden for the entire Project Team, this integration method closely follows the large program systems engineering methods for design integration and qualification. This structure drove the need for the project Librarian to manage the physical data interfaces such as content format and location. This increase in modularity allowed all the teams to work in a more parallel structure, which resulted in an increase of the possible scope of this project and a decrease in project cycle time.

## **2. Association with NAVSEA Capstone**

This Capstone project is part of a systematic approach to identify a solution to supplying 25% of Hawaiian military aviation fuel needs through the use of algal biofuels.

While the five Project Teams described in the previous section focused on project requirements, algae cultivation, green crude oil refinement, and the cost and environmental impacts associated with these processes, a second Naval Postgraduate School (NPS) capstone team was responsible for another part of the problem. A cohort from the Naval Sea Systems Command (NAVSEA) attempted to develop a solution to the problem of transporting the theoretical refined bio-kerosene output from the HNAABS design, mixing the biofuel with petroleum-based aviation fuels and additives, storing the resulting biofuel blend, and distributing the algae biofuel for use in Hawaii.

Close coordination between the two capstone teams resulted in a set of system boundaries for each cohort. It was determined that the NAVAIR cohort would:

- investigate the feasibility of cultivating enough algae within the Hawaiian islands to provide an adequate supply of green crude oil to meet the stated annual aviation fuel needs, and
- determine the feasibility of refining green crude oil into a product that can be blended with petroleum-based aviation fuel to produce biofuel.

This feasibility assessment incorporated all facets of cultivation and refinement up to the production of biofuel, including an examination of the land and resources available to support biofuel production and the capital and continuous costs associated with the cultivation and refinement infrastructure.

The NAVSEA cohort was tasked with establishing a system to blend bio-kerosene with petroleum-based aviation fuel and developing a methodology to distribute the blended product to the point of use by the Department of Defense in Hawaii. The findings and conclusions generated by the first group, NAVAIR cohort 311-113A, are described in this paper.

## **D. SYSTEMS ENGINEERING PROCESS**

### **1. Organization**

The Systems Engineering Process used during the HNAABS project is a modification of the International Council of Systems Engineers (INCOSE) process model. The modified process, shown in Figure 6, enabled the Project Teams to apply systems engineering analysis to define the stakeholder needs, utilize dedicated resources

and tools to construct a System of Systems model, and ultimately present a recommendation for an HNAABS design solution at the end of the allotted capstone project schedule. Figure 6 also depicts the tailored HNAABS project in three basic sections aligned to the NPS academic calendar: Early-Preparation Phase, Research Phase, and Development Phase.

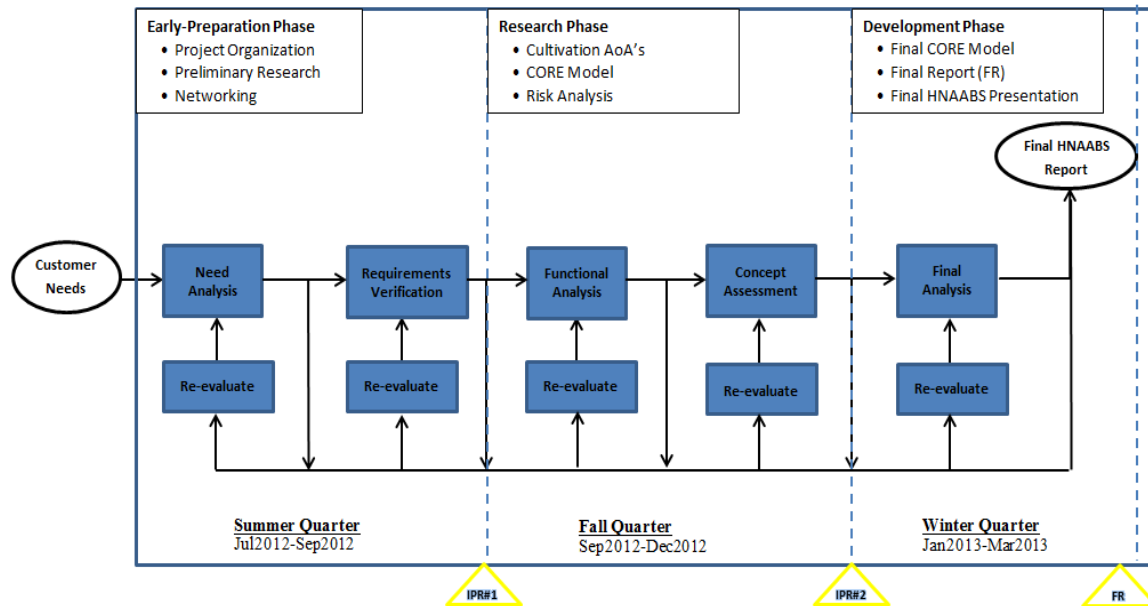

Figure 6. HNAABS systems engineering/project cycle model.

The Early-Preparation Phase (Summer Quarter) consisted of building the team organization, performing early research, and engaging in networking activities and open discussions with various stakeholders and capstone project advisors. During this initial research phase, it was determined that a face-to-face meeting with USPACOM and other Hawaii stakeholders would be beneficial to fully understand the customer needs. The sponsor and stakeholder needs were used to identify early-design requirements, a system Concept of Operations (CONOPS), and prioritization of the SOS capabilities. Additionally, risks identified by initial research and internal team discussion were captured in a formal Risk Management Plan (RMP). This facilitated early identification of team risk and assigned ownership for each risk. To support the given schedule of the project, an Integrated Master Schedule (IMS) was created to track and monitor project

deliverables. To capture the system scope and essential technical activities, a Program Management Plan (PMP, Appendix B) and Performance Specification (Appendix A) were created to provide a methodology for completing the HNAABS feasibility analysis.

The Research Phase (Fall Quarter) comprised the majority of the system functional analysis and concept assessment. Following the establishment of the requirements baseline and derived CONOPS, functional analysis was performed in parallel with ongoing stakeholder queries and technical research. Vitech Corporation's CORE<sup>®</sup> 8.0 Modeling Based Systems Engineering (MBSE) tool was used to capture the identified top level functions and functional decomposition. The CORE<sup>®</sup> software provides a method to display the Input, Controls, Outputs, and Mechanisms/Information Definition Exchange Format (ICOM/IDEF) models, hierarchical structure, Functional Flow Block Diagrams (FFBDs), and other system architecture diagrams in a visual manner. Initial Cultivation and Refinement System architectures were developed to define generic system functions and capture design constraints and risks. As the system alternatives were analyzed, the CORE<sup>®</sup> models were updated to reflect the specific details associated with the recommended system designs. The major inputs used in re-evaluating the system architecture came from assessment of the Cultivation and Refinement system Analysis of Alternatives (AoA) reports. These inputs were used to:

- properly define and support the selection of the functions to satisfy the requirements,
- capture the system design constraints, including risks which might affect system operations, and
- identify a list of benefits/improvements to the system functions.

The final Deployment Phase (Winter Quarter) consisted of in-depth analysis of results obtained during the Research Phase, cost analyses, continuation of risk management efforts, compilation of a final CORE<sup>®</sup> model, release of a final report documenting the recommendations for the preferred HNAABS solution, and presentation of findings to all stakeholders.

## **2. Cultivation Component**

Several algae cultivation alternatives were identified for potential use in the HNAABS design. An AoA process was used to determine the optimal cultivation approach. The analysis included evaluation of the comparative cost, performance, and environmental impact/risk of each alternative. Furthermore, the analysis was used to determine the appropriate subsystems to integrate within the entire algae Cultivation system.

The HNAABS Project Team used a form of Quality Function Deployment (QFD) to assess the merits of each alternative. QFD is a “method to transform user demands into design quality, to deploy the functions forming quality, and to deploy methods for achieving the design quality into subsystems and component parts, and ultimately to specific elements of the manufacturing process” (Akao 1994). Using QFD, the alternatives were compared with each other using an established set of criteria derived from expected stakeholder priorities. In the end, the photobioreactor growth process and single-step oil extraction™ process were chosen as the proposed cultivation solution. Details regarding the Cultivation AoA process are described in detail in Section II.C.1 of this report.

## **3. Refinement Component**

Several business scenarios were analyzed for the HNAABS Refinement system. These scenarios included retrofitting an existing refinery to accommodate biofuel processing, building a new refinery, and a hybrid solution combining the other two options. Ultimately, the hybrid alternative was chosen as it was assessed to be the lowest risk and most cost effective alternative for implementing a green crude refinery in Hawaii. The cost comparison between the retrofit and hybrid alternatives was negligible; however, both were cheaper than building a new refinery. The hybrid alternative has the flexibility of producing petroleum fuels in parallel with HNAABS bio-kerosene whereas the retro fitting option only allows for the production of bio-kerosene and would be constrained to the existing petroleum refinery infrastructure. Another consequence of retrofitting a petroleum refinery into a green crude refinery is the potential for lower

reliability in the system components due to their incompatibility with the green crude composition. The primary drawback of the new refinery alternative is the increased amount of indirect costs due to the requirement to construct the entire external refinery, support infrastructure, and interfaces to support the facility. A hybrid system offers the optimal cost solution with lower risks related to reliability, as well as increased system capabilities. Detailed Refinement system analysis can be found in the Section III.C of this report.

#### **E. PROJECT DELIVERABLES**

To address the Capstone problem statement, the HNAABS Project Team developed a repeatable process to assess potential alternatives capable of furnishing 25% of Hawaiian naval aviation fuel needs. Additionally, the team used this design process to determine a recommended problem solution with associated feasibility and cost assessments. While stakeholders and subject matter experts may disagree with the scoring assessments used by the HNAABS Project Team, the design process can be easily modified with alternate data to arrive at different conclusions.

In addition to these two major products, the following project deliverables support the conclusions and recommendations outlined in this paper:

- Functional model of the complete SOS
- Complete cost analysis of the SOS:
- Free On-Board cost of biofuel production.
- Cost of necessary infrastructure
- Environmental impact of the SOS.
- Energy and economic impact on the state of Hawaii.
- CORE<sup>®</sup> models and other re-usable analysis tools.

## **II. PROBLEM FORMULATION**

### **A. NEEDS ANALYSIS**

The first HNAABS In-Progress Review (IPR-1), conducted on 27 September, 2012, was used to formalize the results of the need analysis performed by the HNAABS Team. IPR-1 attendance included a USPACOM representative, a NAVSEA cohort representative, and the entire HNAABS Team to include advisers. Stakeholder analysis as well as needs & constraints, derived from IPR-1, are discussed in the following sections.

#### **1. Stakeholder Analysis**

Based on the results of IPR-1, the HNAABS Team identified the following organizations as stakeholders:

- Department of Defense. Responsible for supervising and the protection of U.S. national security and of all U.S. Armed Forces (U.S. Department of Defense 2013). A feasible and affordable algal-based biofuel production system in Hawaii could reduce DoD fuel distribution and management costs thereby reducing U.S. Government defense costs as a whole while providing a partial local supply not dependent upon sea lines of communication.
- USPACOM. Based in Honolulu, Hawaii, USPACOM protects and defends the United States of America with other U.S. Government agencies, its territories, allies and partners, and its assets from hostile threats in the Pacific and Asian regions. USPACOM is the main sponsor for HNAABS (U.S. Pacific Command 2013). A feasible and affordable algal-based biofuel production system in Hawaii could reduce USPACOM costs on fuel distribution and management thereby reducing U.S. Government defense costs as a whole while providing a partial local supply not dependent upon sea lines of communication.
- USPACOM Fuels Team. Responsible for fuel supply and consumption by USPACOM controlled forces in the Pacific region, an area that covers 105 million square miles (U.S. Pacific Command 2013). A feasible and affordable algal-based biofuel production system in Hawaii could reduce the fuel supply and distribution costs thereby reducing USPACOM and U.S. Government defense costs as a whole.
- Office of the Chief of Naval Operations (OPNAV) Energy & Environmental Readiness Division (N45). Develops and assesses policies

and guidance for energy and environment concerning Naval operations on land and sea worldwide (United States Navy 2013). A feasible and affordable algal-based biofuel production system in Hawaii reduces or eliminates the environmental hazard caused by the transportation of fuel to Hawaii from the Continental United States (CONUS). As stated earlier, all crude oil and refined fuel products are imported either from CONUS (24% of all imported refined fuel) or other countries. This potential hazard reduction or elimination would reduce fuel supply and distribution costs, not to mention minimize the risk of environmental suits against the government due to a hazardous material (HAZMAT) mishap, all of which would reduce U.S. Government defense costs as a whole.

- Environmental Protection Stakeholders (Federal and the State of Hawaii). Concerned with the impacts of an algal-based biofuel production system on the local Hawaii environment, to include business, agriculture and health. Similar to the previous stakeholder, a feasible and affordable algal-based biofuel production system in Hawaii reduces or eliminates the environmental hazard caused by the transportation of fuel to Hawaii from the CONUS. This potential hazard reduction or elimination would mean a reduction of U.S. Government defense costs as a whole. Hawaii Environmental Protection Stakeholders include:
  - United States Environmental Protection Agency. Writes and enforces regulations and laws passed by Congress concerning human health and protecting the environment (U.S. Environmental Protection Agency 2013).
  - United States Department of Energy. Responsible for the U.S. energy, environmental, and nuclear policies through regulation and development (U.S. Department of Energy 2013).
  - Hawaii State Department of Business, Economic Development & Tourism. Promotes job growth, businesses, and projects concerning energy usage in the State of Hawaii (State of Hawaii 2009).
  - Hawaii State Energy Office. Regulates energy usage and provides guidance for businesses and the public concerning energy related issues (State of Hawaii, About Hawaii Energy, 2013).
  - The Hawaii Department of Agriculture. “Lead the State’s effort to maintain the agricultural sector of Hawaii’s economy, including livestock production, forestry, crops and aquaculture, in a strong and competitive condition by providing policies, services, loans, subsidies, environmental protection, land and water, operations, facilities, advice, coordination, and information so as to achieve appropriate rates of growth, high levels of employment, reasonable

returns on investment, and steady gains in real personal income” (State of Hawaii 2013).

- The Hawaii Department of Health. State agency whose mission is “to protect and improve the health and environment for all people in Hawai`i” (State of Hawaii 2013).
- Refiners. Refineries are responsible for converting algal oil to bio-kerosene. In order to minimize costs, an algal-based biofuel production system in Hawaii could leverage existing refinery infrastructure, which would minimize the initial investment costs of the system thereby reducing U.S. Government costs as a whole. Some of the local refiners who could potentially upgrade their facilities to produce algal-based biofuel include Tesoro, Chevron, and Pacific Biodiesel.
- Farmers. Local growers such as Hawaiian Commercial & Sugar Company are looking for new ways to stay competitive in the world market by finding new potential agricultural crops to sell (Hashimoto 2012). Using local growers in Hawaii to supply an algal-based biofuel production system would minimize the operational costs of biofuel production facilities as well as introduce more money into the Hawaiian local economy.
- Land owners. Are concerned in land usage and regulation. A feasible and affordable algal-based biofuel production system in Hawaii could require a massive amount of land. Land owners in Hawaii will be concerned with the usage of any new land developments and their impact on their own properties. The top 10 land owners in Hawaii are: State of Hawaii (1.54 million acres), U.S. Government (531,000 acres), Bishop’s Trust (363,000 acres), Alexander & Baldwin (113,000 acres), Parker Ranch (107,000 acres), Larry Ellison (Most of 141 square miles of Lanai – unknown acreage), Molokai Ranch (58,000 acres), Robinson Family (51,000 and 46,000 acres), Grove Farm (59,000 acres) (J. Cooper 2012).
- Algae developers. Are interested in meeting the State of Hawaii’s needs in developing a locally grown alternative to fuel consumption. An algal-based biofuel production system in Hawaii could leverage local algae developers in order to supply its system with the required algae type and amount. This, in turn, could reduce the operational costs of the biofuel production system thereby reducing USPACOM and U.S. Government defense costs as a whole. Hawaii algae developers include Cellana, Phycal, General Atomics, and Hawaii BioEnergy.

- Seed or crop developers. Are interested in market supply and demand for algae developers. Similar to the algae developer stakeholder analysis discussion, an algal-based biofuel production system in Hawaii could leverage local seed or crop developers in order to supply its system with the required algae type and amount. This, in turn, could reduce the operational costs of the biofuel production system thereby reducing USPACOM and U.S. Government defense costs as a whole. Hawaii seed and crop developers include Kuehnle AgroSystems (Hawaii Renewable Energy Development Venture 2013).
- Hawaii Utilities/Government Utility Management. Have a direct interest and impact for future supply and demand and how those utilities are managed. A feasible and affordable algal-based biofuel production system in Hawaii would put additional strain on existing Hawaiian utility infrastructures. The biofuel production system must minimize potential infrastructure issues by coordinating and ensuring that the utility resource requirements do not exceed current capacities. Hawaii Utility and Utility Management entities include:
  - Power. Electric power is limited on the Hawaiian Islands. Some Hawaii power companies are interested in having a locally grown renewable source of fuel. These companies include Hawaiian Electric Company (HECO), Hawaiian Electric Light Company (HELCO), Kauai Independent Utility Cooperative (KIUC), and Maui Electric Company (MECO).
  - Water. Hawaii water usage is monitored by the Hawaii Water Board Commission (State of Hawaii 1997) and the Water Resource Research Center (University of Hawai'i 2013). The local utility companies have a direct interest in water usage and impacts from growing algae crops. These companies include the Board of Water Supply (City and County of Honolulu 2013) and Hawaii Water Service Company, (California Water Service Group 2013)
  - Fuel Consumption. Some companies directly supply fuel to consumer consumption that would be interested in a locally grown Hawaiian resource. These companies include Aloha Petroleum (Aloha Petroleum Ltd. 2013), Hawaiian Petroleum, and Maui Petroleum (Hawaii Petroleum 2013).
  - Waste Disposal. Various companies and government departments are used to monitor the waste disposal of the Hawaiian Islands, including the Department of Environmental Services (Honolulu Department of Environmental Services 2013), County of Hawai'i Department of Environmental Management (County of Hawai'i Department of Environmental Management 2013), Waste

Management (Waste Management 2007), and Office of Solid Waste Management (State of Hawaii 2013).

- Hawaiian Natural Energy Institute. “The Institute performs research, conducts testing and evaluation, and manages public-private partnerships across a broad range of renewable and enabling technologies to reduce the State of Hawaii's dependence on fossil fuel” (University of Hawai'i 2013). An algal-based biofuel production system could leverage the institute's knowledge base as well as technological expertise in developing and refining production processes.
- Ranchers. Local ranchers can be directly impacted by algae producing crops with a new potential food supplement of biomass as an addition to the grass fed to cattle. Algae crops could also pose impacts to grazing areas if new agricultural zones are used for algae growth. These local ranchers include Daleico Ranch-Ka'u, Ernest DeLuz Ranch-Hamakua, Kahua Ranch-Kohala, Kealia Ranch – South Kona, Kukaiau Ranch – Hamajua, Kukuipahu Ranch – North Kohala, Palani Ranch – North Kona, Parker Ranch - Waimea, RJ Ranch – Hamaku, and Triple D Ranch – Hamakua (Taste of the Hawaiian Range 2013).
- NAVSEA Cohort. Responsible for designing a system to transfer biofuel from refineries to the aviation fuel tanks.

## **2. Needs and Constraints**

Based on the problem definition and capability gaps described by GIFTPAC stakeholders, a preliminary set of user needs was developed. These user needs were translated into top-level system requirements and separated into essential needs and secondary needs using key performance parameter (KPP) and key system attribute (KSA) terminology. The ability to produce 32 million gallons of bio-kerosene annually was considered a KPP. Producing the bio-kerosene at a cost of \$3 per gallon, on the other hand, was deemed a KSA since the aviation fuel supply requirements could ultimately be met without satisfying the cost requirement. In this scenario, subsequent evaluation would be needed to determine whether or not the environmental and sustainment advantages outweigh the cost penalty paid over traditional petroleum-based fuel.

The user needs were discussed at IPR-1 with USPACOM stakeholders to ensure concurrence that the Project Team had an adequate understanding of the problem and user expectations. The resulting list of user requirements and derived requirements that

were developed later are captured in the HNAABS performance specification in Appendix A.

In addition to the user needs and requirements, key system constraints were developed early in the process. Many of these constraints pertained to environmental rules and regulations, legal issues, and physical constraints associated with land usage. These constraints helped frame design decisions that were technically sound, legal, and environmentally feasible. The following list presents relevant issues that restricted the overall system design:

- Air Quality and Emissions
- Land Use
  - Agricultural Lands
  - Conservation Lands
  - Utilize existing infrastructure and byproducts in concert with recycling
- Water Quality and Quantity
  - Water Use
  - Wastewater Generation
- Ecosystem
  - Invasive Algae Species
  - Endangered Animal Species
- Federal Regulations
  - National Environmental Policy Act (NEPA)
  - Clean Air Act (CAA)
  - Pollution Prevention Act
  - Clean Water Act (CWA)
- State Regulations
  - Department of Health, Clean Air Branch
  - Department of Health, Clean Water Branch
  - Department of Health, Office of Solid and Hazardous Waste Branch
  - The Office of Environmental Quality

- Department of Land and Natural Resources
- Local Regulations
  - Land Use Ordinances
  - Building Permits
  - Industrial Wastewater Discharge Permits
  - Water Use Regulations
- Infrastructure Issues
  - Traffic Concerns
  - Energy Grid
  - Nutrient Resources

## **B. FUNCTIONAL ANALYSIS**

### **1. Functional Decomposition**

The HNAABS Team created a functional decomposition (hierarchy) diagram using a CORE<sup>®</sup> model to get further insight into the functional production of biofuel as depicted in Figure 7. The hierarchy diagram breaks down the production of biofuel into its various lower-level functions, from Tier 1 to Tier 3 functions. In order to accomplish the top level Produce Biofuel (1.0) function, three Tier 2 functions are required. These Tier 2 functions are comprised of: Produce Algal Oil (2.0), Transport Green Crude Oil (3.0), and Refine Algal Crude (4.0) functions. These Tier 2 functions were the main focus for the functional decomposition process.

The HNAABS Cultivation System, discussed in the previous section, is represented in the CORE<sup>®</sup> model by the Produce Algal Oil (2.0) function. This function was decomposed into four Tier 3 functions that include: Cultivate Algal Biostock (2.1), Extract Green Crude (2.2), Dewater Algal Biomass By-Product (2.3), and Store Biostock Harvest Products (2.4) functions. These four Tier 3 functions give greater insight into the functional composition of the Produce Algal Oil (2.0) function.

The stored algae biomass needs to be transported from the cultivation facility to the refinement facility. The Transport Green Crude Oil (3.0) function, depicted in Figure 7, was not decomposed any further than the 2nd tier level of the functional decomposition

process. The main focus was to look at the HNAABS Cultivation and Refinement functions to determine how to produce and refine algae into biofuel. The transportation processes between the cultivation and refinement facilities were de-scoped from the analysis.

Once the algae crude is transported to the refinement facility, the algal crude can be refined into a biofuel. The HNAABS Refinement System is represented in the CORE<sup>®</sup> model by the Refine Algal Crude (4.0) function. This function is decomposed into five Tier 3 functions. The Tier 3 functions comprise of: Receive Green Crude (4.1), Refine Green Crude (4.2), Manage By-products (4.3), Post-Process Refined Product (4.4), and Manage Refining Resources (4.5) functions. Further discussion on these functions will be continued in the following sections.

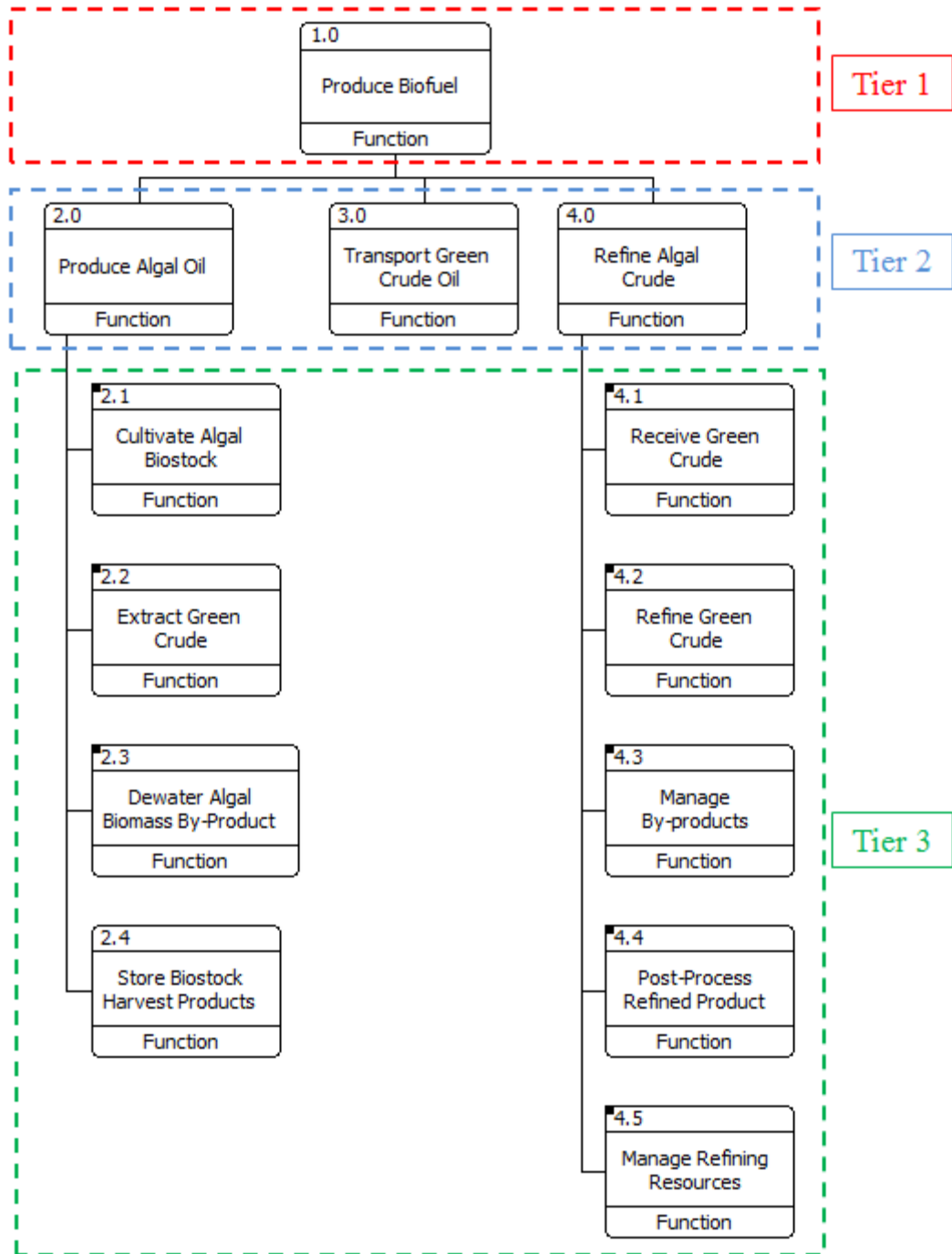

Figure 7. Produce Biofuel (1.0) functional decomposition (hierarchy diagram).

Note that the functions described in this Functional Analysis section represent the final solution put forth by the HNAABS Team; the advent of electroporation technology makes the extraction of algal oil before dewatering possible, which is why Extract Green

Crude (2.2) function comes before Dewater Algal Biomass By-Product (2.3) function. Further discussion on all of these functions, to include electroporation, will be continued in the following sections.

*a. Cultivation Functional Decomposition*

Breaking the HNAABS Cultivation functional area even further, the Tier 4 functions decompose the Tier 3 functions, depicted in Figure 8. The Tier 3 Cultivate Algal Biostock (2.1) function is decomposed further to include: Apply Algal Biostock (2.1.1), Regulate Algal Nutrients (2.1.2), Circulate Algal Biostock (2.1.3), Maintain Algal Growth Environment (2.1.4), Monitor Algal Biostock Growth (2.1.5), and Harvest Algal Biostock (2.1.6) functions.

The extraction of the algal oil can begin after the algae have been harvested. The Tier 3 Extract Green Crude (2.2) function is decomposed into four functional components that include: Store Cultivated Algal Biostock (2.2.1), Preprocess Algal Biostock (2.2.2), Process Algal Biostock (2.2.3), and Separate Processed Algal Biostock (2.2.4) functions.

As part of the Produce Biofuel (2.0) function, the algae must also go through a dewatering process. The Tier 3 Dewater Algal Biomass By-Products (2.3) function is decomposed into seven Tier 4 functions that include: Accelerate Flue Gases (2.3.1), Heat Flue Gases (2.3.2), Apply Algal Biomass By-product (2.3.3), Remove Algal By-product Moisture (2.3.4), Collect Airborne Dry Biomass By-product (2.3.5), Scrub Exhausted Cool Outside Air (2.3.6), and Exhaust Cool Outside Air (2.3.7) functions.

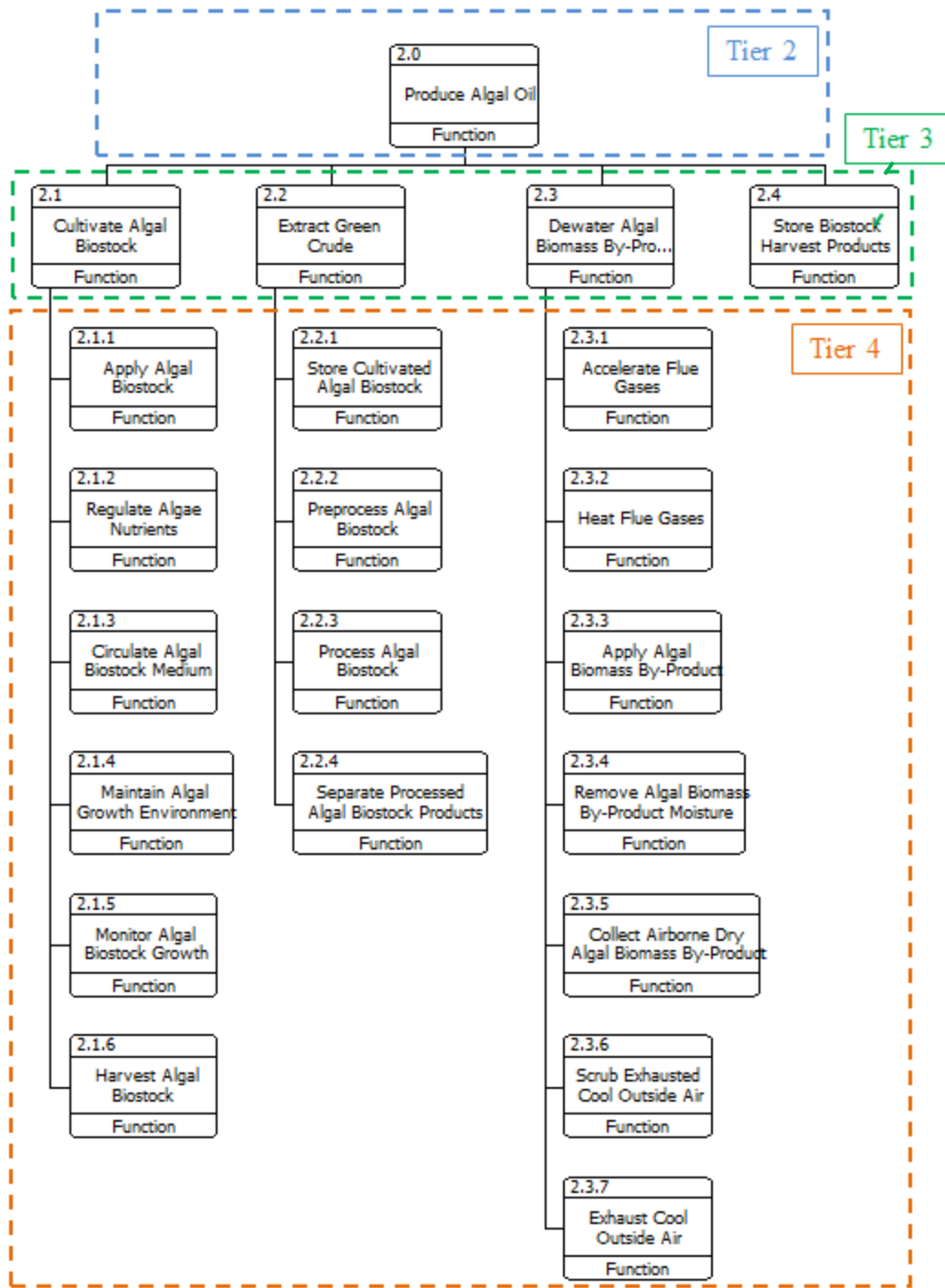

Figure 8. Produce Algal Oil (2.0) functional decomposition (hierarchy diagram).

***b. Refinement Functional Decomposition***

The HNAABS Refinement Tier 3 functions are decomposed further into the Tier 4 functions as depicted in Figure 9. Once the green crude is received, the Receive Green Crude (4.1) function is decomposed into its Tier 4 functions, which include: Perform Composition/Quality Check of Green Crude Oil (4.1.1), Store Green Crude (4.1.2), and Route Green Crude for Processing (4.1.3) functions.

The Refine Green Crude (4.2) function is decomposed into its Tier 4 functions, which include: Hydrotreat Green Crude (4.2.1), Hydrocrack (4.2.2), Fractional Distillation (4.2.3), and Reform Other Bio Fuels (4.2.4) function.

The Manage By-products (4.3) function is decomposed into Tier 4 functions, which include: Manage Liquid & Solid by-products (4.3.1), Manage Gaseous By-products (4.3.2), and Discharge Non-Recycle By-products From Facility (4.3.3) function.

The Post-Process Refined Product (4.4) is further decomposed into Tier 4 functions, which include: Perform Quality Check (4.4.1), Route to Storage Drums (4.4.2), and Store Refined Product (4.4.3) functions.

The Manage Refining Resources (4.5) function is decomposed into Tier 4 functions which include: Store Resources (4.5.1), Filter Resources (4.5.2), and Distribute Resources (4.5.3) functions.

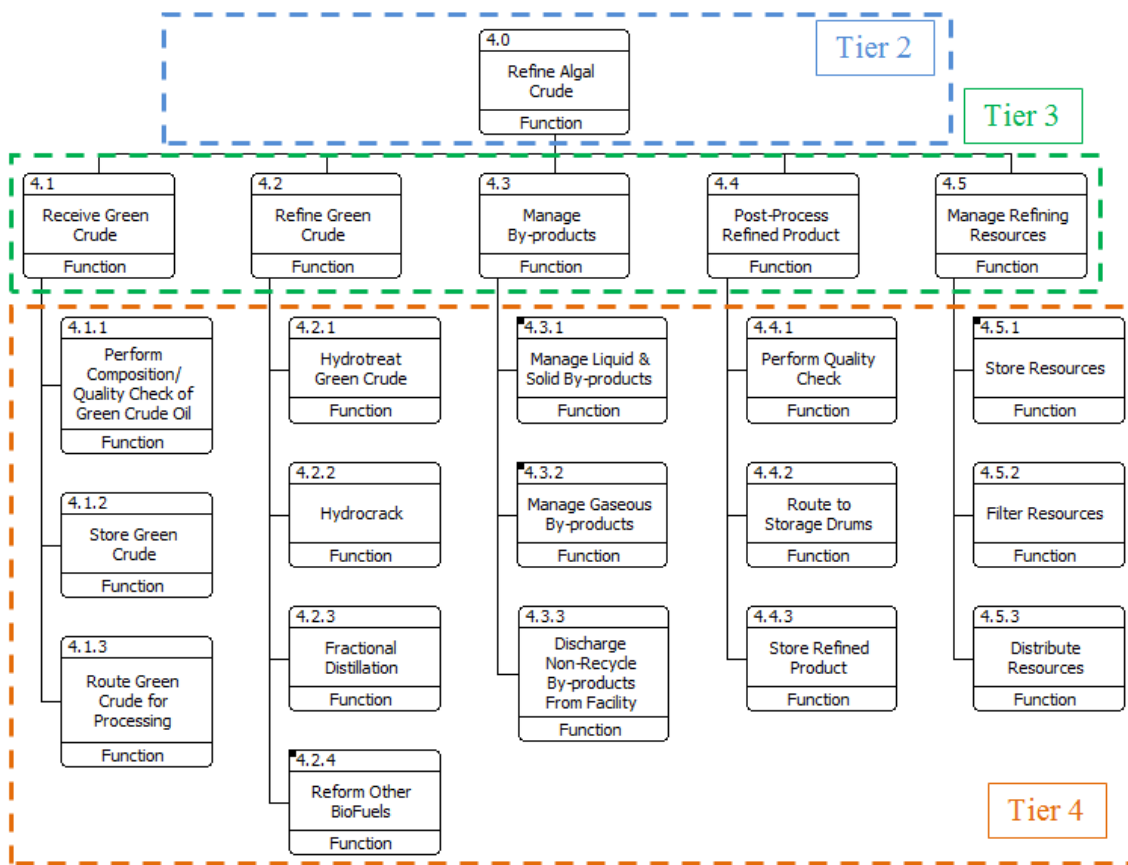

Figure 9. Refine Algal Crude (4.0) functional decomposition (hierarchy diagram).

## 2. HNAABS Tier 1 Functions

As part of the functional analysis process, the HNAABS Team also developed the system model using Integration Definition for Function Modeling (IDEF0) protocols in CORE<sup>®</sup> to describe the functions and their relationships in terms of inputs, outputs, controls, and mechanisms (Systems Management College 2001).

The IDEF0 modeling tool is used to understand the functional flow of the diagram to establish and define the relationships between other functions. Inputs are the arrows that flow into the left of the functional box and consist of various information and raw materials necessary for the function to perform its action upon. The outputs are the arrows that flow from the right of the functional box and consist of the product(s) of the function for use elsewhere. The controls are the arrows flowing into the top of the

functional box that serve as constraints of various types imposed upon the system. Lastly, the mechanisms are the arrows that flow into the bottom of the functional box and consist of resource requirements such as the physical implementation of the system in which the function resides (Systems Management College 2001).

Upon completion in documenting a function's inputs, outputs, controls, and mechanisms, lower-level sub-functions were created to further describe each higher function and better define the necessary components. This process is repeated until sufficient detail was achieved to merit implementation and usage of the model. Through the use of CORE<sup>®</sup>, advanced design concepts can be managed to include various levels of complexity.

As previously discussed, the first and highest tier is at the system level Produce Biofuel (1.0) and consists of three Tier 2 functions, which are: Produce Algal Oil (2.0), Transport Green Crude Oil (3.0), and Refine Algal Crude (4.0) functions. Figure 10 is the graphical representation using the IDEF0 protocol and represents the functional flow of the system from cultivation of the algal bio-stock with extraction of the green crude oil, refinement of the algal green crude oil into bio-kerosene, and includes the transportation between the two.

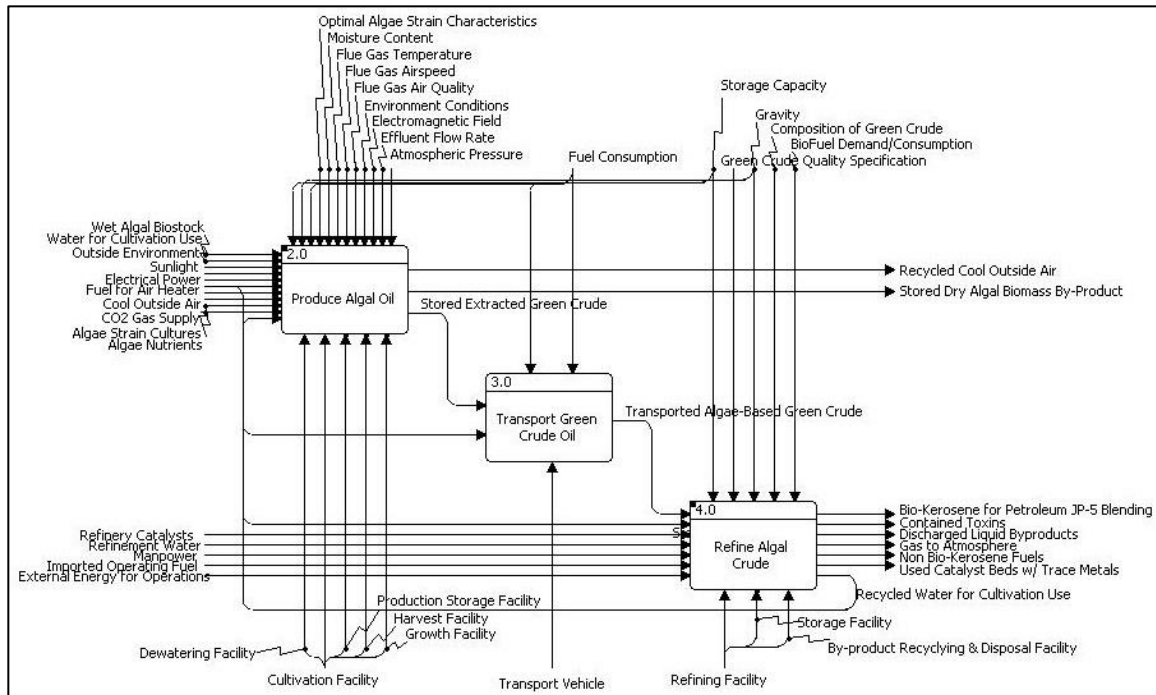

Figure 10. Produce Biofuel (1.0) functional analysis (IDEF0).

Application of the functional analysis process to the Cultivation phase of the system is shown in Figure 11. The figure is an example of both the functional decomposition and functional analysis process performed by the HNAABS Team on a given function at each subsequent tier. Specific discussions of each Tier 2 functions and their lower level functions will continue in the following sections. Figure 11, from left to right, drills down into the Produce Storage Algal Oil (2.0) function from within the Produce Biofuel (1.0) Tier 1 function. Then, the figure drills down into the Extract Green Crude (2.2) function from within the Produce Algal Oil (2.0) function Tier 2 function. Each of these tiers has its own hierarchy of functions, inputs, controls, outputs, and mechanisms that interface with other functions as depicted through the use of the directional arrows in Figure 11.

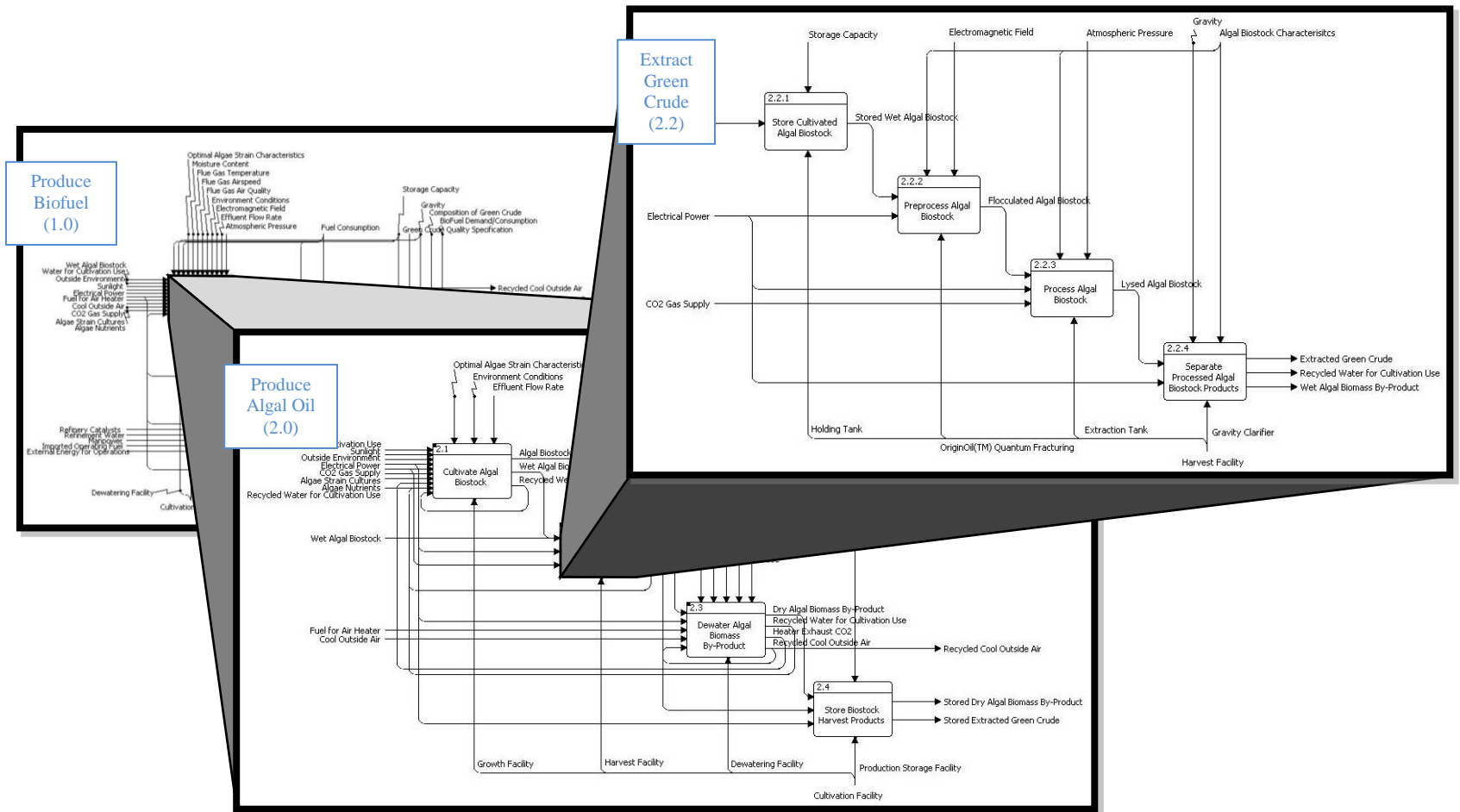

Figure 11. System functional decomposition example (IDEF0).

### **3. Cultivation Functions**

Upon decomposition of the Produce Algal Oil (2.0) Tier 2 function, the flow diagram is refined into four Tier 3 functional capabilities, which are: Cultivate Algal Biostock (2.1), Extract Green Crude (2.2), Dewater Algal Biomass By-Product (2.3), and Store Biostock Harvest Products (2.4) functions. These four functional nodes capture the main cultivation functions required to perform the overall capability of growing algal biostock and harvesting the algal green crude, and will be discussed in the sections to come. The IDEF0 chart produced by the CORE<sup>®</sup> analysis tool for this function is depicted in Figure 12.

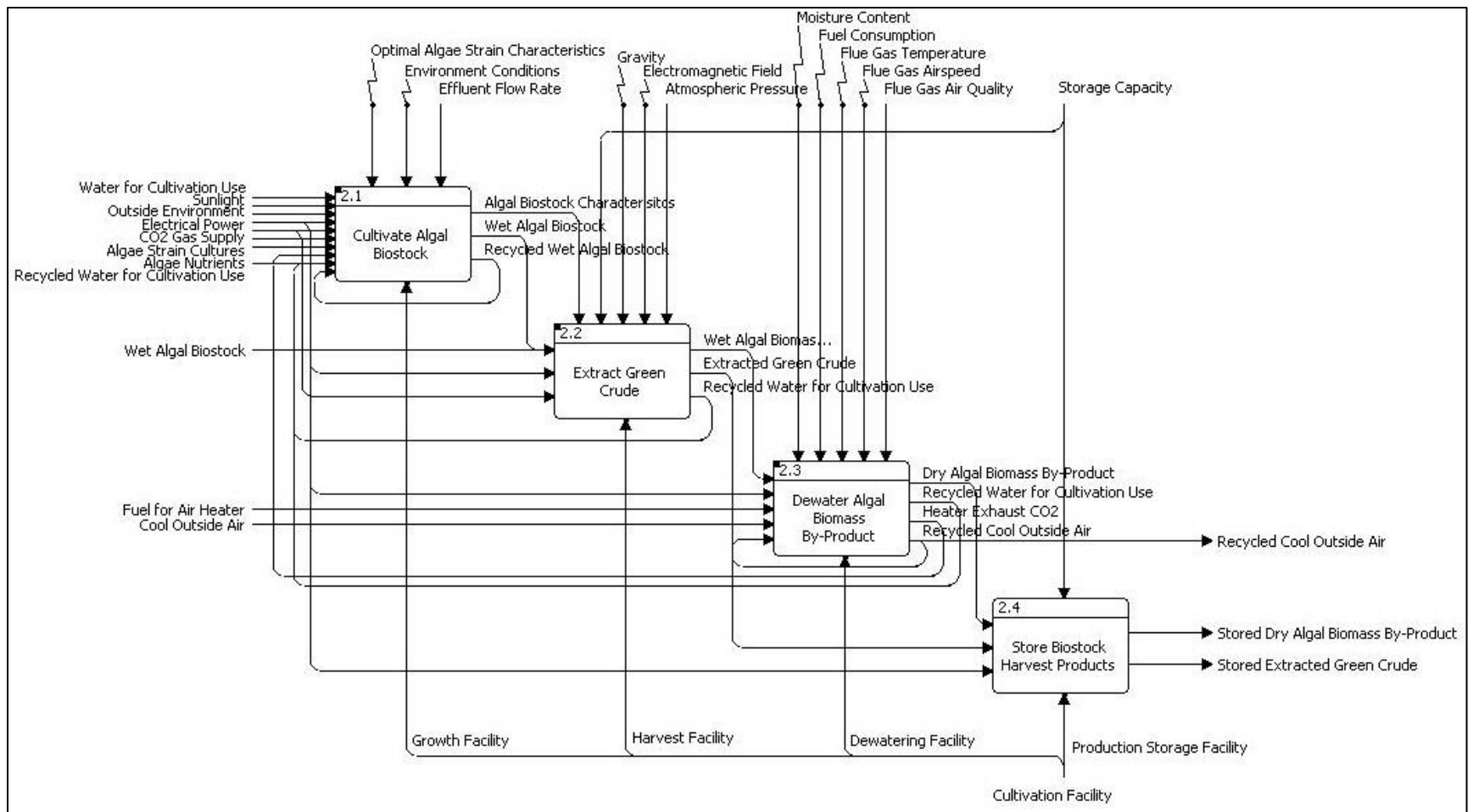

Figure 12. Produce Algal Oil (2.0) functional decomposition (IDEF0).

In the sections that follow, each of the five Tier 3 functions will be broken down, discussed in detail, and visualized using an IDEF0 diagram in order to better illustrate the flow of items within and between refinement system functions.

*a. Cultivate Algal Biostock (2.1) Functions*

The Cultivate Algal Biostock (2.1) function is the first and foremost functional node to begin the cultivation process. The IDEF0 flow diagram is refined into six functional capabilities: Apply Algal Biostock (2.1.1), Regulate Algal Nutrients (2.1.2), Circulate Algal Biostock Medium (2.1.3), Maintain Algal Growth Environment (2.1.4), Monitor Algal Biostock Growth (2.1.5), and Harvest Algal Biostock (2.1.6). These six functions capture the lower level capabilities for the cultivation process to produce algal green crude. The IDEF0 chart produced by the CORE<sup>®</sup> analysis tool for this function is depicted in Figure 13.

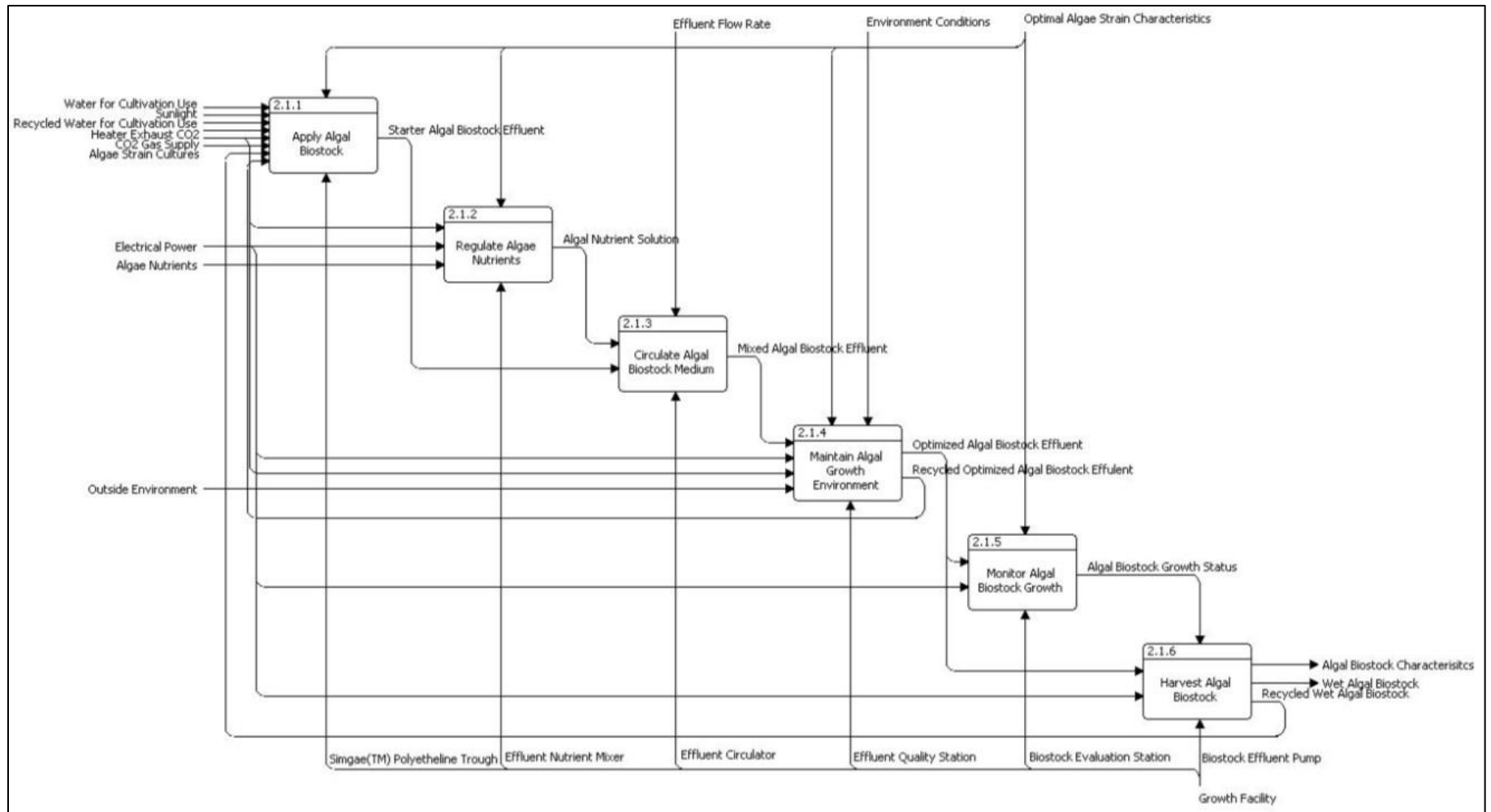

Figure 13. Cultivate Algal Biostock (2.1) functional decomposition (IDEF0).

Resources required for algal growth, including water, sunlight, CO<sub>2</sub> source, and the selected algae strain, are applied to the cultivation facility and later mixed downstream with regulated nutrients as required by the algae strain for efficient growth. Physical mixing of the algae biostock is required to ensure system equilibrium with exposure to sunlight and nutrient levels. Additionally, the growth environment is maintained and monitored for acidity levels, nutrient concentration, biostock temperature, and algal concentration/maturity. When appropriate, the biostock is harvested out of the system and transported to the next phase of the system. Water and other resources are recycled within the system to maximize efficiency and minimize waste between stages. Algal biostock is also recycled to seed the next growth phase and build up towards harvesting to induce a continuous growth process.

***b. Extract Green Crude (2.2) Functions***

Once harvesting is complete, the next phase of the cultivation process is captured in the Extract Green Crude (2.2) functional node and consists of the following sub-tier nodes: Store Cultivated Algal Biostock (2.2.1), Preprocess Algal Biostock (2.2.2), Process Algal Biostock (2.3.3), and Separate Process Biostock Products (2.2.4). These four functions represent the activities associated with extracting the green crude oil from the cultivated algal biostock through a series of steps that will be described in sufficient detail in the sections later to come. The IDEF0 chart produced by the CORE<sup>®</sup> analysis tool for this function is depicted in Figure 14.

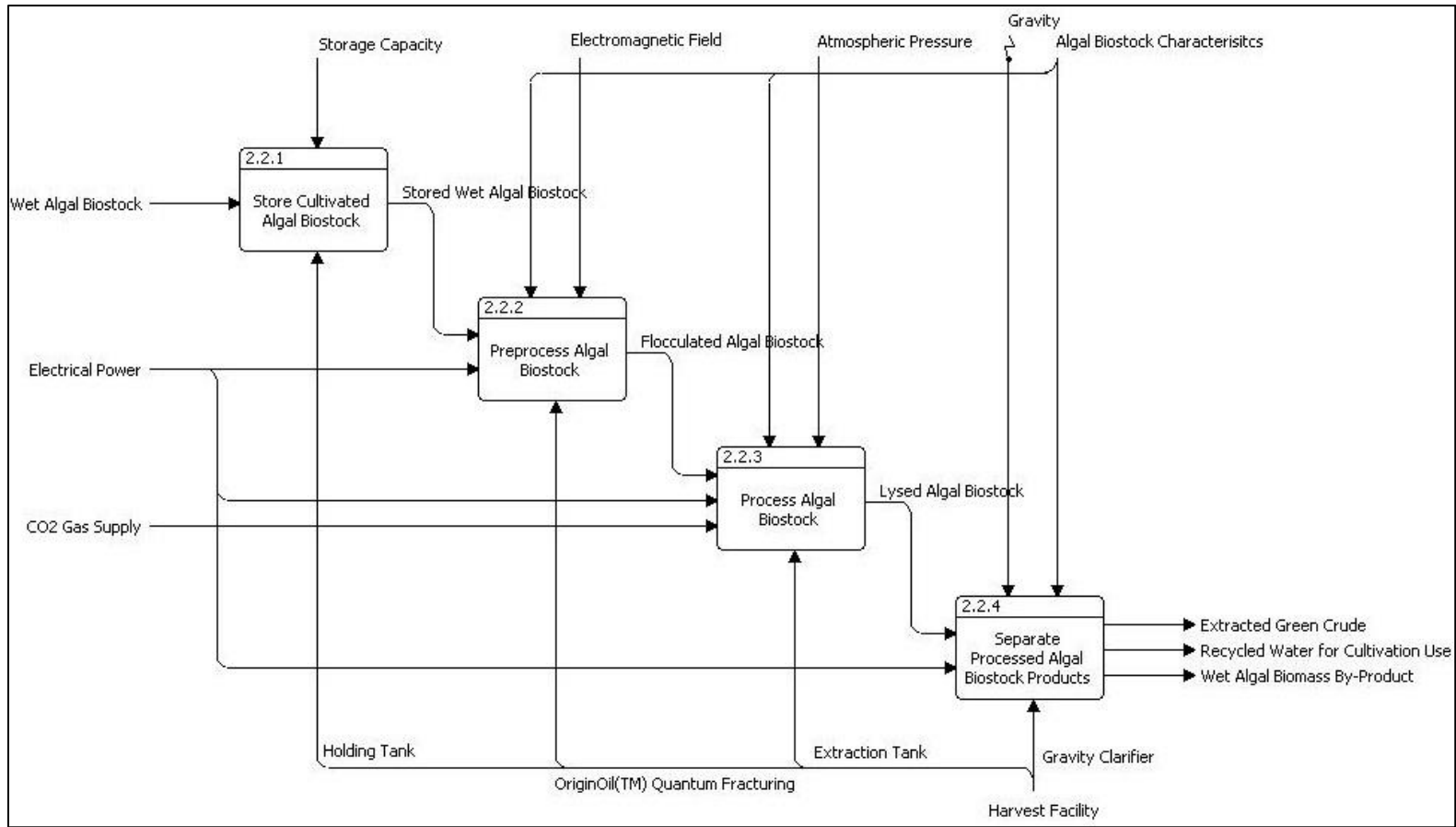

Figure 14. Extract Green Crude (2.2) functional decomposition (IDEF0)

The harvested algal biostock is introduced to this sub-tier system and stored until ready for processing. The system will enter into a series of steps to process the Algal Biostock in a process known as electroporation and is described in the sections to come. Once the process completes, the composition of the biostock is in state that is ready for component separation. Separation of the various components occurs within another node and the output products are passed onto the next appropriate phase within the cultivation process. These output products include extracted green crude, wet algal biomass by-product, and recyclable water.

*c. Dewater Algal Biostock By-Product (2.3) Functions*

After the algal biostock products are physically separated, the wet algal biomass by-product follows a product unique processing path. The Dewater Algal Biostock By-Product (2.3) function processes the wet algal biomass and is decomposed into the following seven functional nodes: Accelerate Flue Gases (2.3.1), Heat Flue Gases (2.3.2), Apply Algal Biomass By-product (2.3.3), Remove Algal Biomass By-product Moisture (2.3.4), Collect Airborne Dry Algal Biomass By-product (2.3.5), Scrub Exhausted Outside Air (2.3.6), and Exhaust Cool Outside Air (2.3.7). The IDEF0 chart produced by the CORE<sup>®</sup> analysis tool for this function is depicted in Figure 15.

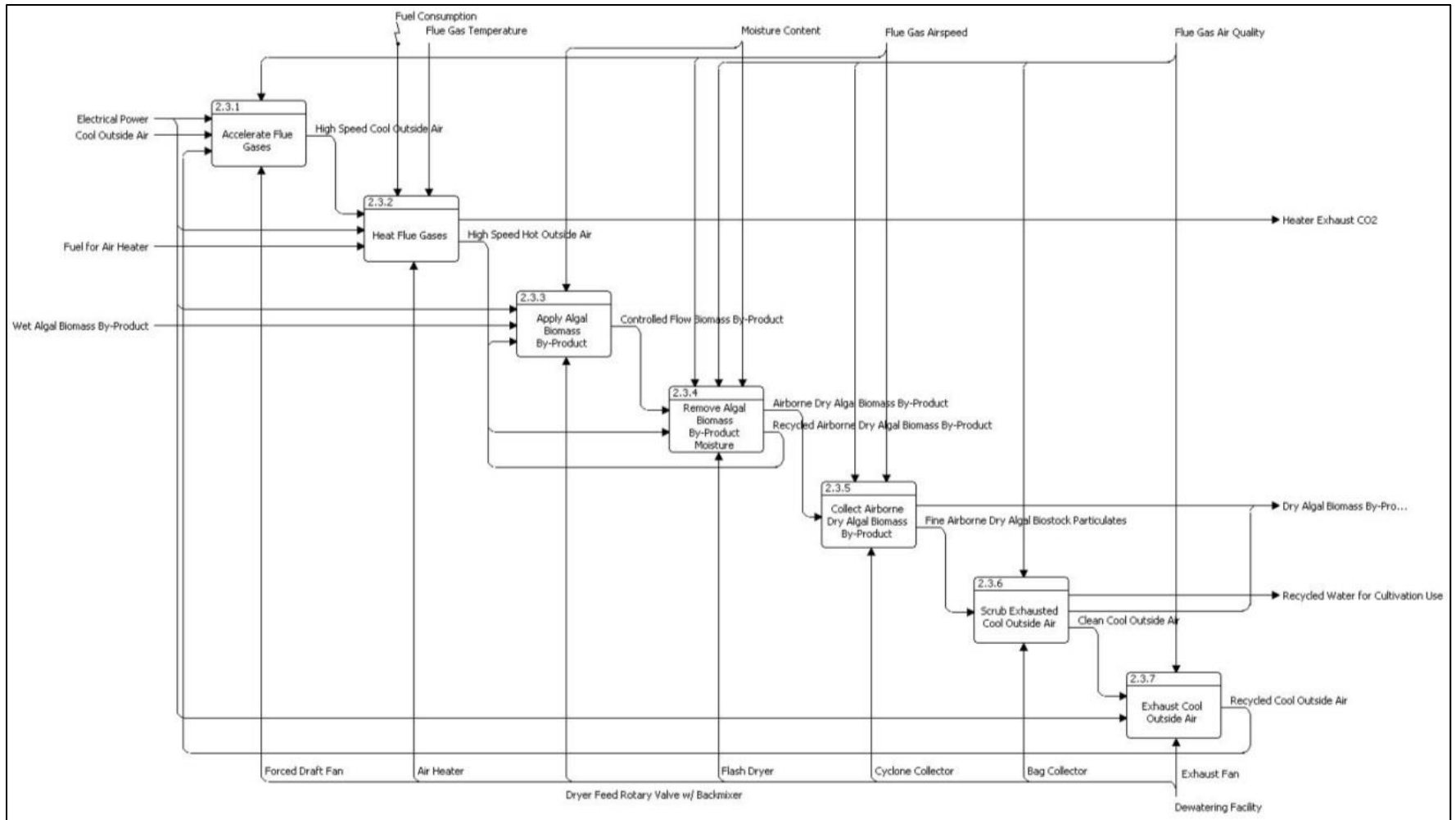

Figure 15. Dewater Algal Biostock By-Product (2.3) functional decomposition (IDEF0).

The functions depicted in this section are representative of the concluded design selection and represent a pneumatic dryer configuration from the Dewatering Analysis of Alternatives that will be discussed in-depth later. Prior to the introduction of the wet algal biostock, the dewatering system must accelerate and heat the air to desired speed/pressure and temperature. The wet algal biostock by-product is fed into the system and introduced into the hot airstream where the product is dispersed and moisture is removed. The dried algal biostock by-product then leaves the system and is filtered out of the air for collection and storage for future use as discussed in later sections. The exhausted air is recycled in the system to capitalize on heat recovery efficiencies as the cycle is repeated in a continuous process and represented by the feedback arrows looping to the previous sub-functions.

**d. Store Biostock Harvest Products (2.4) Functions**

After Biostock Harvest Product separation of the Extracted Green Crude and collection of the Dry Algal Biomass By-Product, storage may be required pending transport method from the Produce Algal Oil (2.0) to the Refine Algal Crude (4.0) via the Transport Green Crude Oil (3.0) function in the case of the Extracted Green Crude. For the Dry Algal Biomass By-Product material, storage may be necessary until some external agent purchases the product. The IDEF0 chart produced by the CORE<sup>®</sup> analysis tool for this function is depicted in Figure 16.

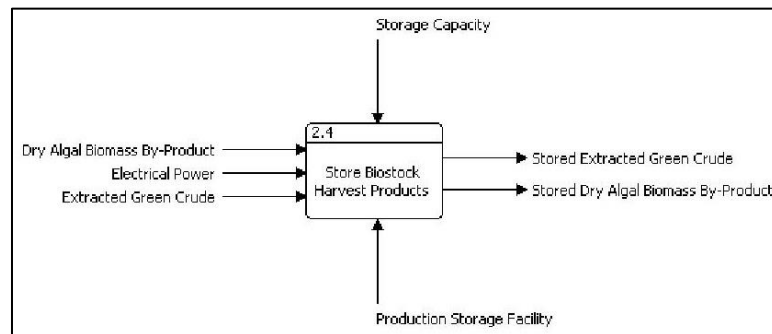

Figure 16. Store Biostock Harvest Products (2.4) functional decomposition (IDEF0).

#### **4. Refinement Functions**

Upon decomposition of the Refine Algal Crude (4.0) Tier 2 function, the flow diagram is refined into five Tier 3 functional capabilities, which are: Receive Green Crude (4.1), Refine Green Crude (4.2), Manage By-products (4.3), Post-Process Refined Product (4.4), and Manage Refining Resources (4.5) functions. These five functional nodes capture the main refinement functions required to perform the overall capability of growing algal biostock and harvesting the algal green crude, and will be discussed in the sections to come. The IDEF0 chart produced by the CORE<sup>®</sup> analysis tool for this function is depicted in Figure 17.

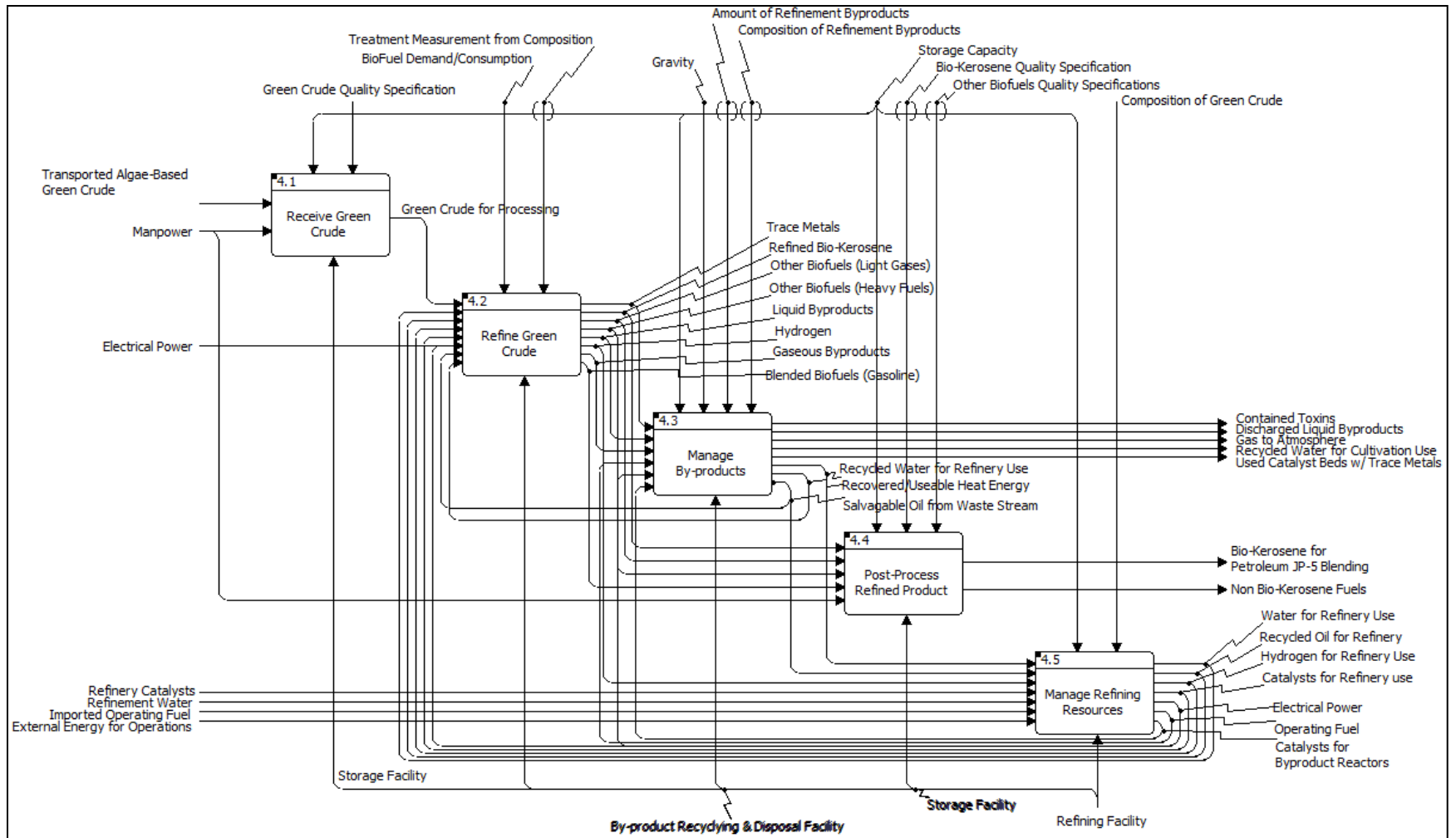

Figure 17. Refine Algal Crude (4.0) functional decomposition (IDEF0).

In the sections that follow, each of the five Tier 3 functions will be broken down, discussed in detail, and visualized using an IDEF0 diagram in order to better illustrate the flow of items within and between refinement system functions.

*a. Receive Green Crude (4.1) Functions*

The Receive Green Crude (4.1) Tier 3 function comprises of three Tier 4 sub-functions: Perform Composition/Quality Check of Green Crude Oil (4.1.1), Store Green Crude Oil (4.1.2), and Route Green Crude Oil for Processing (4.1.3) functions. A sample of all green crude shipments from the Cultivation System will be tested and analyzed in order to determine the chemical composition of the green crude. This is a necessary function, because not all green crude produced by the Cultivation System will have the same chemical composition. The chemical composition will determine how the crude is refined and the catalysts that are required.

Store Green Crude (4.1.2) function is a simple storage function that allows green crude to be stored prior to any refinement and from here it will be routed for refinement processing via Route Green Crude Oil for Processing (4.1.3) function. The Store Green Crude (4.1.2) function allows for the throughput of the HNAABS Refinement System to be regulated pending the current demand and status. An IDEF0 diagram of the Receive Green Crude (4.1) function can be viewed in Figure 18.

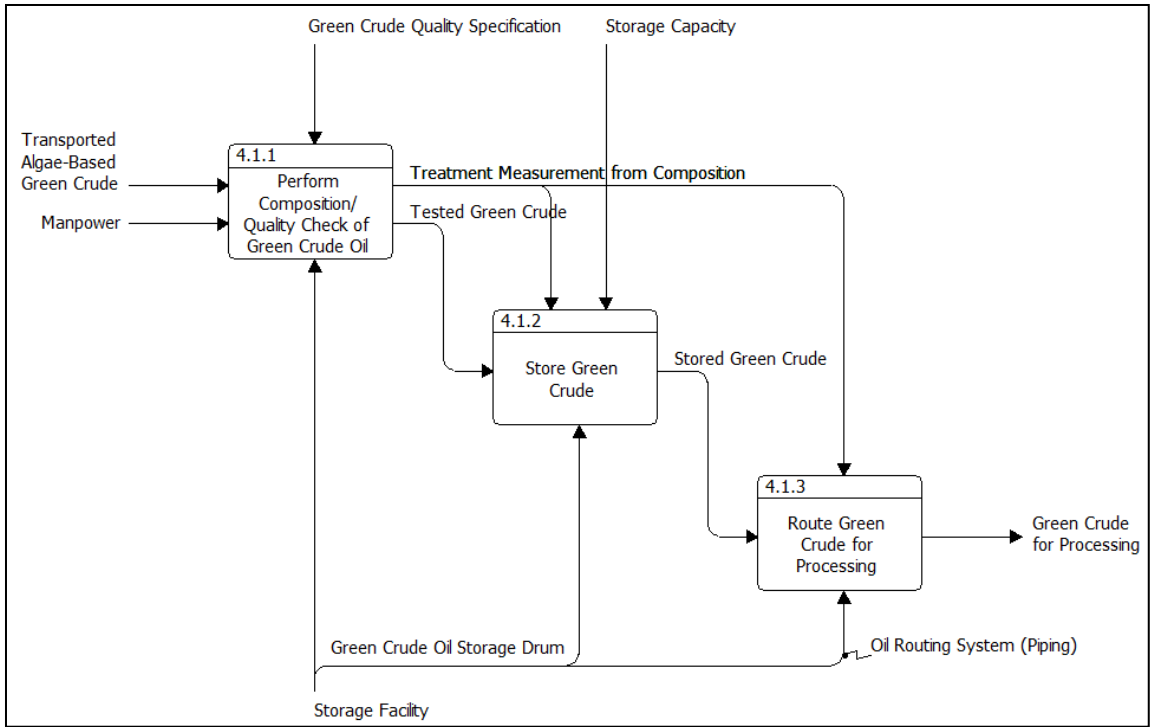

Figure 18. Receive Green Crude (4.1) functional decomposition (IDEF0).

The inputs and outputs of each Tier 4 function in Figure 18 show how the oil and other items are passed between functions. Figure 18 also shows the system components that are responsible for each sub-function, as well as the controls that enable and impact the sub-function. The depiction of the inputs, outputs, controls, and components (i.e., mechanisms) is true for all of the IDEF0 figures in this section as well.

**b. Refine Green Crude (4.2) Functions**

The refinement of the green crude will be subject to three primary processing steps. A high level view of the HNAABS refinement process can be viewed in Figure 19.

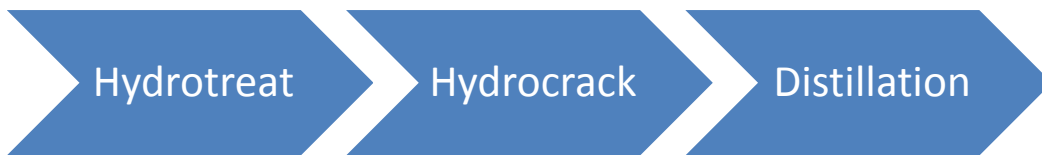

Figure 19. High-level architecture of the HNAABS refinement process.

The three steps (Hydrotreat, Hydrocrack, and Distillation) listed in Figure 19 are essential steps to create bio-kerosene of high enough quality to be used in DoD aircraft jet engines.

The initial step, known as hydrotreating, is essentially for the ‘cleaning and decontamination’ of the green crude that is produced by the HNAABS Cultivation System. During this step, multiple reactions are forced upon the crude, which in turn, relieve it of its undesirable contents. Contrary to petroleum crude, which has high concentrations of sulfur, green crude from algae has high concentrations of nitrogen and oxygen (Phukan, et al. 2011). The nitrogen is removed from the green crude by a reaction process known as hydrodenitrogenation. Hydrodenitrogenation utilizes a catalyst in the presence of hydrogen to break the carbon-nitrogen bond in the oil molecule and replace it with hydrocarbon bond. The byproduct of the reaction is ammonia gas ( $\text{NH}_3$ ) (Schwartz 2000). The by-product ammonia gas can be broken down into its separate elements (Nitrogen and Hydrogen) and reused, or it can be sold. The oxygen is removed from the green crude through a reaction process known as hydrodeoxygenation. Hydrodeoxygenation removes the oxygen from the crude oil in the form of  $\text{CO}$ ,  $\text{CO}_2$ , and  $\text{H}_2\text{O}$  (Solomons 2002). The hydrodeoxygenation reaction process is discussed in detail in Section III.C. Finally, during the Hydrotreatment process, trace metals, such as sodium, potassium, phosphorus, calcium, and magnesium, will be removed from the oil. During the process, the trace metals adhere to, and form deposits on, the reaction catalysts. The end result of the Hydrotreatment process is straight chain hydrocarbon paraffins that range in length from approximately 15 to 18 carbon atoms (Carlson, et al. 2010).

The next step in the refinement process is known as Hydrocracking. During the Hydrocracking process, the straight chain hydrocarbon paraffins, which are a composition similar to that of diesel fuel, will be converted into highly branched hydrocarbons, which is the molecular structure for bio-kerosene (Scherzer and Gruia 1996).

Figure 20 is a visual depiction of the hydrocracking process and shows how the molecular structure of the oil changes from a straight chain structure (i.e., diesel) at the beginning to a highly branched structure (i.e., bio-kerosene) at the end.



Figure 20. Molecular structure change during hydrocracking process.

In order to achieve the branched and desired molecular structure, the straight chain paraffins are first combined with high pressure hydrogen. The reaction converts them into a hydrogenated ring-like molecular structure. Next, a crystalline aluminosilicate catalyst (more commonly referred to as a zeolite) is introduced (Speight 2007), which breaks the bonds in the hydrogenated ring-like molecular structure to form many small olefinic double bonds of unsaturated hydrocarbons. The unsaturated hydrocarbons then react with hydrogen gas to form isoparaffins. These isoparaffins have a lower molecular weight than the original straight chain paraffins, and are the highly branched and desired molecules that make up bio-kerosene (Scherzer and Gruia 1996).

The final step in the HNAABS refinement process is Distillation, more specifically Fractional Distillation. During the first two steps, not every bit of oil will be converted into the desired bio-kerosene. It is estimated that algae derived green crude can yield up to 70% bio-kerosene, which can be used to produce green jet fuel (Sapphire Energy 2009). However, there are some other byproducts that include, but are not limited to diesel and naphtha. In order to separate the different products, the oil is heated in a fractional distillation tower and separated based on boiling point. The lighter oils with lower boiling points will rise to the top of the distillation tower, while the heavier oils with higher boiling points will remain at the bottom.

After being separated, the bio-kerosene is moved to post processing (Function 4.4), while some of the by-products are further refined via Function 4.2.4. The

Reform Other Biofuels (4.2.4) function contains the processes for refining biofuels other than bio-kerosene, such as gasoline and diesel. It should be noted that although they are not included in the cost estimate, the other biofuels will be sold to offset refinement costs. This function and its associated sub-functions will allow the HNAABS to take advantage of the other oil byproducts and produce usable transportation and energy fuels for the state of Hawaii. An IDEF0 diagram for the Refine Green Crude (4.2) function can be viewed in Figure 21. The diagram shows the flow of items between each of the sub-functions previously described.

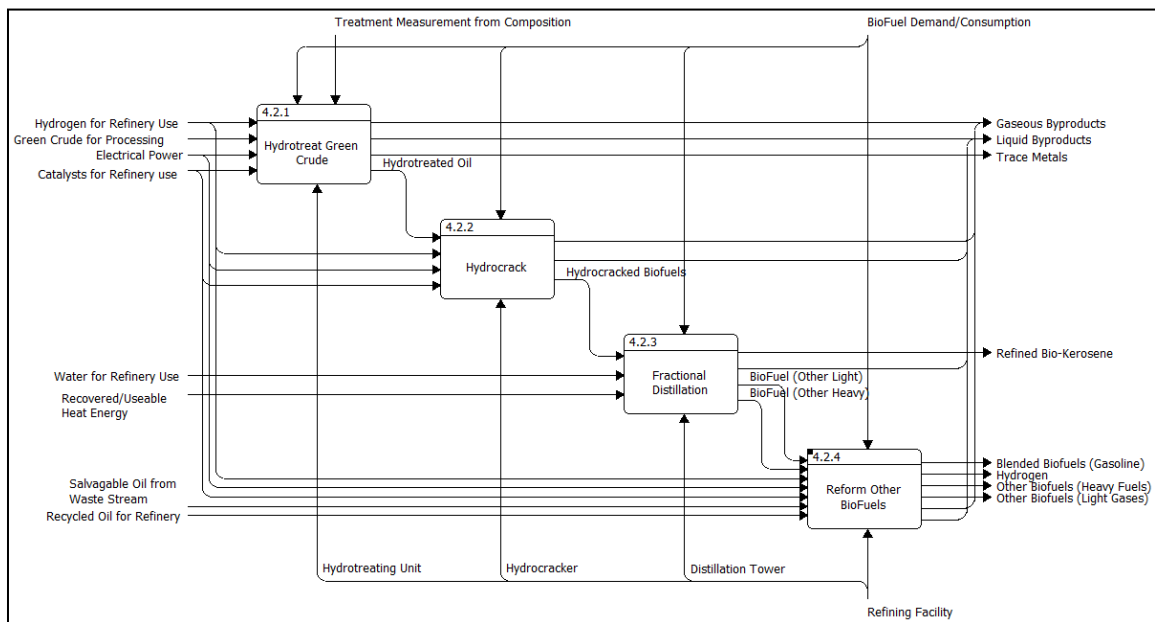

Figure 21. Refine Green Crude (4.2) functional decomposition (IDEF0).

**c. Manage By-products (4.3) Functions.**

The By-product Recycling and Disposal Facility is a key aspect to the HNAABS Refinement System. All by-products exiting the HNAABS Refinement System will be sent to the By-product Recycling & Disposal Facility and be subject to Manage By-products (4.3) function. There are three primary sub-functions associated with the Manage By-products (4.3) function. These sub-functions are Manage Liquid & Solid By-products (4.3.1), Manage Gaseous By-products (4.3.2), and Discharge Non-Recycle By-

products from Facility (4.3.3). An IDEF0 diagram of the Manage By-products (4.3) function can be viewed in Figure 22.

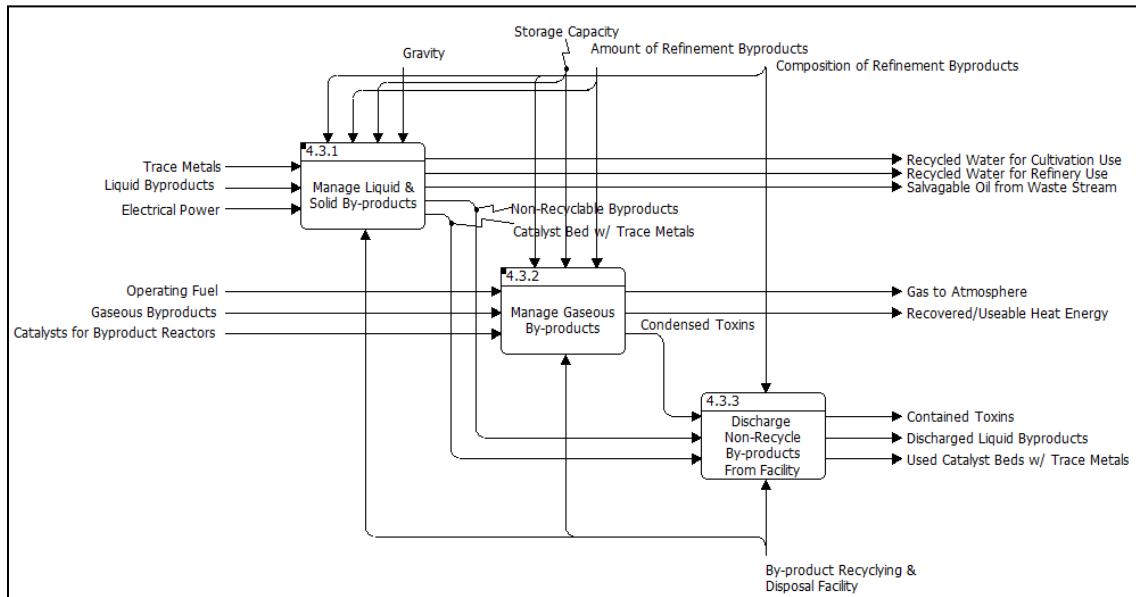

Figure 22. Manage By-products (4.3) functional decomposition (IDEF0).

Dependent on the state (solid, liquid, or gas) of the by-product, the by-product will be subject to one of two recycling and disposal paths. Both solid and liquid by-products will be managed according the process described in Figure 23, which is an IDEF0 Diagram for the Manage Liquid & Solid By-products (4.3.1) function.

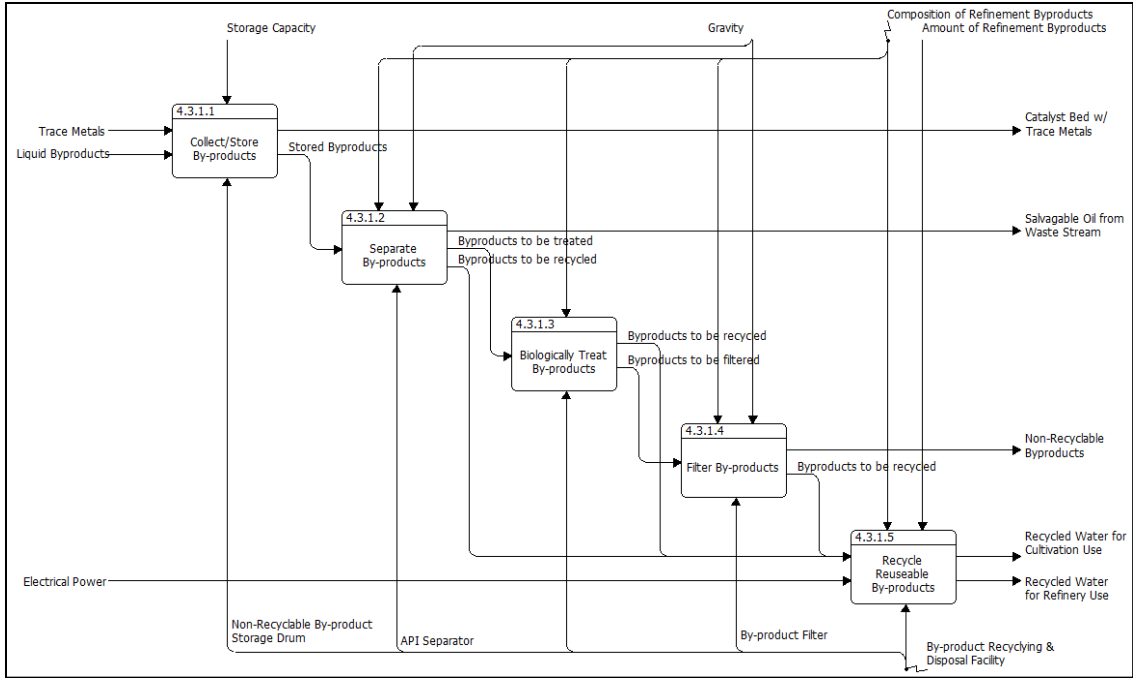

Figure 23. Manage Liquid & Solid By-products (4.3.1) functional decomposition.

All liquid and solid by-products will be collected and/or stored and then separated by an American Petroleum Institute (API) Separator upon entering the By-product Recycling & Disposal Facility. After being separated, and dependent upon the composition, the by-products will be biologically treated and filtered, recycled, or sold to offset refinement costs. The biological treatment of a by-product is an effort to make the material less harmful to the environment thus allowing for more disposal or recycling options. It should be noted that ‘solid’ by-product refer to any contaminants or ‘sludge’ that may be in the typically liquid based by-product stream.

The management path for gaseous by-product is significantly different than that of liquid and solid by-products. Gaseous by-product management requires different functions and its own separate infrastructure and components. An IDEF0 diagram for the Manage Gaseous By-product (4.3.2) function can be viewed in Figure 24.

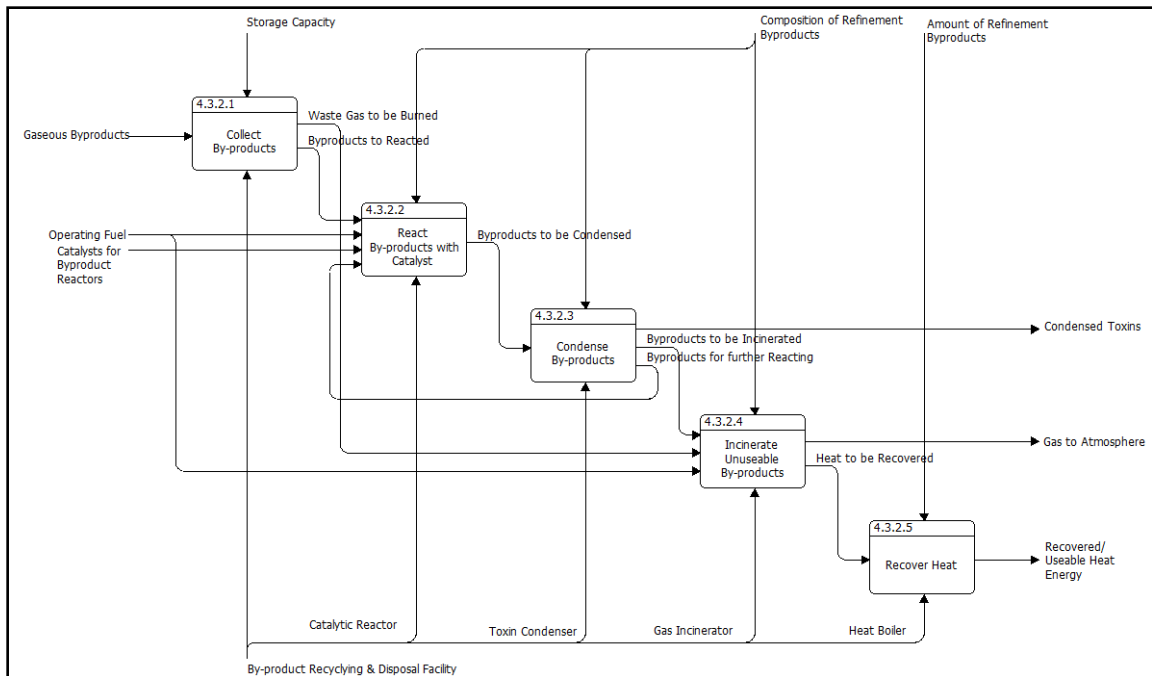

Figure 24. Manage Gaseous By-product (4.3.2) functional decomposition (IDEF0).

Upon being collected from the oil refinement process, the gaseous by-product is burned and then combined with various catalysts in a catalytic reactor. The by-product from the chemical reaction will then be condensed in order to remove all of the toxins, and then either incinerated or re-combined with more catalysts (Zeeco 2011). The condensed chemicals and toxins are properly sealed, stored and removed from the facility. The by-product that is incinerated is released to the atmosphere while the heat from the incinerator is recovered and used as a source of energy for the refinery. Recovering the heat from the incinerator, along with recycling water, will allow the HNAABS refinery to maintain high efficiency, consume fewer resources and decrease utility costs.

The third high level function of the By-product Recycling & Disposal Facility, Discharge Non-recyclable By-products From Facility (4.3.3), is responsible for removing the condensed toxins and unusable water from the facility. The water will likely be transported via pipelines and the condensed toxins will likely be transported via truck for disposal in accordance with local regulations. Local environmental and legal

regulations are discussed in detail in Section IV. The treatment and analysis of this water stream will be discussed in further detail in Section III.C.

Examples of by-products that can be recycled and reused by the refinement system are hydrogen, which is used to hydrocrack the crude oil, and water, which can be used by a fractional distillation unit for cooling or even by the HNAABS Cultivation system to grow the algae that produces the oil. The By-product Recycling & Disposal Facility is based on a petroleum crude waste management system. All the By-product Recycling & Disposal Facility functions and components are aimed at meeting or exceeding all environmental laws and regulations, as well as maximizing efficiency through recycling.

**d. Post-Process Refined Product (4.4) Functions**

The Post-Process Refined Product (4.4) function is responsible for handling the refined bio-fuels (bio-kerosene and other bio-fuel products) after it has completed the refinement process. An IDEF0 diagram of the function and its corresponding sub-functions can be viewed in Figure 25.

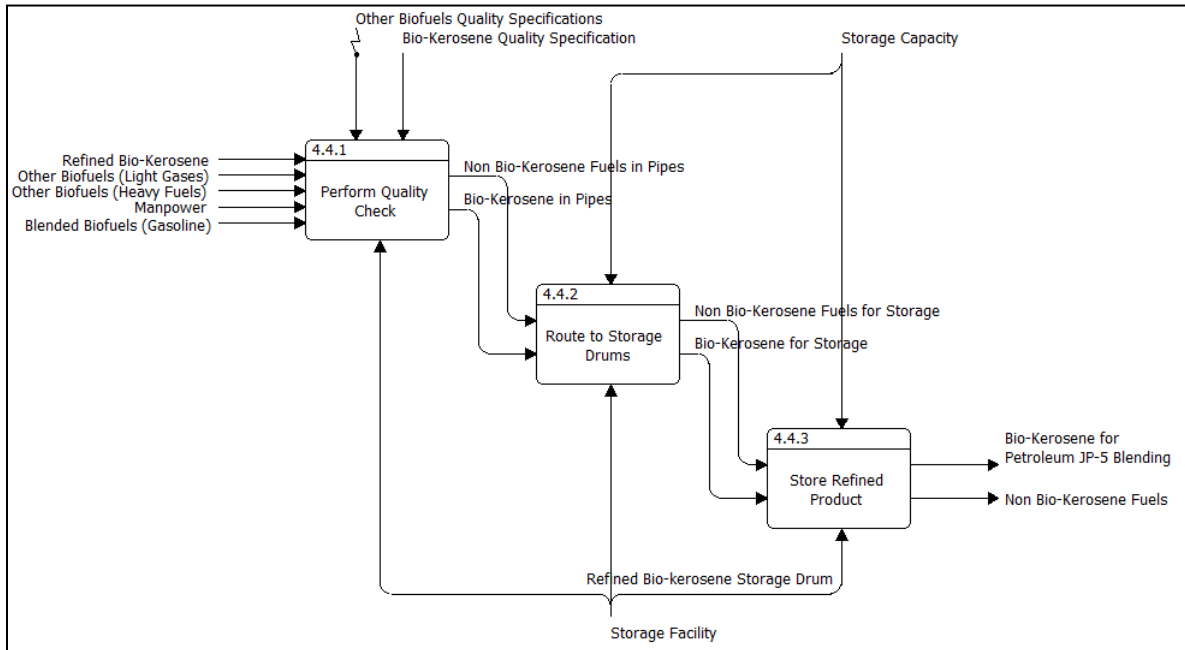

Figure 25. Post-Process Refined Product (4.4) functional decomposition (IDEF0).

All biofuels exiting the Refine Green Crude (4.2) function are inputs to the Post-Process Refined Product (4.4) function. A sample of each biofuel will be tested via Perform Quality Check (4.5.1) function, to ensure it is of the proper composition and meets specifications for the given fuel type. All biofuels will be stored in certified biofuel storage containers within the Store Facility located on-site to the HNAABS Refinement System. The biofuel is then available to be transported to the customer for use or blending with petroleum based fuels.

*e. Manage Refining Resources (4.5) Functions*

The Manage Refining Resources (4.5) function is responsible for management of all non-oil resources. Non-oil resources consist of hydrogen, water, energy, and catalysts that are utilized by Function 4.2 and are necessary for the refinement of the green crude. An IDEF0 diagram of the Manage Refining Resources function can be viewed in Figure 26.

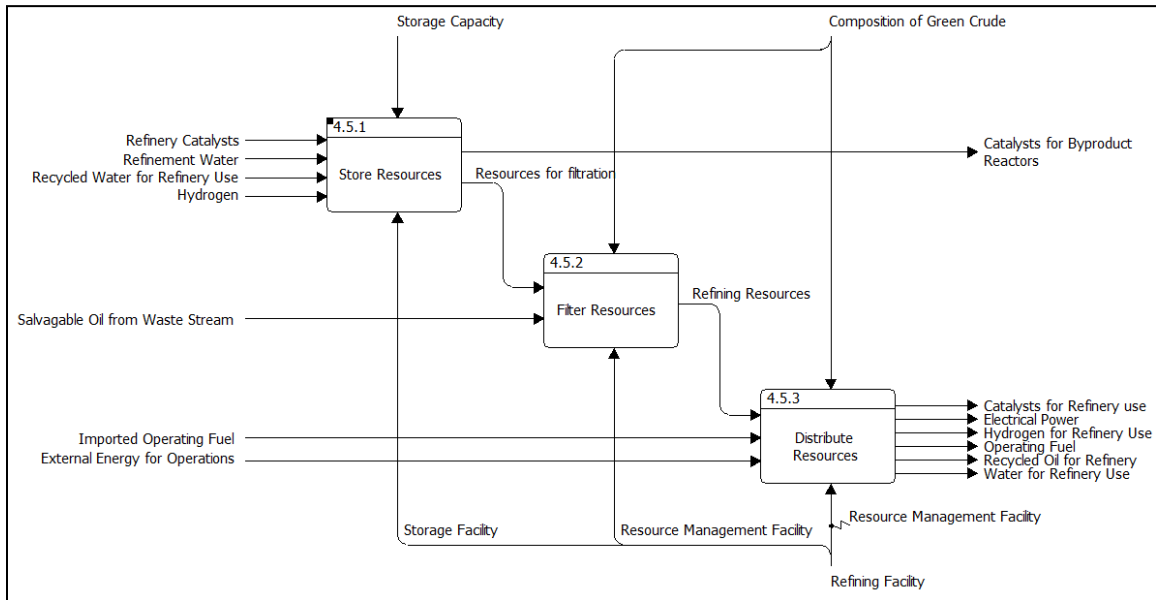

Figure 26. Manage Refining Resources (4.5) functional decomposition (IDEF0).

There are three sub-functions that make up the Manage Refining Resources function: Store Resources (4.5.1), Filter Resources (4.5.2), and Distribute Resources (4.5.3) functions. The Store Resources (4.5.1) sub-function will store both recycled resources supplied by the Manage Waste (4.3) function, and resources imported

or delivered from outside sources to the HNAABS Refinement System. The HNAABS Refinement System will also have the capability to filter the resources as necessary through the Filter Resources (4.5.2) function. Filtering the resources will ensure that high quality and the proper resources are supplied to the Refine Green Crude (4.2) function. The distribution of resources to the actual refining portion of the facility will be handled in Function 4.5.3. Distribution of resources will be dependent on the current throughput of the refinement facility as well as the composition of the green crude being refined.

All figures in this section of the report were taken directly from the CORE<sup>®</sup> file. A complete and detailed functional decomposition and analysis is contained in the HNAABS CORE<sup>®</sup> file that can be made available upon request. Please submit requests through the Naval Postgraduate School Thesis Processing Department. This file is also available for download at <http://diana.nps.edu/~dholwell/HNAABS/index.htm>.

## **C. FEASIBILITY OBJECTIVES**

The HNAABS feasibility objectives are linked to the HNAABS Requirements listed in Appendix A. The HNAABS Team divided these feasibility objectives into three categories, which are: Performance, Environmental, and Cost objectives. The following sections detail these three feasibility objectives.

### **1. Performance Objectives**

The HNAABS Team focused the performance objectives of HNAABS to answer the question: “Can a HNAABS-like system be developed and built?” Therefore, the performance objectives of HNAABS are:

- Achieve a final product quality that meets or exceeds bio-kerosene type aviation grade turbine fuel
- Achieve a total HNAABS throughput of 32 million gallons of the aforementioned product quality
- Achieve and maintain an Operational Availability (Ao) of 90% or greater

These performance objectives were conveyed in more detail in the HNAABS requirements located in Appendix A.

## **2. Environmental Objectives**

The HNAABS Team focused the environmental objectives of HNAABS to answer the question: “Can a HNAABS-like system be developed and built *in Hawaii?*” The HNAABS Team divided this objective into three parts, which were: Energy, Water, and Land. The environmental objectives of HNAABS are:

- Design and build an HNAABS-like system within the constraints of the existing energy grid and infrastructure in Hawaii
- Design and build an HNAABS-like within the constraints of the existing water resources and infrastructure in Hawaii
- Design and build an HNAABS-like system without re-zoning current lands

These environmental objectives were formalized in more details into the HNAABS requirements, which are located in Appendix A.

## **3. Cost Objectives**

The HNAABS Team focused cost objectives to answer the question: “Can a HNAABS-like system be developed and built in Hawaii *at final product cost of \$3 per gallon or better?*” Therefore, given the performance and environmental objectives listed above, the cost objectives of HNAABS are:

- Design and build a HNAABS-like system that meets the performance and environmental objectives of HNAABS with a Free On-Board cost of \$3 per gallon.

THIS PAGE INTENTIONALLY LEFT BLANK

### **III. SYSTEM DESIGN**

The system design process describes the approach and methods that were utilized to objectively determine the best configuration for a biofuel production system by looking at a set of system alternatives to choose from. The process is bound by the specification requirements and problem definition. This section describes the methods and reasoning for the final recommended system configuration.

#### **A. SYSTEM DESIGN PROCESS**

The system design process is broken up into the two discrete portions of the processes of cultivation (growing and harvesting the algae culture) and refinement (processing the algae oil into usable fuels per the system specification requirements).

Due to the large number of possible system alternatives for the cultivation system (5 Growth, 5 Harvest, 5 Dewater, and 4 Extraction or  $5 \times 5 \times 5 \times 4 = 500$  combinations), a comparative analysis of alternatives (AoA) for the sub-functions within the cultivation process was conducted. An analysis of alternatives was performed for each of the following cultivation functions:

- Growing. Grows the algae culture to a mature enough level to maximize oil content within the algae culture
- Harvest. Separates the algae culture from the growth medium
- Dewatering/Drying. Minimizes water content within the harvest algae culture
- Extraction. Separates the algal oils from the dewatered/dried algae culture for processing to refinement

The refinement component looked at three different possible system configurations that could be possible for integration within the state of Hawaii. The system alternatives are as follows:

- Retrofitting an existing petroleum refinery into a solely bio-fuel facility
- Building a new bio-oil refinery
- Hybrid petroleum and bio-oil refinery

The analyses of alternatives are conducted so that there can be an objective comparison among the various system options, where all the major facets are considered.

## **1. Methodology and Approach**

### *a. Cultivation Analysis of Alternatives Method*

The Cultivation analysis of alternatives was specifically constructed to objectively compare many varying system configurations. A separate analysis of alternatives was performed for each major discrete subsystem of the cultivation system. These subsystems included growth, harvesting, dewatering, and extraction. In some scenarios, specific subsystems can perform more than one function, thus avoiding the need for all four subsystems. For example, a photobioreactor system with Quantum Fracturing™ oil extraction does not require any other systems as the harvesting, dewatering, and extraction is performed by the quantum fracturing subsystem.

The cultivation system was broken up into four components (growth, harvest, dewater, and extract) described in the previous section. To select the best alternative for each component, four analyses of alternatives were performed. Figure 27 describes how the four subsystem alternatives were selected for final configuration selection. For the final configuration selection, multiple cultivation systems were analyzed in more detail. A customized method of the analytic hierarchy process (AHP) was utilized to perform analyses of alternatives for each of the four cultivation stages. AHP is a general technique for breaking up complex decisions into an analytic hierarchy of smaller and less complex decisions (Saaty 2008) (Triantaphyllou and Mann 1995). This provided a framework to decide the top cultivation configurations that underwent detailed cost and performance analysis described in Section V.

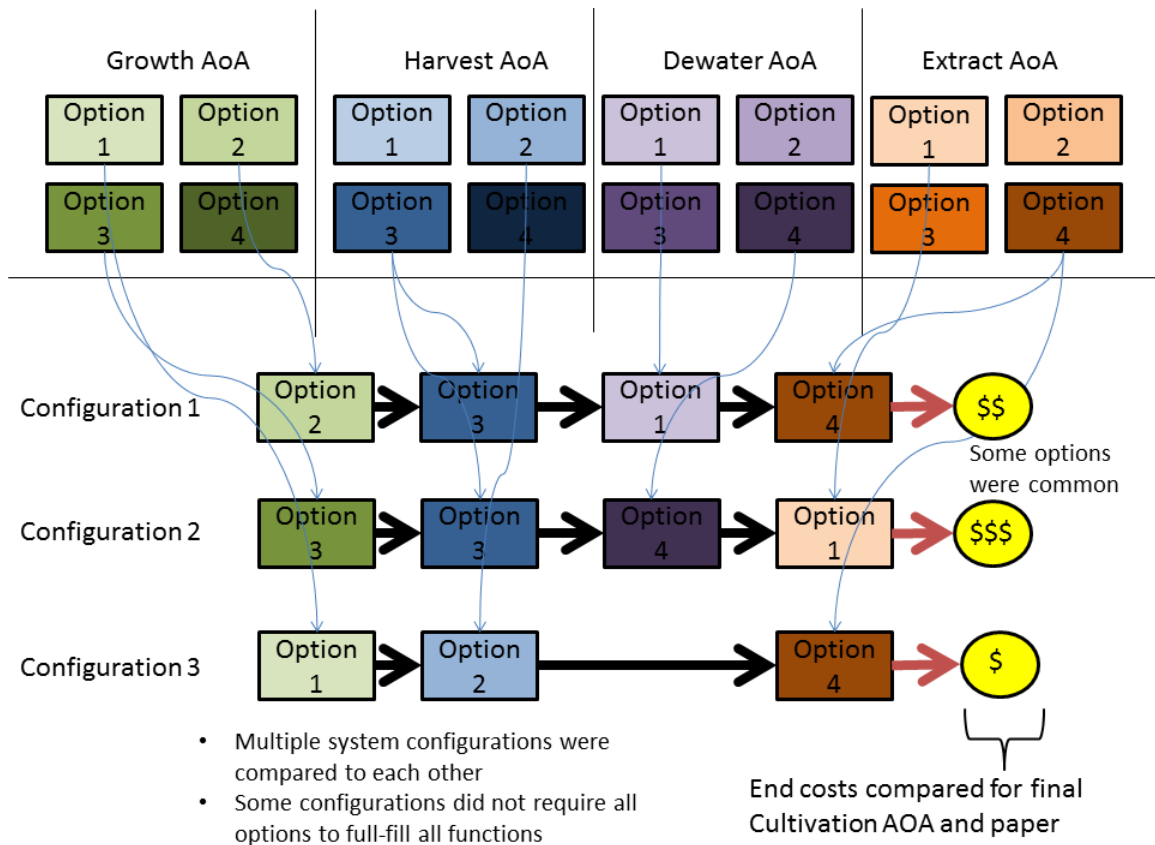

Figure 27. Graphical description of the cultivation system configuration selection. Based on the analysis alternatives results, various final configurations were chosen for final selection for the HNAABS cultivation system.

An analysis of alternatives was performed on each of the four stages of cultivation that the decision process was broken up into. The analysis of alternatives process utilizes a form of concurrent engineering called quality function deployment (QFD) to aid in determination of what subsystems options were selected. Quality function deployment is a tool that is able to aid the design of a system by working with user requirement priorities (Bahill and Chapman 1993). The tailored quality function deployment (QFD) process was utilized to take requirements priorities and map them to the performance of the major components of the cultivation system. Figure 28 shows the general process that was performed to determine what subsystems alternatives should be selected. To quantitatively weight each requirement priority to all the other key priorities, a pairwise comparison matrix was created. Through this, a determination of the relative

importance of one requirement over the other is made. With the priorities weightings, a series of House of Quality (HoQ) matrices were created to map the priorities through system design characteristics, system functions, and system components. The HoQ matrices are the tools by which the QFD process is performed (Hauser and Clausing 1988). The weighting results of the pairwise matrix determine another scoring of requirements versus each other and allow the metrics HoQ chart to be built. The weights that result from the interrelationship scoring show the interaction between a requirement priority and a design characteristic of the system.

In the next iteration, the previous weighting results from the requirements priorities and design characteristics interrelationship scoring are used to score the interrelationship of the design characteristics to the functions of the system. Finally, the last diagram will compare functions to the physically allocated components of the system. For each chart, the weighting from the previous chart will be incorporated to determine a final performance weighting.

Once weightings are available, the team identified all available system alternatives available for selection. The team rejected any obvious outliers and selected the top candidates for weighting analysis. The alternatives investigated are described at the beginning of each analysis of alternatives discussion in the next sections. The team performed Pareto optimization to determine the best alternative selection based on performance.

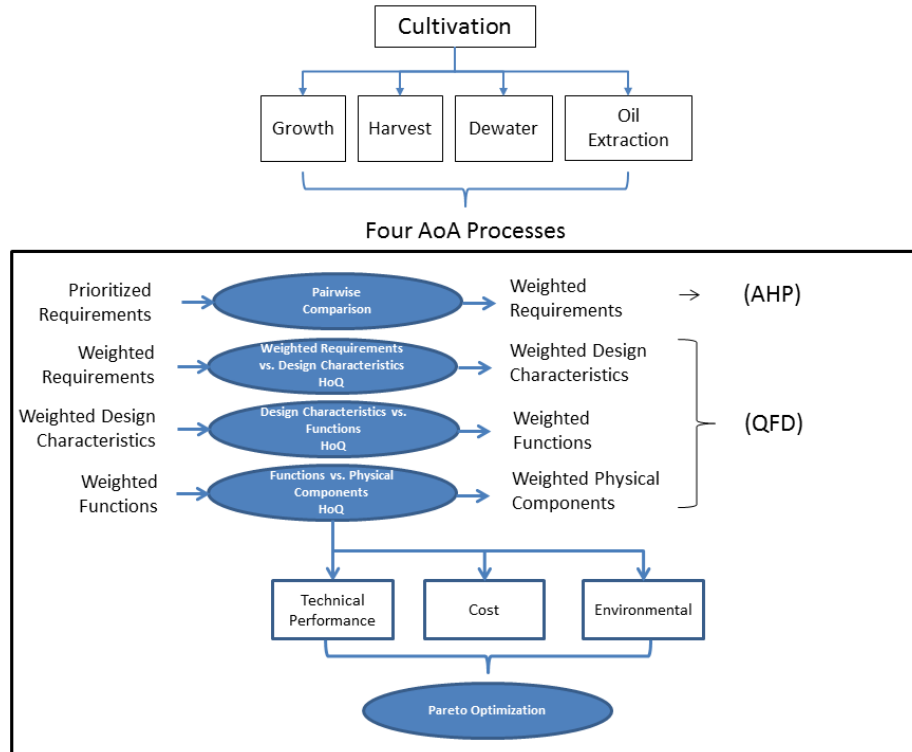

Figure 28. Diagram of the general decision analysis performed to determine the final configuration of the cultivation system. The process is derived from AHP, QFD, and Pareto optimization processes.

The analysis of alternatives process for each cultivation subsystem followed a step-by-step method described in Figure 29. The analysis of alternatives process must identify the top level value system structure that results in a pairwise comparison. The needs analysis and functional allocation define the external systems input/output model for mapping the functions the cultivation system performs. The functional analysis identified the top level functions that the cultivation aspect of the system will have to perform, along with the system specification requirements that map to the functions that require a cultivation system. With the functional allocation definition, the process then identified the physical subsystems that map to the functions to assist in the quantitative trade-off analysis. The following process outlines the analysis of alternatives steps performed on the cultivation system to score the importance of various physical factors of the cultivation subsystem all the way back to the initial stakeholder requirements:

To perform the decision process described in Figure 27 and Figure 28, the matrices described in Figure 29 show the general set of steps performed to take requirements priority scores and use them to describe the performance weighting of the individual components within the subsystem. Section III. B. describes the process and results for each cultivation subsystem. From Figure 29, (1) the requirements are prioritized by order of importance when compared to an expected baseline priority distribution. In (2), the prioritized scores are compared to each other to develop a prioritization matrix. In (3), the requirements priorities are scored by their level of interrelationship with design characteristics and are weighted according to the importance of the requirements priorities. In (4), the design characteristics and system functions are scored according to their level of interrelationship. The scores are then prioritized according to the level of weight each design characteristic holds. In (5), the system functions are scored according to the level of interrelationship with the system functions. The component weights are based on their level of importance to the total system function. This process provides a final performance weighting on the important of each component within the system, based on the original requirement prioritization.

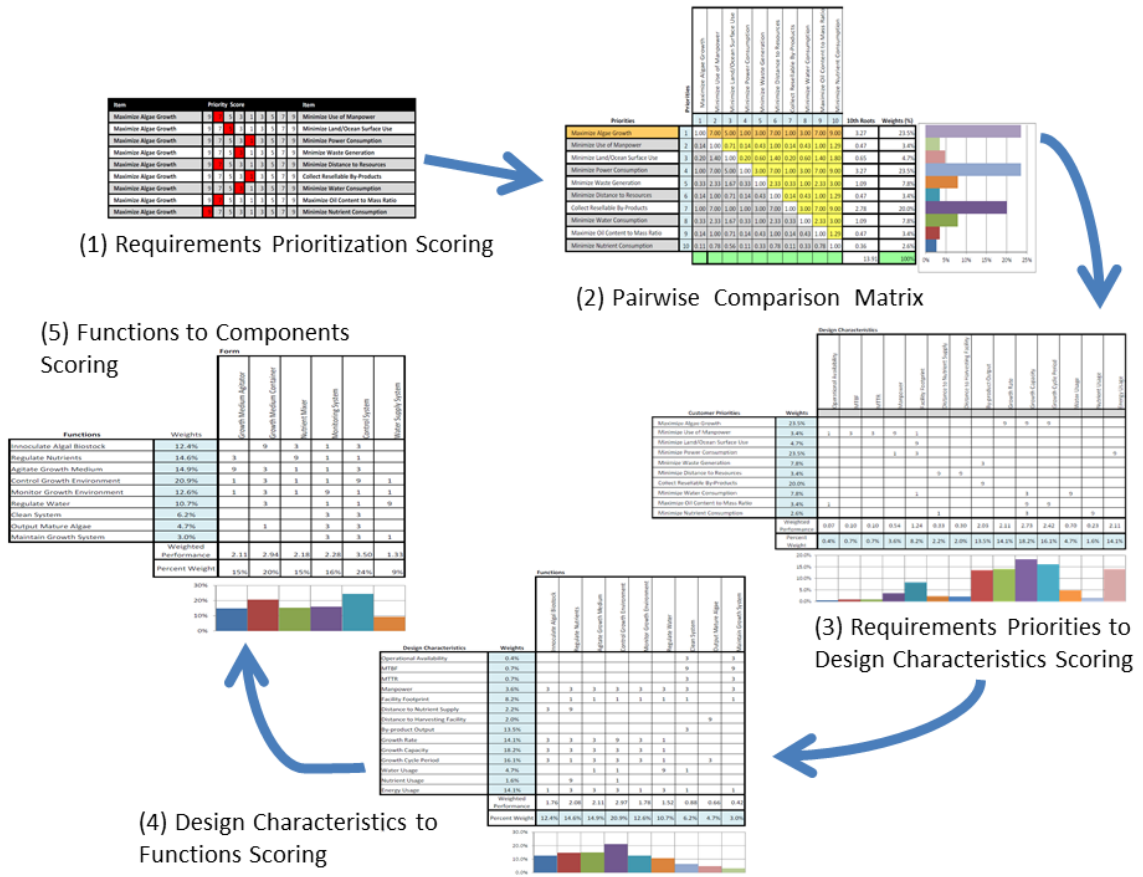

Figure 29. QFD process utilizing requirements priorities to determine the weighting each component has within a given subsystem. This process was performed for each of the four cultivation subsystem analyses of alternatives. This flow shows the actual matrices resulting from the growth analysis of alternatives.

The scores generated from the QFD process shown in Figure 29 are the performance weights used in the beginning of the alternative comparison process shown in Figure 30. In this phase, the performance weights, combined with the performance scoring for each system alternative, provide performance rankings for each alternative. A similar comparative score was assigned for both environment and cost risk levels associated with each alternative investigated. The scores are weighted and normalized so that results of cost risk, environmental risk, and performance can be plotted. A simple Pareto Optimization was performed to show which alternatives were the best in the domains of cost risk versus performance, cost risk versus environmental risk, and environmental risk versus performance. Through Pareto Optimization, a trade-off was

performed to select the subsystem for each of the four cultivation stages. Having the trade-off analyses performed, the team was able to determine the recommended configuration from the alternatives investigated. The results of using this process for determining the HNAABS cultivation configuration is described in Section III.B.

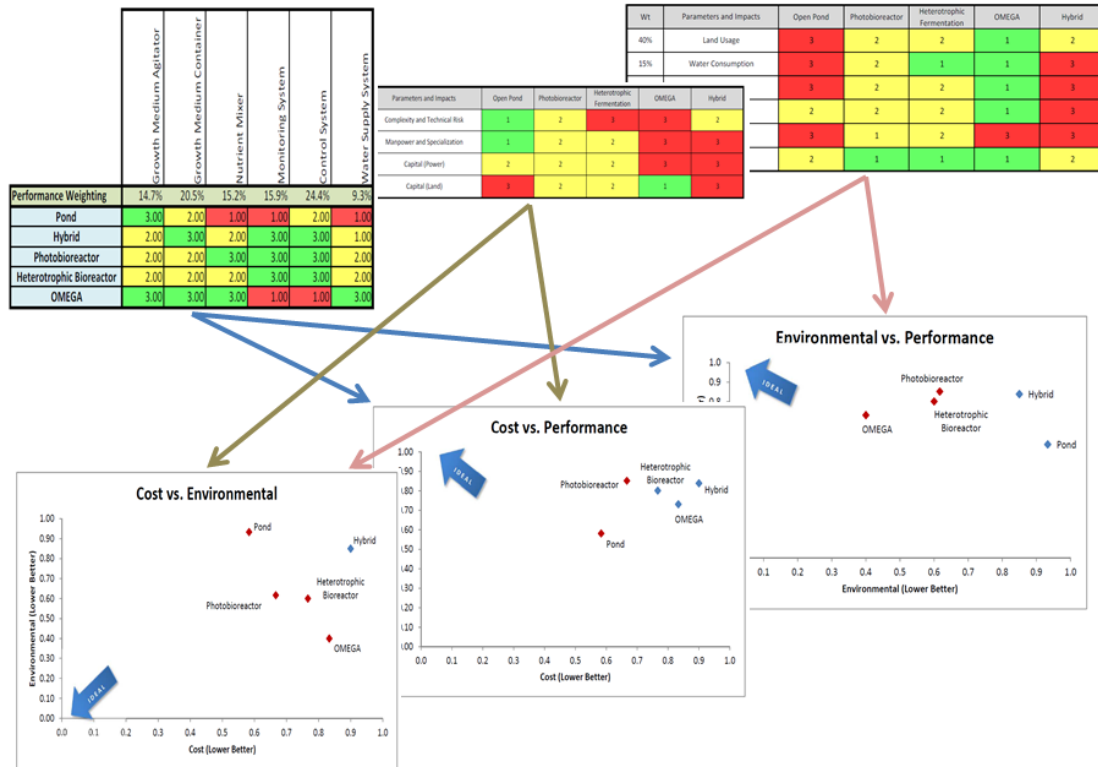

Figure 30. Performance, cost risk, and environment scoring to compare each alternative investigated. The results of these scores are weighted and normalized so that each of the three dimensions can be compared against each other in a simple Pareto Optimization for final trade-off selection.

**b. Refinement Analysis of Alternatives Method**

The refinement analysis of alternatives looked at three possible system configuration solutions for recommendation. The following alternatives were:

- Retrofitting an existing petroleum refinery
- Building a new bio-oil refinery
- Hybrid petroleum and bio-oil refinery

This alternative analysis process included a technical comparison of the benefits and drawbacks for all three alternatives. The analysis also determined the overall feasibility and complications compared with all the alternatives to recommend a final refinement configuration. A business case analysis was performed on the recommended refinement configuration. Figure 31 shows the analysis of alternatives flow to develop the business case analysis.

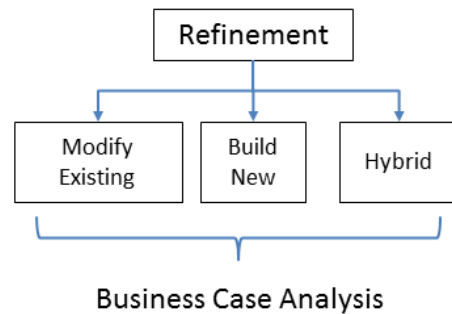

Figure 31. Refinement configurations analyzed. A business case analysis was performed for the different refinement options available for the HNAABS configuration.

## 2. Alternatives Selection Process

### a. Cultivation System Alternatives

To perform the cultivation analysis of alternatives, the top physical subsystems for each sub-function (growth, harvest, dewatering, and extraction) were identified using the comparison process. Table 1 presents the alternatives selected for detailed analysis. The physical subsystems were selected based on a combination of technical maturity, performance benefits, cost reduction, and/or environmental impact. A description of the methods and performance of each alternative is described in the next section.

Grow	Harvest
Pond	Centrifugation
Photobioreactor (PBR)	Microfiltration
Heterotrophic Bioreactor	Flocculation
Hybrid Pond and PBR	Decantation
Offshore Membrane Enclosures	Froth Flotation

Dewater	Extract
Fluidized Bed Dryer	Mechanical Expulsion
Conveyor Dryer	Chemical
Flash Dryer	Quantum Fracturing
Superheated Steam	Atmospheric Decompression
Rotary Dryers	

Table 1. Cultivation subsystem alternatives selected for each of the four cultivation stages. Five alternatives were chosen for each stage to keep the analysis process manageable (four for extraction). These alternatives were chosen based on a combination of general performance, cost, and technical maturity.

***b. Refinement System Alternatives***

The refinement system configuration alternatives were selected for their feasibility within the state of Hawaii. There is potential for retrofitting a current or dormant refinery within Hawaii making this a possible alternative. The other alternatives include a completely new refinery specifically for the use for the production of biofuel or adding to an existing refiner to make a hybrid system containing both bio and fossil refinement processes.

**B. CULTIVATION SYSTEM**

**1. Background**

***a. Process Description***

Figure 32 depicts the overall process of producing green crude oil to deliver to the refinery. In this case, the upper-right oval titled “High-Energy-Density Biofuels” is a precursor liquid that is able to be refined to JP-5 fuel specifications. Also, since cultivation is the first phase in the end-to-end biofuel production process, it is

critical that the size scale of the cultivation and associated processes are determined accurately (Darzins and Knoshaug 2011).

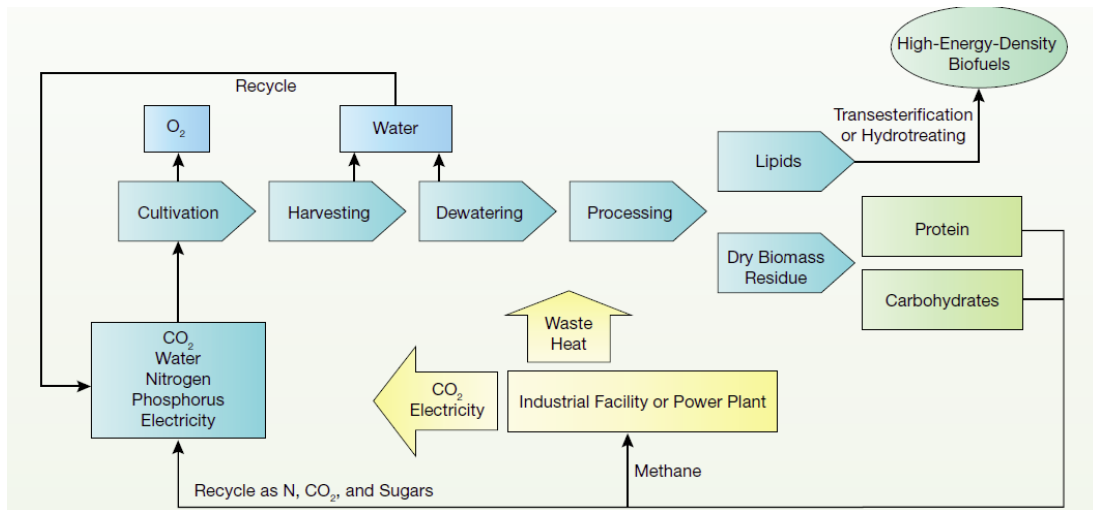

Figure 32. Algal biofuels process diagram. The cultivation system design was divided into the four stages of cultivation: growth, harvesting, dewatering, and extraction (From Darzins and Knoshaug 2011)

The growth phase begins by inoculating the growth medium with an initial set of algal biostock, that is then grown to a mature enough level that maximizes oil content. To grow the algae requires feedstock nutrients such as carbon dioxide, nitrogen, and phosphorus. If the algae strain is grown through heterotrophic means (i.e. without sunlight) the system also requires sucrose feedstocks for the fermentation process, otherwise sunlight or artificial light is required for the photosynthesis process.

Once the algae has grown to the harvestable level, a subsystem is required to perform the harvesting function where the algae is separated away from the medium it was growing in. The goal of this is to harvest as much algae culture as possible while reducing the amount of water removed from the growth medium.

The harvested algae culture then needs to be dewatered or dried to remove as much water content as possible leaving essentially only algae remaining. The dewatering process has the potential to be energy and cost intensive and is one of the critical factors in the way of algae-to-biofuel feasibility (Sheehan, et al. 1998).

Once the algae culture has been dried, or dewatered, the oils within the algae need to be separated. This process also has the potential to be energy and cost intensive, thereby greatly impacting the feasibility of this system (Sheehan, et al. 1998). The goal of this function is to maximize the amount of oil extracted from the algae while wasting as little oil as possible.

***b. Cultivation Scope***

The configuration of the cultivation system is defined as the cultivation (growth), harvesting, dewatering, and processing (extraction) functions within the overall biofuel production process. Once the oils have been extracted from the algae culture, the oils can be processed for use within the refinement system to be converted to biofuel.

The cultivation system is responsible for algal production to include the growth and harvesting of algae and the extraction of base oil products from the algae biostock. The amount of green crude oil produced from a given amount of biostock is dependent on a variety of factors. For example, certain algae strains are more resistant to climate effects, including temperature changes and amount of precipitation. This generally comes at a price, as the energy invested into the production of proteins and carbohydrates for robustness results in less energy available toward the production of oil (Raleigh and Kuehnle 2009). The first step in the cultivation process lies in choosing an algae strain that balances oil content and growth rate and can be paired with an efficient cultivation process that is compatible with that particular strain. Different algae strains have varying growth rates, oil yield, as well as oil composition (Herndon 1963). A baseline strain was selected for the HNAABS configuration so that baseline values can be used for modeling purposes.

To aid in the selection of the final cultivation system, the strain selection is initially constrained for the purposes of modeling and estimating performance output of the cultivation system. Two key requirements for the strain selection are that the strain is native to the Hawaiian ecosystem and that it is not genetically modified. The restriction to only native Hawaiian cultures is due to the ban of genetically engineered organisms in an open environment (Raleigh and Kuehnle 2009). The cultivation analysis chose

*Chlorella* as the general strain selected for use within all systems except OMEGA, which utilizes macroalgae (seaweed) as the growth culture. The choice for *Chlorella* as an algae strain comes from known and predictable production values for the growth and oil content of this strain within the Hawaiian environment. The selection of *Chlorella* was chosen from top recommendations in Laboratory and Large-Scale Screening and Production of Marine Algae in Hawaii for Enhanced Production of Algal Oils for Biodiesel and Other Biofuels (Raleigh and Kuehnle 2009). It is important to note that *Chlorella* was primarily chosen as a modeling value to help obtain key algal properties such as growth rate, oil yield, and surface-to-volume ratio of the algae to assist in energy, production, and cost estimates. Not only does the screening select *Chlorella* as a top choice for growth within Hawaii, the Natural Energy Laboratory of Hawaii Authority (NELHA) grew *Chlorella* in both photobioreactor and pond growth mediums for large scale studies (Raleigh and Kuehnle 2009). Thus, *Chlorella* should provide the HNAABS Project Team with representative values of growth rate, growth cycle, and oil yield of *Chlorella* when grown in Hawaii. The HNAABS project estimates can be modified given the properties of a different strain.

## **2. Growth Subsystem Alternatives Analysis**

An analysis of alternatives was performed on the growth portion of the HNAABS Cultivation System to recommend the best of alternative investigated. It was recommended that a photobioreactor algae growth system be used for the final configuration for HNAABS. The next sections describe the process that resulted in this recommendation.

### ***a. Scope and Background***

Growth is the first step in the cultivation process of a particular algae strain. In this portion of the cultivation system, algae is cultivated from some initial stock of algae and grown to an acceptable harvest level. Algae are considered harvestable when the organisms have reached either optimal oil-to-mass ratio or the point of maturity, where growth is at peak production, which is assumed to be 24 hours to double in concentration (Raleigh and Kuehnle 2009). There are variables that are not covered in

detail in this analysis, including algae strain selection and harvest decision criteria. This growth analysis of alternatives describes the process of evaluating the comparative cost, performance, and environmental impact/risk to determine the recommended systems to be integrated within the entire algae cultivation system. For this analysis, it is assumed that the entire system will be located in Hawaii and that an optimal strain is used for the respective growth method. For example, an ideal macroalgae (seaweed) is selected for Offshore Membrane Enclosures for Growing Algae (OMEGA) (described in Section III.B) or an ideal heterotrophic microalgae strain is selected for the heterotrophic bioreactors. A set of subject matter experts in the area of algae biology and biofuel engineering should selected the strain based on the cultivation configuration, the environment, and desired uses of the algae product. For the purposes of the report, *Chlorella* as mentioned in the previous section is the baseline strain for all processes except OMEGA.

A key element of the algae cultivation system is the type of algae culture strain(s) to be cultivated and harvested (Sheehan, et al. 1998). Though research has been done to investigate the best algae strain to use, this report does not describe the results of such strain selection research (Herndon 1963). There are reports detailing the best strains to select for cultivation within Hawaii and the best time during the growth curve to harvest the algae to optimize growth conditions for biofuel production (Raleigh and Kuehnle 2009). Due to time and resources, the scope of this report was limited to only the cultivation system and not the selection of the strain to be used. For the purpose of this analysis, the algae strain is assumed to be *Chlorella* as final strain selection would depend on all four subsystems of algae cultivation (growth, harvest, drying, and extraction) and not just the growth system. The selection of the optimal algae strain should be performed by a group of algae subject matter experts to maximize the performance and output of the entire cultivation system. Maximum performance of the growth system is defined to be the maximum rate of algal oil content that can be harvested from the cultivation system.

For the growth analysis of alternatives, five cultivation methods were chosen to go through the selection process and are described in detail in the next section. The five investigated alternatives for selection include:

- Open Raceway Pond (ORP)
- Closed Photobioreactor (PBR)
- Closed Heterotrophic Bioreactor
- Hybrid Pond and Bioreactor
- Offshore Membrane Enclosures for Growing Algae

A summary of each method is described in the next section. The five cultivation methods are considered, along with their advantages and disadvantages, and the best algae cultivation method is selected and described in this paper. The process is documented in the next section so that future adjustments may be made if performance, costs, or environmental updates are made in algae growth technology.

The growth analysis of alternatives section of the paper is limited to covering these five systems for the purpose of algae growth. The following analysis of alternatives will include algal bio-kerosene production through its many stages: growth and cultivation, harvesting, dewatering, lipid or oil extraction, refinement and conversion to biofuel, and the disposal and reuse of the leftover biomass.

Although the biodiesel production process is a system of systems, the focus of this AoA is the system of algae growth. Along with their advantages and disadvantages, the following sections discuss, in greater detail, the five cultivation methods investigated.

***b. Alternatives Investigated.***

There are different ways that researchers and scientists have cultivated algae for use as a biofuel source. The top five growth system choices were selected for an in-depth Analysis of Alternatives (AoA) to include the growth methods described in Table 2. These alternatives were identified due to their promise for feasibility on a large industrial scale. Many of the alternatives investigated have relatively large production facilities already existing in Hawaii such as the pond, photobioreactor, and hybrid alternatives. Other alternatives, such as the heterotrophic bioreactor and OMEGA, are relatively new growth processes that show promise and address the shortcomings and disadvantages of the other alternatives.

Method	Description
<b>Open Pond System</b>	Utilizes open-air raceways and constant agitation with paddlewheels within an aqueous solution of algae and nutrients.  <b>Example Current Companies or Research Groups with Facilities:</b> Seambiotic Ltd, Aquatic Energy, Aurora Biofuels, Cellana, General Atomics, Carbon Capture Corporation  System operated in Hawaii? <b>Yes</b>
<b>Photobioreactor System</b>	Utilizes sealed transparent growth chambers to provide a closed and controlled environment for growing algae.  <b>Example Current Companies or Research Groups with Facilities:</b> Cellana, Bodega Algae, Solix Biofuels, Diversified Energy (Simgae)  System operated in Hawaii? <b>Yes</b>
<b>Heterotrophic Bioreactor</b>	A fermentation tank growth process, where sunlight is not used for algal growth and a feedstock nutrient (sugar) is utilized instead.  <b>Example Current Companies or Research Groups with Facilities:</b> Solazyme, Inc.  System operated in Hawaii? <b>No (but planned)</b>
<b>Hybrid Open Pond System and Photobioreactor</b>	Utilizes a combination of photobioreactors and open pond systems in phases to balance the benefits of both systems.  <b>Example Current Companies or Research Groups with Facilities:</b> Cellana, Cyanotech  System operated in Hawaii? <b>Yes</b>
<b>OMEGA (Offshore Membrane Enclosures for Growing Algae)</b>	A NASA developed alternative (in partnership with the U.S. Navy) which consist of transparent membranes (containing algae cultures) that float on the surface of the ocean.  <b>Research Facilities:</b> NASA  System operated in Hawaii? <b>No</b>

Table 2. Description and of algae growth methods investigated showing list of companies or research groups with each method. Note that all methods but OMEGA have been or are planned to be utilized in Hawaii.

Many companies and research institutes have constructed cultivation facilities for the purposes of biofuel production. It is important to note that most of these facilities are research based and not the size required by the HNAABS cultivation systems to generate millions of gallons of oil per year. However, many studies have been performed to address the feasibility of such large scale systems by extrapolating the results of the smaller facilities to the scale of an industrial sized facility required for the HNAABS cultivation system in Hawaii (Sheehan, et al. 1998). The performance of the

alternatives investigated is either extrapolated or estimated from performance results from these smaller cultivation and lab facilities.

Table 3 describes the advantages and limitations of both the pond and various forms of photobioreactor systems. The details of both pond and photobioreactor systems will be described later in this section.

Production System	Advantages	Limitations
<b>Raceway Pond</b>	Relatively cheap Easy to clean Utilises non-agricultural land Low energy inputs Easy maintenance	Poor biomass productivity Large area of land required Limited to a few strains of algae Poor mixing, light, and CO <sub>2</sub> utilization Cultures are easily contaminated
<b>Tubular Photobioreactor</b>	Large illumination surface area Suitable for outdoor cultures Relatively cheap Good biomass productivities	Some degree of wall growth Fouling Requires large land space Gradients of pH, dissolved oxygen and CO <sub>2</sub> along the tubes
<b>Flat-plate Photobioreactor</b>	High biomass productivities Easy to sterilize Low oxygen build-up Readily tempered Good light path Large illumination surface area Suitable for outdoor cultures	Difficult to scale-up Difficult temperature control Small degree of hydrodynamic stress Some degree of wall growth
<b>Column Photobioreactor</b>	Compact High mass transfer Low energy consumption Good mixing with low shear stress Easy to sterilize Reduced photoinhibition and photo-oxidation	Small illumination area Expensive compared to open ponds Shear stress Sophisticated construction

Table 3. Advantages and limitations examples for growth systems (After Brennan and Owende 2009).

(1) **Open Raceway Pond (ORP) System.** One of the most prevalent systems of algae cultivation has been the open pond method. Natural systems (such as ponds, lagoons, and lakes), artificial ponds, and man-made containers accommodate this method. The most common pond system utilized is the raceway pond. An initial, high quality, controlled set of algae stock is introduced into a loop-shaped channel. After being mechanically aerated with CO<sub>2</sub>, the algae culture completes the loop. At the end of the cycle, the blend is harvested before the succeeding cycle begins. The recirculation channels are normally between 0.2-0.5m deep. There is a limitation to the depth allowed as light is unable to effectively reach any deeper to aid in algae growth.

Raceway ponds are built with concrete pools, though other variations can include compacted earth lined ponds with plastic moldings. There are many intricacies of the algae production cycle. At the beginning, the initial algae stock and nutrients are introduced at the pond's paddlewheel. The paddlewheel also acts as a filter to prevent sedimentation and is always in continuous operation. The surface air surrounding the ponds provide the algae with much of its CO<sub>2</sub> content, however, aerators which are submerged in the pond increase CO<sub>2</sub> absorption (Algae Energy 2013).

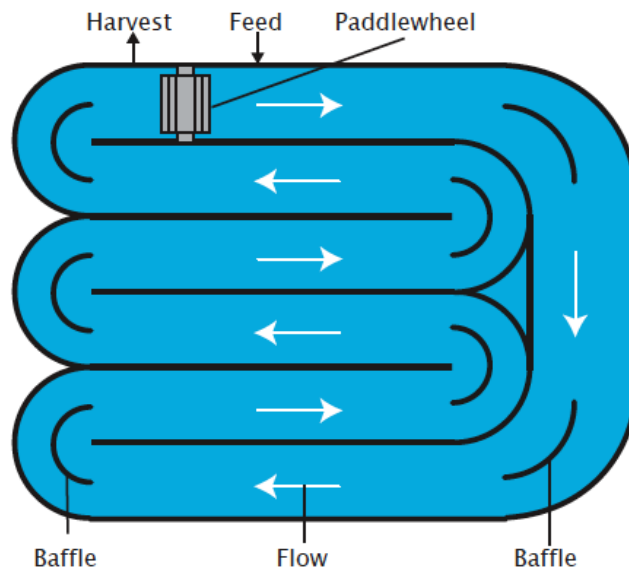

Figure 33. Open raceway pond system showing the growth process and flow (From Algae-Energy 2013).

Compared to new technologies, such as closed photobioreactors, the pond method is considered to be the cheapest large scaled algae cultivation method. Many factors contribute to the burdened cost effectiveness of the method. The open pond algae production method does not require soil or fertile land, thus there is no competition with existing agricultural crops for usable land. The pond system can be implemented in areas where there is a low potential of crop growth, such as on top of the thousands of acres of hard rock lava fields that exist in Hawaii. The pond method is also considered to be energy efficient. The energy input requirement for pond cultivation is much lower than new methods. Regular maintenance and cleaning of the system is also quite simple. Due

to these factors, overall, the pond method has high potential for large net energy production. The pond algae cultivation method is the least expensive method in biofuels science of all the other alternatives investigated. However, even the pond system suffers from questions on the economic feasibility of this method (Brennan and Owende 2009).

Additionally, the open pond system has its disadvantages. The required environments can be highly restrictive due to the threat of pond contamination and pollution. Other algae species and protozoa are the primary culprits of pond contamination. When compared to closed photobioreactors, the pond method is considered less efficient. Factors attributing to the lower productivity include evaporation losses, temperature fluctuation in the growth media, deficiencies in CO<sub>2</sub>, inefficient mixing, and light limitations. Evaporation is unavoidable since the pond system is completely open to the environment. The evaporation of water from in the pond system results in significant changes to the composition of the growth medium and can lead to detrimental effects to the algae growth. Temperature fluctuations are also difficult to mitigate with the pond system. Seasonal temperature variations occur and this can impact the availability of CO<sub>2</sub> in the surface air. Atmospheric diffusion associated with temperature change reduces the available CO<sub>2</sub> and results in reduced biomass productivity. The stirring mechanisms within the pond method are paramount. Poor agitation of the growth medium can result in less than desirable CO<sub>2</sub> nutrient transfer rates, also causing low productivity. Light limitation due to top layer thickness as the algae grows may also incur reduced biomass productivity. Light supply can be enhanced by limiting the thickness of the top layer of algae and minimizing the depth of the growth pond (Brennan and Owende 2009). Figure 34 shows an aerial view of the Kauai Algae Farm in Hawaii utilizing a form of the open pond system.



Figure 34. Aerial view of the open pond system (pond system on right, power plant on left) utilized at the Kauai Algae Farm (From Hawaii Congress of Planning Officials 2012).

According to the Solar Energy Research Institute, it was estimated that the cost to produce a 42 gallon barrel (bbl) of algae lipids was \$62. SERI also found that growth rates for an economical pond system were roughly  $30 \text{ gm/m}^2/\text{day}$  but could have huge variation depending the factors described above (depth, lighting, temperature, algae strain) (Goebel and Weissman 1985).

(2) **Closed Photobioreactor System.** A photobioreactor (PBR) is a closed system that provides a controlled environment and removes many of the external influences present in an open system. As PBR is a closed and controlled system, the growth of algae can be optimized to the requirements provided by the growers. Inputs into the system that need to be controlled, in addition to the purity of the culture itself, are  $\text{CO}_2$ , water, temperature, exposure to light, culture density, pH levels, gas supply rate, and mixing method system. Figure 35 describes the simplified process for a photobioreactor system.

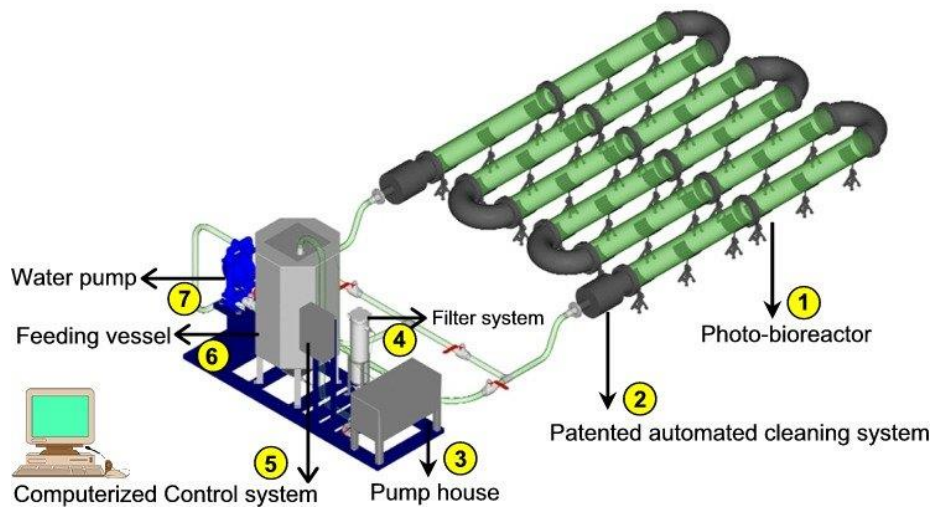

Figure 35. Process flow for photobioreactor systems(From ReThink Factory 2013).

As shown in Figure 35, the photobioreactor (1) works by providing a controlled amount of light, water, and nutrients to the algae. Inputs are controlled (5) and put into the feeding vessel (6). From the feeding vessel, the flow goes to the pump (7 and 8) which controls and moderates the flow of algae into the tube. The CO<sub>2</sub> inlet valve is built into the pump. The PBR is used to promote growth by controlling the environmental parameters (inputs) including light. PBR tubes are typically made of acrylic and designed to have dark and light intervals to enhance growth rate. A PBR system usually has a built-in cleaning system (2 and 4) that cleans the tubes internally without halting production.

After the algae have completed the flow through the PBR, it passes back to the feeding vessel. As it passes through the hoses (shown in Figure 35), the oxygen sensors determine how much oxygen has built up in the plant and the oxygen is released in the feeding vessel. Oxygen built up within the photobioreactor is an issue the pond system does not have to deal with since the pond system is open to the environment. If oxygen is not taken out of the system (typically released to the environment naturally in a pond system), then the oxygen will inhibit growth and even poison the algae (Wen and Johnson 2013). The optical cell density sensor determines the harvesting rate at this stage. The algae will pass through the filtering system once it is ready for harvesting. The

filter will collect the algae that are ready to be processed while the rest is sent back to the feeding vessel and this cultivation cycle is continuously performed.

A key element of the photobioreactor system is that the environment can be better controlled to a tighter tolerance than an open system like the pond growth method. The increased controls provide increased growth potential. The higher control typically results in large surface-to-volume ratio of the harvested algae compared to the open pond system. The photobioreactor system allows light penetration from multiple angles than just the top surface in pond systems. Also, the improved agitation of the photobioreactor system allows all of the algae to receive the same amount of insolation (light exposure). The high controls also allow for better control over gas transfer, less evaporation of growth medium, and more uniform temperatures. The closed nature of the system provides protection from external contamination (Mulumba 2012). The higher growth density allows better space savings compared to a pond system. PBR systems with automatic cleaning are able to reduce fouling of the growth medium.

An alternative to the PBR occurs when the open raceway pond is covered. Covering the open raceway pond offers some of the benefits of the PBR, but the PBR still provides better control of inputs (temperature, light, gas transfer). A PBR system will improve algal biomass production by keeping the genetics pure and reducing the risk of parasite infestation (Oilgae, Cultivation of Algae in a Photobioreactor 2012).

According to the Sustainable Energy Research Center at Utah State University, a drawback of the photobioreactor system is that the initial capital costs typically exceed that of a standard pond system. However, the production improvements of the photobioreactor over the pond system provide much higher oil production per operating costs. The final biomass output rates and costs compared to the pond system have not been determined to be dramatically better than the pond system. (Zemke, Wood and Dye 2008)

(3) **Closed Heterotrophic Bioreactor System.** There is an alternative to the closed-bioreactor system that does not include the requirement for sunlight, and this is the sugar fed heterotrophic bioreactor system. The heterotrophic bioreactor system is sometimes referred to an algae fermentation tank system. This is a

variation of the closed-container process that utilizes fermentation. The algae are cultivated in a closed system and fed sugar to provide growth of algae. This method allows for large productivity since all environmental factors can be controlled and moderated to a high degree. This process also allows for the algae to be grown anywhere in the world independent of atmospheric weather conditions.

One company using this method is Solazyme Inc.; an alternative energy company based out of San Francisco, CA. Solazyme Inc. has developed a new method to grow algae within fermentation tanks for the purposes of biofuel production. The algae are fed renewable plant-based sugars. Solazyme Inc. states this method could lead to a less expensive biofuel (Grant 2009). The company proved this technology by demonstrating its use in a diesel car and then announced a development agreement with Chevron. The company received a 2 million dollar grant from the National Institute of Standards and Technology (NIST) to develop this algae-based biofuel (Solazyme, Inc. 2009).

This process combines genetically modified strains of algae with an alternative approach (not using sunlight, but using sugar) to grow algae and to reduce the cost of producing this biofuel. The algae are grown in the dark inside stainless steel containers. The research on this technology shows that when algae are fed sugar, the organisms convert it into various types of oil. The oil is then extracted and processed to make a range of fuels that include diesel and jet fuel. Unfortunately, genetically modified strains of algae are deemed to offer too great of an environmental risk and are not permitted in or around the Hawaiian Islands (Raleigh and Kuehnle 2009).

This process' distinct advantage over the other systems is that it does not require the photosynthesis process and therefore lacks the need for sunlight. This means that the system can run at all times regardless of weather or time of day and operate 24 hours and 7 days a week. In the other systems (PBR and Open Pond), the algae are grown in ponds or bioreactors where they are exposed to sunlight and make their own sugar through photosynthesis. In the heterotrophic fermentation method, growers deliberately turn off the photosynthesis process by growing the algae in the dark. Instead, the algae get energy from the sugar that is being fed into the system. Another

important factor in the sugar fed system is that it is possible to grow them in concentrations that are orders of magnitude higher than when they are grown in ponds using sunlight. This is because sugar provides a concentrated source of energy. The higher concentrations reduce the amount of infrastructure needed for production, and make it much easier to harvest, dewater, and extract the oil, which in turn reduces cost.

The heterotrophic bioreactor system is meant to address the issue of cost feasibility for industrial scale growth. Studies such as the Aquatic Species program have already highlighted that the pond and photobioreactor systems (along with their harvest, drying, and extracting methods) are not feasible yet for commercial and industrial scale usage (Sheehan, et al. 1998). Since the publication of the Aquatic Species program in 1998, advancements with heterotrophic bioreactors may provide the improvements necessary to allow for feasible algae growth on an industrial scale required by HNAABS. For example, the California Energy Commission, with partnership from Solazyme Inc., has just recently begun the necessary research in 2012 to develop a heterotrophic bioreactor system for large scale uses (California Energy Commission 2012). This growth method is still in early development with few independent studies on growth and cost data for a large scale heterotrophic bioreactor facility.

(4) **Hybrid Open Pond and Photobioreactor System.** Most algae do not grow simultaneously by cell division and lipid accumulation. Generally they are mutually exclusive measurements of productivity (Ryan 2009). Therefore, achieving a high oil-to-mass ratio may involve increasing the algal culture concentration first, then increasing the lipid accumulation in a two-step process. With this approach, the first step seeks to maximize the reproductive processes of algae, allowing them to multiply as much as possible to increase the number of cells available to produce and retain oil. In the second step, the algal cells are then encouraged to produce as much lipid content as possible, thereby increasing the overall oil yield.

This two-step “hybrid” solution involves combining a closed photobioreactor (PBR) growth system with an open pond system. The closed PBR is used to inoculate the algal culture – large amounts of nutrients are supplied to the culture in the PBR chambers, which promotes cell division and minimizes contamination (which

should reduce culture attrition and invasive species encroachment). After the inoculation period, the algae is pumped out of the PBR and introduced into open pond raceways. Nitrogen supply is intentionally limited in the open ponds; nitrogen starvation in algae forces them to accumulate lipids “as a result of the lipid-synthesizing enzymes being less susceptible to disorganization than the enzymes responsible for the carbohydrate synthesis, so that the major proportion of carbon is bound in lipids.” (Becker 1993). The hybrid system is utilized by Cellana as an algae farm demonstration facility in Kona, Hawaii, shown in Figure 36.



Figure 36. Algae farm demonstration facility in Kona, Hawaii utilizing hybrid growth method with photobioreactors (right) and open pond systems (left) (From Cellana 2013).

A functional flow diagram of the hybrid growth method is shown in Figure 37. Note that the amounts of illumination utilized in Steps 1 and 2 are different: a 24-hour illumination period is utilized in the PBR, which maximizes algal growth potential by stimulating photosynthesis round-the-clock, while the open ponds rely on daylight patterns. This means that artificial light will need to be supplied to PBRs during nighttime or when sunlight levels are not sufficient (e.g., cloudy).

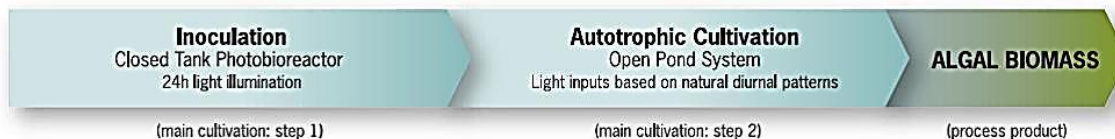

Figure 37. Hybrid cultivation system functional flow (From Ryan 2009).

Such hybrid systems can potentially address the limitations of either closed PBR or open pond systems while providing a large amount of lipid-rich biomass for harvesting (Ryan 2009). For example, attrition rates can be controlled in the initial (and often critical) inoculation phase – a closed PBR offers a highly controlled and contained environment that limits exposure to invasive algae species and allows control over nutrient ratios that can promote optimal rates of algal growth and reproduction. Also, the usage of open ponds to sustain the lipid-production stage in the algae’s lifecycle offers reduction in infrastructure and operating costs (when compared to a system where PBRs are used exclusively). Furthermore, separating the cultivation of algae into two distinct phases allows for optimization of both the cell division and lipid accumulation processes in different subsystems without interfering or restricting each other (they are mutually exclusive, requiring different parameters).

However, such hybrid systems can also suffer from the same disadvantages that are present in either PBR or open pond systems. Additionally, the costs involved in building and operating these hybrid systems are more expensive than the least costly alternative (i.e., exclusive open pond systems).

(5) **Offshore Membrane Enclosures for Growing Algae (OMEGA).** OMEGA is a relatively new development in algae growth research. With limited land resources available, NASA (in collaboration with the United State Navy) began looking at methods of growing plants for biofuel on the ocean surface. The goal of the research is to develop a commercially viable solution to producing algae at the levels that the U.S. Navy requires (10-20 billion gallons of oil) (NASA URS 2010). All previously discussed methods grow microalgae cultures. This system, instead, grows macroalgae (seaweed) on the open ocean. In this growth facility, the seaweed would be grown in membranes that are floating on the surface of the ocean (Figure 38).

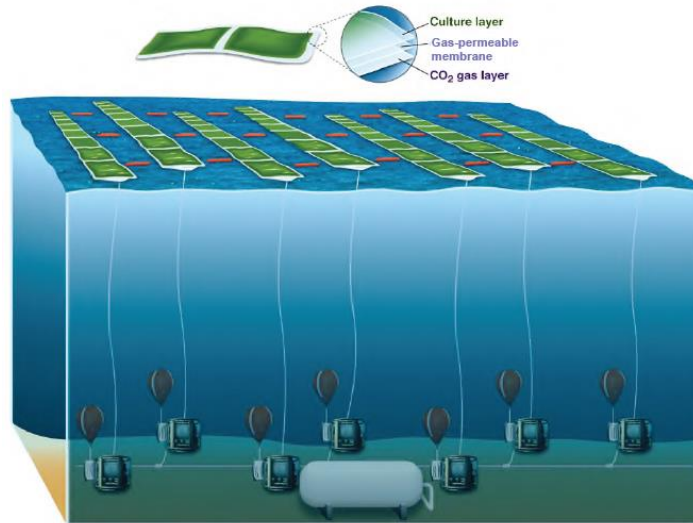

Figure 38. OMEGA growth facility (From J. Trent, OMEGA For the Future of Biofuels, 2010).

The membrane would be laid out by ships and initially inoculated with the desired macroalgae culture. This type of system is comparable to photobioreactors, except that they float on the surface of the ocean and do not require land resources. The membrane would be permeable to gasses but impermeable to the outside ocean layer to prevent spillage. For photosynthesis, the membranes would float on the surface of the water and have access to sunlight. Floating membranes are necessary so the seaweed would get as much direct light as possible. For nutrient supply, the offshore membrane system must be close to some resource such as a powerplant, agricultural waste facility, or waste water treatment facility. Pipes from the resource facility to the offshore membranes would provide the nutrients required to help grow the algae. When the algae has reached a harvestable state, ships will collect the membrane strips to be drained of their algae content, which would then go on to the dewatering, drying, and extraction processes (J. Trent, Offshore Membrane Enclosures for Growing Algae (OMEGA): A System for Biofuel Production, Wastewater Treatment, and CO<sub>2</sub> Sequestration 2010). Figure 39 shows the system as laid out on the ocean surface with feed supplies from the surface running along the ocean floor and up to the growth membranes.

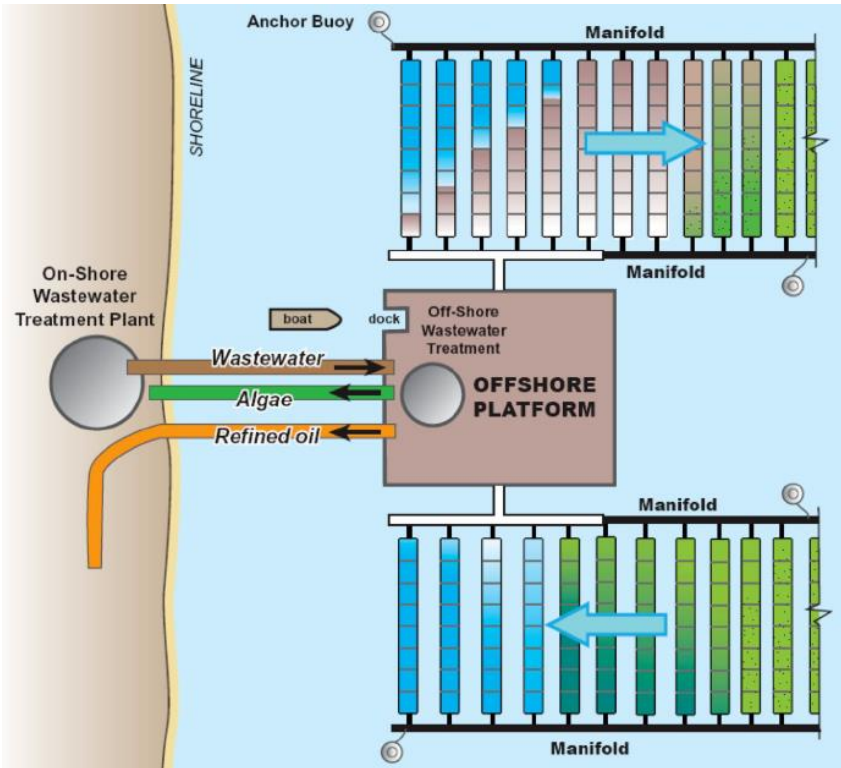

Figure 39. Concept of operations for the OMEGA facility (From Austin 2010).

An OMEGA growth facility could be mingled with offshore wind generation facilities where the sea surface is no longer used for standard navigation or fishing but has space to place OMEGA membrane strips. OMEGA is also promising for locations such as Hawaii, where land resources are valuable and of limited availability due to the varied terrain, cultural concerns, and regulatory limitations described in Section IV. Additionally, placing the system within a reef could reduce the risk of damage due to ocean swells, waves, and tides. The benefits of the OMEGA system are that it does not compete with valuable agriculture resources such as land, freshwater, and fertilizer and can actually provide resources to the agriculture industry.

Other key components of OMEGA are the lack of controls and power requirements to operate the growth facility. No temperature or environmental controls are needed as the natural ocean environment is suitable for macroalgae growth. There is no mixing system for the nutrients required as the wave action of ocean performs the tasks of mixing the nutrients with the algae cultures. Currently, NASA (in partnership

with the United States Navy) operates prototype facilities where they are developing membrane systems within large pools, but have yet to go offshore. Figure 40 shows an artist rendering of various design alternatives for the OMEGA system using either linear flow (like the pond systems) or mixed (like photobioreactors).

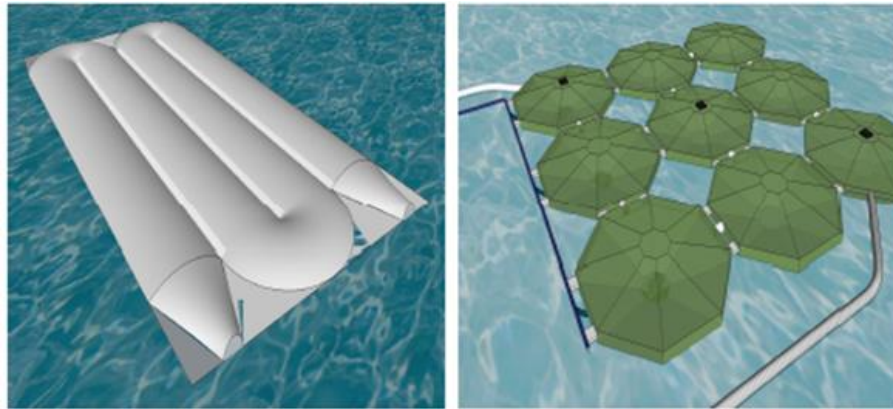

Figure 40. Initial OMEGA design alternatives (From NASA URS, 2010).

The OMEGA method is in early development, yet the different approach to growing algae on the ocean provides interesting benefits and concerns over a land-based growth system. Some of the other concerns are the scalability and feasibility of the system to be commercially and economically viable. There have also been no detailed environmental studies performed to ensure that the wastewater supply and the membranes do not impact local ocean habitats. There are also myriad logistical concerns such as the infrastructure and manpower required to operate a large OMEGA facility.

### *c. Environmental Considerations*

Overall, across the five Growth subsystem alternatives, the largest environmental consideration is whether or not the candidate system is open to the environment. Open Pond and Hybrid systems are exposed to the local environment, whereas the PBR and the OMEGA system are considered closed although the OMEGA membrane is semi-permeable to the ocean (J. Trent, Offshore Membrane Enclosures for Growing Algae (OMEGA): A System for Biofuel Production, Wastewater Treatment, and CO<sub>2</sub> Sequestration 2010).

The environmental aspects of the design alternatives were assessed according to their impacts on Hawaii Land, Water, Energy, Ecosystem, and Air. The Environmental Team assigned a value of 1 (Low Impact), 2 (Moderate Impact), or 3 (High Impact) to each parameter for each method and provided the scoring to the cultivation team to support the analysis of alternatives process. The results of this analysis and how it is integrated into the alternative selection process are described in the next section.

In this analysis, the cultivation method with the lowest environmental impact was the OMEGA method due to its low land use. The next lowest environment impact was the PBR which requires some land use, but less when compared to the open pond method. The theoretical maximum production per year-acre for the open pond method is 4,200 gal/yr-acre. The maximum production per year-acre for the PBR is 9,300 gal/yr-acre for algae biomass (Zemke, Wood and Dye 2008). Due to the cost impacts of leasing Hawaiian land, improvements in production density can greatly reduce the total cost of the cultivation system. These two methods (OMEGA and PBR) should be considered when trying to minimize the environmental impact during the cultivation process.

The following section describes the general benefits, concerns, and unknowns of the cultivation systems derive from a study authored by Catie Ryan called “Cultivating Clean Energy.”

(1) **Open Raceway Pond System.** The ORP has few benefits when compared to the other system alternatives. ORP can utilize industrial CO<sub>2</sub> emissions to simultaneously improve algae productivity and manage industrial waste gases. It also requires lower energy inputs and resources when compared to the other alternatives (Sheehan, et al. 1998).

Although there are benefits of using the ORP, there are also some concerns that could pose a risk to the environment. The ORP system requires specific growth conditions, such as high salinity, that could impact the quality of the environment in that local area. The major concern for an area like Hawaii is that ORP requires a large amount of flat land for production. The ORP method requires the use of the most land

(least-land efficient method). Another land concern of the ORP method is the additional requirement of a downstream pond for algae maturation and sediment settling. This transformation of the landscape to meet the aforementioned land requirements can alter native habitats and the ecosystem.

Some other major concerns for this method include:

- High evaporation rates
- Pond overflow
- Pond contamination

There are major unknowns that need to be taken into account in this process. There are long-term implications of the major land transformation required for an open pond system could have unknown impacts (Chillingworth and Turn 2011).

(2) **Photobioreactor (PBR).** There are potential benefits of the PBR system over the open pond system that can be utilized to ease environmental concerns as well as mitigate environmental risks in this process. Like the ORP, recycled CO<sub>2</sub> emissions taken from a waste treatment facility or power plant can improve algae productivity. The largest benefit to an area like Hawaii is the minimized impact to regional land use and natural habitats and the decreased land transformation that is required for the open pond system. Compared to the ORP, the PBR uses less land.

There are some concerns for this process as well. For a large scale production facility, an efficient light delivery and distribution can be principle obstacles. Also, energy demand may be an initial challenge for commercial scale purposes. The photobioreactor fabrication material components may carry heavy metals that could impact soil and water quality when used, recycled, or disposed.

There are some unknowns involved with the PBR process. Like the ORP, the water use data is limited and sometimes inconsistent. There are major implications of energy demand that need to be addressed. There are very few large-scale PBR systems that have been implemented, so large scale environmental impact is difficult to ascertain.

(3) **Heterotrophic Bioreactor.** There are some benefits of the Heterotrophic Fermentation (Bioreactor) method. First, there is minimized water usage

and management. Also, there is minimal usage of energy inputs due to high cell densities, low water content, and no light usage. There is also reduced landfill by use of waste glycerol and other sugar fed “wastes” such as switch grass, sugarcane, sugar beet, and low-grade molasses. This method is applicable in most climates and has a limited impact on land use (Solazyme, Inc. 2009).

The main concerns of this process focus on the feedstock source. Indirect water inputs depend on the feedstock so this could shift the water burden to the cultivation of the feedstocks on arable land. The indirect water inputs could be high if feedstock is derived from an irrigated crop. The feedstock could be limited by seasonal availability based on scalability of the cultivation plant.

The unknowns of this process are based on the limited knowledge of this new method. There is no data on the energy balance and that includes the indirect water inputs. Like the other methods, water use data are limited. There are potential environmental costs and benefits with the high quantities of soluble carbonate inputs with some sources being more sustainable than others.

(4) **OMEGA.** There are unique benefits associated with OMEGA. The main benefit is that it is used offshore which means it requires little land use to support cultivation. Also, there is little to no freshwater required as the growth medium is the natural ocean environment. Since it is offshore, there are minimal threats to the air or soil quality. The process uses minimal energy due to the natural agitation of the ocean that performs the nutrient mixing and aids in culture growth (J. Trent, OMEGA For the Future of Biofuels 2010).

There are very few known concerns with OMEGA. If the OMEGA cultivation site is not located near support facilities, the transportation from the ocean surface to land would be an issue. OMEGA takes advantages of waste output from facilities such as a waste management facility or power plant for nutrient input. These supply lines would run along the surface of the ocean. A failure of these supply lines could be a risk to the local environment.

The major unknown of OMEGA is that it is a new technology with little environmental impact information available. The data is limited for water use and transportation.

(5) **Hybrid Pond and Photobioreactor.** The hybrid system utilizes a combination of the ORP and the PBR systems. This allows high control for the initial growth phase with cheaper large scale growth for the ending phase of growth. It also shares the same environmental benefits as the two separate ORP and PBR. It also has an improved land efficiency compared to the open pond system. If there is a vertical arrangement and increased area for natural sunlight, it could make some outdoor PBR systems within the hybrid more land efficient (Obbard 2011).

The hybrid system shares some of the environmental concerns of the ORP and PBR systems. This system is more land efficient than the ORP but still not as efficient as the PBR. Like the other systems that are exposed to open air, there are evaporation rate concerns that could impact water demand and humidity levels. Like all systems, there is a concern accommodating wastewater.

The environmental unknowns of the hybrid system are similar to both the PBR and ORP systems. There are long-term implications of large land transformations that may be required to support the pond portion of the hybrid system.

#### *d. Scoring*

A detailed numerical analysis of alternatives was performed on the growth subsystem to determine, as objectively as possible, the top method given the prioritization scores described in the next section. This process follows the previously described Analysis of Alternatives process in Section III.A.1, with the individualized scoring described in the following section. For this analysis, we score the requirements by priority and map them to the design characteristics of the system, then to functions, and finally to physical subsystem allocation. A final performance weighting is calculated along with a comparative analysis of the cost and environmental impact of each alternative. For the final comparative performance weightings, the British Columbia Innovation Council developed a list of advantages and disadvantages for each system

(Alabi, Tampier and Bibeau 2009). The OMEGA system performance parameters had to be estimated based on advertised performance expectations due to the low technical maturity of the method as only predicted performance results are available. For the cost aspect of OMEGA, it is given a high risk score (explained in the results) since there is little to no large scale cost analysis available for this method.

An analysis of the results in the aspects of cost, performance, and environmental is then performed to provide a final recommendation of the selected growth system. It is important that this systems engineering decision analysis looks at cost and environmental risk as separate variables from performance. Therefore, no cost aspects will be discussed when describing the performance of the system. The final comparative performance will be compared to cost and environmental risk to demonstrate an objective selection process for the growth method used in the full HNAABS configuration.

The next sections describe, in detail, the decision analysis process utilized to walk the reader through the process. This process can be utilized by other groups with different priority and interaction scoring to yield different results. This will be particularly useful as technology and performance in algae growth improves over time or if stakeholder priorities shift.

(1) **Requirements Prioritization.** To support stakeholder key priorities, each member performed a priority scoring from the perspective of the stakeholder. Typically, in this process the scoring would be performed by the stakeholders to assist in the decision process. Due to the project timeline and the process involved when working with the NPS Internal Review Board (IRB) in regards to surveys, it would have been prohibitively difficult to obtain scores from actual stakeholders. Instead, each team member provided justification for his or her scoring from the viewpoint of a key stakeholder. The team met and resolved any scoring discrepancies and provided reasoning for the final scoring. Table 4 shows the final, compiled, requirements priorities scoring. The scoring values used were chosen based primarily on the intended environment the growth system will be installed in Hawaii and the purposes that drive the HNAABS project (energy security and sustainable energy). The results shown in Table 4

are an example of scores and can be modified by stakeholders if priorities differ from the example provided. This process is described in sufficient detail to be reusable. This method of scoring requirements priorities is tailored for the HNAABS project and derived from the analytic hierarchy process (Triantaphyllou and Mann 1995) as well as concurrent engineering decision analysis (Blanchard and Fabrycky 2010). Since this decision analysis step looks only at the performance aspect of the growth system, there are no costs or environmental priorities shown. The cost and environmental trade-off is performed in the results section.

Item	Priority Score									Item
Maximize Algae Growth	9	7	5	3	1	3	5	7	9	Minimize Use of Manpower
Maximize Algae Growth	9	7	5	3	1	3	5	7	9	Minimize Land/Ocean Surface Use
Maximize Algae Growth	9	7	5	3	1	3	5	7	9	Minimize Power Consumption
Maximize Algae Growth	9	7	5	3	1	3	5	7	9	Minimize Waste Generation
Maximize Algae Growth	9	7	5	3	1	3	5	7	9	Minimize Distance to Resources
Maximize Algae Growth	9	7	5	3	1	3	5	7	9	Collect Resellable By-Products
Maximize Algae Growth	9	7	5	3	1	3	5	7	9	Minimize Water Consumption
Maximize Algae Growth	9	7	5	3	1	3	5	7	9	Maximize Oil Content to Mass Ratio
Maximize Algae Growth	9	7	5	3	1	3	5	7	9	Minimize Nutrient Consumption

Table 4. Customer prioritization results showing heavy leaning of priority to maximize algae growth output over other priorities. Note that this scoring signifies that being able to collect sellable by-products and minimizing power consumption are just as important as maximizing algae growth.

For each priority factor in Table 4, a score of 1, 3, 5, 7, or 9 is used to signify relative importance. The higher value to the left signifies higher importance on the left priority (Maximize Algae Growth) and the higher value to the right signifies higher important to the additional priority factors on the right. It is important to understand that in this initial scoring, the score only signifies preference toward one property on the right being more or less important than the baseline priority factor (Maximize Algae Growth). The scoring is based entirely on stakeholder preference. For example, in the first row, the team gave a score weighting of 7 in favor of algae output as compared to the importance of reducing the amount of manpower required. This indicates that the team believes a gain in relative algae growth is worth seven times as much as a

decrease in manpower. An example of different priority could be in land and ocean surface use. It could be possible that a stakeholder actually highly prefers to minimize land and ocean surface use above all the baseline priority (Maximize Algae Growth). In that event, the stakeholder would score on the right side of Table 4, asserting greater relative value to minimizing land resources the farther (higher numerically) right the stakeholder chooses for their final score.

This step is the initial key weighting that gets pulled into the Pairwise comparison matrix described in the next section to determine exactly how each requirement compares to the other instead of just to the baseline performance item (in this case Maximize Algae Growth). For the example scoring, Maximize Algae Growth is high on the estimated stakeholder priority list.

(2) **Pairwise Comparison Matrix.** The final results of comparing each key performance criteria to another can be seen in Table 5. This allows the team to calculate relative priorities from the initial priority scorings. This pairwise comparison matrix method is derived from Systems Engineering and Analysis (Blanchard and Fabrycky 2010). This matrix is constructed by putting the numerical scores in the previous section along the first row of the matrix. These scores are the relative importance from all other priorities to the baseline priority (Maximize Algae Growth). If a non-baseline priority was scored at higher importance than the baseline priority, then the matrix would have the inverse of the score in the first row. For all other cells in the top-right section of the matrix, the value shown is calculated by using the baseline scores in the first row and comparing the two baseline values to each other. For example, the matrix shows that minimizing power consumption is scored 3 times higher than minimizing water consumption. The diagonal portion of the matrix is all 1's since a given factor is the same importance when comparing it to itself. The bottom-left portion of the matrix is simply the inverse of the relative priorities calculated in the top-right (i.e. if choice A is 5 times as important as choice B, choice B is one fifth as important as choice A). This matrix provides a quick way to take a simple priority scoring in the previous section, and determine overall importance.

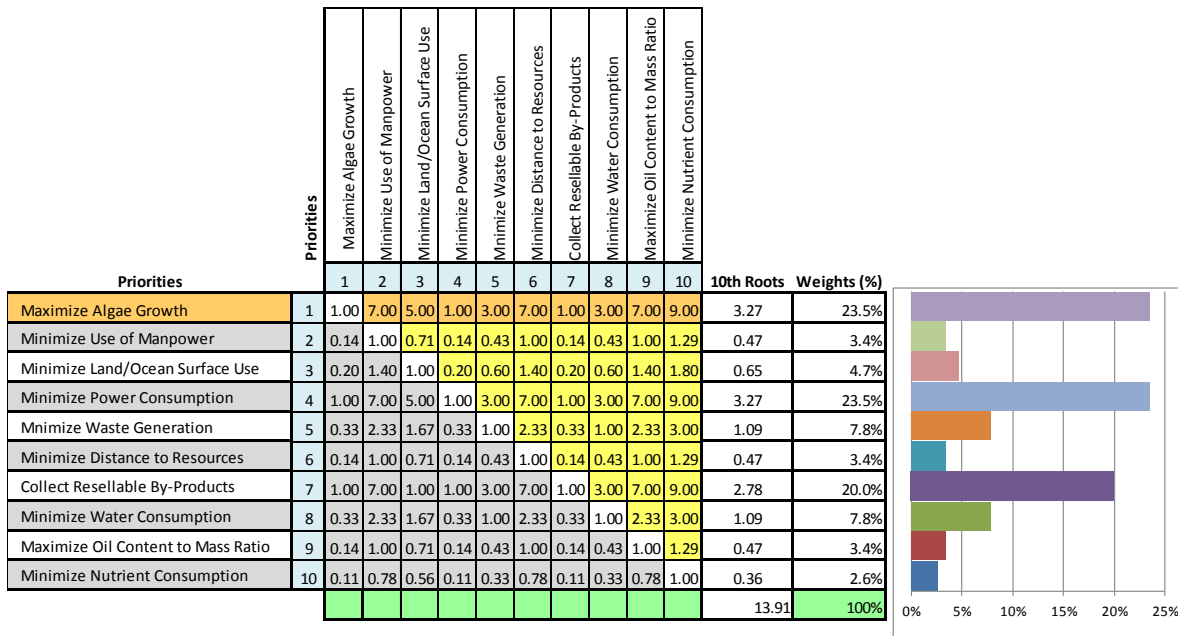

Table 5. Growth subsystem prioritization matrix showing relative priority importance after comparing the scoring in the previous section to all other priorities. This table signifies that maximizing algae growth, minimizing power consumption, and the ability to collect sellable by-products are of top importance (After Blanchard and Fabrycky 2010).

A comparative chart showing the final calculated priority weightings by percentage are shown to the right in Table 5. It is clear from the final weighting calculations that minimizing power consumption, maximizing algae output and the ability to collect resellable by-products are the top priority criteria for this subsystem. Other key priorities include minimizing water consumption and waste generation. The priority scores are based on knowing that the facility will reside within the Hawaiian Islands, which has a large bearing on how the team chose to score the priorities. These weightings will be used in the HoQ allocation matrices to determine final performance weighting for each subsystem portion of the growth system.

### (3) Requirements to Design Characteristics Allocation.

During this analysis phase, correlations were made between the customer key priorities and the design characteristics that are common to each growth method. Using the matrix show in Table 6, an interaction score of 1 (least importance), 3 (medium importance), or 9 (highest importance) was used to describe the level of interrelationship between a given

requirement and a particular characteristic. The use of scoring values of 1, 3, and 9 is a standard, nonlinear scoring method utilized for both HoQ and QFD to help pull important interrelationships to the forefront (Bahill and Chapman 1993). For example, the growth capacity has a large impact on the final algae output and is therefore scored a 9. This shows that there is a strong interrelationship between maximizing the algae output and total capacity of the system. Changes in growth capacity can have large consequences in how much algae the system is able to produce over a given time period by adding additional parallel capacity. Design characteristics that do not affect a requirement are scored as zero and a blank in the matrices. The design characteristics selected were chosen to be generic enough to apply to all the various growth methods.

		Design Characteristics											
		Uptime	Manpower	Facility Footprint	Distance to Nutrient Supply	Distance to Harvesting Facility	By-product Output	Growth Rate	Growth Capacity	Growth Cycle Period	Water Usage	Nutrient Usage	Energy Usage
Customer Priorities	Weights												
Maximize Algae Growth	23.5%							9	9	9			
Minimize Use of Manpower	3.4%	3	9	1									
Minimize Land/Ocean Surface Use	4.7%			9									
Minimize Power Consumption	23.5%		1	3									9
Mnimize Waste Generation	7.8%						3						
Minimize Distance to Resources	3.4%				9	9							
Collect Resellable By-Products	20.0%						9						
Minimize Water Consumption	7.8%			1					3		9		
Maximize Oil Content to Mass Ratio	3.4%	1							9	9			
Minimize Nutrient Consumption	2.6%				1				3			9	
	Weighted Performance	0.13	0.54	1.24	0.33	0.30	2.03	2.11	2.73	2.42	0.70	0.23	2.11
	Percent Weight	0.9%	3.6%	8.3%	2.2%	2.0%	13.7%	14.2%	18.3%	16.2%	4.7%	1.6%	14.2%

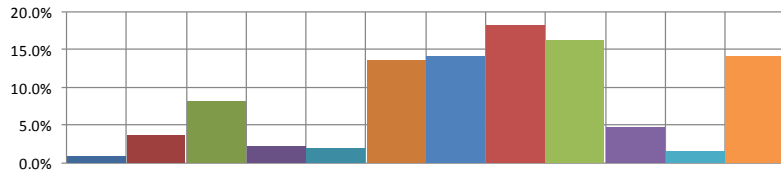

Table 6. Growth subsystem priorities to design characteristics matrix showing strong weighting requiring large growth capacity (18.3%) with by-product output, growth rate, and growth cycle period as other key characteristics.

The final design characteristic scores were normalized and weighted to calculate a percentage. The importance of each characteristic is shown as a percentage of the total score. For example, the top characteristic, growth capacity, is weighted at 18.2%. The results of this analysis showed that growth capacity, growth rate, growth cycle period, and by-product output are the most important characteristics. This is not to say that the other characteristics are not considered but that the top characteristics take priority. This means that the optimal growth method would primarily focus on providing enough capacity to produce the required quantities of algae, at the required rate. The growth facility method will also require a means to extract by-product to sell, as that is a key characteristic. Methods that are not suitable for the quantities required for the HNAABS configuration that are unable to meet these design characteristics will probably

not be selected. These final weightings from mapping of priorities to design characteristics interrelationships are then utilized to score the interrelationships between the design characteristics and the functions the growth system will have to perform. This scoring is described in the next section.

In addition to growth rate, capacity, and cycle, by-product output, facility footprint, and energy usage were scored fairly high. The scores indicated that these characteristics will need to be taken into account in the final selection due to their perceived impacts to the algae output.

(4) **Design Characteristics to Functions Allocation.** Table 7 shows the matrix of interactions between the system design characteristics and the functions the system must perform. The weights in the second column are the results of the values calculated during the priorities to design characteristics interrelationship mapping from the previous section. As in the previous section, score values of 1, 3, or 9 were used to define the strength of interrelationship between individual design characteristics and system functions with functions that did not relate to characteristics receiving a score of zero (shown as blank). The functions selected in Table 7 are the functions that the growth subsystem will perform and are consistent with the CORE<sup>®</sup> systems engineering model. The products of the scoring values in this analysis and the weights obtained from the previous analysis were then used to rank the relative importance of each function to the growth method to be chosen.

As an example: A Manpower score of 3 in Clean System is multiplied by the weight of Manpower in the overall order of Design Characteristics to contribute 0.108 normalized scoring points to the importance of the Clean System function, when compared to the other system functions. When this process is repeated for all characteristics that affect the Clean System function, the resulting sum was found to be 0.87 normalized scoring points, which was 6.1% of the total available points. This weighting is then transferred forward according to the process as described previously in Section III.A.1

Design Characteristics	Weights	Functions								
		Innoculate Algal Biostock	Regulate Nutrients	Agitate Growth Medium	Control Growth Environment	Monitor Growth Environment	Regulate Water	Clean System	Output Mature Algae	Maintain Growth System
Uptime	0.9%							9		9
Manpower	3.6%	3	3	3	3	3	3	3		3
Facility Footprint	8.3%		1	1	1	1	1	1		1
Distance to Nutrient Supply	2.2%	3	9							
Distance to Harvesting Facility	2.0%								9	
By-product Output	13.7%							3		
Growth Rate	14.2%	3	3	3	9	3	1			
Growth Capacity	18.3%	3	3	3	3	3	1			
Growth Cycle Period	16.2%	3	1	3	3	3	1		3	
Water Usage	4.7%			1	1		9	1		
Nutrient Usage	1.6%		9		1					
Energy Usage	14.2%	1	3	3	3	1	3	1		1
Weighted Performance		1.78	2.10	2.13	3.00	1.80	1.53	0.87	0.67	0.41
Percent Weight		12.5%	14.7%	14.9%	21.0%	12.6%	10.7%	6.1%	4.7%	2.9%

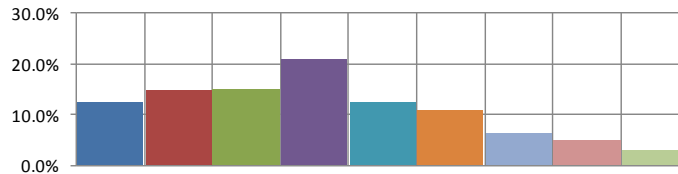

Table 7. Growth subsystem design characteristics to functions matrix. By using the weightings calculated in the previous sections (2<sup>nd</sup> column) and the interrelationship scoring the final function weightings show that controlling growth environment being the top ranked function with agitate algae and regulate nutrients the next highest ranked functions.

The results in Table 7 show that the Control Growth Environment function has the highest rank, which is intuitive since this is the key function performed by the growth system to make sure that the algae is grown at a proper rate and quantity. Other important functions, based on their calculated weights, include Agitate Growth Medium, Regulate Nutrients, and Monitor Growth Environment. These functions directly

impact the algae output from the growth system and therefore are needed in the growth method that will be chosen.

(5) **Functions to Subsystem Allocation.** The functions identified in the previous matrix were then allocated to the actual physical components that will make up the growth system to be selected. To accomplish this, score values of 1, 3 or 9 were assigned to physical assemblies or subsystems based on their interrelationship with a particular system function. The components selected during this analysis were generic and applicable to all the growth method alternatives. The components also line up with the components as defined in the CORE<sup>®</sup> systems engineering model. The results of this analysis are shown in Table 8.

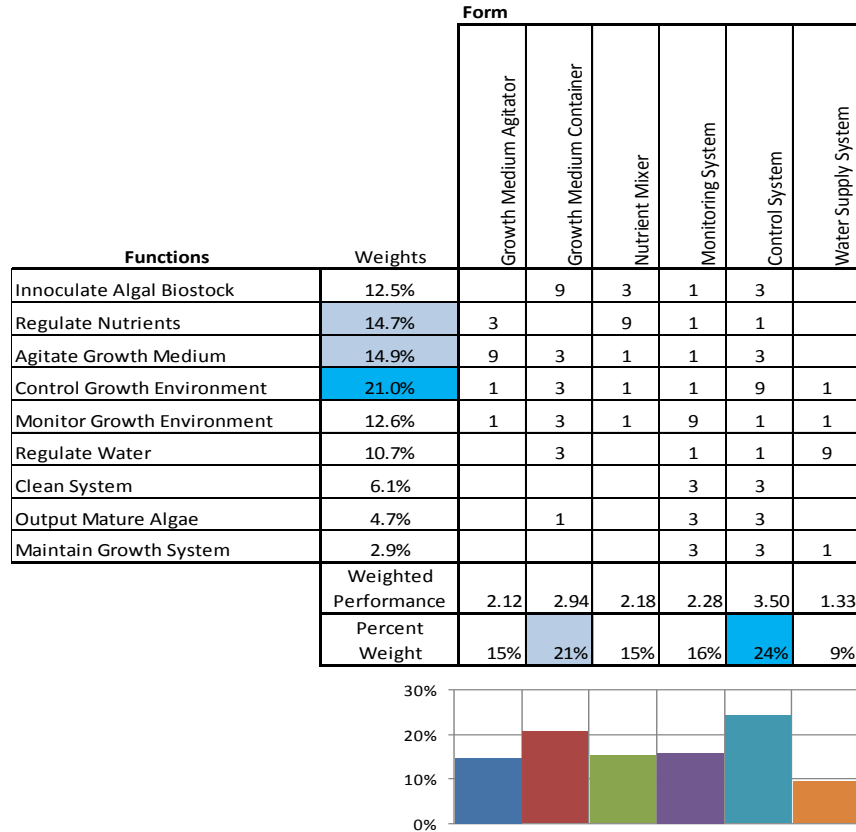

Table 8. Growth subsystem functions to physical components matrix showing control system with the highest ranking (24%) and growth medium container the next highest (21%).

The relative weights of each component, obtained by adding the products of the function weights calculated in the previous section and the interrelationship scores, showed that the growth medium and the control system are deemed to be the most important components of the growth system. Other components, although ranked lower, are still important to the functions of the growth system.

(6) **Final Performance Weighting.** Once the final performance weighting is calculated, a mapping is required to correlate the generic performance weighting for the growth system to each alternative that was investigated. In this case, each alternative was studied to assess the performance in each physical subsystem. For example, the nutrient feed system for a pond is not nearly as efficient as the correlating feed system for a photobioreactor. The scores used within this performance scoring were taken from data within the previous sections describing the

various growth subsystems in detail. This performance comparison matrix is meant to show comparative performance that incorporates the results of various research projects for the different alternatives described in the previous section. For scoring, a value of 1, 2, or 3 with 3 representing the systems with the largest quantity of the aspect in question was utilized for this scoring. For performance scoring, a 3 indicates the system has the best performance and would therefore be considered the best in that category. In future comparisons, a score of 3 would indicate the system has the most cost or environmental risk which would indicate the system is the worst performing system. To assist the reader, good scores are colored green, and poor scores are colored red in all performance/cost/environmental comparison tables.

The results of the scoring matrix can be seen in Table 9. This matrix can be used by subject matter experts for a particular system and may utilize raw performance values for more accurate performance estimates. These scores are meant to be generic yet representative of each method to show how the process can be used. What can be shown on this matrix is that the performance of the growth medium and control system are weighted heavily. That means that even if a system alternative performs very poorly for the lower weighted items and excels at the higher priority components, that alternative has a much higher chance of outperforming the other options.

	Growth Medium Agitator	Growth Medium Container	Nutrient Mixer	Monitoring System	Control System	Water Supply System	
<b>Performance Weighting</b>	14.7%	20.5%	15.2%	15.9%	24.4%	9.3%	
<b>Pond</b>	3.00	2.00	1.00	1.00	2.00	1.00	
<b>Hybrid</b>	2.00	3.00	2.00	3.00	3.00	1.00	
<b>Photobioreactor</b>	2.00	2.00	3.00	3.00	3.00	2.00	
<b>Heterotrophic Bioreactor</b>	2.00	2.00	2.00	3.00	3.00	2.00	
<b>OMEGA</b>	3.00	3.00	3.00	1.00	1.00	3.00	
							<b>WEIGHTED PERFORMANCE TOTAL</b>
<b>Pond</b>	0.44	0.41	0.15	0.16	0.49	0.09	1.74
<b>Hybrid</b>	0.29	0.61	0.30	0.48	0.73	0.09	2.52
<b>Photobioreactor</b>	0.29	0.41	0.46	0.48	0.73	0.19	2.55
<b>Heterotrophic Bioreactor</b>	0.29	0.41	0.30	0.48	0.73	0.19	2.40
<b>OMEGA</b>	0.44	0.61	0.46	0.16	0.24	0.28	2.19

Table 9. Growth subsystem performance rating to alternatives performance comparison matrix showing raw scores on top and normalized scores on the bottom with the final weighted performance on the right. Photobioreactor has top performance score with hybrid and heterotrophic next highest.

From incorporating priorities, traced through design characteristics to functions and then finally to physical components, the final performance scoring shows that the photobioreactor method is the top performer. The next closest are the heterotrophic bioreactor and hybrid alternatives. Performance is only one facet of the analysis of alternatives. Cost and environmental risks are analyzed in the next section. All three factors are then compared to each other independently to show what alternatives remain within the trade space.

It is important to understand that the scoring is comparing general performance of one system alternative to the others. Another problem with this analysis

of alternatives up to this point is that there is no consideration for technical maturity. This is especially important since performance weightings for systems, such as OMEGA, are estimation from early technical assessments of performance. This must be taken into account when looking at the three aspects of cost, environmental, and performance when making a final decision.

(7) **Cost and Environmental Weighting.** The other two dimensions that need to be analyzed are the comparative cost and environmental impact/risk for each alternative. For this case, multiple cost and environmental factors are taken into consideration and scored a 1, 2, or 3 for their cost or environmental impact. For environmental and cost comparisons, the lower number reflects a lower impact (better). The scoring values of 1, 2, or 3 are chosen due to the general alternatives analyzed. These scores represent the general cost or environmental risk of one generic system alternative over another. While these results are representative, a more specific cost or environmental analysis can be performed by using actual cost values. For example, there are many photobioreactor systems to work from and one may desire to know, to a high degree of accuracy, the cost risk of one PBR compared to another. In that situation, actual dollar costs may be normalized and substituted in for the 1, 2, or 3 scores utilized here.

The results of the cost scoring can be seen in Table 10 for raw values for weighted values. From a cost perspective, the pond system is on the low end of the spectrum, with hybrid on the highest end of the cost risk spectrum, since it requires multiple systems combined. The different cost parameters were analyzed, not by their actual cost, but by their relative cost impact compared to the other alternatives. The data used to determine these simplified scores is derived from the descriptions of the various alternatives in the previous section.

Wt	Parameters and Impacts	Open Pond	Photobioreactor	Heterotrophic Fermentation	OMEGA	Hybrid
30%	Complexity and Technical Risk	1	2	3	3	2
20%	Manpower and Specialization	1	2	2	3	3
25%	Capital (Power)	2	2	2	3	3
25%	Capital (Land)	3	2	2	1	3

Wt	Parameters and Impacts	Open Pond	Photobioreactor	Heterotrophic	OMEGA	Hybrid
30%	Complexity and Technical Risk	0.3	0.6	0.9	0.9	0.6
20%	Manpower and Specialization	0.2	0.4	0.4	0.6	0.6
25%	Capital (Power)	0.5	0.5	0.5	0.75	0.75
25%	Capital (Land)	0.75	0.5	0.5	0.25	0.75
	Total weight	1.75	2	2.3	2.5	2.7

Table 10. Growth subsystem cost comparison analysis matrix with raw scores on the top and weighted scores on the bottom. The lower the score the lower the cost risk (better) and this shows that the pond system has the lowest cost risk with photobioreactor the next lower.

Similar to the cost risk scoring, the environmental comparison went under a comparative analysis. The scoring method is the same as the cost risk scoring, with the lower score being the better option. Based on the relative rankings, the pond is the highest risk from an environmental perspective, with OMEGA (estimated), being on the lowest. Table 11 shows the final results of the comparative environmental analysis. The top portion shows the raw scores with the bottom portion showing the weighted scores. The environmental risk comparative scores are derived from data in the previous section describing the details of the different growth alternatives. A key feature of the score results is that the pond system shows the greatest environmental risk since the pond system is open to the environment and all others are closed. The only exception is the hybrid system, where a portion of the system is still open to the environment. OMEGA also has a high estimated risk for the ecosystem since pipes from waste management systems need to be run under the surface of the ocean and may be susceptible to failure with large consequences. However, OMEGA uses very little land and no freshwater allowing it to have, by far, the best score.

Wt	Parameters and Impacts	Open Pond	Photobioreactor	Heterotrophic Fermentation	OMEGA	Hybrid
40%	Land Usage	3	2	2	1	2
15%	Water Consumption	3	2	1	1	3
15%	Water Waste	3	2	2	1	3
15%	Energy	2	2	2	1	3
10%	Ecosystem	3	1	2	3	3
5%	Air	2	1	1	1	2

Wt	Parameters and Impacts	Open Pond	Photobioreactor	Heterotrophic Fermentation	OMEGA	Hybrid
40%	Land Usage	1.2	0.8	0.8	0.4	0.8
15%	Water Consumption	0.45	0.3	0.15	0.15	0.45
15%	Water Waste	0.45	0.3	0.3	0.15	0.45
15%	Energy	0.3	0.3	0.3	0.15	0.45
10%	Ecosystem	0.3	0.1	0.2	0.3	0.3
5%	Air	0.1	0.05	0.05	0.05	0.1
	<b>Total weight</b>	2.8	1.85	1.8	1.2	2.55

Table 11. Growth subsystem environmental comparison analysis matrix with raw scores on the top and weighted scores on the bottom. The lower the score the lower the environmental risk (better) and shows that the OMEGA system has the lowest environmental risk and the pond system being the highest environmental risk.

The two bioreactors (PBR and heterotrophic) have the next lowest amount of risk to the environment. The bioreactors have a low score because they are closed systems that do not require as much land as a hybrid or pond system. All system alternatives have the ability to be co-located with a current industrial facility that outputs large amount of wastes that could be converted to nutrients. Such facilities could include waste management facilities, power plants, or areas of agricultural waste. The proximity to these sources could help offset some major environmental concerns.

(8) **Results.** With all cost, performance, and environmental comparative weights complete, a careful analysis of final selection was performed. To do

this, a three dimensional comparison of the three parameters was observed for the best trade-off selection, given priorities and derived system performance, cost, and environmental factors. Table 12 shows a side-by-side view of the calculated results for each dimension. The higher the performance scores, the better the alternative. For cost and environmental, the lower values are the better selections (least impact/risk).

	Results		
	Cost (Lower Better)	Performance (Higher Better)	Environmental (Lower Better)
<b>Pond</b>	1.75	1.74	2.80
<b>Hybrid</b>	2.70	2.52	2.55
<b>Photobioreactor</b>	2.00	2.55	1.85
<b>Heterotrophic Bioreactor</b>	2.30	2.40	1.80
<b>OMEGA</b>	2.50	2.19	1.20
<b>Max Possible Score</b>	3.0	3.0	3.0

Table 12. Growth subsystem raw results of cost, environmental and performance weights. For cost and environmental, the lower score the better. For performance, the higher score the better. Signifies that pond has lowest cost risk, PBR has highest performance, and OMEGA has lowest environmental risk.

The raw scores were then normalized by the best possible score values. That is, normalized to the score compared to an alternative that would score the highest marks in all factors. This allows for an easier way to view the trade-off analysis from a 0 to 1 score for all comparison factors. Table 13 shows the result of normalizing the results to the maximum possible score.

Results (Normalized)			
	Cost (Lower Better)	Performance (Higher Better)	Environmental (Lower Better)
<b>Pond</b>	0.583	0.58	0.93
<b>Hybrid</b>	0.900	0.84	0.85
<b>Photobioreactor</b>	0.667	0.85	0.62
<b>Heterotrophic Bioreactor</b>	0.767	0.80	0.60
<b>OMEGA</b>	0.833	0.73	0.40
<b>Max Possible Score</b>	1.0	1.0	1.0

Table 13. Growth subsystem normalized results of cost, environmental and performance weights to the best possible score. For cost and environmental, the lower score the better. For performance, the higher score the better. Signifies that pond has lowest cost risk, PBR has highest performance, and OMEGA has lowest environmental risk.

The final scores for each factor of cost, performance, and environmental were compared to each other in each dimension. For example, when looking at cost and performance, the best possible score would be a 1.0 for performance and a 0.0 for cost. The distance of the cost and performance score was calculated to that best possible score. Table 14 shows the results of calculating the distance of each comparison to the best possible scores. This distance calculation objectively showed which system alternative was the best system alternative for each comparison. For cost and environmental, the lower values indicated lower impact/risk and more desirable. For performance, the higher the value the better performance result with the highest number being the best performing system. For the overall distance calculations for all comparisons, the lower the number is better. Another way to describe the score is that, for the cost versus performance, the alternative with the lowest score provides the best performance per dollar spent.

<b>Lower Score is Better</b>	Environmental vs. Performance	Cost vs. Performance	Cost vs. Environmental
<b>Pond</b>	1.02	0.72	1.10
<b>Hybrid</b>	0.87	0.91	1.24
<b>Photobioreactor</b>	0.63	0.68	0.91
<b>Heterotrophic Bioreactor</b>	0.63	0.79	0.97
<b>OMEGA</b>	0.48	0.88	0.92

Table 14. Growth subsystem top scoring alternatives in factor comparison. Showing how close a given alternative is to the best possible scores with the lower number being better. For both cost vs. performance and cost vs. environmental the photobioreactor has the best score with OMEGA showing the best environmental vs. performance score.

These final scores are all compared to each other graphically to visually observe the mapping and trade-space for each alternative. Figure 41 shows the cost to performance comparison. In this chart, the systems to the top-left have the lowest distance to the best possible score (lowest cost risk and highest performance estimate). In this case, the pond and photobioreactor system are the only alternative selections along the efficient frontier. This means that there is trade-space between the pond and photobioreactor alternatives. If higher cost risk is acceptable there is higher performance to be gained from using the photobioreactor method. If higher cost risk is unacceptable then the pond alternative can be selected with reduced performance compared to PBR. The other alternatives are not within the efficient frontier as they provide lower performance for higher cost risk than another alternative. Dependent on priorities, the pond may be more attractive due to lower cost with loss in performance. However, the photobioreactor is numerically the best choice in this comparison with the small distance to the best possible score (in this case the top-left of the chart). For cost to performance between the pond and photobioreactor, there is almost a proportional relationship between the increases of performance to the increase in cost impact of the possible two alternatives.

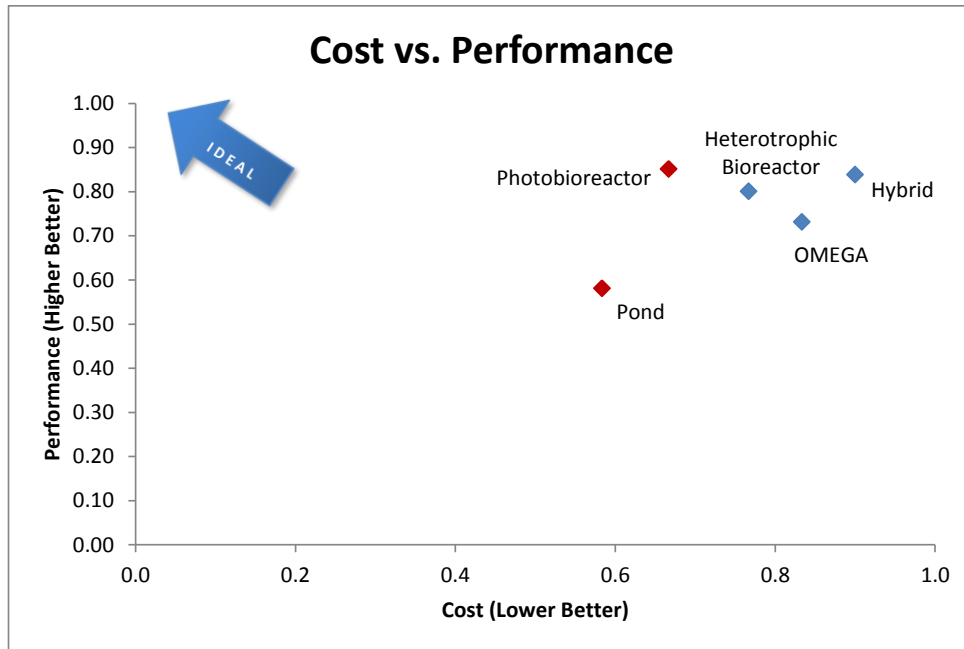

Figure 41. Growth subsystem cost vs. performance chart showing that pond and photobioreactor alternatives within the efficient frontier (shown in red). Photobioreactor has higher performance with higher cost risk and pond has lower performance with lower performance. The other alternatives are not within the efficient frontier.

Figure 42 shows the environmental to performance chart for each cultivation alternative. In this situation again, the top-left alternatives are closest to the best possible score (highest performance and lowest environmental impact/risk). The OMEGA system, by distance to the best score possible, is much closer to the best possible score than all other alternatives with a very low estimated environmental risk, but lower performance estimate. The heterotrophic bioreactor and the photobioreactor are still within the efficient frontier. Both bioreactor systems also have higher performance estimates with higher environmental risks. Having the cultivation system in Hawaii may highlight the necessity for strong environmental controls as well as land usage issues. Depending on the environmental priorities, OMEGA may be a viable alternative for incorporation into the Hawaiian environment. Provided that the technical maturity increases for OMEGA, it could become a more attractive candidate. The photobioreactor, however, is a proven system that is already in place and operating within the Hawaiian environment. There are environmental concerns due to the larger land footprint and

infrastructure required to produce algae on an industrial scale, but the photobioreactor receives high performance marks due to actual large scale growth results within the intended environment.

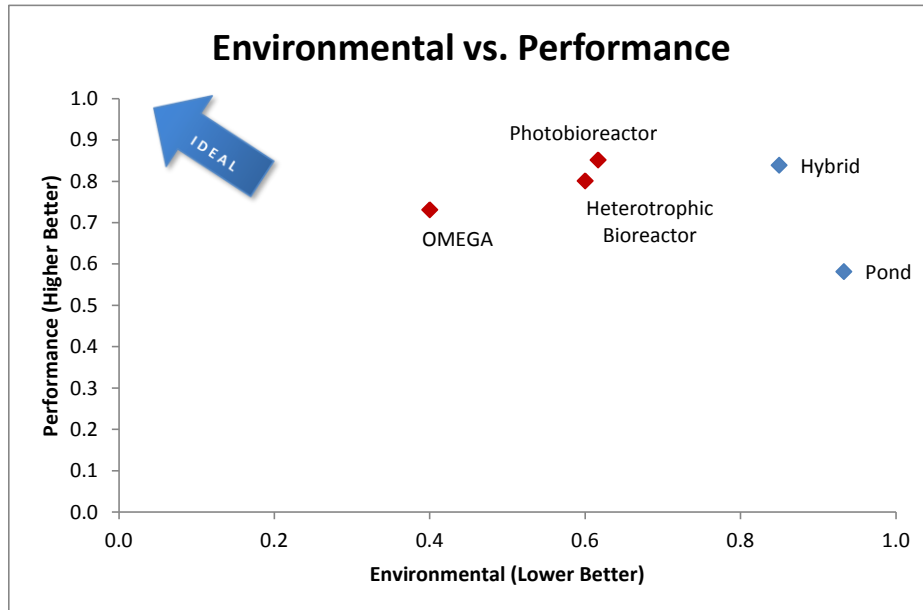

Figure 42. Growth subsystem environmental vs. performance chart showing that pond, photobioreactor, and OMEGA alternatives within the efficient frontier (shown in red). Photobioreactor has higher performance with higher environmental risk and OMEGA has lower performance with lower environmental risk.

For the final dimension of comparison, we look at the interaction of cost and environmental impact/risk. In this comparison the system in the bottom-left is the ideal choice (lowest cost impact and lowest environmental impact). Figure 43 shows the results of the cost and environmental comparison. The chart shows that every alternative is within the efficient frontier except for the hybrid system. This means there is wide trade-space between the four remaining alternatives depending on how the stakeholder values cost or environmental priorities. As discussed in the previous environmental comparison chart, OMEGA scores very low in the environmental risk area because of the reduced land impact and infrastructure requirements. It, however, has a very high cost risk and impact due to the very low technical maturity with unknown and unproven cost estimates. Pond, still in the trade-space, has very low cost but also has a

high environmental risk impact. The high environmental risk stems from the fact that the system is open to the environment and utilizes a very large land footprint. The best alternative with the closest distance to the best possible score is the photobioreactor system. The photobioreactor alternative both provides not only balance of environmental and cost risk, but photobioreactor systems have already been integrated within the Hawaiian environment.

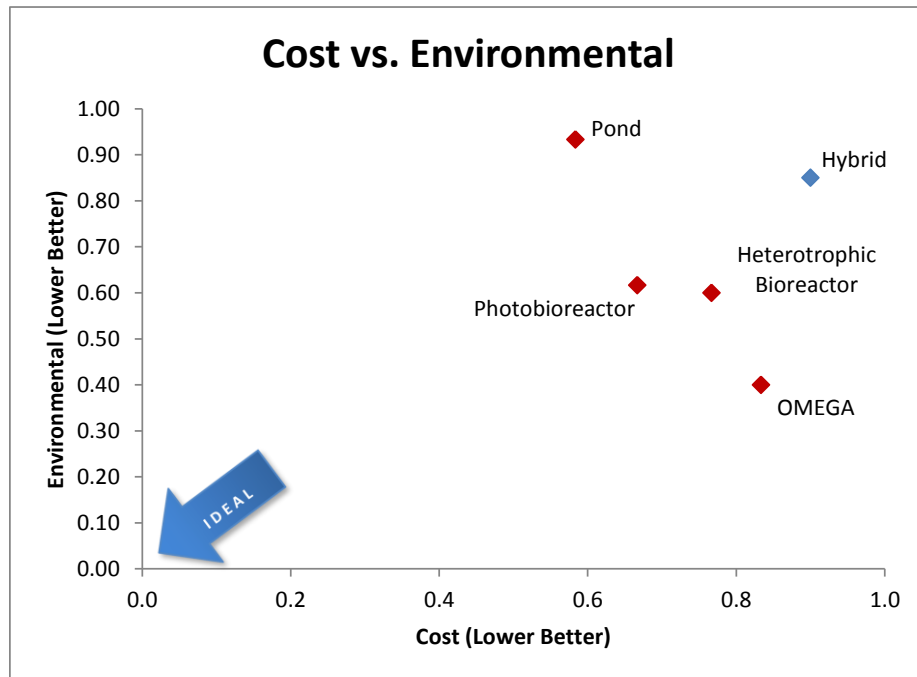

Figure 43. Growth subsystem cost vs. environmental chart showing that all alternatives except hybrid are within the efficient frontier (shown in red). Photobioreactor is closest to the best possible score (bottom-left).

*e. Recommendations*

When all three dimensions are reviewed, the objective selection is the photobioreactor. From performance, technical maturity, cost, and environmental viewpoints, the photobioreactor is the recommended system to be analyzed within the final cultivation configuration. In the case of cost and environmental together, the photobioreactor is scored as the best selection. Since the HNAABS cultivation is designed to be located on the islands of Hawaii, where environmental impacts are of high concern, environmental weights may be given greater consideration over costs. In that

situation, OMEGA could be selected due to the limited land requirements and impact. If costs were of critical concern over environmental or performance then the pond system could be selected, due to the lower cost associated with it. The team selected photobioreactor for the balance of cost and environmental while still provided high performance over the other methods.

While the recommended alternative selected was the photobioreactor, both OMEGA and the heterotrophic bioreactors are very promising candidates. The reason the performance scores are lower than the other alternatives is heavily due to the lower technical maturity that drives the higher cost risk and the lower performance estimates. The goal of the final configuration is to build a large industrial scale commercial cultivation system and no single alternative currently exists that grows algae on such a large scale within Hawaii. Pond, photobioreactor, and the hybrid pond/photobioreactor are the only alternatives with commercially fielded systems, with OMEGA and heterotrophic bioreactors in very early development. Both OMEGA and the heterotrophic bioreactors show promising signs of performance and feasibility. However, it may be years for the technical maturity to be at the level that is viable for large scale production system. Given the available land and infrastructure, it is of little doubt that an industrial sized algae growth facility can use photobioreactors or the pond system as they have been proven for technical viability at such a scale.

From the cost analysis that was performed, it was calculated that HNAABS photobioreactor algae form would contribute \$4.63 per gallon of the bio-kerosene produced. This lines up with rough estimates from economic analysis of growing algae for bio-fuel (Allison, Outlaw and Richardson 2010). The cost estimates calculated were based on the Simgae™ photobioreactor system from Diversified Energy and were detailed in the cost analysis section of this report. There are many forms of photobioreactors in existence and the final cost estimates could have large variations depending on the photobioreactor system selected.

A sensitivity analysis was performed to determine the effect the original requirements priorities had on the final selection of the system. Table 15 shows the priorities that were shifted to perform the sensitivity analysis. The red highlighted

sections are the original priority scores used for the analysis of alternatives. The blue and purple highlighted scores were used for the sensitivity analysis to show how different priorities could affect the final performance score. These new priority scores reflect a scoring that desires minimizing manpower and minimizing distance to resources (purple) and minimizing power, water, and land consumption (blue).

Item	Rate (COMBINED)									Item
Maximize Algae Growth	9	7	5	3	1	3	5	7	9	Minimize Use of Manpower
Maximize Algae Growth	9	7	5	3	1	3	5	7	9	Minimize Land/Ocean Surface Use
Maximize Algae Growth	9	7	5	3	1	3	5	7	9	Minimize Power Consumption
Maximize Algae Growth	9	7	5	3	1	3	5	7	9	Mnimize Waste Generation
Maximize Algae Growth	9	7	5	3	1	3	5	7	9	Minimize Distance to Resources
Maximize Algae Growth	9	7	5	3	1	3	5	7	9	Collect Resellable By-Products
Maximize Algae Growth	9	7	5	3	1	3	5	7	9	Minimize Water Consumption
Maximize Algae Growth	9	7	5	3	1	3	5	7	9	Maximize Oil Content to Mass Ratio
Maximize Algae Growth	9	7	5	3	1	3	5	7	9	Minimize Nutrient Consumption

Table 15. Modified requirements priority scoring for sensitivity analysis. These modified scores (blue and purple) were used in the analysis of alternatives process to determine how much the priorities scoring adjustments changed the final performance results.

It was determined that the priority scores had negligible effect on the final performance scoring. Table 0 shows the final performance scores that result from the change in the initial priority scores. When compared to the results in Table 14, the results are of negligible difference and do not affect the final rankings.

	Environmental vs. Performance	Cost vs. Performance	Cost vs. Environmental
Lower Score is Better			
Pond	1.0359	0.7364	1.1006
Hybrid	0.8666	0.9157	1.2379
Photobioreactor	0.6304	0.6794	0.9081
Heterotrophic Bioreactor	0.6310	0.7911	0.9735
OMEGA	0.4861	0.8779	0.9244

	Environmental vs. Performance	Cost vs. Performance	Cost vs. Environmental
Lower Score is Better			
Pond	1.0271	0.7239	1.1006
Hybrid	0.8702	0.9191	1.2379
Photobioreactor	0.6383	0.6867	0.9081
Heterotrophic Bioreactor	0.6353	0.7946	0.9735
OMEGA	0.4711	0.8697	0.9244

Table 16. Sensitivity analysis final performance results showing no difference from original analysis of alternatives results. The best systems for each comparison are highlighted.

In addition to the prioritized requirement analysis, sensitivity analysis was also performed to determine the effects of weighting the environmental, cost, and performance scores on the overall system design. While previous analysis scored the three dimensions equally, the sensitivity analysis investigated cases in which the scores were highly biased toward one particular attribute. For example, when cost was rated as 80% of the overall score, the relatively inexpensive pond system became the best growth alternative as shown in Table 17.

	0.8	0.1	0.1	
	Cost	Env	Perf	3D distance
<b>Pond</b>	0.58	0.93	0.58	0.61
<b>Hybrid</b>	0.90	0.85	0.84	0.85
<b>PBR</b>	0.67	0.62	0.85	0.63
<b>Hetero</b>	0.77	0.60	0.80	0.71
<b>OMEGA</b>	0.83	0.40	0.73	0.76

Table 17. Sensitivity analysis showing variation when cost represents 80% of the importance of the overall system. The 3D distance refers to the distance from the ideal point in 3-dimensional space. This ideal solution would score 0, 0, and 1 for cost, environmental impact, and performance respectively.

Alternatively, as environmental risks took precedence in the system rankings, the OMEGA alternative came to be the best candidate for the HNAABS design. Table 18 shows the resulting three-dimensional distance to the ideal solution when environmental impacts account for 50% of the system priorities.

	0.25	0.5	0.25	
	Cost	Env	Perf	3D distance
<b>Pond</b>	0.58	0.93	0.58	0.75
<b>Hybrid</b>	0.90	0.85	0.84	0.76
<b>PBR</b>	0.67	0.62	0.85	0.56
<b>Hetero</b>	0.77	0.60	0.80	0.58
<b>OMEGA</b>	0.83	0.40	0.73	0.52

Table 18. Sensitivity analysis showing variation when environmental impacts represent 50% of the importance of the overall system.

Finally, because the PBR system exhibited the best performance of the five alternatives, it remained the best overall candidate as performance was given higher priority in the system design. This sensitivity analysis shows that the analysis process is highly dependent upon stakeholder inputs and design prioritization. Overall, however, the PBR system represents the best alternative across the range of possible scenarios, lending further support to the HNAABS Team's decision to incorporate a PBR growth system in the final system design.

### **3. Harvest Subsystem Analysis of Alternatives**

An analysis process comparable to the approach used by the Growth team was utilized to evaluate the harvesting subsystem alternatives. Results show that the microfiltration process represents the best HNAABS design solution at an operating cost of about \$16.9 million per year. This contributes about \$0.53 to the price of each gallon required to meet the USPACOM biofuel production goals. Further analysis found a way to avoid this cost based on top-level system interactions; however, this estimate is still useful in benchmarking the approximate impact of this technology. The following sections will describe the process by which the algal biomass is recovered from the growth stage, discuss the pros and cons of five harvesting alternatives, explain the methodology used by the HNAABS Team to assess the alternatives, and ultimately present the Harvest Team recommendation for incorporation into the HNAABS design.

#### ***a. Scope and Background***

Following the algae growth process, harvesting the algal biomass is the second phase of the four-phase cultivation AoA. Harvesting is the process by which the biomass is recovered from the aqueous growth medium. For the purposes of this project effort, the harvest process was considered to be an intermediate step in which a portion of the water was removed from the algal solution. In most cases a subsequent drying process must be performed before extraction of the green crude oil can take place. The end result of the harvest process is algal slurry or algal cake with a percentage of total suspended solids (% TSS) between 2-25% TSS as depicted in Figure 44.

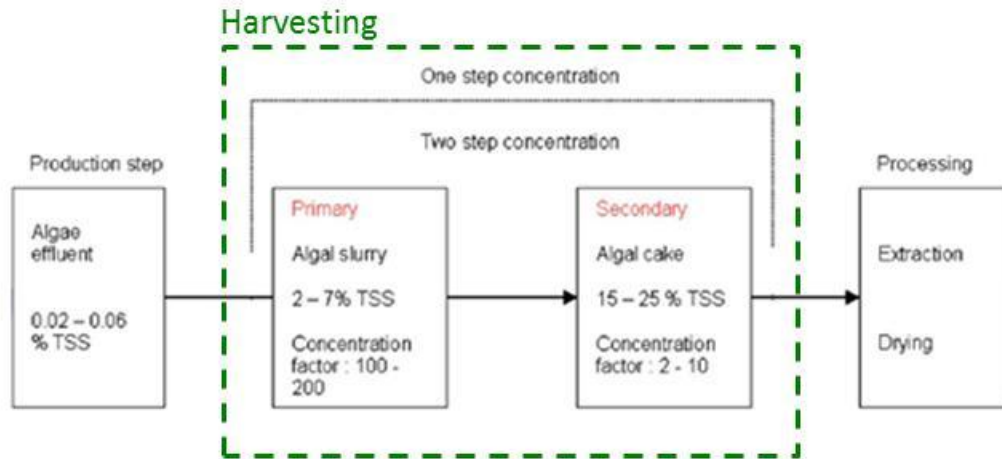

Figure 44. Harvesting as a part of the overall cultivation process (After Green, Shelef, & Sukenik, 1984).

The harvest process is highly dependent upon the end product specifications required prior to passing the algal slurry to the drying facility. Based on the external system boundaries devised by the Team, this threshold was met when the algal slurry reaches a composition of at least 20% TSS. While the Harvest Team analysis investigated each harvest process as a separate entity in order to develop the requisite cost, performance, and environmental data, it should be noted that in many cases, combinations of these processes are required to meet the harvest process goal of 20% TSS. Once each cultivation step was thoroughly analyzed from an individual process standpoint, a final analysis was performed which accounted for external system boundaries and end process requirements to develop an optimal cultivation system solution from algae growth to green crude oil extraction.

The goal of biomass recovery is to destabilize the algae suspension in the cultivation medium such that algae aggregation can occur. The stable suspension is a function of cell dimensions, cell density in comparison to that of the growth medium, and electric charge and interactions between algae particles (Spendier 2011). Destabilization of the algal biomass is typically accomplished through one of two methods. The first involves algal particles constrained by a permeable membrane through which the liquid passes, and the second uses either sedimentation or flotation methods allowing the

particles to. Sedimentation is the process by which algal cells settle to the bottom of a container, and the rate at which sedimentation occurs can be improved by increasing cell dimensions or by amplifying the effects of gravitational force (Spendier 2011). Flotation, on the other hand, does not require increased cell sizes. This method uses aeration to form bubbles which attract algal cells to the surface of the growth medium where they are subsequently skimmed and collected. The decision to use sedimentation or flotation methods depends on the difference between the algae cell density and that of the growth medium. Algae strains with high oil contents and low densities, for example, are particularly well suited for flotation harvesting technologies (Green, Shelef and Sukenik 1984).

Algal biomass production suffers from a lack of well-defined and demonstrated industrial scale methods for harvesting, extraction, and separation of oils and lipids (Green, Shelef and Sukenik 1984). In fact, it is estimated that 20-30% of the overall costs of algae cultivation can be attributed to harvesting algal biomass from the growth medium (Grima, et al. 2003). The associated harvesting costs include the cost of harvesting infrastructure and equipment, the cost of equipment maintenance, and the cost of chemicals, manpower, and electricity. As such, choosing an efficient, cost-effective harvest process is essential to providing a feasible cultivation solution.

#### ***b. Alternatives Investigated***

As is the case with the other cultivation phases, the decision to use a particular harvesting process is dependent on a variety of factors. The choice of harvest technology is dependent on the algae species being grown, the growth medium, the algae growth process, end product requirements, and cost requirements. In other words, there is no method that represents the best harvesting option in every case (Green, Shelef and Sukenik 1984).

The algae strain chosen for cultivation is a key factor of consideration as it can drive the harvest processes being used and the amount of time required to harvest the wet biomass. Algal cell sizes that are too small, for example, can prohibit the use of low cost filtration methods unless preliminary processes are used to aggregate the cells into

larger clumps that can be easily filtered. In some cases, multiple harvest processes are required to meet the 20% TSS criteria adding to the cost and complexity of the cultivation system (Ryan 2009).

In an integrated cultivation system, the harvesting process serves multiple purposes. Not only does harvesting increase the concentration of algal biomass for further processing steps, the separation of algal biomass from the aqueous solution helps recondition the water such that it can be recycled and fed back into the cultivation process. This separation also produces protein and carbohydrate by-products that can be used as animal feed (Green, Shelef and Sukenik 1984). Centrifugation methods are beneficial in this respect as the machinery can be easily cleaned and sterilized to produce high quality products for human and animal consumption. Chemical flocculation, on the other hand, adds harmful chemicals to the algae, rendering the by-products unusable and creating additional water treatment requirements before the waste water can be cycled back into the system or released into the environment.

The following section will provide background information on the five alternative harvesting methods investigated by the HNAABS Team as well as a brief discussion of the pros and cons associated with each.

(1) **Centrifugation.** Centrifugation is a harvesting technique which uses rotation and centrifugal force to separate the microalgae from the aqueous growth medium. A motor drives the centrifuge, applying a rotational force which distributes the algae and water within the chamber based on density. The denser solid algae particles migrate toward the outer walls of the rotating chamber while the liquid, or centrate, migrates closer to the axis of rotation (Margaritis 2007).

There are two major categories of centrifuges used in algae harvesting. These include sedimentation centrifuges, called solid or imperforate bowls, and filtration centrifuges, called perforated bowls. The diagram in Figure 45 shows one type of sedimentation centrifuge used in algae harvesting.

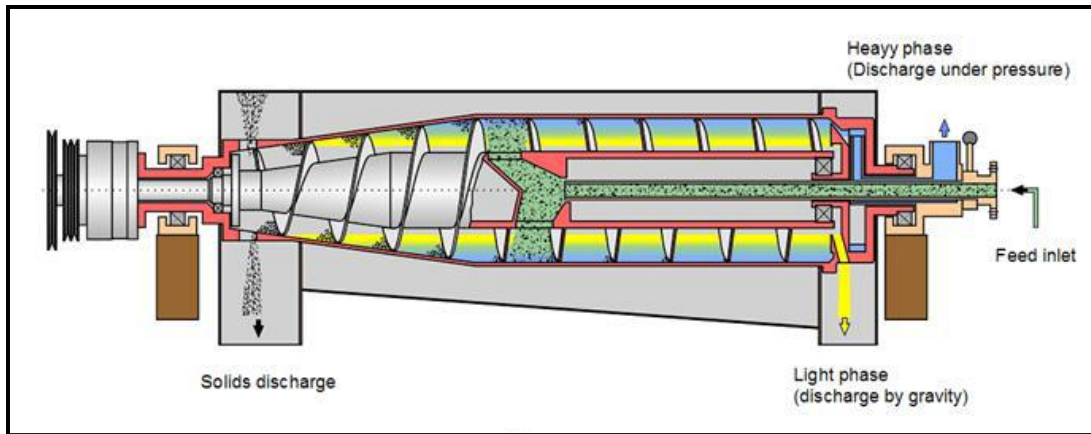

Figure 45. Perforate decanter centrifuge showing the general process by which the growth output enters the centrifuge and the biomass is discharged (From Margaritis, 2007).

The main difference between the two types of centrifuge equipment lies in the composition of the chamber walls. In a perforated bowl centrifuge, the outer wall consists of a permeable membrane. As the chamber rotates, the solid algae particles migrate radially toward the outer wall of the chamber. In this case, however, the liquid is free to pass through the sedimented solid and the chamber wall rather than migrating toward the center of the chamber (Margaritis 2007).

Centrifugation is typically a high energy process, considered by some to be impractical for large scale harvesting. Industrial centrifuges, however, are commonly used in wastewater treatment (Ryan 2009). Centrifugation has many environmental benefits when compared to other algae harvesting alternatives. There are no chemical inputs or additives, meaning the wastewater can be easily recovered and cycled back into the cultivation process (Ryan 2009). Furthermore, in addition to a lack of chemical additives, the equipment can be easily sterilized and maintained regularly (Green, Shelef and Sukenik 1984). These factors contribute to the ability to use byproducts for animal or human consumption. Unlike other harvesting processes that use mesh filters, centrifugation does not suffer from fouling due to clogged filters, although sensitive algae cells may potentially be damaged as a result of collisions with the outer wall of the centrifuge chamber (Oilgae, Centrifugation 2012). While the process is deemed to be energy intensive, it uses significantly less energy to recover biomass that

already has low moisture content. In this manner it may be possible to take advantage of the benefits of centrifugation by utilizing this process as a secondary or tertiary harvest process (Ryan 2009)

Centrifugation assessments indicate that decanter and plate centrifuges are capable of attaining 22% TSS slurry compositions (Green, Shelef and Sukenik 1984). Furthermore, current centrifuge technology can support harvesting of up to 100 gallons per minute at a cost of approximately \$200,000 to \$350,000 per piece of machinery (Centrisys Corporation 2013).

(2) **Microfiltration.** The second candidate harvesting method investigated was microfiltration. This approach is commonly carried out using membranes of modified cellulose, with the aid of a suction pump, to remove solids from fluids. Microalgae present unique filtration challenges based on cell diameter size. The membrane and filter pore size in a microfiltration system are critically important as they are driven by the size of the algae species and algae aggregation rate. Small algae tend to pass through larger pores decreasing filter efficiency. Decreasing the filter pore size, on the other hand, can lead to increased membrane fouling and reduction of filtering rates (Ryan 2009).

Conventional filtration is unsuitable for use with microalgae due to the small size of microalgae and high rate at which the algae would obscure the filter media. For recovery of microalgae, a microfiltration system is most appropriate as typical microfiltration membrane pore sizes are compatible with microalgae cell diameters less than 10 micrometers ( $\mu\text{m}$ ). The membrane of a microfiltration system is usually made up of specially treated ceramics, Teflon, polypropylene, or other plastics used to capture microorganisms (Marsh and Giannaris 1997). A benefit of microfiltration lies in the fact that this process does not generally employ chemicals and, therefore, eliminates the need for treatment and filtering of water before it can be recycled into the cultivation system (Ryan 2009).

Drum filtration is a microfiltration method which uses a mechanical harvester. This method is applicable for use with larger microalgae species such as *Oscillatoria*, *Spirulina*, and *Scenedesmus*. This concept essentially uses a belt that

traverses the drum while water flows into the drum through perforations. Filtered liquid accumulates in the drum until it is released via a 'goose-neck' pipe which incorporates a flow measuring device. The belts are maintained in tension by means of a series of unplasticised polyvinylchloride cylindrical rollers. Additionally, backwash nozzles are aligned at the most effective angle to ensure appropriate cleaning of the belt so as to reduce the fouling rate (Goh, Sim and Becker 1988).

Algae species such as *Chlorella*, *Oocystis*, *Synechocystis*, *Ankistrodesmus*, and *Raphidium* are more difficult to retain on the belt filter due to the smaller microalgae cell sizes. Overall, drum filtration has many advantages over other methods of harvesting microalgae, but the effectiveness of this filtration technique is related to the operational pore size of the filter membrane and the size of the algal species. Only algae larger than the nominal pore size of the filter weave can be retained and collected without prior treatment and cell aggregation. Despite the limitations of drum filtration, this method is relatively cost-effective due to lower energy requirements when compared with centrifugation (Goh, Sim and Becker 1988).

Another microfiltration approach for harvesting microalgae is the submerged filtration technique, typically used for harvesting freshwater algae species such as *Chlorella vulgaris* and *Phaeodactylumtricornutum*. The submerged microfiltration method applies low pressures and extracts microalgae using high cross-flow velocity and shear rates imposed onto the membrane surface. One study indicated that a membrane with a pore size of 0.037  $\mu\text{m}$  was optimal, but membrane fouling remains the biggest obstacle to more widespread use (Bilad, et al. 2011). Membrane-based filtration requires reproducible performance in conformance with the design specifications over a long period of time with periodic membrane cleaning (Cuevas, Ruanjaikaen and Zydney 2011).

Submerged membrane power consumption results suggest that the method is economically competitive to other algal harvesting methods. Results also indicate that filtration performance is directly related to the applied fluxes across the membrane with the best performance arising from high-flux membranes adapted for filtration of a specific slurry concentration level. Aside from problems associated with

membrane fouling, issues can also arise as a result of increased concentration rates as the algal slurry is filtered. The higher concentration rates affect the amount of energy required to extract the microalgae from submerged membrane bioreactors. As a result, it is crucial in submerged filtration processes to control algae slurry concentration and feed flow rate to limit energy consumption. Otherwise, a hybrid process of microfiltration and centrifugation can be used to reduce energy consumption by taking advantage of the efficiency of centrifugation at higher concentration rates use (Bilad, et al. 2011).

Performance assessments of microfiltration equipment have shown that belt press filters and chamber filtration systems can harvest biomass with solid contents equivalent to 18%TSS and 27%TSS respectively (Green, Shelef and Sukenik 1984). Additionally, a microfiltration technology demonstration report, written by PB Water in support of the Everglades construction project, assessed microfiltration operating costs to be a combination of energy costs, labor costs, membrane replacement costs, mechanical maintenance costs, and chemical coagulant costs. According to the report, a 40 million gallon per day microfiltration system costs about \$0.27 in capital infrastructure costs per gallon per day of output and uses 0.10 kWh per cubic meter based on the size of the facility. Representative labor costs include a \$30 hourly wage and 18,720 hours per year in labor to support the facility. Furthermore, membrane replacement costs average about \$15,000 per year for each microfiltration site with mechanical maintenance procedures estimated at 1% of the total capital costs of the facility (PB Water 2001).

(3) **Flocculation.** Flocculation in the most basic terms refers to the separation of a solution. Flocculation in algae harvesting refers to the process of concentrating an algae suspension until a thick paste or “floc” is achieved (Oilgae, Flocculation 2012). Often, the most rapidly growing species of algae are very small and are the most difficult to harvest. Flocculation causes the cells to clump together into a larger and more easily filtered size. The three most popular methods include chemical flocculation, electroflocculation, and autoflocculation.

Chemical flocculation uses chemicals called flocculants to aid in the separation of algae from the medium. Chemical flocculation is one of the best

methods for harvesting with regards to energy usage as it requires up to 90% less electricity than centrifugation (Ky 2011). Alum and ferric chloride are typical chemical flocculants used in the harvesting of algae. Commercial products like “Chitosan” can also be used as flocculants, but are much more expensive. The process is very effective in creating easy to filter clumps as illustrated in Figure 46, but it also creates a unique challenge downstream in the cultivation process as the additional chemicals are difficult to remove from the algae clumps. In addition, the process creates more by-products that require treatment before being released into the environment.

The chemicals generally take between 30 and 45 minutes to promote algae cell aggregation (Virginia Community College 2013). Based on estimates gathered from industry, flocculant costs can range from about \$0.06 per ton of flocculated material to about \$12 per hour of flocculation time (Clearwater Industries, Inc. 2013). A report prepared by PB Water for the South Florida Water Management District Everglades Construction Project regarding a cost estimate for a microfiltration system quoted the cost of chemical flocculants at \$0.09 per pound of ferric chloride. The report further estimates that 190 pounds of ferric chloride are required for every million gallons of biomass (PB Water 2001). Chemical flocculation is a mature technology, but is often regarded as impractical for large commercial operations due to the added chemicals and subsequent environmental impacts.

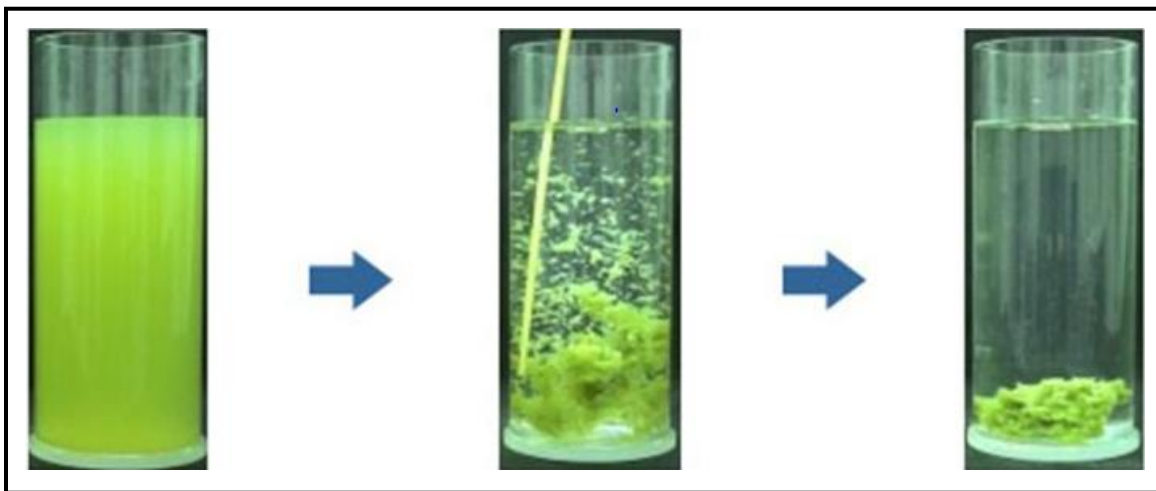

Figure 46. Visual representation of the chemical flocculation process showing the process by which algae cells aggregate and sink to the bottom of a

container (From Algae Biodiesel 2013).

Electroflocculation uses both electricity and metal ion flocculants to coagulate the algae cells (Ryan 2009). This process is most commonly used in waste water treatment. The metal ions absorb contaminants, ultrafine particles, and algae which attach to gas bubbles that are released during the process of electrolysis and float to the surface where the particles are collected and further processed (Sathe 2013). While electroflocculation is an efficient method of harvesting algae, it is also quite complicated to design an optimal system utilizing the proper current, voltage, time, salinity, pH, density, electrode material, surface area of the electrodes, and distance between electrodes. Higher salinity requires less power; however, not all microalgae can be grown at higher salinities. Although electroflocculation has roughly 95% efficiency in concentrating algae, research is still needed to optimize the process enough to be considered for commercial use (Sathe 2013). Costs associated with electroflocculation are higher than desirable for HNAABS. Electricity usage and replacement of parts such as electrodes due to usage and corrosion can be very expensive.

Autoflocculation is accomplished by changing the pH level in the algae slurry. This can be done using chemical additives such as carbonates and hydroxides (NaOH) to induce physiochemical reaction between algae. This process can promote autoflocculation as a result of carbonate precipitation in elevated pH effectively depleting photosynthetic CO<sub>2</sub> algae harvesting systems (Cranfield University 2012). Another method of autoflocculation involves interrupting the carbon dioxide supply to an algal system. This can be accomplished by removing the previously necessary agitation in the slurry that enables both the CO<sub>2</sub> and sunlight to reach the algae cells. This, in turn, causes the algae to flocculate (Osborne 2009). Autoflocculation can be a very inexpensive method for harvesting algae. However, the process may take anywhere from 24 hours to 2-3 weeks for the proper settling to occur. Autoflocculation also has shown high recovery rates, from 85-95% (Osborne 2009). While autoflocculation is a promising method for harvesting algae, it has not been proven on a large scale and is sensitive to

both algae type and slurry composition. More research is required before this method could be used for HNAABS.

Each flocculation method described in this paper has associated pros and cons. Chemical flocculation is effective at harvesting algae, but the chemicals required induce higher than desirable costs and subsequent environmental risks. The most attractive non-chemical methods of flocculation currently do not have the necessary technology readiness levels to be considered for HNAABS because they have not been proven on a large enough scale. It is suggested that future projects consider these harvesting processes once the necessary research and development has been accomplished.

(4) **Decantation.** Decantation is a basic technology which uses sedimentation to separate solids from liquids by allowing the solid precipitate to settle to the bottom of the container and by draining the top layer of liquid. Care must be taken when removing the liquid so as to prevent the solids from flowing out of the container with the excess liquids (Conjecture Corporation 2013). Figure 47 shows a set of operational sedimentation tanks currently being used by the Cellana Corporation for algae harvesting in Hawaii.



Figure 47. Photo of sedimentation tanks at Cellana facility taken by HNAABS team during fact finding trip to Hawaii.

The biomass-laden growth medium is pumped with a constant flow rate into the decanter. As the effluent continues to flow, the solids in the growth medium settle to the base of the container, and the clean liquid overflows where it is recycled or transferred to a secondary stage of treatment. For the system to be effective, the sedimentation rate must be greater than the rate at which the fluid passing through the tank rises and overflows (Dryden Aqua Technology Ltd. 2013). Sedimentation rate can also be increased through the use of flocculants. Figure 48 shows an example of how the decantation process uses sedimentation principles to separate the solids, liquids, and oils based on density differences.

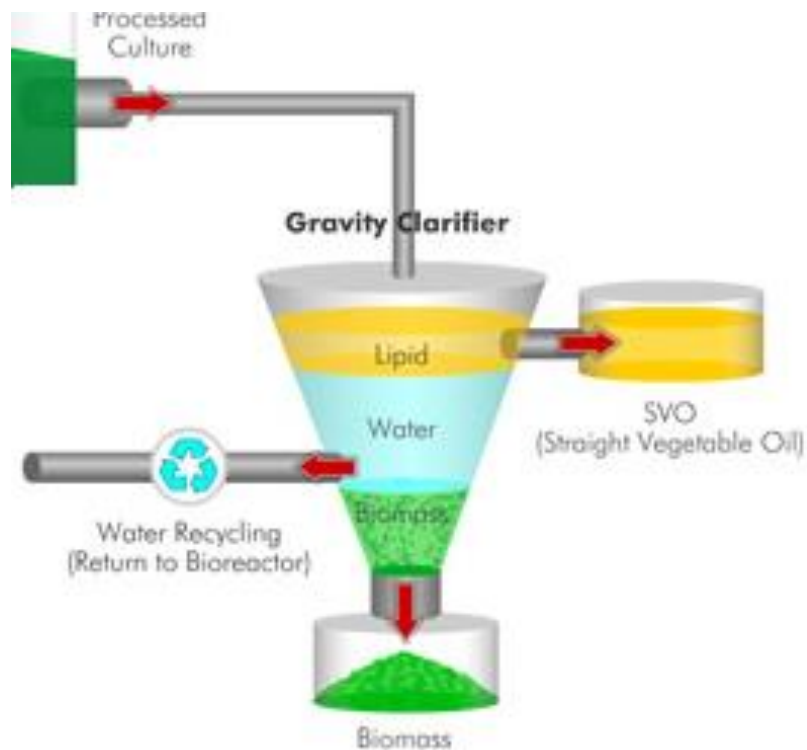

Figure 48. Example decantation process showing the process by which biomass is separated from oil and water (After Sims 2011).

Decantation poses low risk to the environment provided that chemical flocculants are not used to enhance the algae sedimentation rate. Furthermore, because there are no chemical additives, the excess water can be recycled to the cultivation system or released to the environment with minimal additional treatment.

Furthermore, because the process relies on principles of sedimentation and the differences between cell density and growth medium density, electricity input requirements are minimal as well. In some cases, however, the settled biomass is harvested using a vacuum which adds to the electrical power usage. While decantation provides clear environmental and cost benefits, algae recovery performance would not achieve the same solid concentrations as methods such as centrifugation and microfiltration. As a result, decantation and vacuuming are generally considered secondary processes which are implemented in methods such as flocculation, centrifugation, or froth flotation (Ryan 2009). Assessment of decantation performance showed that sedimentation tanks can reach solid concentration levels up to 3% TSS, but have poor reliability for producing desired results (Green, Shelef and Sukenik 1984). The detention rate of the fluid generally ranges from 4 to 12 hours to 2 days depending on throughput requirements of the system (Heber 2013).

(5) **Froth Flotation.** Froth flotation is the process of bubbling air through an algae suspension that creates an algae laden froth on top of the solution that can be harvested. An example of this process is depicted in Figure 49. The term froth flotation can be used to describe two competing types of harvest techniques. Both methods use air induced flotation; the two methods differ in the use of a frothing agent. The frothing agents can increase the amount of algae harvested during the process by up to 70%, but use chemicals that are harmful to human health and the environment. The most important question to answer when considering froth flotation as a potential harvesting technique is whether or not the frothing agents can be safely used in the harvesting process. The use of frothing agents is not recommended for HNAABS based on the need to obtain environmental permits and comply with environmental regulations. Additionally, the potential for a toxic spill is increased with the use of frothing agents. A froth flotation technique limiting the need for frothing agents represents an attractive method for harvesting algae for biofuel production in Hawaii.

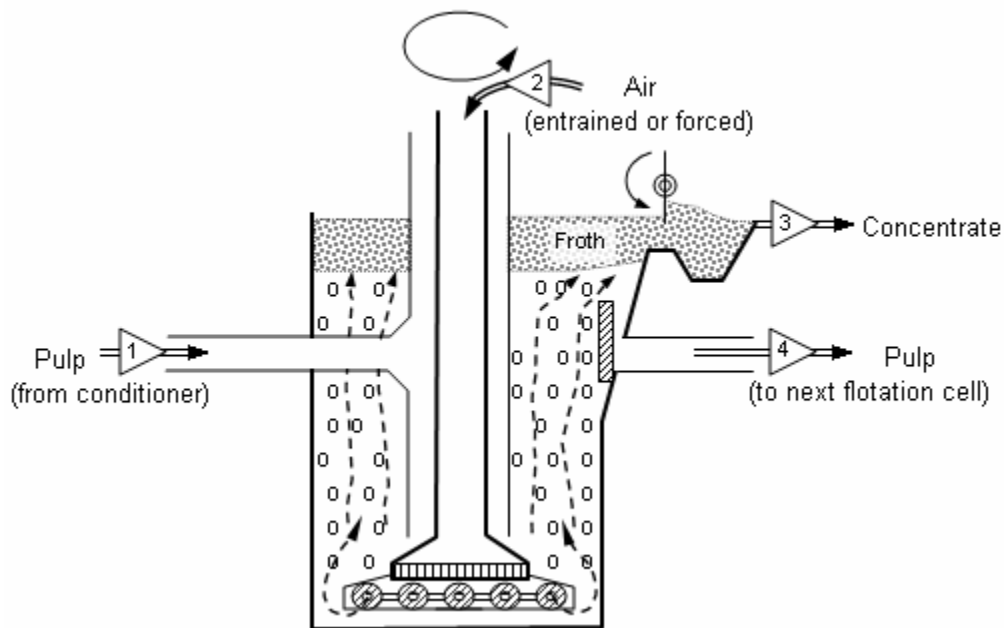

Figure 49. Diagram showing the path of air and concentrated biomass in a froth flotation system (From EnglishInfo 2013).

Froth flotation is most often accomplished by placing the algae solution in a long column that is aerated from the bottom. The aeration produces a foam solution at the top of the column that can be harvested by mechanical or other means. There are many factors that affect the harvest content such as feedstock type, pH, aeration rate, feed concentration, and height of the harvesting column.

Experiments have shown that the froth flotation method as described by Levin readily produces a harvest of 5.9% solids (Bogar, et al. 1961). This is quite high considering the ease with which the method accomplished and the lack of a frothing agent. Furthermore, froth flotation is effective in large scale operations (Bogar, et al. 1961). Using more algae stock in froth flotation will result in a higher concentration of algae in the froth. An additional benefit of eliminating the use of frothing agents in the froth flotation process lies in the fact that the growth medium can be recycled and used for growing more algae.

The cost of a froth flotation system varies depending on the desired size of the system. It can be concluded that the majority of the system cost lies in the

initial installation costs. The operating costs are generally very low and consist mainly of the cost of forced air and the cost of general maintenance of the system. If the system operator desired to have a higher algae harvest content, then the pH of the solution would need to be lowered and the cost of the final product would increase relative to the cost of the acid base solution required to raise and then lower the pH of the algae solution (Bogar, et al. 1961). Relevant system costs, in relation to the froth flotation capacity and power requirements, are provided in Figure 50.

<b>Cost of rectangular, froth-type flotation system</b>				
Capacity		Power requirements (hp)	Costs <sup>a</sup>	
gal/min	bbl/d		Total (\$)	Unit (\$/bbl/d)
150	5,150	13.0	15,600	3.03
300	10,300	21.0	19,800	1.92
450	15,450	31.0	21,500	1.39
750	25,725	41.0	24,750	0.96
1,125	38,585	61.0	35,100	0.91
2,250	77,175	61.0	47,600	0.62
3,000	102,900	81.0	49,000	0.48

Figure 50. Cost of rectangular froth flotation system (From Aulenbach, et al. 2010).

*c. Scoring*

The HNAABS Project Team used an analytical approach to score each of the harvesting alternatives. This AoA process was derived from Naval Postgraduate School coursework as well as the 5<sup>th</sup> edition of *Systems Engineering and Analysis* by Blanchard and Fabrycky. The complete process is described in detail in Section III.A. The team developed a list of prioritized requirements ranking the importance of harvest system attributes as well as rankings for the importance of various design characteristics, system functions, and physical components. The team then developed performance, cost, and environmental rankings to make a final harvest system recommendation.

(1) **Requirements Prioritization.** Prioritized requirement scores were developed utilizing the HNAABS Project Team's perceptions of the importance of each attribute to stakeholders. The analysis results are dependent on these

rankings. As such, the rankings and scores should be reviewed for accuracy. Furthermore, because both the AoA results and associated processes are project deliverables, the analysis can be modified by stakeholders if errors or disagreements are identified in the scoring process. Table 19 shows the final prioritized requirement scores with details regarding the team rationale for each row as follows:

- Row 1. Maximizing the solid percentage (TSS) of the end product was deemed to take precedence over manpower requirements. In fact, based on discussion with USPACOM stakeholders, job creation may be an added benefit of cultivating algae in Hawaii.
- Row 2. Maximizing the solid percentage of the end product was assessed as more critical than minimizing land and ocean surface usage. The harvest process does not require as much land as the growth process and sufficient land should be available such that the team does not consider it a driving factor in the harvest system design.
- Row 3. The team assessed that minimizing energy input was one of the most important factors in choosing a harvest alternative. High energy costs in Hawaii could derail the quest to find an affordable solution to meet algae biofuel production goals. If the process requires too much energy or the infrastructure does not exist, the entire effort could be found to be unfeasible.
- Row 4. Transportation is an issue in Hawaii based on the need to use major roadways for transportation and the difficulty in obtaining permits to build up infrastructure. Transportation is not assessed to be as crucial to the harvesting process as other factors based on the assumption that any transportation would take place after further drying steps. Additional drying would reduce the transportation costs and increase the stability of the biomass during shipment. As a result, maximizing the solid percentage of the algal slurry was given priority over transportation with respect to harvesting.
- Row 5. Environmental factors were brought up repeatedly during discussions with stakeholders as Hawaii is very sensitive to ecosystem impacts. Waste products that cannot be sold or recycled must be treated to allow for release into the environment without adverse effects. This extra process increases the time and money required to harvest the algal biomass and could impact the feasibility of an overall cultivation solution. For this reason, minimizing unusable waste generation was assessed to be slightly more important than maximizing solid content.

- Row 6. Algae harvesting is not a resource intensive process in the same sense as the preliminary algae growth stage. Harvesting does not require sunlight, nutrients, or CO<sub>2</sub>. Instead, the main resources would be any required flocculation agents or the electricity required to perform one of the various harvesting techniques. While resource availability is a factor in terms of electricity infrastructure, it is assumed the location of the facility will be the driving factor and not the specific harvest process. As a result, maximizing solid content was deemed to have greater importance than access to resources.
- Row 7. Maximizing resalable by-products was specifically identified by USPACOM stakeholders as a crucial factor in the algae biofuel production effort. Selling protein and carbohydrate by-products as fish and animal feed can help the local economy by flooding the market and driving down prices for these items. Since the stakeholders seem to have a vested interest in this area, the team scored this factor as slightly more important than maximizing the solid percentage of the harvested biomass.
- Row 8. The team assessed minimizing harvest time to be less important than obtaining higher concentrations of algae in the wet algal biomass. If the process is too fast, it may outpace the actual growth process. Instead, a better solution would be to match the timing to be synergistic with the growth process and choose a harvest process that provides a higher solid percentage of the final slurry concentration.
- Row 9. While it is important to choose an efficient harvesting process, the project remains unfeasible if the harvest process is not scalable to the levels required in this algae biofuel production effort. While there may be opportunity for scale up procedures, this adds to the cost and risk of the cultivation process. At this point, a mature, well-understood harvest process was deemed more important than choosing a highly efficient process in the early stages of development.

Item	Priority Score									Item
Maximize Solid % of Final Slurry Concentration	9	7	5	3	1	3	5	7	9	Minimize Use of Manpower
Maximize Solid % of Final Slurry Concentration	9	7	5	3	1	3	5	7	9	Minimize Land/Ocean Surface Use
Maximize Solid % of Final Slurry Concentration	9	7	5	3	1	3	5	7	9	Minimize Energy Input
Maximize Solid % of Final Slurry Concentration	9	7	5	3	1	3	5	7	9	Maximize Transportation Accessibility
Maximize Solid % of Final Slurry Concentration	9	7	5	3	1	3	5	7	9	Minimize Unusable Waste Generation
Maximize Solid % of Final Slurry Concentration	9	7	5	3	1	3	5	7	9	Maximize Access to Resources
Maximize Solid % of Final Slurry Concentration	9	7	5	3	1	3	5	7	9	Maximize Resalable By-Products
Maximize Solid % of Final Slurry Concentration	9	7	5	3	1	3	5	7	9	Minimize Harvest Time
Maximize Solid % of Final Slurry Concentration	9	7	5	3	1	3	5	7	9	Maximize Scalability

Table 19. Harvest analysis of alternatives requirements prioritization.

(2) **Pairwise Comparison Matrix.** After prioritizing the requirements, the resulting rankings were entered into a relational database called a pairwise comparison matrix, as shown in Table 20. The results of the pairwise comparison calculations provided relative weightings for each of the harvesting criteria assessed in the customer survey. Based on the HNAABS Project Team scoring conventions, maximizing scalability and minimizing energy requirements were assessed to have the greatest importance in developing a feasible algae harvesting system.

Criteria	Criteria	Criteria											10th Roots	Weights
		1	2	3	4	5	6	7	8	10	11			
Maximize Solid % of Final Slurry Concentration	1	1.00	9.00	5.00	0.20	7.00	0.33	5.00	0.33	5.00	0.20	1.43	0.06	
Minimize Use of Manpower	2	0.11	1.00	0.56	0.02	0.78	0.04	0.56	0.04	0.56	0.02	0.16	0.01	
Minimize Land/Ocean Surface Use	3	0.20	1.80	1.00	0.04	1.40	0.07	1.00	0.07	1.00	0.04	0.29	0.01	
Minimize Energy Input	4	5.00	45.00	25.00	1.00	35.00	1.67	25.00	1.67	25.00	1.00	7.13	0.28	
Maximize Transportation Accessibility	5	0.14	1.29	0.71	0.03	1.00	0.05	0.71	0.05	0.71	0.03	0.20	0.01	
Minimize Unusable Waste Generation	6	3.00	27.00	15.00	0.60	21.00	1.00	15.00	1.00	15.00	0.60	4.28	0.17	
Maximize Access to Resources	7	0.20	1.80	1.00	0.04	1.40	0.07	1.00	0.07	1.00	0.04	0.29	0.01	
Maximize Resalable By-Products	8	3.00	27.00	15.00	0.60	21.00	1.00	15.00	1.00	15.00	0.60	4.28	0.17	
Minimize Harvest Time	10	0.20	1.80	1.00	0.04	1.40	0.07	1.00	0.07	1.00	0.04	0.29	0.01	
Maximize Scalability	11	5.00	45.00	25.00	1.00	35.00	1.67	25.00	1.67	25.00	1.00	7.13	0.28	
		0.06	0.01	0.01	0.28	0.01	0.17	0.01	0.17	0.01	0.28	25.48	1.00	

Table 20. Algae harvesting pairwise comparison matrix used to develop weighting factors for system requirements (After Blanchard and Fabrycky 2010).

(3) **Requirements vs. Design Characteristics.** After developing weighted system requirements using the pairwise comparison matrix, the

team developed the first of three HoQ matrices as a part of the QFD process. During this process, requirements were compared with a set of key design characteristics by assigning a rating to the strength of the correlation between the two items being compared. Essentially, this process was used to translate the weighted requirements into a set of key design criteria with associated weights. The scoring convention was as follows:

- 1 = Weak Correlation
- 3 = Moderate Correlation
- 9 = Strong Correlation

The top level design characteristics were carefully chosen to be broad enough to be inclusive of each of the alternative harvest processes. Once the relationship matrix was filled in, performance rankings were calculated for each of the design characteristics. These weighted rankings were based upon the importance of each characteristic in meeting the customer requirements with the rankings skewed towards the customer requirements that were found to be most important in the pairwise comparison matrix. Accordingly, it was no surprise that energy usage, resalable by-products, and the solid content of the slurry output were among the highest ranking design criteria. The full HoQ matrix is shown in Table 21.

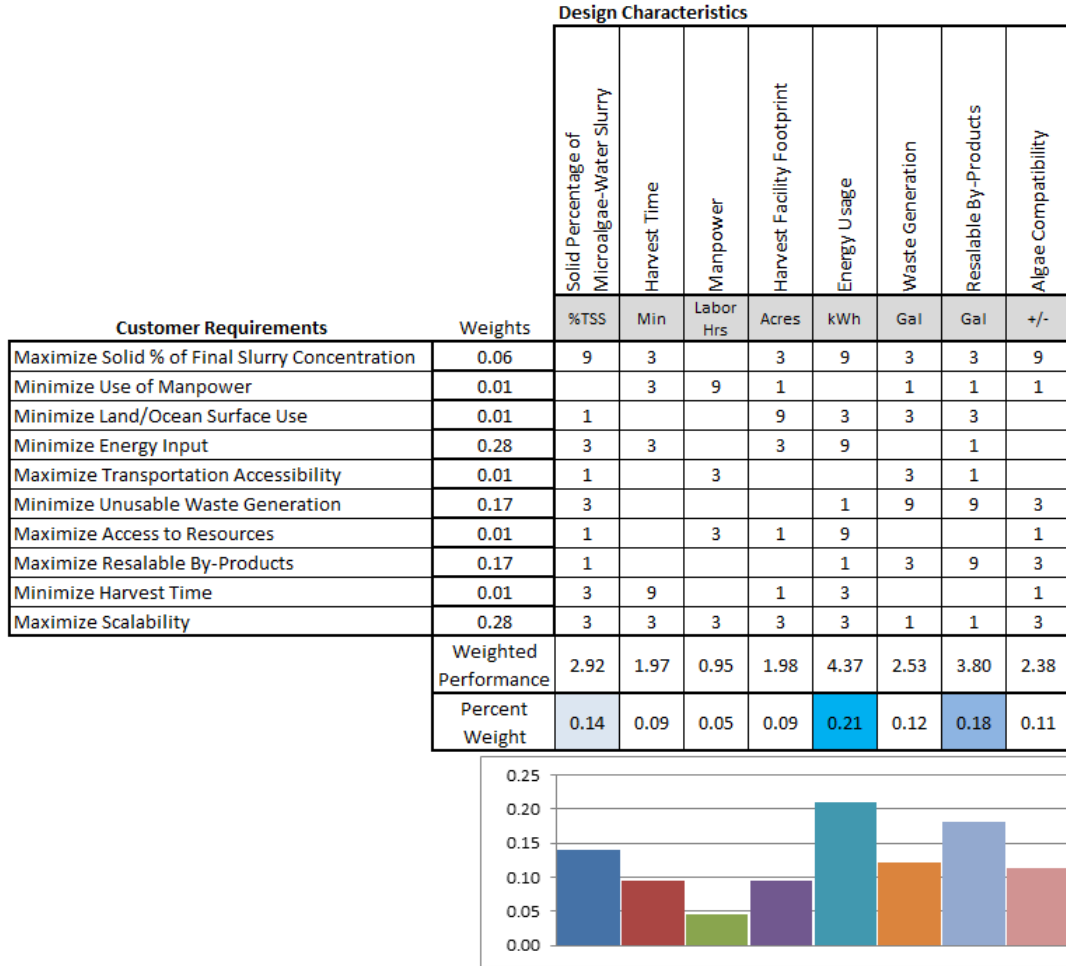

Table 21. Harvest subsystem requirements vs. design characteristics HoQ used to develop weighted rankings for key design criteria.

(4) **Design Characteristics vs. Functions.** A similar process was used in the second HoQ to relate the design characteristics to the functions performed by the harvest system. Again, the functions were decomposed from a generic harvest system in order to include functions associated with each of the potential alternatives. The resulting matrix and weighted rankings are shown in Table 22.

Design Characteristics	Weights	Functions							
		Destabilize Algae Suspension	Collect Algal Biomass	Monitor Harvest Process	Adjust Parameters to Ensure Algae Slurry is within Desired Parameters	Store Micro-Algae Water Slurry	Recycle By-Products	Treat Unusable Waste Products	Transport Biomass
Solid Percentage of Microalgae-Water Slurry	0.14	3	3	3	9				3
Harvest Time	0.09	3	9			3			3
Manpower	0.05		1	9	3				3
Harvest Facility Footprint	0.09		3			9	3	3	
Energy Usage	0.21	3	3	1	1	3	3	3	1
Waste Generation	0.12	3	3				9	9	1
Resalable By-Products	0.18	9	3		3	1	9	9	1
Algae Compatibility	0.11	3	9		3		3	3	
Weighted Performance		3.67	4.16	1.04	2.49	1.94	3.98	3.98	1.35
Percent Weight		0.16	0.18	0.05	0.11	0.09	0.18	0.18	0.06

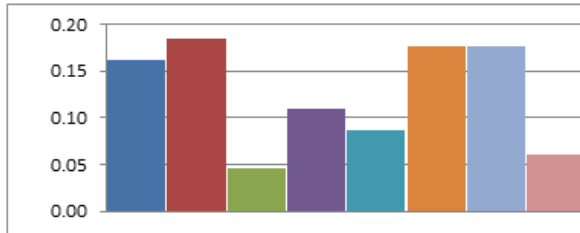

Table 22. Harvest subsystem design characteristics vs. functions used to develop weighted rankings for harvest functions.

Using the same 1-3-9 scoring system to score the correlation between items, weighted rankings were developed for the relative importance of each of the system functions. Destabilizing the aqueous growth medium, collecting the algal biomass, and managing by-products were among the highest ranking functions.

(5) **Functions vs. Physical Components.** The third and final HoQ matrix was developed by mapping the system functionality to the physical components of the Harvest system. The same scoring system and process were used as before. Likewise, the subsystems were chosen at a high level like the previous examples

to avoid skewing the results toward a particular solution. Table 23 shows the resulting HoQ matrix.

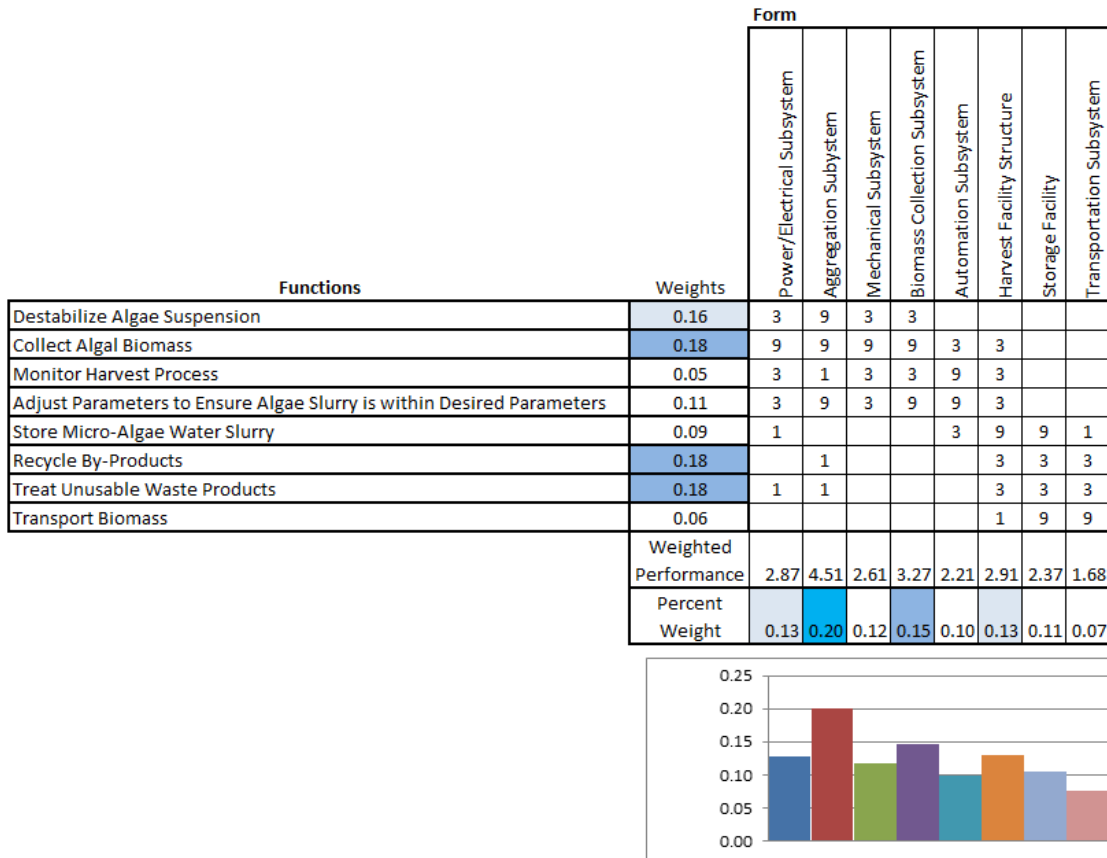

Table 23. Harvest subsystem functions vs. form used to develop weighted rankings for physical components.

After filling in the relationship correlation matrix and tabulating the results, a new set of rankings were developed for the physical subsystems. Higher weights correspond to those physical components that are most associated with performance of the functions that are crucial to meeting the requirements priorities. The results identified the aggregation subsystem, biomass collection subsystem, electrical subsystem, and facility structure as those most related to the requirements priorities.

(6) **Final Performance Weighting.** The weighted subsystem rankings were used as a means of quantitatively assessing the performance of each of the Harvest system design alternatives. Table 24 shows an example of the comparative

analysis that was used in this process. This level of detail allowed there to be performance scores assigned to each of the subsystems.

	Final Slurry Solid %	Product Consistency	Energy Consumption	Algae Compatibility	# of Steps
<b>Centrifugation</b>	22%	Good	Very High	Good	1
<b>Chemical Flocculation</b>	1-3%	Fair	Very Low	Good	2
<b>Microfiltration</b>	18-27%	Good	Low	Fair	1-2
<b>Froth Flotation</b>	6%	Very Good	Moderate	Good	1-2
<b>Decantation</b>	1-3%	Poor	Very Low	Good	1-2

Table 24. Harvest subsystem comparative performance chart.

The team used a 1, 2, 3 scoring method where 1 represents a bad score and 3 represents a good score. The red, yellow, green, color scheme in Table 25 helps illustrate this scoring convention. As an example of how the process worked, the team assessed the score of the electrical subsystem for centrifugation to be a 1. While this subsystem is highly important in the centrifugation process, research showed that centrifugation consumed the most energy of the harvest system alternatives. It was for this reason that the team judged centrifugation to have the worst electrical subsystem score. Likewise, centrifugation does not require the use of chemicals to promote algal cell aggregation even for algae strains with small cell diameters. Therefore, the centrifugation alternative received a better aggregation subsystem score than the other alternatives. The preceding examples illustrate the process by which the Harvest team related system performance to the physical subsystems and alternatives.

	Power/Electrical Subsystem	Aggregation Subsystem	Mechanical Subsystem	Biomass Collection Subsystem	Automation Subsystem	Harvest Facility Structure	Storage Facility	Transportation Subsystem
<b>Performance Weighting</b>	0.13	0.20	0.12	0.15	0.10	0.13	0.11	0.07
<b>Centrifugation</b>	1.00	3.00	1.00	3.00	3.00	1.00	3.00	3.00
<b>Chemical Flocculation</b>	3.00	1.00	3.00	1.00	1.00	2.00	1.00	1.00
<b>Microfiltration</b>	3.00	2.00	1.00	3.00	2.00	3.00	2.00	3.00
<b>Froth Flotation</b>	2.00	2.00	2.00	2.00	2.00	2.00	2.00	2.00
<b>Decantation</b>	3.00	2.00	3.00	1.00	2.00	3.00	2.00	1.00

Table 25. Harvest subsystem alternative performance scores.

After developing the performance scores for each alternative, the scores were multiplied by the subsystem performance weightings identified during the HoQ process and added together to produce an overall system performance score. This methodology was used as a screening process to determine the top alternatives for more detailed final decision analysis provided in Section VI. The results of the Harvest system performance analysis are provided in Table 26.

	0.13	0.20	0.12	0.15	0.10	0.13	0.11	0.07	<b>WEIGHTED PERFORMANCE TOTAL</b>
<b>Centrifugation</b>	0.13	0.60	0.12	0.44	0.30	0.13	0.32	0.22	2.25
<b>Chemical Flocculation</b>	0.38	0.20	0.35	0.15	0.10	0.26	0.11	0.07	1.62
<b>Microfiltration</b>	0.38	0.40	0.12	0.44	0.20	0.39	0.21	0.22	2.36
<b>Froth Flotation</b>	0.26	0.40	0.23	0.29	0.20	0.26	0.21	0.15	2.00
<b>Decantation</b>	0.38	0.40	0.35	0.15	0.20	0.39	0.21	0.07	2.15

Table 26. Harvest subsystem performance results.

Results show that microfiltration is the best option from a performance standpoint based on the prioritization of requirements and the relative scoring used by the HNAABS Harvest team. Microfiltration scored well mainly due to the high slurry solid concentration levels that can be achieved and reduced energy

consumption when compared to other alternatives. Centrifugation was evaluated to be the second best option and a viable alternative based on the similarity of the two scores. Because the scores were so close, sensitivity analysis was performed to understand the effects of changing the stakeholder priorities. Further discrimination between the options is provided in the following sections through analysis of the environmental and cost performance of the system alternatives.

(7) **Environmental Comparison.** To analyze the environmental performance of the candidate harvest technologies, the team utilized a construct similar to the performance process by scoring the systems on a scale of 1 to 3 based on a variety of environmental factors. These factors included items associated with land use, resalable by-products, waste generation and treatment, and electricity utilization. The weights for these items were based on the requirements prioritization process. The weighted rankings for the four requirements associated with environmental factors were normalized so that the weights of those four items added to 100%.

Table 27 shows the results of the environmental analysis with the weighted scores highlighted at the bottom of the graphic. Because the goal was to minimize the effects of the harvest process on the local environment in Hawaii, a lower environmental score was used to represent a superior option. Based on the numbers in the chart, decantation represents the best option due in large part to its low energy requirements. Chemical flocculation, on the other hand, poses the most risk to the Hawaiian ecosystem based on the use of chemical additives that drive additional waste treatment processes and render the protein and carbohydrate byproducts unsuitable for animal or human consumption.

Wt	Parameters and Impacts	Centrifugation	Chemical Flocculation	Microfiltration	Froth Flotation	Decantation
0.10	Land Usage	3	1	2	2	1
0.25	Resalable By-Products	1	3	1	1	1
0.25	Waste Treatment	1	3	1	1	1
0.40	Energy Usage	3	1	1	2	1
Wt	Parameters and Impacts	Centrifugation	Chemical Flocculation	Microfiltration	Froth Flotation	Decantation
0.10	Land Usage	0.30	0.10	0.20	0.20	0.10
0.25	Resalable By-Products	0.25	0.75	0.25	0.25	0.25
0.25	Waste Treatment	0.25	0.75	0.25	0.25	0.25
0.40	Energy Usage	1.20	0.40	0.40	0.80	0.40
Total weight		2	2	1.1	1.5	1

Table 27. Harvest subsystem environmental comparison using prioritized requirements to develop environmental scores.

(8) **Cost Comparison.** The cost comparison in Table 28 shows the results of the harvest team comparative cost analysis. Like the environmental analysis, the cost scores were broken up into relevant categories related to the system complexity, technical risk, maintenance requirements, and capital costs including electrical power and infrastructure costs. Likewise, a lower cost score represents a preferred harvesting option. The results indicate that microfiltration represents the best combination of a mature technology, low technical risk, and low capital costs. Centrifugation, on the other hand, represents the worst option from a cost standpoint based on higher relative infrastructure requirements and higher electricity requirements.

Wt	Parameters and Impacts	Centrifugation	Chemical Flocculation	Microfiltration	Froth Flotation	Decantation
0.10	Complexity	3	1	2	2	1
0.30	Technical Risk	1	3	1	2	3
0.10	Maintenance	2	2	3	2	2
0.30	Capital (Power)	3	1	1	2	1
0.20	Capital (Infrastructure)	3	1	2	2	1
Wt	Parameters and Impacts	Centrifugation	Chemical Flocculation	Microfiltration	Froth Flotation	Decantation
0.10	Complexity	0.30	0.10	0.20	0.20	0.10
0.30	Technical Risk	0.30	0.90	0.30	0.60	0.90
0.10	Maintenance	0.20	0.20	0.30	0.20	0.20
0.30	Capital (Power)	0.90	0.30	0.30	0.60	0.30
0.20	Capital (Infrastructure)	0.90	0.30	0.60	0.60	0.30
Total weight		2.600	1.800	1.700	2.200	1.800

Table 28. Harvest subsystem cost comparison.

(9) **Results.** The final results for the AoA with respect to harvesting algae are provided in Table 29. By laying out cost, performance, and environmental scores in the same graphic, it was possible to easily determine the best solution in each category. Unfortunately, no one solution was best across all factors. As a result, the three scores were used to develop three separate graphics comparing two of the factors against each other in each case. The resulting figures provide a visual representation of the harvest system cost versus performance, cost versus environmental impact, and performance versus environmental impact.

	Results		
	Cost	Performance	Environmental
<b>Centrifugation</b>	2.60	2.25	2.00
<b>Chemical Flocculation</b>	1.80	1.62	2.00
<b>Microfiltration</b>	1.70	2.36	1.10
<b>Froth Flotation</b>	2.20	2.00	1.50
<b>Decantation</b>	1.80	2.15	1.00
<b>Max Possible Score</b>	3.0	3.0	3.0

Table 29. Harvest subsystem final AoA results with raw scores.

In order to make the scores easier to understand on the comparison graphs, the results were normalized using the highest possible score from the comparative analysis. For example, the highest score for the cost analysis would have scored a 3 in every category. The resulting score for this solution, based on the weights provided, would have been a score of 3.0. All the raw cost scores were normalized to this value. A similar process was used for the other two scoring factors. The normalized results are shown in Table 30.

	Results (Normalized)		
	Cost (Lower Better)	Performance (Higher Better)	Environmental (Lower Better)
<b>Centrifugation</b>	0.87	0.75	0.67
<b>Chemical Flocculation</b>	0.60	0.54	0.67
<b>Microfiltration</b>	0.57	0.79	0.37
<b>Froth Flotation</b>	0.73	0.67	0.50
<b>Decantation</b>	0.60	0.72	0.33
<b>Max Possible Score</b>	1.0	1.0	1.0

Table 30. Harvest subsystem final AoA results with normalized scores.

The final scores for each factor of cost, performance, and environmental impact were compared to each other in each dimension. To show which system alternative was the preferred choice a "distance to ideal" value was calculated. This method calculates the distance on the graph to the point on the axis which represents

the ideal solution. In the cost and performance comparison chart, for example, the ideal solution would exhibit a score of 1.0 for performance and a score of 0 for cost. Each alternative was then measured against this ideal value with the resulting scores shown in Table 31.

<b>Lower Score is Better</b>	Environmental vs. Performance	Cost vs. Performance	Cost vs. Environmental
<b>Centrifugation</b>	0.71	0.90	1.09
<b>Chemical Flocculation</b>	0.81	0.76	0.90
<b>Microfiltration</b>	0.42	0.61	0.67
<b>Froth Flotation</b>	0.60	0.81	0.89
<b>Decantation</b>	0.44	0.66	0.69

Table 31. Harvest subsystem distance to ideal results showing the difference between each alternative and the ideal harvest system configuration.

At a quick glance, two options stand out in Table 31: microfiltration and decantation. The highlighted green row indicates that, while the options are close in score, microfiltration appears to have a slight edge. It represents the best option in each of the comparison dimensions. It also represents the best choice from a pure performance and cost standpoint lagging only decantation in environmental impacts. The results are broken down graphically in Figures 51, 52, and 53.

Figure 51 shows the results for the cost versus performance comparative analysis. In this case the ideal solution would score a 1.0 in performance at the lowest possible cost, as indicated by the blue arrow in the chart. Microfiltration provides the best option based on performance as well as cost. Therefore, it can be said that this solution dominates all other alternatives in this particular scenario.

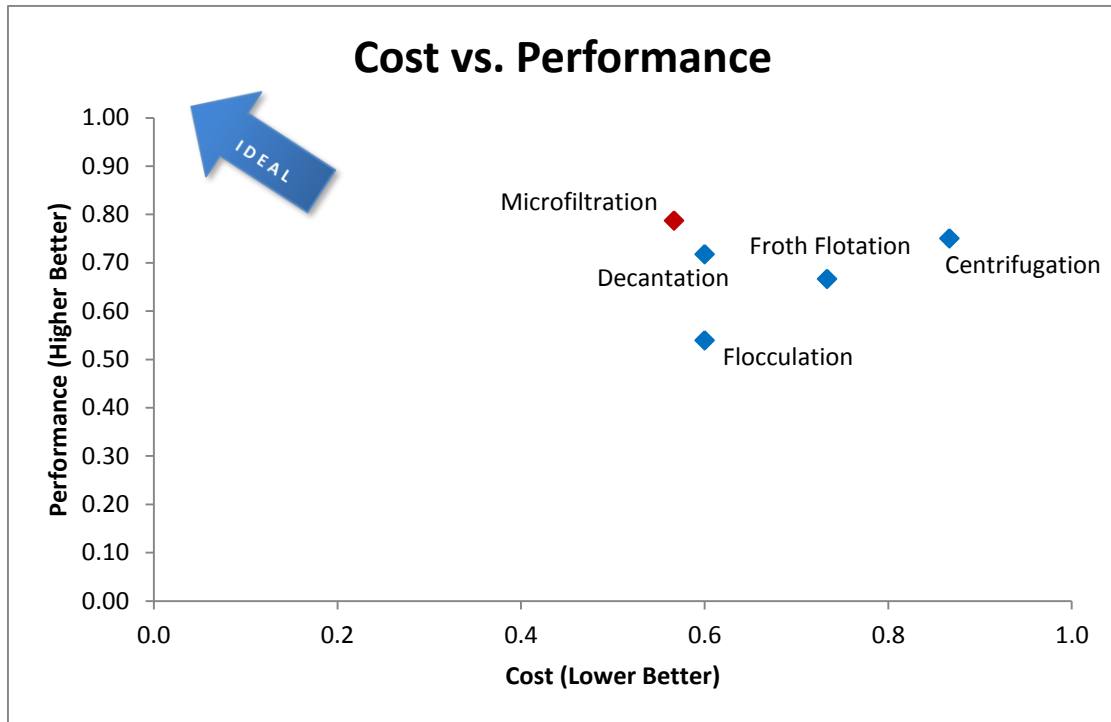

Figure 51. Harvest subsystem cost vs. performance comparison.

Figure 52 shows the cost and environmental comparison results. Microfiltration and decantation both fall on the efficient frontier and, therefore, both represent acceptable options. Microfiltration is the lowest cost option, but decantation provides additional environmental benefits, albeit at a higher cost.

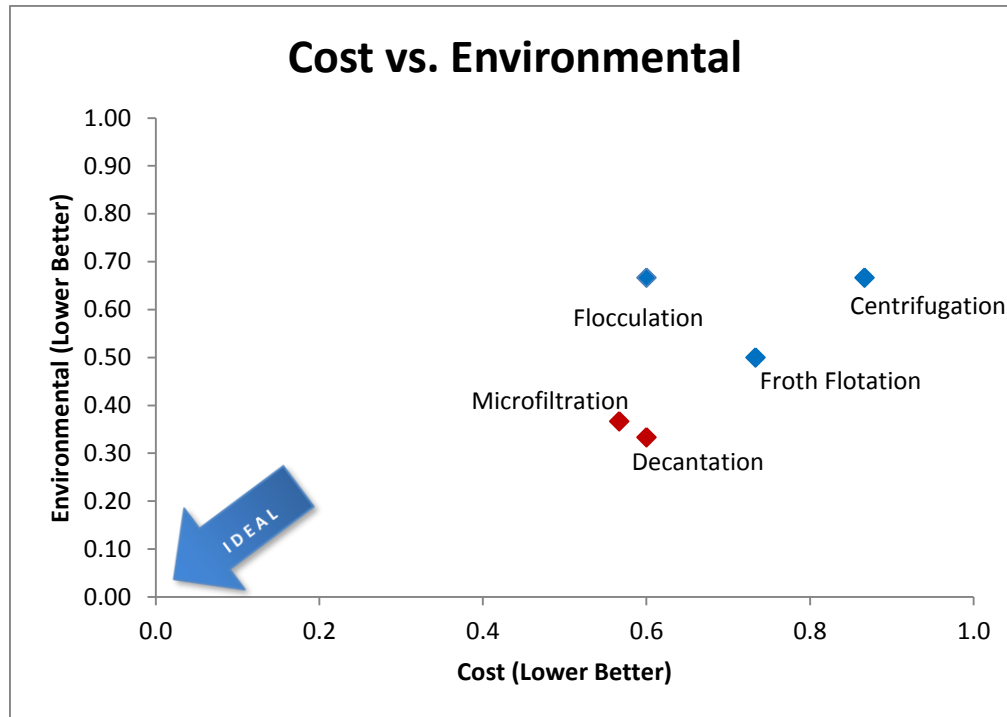

Figure 52. Harvest subsystem cost vs. environmental comparison.

The environmental and performance comparison in Figure 53 shows microfiltration and decantation both fall on the efficient frontier in this case as well. Again, both were considered candidate solutions based on the Harvest team analysis. While decantation is best from an environmental impact standpoint, microfiltration provides some level of increased performance at a higher environmental impact.

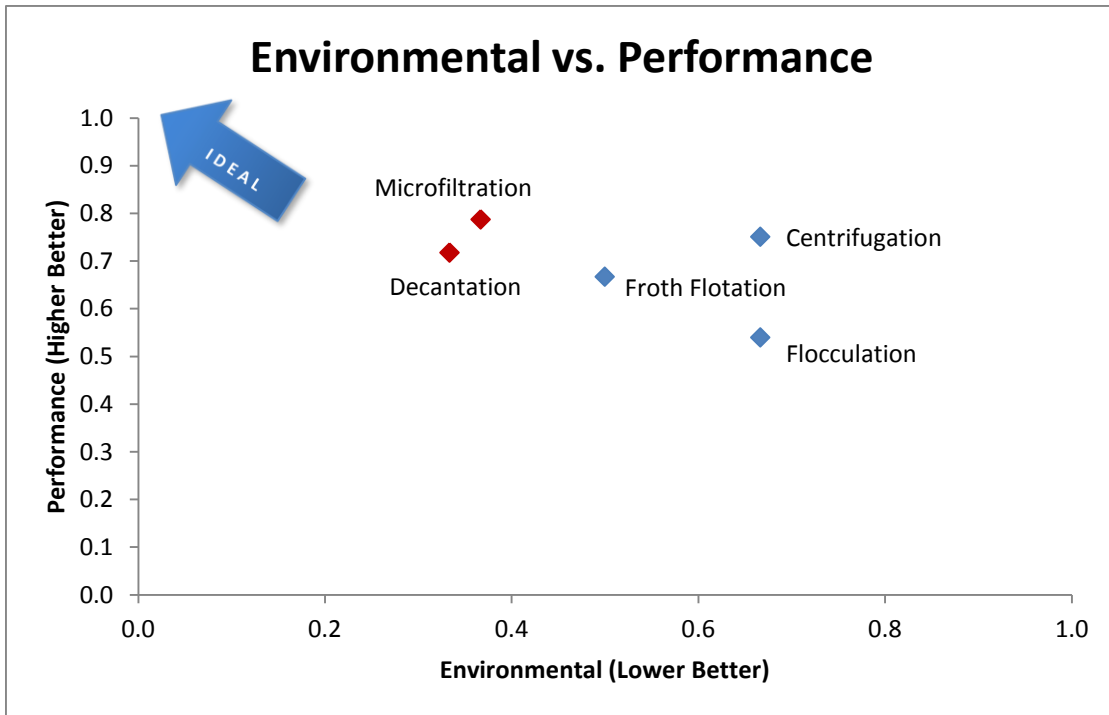

Figure 53. Harvest subsystem environmental vs. performance comparison.

*d. Sensitivity Analysis*

Because the HNAABS Team developed the priority weightings of the system requirements without soliciting inputs from stakeholders, sensitivity analysis was performed to determine the effects of changing the priorities to optimize various characteristics such as resalable by-products and the percentage of solids in the final slurry. Table 32 shows the requirements prioritization process modified to produce a system design placing greater importance on the ability to sell by-products

Item	Priority Score									Item
Maximize Solid % of Final Slurry Concentration	9	7	5	3	1	3	5	7	9	Minimize Use of Manpower
Maximize Solid % of Final Slurry Concentration	9	7	5	3	1	3	5	7	9	Minimize Land/Ocean Surface Use
Maximize Solid % of Final Slurry Concentration	9	7	5	3	1	3	5	7	9	Minimize Energy Input
Maximize Solid % of Final Slurry Concentration	9	7	5	3	1	3	5	7	9	Maximize Transportation Accessibility
Maximize Solid % of Final Slurry Concentration	9	7	5	3	1	3	5	7	9	Minimize Unusable Waste Generation
Maximize Solid % of Final Slurry Concentration	9	7	5	3	1	3	5	7	9	Maximize Access to Resources
Maximize Solid % of Final Slurry Concentration	9	7	5	3	1	3	5	7	9	Maximize Resalable By-Products
Maximize Solid % of Final Slurry Concentration	9	7	5	3	1	3	5	7	9	Minimize Harvest Time
Maximize Solid % of Final Slurry Concentration	9	7	5	3	1	3	5	7	9	Maximize Scalability

Table 32. Prioritized requirements for a design to optimize resalable by-products.

The relationship scores for each of the HoQ diagrams remained unchanged throughout the sensitivity analysis. Likewise, the performance scores based on the physical subsystems did not change. The weighting factors for the design characteristics, functions, and physical components, however, did change as a result of the prioritization changes. Table 33 shows the updated performance weightings based on the new prioritization.

	Power/Electrical Subsystem	Aggregation Subsystem	Mechanical Subsystem	Biomass Collection Subsystem	Automation Subsystem	Harvest Facility Structure	Storage Facility	Transportation Subsystem
Performance Weighting	0.13	0.21	0.11	0.14	0.08	0.13	0.10	0.09
Centrifugation	1.00	3.00	1.00	3.00	3.00	1.00	3.00	3.00
Chemical Flocculation	3.00	1.00	3.00	1.00	1.00	2.00	1.00	1.00
Microfiltration	3.00	2.00	1.00	3.00	2.00	3.00	2.00	3.00
Froth Flotation	2.00	2.00	2.00	2.00	2.00	2.00	2.00	2.00
Decantation	3.00	2.00	3.00	1.00	2.00	3.00	2.00	1.00

Table 33. Performance weighting scores modified to reflect increased focus on resalable by-products.

Cost is an independent variable unaffected by the requirement prioritization changes. As a result, the cost scores did not change during the sensitivity analysis process. The weighted rankings for the environmental impact scores, however, did change based on the new priorities since the weights are derived from the pairwise

comparison matrix. Table 34 shows the updated environmental scores based on the changes to the environmental weighting factors.

Wt	Parameters and Impacts	Centrifugation	Chemical Flocculation	Microfiltration	Froth Flotation	Decantation
0.05	Land Usage	3	1	2	2	1
0.40	Resalable By-Products	1	3	1	1	1
0.40	Waste Treatment	1	3	1	1	1
0.15	Energy Usage	3	1	1	2	1
Wt	Parameters and Impacts	Centrifugation	Chemical Flocculation	Microfiltration	Froth Flotation	Decantation
0.05	Land Usage	0.15	0.05	0.10	0.10	0.05
0.40	Resalable By-Products	0.40	1.20	0.40	0.40	0.40
0.40	Waste Treatment	0.40	1.20	0.40	0.40	0.40
0.15	Energy Usage	0.45	0.15	0.15	0.30	0.15
Total weight		1.4	2.6	1.05	1.2	1

Table 34. Harvest environmental scores modified to reflect increased focus on resalable by-products.

Modifying the system priorities to optimize the design with respect to resalable by-products caused minor changes to the overall system scores. The main outcomes of the process showed that centrifugation and froth flotation exhibited increases in environmental performance. Additionally, centrifugation showed a minimal increase in performance score based on increased importance of the aggregation subsystem. The performance scores changed only slightly based on the new priorities and cost scores were unchanged. The resulting "distance to ideal" metrics are provided in Table 35. The overall results were unchanged as microfiltration still scored best in each of the three comparison metrics.

Lower Score is Better	Environmental vs. Performance	Cost vs. Performance	Cost vs. Environmental
	Centrifugation	0.53	0.90
Chemical Flocculation	0.98	0.76	1.05
Microfiltration	0.41	0.60	0.67
Froth Flotation	0.52	0.81	0.84
Decantation	0.44	0.67	0.69

Table 35. Distance to ideal scores for excursion optimizing resalable by-products.

A second excursion was performed to optimize the system design to maximize the percentage of solids in the algal slurry. The updated priority scores are shown in Table 36.

Item	Priority Score									Item
Maximize Solid % of Final Slurry Concentration	9	7	5	3	1	3	5	7	9	Minimize Use of Manpower
Maximize Solid % of Final Slurry Concentration	9	7	5	3	1	3	5	7	9	Minimize Land/Ocean Surface Use
Maximize Solid % of Final Slurry Concentration	9	7	5	3	1	3	5	7	9	Minimize Energy Input
Maximize Solid % of Final Slurry Concentration	9	7	5	3	1	3	5	7	9	Maximize Transportation Accessibility
Maximize Solid % of Final Slurry Concentration	9	7	5	3	1	3	5	7	9	Minimize Unusable Waste Generation
Maximize Solid % of Final Slurry Concentration	9	7	5	3	1	3	5	7	9	Maximize Access to Resources
Maximize Solid % of Final Slurry Concentration	9	7	5	3	1	3	5	7	9	Maximize Resalable By-Products
Maximize Solid % of Final Slurry Concentration	9	7	5	3	1	3	5	7	9	Minimize Harvest Time
Maximize Solid % of Final Slurry Concentration	9	7	5	3	1	3	5	7	9	Maximize Scalability

Table 36. Excursion to requirements prioritization maximizing the importance of the percentage of solids in the final algal slurry.

Utilizing the same process as the first excursion, the cost scores remained unchanged through the sensitivity analysis and the performance scores did not change enough to affect the overall system results. The differences between each alternative and the ideal system score are provided in Table 37. The results showed that microfiltration remained the preferred system alternative regardless of the excursions to optimize the system for different design characteristics.

Lower Score is Better	Environmental vs. Performance	Cost vs. Performance	Cost vs. Environmental
<b>Centrifugation</b>	0.71	0.90	1.09
<b>Chemical Flocculation</b>	0.81	0.75	0.90
<b>Microfiltration</b>	0.43	0.61	0.67
<b>Froth Flotation</b>	0.60	0.81	0.89
<b>Decantation</b>	0.44	0.66	0.69

Table 37. Distance to ideal scores for excursion optimizing percentage of solids in algal slurry.

Analogous to the Growth subsystem sensitivity analysis, excursions were performed to determine the effects of varying the importance of cost, performance, and environment on the harvest system results. Unlike the growth results, overall the harvest system results were resistant to any changes resulting from design attribute prioritization. When cost and performance rankings were increased, the microfiltration system remained the best alternative for the harvesting subsystem. When environmental impacts were prioritized as the main stakeholder concern, decantation became a better option and overtook microfiltration as the best alternative when environment was given 80% priority as shown in Table 38.

	0.10	0.80	0.10	
	Cost	Env	Perf	3D distance
<b>Centrifugation</b>	0.87	0.67	0.75	0.66
<b>Chemical Flocculation</b>	0.6	0.67	0.54	0.65
<b>Microfiltration</b>	0.57	0.37	0.79	0.38
<b>Froth Flotation</b>	0.73	0.5	0.67	0.51
<b>Decantation</b>	0.6	0.33	0.72	0.36

Table 38. Harvest system sensitivity analysis showing 3-dimensional distance-to-ideal scores when environmental impacts represent 80% of the importance of the overall system.

*e. Recommendations*

After performing sensitivity analysis and reviewing the results in all three comparison dimensions, the preferred selection based on comparative analysis is the microfiltration harvesting method. Microfiltration was assessed to be the best option in relation to cost and performance and the second best option from a purely environmental standpoint. Microfiltration has low energy requirements compared to other design options and allows for recycling of waste water and byproducts.

Centrifugation provides potential for high recovery rates and increased percentages of total suspended solids in the algal slurry, but these benefits are paid for with high capital investment costs and high energy requirements. Froth flotation represents a more economical approach, but this technique generally involves the use of chemical flocculants or frothing agents as a preliminary procedure (Goh, Sim and Becker 1988). Eliminating the use of these chemicals would provide an attractive option from an environmental standpoint, but the performance likely wouldn't meet the minimum 20% TSS HNAABS dewatering process threshold based on study results. In addition, promising flocculation technologies, such as autoflocculation and electroflocculation, could provide low cost harvest options with relatively little environmental risk. These techniques, however, lack the technical maturity to be considered suitable for the HNAABS harvesting process. Research shows that microfiltration has significant advantages in energy utilization, system cost, and chemical usage while recovery rates provide the potential to meet the HNAABS harvest performance requirements. The main obstacle associated with microfiltration results from the fact that microfiltration efficiency is dependent upon the size and composition of the algae being cultivated.

The team recommends selection of microfiltration as the harvesting process for inclusion in the overall HNAABS cultivation system. Because this analysis was completed independently of the other analysis of alternatives efforts, further investigation must be done to ensure the chosen processes from the growth, harvesting, dewatering, and oil extraction phases provide a compatible pathway to a feasible cultivation system. Analysis of the combination of cultivation subsystems is provided in Section V of this report.

#### **4. Dewatering Subsystem Analysis of Alternatives**

##### ***a. Scope and Background***

Dewatering is the third stage of the defined four-phase system investigated through a series of Analysis of Alternatives (AoA). Like the other phases, dewatering is solely dependent upon the input requirements of the extraction phase (fourth-phase) and utilizes the output requirements of the harvest phase (second phase). The algal biomass received from the harvest process is pre-processed to 20% algal concentration, or roughly 80% water, and is Algal Paste at this point. This concentration level has been delineated as an arbitrary interface between system phases to allow this AoA to primarily focus on the drying processes required to obtain at least a 90% algal concentration. The contents and results of the selected alternatives described within the sections to follow demonstrate flash drying as the most effective dewatering solution.

Dewatering of algal biostock is generally defined as the removal of water from algal slurry produced through a harvest process, creating an algal paste. Drying is required to achieve high algal concentrations to facilitate certain oil extraction methods. Some extraction methods require a higher algal concentration ratio, such as Expellers which require dewatered algae; others, such as Ultrasonication (Spendier 2011), can operate successfully on Algae Slurry. For methods accepting a lower algal concentration ratio, or higher percent water, the dewatering phase may be omitted and the algal biostock can be pulled straight from the harvest phase. Additionally, drying algal biostock provides several benefits to the overall process, which include eliminating mass required for transportation and storage while at the same time prolonging the supply by reducing spoilage (Khan 2012).

There are many types of dryers used in drying biomass, including direct- and indirect- fired rotary dryers, conveyor dryers, cascade dryers, flash or pneumatic dryers, superheated steam dryers, solar and microwave dryers. This evaluation focuses solely on methods used to transition Algae Slurry into Algae Paste.

Centrifugal systems are capable of separating water from algae, but are better used as an initial harvesting step as they cannot achieve the level of dewatering

required. Representatives of the HNAABS Team witnessed this method in action at Cellana LLC during a fact finding trip to Hawaii.

Microwave drying shows great potential due to the speed at which the method can dry a sample, the limitations on sample size, and potential power requirements (3900W power source required for a 0.08 m<sup>3</sup> sample) (Wang, et al. 2008) make it unfeasible for high throughput algal biomass dewatering. The water content yielded from microwave drying was suitably low, but the technological maturity was not quite sufficient for the current analysis.

Solar drying is a low energy method for removing water from algae slurry (Kadam 2001). However, this method requires multi-day drying efforts due to the minimal temperature gradient created, requires significant land resources to spread the algae, and still suffers from “questionable lipid stability” (Lardon, et al. 2009) . These factors lead the Team to limiting the dewatering AoA process to including only the following options:

- Rotary dryers
- Conveyor dryers
- Fluidized Bed dryers
- Flash dryers
- Superheated steam dryer

Various combined dewatering methods also exist, though these were not studied as separate options.

(1) **Overview of Methods.** An AoA was performed on the dewatering process for creating algae based biomass containing approximately 5 to 10 percent water. All the methods in the list above are capable of obtaining 5 to 10 percent water in the biomass; less than the 10% threshold. These possible dewatering candidates were evaluated using the criteria generated from the process described in Section III.A.1. The team evaluated different sets of priorities and assessed the impact of those priorities on requirements, the impact of requirements on design characteristics, the impact of design characteristics on system functions, and the impact of functions on system components per the process described in Figure 27.

Because the true priorities are unknown, this AoA followed a repeatable process so that a knowledgeable user could reevaluate this paper’s conclusions using a different set of prioritization inputs. The HNAABS Team chose a set of criteria to demonstrate the process and offer suggestions of other possible sets of user priorities (see Table 39).

(2) **Current Facilities.** Cellana LLC has a dewatering facility in Kona, Hawaii, where they use several steps to dry their algae. The first step, depicted in Figure 54, is a settling tank where the solid biomass sinks to the bottom and the water gets pumped out from the top. The biomass then gets transferred into a centrifuge (Figure 55) where further settling is accelerated via a two-step harvesting process. The biomass then goes through a “ring heater” (Figure 56) that also works like a centrifuge. The final product, dry algae, is then packaged for shipment for the next stage of processing (Figure 57). The goal of the Cellana LLC facility was to sell their cultivation process (a combination of photobioreactors and ponds); dewatering process is considered expensive thus drying speed was their priority.



Figure 54. Settling tanks.



Figure 55. Centrifuge.



Figure 56. Ring heater.



Figure 57. Dry algae.

***b. Development***

For drying to be effective, the dryer alternatives must take into account the three requirements for drying: (1) a source of heat, (2) a method of removing the water

evaporated, and (3) some form of agitation to expose new material. There are two categories for most dryers and it is based upon how the heat is applied to the substrate. In direct dryers, the material receives heat from direct contact with a fluid providing the heat – either hot air or steam. With indirect drying, the material being dried is separated from the heat source by a heat exchange surface. Agitation can occur through various means in either heat category, from pneumatic to structural forces being applied: such as concentrated jets of air, vibration tables, or rotary trommels. The various methods share the common goal to fulfill the three requirements and increase the surface contact area of the algal biomass for rapid evaporation.

Selection of drying equipment depends on the scale of the operation and differs in the extent of capital investment and in energy costs. Most drying systems require exposing the biomatter to hot gases, during the drying process. The heating of this drying gas expends energy that does not increase the energy potential of the resulting fuel product. For this reason, biomass drying poses a problem of major economic importance, accounting for up to 70% of the processing cost.

Using the same methods described in the Growth AoA (see Section III.B.2) our analysis focused on variation within the choice of dewatering method, and kept constant variation outside of the dewatering step. In practice, this means that although the method of harvest can be engineered to reduce water content and the method of refinement can also be engineered to adapt to different levels of water in the end product, it was not part of the process to look at method combinations at this stage. Optimization between the different AoAs is detailed in Section V.

### *c. Alternatives Investigated*

(1) **Fluidized Bed Dryer.** Fluidized Bed dryers are enclosed systems that combine a drying cyclone with a flat drying bed (Figure 58 and Figure 59). Hot gasses pass vertically through the horizontal drying bed, which causes the algae to behave like a fluid, hence the name Fluidized Bed Dryer. The cyclone process is similar to the flash dryer, though the drying time a slightly longer 1-2 minutes compared to 30 seconds (Mujumdar 2006). Heat transfer is relatively high with a fluidized bed, though material clumping can reduce the effectiveness of the process. Various methods of moving the algae, including vibration or rotary agitators can be installed to improve

system performance (Li and Finney 2010). Fine algae particles can be collected in the cyclone and returned to the bed for further drying.

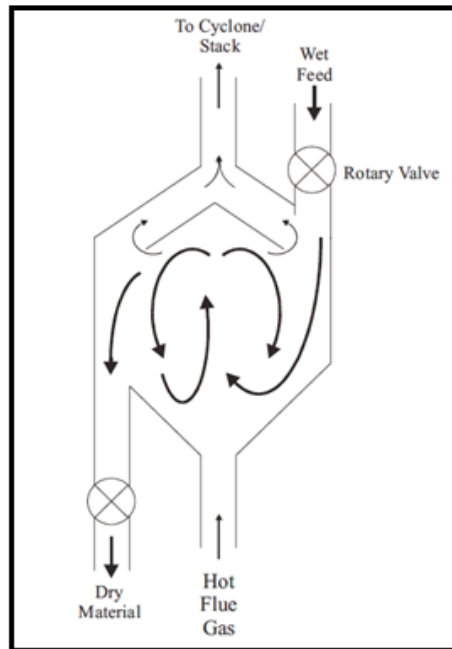

Figure 58. Side view of a cyclone portion of the fluidized bed dryer showing details of the drying methodology (From Amos 1998).

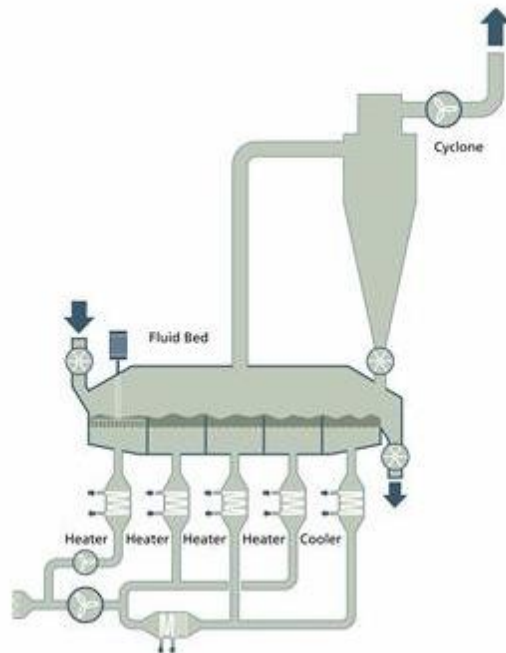

Figure 59. Diagram of the full fluidized bed system. Algae travels along the drying bed before being fine algae particles are launched into the cyclone for drying and recapture (From Li and Finney 2010).

(2) **Conveyor Dryer.** In conveyor dryers, the feedstock is spread onto a continuously moving perforated conveyor to dry the material. Fans blow the drying medium, low pressure stream, residual gas, hot water or hot air, upward or downward through the conveyor and feedstock. Conveyor dryers are very versatile and can handle a wide range of materials. The average drying time for conveyor dryers are upwards of 120 minutes. A screw-type conveyor dryer is shown below in Figure 60.

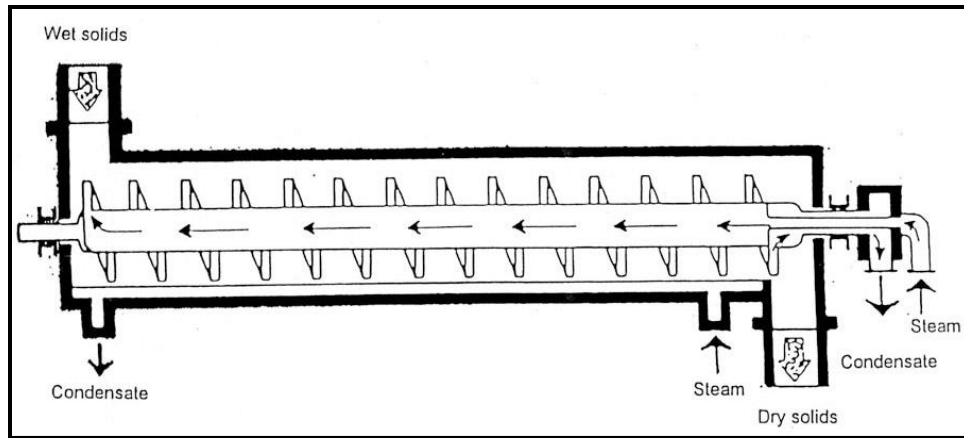

Figure 60. Screw conveyer dryer side view to show system function (From Mujumdar 2011).

Conveyor dryers are better suited to take advantage of waste heat recovery opportunities because they operate at lower temperatures than rotary dryers. Typically, conveyor dryers operate at temperatures between about 200°F and 400°F. Because of their lower operating temperatures, conveyor dryers can be used in conjunction with a boiler stack economizer to take maximum advantage of heat recovery from boiler flue gas.

There is a low fire hazard due to the lower temperatures that conveyors utilize as well as low emissions of Volatile Organic Compounds (VOCs). An advantage conveyor dryers have over many other dryer types is that the material is not agitated. This means there may be fewer particulates in its emissions. On the other hand, fine algae particles may need to be screened out first and added back into the dryer at a later point, because they can fall through the belt's perforations.

The footprint of a single-pass conveyor dryer is typically larger than a comparably sized rotary dryer. Multi-pass conveyors, where conveyors are arranged one above the other with material cascading down from upper conveyors to lower conveyors, save considerable space. Multi-pass dryers are very common in many industries due to their smaller footprint and lower cost.

The capital cost of conveyor dryers and rotary dryers is often comparable (Worley 2011). However, a conveyor dryer may require less ancillary

equipment for treatment of emissions, which could keep the overall cost for new installations at a minimum. Operation and Maintenance (O&M) costs are higher when compared to that of rotary dryers due to the fact that conveyors are slightly more sensitive to operate. The power consumption of conveyor dryers is lower. Multi-pass dryers are more complex than single-pass dryers and so have greater O&M costs than single-pass dryers.

(3) **Flash dryer.** In flash dryers, or pneumatic dryers, the feedstock is suspended in an upward flow of the drying medium, usually flue gas (Roos 2008). These dryers are useful for moist, powdery, granular and crystallized materials, including wet solids discharged from centrifuges, rotary filters and filter presses. The principle of Flash Drying is to evaporate surface moisture instantaneously. A single operation combines the necessary mixing, and heat and mass transfer for drying a solid. Drying time is short, usually less than 3 seconds, and produces almost immediate surface drying. This makes it ideal for drying heat sensitive materials that cannot be exposed to process conditions for extended periods. (Transparent Technologies Private Limited 2012). Algae do not require such special considerations, however, it is important to note that the lower heat exposure does reduce the risk of fires

The heart of the system is a vertical duct, or flash tube, in which the drying takes place and depicted in Figure 61. A fan forces the drying gas (air, or sometimes an inert gas such as nitrogen) through a heater and up through the tube. The feed enters the gas stream, which instantly suspends it and carries it to the collection equipment, usually a cyclone or a bag collector. Cyclones are the least costly means of product collection and will capture the bulk of the solid. However, they often fail to meet required emission limits, so bag filters are often used instead of or in addition to them (Christiansen and Suterardo 2001).

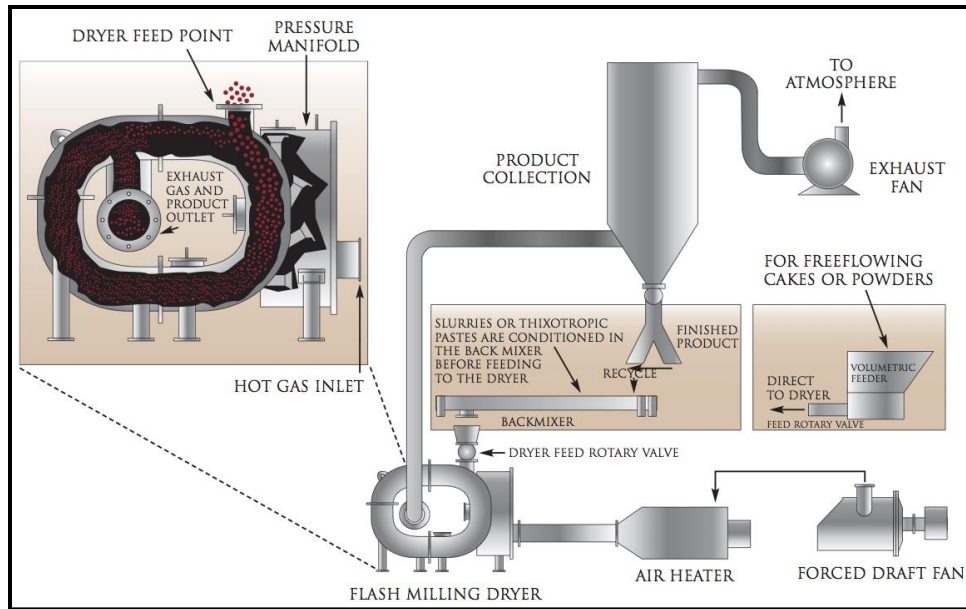

Figure 61. Notional flash milling dryer to show system functionality (From Crown Iron Works Company 2012).

Special designs are used when the large particles are agglomerates of smaller ones held together by surface tension, which is what is expected of the algae after harvesting. Heated low-pressure air is injected into the lower drying chamber via a series of nozzles that enter the dryer on the tangent, setting up a high velocity re-circulating flow of gas. The nozzles are also angled so the exhaust of each nozzle impacts upon the exhaust of the previous nozzle. High velocity collisions between particles occur as a result of the colliding gas streams as well as the eddy currents generated by the natural expansion of the jet of gas. (Christiansen and Suterardo 2001)

Another solution is the ring dryer, which incorporates a centrifugal classifier, or manifold, into the drying loop. The manifold has a series of adjustable deflector blades to control the amount of recirculation within the dryer. The manifold provides selective classification of the larger, wetter particles back to the drying duct for an extended residence time. (Christiansen and Suterardo 2001)

Centrifugal forces generated by the re-circulating gases within the dryer force the larger particles to the peripheral walls. Finer material is displaced towards the inside radius of the dryer where the classifier outlet is located. Fine product exits the

dryer along with the exhaust gas vapor. Larger particles or agglomerates are recycled to the nozzle area dryer for further de-agglomeration and drying (Crown Iron Works Company 2012).

Flash dryers have several advantages over more complex gas-suspension dryers such as fluid-bed or rotary types. The whole process is fully automatic requiring no handling or human involvement. The designs are relatively simple and take up less space, decreasing the required facility footprint (Christiansen and Suterardo 2001). The capital costs of these alternatives are generally lower and maintenance is limited to such components as circulating fans and rotary valves (SPX Corporation 2013). Additionally, low inventory in the dryer allows the control system to respond quickly to operational changes. (Christiansen and Suterardo 2001)

“Flash dryers are generally cost effective only at larger scales” due to power requirements (Roos 2008). Electricity use by a flash dryer is greater than that of other dryer types, because high airflows are required to keep the material suspended. Flash dryers require a small particle size and so shredders may be required, also increasing electrical use (Roos 2008).

(4) **Superheated Steam Dryer.** Figure 62 depicts a notional operation of a superheated steam dryer. Superheated Steam Drying occurs when re-circulated superheated steam is mixed with biomass to dry the biomass. The biomass and superheated steam are separated using a cyclone similar to common flash dryer methods while passing through flash tubing. To provide drying to the next round of biomass, steam can be recycled after it passes through a heat exchanger to bring the temperature back to a functioning level. Latent heat of vaporization is not diluted by air so it can be recovered and condensed directly to recover the heat. This is very beneficial for Superheated Steam Dryers. There are also no air emissions (Worley 2011), the vapor is condensed, including organics, creating a lower fire hazard risk than other dewatering systems because there is no oxidative or combustion reactions possible. However, the wastewater condensate is expected to require treatment. Superheated steam drying also

requires small particle size to allow mixing of steam and particles of biomass (Amos 1998).

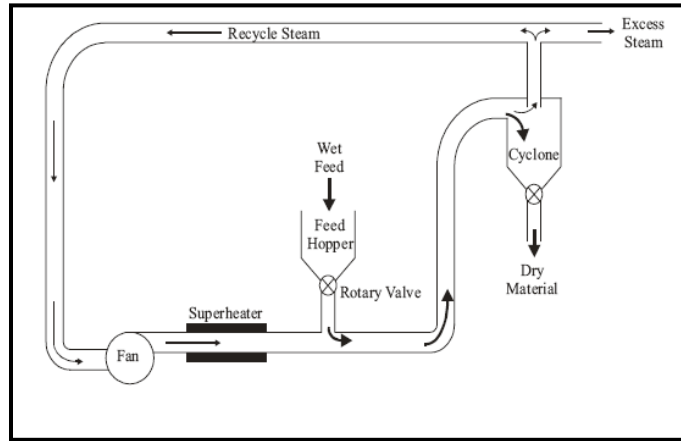

Figure 62. Notional superheated steam dryer showing the major components of system functionality (From Amos 1998).

(5) **Rotary Dryers.** Rotary drying systems tumble the wet biomass particles around a long horizontal cylinder while simultaneously blowing hot gasses across the biomass while it is airborne (Figure 63 and Figure 64). By keeping the mixture partly airborne and constantly moving, this exposes more surface area to the hot gasses, thereby improving the drying performance (Amos 1998). The resulting moisture is controlled by which direction the hot gasses are passed over the liquid biomass. When gasses are passed concurrent with the flow of material, the hottest gasses strike the wettest fluid, thereby increasing the speed of the drying process. If they are passed retrograde, the hottest gasses contact the material where the air moisture content is the lowest, thereby increasing the moisture differential between the biomass and the air, leading to lower end water content. This differential is limited by the flashpoint of the material drying; as highly combustible materials would increase the risk for fire in retrograde drying (Li and Finney 2010). These systems work best on small particle size for the material that is being dried (Amos 1998).

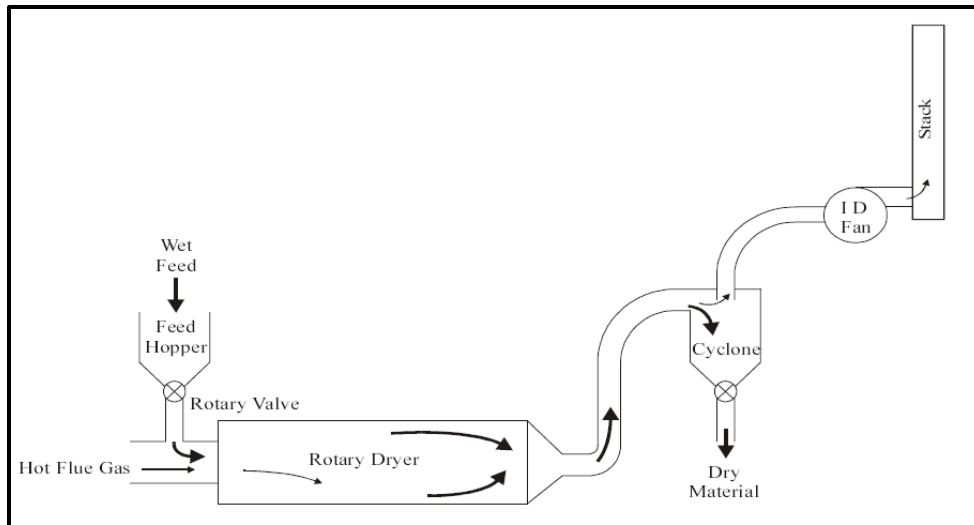

Figure 63. Single-pass rotary dryer (From Amos 1998).

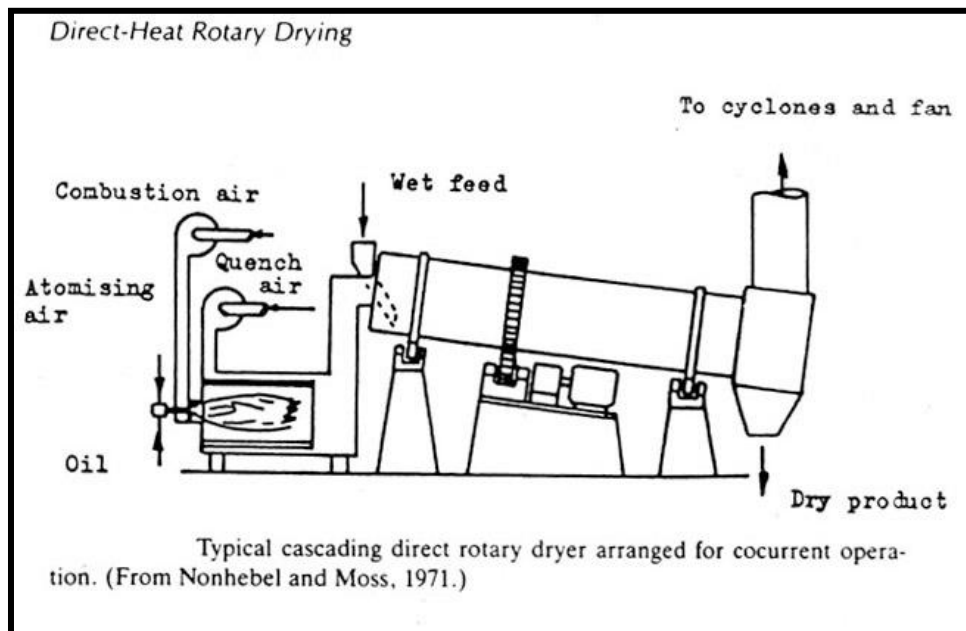

Figure 64. Industrial direct heat rotary drying system design diagram (From Mujumdar 2011).

Rotary dryers are currently available in industrial sizes, reaching 90 meters in length. They work best when the material being dried will not be contaminated by contact with the flue gasses used in the drying process. Designs do exist that use indirect heating by passing the hot gasses through a central tube that heats the biomass through conduction (Mujumdar 2011).

The largest engineering challenge for using rotary dryers is balancing the size needed with the maximum heat that can be used with the material. As they are some of the largest dryers when compared to other dryer systems, the physical space of the facility is a constraint. Although they are large, they are also relatively simple as they contain only simple, slowly turning parts, and a common hot gas generating system. Because the system is relatively simple, this helps to keep maintenance costs and failure rates low. The system can be made more complex by adding multiple passes for the material, which does increase maintenance costs and potential failure mechanisms; however, the improved performance of the dryer may be worth the additional cost by allowing the material to be both more uniformly dry and produced at a more rapid speed. There are significant up front capital costs related to the installation of rotary dryers (Worley 2011) (Amos 1998).

*d. Environmental Considerations*

Overall, all drying methods under consideration apply heat to an organic product. Most involve the free flow of heated gases which can escape into the atmosphere. The water removed from the algae must be captured and disposed of properly, whether extracted as a liquid or a gas. Each method also brings unique environmental issues as well.

(1) **Superheated Steam Drying (SSD).** Because the SSD system must remain closed to allow the creation of superheated steam, there are no air emissions (Worley 2011). The vapor is condensed, including organics, which reduces the fire hazard risk because oxidative or combustion reactions are avoided. However, the wastewater condensate is expected to require treatment due to corrosive materials in the condensed water (Worley 2011). Superheated steam drying also requires small particle sizes to allow mixing of steam and particles of biomass. SSD is reliant on a large power source to create the requisite heat/steam for use in the SSD process (Amos 1998).

(2) **Rotary Dryers.** Rotary dryers present a fire hazard and require the most space infrastructure (Intercontinental Engineer, Ltd. 1980). These systems work best for material with a small particle size. The largest engineering challenge for using rotary dryers is balancing the size needed with the maximum heat that

can be used with the material. As they are some of the largest dryers (up to a 24' diameter x 140' long (Worley 2011), the physical space of the facility is a constraint. Although they are large, they are also relatively simple, as they contain only simple, slowly turning parts, and a common hot gas generating system. Because the system is relatively simple, this helps to keep maintenance costs and failure rates low. The system can be made more complex by adding multiple passes for the material, which does increase maintenance costs and potential failure mechanisms; however, the improved performance of the dryer may be worth the additional cost by allowing the material to be both more uniformly dry and produced at a more rapid speed. One drawback is there are significant up front capital costs related to the installation of rotary dryers (Amos 1998).

(3) **Flash dryers.** Flash Dryers often fail to meet required emission limits so bag filters, a type of air cleaning system, are often used (Mujumdar 2006). Flash dryers have several advantages over more complex gas-suspension dryers such as fluid-bed or rotary types. The whole process is fully automatic requiring no handling or human involvement. The designs are relatively simple and take up less space, decreasing the required facility footprint. The capital cost of these alternatives is generally lower and maintenance is limited to such components as circulating fans and rotary valves. Additionally, low inventory in the dryer allows the control system to respond quickly to operational changes.

Flash dryers are generally cost effective only at larger scales due to power requirements and high installation costs, which can exceed that of a rotary system (Amos 1998). Electricity use of a flash dryer system is greater than that of other dryer types, because high airflows are required to keep the material suspended. Flash dryers require a small particle size and so shredders may be required, also increasing electrical use.

(4) **Fluidized Bed Dryers.** Fluidized Bed Dryers operate at intermediate temperatures between those of conveyor and rotary dryers. They have a smaller footprint than rotary and conveyor dryers, reducing the land capital cost risk. However, Fluidized Bed systems are prone to corrosion and erosion of dryer surfaces and so have a higher maintenance costs. The application of stainless steel is generally

required to combat this corrosion and erosion problem (Li and Finney 2010). Like other air-heated dryers, heat recovery is difficult and expensive, but critical to control air pollution and reduce energy costs (Worley 2011).

(5) **Conveyor Dryer System.** Conveyer dryer systems have issues with debris build up, including tar and fine particulate matter (Worley 2011). Because the system can run at a lower temperature, fire hazards are reduced, and heat recovery efficiency is higher. A larger size increases the facility footprint size.

*e. Scoring*

(1) **Characteristics Prioritization.** The team continued the process described in Section III.A.1 and developed the system characteristics for the dewatering aspect of the cultivation system. The initial comparison of properties of a dewatering system was performed using the standardized comparison scheme shown in Table 39.

Item	Rank									Item
Dewater Biomass	9	7	5	3	1	3	5	7	9	Minimize Manpower
Dewater Biomass	9	7	5	3	1	3	5	7	9	Minimize Drying Cycle Time
Dewater Biomass	9	7	5	3	1	3	5	7	9	Minimize Power
Dewater Biomass	9	7	5	3	1	3	5	7	9	Maximize Batch Volume
Dewater Biomass	9	7	5	3	1	3	5	7	9	Manage Waste Water
Dewater Biomass	9	7	5	3	1	3	5	7	9	Minimal Facility Footprint
Dewater Biomass	9	7	5	3	1	3	5	7	9	Transportation Accessibility

Table 39. Pairwise value comparison score performed by the HNAABS team. Varying prioritizations are shown in light green, dark green, and blue. They can be altered by subject matter experts to suit a different set of program goals.

In Table 39, the yellow cells represent the AoA initial estimate for the relative value of different system goals when evaluating dewatering systems. Using descriptions listed in Table 40, the system parameters were compared to perform this analysis.

Parameter	Description
Dewater Biomass	The end potential water concentration of the dry biomass
Minimize Manpower	The relative number of workers required to operate one unit
Minimize Drying Cycle Time	Time from entry into drying machine to end product
Minimize Power	Electrical power/unit
Maximize Batch Volume	Some systems require batches rather than continuous flow. This was examined as quantity/hour
Manage Waste Water	The ability to contain and direct the waste water
Minimal Facility Footprint	Compared as physical size vs throughput per unit. Less efficient units require greater number and more physical space.
Transportation Accessibility	Ability to collocate facilities

Table 40. Dewater subsystem parameter descriptions. This describes the possible system goals, and their relevant importance in relation to each other.

The initial comparison was based on the assumption that the most important function of the dewatering system was to reduce the end water content as much as possible. Based on this principle the least important aspects (scored 5-left in Table 39) were Manpower, Power, and Waste Water. Any gain in water content reduction was worth approximately a 5-fold decrease in relative performance in either of these areas. Cycle time, transport accessibility, and batch volume were all considered equally important as the end water content, which drove the initial evaluation to balance these four factors (all three scored 1-center). The light green, dark green and blue cells represent the three excursions performed to test the sensitivity of the analysis. For each excursion, the yellow cell scoring remains relevant unless over-ridden by one of the green or blue cells. Dark green cells represent a focus on environmental concerns, light green cells represent a focus on minimizing the land footprint, and the blue cells represent a focus on cost implications. Should the stakeholder have different priorities, another set of rankings could be fed into this analysis. The analysis process itself would not change, only the results based on the new value criteria.

(2) **Pairwise Comparison Matrix.** Using the requirements projected in the first step, the design characteristics were pairwise compared against each other to determine the relative weighting of each for use in evaluating the importance of the design characteristics. The pairwise comparison is shown in Table 41.

Design Characteristics										
		Dewater Biomass	Minimize Manpower	Minimize Drying Cycle Time	Minimize Power	Maximize Batch Volume	Manage Waste Water	Minimal Facility Footprint		
Design Characteristics		1	2	3	4	5	6	7	7th Roots	Weights
Dewater Biomass	1	1.00	5.00	1.00	5.00	1.00	5.00	3.00	2.10	24%
Minimize Manpower	2	0.20	1.00	0.20	1.00	0.20	1.00	0.60	0.51	6%
Minimize Drying Cycle Time	3	1.00	5.00	1.00	5.00	1.00	5.00	3.00	2.10	24%
Minimize Power	4	0.20	1.00	0.20	1.00	0.20	1.00	0.60	0.51	6%
Maximize Batch Volume	5	1.00	5.00	1.00	5.00	1.00	5.00	3.00	2.10	24%
Manage Waste Water	6	0.20	1.00	0.20	1.00	0.20	1.00	0.60	0.51	6%
Minimal Facility Footprint	7	0.33	1.67	0.33	1.67	0.33	1.67	1.00	0.80	9%
		25%	5%	25%	5%	25%	5%	8%	8.63	100%

Table 41. Dewater subsystem pairwise comparison matrix. The table compares the design characteristics against each other to determine their relative weighting of importance.

The most important requirements based on the primary weighting scheme are Dewatering Biomass, Minimizing Drying Cycle Time, and Maximizing Batch Volume. The Dewatering Biomass was considered important as the lower the water content in the final dry algae the less chance there is of spoilage. Additionally, water has corrosive effects on the refinement process (Easterly 2002) (Vardon, et al. 2011). The longer the biomass remains in the drying stage, the more temporary storage capacity must be procured, and if the dewatering system is too slow, the growth system will not be able to operate at optimal efficiency. Adding additional drying units to improve speed adds cost; therefore, process speed was determined to be a top priority. This same logic applies to the assessment of Batch Volume. In this way, the team sought to focus on both these parameters to improve throughput. The numeric weights give a quantitative scoring system to the qualitative assessment described in the Characteristics Prioritization section above.

(3) **Requirements to Design Characteristics Allocation.**

Design characteristics specific to the dewatering process were established and weighed against the requirements. Using the same HoQ scoring system used in the other AoAs, a weighted score of nothing, 1, 3, or 9 were given to each design characteristic with respect

to the requirements priorities; nothing meaning not applicable, 1 meaning little correlation and 9 meaning high correlation between the requirement and the characteristic of design. For example, the final percent water in the biomass has a high correlation with the amount of waste water produced. Although the drying time strongly correlates to minimizing the drying time requirement, it only moderately correlates to the actual percentage of water in the biomass as one hour of drying is not equal in effect between the different methods. The team assigned a slight correlation to the goal of Minimizing Power to the Biomass Drying Time characteristic. The Team assumed the facility would operate a normal work day, but excessively long drying time could expand those hours and impact the energy usage of the facility. Once the weighted scores were established, weighted performance or percent weights were calculated for each design characteristic (Table 42).

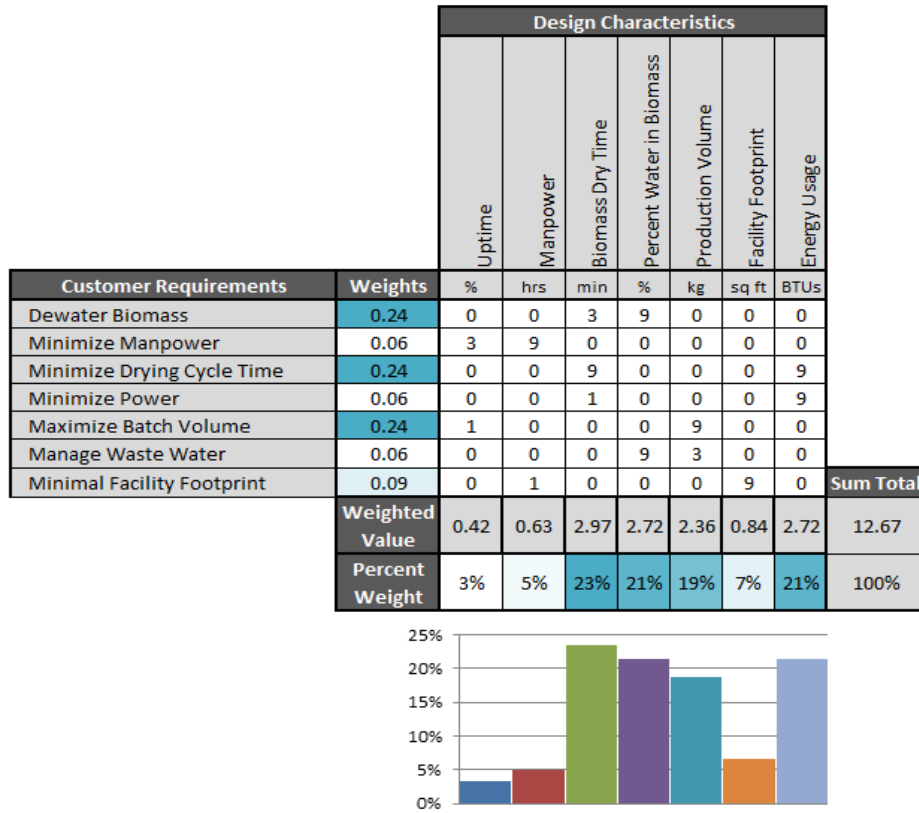

Table 42. Dewater subsystem requirements priorities vs. design characteristics. This step of the HoQ process relates which measures of design quality (Characteristics) affect which final stakeholder requirements.

Biomass Dry Time resulted in the highest weighted design characteristic. Multiple aspects of dewater method design impact the speed in which biomass is dried. The second highest weighted design characteristics were Percent Water in Biomass and Energy Usage. Energy Use affects the goal of Minimizing Time and Power, where the end water percentage governs our top requirement of minimizing water in the biomass as well as the volume of waste water produced by the facility. The rest of the design characteristics were weighted as follows, from highest to lowest: Production Volume, Facility Footprint, Manpower.

(4) **Design Characteristics to Functions Allocation.**

Functions specific to the dewatering process were established and weighed against the design characteristics. Similar to the previous section, a weighted score of nothing, 1, 3,

or 9 were given to each function with respect to the design characteristics. The scoring is identical in process to the previous step. Once weighted scores were established, weighted performance or percent weights were calculated for each function (Table 43).

Design Characteristics	Weights	Functions									Sum Total
		Prepare Dewatering Station	Start Dewatering Method	Maintain Dewatering Method	Operate Dewatering Method	Collect Method Output	Analyze Method Output	Store Method Output	Transport Method Output	Remove Waste Product	
Uptime	3%	1	3	9	1	3	0	1	1	1	
Manpower	5%	9	1	1	1	1	1	0	1	1	
Biomass Dry Time	23%	0	0	1	9	9	0	0	0	0	
Percent Water in Biomass	21%	0	0	1	9	3	9	3	0	0	
Production Volume	19%	0	0	1	3	9	3	9	3	9	
Facility Footprint	7%	1	0	1	0	1	0	9	3	1	
Energy Usage	21%	1	3	3	9	3	1	1	3	1	
<b>Weighted Value</b>		0.76	0.79	1.70	6.62	5.30	2.76	3.17	1.49	2.04	24.62
<b>Percent Weight</b>		3%	3%	7%	27%	22%	11%	13%	6%	8%	100%

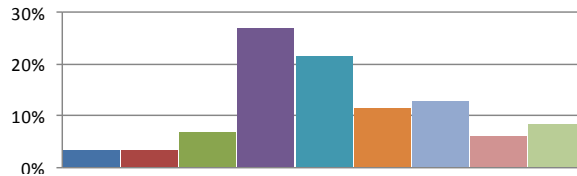

Table 43. Dewater subsystem design characteristics vs. functions. This matrix performs a similar comparison as the previous figure, this time relating system functionality to design measures (Characteristics). The resultant weighting shows the relative value of each system function to the user.

As with previous steps, the correlation assessment is heavily based on team judgment. Subject Matter Experts can modify the strength of correlation between these factors as desired, but the main goal is to demonstrate the success of the AoA comparison methodology. Based on the correlation assessment, the Team found that the factors related to the collection and storage of the output was most important for the design. To give some examples of this logic, the HNAABS Team determined the ability to successfully analyze the output biomass had a great impact on the dewatering facility's

ability to ensure the end water content requirements are met. However, this requirement was unaffected by the collection step of this process because the collection of the dry biomass should neither require energy, nor be capable of altering the end water content.

The functions were weighted as follows, from highest to lowest:

- Operate Dewatering Method
- Collect Method Output
- Store Method Output
- Transport Method Output
- Maintain Dewatering Method
- Analyze Method Output
- Remove Waste Product
- Prepare Dewatering Station
- Start Dewatering Method.

(5) **Functions to Subsystem Allocation.** Forms specific to the dewatering process were established and weighed against the design Functions. The forms represent the physical systems of the Dewatering System where the Functions represent the process performed to the system in order to make the system work. A matrix of Functions vs. Forms were created and weighed against each other in a Null, 1, 3, and 9 formats, as done in the previous section. Once weighted scores were established, weighted performance and percent weights were calculated for each function (Table 44). These weights indicate the criticality to the final system form for each system function. This information drives the selection of hardware to satisfy the user's functional requirements.

Functions	Weights	Form							Sum Total
		Drying Facility	Power Supply	Heat Supply	Drying Equipment	Environmental Control	Monitoring System	Packaging System	
Prepare Dewatering Station	3%	3	3	3	9	1	1	1	
Start Dewatering Method	3%	9	9	3	9	0	3	0	
Maintain Dewatering Method	7%	3	3	3	9	1	9	0	
Operate Dewatering Method	27%	3	9	9	9	3	9	0	
Collect Method Output	22%	3	0	0	3	1	0	3	
Analyze Method Output	11%	1	1	0	1	1	1	1	
Store Method Output	13%	0	1	0	0	1	0	9	
Transport Method Output	6%	0	3	0	0	3	0	3	
Remove Waste Product	8%	3	1	0	1	9	3	3	
	<b>Weighted Value</b>	2.40	3.51	2.82	4.45	2.29	3.53	2.38	21.38
	<b>Percent Weight</b>	11%	16%	13%	21%	11%	17%	11%	100%

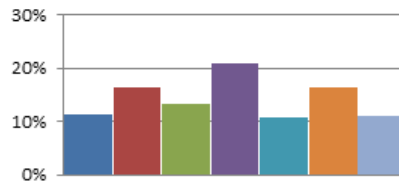

Table 44. Dewater subsystem functions vs. form. Continuing the process, this matrix relates what physical structure (Form) controls which input function. The final weighting prioritizes the subsystem hardware by its relative impact on the end user's goals.

There were seven different forms identified for the dewatering subsystem to include Drying Facility, Power Supply, Heat Supply, Drying Equipment, Environmental Control, Monitoring System, and Packaging System. The weighting system was applied to each of the Function vs. Form combinations. The resulting information was tallied together to form a Percent Weight percentage that ranged anywhere from 11% to 21% as shown in Figure 44. Examples of the logic used are assuming the drying equipment itself had a strong impact on the front end of the dewatering facility, but little impact on the collection and storage of the resulting product. In contrast, the environmental concerns mostly revolve around the facilities outputs rather than the facilities inputs. As with the previous section, this scoring is somewhat

subjective and only actual inputs from a SME tasked with evaluating a specific proposal should be considered final.

(6) **Final Performance Weighting.** Given the weighed importance of each form, the chosen alternatives were assessed by their sub component's performance (Table 45). A matrix was created that took each Alternative (Fluidized Bed, Conveyor, Flash, Superheated Steam, and Rotary) and mapped a block to each Form found.

		Alternatives				
		Fluidized Bed	Conveyor	Flash/Ring	Superheated Steam	Rotary
Wt	Parameters and Impacts					
11%	Drying Facility	2	1	3	1	2
16%	Power Supply	3	2	1	2	2
13%	Heat Supply	1	2	2	3	2
21%	Drying Equipment	1	1	3	3	1
11%	Environmental Control	2	2	2	1	2
17%	Monitoring System	3	2	3	1	2
11%	Packaging System	3	2	3	2	2
		↓	↓	↓	↓	↓
	Drying Facility	0.2	0.1	0.3	0.1	0.2
	Power Supply	0.5	0.3	0.2	0.3	0.3
	Heat Supply	0.1	0.3	0.3	0.4	0.3
	Drying Equipment	0.2	0.2	0.6	0.6	0.2
	Environmental Control	0.2	0.2	0.2	0.1	0.2
	Monitoring System	0.5	0.3	0.5	0.2	0.3
	Packaging System	0.3	0.2	0.3	0.2	0.2
	<b>Total Weighted Value</b>	2.1	1.7	2.4	2.0	1.8

Table 45. Dewater subsystem performance comparison. The subsystems within each alternative are compared against each other, and a qualitative low, medium, high ranking was assigned. When the cross product of each ranking and performance weight is calculated, the sum of these values gives a normalized performance score to each subsystem.

The weighting system used a 1, 2, and 3 format, which translate to low, medium, and high performance respectively. As with previous AoAs, greater quantity is always ranked numerically higher than less quantity of a particular

characteristic. The most performance, most cost, and most environmental impact all receive the highest score of 3. This causes the ideal score to vary based on if the goal is to maximize or minimize the value in question. The previous Functions vs. Form Percent Weight found in Figure 44 were used in the Performance weighting to calculate the overall Performance Total. Each of the alternatives compared show a range between 1.7 and 2.4 for their respective Performance Total as seen in Figure 45. The results of the calculated Performance total shows that the conveyor has the least performance where the Flash Dryer shows the best (highest) performance for the system.

(7) **Cost and Environmental Weighting.** The cost comparisons, in Table 46, show Flash dryers having the lowest (Best) cost risk, with superheated steam systems scoring the highest (worst). Infrastructure and land requirements for superheated steam and ring/rotary methods make the two methods cost prohibitive as dewatering methods (Worley 2011).

		Alternatives				
		Fluidized Bed	Conveyor	Flash	Superheated Steam	Rotary
Wt	Parameters and Impacts					
30%	Complexity & Technical Ris	1	2	1	3	2
20%	Manpower & Specializatio	2	2	2	3	2
25%	Capital (Power)	3	1	3	3	1
25%	Capital (Land)	1	3	1	1	3
		↓	↓	↓	↓	↓
	Complexity & Technical Ris	0.3	0.6	0.3	0.9	0.6
	Manpower & Specializatio	0.4	0.4	0.4	0.6	0.4
	Capital (Power)	0.8	0.3	0.8	0.8	0.3
	Capital (Land)	0.3	0.8	0.3	0.3	0.8
<b>Total Weighted Val</b>		<b>1.7</b>	<b>2.0</b>	<b>1.7</b>	<b>2.5</b>	<b>2.0</b>

Table 46. Dewater subsystem alternatives cost comparison.

The environmental comparisons, in Table 47, show minimal difference between cascade, conveyor and flash dryer methods. The conveyor method is the preferred method for recyclable water considerations. Flash dryer has good ratings for all aspects. The Cascade method is preferred for the land aspect and has the lowest overall rating by a minimal margin. SSD and rotary dryer methods are both undesirable due to their large infrastructure and land use. Additionally, SSD also has poor wastewater effects.

		Alternatives				
Wt	Parameters and Impacts	Fluidized Bed	Conveyor	Flash	Superheated Steam	Rotary
40%	Land Usage	1	2	1	1	3
15%	Water Consumption	1	2	1	2	2
15%	Water Waste	2	1	1	3	2
15%	Energy	3	1	3	2	2
10%	Ecosystem	2	2	2	1	2
5%	Air	2	2	2	1	2
		↓	↓	↓	↓	↓
	Land Usage	0.4	0.8	0.4	0.4	1.2
	Water Consumption	0.2	0.3	0.2	0.3	0.3
	Water Waste	0.3	0.2	0.2	0.5	0.3
	Energy	0.5	0.2	0.5	0.3	0.3
	Ecosystem	0.2	0.2	0.2	0.1	0.2
	Air	0.1	0.1	0.1	0.1	0.1
	<b>Total Weighted Value</b>	1.6	1.7	1.5	1.6	2.4

Table 47. Dewater subsystem alternatives environmental comparison.

(8) **Results.** Flash drying was the best rated system for cost, environmental, and performance aspects. The fluidized bed dryer tied for the top spot in the cost analysis. Table 48 depicts the raw scores for each factor, and is color weighted with the more favorable choices to be seen as green.

Alternatives	Results		
	Cost	Performance	Environmental
Fluidized Bed	1.70	2.10	1.60
Conveyor	2.00	1.68	1.70
Flash	1.70	2.43	1.45
Superheated Stea	2.50	1.96	1.60
Rotary	2.00	1.79	2.40

Table 48. Dewater subsystem raw scoring results comparison.

By comparing each individual score to a “perfect” score, one could normalize the data to better depict the results. Table 49 shows the normalized scoring data in similar formatting and includes analysis for selection as a function of the comparison data point to its respective ideal value.

Alternatives	Results			Distance to Ideal			Ideal X Ideal Y
	Cost	Performance	Environmental	Perf vs Envr	Perf vs Cost	Envr vs Cost	
Cascade	0.57	0.70	0.53	0.61	0.64	0.78	0 1
Conveyor	0.67	0.56	0.57	0.72	0.80	0.87	0 0
Flash	0.57	0.81	0.48	0.52	0.60	0.74	0 0
Superheated Stea	0.83	0.65	0.53	0.64	0.90	0.99	0 0
Rotary	0.67	0.60	0.80	0.90	0.78	1.04	0 0

Table 49. Dewater subsystem normalized scoring results comparison.

A significant relationship developed between the system size and the system power requirements. Larger systems were more energy efficient to operate. The HNAABS Team opted for the smaller, more energy intensive system because although power use was higher, overall performance and environmental impact was better. Should power consumption be a greater priority, a larger, slower dryer could be used.

As previously discussed, the normalized data for each factor was analyzed and presented as a comparison amongst the other factors for individual trade-offs (i.e., cost vs. performance). Figures 65, 66, and 67 show such relationships to include: environmental versus performance, cost versus performance, and cost versus environmental, respectively. When comparing the alternatives in this manner, one can appreciate the implications of individual strengths and weaknesses of the data tabulated to this point.

The efficient frontier, or alternatives that are not dominated by a better selection in either axis, are highlighted in ‘red’ and circled. These points are the data unique alternatives for the given comparisons in the figures below. For all charts, the flash system was on the efficient frontier. The fluidized bed system is also included for the performance vs. cost graph, as it had high performance characteristics and better cost risk than the flash dryer.

From the data, the flash dryer alternative has the overall closest to ideal scoring for environmental versus performance and cost versus performance making this the number one choice. Although energy consumption is higher, the HNAABS Team believes the improved performance is worth the added cost. Because this same value judgment may not be made in every situation, trade space analysis methodology has been described for the stakeholders to prioritize their specific concerns and make the best “bang for your buck” decision.

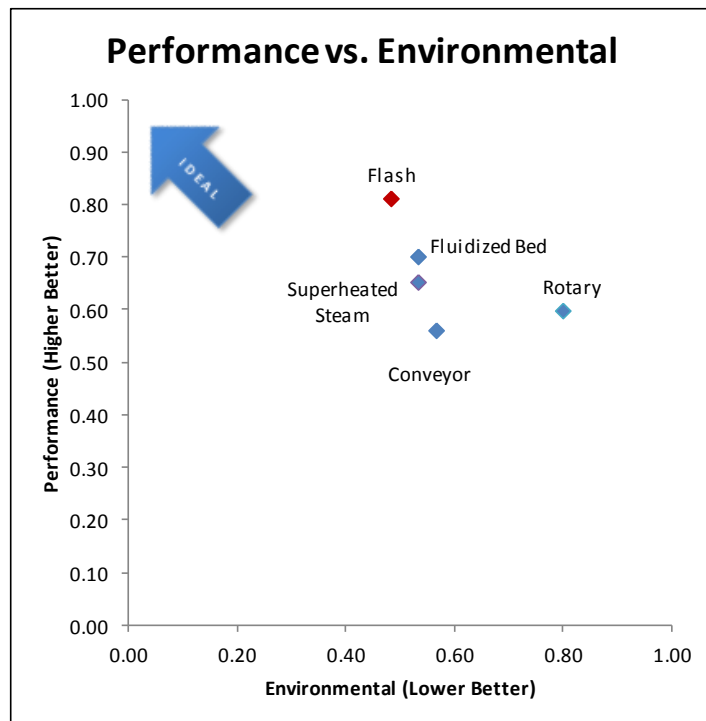

Figure 65. Dewater Subsystem Environmental vs. Performance Comparison

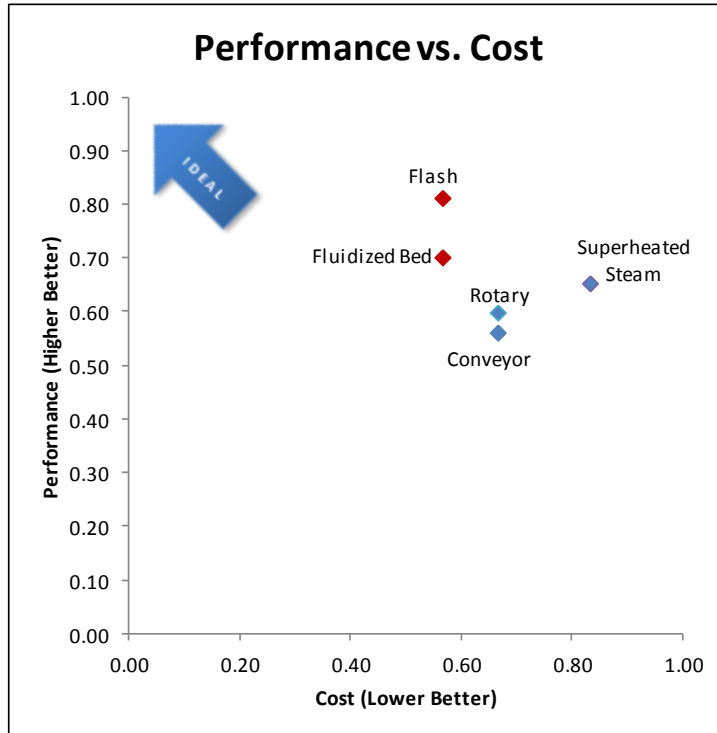

Figure 66. Dewater subsystem cost vs. performance comparison.

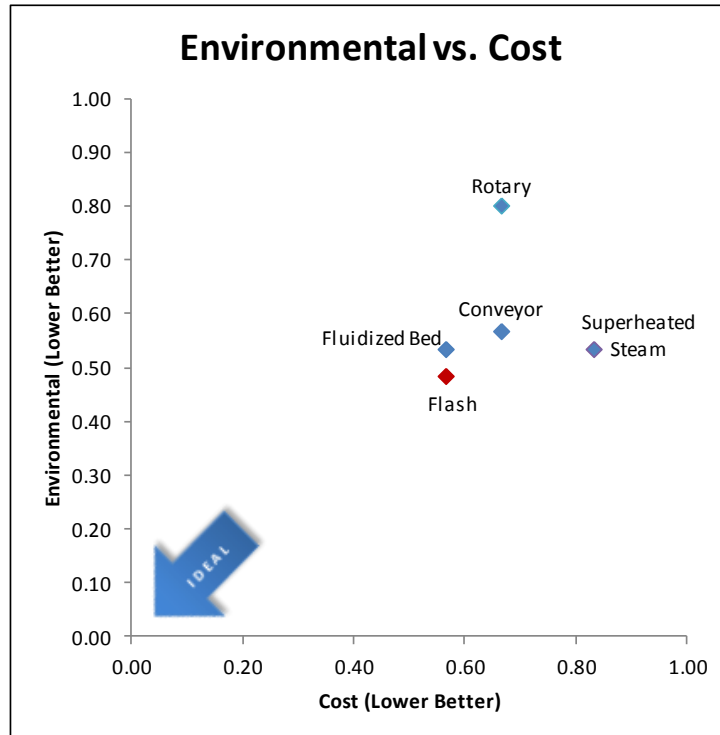

Figure 67. Dewater subsystem cost vs. environmental comparison.

*f. Recommendations*

Due to the limited development scope of this project, the AoA team chose to estimate the customer’s value scheme, rather than acquire specific customer input. Doing so would have required significant administrative burden that was not feasible for this study. Because of this limitation, the AoA team examined the sensitivity of the AoA model to different inputs. One excursion was created for each of the following goals, to minimize the facility, to minimize the power, and to minimize the environmental impact. These alterations are captured in Table 39 as light blue, light green, and dark green, respectively.

When these new stakeholder priorities were fed through the AoA analysis, however, the largest change in performance score was only 0.028 performance points. The closest any of the alternatives are to each other is 0.029 performance points. Based on these results, it was concluded that stakeholder re-prioritization of goals did not affect the end result of this AoA.

Additional sensitivity analysis was performed to capture the effects of modifying the system weights for cost, performance, and environmental impacts. These attributes were originally given equal significance to the system design, but the team varied these weights to uncover any resulting changes to the HNAABS design approach. An example of the modified ranking system is provided in Table 50.

	0.20	0.20	0.60	
	Cost	Env	Perf	3D distance
<b>Fluidized Bed</b>	0.57	0.53	0.70	0.42
<b>Conveyor</b>	0.67	0.57	0.56	0.52
<b>Flash Dryer</b>	0.57	0.48	0.81	0.36
<b>Superheated Steam</b>	0.83	0.53	0.65	0.52
<b>Rotary Dryer</b>	0.67	0.80	0.60	0.56

Table 50. Dewatering system sensitivity analysis showing 3-dimensional distance-to-ideal scores when performance represents 80% of the importance of the overall system.

In all cases, the flash dryer alternative remained the top choice for the final cultivation system based on a measurement of the 3-dimensional distance from the ideal solution. This is due to the fact that the flash drying option dominates all other alternatives across the three dimensions of cost, performance, and environmental risk. The fluidized bed dewatering process is a viable candidate when cost is weighted significantly higher than environment and performance, but flash drying still outperforms this alternative slightly based on better scores for performance and environmental risk. Consequently, flash drying appears to represent a robust dewatering design approach for inclusion in the final Cultivation System.

## **5. Extraction Subsystem Analysis of Alternatives**

### ***a. Scope and Background***

The final step in the algae cultivation system is to extract the green crude oil from the algae. This section covers the process of choosing one of the many extraction methods that are available and to flesh out the information needed to recommend a final cultivation system configuration. Although one of the outcomes of this AoA is the recommendation of an extraction method, the primary goal is to provide the reader with a systems engineering methodology that can be reapplied as new and additional information becomes available.

Prior to extraction, the useful oil remains locked within the cell walls of the individual algae cells. The primary goal of the extraction process is to extract this oil from within the cell walls. Because algae are plants, their cell walls are made of relatively tough cellulose materials. These cell walls must be ruptured in order to extract the oil; the process is also known as cell lysing. Algae cells are difficult to lyse because they grow individually, they are free-floating in their growth medium, and they are microscopic in size. These factors combine to make many methods that are applied to other types of plant oil extraction infeasible for algae oil extraction.

Although there are many existing methods designed specifically for algae oil extraction, most of these are low in technical maturity and are not ready for commercial scale implementation. Many current extraction methods suffer from factors

that reduce cost efficiency such as requiring dewatering and drying of the harvested algae while others have low oil extraction efficiency. Low extraction efficiency means a low percentage of the lipids are extracted and made available for further processing, while the rest either remains within cells that failed to rupture or is bound to the remaining biomass. For these reasons the cost of oil extraction is one of the barriers to commercialization of biofuels from algae. (Mercer 2011)

The oil extraction process is carried out some time after the algae have matured and are ready for removal from the growth containers. There may be one or more harvesting and dewatering stages required prior to the extraction process. The need for these steps depends on the input requirements of the extraction method chosen. Some oil extraction processes require relatively dry algae while others can process wet algae; the specifics of each of these input requirements are discussed in their descriptions in the following section. The particular harvesting and dewatering processes are analyzed separately in the previous sections.

Based on the results of this AoA, electroporation and chemical extraction are the two recommended oil extraction methods. Electroporation is the dominant choice, though because it has removed the need for dedicated harvesting and dewatering, chemical extraction was selected as the second choice to allow comparison between two different overarching cultivation systems. This allowed the HNAABS team to optimize total system performance by studying interactions between the various AoAs. The following sections describe the AoA process steps that were taken to reach this recommendation.

***b. Alternatives Investigated***

The extraction methods included in this AoA are only representative of the various methods available. There are many other methods that are not discussed primarily due to manpower and time constraints. There was an initial search to find as many methods as possible, but many were eliminated due to the lack of available data for quantitative comparison. Even for the methods that were used, assumptions were made to fill in missing quantitative data. The methods chosen for analysis were:

- Mechanical Expulsion using Expeller Presses
- Chemical Extraction using Dimethyl Ether
- Electroporation using Pulsed Electric Fields
- Atmospheric Decompression using Effervescence or Flash Boiling

Following are brief descriptions of the extraction methods used in this

AoA:

(1) **Expellers/Presses (Mechanical Expulsion).** According to B. Browne, mechanical expulsion using presses is a mechanical method that extracts oil from algae by physically squeezing or pressing it under high pressure. This ruptures the cell walls and results in the extraction of the oil. It is the simplest way to remove lipids from many types of feedstock, e.g. nuts, seeds, and grains. However, the typical feedstocks are macroscopic in size and the expeller presses are relatively simple low-tolerance machines when compared to what is needed to process microscopic algae cells. Because the algae cells are very small their associated extraction machines must be built with high tolerances making them costly to build and maintain. (Browne 2010)

As described in a paper by Lee and Shah and collaborated by the Oilgae website, the expeller press method requires extensive drying of the algae to as low as 10% water by weight of biomass prior to the extraction phase. Even when water has mostly been removed, to say 20% of biomass by weight, the biomass retains sufficient interstitial water to act as a lubricant within the press thus decreasing the effectiveness of extraction. Also, pressing only recovers approximately 70-75% of oil from algae. To reach this level of extraction efficiency, a solvent is typically used, commonly hexane, to remove the amount of oil remaining in the residual biomass after it is pressed. These yields may be too low for efficient scale up and not ideal for processing large volumes. A commercial expeller press using a screw device is shown in Figure 68 (Lee and Shah 2013) (Oilgae, Extraction of Algae Oil 2013).



Figure 68. Commercially available expeller press using a screw device; motor not shown. (From Hunan Double Elephants Machinery Company 2013).

This extraction method is assumed by to have a low requirement for water resources, but is high in electrical power requirements due to the use of an electric motor, which is required to drive the expeller press machinery. By itself, the expeller press appears to have very little impact to the environment, but the need for a chemical solvent to reach efficient extraction percentages may affect that assumption if implemented.

(2) **Chemical Extraction using Dimethyl Ether.** Chemical extraction using dimethyl ether (DME) is an experimental extraction method, which was chosen for analysis based on its potential of being a low-energy solution. In particular, the DME is able to both lyse the algae cells and dissolve the oil without extensive drying, although it does require a typical means of harvesting and dewatering to about 90% of water to algae ratio by weight. According to Praxair, Inc.'s Material Safety Data Sheet (MSDS) (Praxair, Inc. 2009), DME has a low boiling point of -24.8 degrees Celsius. As indicated in a report by the Central Research Institute of the Electric Power Industry (CRIEPI), this allows the DME to be distilled off with little or no heating required and results in a high quality oil product. The distilled DME can be condensed under pressure and reused; when configured as a continuous closed process, its throughput can theoretically be scaled up using parallel paths and with very little loss and subsequent replenishment requirement of the DME. Also, the cell lysing and oil extraction can be

performed at room temperatures at about 72 psi operating pressure, reducing the overall amount of energy to carry out the extraction process. Although it is considered by Praxair to be a hazardous material, due primarily to its flammability, it does not form harmful peroxides, it is considered non-toxic, and it is thought to have no harmful effects on global warming or ozone depletion, thus making it an environmentally friendly solvent; it is commonly used as an aerosol propellant. (Central Research Institute of the Electric Power Industry 2010) (Praxair, Inc. 2009). Figure 69 shows a lab experiment of extracting algae utilizing chemical extraction with dimethyl ether.



Figure 69. A column filled with algae/DME mixture (From Central Research Institute of the Electric Power Industry 2010).

In experiments performed by scientists at CRIEPI, extraction of oil from algae reached up to 40% by dry weight of the algae sample without previous drying, cell disruption, or heating of the algae. The actual water content of the algae sample was over 90%. The versatility of this method was evaluated by CRIEPI using a natural mixture of several species of blue–green microalgae, mostly of genus *Microcystus*. The extracted oil was characterized by high carbon/hydrogen content with a high calorific value of 33.8 MJ/kg, thus reflecting the high quality of the extracted oil. (Central Research Institute of the Electric Power Industry 2010)

(3) **Electroporation using Pulsed Electric Fields.** As stated in a book section authored by Kanduser and Miklavci, the electroporation method of cell lysing has been used in biological research laboratories for many years. In fact, it had made many of the early advances in genetic modification possible by allowing scientists

to pass genes into and out of living cells in a very controlled manner. In genetic research, the target cells are exposed to a carefully controlled electric field and the cell's membrane can be opened temporarily to allow the genetic materials to pass into or out of the cell. When the voltage is removed, the cell's membrane closes without killing the cell (Kanduser and Miklavcic 2009).

According to U.S. patent number 2012/00210481 assigned to the University of Texas, the method described above was primarily used on animal cells, but the same technique can be used to permanently lyse plant cells in a very similar process called irreversible electroporation (or simply called electroporation from here on), where the electrical energy is raised to a high enough level to permanently lyse the tougher algae cell walls. To enhance the lysing effect, the voltage is applied in pulses which further stress the cell walls until they rupture. The voltage amplitude, frequency, and duty cycle (the percentage of the time of each pulsed cycle that the voltage is “on” versus “off”) are adjusted to maximize the efficiency of the cell lysing process; this reduces the effects of differences in algal species and algal concentrations of the feedstock. (Hebner, et al. 2012)

More than one source notes that the favorable qualities of this method include little or no dewatering or drying of the harvested algae, little or no preheating of the algae mixture, and the use of natural gravity to separate the oil, water, and biomass after the extraction process. In addition, there are no harsh chemicals used and the water can easily be recycled back to the growth chambers without losing valuable nutrients. (Oilgae, Extraction of Algae Oil 2013) (OriginOil, Inc. 2013)

This method has also been developed into working system designs by more than one commercial vendor. For example, OriginOil™ has patents for, and has built, a complete electroporation system which they call Quantum Fracturing™. This system combines the electroporation method with enhancements, such as Ph modification using small quantities of injected CO<sub>2</sub>, and a specially designed electroporation chamber that aids in cell lysing using cavitation. The system used in the related AoA is mostly based on the system marketed by OriginOil™. Figure 70 illustrates the concept of a

complete electroporation oil extraction system, also called Single-step Extraction™, which uses OriginOil™'s patented method. (Eckelberry, Green and Fraser 2011)

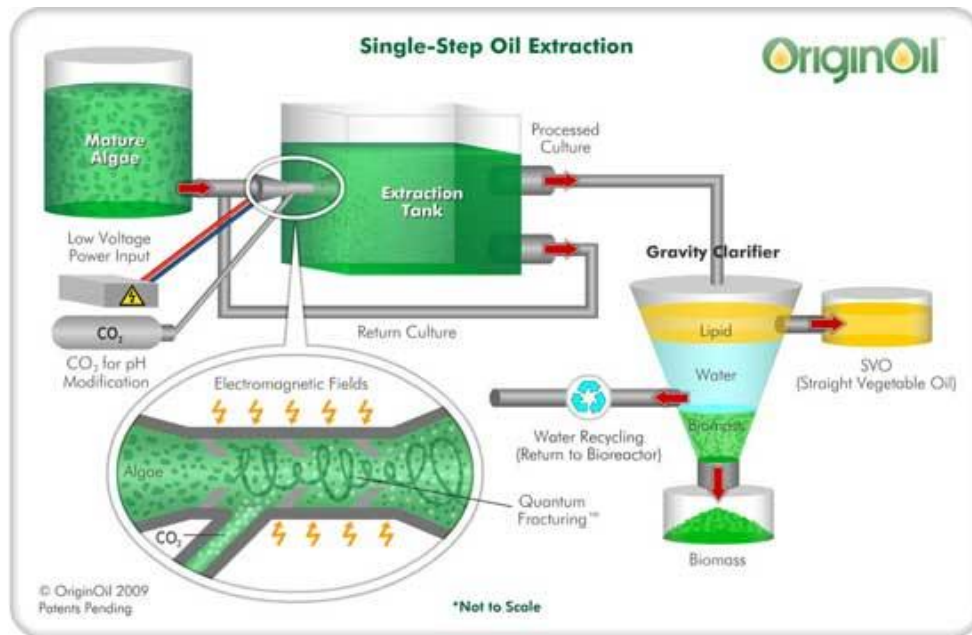

Figure 70. A concept illustration of the Single-step Oil Extraction™ method patented by OriginOil™; The inset shows a cutaway view of the Quantum Fracturing™ extraction chamber (From OriginOil, Inc. 2013).

(4) **Atmospheric Decompression using Effervescence or Flash Boiling.** There are two similar but distinctly differing methods of atmospheric decompression lysing. Both methods bring the algae into a particular state under pressure, but when the pressure is released expansion forces are created within the algae cells which cause them to rupture.

The first of these two to be discussed is called cell disruption and uses effervescence as its primary mechanism. As promoted by Parr Instrument Company on its company website, the method involves exposing the harvested algae to a non-reactive gas (typically nitrogen or CO<sub>2</sub>) using percolation in a closed chamber and under pressure. The gas will dissolve into the algae cells and become concentrated due to the high pressure. The pressure is then rapidly released and the gas will quickly effervesce, or fizzle, similar to the opening of a shaken can of carbonated beverage. Since the gas has

also dissolved into the algae cells, the rapid expansion of the gas will build pressure within the cell walls and cause the algae cells to rupture. Its use for algae cell lysing would require some dewatering of the harvested algae, energy to create the high pressure environment (typically over 2,500 psi), and a continuous supply of the inert gas. All of these factors contribute to a high process cost. At large production volumes, this process would also require expensive equipment to accommodate the containment of the high pressures and provide large surface areas required to promote rapid dissolving of the inert gas into the algae cells. (Parr Instrument Company 2013)

As discussed in a Defense Advanced Research Projects Agency (DARPA) report authored by the Science Applications International Corporation (SAIC), the other method involves heating the biomass above the normal boiling point of water within a closed container (allowing it to build pressure without boiling) and then quickly releasing the resulting pressure so that the super-heated water within the algae cells flash boils and ruptures the cell walls. Although seemingly much simpler than the first, this method requires more drying of the algae than the previous method (assumed to be so that energy is not wasted flash boiling the excess water rather than the algae cells). Also, the team considered the likeliness that the high temperatures require high amounts of energy input and supposes that it can also denature (or cook) the residual biomass rendering it less useful as a by-product. Favorably, no additional input requirements (such as the nitrogen or CO<sub>2</sub>) are mentioned, a disadvantage of the previous method. This second method was down selected by the Extraction Team prior to the actual AoA (Science Applications International Corporation 2010).



Figure 71. Examples of atmospheric decomposition chambers used in a recent study

(From Science Applications International Corporation 2010).

*c. Scoring*

(1) **Requirements Prioritization.** The first step in the scoring procedure was to identify the major stakeholders and determine the priority of their concerns. The research expedition to Hawaii was very helpful in gaining insight regarding the various effects of the HNAABS design on the Hawaiian environment, economy, and residents. By gathering the information that was obtained on the expedition, and making assumptions where needed, a list of important factors was agreed upon by the extraction Team. These factors are shown in Table 51 along with the scores assigned by the team. The scores were based on the following attributes:

- **Maximize Algal Oil Yield.** This is assumed to be the primary concern of the consumers of the biofuel end products because the total yield of algal oil is paramount to meeting the needs of those consumers and thus the feasibility of the entire project. This places importance on an extraction system that can scale to the production volume required by HNAABS. Scoring towards the left leads to a higher volume of algal oil yield.
- **Minimize Use of Manpower.** Manpower can be one of the most expensive cost line items in any business. It is important to keep manpower at a minimum, but it must be weighed against the possibility of lower production levels. Scoring towards the right favors keeping manpower costs low at the expense of unavailability of personnel required to reach maximum algal oil yield.
- **Minimize Power Input.** Not only is power input a major cost factor in producing biofuel economically, there is also the fact that electrical energy among the Hawaiian Islands is a very limited resource and building more power plants may not be the easiest answer. Scoring towards the right places more importance on keeping overall power input requirements low at the risk of not being able to produce the required amount of algal oil.
- **Minimize Transportation Accessibility.** The access to transportation includes availability of the highways, railways, and waterways to transport materials between and among the various HNAABS components. Scoring towards the right favors reducing

the amount of transportation traffic at the risk of reducing overall volume of algal oil production.

- **Minimize Unusable Waste Generation.** The generation of unusable wastes relates directly to the environmental impact of HNAABS on the Hawaiian Islands. The type and volume of these waste products are compared with the importance of reaching the required algal oil output. Scoring towards the right favors reducing the volume of waste products generated at the expense of total algal oil output.
- **Reduce Access to Resources.** The access to required resources is an important factor in choosing an extraction method. Some methods require the availability of hazardous chemicals, which may be difficult to obtain the required permits, while other methods may require a large amount of resources that are not affordable to obtain in sufficient quantities in Hawaii, including land and fresh water. Scoring to the right places more importance on the restrictions that cause limited resource availability and thus less importance on algal oil output.
- **Maximize Sellable By-product Output.** The availability of sellable by-products may influence what method is chosen. Some methods can destroy the post-extraction biomass rendering it useless, while others can maximize the useable by-products. Scoring to the right will place more importance on resellable by-products at the expense of total algal oil output.

Factor	Combined Score									Factor
Maximize Algae Oil Yield	9	7	5	3	1	3	5	7	9	Minimize Use of Manpower
	9	7	5	3	1	3	5	7	9	Minimize Power Input
	9	7	5	3	1	3	5	7	9	Minimize Transportation Usage
	9	7	5	3	1	3	5	7	9	Minimize Waste Generation
	9	7	5	3	1	3	5	7	9	Minimize Use of Resources
	9	7	5	3	1	3	5	7	9	Maximize Sellable By-products

Table 51. Requirements prioritization - these are the extraction process scores (highlighted green) obtained by averaging the scores from each team member.

To obtain the final scores, each stakeholder scored the importance of each factor when compared to the primary factor; namely to the Maximize Algae Oil Yield factor. For the sake of averaging, the numbers on the left were treated as positive

and the numbers on the right were treated as negative, and then each row was averaged and the resulting score entered as shown. Keep in mind that not all of the stakeholder's concerns could be known or considered in this analysis and, because the IPT members are not the actual stakeholders, the outcome is not to be considered a final input for any actual or formally proposed HNAABS configuration. Rescoring using new information obtained from the actual stakeholders could possibly change the overall recommendation of the extraction method.

(2) **Pairwise Requirements Comparison.** Similiar to the other AoAs performed, a pairwise comparison matrix was developed to compare each priority to each other. The matrix is shown in Table 52.

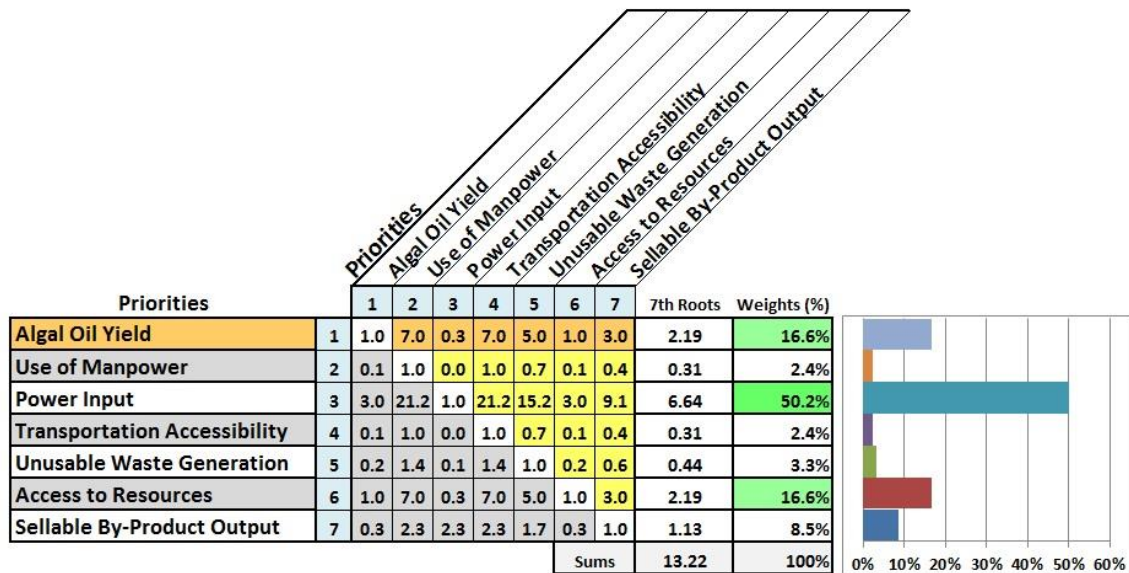

Table 52. Extraction subsystem pairwise comparison matrix - the highest eights are highlighted green and indicated by the longer graph bars.

As illustrated, Power Input, Algal Oil Yield, and Access to Resources are among the most important performance criteria for this subsystem. Of particular notability is that the Power Input factor is deemed to be more important than the Algal Oil Yield. This can be interpreted as there being a hard limit constraint on how much power the extraction process should be allowed to consume even at the sacrifice of not being able to reach the required amount of algal oil yield. Each of these weights was

used in the HoQ matrices in determining the optimal alternative for the oil extraction subsystem portion of the growth system.

(3) **Requirements to Design Characteristics Allocation.** The Team compiled a list of design characteristics of a conceptual extraction subsystem, which focused primarily on the high-level technical design requirements of the subsystem. At this first level of subsystem design, the characteristics mostly represent the inputs, controls, outputs, and mechanisms (ICOMs) that must interface with the adjoining systems, although they are not completely restricted to these types of items. A list with an explanation of each follows:

- **Biomass Species Requirements.** Some extraction methods might require a specific species of algae, while others can accept a variety of species. The methods that can accept a wider variety of algae species should be considered more favorable than those methods that are restricted to fewer species.
- **Biomass Input Water Content.** Some extraction methods require a specific harvesting or dewatering/drying method, while others may be able to process the wet algae with little or no water removal. The drier algae requirements usually mean a higher cost for the input algae product.
- **Extraction Efficiency.** Extraction methods vary in the amount of algae oil they can extract out of the total oil available in the algae. This is usually expressed as a percentage. The better the extraction efficiency the more oil will be made available as algal oil yield, but it may be at the cost of additional power, water, or other resources.
- **Process Energy Usage.** The amount of energy necessary to perform the extraction process can depend on the source of the energy. Although it is commonly electrical power, it could be in some other form of energy unique to a particular extraction process. Electricity is expensive in Hawaii so considering other forms of energy could be an advantage and may affect the choice of the extraction process.
- **Process Water Usage.** Like electricity, water is a constrained resource in Hawaii, at least when referring to fresh water. Oahu has very little available fresh water while all islands naturally have access to plenty of saltwater from the ocean. Some extraction methods can be large consumers of fresh water, while a method that can operate with saltwater might be more preferable, but should be minimized if possible.

- Post-extraction Purification. The purity of the oil output is important to the processors that must refine it into biofuel. This characteristic focuses on the ability of the extraction system to produce a high tolerance on the amount of desirable oil substances verses substances that reduce the ability to refine the oil.
- Post-extraction Processing. Although it seems similar to the previous design characteristic, this one has emphases on most other processing that does not affect the purity or quality of the oil. These could be processing of wastewater, disposal of hazardous chemicals, and preparation of biomass by-products for sale. The extraction methods will have varying degrees of pros and cons in each of these areas.
- Post-extraction Water Recycling. The amount of water that can be recycled within the process for fed back into a previous stage would be favored over any process that spoils the water and renders it unusable.
- Post-extraction Waste. The process that produces less waste will be favorable to one that produces more waste. Some waste products cannot be processed for reintroduction into nature and the Team can expect those to be an unfavorable method.
- Post-extraction Usable By-products. If an extraction process can produce sellable by-products along with a high oil yield, then that method would be favored. Some methods spoil the remaining biomass resulting in waste rather than additional revenues.
- Infrastructure Requirements. Infrastructure includes buildings, roads, pipelines, drainage, power lines, and employee housing. Although these could have more to do with choosing a location, if the extraction method chosen has many high requirements for these and similar characteristics, then the choice of available land might be more costly. Low requirements are generally better.
- Transportation Requirements. Similar to the previous characteristic, the transportation requirements may necessitate a particular location that could be more costly to acquire. Low requirements are generally better.
- Personnel Requirements. All aspects of personnel requirements should be considered including availability of expertise, cost to train employees, and employee safety. Lower requirements are generally better.
- Land Surface Requirements. The type of land where an extraction facility is located ties to the previous characteristics that may restrict the location. This one deals strictly with the cost of the land

to obtain and develop into what is needed by the particular extraction method. Lower requirements are generally better.

- **Process Reliability.** Although this characteristic includes the reliability, availability, and maintainability (RAM) of the equipment and facilities, it also includes the repeatability of the process itself. Any consideration of technical readiness level (TRL) is included here. Higher reliability is favorable.

These characteristics are then scored by their degree of influence on the concerns of the stakeholders. The IPT team met and arrived at a consensus of scores as shown in Table 53. These scores were then adjusted using the weights from the previous Extraction Subsystem Pairwise Comparison Matrix. Final weighting was calculated using a dot product calculation between each column of scores and the column of previously determined weights. A scoring scale using 1, 3 and 9 was used; a design characteristic given a scoring of 1 would indicate less importance while 9 would indicate the highest importance, and no score means there is no interaction. All of the scores were then normalized to calculate a percentage of weighted importance of each characteristic.

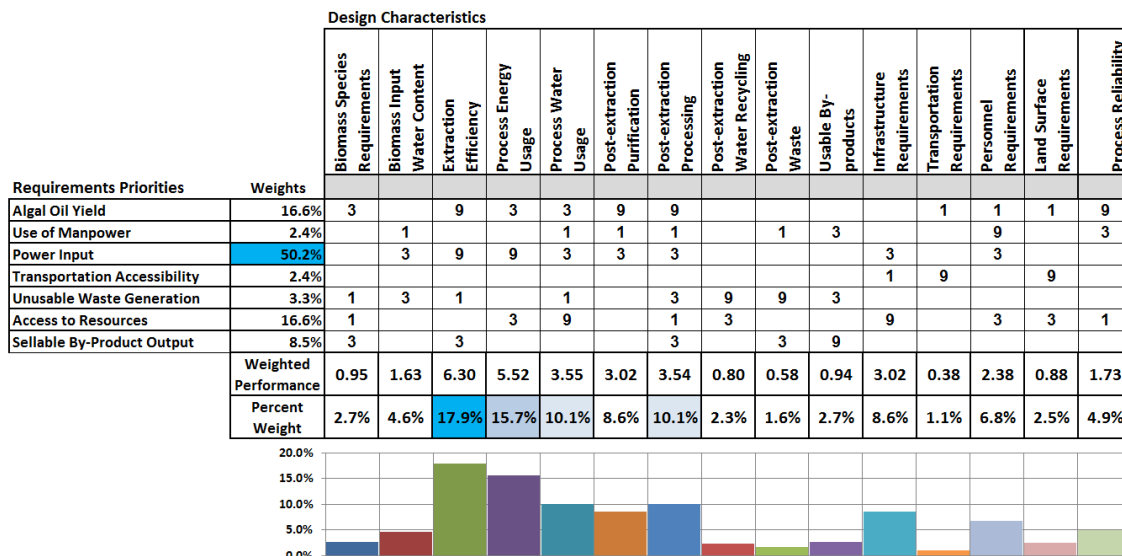

Table 53. Extraction subsystem requirements to design allocation - the best scores are highlighted in blue.

The six highest scoring design characteristics are, in order from highest to lowest, extraction efficiency, process energy usage, process water usage, post-extraction processing, post-extraction purification, and infrastructure requirements. These results were then carried forward to the next phase of the analysis to determine the performance weighting for the subsystem functions.

(4) **Design Characteristics to Functions Allocation.** Next, the extraction IPT compiled a list of subsystem functions of a conceptual extraction subsystem, which focused primarily on the high-level functional properties of the subsystem. At this level of subsystem design, the functions represent the processes that are performed in order to produce the algae oil. A list with an explanation of each function follows:

- Preprocess Algae Input. This is the primary interface from the growth, harvest, and dewater/drying processes. Any additional preprocessing is performed in this function.
- Regulate In-process Additives. This function controls any chemicals, e.g. solvents or gasses that are added to the input stream prior to the extraction function.
- Control Extraction Environment. This includes regulating temperature, Ph, salinity among other environmental parameters.

- Monitor Extraction Environment. This monitors the above parameters along with extraction efficiency in order to provide feedback signals required by the control system.
- Extract Algae Oil. This is the primary function of the extraction subsystem, which is to carry out the extraction of the oil from the algae.
- Output By-products. The residual biomass materials following the extraction process must have its own process to remove it from the subsystem.
- Process and Dispose of Waste. Any processing of waste material must be performed before its transportation and disposal.
- Recycle Materials. This function includes preparing the recyclable water and making it available for reuse. It may also include chemicals and gasses that can be reused.
- Maintain Extraction System. This is the function that performs the RAM processes.

These subsystem functions can be seen listed along the top of the Design Characteristics to Functions Matrix shown in Table 54. The IPT has placed their consensus interaction scoring and the calculations have been performed identically to the previous analysis matrix.

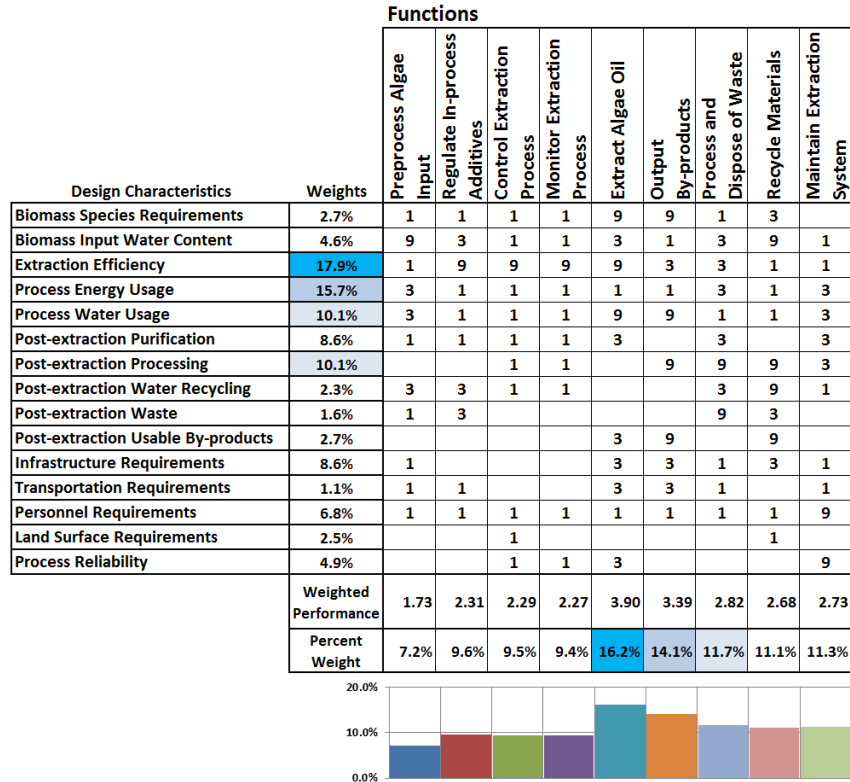

Table 54. Design characteristics to functions matrix - highest scoring functions are highlighted in blue.

Not surprisingly, the results of this part of the analysis show the Extract Algae Oil and Output By-products as the more important functions in the subsystem, although all functions fare well amongst each other in the overall analysis.

(5) **Functions to Form Allocation.** The extraction IPT compiled a list of abstract physical forms of a conceptual extraction subsystem. Although still very early in the design process, it is important to have a high-level conceptual physical design that can then be matched with the available physical alternative system designs. These abstract forms will represent general types of physical components that can perform the functions identified earlier. The nature of most of this equipment involves tanks, filters, valves, motors, pumps, gauges, etc. The list of physical form is as follows:

- Input Transport Equipment. This will typically include tanks, pipes, and valves if co-located with the other cultivation

subsystems, but could also include trucks, railcars, or barges if not co-located.

- Preprocessing Equipment. Includes vessels, injectors, gauges, pressurizers, bottles, motors, pumps, and required electronics.
- Extraction Equipment. This includes chambers, tanks, energy emitters, heaters, coolers, pressurizers, grinders, or other specialized extraction equipment. This could be commercial off-the-shelf (COTS) equipment, custom built equipment, or both, to handle the volume of oil extraction required.
- Separator Equipment. This includes tanks, bypasses, evaporators, condensers, filters, etc. Provides for input of algae oil/biomass/water mixture (after extraction process has been performed) along with outputs for separated oil, water, biomass by-products and other materials.
- Oil Purifier Equipment. Provides additional processing of output oil stream if required.
- Output Oil Transport Equipment. Includes holding tanks, pumps, pipes, valves, etc. Also, could include long distance pipelines, trucks, railcars, or barges.
- Output By-products Equipment. Equipment to prepare and package the algae biomass for sale as a useful by-product. This could include dewatering and drying equipment similar to those analyzed in separate AoAs, depending on the requirements for the final output of the by-products.
- Waste Processing Equipment. Treating and transportation equipment for wastewater, chemicals, waste oil from maintenance procedures, etc.
- Maintenance Equipment. Includes tools, spare parts, lubricating oils, etc.
- Infrastructure Equipment. Includes land, buildings, office equipment, general utility services (including potable water), and commercial electricity service.

These physical forms are placed in the top row of the Functions to Form Matrix shown in Table 55. The IPT has placed their consensus interaction scoring and the calculations have been performed identically to the previous analysis matrices.

Functions	Weights	Form									
		Input Transport Equipment	Preprocessing Equipment	Extraction Equipment	Separator Equipment	Oil Purifier Equipment	Output Oil Transport Equipment	Output By-products Equipment	Waste Processing Equipment	Maintenance Equipment	Infrastructure Equipment
Preprocess Algae Input	7.2%	3	9	3							3
Regulate In-process Additives	9.6%	3	9	3	1	1			3		1
Control Extraction Process	9.5%	1	1	9	3	3		1	1		1
Monitor Extraction Process	9.4%	1	1	9	3	3		1	1		1
Extract Algae Oil	16.2%		3	9	3	3	9	3	1		3
Output By-products	14.1%			3	9			9			1
Process and Dispose of Waste	11.7%				3			1	9		3
Recycle Materials	11.1%			3	9	1		1			
Maintain Extraction System	11.3%			1						9	1
Weighted Performance		0.69	2.18	4.53	3.77	1.26	1.45	2.17	1.69	1.02	1.59
Percent Weight		3%	11%	22%	19%	6%	7%	11%	8%	5%	8%

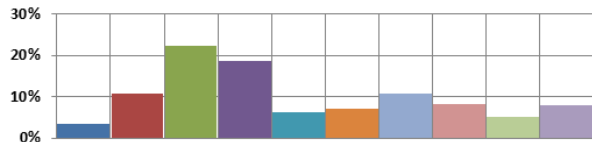

Table 55. Functions to form matrix - of the physical attributes of the conceptual oil extraction system, the most important are highlighted in blue.

Unsurprisingly, the results of this analysis show that of all the equipment required to perform the extraction process, the Extraction Equipment and Separator Equipment are the most important. This may be obvious, but the important outcome is that it has provided a prioritization of the other physical attributes of the subsystem.

(6) **Forms to Extraction Method Performance Allocation.**

This matrix uses the percent weight of each conceptual physical form attribute and compares them to the attributes of the real alternative extraction methods being analyzed in this AoA. Similar to the previous matrices, the Team placed the importance weights into the matrix, but this time they remained in the top row; this is simply for the sake of cosmetic formatting and appearance, the outcome would be the same if they were placed in the left column like before.

As a reminder, the following four extraction methods were analyzed:

- Mechanical Expulsion using Expeller Presses
- Chemical Extraction using Dimethyl Ether
- Electroporation using Pulsed Electric Fields
- Atmospheric Decompression using Effervescence

Scoring was performed similarly to the previous matrices using as much real data as possible to make quantitative comparisons between the physical attributes of each of the alternative methods. Unfortunately, not all of the data was available for analysis, in which case assumptions were made where needed. The data and rationale for each assumption are included in the following discussion.

		Forms											
Alternatives	Weights	Input Transport Equipment	Preprocessing Equipment	Extraction Equipment	Separator Equipment	Oil Purifier Equipment	Output Oil Transport Equipment	Output By-products Equipment	Waste Processing Equipment	Maintenance Equipment	Infrastructure Equipment	Weighted Performance Total	Normalized Score
Mechanical Expulsion		2	2	1	1	2	2	3	1	1	1	16.00	0.21
Chemical Extraction		2	2	3	1	2	2	3	1	3	2	21.00	0.27
Electroporation		3	2	3	3	3	2	2	3	2	2	25.00	0.32
Atmospheric Decompression		1	1	1	2	2	2	3	2	1	1	16.00	0.21

Table 56. Extraction subsystem performance AoA results - the highest scores (highlighted in green) are indicative of the best performing extraction alternative among those that were analyzed.

The final result from this performance analysis indicates that electroporation is the better performing extraction method with chemical extraction as a close second place performer. The choice of each ranking score is as follows:

- Input Transport Equipment. This equipment would perform batching of the algae if required by the extraction process. Electroporation requires no batching and therefore no batching equipment, so scored the best, while atmospheric decompression

does require batching. The other two methods depend on their implementation so was scored more moderately than the other two.

- Preprocessing Equipment. All methods scored moderately, except for the atmospheric decompression which requires the algae to be pressurized and gas treated.
- Extraction Equipment. The most important factor is the extraction efficiency of the method. Electroporation and chemical extraction scored highest with an estimated 95 to 97 percent, and 70 to 75 percent efficiency, respectively. The other two scored poorly with 40 percent or below for each.
- Separator Equipment. Electroporation scored highest because it uses a simple gravity clarifier to separate the extracted components. Chemical extraction requires a process to recycle the chemicals, thus a low score was applied. Mechanical expulsion would require a chemical separation process to attain sufficient extraction efficiency levels which is why it also scored low. The separation process for atmospheric decompression is unknown, but it was assumed it is similar to mechanical expulsion and requires a chemical to maximize efficiency so scored poorly.
- Oil Purifier Equipment. Electroporation requires little to no oil purification after the gravity clarifier, so scored very well. The others scored moderately, mostly due to lack of information about their performance.
- Output Oil Transport Equipment. All methods scored moderately. There was no reason to believe that any method required different handling of the output oil than the others.
- Output By-products Equipment. Mechanical expulsion and chemical extraction scored high only for the reason that the algae biomass is assumed to be a lower-valued by-product due to the use of chemicals and therefore requires less equipment to process the by-products. Electroporation scored moderately because the biomass needs at least dewatering, if not complete drying. The atmospheric decompression scored high because the by-products are useful with less equipment required to process it.
- Waste Processing Equipment. Chemical extraction and mechanical expulsion scored low due to the handling of waste chemicals. Electroporation scored highest due to the ability to recycle most of the water used in the system.
- Maintenance Equipment. Mechanical expulsion and atmospheric decompression scored low due to the amount of machinery expected to be used in the system, and thus requiring maintenance.

Chemical extraction has the least amount of machinery and scored the best.

- Infrastructure Equipment. Mechanical expulsion and atmospheric decompression both have high electrical energy demands and so have a high reliance on electrical infrastructure. The others scored moderately as there was no specific high need item identified.

(7) **Cost and Environmental Comparison Ranking.** To

determine a preferred oil extraction alternative, the team assessed the cost of operations of each method and their environmental impact. The cost drivers included in this comparison were:

- Operating costs. This includes all operating costs, such as electricity, water, chemicals, filters, replacement parts, lubricants, etc. Manpower is considered separately.
- Manpower. Includes only manpower estimates relating directly to the extraction process. Administrative manpower should be analyzed elsewhere.
- Capital (Equipment). Cost of equipment required to perform the extraction entire process
- Capital (Facilities). Cost of facilities, such as buildings to house the equipment.

The results of the cost vs. environmental comparison are shown in

Table 57.

Parameters and Impacts	Weight	Mechanical Expulsion	Chemical Extraction	Electroporation	Atmospheric Decompression
Operating Costs	40%	3	2	1	2
Manpower Costs	30%	3	1	2	2
Capital (Equipment)	15%	2	2	2	3
Capital (Facilities)	15%	2	3	1	3
Cost Score		2.7	1.85	1.45	2.3
Normaized Cost Score		0.33	0.22	0.17	0.28

Table 57. Extraction subsystem cost weighting - the best scores (lower is better) are highlighted in green.

The environmental impact factors of concern are:

- Land usage. The amount, type, and location of land each process utilizes is considered. The more restrictive the land requirement, then the less favorable score (higher) is used.
- Water consumption. The amount of water that is consumed during the extraction process. This does not include water that is recycled back to the growth chambers. If the method can use saltwater, then it is assumed that it will do so.
- Water waste. The amount of unrecoverable water that is tainted and considered hazardous, and thus requires a treatment process to either recycle it back to the growth chambers, or release it back into the environment.
- Energy. The total use of energy resources to carry out the extraction process. This would include electrical power taken from the power grid and any power that is generated onsite from petroleum sources. Solar, wind, and burning of biomass to self-generate electricity are considered environmentally friendly.
- Ecosystem. The impact to the entire Hawaiian ecosystem is considered. Use of hazardous chemicals in the process may add risk to the ecosystem.
- Air. The impact to the air quality of Hawaii is considered. Although air quality is not much of a problem in Hawaii due to its prevalent winds and being surrounded by open ocean, it remains a concern of the stakeholders.

The results of the environmental comparison are shown in Table 47.

Parameters and Impacts	Weight	Mechanical Expulsion	Chemical Extraction	Electroporation	Atmospheric Decompression
Land Usage	40%	2	2	2	2
Water Consumption	15%	3	3	1	2
Water Waste	15%	3	3	1	1
Energy	15%	3	1	1	2
Ecosystem	10%	3	3	1	2
Air	5%	2	2	2	2
Environmental Score		2.55	2.25	1.45	1.85
Normalized Environmental Score		0.31	0.28	0.18	0.23

Table 58. Extraction subsystem environmental weighting - the best scores are highlighted bright green.

(8) **Results.** The resulting performance, cost, and environmental scores for each method were then plotted on graphs; cost vs. performance, environmental vs. performance, and cost vs. environmental are shown as Figures 72, 73, and 74, respectively. The favored choices of the extraction methods have been circled in red.

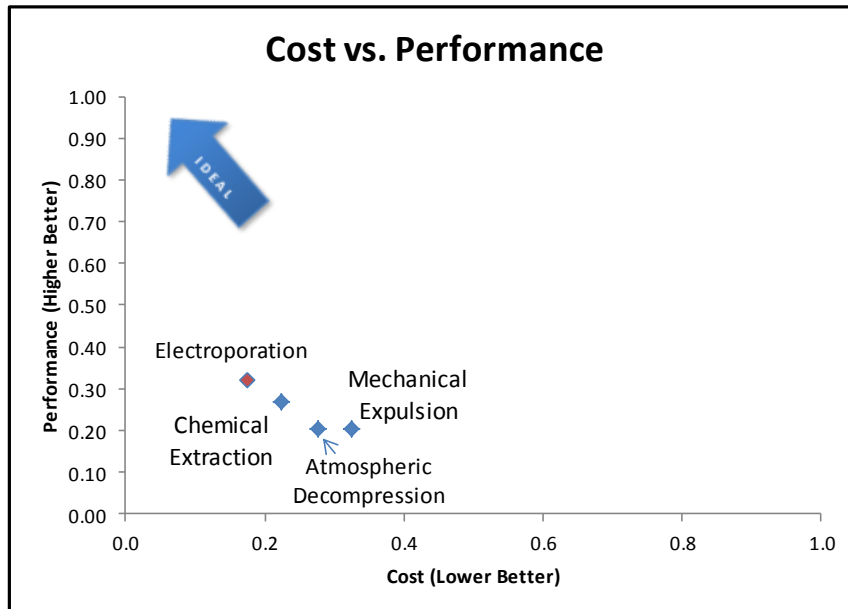

Figure 72. Cost vs. Performance Chart – The extraction methods within the trade-space are shown in red.

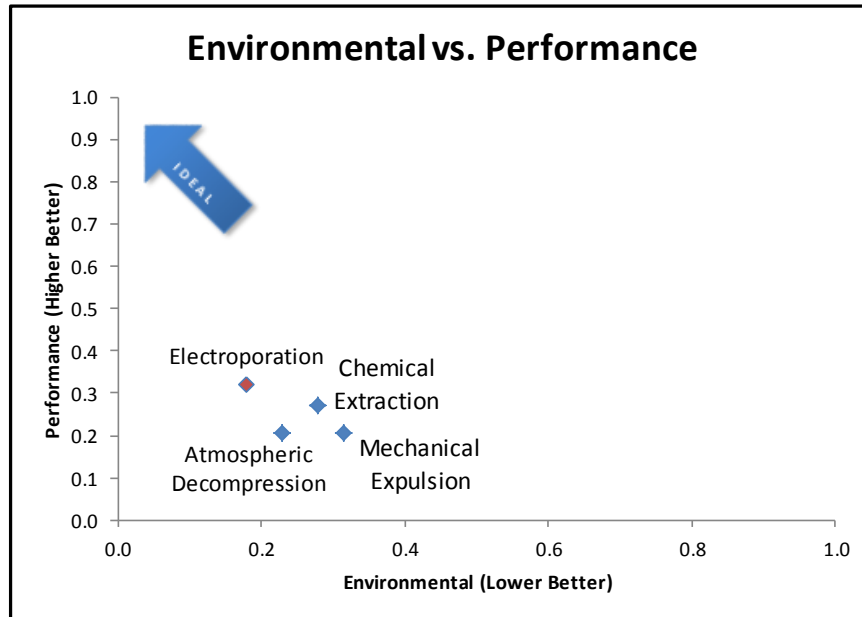

Figure 73. Environmental vs. performance chart – the extraction methods on the efficient frontier are shown in red.

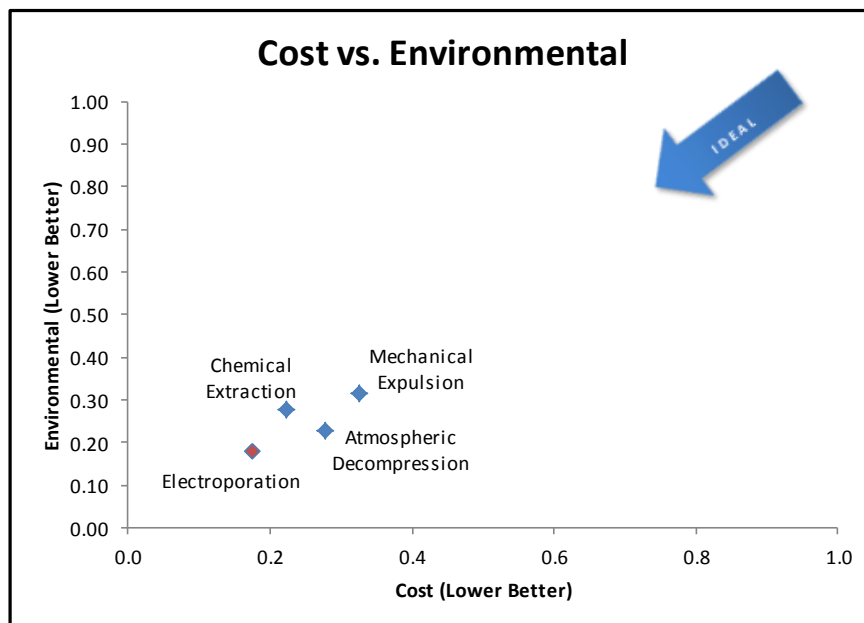

Figure 74. Cost vs. environmental chart – the extraction methods on the efficient frontier are shown in red.

Table 59 shows the numerical values of each extraction subsystem scores for cost, performance, and environmental. For both cost and performance, electroporation is the highest scorer for both cost and performance.

	Results (Normalized)		
	Cost (Lower Better)	Performance (Higher Better)	Environmental (Higher Better)
<b>Mechanical Expulsion</b>	0.33	0.21	0.31
<b>Chemical Extraction</b>	0.22	0.27	0.28
<b>Electroporation</b>	0.17	0.32	0.18
<b>Atmospheric Decompression</b>	0.28	0.21	0.23

Table 59. Results comparison for cost, performance, and environmental for the extraction subsystem analysis of alternatives. The top subsystems for each factor are highlighted in green.

*d. Recommendations*

After the investigation of several means of extracting oil from algae, the team found that both electroporation and chemical extraction scored sufficiently above the other alternatives being considered for both to proceed into the final configuration analysis. These two methods have markedly different input requirements and the final configuration involving the growth, harvest, and dewatering methods was not a part of this specific analysis. By recommending that both proceed more options were available in the final configuration analysis, with the caveat that any steps between growing and extraction would add directly to the cost of production.

There is substantial information available regarding the specific electroporation implementation patented by OriginOil™ called Quantum Fracturing™; this information is included here in support of the IPT’s recommendation. Although not all inclusive, it does provide a look into the underlying technology and a current snapshot of the state of progress toward commercial viability.

Like the other three subsystems, sensitivity analysis was used to understand how variations in attribute weighting affected the final extraction method recommendation. Similar to the dewatering system, one alternative dominated all three attributes. Because electroporation scored best across the three cost, environmental, and performance factors, the sensitivity analysis showed minimal effect on the overall system results. Table 60 shows one example of the sensitivity analysis process in which cost was weighted at two times the importance of the other two factors.

	0.50	0.25	0.25	
	Cost	Env	Perf	3D distance
<b>Mechanical Expulsion</b>	0.33	0.31	0.21	0.48
<b>Chemical Extraction</b>	0.22	0.28	0.27	0.42
<b>Electroporation</b>	0.17	0.18	0.32	0.37
<b>Atmospheric Decompression</b>	0.28	0.23	0.21	0.46

Table 60. Oil extraction system sensitivity analysis showing 3-dimensional distance-to-ideal scores when cost represents 50% of the importance of the overall system.

In all cases, the electroporation alternative was the best option for the final cultivation system based on a measurement of the 3-dimensional distance from the ideal solution. Based on the results of the subsystem analysis of alternatives and sensitivity analysis, electroporation appears to be a robust solution for the final cultivation design. However, because the chemical extraction score was relatively close to electroporation three-dimensional distance to ideal, both configurations were carried through for further analysis in Section V of this paper. The Team selected Quantum Fracturing™ and chemical DME as the potential extraction methods to combine with the results of the other AoAs into a final Cultivation System design.

(1) **Quantum Fracturing™, Electroporation, and**

**Irreversible Electroporation.** Quantum Fracturing™ is a trademark of OriginOil, Inc. of Los Angeles, CA, USA (OriginOil, Inc. 2013). It appears to be a variation of a process called "electroporation", the etymology being "electro-" referring to its use of an electric field and "-poration" referring to the creation of pores, or holes, in the target cell walls. A further variation of the term is "irreversible electroporation" where the cell walls of the

target cells are permanently and irreversibly disrupted causing lysing of the cells. In this analysis of the oil extraction process chosen by HNAABS, electroporation and irreversible electroporation are used interchangeably and refer to the chosen oil extraction process in general. The term Quantum Fracturing™ refers specifically to the OriginOil patented and trademarked process, when appropriate. The following discussion relies heavily on information that was collected mostly from biofuel technology media articles, the patent which protects the process implementations, the company's public website, and also public video postings of interviews with company personnel.

When considering the recommendation of Quantum Fracturing™ as the preferred oil extraction method, i.e. during the oil extraction analysis of alternatives, many of the details of its operation were unknown. It was known to be an emerging technology and proprietary in nature which were considered in the technology readiness level analysis and risk level assessments. The applicable U.S. Patent #20110095225 provides information about the details of the process. The reader should keep in mind that it was specifically identified by name as an oil extraction alternative early in the technology development phase primarily due to its prominence in the biofuel media and the level of promotional effort put forth by the trademark owning company, OriginOil, Inc. The previous and following discussions should not imply that the equipment supplier or the technology chosen should specifically bear the Quantum Fracturing™ name, except those restrictions required by the applicable patents.

Electroporation is a method of lysing living cells to extract the cells inner contents. It uses the ability of a series of electric pulses to create destructive forces on the cell walls. It works with many cell types, including algae cells. This is because most living cells have a different electrical time constant between the interior of the cell and the outside medium (Hebner, et al. 2012). When a pulsed electric field is passed through the medium with the algae cells in suspension, it induces unequal forces between the interior and exterior of the algae cells which are floating in the growth medium. This places destructive forces on the cells which elongates the cell walls and ultimately degrades and disintegrates them.

The simplest implementation for a continuous process system would be to place two planar electrodes, a cathode and an anode, parallel to each other and then sealing the arrangement on two sides with electrically insulating material to form a passage through which the algae mixture can flow. The correct size of the passage is important to allow sufficient flow without clogging, but not be so large that it requires excessive energy to maintain the electroporation effect.

Specifically in the Quantum Fracturing™ design, this arrangement is improved by placing two conducting tubes, one coaxial to the other, separated by a spirally wound electrical insulator. This maintains electrical isolation between the anode and the cathode while also forcing the algae flow to follow a spiraling path through the lysing chamber. (U.S. Patent 2011/0095225, OriginOil) The system can be scaled to larger flow rates by combining individual lysing chambers in parallel (U.S. Patent 2011/0095225, OriginOil) along with the appropriate additional electrical pulse capability.

This process can be applied to many different algae species in both fresh water and saltwater growth medium by varying several electrical parameters of the electroporation device, including the pulse frequency, pulse duty cycle, and the pulse amplitude. The pulse frequency is expressed in Hertz (Hz) where 1 Hz is equal to one pulse per second. The pulse duty cycle is a unit-less ratio of the "on" verses "off" time during a full cycle of the pulse, usually expressed as a percentage. The pulse amplitude is the peak electromotive force applied to the algae culture and is expressed in volts. Because of the difference in electrical properties of fresh water and saltwater, the nutrient content, and the various algae species, these electrical parameters must be adjustable in order to tune the system to optimize the extraction efficiency according to the present system state. Specifically, by varying the amplitude and duty cycle, the total energy that is applied to the algae culture can be adjusted to the level that successfully lyses the cells without using excess energy. The proper frequency is a function that can vary depending on the species of algae chosen among others factors. Other variables such as temperature, Ph, and nutrient levels of the growth medium can also affect the optimal electrical parameters. (Carlson, et al. 2010) (Foltz 2012). These variables can change substantially

as the algae stream passes through the electroporation device. This makes it important to implement an electronic control system that senses the actual voltage and current at the electroporation device in real-time and enable the ability for these parameters to be maintained from one pulse to the next. (U.S. Patent 8,222,909, Ragsdale)

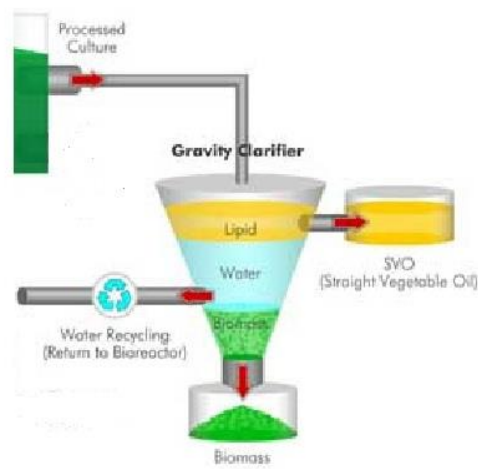

Figure 75. Gravity clarifier as illustrated for the Quantum Fracturing™ process by OriginOil.

It has been found by several independent researchers that the efficiency of the electroporation process can be improved by adding certain additional sub-processes, albeit typically at additional operational costs. For instance, Carbon dioxide (CO<sub>2</sub>) gas injected into the algae stream as it flows through the electroporation chamber helps to enhance the cell lysing rate possibly by modifying the Ph levels of the cells and growth medium and increasing the stresses on the cell walls when the electric field is applied. The addition of a cavitation inducing channel at a point after the CO<sub>2</sub> injection can also help to improve the oil extraction efficiency. In addition, preheating the algae mixture prior to it entering the electroporation chamber is thought to assist in the oil extraction process by weakening the cell walls. An additional benefit of heating is faster and more efficient operation of the gravity clarifier.

The redesigned electroporation device can accommodate the previous enhancements in addition to being able to attain a higher flow rate for each

device possibly allowing the ability for the system to scale to commercial production volumes. This appears to be the current design being implemented in the Quantum Fracturing™ technology promoted by OriginOil. (U.S. Patent 2011/0095225, OriginOil)

## (2) **Commercial Scaling Potential of the Quantum**

**Fracturing™ Technology.** Although the application of electroporation technology to the biofuel industry is a relatively new idea, OriginOil is currently making efforts to scale the related Quantum Fracturing™ technology to prove its commercial viability. As explained in several press releases and publically posted video interviews, they are teaming with MBD Energy of Australia to create a one-hectare (2.5 acre) PBR-based pilot project algae farm co-located with the Tarong Power Station, in Queensland, Australia. This power station is a 1400 million watt (MW) coal-fired power generation station that outputs massive amounts of CO<sub>2</sub> gasses from its exhaust flues. Co-locating the algae farm with the power plant provides access to the CO<sub>2</sub> gas after rerouting it to algae growth chambers and also as the injection gas for the Quantum Fracturing™ process. After the pilot program is proven to be commercially viable, plans include a second stage that would expand the project to almost 200 acres (Algae Industry Magazine 2013). The scale of a multi-staged project after the pilot concept stage is thought to be viable. (Algae Industry Magazine 2013)

According to press releases, OriginOil has already shipped its first complete commercial-grade algae oil extraction system to MBD Energy. Although the implication is that it is not of sufficient capacity for the entire output of even the pilot project's size, a firm order has been placed to produce a complete system capable of processing 300 gallons of algae culture per minute; large enough to handle the entire pilot program's planned output. In comparison, the HNAABS system will require 1221 OriginOil systems to extract the oil from the algae feedstock. The Team believes that improvements and throughput increases are likely, and will improve the performance of the algae cultivation system, however, current performance is still technically feasible.

## **6. Results and Recommendations**

Based on the results of the subsystem analysis of alternatives various configurations were analyzed and compared in detail in Section V of this paper. The Team selected Photobioreactors and Quantum Fracturing™ to be used in the primary system configuration. A secondary system configuration was developed to highlight the top level system comparison and optimization possible by evaluating the interactions between the AoA candidates, rather than focusing on each AoA individually. Most systems had a clear, dominate winner, so the selection of alternatives was very simplified. Growth did not have a clear an answer, as a different system was the best choice for each of the cost, environmental, or technical performance. Because land costs are a significant reoccurring cost for the HNAABS system, efficiency and land use were considered more strongly than other factors for considering which growth system was selected for use. This lead to the selection of the photobioreactor, and the efficiency and land reduction protection is greater than most other systems, while still having a better technical maturity than the OMEGA system.

The secondary system configuration consisted of photobioreactors for growth, microfiltration for harvesting, flash drying for dewatering, and DME chemical treatment for extraction. In Section V, the Team compared the merits of these top level system configurations, and developed a final system design solution based on the optimal system configuration.

### **C. REFINEMENT SYSTEM**

The HNAABS Project Team developed a high-level system concept for a green crude refinement system and conducted an analysis of alternatives for implementing the refinement system concept in the State of Hawaii.

The high-level refinement system concept focused on the functional and physical architecture of the system and was developed using the CORE® software-modeling tool. The refinement system developed by the HNAABS Project Team incorporates three primary functions (listed in sequence): Hydrotreat, Hydrocrack, and Fractional Distillation. The sequence in which the green crude is exposed to the functions is unique

to the refinement of green crude and is due to its high oxygen content (Wildschut, et al. 2009). From a physical perspective, a By-Product Management and Disposal Facility was incorporated in an effort to maximize system efficiency through the recycling of resources and by-products. The HNAABS refinement system concept was optimized for the production of bio-kerosene from algae-based green crude.

The HNAABS Project Team considered three alternatives for implementation of the refinement system concept. The three alternatives were to retrofit a petroleum crude refinery, build a new green crude refinery, and construct a hybrid refinery. The hybrid refinery alternative called for the building of a new green crude refinery onsite to an existing petroleum refinery. This alternative allowed for the sharing of existing resource infrastructure and processing of green and petroleum crude in parallel. The HNAABS Project Team concluded that the implementation alternative with the lowest risk and highest cost effectiveness was the hybrid alternative.

The following section presents the details of the high-level refinement system concept and detailed analysis of implementation alternatives that was conducted by the HNAABS Project Team.

## **1. Background**

The green crude produced by the cultivation system is an unfinished and unusable substance in the eyes of the aviation community. To use the oil in aircraft turbine engines, it must meet the MIL-DTL-5624U (JP-4 and JP-5) and MIL-DTL-83133H (JP-8) specifications. These specifications are approved for use by all DoD departments and agencies. The green crude product of the HNAABS cultivation system must be refined by a Refinement System to satisfy the aviation grade turbine fuel specifications of MIL-DTL-5624U and MIL-DTL-83133H.

The primary purpose of the HNAABS refinement system is to receive the algae-based green crude produced by the HNAABS cultivation system and refine it into a useable bio-kerosene.

From an academic perspective, the primary purpose of the HNAABS Capstone project in regards to the refinement system was to determine the feasibility of implementing a commercial scale algae-based bio-oil refinery in the State of Hawaii. A secondary purpose of the project was to develop a green crude refinery system concept. In order to complete the feasibility study and develop a system concept, the team considered the stakeholders' needs, derived system requirements, system functional architecture, system physical architecture, as well as system alternatives. The primary evaluating factors in the feasibility study were cost and performance with consideration given to other factors as well.

*a. Refinement History and Progress*

Refineries have been exploiting evolving technologies and process efficiencies to produce petroleum based fuels for more than 100 years. The HNAABS refinement system is seeking to incorporate such technologies from the history of petroleum refining and apply it to green crude refining. A green crude refinery has a lot in common with a petroleum refinery in terms of process and architecture; however, there are some significant differences that make it difficult to retrofit a petroleum refinery into a green crude refinery.

From an oil refinement perspective, one of the most significant differences between algae derived green crude and petroleum crude is the oxygen content. Green crude has a significantly higher oxygen content, which makes it less stable than petroleum crude (Phukan, et al. 2011) (Speight 2007). In order to make the green crude more stable, an extra step, called hydrodeoxygenation, is necessary in the refinement process to remove the oxygen. The increased oxygen content also creates a storage problem. The higher oxygen content makes the crude more acidic, which can cause serious corrosion issues in storage units and facilities (Xu, et al. 2011). A more detailed discussion on the differences between green crude and petroleum crude is included in Section III.C.7, System Alternatives Analysis.

As the bio-fuel industry continues to expand in size and technological maturity, bio-fuel will continue to strive to become more competitive with petroleum fuel

from both a cost and performance perspective. However, until bio-fuels are cost competitive with petroleum fuels for everyday consumers, the petroleum industry will continue to focus their commercial scale oil refinement on petroleum crude oil. Thus, there is very little information and data on the operation and infrastructure associated with a commercial scale green crude refinery as the vast majority of green crude refinement is conducted on a small scale through research and development projects.

Currently, only one commercial scale refinery in the United States is dedicated solely to the refinement of biofuels (Dynamic Fuels, LLC 2010). This refinery, in Geismar, Louisiana, is owned and operated by Dynamic Fuels, LLC and was designed specifically for the refinement of biofuels (Dynamic Fuels, LLC 2010). Although other refineries and companies are working towards expanding their biofuel refinement capacity, the Dynamic Fuels facility is the first and only in the United States to have a commercially scaled biofuel refinement process (Dynamic Fuels, LLC 2010). The commercial scale should help make the biofuel products more competitively priced with petroleum fuel products. However, a large price difference between petroleum jet fuel and bio-jet fuel still exists. In December of 2011, Dynamic Fuels sold 450,000 gallons of biofuel to the U.S. Navy at a price of \$26 per gallon (Stillwater Associates 2013), and the average price of petroleum jet fuel at the time was approximately \$2.87 per gallon (IndexMundi 2013). Furthermore, the Dynamics Fuels facility is a ‘small’ refinery in comparison to large oil company refineries, such as Exxon, BP, Shell, etc. While the large oil company refineries have some throughputs in excess of 200,000 barrels per day, or approximately 3 billion gallons per year, the Dynamic Fuels refinery has a daily throughput of 5,000 barrels per day, or approximately 75 million gallons per year (Dynamic Fuels, LLC 2010). From a size and throughput perspective, however, the Dynamic Fuels refinery is comparable to the requirements for HNAABS. The Dynamic Fuels refinery is capable of processing a wide variety of feedstocks, including algae based green crude, although its primary feedstock is animal fats, greases, and vegetable oils (Dynamic Fuels, LLC 2010). This refinery produced jet fuel that was tested in U.S. Air Force aircraft engines with positive results (Brown 2009). The team expects this fuel

will satisfy United States DoD military specifications when the MIL-HDBK-510 Alternative Fuel Certification Process is complete.

The Dynamic Fuels facility provides a proof of concept to the unique system requirements of the HNAABS refinement system. The facility demonstrates that the unique processes and architecture required can be effectively scaled to a commercial size which is capable of producing bio-fuel in large quantities. In the State of Hawaii, a similar system could exist through the retrofitting of a current petroleum refinery already constructed and operating in Hawaii, or through the building of a new refinery designed specifically for the refinement of algae-based green crude. Section III.C.7, System Alternatives Analysis, discusses the advantages and disadvantages of both alternatives as well as a third hybrid alternative.

***b. Scope***

HNAABS incorporates a system of systems approach. Thus, it was essential to define a clear scope between the key lower-level systems: Cultivation and Refinement. From a high-level perspective, the refinement system is responsible for receiving the green crude from the cultivation system and refining it into useable aviation grade bio-kerosene. The scope of the HNAABS refinement system neither includes the transportation of the crude oil nor the final bio-kerosene product for use as an aviation fuel by USPACOM. The refinement system's scope is to produce a bio-kerosene product that can be varied for compatibility and blending with either JP-5 or JP-8 petroleum jet fuel depending on the current demand. Determination of the specific blending ratio is not within the scope of this report, but is discussed in the report generated by the NAVSEA Capstone team. The process and infrastructure necessary to blend the bio-kerosene with petroleum based jet fuel, is also not in the scope of this report.

The scope of the refinement subsystem, as it pertains to this report, centers on the functional and physical architecture that is required for a refinery that produces a minimum of 32 million gallons per year of algae-based bio-kerosene. This number derived from calculating 25% of the yearly aviation fuel consumption by USPACOM in Hawaii. This includes the architecture for the refinement of other biofuel by-products (i.e.

bio-diesel) and a By-product Recycling and Disposal Facility. The refinery system concept also considers energy utilization, water utilization, land usage, and environmental impacts.

*c. Hawaii Oil Refinement Situation*

There are two commercial size petroleum refineries in the state of Hawaii, Tesoro (which is closing (Shimogawa 2013)) and Chevron. This section discusses the capabilities and details of each refinery.

(1) **Tesoro Refinery.** The Tesoro Hawaii Corporation (Tesoro) is a wholly owned subsidiary of the Tesoro Petroleum Corporation acquired from BHP Americas in 1998. The refinery is located at the southwestern tip of Oahu, Hawaii, about 24 miles west of Honolulu, on the 203 acres of the Campbell Industrial Park, Kapolei, Hawaii site. This complex has a 95,000 barrel-per-day petroleum refinement capacity, a 5.2 million barrel storage tank capacity for both crude and refined products, and support buildings. (Hawaii Foreign-Trade Zones 2013) The refinery is about 20 times the size expected for HNAABS; however, Tesoro is still considered a medium-sized, medium-complexity facility with a distillate-focused yield. Using crude oils from the Middle East, Australia, and Southeast Asia the refinery has the capability to produce gasoline, gasoline blendstocks, jet fuel, diesel fuel, heavy fuel oils, liquefied petroleum gas, liquid asphalt, and naphtha. Tesoro creates a myriad of products. Table 61 displays the refinery's crude unit daily average throughput (Hawaii Foreign-Trade Zones 2013).

Throughput Type	Barrels Per Day
Total Throughput (all sources)	89,135
Total Crude Oil Throughput	87,830
Total Other Throughput (slop oil / off-test products)	1,305
Total Foreign Oil Throughput	73,237
Current Rated Capacity of Refinery	95,000

Table 61. Tesoro refinery average daily throughput capacity (From Hawaii Foreign-Trade Zones 2013).

Of the output of the processed crude, approximately 94% are Non-Privileged Foreign (NPF) attributed products such as gasoline, jet fuel, diesel, and residual fuel oil. These products are sold as wholesale gasoline and diesel for motor vehicles, commercial and military airplanes for jet fuel, and electric power producers and marine vessels for residual fuel oils. The remaining output of the processed crude, approximately 6%, goes to NPF attributed crude oil such as asphalt, propane, fuel gas, and naphtha. Recipients of these products include asphalt paving companies, propane wholesalers, Tesoro (for fuel gas), and a synthetic natural gas manufacturer (for naphtha). Table 62 represents a breakdown of Tesoro’s product exports (note the table utilizes API units, which is a unit of measurement that compares the density of a petroleum liquid to the density of water). The Tesoro facility employs approximately 700 employees, 250 of which are directly employed by Tesoro. (Hawaii Foreign-Trade Zones 2013).

Export Description	Quantity
Export of Total Production	19% (10% Direct, 9% Indirect)
Volume of Total Crude Oil Receipts on an Average Daily Basis	88,244 Barrels Per Day
Volume of Foreign Crude Oil Receipts on an Average Daily Basis	72,814 Barrels Per Day
Estimated Foreign Crude Receipts under 25 degrees API	22%

Table 62. Tesoro export data (From Hawaii Foreign-Trade Zones 2013).

The Tesoro refinery is a consideration for co-locating with a green crude refinery for HNAABS. Section III.C.7, System Alternatives Analysis discusses the benefits and challenges of co-locating an existing refinery in Hawaii; however, specifics of the Tesoro refinery will be given as an overview here.

An advantage to using the Tesoro Kapolei site is the existence of key infrastructure (plot space, feed/product tank farm, hydrogen (H<sub>2</sub>) supply network, utilities, control systems, etc.). Also, environmental and government regulations, like the Foreign-Trade Zone (FTZ), have been established. The FTZ has improved Tesoro's competitive position within industry by reducing operating costs, improving margins, and enabling more effective foreign market competition. Tesoro's annual FTZ savings estimate to be \$1million. An FTZ also offers cash flow savings by deferring paying customs duties and fees on imports of crude oil and other refinery feedstocks. (Hawaii Foreign-Trade Zones 2013).

There may also be government incentives to leverage by co-locating a green crude refinery with Tesoro. For example, the Renewable Fuel Standard (RFS) Environmental Protection Agency (EPA) program established renewable fuel volume mandates in the United States, which drive incentives/subsidy support for the production of biofuels in the United States (U.S. Environmental Protection Agency 2013).

There are also risks with co-locating a green crude refinery with Tesoro. To produce a return on investment requires either continuing government incentives or cost reductions in the process. This would warrant further optimization research including feedstock availability, viability, and an economically feasible feedstock. Feedstock research is necessary as refineries experience rapid swings in feedstock prices and demands. In addition, building a smaller scaled test plant could confirm algal feed yields before proceeding with further refinery design modifications, particularly if algal Fatty Acid Methyl Esters (FAME) remain a baseline feed source.

In 2012, Tesoro announced a business plan to dispose of its Hawaii assets, including the refinery, due to economic hardships and rising competition. Without a buyer, on January 8<sup>th</sup>, 2013, Tesoro announced the closure of the refinery to leverage other business alternatives. Operations will cease in April and the refinery will convert into an import, storage, and distribution terminal. The Tesoro refinery will become the seventh Western Hemisphere plant since 2009 closed and converted to a terminal. This allows Tesoro to compete in mid-stream logistics, which includes terminals and

pipelines, and operate on a fee-based model not exposed to rapid swings in feedstock prices and demands. (Shimogawa 2013).

(2) **Chevron Refinery.** Chevron is the second-largest integrated energy company and the third-largest hydrocarbon producer in the United States (Chevron 2012). They specialize in the production of crude oil, natural gas, and similar products. One of the five U.S. refineries operated by Chevron is located in Honolulu, Hawaii. Chevron's experience there may be predictive of the possibilities and obstacles for HNAABS. This section summarizes the existing Chevron refinery and lessons learned while establishing a facility there.

Chevron's refinery was developed in 1962 with an initial capability to process 33,000 barrels of crude oil per day (University of Hawai'i Economic Research Organization 2013). Innovations in technology, improvements to equipment, and expansion of the facility have increased the refinery's capacity to approximately 60,000 barrels of crude oil per day (Hawaii Foreign-Trade Zone 2013). The refinery uses 14 different types of crude oil from several areas throughout the Pacific Rim to meet its capacity. The primary input is a more expensive light, sweet crude oil (A Barrel Full 2013). For perspective, this is approximately fifteen times larger than the approximate 3900 barrels per day the HNAABS refinement system is required to process.

Chevron's refinery is located on approximately 250 acres of land. This space accommodates the refinery's facilities including a crude unit, fluid catalytic cracking unit, and auxiliary units (Hawaii Foreign-Trade Zone 2013). The Chevron facility is lacking hydrocracking capability, which is a consideration in co-locating HNAABS to this site, as this is a vital process in refining green crude. In addition, the infrastructure modifications for hydrocracking may not be economically viable for conversion.

Chevron's facility does have a majority of the infrastructure in place required for HNAABS, such as the refinery tank field with a storage capacity of around 3.9 million barrels of crude and distillation units (Hawaii Foreign-Trade Zone 2013) (A Barrel Full 2013). Table 63 shows some of the refining units that Chevron utilizes in Hawaii to process crude.

<b>Refining Unit</b>	<b>Capacity (barrels per day)</b>
Atmospheric Distillation	54,000
Vacuum Distillation	31,000
Fluidised Catalytic Cracker	22,000

Table 63. Refining units processing capabilities at Chevron Hawaii refinery (From A Barrel Full 2010).

Chevron employs approximately 300 people consisting of technical professionals, clerical staff, skilled tradesmen, and laborers to support maintenance and capital projects. Approximately 66% of the personnel employed by Chevron are fulltime while the remaining are contractors (Hawaii Foreign-Trade Zone 2013).

The products produced by Chevron’s refinery are exported across the globe and are critical to the local community, due to the limited resources for power and fuel. Table 64 details some of the products produced at Chevron’s refinery. HNAABS will consider impacts on all the vital social and economic products for the business success of a green crude refinery.

<b>Hawaii Refinery Product</b>	<b>Possible Applications</b>
Motor Gasoline	Automobiles
Aviation Gasoline	Small Aircraft
Jet Fuel	Commercial Airlines
Diesel Fuel	Marine Vessels
Liquified Petroleum Gas	Homes and Industry
Fuel Oils	Electricity and Industrial Power
Asphalt Emulsion	Road Construction

Table 64. Example of Chevron’s Hawaii refinery products and applications (After Hawaii Foreign-Trade Zones 2013).

The products produced at Chevron’s refinery are transported via a network of pipelines or tank trucks to local services and shipyards, where they are exported. Resources are similarly imported. Government processes and regulations have monitored Chevron’s operations for environmental and social reasons. The location of a

refinery close to the ocean is a concern and a benefit. It minimizes infrastructure impacts but increases risk of an incident having a larger impact. Chevron's facility works closely with local and federal government to ensure best business practices economically, socially, and environmentally.

(3) **Current Facilities within Hawaii.** Within the state of Hawaii, there is a combined fuel production capability of 155,000 barrels per day (down to 60,000 after Tesoro has closed down) with 9.1 million barrels of storage capacity for oil products at the refineries (down to 3.9 million barrels after Tesoro has closed down). The 3.9 million barrels of storage capacity equates to approximately 33 days of supply based on Hawaii's petroleum usage in 2008 (State of Hawaii Department of Business 2011). An additional 5.9 million barrels of strategic fuel storage exists in a Navy facility on Oahu (Navy Memories Shop 2013). This adds approximately 50 days of petroleum supply to the State of Hawaii based on the 2008 usage rate (State of Hawaii Department of Business 2011), making a total of approximately 83 days' worth of petroleum storage in the state. Tesoro and Chevron's Hawaiian facilities shed light on the obstacles, benefits, and scope that are predicative for similar refineries in Hawaii. They demonstrate the potential capacity, infrastructure, and business models that can be advantageous or less so when operating in such a precarious environment. A new bio-crude refinery can leverage the strengths and weaknesses from these facilities. After analyzing the throughput, capacity, manpower, land requirement, products, and processes, there is a foundation for building, retrofitting, or co-locating, a refinery in Hawaii. Section III.C.7, System Alternatives Analysis discusses in more detail the approach to each refinery implementation alternative.

## **2. Requirements Allocation**

The requirements for the HNAABS refinement system were derived from the problem definition, high-level system requirements, stakeholder input, and project sponsor input.

The refinement system seeks to satisfy requirements unsatisfied by any refinery (bio or petroleum) currently in existence. While the Dynamics Fuels refinery has a

primary feedstock of animal fats, greases, and vegetable oils, the HNAABS refinery has a primary feedstock of algae based green crude. Algae based green crude refinement requires the use of technology and processes previously only implemented on a small scale for research and development projects. The HNAABS refinement system realizes these processes and technologies on a commercial scale. In upsizing the refinery, HNAABS forces the development of many requirements not accounted for on the small project scale. A commercial scale green crude bio-refinery in the State of Hawaii must account for the following item requirement areas:

- Product (Bio-Kerosene) Quality
- Throughput
- By-product Management and Disposal
- Air Pollution
- Effluent Levels
- Land Usage
- Water Usage
- Power Usage
- Reliability
- Operational Availability
- Manpower

The required throughput and bio-kerosene production of the HNAABS refinement system is based on a 50/50 bio-kerosene/petroleum jet fuel blend to satisfy 25% of the annual USPACOM fuel consumption. To meet the throughput requirement, the HNAABS refinement system must satisfy the specific reliability and operational availability requirements denoted in the attached HNAABS Performance Specification document (See Appendix A).

Conversations with HNAABS stakeholders and statements from a local Hawaii public forum meeting attended in September 2012 by representatives on the HNAABS Team concluded that residents of Hawaii take a great interest in the impacts of projects in their state. The impacts of projects, combined with the limited amount of resources available on the tiny island state, lead to intense scrutiny of the land, water, and power

usage requirements of commercial scale projects. The land in Hawaii is predominantly owned by family and state trusts, which retain ownership by leasing the land for commercial and residential development. There are also many protected historic and religious sites. All of these issues have a significant impact on the placement of a refinery, and are atypical issues when compared to popular refinery locations in the Continental United States such as Texas and Louisiana.

The pollution and by-products produced during the refinement of green crude are more environmentally friendly than petroleum crude. The pollutants contained in petroleum-based products are one of the most significant sources of pollution in the world (Advameg, Inc. 2013). The bio-fuel process also recycles some of the by-products back into the refinement process. The HNAABS refinement system will be required to comply with all the same Hawaii environmental codes and regulations as a petroleum refinery. Satisfaction of these requirements should be less difficult due to the natural composition of the green crude.

### **3. System Configuration Analysis**

A green crude refinement system requires many of the same processes utilized in a petroleum crude oil refinery. Thus, the system architecture and physical infrastructure of a green crude refinery is comparable to existing architectures of petroleum based oil refineries. An oil refinery infrastructure typically includes crude oil storage, a distillation tower for oil separation, product storage, and a number of units designed to further refine or enhance the petroleum products. Figure 76 depicts the typical oil refinery infrastructure (Britannica 2012).

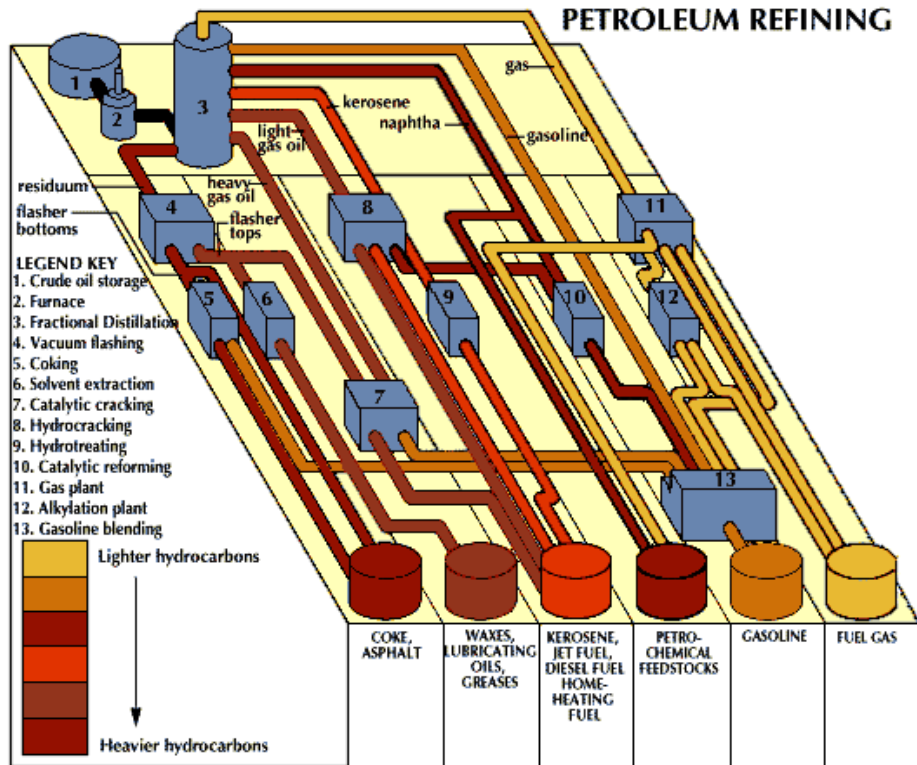

Figure 76. Infrastructure of typical petroleum crude oil refinery (From Britannica 2012).

Once transported from the cultivation site to the refinery, the green crude will be stored in storage drums prior to being hydrotreated. This storage facility will be capable of holding 1.5 million gallons of green crude delivered from the cultivation site each week.

Hydrotreating is used to remove contaminants (sulfur, nitrogen, and oxygen) from the feedstock. This process is the first step in refining the green crude. By preceding hydrocracking, the hydrotreating process is able to improve the product yields and catalyst effectiveness by reducing the organic oxygen in the feedstock, fuel contaminant content, and temperature in the hydrocracking process. Hydrotreating involves deaerating the feedstock, mixing it with hydrogen, heating it, and then pressurizing it in a catalytic-reactor. This converts the sulfur and nitrogen into hydrogen sulfide and ammonia, respectively. They are then separated via a liquid/gas separator. The sulfur by-products are scrubbed of the hydrogen sulfide gas and reused in the refinery furnaces. The final

products from hydrotreating can be further processed with reforming, catalytic cracking, or hydrocracking. (Cleveland and Szostak 2011) The discussion of oxygen removal is covered in greater detail in the Algal Oil Composition and Hydrotreating (Section III.C.4) of this report.

Hydrocracking is typically a two-stage operation. The first stage inserts hydrogen and removes sulfur and nitrogen, resulting in saturated hydrocarbons. For hydrotreated green crude, the first stage of hydrocracking is not necessary as the alkanes are already saturated and there is no sulfur and nitrogen. In the second stage of hydrocracking, high-pressure hydrogen converts hydrocarbons into easily breakable hydrogenated rings. The acid catalysts open and break the paraffinic rings to form smaller olefinic double bonds of unsaturated hydrocarbons. These mix with hydrogen gas to form alkanes of lower molecular weight comprised of mostly isoparaffins. Figure 77 shows a typical two-stage hydrocracker set up. The heavy hydrocarbons are mixed with a stream of high-pressure hydrogen flowing through a heat exchanger. There it enters the reactor and flows down through the catalysts. The hydrocracking process is customizable for different pressures, temperatures, and catalysts depending on the desired product (Dolbear 1998)

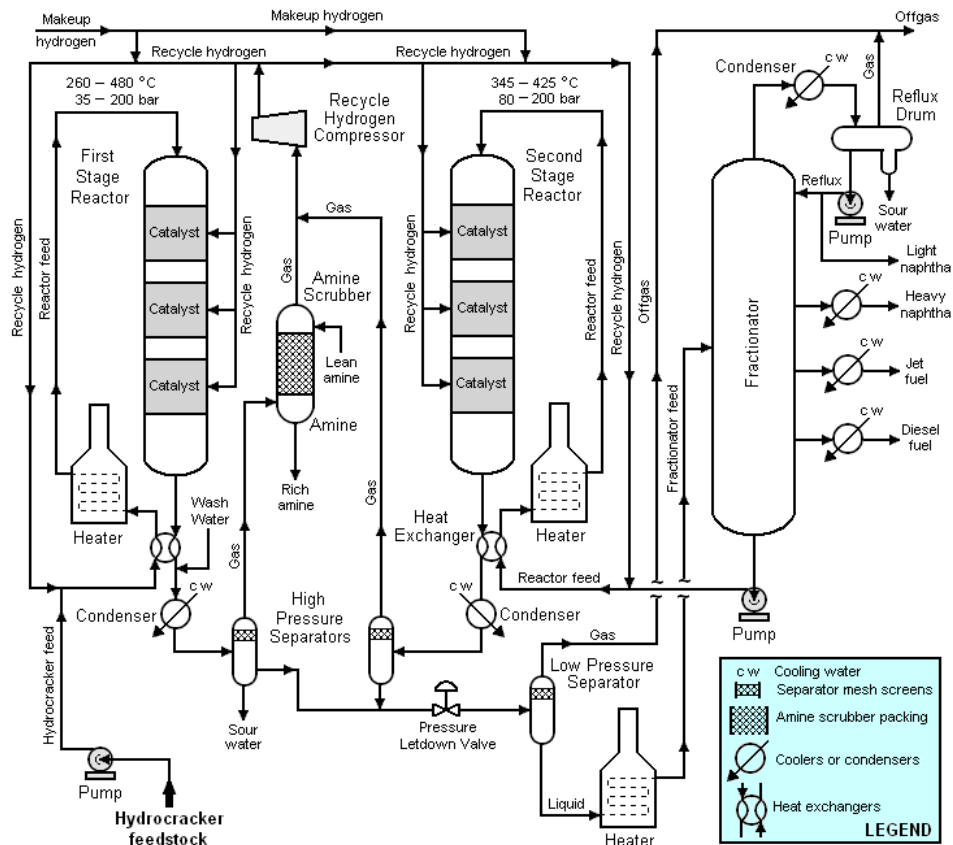

Figure 77. Typical two-stage hydrocracker set up (From Citizendum 2012).

The fractional distillation tower will perform the separation of the hydrocracked green crude into separate components based off the molecular structure and boiling point. The fractional distillation tower will heat the green crude utilizing high-pressure steam that enters from the bottom of the column. The green crude is heated, becoming gaseous when it enters the column. Internal to the column, the vapor rises through the layers of trays until it reaches its boiling point and condenses to a liquid that is collected by trays and separated from the other substances (Freudenrich 2001). The fractional distillation tower separates the distillates of jet fuel, diesel, and naphtha. Figure 78 shows a typical fractional distillation tower set up.

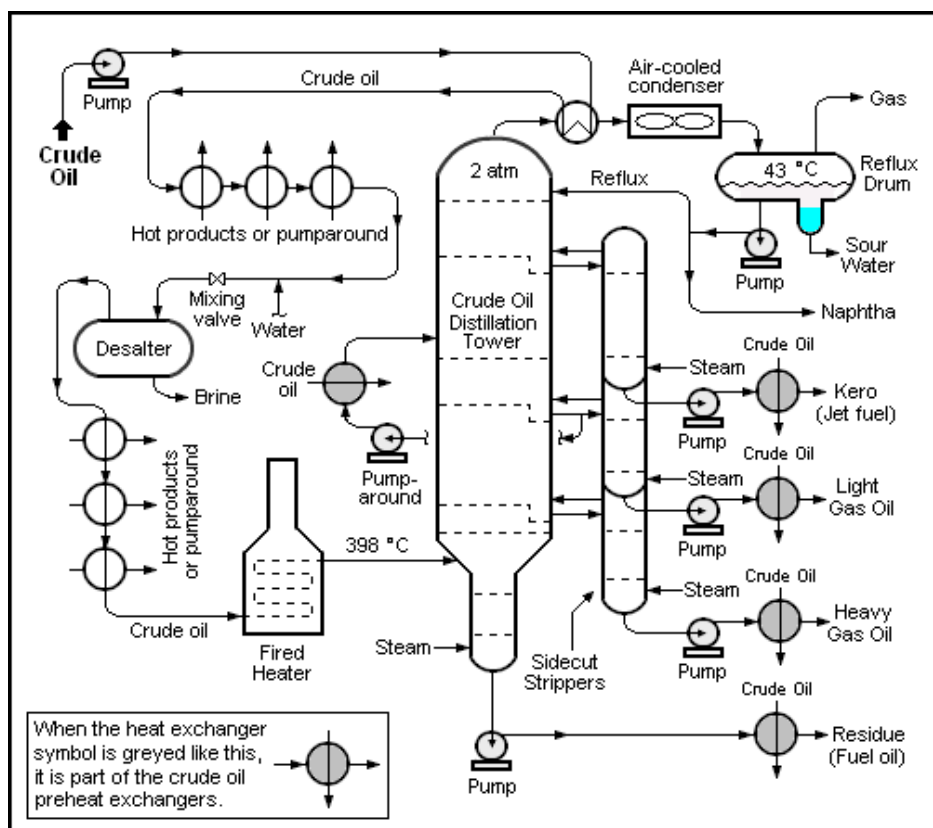

Figure 78. Typical fractional distillation tower set up (From Beychok 2013).

The streams of refined bio-kerosene from the fractional distillation tower go to the storage facility along with other biofuels produced during the refinement process. The basis of production for the overall output of different biofuels produced at the refinery is the need of resources to power the refinery and overarching consumption of the different fuels. This report does not include discussion on the additional refining capability for the enhancement and alteration of these other fuels. Figure 79 shows the physical architecture and required components of a refining facility that would be required to fulfill the need to produce bio-kerosene from green crude.

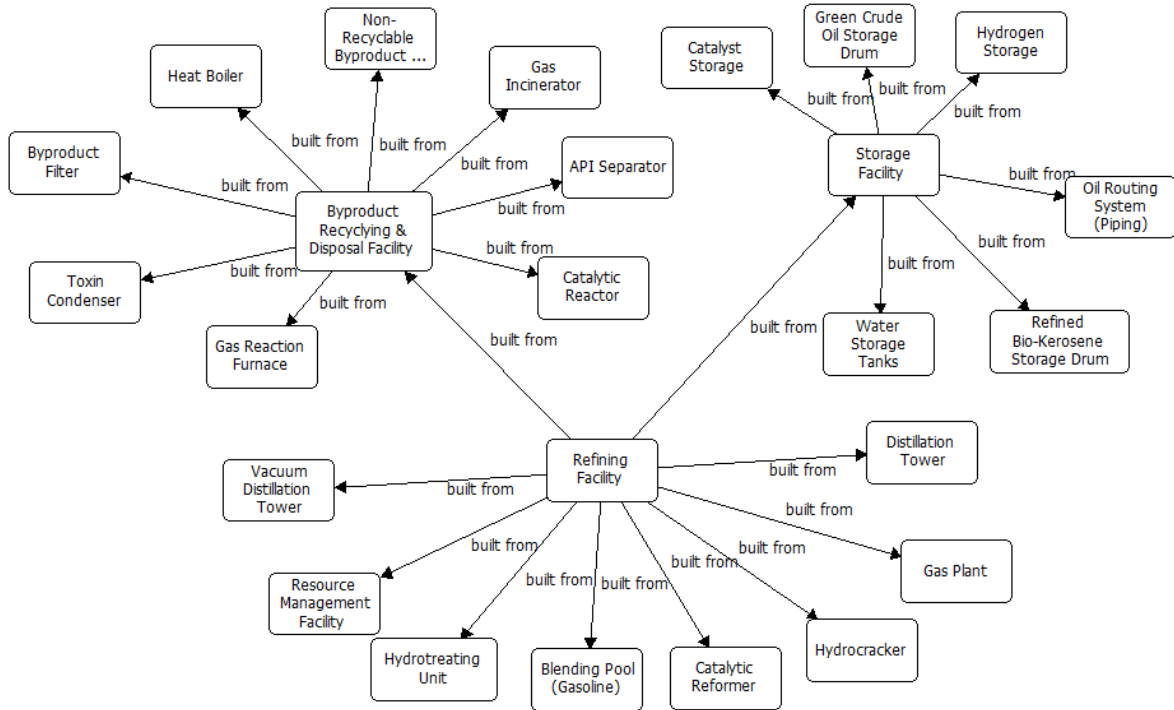

Figure 79. HNAABS refinery physical architecture spider diagram.

Figure 79 also shows the physical architecture and required components of a refining facility's By-Product Recycling and Disposal Facility that would be required for environmental regulations and resource recycling. A major facility component to control water content is the American Petroleum Institute (API) separator. This separator is used to treat the process fluid by separating oil, water and solids. Normally the API separator is followed by a secondary separation treatment step, a dissolved air flotation (DAF) or an induced air flotation (IAF) unit, which further separate the oil, water and solids (IPIECA 2010, 28). Figure 80 shows a Typical API separator.

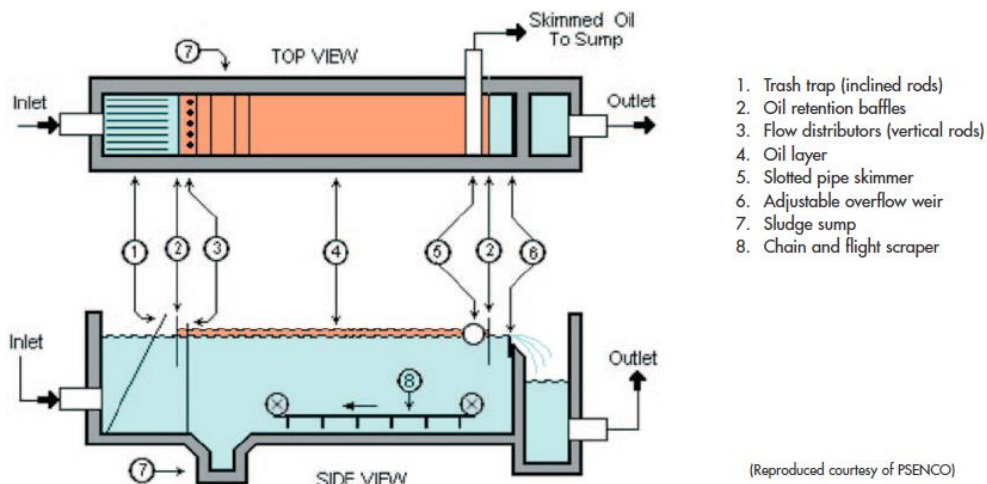

Figure 80. API separator (From IPIECA 2010, p. 28).

Filters used within the water management facility include basic media and sand filters. The filters “remove gross solids and suspended solids found in the refinery effluent” (IPIECA 2010, 44). Figure 81 shows a media filtration system.

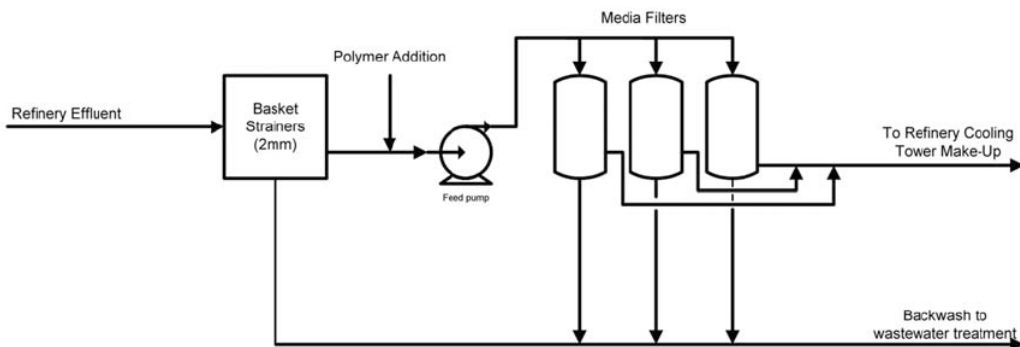

Figure 81. Media filtration system (From IPIECA 2010, 45).

#### 4. Algal Oil Composition and Hydrotreating

Significant differences exist between refining petroleum and green crude due to the green crude’s composition. Although both types of crude are comprised largely of hydrogen and carbon, they have some significantly different characteristics. While some of these differences are beneficial, many lead to negative consequences in the refining process. Green crude characteristics will vary depending on the production method and type of feedstock used. Thus it is critical to ensure that the variation in the green crude is

controlled so the final product continues to meet the end fuel specification. Table 65 shows the typical composition of green crude produced from the chosen feedstock, Chlorella compared with petroleum based oil. (Phukan, et al. 2011) (Milner 1948) (Speight 2007).

	Chlorella	Petroleum
Carbon	47.54 – 65.58	83 - 87
Hydrogen	6.88 – 9.43	10 - 14
Nitrogen	1.23 – 6.8	0.1 – 2
Oxygen	18.19 – 44.35	0.05 – 1.5
Sulfur	Negligible	0.5 - 6

\* Composition by mass percentage

Table 65. Green crude and petroleum composition (After Phukan, et al. 2010; After Milner 1948; After Speight 2007).

While petroleum crude is made mostly of hydrocarbons, green crude is more diverse and highly dependent on both the biomass feedstock and which growth and extraction technology is used (Vardon, et al. 2011). Chlorella is capable of storing varying amounts of lipids in the form of triglycerides, fatty acids, and fatty acid esters depending on the growth conditions and extraction technique. Typical fatty acids in Chlorella include palmitic and stearic acid as well as other saturated and unsaturated acids. Table 66 shows the analysis of several strains of Chlorella (Milner 1948).

	Chlorella Strain Number			
	1	2	3	4
Palmitic Acid	16.6	10.9	7.9	11.4
Stearic Acid	0.4	4.1	3.9	3.5
C <sub>16</sub> unsaturated	29.1	18.3	27.3	18.0
C <sub>18</sub> unsaturated	53.9	66.7	60.9	67.1

Table 66. Mass percentages of fatty acids in different chlorella strains (After Milner 1948).

These fatty acids consist of hydrocarbon chains tied to a carboxyl group of the form -COOH at one end (Milner 1948). They are also in the form of triglycerides (three fatty acids tied together at one end by glycerol) or as a fatty acid ester. The majority of the fatty acids found in green crude, contain hydrocarbon chains of length 16 – 18 as shown with the Chlorella strain in Table 66 (Milner 1948). It is unusual for an odd

number of carbon atoms to appear. The Palmitic and Stearic acid are saturated fatty acids, thus hydrogen atoms saturate the carbon atoms. The majority of fatty acids found in algae oil are unsaturated, containing one or more double bonds between the hydrogen and carbon atoms. Many of these unsaturated fatty acids are C18:1 and C18:3 contain a single and triple double bond (Rasoul-Amini, et al. 2011).

Chlorella and other green crude have a significantly higher level of oxygen than petroleum-based oil. This is due to the complex mixture of oxygenated compounds and carboxyl acids and glycerol attached to the oils lipids (Vardon, et al. 2011). The high oxygen content provides a potential improvement in combustion characteristics. During fuel combustion, the fuel oxidizes and parts are replaced by oxygen atoms. When combined with the higher oxygen content a reduction in carbon dioxide emissions could be realized when the green crude is burned as a fuel (Easterly 2002). The high oxygen content, however, will also lead to a low heating value and a low flame temperature (Xu, et al. 2011).

Green crude tends to be highly reactive due to the unsaturated fatty acids' high oxygen content and electronegative property. This has a negative impact on chemical and thermal stability. The lower chemical stability also affects the ability to store and transport the green crude and the derived bio-kerosene. The thermal stability will affect the use of the bio-kerosene in a jet engine (Vardon, et al. 2011).

The lower sulfur content of Chlorella and other green crude provides benefits with lower sulfur oxide (SO<sub>x</sub>) emissions and eliminates the need of hydrotreating for sulfur removal (Easterly 2002). The increased levels of nitrogen, however, could increase the nitrogen oxide (NO<sub>x</sub>) emissions and require hydrodenitrogenation (HDN). This process involves removing the nitrogen compounds from the hydrocarbon feedstock to produce more stable and environmentally acceptable fuels. The process of hydrotreating commonly includes the combination of HDN and hydrosulfurization (HDS). Hydrotreating is an integral part of all oil refining, however, HDN has not been widely implemented due to the small fraction of nitrogen compounds present in conventional petroleum crude (Swartz 2000). Algae based green crude has the opposite with large amounts of nitrogen and negligible amounts of sulfur.

The negative aspects of using an existing petroleum refinery for the refinement of green crude stem from these inherent differences between petroleum and green crude. Green crude has high oxygen content, high total acid number (TAN), and a low heating value leading to lower stability and viscosity, and higher polarity and corrosiveness. The sections below discuss in detail these technical challenges (Easterly 2002) (Vardon, et al. 2011).

***a. Corrosion***

Green crude is more acidic than petroleum crude due to the content of volatile carboxylic acids, such as acetic and formic acid (Xu, et al. 2011). Green crude typically has a pH value between 2-3 which is similar to the acidity of vinegar (Easterly 2002). Due to the high amounts of these organic acids and water, green crude will corrode materials such as aluminum, steel, and nickel. Most refineries utilize these materials heavily throughout their infrastructure. Low carbon and low alloy steel is a very common material in holding tanks, piping, and most other refining components to mitigate corrosion. Corrosion and rust inhibitor additives also help monitor and control corrosion. The acidity and water content of green crude would cause additional constraints leading to further pretreatment of the crude and metallurgy upgrades to the refining and distribution infrastructure (Easterly 2002)

***b. Thermal Stability***

Thermal stability is one of the most important characteristics of jet fuel. The high oxygen levels found in green crude makes thermal stability a significant issue while using the derived bio-kerosene and during the refinement stages that require elevated heat levels. Thermal stability measures the ability of fuel to withstand changes related to combustion in the aviation engine while continuing to meet performance specifications. Thermal stability measures the amount of deposits produced in the engine when exposed to fuel of a specific high temperature during operations. In today's jet engines, the usage of jet fuel includes not only action as a combustible material, but also as a lubricant for secondary engine systems, and a coolant to remove excess heat. Once oil reaches temperatures beyond stability levels, it can undergo various chemical

reactions involving the hydrocarbon molecules, oxygen, and other polar compounds including sulfur and nitrogen. These reactions can result in formation of deposits within the engine and fuel lines. Hydrotreating discussed in Section III.C works to mitigate the low thermal stability of bio-fuels and the resulting deposits (Commodo 2011).

*c. Chemical Stability*

Chemical stability measures the stability of the oil while at or near an equilibrium state, such as during storage. The chemical stability needs to be adequately high that oil will not induce corrosion, decompose, polymerize, or react in other ways under normal conditions. The largest contributor to low chemical stability is the oxygen content, which can cause different reactions, particularly between the hydroxyl, carbonyl, and carboxyl groups that form other molecules with water as a common by-product (Samanya 2011).

*d. Polarity*

The high oxygen content also contributes to the polarity of the green crude. The higher polarity will cause the oil to adhere to walls of storage tanks and pipes as well as have a greater attraction for other contaminants such as water, dirt and metallic debris. The likelihood for contaminants will raise the water content along with levels of metals and minerals such as sodium, potassium, phosphorus, calcium, and magnesium. If not removed the high water content and contaminations will have a negative effect on the efficiency and life of the catalysts used during the refinement of the oil (Bunting, et al. 2010).

*e. Viscosity*

Green crude is a free flowing liquid, but its viscosity is heavily dependent on the water content of the oil. Higher water content decreases the viscosity of green crude but also lowers the heating value and energy content. The polarity of the oil attracting additional water molecules along with the hydrotreating reactions can produce significant amounts of water in the green crude that must be removed prior to further refinement of the oil.

#### *f. Hydrotreating Catalyst Optimization*

The negative aspects of green crude described above are due to the high oxygen content of the oil. The high oxygen content drives the requirement for different processing techniques than for petroleum crude. Failure to remove a sufficient amount of oxygen from the oil will result exacerbate the issues described above and reduce the likelihood the final product could meet a military specification for thermal stability. This makes the removal of oxygen an immensely important step in the refinement of green crude. The following section provides a detailed analysis on how the excess oxygen is removed. Based on the team's review of the relevant literature,  $\text{RuCl}_3$  is recommended as the most efficient Hydrodeoxygenation catalyst.

The treatment of the high oxygen content in the green crude is accomplished through a Hydrodeoxygenation (HDO) hydrotreating process. The heating value of the untreated green crude has shown to have a lower energy density (15-19MJ/kg) when compared to petroleum crude (40MJ/kg) due to the high oxygen content (Wildschut, et al. 2009). Pretreatment of the oil through HDO will upgrade the oil by removing this excess oxygen in the presence of high-pressure hydrogen (H) and a catalyst. The removal of heteroatoms, in this case oxygen (O), or nitrogen (N) and sulfur (S), will increase the energy density of the green crude as well as the subsequent fuel. Table 57 shows what the effect of a series of tests with constant temperature (752 °F) and pressure (493.13 psi  $\text{H}_2$ ), varied reaction time and variations in catalyst loading (% of catalyst per unit of reactant) can have on energy density or the higher heating value (HHV). As further illustrated in Table 57, the increased C and H levels (H/C), reduced O content (O/C), and reduced N content (N/C) lead to the treated oils having a higher energy density ranging around 41–44 MJ/kg. The highest HHV of approximately 43.8 MJ/kg is very close to that of diesel fuel (44.8 MJ/kg). (Savage 2011)

<b>Experimental Conditions</b>	<b>C</b>	<b>H</b>	<b>O</b>	<b>N</b>	<b>S</b>	<b>H/C</b>	<b>O/C</b>	<b>N/C</b>	<b>HHV (MJ/kg)</b>
752°F, 1H, 40%	78.73	11.31	6.72	3.24	0	1.72	0.06	0.04	41.56
752°F, 2H, 40%	79.22	11.26	6.65	2.87	0	1.71	0.06	0.03	41.67
752°F, 4H, 40%	80.21	11.75	4.85	3.19	0	1.76	0.05	0.03	43.02
752°F, 6H, 40%	81.22	11.85	4.83	2.10	0	1.75	0.05	0.02	43.51
752°F, 8H, 40%	81.21	11.78	4.62	2.39	0	1.74	0.04	0.03	43.45
752°F, 4H, 5%	78.27	10.78	6.97	3.98	0	1.65	0.07	0.04	40.60
752°F, 4H, 10%	78.86	11.00	6.18	3.96	0	1.67	0.06	0.04	41.26
752°F, 4H, 20%	81.73	11.51	3.08	3.68	0	1.69	0.03	0.04	43.51
752°F, 4H, 60%	80.65	11.71	5.38	2.26	0	1.74	0.05	0.02	43.02
752°F, 4H, 80%	81.02	12.10	4.89	1.99	0	1.79	0.05	0.02	43.79

Table 67. Elemental composition (wt%) and heating value of hydrotreated green crude (752 °F, 493.13 psi H<sub>2</sub>) (After Savage 2011).

The high-pressure hydrogen is used to saturate the carbon chains or free fatty acids (FFA), triglycerides (TAG) and esters to completely remove the oxygen and to form straight chain paraffins or alkanes. The alkanes are the type of hydrocarbon necessary to produce the required turbine fuel of an aviation grade. Reactions that occur during this pretreatment process, however, provide not only alkanes but CO, CO<sub>2</sub> and H<sub>2</sub>O as well. These reactions are hydrogenation, decarbonylation, decarboxylation and some polymerization reactions (Solomons 2002). Polymerization leads to carbon build up (coke) on the catalyst and requires periodic removal to ensure proper reaction yields. Table 68 shows the chemical processes of some of the expected products for the HNAABS strain of algae and the HDO process. Lighter hydrocarbons are produced if the oil is predominantly a FAME or a FFA/TAG which will produce methane and propane respectively (Gary and Handwerk 2001).

C16 FFA	→	C15 Alkane + CO + H <sub>2</sub> O
C16 FFA + H <sub>2</sub>	→	C15 Alkane + CO + H <sub>2</sub> O
C16 FFA + 3H <sub>2</sub>	→	C16 Alkane + 2H <sub>2</sub> O
C18 FFA	→	C17 Alkane + CO <sub>2</sub>
C18 FFA + H <sub>2</sub>	→	C17 Alkane + CO + H <sub>2</sub> O
C18 FFA + 3H <sub>2</sub>	→	C18 Alkane + 2H <sub>2</sub> O

Table 68. Reaction products as compiled by the HNAABS team.

The following analysis for the HNAABS Hydrodeoxygenation (HDO) system is based on the results published in Hydrotreatment of Fast Pyrolysis Oil Using Heterogeneous Noble-Metal Catalysts (Wildschut, et al. 2009). HNAABS HDO should employ a continuously stirred batch autoclave. The content is stirred with a magnetically driven gas-inducing impeller. Temperature and pressure in the reactor vessel are measured and monitored by a process control system that is fed information from the reactor pressure and temperature indicators. Figure 82 shows the batch reactor process. The reactor can be flushed with nitrogen gas and pressurized with hydrogen gas during the process. Once the reactor is heated to the intended reaction temperature, it is maintained at that temperature during the reaction.

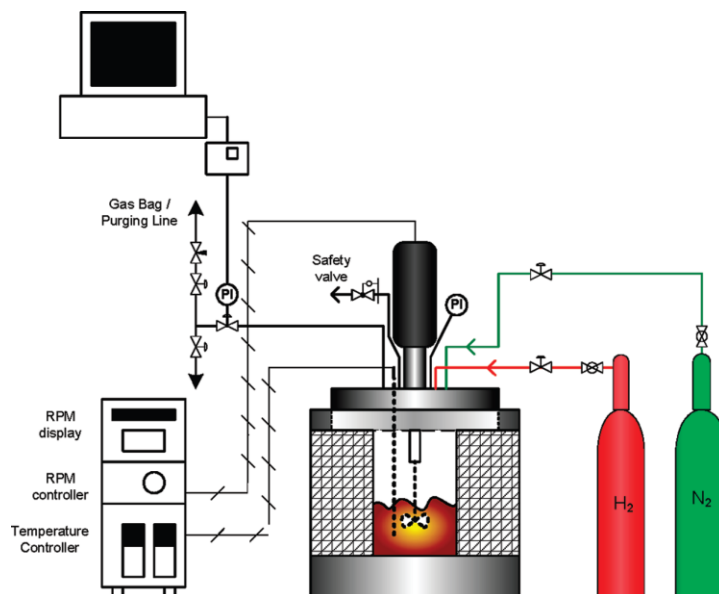

Figure 82. Example of the expected HNAABS autoclave batch reactor configuration. (From Wildschut et al. 2009)

Several different catalysts have been tested for use in the HDO process utilizing pyrolysis oil, derived from beech wood and a variety of noble-metal catalysts (Ru/C, Ru/TiO<sub>2</sub>, Ru/Al<sub>2</sub>O<sub>3</sub>, Pt/C, and Pd/C) (Wildschut, et al. 2009). They were then compared to typical hydrotreatment catalysts (sulfide NiMo/Al<sub>2</sub>O<sub>3</sub> and CoMo/Al<sub>2</sub>O<sub>3</sub>). The reactions ran at 482 °F and 1,450.4 psi for mild HDO conditions and at 662 °F and 2900.7 psi for deep HDO conditions. Each reaction was run for 4 hours. The mild conditions resulted in two liquid phases; a yellowish water phase and a brown oil phase, and some solids. The deep conditions resulted in three different liquid phases; a somewhat yellow aqueous phase and two oil phases, and some solids. Results from the two different conditions are provided in Figure 83.

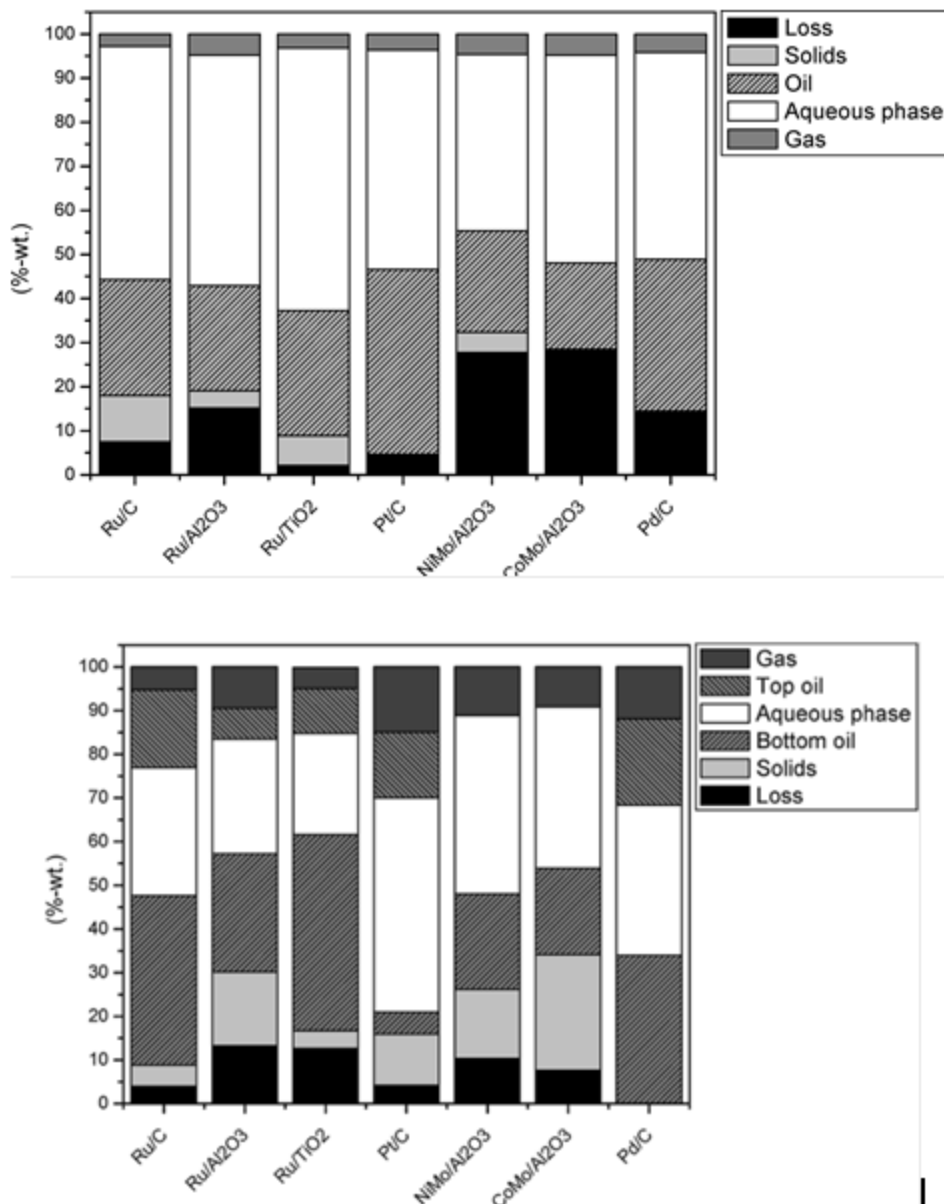

Figure 83. Reaction product comparison between mild (top) and deep (bottom) which illustrates less loss of product with the deep conditions (From Wildschut et al. 2009)

The oil yields under mild conditions range between 21 and 58 wt %. The highest yield of oil was obtained with the Pt/C catalyst but it remained high in oxygen content. Yields for the sulfidized CoMo and NiMo were at the lower end of the oil yield range with oxygen content between 24 and 26.5 wt %. The Pd/C catalyst had the lowest oxygen content. Thus, the Pd/C catalyst is the best combination of high oil yield and low

oxygen content under the mild process. The Pt/C catalyst gave the highest yield at 57 wt% but the oxygen content was relatively high at 25 wt %. Under deep conditions, the oxygen content of the various oils varied between 6 and 11 wt %. The Ru/C catalyst provided the lowest oxygen content and sulfidized NiMo/Al<sub>2</sub>O<sub>3</sub> provided the highest. All indicators from the study “Hydrotreatment of Fast Pyrolysis Oil Using Heterogeneous Noble-Metal Catalysts” point to sulfidized catalysts NiMo and CoMo on alumina as being less active in hydrotreating pyrolysis oil when compared to noble-metal catalysts (Wildschut, et al. 2009). Their activity and stability are likely reduced by the absence of sulfur in the feed, a necessity for good performance. Figure 84 illustrates the yields for the two reaction conditions.

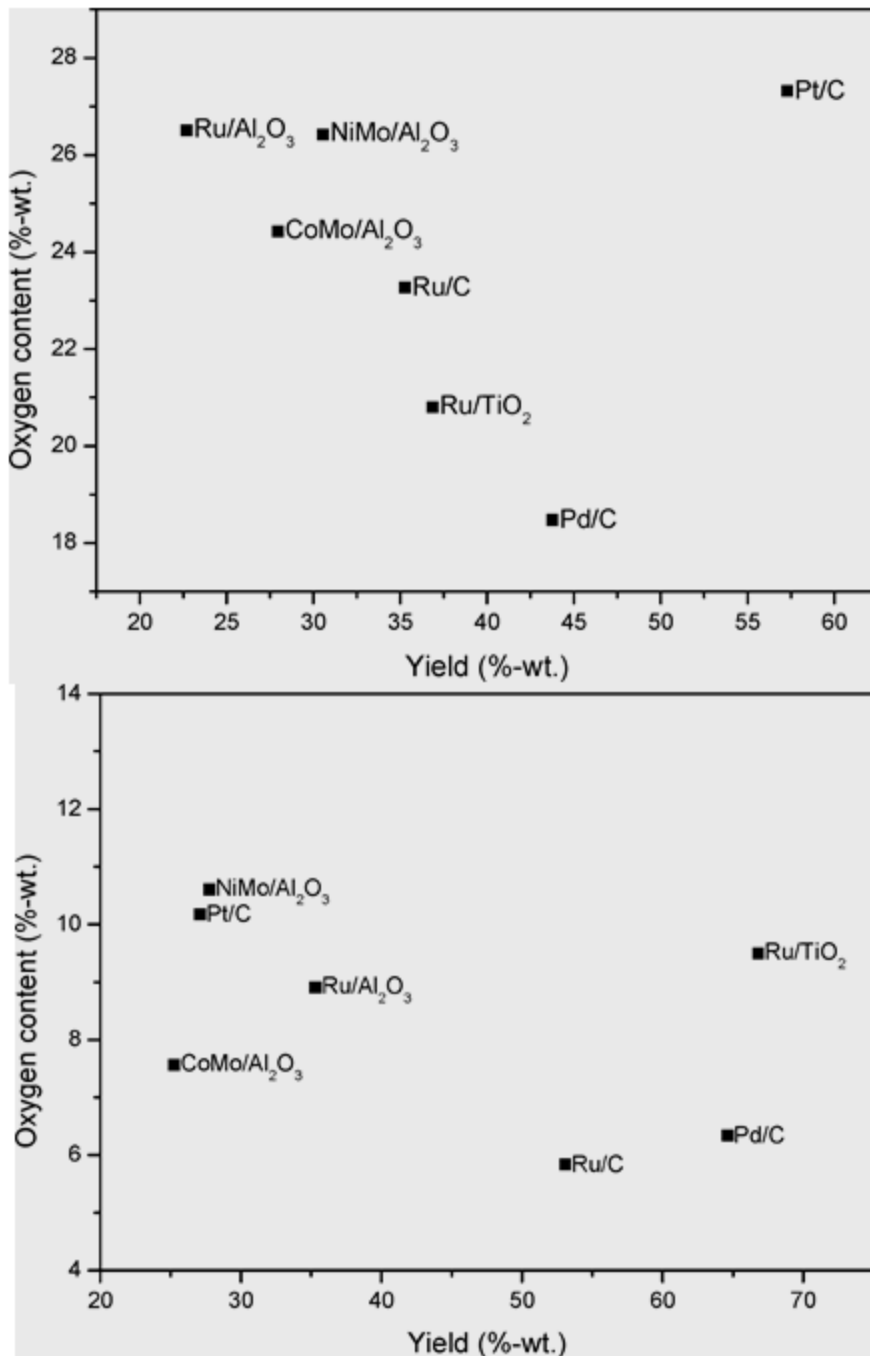

Figure 84. Reaction yield comparison between mild (top) and deep (bottom) that shows Ru/C provides the lowest oxygen content/yield percent under deep conditions (From Wildschut et al. 2009)

The catalyst screening study illustrated distinct differences in catalyst performance, product yield, and product properties for mild and deep hydro-treatments.

Under mild conditions, a single product oil with an oxygen content between 18 and 27 wt % was obtained in yields between 21 and 55 wt %. The results showed that both the yields and levels of deoxygenation were higher for noble-metal catalysts than for other more common hydrotreatment catalysts (Wildschut, et al. 2009). The deep conditions resulted in two product liquids with noble-metal catalysts. The oxygen levels of the product oils were between 5 and 11 wt %; considerably lower than obtained by the mild process. The HNAABS HDO reactor will use the mild process with the Ru/C catalyst due to lower oxygen contents. The oil yields, deoxygenation levels, and extents of hydrogen consumption make Ru/C the best for HNAABS. Although Pd/C showed a potential to provide higher oil yields than Ru/C, it had higher oxygen content and greater hydrogen consumption.

In a separate study of the Ru/C catalyst, reaction times on oil yield and product properties were determined. An optimal oil yield was observed at 4 hours in an autoclave at 662 °F and 493.13 psi. Any longer reactions produced inefficiencies due to gasification and solids formation of up to 5.3%-wt. (Wildschut, et al. 2009). The catalyst was run through the hydrotreatment process at different loads and determined that a 5%-wt. RuCl<sub>3</sub> displayed the best Hydrogen/Carbon (H/C) ratio of the product, lowest decrease in surface area (from the Brunauer-Emmett-Teller (BET) method), and lowest dispersion after the catalytic reaction.

## **5. Resource Utilization**

### ***a. Energy Utilization***

Oil refining is the most energy intensive industry in the United States, accounting for 7.5% of the total U.S. energy consumption (U.S. Energy Information Administration 2004). According to the Manufacturing Energy Survey (MECS) the U.S. petroleum refining industry used approximately 6.6 quadrillion Btu ( $10^{15}$  Btu) in 2006. Figure 85 shows a breakout of this energy.

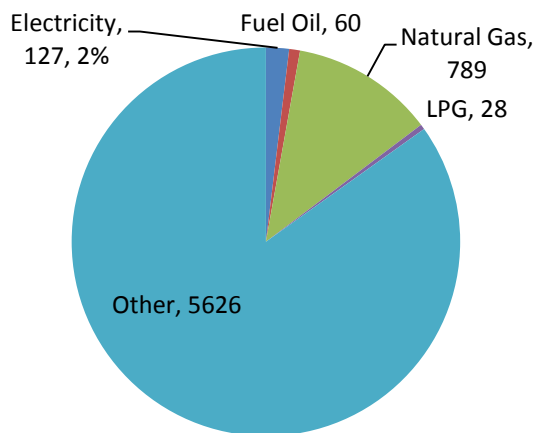

Figure 85. Energy consumed by the petroleum industry (trillion Btu)  
(From U.S. Energy Information Administration 2006).

Figure 85 excludes inputs and feedstock converted to other energy products. Only energy required for producing the heat and power to refine the petroleum products is included. The ‘other’ section of the pie chart includes recaptured steam and energy internally generated at the refinery and accounts for 85% of the energy consumed. Refineries generate approximately 32% of their required electricity and 60% of their total required energy on site (U.S. Energy Information Administration 2004).

Due to the lack of data available for energy usage of commercial size bio-fuel refineries, the HNAABS Project Team utilized available data for similar processes for calculating energy requirements for this refinement system. Using estimated average energy consumption for specific refining processes including hydrotreating, hydrocracking, and fractional distillation from the Department of Energy, the Team estimated the system will require 2.62 MJ/kg (3.3 kWh/gal) of green crude refined. This estimate includes the total energy consumed for the heating and power requirements for deriving bio-kerosene from green crude, including internally generated heat and electricity. This estimate does not include hydrogen requirements, or other supporting processes including cooling, by-product management processes, resource recycling, hydrogen production, or other overhead costs. This estimate is slightly higher than the estimate of 1.51 – 2.07 MJ/kg (1.9 – 2.6 kWh/gal) for the conversion of petroleum crude to kerosene. The higher estimate accounts for additional hydrocracking requirements

from the high number of heavy hydrocarbons produced by algae oil. A full discussion of the energy content of the bio-kerosene itself can be found in Section V.B.

Hydrogen is used in a wide range of processes during oil refinement from the removal of oxygen and heteroatomic compounds to the breaking down of larger hydrocarbons. The Department of Energy Manufacturing Energy Consumption Survey does not record the use of hydrogen as an energy input making exact hydrogen use difficult to estimate. The Department of Energy does track the hydrogen production capacity of facilities in the United States. In 2006 the oil refining industry produced an estimated 2.723 million metric tons of hydrogen and purchased an additional 1.264 million metric tons for a total of approximately 3.987 million metric tons of hydrogen (U.S. Energy Information Administration 2008), while refining a total of 5,694,730 barrels of oil (“Annual Energy Review,” Department of Energy 2012). These numbers yield a requirement of approximately 550 cubic feet of hydrogen per barrel for the U.S. refining industry. The world's refining hydrogen consumption is an estimated 12.4 billion cubic feet per day or 100-200 cubic feet per barrel (Xebec Adsorption Inc. 2013). The discrepancy between these numbers is attributed to the difficulty in accurately measuring hydrogen use, lack of sufficient data, and high inconsistency of hydrogen required for refinement in oil feedstock variances. The hydrogen requirement is highly driven by the length of the contained hydrocarbons, amount of heteroatomic compounds, and final distillates required (Viets, et al. 2012).

A common way for refineries to supply their hydrogen requirements is through steam reforming of hydrocarbons. Steam reforming can be used to extract hydrogen from fuels of shorter length hydrocarbons such as natural gas, methane, or naphtha. At elevated temperatures, these gases react with steam to produce hydrogen and carbon monoxide. In a second stage carbon monoxide reacts with water at lower temperatures to produce additional hydrogen and carbon dioxide. Figure 86 shows the general form of these chemical reactions (U.S. Department of Energy 2012).

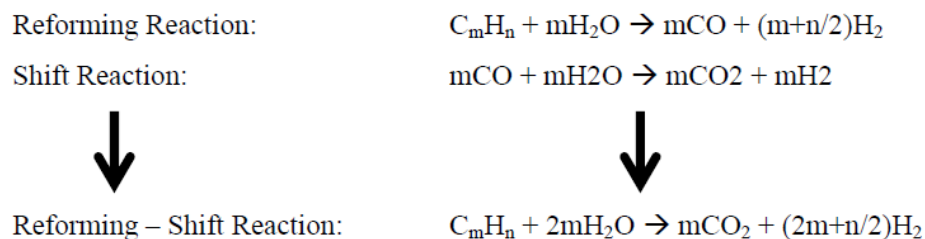

Figure 86. Hydrogen supply chemical reactions (From U.S. Department of Energy 2012).

The process of creating hydrogen from hydrocarbons allows the refinery to make cost tradeoffs when choosing between either purchasing hydrogen and selling the fuel produced by these hydrocarbons or utilizing them for hydrogen production. Hydrocracking of green crude often results in production of naphtha. Most of the hydrocarbons in algae green crude are of length C16 – C18 and are naturally in the diesel fuel range. When hydrocracking green crude to maximize the production of jet fuel, the amount of hydrocarbons lost to naphtha and other light gases will be higher. The excess naphtha produced during hydrocracking provides the refinery an option to produce the hydrogen required and cycle it back to hydrotreat or hydrocrack the green crude.

***b. Water Utilization***

Processing crude oil requires a significant amount of water and varies depending on the configuration of the process, complexity of the system, local water resources and the capability to recycle water. An accurate assessment of the water consumed in refining green crude is not discussed in this report since the exact system configuration is not specified. A high-level estimate is given based on published reports of existing petroleum refineries. To further refine this estimate, the full system design, including piping length and subsystem part number would have to be defined.

According to the United States Environmental Protection Agency (EPA), refineries use about 42 – 105 gallons of water per barrel of product refined primarily for cooling and processing (U.S. Environmental Protection Agency 2012). A similar report, “Energy and Environmental Profile of the U.S. Petroleum Refining Industry,” prepared for the Department of Energy Industrial Technologies Program indicated that refineries

use 65 – 90 gallons of water per barrel of crude oil processed. The amount of water discharged is estimated to be 20 – 40 gallons per barrel of crude (Pellegrino, et al. 2007). To reduce variability in the assessment, HNAABS used a high-level estimate of 75 gallons of water per barrel of crude oil processed along with 30 gallons of discharge water per barrel of crude. These numbers are applicable to the cost assessment of the refinery discussed in Section V.B, Feasibility and Cost Analysis of this report.

Water is used and produced in several steps of the refinement process depending on the refinery’s configuration. Crude distillation and fluid catalytic cracking consume the majority of the water for steam and cooling purposes. Approximately half of refinery water requirements are driven by the cooling tower. Figure 87 displays these associations along with other water requirements in a typical refinery. (Wu and Chiu 2011).

### Typical Refinery Water Requirement

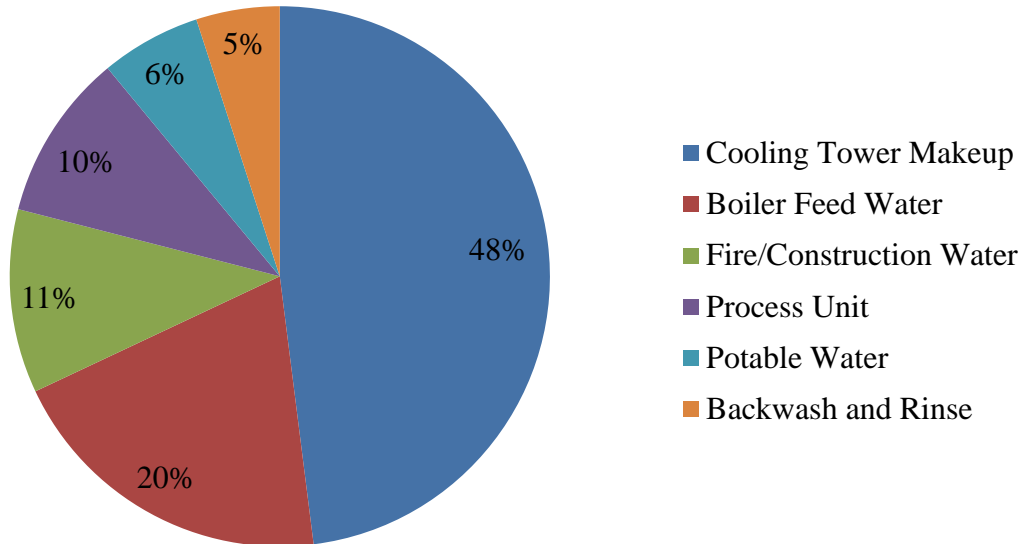

Figure 87. High level view of water requirements in a typical refinery (From Wu and Chiu 2011).

To supplement the high water requirement, multiple sources are exploited such as underground water, canals, lakes, or municipal water supplies. Seawater can replace the majority of the need for fresh water due to its ability to feed cooling

processes. Thus, developing a refinery near the ocean coast is an advantage. However, plants using seawater for cooling are required to eliminate once through or pass through cooling for corrosion prevention and because of the heat that is released back into the seawater. This increases configuration complexity as recirculation systems need to be installed to reduce the volumes of water they draw. (California Urban Water Conservation Council 2011).

To prepare the water for use, it first needs treatment depending on the application for which it is intended. Eliminating different minerals, gases, sediments and other impurities in the water, which can reduce efficiencies in oil production, is accomplished through a progressive filtering and treatment processes. As the water is collected it is roughly filtered. This is followed by coagulation and flocculation processes, which remove the water's smaller particles and sediments. As the particles coalesce, they form larger particles known as flocs. Further filtration is done on the water and the extracted debris is sent for sludge treatment. After this process, the water is a usable source for oil production (Nabzar and Duplan 2011).

Steam is the most common form of water to assist in heat transfer, tracing lines, driving power for equipment (pumps, compressors, etc.), generating electricity, emptying equipment, and for stripping in certain processes. Steam, produced in a refinery's boilers in a superheated high-pressure form, is divided into various pressures and temperatures depending on the application. Prior to water entering a refinery's boilers the steam is often further processed to remove components and lower concentration levels. The high caloric power and thermal capacity of the steam can be corrosive, foaming, scaling, and furring if the steam is unprocessed. These conditions are all detrimental to physical components and oil production efficiencies over time. The boiler feed water network is a semi-closed loop that utilizes recycled steam as part of its intake along with new water to make up for losses. The losses occur from steam polluted by a process fluid. These polluted by-products go to a water treatment system before they are discharged (Nabzar and Duplan 2011).

Water is also used to thermally cool products being refined. Depending on the infrastructure utilized by a refinery, plants implement three general configurations in cooling. Table 69 described these configurations.

<b>Configuration</b>	<b>Process</b>	<b>Application</b>
Open Circuit	Water absorbs surplus heat in a heat exchanger and is released back into the environment where it came from with an increased temperature up to 10°C.	Rarely used due to economic and environmental factors driven by thermal discharge restrictions causing increased water consumption
Semi-Open Circuit	Water exits a heat exchanger and is sent to a cooling tower where a small proportion of the flow circulating within the cooling circuit evaporates and evacuates the heat out into the atmosphere. New water is required for any wastage and this circuit can absorb 6-10°C.	Most commonly used due to economic feasibility, low corrosion risk, and requires minimal maintenance. However, does require treatments for the make-up water which cause impurities to build up in proportion to discharge through evaporation.
Closed Circuit	A predetermined and constant volume of water is used to eliminate the heat of process fluids. Water is cooled by a series of water cooling towers allowing the circuit to absorb 10-16°C.	Requires minimal water for operation but high investment costs and rigorous water treatment beforehand to reduce corrosion, clogging or bacteria development.

Table 69. Water cooling configurations in a refinery  
(From Nabzar and Duplan 2011).

Figure 88 depicts the steam and cooling system discussed in Table 69 and how each process is integrated with each other. This is a high-level view of a typical petroleum refinery, but the Process Units block is the driver to the water system. This is what requires the water, in the various forms, to process crude oil. Figure 88 shows the forms of input and output of water and the opportunities to recycle water where possible to increase water system efficiencies.

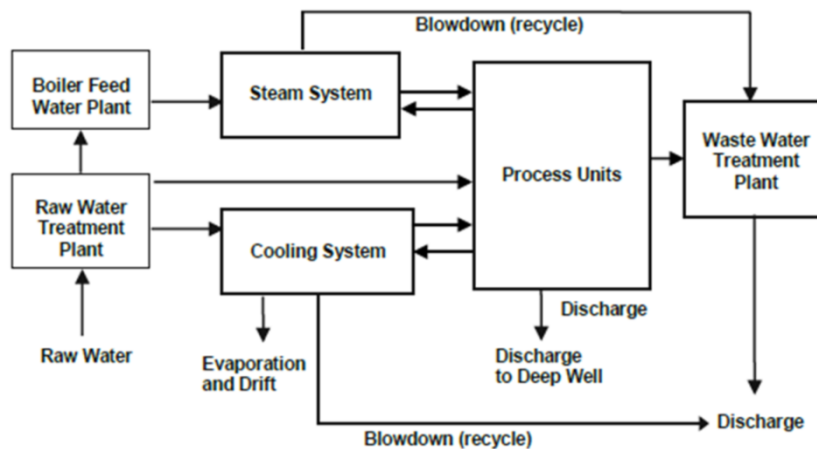

Note: Blowdowns are recycled in some facilities.

Figure 88. High level view of water system in a typical refinery (From Wu and Chiu 2011).

An efficiency gained from recycled water is the ability to feed desalters. Desalters reduce the salt content of crude oil before distillation making machinery less vulnerable to corrosion and decreasing maintenance costs during the life cycle of the refining equipment. By taking advantage of recycled water, freshwater can be saved and the discharge flow can be kept to a minimum (Nabzar and Duplan 2011).

Recycled water is recoverable from acid condensate and steam condensation that has contacted hydrocarbons during distillation, fluid catalytic cracking, hydrocracking, steam cracking, or heating products. Cracking produces the most polluted condensates due to their particular involvement in the refining process. Another source for polluted water is from maintenance of refining processes, such as washing column heads in order to reduce scaling from ammonium sulphate salts. Large sources of hydrocarbons occur from water produced by steam cracking. The heating condensates from products become polluted when they contact the hydrocarbons. Any water that has contacted the hydrocarbons, or pollutants, is treated before being recycled or discharged (Nabzar and Duplan 2011).

Before process water is treated, it is usually steam-stripped to remove pollutants and other toxins. After removing the toxins, the water is sent as washing water to the distillation units' desalters and then, finally, to the actual water treatment facility.

At the water treatment facility, water is transferred to a settling tank where it is air-stripped to remove contaminants which are incinerated after separation. After being air-stripped, the water enters another settling tank where lime is injected to support flocculation. The mineral sludge produced is extracted and sent to a sludge treatment plant. In this final stage, biological treatment is given in the form of bacteria, which use the dissolved oxygen to convert the carbon from the organic matter into CO<sub>2</sub> (Nabzar and Duplan 2011).

Petroleum refineries produce water through a Fischer-Tropsch reaction, which converts synthetic gas into hydrocarbons. However, HNAABS will generate water during hydrogenation through the hydrodeoxygenation process. This process reduces the raw water input into the refinery by recycling the produced water through the treatment process, depending on the chemical and biological processes used in the refinery (Nabzar and Duplan 2011).

Not all water utilized in a refinery undergoes the water treatment process. Non-oily water is water from sources such as domestic water, drained water from boilers and refrigeration circuits, water from laboratories, neutralized effluent, demineralization chains, and all other clean water. Non-oily water goes to a basin for monitoring of hydrocarbons before discharging into the environment or recycling back into the system, creating a more economically efficient and environmentally friendly system. Any hydrocarbons detected forces the water to be rerouted and processed as oily water.

Oily water is from sources such as water used to wash the floors and containers, paving the facilities, rainwater, and water that has leaked from the exchangers. Oily water is sent to a separate settling tank where the bottom is scraped to recover any sludge that has thickened and become dehydrated. The sludge is incinerated while the water surface is skimmed to collect any hydrocarbons to send to the slop tanks. The clarified water is sent to the float where coagulation and flocculation agents are used in order to get remaining hydrocarbons to coalesce into corpuscles that will settle. Any sludge on the surface or bottom of the tank is removed and sent to the sludge treatment station (Nabzar and Duplan 2011). Figure 89 shows the average water loss in a typical refinery.

## Average Refinery Water Loss

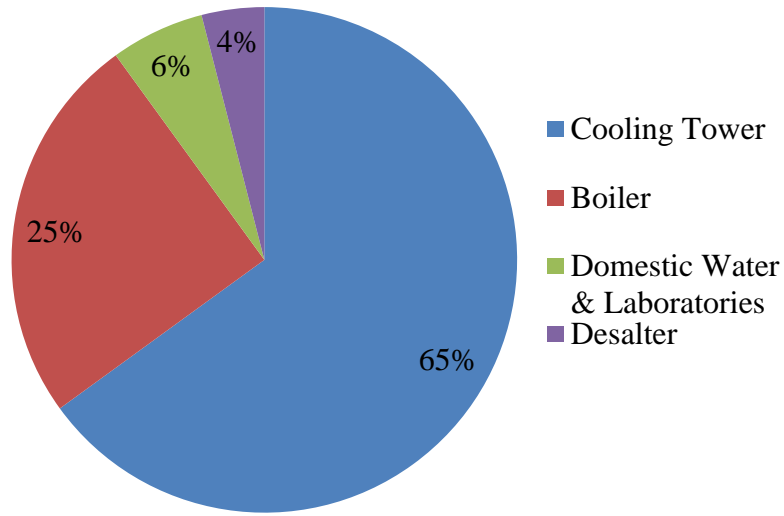

Figure 89. High level view of water loss in a typical refinery (From Nabzar and Duplan 2011).

### *c. Land and Location*

For the efficient production of bio-kerosene to occur, it would be optimal to co-locate a refinery on or near an existing industrial refinement property, such as Tesoro or Chevron, where pipelines and the appropriate infrastructure for transporting fuel and other facilities already exist, also called the hybrid alternative. Dynamic Fuels offer refinement land and location size and scope similarities to the requirements needed, so in an effort to leverage the existing land resources in Hawaii, Dynamic Fuels was the model used in determining the need for acquiring about 25 acres in Campbell Industrial Park or near Barbers Point Harbor (Dynamic Fuels, LLC 2010). This commercial harbor is the second busiest in Hawaii and Kapolei and is one of the fastest growing locations (Bonang 2005). Approximately 12.5 acres is necessary to produce the desired amount of bio-kerosene per year, allowing the remaining 12.5 acres for future growth (Dynamic Fuels, LLC 2010). As industrial lands and locations on the Hawaiian Islands are limited, acquiring industrial land may be challenging. (Bonang 2005). Other lands such as privately held family estates and trusts and state and federal land are unavailable to be purchased for industrial development. Though Native Hawaiian land is already owned by the State of Hawaii, other land that is found or believed to be ancestral land can cause

much undesired controversy with Native Hawaiians and can significantly slow down or stop development. Environmental and permitting issues are also concerns that make acquiring land difficult. Thus, the \$115.5 Million, 188 acre Campbell Industrial Park site, and land near Barbers Point Harbor would be the optimal location to acquire land (Bonang 2005).

Acquiring land in Hawaii is a unique experience that is unparalleled in the United States (Steenwyk 2012). According to Steenwyk, about 236 years ago, Hawaii was a stone-age civilization and just 120 years ago, U.S. Marines and English businessmen forced Hawaii's last monarch, Queen Lili'uokalani, from her throne. The legacy of the Hawaiian monarchy is not only still in existence today, but the Hawaiians have not yet embraced Americans on the mainland or the United States military. The legacy of the monarchy included land and estate trusts held by five main families. To avoid taxes, land was categorized as forest reserve and by 1956, "65% of the 122,000 acres of forest reserve belonged to large private owners like the Bishop and Campbell estates and Castle and Cook" (Cooper and Daws 1990). Though changes and reform have made some improvements, the descendants of the Hawaiian royal family own much of the land in different trusts. Thus, "land is rarely sold outright, in 'fee-simple' transactions" but, are instead 'leasehold' land, accounting for approximately sixty percent of commercial and industrial land transactions as of 2003 (Steenwyk 2012) and (State of Hawaii 2012). As leases do expire, soon hundreds of commercial and industrial businesses will be seeking suitable properties to relocate. (State of Hawaii 2012). This ongoing system of "leasehold ownership frustrates necessary and rational economic development because the leasehold system defies the national trend in industrial and commercial real estate, adversely affects amortization of loans, and deprives ordinary citizens of the privilege of building equity and bequeathing wealth to subsequent generations" (State of Hawaii 2012).

The State of Hawaii owns the majority of the eight main Hawaiian Islands, about 1.52 million acres, with the U.S. Government following closely behind with 531,000 acres. Table 70 lists the land areas of the State of Hawaii and the U.S. Governments land ownership (J. Cooper 2012).

	State of Hawaii	U.S. Government
Native Hawaiian Usage	194,000 acres	Military installations
Hawaii (main island)	Over 1 million acres	Hawaii Volcanoes National Park, military installations
Kauai	156,000 acres	Military installations
Maui	128,000 acres	Haleakala National Park, military installations
Oahu	85,000 acres	Military installations
Lanai	541 acres	8 acres
Niihau	127 acres	271 acres
Kahoolawe	All (except 24 acres)	24 acres

Table 70. Land areas owned by the state of Hawaii and the U.S. Government (After J. Cooper 2012).

When locating land and undertaking construction projects in Hawaii, it is important to consider the possibility of unearthing ancestral land and burial grounds, which may be off limits to development and may cause indignation by Hawaiians. The unearthing of native Hawaiian or ancient bones and artifacts will cause a decision process to begin in coordination with the Historic Preservation Division, Department of Land and Natural Resources. As this division is charged with preserving, managing and maintaining cultural sites and burial sites over 50 years old, along with the construction company, the individual Island Burial Councils work with the division to address issues (Conklin 2007). Either the bones or artifacts will be left in place, potentially inducing a redesign, or moved to allow the project to continue (Conklin 2007) and (Aguiar 2007). Any development project where bones or artifacts are discovered can be shut down abruptly, causing possible cost overruns and delays in completion. When Interstate Highway H1 was constructed diggers found old bones and weapons, causing many delays from excavations and relocation of ancestral artifacts and refusal by native Hawaiians to work the project (Aguiar 2007). Building Interstate Highway H3, which passes through

the Halawa Valley, also caused much controversy and was met with delays because of the valley's religious and cultural significance to Native Hawaiians.

On the Big Island, there is a rainy side, where it rains daily and a dry side with much less precipitation (Lewis 2013). Land on the rainy side is less desirable and thus, can be acquired for a more reasonable price (Jones 2013). From speaking with Mr. Don Jones from Pacific Biodiesel, the cost to acquire land to build the Pacific Biodiesel facility on one acre of land in Hilo's industrial Park was \$600,000. This was the least expensive land per industrial acre, found at the time, since it was located on the rainy side of the island (Jones 2013).

Environmental concerns and build permitting difficulties are additional issues to consider when building a refinery. Since 1976, no new standalone commercial oil-refining plants have been built in the U.S. (Conklin 2007). As was done with Dynamic Fuels, it is less expensive to expand production than to construct new plants and supporting infrastructure (U.S. Energy Information Administration 2008) and (Conklin 2007). While 325 oil refineries existed in the U.S. in 1981, only 149 remain today because the government subsidized the existence of small, inefficient refineries (Conklin 2007). As technology and the refining process improved, the operational efficiency of oil refineries increased allowing refineries to operate closer to their capacity (U.S. Energy Information Administration 2008) and (Conklin 2007). Today's more competitive and globalized fuel market yields a more diversified supply and makes the U.S. market less vulnerable to disruption. On average, petroleum accounts for about 37.5% of the total energy consumption in the United States. Hawaii's total energy consumption is far greater, utilizing petroleum for 85% of its total energy needs. As Hawaii has such a high need for petroleum, more than double that of the mainland, Hawaii's petroleum dependency highlighted the need to become more energy independent. Since Hawaii is logistically the most vulnerable location in the nation to interference in the world oil markets, it requires a strategically sound local and renewable fuel source (State of Hawaii Department of Business 2011). On January 8, 2013, Hawaii News Now reported that the Tesoro refinery will close in April due to Hawaii's challenging business environment (Daysog 2013). This shutdown may present an opportunity to purchase and co-locate a

hybrid refinery on industrial land, thereby reducing Hawaii’s vulnerability to disturbances in the world market.

*d. Manpower*

The amount of manpower required to operate and maintain an oil refinery is largely dependent on two factors: crude oil throughput and complexity. In general, increased crude oil throughput and increased complexity leads to an increased amount of manpower. Figure 90 is a comparison of the throughput of current operating refineries and the total number of full-time employees operating and maintaining them.

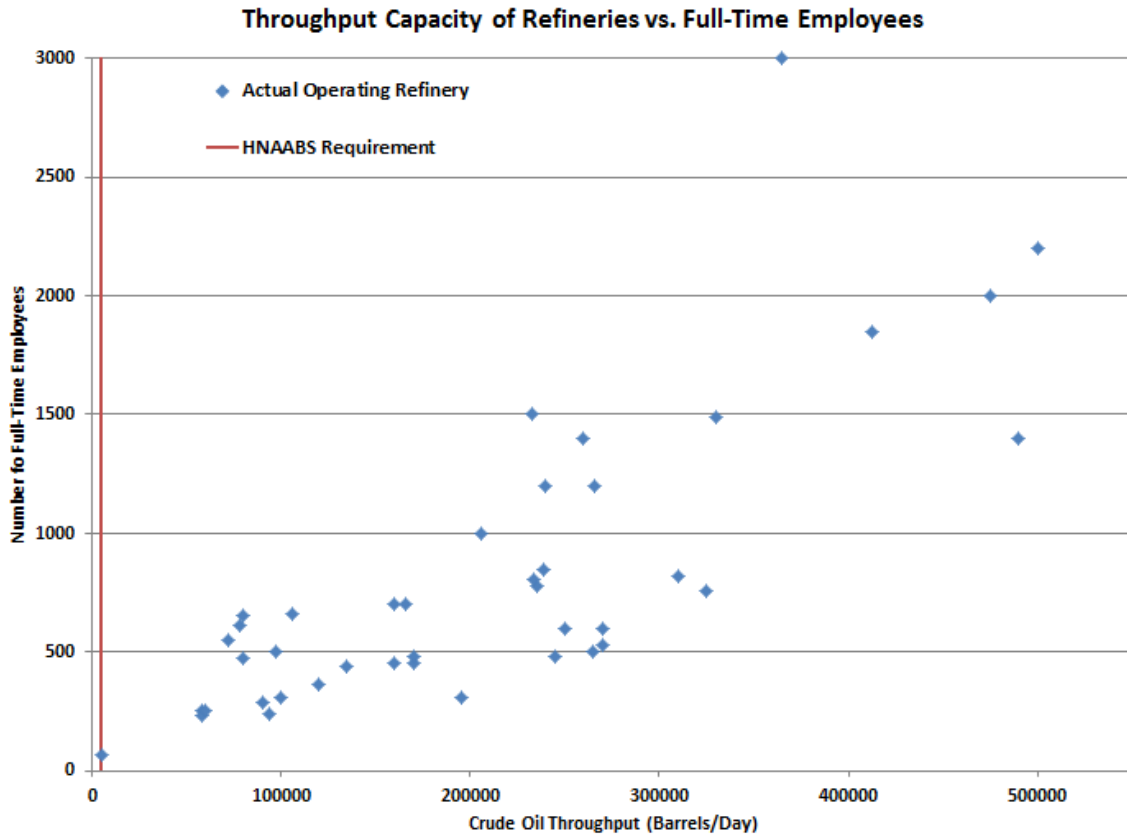

Figure 90. Oil refinery throughput compared to the number of full-time employees (Data compiled from oil refining company websites by the HNAABS Team).

Figure 90 was generated by the HNAABS Project Team and contains data compiled from over 40 different refineries around the world, with a majority of the

refineries located in the United States. These refineries are owned and operated by one of the following major oil refinement companies: British Petroleum (BP), Chevron, Dynamic Fuels LLC, Exxon Mobil, Marathon, Phillips 66, Tesoro, or Valero. All data was sourced from each refineries respective company website.

Figure 90 supports the trend that as refinery throughput increases so does the manpower requirement, up to a threshold. At approximately 200k bbl/day throughput manpower begins to be affected by the refinery throughput. At less the 200k bbl/day throughput there is a wide variance in the data and the number of employees appeared to be independent from the throughput. Figure 91 shows a subset of the data that contains only refineries with a throughput of less than 200k bbl/day.

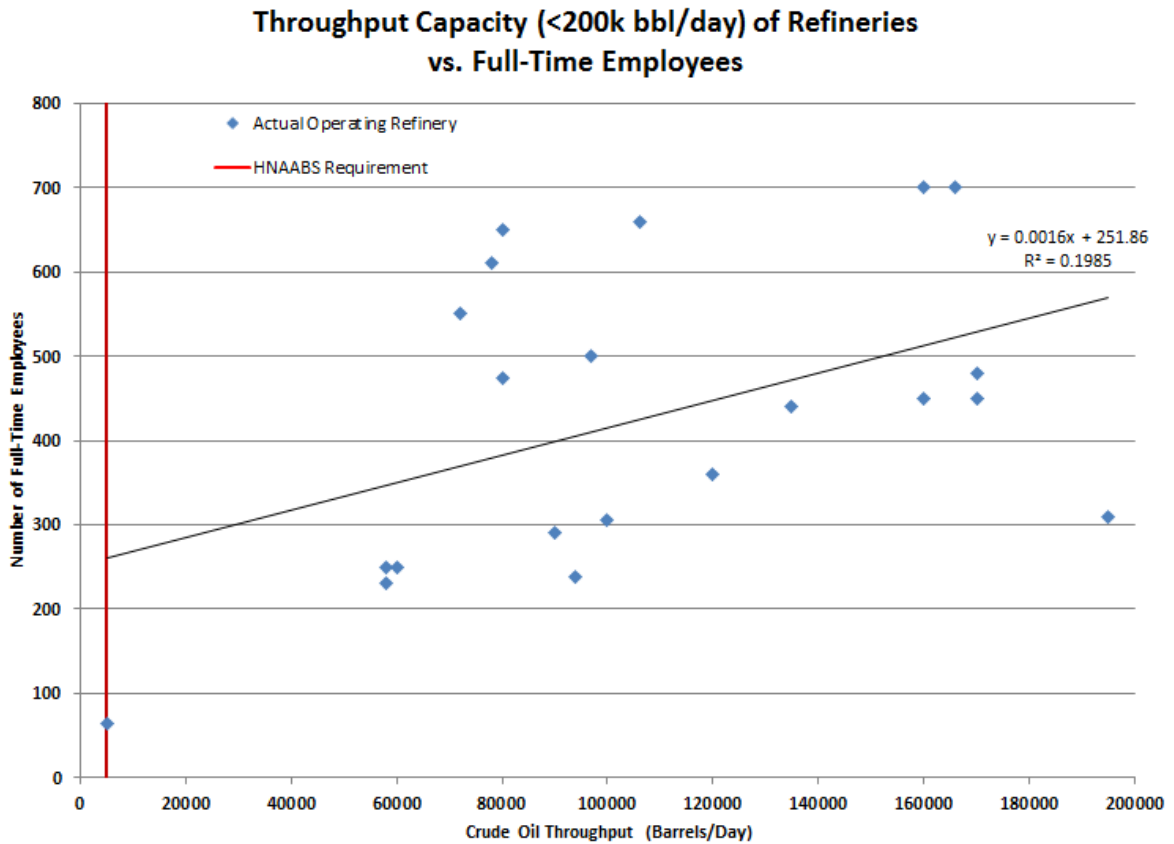

Figure 91. Oil refinery throughput (<200k bbl/day) compared to full-time employees.

Figure 91 was generated by the HNAABS Project Team and shows a wide distribution of full-time employees that does not follow the same trend as it does with

higher (>200k bbl/day) throughput refineries. The trend line in the figure above suggests that the number of employees marginally increases with throughput. The  $R^2$  value of 0.1985 suggests inconsistency and unpredictability of the number of full-time employees at refineries with lower throughputs. There is very little correlation between the number of employees and refineries with lower throughputs. The HNAABS refinery is estimated to fall into this category of lower throughput refineries. The redline in Figures 90 and Figure 91 represents the system objective throughput requirement of the HNAABS refinement system, which falls well below the 200k bbl/day threshold.

The varying complexity of the refineries contributes to the inconsistencies seen in the number of employees. Some refineries require extensive ‘second stage’ processing that allows them to use lower quality crude oil and still produce high quality products. This greatly increases a refineries complexity, but allows for more flexible inputs and the ability to buy cheaper crude oil, saving money and increasing profits.

The HNAABS refinery’s manpower requirement is most closely compared with the Dynamic Fuels refinery, which has a throughput of 5k bbl/day and approximately 65 full-time employees (Dynamic Fuels, LLC 2010). Thus, the HNAABS Project Team chose to ignore the significantly high intercept value (approximately 260) of the trend-line and HNAABS throughput in Figure 91 due to the large variance of the projection model. Comparing the HNAABS refinement system complexity to the Dynamic Fuels refinery, the HNAABS has increased ‘second stage’ complexity. Because manpower is more likely related to system complexity than throughput for very small levels, the average percent difference from each data point to the linear trend line was used to generate a manpower estimate. This average difference is 34%. Because the HNAABS is more complex than the Dynamic Fuels facility, the 65 full time employees of Dynamic Fuels was used as a minimum. The average refinery manpower variance of 34% was then used to calculate the maximum, resulting in a manpower estimate between 65 and 88 full-time personnel for the HNAABS refinement system.

## **6. By-Product Stream Analysis**

A by-product stream analysis was performed to address major environmental concerns related to the refinement of green crude. Since refinement of green crude is a cleaner process than that of petroleum and since existing refineries currently reside in Hawaii and abide by the environmental rules and regulations set forth by Hawaii, all aspects and processes of by-product management will not be addressed. This stream analysis did however identify possible by-products, hazardous materials, process water treatments, sludge treatments, carbon capture and storage/sequestration (CCS), hydrogen recovery and purification, and the quantity of by-products produced by Tesoro and Chevron. Petroleum crude by-products served as the baseline. Due to the different types of green crudes and the composition differences, it is difficult to predict the type and quantity of the by-products.

### ***a. By-products.***

The petroleum crude by-products baseline was adjusted based on the knowledge of green crude types and refinement processes. Table 71 lists the petroleum by-products for crude processed in a refinery (World Bank Group 1998).

<b>By-Product</b>	<b>Average</b>	<b>Range</b>
Particular Matter	0.8 kg/t	0.1 to 3 kg/t
Sulfur Oxides	1.3 kg/t (0.1 kg/t with the Claus sulfur recovery process)	0.2 to 6.0 kg/t
Nitrogen Oxides	0.3 kg/t	0.06 to 0.5 kg/t
Benzene, Toluene, and Xylene (BTX)	2.5 g/t (1 g/t with the Claus sulfur recovery process) 0.14 g/t Benzene, 0.55 g/t Toluene, 1.8 g/t Xylene	0.75 to 6 g/t
VOC Emissions	1 kg/t	0.5 to 6 kg/t
Wastewater (for cooling systems, surface water runoff, sanitary)		3.5 to 5 m <sup>3</sup> when cooling water is recycled
Biochemical Oxygen Demand (BOD)		150 to 250 mg/l
Chemical Oxygen Demand (COD)		300 to 600 mg/l
Phenol		20 to 200 mg/l
Oil		100 to 300 mg/l in desalter water and up to 5,000 mg/l in tank bottoms
Benzene		1 to 100 mg/l
Benzocac Pyrene		Less than 1 to 100 mg/l
Heavy Metals		0.1 to 100 mg/l Chrome, 0.2 to 10 mg/l Lead
Solid Wastes and Sludges		3 to 5 kg/t, 80% of which may be considered hazardous because of the presence of toxic organics and heavy metals

Table 71. Petroleum by-products for crude processed in a refinery (After World Bank 1998).

Green crude refinement by-products vary slightly from what is listed in Table 71 for petroleum crude since green crude by-products have fewer sulfur oxides and Benzene, Toluene, and Xylene (BTX) and more nitrogen than petroleum crude by-products. BTX is usually produced during the catalytic reforming of crude oil, which is not part of the system functional architecture to produce jet fuel from green crude. Therefore, BTX by-products will not be considered in this stream analysis. The presence of sulfur and heavy metals in green crude is negligible so sulfur, hydrogen sulfide, sulfur dioxide and heavy metal by-products were not considered in the steam analysis as well. Green crude has a significantly higher amount of nitrogen than petroleum crude. This

could increase the amount of nitrogen dioxide released either during refinement or fuel combustion depending on the amount removed during HDN and hydrocracking (Food and Agriculture Organization of the United Nations 1997). The refinement of green crude relies heavily on the Deoxygenation process. Deoxygenation consists of the following reactions: decarboxylation, decarbonylation and hydrogenation. These reactions require release by-products of CO, CO<sub>2</sub> and H<sub>2</sub>O, which could increase the quantity shown in Table 71 for those by-products. The processes and standards for how to treat, recycle and/or dispose of green crude refinement by-products are explained in the following five sections.

***b. EPA Hazardous Wastes and Land Disposal Restrictions (LDR) Treatment Standards.***

The HNAABS will need to abide by the EPA treatment standards for hazardous wastes or by-products and LDR as listed for petroleum refining. For hazardous wastes or by-products for petroleum refining, see EPA's 40 CFR 261.32 (U.S. Environmental Protection Agency 2013).

There are two categories of ignitable by-products: (1) By-products with greater than or equal to ten percent total organic carbon and (2) all other ignitable by-products. Under the LDR program, treatment standards for ignitable by-products are combustion, recovery of organics, polymerization or removal of ignitability characteristics by deactivation, and treatment of underlying hazardous constituents to meet treatment standards. Characteristics of toxic by-products include metals, pesticides and organics. The EPA states, "most toxic by-products must be treated to a specific numerical standard for underlying hazardous constituents" (U.S. Environmental Protection Agency 2001, 28-31). The applicability of the specific numerical treatment standards, as listed in 40 CFR 268.40, is shown in Appendix E.

***c. Process Water Treatment.***

Process Water is water used during the production and refinement of green crude that is added separately. Water uses in a typical petroleum crude refinery are as follows:

- Process water
  - Desalter makeup
  - Coker quench water
  - Coker cutting water
  - Flare seal drum
  - Fluid catalytic cracking scrubbers
  - Hydrotreaters
- Boiler feedwater makeup
- Cooling water makeup
- Fire water
- Utility water

The largest water uses are the process water, boiler feedwater makeup, and cooling tower makeup. These are ideal candidates for using recycled water. Table 72 shows how treated water can be recycled back into a typical petroleum crude refinery (IPIECA 2010, 42).

<b>Water Source</b>	<b>Potential Application of Re-use Water</b>
Desalter makeup	Stripped sour water
Coker quench water	Stripped sour water
Coker cutting water	Stripped sour water
Boiler feedwater makeup	Treated and upgraded refinery process water
Cooling tower makeup	Treated and upgraded refinery process water
Fire water	Non-contaminated stormwater

Table 72. Process water re-use (After IPIECA 2010, 42).

Processing of HNAABS refinement Process Water will allow for by-product separation and removal, as well as Process Water reuse back into the refinery. The International Petroleum Industry Environmental Conservation Association (IPIECA) has identified best practices for petroleum refining Process Water use and management that HNAABS will follow.

Process Water treatment begins once water is used, collected, and fed into the Process Water treatment facility. Figure 92 shows how typical refinery process water

is treated with primary and secondary oil/water separation, a biological treatment, and an optional tertiary treatment (IPIECA 2010, 25).

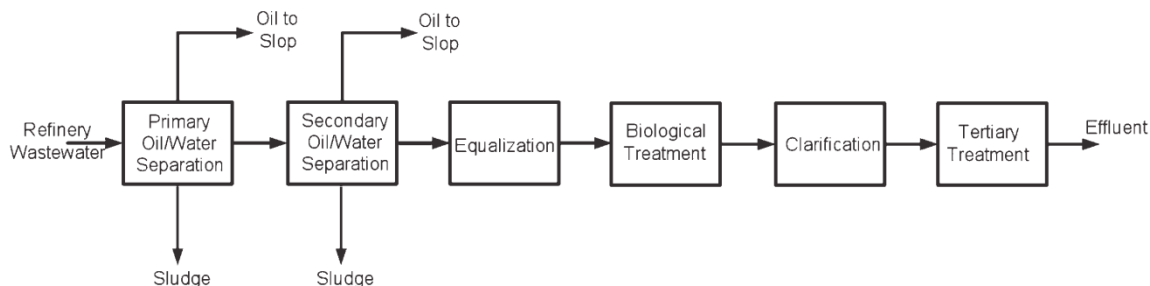

Figure 92. Typical refinery process water treatment (From IPIECA 2010, 25).

An API separator, primary oil/water separator, removes oil from the process water followed by a DAF or IAF unit, secondary oil/water separator. Once the process water is separated from the oil, it is sent through equalization, biological treatment, clarification, and tertiary treatment. A tertiary treatment is used process contaminants such as the total suspended solids (TSS), chemical oxygen demand (COD), dissolved and suspended metals, and trace organics such as polyaromatic hydrocarbons (PAHs) (IPIECA 2010, 25-38) Once process water has been treated, it can be re-used.

New technologies for Process Water treatment utilize one or more filtration processes. These technologies currently are not widely used; however, the refining industry is starting to look at these options as water costs increase. With the incorporation of these technologies, HNAABS would be better equipped to process and recycle additional used water from the refinery. Table 73 shows a list of available technologies and their suitability for water re-use (IPIECA 2010, 50-51).

Technology	Suitability
Media filtration	Removes suspended solids but not dissolved solids. Treated water not suitable for cooling water or boiler feedwater makeup but can be used for other uses such as utility water or fire water.
Ultrafiltration or microfiltration	Removes suspended solids (to a greater extent than media filtration) but not dissolved solids. Treated water not suitable for cooling water or boiler feedwater makeup but can be used for other uses such as utility water or fire water.
Ultrafiltration or microfiltration, with reverse osmosis	Removes both suspended and dissolved solids. Treated water suitable for all uses in the refinery including cooling tower and boiler feedwater makeup
Ultrafiltration or microfiltration, with nanofiltration	Removes both suspended and dissolved solids. Treated water suitable for all uses in the refinery including cooling tower and boiler feedwater makeup. Salt rejection is lower than reverse osmosis but this system can be operated at a lower pressure than RO systems
Ion exchange	Removes both suspended and dissolved solids. Treated water suitable for all uses in the refinery including cooling tower and boiler feedwater makeup. Usually applicable when the dissolved solids concentration is less than 400 mg/l.

Table 73. Process water treatment system upgrades (From IPIECA 2010, 50).

*d. Sludge Treatment.*

During process water treatment, sludge is separated from the process water, collected, and fed into the appropriate treatment system. Figure 93 shows how bottom sludge retrieved from the API separator will be treated. Sludge will be disposed off-site (IPIECA 2010, 40).

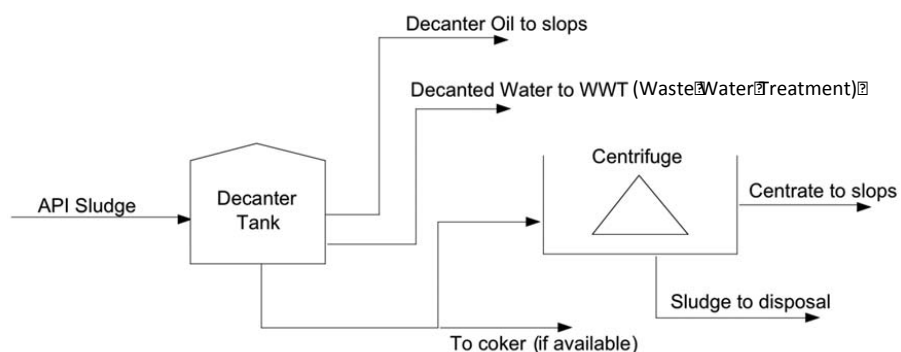

Figure 93. API sludge treatment system (After IPIECA 2010, 40).

Chemicals added in separation create emulsions in the float from the DGF and IGF. As a result, DGF/IGF float is treated separately as shown in Figure 94. By-products from the tank are disposed of off-site.

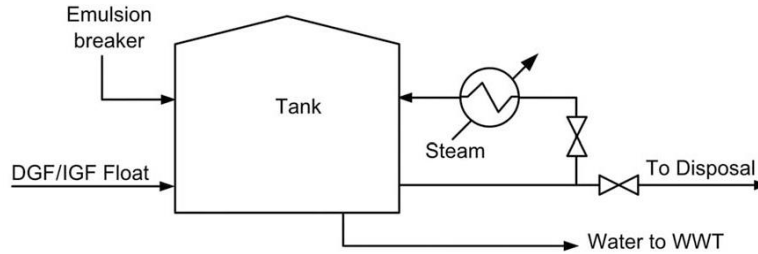

Figure 94. DGF/IGF float treatment system (From IPIECA 2010, 41).

The DGF sludge goes to the API sludge treatment system as shown above in Figure 93 (IPIECA 2010, 40). Biological sludge is pre-treated using the system shown in Figure 95. Disposal of biological sludge depends on local Hawaii regulations on land farming, landfills, and off-site disposal as specified by Hawaii Administrative Rules, Title 11, Department of Health, Chapter 58.1, Solid Waste Management Control (IPIECA 2010, 41).

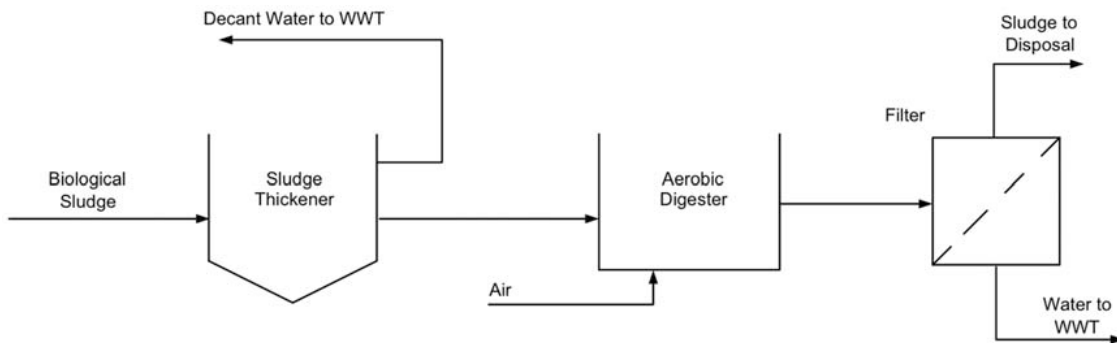

Figure 95. Biological sludge treatment system (From IPIECA 2010, 41).

*e. Carbon Capture and Storage/Sequestration (CCS).*

Refineries have begun investigating CCS as a viable method of reducing CO<sub>2</sub> emissions. CO<sub>2</sub> is captured, compressed, dried and transported to a storage location. CO<sub>2</sub> is then used for green crude production, and other applications. Since CO<sub>2</sub> is used in the production of green crude, it would be beneficial to co-locate the HNAABS

cultivation and refinement systems in order to maximize efficiency and reduce transportation and storage costs of the CO<sub>2</sub>. There are three kinds of CCS: pre-combustion, post combustion, and oxyfuel combustion capture (Stockle 2012). Since the post-combustion process is the simplest and can be installed into existing and new refineries and combined with almost any type of combustion system. This process is recommended for the HNAABS refinery. The post-combustion process uses a cooler, blower and absorber located near each source. The cooler uses direct water contact before the combustion flue gas enters the blower. The blower is designed to overcome the pressure drop of the absorption system. In the absorption column, the flue gas is washed with a physical solvent like monethanolamine. From there, scrubbing eliminates as much as 90 percent of the CO<sub>2</sub> content from the flue gas. The flue gas then returns to the combustor stack where it is released to the atmosphere. The CO<sub>2</sub>-rich solvent is heated against lean solvent and regenerated in a stripping column. After which, the solvent returns to the absorption column, and the released CO<sub>2</sub> is dried and compressed to later be exported (Stockle 2012).

*f. Hydrogen Recovery and Purification.*

Hydrogen is an important component in refining green crude. Within a refinery, Polybed Pressure Swing Absorption (PSA) and Polysep Membrane systems can be used to recover and purify hydrogen from the steam reforming (hydrogen plants), hydrocracker and hydrotreater purge gases, and hydrocracker flash gas. The cyclical UOP Polybed PSA System absorbs impurities in a hydrogen containing steam at high pressure and rejects them at low pressure. The resulting hydrogen is slightly below the feed pressure. It is typically upgraded to 99.9+% purity and can be recovered at a rate of 60% to over 90%. Figure 96 shows the Polybed PSA flow scheme (UOP, A Honeywell Company 2011).

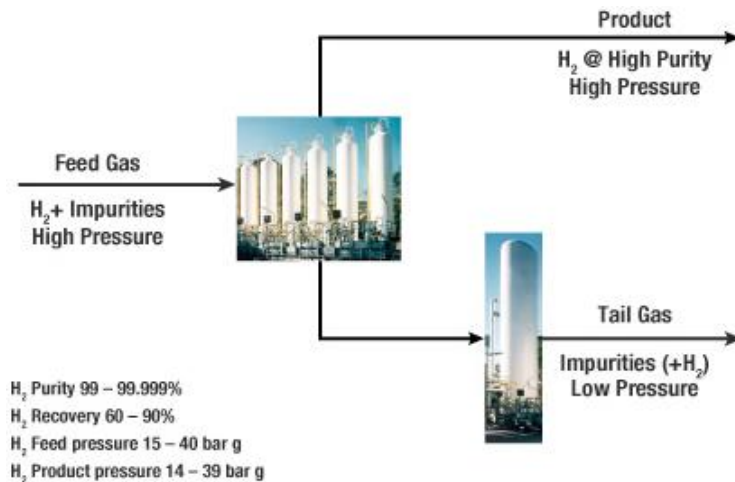

Figure 96. Polybed PSA system flow scheme (From UOP, A Honeywell Company 2011).

The membrane process uses the Polysep Membrane System, for high pressure purge gas upgrading. The Polysep Membrane System uses a polymeric membrane to separate gas mixtures by their different permeation rates. This is a high feed, continuous pressure driven process. The system normally produces hydrogen at 300-600 psig with 92-98 vol-% purity and a hydrogen recovery rate of 85-95%. Figure 97 shows the Polysep Membrane System flow scheme. (UOP, A Honeywell Company 2011)

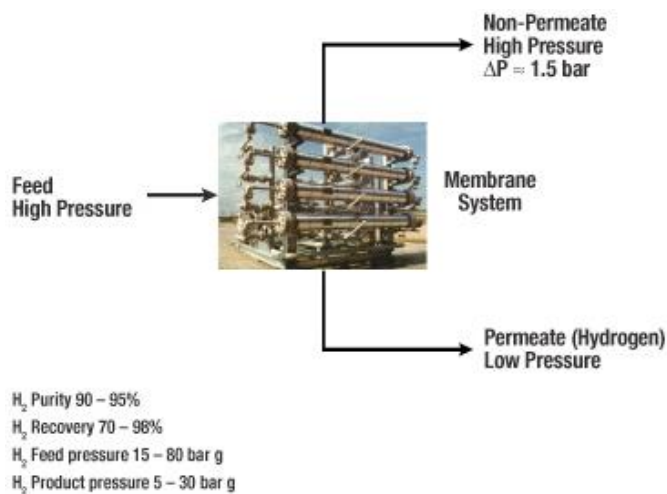

Figure 97. Polysep membrane system flow scheme (From UOP, A Honeywell Company 2011).

**g. Tesoro and Chevron By-Product Quantities.**

The HNAABS Project Team looked into by-product outputs of existing refineries to determine the possible by-product output for the HNAABS refinery. Data obtained from the U.S. EPA’s Toxic Release Inventory database reveals the by-product quantities Tesoro and Chevron, two existing refineries in Hawaii, have produced in 2005 and 2007, respectively (U.S. Environmental Protection Agency 2012). They are compared in Figure 98.

**Tesoro Hawaii Refinery By-Product Outputs**  
Totals (lbs) for this search for 2005

By-product quantities-	
Recycling on-site	898.5
Recycling off-site	17,638.78
Burning for energy recovery off-site	150.7
Treatment on-site	4,336.70
Other release onsite	130,957.20
RCRA landfill disposal offsite	14,110.60
Other disposal offsite	8.5
Total Production-related By-products	168,100.98
Non-production-related By-products	0
Form A Midpoint By-products	250
Total By-product	168,350.98

Tesoro: 89,135 barrels/day = 32,534,275 barrels/yr  
By-product per barrel (lbs) 0.01

**Chevron Hawaii Refinery By-Product Outputs**  
Totals (lbs) for this search for 2007

By-product quantities-	
Treatment on-site	496,230
Treatment off-site	351
Other release onsite	276,051.10
RCRA landfill disposal offsite	1,019
Other disposal offsite	195
Total Production-related By-products	773,846.10
Non-production-related By-products	0
Form A Midpoint By-products	0
Total By-product	773,846.10

Chevron: 60,000 barrels/day = 21,900,000 barrels/yr  
By-product per barrel (lbs) 0.03533544

**Figure 98. Tesoro and Chevron by-product quantities (After U.S. Environmental Protection Agency 2012 and Hawaii Foreign-Trade Zone 2013).**

The Tesoro refinery produced fewer by-products per barrel in 2005 than Chevron did in 2007. This is most likely due to Tesoro’s efforts in recycling and treatment of its by-products produced during refinement of the crude. Given this information, the HNAABS Project Team has concluded that the HNAABS refinery could produce between 0.01 and 0.035 pounds of by-products per barrel of green crude refined. HNAABS refinery will manage by-products similar to that of existing refineries in Hawaii, as well as through process water treatments, sludge treatments, carbon capture and storage/sequestration (CCS), and hydrogen recovery and purification.

## 7. System Alternatives Analysis

Three alternatives were considered by the HNAABS Project Team for implementation of HNAABS Refinement system concept described in the previous sections. This section describes the benefits and drawbacks of each alternative:

- Retrofit a petroleum crude refinery
- Build a new standalone green crude refinery
- Construct a green crude refinery onsite to an existing petroleum refinery (hybrid)

### *a. Retrofitting a Petroleum Refinery*

This section discusses the option of taking an existing petroleum refinery in the state of Hawaii and modifying it to accept green crude as a feedstock. When considering an existing refinery, there are three options to consider that will be discussed in this section:

- Co-processing green crude with petroleum
- Converting to green crude only
- Blocked out operation

(1) **Co-Processing Green Crude.** Co-processing green crude with petroleum would require pretreating the green crude prior to mixing with petroleum feedstock. Pretreatment would deoxygenate the oil and convert the fatty acids and triglycerides to alkanes that are in the diesel range of straight chain paraffin (Carlson, et al. 2010). The deoxygenated oil feeds into the normal refinement processes with the petroleum crude where it undergoes hydrocracking and separation into jet fuel and diesel range fractions. This approach would have a low initial capital cost, relying heavily on existing equipment and processes. The only required addition would be a green crude pretreatment unit, which comes with significant technical challenges due to green crude's characteristics. Green crude pretreatment could produce large amounts of water (H<sub>2</sub>O), carbon dioxide (CO<sub>2</sub>), and carbon monoxide (CO) while requiring large amounts of

hydrogen (Carlson, et al. 2010). This would affect the hydrogen production and utilization of the refinery and put constraints on the hydraulic capacity of the equipment, which would limit the amount of oil processed. The additional levels of CO<sub>2</sub> and CO are a consideration in choosing between a recycle-gas system for removal, or substantial purge stream (Holmgren 2007). In addition, contaminants contained in the oil could have a significant impact on the efficiency and life of the catalysts used.

Co-processing oils was not found to be economically favorable. The significant difference in the chemical makeup of the two oils does not allow for optimization of either, resulting in either excess oxygen or sulfur in the fuel since the deoxygenation of green crude competes with the primary desulfurization reactions required by the petroleum crude (Holmgren 2007).

The military is working on the development of specifications for jet fuel derived from green crude. However, this process of producing jet fuel would not meet the current specification for aviation fuels for civil use as specified in ASTM D1655. The use of synthesized hydrocarbons from sources such as algae is outside the scope of ASTM D1655 and is governed by ASTM D7566. Once certified by ASTM D7566, the jet fuel can be blended in a 50/50 ratio with petroleum derived jet fuel and certified under ASTM D1655.

(2) **Conversion of Refinery.** The conversion of current refineries in Hawaii would not be advantageous from a technical or cost standpoint. The Tesoro and Chevron refineries are both large refineries that have a far higher throughput than the producible amount from the green crude provided. Chevron's facility, the smaller of the two, does not own or operate a hydrocracking unit, which is a key requirement for the production of jet fuel from green crude. Due to the much smaller variance in hydrocarbon chain lengths when compared to petroleum, many of the current systems at the refinery would go unused and many of the major products would likely be unproduced. The refinery would require significant modifications to handle the problems from green crude's characteristics. Necessary modifications could include metallurgy upgrades, by-product handling modifications, and installation of green crude pretreatment units or modifications to the distillation tower (Earl and Bhagat 2010).

(3) **Blocked out Operation.** Oil refineries often have blocked out operations of different processing units to optimize costs when accounting for seasonal fluctuations of crude oil characteristics and requirements of various fuel products (UOP LLC, A Honeywell Company 2013). It is not optimal or economical to operate with the same output levels year round due to changing demands. Blocking out operations of a facility's hydrocracking unit could allow for processing of both petroleum and green crude without the concerns of co-processing the two at the same time. Pretreatment of green crude would occur in a new unit that would feed the existing hydrocracking unit at different times than the petroleum crude. The implementation costs are reduced while allowing for separate processing of the two oils.

Since Tesoro is the only refinery in Hawaii with hydrocracking capability, blocked out operations would have to be conducted in coordination with petroleum refinement. A DARPA study conducted at the Tesoro Refinery analyzed multiple biofuel refinement implementation alternatives, including a blocked out operations alternative. The details of the study are proprietary to both the Tesoro Corporation and UOP LLC and the results of the study are only releasable with the permission of both companies.

***b. Building a New Green Crude Refinery in Hawaii***

Building a brand new oil refinery in Hawaii dedicated to the refinement of green crude and other bio-oils is another alternative that satisfies the requirements of stakeholders.

A major advantage of this option is the flexibility and options within the system design, architecture, and infrastructure. Contrary to retrofitting an existing petroleum refinery, the ability to start from the ground up opens up many more possibilities for the system designer to satisfy the stakeholder's requirements. There is no consideration of existing infrastructure constraint and fewer integration and interfacing issues. When building a new refinery, the system designer and stakeholders are not immediately disadvantaged with significant integration and interfacing issues. Instead, the system design phase optimizes the system interfaces.

Furthermore, building a new refinery allows HNAABS to use the most current technology and materials. A significant amount of advancement in technology and green crude processing has occurred since the construction of the Chevron and Tesoro refineries in 1962 and 1970, respectively (University of Hawai'i Economic Research Organization 2013). For example, a new refinery can incorporate materials that resist corrosion and are compatible with green crudes to increase the reliability of the system. Several processes have also been developed and proven to produce effective bio-jet fuel that, in some cases, satisfies DoD fuel standards (UOP LLC, A Honeywell Company 2012) (Brown 2009). Due to the competitive nature of the industry, details of these processes are proprietary to their respective companies. For example, Bio-Synfining™, developed by Syntroleum®, is the process utilized by the Dynamic Fuels refinery (Biofuels Journal 2008). A new refinery could incorporate these processes and technologies more easily than a retrofitting an existing one. Though a lot of green crude refinement processes are proprietary, the HNAABS Team conducted a thorough amount of research and developed a system description that includes the functions (Section II.B.3) and physical components (Section II.C.3) necessary to implement and/or build a green crude refinery.

A new refinery would also create a significant amount of jobs in Hawaii. Building a new refinery is a large construction project requiring multi-disciplined manpower. The Dynamic Fuels refinery's construction between 2008 and 2010 projected an employment of approximately 250 full-time workers (Biofuels Journal 2008). Since the HNAABS and Dynamic Fuels refinery are of similar size and function, constructing a new algal-oil refinery in Hawaii should create a comparable number of jobs.

Major drawbacks of building a new refinery, however, include implementing and creating the external system interfaces that exist within an established refinery. Some external interfaces include transportation (crude, finished product, by-product, etc.) and other resources (hydrogen supply, water supply, etc.). The existing refineries have established all of these interfaces and infrastructures. The Tesoro Refinery has pipelines connecting directly to the Honolulu International Airport, military installations, and Kalaeloa Barbers Point Harbor (for access to ships and barges) (Tesoro

Corporation 2012). Refineries require a significant amount of external interfaces and infrastructures to operate, which will lead to a significant amount of costs not incurred when retrofitting a refinery.

Another drawback is the limited amount of land suitable for industrial use. Hawaii's land area is one of the smallest in the country. The State of Hawaii is very protective of its land. There are many areas considered sacred and protected from development aside from state and national parks. This leaves little land for a new green crude refinery. During the September 2012 visit to Hawaii, multiple stakeholders emphasized the lack of land availability. Section III.C.5.c, Land and Location, details the land and refinery locations.

There are significant costs associated with building a new refinery. The new refinery needs infrastructure connections, where an existing refinery would not incur this cost. The Dynamic Fuels refinery cost approximately \$170 Million (Dynamic Fuels, LLC 2010). Hawaii's land and resources, however, are much more expensive than Louisiana, which is also a 'hot-bed' for oil refinement. Dynamic Fuels chose to locate its facility in Louisiana based on the proximity to oil refinement resources (Dynamic Fuels, LLC 2010). Similar infrastructure exists in Hawaii, but at a significantly smaller magnitude. Considering cost of living, Kapolei, Hawaii (Tesoro) is 68% more expensive than Geismar, Louisiana (Dynamic Fuels, LLC 2010) (Sperling's BestPlaces 2013). Salaries and construction costs are affected by this difference. Applying the cost of living difference to the facility cost from Louisiana to the cost of the same facility in Hawaii, the Hawaii refinery would cost \$285.6 Million. Thus, the Hawaii refinery costs an extra \$115.6 Million to build. The significant building costs in Hawaii are an important consideration in building a refinery.

*c. Hybrid Alternative*

Initially, only two options were considered, retrofit an existing petroleum refinery or build a new green crude refinery. To maximize the benefits of each option, a hybrid alternative was considered.

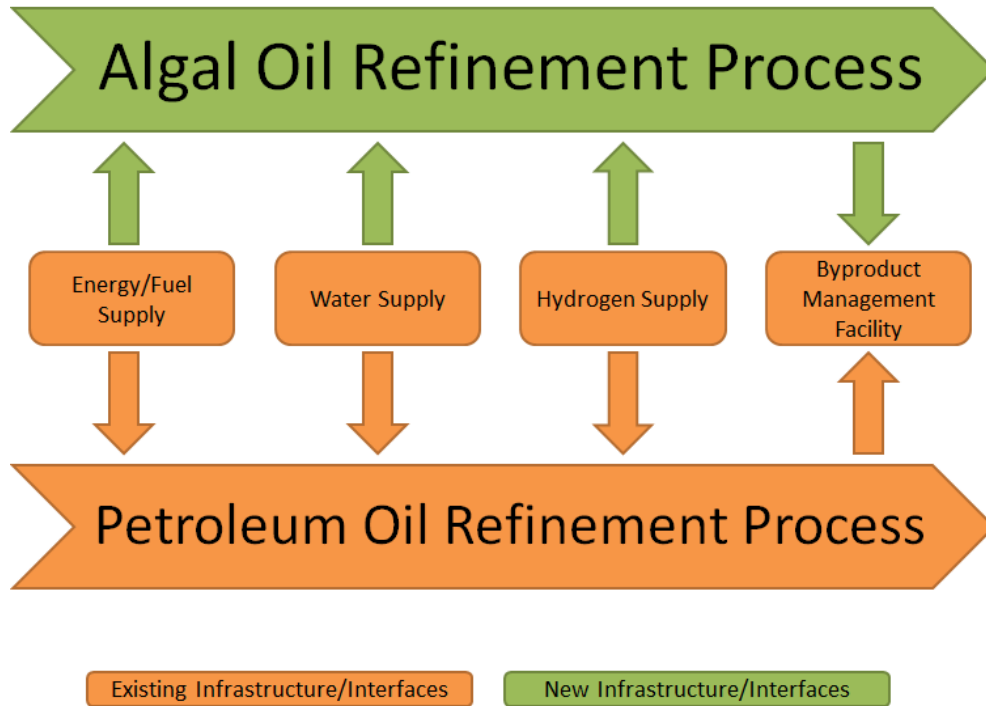

Figure 99. System architecture for hybrid refinery alternative.

Figure 99 depicts the hybrid alternative in which both petroleum and green crude products have parallel production. The hybrid alternative calls for the building of a new green crude refinery in close proximity to a current petroleum refinery so they can share primary resource supplies and a by-product management facility. In Figure 1, the orange represents existing petroleum infrastructure and interfaces and the green represents the new infrastructure and interfaces that would need to be procured and developed for green crude refinement.

The hybrid alternative has additional benefits and increased capabilities over the other previously discussed alternatives. The hybrid alternative is capable of producing petroleum and bio-fuel products in parallel, instead of a singular product. Maintaining the capability to produce petroleum is significant because most combustion engines currently rely on petroleum-based fuels. Also, a hybrid system that is producing both petroleum fuels and biofuels in parallel would require additional manpower, creating more full-time jobs. Details regarding manpower for the green crude refinement portion of the hybrid system are available in Section III.C.5.d.

The previously mentioned DARPA study conducted at the Tesoro Refinery, also investigated and analyzed an alternative similar to the hybrid option. While details of the study are proprietary to both the Tesoro Corporation and UPO LLC, the high-level functions and major system components are aligned with those of the HNAABS refinement system functions (Section II.B.3) and physical components (Section II.C.4). Section II.B.3 and Section II.C.3, and the HNAABS CORE<sup>®</sup> file attached to this report, describe, in detail, the functions and components necessary to implement a parallel green crude refinement process. It should be noted that the system concept described in the aforementioned sections and attachment was designed to be inclusive of all three alternatives (retrofit, build new, or hybrid).

A hybrid alternative could potentially increase the capability to blend bio-fuel and petroleum fuel on-site. The capability to blend fuel is not within the scope of HNAABS or this report but is being pursued and addressed in by the NAVSEA Capstone team mentioned previously. The hybrid alternative could be applied to any existing petroleum refinery with a resource supply infrastructure and by-product management facility that would satisfy the HNAABS requirements. DARPA already studied Tesoro as a potential for a hybrid site. A similar study should be performed on the Chevron refinery to allow for a direct comparison of the two facilities. The lack of a hydrocracking unit at Chevron should not be a negative factor, as this hybrid system would call for the installation of a complete green crude refinement system, including a hydrocracker, adjacent to the petroleum refinement system.

Based on the thorough amount of research and analysis conducted by the HNAABS Project Team, it was concluded that the lowest risk alternative for implementing a bio-oil refinery in Hawaii is the hybrid alternative capable of producing both bio-kerosene and petroleum fuels.

## **8. Results and Recommendations**

The HNAABS refinement system offered a high-level system concept for a green crude refinement system and an analysis of alternatives for implementing this system in Hawaii.

Based on the information and analysis conducted by the HNAABS Team, the team concluded that the lowest risk and most cost effective alternative for implementing a green crude refinery in Hawaii is the hybrid alternative. The hybrid alternative offers the greatest return on investment. It has an increased capability of producing petroleum fuels in parallel with bio-kerosene (and other biofuels). Thus, the biofuel path can be tailored to fit the stakeholders' requirements. The retrofitting option only allowed for the production of bio-kerosene, or petroleum at a single time, and was highly constrained to the existing petroleum refinery infrastructure. Retrofitting a petroleum refinery to refine green crude also yielded a lower reliability of system components due to green crude incompatibility. Green crude contains higher oxygen concentrations, which cause corrosion, thermal instability, and chemical instability. Building a new refinery requires the construction of external infrastructure and interfaces to support the facility (supplies for hydrogen, water, energy; product transportation pipelines; unwanted by-product disposal infrastructure; etc.). A significant amount of indirect costs are incurred when constructing a new facility. The hybrid system alternative combines the benefits of both the retrofit and new build alternatives while providing an increased system capability.

The high-level system concept described in this section was designed to satisfy the stakeholder's needs and derived system requirements. It can be utilized by any of the three system implementation alternatives. The high-level system concept calls for three primary refinement functions in the following order: Hydrotreat, Hydrocrack, and Fractional Distillation. Each function is executed in a separate and specifically designed unit of the refinement system. The hydrotreat function is the most unique to green crude refinement as it requires a reaction process called hydrodeoxygenation which significantly reduces the oxygen content of the green crude prior to it being hydrocracked. Finally, the physical architecture includes a By-product Management and Disposal Facility that recycles the refinement process by-products to the maximum extent possible. The high-level system concept for the HNAABS refinement system was centered on the functional and physical architecture and optimized for the production of bio-kerosene.

Although the functional and physical architectures stem from petroleum refinement systems that have been effectively operating for years, they are unique to the refining industry due to the unique algae based green crude of the HNAABS refinement system. Grounded on the thorough amount of research and analysis, the HNAABS Project Team feels the system concept described in this section, and the associated attachments of this report, could be utilized in the design of a green crude refinery with an algae based primary feedstock. The system concept could also be successfully implemented on a commercial scale in Hawaii. It could generate new jobs and play a key role in providing Hawaii independence from any imported oil.

## **IV. ENVIRONMENTAL AND LEGAL CONSTRAINTS**

The environmental and legal considerations of developing an algae bio-fuel production system are critical to the success of HNAABS. The subsystem level environmental impacts were discussed in detail in Section III. This section addresses the overarching environmental and legal issues that affect the total HNAABS package. The proposed system will be located on the Hawaiian Islands, which adds additional environmental and legal risks. This section covers environmental and legal regulations and permits that bound the system operation, as well as their impacts on the HNAABS. Additionally, this section also discusses the risks identified for the proposed system along with the risk mitigation strategies. The Team has documented a 42 month permitting cycle that must be accomplished prior to the HNAABS coming online, as well as the treatment standards for toxic waste with which the HNAABS must comply.

### **A. BACKGROUND**

The HNAABS processes are regulated by the environmental and legal issues that are typical of standard fossil fuel refinement. This assertion is supported by the analysis of the proposed cultivation system (Section III.B) and post-processing systems (Sections III.C to III.E). All environmental and legal analysis was based on the final proposed HNAABS solution, PBR growth with Quantum Fracturing™ harvesting and extraction with the hybrid refinement system defined in Section V. Environmental and legal issues are magnified within the Hawaiian Islands due to its more restrictive environmental and legal constraints in comparison to similar facilities such as the Geismar refinery in Louisiana. There were also further limitations on resource allowances, such as power, water, and land as a result of Hawaii's isolated location. Fortunately, algae can be produced and refined using low productivity land areas and low quality water (U.S. Department of Energy 2010). A detailed environmental and legal impact analysis was performed for the proposed system. The environmental analysis defined impacts to the water, land, and air and quantified those impacts in the AoA (Sections III.B to III.E). This analysis was expanded to address how those individual subsystem impacts affect the

state-wide ecology of Hawaii. The legal analysis defined what policies, acts, and permits were required to cultivate and refine algae in Hawaii. It has been concluded that given Hawaii's environmental profile and local legislature, it is feasible to cultivate and refine bio-fuel from algae in the state of Hawaii.

## **B. ENVIRONMENTAL AND LEGAL ANALYSIS SCOPE**

The environmental analysis was conducted using the various constraints and environmental effects dictated by the Roundtable on Sustainable Biofuels Impact Assessment Guide (Energy Center of École polytechnique fédérale de Lausanne (EPFL) 2011). Figure 100 shows a breakdown structure that describes how the environmental analysis defined the problem areas. These problem areas were classified as critical system impacts. The impacts were further categorized as environmental, regulatory, and physical constraints to the final HNAABS system configuration. The impacts that are specific to a subsystem selection were analyzed in detail in Section III.B. By using the Impact Assessment Guide, the Team followed a defined and repeatable approach to capturing all facets of environmental and regulatory constraints for producing bio-fuel from algae in the state of Hawaii.

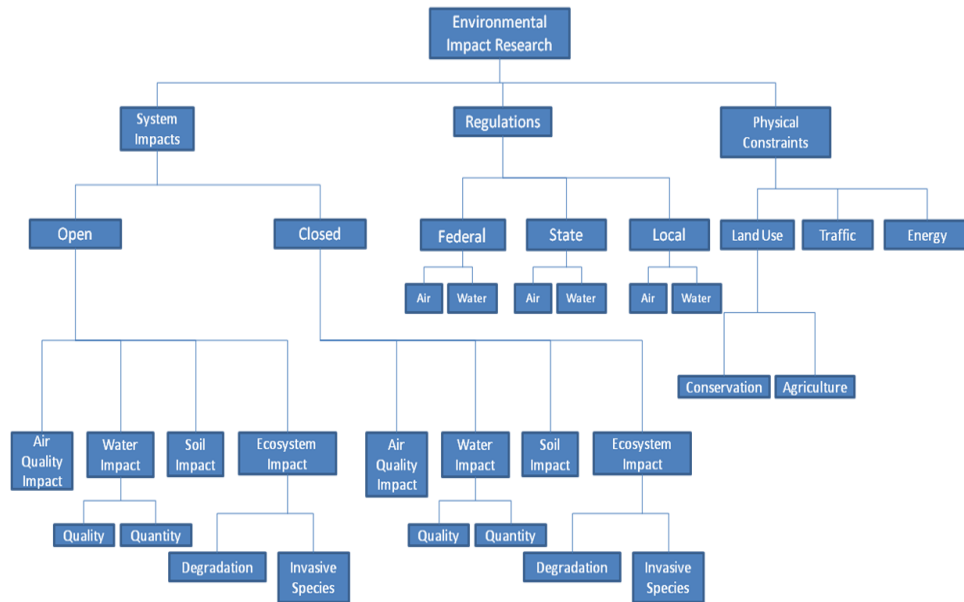

Figure 100. Environmental analysis breakdown structure showing the major areas investigated for environmental and regulatory impacts. There are different impacts to consider depending on whether the growth system is an open-type like the pond or closed like the photobioreactor.

The main areas that are affected by producing and refining algae bio-fuel are land, water, energy, ecosystem, and air, in that order of importance. This ranking of environmental impact areas was provided by stakeholder feedback during IPR-1. The greatest area of concern was land because of the scarcity of usable land in Hawaii. The different land areas are discussed in section C.1.b. The other areas (water, energy, ecosystem, and air) were assessed in the environmental analysis. The environmental assessments of these areas were conducted to ensure that the production and refinement systems had minimal effects on the overall ecological system of Hawaii. Impacts specific to each section of the cultivation system can be seen in section III.B. The legal analysis allowed the team to define a regulations and legal framework governing operations within the legal confines of the state of Hawaii at the federal, state, and local levels. Descriptions of the relevant policies and acts are covered in Section IV.D.

## **C. ENVIRONMENTAL IMPACTS**

### **1. System Impacts**

The environmental analysis recommended that an environmental impact statement (EIS) be conducted on any proposed development site to identify any potential environmental impacts related to the location where the HNAABS is eventually constructed. The National Environmental Protection Agency (NEPA) required that federal agencies prepare an EIS for major federal actions that could affect the quality of the human environment. Due to the significant DoD involvement with the HNAABS, the Team determined this requirement would apply to the project. An EIS is a document that details the process of how the project was developed and includes alternatives with potential impacts (U.S. Department of Transportation Federal Highway Administration 2013). A number of environmental risks based on the EIS were developed and documented through the risk management program (see Section IV.E). To mitigate these risks, the Team recommended that the facility prepare a disaster response plan and a disaster response team in accordance with FEMA Guidelines. The FEMA guidelines can be seen on their webpage (U.S. Federal Emergency Management Agency 2012).

The legal permitting process shall be handled by the organization that is responsible for the day-to-day operation of the HNAABS. The environmental analysis team researched permit issues for the specific site locations that were selected through the requirements identification process. Permit requirements relating to the federal, state, and local levels were collected and organized into the timeline found in Appendix D.

The cultivation and refinement of bio-fuel affects the human environment in the categories of land, water, and air for all potential site areas in Hawaii. The following sections describe how water consumption, water quality, land usage, and air quality affect the local area and the strategies to offset these environmental impacts.

#### ***a. Water***

Wastewater and water consumption are key factors that influence the design of algae cultivation facilities. If chemical treatments such as flocculants are avoided, wastewater can be reclaimed and reused by the cultivation site with a minimum

of processing. Wastewater derived from the dewatering stages of algae production where chemical treatments are used could be captured by a treatment unit and released back into the cultivation system as make up water to reduce the burden on local water resources (Ryan 2009).

Wastewater treatment requirements are dictated by the Hawaii Department of Health (State of Hawaii 2013). The release of wastewater could potentially introduce chemicals, nutrients, additives, and algae, including non-native species, into receiving waters. The objective of the HNAABS final configuration is to minimize output wastewater, maximize recycling of wastewater, and minimize output of chemicals, nutrients, and additives. This was accomplished in the AoA section by addressing the cultivation methods (Growth, Harvest, De-water, and Extraction) and choosing methods with minimal environmental impacts. Quantum Fracturing™ requires little to no chemical treatment and offers multiple low energy opportunities to reclaim wastewater. Furthermore, the HNAABS was designed using *Chlorella* to avoid the possibility of non-native algae species escaping the cultivation system. Laws that regulate wastewater discharge such as the Clean Water Act are discussed in Section IV.D.

Producing and refining bio-fuels introduces many concerns to water management in the local surrounding areas. These concerns include downstream wastewater management, water quality, water consumption, and groundwater issues. Water management must be handled efficiently and the processes must also adhere to restrictions and guidelines set forth by legislation in the Clean Water Act (U.S. Environmental Protection Agency 2008).

(1) **Downstream Water.** Wastewater discharges may spread waste and/or other toxins to other water sources. Downstream water waste was a main concern during the harvesting and processing stages. The Clean Water Act (U.S. Environmental Protection Agency 2008) requires that all toxins are removed and the temperature of the water be managed during discharge to minimize any risks to the ecosystem. The EPA defines toxic pollutants as “those pollutants, or combinations of pollutants, including disease-causing agents which after discharge and upon exposure, ingestion, inhalation or assimilation into any organism, either directly from the

environment or indirectly by ingestion through food chains, will, on the basis of information available to the Administrator, cause death, disease, behavioral abnormalities, cancer, genetic mutations, physiological malfunctions (including malfunctions in reproduction) or physical deformations, in such organisms or their offspring.” (U.S. Environmental Protection Agency 2013). A strategy of avoidance was adopted for the HNAABS design. Any potential occurrence of toxic materials was rated unfavorably in the AoAs and any unavoidable application of toxic materials must be controlled through wastewater management.

Due to the proprietary nature of some aspects of the cultivation and refinement systems, the downstream water wastes may still contain unknown material. This unknown material must be evaluated once a final solution has been contracted to fully address wastewater concerns. In the interim, the waste was correlated with the inputs of the cultivation system. Dissolved solid content of low quality water may consist of calcium, magnesium, sodium, chloride, sulfate, bicarbonate, potassium, nitrate, iron, and fluoride (Ryan 2009). This provides a basis for assessing the initial scope of waste water impacts.

(2) **Water Quality.** Water quality is the measure of how suitable water is for particular uses based on chemical, physical, and biological characteristics. With the use of nutrients and other solids during the cultivation, harvesting, and processing stages of this process, there is a risk that they can affect the local water quality. It is imperative to have a system in place that is designed to improve water quality and rid the water of chemical additives and pollutants, if they exist in the downstream water output (Ryan 2009). The Safe Drinking Water Act assures that water quality is managed to ensure that minimal pollutants or additives are found in water sources. An important tool for assuring water quality is laboratory testing and monitoring to maintain continual compliance. Analytical testing standards for organics, inorganics, radionuclides, and ground water standards are available from the EPA (U.S. Environmental Protection Agency 2012). The Safe Drinking Water act is discussed in a later Section (IV.D). In the AoA Section (III.B), water quality was assessed in the growth, harvest, de-water, and extraction methods. The scoring methods were based on

how the various methods affected the local water sources as well as how much waste the processes produced. This scoring continues to support the HNAABS policy of environmental impact avoidance.

(3) **Water Consumption.** Estimates for water consumption vary widely depending on the cultivation and processing systems used. In 2012, The United State Environmental Protection Agency (EPA) estimated ranges from 25 to 974 gallons of water per gallon of biodiesel produced (U.S. Environmental Protection Agency 2010). The EPA has estimated that an open-system-type bio-fuel facility (such as a pond cultivation system) generating 10 million gallons of bio-fuel each year would use between 2,710 and 9,740 million gallons of saline water each year; a similar scale closed-system-type bio-fuel facility (such as a PBR cultivation system) would use between 250 and 720 million gallons of saline water annually (U.S. Environmental Protection Agency 2010). Numerous strains of algae can be cultivated in brackish water or salt water to alleviate the need to use freshwater sources. One example of a process that uses saltwater is the OMEGA cultivation system which operates on the ocean surface and does not require freshwater at all. Water consumption for this process varies by which cultivation and harvesting methods are used and where the water comes from. If a large open pond is utilized, it requires larger amounts of water, but this is offset by using the wastewater from another source or recycled water. If using a closed PBR cultivation system, heterotrophic, or the OMEGA system, water consumption quantity will only be a minor issue. The water consumption impact analysis was done to assess the effects of water consumption that each step of the cultivation process had on the environment. This assessment can be found in the AoA sections in III.B. The estimates of water consumption between an open pond type cultivation systems compared to a PBR system when producing 10 million gallons of lipid production per year are in Figure 101.

### Water Usage @ 10 MM Gallons Produced (Mil Gal/Year)

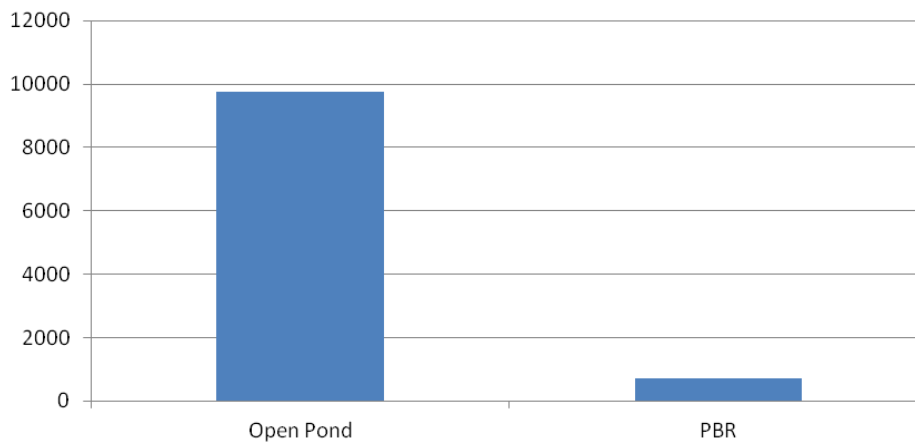

Figure 101. Water consumption of an open pond cultivation system versus a closed photo-bioreactor (PBR) cultivation system when 10 million gallons per year of algae lipid content is produced. This is based on EPA assumptions and should only be used for comparison of pond and PBR cultivation methods. (After U.S. Environmental Protection Agency 2010).

The HNAABS solution of a photobioreactor for growth and a Quantum Fracturing™ system for harvesting and extraction dramatically reduces the amount of water lost during bio-oil production. Even with Quantum Fracturing's™ expected >95% water recovery, the HNAABS system is still expected to lose approximately 5.5 billion gallons to water each year. To address the large water consumption requirements of industrial scale algae cultivation, a salt-water strain of *Chlorella* was used in the system calculations. This dramatically reduces the impact of water consumption on the local community.

(4) **Groundwater.** The groundwater or aquifers are vulnerable to discharge or runoff from the HNAABS Cultivation system, particularly an open pond system or a spill from a closed system such as a photo-bioreactor system (Ryan 2009). When scoring the systems in the AoA (Section III.B), the closed systems had better scores when compared to the open systems such as the Open Pond. The open pond allows for more spills and run-off water than the closed systems thus the system has a higher environmental risk. Because saltwater is used in the HNAABS design, contamination of

ground water remains an issue even after selection of a PBR growth solution. This problem is addressed as a side effect of the requirements to ensure proper management of wastewater. Since the HNAABS will be required to monitor and test water discharge systems, the additional requirements of ensuring salt water does not enter the local environment are considered minimal.

***b. Land***

(1) **Land Requirements.** This section identifies the environmental impacts of land use in Hawaii. To maximize the efficiency, the cultivation system should be co-located near input sources of carbon dioxide, wastewater, or other low quality water for recycled use. Algae grown in conjunction with animal and human wastewater treatment facilities can reduce both freshwater demands and fertilizer inputs, and may even generate revenue by reducing wastewater treatment costs. U.S. companies were using wastewater nutrients to feed algae in intensively managed open systems for treatment of hazardous contaminants (U.S. Environmental Protection Agency 2010).

Figure 102 shows the total plant land requirements for an open pond system versus the closed PBR system in acres needed to produce 10 million gallons of algae lipid production in one year. This data was collected from the EPA Renewable Fuel Standard Regulatory Impact Analysis on page 430 (U.S. Environmental Protection Agency 2010). Land consumption was a factor in all cultivation AoA methodologies (growth, harvest, de-water, and extraction) when environmental parameters were weighted. Sections III.B to III.E detail the scores assigned for land impacts based on cultivation methods.

### Total Plant Land Required @ 10 MM Gal (Acres)

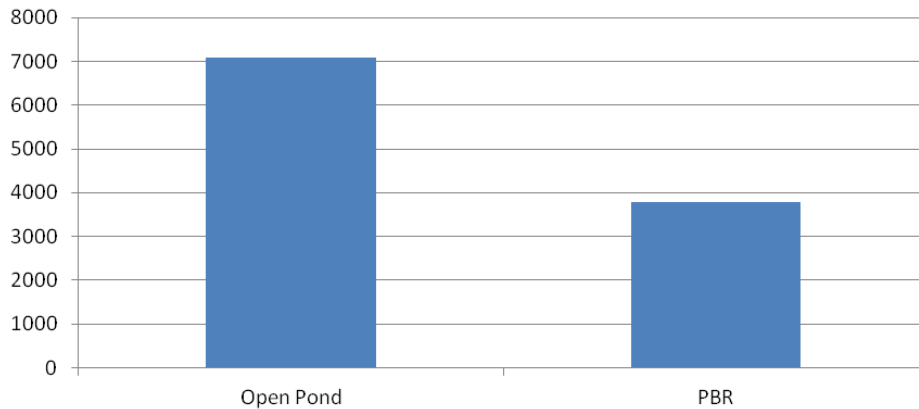

Figure 102. Describes the land requirements (in acres) for production 10 million gallons of algae lipid content for the open pond system versus the photobioreactor system. This is based on EPA estimation and should only be used to compare the open pond and PBR systems. This is a critical issue due to the fact that the system shall be located in Hawaii where usable land is scarce, valued, and protected.

(2) **Land Consumption Efficiency.** The State of Hawaii is broken up into the land zoning categories Urban, Rural, Agricultural, and Conservation by the Land Use Commission (LUC) (Land Use Commission Department of Business, Economic Development, and Tourism; State of Hawaii 2013). The Land Use Commission of Hawaii defines these areas and requires particular permits and judicial actions when acquiring certain lands. The purpose of this Commission is:

In 1961, the Hawaii State Legislature determined that a lack of adequate controls had caused the development of Hawaii’s limited and valuable land for short-term gain for the few while resulting in long-term loss to the income and growth potential of our State’s economy. Development of scattered subdivisions, creating problems of expensive yet reduced public services, and the conversion of prime agricultural land to residential use, were key reasons for establishing the state-wide zoning system.

To administer this state-wide zoning law, the Legislature established the Land Use Commission. The Commission is responsible for preserving and protecting Hawaii’s lands and encouraging those uses to which lands are best suited (Land Use Commission Department of Business, Economic Development, and Tourism; State of Hawaii 2013).

As a result of this zoning law, the environmental analysis considered the size of the facilities and location. Land consumption efficiency was considered in the Analysis of Alternatives (AoA) process for the cultivation system configuration, and systems that used significant amounts of land in relation to other system choices were penalized in the scoring. The refining facility has the potential to be co-located with a current facility. This would help the HNAABS avoid a significant amount of risk in the zoning process.

(3) **Land Permit Considerations.** Depending on the zoning of land selected for facility construction, as defined by the LUC, there are various permit and regulation requirements to be considered. The land districts defined by the LUC are urban, rural, agricultural, and conservation. Hawaii is unique in its abundance of land zoned for conservation. The different districts require different types of permits. The following paragraphs describe each district.

The Urban District is comprised of land containing populated cities. This classification is defined by the people, structures, and services resident in the district. In the district, there are some vacant areas for future development. Jurisdiction of this area lies with the counties. The lot sizes and use permits in this district are established by the county through local rules and regulations (Land Use Commission Department of Business, Economic Development, and Tourism; State of Hawaii 2013).

The Rural Districts are comprised of mostly small farms with small residential lots at a minimum size of one-half acre. Jurisdiction over Rural Districts is shared by the Commission and local county governments. Use Permits detail and limit the activities that can occur in Rural Districts. Variances from those uses can be obtained through the special use permitting process (Land Use Commission Department of Business, Economic Development, and Tourism; State of Hawaii 2013).

The Agricultural District is comprised of lands for the use of the following activities and processes:

- Cultivation of crops
- Aquaculture
- Raising Livestock

- Wind Energy
- Timber Cultivation
- Agriculture Support
- Golf Courses (if land is not high productivity category)
- Golf Related Activities (if land is not high productivity category)

Uses Permits in the highest productivity categories of agriculturally zoned land are issued and controlled by the state. For lower productivity categories, the uses permitted are governed by the Commission.

The Conservation District lands are composed of lands in the forest and water reserve zones that are used for protecting water resources, scenic and historic zones, parks, wildlife, recreational areas, and habitats of endemic fish, wildlife, and plants. The Conservation District also includes land that can be subject to flooding.

The Conservation Districts are governed by the State Board of Land and Natural Resources and uses permitted are issued by rules set forth by the State Department of Land and Natural Resources.

An example of the region districting for the island of Hawai'i in the state of Hawaii shows that a large majority of the island is identified for conservation with small portion allotted to the other district types (Figure 103). The prevalence of conservation land indicates the HNAABS will likely have to process its land use permits through the State Board of Land and Natural Resources.

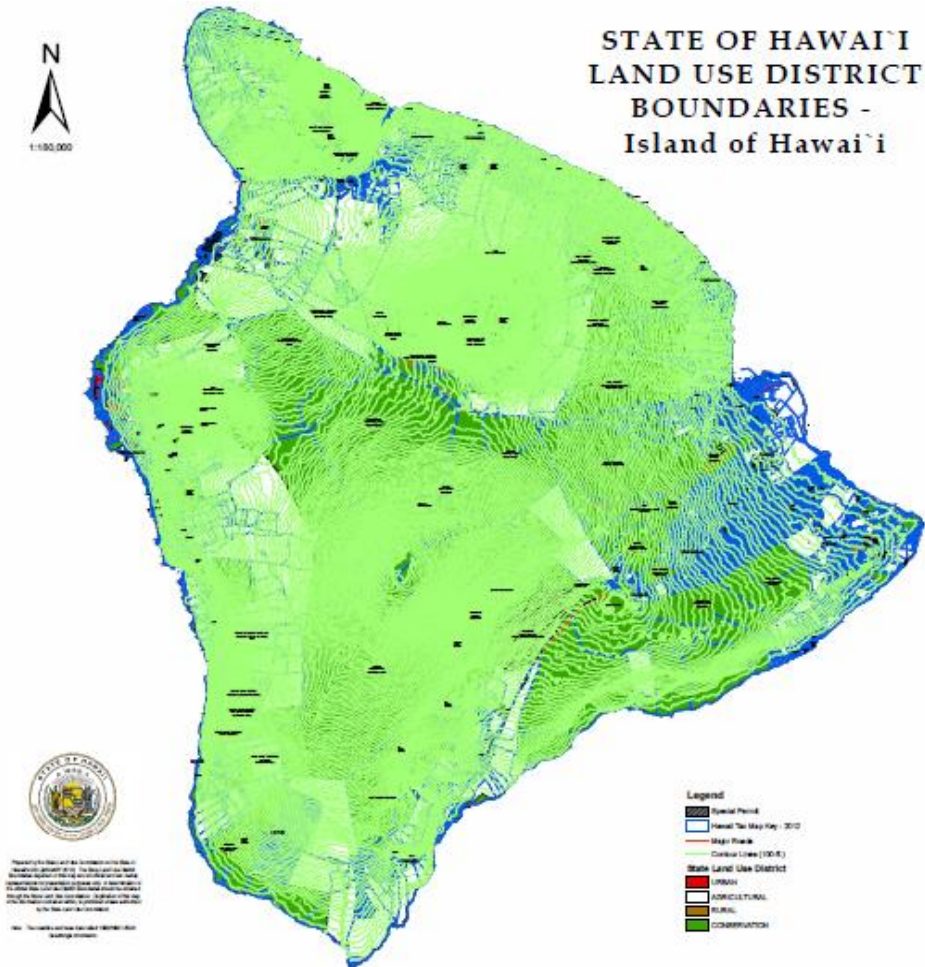

Figure 103. Land boundaries of the Hawaiian island of Hawai`i showing the various district regions with most of the land identified for conservation purposes only (From Land Use Commission Department of Business, Economic Development, and Tourism; State of Hawaii 2013).

*c. Air*

The algae to bio-fuel processes affect the air quality during cultivation and refinement. The evaporation rates were taken into account during the impact assessment process. The evaporation rates depend on water temperature, the area of exposed surface, rate of agitation, and the humidity of the air above the water. For example, a large exposed surface of water in a warm, dry climate has a higher evaporation rate (Ryan 2009). The air quality and evaporation rates were assessed in the AoA portion. This mainly affected the growth methods of algae cultivation. The open pond, photobioreactor, heterotrophic fermentation, OMEGA, and hybrid systems were evaluated for their overall

impact on air quality. The open pond systems had the largest impact on air quality because of its large, open surface area and the closed bioreactor and heterotrophic fermentation systems had the smallest impacts because they are closed systems that are not exposed to the open air. Evaporation from large-scale cultivation systems could potentially affect local and regional humidity, precipitation patterns, and ecosystems. The HNAABS was designed to avoid open air exposure whenever possible. Drying systems were evaluated with air purification and scrubbing systems attached a risk was developed to address refinement air emissions.

## **2. Energy Impacts**

The production process of turning algae into a biofuel consumes energy. The energy inputs that may be required were electricity, heat, pressure, and other energy as required to operate the various technologies (Ryan 2009). One area that was assessed was energy required to cultivate 10 million gallons of algae lipid production in one year. Figure 104 shows the amount of energy required for the open pond as compared to the closed PBR system. This data was collected from an EPA study (U.S. Environmental Protection Agency 2010) A gallon of kerosene contains 39.6 kWh of energy (Annamalai and Puri 2006). This data suggests that it takes 6.2 kWh of electricity to make one gallon bio-fuel using the open pond. The data also shows that it takes 3.57 kWh to make one gallon of bio-fuel using the photobioreactor. This data shows the photobioreactor to be a more energy efficient method. This data was used in the AoA when assessing the energy impacts on the cultivation system.

### Net Annual Electricity Required @ 10MM Gal (Mil kwh/yr)

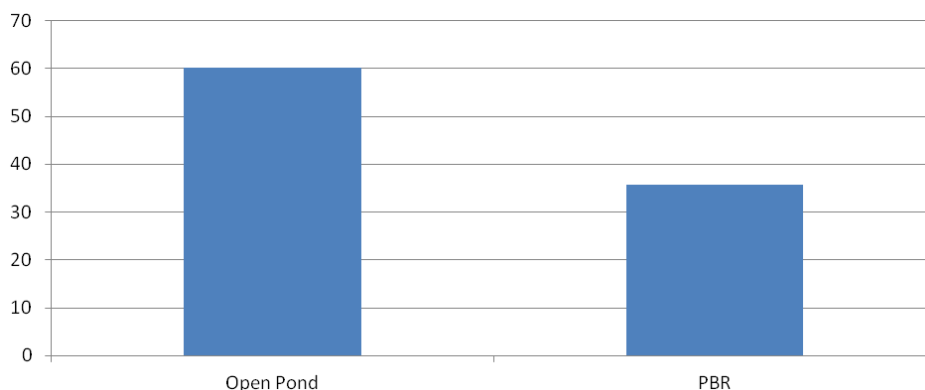

Figure 104. The amount of energy required for producing 10 million gallons of algae lipid content. This chart shows the difference of energy used for the open pond system versus the photobioreactor system for cultivating algae. This is an EPA estimation and should only be used to compare the open pond and PBR systems.

The cost section (Section V.) describes the energy requirements for each part of the algae to bio-fuel process. Hawaii currently requires external electricity inputs from other states to fuel the systems. The energy can be recouped by burning by-products. The total power requirement in Hawaii for HNAABS is 122 million kWh/year. To reduce the impact on the Hawaiian energy grid waste products can be burned by the refinery, including biomass produced by the cultivation system, to reduce energy demands by approximately 60% (U.S. Energy Information Administration 2004).

#### **D. REGULATIONS AND PERMITS**

The USPACOM desired a method to produce locally 25% of military aviation fuel consumed in Hawaii for assured supply, economic development, and to support environmental initiatives (Simonpietri 2011). This section of the paper contains permitting, legislative authorities, and applicable waivers the State of Hawaii requires for developing biofuels from algae. The State of Hawaii recognized its dependency on imported oil and the economic vulnerability created by price volatility of this finite energy source (State of Hawaii Department of Business 2011). Unfortunately, Hawaii's permitting system has been categorized as a major obstacle in a successful

implementation of a bioenergy project. To overcome permitting challenges, the state signed a Memorandum of Understanding with the U. S. Department of Energy to establish the Hawaii Clean Energy Initiative (HCEI) to overcome any detrimental environmental effects on renewable energy development (Hawaii Stage Energy Office 2013). As part of the HCEI, state leadership called for swift improvements in permitting processes through passage of legislative measures affecting the State and County permitting agencies (Siah and Zapka 2009). One of the products developed after the creation of the HCEI was the Federal, State and County Approvals Guidebook for Bioenergy. This guide provides a comprehensive overview of the renewable energy permitting process in Hawaii (Hawaii Stage Energy Office 2013). The guidebooks addressed the need to understand the entire permitting system within Hawaii – which permits are required and the processes for acquiring those permits. The Bioenergy Guidebook must be used in conjunction with the appropriate County Guidebook, as applicable regulations depended on the county or counties selected for bio-fuel production. The applicable regulations will also depend on the details of the final configuration of the system to include cultivation, refinement, requirements and cost.

The decision to award or deny permits is retained by the state or county agencies but it is important to note that new legislation allows the Energy Resource Coordinator in the Department of Business, Economic Development and Tourism (DBEDT) to force a decision to either grant or deny permits no later than 18 months after the approval of a complete permit application (Hawaii Stage Energy Office 2013). It is also required of the DBEDT to identify Renewable Energy Zones (REZ) that are rich in renewable forms of energy, cost effective, and environmentally benign. The environmental study notes that, at the state level, the Hawaii Department of Health (DOH) administers the majority of environmental permits, though other agencies also control permits such as the Department of Land and Natural Resources (DLNR) and the DBEDT (See Figure 105). The Hawaii site study provided critical information to make informed decisions about the appropriate site of the facility. Once the site in a particular county is selected, a clear permitting trail utilizing both the Bioenergy Guidebook (Federal and State) as well as the selected County Guidebook will be determined.

DBEDT estimates the number of permits that may be required for a renewable energy project could reach as high as 109 (Siah and Zapka 2009). The State of Hawaii Energy Office website (<http://wizard.hawaiiicleanenergyinitiative.org/>) has developed a wizard to assist in determining which permits are required based on the specific details on the location and configuration of HNAABS.

According to Siah and Zapka 2009, permits in Hawaii can be categorized into four main groups: (1) environmental permits and reviews, (2) construction and operations permits, (3) land use permits, and (4) utility permits. The administering agencies (Figure 105) include the Hawaii Department of Health, Department of Land and Natural Resources, Environmental Protection Agency, Office of Planning, Department of Agriculture, U.S. Army Corps of Engineers, Department of Business, Economic Development and Tourism and County Offices. These agencies assess different aspects of the project and issue permits required for the construction and operation of a biofuel project. The federal environmental requirements that apply to the proposed final system configuration for production of biofuel from algae within the state of Hawaii include but are not limited to the following:

- National Environmental Policy Act (NEPA): NEPA is the legislation that establishes national environmental policies in the United States. It applies to all federal projects, and any project requiring a federal permit, receiving federal funding, or located on federal land. It requires federal agencies to incorporate environmental considerations in their planning and decision-making and to prepare a detailed statement assessing the environment (U.S. Environmental Protection Agency 2008)
- Renewable Fuel Standards (RFS) Program: The program applies to facilities that produce 10,000 gallons or more of renewable fuel per year. Requirements include Fuel and Fuel Additive Registration System (FFARS) program; Generate, transfer and record Renewable Identification Numbers (RINs); Abide by Blending Requirements (Siah and Zapka 2009).
- Clean Water Act (CWA): The CWA establishes the basic structure for regulating discharges of pollutants into the waters of the United States and regulating quality standards for surface water. The federal government has transferred regulatory authority of the CWA to the state of Hawaii (U.S. Environmental Protection Agency 2008).

- Dredging and Filling Permit: Regulations developed under the CWA program addresses the discharge of dredged or fill material into waters. It requires a permit before these materials may be placed in wetlands, streams, rivers, sloughs, lakes and bays during construction activities. The U. S. Army Corps of Engineers administers the issuance of permits, enforcement, and making determinations on what constitute a “water of the U.S.” (U.S. Environmental Protection Agency 2008).
- Storm Water Construction Permit (if applicable): Storm water permits are required for discharges to waters of the U.S. from any construction activity that disturbs one acre or more of land to minimize the impact of site run off on water quality. Land disturbed caused by construction, such as clearing, grading, and excavating can lead to serious environmental harm in both nearby and downstream water bodies (U.S. Environmental Protection Agency 2008).
- Safe Drinking Water Act: It is the federal law that ensures the quality of drinking water for Americans and requires many actions to protect drinking water and its sources, such as rivers, lakes, reservoirs, springs and ground water wells (U.S. Environmental Protection Agency 2008).
- Water Use Permit: Withdrawing or using water from a surface or underground source typically requires a water use permit, depending on the volume of water that will be used daily (U.S. Environmental Protection Agency 2008).
- Clean Air Act: It requires the Environmental Protection Agency (EPA) to set national ambient air quality standards for widespread pollutants from numerous and diverse sources considered harmful to public health and the environment (U.S. Environmental Protection Agency 2008).
- Air Construction Permit (if applicable): Established from the Clean Air Act, the Air Construction Permits is a pre-construction permitting program in order to preserve and protect the national ambient air quality standards and enhance air quality. There are two kinds of construction permits – major or minor construction permits, and the permits required depends of the facility’s potential to emit pollutants and the location of the facility (U.S. Environmental Protection Agency 2008).
- Pollution Prevention Act: The act is put in place to prevent pollution practices by eliminating or reducing waste at its source. The effort is to stop something from becoming waste in the first place (U.S. Environmental Protection Agency 2008).
- Toxic Substance Control Act (TSCA): The act gives the EPA broad authority to identify and control chemical substances that may pose a threat to human health or the environment. EPA’s New Chemical Program, located in the Office of Pollution Prevention and Toxics is established to help manage the potential risk from chemical substances to

include genetically modified microorganisms (U.S. Environmental Protection Agency 2008).

- Resource Conservation and Recovery Act (RCRA): RCRA regulates solid and hazardous waste. Each facility is responsible for determining if each waste stream is hazardous and managing it appropriately if it is hazardous (Siah and Zapka 2009).
- Emergency Planning and Community Right-to-Know Act: Requires facilities with regulated chemicals above threshold planning quantities to prepare comprehensive emergency response plans. The regulations require reporting of spills of hazardous chemicals which are above a certain volume (Siah and Zapka 2009).

Figure 105 describes the various entities and organizations that must be consulted and interacted with regards to Renewable Energy Permits (color coded purple). Other certificates and permits issued by the Hawaii Department of Health's divisions are color coded orange. In conclusion, location plus potential impacts equals permit pathway (Hawaii Congress of Planning Officials 2012).

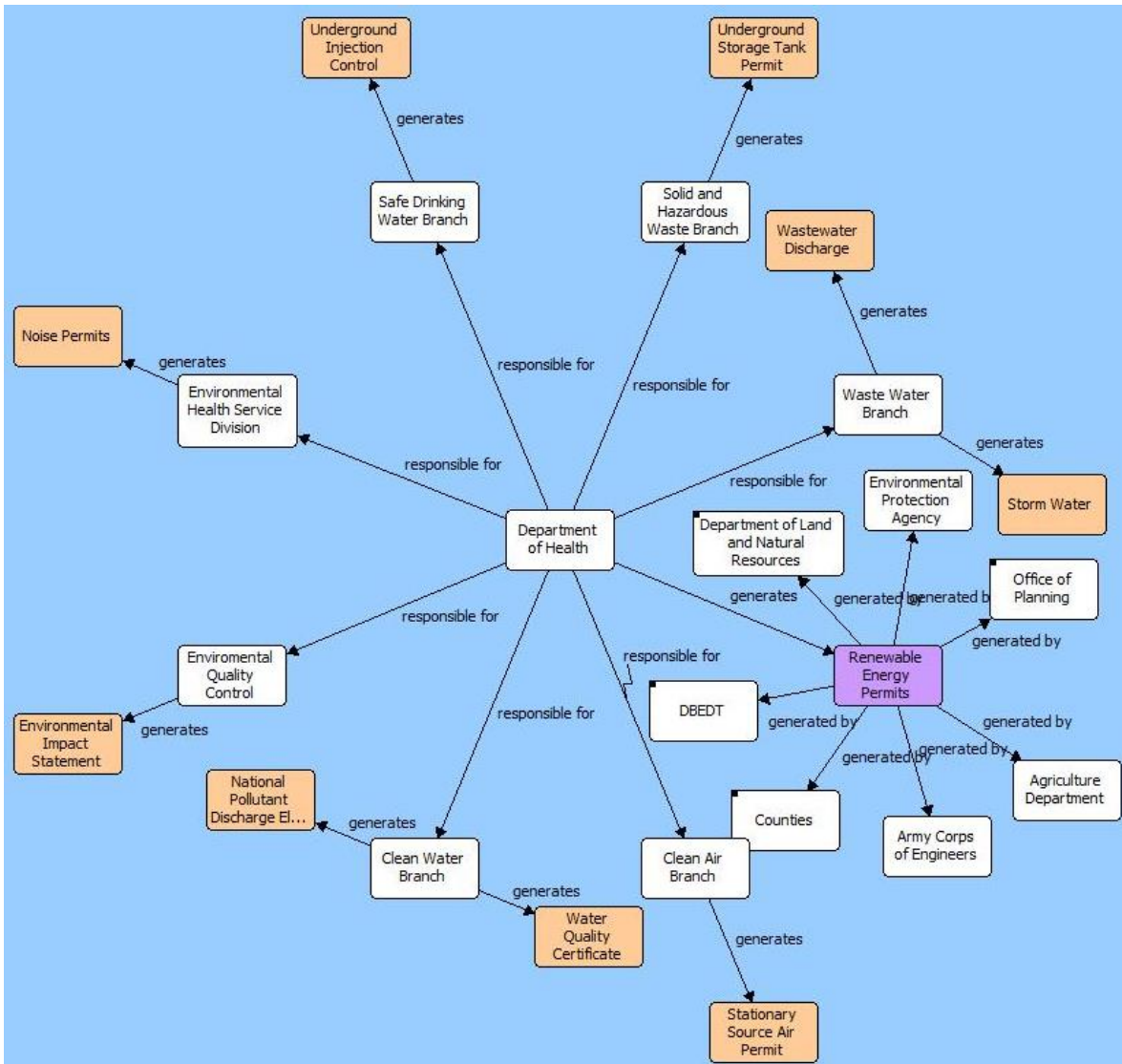

Figure 105. The regulatory and issuing permit authorities required for construction of a algae biofuel production facility within the state of Hawaii along with the product permits and certificates.

## **E. ENVIRONMENTAL RISKS AND MITIGATION STRATEGIES**

### **1. Risk Identification**

The HNAABS environmental team used the processes identified by the Hawaii Natural Energy Institute (Hawai'i Biofuel Foundation and NCSI Americas Inc. 2011) to assess the environmental risks of this project. The process was created by the Roundtable on Sustainable Biofuels (RSB.org) and the document is titled: RSB Impact Assessment Guide [RSB-GUI-01-002-01 Version 2.0] (Energy Center of École polytechnique fédérale de Lausanne (EPFL) 2011).

The Team conducted an environmental analysis that identified areas that pose the greatest risk. The Team categorized the risks as high, moderate, or low in accordance with the Risk Management Plan (see Appendix C). This categorization enabled the Team to compare system configurations.

Important risks that have been identified are:

- Risk 1. Invasive Algae species invading the local Hawaii ecosystem
- Risk 2. Regulation and/or statute changes during and implementing the changes causing a cost increase
- Risk 3. Keeping air emissions at acceptable levels in Hawaii during refinement
- Risk 4. Untreated waste water discharge
- Risk 5. Consuming too much of the local water sources for algae production
- Risk 6. Land use complications causing schedule slip

### **2. Risk Mitigation Strategies**

Each of the six important risks identified are described in detail along with the strategy to mitigate such risks.

#### ***a. Risk 1: Invasive Algae***

As over 80% of plants in Hawaii that are considered endangered are threatened by invasive species (Wilcove, et al. 1998), uncontrolled algae pose a serious danger to the local ecosystem. The environmental impact study documents uses of non-

native algae species to ensure the system is safe to the ecosystem (Martin 2004). *Chlorella* is native to Hawaii, but has low percent oil by weight. It serves to mitigate this risk, however more lipid dense species of algae may be necessary for system feasibility, thus justifying this risk. Figure 106 describes the allocation and information of Risk 1 in detail.

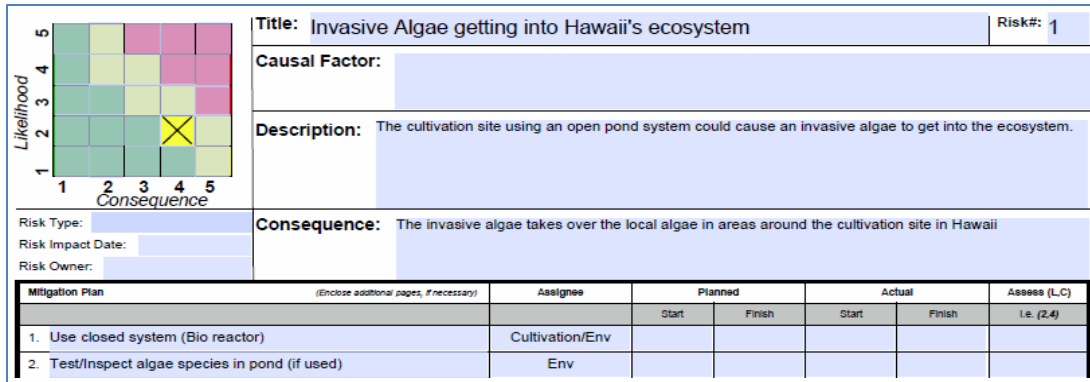

Figure 106. Invasive algae risk details.

**b. Risk 2: Regulation Requirements**

Regulations and statutes are dictated by federal, state, and local governments. There is an inherent risk that changing regulatory requirements, such as judicial interpretations and case law changes, could disrupt the biofuel production process (Stefani 2013). Another source of regulatory risk is cost increases related to handling of system materials, most frequently waste. This is partially mitigated by the relatively low cost of waste disposal. The HNAABS waste management budget was calculated to contribute \$0.0025/gal to the overall fuel costs, indicating even drastic changes in waste disposal legislation should be manageable. The cost value can be found on Table 76. Figure 107 describes the allocation and information of Risk 2 in detail.

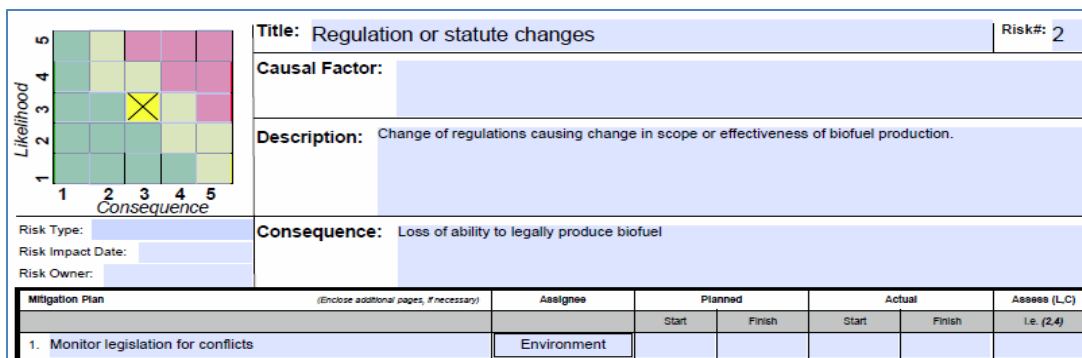

Figure 107. Regulation requirements risk details.

**c. Risk 3: Air Emission Levels**

Air emission limits are set by the Hawaii Department of Health (Hawaii Department of Health 2011) and were used by the environmental team to determine capacity/capability thresholds. All volatile air emissions will be monitored by the state of Hawaii and constrained to ensure no negative environmental impacts. If air emission levels are not met, legal actions result. Figure 108 describes the allocation and information of Risk 3 in detail. To address air emission levels, HNAABS will be expected to develop a self-monitoring and reporting system that will enable the biofuel operators to detect rising emission levels before the result in fines or sanctions by the State of Hawaii. Additionally, all dewatering methods were considered with optional air quality systems attached.

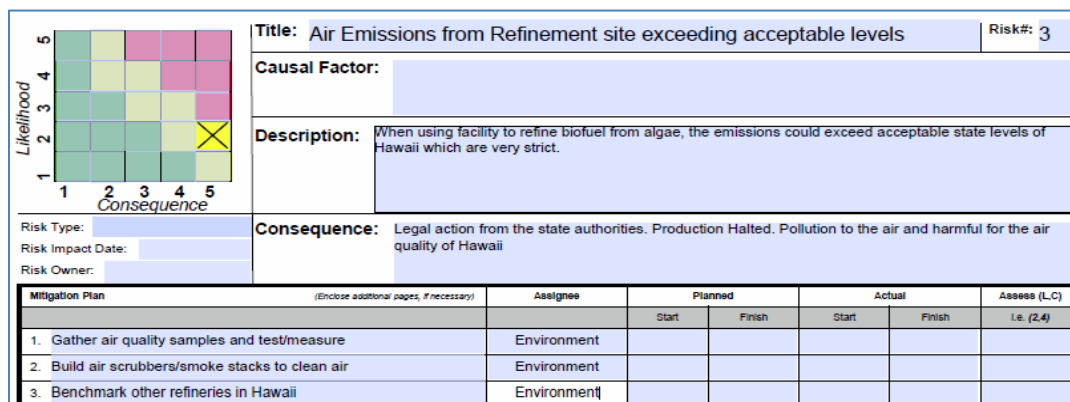

Figure 108. Air emission levels risk details.

**d. Risk 4: Untreated Wastewater Discharge**

Wastewater discharge is regulated by the State of Hawaii Department of Health. Wastewater from the cultivation, dewatering, and refinement phases will be treated before being released to the environment as dictated by the Hawaii Wastewater Regulations Chapter 11-62 (Hawaii Department of Health 1997). All facilities and system equipment will be monitored periodically for wastewater leaks and damage (U.S. Environmental Protection Agency 2013). The systems chosen have low inherent risk of water discharge, so much of this risk was mitigated during the HNAABS design. Figure 109 describes the allocation and information of Risk 4 in detail.

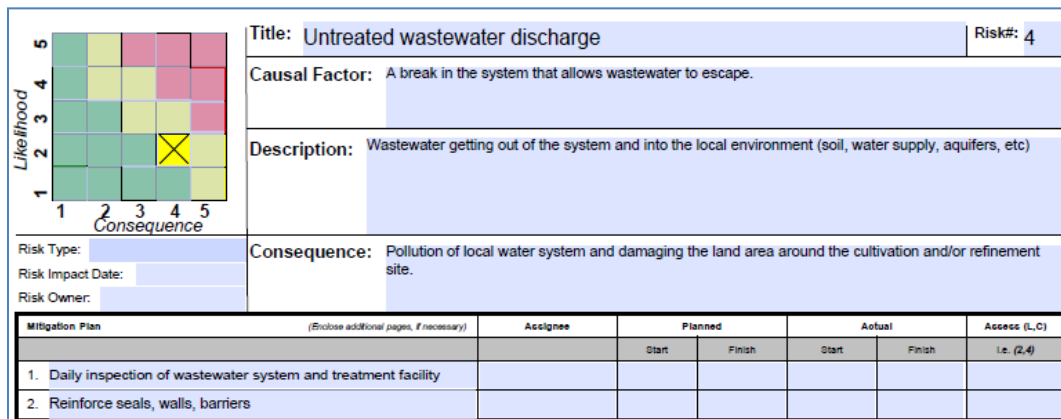

Figure 109. Untreated wastewater discharge risk details.

**e. Risk 5: Water Consumption Level**

The State Water Code, Chapter 174C, Hawaii Revised Statutes, dictates the plan for comprehensive water resources planning to address the problems of supply and conservation of water in Hawaii (Commission on Water Resource Management 2013). The Availability of water for biofuels production in Hawaii is a critical factor in biofuel production. The cultivation of irrigated crops requires substantial quantities of agricultural water and it is unclear whether there are sufficient water resources to meet the demand for the 20% alternative fuel standard (Rocky Mountain Institute 2006). Based on the available water resources in Hawaii, a freshwater algae strain was determined to

be infeasible. Specifying a salt water algae strain has allowed the HNAABS to avoid this risk. Figure 110 describes the allocation and information of Risk 5 in detail.

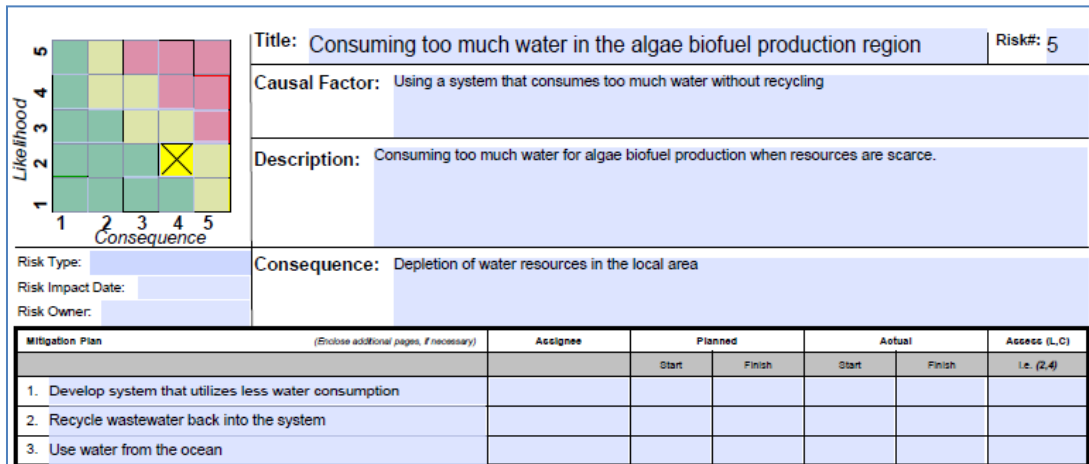

Figure 110. Water consumption level risk details.

**f. Risk 6: Land Use Complications**

Environmental documentation will be in place before any funding obligations are made. The risk mitigation strategy is to have environmental impact assessment and permits in place to avoid risk of time lost due to litigation and inability to use of obligated funds (Stefani 2013). Figure 118 describes the allocation and information of Risk 6 in detail.

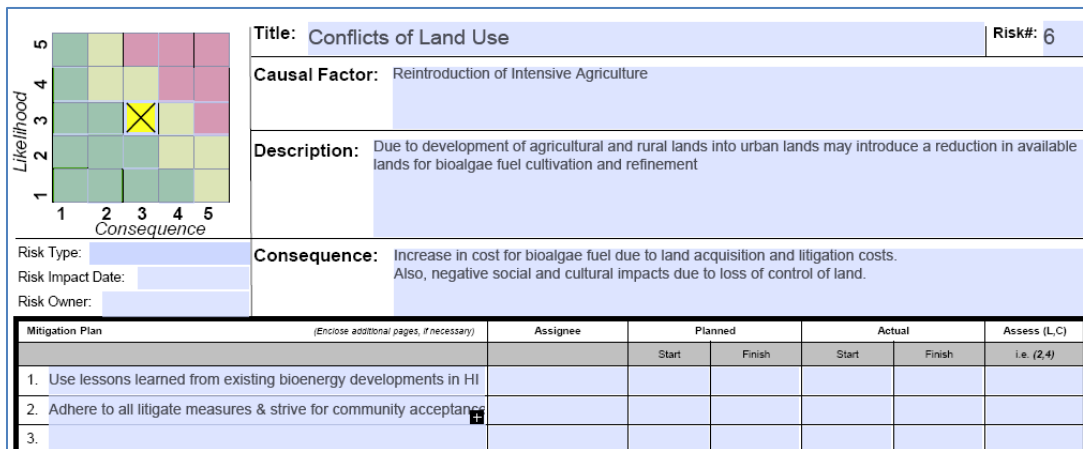

Figure 111. Land use complications risk details.

## F. ENVIRONMENTAL METRICS

To assist in the decision for the final configuration of the algae bio-fuel production system several metrics were developed. This provided the environmental team with a documented and repeatable process to quantitatively compare alternative configurations. This objective criterion to compare the proposed methods of bio-kerosene production against one another is detailed in the AoA portion (Section III.B). The metrics are also displayed in Section IV.C. These metrics are as follows:

- Water consumed per year to produce bio-kerosene (gal/yr)
- Energy usage per year to produce bio-kerosene (kWh/yr)
- Total land usage to produce bio-kerosene (Acres)

Once a system is in place to produce algae and create bio-fuel, sustainability metrics must be in place to ensure minimal environmental impact and legal compliance at the federal, state, and local levels of Hawaii. Some sample metrics for sustainability are as follows:

- Amount of hazardous waste generated per month
- Quantity of toxic chemicals released per month
- Number of notices of violation per month
- Type/volume of non-regulated materials recycled per month
- Type/volume of non-regulated materials disposed per month
- Amount of dollar fines per year
- Number/type of reportable releases per month
- Permitted air emissions per month
- Amount/type of fuel used per month
- Amount of water used per month
- Total annual EHS operating costs per month
- Number of regulatory inspections per month
- Ozone depleting substance used per month
- Total annual EHS capital costs per month

This allows for the maintainers of the overall system to track environmental progress as well as maintain legal compliance.

## **G. RESULTS AND RECOMMENDATIONS**

The environmental analysis has taken into account many of the possible environmental impacts, as well as regulatory actions and permits, to help aid in the system selection and feasibility analysis. While costs and performance are traditional considerations in alternative selection, environmental factors were included in the AoA process to address the difficulties in constructing a system in Hawaii. The environmental impacts taken into account are as follows:

- Land use
- Water Quality
- Water Quantity
- Water Usage
- Ecosystem Impacts
- Energy usage

The environmental analyses can be found in Section IV.B. Another impact taken into account was the waste stream and how to manage the waste from the processes used to produce algal oil. Some methods produce more waste and wastewater than others, but there are currently strategies in place to manage waste so that it does not affect the local environment and surrounding areas. Some examples of this include the Pollution Prevention Act and the Clean Water Act which are described in detail in Section IV.D.

The United States federal agency that regulates the environment is the EPA (Environmental Protection Agency), which is in charge of enforcing regulations such as NEPA (National Environmental Protection Act). The EPA requires that permits be obtained to produce bio-fuel (U.S. Environmental Protection Agency 2011). Also, since the oil is being produced in Hawaii, state regulations and permits must be followed, including the development of an Environmental Impact Statement (EIS) and acquisition of Storage Tank Permits (Hawaii Department of Health 2012). Lastly, permits are required at the local and county levels. These permits and certificates include zoning and

building permits because although existing refinery facilities could be retrofit, cultivation systems to not exist on the scale of the HNAABS. These laws depend highly on the location of the facilities and operations. Mitigating action would include performing an environmental risk assessment prior to building the chosen system.

Environmental advantages and disadvantages of cultivation subsystems are detailed in the analysis of alternatives (detailed in Section III.B). However, this does not address adverse environmental impacts related to the system as a whole. To manage these system level impacts, the HNAABS Team has identified some general policy recommendations to minimize environmental impacts.

Co-location with a current production facility can minimize many of the impacts discussed in this section. By co-locating with another facility, it reduces usage of land which is scarce in the state of Hawaii. Water quality and quantity must be controlled and regulated which is made easier when portions of these controls are already constructed and in use by an existing facility. Furthermore, Cultivation is a water intensive process. This process cannot allow wastewater to harm or affect the local population.

Environmental policy should be reviewed periodically to ensure that the production of oil is maintained within the confines of the law. If policy is not reviewed, there are schedule and cost risks involved due to potential fines and lawsuits (Stefani 2013). The policy can be reviewed by periodically checking for the latest Acts and permits issued at all levels of government. The permitting wizard that was discussed in a previous section (IV.D) is a useful tool to ensure all compliance documents are up to date and on schedule.

THIS PAGE INTENTIONALLY LEFT BLANK

## V. FINDINGS AND RECOMMENDATIONS

### A. FINAL CONFIGURATION ANALYSIS

The Cultivation Subsystem AoA process resulted in the subsystem recommendations shown in Table 74. These systems represent the top scoring results from each of the AoA processes. Depending on stakeholder priorities for cost, performance, technical risk, and environmental risk, alternate subsystems may appear more ideal.

Subsystem	Configuration
Growth	Photobioreactor
Harvesting	Microfiltration
Dewatering	Flash Dryer
Oil Extraction	OriginOil Quantum Fracturing™

Table 74. Recommended cultivation subsystems.

A crucial factor of the subsystem AoA approach was that each subsystem was analyzed in parallel by separate teams. This introduced the risk that the resulting recommended configurations might not be compatible. For example, the OriginOil Single Step Extraction™ method used in the Quantum Fracturing™ process shown in Table 74 does not require the use of either the harvest or dewatering subsystems. The algal biomass passes directly to the extraction process from the PBR facility. Another important result was that the oil extraction AoA process did not produce a clear recommendation as the chemical extraction process utilizing di-methyl ether (DME) scored almost as well as the Quantum Fracturing™ process.

The final AoA recommendation resulted in two competing configurations. The first design alternative utilized a photobioreactor for the growth system and Quantum Fracturing™ as the Single-Step Extraction™ Subsystem. The second alternative utilized a photobioreactor for the growth system, microfiltration for the harvest process, flash dryers for the dewatering process, and chemical (DME) extraction for the extraction subsystem. A summary of the two alternatives is shown in Table 75.

	Growth	Harvest	Dewatering	Extraction
Configuration 1	Photobioreactor	OriginOil Quantum Fracturing™		
Configuration 2	Photobioreactor	Microfiltration	Flash Dryer	Chemical DME

Table 75. Cultivation configuration analyzed.

A comparison from various perspectives of cost, performance, risk, environmental, and consumption factors was performed to determine the recommended final configuration. Since both configurations call for photobioreactor farms as the growth system, the following section describes the production and consumption estimates for a photobioreactor farm utilizing SimGae™ photobioreactor systems (Carlson, et al. 2010).

### 1. Configuration Alternative 1

The Configuration 1 design requires only two subsystems for the cultivation system: photobioreactors for growth, and the patented Single-Step Extraction Method™ from OriginOil known as Quantum Fracturing™. In this configuration, arrays of photobioreactor tanks are used for algae growth. Once the algae have grown to a mature stage, the biomass within the tanks is sent directly to the single-step AlgaeAppliance™ system that performs oil extraction within a single subsystem. The extracted algae oils can then be sent to the processing facility for refinement, while roughly 99.7% of the process water is recycled back into the photobioreactor systems (Carlson, et al. 2010).

A concept of this configuration can be seen in Figure 112. The extraction process works in two stages. The first stage is primarily a dewatering process where the electrical charge of the medium is neutralized in such a way that causes the algae to flocculate (group together). The second stage concentrates the algae to the top by injecting carbon dioxide at high pressure. The algae are ultrasonically agitated to the point where the cell walls rupture. The output of the extraction process is a highly concentrated separated and dried algae with ruptured cell walls allowing the oils to be easily extracted. The algae then pass through a gravity clarifier that separates the remaining water and biomass from the oil.

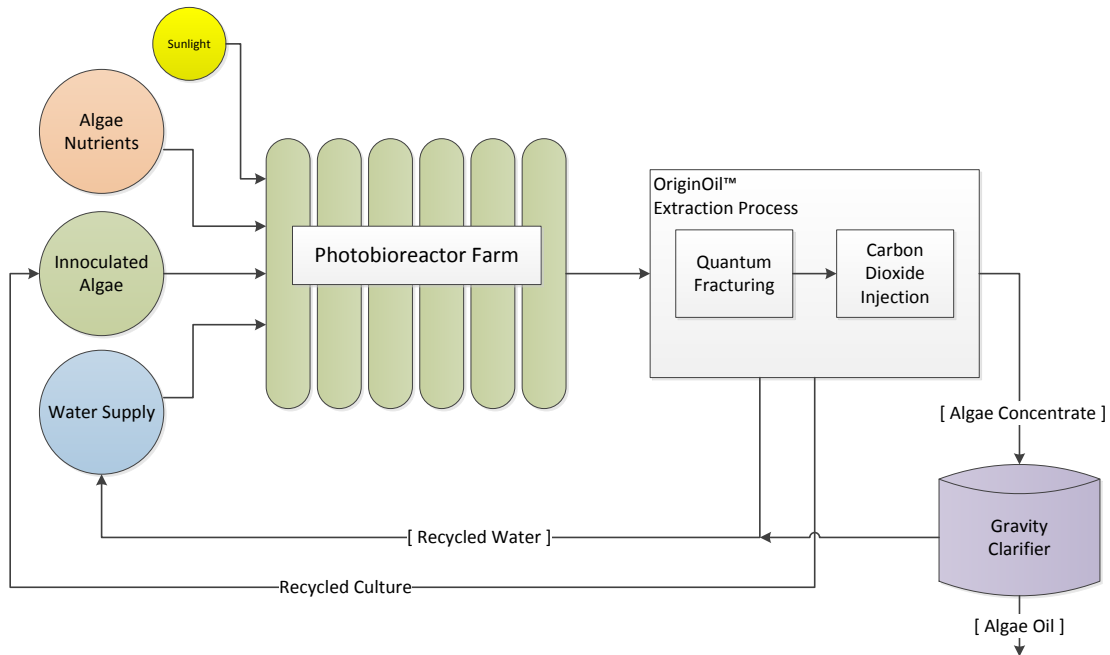

Figure 112. Cultivation configuration 1 concept.

A key advantage of the Quantum Fracturing™ extraction process is that no chemicals are used whereas the other configuration relies heavily on chemicals that pose risks to the environment. This is an important consideration as the Cultivation System was designed to be located within Hawaii in a very environmentally sensitive region. The energy consumption is relatively low compared to other harvest, drying, and extracting methods. Furthermore, this extraction process is continuous and is beneficial for large scale extraction solutions, by eliminating the need to work in batches.

Additional advantages include the fact that the extraction system is strain independent. Also, the system is advertised to work with any water salinity and temperature. Despite the many advantages, there are concerns with this configuration. The extraction process is proprietary and its technical maturity is low. There are no detailed independent publications reporting whether the advertised advantages and features are accurate. Although there are multiple fielded systems by OriginOil, none of them are representative of the scale required for the HNAABS Cultivation System design. Based on company advertisements, large scale systems are in development and are set to be deployed to industrial scale systems in Australia within the next few years.

Cost, performance, and consumption quantities are derived directly from company publications and data.

## **2. Configuration Alternative 2**

Unlike the two-step process representing the first configuration alternative, the second configuration alternative requires four distinct steps to produce green crude bio-oil for refinement. This cultivation solution includes the use of photobioreactors to cultivate the algal biomass, a microfiltration system to harvest the wet biomass material from the growth medium, flash dryers to remove excess water from the biomass, and a chemical DME process for oil extraction. These options were chosen as they were among the top scoring techniques from the individual AoA results.

The PBR growth process, described in the previous section, remains unchanged between the two options. In the second configuration alternative case, however, the wet biomass is harvested using a filtering process with a pore size designed to capture the particles of the chosen algae strain. The amount of biomass to be harvested is dependent upon system throughput requirements. Based on the overall system goal to produce 32 million gallons of refined biofuel per year, estimates for cost, land usage, and power requirements were developed by the HNAABS Team. Accounting for factors such as the concentration of algae in a typical PBR process and the oil concentration of the salt water chlorella strain used in the analysis, it was determined that the growth process must produce roughly 168 million gallons of wet biomass per day.

The microfiltration process captures the algal biomass and separates the solids and liquids to form algal slurry with an assumed total suspended solids percentage of 25%. The total reduction in water during this stage is estimated at about 164 million gallons of water per day. Ordinarily, microfiltration poses minimal environmental risks, and the waste water can be recycled back through the growth process. Based on the cell size of the chlorella algae strain, however, a preliminary flocculation step would likely be required to aggregate the algae particles into clumps large enough to be filtered, thereby complicating the treatment of the harvest process waste stream. Based on cost analysis figures captured in a study to develop a 40 million gallon per day microfiltration facility,

it was assessed that three and a half acres would be required to house the microfiltration facility at a total annual operating cost of about \$16,910,270 or about \$0.53 per gallon of refined biofuel (PB Water 2001).

The final other processes incurred in Configuration 2 include Dewatering via Flash Drying and the dimethyl ether process. The scope of the dewatering system is of the same order of magnitude as in Configuration 1. The dewatering process will still require approximately 180 Million kWh of energy to dry the amount of biomass needed to be dried by HNAABS. However, the greatest area of risk was in the DME process. Though data on the commercial usage of DME is available, data on operations and investment cost was found to be very rare. From an operations cost perspective, there was much cost risk in implementing a process such as DME.

## **B. FEASIBILITY AND COST ANALYSIS**

### **1. Affordability Cost Objective**

In this thesis, the Cost Team addressed the cost to build the Cultivation and Refinement system, with the primary focus of recommending the optimal alternatives that minimized the Free On-Board cost of bio-kerosene. The direct cost associated with bio-kerosene was assumed to be independent of petroleum-based fuels. The objective was to find a solution to satisfy the Operating Cost Key Systems Attribute (KSA) of \$3 per gallon, defined in Section I.A. In this heightened level of budget and funding uncertainty, there must be a KSA associated with Ownership Cost (in HNAABS's case, Operating Cost). The affordability target of \$3 per gallon is known as the Free On-Board cost of fuel. This term is a trade phrase meaning that the seller (industry partners of HNAABS) must deliver a product to the buyer (U.S. Navy) for vessel or aircraft utilization.

### **2. Cost Estimate Creation and Assumptions**

The following sections will describe the cost estimates of the Cultivation and Refinement systems of HNAABS. The cultivation system cost was estimated on the subsystem level and calculations were made for each process: growth, oil extraction, and dewatering. The operating cost of a hybrid refinery was also estimated, accounting for

cost of materials, labor, maintenance, and other items. Cost estimates are necessary to support decisions on economic viability of a project, and, if funded, to develop a baseline by which to measure performance. The primary purpose of the following estimates were to assess the economic viability and determine if the combined cost of the Cultivation and Refinement system alternatives will meet the KSA of \$3 per gallon.

A rough-order-of-magnitude (ROM) figure was calculated from research and academic studies of publicly available laboratory and commercial data of analogous systems. This type of data was utilized in the absence of information and resources available to complete a bottom-up engineering estimate. A cost model was used to derive capital (investment) costs, operations costs (such as material, electricity, and maintenance cost), and labor cost. These costs were scaled to the scope of the throughput requirement of 32 million gallons of fuel produced in one year.

HNAABS Team conducted research to estimate the operating costs of the proposed bio-kerosene system by accounting for the capital, operating, and manpower costs to sustain the process. Capital costs included the investment costs involved in getting the facilities up and running. In other research, elements of capital costs included costs associated with building new facilities and the cost to buy/lease land. However, referring back to initial project scope, capital investment of building new facilities in Hawaii were not accounted for in this estimate. Funding for investment dollars to build new or retrofit legacy facilities for asset production is scarce. This led to the inclusion of investment funding as program risk. Capital costs were omitted from the calculation of the Free On-Board cost of energy. The calculations for the production equipment capital costs can be detailed below, however, the steady state Free On-Board cost of energy will include operations and manpower cost only.

Operating cost included estimates of materials, energy, and maintenance costs. Manpower includes the cost of labor in the production process. Due to the general inability to purchase land in Hawaii, the reoccurring land lease costs were considered as part of the Free On-Board cost of producing bio-kerosene as an operating cost. Below in Tables 76 is a breakout of operating cost for the cultivation HNAABS sub-systems.

<b>HNAABS Cultivation Annual Operating Cost</b>			
	Capital Cost (\$K)	Operating Cost (\$K)	\$/Gallon Contribution
<b>Permit Cost</b>		<b>\$ 100</b>	
<b>Intersystem Transport</b>		<b>\$ 1,927</b>	<b>\$ 0.06</b>
Electricity Cost		\$ 1,927	\$ 0.06
Infrastrucrture Cost	\$ 4,214	\$ -	\$ -
<b>Growth Cost - PBR</b>	<b>\$ 195,288</b>	<b>\$ 175,130</b>	<b>\$ 5.47</b>
<b>Operations Cost</b>		<b>\$ 80,745</b>	<b>\$ 2.52</b>
Land Cost		\$ 55,185	\$ 1.72
Materials Cost		\$ 5,046	\$ 0.16
Electricity Cost		\$ 19,715	\$ 0.62
Maintenance Cost		\$ 799	\$ 0.02
<b>Manpower Cost</b>		<b>\$ 94,385</b>	<b>\$ 2.95</b>
<b>Oil Extraction Cost - Quantum Fracturing™</b>	<b>\$ 256,452</b>	<b>\$ 31,573.1</b>	<b>\$ 0.99</b>
<b>Operations Cost</b>		<b>\$ 31,481.1</b>	<b>\$ 0.98</b>
Land Cost		\$ 17	\$ 0.00
Materials Cost		\$ -	\$ -
Electricity Cost		\$ 31,152	\$ 0.97
Maintenance Cost		\$ 312	\$ 0.01
<b>Manpower Cost</b>		<b>\$ 92</b>	<b>\$ 0.00</b>
<b>Dewatering Cost - Flash Drying</b>	<b>\$ 19,740</b>	<b>\$ 75,244</b>	<b>\$ 2.35</b>
<b>Operations Cost</b>		<b>\$ 74,968</b>	<b>\$ 2.34</b>
Land Cost		\$ 55.4	\$ 0.00
Electricity Cost		\$ 63,052	\$ 1.97
Materials Cost		\$ 11,117	\$ 0.35
Maintenance Cost		\$ 742.3	\$ 0.02
<b>Manpower Cost</b>		<b>\$ 276.0</b>	<b>\$ 0.01</b>
<b>Cultivation Annual Cost</b>	<b>\$ 475,694</b>	<b>\$ 283,974</b>	<b>\$ 8.87</b>
<b>Biomass Resale/Tax Credit</b>		<b>\$ (78,152)</b>	<b>\$ (2.44)</b>
<b>Net Cultivation Annual Cost</b>		<b>\$ 205,822</b>	<b>\$ 6.43</b>
<b>Cultivation Free On Board \$/Gallon</b>	<b>\$ 21.30</b>	<b>\$ 6.43</b>	

Table 76. HNAABS cultivation annual operating cost.

Table 77 shows a breakout of operating cost for the refinement HNAABS sub-systems.

<b>HNAABS Refinement Annual Operating Cost</b>			
<b>Cost Item</b>	<b>Annual Cost (\$M)</b>	<b>Cost per Gallon</b>	
Electricity	\$ 3.38	\$	0.11
Natural Gas	\$ 7.34	\$	0.23
Hydrogen	\$ 0.70	\$	0.02
Water	\$ 0.16	\$	0.01
Waste Management	\$ 0.81	\$	0.03
Land Lease	\$ 2.03	\$	0.06
Maintenance	\$ 12.90	\$	0.40
Manpower	\$ 23.10	\$	0.72
<b>Total</b>	<b>\$ 50.42</b>	<b>\$</b>	<b>1.58</b>

Table 77. HNAABS refinement annual operating cost.

### 3. Cost of Intersystem Transport

An intersystem transport mode was required such that the HNAABS subsystems would easily receive the water and oil required for mass production. The cultivation system has a requirement to produce 60 Million gallons of green crude per year to be refined into bio-kerosene. This requirement drove a need of approximately 168 Million gallons of fluid each day to be pumped through the cultivation system. Intricate piping is required to transport the water to a series of photobioreactor fields co-located with extraction devices to separate algal mass and oil. Figure 113 shows a simple diagram of the intersystem transport showing the supply lines for the nutrients, CO<sub>2</sub>, and algae inoculates and the output lines for the extracted algae oils to be sent to refinement.

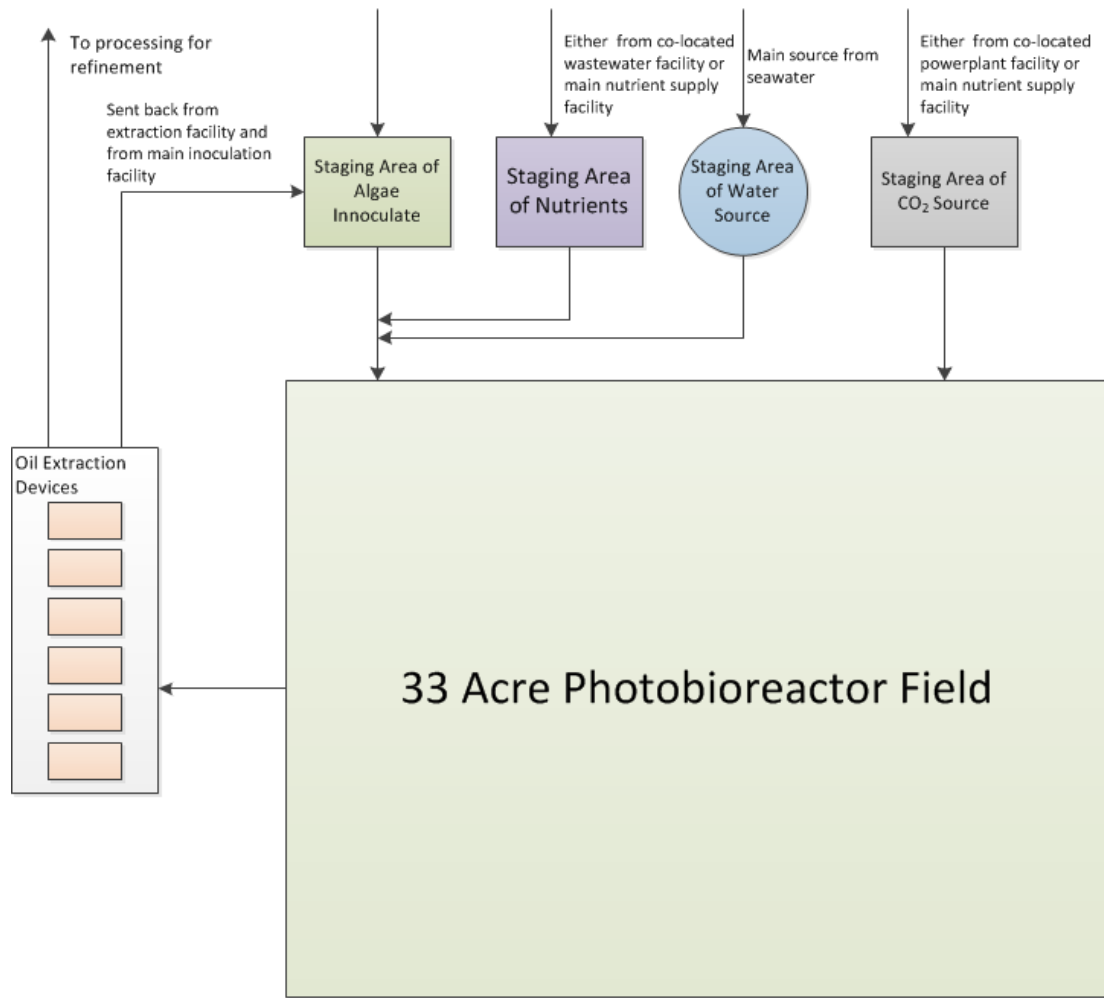

Figure 113. Intersystem transport of a single photobioreactor field cultivation system. The HNAABS configuration requires approximately 219 of these fields.

The transport system would begin with a well serving as the source of sea water to supply the entire cultivation system. Energy would be required to operate a pump station and elevator system that would lift the pumped water up a tower that will leverage gravity to begin water transfer. Downward water flow would facilitate transfer into PBR collectors. Internal valves regulate the flow water and the algae oil produced and transferred to a series of extraction tanks for the electroporation process to proceed. A number of tanks would be co-located with PBR fields to ease algal oil collection. Figure 114 shows a further expanded view of multiple photobioreactor fields with major supply and output lines between each set of fields. With the 12 fields shown, there would need to be approximately 18.25 sets of the fields shown to make up the total required 219

photobioreactor fields and associated 1,221 extraction units. The calculations to determine the total number of fields and devices are described in Section V.B.4.

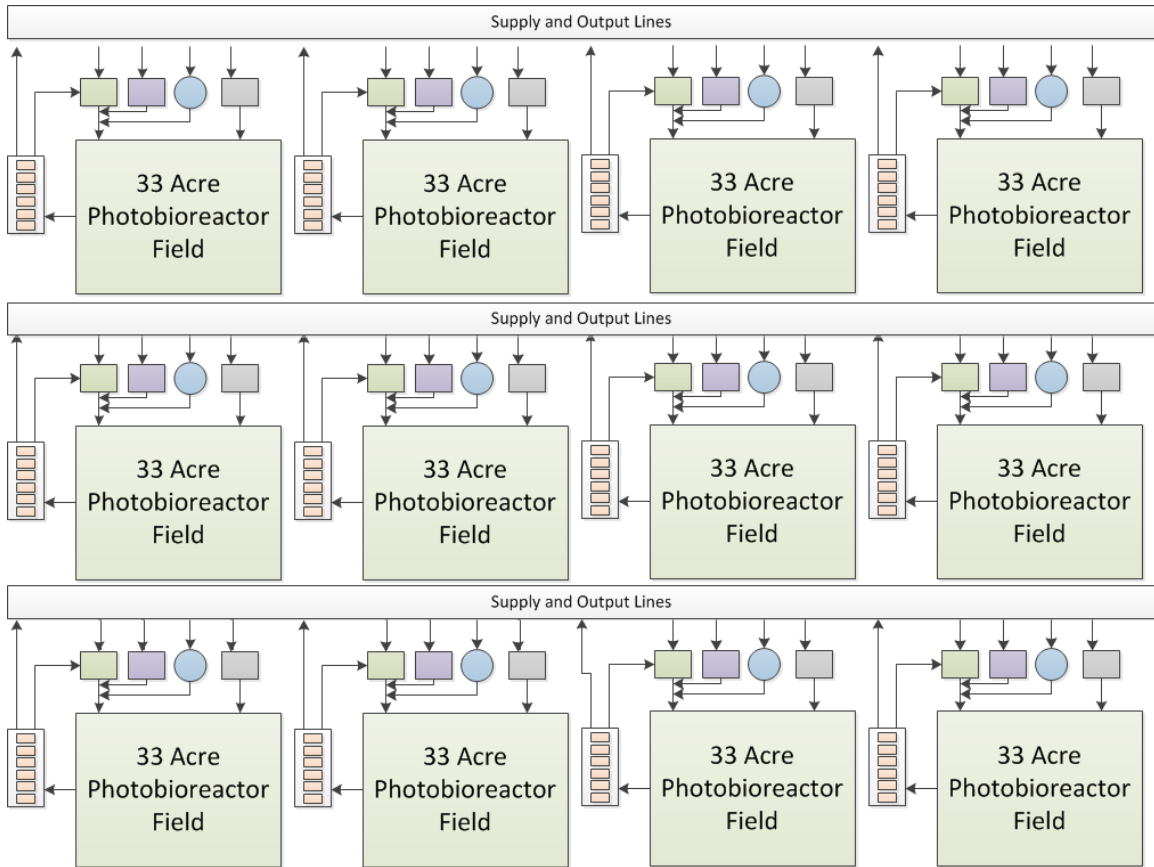

Figure 114. Twelve sets of photobioreactor fields with main supply and output lines shown. The HNAABS configuration requires approximately 18.25 of the sets shown to make up the total 219 photobioreactor fields and the 1,221 extraction devices.

Energy is required to perform the pumping and in-and -around transfer of sea water. An energy per foot rate was derived from data provided by The National Resources Defense Council (Cohen, Nelson and Wolff 2004). Approximately 1.46 kWh/acre-foot would be required to transfer the sea water up a vertical shaft. Assuming 10 feet of vertical movement 14.63 kWh are needed to transfer water for every acre-foot. Daily output of the 168 Million gallons was doubled to account for the water required to perform the harvesting functions and refill PBR tanks. After converting, 336 Million gallons was approximately 1,032 acre-feet which represents the total piping required to

transfer water in-and-around the cultivation system. The daily energy requirement of the in-and-around transfer was calculated as 15,088 kWh per day. Assuming daily, year round operations, the annual energy requirement 5.51 Million kWh. Applying a typical Hawaiian utility rate of \$0.35/kWh (Hawaiian Electric Company 2013), the annual electricity cost of the inter-transport system is approximately \$1.9 Million, and \$0.06/gallon.

Non-recurring material costs for purchasing pipes and pump station equipment were considered capital cost for the purposes of estimating HNAABS cost. Pipe infrastructure would be comprised of PVC pipes for high time performance during the cultivation system cycle. Approximately 1,032 acre-feet is the total piping required to transfer water throughout the cultivation system. This converted to about 44.9 Million cubic feet of piping required. Assuming unitized piping of 12 inches in diameter, approximately 993,000 feet of pipe would be required. The estimated purchase price of 12 inch diameter PVC pipe is \$2.50 per foot (Water Conservation Implementation Task Force 2004). The total material cost was calculated as \$993.3K. Valves were required approximately every 100 feet of pipe. Each valve had a unit procurement cost of \$769.35 (FlexPVC 2013). Based on the need of 397,343 feet of pipe, approximately 3,973 valves are required. The resulting estimated valve cost was \$3.1 Million. In addition to the pipes and valves, a pump station is required to extract sea water to commence the transport process. Pumps come with a unit cost of approximately \$2,000 per horsepower (hp) (U.S. Department of the Interior 2006). Assuming a well of approximately 200 feet in depth, 292 kW of energy would be needed to operate and elevate sea water (Cohen, Nelson and Wolff 2004). This equated to about 391.28 hp, which results in a unit price of \$783K for the pump apparatus to perform the transport function. The total capital cost for materials, valves, and pump station equaled \$4.2 Million.

#### **4. Cost of Growth System**

For the growth process the final configuration used a PBR. A PBR is a closed system equipment structure that provides and allows a controlled environment and decreases the amount of external influences, present in an open system. Since a PBR is a

closed and controlled system, the growth method of algae can be constrained to the requirements provided by the growers. Inputs into the system that need to be controlled, in addition to the purity of the culture itself, are CO<sub>2</sub> concentration and rate, water, temperature, exposure to light, culture density, pH levels, and mixing method.

*a. Growth Operations Cost*

(1) **Land Cost.** Land is considered a precious commodity in Hawaii. A mix of corporations, ranchers, state and federal government own the vast majority of land in Hawaii (J. Cooper 2012). Land needed for HNAABS would need to be leased on an annual basis. Land cost was a major component of the operations cost of the HNAABS subsystems.

The Cultivation and Cost teams researched PBR systems to uncover the technical baseline to calculate an operating cost. Much of the technical inputs in calculating these costs were based on 20,000 bbl/day production data scaled to meet HNAABS requirements for cultivation (Carlson, et al. 2010). The Cultivation Team derived algal oil production requirements of 60 Million gallons/year. Assuming non-stop production, this equated to approximately 164,384 gallons/day. This converts to 3,914 bbl/day assuming 42 gallons comprising a barrel of algal oil. Research dictates that 1,120 fields are required to reach a 20,000 bar/day production goal. Each field was approximately 33 acres in size (Carlson, et al. 2010). Each field had a capacity to produce 17.9 bbl/day. HNAABS calculated field requirements based on these technical derivations.

$$\# \text{ of Fields required} = \frac{3,914 \frac{\text{bbl}}{\text{day}}}{17.9 \frac{\text{bb}}{\text{day}}} = 219.2 \text{ fields}$$

The land leasing rate was derived from published rates for commercial land in Wahiawa, Hawaii. The average lease rate of commercial lots was approximately \$7,630 per acre (LoopNet 2010).

$$\text{Total surface area} = 219.2 \text{ fields} \times 33 \text{ acres} = 7,232.9 \text{ acres}$$

$$\text{Land Cost} = 7,630 \frac{\$}{\text{acre}} \times 7,232.9 \text{ acres} = \$55.2\text{M}$$

$$\text{Land Cost per Gallon} = \$55.2 \div 32 \text{ Million Gallons} = \$1.72/\text{gal}$$

(2) **Materials Cost.** Critical components of what will make HNAABS successful include successful management of raw materials and expedient ways of managing the power requirements of a PBR facility. Materials cost throughout this analysis was treated as an annual recurring cost. The *Algae to Alkanes* University of Pennsylvania report offered raw material requirements for a PBR system (Carlson, et al. 2010). These materials included nutrients, sea water, and CO<sub>2</sub>. These requirements were based on a 20,000 bbl/day production output requirement, then scaled down to meet HNAABS production requirements. A composite cost per second of output value was derived to be a ROM of about \$0.0007 per second utilizing similar PBR systems (Carlson, et al. 2010). Assuming constant around the clock HNAABS, the annual operations cost calculation was broken out.

$$\text{Single Field Materials Cost} = 0.0007 \frac{\$}{\text{sec}} \times 31,536,000 \text{ sec} = \$23.0\text{K}$$

$$\text{Total Growth Material Cost} = \$23,000 \times 219.2 \text{ fields} = \$5.0\text{M}$$

$$\text{Material Cost per Gallon} = \$5.0 \div 32 \text{ Million Gallons} = \$0.16/\text{gal}$$

(3) **Electricity Cost.** Electricity was another element of operations cost. Electricity is one of the most expensive commodities required in Hawaii and much programmatic risk comes to be play with this system. Hawaiian utility companies reported a base commercial rate of \$0.35 per kWh (kilowatt hour) for businesses (Hawaiian Electric Company 2013). Research identified an annual power requirement of approximately 257,000kWh for the PBR system to produce the needed output (Carlson, et al. 2010). The electricity cost for a PBR under HNAABS was calculated using applicable rates.

$$\text{Growth Electricity Cost} = 0.35 \frac{\$}{kWh} \times 257,000 \text{ kWh} = \$19.7\text{M}$$

$$\text{Electricity Cost per Gallon} = \$19.7\text{M} \div 32 \text{ Million Gallons} = \$0.62/\text{gal}$$

(4) **Maintenance Cost.** Maintenance was the final component of system operations cost that HNAABS considered in its cost analysis. This accounts for the scheduled and unscheduled maintenance that typically results from normal operations. Normally, maintenance costs are derived based on system reliability over time. In lieu of engineering data, a Cost Estimating Relationship (CER) was used. Approximately 1% of other operations costs represent the ROM estimate for the maintenance cost of a bio-kerosene production system (Dunford 2008). This percentage was applied to the sum of the land, materials, and electricity costs which equaled \$79.9M.

$$\text{Maintenance Cost} = 0.01 \times \$79.9\text{M} = \$800.0\text{K}$$

$$\text{Maintenance Cost per Gallon} = \$800.0\text{K} \div 32 \text{ Million Gallons} = 0.02/\text{gal}$$

$$\text{Total Operations Cost} = \$55.2\text{M} + \$5.0\text{M} + 19.7\text{M} + \$800.0\text{K} = \$80.7\text{M}$$

$$\text{Growth Operations Cost Per Gallon} = \frac{\$80.7\text{M}}{32\text{M gal}} = \$2.52/\text{gal}$$

***b. Growth Capital Cost***

The scale of the proposed growth system warrants acknowledgement of the hardware requirement needed to make it run. Researching the PBR system provided cost data points to estimate production hardware costs. The purchase price of PBR equipment would cost approximately \$45,000 per acre of system need (Oilgae 2008). Applying this rate to the land requirement of a PBR system shows a substantial financial commitment to the equipment purchase. A 40% rebate rate was assumed in this study. Many states offer rebate programs of up to 40% off of large industrial purchases of expensive equipment and services (Padosa 2009).

Production Equipment Cost = \$45,000/acre × 7,233 acres = \$325.5M

Cost with Rebate = \$325.5M - (\$325.5M × 0.40) = \$195.3M

*c. Growth Manpower Cost*

Manpower cost accounted for the labor associated with making PBR work in HNAABS. This labor cost included salaries and benefits of those laborers. Ideally, in estimating system manpower technical inputs included labor rates and engineering/labor headcounts assigned to the facility. Sources were identified with analogous system manpower data. The cost of manpower though could be considerable given the scope of PBR. Colocation with the extraction and dewatering facilities is ideal to offset labor costs. A share ratio of 30% was derived from the manpower requirements from each cultivation system.

Research concluded that the manpower requirement of an analogous system was approximate to 1 head per hectare (Acien, et al. 2010). This is the equivalent of 0.40 heads per acre. This calculation prior to the cost avoidance of colocation produces a requirement of about 2,927 laborers. This equates to about 13 workers per PBR field. To be explained in detail further, it was derived that 1-3 workers would be needed for the main extraction and dewatering processes. Thus it was concluded that 30% of PBR laborers at any time can be stationed elsewhere in the cultivation system. An average annual labor rate of \$46,000 was used from the Bureau of Labor Statistics in the Oil and Gas Subsectors (Statistics 2011). The growth system manpower requirement was calculated using this rate and share ratio.

$$\text{Manpower Cost} = 0.40 \text{ heads/acre} \times 7,233 \text{ acres} \times \$46,000 \times 0.30 = \$94.3\text{M}$$

$$\text{Growth Manpower Cost Per Gallon} = \frac{\$94.3\text{M}}{32\text{M gal}} = \$2.95 / \text{gal}$$

$$\text{Total Growth Cost} = \$80.7\text{M} + \$94.3\text{M} = \$175.1\text{M}$$

$$\text{Growth Cost Per Gallon} = \frac{\$175.1\text{M}}{32\text{M gal}} = \$5.47 / \text{gal}$$

## **5. Cost of Oil Extraction Process**

The Oil Extraction process is vital to the successful separation of oil to be refined into bio-kerosene and the biomass by-product to be sold to offset cultivation costs. This study found a trademarked process called Quantum Fracturing™ owned by OriginOil, Inc. of Los Angeles, CA (OriginOil, Inc. 2011). The process by which oil extraction occurred was known as electroporation. Electroporation is a method of lysing living cells to extract the cell's inner contents. It uses a series of electric pulses to create destructive forces on the cell walls. It works with many cell types, including algae cells. In this analysis of the oil extraction process chosen by HNAABS, electroporation and irreversible electroporation will be used interchangeably and refers to the chosen oil extraction process in general. The HNAABS Cultivation System will have a derived output capacity of about 60 million gallons of green crude per year, as described in HNAABS requirements in Appendix A.

### ***a. Oil Extraction Capital Cost***

An area of concern in this operation is the capital cost to support OriginOil's Quantum Fracturing™ process. An unofficial discussion with the OriginOil sales department gave some input to realistic numbers for capacity and startup cost. For a large capacity system around 750 liters per minute processing, the cost for licenses is \$60K per year with an estimated cost to build each unit on site as \$350K. Due to the scope of HNAABS extraction it was assumed that the licensing fee would be waived. Based on the volume of harvest (measured in gallons) needed to produce the required 60 Million gallons of green crude a year, a Quantum Fracturing™ facility would require

1,221 of OriginOil’s model 757 oil extracting devices. HNAABS output requirements drive hardware need. Equipment investment needed for a Quantum Fracturing™ system creates affordability risk. Likewise with the facilities risk, the unverifiable capital costs associated with OriginOil’s Quantum Fracturing™ drove some cost risk in the first year of operations for HNAABS. This will be an area of concern for decision makers going forward. The versatility of this process makes it ideal for extracting the oil content from newly cultivated algae without requiring extensive drying of the biomass product. However, it must be noted that the specific requirements of capital costs are more unknown and can drive additional programmatic risk.

As described in the previous section, the HNAABS Cultivation System has a derived requirement to produce 60 million gallons of green crude per year. On a year round daily basis, this equated to about 164,384 gallons of green crude per day. PBR’s bio-oil concentration percentage of 0.0978% indicated the amount of biomass water needed for oil extraction (Raleigh and Kuehnle 2009). This biomass water amount was calculated as 168.1 million gallons/day required for oil extraction. This rough calculation of annual biomass water is approximately 122.7 billion gallons required annually. Assuming an annual extraction capacity of 100.5 million gallons/year for each machine, the Team calculated the number of machines needed for oil extraction.

$$\text{Total \# of Extraction devices} = \frac{122.7\text{B} \frac{\text{gal of biomass}}{\text{year}}}{100.5\text{M} \frac{\text{gal of biomass (device capacity)}}{\text{year}}} = 1,221 \text{ devices}$$

$$\text{Production Equipment Cost} = 1,221 \text{ devices} \times \$350,000 = \$427.4\text{M}$$

$$\text{Cost with Rebate} = \$427.4 - (\$427.4 \times 0.40) = \$256.5\text{M}$$

***b. Oil Extraction Operations Costs***

(1) **Land Cost.** The methodology for calculating land cost remained consistent with previously mentioned sections. This land cost was treated as a recurring expense to lease land in Hawaii. Each device occupied approximately 67 square

feet with additional unused space. The total space requirement for oil extraction equaled 96,596 total square feet across the system. After converting to acres, the family of systems occupied 2.2 acres of land. This technical input with conversion factors were pivotal in calculating the cost of land the oil extraction system will occupy. The previously derived rate of \$7630 per acre was applied to the extraction system land requirement (LoopNet 2010).

$$\text{Land Cost} = 2.2 \text{ acres} \times 7,630 \frac{\$}{\text{acre}} = \$16.9\text{K}$$

(2) **Electricity Cost.** Estimating the electricity cost for the oil extraction system remained consistent in terms of marrying technical inputs with Hawaiian utility rates. Research sources indicated that oil extraction will expend approximately 0.000792 kWh/gal of throughput produced. Quantum Fracturing™ came with 95% extraction efficiency from algae, yielding 60 million gallons of oil that was created from 63.1 million gallons of the algae biomass (Algae Industry Magazine 2013). The weight of this oil was converted to 473.7 million lbs. Approximately 16.3% of the algae content is the original oil and that algal weight was calculated to be 2.9 billion pounds (Raleigh and Kuehnle 2009). Converting to gallons, this measurement was 111 Billion gallons of algae harvest per year. With this data the electricity requirements for oil extraction were calculated.

$$\text{Oil Extraction Electricity Cost} = 0.35 \frac{\$}{\text{kWh}} \times 0.00079 \frac{\text{kWh}}{\text{gal}} \times 111.0\text{B gal} = \$31.2\text{M}$$

$$\text{Oil Extraction Electricity Cost per Gallon} = \$31.2\text{M} \div 32 \text{ Million Gallons} = \$0.97$$

(3) **Materials Cost.** Driven by the assumption that yearly licensing fees for the electroporation equipment would be waived, there would be no need for additional material costs for the system.

(4) **Maintenance Cost.** For estimating the maintenance cost of the oil extraction system, the previously used operations cost CER was used. . This CER was used in the absence of task and reliability data tailored to estimate the level of repair

actions that normally take place in on oil extraction facility. Extraction system land, electricity, and materials cost sums up to \$31.2 Million.

$$\text{Oil Extraction Maintenance Cost} = 0.01 \times \$31.2 = \$311.7\text{K}$$

$$\text{Maintenance Cost per Gallon} = \$311.7\text{K} \div 32 \text{ Million Gallons} = \$0.01/\text{gal}$$

$$\text{Total Oil Extraction Operations Cost} = \$16.9\text{K} + \$31.2\text{M} + \$311.7\text{K} = \$31.5\text{M}$$

$$\text{Oil Extraction Operations Cost Per Gallon} = \frac{\$31.5\text{M}}{32 \text{ M gal}} = \$0.98/\text{gal}$$

*c. Oil Extraction Manpower Costs*

Manpower cost for the oil extraction system will leverage the benefits of colocation with the PBR fields. The manning rate of 0.040 heads per acre was applied to the estimated land requirements for the oil extraction system. Based on the derivation, approximately 1 laborer would be needed to monitor the entire extraction system. For additional conservatism, this requirement was doubled to 2 laborers to work in concert with PBR workers in monitoring the collocated processes. This assumes a great deal of integrated system automation. A labor rate from the Bureau of Labor Statistics was applied to make the calculation (Bureau of Labor Statistics 2013).

$$\text{Oil Extraction Manpower Cost} = 2 \text{ heads} \times \$46,000 = \$92.0\text{K}$$

$$\text{Total Oil Extraction Cost} = \$31.5\text{M} + \$92.0\text{K} = \$31.6\text{M}$$

$$\text{Oil Extraction Cost Per Gallon} = \frac{\$31.6\text{M}}{32 \text{ M gal}} = \$0.99/\text{gal}$$

**6. Cost of Dewatering**

Flash Drying was chosen by HNAABS as the major drying process for dewatering the wet biomass resulting from the oil extraction process. This process is ideal for evaporating surface moisture instantaneously, rendering dry biomass for the purpose of resale. Though this process is not required to produce algal oil in the HNAABS configuration, the cost estimating process included dewatering to calculate the benefit cost reselling the biomass as a commercial feedstock. The dewatering process utilizes machines called flash dryers, in which feedstock is suspended in an upward flow of the

drying medium, usually flue gas. These dryers are useful for these kinds of wet solids discharged from centrifuges, rotary filters and filter presses. A single operation combines the necessary mixing, and heat and mass transfer for drying a solid. As previously described in Section III.B.4.c.3, flash drying time is short, usually less than 3 seconds, and produces almost immediate surface drying.

*a. Dewatering Capital Costs*

Research successfully uncovered a ROM estimate for the unitized procurement cost of a dryer similar to the flash drying device in HNAABS. The dryers used in the dewatering process as researched by the University of Pennsylvania came with a catalog cost of \$700K per unit (Carlson, et al. 2010). Calculating the total number of dryers was the following step.

$$\text{Total \# of dryers needed} = \frac{17.867 \frac{\text{tons wet biomass}}{\text{day}}}{386 \frac{\text{tons (dryer capacity)}}{\text{day}}} \approx 47 \text{ units}$$

The \$700K per unit cost was applied to the 47 required units derived above in order to calculate the total production equipment cost for the drying process. The same industrial rebate of 40% was applied to these purchases to simulate large quantity sales.

$$\begin{aligned} \text{Dewatering Production Equipment Cost} &= \$700\text{K} \times 47 \text{ units} = \$32.9\text{M} \\ \text{Cost with Rebate} &= \$32.9 - (\$32.9 \times 0.40) = \$19.7\text{M} \end{aligned}$$

Similar to the oil extraction production equipment as detailed in Section V.B.4.a, all equipment costs should be treated as non-recurring investment costs. Future operational cycles of HNAABS would not require additional need of new equipment as the proposed configuration by this study is technologically modern.

**b. Dewatering Operations Costs**

(1) **Land Cost.** Land resources in Hawaii were an important element of the how the logistics of HNAABS would work. Each flash dryer occupies 6,728 square feet of space. Using the number of flash dryer units required that was calculated previously, the amount of space required is approximately 7.26 acres. Using the same derived land leasing rate the land cost requirements were estimated (LoopNet 2010).

$$\text{Dewatering Land Cost} = 7.26 \text{ acres} \times \$7,630 \text{ per acre} = \$55.4\text{K}$$

(2) **Electricity Cost.** Each flash dryer has an approximate power requirement of 432 kWh (ALSTOM Power Inc. Air Preheater Company 2013). Assuming around the clock operations, there is a power requirement per day of 10,368 kWh per day for each dryer. Applying this power rate to the other primary derivations of the dewatering process, the total electricity cost can be calculated. Once again, HECO's power utility rate was used to generate cost (Hawaiian Electric Company 2013).

$$\begin{aligned} \text{Dewatering Electricity Cost} &= 10,368 \frac{\text{kWh}}{\text{day}} \times 47 \text{ units} \times \$0.35 \text{ kWh} \times 365 \text{ days} = \$63.1\text{M} \\ \text{Dewatering Electricity Cost per Gallon} &= \$63.1\text{M} \div 32 \text{ Million Gallons} = \$1.97/\text{gal} \end{aligned}$$

(3) **Materials Cost.** Heating the low-pressure air was imperative to the dewatering process. This air injects into the lower drying chamber through a series of ducts and creates the high velocity flow of gas that dries the biomass. This heating process is done via fuel oils which generates the heat source for this process. Each drying process will require approximately 55.8 Million Btu per hour of operation (ALSTOM Power Inc. Air Preheater Company 2013). One barrel of fuel oil provides about 5.8 Million Btu of heat. After converting to an annual requirement of fuel oil, the dewatering process would need 84,569 barrels per year. The average cost of fuel oil per barrel is currently about \$131.46 per barrel (Dart 2012), which equated to \$11.1 Million

annually. The HNAABS Team converted to a daily requirement to scale down to the operations that this project proposed.

$$\text{Dewatering Materials Cost} = \$30,459 \text{ per day} \times 365 \text{ days of operation} = \$11.1\text{M}$$

(4) **Maintenance Cost.** O&M cost for the dewatering process was calculated using the same methodology as described previously in Section V.B.3.a.2. Once again in an attempt to account for needed system maintenance, the same operations cost estimating relationship was used to calculate O&M cost. The land, electricity, and materials cost of the flash drying system sums up to about \$74.2 Million

$$\text{Dewatering Maintenance Cost} = \$74.2\text{M} \times 0.01 = \$742.3\text{K}$$

$$\text{Dewatering Maintenance Cost per Gallon} = \$742.3\text{K} \div 32 \text{ Million Gallons} = \$0.02/\text{gal}$$

$$\text{Total Dewatering Operations Cost} = \$55.4\text{K} + \$63.1\text{M} + \$11.1\text{M} + \$742.3\text{M} = \$75.0\text{M}$$

$$\text{Dewatering Operations Cost Per Gallon} = \frac{\$75.0\text{M}}{32\text{M gal}} = \$2.34/\text{gal}$$

*c. Dewatering Manpower Costs*

Manpower cost was calculated using the same manpower requirement rate of 0.40 heads per acre (Acien, et al. 2010). The drying system proposed by HNAABS assumed 47 dryers will occupy 7.3 acres. Approximately 3 workers will be needed to man the dewatering system. This requirement was doubled to account for workload relief of the individuals manning the system. Keeping the labor rate assumption consistent with the other cultivation subsystems, the manpower cost was calculated.

$$\text{Dewatering Manpower Cost} = 6 \text{ heads} \times \$46,000 = \$276.0\text{K}$$

$$\text{Dewatering Manpower Cost Per Gallon} = \frac{\$276.0\text{K}}{32\text{M gal}} = \$0.01/\text{gal}$$

$$\text{Total Dewatering Cost} = \$75.0\text{M} + \$276.0\text{K} = \$75.2\text{M}$$

$$\text{Dewatering Cost Per Gallon} = \frac{\$75.2\text{M}}{32\text{M gal}} = \$2.35/\text{gal}$$

## **7. HNAABS Cultivation Life Cycle Cost**

The primary affordability metric of HNAABS is the Free On-Board cost per gallon of bio-kerosene produced. The Cultivation Free On-Board Cost per gallon took in the total annual operating cost of the system and dividing by the requirement output level. The Free On-Board cost of fuel calculated to approximately \$8.87 per gallon for the Cultivation system alone. The cost per gallon of the required systems for growth and oil extraction, omitting the flash drying process, is approximately \$6.52 per gallon. The affordability target of HNAABS developed by the Risk/Requirements Team was \$3.00 per gallon of bio-kerosene produced. When compared to the affordability target, the process to cultivate bio-oil is unaffordable. System drivers include land requirements and electricity. Further research studies or state or federal credits for these items could offer more affordable solutions. Affordability is a key metric to determine program success, however, technical and logistics requirements drive feasibility.

## **8. Cost of Refinement Process**

A cost analysis of the Refinement process, where the green crude is converted to aviation fuel was also conducted. The cost analysis assessed the capital costs that would be required to build the Refinement facility as well as the annual operating costs of the facility. The annual operating costs were categorized, and the individual contributions to the final dollar per gallon cost of the HNAABS produced bio-kerosene were calculated. This process allowed the cost drivers of the refining process to be identified. By identifying the critical cost items, the HNAABS Team was able to gain insight on the

feasibility of meeting the overall HNAABS objective of producing 32 million gallons of aviation bio-kerosene at a cost of \$3 per gallon.

*a. Refinement Capital Costs*

The capital costs required for the HNAABS were estimated largely through comparative methods as described in Section V.B.3.b. An existing refinery could be retrofitted with the capability to refine bio-kerosene; a new refinery could be built that focuses solely on bio-kerosene, or a hybrid alternative with the capability to produce bio-kerosene and petroleum products could be considered. For any of these options, the capital costs would be invested up front, and the refinery would recoup the cost paid over time as the bio-kerosene process became profitable. For this reason, the capital costs of a bio-kerosene refinement facility discussed earlier are not included in any of the dollar per gallon estimates that follow.

*b. Refinement Operations Costs*

To build a cost estimate of the refining process, the HNAABS Refinement system architecture, as described in Section III.C, was examined and costs were assigned to the various inputs and outputs. The refinement system was estimated to operate at approximately \$50.4M annually. Major cost drivers include refinery maintenance, labor, and natural gas costs. The free on board cost of energy contribution was approximately \$1.58 per gallon.

(1) **Energy Cost.** The energy costs of the refining process are not quite as high as one might expect, contributing less than labor and roughly as much as maintenance to the refinery expenses. This energy cost includes the cost of electricity as well as natural gas. As stated previously, refineries can generate up to 60% of their energy requirements internally by burning off byproducts of the green crude or recycling heat. The two main sources of external energy purchased by refineries are electricity and natural gas. In 2008, 146 U.S. refineries, with a total capacity of 17.23 million barrels of crude petroleum per day, purchased external energy in the forms of natural gas (710,500,000,000 cubic feet), electricity (42,682,000,000 kWh), coal (86,000 pounds) and steam (98,769,000,000 pounds) according to (DeHaan 2010). Neglecting the steam

and coal (only 1/37<sup>th</sup> of the total expense), one could divide the total costs for natural gas and electricity by the total number of barrels these refineries processed to estimate the average cost of each fuel source per barrel of crude during the refining process. In all, estimated energy expenses for refining contribute about \$0.14 per gallon (DeHaan 2010) to the cost of refining one barrel of crude oil (based on the 2008 prices of \$0.07 per kWh of electricity and \$9.58 per 1000 cubic feet of natural gas).

For HNAABS, one could assume similar proportions of natural gas and electricity will be required by the refinery. To estimate the cost of electricity the HNAABS refinery would require, the average kWh per barrel from above was multiplied by the 3900 barrels per day the HNAABS system will process and multiplied by the \$0.35 per kWh price of electricity on Hawaii (Hawaiian Electric Company 2011). The same process was used to calculate the natural gas requirements of the refinery, in conjunction with the 2011 average price of natural gas in Hawaii (\$45.63 per 1000 cubic feet) (U.S. Energy Information Administration 2013). This yielded a total energy cost for refining of \$0.34 per gallon of green crude based on Hawaiian prices in 2011.

(2) **Materials Cost.** The hydrogen contribution to the cost estimate was based on a need of 550 cubic feet of hydrogen per barrel, as described in Section III.C.5.a. It is estimated that commercially produced hydrogen that is consumed on site in a facility such as an oil refinery can cost on the order of \$0.32 / lb. (U.S. Department of Energy 2002). Converting units and multiplying by the 3900 barrels per day processed by HNAABS over the 365 days in a year will provide the annual cost of hydrogen as approximately \$700K annually. The annual cost can be divided by the 32 million gallons of HNAABS produced fuel to get the per gallon contribution of hydrogen used during the refining process to the overall cost of bio-kerosene. The materials cost per gallon was calculated as \$0.02 per gallon, accounting for the hydrogen levels needed.

The water requirements described in Section III.C.5.b were combined with the utility rate for large businesses on Hawaii, which is \$2.31 per 1000 gallons of fresh water, to yield a total annual water cost of \$164,414. An estimate of 50 gallons per barrel of green crude was used in the final calculations. The Water Utilization section, Section III.C.5.b, specified a requirement for 75 gallons of water per barrel of

crude oil processed, but the amount HNAABS would require to be purchased was set at 50 gallons to account for HNAABS recycling efforts throughout the Cultivation and Refinement systems. The final annual water cost was calculated as approximately \$160K with a cost of \$0.01 per gallon.

Waste management numbers are relatively subjective compared to other items due to the constantly changing definitions of hazardous wastes as compared to non-hazardous wastes. A study conducted in 2002 by the California Environmental Protection Agency surveyed 17 petroleum refineries on 23 sites, and categorized the hazardous waste produced at each facility into two categories. Category A waste referred to streams that could be discharged via sewer systems and processed by publicly owned water treatment facilities, while all other waste streams were labeled Category B wastes. In the most recent surveys, many refineries are reporting zero Category A wastes and claim that the wastewater produced is non-hazardous and does not qualify as Category A (Schwarzenegger, et al. 2006). Additionally, refineries have made great strides in reducing the amount of Category B waste produced. Not only have refineries greatly reduced the amount of Category B waste produced (Schwarzenegger, et al. 2006), new methods of recycling heavy metals in the waste have turned what was once a waste disposal cost into an economically viable way of recovering valuable metals (Liang 2005).

In 1996, costs for disposing of petroleum wastes ranged from \$125 to \$750 per ton (Schwarzenegger, et al. 2006). Based on the trend of reduced Category B wastes produced at refineries and the progress made in recycling heavy metals in those wastes, HNAABS used a figure of \$500 per ton to estimate the disposal costs for hazardous wastes (Lawrence Berkeley National Laboratory 2013). Coupling this price with the fact that in 2002 petroleum refineries were producing about 0.08 percent hazardous waste per input volume of crude oil (Schwarzenegger, et al. 2006), one can use the input of the HNAABS refinery, 3900 bbl./day green crude, to calculate the amount of hazardous waste the HNAABS refinery will need to dispose of and the associated costs. In this case, 3900 bbl. per day equates to roughly 0.45 tons of waste per day, assuming 7 barrels per ton density of the green crude. Annually, this comes out to 163 tons of

hazardous waste, which can be disposed of at a cost of \$813,000. The final contribution is roughly one quarter of a cent per gallon towards the final cost of the HNAABS produced fuel. This demonstrates that while safe disposal of refinery waste may be an environmental or public relations concern for the project, it is not a driving factor in the economic feasibility of the HNAABS system.

(3) **Land Lease.** The lease rate of \$25,000 per hectare was used to calculate the cost of the land needed for refinement. A total of 10.1 hectares, (or 25 acres) will be required for the HNAABS Refinement facility. Multiplying the lease rate by the number of hectares required and dividing by the 32 million gallons of HNAABS fuel produced annually yields approximately \$0.06 per gallon. Thus, based on how scarce a commodity land is on an island state, land leasing costs for the refinement system are not exorbitant.

(4) **Maintenance.** Research has shown that refinery maintenance costs are related to the sophistication of the facility itself. The *Algae to Alkanes* research study identified a CER assuming 4.5% of Capital Cost as a ROM estimate for maintenance cost of a refinery (Carlson, et al. 2010). The cost per gallon contribution of the maintenance cost equaled about \$0.40 per gallon annually. Maintenance costs can range from 3.8% of the investment cost (Van Gerpen 2008) of the plant to as much as 6.0% (U.S. Energy Information Administration 2012). The HNAABS team chose to use the same 4.5% factor as the University of Penn team, which is central to the previously mentioned range of values. For this calculation, the capital investment cost was set at \$285.6 million, as explained in section III.C.7.b. This places maintenance as the second largest cost driver for refinement operations; even more costly than energy expenditures.

### ***c. Refinement Manpower Costs***

Manpower makes up the largest cost contribution for the refinement phase of the HNAABS. Based on an estimate of 88 employees being required to maintain 24/7 operations making an average wage of \$30 per hour, the labor for refinement operations would cost approximately \$0.72 per gallon for each of the 32 million gallons of aviation fuel produced. The refinery could operate with as few as 65 employees, which would

drop the cost per gallon to only 53 cents per gallon. Items that will drive varying manning levels will be refinement system size and capacity levels. In either case, this would remain the driving factor for the cost of refining HNAABS produced fuels.

## **9. HNAABS Refinement Annual Operating Cost**

Combining all annual continuous costs for the refinement process, the HNAABS aviation oil will cost \$1.58 per gallon for the refinement process alone. Previous attempts were made at refining an algae oil based alternative for DoD use. The Defense Advanced Research Projects Agency (DARPA) performed a smaller scale production process with a refinement cost of less than \$3.00 per gallon for a 50-50 petroleum blend. Larger scale facilities capable of producing 50 million gallons were slated to be established in 2011 (Goldenberg 2010). The HNAABS cost projection is driven largely by the labor costs, and secondarily by maintenance and energy costs. For example, the difference between running the HNAABS refinery with 88 employees (HNAABS high estimate) and 65 employees (HNAABS low estimate) is nearly \$0.16 cents per gallon (\$1.58 vs. \$1.42). To put this cost savings into perspective, that is 1.5 times the amount the refinery will spend yearly purchasing electricity from outside sources. Finding efficiencies in the areas of labor and maintenance for the refinement process will have the greatest effect when attempting to produce competitively priced bio-kerosene.

## **10. Cost Benefit Analysis**

Opportunity existed in offsetting Cultivation system cost. This opportunity was driven by leveraging commercial need of HNAABS byproduct. Flash Drying as a dewatering solution was analyzed as part of the AoA process in section III.B.4.c.3. This alternative ensured that the dried biomass met qualification standards for resale as an animal feedstock. Resulting from the AoA, Flash Drying scored high in the areas of cost and performance; however, it was deemed unnecessary for the direct bio-kerosene output required by HNAABS. This biomass is commonly resold as animal feed or as raw material for the production of ethanol. Current feedstock commercial resale value fluctuates greatly as predicated by nutritional content and market demand. An average price of approximately \$0.03 per pound was used to estimate the resale value of the dry

biomass (Garofalo 2011). This rate was considered quite conservative with documentation supporting a wide range of feedstock prices. (Flammini 2011) . Assuming economic demand for animal feedstock, this indicated opportunity to offset some of the operational costs of HNAABS. The Cost Team applied this feedstock sale value to the HNAABS's derived amount of dry biomass to sell. Based on the bulk of algae weight approximately 2.25 Billion pounds of aqueous biostock would be dried yearly assuming 365 days of operating scale. The benefit cost of biomass resale was calculated. HNAABS heavily leverages the resale of the dry algal mass to help achieve a reasonable cost target.

$$\begin{aligned} \text{Benefit Cost of Biomass Resale} &= 2.25\text{B lbs dry biomass} \times 0.03 \frac{\$}{\text{lb}} = \$68.2\text{M} \\ \text{Resale Cost per Gallon} &= \$68.2\text{M} \div 32 \text{ Million Gallons} = \$2.13/\text{gal} \end{aligned}$$

Cost drivers in the Flash Drying process included the procurement of production equipment as investment cost and the cost of electricity. A great level of risk is being absorbed in this benefit calculation. The assumptions driving the scope of HNAABS could be considered slightly overstated when compared to industrial standards. The benefit amount reported by this study assumes a theoretical value of the biomass being produced by the cultivation system and assumes an optimized environment for the sale of dry biomass as a feedstock. Future studies could consider a system scale (operating hours) more analogous to the industrial standards of today. Lessening the operating assumptions in HNAABS from year round continuous operations will drive down annual operating costs.

The U.S. Department of Energy also had legislation in place to assist bio-kerosene producers. Biodiesel producers or blenders were eligible for an income tax credit of \$1.00 per gallon of biodiesel produced with a cap of \$10,000,000 annually (U.S. Department of Energy 2013). In order to receive the credit, the final product was required to meet ASTM (American Standard Test Method) specifications. It is not yet known whether the algae based bio-kerosene HNAABS is producing would be eligible to receive this tax credit; however, it was definitive that programs exist to slightly offset costs. This tax credit approximates to \$0.31 per gallon saved from the Free On-Board cost metric.

Net Annual HNAABS Cost Benefit = \$68.2M + \$10.0M = \$78.2M

Net Benefit Cost per Gallon = \$78.2M ÷ 32 Million Gallons = \$2.44/gal

### 11. Budget and Resource Analysis

HNAABS resource requirements would be pivotal to the offices of the U.S. Navy Resource entities such as OPNAV. In order for decision makers to digest the appropriate amount of funding a project such as this requires, an educated and accurate estimate of resource requirements is needed. Major annual operational resources needed to make HNAABS work included: energy, water utilization, and land, as described in Table 78.

Approximate HNAABS Annual Operating Resource Requirements	Energy Requirement (kWh-Millions)	Water Utilization (Gal-Millions)	Land Requirement (acres)
<b>Cultivation</b>	<b>331.0</b>	<b>110,269.6</b>	<b>7,242.4</b>
Transport	5.5		
Growth			
Photobioreactor	56.3		7,232.9
Oil Extraction			
Quantum Fracturing	89.0		2.2
Dewatering			
Flash Drying	180.1		7.3
<b>Refinement</b>	<b>9.7</b>	<b>71.2</b>	<b>25.0</b>
<b>Total</b>	<b>340.6</b>	<b>110,340.8</b>	<b>7,267.4</b>

Table 78. HNAABS annual operating resource requirements.

The size of the proposed cultivation system is derived by the technical capacity limitations and the output requirement driven by HNAABS' 32 Million gallon bio-kerosene goal. The need of more than 200 PBR fields to effectively produce the Navy's desired need is a substantial driver of HNAABS logistics footprint. Spreading out output levels of HNAABS over multiple years could result in reductions of annual resource requirements. This relies on stakeholder input of accepting 32 million gallons of bio-kerosene over 2-3 years vice annually.

Energy was considered another vital commodity in Hawaii, such that the state has recorded some of the highest energy costs in the nation. What drove high energy rates on the islands is the nature by which Hawaii produces its energy, via burning fuel oil (Hawi'i Clean Energy Initiative 2013). Energy Return on Investment (EROI) was a metric used in this study to evaluate the effectiveness of the proposed bio-kerosene as an energy source for Naval aircraft. The EROI evaluates the potential energy available in a unit of fuel divided by the energy required to make that unit. HNAABS was estimated to require about 340.6 Million kWh of electricity. Research shows that a refined bio fuel offers 44.8 MJ/kg of energy as a theoretical bio fuel utilization rate (Savage 2011) Converting the energy rate was necessary to develop an equitable comparison.

$$44.8 \frac{\text{MJ}}{\text{kg}} \times 0.126 = 5.645 \frac{\text{kWh}}{\text{lb}}$$

$$1 \text{ lb} = 0.15 \text{ gal of jet fuel}$$

$$5.645 \frac{\text{kWh}}{\text{lb}} \times \left( \frac{1 \text{ lb}}{0.15 \text{ gal}} \right) = 38.6 \frac{\text{kWh}}{\text{gal}}$$

Based on the scaled output of HNAABS, a bio-fuel with a theoretical energy value of 38.6 kWh/gal should produce approximately 1.24 Billion kWh of energy. This data allowed for a simple calculation of EROI. This is a key finding that concludes that approximately 27.6% of the fuel energy produced by HNAABS is consumed in the production process.

$$\text{EROI} = \frac{1,236 \text{ Million kWh (theoretical value)}}{341 \text{ Million kWh (HNAABS value)}} = 3.6$$

## 12. Cost Analysis Conclusions and Recommendations

The annual operating cost of HNAABS was a ROM calculation derived from an abundance of research from academic studies and widely available commercial data. Through research, the group gathered the technical and programmatic baseline to

calculate cost. Some of the barriers that the HNAABS Team came across included the availability of high fidelity data due to private, proprietary nature and the need to scale research data down to meet HNAABS configuration. Both of these issues drove ground rules and assumptions that can affect exact fidelity. The data in Table 79 is a representation of the Team’s best approximation of the annual operating cost and Free On-Board cost of bio-kerosene. HNAABS would operate at an approximate cost of \$256M annually in producing 32 Million gallons of bio-kerosene to support naval fleet operations. With cost benefit initiatives, this system would approximately operate at a Free On-Board cost of \$8.00/gal. Table 79 details the operating cost only, precluding the capital cost of production equipment.

<b>HNAABS Annual Operating Cost</b>			
		Operating Cost (\$K)	\$/Gallon Contribution
Cultivation	\$	283,974	\$ 8.87
Benefit	\$	(78,152)	\$ (2.44)
Refinement	\$	50,420	\$ 1.58
<b>Total Annual Operating Cost</b>	<b>\$</b>	<b>256,242</b>	
<b>Free On Board Cost of Fuel (\$/Gallon)</b>			<b>\$ 8.00</b>

Table 79. HNAABS annual operating cost.

*a. Cost Excursions*

The Free On-Board cost per gallon was a vital metric by which decision makers can gauge affordability. The Risk/Requirements Team established an Operating Cost KSA of \$3.00/gal as the primary affordability goal. The logistics of Hawaii (land, natural resources, utilities, et.) and technical maturity of processes accommodate technical feasibility. However, based on the assumptions and source data collected the HNAABS system is unable to reach this affordability target. The need for excursions of operating and ownership cost of the HNAABS system can assist the stakeholders in developing a cost range for the proposed system.

<b>Approximate HNAABS Cost Excursions (\$/gal)</b>	<b>Current Estimate</b>	<b>Excursion 1</b>	<b>Excursion 2</b>
<b>Cultivation</b>	\$ <b>6.43</b>	\$ <b>6.52</b>	\$ <b>21.29</b>
Transport	\$ 0.06	\$ 0.06	\$ 0.19
Growth	\$ 5.47	\$ 5.47	\$ 11.58
Oil Extraction	\$ 0.99	\$ 0.99	\$ 9.00
Dewatering	\$ 2.35	\$ -	\$ 2.97
Net Benefit	\$ (2.44)	\$ -	\$ (2.44)
<b>Refinement</b>	\$ <b>1.58</b>	\$ <b>1.58</b>	\$ <b>1.58</b>
<b>Total</b>	\$ <b>8.00</b>	\$ <b>8.10</b>	\$ <b>22.87</b>

Table 80. Approximate HNAABS cost sensitivities (\$/gal).

(1) **Excursion One.** Excursion one represents the annual operating cost of HNAABS of the core required subsystems to produce the bio-kerosene requirement. The primary configuration of HNAABS includes the PBR and electroporation processes only. Electroporation doesn't require drying prior to extracting oil from the algae slurry. The need for dewatering via flash drying was included in the main estimating process to project the benefits of byproduct sales. This excursion is practical such that it points out the estimated value of the dry biomass and the investment cost needed to perform the work. The estimated return on investment of flash drying is approximately \$0.09 per gallon. Knowing this, the stakeholders can assess the value of implementing flash drying as a dewatering mechanism. Though the overall value of wet biomass is considerably low, additional risk in this excursion would include the financial cost and environmental impacts of wet biomass disposal. Though wet biomass waste streams exist, disposal is difficult and proves detrimental to the environment. The Refinement process was made up of largely fixed costs with very little opportunity of cost reductions via scale limitations.

(2) **Excursion Two.** Assumptions behind Excursion two take into account the inclusion of land and capital cost for production equipment. Rationale for the inclusion of these elements is to simulate the Year 1 cost of HNAABS. This includes the required funding for purchasing production equipment to make HNAABS work.

In the budget uncertainty facing modern day government acquisition programs, it is important for acquisition professionals to identify opportunities to save cost. A common strategy utilized in government acquisitions involves encouraging open competition to mitigate investment costs. Potential bidders in the industry receive proposals for military systems. High levels of activity in industry can result in more competitive pricing.

In conclusion, HNAABS faces some affordability risk driven by electricity and land requirements of the cultivation system. Tradeoffs in the areas of electricity and land requirements can be made to offset operations cost. Business opportunity based on selling byproducts may also result in meager cost benefits to production and refinement systems. Emphasis must be placed on system scope, size, and requirements derivation in order to directly affect annual operational cost.

### **C. CONCLUSIONS AND FURTHER RESEARCH**

The likelihood that Hawaiian biofuel will be cost competitive with traditional petroleum fuel sources is very low at this time. The base material cost of biofuel production still exceeds petroleum fuels for industrial quantities. The cost of developing these resources in one of the most expensive states in the country further exacerbates this problem. Production of biofuel is technically feasible on an industrial scale. States offering tax and other business incentives are seeing the initial commercial forays into biofuel production, as evidenced by the formic acid plant in Geismar, Louisiana (Biofuels Journal 2008). If Hawaii is going to attract green business, the state must have a climate conducive to high risk business ventures. Land costs, prohibitions against commercial application of genetically modified agriculture products, and higher than average energy costs create a barrier to businesses. The closure of the Tesoro refinery does not bode well for the Hawaiian energy business.

The OMEGA system has a low technical maturity, so production representative information is currently not available. As NASA continues to develop the technology, it will mature and possibly offer a growth alternative that does not require expensive land resources. Additionally, the development of Quantum Fracturing™ in the last few years

gives the potential for another drop in biofuel production costs, though this alone does not appear to be enough to make bio-kerosene a commercially viable product.

Heterotrophic bioreactors offer further potential for both reduced cultivation growth space and greater oil density per kg of algae. Whereas the *Chlorella* modeled in this paper is 16.3% oil by weight, a custom strain of algae capable of heterotrophic growth could be designed to have a significantly higher oil/weight density. This would dramatically reduce every step of the algae cultivation process; an algae strain with 30% oil by weight would require approximately half the infrastructure of the HNAABS design. A significant fraction of the cost is tied up in the cultivation and dewatering of the algae and the maturation of this technology may hold the potential to unlocking biofuel feasibility.

THIS PAGE INTENTIONALLY LEFT BLANK

# APPENDIX A. PERFORMANCE SPECIFICATION

## A. SCOPE

### 1. Scope

This specification defines the requirements for the Hawaii Naval Aviation Biofuel System (HNAABS) as derived by the Naval Postgraduate School (NPS) Cohort 311-113A.

### 2. System Description

This specification shows all requirements necessary to produce algae derived bio-kerosene that will be used as a blend stock to produce aviation grade turbine fuel. This specification will not address the requirements necessary to transport the finished algal bio-kerosene. Figure 115 shows the system as described in this specification.

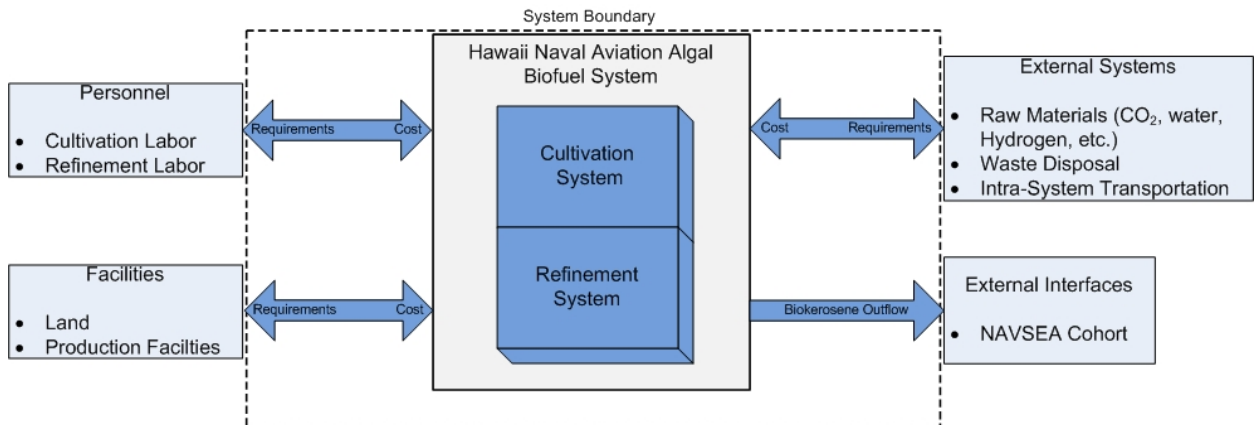

Figure 115. Proposed HNAABS system of systems diagram, showing key interfaces.

## B. APPLICABLE DOCUMENTS

MIL-DTL-5624U

Detail Specification Turbine Fuel, Aviation, Grades JP-4 and JP-5

MIL-DTL-83133H

Detail Specification Turbine Fuel, Aviation, Kerosene Type, JP-8 (NATO F-34), NATO F-35, and JP-8+100 (NATO F-37)

## **C. REQUIREMENTS**

### **1. General**

#### *a. System of Systems*

The algal biofuel system of systems shall consist of a cultivation system and refinement system.

#### *b. Throughput*

The HNAABS shall be capable of producing a minimum of 32 million gallons of bio-kerosene type aviation grade turbine fuel in accordance with turbine fuel specifications MIL-DTL-5624U and MIL-DTL-83133H.

#### *c. Operational Availability*

The HNAABS shall have a greater than or equal to 90% (Ao) Operational Availability. Operational availability for this system is defined as  $Ao = \frac{MTBM}{MTBM + MDT}$ . Mean Time Between Maintenance (MTBM) & Maintenance Downtime (MDT) as shown in Figure 116.

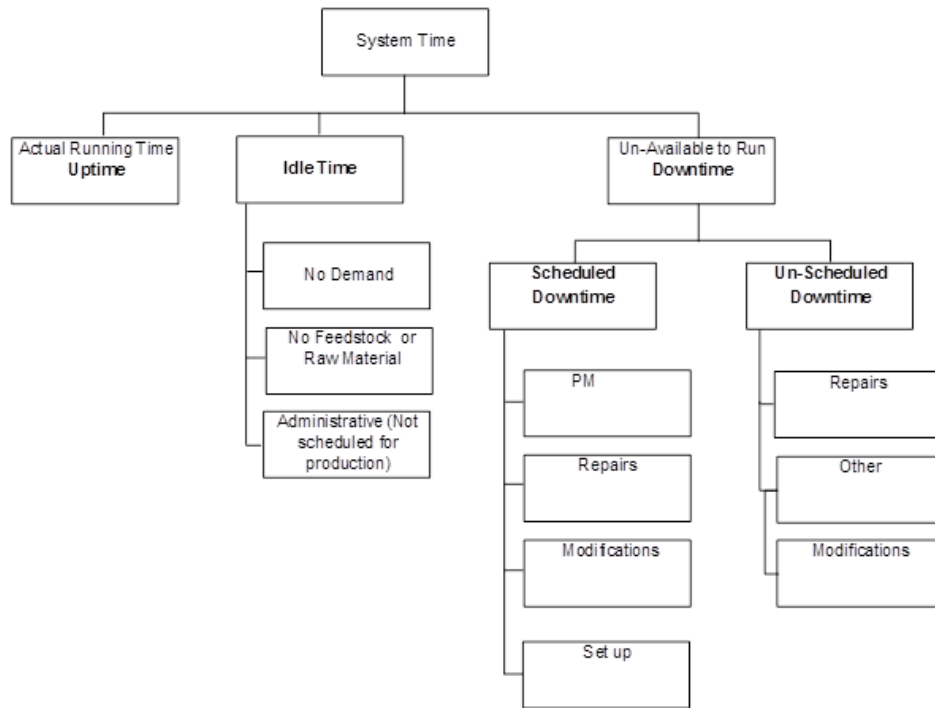

Figure 116. System time definition diagram.

(1) **Subsystem Operational Availability.** Cultivation and Refinement, working in series, shall have individual  $A_0$  greater than or equal to 95% to meet the system level 90% requirement.

Each system shall have less than or equal to 436 hours of scheduled maintenance downtime a year during a 24/7 operation schedule.

436 hours equates to 2 ½ weeks of maintenance downtime and 8,300 hours or 49 ½ weeks a year for production.

**d. Free On-Board Fuel Cost**

The HNAABS shall meet the Free On-Board production cost of \$3/gal annually.

***e. Regulatory Constraints***

The HNAABS system of systems production shall meet all local, state, and federal environmental regulations.

(1) ***Algae Strain Selection.*** The subsystem shall utilize an algae strain that is not considered invasive or prohibited.

(2) ***Air Pollution.*** The subsystem shall minimize all waste air emissions identified by the International Petroleum Industry Environmental Conservation Association (IPIECA) including combustion products and fugitive emissions of volatile organic compounds.

(3) ***Effluent Levels.*** The subsystem shall meet or exceed all effluent limitations and standards set by governing environmental agencies.

***f. Cultivation Subsystem Requirements***

(1) ***Production.*** The subsystem shall produce a minimum of 1.5 million gallons of green crude per week.

(2) ***Biostock Yield.*** The yield shall be a substantial amount capable of meeting the production minimum of 1.5 million gallons per week.

(3) ***Biomass Waste Storage.*** The subsystem shall have waste storage capacity capable of meeting the green crude production minimum of 1.5 million gallons per week.

***g. Refinement Subsystem Requirements***

(1) ***Production.*** The refinement subsystem shall be capable of refining a minimum of 800,000 gallons of green crude per week.

(2) ***Product (Bio-Kerosene) Quality.*** The quality of the bio-kerosene product shall be adequate for blending with aviation grade turbine fuel in accordance with specifications MIL-DTL-5624U and MIL-DTL-83133H.

***h. Logistics***

The HNAABS shall be supported in accordance with Defense Acquisition Guidelines provided by DoDD 5000.01 and DoDI 5000.02. The HNAABS shall develop

and implement logistics strategies that optimize total system availability while minimizing cost and system footprint. Trade-off decisions involving cost, useful service, and effectiveness shall be considered for all the resource requirements provided in this section including the best use of public and private sector capabilities through government/industry partnering initiatives, in accordance with statutory requirements.

- Manpower
- Land/Ocean Surface Use
- Power Consumption
- Water Consumption
- Transportation Access
- Access to Resources
- Availability of Algae Feedstock
  - Required Algae Nutrients
  - Algae Strain Hardiness
  - Algae Strain (Refinement) Complexity
- Waste Management

**D. VERIFICATION**

This section is not applicable to this specification.

**E. PACKAGING**

This section is not applicable to this specification.

THIS PAGE INTENTIONALLY LEFT BLANK

## **APPENDIX B. PROJECT MANAGEMENT PLAN**

### **A. INTRODUCTION**

COHORT 311-113A chose the topic of Biofuels for Naval Aviation in Hawaii for its CAPSTONE Project. The project timeline will run from the 2012 summer quarter to the 2013 winter quarter. This CAPSTONE Project will focus on the cultivation and refinement systems necessary to provide 25% percent of the aviation fuel used by the Department of Defense in Hawaii on an annual basis. The two systems (Cultivation and Refinement) are considered a System of Systems known as the Hawaii Naval Aviation Algal Biofuel System (HNAABS). This document details the plans for this CAPSTONE Project to include the problem scope, assumptions, constraints, stakeholders, deliverables and schedule necessary to complete the project.

#### **1. Problem Statement**

USPACOM in Hawaii uses approximately 130 million gallons of aviation fuel a year. This fuel arrives as crude oil from the United States via tankers to refineries located in Hawaii. Delivery of the fuel can be impeded by both weather and terrorist threats. In order to reduce this threat and ensure contiguous operations, USPACOM has expressed an interest in producing 25%, or 32 million gallons, of its required aviation fuel in Hawaii. Cohort 311-113A selected bio-kerosene from algae as the most viable fuel source candidate based on its energy potential (Oilgae, Algae Oil Yields 2013), and the ability to avoid competing with feed crops (Lindenberg 2012). An Enterprise Model was developed by Green Initiatives for Fuel Transition Pacific (GIFTPAC) that identified a critical gap in the Grow, Harvest and Pre-process elements. This Capstone project will focus on Cultivation and Refinement processes necessary to provide sufficient bio-kerosene for blending into aviation grade turbine fuel to meet the required 32 million gallons with a target cost of less than \$3/gal for the bio-kerosene.

## 2. Project Scope

The team decided to restrict the scope of this project to the Cultivation and Refinement system as shown in Figure 117. The Cultivation Team’s responsibility covers the growth and harvesting of algae, the extraction of the oil from the harvested algae and the movement of the green crude from the cultivation facility to the refinement facility. The Refinement Team’s responsibility covers the process of refining the delivered green crude to a bio-kerosene that will be supplied to the HNAABS stakeholders for blending to produce aviation grade turbine fuel.

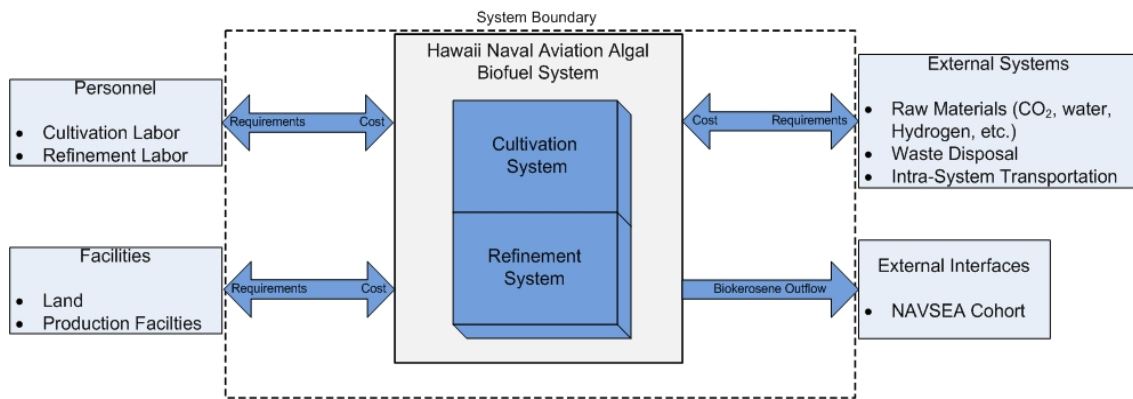

Figure 117. Proposed HNAABS system of systems diagram, showing key interfaces.

The team has decided to treat the HNAABS as a System of Systems (SOS). Using DOTMPLF analysis, the Team has divided the project into several pieces. Cultivation and Refinement will be system designs as material solutions. For personnel, facilities and the external systems identified in Figure 117 the team will derive requirements for each (See Section H.1), recommend an approach for each based on feasibility related to the designed Cultivation and Refinement system, and include associated costs in the Free On-Board cost per gallon of each recommended approach. It is not the intent of this project to design the systems shown outside the system boundary. The NAVSEA cohort will address the external transportation system, blending the bio-kerosene to produce aviation grade turbine fuel, and aircraft performance aspects. The interface with the NAVSEA cohort remains the bio-kerosene output from the refinery.

### 3. Stakeholders

The team has identified the following stakeholders:

- Land owners
  - Bishop Trust
  - Hawaiian State Government
  - Queen Liliuokalani Trust, etc.
- Hawaiian Natural Resources Institute
- Farmers
- Seed/crop developers
- Refiners/Biorefineries
- Ranchers
- Utilities
- Algae developers
- United States Pacific Command (USPACOM) Fuels Team
- NAVAIR Fuels Branch
- USPACOM, Resources and Assessment (J8)
- Environmental Protection Stakeholders (Federal and the State of Hawaii):
  - United States Environmental Protection Agency
  - Department of Energy
  - Department of Defense
  - Hawaii State Department of Business, Economic Development & Tourism
  - Hawaii State Energy Office
  - The Hawaii Department of Agriculture
  - The Hawaii Department of Health
- OPNAV N45 (Energy & Environment in Acquisition)
- County governments (Most of the islands are counties)
- United States Department of Agriculture (USDA)
- University of Hawaii
  - College of Tropical Agriculture
  - Hawaii Natural Energy Institute

- Hawaii Barge companies
- Hawaii Water companies
- Hawaii Chapter of the Sierra Club
- Hawaii Electric Company (HECO)
- Office of Senator Brian Schatz
- NAVSEA NPS Cohort

#### **4. Assumptions**

- Risk and Opportunity Management will be actively performed in accordance with the guidance presented in this PMP to support cost, schedule and requirements baseline control.
- USPACOM will be an active participant throughout this project and is willing to provide necessary support.
- While HNAABS will address the cost to operate the cultivation and refinement system, the primary focus of this CAPSTONE project will be to minimize the Free On-Board cost of the aviation bio-kerosene.
- Target price will be for bio-kerosene only and will not apply to a 50/50 blend.
- This system will address a material solution for the cultivation and refinement system and will provide requirements for external systems, personnel, and facilities as shown in Figure 117
- The CAPSTONE Project solution is based on a 24/7 operation.
- Refinement will be based on aviation fuel specifications in accordance with MIL-DTL-5624U. It is assumed that the process will produce variant aviation fuels similar to the processes used for JP-5

#### **5. Deliverables**

The team is required to provide a Project Management Plan, Integrated Master Schedule (IMS), IPR-1, IPR-2, and a final CAPSTONE project report and presentation at the end of the 2013 winter quarter.

In addition, the team will deliver the following artifacts generated during the conduct of this CAPSTONE Project:

- Performance Specification for the HNAABS
- Analysis of Alternatives (AoA) generated during the project

- Risk Management Plan used during the project
- Functional and Physical Architecture CORE® Models associated with the recommended approach
- Final Capstone Project paper with the recommended solution and methods and rationale used to derive the recommendations

**B. APPLICABLE DOCUMENTS**

- The Risk Management Guide for DoD Acquisition, Sixth Edition
- DoD Directive 5000.01, The Defense Acquisition System

**C. SCHEDULE**

The full Integrated Master Schedule will be provided as an attachment with the final Deliverables to NPS.

**D. PROJECT ORGANIZATION**

Figure 118 shows the IPT structure that will be used for this project. While the organization chart infers a "pipeline" structure, IPT members are encouraged to participate in other IPTs and it is anticipated that members will cross IPTs as necessary to balance the workload throughout project.

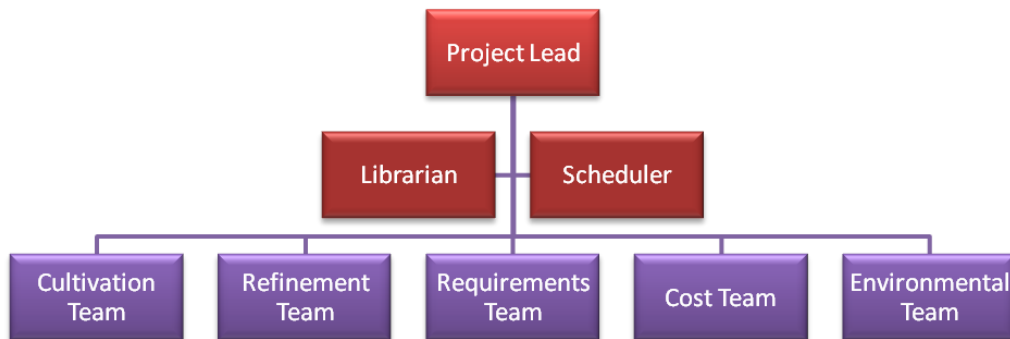

Figure 118. Project organization chart.

**1. Project Team**

Table 81 shows the members of the CAPSTONE project and their respective team as of the generation of this document.

<b>Name</b>	<b>Email</b>	<b>Team</b>
<b>Affandy, Mohamad</b>	mgaffand@nps.edu	Cost
<b>Allen, Charles</b>	cdallen@nps.edu	Cost
<b>Black, Jesse</b>	jablack@nps.edu	Environmental
<b>Bridges, Donald</b>	drbridge@nps.edu	Cultivation
<b>Broadnax, Kevin</b>	kcbroadn@nps.edu	Cost/Librarian
<b>Brown, Scott</b>	Sabrow1@nps.edu	Requirements/CORE®
<b>Campbell, Karolyn</b>	kcampbel@nps.edu	Refinement
<b>Clark, John</b>	jclark@nps.edu	Requirements
<b>Daniels, Quinn</b>	qwdaniel@nps.edu	Project Lead
<b>Dobrowolski, Valerie</b>	vadobrow@nps.edu	Refinement
<b>Janer, Todd</b>	tjaner@nps.edu	Refinement
<b>Janicek, Drew</b>	dmjanice@nps.edu	Refinement
<b>Jeffries, Jessica</b>	jajeffri@nps.edu	Cost
<b>Johnson, Jeffrey</b>	jmjohns2@nps.edu	Cultivation
<b>Kamara, Joseph</b>	jakamara@nps.edu	Environmental
<b>Martin, Julia</b>	martin@nps.edu	Requirements/Scheduler
<b>McGovern, Jonathan</b>	jmmcgove@nps.edu	Cultivation
<b>Morris, Mathew</b>	mnmorris@nps.edu	Refinement
<b>Poling, Edward</b>	epoling@nps.edu	Environmental
<b>Praschak, Megan</b>	mrprash@nps.edu	Refinement
<b>Racelis, Edwin</b>	emraceli@nps.edu	Requirements/Risk
<b>Relova, Mark</b>	mprelova@nps.edu	Requirements/Risk
<b>Rogers, Michael</b>	mjrogers@nps.edu	Requirements
<b>Schmalz, Jordan</b>	jmschmal@nps.edu	Environmental
<b>Soques, Christopher</b>	cjsoques@nps.edu	Cultivation
<b>Thomas, David</b>	drthomas@nps.edu	Cultivation

Table 81. Project team as of 7/30/12. Team members have rotated positions through the course of the project.

## **2. Roles and Responsibilities**

The roles of each of the sub Integrated Project Teams (IPTs) must be clearly defined in a project of such scope in order to minimize instances of redundancy and rework. Communication guidelines have been established by defining distinct interfaces between the IPTs.

**a. Requirements IPT**

The Requirements IPT represent the backbone of the project scope. The focus of the Requirements IPT is to interface with each of the IPTs to ensure that project requirements are continuously being considered during each phase of the project. Their inputs provide the baseline IMS and project model within CORE<sup>®</sup>. In addition, top level requirements derivation is determined by this group and can be seen in detail in Appendix A.

**b. Cultivation IPT**

The role and responsibility of the Refinement IPT in this project is to interact and communicate with the independent IPTs and to take approximately sixty million gallons of green crude per year from cultivation through refinement and have an annual production capacity of thirty-two million gallons of bio-kerosene for a goal price of under \$3 per gallon. The bio-kerosene will be produced for blending into an aviation grade turbine fuel. Since aviation grade turbine fuel is a mixture of a large number of different hydrocarbons, the range of their molecular weights or carbon numbers is restricted by the requirements for the product (e.g., freezing point or flash point). Since different hydrocarbon chain lengths all have progressively higher boiling points, they can all be separated by distillation. In a green crude oil refinery, the oil is heated and the different chains are pulled out by their vaporization temperatures as part of the refinement process. As the refinery will be located in the environmentally conscious state of Hawaii, the refinement process will recycle where possible, minimize waste, and minimize electrical or energy usage during the refinement process.

**c. Refinement IPT**

The role and responsibility of the Refinement IPT in this project is to interact and communicate with the independent IPTs and to take approximately sixty million gallons of green crude per year from cultivation through refinement and have an annual production capacity of thirty-two million gallons of bio-kerosene for a goal price of under \$3 per gallon. The bio-kerosene will be produced for blending into an aviation grade turbine fuel. Since aviation grade turbine fuel is a mixture of a large number of

different hydrocarbons, the range of their molecular weights or carbon numbers is restricted by the requirements for the product (e.g., freezing point or flash point). Since different hydrocarbon chain lengths all have progressively higher boiling points, they can all be separated by distillation. In a green crude oil refinery, the oil is heated and the different chains are pulled out by their vaporization temperatures as part of the refinement process. As the refinery will be located in the environmentally conscious state of Hawaii, the refinement process will recycle where possible, minimize waste, and minimize electrical or energy usage during the refinement process.

*d. Environmental IPT*

Environmental concerns in the context of algae bio-stock production, conversion, and production to fuel will be examined. Methods for assessing effects and anticipated results, or observed effects reported in published literature, will be presented. Environmental issues will be presented in various areas such as Green House gas emissions; air quality; water quality, quantity, and consumptive use; soil; and biodiversity. The Environmental IPT will determine the constraints that the cultivation and refinement systems are required to operate within.

*e. Cost IPT*

Similar to the Requirements IPT, the Cost IPT will interface with each IPT. This will ensure the cost estimators have technical insight into the system and system processes in order to provide the most accurate estimates of the infrastructure development, cultivation, production, and refinement of a viable algae-based bio-kerosene system. The team will compile and analyze the technical data they receive from each IPT and remain knowledgeable of current trends and prices to come up with a projected expenditure for the chosen alternative. In concert with each IPT, the Cost IPT will assess potential material solutions that satisfy the need within the given requirements. The team's primary missions will be twofold: (1) perform focused cost estimates throughout the life of the project to help each IPT narrow their alternatives and examine their trade space by providing economic and business case analyses, and (2) provide a total system lifecycle cost (expressed in dollars per gallon), to include land

purchase/lease, , operations and maintenance, waste disposal, litigation, and production equipment. More detail on the team's cost estimating methodology can be found in Section V.

*f.*      **COR3**

In addition to the above listed IPTs, there is a COR3 group that consists of the Project Lead, Librarian and Scheduler. This team is responsible for high level coordination among the IPTs and direct coordination of the project with the advisors.

(1)      **Project Lead.** The Project Lead is the single point of contact between the cohort and the advisors. Their responsibilities include ensuring communication amongst the IPTs occur by conducting weekly meetings with team leads and coordinate communication of the project status to the advisors.

(2)      **Librarian.** The Librarian's primary tasks mainly exist in the realms of document control and organization. They interface with Professors and the Naval Postgraduate School (NPS) Technology Assistance Center (TAC) in order to produce the current document sharing and control system being utilized by the Project Team. It will be the Librarian's job to be the keeper of all resource documentation for the final deliverable of this CAPSTONE project. A references standard format using the Fifteenth Edition of the Chicago Manual of Style has been selected for this project. In addition, the Librarian is also in charge of distributing action items and situational issues to the Project Team. This action item logging along with the IMS ensure progress is being made throughout the research and writing process.

(3)      **Scheduler.** The Scheduler is responsible for managing the project IMS and updating as necessary based on inputs provided by each IPT and tracking current status. Any items or deliverables that are close to their respective due dates must be reported to the IPTs by the Scheduler.

**E.      MANAGEMENT PROCESS**

The goal of the team organizational structure is to build a strong hierarchy. This will allow a smaller number of people to manage the entire group, thereby enabling more engineers to remain directly focused on the project, rather than efforts in support of the

project. The top level COR3 team addresses the main, when (Scheduler), what (Librarian), and how (Project Leader) questions that will come up during the course of the project. Because the project has many moving parts and likely spans a series of facility architectures and evaluations, the project group was decomposed into five IPTs. Each IPT has a lead that allows the project leadership group to manage five aspects of the project, rather than the efforts of twenty six individual people.

Meetings are held weekly with the IPT leads to determine how each is progressing and to identify missing data elements between groups. IPT leads are empowered to manage their organization as they see fit, allowing for maximum flexibility and preventing micromanagement. This leaves the COR3 team free to manage the interfaces between IPTs without overburdening them with internal group decisions.

The end result of this process will produce four, relatively independent papers, which will be combined into a full CAPSTONE team thesis. Although this will induce integration burden on the entire project, this integration method closely follows the large program systems engineering methods for design integration and qualification. This increase in modularity allows all the teams to work in a more parallel structure, increasing the possible scope of this project while decreasing project cycle time. The Requirements IPT will be the lead for integrating the final CAPSTONE project report.

## **1. Work Breakdown Structure**

Figure 119 shows the work breakdown structure that will be used for this project. The WBS shows the proposed analyses that will be performed as a part of this project.

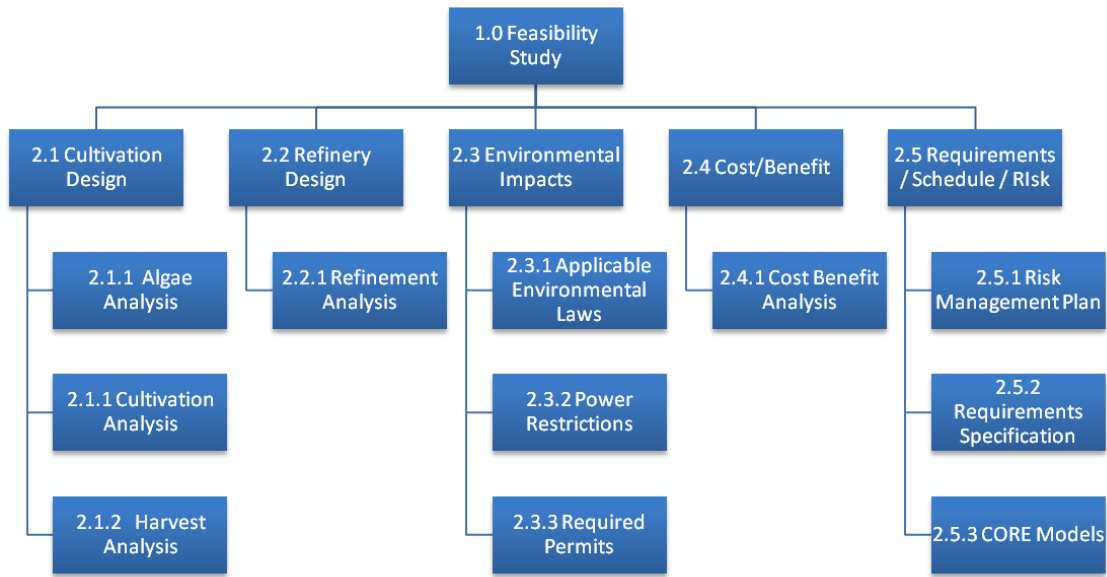

Figure 119. Project work breakdown structure.

## 2. Risk Management Process

The team will implement a risk management process that is based on the principles outlined in the Risk Management Guide for DoD Acquisition, Sixth Edition, August 2006.

The Risk Management Team (RMT) will be composed of members of the Requirements Team, with support from the Project Lead and the IPT Leads. The Project Lead will serve as the owner for risks at the project level, while the IPT Leads will be responsible for risks at the IPT level. The RMT is responsible for the Risk Management Plan, its effective implementation throughout the project, risk trends and metric analysis, and documenting risk management activities and results.

The progression of the risk management process is depicted in Figure 120 and Figure 121.



Figure 120. Risk management planning.

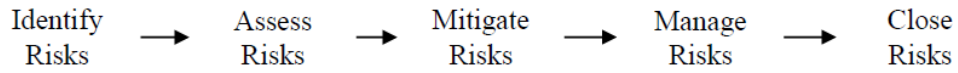

Figure 121. Risk management execution.

When a new risk is identified, its details will be entered in a Risk Assessment Form. This form is then submitted to the RMT Lead for initial assessment. Each risk will be assigned to a Risk Owner, based on the severity of the risk (Project or IPT Level). It is anticipated that the majority of risk mitigation will occur at the IPT level and tracked by the RMT.

Each risk will be rated on its probability of occurrence and its impact to the project. The likelihood and consequence ratings that will be used by the RMT to assess risks are outlined in Table 82 and Table 83.

Likelihood	Level	Likelihood	Probability of Occurrence
	1	Not Likely	~10%
	2	Low Likelihood	~30%
	3	Likely	~50%
	4	Highly Likely	~70%
	5	Near Certainty	~90%

Table 82. Likelihood rating levels (From NAVAIRINST 5000.21B 2008).

Level	Technical Performance	Schedule	Cost
1	Minimal or No Consequence to Technical Performance	Minimal or No Impact	Minimal or No Impact
2	Minor reduction in technical performance or supportability, can be tolerated with little or no impact on project	Able to meet key dates <b>Slip &lt; 1 Week</b>	Budget increase or unit production cost increases <b>&lt; ** (1% of Budget)</b>
3	Moderate reduction in technical performance or supportability with limited impact on project objectives	Minor schedule slip. Able to meet key milestones with no schedule float <b>Slip &lt; 2 Week(s)</b> <b>Sub-system slip &gt; 1 week(s) plus available float</b>	Budget increase or unit production cost increase <b>&lt; ** (5% of Budget)</b>
4	Significant degradation in technical performance or major shortfall in supportability; may jeopardize program success	Project critical path affected <b>Slip &lt; 4 Week(s)</b>	Budget increase or unit production cost increase <b>&lt; ** (10% of Budget)</b>
5	Severe degradation in technical performance; Cannot meet KPP or key technical/supportability threshold; will jeopardize project success	Cannot meet key project milestones <b>Slip &gt; 6 Week(s)</b>	Exceeds APB threshold <b>&gt; ** (10% of Budget)</b>

Table 83. Risk consequence levels (From NAVAIRINST 5000.21B 2008).

The overall risk level will be determined using the probability of occurrence and perceived impact, which will then be shown in a risk assessment matrix as shown in Figure 122. The color codes in the matrix correspond to the overall severity rating for that risk, and mitigation priorities will be assigned based on this rating. The red boxes, which identify “High” severity, will be given top priority for management and oversight. The yellow boxes identify risks of “Moderate” severity, while green boxes mark those risks that are determined to be of “Low” severity. The different severity levels, along with their impact to the project, are illustrated in Figure 123.

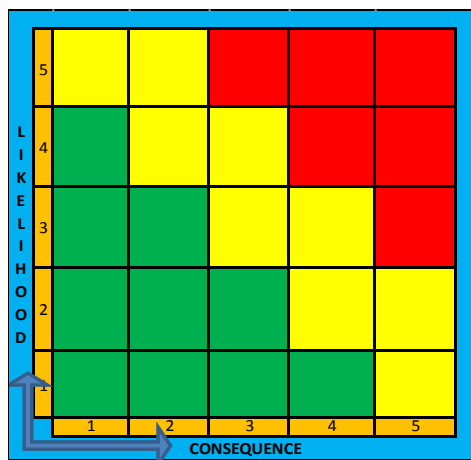

Figure 122. Risk assessment matrix (From NAVAIRINST 5000.21B 2008).

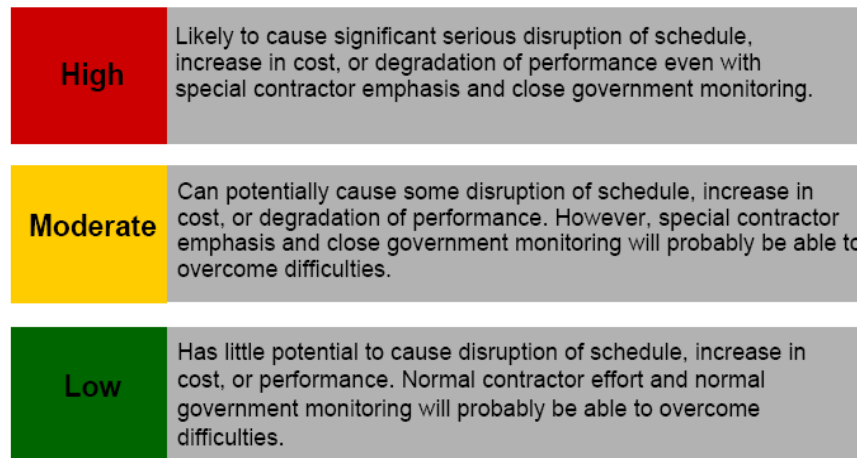

Figure 123. Risk severity levels (From Source Selection Procedures 2011).

The details of the mitigation plan and the target date for mitigation completion will be discussed between the Risk Owner and the RMT and documented in the Risk Assessment Form. The RMT will track the implementation of the mitigation plan and will document the outcome, as well as ensure that the mitigation is performed within the target dates.

Risks that have been identified and assessed will be tracked by the RMT using a Risk Management Spreadsheet. The RMT will hold weekly risk management meetings to discuss new, updated and resolved risks and will publish risk status bulletins for distribution to the members of the Project Team. In addition, the RMT will communicate newly identified risks to the assigned Risk Owners, document completion of mitigation steps, work with project IPTs and subject matter experts to facilitate solutions to risks, and analyze risk trends and metrics to determine additional aspects of the project that warrant increased management oversight.

### **3. Communications**

The HNAABS feasibility study effort encompasses the inputs of 25+ individuals spread across IPTs specializing in areas of great interest to the project. The cornerstone of communications within the subgroups is of course E-Mail. Through Sakai, each cohort member can upload their preferred E-Mail address to receive communications. Thus, when messages are sent through Sakai, carbon copies can be automatically forwarded to personal addresses. In addition, the messaging host via Sakai offers the ability to index the addresses of each individual and their assigned sub IPT. Class wide or group emails are easily accomplished. Sakai helps keep each project member involved in discussions.

Between class sessions, IPT meetings, and a Sunday evening “tag-up” sessions featuring project leadership and IPT POCs, action items and documentation are created. SAKAI provides the cataloging that the cohort needs to stay organized and on task. Its Discussion Forum feature allows tailored folders for both internal working groups and major deliverables. In addition, major milestone documents that will be produced by the cohort can be organized and indexed within the Resources tab.

As this feasibility study begins to evolve, team communications needs may require adaptation. The HNAABS Project Team is confident that SAKAI can continue to meet the communication and document control needs, and the team will continue to interface with the instructors and NPS to expand on current capability should the need arise.

## **F. TECHNICAL APPROACH**

This section describes the systems engineering work being done to decompose the problem statement. It will address a top level description of the problem and potential solutions to the goal of providing 32 million gallons of bio-kerosene per year. Furthermore, the integration of this system concept into the physical and legal environment of the Hawaiian Islands will be addressed. Because the scope of this project does not pass the Request for Proposal (RFP) timeframe, actual systems integration will not be described, as that will depend highly on the specific facilities solution provided during the sourcing of construction and development contracts. Finally, the design will be assessed for feasibility from cost and development perspectives. This final section will summarize the high level metrics used to evaluate system feasibility, and will also include the outline of the planned cost and verification modeling to be performed as a part of this Capstone project.

### **1. System Model**

The Requirements IPT is responsible for modeling the HNAABS system. CORE<sup>®</sup> was utilized to display the development of the system architecture as well as the corresponding system requirements. Each IPT fed their respective inputs into the model during this development.

### **2. Cultivation System**

As mentioned previously, the Cultivation Team will be responsible for complete algal production to include the growth and harvesting of algae and the extraction of base oil products from the algae bio-stock. The amount of oil produced from a given amount of biomatter is dependent on a variety of factors. For example, certain algae strains are

more resistant to climate effects including temperature changes and amount of precipitation. This generally comes at a price as the energy invested into the production of proteins and carbohydrates for robustness results in less energy invested toward the production of oil (Conklin 2007). On the other hand, algae strains with lower oil contents can grow much faster than those with high oil contents. One challenge the team must address is choosing an algae strain that balances oil content and growth rate and can be paired with an efficient cultivation process that is compatible with that particular strain.

Figure 124 depicts the overall process of producing green crude oil to deliver to the refinery. In this case, the upper-right oval titled “High-Energy-Density Biofuels” is a precursor liquid that is able to be refined to JP-5. Also, since it is the first step in the end-to-end process, it is critical that the size scale of the cultivation process is determined accurately.

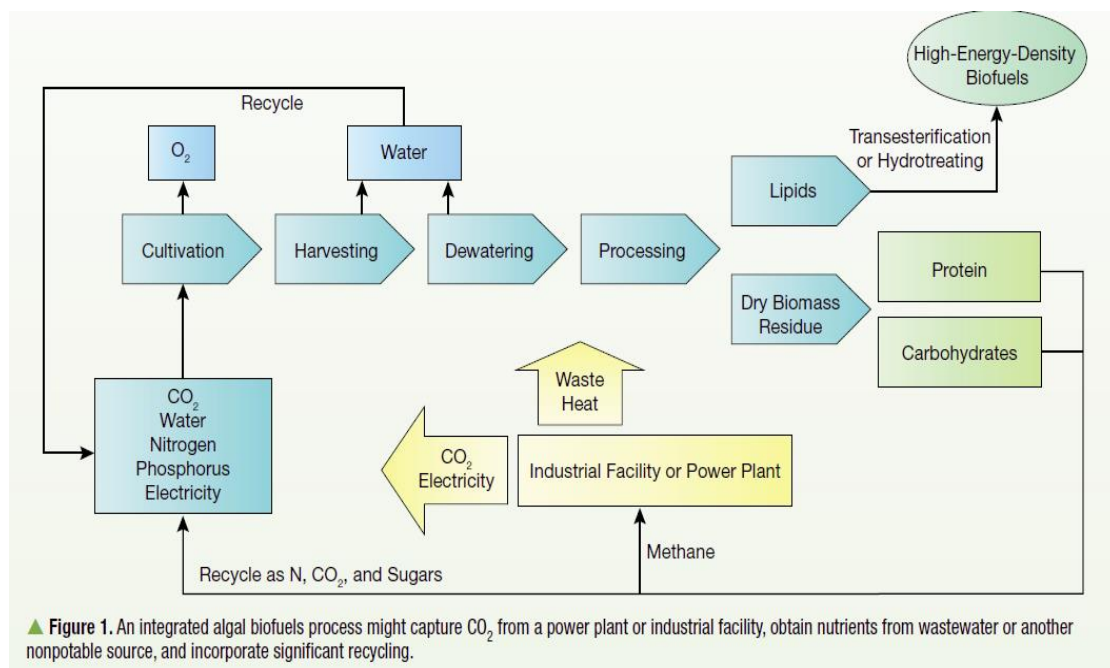

Figure 124. Algal biofuels production process (From Darzins and Knoshaug 2011).

*a. Cultivation System Description*

The Cultivation IPT is responsible for a feasibility analysis of the green crude production process to include an analysis of alternatives to determine a site and

choose a cultivation method. In order to reduce the scope of this effort to a level that is manageable in the timeframe available, the Cultivation Team will employ assistance from the other IPTs to develop four AoA groups which will focus on methods for growth, harvesting, drying and oil extraction. The primary area of concern will be the investigation of the growth methods: pond cultivation, photobioreactors (PBR), offshore membrane enclosures for growing algae (OMEGA) and a possible combination of methods. The subsequent methods will be studied in an effort to optimize the entire cultivation process in extracting the highest percent of green crude from the selected algae strain while utilizing the least amount of land and energy. Likewise, while it is entirely possible to extract green crude from algae bio-stock that has been cultivated in the continental United States and ship the oil to Hawaii, the team will initially focus on analysis assuming the containment of the full cultivation process within the Hawaiian Islands. These decisions may drive certain aspects of the feasibility analysis including the amount of land and water available to support the cultivation process and the types of algae strains that can be successfully utilized based on the cultivation process, climate, and geography.

Of the three primary cultivation growth methods being considered, there are specific strengths and weaknesses that make a particular method favorable with respect to efficient production in the Hawaiian Islands. The team will research existing cultivation facilities and available resources in the area to determine an adequate location and process to meet fuel production goals. Notwithstanding, there remains the possibility that any one process may not be able to sustain the total rate of production required which is why the fourth alternative of combining more than one method may need to be prescribed.

Open pond cultivation refers to growing algae in natural lakes and ponds or artificial ponds or containers. In this method, a constant flow of nutrients and carbon dioxide are supplied to the pond while paddlewheels are used to circulate algae, water, and nutrients in a manner such that the algae are forced to the surface at regular intervals to maximize exposure to sunlight. While open ponds are simple, inexpensive, and easier to construct relative to other cultivation methods, there are many limitations to open pond

cultivation as well. Open ponds are susceptible to the environment and contamination from animals and other undesirable strains of algae (Darzins and Knoshaug 2011). Furthermore, uneven light intensity, evaporation, and unregulated temperatures can result in less than optimum algae growth. Closed ponds operate in the same manner while reducing some of the limitations associated with open pond systems. Closed ponds eliminate many of the contamination concerns of open ponds and can actually increase the rate of algae growth by artificially controlling the amount of carbon dioxide provided.

A photobioreactor, on the other hand, is a closed system in which all the necessary inputs for algae growth are regulated. As a result, PBRs provide a more controlled process through the regulation of carbon dioxide, water, nutrients, temperature, and light exposure. Like closed ponds, PBRs offer many of the same advantages with respect to protection against contamination from bacteria and undesirable algae strains (Darzins and Knoshaug 2011). While better control of cultivation parameters allows for higher biomass concentration and tailored oil concentration, PBR production costs are much higher than both open and closed pond systems.

Finally, the OMEGA cultivation method refers to the process of growing macroalgae as opposed to microalgae in an offshore location using a coastal wastewater supply. OMEGA leverages both the pond cultivation method and PBR system while minimizing the impact to local land and water usage requirements. Not only do the algae use carbon dioxide and nutrients from the wastewater to produce biomass, but the algae clean the wastewater as well (J. Trent 2012). While this process enhances biomass output, it is in early development and introduces extensive infrastructure and harvesting requirements.

Since cultivation of algae is a resource intensive process, the feasibility analysis will also include an investigation of land acreage or ocean surface requirements, available water and carbon dioxide supply, and power and labor requirements associated with the harvesting of biomass. Limited resources within the Hawaiian Islands will require efficient use of resources and recycling of by-products. As such, frequent communication with the cost and environmental teams is critical to understand financial impacts of infrastructure decisions and local laws and regulations.

***b. Technical Performance Measures***

Although appropriate values have not yet been determined for the technical performance measures associated with the cultivation process, a preliminary list of expected performance measures is provided below:

- Land/ocean surface requirements in acres
- Yield in bio-stock per acre
- Yield in oil from bio-stock (60 million gallons per year)
- Percent water content in bio-stock
- Amount of biomass waste
- Amount of waste water
- Amount of CO<sub>2</sub> consumed
- Amount of chemical nutrients consumed
- Input energy consumed
- Man-hours consumed

***c. Data Items***

A list of data items to be tracked is shown below:

- List of potential algae strains and growth properties
- List of existing infrastructure
- Amount of rainfall per year
- Land topography
- Climate data
- Transportation cost data
  - Truckload size and cost data
  - Pipe infrastructure costs
- Facility construction data
  - Land costs
  - Material and building costs
- Power requirements for different cultivation processes

*d. Cultivation Functional Analysis*

While functional analysis of the cultivation process has not yet been completed, this is expected to be accomplished prior to IPR-1. A functional decomposition of the general cultivation process will be performed in CORE<sup>®</sup> followed by a process specific decomposition for each of the three growth processes under investigation: pond, PBR, and OMEGA cultivation. This functional analysis will ultimately aid the Cultivation Team in the development of a cultivation architecture document.

Figure 125 shows a generalized list of inputs, outputs, and constraints the Cultivation Team must account for during the functional analysis process. Natural resources such as land, sunlight, carbon dioxide, and water will be utilized to grow algae and produce green crude. This process will create by-products in the form of biomass waste and waste water that can be disposed of or recycled in accordance with environmental regulations with some financial impact. Consequently, this diagram is also helpful in understanding the relationship between the various project IPTs.

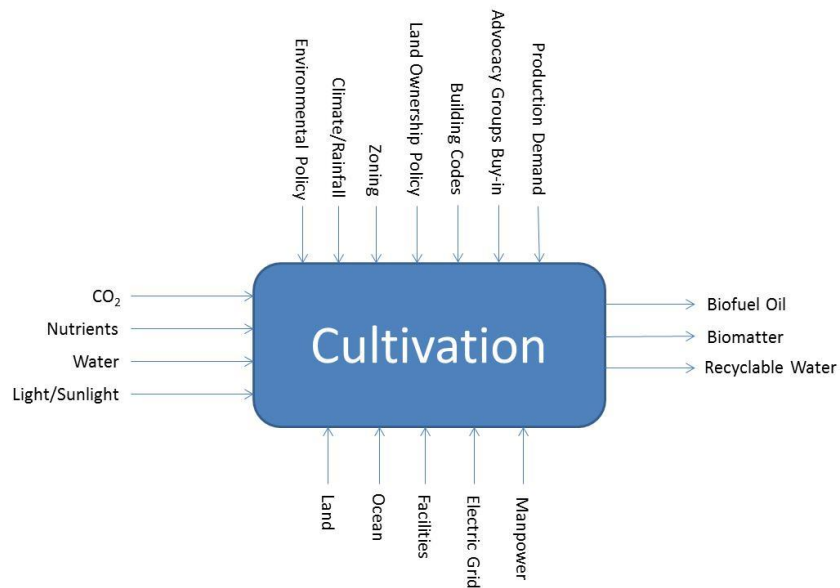

Figure 125. Cultivation ICOM.

### **3. Refinement System**

The primary purpose of the refinement system is to take the green crude produced in the cultivation system and refine it into a useable bio-kerosene that can be blended to produce aviation grade turbine fuel.

#### ***a. Refinement System Description***

The refinement of green crude oil follows a similar process to that of petroleum based crude oils. A green crude refinement system requires many of the same key elements that are utilized in a petroleum oil refinery. Thus, the system architecture and physical infrastructure of a green crude refinery leverages heavily off of the existing architectures of petroleum based oil refineries.

The green crude refinement system that will satisfy the needs of the stakeholder will consist of three key elements, or functions: Distillation, Hydrocracking and Hydrotreating. The first step of the refinement process is Distillation or separation of the oil. Oils of varying molecular composition and density will be produced by the Cultivation System and these different products will separate naturally in a distillation column. Denser oils such as green diesel will filter to the bottom, while lighter oils, similar to gas and kerosene, will rise to the top. The next key function in the refinement process is Hydrocracking, where heavy hydrocarbon oils are subjected to high pressure and temperature in the presence of hydrogen and a catalyst to break the hydrocarbon bonds and create lighter hydrocarbons with shorter chains. The final key function, Hydrotreating, is used to remove sulfur through a catalytic chemical process in order to reduce the sulfur dioxide (SO<sub>2</sub>) emissions during fuel combustion.

Although the actual green crude refining process and infrastructure are the focal point of the refinement system, there are other essential system elements. One of these essential elements includes the resources to effectively and efficiently operate and maintain the refinery. Resources include the power required to run the refinery and the manpower to operate and maintain the refinery. Some of the other essential system elements include the infrastructure necessary to dispose of waste products and recycle the reusable byproducts of the green crude refining process. Through successful

incorporation of all of the aforementioned system elements, the refinement system will be capable of meeting Technical Performance.

This refinement system will operate in a very similar manner to a petroleum based oil refinery. The HNAABS refinery will be dedicated to the refining of green crudes, particularly those that are algae-based. The refinement system will be functionally independent from all other major systems (i.e., Cultivation) in the HNAABS.

***b. Technical Performance Measures***

Technical Performance Measures (TPM) will be used as a tool to provide program-level visibility on the progress of satisfying technical requirements. These performance measurements will support assessments of the extent to which operational requirements will be met and provide early detection of risk or problems requiring program management's attention. TPMs will also be used to support assessments of the impact of proposed changes at lower level functions. TPMs for the refinery will be established by the Refinement IPT systems engineer lead and based on the Measures of Effectiveness and Measures of Suitability for the system. The Refinement IPT, in conjunction with the Requirements and Risk IPTs will develop a baseline selection and criteria for continuous verification of actual verses anticipated performance to confirm program progress.

The TPM Selection Process involves

- Using the systems engineering process, identify all subsystems and functions that are critical to satisfaction of the programs KPPs.
- Establishing TPM baseline parameters and determine appropriate verification methods.
- Conducting regularly scheduled evaluations of each TPM to determine current status and variances requiring additional action.

TPMs shall be evaluated and updated monthly by the Refinement IPT and submitted to the Program Manager. The evaluation should include the current threshold and objective value along with the actual measurement of the technical parameter and its trend data. If a TPM trend indicates a potential failure to meet required performance

metrics, a technical performance risk report shall be generated and tracked by the Requirements and Risk IPTs. This report shall include the above parameters for the TPM along with a variance analysis and a recommended course of action to meet the performance metric.

*c. Data Items*

Data items will need to be obtained by the Refinement IPT in order to design and develop a refinery system that meets user needs and TPMs. Data items will be continuously researched and evaluated throughout the requirements and design phases. Some of these data items include:

- Biofuel refining processes for algae-based green crude
- Data on all existing refineries in Hawaii
- The refinery size needed to produce 32 million gallons of bio-kerosene
- All elements needed to build a new Biofuel refinery
- The bio-kerosene composition needed to blend with aviation grade turbine fuel
- The waste byproducts produced by the refinery

*d. Functional Analysis*

A detailed functional analysis will be conducted by the Refinement IPT in order to mitigate risk, ensure efficient system design, expedite integration, communicate information to stakeholders, and alleviate costs to accomplish a successful program. This process will be performed with contributions from appropriate IPTs, such as Cost and Environmental, to provide cohesive team work and address stakeholder priorities.

To begin with, a high level functional analysis will be outlined and scoped based upon the required inputs and outputs of the system along with the mechanisms and controls that will drive the system. This is outlined in the Refinement ICOM Diagram, shown in Figure 126.

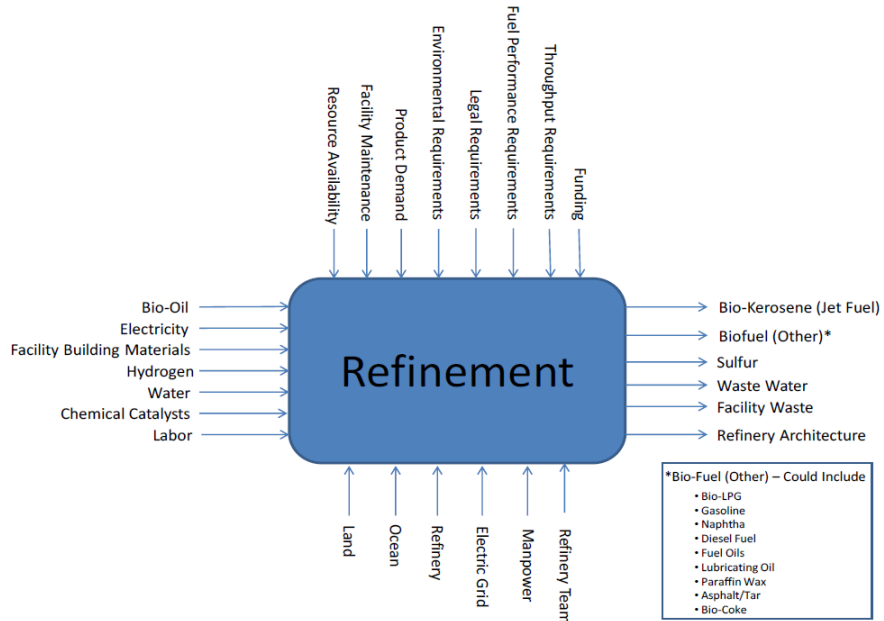

Figure 126. Refinement ICOM.

The Refinement ICOM Diagram will be translated into a detailed functional analysis once the final scope and boundaries of the project have been defined by all teams contributing to the program. The detailed schematic and complete functional analysis will be available in the final Capstone Project Report. A high level view of the refinement functions is demonstrated in Figure 127.

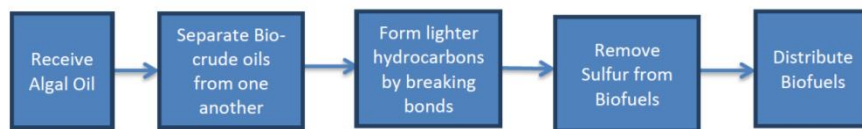

Figure 127. Refinement functional diagram.

#### 4. Environmental

The specific impacts associated with the Algae feed stock is dependent upon the source, the method of production, the technology used to convert the algae to fuel and distances traveled to transport the bio-kerosene, the use of best management practices, and site selection. Team coordination will be paramount to ensure

environmental compliance with chosen technology. Figure 128 shows the ICOM diagram for the Environmental IPT.

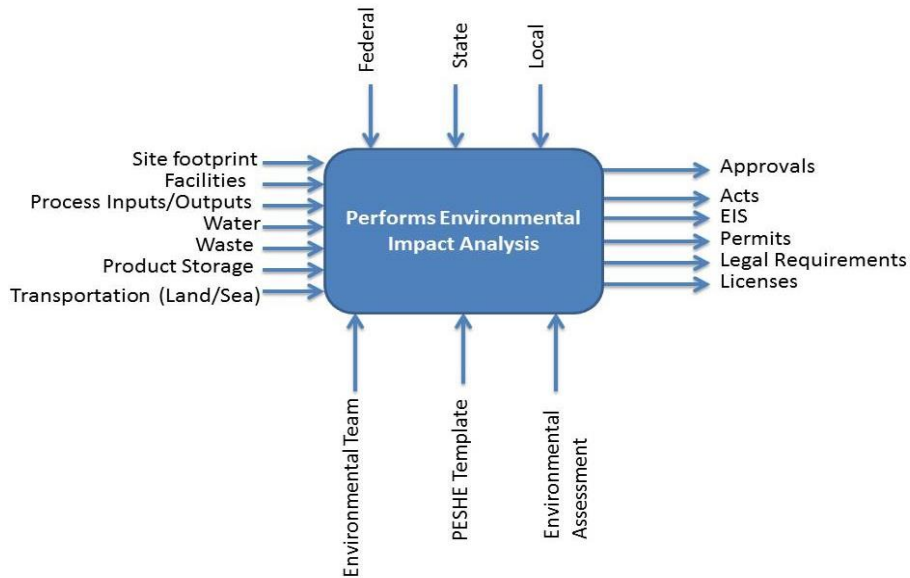

Figure 128. Environmental ICOM.

*a. Environmental Concerns*

Environmental concerns in the context of Algae bio-stock production, conversion, and production to fuel will be examined. Methods for assessing effects and anticipated results, or observed effects reported in published literature, will be presented. Environmental concerns will be presented in various areas such as Green House gas emissions; air quality; water quality, quantity, and consumptive use; soil; and biodiversity.

DoD Directive 5000.01, The Defense Acquisition System, requires acquisition programs be conducted in compliance with Federal, State, and local laws and regulations, treaties, and agreements. It is the team’s responsibility for ensuring that Environmental, Safety, and Occupational Health Compliance can be achieved through the system design of the HNAABS. The National Environmental Policy Act mandates specific procedures must be followed by federal agencies to determine potential environmental impacts that may result. The Capstone team will use the Programmatic

Environmental, Safety, and Occupational Health Evaluation (PESHE) for the HNAABS project to assess and evaluate environmental impacts on the community.

***b. Legal Concerns***

There are many federal environmental requirements that apply to biofuel production facilities and bio-stock cultivation. The State of Hawaii and its local environmental agencies take the lead in implementing the federal environmental program, and also have state requirements, in addition to the Federal environmental program.

The United States Protection Agency's goal is to work with biofuel facility operators to ensure that human health and the environment are protected.

The following products will be provided in support of the cultivation and refinery of algae biofuel in the State of Hawaii:

- National Environmental Policy Act
- Clean Water Act
- Dredging and filling permit (if applicable)
- Storm Water Construction Permit (if applicable)
- Safe Drinking Water Act
- Water Use permit
- Clean Air Act
- Construction Permit (if applicable)
- Pollution Prevention Act
- Toxic Substance Control Act

All and any other applicable acts, permits or regulation will be provided.

Figure 129 shows the Environmental IPTs spider diagram for required permits, applicable acts, laws, and regulations.

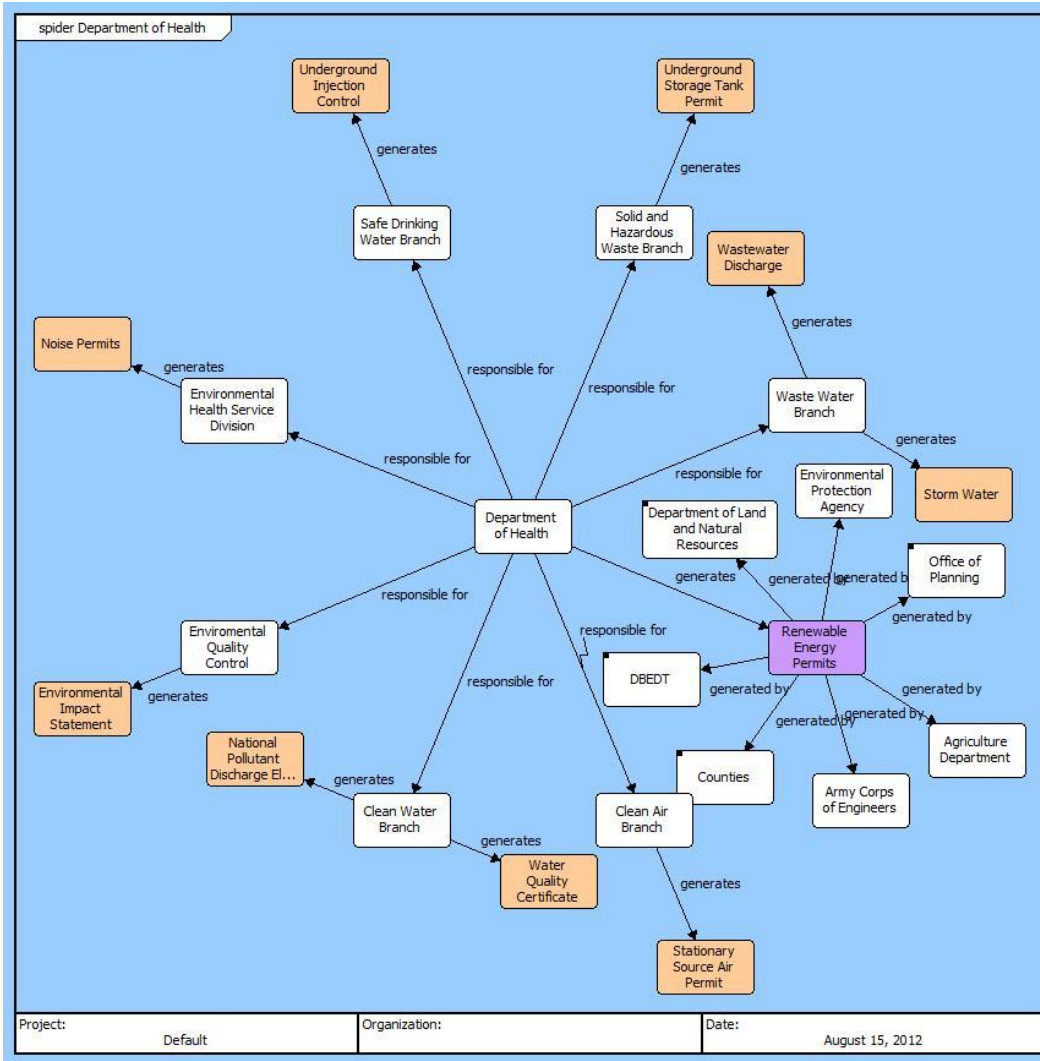

Figure 129. Environmental spider diagram.

## 5. Design Verification

The design verification process of this system will be imperative to determining the feasibility of these solutions. The bulk of the system design will be evident in the cultivation and refinement processes. Interfacing with the end user USPACOM will provide visibility in the design accuracy of the biofuels system design proposed here with respect to system requirements.

**a. Requirements Verification**

The primary elements of requirements verification include; understanding the user's need, identifying alternatives to their need statement, identifying metrics to measure output, and managing the systems configuration to ensure success. USPACOM has identified the need for a serviceable biofuel to reduce the overwhelming reliance on crude oil based fuels. Interfacing with USPACOM on the established requirements will be pivotal in the verification process. The system integrators must be on the same page with the user to ensure that the interpretation of the requirements is the same and to guarantee completeness. The primary metrics that the HNAABS system will be evaluated on during the verification process is quality derived by overarching requirements. These metrics can be traced back to the HNAABS system requirements. The algal biofuel system must have the capability to continuously harvest algae, refine oil, and produce a serviceable biofuel. The system shall also grow algae in a sufficient quantity to provide 32 million gallons of bio-kerosene for blending to produce an aviation grade turbine fuel. This translates into 60 million gallons of green crude, to be produced annually. System configuration and functional design of this system (ranging from cultivation to green crude refinement) go hand-in-hand with these primary requirements.

**b. Cost Analysis**

Any analysis involving Cost estimates must exhibit sound estimating logic, clear documentation of sources, and consistency amongst reporting detail. These vital characteristics can ensure accuracy and defensibility of the estimate and will drive the evaluation process of biofuels affordability.

The Cost IPT, in concert with the other IPTs, will perform market research on the primary cost inputs required to build the master estimate. Resources available to the teams include public information documentation on the World Wide Web, the NPS library, and interviews with various USPACOM personnel. USPACOM will be the first line and primary source of cost data. Any data point (such as the average cost to operate a notional refinery, transport material, labor, etc.) coming from the user will be pivotal in building an accurate estimate. It is understood that USPACOM may not be able to

provide every single data point needed, thus, secondary sources have been identified. These sources include market research and online documentation and can be used to extrapolate data points. The research process will uncover the technical baselines and cost data points needed to build a defensible estimate.

Cost data is merely a piece of the cost estimate portion. Selecting a methodology and controlling the technical inputs governing said data points is imperative. The basic elements, such as manpower, material usage, failure rates, etc. are coupled to the cost data points in the estimating process. An example of how the cost estimates will come to life is quite simple. In order to build a manpower estimate, labor rates are applied to manpower requirements for a refinery facility. Said manpower estimate is aligned with the operational life cycle of the facility to build the estimated manpower cost for that system. Estimating methodologies will be centered on the validity of the data point. Cost data points from USPACOM will drive predominately Parametric and Actuals based cost estimating. Research of like and similar systems, such as refineries and production plants currently in use, will drive utilization of Analogy as the primary methodology. The engineering methodology requires a detailed bottoms-up composition of our subsystems. The availability of this level of the data is unforeseen and is projected to be a rarely used methodology.

The Free On-Board cost of energy is a very large component of interest for DoD. More than simply the cultivation, refinement, and conservation of waste materials behind the creation of our biofuel is needed to truly assess the cost of this material to the fleet. Along with the Requirements and Environmental IPTs, these cost elements will be identified, quantified, and normalized properly so that the user and decision makers know what the makeup of a barrel or gallon of bio-kerosene looks like.

All cost estimating processes will be aligned with the guidance published by the Cost Assessment and Program Evaluation Office (CAPE), a component of the DoD. All methodologies behind any benefit analysis, calculation of Free On-Board costs, and life cycle operating costs will be verified by their guidance set forth. Also, a member of the Cost IPT belongs to the AIR 4.2 Cost Department and production and life cycle sustainment subject matter experts are at their disposal. In summary, the Cost Team will

be diligent in interfacing with USPACOM, the other project IPTs, the AIR 4.2 Cost Department and every other resource available in building an estimate that meets the expectations of the CAPSTONE project. The ICOM for the Cost IPT is shown in Figure 130.

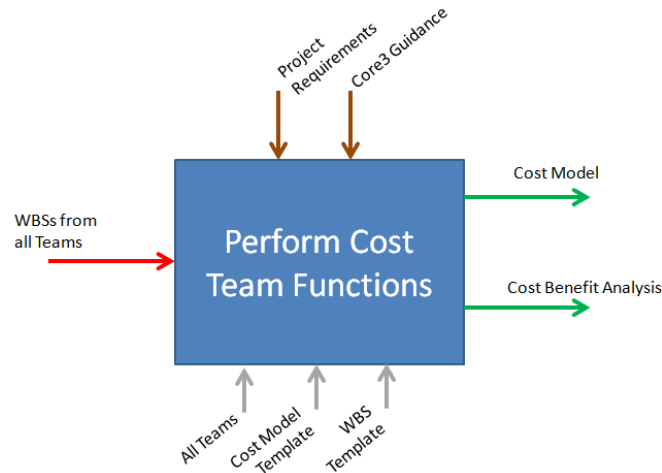

Figure 130. Cost ICOM.

## G. MODELS, TOOLS, TECHNIQUES

Two CORE<sup>®</sup> models are being generated during this project. The first CORE<sup>®</sup> model will be used to model the project itself and will be used as a program management tool. This model will allow the COR3 Team to identify and manage interfaces between the project IPTs through the use of an N2 diagram as shown in Figure 131.

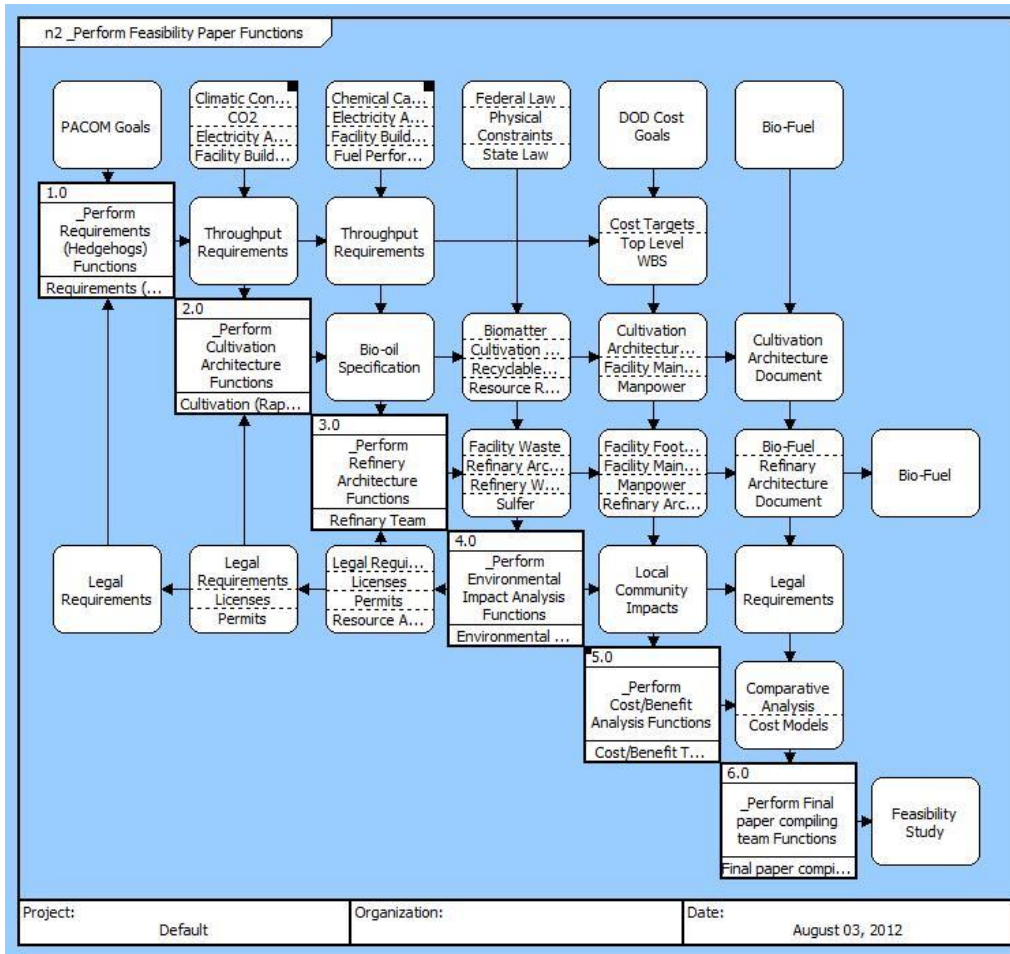

Figure 131. Capstone project N2 diagram.

The second CORE<sup>®</sup> model will be used to model the HNAABS system. It will track the requirements, functional architecture, physical architecture, risk, concerns and constraints through development of the project. It will be delivered with the final Capstone Project Paper.

A significant quantity of data is flowing out of the Cultivation and Refinement IPTs to drive portions of the Environmental and Cost/Benefit analysis. These paths will require the most management effort to ensure that the data is developed promptly per the IMS and delivered in sufficient detail to feed the later efforts of this project.

There are also significant feedback functions from the Environmental IPT that will drive design and decomposition decisions in the Cultivation and Refinement IPTs.

By identifying these feedback loops early, the HNAABS Project Team was able to work on the deliverable schedule and ensure sufficient communication exists between the IPTs to produce a quality product.

## **H. PROJECT DATA**

### **1. HNAABS SYSTEM LEVEL REQUIREMENTS**

1. The HNAABS system of systems shall consist of a cultivation system and refinement system. (KPP)
2. The refinement system shall produce a minimum of 32 million gallons of bio-kerosene which will be supplied to the stakeholders for blending to produce aviation grade turbine fuel. (KPP)
  - a. The cultivation system shall produce a minimum of 60 million gallons of green crude oil annually. (MOP)
3. The HNAABS system of systems shall have a greater than or equal to 90% (Ao) Operational Availability. (KPP)
  - a.  $Ao = MTBM / (MTBM + MDT)$ . Mean Time Between Maintenance (MTBM) & Maintenance Downtime (MDT). *See Figure 132*
  - b. Cultivation and Refinement, working in series, shall have individual Ao greater than or equal to 95% to meet the overall 90% requirement.
    - i. Each system shall have less than or equal to 436 hours of scheduled maintenance downtime a year during a 24/7 operation schedule.
    - ii. 436 hours equates to 2 1/2 weeks of maintenance downtime and 8,300 hours or 49 1/2 weeks a year for production.
    - iii. Required throughput should be 1.21 million gallons/week of green crude from cultivation and 650,000 gallons/week of bio-kerosene from refinement.
    - iv. A 20% design margin will be included to allow for unscheduled maintenance, future growth and operational surges which will require a minimum throughput of 1.5 million gallons of green crude from cultivation and 800,000 gallons of bio-kerosene from refinement.

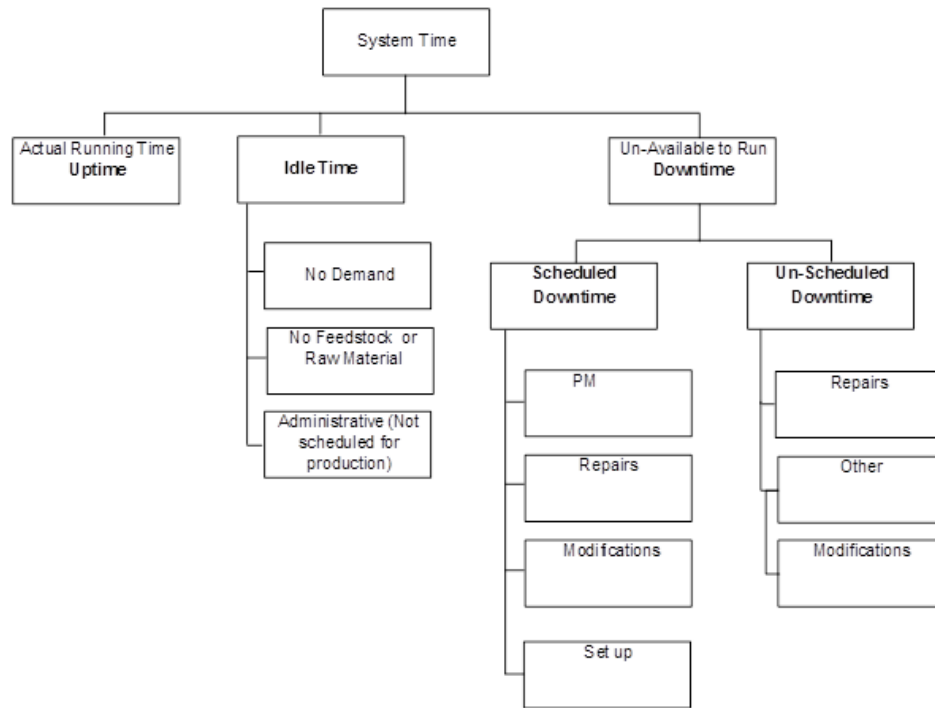
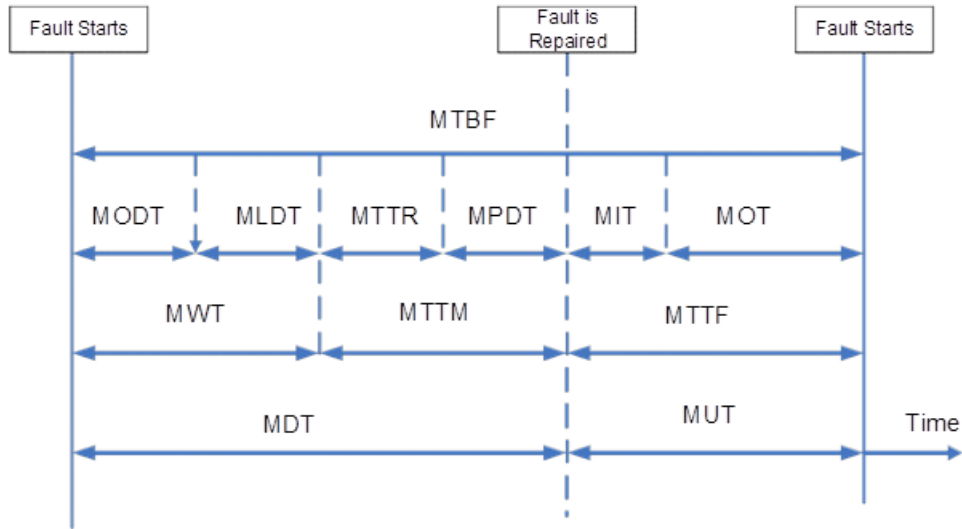

Figure 132. Cultivation/refinement system time.

4. The HNAABS system of systems shall have a greater than or equal to 90% Reliability. (KSA)
  - a.  $R = (R_A)(R_B)$ ,  $R_s = e^{-(\lambda_1 + \lambda_2 + \dots + \lambda_n)t}$ .  $R_A$  = Cultivation Reliability,  $R_B$  = Refinement Reliability,  $\lambda$  = Failure/Hour = 1/MTBF,  $t = 8,300$  hours of expected operation. *See Figure 133*
  - b. Cultivation and Refinement, working in series, shall have individual Reliabilities greater than or equal to 95% to meet the overall 90% requirement.



MTBF	Mean Time Between Failures
MODT	Mean Operative Downtime
MLDT	Mean Logistic Downtime
MTTR	Mean Time to Repair
MPDT	Mean Preventative Maintenance Downtime
MIT	Mean Idle Time
MOT	Mean Operational Time
MWT	Mean Waiting Time
MTTM	Mean Time to Maintain
MTTF	Mean Time to Failure
MDT	Mean Downtime
MUT	Mean Uptime

Figure 133. Reliability terms (MTBF).

5. The HNAABS system of systems shall meet the Free On-Board production cost of \$3/gal by 2020. (KSA)
6. The HNAABS system of systems production should meet all local, state, and federal environmental regulations. (MOE)

## 2. HNAABS Work Breakdown Structure

Biofuel Work Breakdown Structure (WBS)		
WBS Lvl	WBS #	WBS Element
1	1	<b>WBS for Design-Bid-Build Project</b>
2	1.1	Phase 1: Prospectus
3	1.1.1	Project Management Plans for Phase 1
4	1.1.1.1	Scope management Plan
4	1.1.1.2	Cost and Schedule Management Plans
4	1.1.1.3	Quality Management Plan
4	1.1.1.4	Human Resources Management Plan
4	1.1.1.5	Communication Management Plan
4	1.1.1.6	Risk Management Plan
4	1.1.1.7	Procurement Management Plan
3	1.1.2	Description of Customer Needs
3	1.1.3	Preliminary Plans of Alternatives
3	1.1.4	Estimates for Alternatives
3	1.1.5	Cost/Benefit Analysis
3	1.1.6	Report
2	1.2	Phase 2: Selected Alternative
3	1.2.1	Project Management Plans for Phase 2
3	1.2.2	Environmental Studies
4	1.2.2.1	Biological
4	1.2.2.2	Archaeological
4	1.2.2.3	Air Quality
4	1.2.2.4	Water Quality
4	1.2.2.5	Social and Economic
3	1.2.3	Estimates for Alternatives
3	1.2.4	Draft Report
3	1.2.5	Final Report
2	1.3	Phase 3: Real Property
3	1.3.1	Project Management Plans for Phase 3
3	1.3.2	Appraisal
3	1.3.3	Acquisiton
3	1.3.4	Relocation of Occupants
3	1.3.5	Demolition
3	1.3.6	Relocation of Utilities
3	1.3.7	Hazmat Removal
3	1.3.8	Environmental Mitigations

Biofuel Work Breakdown Structure (WBS)		
WBS Lvl	WBS #	WBS Element
2	1.4	Phase 4: Contract Award Documents
3	1.4.1	Project Management Plans for Phase 4
3	1.4.2	Detailed Plans for Selected Alternative
4	1.4.2.1	Civil Plans
4	1.4.2.2	Water Supply Plans
4	1.4.2.3	Structural Plans
4	1.4.2.4	Furnishing Plans
3	1.4.3	Estimate
3	1.4.4	Bid Documents
3	1.4.5	Signed Contract
2	1.5	Phase 5: Construction
3	1.5.1	Project Management Plans for Phase 5
3	1.5.2	Civil Work
4	1.5.2.1	Earthwork
4	1.5.2.2	Pavement
3	1.5.3	Water Supply, Drainage and Sanitation
4	1.5.3.1	Drainage
4	1.5.3.2	Water Supply
4	1.5.3.3	Sanitary Sewers and Purification
3	1.5.4	Structural Work
4	1.5.4.1	Structures
4	1.5.4.2	Electrical Mechanical
3	1.5.5	Furnishings
2	1.6	Phase 6: Operations and Sustainment
3	1.6.1	Project Management Plans for Phase 6
3	1.6.2	Program Management
3	1.6.3	Budget and Marketing
3	1.6.4	Engineering, Research and Development
3	1.6.5	Legal
3	1.6.7	Security
3	1.6.8	Lifecycle Support
4	1.6.4.1	Training & Education
4	1.6.4.2	Infrastructure Maintenance & Upgrades (structural, electrical, mechanical etc)
4	1.6.4.3	Tools Maintenance & Upgrades (HW/SW etc)

## APPENDIX C. RISK MANAGEMENT PLAN

### A. INTRODUCTION

#### 1. Purpose

The Hawaii Naval Aviation Algal Biofuel System (HNAABS) project Risk Management Plan (RMP) provides the framework that the HNAABS Project Team will follow to manage risks and opportunities throughout the project. Those risks and objectives are related to events that could occur throughout the project and may impact its scope, schedule, cost, performance and other objectives.

In this document, **risk** is defined as “an uncertain future event which may cause an execution failure in the program. It is the possibility of loss, injury, disadvantage, or anything that has a negative impact on a program. It is a measure of the inability to achieve program objectives” (Defense Acquisition University 2011). Each risk has three important components: a future root cause, the likelihood (probability) of occurrence of the root cause, and the consequence (impact) if it occurs (Defense Acquisition University 2011). Furthermore, **critical risks** are those which may directly impact the scope, schedule, cost, and performance of the HNAABS project deliverables.

Risk management is the process that the HNAABS Project Team will use to plan, assess, handle and monitor all of the risks associated with the project. This document outlines the different activities, responsibilities and timelines that the Project Team will undertake to effectively manage project-wide and team-level risks. This RMP, and the risk management process outlined in it, will allow the HNAABS Project Team to create effective strategies to address possible barriers to the success of the project.

Several portions of this document were adapted from the “Risk Management Plan (Template and Guide)”, published by the Department of Defense’s Business Transformation Agency as part of its Enterprise Integration Tool Kit.

## 2. Objectives

The success of the HNAABS project depends on making informed and timely decisions regarding risks. The specific objectives of this RMP are to

- Ensure that critical risks are identified early, communicated to project members, mitigated effectively, and escalated up the project authority chain in a timely fashion.
- Promote careful and diligent attention to risks impacting the HNAABS project.
- Track and document information that will allow the HNAABS Project Team to focus efforts on risks that have high likelihood and high impact with effective coordination.
- Ensure that the appropriate stakeholders are informed and, if necessary, induce their participation in mitigating risks.
- Record discussions and mitigation of program risks, for audit purposes.

The goal of this RMP is to identify and address risks in a proactive manner throughout the HNAABS project's lifecycle. The HNAABS Project Team will manage risks to decrease their likelihood of occurrence and decrease the impact to program cost, schedule, performance, defects and stakeholder dissatisfaction. Figure 134 shows a hierarchy of the various activities that are part of the HNAABS risk management process.



Figure 134. Overview of HNAABS risk management process.

## 3. Scope and Context

The RMP consists of the following components:

- The process to be followed for identifying and managing risks,
- The timing of events and activities within the risk management process,

- The mitigation steps required to address each risk,
- The responsible members of the HNAABS Project Team that will monitor and manage the risks,
- The tracking and documentation of risks using various tools.

Risk management will begin with initial planning of the management process and early assessments of potential risks. Those risks that are identified in the early stages of the project will be addressed as soon as possible. Risks and HNAABS project areas where these risks can potentially occur will be monitored and managed according to the process identified in this document. These actions will be performed throughout the entire project lifecycle. The scope of the RMP will cover all risks identified at every stage of the project.

Risk management will be carried out at all levels of the HNAABS Project Team hierarchy. Proper execution of the HNAABS risk management process will ensure that mitigations are implemented at the appropriate level, but actions taken will be communicated to the entire HNAABS Project Team. While the RMP offers guidance on managing risks at all levels of the project, the primary focus of risk management for HNAABS is on critical risks (as defined in Section V.A.1); similar processes will be used within sub teams to handle less-critical risks.

While risks must be identified and effective mitigations tailored for each project, there are standard risk factors, standard assessment criteria to identify and evaluate risks, and standard mitigation approaches that have been defined for systems engineering projects in general. These risk factors, assessment criteria, and mitigation approaches are referred to as the Risk Reference Model (RRM). For the purposes of this project, the NAVAIR RRM will be used.

This RMP will ensure that both individual risks and common risks (i.e., risks that apply to more than one area of the project) are both identified and mitigated. Managing the effective completion of mitigation actions will be integrated with overall project tasks and assignments.

Risk management will be performed in conjunction with issue management. The key difference between issue management and risk management is the element of

uncertainty inherent in risks. Uncertain events that could impact the project will be identified and managed through this RMP. Note that risks could lead to identification of issues and issues could drive identification or resolution of risks.

In addition to addressing identified risks through this risk management process, it is expected that the project planning process will also include quantitative risk assessment processes to validate project schedule and budget estimates.

#### **4. GUIDING PRINCIPLES**

To ensure successful implementation of the process outlined in this RMP, the HNAABS Project Team will adopt the following “ground rules”:

- Decisions will not be revisited once made (unless new facts become available).
- Escalation of risks follows the process defined in this document.
- A single owner is assigned responsibility for a risk even if several people work to mitigate it.
- Work and communicate progress on most severe risks first.
- Set realistic due dates and then work to meet the dates.
- Mitigate risks at the appropriate level (i.e., project, team, sub-team).
- Responsible team leads determine and agree on the risk severity level.
- Document the planned risk mitigation history and actual mitigation of a risk. The documentation will serve as a key input to root cause analysis, key learning, metrics, and risk analysis.
- For high impact, unanticipated risks, a 24-hour decision turnaround may be required or as determined by the Project Lead. In such cases, the Risk Management Team members will make the decision. (Defense Acquisition University 2009)

#### **B. RISK MANAGEMENT ORGANIZATION**

Figure 135 depicts the HNAABS Project organization involved in risk management. Roles and responsibilities are delineated in the subsequent sections

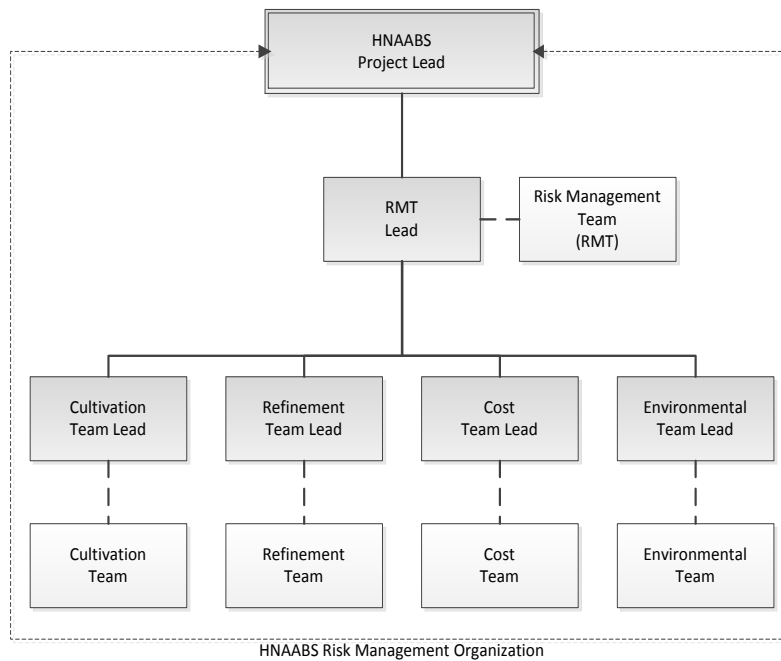

Figure 135. HNAABS risk management organization.

## 1. Risk Management Organization

The entire Risk Management Organization (RMO) is responsible for the RMP, its effective implementation throughout the HNAABS project, trends and metric analysis, and documenting risk management activities and results. It is also responsible for identifying the RRM to use as a basis for assessing project risks or identifying candidate mitigation approaches.

## 2. Risk Management Team (RMT)

The RMT has overall facilitative responsibility for the risk management process. As such, the RMT will ensure that the RMP is fully executed. Specific responsibilities include the following activities:

- Develop the RMP
- Identify and select RRM
- Maintain the RMP in line with configuration management procedures.
- Plan and coordinate Risk Management meetings.

- Present risk status during Risk Management meetings
- Generate risk reports, including trends and metric analysis, for risk meetings and ad-hoc requests.
- Clarify, consolidate and document risks.
- Maintain and monitor risk data in a Risk Management database
- Establish initial priority, owner, and target due date.
- Monitor the status of risk mitigation.
- Communicate status to risk originators and risk owners.
- Escalate communication if expected mitigation action deadlines are not met.
- Execute the risk closure process.
- Work with the various Project Teams to facilitate risk identification and mitigation.
- Approve the mitigation of high/medium severity level risks.
- Support mitigation implementation.
- Assist in cross-organization and controversial risk mitigation to include determining the involvement of other organizational resources.

### **3. Risk Originator**

The Risk Originator is any person in the project who identifies a risk. Specific responsibilities include the following:

- Identify any significant risk to the project.
- Submit risk information to the RMT (via a “Risk Summary” form)
- Verify that the risk is eventually mitigated.

### **4. Risk Owner**

The Risk Owner is the person to whom the RMT assigns primary responsibility for mitigating the risk. The team leads for each of the Project Teams will fulfill this role for team-level (or lower) risks, while the RMT Lead will be responsible for risks that involve more than one area/team of the project. The Project Lead will be responsible for overall project risks. The Risk Owner has the following responsibilities:

- Assess the risk and create a risk mitigation plan that meets RMT approval.
- Mitigate risk per the risk mitigation plan.

- Recommend risk closure to RMT.

## **5. Project Management Team (PMT)**

The Project Management Team (PMT) has the authority to approve the risk mitigation proposed by the Risk Owner. This authority varies by the severity of the risk (as described in Appendix C). Additionally, the PMT members are notified of risk mitigation. It is anticipated that the majority of risk mitigation will take place at the Project Team level. Specific responsibilities include the following.

- Accountable for ensuring timely mitigation of risks and escalating risks to the RMT for support as needed.
- Lead the implementation of proposed mitigations.
- Review status, severity, ownership, and completeness of risks.
- Determine risks to be returned to the appropriate Project Teams.
- Establish severity of risks and define target dates.
- Establish ownership of risk and confirm target dates.
- Identify risks that require escalation in the risk mitigation approval chain.
- Work with Project Teams, subject matter experts, and the RMT Lead to facilitate solutions to risks.

## **C. RISK MANAGEMENT INFORMATION**

To effectively manage risks, standard information must be captured about each identified risk. This information is defined by the RRM that is chosen for the HNAABS project. This section outlines the key attributes captured in the Risk Management Tool (hereafter known as RM Tool), which is described in detail in Section V.F of this document. In addition, this section describes the elements of an effective RRM.

### **1. Detailed Risk Attributes**

The data elements listed in Table 84 along with their defined list of values will be captured as key risk information in the RM Tool.

FIELD NAME	DEFINITION	POSSIBLE VALUES	
Risk ID	Uniquely identifies each risk.	001, 002, etc. (The RMT assigns this number)	
Title	Brief descriptor of risk	Free form text field	
Causal Factor	List of possible future causes for each risk.	Free form text field	
Description	Full description of risk	Free form text field	
Consequence	List of possible consequences if risks are realized.	Free form text field	
Risk Owner	Name of person assigned to mitigate the risk.	Project resource name	
Risk Impact Date	If impact date is known, enter Date	Date	
Risk Type	Primary area of the Project to which the risk pertains.	<u>Area</u>	<u>Definition</u>
		Project Performance	▪ Risk presents a detriment to the project processes or to meeting the project objectives.
		Scope	▪ Risk presents scope impacts.
		Schedule	▪ Risk presents a schedule impact.
		Cost	▪ Risk presents a cost impact
		Cultivation	▪ Risk presents a cultivation impact
		Refinement	▪ Risk presents a refinement impact
		Environment	▪ Risk presents an environmental impact
Mitigation Plan	Mitigation plan detailing actions, schedule, assigned resources, etc.	Table of mitigation actions, schedules and assignees (may be provided as a separate document).	

Table 84. Risk data elements that need to be captured for each risk that is identified (After Risk Management Plan Template and Guide 2009, p. 11-15).

When a new risk is identified, information about it is initially recorded by the Risk Originator and documented on the Risk Summary Form, shown in Figure 136.

## Hawaii Naval Aviation Algal Biofuel System (HNAABS) Risk Summary

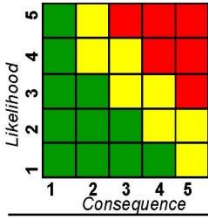

Likelihood

Consequence

Title: \_\_\_\_\_ Risk#: \_\_\_\_\_

Causal Factor: \_\_\_\_\_

Description: \_\_\_\_\_

Consequence: \_\_\_\_\_

Risk Type: \_\_\_\_\_

Risk Impact Date: \_\_\_\_\_

Risk Owner: \_\_\_\_\_

Mitigation Plan	Assignee	Planned		Actual		Assess (L,C) i.e. (2,4)
		Start	Finish	Start	Finish	
1.						
2.						
3.						
4.						
5.						
6.						
7.						Resolved

Figure 136. Risk summary form used for documenting risk information.

## 2. Risk Reference Model

The HNAABS Project will utilize the NAVAIR Risk Analysis methodology, which involves assessing project risks based on the probability of their occurrence and the consequences to the project if the risks are realized. Each risk will therefore be assigned a score that reflects the assessed level in these two factors. Table 85 shows the different levels that will be assigned to each risk, depending on its consequence to the project’s cost, schedule or technical performance.

Consequence	Level	Technical Performance	Schedule	Cost
	1	Minimal or no consequence to technical performance	Minimal or no impact	Minimal or no impact
	2	Minor technical shortfall, no impact to high level requirements	Additional activities required, schedule slip workable to meet key dates. Slip < 1 weeks	Budget increase. Cost increase > 1%
	3	Moderate technical shortfall but workaround available which will eliminate impact to high level technical requirements	Minor schedule slip, no impact to key milestones. Slip < 2 weeks	Budget increase. Cost increase > 5%
	4	Unacceptable, workarounds available which will eliminate impact to high level technical requirements	Program critical path affected, all schedule float associated with key milestones exhausted Slip < 6 weeks	Budget increase. Cost increase < 10%
	5	Unacceptable, no alternative exist	Cannot meet key program milestones. Slip > 6 weeks	Budget increase. Cost increase > 10%

Table 85. Assessment of risk consequence to project (From NAVAIRINST 5000.21B 2008, Enclosure 1).

Table 137 shows the different levels that will be assigned to each risk, based on its likelihood of occurrence during project execution.

Likelihood	Level	Likelihood	Probability of Occurrence
	1	Not Likely	~10%
	2	Low Likelihood	~30%
	3	Likely	~50%
	4	Highly Likely	~70%
	5	Near Certainty	~90%

Figure 137. Assessment of risk likelihood of occurrence (From NAVAIRINST 5000.21B 2008, Enclosure 1).

## D. RISK MANAGEMENT PROCESS

Risk management involves three major phases: risk management planning, risk management execution, and risk management closeout.

### 1. Risk Management Planning

The HNAABS Risk Management Planning will involve the following activities:

*a. Development of the Risk Management Plan (RMP)*

The development of the RMP has been undertaken since project inception by members of the Requirements/Schedule/Risk Management Team. The initial draft of the RMP is scheduled for release on August 28, 2012 to the HNAABS Project members and academic advisors for review and approval. Once approved, the RMP will be updated and revised as the project progresses, to ensure that risk management activities are in line with overall project objectives and goals. The RMT will have the responsibility of updating/revising the RMP.

The final version of the RMP will be included as part of the final deliverables for the HNAABS Project.

*b. Identification of Candidate Risk Reference Models (RRM)*

Identification of candidate RRM's has been performed by the RMT since project inception. This involved solicitations from RMT members of RRM's that they are familiar with, or have otherwise used in previous projects. Since an overwhelming majority of the RMT members are from NAVAIR, all of the solicitations identified the NAVAIR Risk Reference Model as a candidate RRM.

*c. Selection of HNAABS Risk Reference Model (RRM)*

The NAVAIR RRM was selected for use in the HNAABS RMP by members of the RMT, based on their familiarity with its processes and usage.

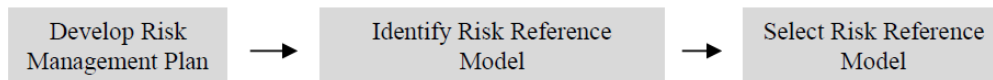

Figure 138. Risk management planning (From Defense Acquisition University 2011).

**2. Risk Management Execution**

The Risk Management Execution phase shall be used throughout the project to manage risks from identification through closeout. This phase will be initiated

immediately after the Risk Management Planning phase. Initial risk identification is undertaken by each Project Team.

Figure 139 depicts the risk management process steps. Subsequent sections detail each process step, the escalation procedure, the Risk Management meeting schedule, and an overview of the feedback and reporting process.

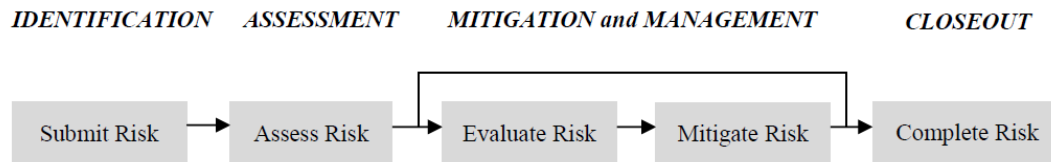

Figure 139. Risk management execution (From Defense Acquisition University 2011).

**a. Submit Risk**

The Risk Originator identifies a potential risk by completing a “Risk Summary” form, available for download as a PDF file in the Project Resources section of the NPS SI0810 Class Sakai site. The Originator will then submit the completed form data to the RMT Point of Contact (POC). Every risk is automatically considered a "New" risk after submission to the RMT. The risk remains in its "New" status until the RMT has performed an assessment of the risk.

**b. Assess Risk**

The RMT POC will initiate the assessment of new risks during the weekly RMT meetings. The assessment will consist of reviewing the data provided by the Risk Originator and completion of the Risk Assessment Matrix for each risk.

Figure 140 shows the Risk Assessment Matrix, which is designed to show the level for a particular risk after analysis by the RMT. The RMT will first establish estimates of the likelihood of occurrence and severity of impact for each risk based on information provided by the Risk Originator. These will be plotted in the matrix to determine the overall risk level.

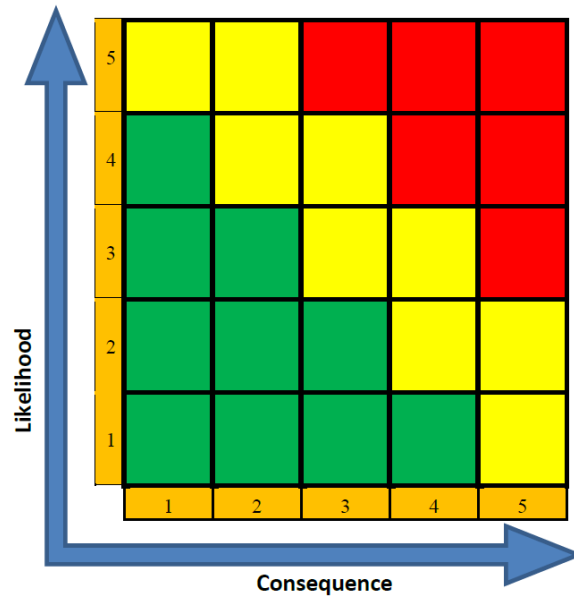

Figure 140. Risk assessment matrix (From NAVAIRINST 5000.21B 2008, Enclosure 1).

Each “square” in the matrix is color-coded to facilitate easier categorization of risk levels. These levels are listed in Figure 141 along with a description of each risk level.

<b>High</b>	Likely to cause significant serious disruption of schedule, increase in cost, or degradation of performance even with special contractor emphasis and close government monitoring.
<b>Moderate</b>	Can potentially cause some disruption of schedule, increase in cost, or degradation of performance. However, special contractor emphasis and close government monitoring will probably be able to overcome difficulties.
<b>Low</b>	Has little potential to cause disruption of schedule, increase in cost, or performance. Normal contractor effort and normal government monitoring will probably be able to overcome difficulties.

Figure 141. Risk levels (From Source Selection Procedures 2011).

The information submitted by the Risk Originator will be validated for consistency and accuracy, either through requests for clarification from the Originator or by RMT determination of values for missing data fields. Data such as Risk Type, Causal

Factor and Consequence may not be immediately known and may require further discussions with the Originator. Nevertheless, the RMT will populate any missing data fields with preliminary values during assessment, based on the context of the original information submitted by the Originator.

The newly identified risks will be added to the Risk Watch List maintained by the RMT. This list will be the primary means of tracking project risks, and will be presented to attendees in the weekly RMT meeting.

*c. Evaluate Risk*

After the assessment, the RMT will determine the Risk Owner who will be responsible for planning the mitigation of the risk and overseeing the mitigation process. Using information provided by the Risk Originator and the Risk Assessment Matrix, the RMT will make the determination based on the following factors:

(1) **Risk Type.** Each risk has an associated type, which is either specified by the Risk Originator or is determined by the RMT during the assessment phase. The risk type will identify whether the risk pertains to an individual team or to several teams. It will also identify whether the risk impacts project-level goals (i.e., cost, schedule, performance) or team goals (i.e., cultivation, refinement etc.).

(2) **Risk Consequence.** The consequences of each risk are crucial to understanding its impact to project. Often, these consequences reveal the severity of its impact, which would otherwise be unknown or downplayed if consequences are not reviewed properly. The RMT will ensure that consequences identified by the Originator fit the risk type and level. The RMT will reallocate the ownership to a different authority level if the consequences are more appropriately addressed by that authority.

(3) **Risk Level.** Risk ownership will depend on the level in which the risk affects the project. Figure 142 shows the mapping of each risk level to a risk owner. In general, higher risk levels warrant assignment to personnel that have higher authorities in the project. For critical or very high risk levels, the Project Lead shall assume risk ownership. In the lowest levels, where risks usually affect individual

team processes and activities, the individual Team Leads will be the risk owners since they usually have enough authority to implement mitigations for such risks. The RMT Lead will be assigned ownership for moderate risks that transcend more than one team, or those that affect activities within the project (but do not have major/severe impacts to the overall project goals and objectives).

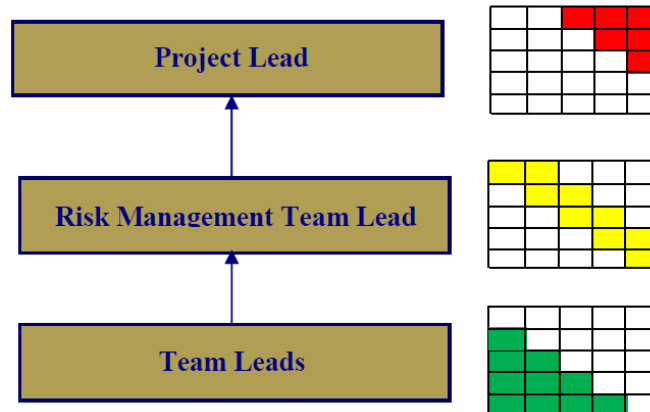

Figure 142. Risk ownership based on risk level (After Risk Management Plan Template and Guide 2009, 24).

*d. Mitigate Risk*

Once risk ownership has been established, the identified Risk Owner will be tasked to formulate a mitigation plan which will be submitted to the RMT for approval and tracking.

(1) **Risk Response Strategies/Techniques.** The first step the Risk Owner takes in risk mitigation is to adopt a risk response strategy or technique. Table 86 contains a listing of the strategies/techniques that will be employed on the project along with a description to help in defining the term.

TECHNIQUE	DESCRIPTION
ACCEPTANCE	This technique recognizes the risk and its uncontrollability. Acceptance is a “passive” technique that focuses on allowing whatever outcome to occur without trying to prevent that outcome. This technique is normally used for “low” or “very low” risks where a scope efficient means of reducing the risk is not apparent.
AVOIDANCE	This technique uses an approach that avoids the possibility of risk occurrence. Avoidance can be thought of as nullifying the risk by changing the contract parameters established between the Customer and Integrator. The following items represent ways of avoiding risks: <ol style="list-style-type: none"> <li>1. Work Scope Reduction</li> <li>2. Changing the requirements and/or specifications</li> <li>3. Changing the Statement of Work (SOW)</li> <li>4. Changing the Technical Baseline</li> <li>5. Developing and submitting Waivers and Deviations</li> </ol>
CONTROL	This technique is made up of actions that are to be taken that reduce the risk likelihood or impact. Control-based actions occur at all points throughout the program's lifecycle and are typically the most common response. They typically identify an action or product that becomes part of the work plans, and which are monitored and reported as part of the regular performance analysis and progress reporting of the project.
INVESTIGATION	This technique defers all actions until more work is done and/or facts are known. Investigation-based responses do not define any mitigation for reducing an individual risk. They are responses to risks where no clear solution is identified, and further research is required. Investigation may include root cause analysis. Investigative responses immediately and directly lead to a greater aggregated Program risk. This is because the probability quantifier for each risk includes the effect of the applied response, for which there is none, and the level of control quantifier indicates the level of influence to apply that response, which is low.
REDUCTION	Reduction is the active lowering of risk by a planned series of activities. Techniques include: <ul style="list-style-type: none"> <li>• Rapid Prototyping</li> <li>• Early multi-discipline involvement</li> <li>• Consultant and/or specialist reviews</li> <li>• Simulation</li> <li>• Modeling</li> <li>• Trade Studies</li> <li>• Team Workshops</li> <li>• Advance design models</li> <li>• Reduce Dependencies</li> <li>• Customer involvement</li> <li>• Joint Applications development groups</li> </ul>
TRANSFERENCE	Transference is the process of moving something from one place to another or from one party to another. In this, the risk can be transferred to the customer or to the contractor. Typically, transference includes the sub-contracting to specialist suppliers who are able to reduce the overall risk exposure. This technique is best utilized during the proposal process. Transfer can also include the use of third party guaranties, such as insurance backed performance bonds.

Table 86. Risk response strategies/techniques (From Risk Management Plan Template and Guide 2009, 22-23).

(2) **Developing and Documenting a Risk Mitigation Plan.**

The second step the Risk Owner takes in risk mitigation is to document their risk response strategy/technique in a step-by-step, sequential plan. The sequential plan contains those steps that when completed, will lead to the risk being successfully mitigated. When the Risk Owner completes this plan, it becomes the Risk Mitigation Plan.

Each item in the Risk Mitigation Plan shall have the following information clearly defined:

- Mitigation Step. The action to be performed to mitigate the risk or a part of it
- Assignee. The project resource that will perform the action
- Planned Start and Finish dates. Estimates of key dates for implementation
- Actual Start and Finish Dates. Populated as the mitigation is implemented
- Risk Assessment. An estimate of the Risk Level (occurrence and impact) after the Mitigation Step has been completed.

(3) **Obtaining Approval of the Risk Mitigation Plan.** A

completed Risk Mitigation Plan will be submitted by the Risk Owner to the RMT no later than the Planned Start date listed in the first Mitigation Step of the plan. Preferably, the submission should occur immediately after the Plan has been completed, to facilitate a review/approval period for the RMT.

The need for approval (and notification) of a mitigation plan from the RMT before it is implemented depends on the risk management level that applies to the risk that is being mitigated. For risks assigned to the Project Lead, an approval is almost always required due to the nature of the risk and its consequences (exceptions can be granted when there is an immediate turn-around required, on a case-by-case basis). Other levels require some approval from the RMT, while those that pertain to team-level risks may not need approval at all. Table 87 provides a general guideline when seeking approval and providing notification to the RMT of a mitigation plan.

RISK/ISSUE MANAGEMENT LEVEL	RISK MITIGATION APPROVAL REQUIRED	RISK/ISSUE NOTIFICATION REQUIRED
Project Lead	Very High	High
RMT Lead	High/Medium	Low
Team Leads	Low/Very Low	N/A

Table 87. Risk management approval and notification guide.

(4) **Performing the Risk Mitigation.** Upon approval of the Mitigation Plan, the Risk Owner will begin the implementation of the Mitigation Steps that are necessary to bring the risk to an acceptable level. The risk level that is considered acceptable is the one that is listed for the last Mitigation Step in an approved Mitigation Plan. Essentially, this means that the acceptable risk level can only be achieved if all the Steps are implemented successfully. Therefore, the RMT will monitor the completion of each Step so that the desired risk level is reached in the time frames listed in the Plan.

The Risk Owners for risks that are in the High and Moderate levels will be required to provide status updates to the RMT at least one day before the scheduled RMT meeting. These updates will be required until all the Steps have been completed and the RMT has assigned a “Completed” status to the risk. Each status update must include the following:

- Completion progress of each Mitigation Step (as a percentage)
- Actual Start Date of Mitigation Step
- Actual Finish Date of Mitigation Step
- Revised Planned Start/Finish Date, if delays are anticipated
- Comments regarding mitigation implementation

Status updates for risks in the Low level are not required, but they are highly recommended for record-keeping purposes.

(5) **Complete Risk.** When the final Mitigation Step in an approved Mitigation Plan has been executed successfully, the RMT will assess whether the desired risk level has been reached. If so, the RMT Lead will assign a “Completed” status to the risk, which will be recorded in the Risk Management Database. At this point, the RMT will cease tracking the risk and remove it from the Risk Watch List.

### 3. Risk Management Closeout

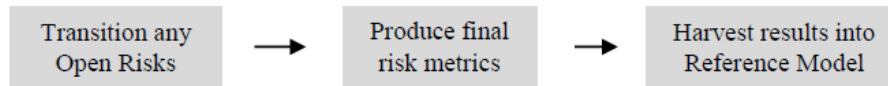

Figure 143. Risk management closeout (From Defense Acquisition University 2011).

Risk Management Closeout is the final phase in the execution of the Risk Management Process. This phase will ensure that all identified risks are mitigated and brought to their desired risk levels at the completion of the process. During Closeout, the following actions will be undertaken by the RMT:

- Finalize any changes to the RMP
- Determine if there are any Mitigation Steps that are still pending.
- Determine if there are any risks that are still being tracked in the Risk Watch List
- Determine if there are any risks that do not have “Completed” status in the Risk Management Database.
- Generate a list of all risks and their final risk level
- Submit the generated list to the Requirements Team Lead for inclusion into the Final Capstone Report
- Complete a Risk Management Report, detailing actions performed during the Risk Management Execution, for inclusion into the Final Capstone Report

The Risk Management Closeout is scheduled for February 22, 2013 in conjunction with the completion of all Project Team activities.

### 4. Risk Escalation Procedures

In cases where an escalation of a risk to a higher authority or to a higher risk level is necessary, the RMT is the sole authority that will make such decisions. The Risk Owner must request escalations by stating the reason for escalation in the weekly Status updates. To maintain consistency throughout the project, escalated risks will be managed using the same process used for new risks.

The RMT will escalate risks through the following process:

- Determine if request for escalation is valid, based on reasons stated by Risk Owner
- Determine the new risk level (occurrence and consequence)
- Assign the escalated risk to the new Risk Owner (based on new risk level)
- Update the risk ownership and status in the Risk Management Database

## **5. Risk Management Team Meeting**

The RMT meeting will be conducted on a weekly basis on Wednesdays unless a schedule change is necessary. The schedule change will be communicated to the entire PMT during the weekly PMT meeting, to ensure that everyone involved in risk management (stakeholders, risk owners and originators, RMT members, PMT members) can attend if required. The RMT meeting will be scheduled for one (1) hour, unless risk discussions require a longer time frame. The decision to extend the RMT meeting duration will be made by the RMT Lead either before or during the meeting and will be communicated via email to the attendees.

The RMT meeting will be facilitated by the Risk Management Team Lead. Meeting attendees who are unable to attend in person may join the Requirements/Schedule/Risk Elluminate session that is provided by the Naval Postgraduate School for the SI0810 Class.

RMT meeting attendees may include:

- RMT Team Lead
- RMT members
- Project Lead – for project-level risk discussions
- Team Leads – for team-level risk discussions
- Stakeholders – if discussions require their participation
- Risk Originators – if clarification of identified risk is necessary
- Any HNAABS Project personnel who wish to participate in risk discussions

## **6. Feedback and Reporting Processes**

The RMT will provide standard risk notices and reports, outlined in Table 88, on a weekly basis in conjunction with the RMT Meeting. These notices and reports are

intended to facilitate the widest dissemination of information regarding project risks to HNAABS project personnel and stakeholders.

REPORT	SENDER	AUDIENCE	TIMING
Risk Watch List	RMT Lead	RMT Meeting Attendees	One day prior to the Risk Management meeting.
Risk Meeting Report	RMT Lead	Risk Originators Risk Owners RMT Meeting Attendees	Within 24 hours of the Risk Management meeting.

Table 88. Standard risk notices and reports.

In addition, a variety of views and reports can be made available to all HNAABS Project personnel at any time by contacting the RMT Lead.

**a. Risk Watch List**

The Risk Watch List is the primary means of tracking risks that are being mitigated throughout the project lifecycle. The List will include the following information:

- Risk ID and Title
- Risk Short Description
- Risk Owner
- Current Risk Level
- ID/Description of Current Mitigation Step
- Expected Completion Date for Mitigation Step
- ID/Description of Next Mitigation Step
- Expected Start Date of Next Mitigation Step
- Risk Status

**b. Risk Meeting Report**

The Risk Meeting Report is the primary means of communicating the results of RMT Meeting Discussions to attendees, as well as any project personnel or stakeholder. The Report will include the following information:

- Bulleted list of topics discussed during the meeting

- List of issues identified
- Copy of Risk Watch List
- Status updates for each risk in the Risk Watch List

## E. OPPORTUNITY MANAGEMENT

The process for managing opportunities is similar to that defined for managing risks. For the purposes of the HNAABS Project, “opportunities” are unplanned, unforeseen, uncontrollable or unpredictable events that may have positive consequences. The steps that will be followed for opportunity management are shown in Figure 144.

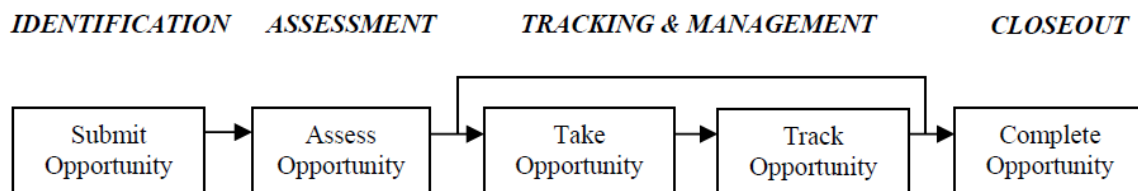

Figure 144. Opportunity management execution steps  
(From Defense Acquisition University 2011).

The management of an opportunity begins with its identification: any member of the Project Team may submit information about opportunities that arise during brainstorming, discussions, meetings or other project activities to the RMT. In the assessment phase, opportunities are analyzed by the RMT for their merits and impact to the project (if taken), as well as possible risks that may arise if the opportunity is realized. A cost-to-benefit comparison will be performed on every opportunity being assessed, to ensure that the supposed beneficial impact to the project is greater than the cost of taking action on that opportunity. Furthermore, the RMT will ensure that the project will not be subjected to significant risks just to take advantage of an opportunity.

Based on the assessment, the RMT will recommend the approach that will be used to handle the opportunity using any of the following strategies:

- **Exploit.** Take action to include the opportunity into the HNAABS project plan, ensuring that it occurs to achieve the positive outcome (i.e., probability of occurrence becomes 100%)

- Improve. Identify Enhancement Plans that seek to increase the probability of occurrence and/or increase the benefit of opportunities should they occur.
- Transfer. Allocate management to another party who is best able to handle the opportunity
- Accept. Do not take any additional action (allow opportunity to occur on its own)

The decision to take advantage of opportunities will rest on and be agreed upon by all relevant stakeholders. After a decision is made on which approach to use, the opportunity will be tracked and managed; the individual responsible for taking the opportunity will depend on the overall impact to the project (i.e., Project Lead for project-level impacts, RMT Lead for multi-team, Team Leads for team-level). Opportunity management will be facilitated by the RMT, who will report the status of opportunity actions (to be included in the Risk Meeting Report described in Section V.D.6.b) to the Project Team on a weekly basis and ensure that actions are taken in a timely manner to maximize benefits.

Towards the conclusion of the project, the RMT will compile a list of opportunities that were taken throughout the project, as well as information on their real impacts and benefits to the outcome of the project – this phase is known as closeout and is intended to coincide with the closeout date for risks (see Section V.D.3 of this document).

## **F. RISK MANAGEMENT TOOL**

Risks are very difficult to track without some form of documentation. Therefore, the RMT shall utilize management tools to provide a visual display of risks. In addition to using the “Risk Summary Form”, the RMT shall utilize Microsoft Word and Excel as extra tools that will be modified and/or customized to explicitly address risk uncertainty by prioritizing risks, developing mitigations, and tracking risks.

### **1. Using the Risk Summary Form**

Prior to using the Risk Summary Form to send Risks to RMT, the Risk Originator must gather appropriate information to document the potential problem (condition that

might affect the project), able to complete a good majority of the required fields of the Risk Summary Form, and if there is any questions concerning how to use the form, the Risk Originator shall contact the RMT Lead for assistance.

***a. Identifying a Risk***

Any project risk identified will be managed throughout the project. Knowledge pertaining to project risk is crucial to the formulation of mitigation plans and resolution of any issues that may result from the realization of such risks. In the ideal case, the Project Team is aware of what a risk is composed of, how it can affect the project and what efforts are needed to resolve it. It is particularly important to determine risks that are likely to affect the project early to avoid large negative impact to the project schedule and document the characteristics of any identified risks.

There are a lot of different ways to find risks on a project. However, due to the allocated timeline for the project, no attempt shall be made to identify all possible risks and the RMT will not mitigate all identified risks. Risks that have been discussed by the RMT, with documentation pertaining to any planned preventive and contingency measures that could minimize the effect of the risk event, shall be tracked and monitored by the RMT Lead utilizing the Word and Excel software tools.

***b. Create New Action Items***

After the RMT Lead has received a completed Risk Summary Form from a Project Team, the RMT Lead shall extract all risk information contained in the form and enter all captured risk data to the Excel spreadsheet being used to manage all project risks. The recording of risks with enough detailed information will go through a review to determine the risk criticality and importance to the project. A risk tracking number will be assigned to each risk item, and during the review, RMT lead shall be responsible to capture the discussed collaborative risk oversight and mitigation plan.

**c. Viewing/Updating an Action Items**

To view/update information on any captured Risks, as well as to display mitigation plans, a spreadsheet will be the main tool to use as a repository of risks, access all risks status updates, and manage risks.

**2. Weekly Risk Minutes**

A Word document will be used to provide some initial ideas on how to respond to capture risks and provide minutes of the weekly discussed risks assessment.

**G. PERFORMANCE MEASURES**

The following performance measurements in Table 89 are established for the risk management process. The RMT, as part of the HNAAB Project’s continuous improvement process, periodically evaluates these performance measures. Changes and additions are made on an "as needed" basis.







MEASURE	GOAL	FORMULA
Percent of risks changed to a lower severity level	Ensure that risks are mitigated to a lower severity level.	$\frac{\# \text{ of 'lower' risks}}{\# \text{ of all risks}}$
Percent of risks changed to a higher severity level	Ensure that risks are not negatively impeding the program’s progress.	$\frac{\# \text{ of 'higher' risks}}{\# \text{ of all risks}}$
Percent of risks with no change in severity level	Ensure that risks are not negatively impeding the program’s progress.	$\frac{\# \text{ of 'no change' risks}}{\# \text{ of all risks}}$
Percent of risks mitigated to target severity level	Ensure that risks are mitigated to their target severity level.	$\frac{\# \text{ of risk 'at target'}}{\# \text{ of all risks}}$
Percent of risks with documented mitigation plans	Ensure that risks are mitigated.	$\frac{\# \text{ of risk w/mitigation}}{\# \text{ of all risks}}$

Table 89. Risk management performance metrics (From Risk Management Plan Template and Guide 2009, 30).







THIS PAGE INTENTIONALLY LEFT BLANK

## APPENDIX D. LEGAL AND REGULATORY FRAMEWORK









### Local

Permit Name (Abbreviated Name)	Start End (Months)	Duration (Months)	Department	Appendix Link
Oahu Building Permit - PV, solar water heating, electric vehicle charging stations (City and County of Honolulu Building Permit)	0 - 2	2	Planning and Permitting – Building Division (Honolulu County) 	<a href="#">CCH-6</a>
Project District Application (Hawaii) (Hawaii-PDD)	27 - 34	7	Planning Department (Hawaii) 	<a href="#">H-15</a>
Plumbing Application (Hawaii-Plumbing)	34 - 35	1	Public Works - Building Division (Hawaii County) 	<a href="#">H-4</a>
Variance Application for County Streets (Hawaii) (Hawaii-Streets)	34 - 38	4	Public Works-Engineering Division (Hawaii County) 	<a href="#">H-11</a>
Grubbing Permit (Hawaii) (Hawaii-Grubbing)	38 - 39	1	Public Works-Engineering Division (Hawaii County) 	<a href="#">H-7</a>
Permit to Work Within the County-Right-of-Way (Hawaii) (Hawaii-ROW)	38 - 42	4	Public Works-Engineering Division (Hawaii County) 	<a href="#">H-8</a>
Stockpiling Permit (Hawaii) (Hawaii-Stockpile)	38 - 39	1	Public Works-Engineering Division (Hawaii County) 	<a href="#">H-10</a>

**State**

Permit Name (Abbreviated Name)	Start - End (Months)	Duration (Months)	Department	Appendix Link
Environmental Impact Statement/Environmental Assessment (S-EIS/EA)	0 - 18	18	Office of Environmental Quality Control (OEQC) 	<a href="#">S-5</a>
Pesticides Applicator Certification (S-Pest App)	0 - 1	1	Hawaii Department of Agriculture, Division of Plant Industry, Pesticides Branch 	<a href="#">S-17</a>
Biosolids Treatment Works Permit - Notice of Intent (NOI) (S-Biosolid)	18 - 27	9	Hawaii Department of Health, Environment Management Division, Wastewater Branch 	<a href="#">S-4</a>
Pesticides Experimental Use Permit (S-Pest Ex)	18 - 19	1	Hawaii Department of Agriculture, Division of Plant Industry, Pesticides Branch 	<a href="#">S-16</a>
Special Use Permit - over 15 acres (S-SUP-15ac+)	18 - 27	9	DBEDT, Land Use Commission 	<a href="#">S-33</a>
Underground Storage Tank (UST) Permit (S-UST)	18 - 36	18	Hawaii Department of Health (DOH) Environmental Management Division, Solid and Hazardous Waste Bran 	<a href="#">S-12</a>

## Federal

Permit Name (Abbreviated Name)	Start - End (Months)	Duration (Months)	Department	Appendix Link
Historic and Archaeological Resource Protection, Section 106 Process (F-106)	0 - 18	18	Department of Land and Natural Resources (DLNR) 	<a href="#">F-106</a>
National Environmental Policy Act (Fed-EIS/EA)	0 - 18	18	Council on Environmental Quality (CEQ) 	<a href="#">F-4</a>
Department of the Army (DA) Permit (Fed-DA)	18 - 22	4	U.S. Army Corps of Engineers, Regulatory Branch (USACE) 	<a href="#">F-1</a>
Incidental Take Permit, Endangered Species Act Section 10-FWS (Fed-Section10-FWS)	18 - 21	3	United States Fish and Wildlife Service (USFWS), Pacific Islands Fish and Wildlife Office 	<a href="#">F-11</a>
Incidental Take Permit, Endangered Species Act Section 10-NOAA (Fed-Section10-NOAA)	18 - 21	3	National Oceanic and Atmospheric Administration (NOAA), National Marine Fisheries Service (NMFS) 	<a href="#">F-8</a>
Incidental Take Statement, Endangered Species Act Section 7-FWS (Fed-Section7-FWS)	18 - 30	12	United States Fish and Wildlife Service (USFWS), Pacific Islands Fish and Wildlife Office 	<a href="#">F-10</a>
Incidental Take Statement, Endangered Species Act Section 7-NOAA (Fed-Section7-NOAA)	18 - 30	12	National Oceanic and Atmospheric Administration (NOAA), National Marine Fisheries Service (NMFS) 	<a href="#">F-7</a>
Letter of Authorization (LOA) or Incidental Harassment Authorization (IHA) (Fed-LOA)	18 - 19	1	National Oceanic and Atmospheric Administration (NOAA), National Marine Fisheries Service (NMFS) 	<a href="#">F-9</a>
National Park Service, Air Resources Division (Fed-NPS Air)	18 - 30	12	National Park Service, Air Resources Division 	<a href="#">F-6</a>

# Permit Schedule

● Federal 
 ● State 
 ● County

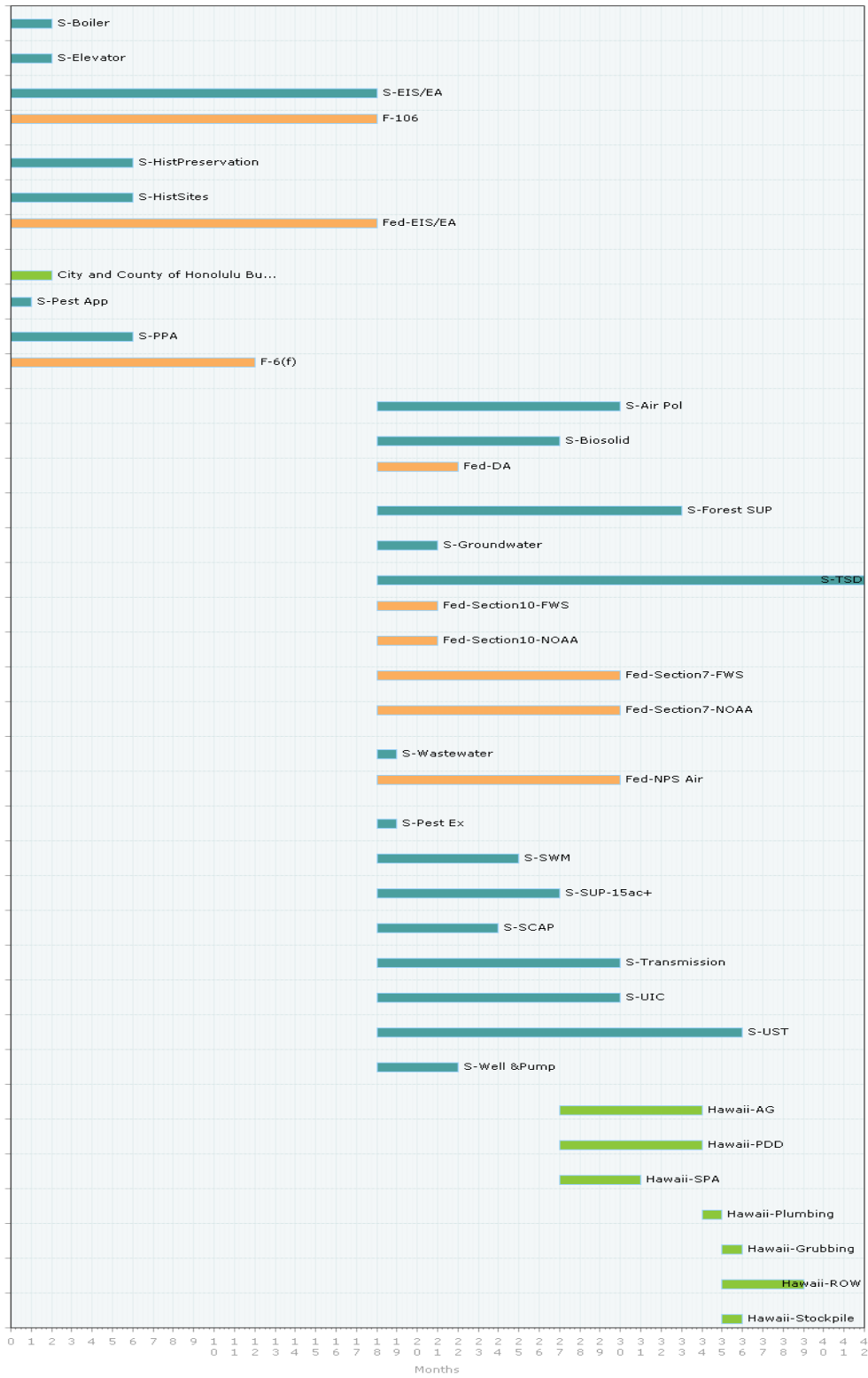

## APPENDIX E. TREATMENT STANDARDS FOR TOXIC WASTES

Source: (U.S. Environmental Protection Agency 2013)

Waste Code	Waste description and treatment/Regulatory subcategory 1	Regulated hazardous constituent	Wastewaters	Nonwastewaters
		Common name	Concentration 3 in mg/L; or Technology Code 4	Concentration 5 in mg/kg unless noted as "mg/L TCLP"; or Technology Code 4
K048	Dissolved air flotation (DAF) float from the petroleum refining industry.	Benzene	0.14	103.4
		Benzo(a)pyrene	0.061	
		bis(2-Ethylhexyl)phthalate	0.28	28
		Chrysene	0.059	3.4
		Di-n-butyl phthalate	0.057	28
		Ethylbenzene	0.057	10
		Fluorene	0.059	NA
		Naphthalene	0.059	5.6
		Phenanthrene	0.059	5.6
		Phenol	0.039	6.2
		Pyrene	0.067	8.2
		Toluene	0.08	10
		Xylenes-mixed isomers (sum of o-, m-, and p-xylene concentrations)	0.32	30
		Chromium (Total)	2.77	0.60 mg/L TCLP
		Chlorides (Total) 7	1.2	590
Lead	0.69	NA		
Nickel	NA	11 mg/L TCLP		
K049	Slop oil emulsion solids from the petroleum refining industry.	Anthracene	0.059	3.41
		Benzene	0.14	
		Benzo(a)pyrene	0.061	3.4
		bis(2-Ethylhexyl)phthalate	0.28	28
		Carbon disulfide	3.8	NA
		Chrysene	0.059	3.4
		2,4-Dimethylphenol	0.036	NA
		Ethylbenzene	0.057	10
Naphthalene	0.059	5.6		

		Phenanthrene	0.059	5.6
		Phenol	0.039	6.2
		Pyrene	0.067	8.2
		Toluene	0.08	10
		Xylenes-mixed isomers (sum of o-, m-, and p-xylene concentrations)	0.32	30
		Cyanides (Total) 7	1.2	590
		Chromium (Total)	2.77	0.60 mg/L TCLP
		Lead	0.69	NA
		Nickel	NA	11 mg/L TCLP
K050	Heat exchanger bundle cleaning sludge from the petroleum refining industry.	Benzo(a)pyrenePhenol	0.0610.039	3.46.2
		Cyanides (Total) 7	1.2	590
		Chromium (Total)	2.77	0.60 mg/L TCLP
		Lead	0.69	NA
		Nickel	NA	11 mg/L TCLP
K051	API separator sludge from the petroleum refining industry.	AcenaphtheneAnthracene	0.0590.059	NA3.4
		Benz(a)anthracene	0.059	3.4
		Benzene	0.14	10
		Benzo(a)pyrene	0.061	3.4
		bis(2-Ethylhexyl)phthalate	0.28	28
		Chrysene	0.059	3.4
		Di-n-butyl phthalate	0.057	28
		Ethylbenzene	0.057	10
		Fluorene	0.059	NA
		Naphthalene	0.059	5.6
		Phenanthrene	0.059	5.6
		Phenol	0.039	6.2
		Pyrene	0.067	8.2
		Toluene	0.08	10
		Xylenes-mixed isomers (sum of o-, m-, and p-xylene concentrations)	0.32	30
		Cyanides (Total) 7	1.2	590
		Chromium (Total)	2.77	0.60 mg/L TCLP
		Lead	0.69	NA
		Nickel	NA	11 mg/L TCLP

K052	Tank bottoms (leaded) from the petroleum refining industry.	BenzeneBenzo(a)pyrene	0.140.061	103.4
		o-Cresol	0.11	5.6
		m-Cresol (difficult to distinguish from p-cresol)	0.77	5.6
		p-Cresol (difficult to distinguish from m-cresol)	0.77	5.6
		2,4-Dimethylphenol	0.036	NA
		Ethylbenzene	0.057	10
		Naphthalene	0.059	5.6
		Phenanthrene	0.059	5.6
		Phenol	0.039	6.2
		Toluene	0.08	10
		Xylenes-mixed isomers (sum of o-, m-, and p-xylene concentrations)	0.32	30
		Chromium (Total)	2.77	0.60 mg/L TCLP
		Cyanides (Total) 7	1.2	590
		Lead	0.69	NA
		Nickel	NA	11 mg/L TCLP
K169	Crude oil tank sediment from petroleum refining operations.	Benz(a)anthracene	0.059	3.4
		Benzene	0.14	10
		Benzo(g,h,i)perylene	0.0055	1.8
		Chrysene	0.059	3.4
		Ethyl benzene	0.057	10
		Fluorene	0.059	3.4
		Naphthalene	0.059	5.6
		Phenanthrene	0.059	5.6
		Pyrene	0.067	8.2
		Toluene (Methyl Benzene)	0.08	10
		Xylene(s) (Total)	0.32	30
K170	Clarified slurry oil sediment from petroleum refining operations.	Benz(a)anthraceneBenzene	0.0590.14	3.41
		Benzo(g,h,i)perylene	0.0055	1.8
		Chrysene	0.059	3.4
		Dibenz(a,h)anthracene	0.055	8.2
		Ethyl benzene	0.057	10
		Fluorene	0.059	3.4

		Indeno(1,3,4-cd)pyrene	0.0055	3.4
		Naphthalene	0.059	5.6
		Phenanthrene	0.059	5.6
		Pyrene	0.067	8.2
		Toluene (Methyl Benzene)	0.08	10
		Xylene(s) (Total)	0.32	30
K171	Spent hydrotreating catalyst from petroleum refining operations, including guard beds used to desulfurize feeds to other catalytic reactors (this listing does not include inert support media).	Benz(a)anthraceneBenzene	0.0590.14 0.059	3.410 3.4 10
		Chrysene Ethyl benzene	0.057	
		Naphthalene	0.059	5.6
		Phenanthrene	0.059	5.6
		Pyrene	0.67	8.2
		Toluene (Methyl Benzene)	0.08	10
		Xylene(s) (Total)	0.32	30
		Arsenic	1.4	5 mg/L TCLP
		Nickel	3.98	11.0 mg/L TCLP
		Vanadium	4.3	1.6 mg/L TCLP
		Reactive sulfides	DEACT	DEACT
K172	Spent hydrorefining catalyst from petroleum refining operations, including guard beds used to desulfurize feeds to other catalytic reactors (this listing does not include inert support media.).	BenzeneEthyl benzene		
		Toluene (Methyl Benzene)	0.140.57 0.080	
		Xylene(s) (Total)	0.32	1010 10 30

## **APPENDIX F. HNAABS RISK ASSESSMENT**

### **A. INTRODUCTION**

#### **1. Purpose**

The purpose of this risk assessment was to evaluate and manage HNAABS risks. This document presents the Risk Management Team's (RMT) proactive risk assessment of Hawaii Naval Aviation Algal Biofuel System (HNAABS) project and ensured all capstone members understood the risks within the HNAABS project. Additionally, with the RMT's effort to obtain and attempt to document risks that might adversely impact the project, this document is being released to serve as early historical proactive risk assessment data for the next Naval Postgraduate School (NPS) cohort to continue the HNAABS project.

#### **2. Scope**

The scope of this risk assessment was to collaborate with all HNAABS Teams to properly assess found risks, define both the likelihood and consequence of the risk identified in each phase, and continue risk mitigation/management throughout the project.

### **B. RISK ASSESSMENT APPROACH**

The risk assessment methodology and approach was conducted using the guidelines/instructions from the released Risk Management Plan (RMP). Risk(s) were identified in the Early-Preparation Phase, Research Phase, and Development Phase of the HNAABS project. Each team that reported risk used Figure 145 and Figure 146, as shown below, to assess the levels of different risks.

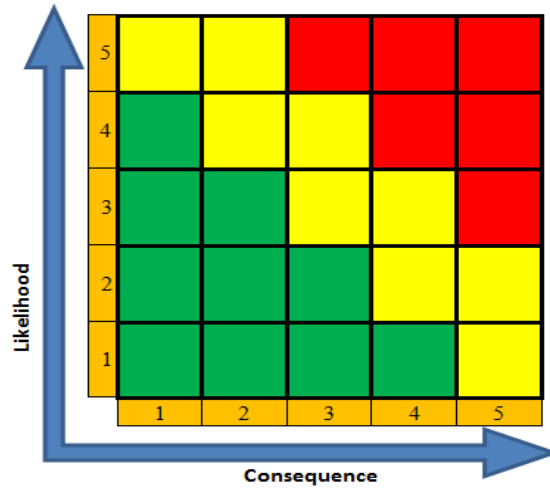

Figure 145. Assessment matrix.

<b>High</b>	Likely to cause significant serious disruption of schedule, increase in cost, or degradation of performance even with special contractor emphasis and close government monitoring.
<b>Moderate</b>	Can potentially cause some disruption of schedule, increase in cost, or degradation of performance. However, special contractor emphasis and close government monitoring will probably be able to overcome difficulties.
<b>Low</b>	Has little potential to cause disruption of schedule, increase in cost, or performance. Normal contractor effort and normal government monitoring will probably be able to overcome difficulties.

Figure 146. Risk level descriptions.

### C. RISK ASSESSMENT PROCESS

This section details the risk assessment process performed throughout the project. The process was aligned to the NPS academic calendar: Early-Preparation Phase, Research Phase, and Development Phase (Figure 147).

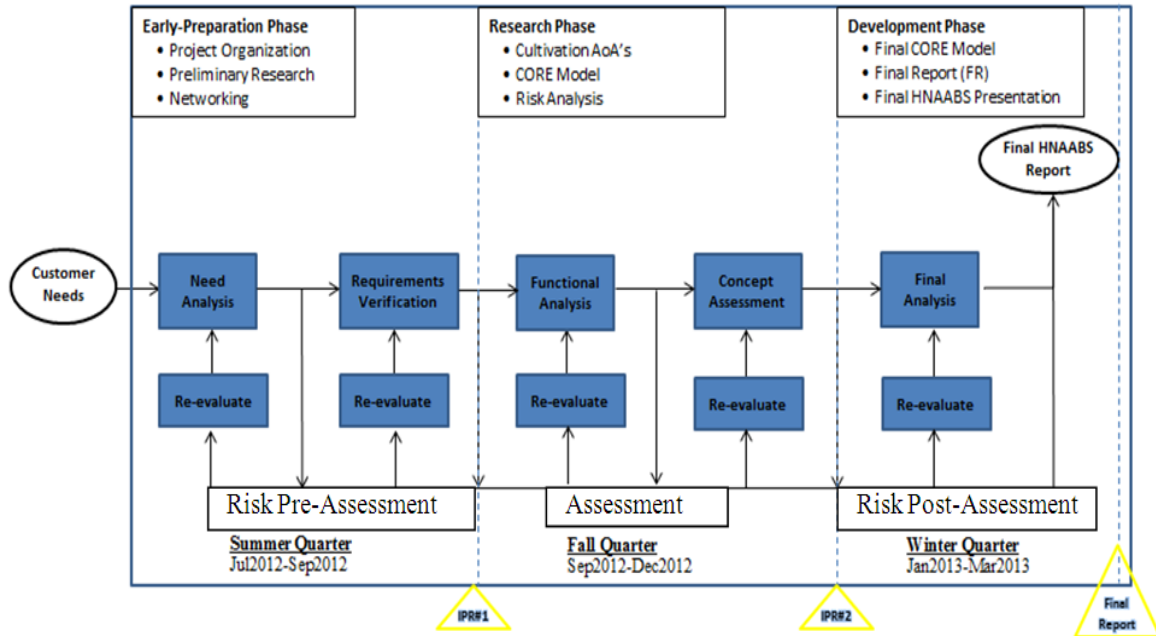

Figure 147. HNAABS systems engineering/project cycle model.

### 1. Early-Preparation Phase (Summer Quarter)

During the Early-Preparation Phase, shown in Figure 148, the initial “risk pre-assessment” provided an early evaluation of possible present/future risks for the HNAABS Cultivation and Refinement systems. The risk findings, at this time, were used to focus on early-concept/research planning on what/how to grow and harvest algae, examine possible ways to extract oil from harvested algae, and explore ideas to refine oil to produce bio-kerosene, including focus on early-concept/research on environmental and associated costs concerns.

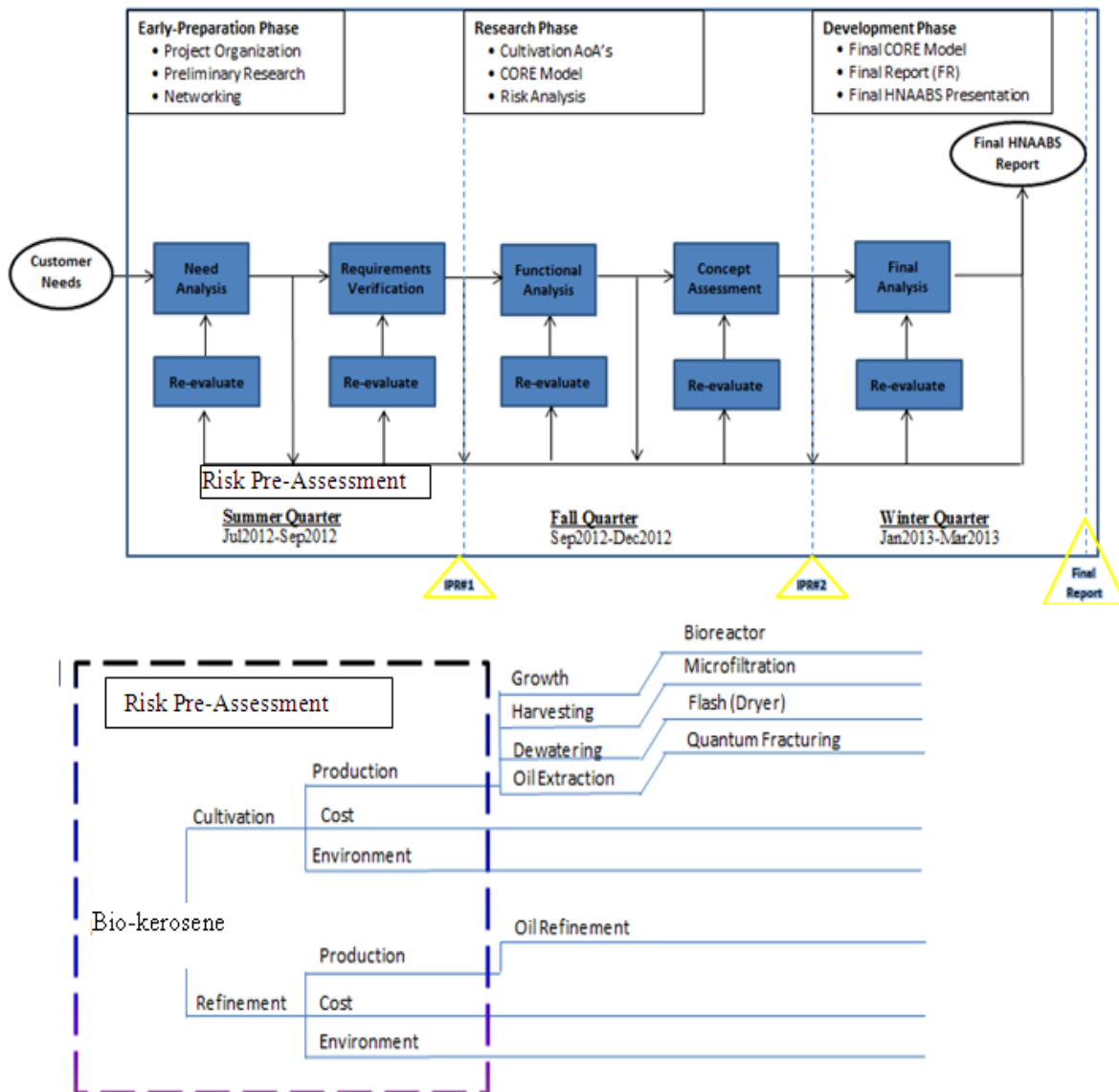

Figure 148. Risk pre-assessment.

The illustration, as shown in Figure 4, depicts how early on project conception costs and environment are major activities that affect both Cultivation and Refinement systems. HNAABS Project Teams were defined to limit redundancy and rework. The roles of each team (Cultivation Team, Refinement Team, Cost Team, and Environmental Team) were clearly assigned to establish distinct focus on capturing risks – i.e., reference the RMP to clearly view the risk management organization that discuss the roles of each team, as a risk originator, and responsibilities of identifying project risks and/or identifying candidate mitigation approaches.

***a. Tracked Risks***

As the HNAABS Project Team continued to identify early-design requirements, early risk submissions were sent to RMT using the Risk Summary Form to support to document and assess risks. During a regular capstone weekly meeting, the early-risk submissions were reviewed by the Project Manager (PM) and the HNAABS Project Team to assess/review each of the written entrant mitigation methods. After review of which risks to mitigate and receive concurrence by all during the meeting, risk owners were assigned and each risk was given a risk tracking number in accordance with the guidance and instructions from the RMP. Figure 149 illustrates the various risks and their originators.

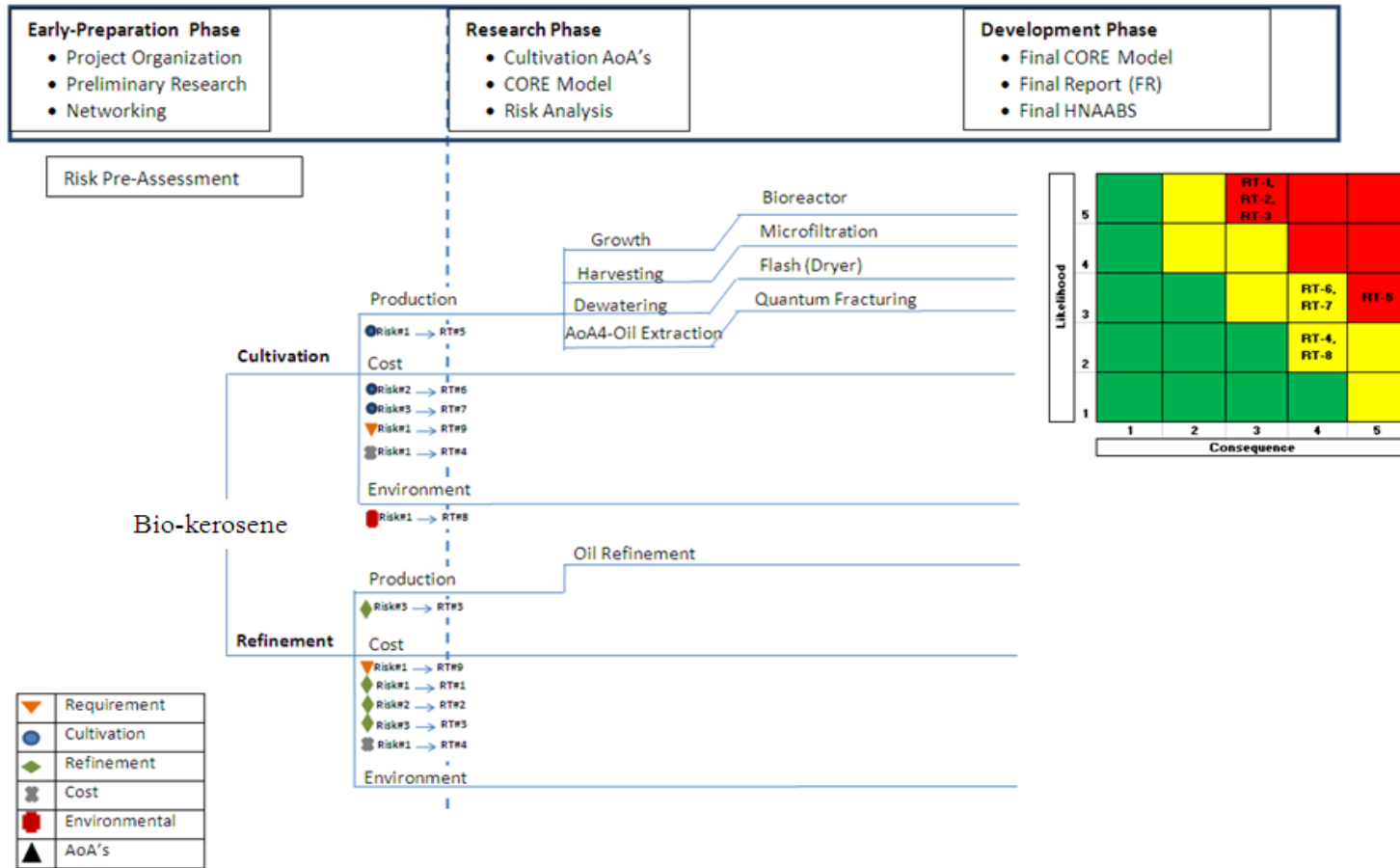

Figure 149. Early-risk submission: matrix/tracking number.

Each risk tracked items correspond to the given color/shape associated with each team that submitted the risk and pointed out the early risks that presented possible impact(s) to the project. All of RT-1 through RT-9 risks with mitigation plan(s) received the attention of each HNAABS Project Team for agreement on mitigation plans. To support the early risks and appropriately schedule each team to focus on risks, the Integrated Master Schedule (IMS) was utilized – i.e., each HNAABS Project Team was assigned schedule due dates on the work breakdown structures to continue pursuit of assessing overall project risks. The full list of risks that received a “Risk Tracking” number can be found in Appendix G, Tracked Risks.

The risks that needed to be addressed through research and mitigation were recorded risks that received high points on the DOD risk matrix. These reported risks were:

- Submitted by Refinement. (RT-1) Hydrocracking power requirement can be expensive,
- Submitted by Refinement. (RT-2) Non-usable waste byproduct disposal,
- Submitted by Refinement. (RT-3) If an existing refinery cannot be converted to meet KPPs, then a new refinery may need to be built, and
- Submitted by Cultivation. (RT-5) Cultivation Technical Maturity Risk.

From early on, risk submission tracked as RT-1 was considered high risk due to the possible intensive need for hydro-cracking that could exceed/overburden Hawaii’s current power infrastructure. This could increase the cost and time required to convert extracted oil into bio-kerosene since research indicated, at the moment, industrial scale operation and infrastructure of a commercial scale bio-oil refinement does not exist. The vast majority of available data only indicated small-scale bio-oil refinement was operational. To understand the risk level and affects, during this phase, the refinement team expanded their research to the next level to determine Hawaii’s power consumption restrictions, associated costs with the variations of power consumption, and determine

internal power generation options and/or need to acquire the required delta to maintain/increase efficiency and ultimately reduce costs.

The second high risk submission was RT-2 due to the possible waste produced within the refinement of extracted oil to bio-kerosene. It was predicted that waste produced and strict Hawaii's environmental laws would incur additional cost to remove and manage the waste from the refinery. To comprehend what would satisfy the requirements of the HNAABS Refinement system, a study was done to define the amount of allowable waste output, identify what waste products are recyclable and disposable, and define environmental/health regulations required in breaking ground to produce a Waste Management Facility.

The third high risk submission was RT-3 due to the possible difficulty of meeting Key Performance Parameters (KPPs) if there were no existing bio-oil refineries in Hawaii and would require a new refinery to be built. The refinement team's approach to limit this risk was to determine what refineries exist in Hawaii, determine existing refineries specifications – e.g., size and fuel/bio-kerosene output, and perform trade-off analysis of existing refineries versus building a new refinery, including defining the TRL level of a bio-refinery.

The last high risk was RT-5 due to the industrial scale operation and infrastructure of commercial scale bio-oil cultivation plant not existing in Hawaii. The vast majority of available data available found were from various experimental small-scale cultivation systems, including extraction of oil, from diverse algal species. To understand the risk level and affects, during this phase, the cultivation team expanded their research to determine the technical maturity of algal cultivation system and define a cultivation method for Hawaii to support a suitable cultivation level of production/operation.

***b. Accepted Risks***

After assessing the other risk submissions and due to the nature of the risks, the RMT recognized that these risks are uncontrollable and cannot be influenced.

Acceptances of these risks were given to these unique risks (Figure 150). Details of risks that received a “Risk Tracking” number can be found in Appendix H, Accepted Risks.

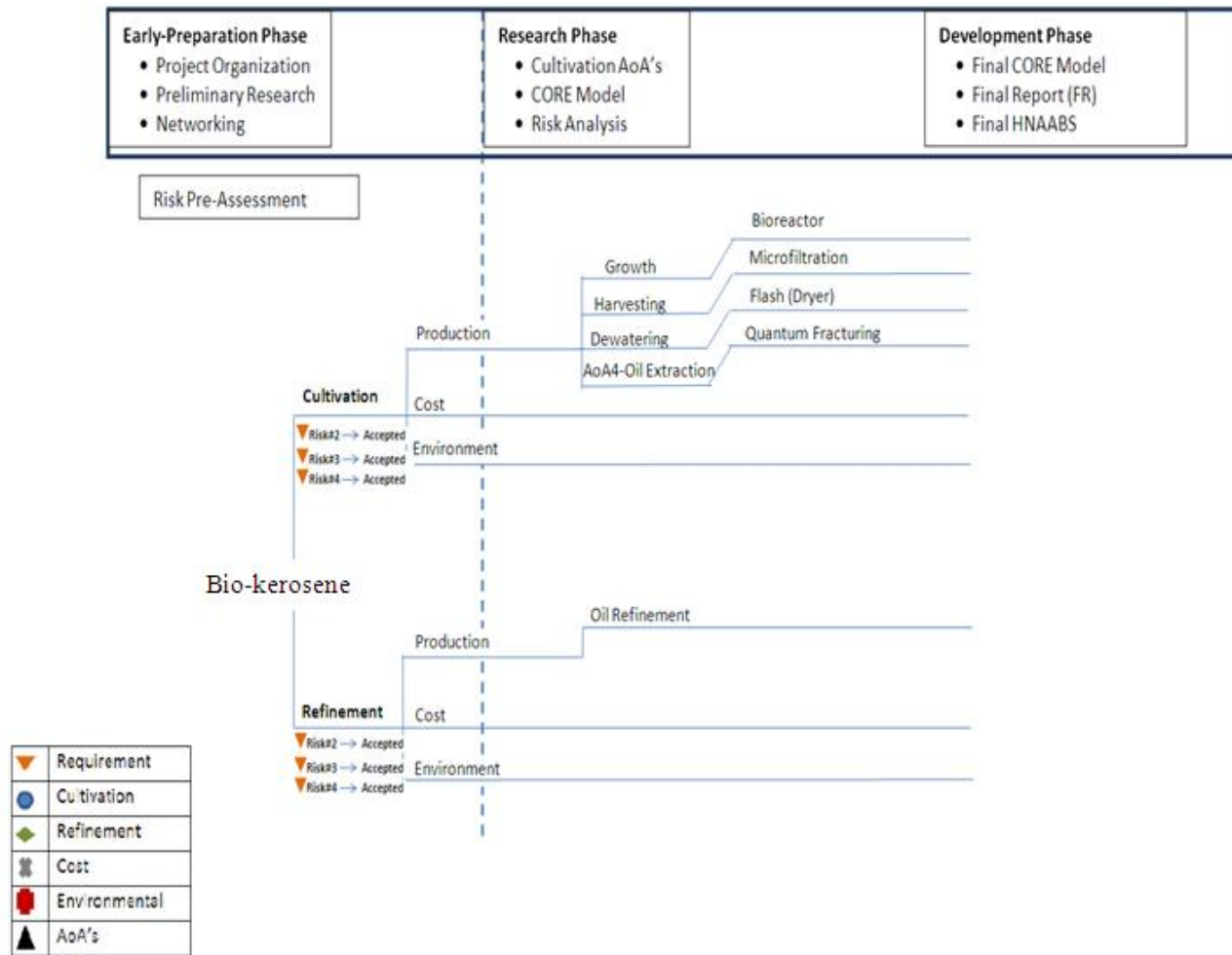

Figure 150. Early-risk submission: accepted risk.

The RMT received three risk submissions, each were analyzed, and determined to accept the consequences if the risks occurs. These reported risks that received acceptance were:

- Submitted by Requirement. (Risk #2) HNAABS Schedule Risk Due to Late Deliverables from Sub-teams,
- Submitted by Requirement. (Risk #3) HNAABS will be affected by Trade-Wind & Rainfall, and
- Submitted by Requirement. (Risk #4) HNAABS will be affected by trade-winds.

After the RMT's complete analysis of Risk#2, the IMS schedule risk due to late deliverables from sub-teams was predictable to occur. During the early-preparation phase, due to the amount of research and tasking required of each sub-teams to perform, the RMT anticipated late deliveries of IMS schedule due dates. The IMS was created with a goal of meeting the final project deliverables. To support and manage the changes that were required in the IMS schedule, a responsible person was assigned to release updates to IMS, collaborate per each team to acquire status updates, and track/monitor project deliverables till project completion.

Due to the location of the Hawaiian Islands, the weather conditions was a major concern which produced Risk #3 and Risk #4 submissions to the RMT. However, the RMT recognized that these risks associated with weather conditions in Hawaii cannot be influenced. The Islands are comprised of many micro-climates such that the landscape of a particular island can change from desert like conditions to tropical rain forest over a short distance. The RMT determined these were risks acceptable for developing an algal based biofuel system in the state of Hawaii.

## **2. Research Phase (Fall Quarter)**

As the project enters the Research Phase, the HNAABS resources were re-allocated to form specific teams, refer to Appendix K, to focus on cultivation Analysis of Alternatives (AoA) on algal growth, harvesting, dewatering, and oil extraction. While

each cultivation AoA teams continued to pursue investigation/research analysis of a viable cultivation system, the RMT revised the overall way of capturing new risks and continued to acquire status updates of tracked risks from various teams. Figure 151 shows new risks submissions to RMT.

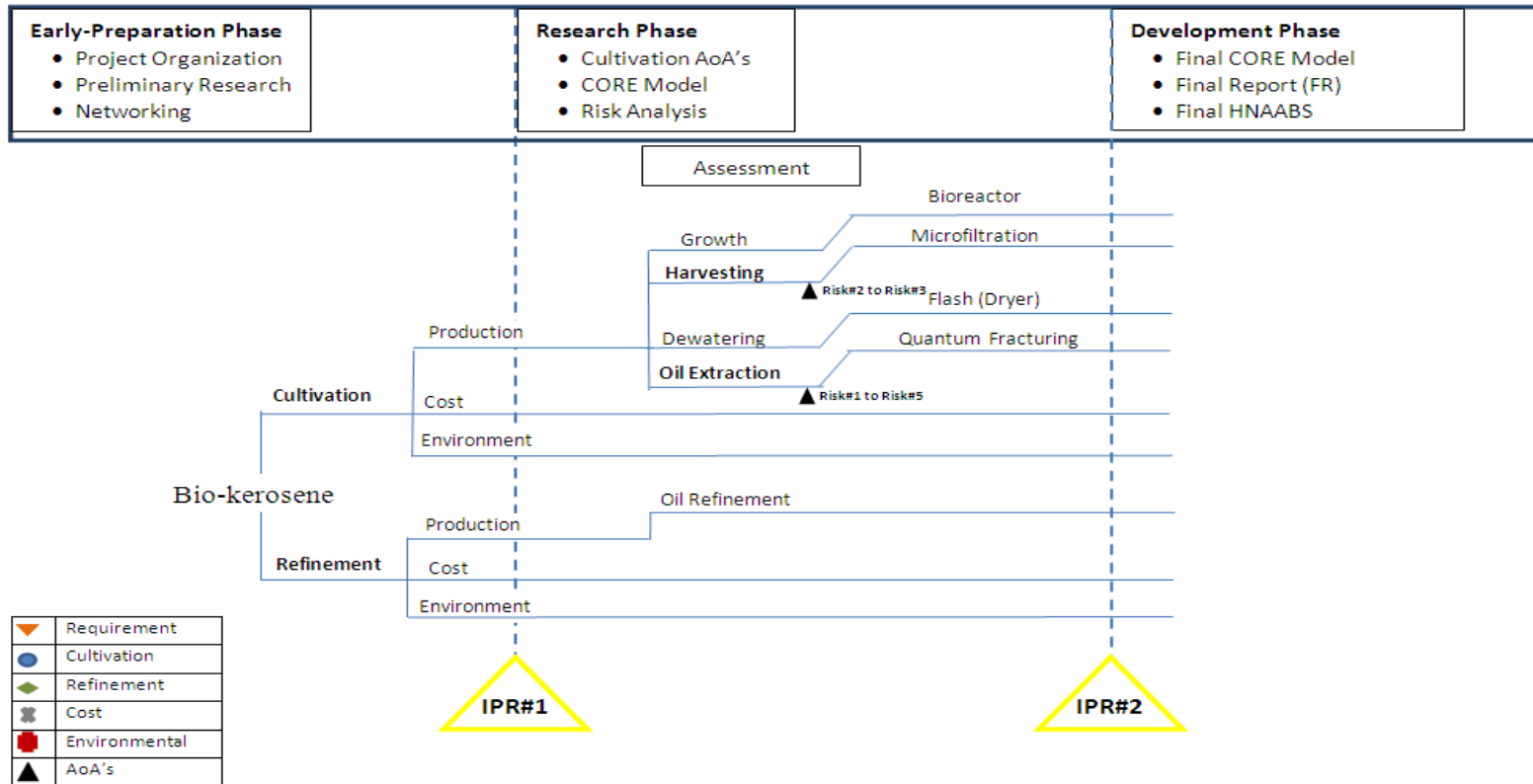

Figure 151. Risk submissions during AoA's.

To have a pre-emptive approach to capture new risks, members of the RMT on each of the AoA teams were utilized to proactively identify risks, communicate with team leads, and if necessary, submit new risks to facilitate attention of key risks that may impact the project and/or individual teams. During this phase, the RMT were able to receive nine risk submissions: three submissions were from the RMT POC for harvesting (AoA#2), one submission was from the RMT POC for oil extraction (AoA#2), and five submissions were from oil extraction (AoA#4 team). The full list of AoA risks submissions can be found in APPENDIX I – AOA RISK SUBMISSION.

- Submitted by Julie Martin (RMT POC) for Cultivation AoA#2. (Risk-1) Costs Associated with use of Chemicals to Aid in Flocculation Process
- Submitted by Julie Martin (RMT POC) for Cultivation AoA#2. (Risk-2) Use of Chemicals to Aid in Flocculation Process
- Submitted by Julie Martin (RMT POC) for Cultivation AoA#2. (Risk-3) TRL Level of Non-Chemical Flocculation Processes
- Submitted by Cultivation AoA#4. (Risk-1) Global DME Capacity
- Submitted by Cultivation AoA#4. (Risk-2) Algae nutrients
- Submitted by Cultivation AoA#4. (Risk-3) Unknown Impact on Oil Quality with Ultrasonic Lysing
- Submitted by Cultivation AoA#4. (Risk-4) Power and Scalability for Ultrasonic Lysing
- Submitted by Cultivation AoA#4. (Risk-5) Ultrasonic Lysing and its dependency on other Processes
- Submitted by Mark Relova (RMT POC) for Cultivation AoA#4. (Risk-1) Use of Hexane in Oil Extraction may cause Issues

Nine new risk submissions were not given a risk tracking number. All the received risks from AoA#2 and AoA#4 team were discussed during the Risk meeting. It was suggested to collect all possible risks for further re-assessment when final analyses of alternatives reports are released. It was expected that the analysis of alternatives reports would describe the process of a comparative cost, performance, and environmental impact/risk to determine the appropriate system to integrate and recommend the final findings as an entire algal biofuel system of systems.

During the Research Phase, eight tracked risks, shown in Figure 5, were monitored and the RMT focused attention on the research being performed by all teams

to address any changes/updates to the tracked risks and/or mitigation plans. Weekly risk meetings were held by RMT personnel to discuss if there are tracked risks being mitigated and/or ready for closure; however, since the analysis of alternatives were being performed and final AoA reports had not been released, it was anticipated that the final findings needed to perform risk closure would be available during the Development Phase.

### **3. Development Phase (Winter Quarter)**

As with any unproven concept, there were many types of risks that may potentially interfere with a successful completion of a project. The lessons learned from the past two semester quarters and from continuous comprehensive analysis/assessment (e.g., Analysis of Alternatives) ensure adequate research data were available during the Development Phase. During this last phase, all piece parts of obtainable data were uniquely integrated to produce a recognizable HNAABS design solution. Risks defined from previous two phases were appropriately updated to include the severity of the risks, additional new, and risk closures were performed.

#### ***a. Development Phase Risk Submissions***

As the HNAABS Project Team carry-on to construct an HNAABS design solution to meet the allotted capstone project schedule, risk identification continued to determine that is/are likely to affect the project, and to document the characteristics of found risks, risk submissions continued to be sent to the RMT, refer to Figure 152.

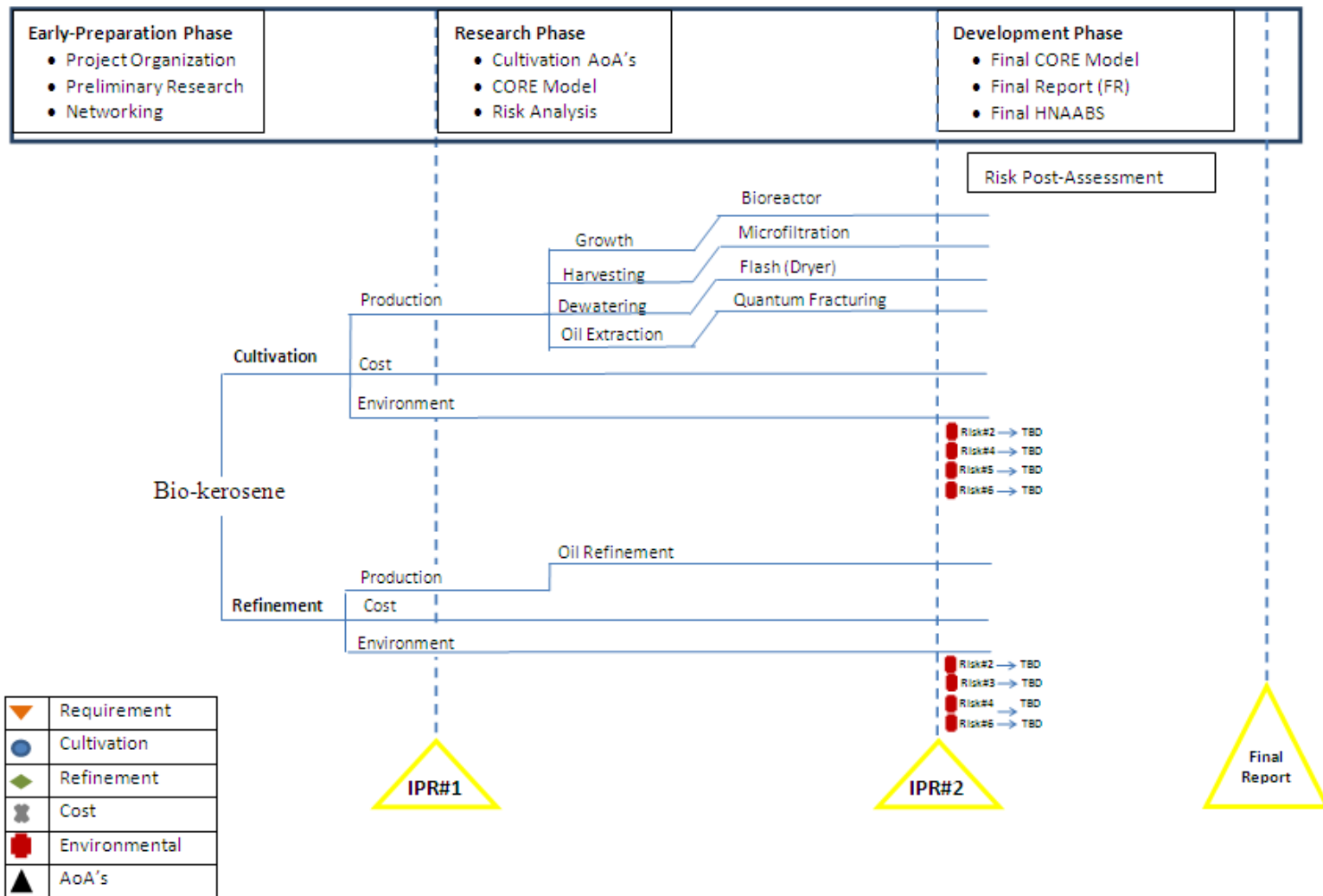

Figure 152. Post-AoA's risk submissions.

The environmental team had captured five new risks. These risks were sent to the RMT to document and pursue risk management. The risks that have been identified by Environment team were:

- (Risk-2) Regulation and/or statute changes,
- (Risk-3) Keeping air emissions at acceptable levels,
- (Risk-4) Untreated waste water discharge,
- (Risk-5) Consuming too much water in the algae biofuel production region, and
- (Risk-6) Conflicts of land use.

Mitigation plans were developed for all these new risk submissions; however, due to the short allotted time left, the RMT did not continue to mitigate these risks. These risks have been illustrated as to be determined (TBD) until additional information is available. The RMT suggested that the captured risks could be used by the next capstone team to continue risk management and develop contingency plans that can address the risks identified as the project advances out of concept design. The full risks that received as TBD can be found in Appendix J.

***b. Risk Status***

As depicted in Figure 153, after the Development Phase commenced and AoA reports were released, it follows logically that the risks being tracked/monitored showed a significant status change compared to the previous two quarters. The previous critical high risks were downgraded due to the results of work performed by each assignee to continue the attempt to mitigate the known risks to an appropriate level and eventually leads to risk closure. As illustrated, six risks have received concurrence for the RMT to continue to log as being mitigated, three risks were kept open, and the majority of the risks that were likely to occur, but proved through performed analysis are no longer potential project risks, were all closed.

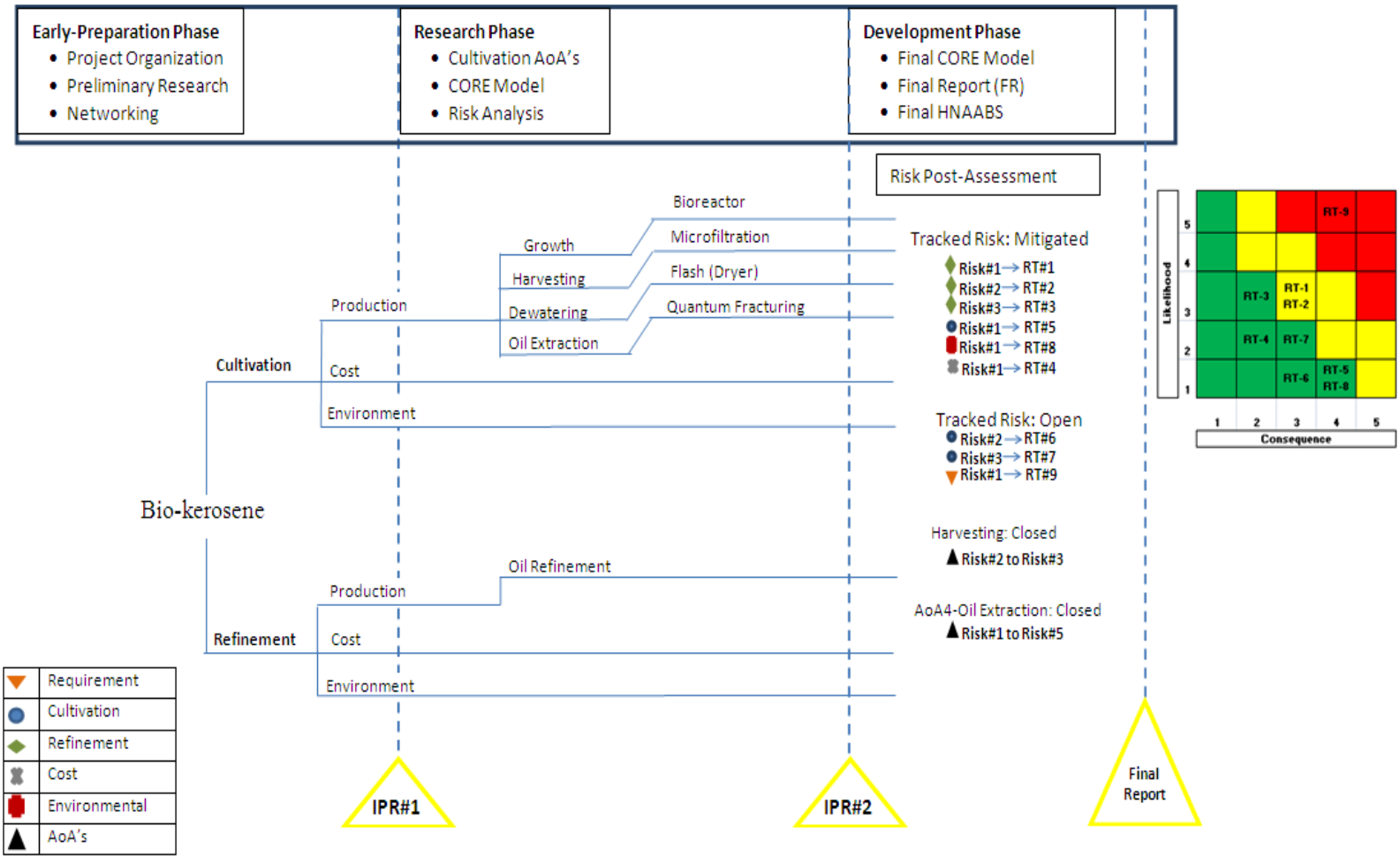

Figure 153. Risk reviewed.

**c. Risks Mitigated**

With assistance from RMT resources working with their pre-assigned HNAABS Project Team, a comprehensive assessment of the tracked risk was performed and was the final phase in the execution of the risk management process. The results produced six risks to be mitigated and each of the risk’s previous likelihood and consequence were reviewed during the RMT’s meetings to determine what the new risk level, at present, after mitigation has been performed. The full list of risks that received a “Risk Tracking” number, including viewing present likelihood and consequence level, can be found in Appendix G.

(1) **Refinement Risks Mitigated.** The refinement team completed their assessment and indicated RT-1 through RT-3’s mitigation plans have been performed to an appropriate level of likelihood and consequence. This outcome of the refinement analysis produced an up-to-date risk level submission, and the status of each risk has been downgraded respectively to show the final risk level, refer to Figure 154.

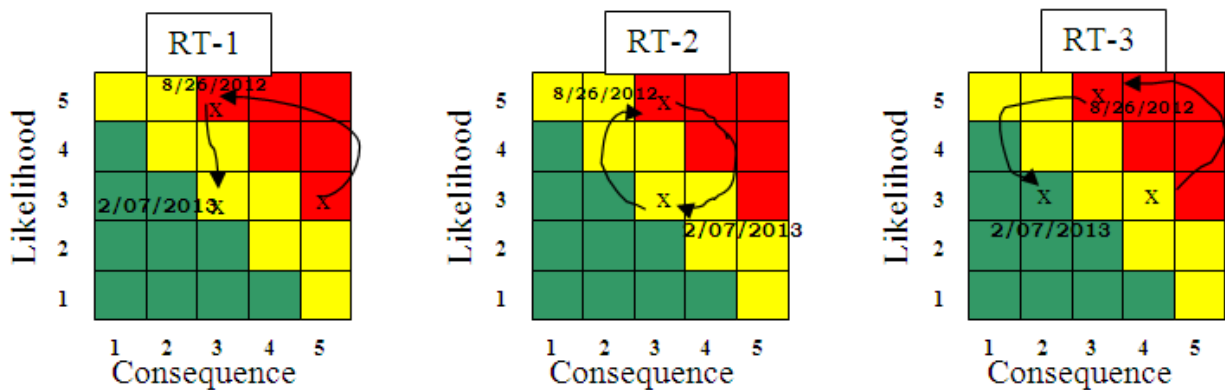

Figure 154. DOD matrix: refinement final risk outcome.

During a recent RMT meeting, the detailed actions performed by refinement team were discussed. From the outcome of the meeting, it was agreed upon that the downgrade of the likelihood and consequence was valid. Instead of RT-1 and RT-2 being likelihood of 5 and consequence of 3, the present new risk level for both is now a likelihood of 3 and consequence of 3. Even though RT-1 and RT-2’s final risk

outcome was downgraded to a medium level, and at present, we (RMT) illustrated these two risks were mitigated. However, both of these risks can most likely incur difficulty still since there is heavy reliance on availability of technology that can cause a significant risk cost over-runs. Therefore, there is a need for the next capstone group who will lead beyond what our group performed should continue to monitor these risks since they can also cause havoc on a projects' schedule.

Due to the current findings that indicate a benchmark can be performed on an operational bio-refinery in Geismar, LA and adequate data have been collected to pursue retrofit a refinement system, the RT-3 being likelihood of 5 and consequence of 3 from previous quarter is now, at the moment, a likelihood of 3 and consequence of 2 this quarter. This is a low level risk, and after our meeting, concurrence was given to illustrate this risk had been mitigated.

(2) **Cost Risks Mitigated.** The cost team completed their assessment and indicated RT-4 could be downgraded to an appropriate level of likelihood and consequence level. This outcome of the cost analysis produced an up-to-date risk level submission, and the status of the risk has been downgraded respectively to show the final risk level, refer to Figure155.

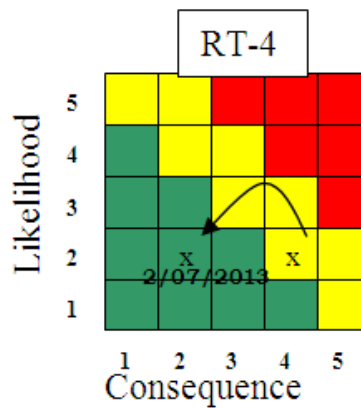

Figure 155. DOD matrix: cost final risk outcome.

The detailed actions performed by the cost team were discussed. From the outcome of the meeting, it was agreed upon that the downgrade of the likelihood and consequence was valid. The RT-4 being likelihood of 2 and consequence

of 4 from previous quarter is now, at the moment, a likelihood of 2 and consequence of 2 this quarter. This is a low level risk, and at present, the given agreement was to illustrate this risk as mitigated since the current recommendation received from the risk owner was to utilize hybrid/retrofit approach to acquire facilities –i.e., no need to purchase/build new facilities and govt. entity need to collaborate to form a partnership with corporate in Hawaii to ensure needed facilities is/are available.

(3) **Cultivation Risks Mitigated.** Cultivation team completed their assessment and indicates RT-5 could be downgraded to an appropriate level of likelihood and consequence. This outcome of the cultivation analysis produced an up-to-date risk level submission, and the status of the risk has been downgraded respectively to show the final risk level, refer to Figure 156.

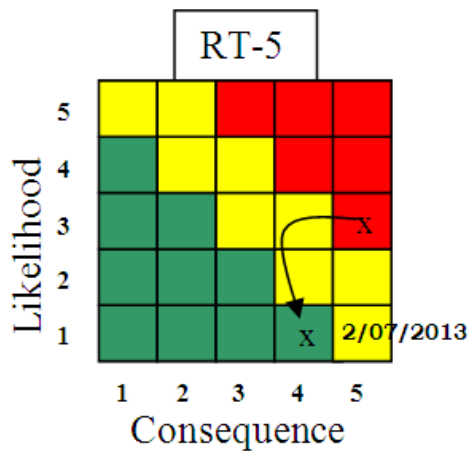

Figure 156. DOD matrix: cultivation final risk outcome.

As the RMT meeting progressed onward, the detailed actions performed by cultivation team were discussed. From the outcome of the meeting, it was agreed upon that the downgrade of the likelihood and consequence was valid. The RT-5 being likelihood of 3 and consequence of 5 from previous quarter is now, at the moment, a likelihood of 1 and consequence of 4. This is a low level risk and agreement was given to illustrate this risk had been mitigated this quarter. However, there is a need for the next capstone group who will lead beyond what our group performed should continue to monitor this risk since there is a heavy reliance on availability of technology that can cause a significant risk cost over-runs.

(4) **Cultivation/Environmental Risks Mitigated.** The Cultivation and Environmental teams completed their assessment and indicated RT-8 could be downgraded to an appropriate level of likelihood and consequence. This outcome of the environmental analysis produced an up-to-date risk level submission, and the status of the risk has been downgraded respectively to show the final risk level, refer to Figure 157.

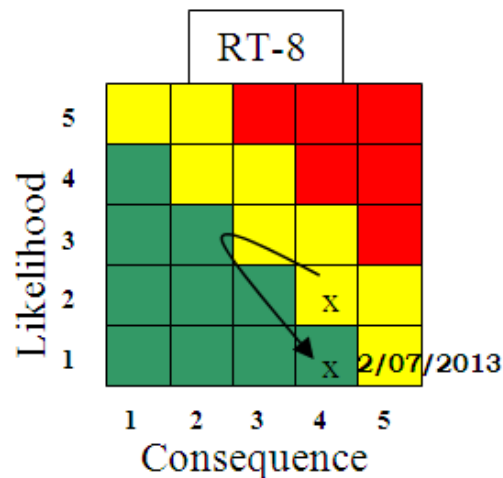

Figure 157. DOD matrix: environmental final risk outcome.

Last but not least, during the recent RMT meeting, the detailed actions performed by the cultivation and environmental teams were discussed. From the outcome of the meeting, it was agreed upon that the downgrade of the likelihood and consequence was valid. The RT-8 being likelihood of 2 and consequence of 4 from previous quarter is now, at the moment, a likelihood of 1 and consequence of 4 this quarter. This is a low level risk and agreement was given to illustrate this risk had been mitigated. Going forward, the current RMT recommendation for the next capstone team who will lead beyond what our group performed, to properly remove invasive algal species being introduced to Hawaii's environment, is to only use algae species not on the banned algal list.

**d. Risks Open**

As RMT meeting continued on reviewing data sent by cultivation team lead to support the final risk assessment, the result produced three risks to bring up to date as “open items.” The likelihood and consequence levels from previous quarter were reviewed by RMT to determine the new risk level. The full list of risks that received “Risk Tracking” number, including viewing present likelihood and consequence level, can be found in Appendix G, Tracked Risks.

(1) **Cultivation Risks Open.** The cultivation team completed their assessment and indicated RT-6 and RT-7’s appropriate level of likelihood and consequence level can be downgraded to a low level risk; however, there is a need for the next capstone group who will lead beyond what our group performed should continue risk management process until mitigated. The outcome of the cultivation analysis produced an up-to-date risk level submission, and the status of each risk has been downgraded respectively to show the final risk level, refer to Figure 158.

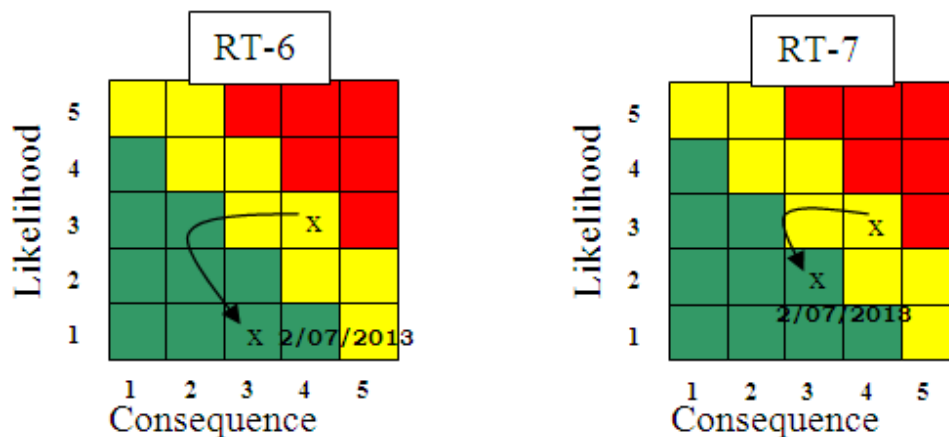

Figure 158. DOD matrix: cultivation risks open.

During a recent RMT meeting, the detailed actions performed by cultivation team were discussed. From the outcome of the meeting and data received, it was agreed upon that the downgrade of the likelihood and consequence level for RT-6 and RT-7 was valid.

The RT-6 being likelihood of 3 and consequence of 4 from previous quarter is now, at the moment, a likelihood of 1 and consequence of 3 this

quarter. It was agreed upon that this risk will be kept open and update the excel database to document the recommended use of photo-bioreactor (PBR) that cuts the land requirements in half as opposed to the open pond method. However, as the project is handed over to the next capstone group, to ensure consistency and confirm the data documented is current, there is a need to evaluate PBR's social acceptance in the region and continue risk management to double check the land estimate, including available land, required for a photo-bioreactor.

As for RT-7, the likelihood of 3 and consequence of 4 from previous quarter is now, at the moment, a likelihood of 2 and consequence of 3 this quarter. It's agreed upon that the cultivation CO<sub>2</sub> risk was be kept open to document the trade-off analysis performed by both cultivation AoA#1 (Growth team) and Environmental team. Since this risk can incur significant cost over-runs in the future and there is heavy reliance on the cultivation system's technology, including need of social acceptance, RMT recommend that the next capstone group who will lead beyond what our group performed should continue the risk management process to continue to recognize collocation opportunities.

(2) **Cultivation/Refinement Risks Open.**

Cultivation/Refinement team completed their assessment and indicated RT-9 could not be downgraded to an appropriate level of likelihood and consequence. This outcome of the cultivation/refinement analysis produced an up-to-date risk level submission, and the status of the risk has been respectively shown as the final risk level, refer to Figure 159.

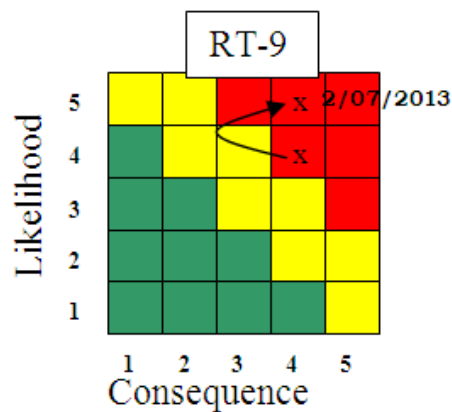

Figure 159. DOD matrix: cultivation/refinement risks open.

During a recent RMT meeting, the received detailed actions performed by cultivation/refinement team were discussed. From the outcome of the meeting and recent email received from cultivation/refinement point of contact, it was determined that additional research and analysis is required to properly solve/mitigate this risk. The agreement between RMT and risk owners (cultivation and refinement teams) was to keep the likelihood and consequence for RT-9 to a high risk level since the decision process for cultivation and refinement system would impose additional demands to Hawaii's power grid.

The RT-9 being likelihood of 4 and consequence of 4 from previous quarter is now, at the moment, a likelihood of 5 and consequence of 4 this quarter. Since this risk can incur significant cost over-runs in the future and there is heavy reliance on availability of electricity in Hawaii, RMT recommend that there is a need for the next capstone group who will lead beyond what our group performed should continue the risk management process to carry on further to mitigate this risk.

*e. Risks Closed*

In the midst of following through RMP to document all received risks and to perform risk management, RMT performed assessment of non-tracked risks to validate if the risks was still a possible constraint/concern for HNAABS project. Each of these risks was analyzed during RMT's meeting to determine integrity of the risk. These non-tracked risks that were just been recently closed will not be deleted from the database to ensure the new capstone group could access RMT's attempt of documenting the characteristics of these non-tracked risks. The full list of non-tracked risks received can be found in Appendix L.

**D. CONCLUSION**

From the risk assessment efforts and attempts to continuous exploratory approach of managing HNAABS risks during our capstone project, there exist undeniable benefits from the captured risk data to make significant contributions to eventually produce a suitable cultivation and refinement systems for HNAABS. The risks recognized that may adversely impact the project are listed in this risk assessment report.

However, since this was the first TRL exploration and biofuel analysis was performed to present an HNAABS concept design solution, including illustration of the projects' estimate costs, RMT recommend for another NPS capstone group to pursue an uninterrupted engineering HNAABS System of Systems research. The documented risks listed in this risk assessment report can be value-added to the next capstone group to continue eliminating and documenting constraints, including managing risks efforts to fully support the improvement of the design and development of a sustainable HNAABS System of Systems.

## APPENDIX G. TRACKED RISKS

The following risk information was collected and recorded in Microsoft Excel format and IAW with the RMP. The accumulated information is updated during RMT briefing to ensure concurrence among peers on tracking/monitoring risks. The raw excel spreadsheet provides a compatible format for entry of the risk specified in this appendix.

### Submission to RMT:

Initiator Refinement Team Date 8/21/2012  
 Risk Type (*Check one*)  Technical  Schedule  Cost

Description of Risk: Hydrocracking power requirement can be expensive

Received Risk: Likelihood # 3 / Consequence # 5

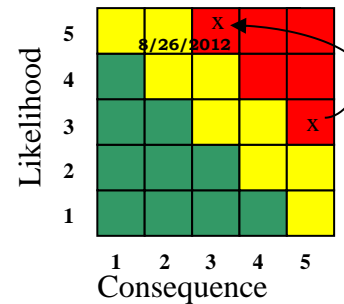

## Risk Review Board Report: RT-1

**Risk Phase**(Check one)

- EMD II
- TECHEVAL
- LRIP
- OPEVAL
- Other \_\_\_\_\_

Disposition Date 8/26/2012

RMT assessed Risk Likelihood # 5 / Consequence # 3  
 Mitigate/Track: assigned RT-1 to track sent Risk to RMT  
 Transfer to \_\_\_\_\_  
 Avoid \_\_\_\_\_

Consequence if Risk is Realized -  Technical  
 Schedule  Cost

**Project Lead:**

- 1<sup>st</sup> Quarter (7/13/2012- 9/11/2012): Mr. Quinn Daniels
- 2<sup>nd</sup> Quarter (9/18/2012-12/11/2012): Mr. John Clark
- 3<sup>rd</sup> Quarter (01/07/2013- 3/28/2013): Mr. Kevin Broadnax

**Final mitigation of Risk: 02/07/ 13**

Re-assessed Risk Likelihood # 3 /Consequence # 3

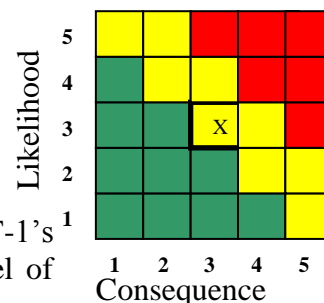

**Final Comment:**

Refinement team completed their assessment and indicates RT-1's mitigation plans have been mitigated to a combined appropriate level of risk likelihood of 3 and consequence of 3.

<b>Risk Tracking</b>	<b>New/Current Title:</b>	<b>Last Update:</b>
<b>No: RT-1</b>	<b>Hydrocracking power requirement can be expensive</b>	2/19/2013
<b>Risk Owner:</b>	<b>RMT:</b>	<b>RMT Lead:</b>
Refinement Team	Req/Risk Team	Edwin Racelis
<b>First Assessment Date:</b> 08/26/2012	<b>Current Assessment Date:</b> 12/09/2012	
<b>Description:</b>	Hydrocracking is the process by which the hydrocarbon molecules are broken into simpler molecules by the addition of hydrogen under high pressure and in the presence of a catalyst. This is a very energy intensive process. The amount of power needed to convert Bio-oil into Bio-fuel can vary significantly depending on the number of hydrocarbons present in the Bio-oil.	
<b>Consequence:</b>	This can increase the costs and time required to convert Bio-Oil into Bio-Fuel therefore reducing the amount of Bio-Fuel being produced.	
<b>Status:</b>	8/21/2012: New Risk. Risk unchanged since RMT is waiting for AoA's completion report. Refer to Capstone IMS to view Risks associated with group	

<b>Risk Tracking No: RT-1</b>	<b>New/Current Title:</b> <b>Hydrocracking power requirement can be expensive</b>	<b>Last Update:</b> 2/19/2013
<p>(Refinement Team)  Received feedback from Prof. Olwell/Sweeney to revise presented Risk's original Title  12/09/2012: Changed the original Title info  02/07/2013: Risk meeting with RMT and received current risk status</p>		
<b>Rationale for Current Assessment:</b> Agreement among peers		
<b>Closure Criteria:</b> Mitigate risk to an appropriate level and receive concurrence among peers		

## Contingency Plan

<b>Description:</b>	If RT-1 is not completed due to scope creep and difficulties in obtaining key data, RMT recommend for the next Capstone Project Team members to utilize RT-1 findings and (if necessary) modify shown mitigation plan to fully determine the potential Cost Risks.
<b>Impact Date:</b>	n/a

## Mitigation Plan: RT-1

<b>Activity No:</b> RT-1_1	<b>Description:</b> Determine Hawaii's power consumption restrictions.	<b>Planned Start Date:</b> 9/18/2012	<b>Actual Start Date:</b> 9/18/2012
<b>Actionee:</b> Refinement Team	<b>Completion Dates:</b>	Original Planned Completion Date: 11/13/2012	Actual Completion Date: 01/23/2013
<b>Status:</b> Closed	<b>Comment:</b> HNAABS refinery will generate its own energy similar to a petroleum crude refinery.		

---

**Activity No:** Description: Planned Start Date: 9/18/2012  
**RT-1\_2** Determine the associated cost with the variations of power consumption. Actual Start Date: 9/18/2012

<b>Action ee:</b>	Refinement and Cost Team	<b>Completion Dates:</b>	Original Planned Completion Date: 11/13/2012 Actual Completion Date: 01/23/2013	<b>Completed</b>
-----------------------	-----------------------------	------------------------------	--	------------------

**Status:** Closed

---

**Comment:** Refinement team developed a power utilization estimate for the cost team that determined power required to refine a barrel of crude oil. A refinery on average only uses 2% of their energy from external electrical sources.

---



---

**Activity No:** Description: Planned Start Date: 9/18/2012  
**RT-1\_3** Determine internal power generation options, (if necessary) need to purchase power, and acquire the required delta to maintain/increase efficiency, and reduce costs. Actual Start Date: 9/18/2012

<b>Actionee:</b>	Refinement Team	<b>Completion Dates:</b>	Original Planned Completion Date: 11/13/2012 Actual Completion Date: 1/23/2013	<b>Completed</b>
------------------	-----------------	------------------------------	---	------------------

**Status:** Closed

---

**Comment:** Internal generation of energy is expected to be up to 60% of our required energy and 32% of our required electricity. Heat Energy from the Waste Management Facility can be captured and utilized in refinement process

---

=====

The following risk information was collected and recorded in Microsoft Excel format and IAW with the RMP. The accumulated information is updated during RMT briefing to ensure concurrence among peers on tracking/monitoring risks. The raw excel spreadsheet provides a compatible format for entry of the risk specified in this appendix.

**Submission to RMT: RT-2**

Initiator Refinement Team Date 8/21/2012

Risk Type (Check one)  Technical  Schedule  Cost

Description of Risk: Non-usable waste byproducts disposal

Received Risk: Likelihood # 3 / Consequence # 3

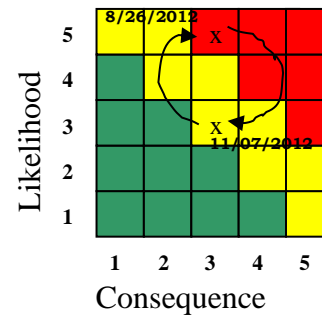

**Risk Review Board Report: RT-2**

Disposition Date 8/26/2012

RMT assessed Risk Likelihood # 5 / Consequence # 3

Mitigate/Track:  assigned RT-2 to track sent Risk to RMT

Transfer to \_\_\_\_\_

Avoid \_\_\_\_\_

Consequence if Risk is Realized -  Technical  Schedule

Cost

**Risk Phase** (Check one)

- EMD II
- TECHEVAL
- LRIP
- OPEVAL
- Other \_\_\_\_\_

**Project Lead:**

1<sup>st</sup> Quarter (7/13/2012- 9/11/2012): Mr. Quinn Daniels  
 2<sup>nd</sup> Quarter (9/18/2012-12/11/2012): Mr. John Clark  
 3<sup>rd</sup> Quarter (01/07/2013- 3/28/2013): Mr. Kevin Broadnax

**Final mitigation of Risk: 2/07/2013**

\_\_\_**Re-assessed Risk Likelihood #\_3\_/Consequence #\_3\_**\_\_\_

**Final Comment:**

Refinement team completed their assessment and indicates RT-2's mitigation plans have been mitigated to a combined appropriate level of risk likelihood of 3 and consequence of 3.

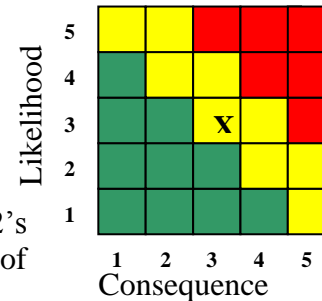

<b>Risk Tracking</b>	<b>New/Current Title:</b>	<b>Last Update:</b>
<b>No: RT-2</b>	<b>Non-usable waste byproducts disposal</b>	12/09/2012
<b>Risk Owner:</b>	<b>RMT:</b>	<b>RMT Lead:</b>
Refinement Team	Req/Risk Team	Edwin Racelis
<b>First Assessment Date:</b> 08/26/2012	<b>Current Assessment Date:</b> 12/09/2012	
<b>Description:</b>	The process of refining Bio-oil into a Bio-fuel generates waste byproducts. Due to Hawaii's strict environmental laws, managing the refinery's waste output levels is necessary.	
<b>Consequence:</b>	If too much waste is produced within the refinery process per environmental regulations, it will require additional costs to be incurred in order to remove the waste from Hawaii. It could also possibly limit the quantity of bio-fuel that can be refined within a given frame due to work stoppage.	

<b>Risk Tracking No: RT-2</b>	<b>New/Current Title:</b> <b>Non-usable waste byproducts disposal</b>	<b>Last Update:</b> 12/09/2012
<b>Status:</b>		
<p>8/21/2012: New Risk.  Risk unchanged since RMT is waiting for AoA's completion report. Refer to Capstone IMS to view Risks associated with group (Refinement Team)  Received feedback from Prof. Olwell/Sweeney to revise presented Risk's original Title  12/09/2012: Changed the original Title info  02/07/2013: Risk meeting with RMT and received current risk status</p>		
<b>Rationale for Current Assessment:</b> Agreement among peers		
<b>Closure Criteria:</b> Mitigate risk to an appropriate level and receive concurrence among peers		

## Contingency Plan

<b>Description:</b>	If RT-2 is not completed due to scope creep and difficulties in obtaining key data, RMT recommend for the next Capstone Project Team members to utilize RT-2 findings and (if necessary) modify shown mitigation plan to fully determine the potential Cost Risks.
<b>Impact Date:</b>	n/a

## Mitigation Plan: RT-2

<b>Activity No:</b> RT-2_1	<b>Description:</b> Identify what waste byproducts are being produced, how much and what to do with them; dispose, recycle and/or collect/store.	<b>Planned Start Date:</b> 9/18/2012 <b>Actual Start Date:</b> 10/15/2012
----------------------------	--	--

<b>Actionee:</b>	Refinement Team	<b>Completion Dates:</b>	Original Planned Completion Date: 11/05/2012 Actual Completion Date: 01/23/2013	<b>Completed</b>
------------------	-----------------	--------------------------	--	------------------

**Status:** Closed

**Comment:** Data collected and submitted in report. Waste product data of a refinery has been collected and documented in the final report.

**Activity No: Description:** RT-2\_2 Define allowable waste output. Planned Start Date: 9/18/2012  
Actual Start Date: 10/15/2012

<b>Actionee:</b>	Refinement and Environmental Team	<b>Completion Dates:</b>	Original Planned Completion Date: 11/05/2012 Actual Completion Date: 01/23/2013	<b>Completed</b>
------------------	-----------------------------------	--------------------------	--	------------------

**Status:** Closed

**Comment:** Worked with the Environmental Team. The refinery must abide by Resource Conservation & Recovery Act, Clean Water Act, and Clean Air Act. All information was submitted with final report and risk assessment.

**Activity No: Description:** RT-2\_3 Define environmental and health regulations regarding waste. Planned Start Date: 9/18/2012  
Actual Start Date: 10/15/2012

<b>Actionee:</b>	Refinement Team	<b>Completion Dates:</b>	Original Planned Completion Date: 11/13/2012 Actual Completion Date: 01/23/2013	<b>Completed</b>
------------------	-----------------	--------------------------	--	------------------

**Status:** Closed

**Comment:** Worked with the Environmental Team. All regulatory information has been addressed in the final report.

**Activity No: Description:** RT-2\_4 Research existing refineries waste by-product outputs. Research possibly shipping waste out of Hawaii. Planned Start Date: 9/18/2012  
Actual Start Date: 10/15/12

<b>Actionee:</b>	Refinement Team	<b>Completion Dates:</b>	Original Planned Completion Date: 10/23/2012 Actual Completion Date: 01/23/2013	<b>Completed</b>
------------------	-----------------	--------------------------	--	------------------

**Status:** Closed

**Comment:** Waste products of the refinery will be documented in the final report.

=====

The following risk information was collected and recorded in Microsoft Excel format and IAW with the RMP. The accumulated information is updated during RMT briefing to ensure concurrence among peers on tracking/monitoring risks. The raw excel spreadsheet provides a compatible format for entry of the risk specified in this appendix.

**Submission to RMT:**

Initiator Refinement Team Date 8/21/2012

Risk Type (Check one)  Technical  Schedule  Cost

Description of Risk: If an existing refinery cannot be converted to meet KPPs, then a new refinery may need to be built.

Received Risk: Likelihood # 3 / Consequence # 4

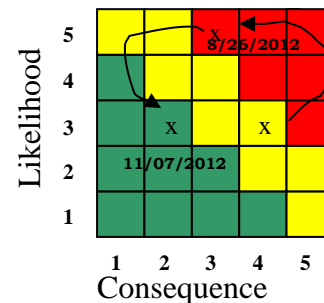

## Risk Review Board Report: RT-3

**Risk Phase**(*Check one*)

- EMD II
- TECHEVAL
- LRIP
- OPEVAL
- Other \_\_\_\_\_

Disposition Date 11/07/2012\_\_\_\_\_

RMT assessed Risk Likelihood # 3 / Consequence # 2

Mitigate/Track: assigned RT-3 on 08/26/12 to track sent

Risk to RMT

Transfer to \_\_\_\_\_

Avoid \_\_\_\_\_

Consequence if Risk is Realized -  Technical

Schedule  Cost

### Project Lead:

1<sup>st</sup> Quarter (7/13/2012- 9/11/2012): Mr. Quinn Daniels

2<sup>nd</sup> Quarter (9/18/2012-12/11/2012): Mr. John Clark

3<sup>rd</sup> Quarter (01/07/2013- 3/28/2013): Mr. Kevin Broadnax

**Final mitigation of Risk: 02/07/2013**

\_\_\_Re-assessed Risk Likelihood # 3\_\_\_/Consequence # 2\_\_\_

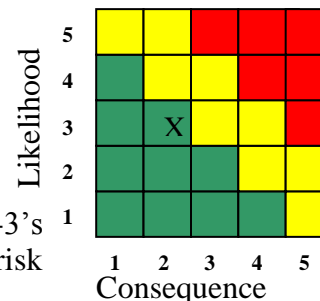

**Final Comment:**

Refinement team completed their assessment and indicates RT-3's mitigation plans have been mitigated to a combined appropriate level of risk likelihood of 3 and consequence of 2.

<b>Risk Tracking</b>	<b>New/Current Title:</b>	<b>Last Update:</b>
<b>No: RT-3</b>	<b>If an existing refinery cannot be converted to meet KPPs, then a new refinery may need to be built.</b>	08/26/2012
<b>Risk Owner:</b>	<b>RMT:</b>	<b>RMT Lead:</b>
Refinement Team	Req/Risk Team	Edwin Racelis
<b>First Assessment Date:</b> 08/26/2012	<b>Current Assessment Date:</b> 12/09/2012	
<b>Description:</b>	Converting an existing oil refinery to produce bio-fuel and meet KPPs may be difficult due to the limited number and size of existing refineries in Hawaii.	
<b>Consequence:</b>	If an existing refinery cannot be converted, a new refinery will need to be built. If the appropriate permits cannot be obtained to build a new refinery, KPPs may not be met. This would potentially delay the schedule, increase the cost and reduce the feasibility of meeting KPPs.	
<b>Status:</b>	8/21/2012: New Risk.	

<b>Risk Tracking</b> <b>No: RT-3</b>	<b>New/Current Title:</b> <b>If an existing refinery cannot be converted to meet KPPs, then a new refinery may need to be built.</b>	<b>Last Update:</b> 08/26/2012
<p>Risk unchanged since RMT is waiting for AoA's completion report. Refer to Capstone IMS to view Risks associated with group (Refinement Team) 02/07/2013: Risk meeting with RMT and received current risk status</p>		
<p><b>Rationale for Current Assessment:</b> Agreement among peers</p>		
<p><b>Closure Criteria:</b> Mitigate risk to an appropriate level and receive concurrence among peers</p>		

## Contingency Plan

<b>Description:</b>	If RT-3 is not completed due to scope creep and difficulties in obtaining key data, RMT recommend for the next Capstone Project Team members to utilize RT-3 findings and (if necessary) modify shown mitigation plan to fully determine the potential Technical, Schedule, and Cost Risks.
<b>Impact Date:</b>	n/a

## Mitigation Plan: RT-3

<b>Activity No:</b> <b>RT-3_1</b>	<b>Description:</b> <b>Determine what refineries exist in Hawaii</b>	<b>Planned Start Date:</b> 08/06/2012 <b>Actual Start Date:</b> 08/06/2012
<b>Actionee:</b> Environmental Team	<b>Completion Dates:</b> Original Planned Completion Date: 08/06/2012 Actual Completion Date: 08/06/2012	<b>Completed</b>

---

Status: Closed

---

Comment: Existing Refineries have been studied with Tesoro remaining as a potential site.

---

**Activity No:** **Description:** **Determine existing refineries size, fuel/bio/fuel output, bio-oil being refined, etc.** Planned Start Date: 9/18/2012  
**RT-3\_2** Actual Start Date: 10/02/2012

Actionee: Refinement Team	Completion Dates:	Original Planned Completion Date: 11/05/2012 Actual Completion Date: 10/26/2012	Completed
---------------------------	-------------------	--	-----------

Status: Closed

---

Comment: Status update indicates Refinement team has the appropriate "Data Collected."

---

**Activity No:** **Description:** **Research conversion requirements and identify potential issues.** Planned Start Date: 9/03/2012  
**RT-3\_3** Actual Start Date: 9/24/2012

Actionee: Refinement Team	Completion Dates:	Original Planned Completion Date: 11/13/2012 Actual Completion Date: 01/16/2013	Completed
---------------------------	-------------------	--	-----------

Status: Closed

---

Comment: Conversion requirements have been determined, and some issues have been identified (Honeywell Report would give detail). Issues have been identified. All are documented in the final report

---

**Activity No:** **Description:** **Perform trade-off analysis of existing refineries versus building a new refinery** Planned Start Date: 9/03/2012  
**RT-3\_4** Actual Start Date: 10/02/2012

Actionee: Refinement Team	Completion Dates:	Original Planned Completion Date: 11/13/2012 Actual Completion Date: -01/23/2013	Completed
---------------------------	-------------------	---	-----------

Status: Closed

---

Comment: Final report discusses pros/cons with building new or retrofitting an existing

---

---

refinery.

---

**Activity No:** **Description: Define TRL of bio refinery**  
**RT-3\_5**

Planned Start Date: 9/18/2012  
Actual Start Date: 10/02/2012

<b>Actionee:</b> Refinement Team	<b>Completion Dates:</b> Original Planned Completion Date: 10/23/2012 Actual Completion Date: 10/26/2012	<b>Completed</b>
----------------------------------	---	------------------

**Status:** Closed

---

**Comment:** The operation of the bio-refinery in Geismar, LA has the TRL of 8.

---

=====

The following risk information was collected and recorded in Microsoft Excel format and IAW with the RMP. The accumulated information is updated during RMT briefing to ensure concurrence among peers on tracking/monitoring risks. The raw excel spreadsheet provides a compatible format for entry of the risk specified in this appendix.

**Submission to RMT:**

Initiator Cost Team Date 8/25/2012  
 Risk Type (Check one)  Technical  Schedule  Cost

Description of Risk: Capital cost for new refinery not profitable enough for public interest

Received Risk: Likelihood # 2 / Consequence # 4

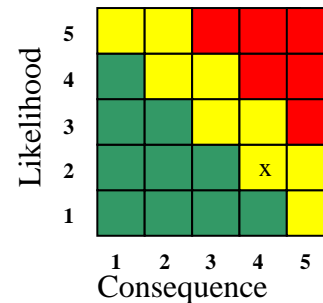

## Risk Review Board Report: RT-4

### Risk Phase *(Check one)*

- EMD II
- TECHEVAL
- LRIP
- OPEVAL
- Other \_\_\_\_\_

Disposition Date 08/26/2012\_\_\_\_\_

RMT assessed Risk Likelihood # 2 /Consequence # 4  
 Mitigate/Track: assigned RT-4 to track sent Risk to RMT  
 Transfer to \_\_\_\_\_  
 Avoid \_\_\_\_\_

Consequence if Risk is Realized -  Technical  Schedule  
 Cost

### Project Lead:

- 1<sup>st</sup> Quarter (7/13/2012- 9/11/2012): Mr. Quinn Daniels
- 2<sup>nd</sup> Quarter (9/18/2012-12/11/2012): Mr. John Clark
- 3<sup>rd</sup> Quarter (01/07/2013- 3/28/2013): Mr. Kevin Broadnax

**Final mitigation of Risk: 02/07/2013**

\_\_\_**Re-assessed Risk Likelihood #** 2 **/Consequence #** 2\_\_\_

**Final Comment:**

Cost team completed their assessment and indicates RT-4 can be downgraded to an appropriate level of risk likelihood of 2 and consequence of 2. Current recommendation hybrid/retrofit option and govt. collaborate with corporate entity in Hawaii, Thus, no need to purchase/build new facilities.

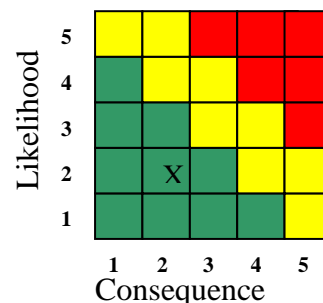

<b>Risk Tracking</b>	<b>New/Current Title:</b>	<b>Last Update:</b>
<b>No: RT-4</b>	<b>Capital cost for new refinery not profitable enough for public interest</b>	12/09/2012
<b>Risk Owner:</b>	<b>RMT:</b>	<b>RMT Lead:</b>
Cost Team	Req/Risk Team	Edwin Racelis
<b>First Assessment Date:</b> 08/26/2012	<b>Current Assessment Date:</b> 12/09/2012	
<b>Description:</b>	Within the scope of the Biofuels feasibility study, the cultivation and refinement processes will require specific facilities to achieve their required outputs. A major assumption would be to leverage current production and refinement facilities on the islands to produce our Biofuels mix. However, the lack/inadequacy of current facilities could drive the need for MILCON funding requirements to build new facilities or considerably modify current facilities.	
<b>Consequence:</b>	If MILCON funding is needed, specific requirements must be defined and the DoD budgetary process must begin. Congressional approval of requirements can drive schedule before construction could begin, thusly pushing out schedule and delivering a serious blow to	

<b>Risk Tracking</b>	<b>New/Current Title:</b>	<b>Last Update:</b>
<b>No: RT-4</b>	<b>Capital cost for new refinery not profitable enough for public interest</b>	12/09/2012
feasibility.		

**Status:**

8/25/2012: New Risk.  
 Risk unchanged since RMT is waiting for AoA's completion report and/or Cost team's cost analysis. Refer to Capstone IMS to view Risks associated with group (Cost Team)  
 02/07/2013: Risk meeting with RMT and received current risk status

**Rationale for Current Agreement among peers**

**Assessment:**

**Closure Criteria:** Mitigate risk to an appropriate level and receive concurrence among peers

## Contingency Plan

<b>Description:</b>	If RT-4 is not completed due to scope creep and difficulties in obtaining key data, RMT recommend for the next Capstone Project Team members to utilize RT-4current findings and (if necessary) modify shown mitigation plan to fully determine the potential Cost Risks.
<b>Impact Date:</b>	n/a

## Mitigation Plan: RT-4

**Activity No: Description:** Assess current Hawaii facilities landscape early    **Planned Start Date:** 12/12/2012

---

**RT-4\_1**

Actual Start Date: 12/12/2012

<b>Actionee:</b> Cost Team	<b>Completion Dates:</b> Original Planned Completion Date: 02/12/2013 Actual Completion Date: 02/07/2013	<b>Completed</b>
----------------------------	---	------------------

**Status:** Closed

---

**Comment:** Analysis has been performed – i.e., hybrid/retrofit is the current recommendation, govt. will partnership with corporate entity in Hawaii, and documented in the final report. Furthermore, no purchase/build of new facilities required.

---

=====

The following risk information was collected and recorded in Microsoft Excel format and IAW with the RMP. The accumulated information is updated during RMT briefing to ensure concurrence among peers on tracking/monitoring risks. The raw excel spreadsheet provides a compatible format for entry of the risk specified in this appendix.

**Submission to RMT:**

**Initiator** Cultivation Team **Date** 8/25/2012

**Risk Type** (*Check one*) Technical  Schedule  Cost

**Description of Risk:** Cultivation Technical Maturity Risk

**Received Risk: Likelihood #** 3 **/Consequence #** 5

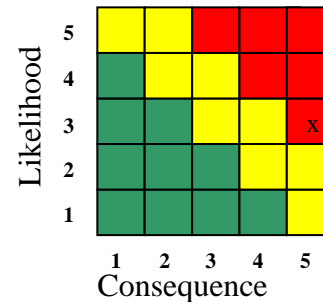

## Risk Review Board Report: RT-5

**Risk Phase**(*Check one*)

- EMD II
- TECHEVAL
- LRIP
- OPEVAL
- Other

Disposition Date 08/26/2012

RMT assessed Risk Likelihood # 3 /Consequence # 5  
 Mitigate/Track: assigned RT-5 to track sent Risk to RMT  
 Transfer to \_\_\_\_\_  
 Avoid \_\_\_\_\_

Consequence if Risk is Realized -  Technical  Schedule  
 Cost

### Project Lead:

- 1<sup>st</sup> Quarter (7/13/2012- 9/11/2012): Mr. Quinn Daniels
- 2<sup>nd</sup> Quarter (9/18/2012-12/11/2012): Mr. John Clark
- 3<sup>rd</sup> Quarter (01/07/2013- 3/28/2013): Mr. Kevin Broadnax

**Final mitigation of Risk: 02/07/2013**

**Re-assessed Risk Likelihood # 1 /Consequence # 4**

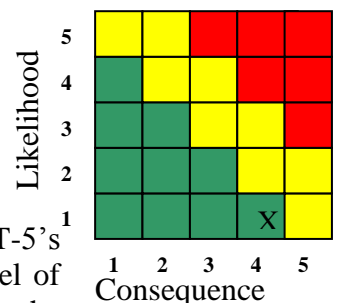

**Final Comment:**

Cultivation team completed their assessment and indicates RT-5's mitigation plans have been mitigated to a combined appropriate level of risk likelihood of 1 and consequence of 4. However, there is a need for the next capstone group who will lead beyond what our group performed should continue to monitor this risk since there is a heavy reliance on availability of technology that can cause a significant risk cost over-runs.

<b>Risk Tracking No: RT-5</b>	<b>New/Current Title: Cultivation Technical Maturity Risk</b>	<b>Last Update: 08/26/2012</b>
<b>Risk Owner: Cultivation Team</b>	<b>RMT: Req/Risk Team</b>	<b>RMT Lead: Edwin Racelis</b>
<b>First Assessment Date: 08/26/2012</b>	<b>Current Assessment Date: 12/09/2012</b>	
<b>Description:</b>	Technical maturity of cultivation methods not currently at suitable levels to support large scale industrial operations.	
<b>Consequence:</b>	Could result in negative power output or insufficient growth rates.	

<b>Status:</b>	<p>8/25/2012: New Risk.                  Risk unchanged since RMT is waiting for AoA's completion report. Refer to Capstone IMS to view Risks associated with group (Cultivation Team)                  02/07/2013: Risk meeting with RMT and received current risk status</p>
----------------	--

<b>Risk Tracking</b> <b>No: RT-5</b>	<b>New/Current Title:</b> <b>Cultivation Technical Maturity Risk</b>	<b>Last Update:</b> 08/26/2012
<b>Rationale for Current Assessment:</b> Agreement among peers		
<b>Closure Criteria:</b> Mitigate risk to an appropriate level and receive concurrence among peers		

## Contingency Plan

<b>Description:</b>	If RT-5 is not completed due to scope creep and difficulties in obtaining key data, RMT recommend for the next Capstone Project Team members to utilize RT-5current findings and (if necessary) modify shown mitigation plan to fully determine the potential Technical, Schedule, and Cost Risks.
<b>Impact Date:</b>	n/a

## Mitigation Plan: RT-5

<b>Activity No:</b> RT-5_1	<b>Description:</b> Determine scalability of major current laboratory methods for sustainability in a large scale production environment.	Planned Start Date: 10/02/2012	Actual Start Date: 10/02/2012
<b>Actionee:</b>	Cultivation Team	<b>Completion Dates:</b>	Original Planned Completion Date: 01/18/2013 Actual Completion Date: 02/08/2013
<b>Status:</b>	Closed		
<b>Comment:</b>	Choosing PBR (vice OMEGA), microfiltration, flash drying and quantum fracturing were chosen after completing the AoAs and documented in the final report. At this moment, a cultivation system has been determined		

---

through the tasks performed during the AoAs. The next research to perform would be to document the recommended cultivation system can meet the sustainability in a large scale production environment through continuing the research efforts, use our groups risk findings, by the next upcoming capstone group to further refine the TRL level going forward.

---

**Activity No:** **Description: Define TRL of cultivation** Planned Start Date: 10/02/2012  
**RT-5\_2** Actual Start Date: 10/02/2012

<b>Actionee:</b>	Refinement Team	<b>Completion Dates:</b>	Original Planned Completion Date: 01/18/2013 Actual Completion Date: 02/08/2013	<b>Completed</b>
------------------	-----------------	--------------------------	--	------------------

**Status:** Closed

---

**Comment:** Choosing PBR (vice OMEGA), microfiltration, flash drying and quantum fracturing were chosen after completing the AoA's and documented in the final report. At this moment, a cultivation system has been determined through the tasks performed during the AOAs; however, since this is the first cultivation system concept solution, the next capstone group will need to continue the ongoing effort to authenticate the TRL level and update the current projected estimate costs as shown from the HNAABs final report.

---

=====

The following risk information was collected and recorded in Microsoft Excel format and IAW with the RMP. The accumulated information is updated during RMT briefing to ensure concurrence among peers on tracking/monitoring risks. The raw excel spreadsheet provides a compatible format for entry of the risk specified in this appendix.

**Submission to RMT:**

**Initiator** Cultivation Team **Date** 8/25/2012

**Risk Type** (*Check one*) Technical Schedule  Cost

**Description of Risk:** Cultivation Land Resource Risk

**Received Risk: Likelihood #** 3 **/Consequence #** 4

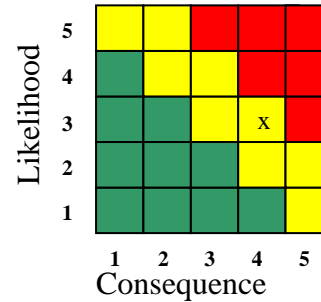

## Risk Review Board Report: RT-6

**Risk Phase**(*Check one*)

- EMD II
- TECHEVAL
- LRIP
- OPEVAL
- Other

Disposition Date 08/26/2012

RMT assessed Risk Likelihood # 3 / Consequence # 4  
 Mitigate/Track:  assigned RT-6 to track sent Risk to RMT   
 Transfer to \_\_\_\_\_  
 Avoid \_\_\_\_\_

Consequence if Risk is Realized -  Technical  Schedule  
 Cost

### Project Lead:

- 1<sup>st</sup> Quarter (7/13/2012- 9/11/2012): Mr. Quinn Daniels
- 2<sup>nd</sup> Quarter (9/18/2012-12/11/2012): Mr. John Clark
- 3<sup>rd</sup> Quarter (01/07/2013- 3/28/2013): Mr. Kevin Broadnax

**Final mitigation of Risk: 02/07/2013**

\_\_\_**Re-assessed Risk Likelihood #** 1 **/Consequence #** 3 \_\_\_

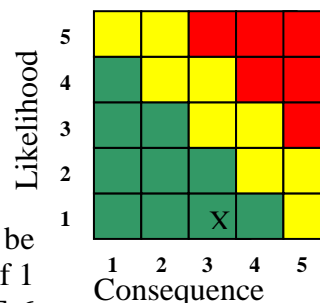

**Final Comment:**

Cultivation team completed their assessment and indicates RT-6 can be downgraded to an appropriate level of risk likelihood of risk likelihood of 1 and consequence of 3. The next capstone team will require reviewing RT-6 findings and need to double check with land estimate and available land, including identify social acceptance.

<b>Risk Tracking</b>	<b>New/Current Title:</b>	<b>Last Update:</b>
<b>No: RT-6</b>	<b>Cultivation Land Resource Risk</b>	08/26/2012
<b>Risk Owner:</b>	<b>RMT:</b>	<b>RMT Lead:</b>
Cultivation Team	Req/Risk Team	Edwin Racelis
<b>First Assessment Date:</b> 08/26/2012	<b>Current Assessment Date:</b> 12/09/2012	
<b>Description:</b>	Land use requirements may be unsustainable for Hawaiian islands environment due to geography, usable land already populated, or various political, legal, and socio-economical reasons. Available land may be too sparse and separated to be industrially viable.	
<b>Consequence:</b>	Insufficient algae bio oil production.	

<b>Status:</b>	8/25/2012: New Risk. Risk unchanged since RMT is waiting for AoA's completion report. Refer to Capstone IMS to view Risks associated with group (Cultivation Team)
----------------	---

<b>Risk Tracking No: RT-6</b>	<b>New/Current Title: Cultivation Land Resource Risk</b>	<b>Last Update: 08/26/2012</b>
02/07/2013: Risk meeting with RMT and received current risk status		
<b>Rationale for Current Assessment:</b> Agreement among peers		
<b>Closure Criteria:</b> Mitigate risk to an appropriate level and receive concurrence among peers		

## Contingency Plan

<b>Description:</b>	If RT-6 is not completed due to scope creep and difficulties in obtaining key data, RMT recommend for the next Capstone Project Team members to utilize RT-6current findings and (if necessary) modify shown mitigation plan to fully determine the potential Technical, Schedule, and Cost Risks.
<b>Impact Date:</b>	n/a

## Mitigation Plan: RT-6

<b>Activity No: RT-6_1</b>	<b>Description: Identify land available and make trade-off where necessary (non-ideal sloping, sunlight, resource, distance, etc..)</b>	<b>Planned Start Date:</b> 10/02/2012	<b>Actual Start Date:</b> 10/02/2012
<b>Actionee:</b> Cultivation Team	<b>Completion Dates:</b> Original Planned Completion Date: 01/18/2013 Actual Completion Date: 02/08/2013	<b>Require re-check of findings</b>	
<b>Status:</b> Open			
<b>Comment:</b> Chosen PBR as our growth technology and documented in the final report;			

---

however, the next capstone team will require reviewing RT-6 findings and need to double check with land estimate and available land, including social acceptance.

---

=====

The following risk information was collected and recorded in Microsoft Excel format and IAW with the RMP. The accumulated information is updated during RMT briefing to ensure concurrence among peers on tracking/monitoring risks. The raw excel spreadsheet provides a compatible format for entry of the risk specified in this appendix.

**Submission to RMT:**

**Initiator** \_\_Cultivation Team\_\_ **Date** \_\_8/25/2012\_\_  
**Risk Type** (*Check one*)\_\_\_Technical \_\_\_Schedule \_\_X\_\_ Cost

**Description of Risk:** \_Cultivation CO2 Risk \_\_\_\_\_

**Received Risk: Likelihood #**\_3\_\_\_/**Consequence #** \_4\_\_

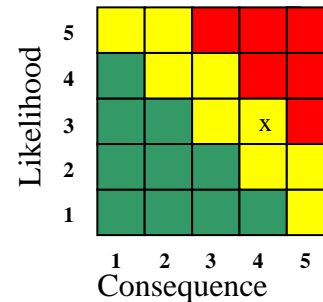

## Risk Review Board Report: RT-7

**Risk Phase**(*Check one*)

- EMD II
- TECHEVAL
- LRIP
- OPEVAL
- Other

Disposition Date 08/26/2012

RMT assessed Risk Likelihood # 3 / Consequence # 4  
 Mitigate/Track: assigned RT-7 to track sent Risk to RMT  
 Transfer to \_\_\_\_\_  
 Avoid \_\_\_\_\_

Consequence if Risk is Realized -  Technical  Schedule  
 Cost

### Project Lead:

- 1<sup>st</sup> Quarter (7/13/2012- 9/11/2012): Mr. Quinn Daniels
- 2<sup>nd</sup> Quarter (9/18/2012-12/11/2012): Mr. John Clark
- 3<sup>rd</sup> Quarter (01/07/2013- 3/28/2013): Mr. Kevin Broadnax

**Final mitigation of Risk: 02/07/2013**

\_\_\_**Re-assessed Risk Likelihood #** 2 \_\_\_/**Consequence #** 3 \_\_\_

**Final Comment:**

Cultivation team completed their assessment and indicates RT-7 can be downgraded to an appropriate level of risk likelihood of 2 and consequence of 3. However, the next capstone team will require reviewing RT-7 and need to double check findings, including identify social acceptance.

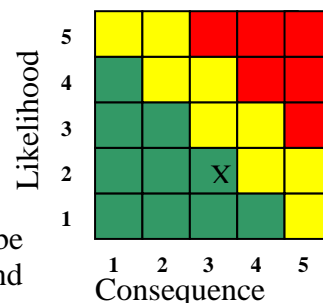

<b>Risk Tracking</b>	<b>New/Current Title:</b>	<b>Last Update:</b>
<b>No: RT-7</b>	<b>Cultivation CO2 Risk</b>	08/26/2012
<b>Risk Owner:</b>	<b>RMT:</b>	<b>RMT Lead:</b>
Cultivation Team	Req/Risk Team	Edwin Racelis
<b>First Assessment Date:</b> 08/26/2012	<b>Current Assessment Date:</b> 12/09/2012	
<b>Description:</b>	Land use requirements may be unsustainable for Hawaiian islands environment due to geography, usable land already populated, or various political, legal, and socio-economical reasons. Available land may be too sparse and separated to be industrially viable.	
<b>Consequence:</b>	Insufficient algae bio oil production.	

<b>Status:</b>	<p>8/25/2012: New Risk.                  Risk unchanged since RMT is waiting for AoA's completion report. Refer to Capstone IMS to view Risks associated with group (Cultivation Team)                  02/07/2013: Risk meeting with RMT and received current risk status</p>
----------------	--

<b>Risk Tracking</b> <b>No: RT-7</b>	<b>New/Current Title:</b> <b>Cultivation CO2 Risk</b>	<b>Last Update:</b> 08/26/2012
<b>Rationale for Current Assessment:</b> Agreement among peers		
<b>Closure Criteria:</b> Mitigate risk to an appropriate level and receive concurrence among peers		

## Contingency Plan

<b>Description:</b>	If RT-7 is not completed due to scope creep and difficulties in obtaining key data, RMT recommend for the next Capstone Project Team members to utilize RT-7 current findings and (if necessary) modify shown mitigation plan to fully determine the potential Technical, Schedule, and Cost Risks.
<b>Impact Date:</b>	n/a

## Mitigation Plan: RT-7

<b>Activity No:</b> RT-7_1	<b>Description:</b> Perform trade-off analysis of methods and land available to optimize CO2 usage from all available resources that are ideal for various cultivation methods.	Planned Start Date: 10/02/2012	Actual Start Date: 10/02/2012
<b>Actionee:</b>	Cultivation Team	<b>Completion Dates:</b>	Original Planned Completion Date: 01/18/2013 Actual Completion Date: 02/08/2013 <b>Require re-check of findings</b>
<b>Status:</b>	Open		
<b>Comment:</b>	Chosen PBR as our growth technology and documented in the final report; however, the next capstone team will require reviewing RT-7 and need to double check findings, including social acceptance.		

=====

The following risk information was collected and recorded in Microsoft Excel format and IAW with the RMP. The accumulated information is updated during RMT briefing to ensure concurrence among peers on tracking/monitoring risks. The raw excel spreadsheet provides a compatible format for entry of the risk specified in this appendix.

**Submission to RMT:**

**Initiator** Environmental Team **Date** 8/25/2012  
**Risk Type** (*Check one*)  **Technical**  **Schedule**  **Cost**

**Description of Risk:** Invasive Algae species

**Received Risk: Likelihood #** 2 **/Consequence #** 4

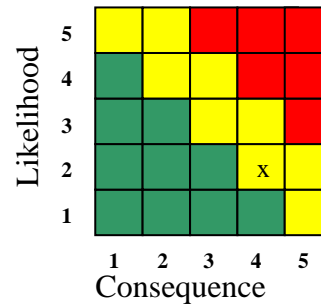

## Risk Review Board Report: RT-8

Disposition Date 08/26/2012

RMT assessed Risk Likelihood # 2 / Consequence # 4  
 Mitigate/Track: assigned RT-8 to track sent Risk to RMT  
 Transfer to \_\_\_\_\_  
 Avoid \_\_\_\_\_

Consequence if Risk is Realized -  Technical  Schedule  
 Cost

### Project Lead:

- 1<sup>st</sup> Quarter (7/13/2012- 9/11/2012): Mr. Quinn Daniels
- 2<sup>nd</sup> Quarter (9/18/2012-12/11/2012): Mr. John Clark
- 3<sup>rd</sup> Quarter (01/07/2013- 3/28/2013): Mr. Kevin Broadnax

**Risk Phase**(*Check one*)

- EMD II
- TECHEVAL
- LRIP
- OPEVAL
- Other \_\_\_\_\_

**Final mitigation of Risk: 02/07/2013**

\_\_\_Re-assessed Risk Likelihood # 1\_\_\_/Consequence # 4\_\_\_

**Final Comment:**

Cultivation/Environment team completed their assessment and indicates RT-8's mitigation plan has been mitigated to a combined appropriate level of risk likelihood of 1 and consequence of 4.

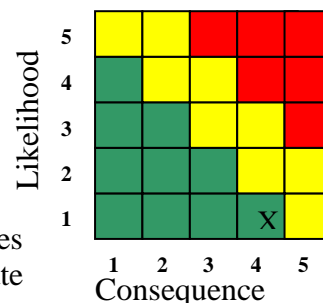

<b>Risk Tracking</b>	<b>New/Current Title:</b>	<b>Last Update:</b>
<b>No: RT-8</b>	<b>Invasive Algae species</b>	08/26/2012
<b>Risk Owner:</b>	<b>RMT:</b>	<b>RMT Lead:</b>
Environmental/Cultivation Team	Req/Risk Team	Edwin Racelis
<b>First Assessment Date:</b> 08/26/2012	<b>Current Assessment Date:</b> 12/09/2012	
<b>Description:</b>	The cultivation site using an open pond system could cause invasive algae to get into the ecosystem.	
<b>Consequence:</b>	The invasive algae can take over the local algae in areas around the cultivation site in Hawaii.	

**Status:**

8/25/2012: New Risk.  
 Risk unchanged since RMT is waiting for AoA's completion report.  
 Refer to Capstone IMS to view Risks associated with group  
 (Cultivation and Environmental Team)  
 02/07/2013: Risk meeting with RMT and received current risk status

<b>Risk Tracking</b> <b>No: RT-8</b>	<b>New/Current Title:</b> <b>Invasive Algae species</b>	<b>Last Update:</b> 08/26/2012
<b>Rationale for Current Agreement among peers</b>		
<b>Assessment:</b>		
<b>Closure Criteria:</b> Mitigate risk to an appropriate level and receive concurrence among peers		

## Contingency Plan

<b>Description:</b>	If RT-8 is not completed due to scope creep and difficulties in obtaining key data, RMT recommend for the next Capstone Project Team members to utilize RT-8current findings and (if necessary) modify shown mitigation plan to fully determine the potential Technical, Schedule, and Cost Risks.
<b>Impact Date:</b>	n/a

## Mitigation Plan: RT-8

<b>Activity No:</b> <b>RT-8_1</b>	<b>Description:</b> Use Closed systems (Bio-reactor).	<b>Planned Start Date:</b> 11/06/2012	<b>Actual Start Date:</b> 11/06/2012
<b>Actionee:</b>	Cultivation/Environmental Team	<b>Completion Dates:</b>	Original Planned Completion Date: 11/06/2012 Actual Completion Date: 11/06/2012
<b>Status:</b>	Closed		
<b>Comment:</b>	Mitigate by only using algae species not on the banned algae list and use of PBR (closed system).		

<b>Activity No:</b> <b>RT-8_2</b>	<b>Description:</b> Test/Inspect algae species in pond (if used).	<b>Planned Start Date:</b> 11/06/2012	<b>Actual Start Date:</b> 11/06/2012
<b>Actionee:</b>	Refinement Team	<b>Completion</b>	Original Planned Completion Date: 11/06/2012 Actual Completion Date: 11/06/2012
			<b>Completed</b>

	Dates:	
--	--------	--

Status: Closed

---

Comment: Mitigate by only using algae species not on the banned algae list and use of PBR (closed system).

---

=====

The following risk information was collected and recorded in Microsoft Excel format and IAW with the RMP. The accumulated information is updated during RMT briefing to ensure concurrence among peers on tracking/monitoring risks. The raw excel spreadsheet provides a compatible format for entry of the risk specified in this appendix.

**Submission to RMT:**

**Initiator** Requirement Team **Date** 8/21/2012  
**Risk Type** (*Check one*) Technical Schedule  Cost

**Description of Risk:** Sufficient overhead in Hawaii Electrical Infrastructure

**Received Risk: Likelihood #** 4 **/Consequence #** 4

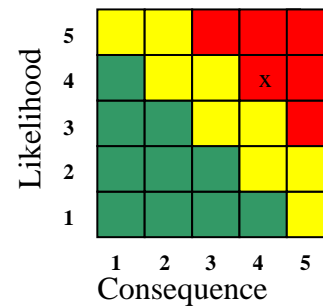

## Risk Review Board Report: RT-9

Disposition Date 11/07/2012

RMT assessed Risk Likelihood # 4 / Consequence # 4  
 Mitigate/Track: assigned RT-9 to track sent Risk to RMT  
 Transfer to \_\_\_\_\_  
 Avoid \_\_\_\_\_

Consequence if Risk is Realized -  Technical  Schedule  
 Cost

### Project Lead:

- 1<sup>st</sup> Quarter (7/13/2012- 9/11/2012): Mr. Quinn Daniels
- 2<sup>nd</sup> Quarter (9/18/2012-12/11/2012): Mr. John Clark
- 3<sup>rd</sup> Quarter (01/07/2013- 3/28/2013): Mr. Kevin Broadnax

**Risk Phase**(*Check one*)

- EMD II
- TECHEVAL
- LRIP
- OPEVAL
- Other \_\_\_\_\_

**Final mitigation of Risk: 02/07/2013**

**Re-assessed Risk Likelihood # 5 /Consequence # 4**

**Final Comment:**

Cultivation/Refinement team completed their assessment and indicates RT-9 require further analysis and recommended the combined appropriate level of risk likelihood of 5 and consequence of 4. However, the next capstone team requires carrying on the engineering research to lower the risk level of this risk submission and continue to mitigate RT-9.

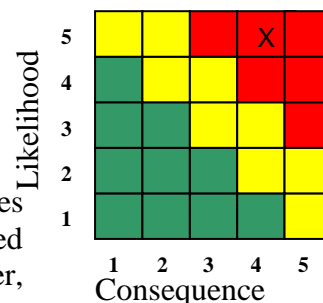

<b>Risk Tracking</b>	<b>New/Current Title:</b>	<b>Last Update:</b>
<b>No: RT-9</b>	<b>Sufficient overhead in Hawaii Electrical Infrastructure</b>	11/07/2012
<b>Risk Owner:</b>	<b>RMT:</b>	<b>RMT Lead:</b>
Refinement/ Cultivation Team	Req/Risk Team	Edwin Racelis
<b>First Assessment Date:</b> 08/26/2012	<b>Current Assessment Date:</b> 12/09/2012	
<b>Description:</b>	Hawaii has the highest electricity costs in the nation. It also consumes slightly more electricity than it produces in-state. Hawaii's Net Trade Index (ratio) is 0.98, its Net Interstate Trade of -282 million KWh and its Average Retail Price in 2010 for all sectors is 25.12 cents per KWh. Based on this info, Hawaii is actually using slightly more electricity than it can produce in-state. Any additional electricity demands stemming from new or upgraded infrastructures to support HNAABS would force Hawaii to procure extra electricity from somewhere else, or increase its grid capacity to accommodate the extra usage.	
<b>Consequence:</b>	Electricity costs in Hawaii may increase, which may result in	

<b>Risk Tracking No: RT-9</b>	<b>New/Current Title: Sufficient overhead in Hawaii Electrical Infrastructure</b>	<b>Last Update: 11/07/2012</b>
-----------------------------------	---	------------------------------------

HNAABS not meeting its \$3 target for Free On-Board cost of biofuel. Hawaii's power grid may be subjected to overloads, resulting in power interruptions in the state. Addressing the lack of sufficient grid capacity may delay or impact HNAABS program schedules. Adding power-related infrastructures may cause significant environmental concerns and additional costs to HNAABS.

**Status:**

8/21/2012: New Risk.  
Risk unchanged since RMT is waiting for AoA's completion report. Refer to Capstone IMS to view Risks associated with group (Cultivation and Refinement Team)  
02/07/2013: Risk meeting with RMT and received current risk status

**Rationale for Current Assessment:** Agreement among peers

**Closure Criteria:** Mitigate risk to an appropriate level and receive concurrence among peers

## Contingency Plan

<b>Description:</b>	If RT-9 is not completed due to scope creep and difficulties in obtaining key data, RMT recommend for the next Capstone Project Team members to utilize RT-9current findings and (if necessary) modify shown mitigation plan to fully determine the potential Technical, Schedule, and Cost Risks.
<b>Impact Date:</b>	n/a

## Mitigation Plan: RT-9

<b>Activity No:</b>	<b>Description:</b>	<b>Research alternative sources of electricity for HNAABS.</b>	Planned Start Date: 9/15/2012 Actual Start Date: 9/15/2012
<b>RT-9_1</b>			
<b>Actionee:</b>	Cultivation and Refinement Team	<b>Completion Dates:</b>	Original Planned Completion Date: 10/30/2012 Actual Completion Date: ----- <b>Not Complete</b>
<b>Status:</b>	Open		
<b>Comment:</b>	After completion of the AoA findings, Cultivation/Refinement factored energy usage into the decision process, but it's still adding to the power grid that is already overtaxed. The next capstone team will require reviewing RT-9 and need to double check findings.		
<b>Activity No:</b>	<b>Description:</b>	<b>Research self-sufficient alternatives to refinement.</b>	Planned Start Date: 9/15/2012 Actual Start Date: 9/15/2012
<b>RT-9_2</b>			
<b>Actionee:</b>	Refinement Team	<b>Completion Dates:</b>	Original Planned Completion Date: 10/30/2012 Actual Completion Date: ----- <b>Not Complete</b>
<b>Status:</b>	Open		
<b>Comment:</b>	After completion of the AoA findings, Cultivation/Refinement factored energy usage into the decision process, but it's still adding to the power grid that is already overtaxed. The next capstone team will require reviewing RT-9 and need to double check findings.		
<b>Activity No:</b>	<b>Description:</b>	<b>Research self-sufficient alternatives to cultivation.</b>	Planned Start Date: 9/15/2012 Actual Start Date: 9/15/2012
<b>RT-9_3</b>			
<b>Actionee:</b>	Refinement Team	<b>Completion Dates:</b>	Original Planned Completion Date: 10/30/2012 Actual Completion Date: ----- <b>Not Complete</b>
<b>Status:</b>	Open		

---

**Comment:** After completion of the AoA findings, Cultivation/Refinement factored energy usage into the decision process, but it's still adding to the power grid that is already overtaxed. The next capstone team will require reviewing RT-9 and need to double check findings.

---

## TRACKED RISKS (CONTINUED)

The following risk information was collected and recorded in Microsoft Excel format and IAW with the RMP. The accumulated information is updated during RMT briefing to ensure concurrence among peers on tracking/monitoring risks. The raw excel spreadsheet provides a compatible format for entry of the risk specified in this appendix.

### MITIGATION PLAN WITH FINAL OUTCOME FROM ANALYSIS

Title	Risk Owner	Risk Tracking Number (RT):	Mitigation Plan	Comment: Outcome/Breakdown
Hydrocracking power requirement can be expensive	Refinement	RT-1	Determine Hawaii's power consumption restrictions and utilized internal refinery power generation to lower the electrical requirement for the grid.	HNAABS refinery will generate its own energy similar to a petroleum crude refinery.
			Determine the associated cost with the variations of power consumption.	Refinement team developed a power utilization estimate for the cost team that determined power required to refine a barrel of crude oil. A refinery on average only uses 2% of their energy from external electrical sources.
			Determine internal power generation options, (if necessary) need to purchase power, and acquire the required delta to maintain/increase efficiency, and reduce costs.	Internal generation of energy is expected to be up to 60% of our required energy and 32% of our required electricity. Heat Energy from the Waste Management Facility can be captured and utilized in refinement process

Non-usable waste byproduct disposal	Refinement	RT-2	Identify what waste byproducts are being produced, how much and what to do with them; dispose, recycle and/or collect/store.	Data collected and submitted in report. Waste product data of a refinery has been collected and documented in the final report.
			Define allowable waste output.	Worked with the Environmental Team. The refinery must abide by Resource Conservation & Recovery Act, Clean Water Act, and Clean Air Act. All information was submitted with final report and risk assessment.
			Define environmental and health regulations regarding waste.	Worked with the Environmental Team. All regulatory information has been addressed in the final report.
			Research existing refineries waste by-product outputs. Research possibly shipping waste out of Hawaii.	Waste products of the refinery will be documented in the final report
If an existing refinery cannot be converted to meet KPPs, then a new refinery may need to be built.	Refinement	RT-3	Determine what refineries exist in Hawaii.	Existing Refineries have been studied with Tesoro remaining as a potential site.
			Determine existing refineries size, fuel/bio-fuel output, bio-oil being refined, etc.	Data collected.
			Research conversion requirements and identify potential issues	Conversion requirements have been determined, and some issues have been identified (Honeywell Report would give detail). Issues have been identified. All are documented in the final report
			Perform trade-off analysis of existing refineries versus building a new refinery	Final report discusses pros/cons with building new or retrofitting an existing refinery.
			Define TRL of bio refinery.	The operation of the bio-refinery in Geismar, LA has the TRL of 8.
Cultivation Technical Maturity Risk	Cultivation	RT-5	Determine scalability of major current laboratory methods for sustainability in a large scale production environment.	Choose PBR (vice OMEGA), microfiltration, flash drying, and quantum fracturing for a large scale production environment.

			Define TRL of cultivation.	The technology is mature enough to proceed to recommend design of algal cultivation system.
Capital costs for new refinery not profitable enough for public interest	Cost	RT-4	Assess current Hawaiian facilities landscape early. Request waivers for expedited funding.	Recommendation to use: hybrid and retrofit facilities and govt. to partner with corporate entity in Hawaii
Cultivation Land Resource Risk	Cultivation	RT-6	Identify land available and make trade-off where necessary (non-ideal sloping, sunlight, resource, distance, etc...)	This is still a risk and will need to continue risk management process going forward. Review Land availability and social acceptance in Hawaii.
Cultivation CO2 Risk	Cultivation	RT-7	Perform trade-off analysis of methods and land available to optimize CO2 usage from all available resources that are ideal for various cultivation methods.	This is still a risk and will need to continue risk management process going forward. Review Land availability and social acceptance in Hawaii.
Invasive Algae species	Cultivation/ Environmental	RT-8	Use Closed systems (Bio-reactor).	Mitigate by using algae species not on the banned algae list.
			Test/Inspect algae species in pond (if used).	After AoA analysis, the pond was not recommended as a suitable growth system.
Sufficient overhead in Hawaii Electrical Infrastructure	Cultivation/ Refinement	RT-9	Research alternative sources of electricity for HNAABS.	After completion of the AoAs, the cultivation/refinement energy usage was factored into the decision process, but its still adding to the power grid that is already over taxed. Recommend the next capstone team to review RT-9 and need to double check current findings to see if there is an acceptable alternative and/or recommend a different approach.
			Research self-sufficient alternatives to refinement.	
			Research self-sufficient alternatives to cultivation	

## APPENDIX H. ACCEPTED RISK

Submitted by	(Reported) Risk#	Title	Risk Reporting Matrix	Mitigation Plan	Assignee	Risk Technique
Requirement	2	HNAABS Schedule Risk Due to Late Deliverables from Sub-teams	(4,4)	Assign IMS POC to monitor schedule due dates	Requirement	Acceptance
Requirement	3	HNAABS will be affected by Trade-Wind & Rainfall	(4,4)	Research structural requirements for build sites Research optimum rainfall locations for sites	Refinement /Cultivation Cultivation	Acceptance
Requirement	4	HNAABS will be affected by trade-winds	(4,4)	Research structural requirements for build sites	Refinement /Cultivation	Acceptance

THIS PAGE INTENTIONALLY LEFT BLANK

## APPENDIX I. AOA RISK SUBMISSION

Submitted by	(Reported) Risk#	Title	Risk Reporting Matrix	Mitigation Plan	Assignee
AOA-4 Oil Extraction (sent by: Mark Relova)	1	Use of Hexane in Oil Extraction may cause Issues	(4,4)	N/A- wait until more info is available from AoA report	Cultivation: AoA-4 team
AoA-4 Oil Extraction (Mike Rodgers)	1	Global DME Capacity	(3,3)	Determine DME suppliers near Hawaii for potential contracting opportunities.	Cultivation: AoA-4 team
AoA-4 (Joseph Kamara)	2	Algae nutrients	(3,3)	Maintain and recycle the Nitrogen and Phosphorous that are used as catalyst and recovered from the lipid extracted algae.	Cultivation: AoA-4 team
AoA-4 (Drew Janicek)	3	Unknown Impact on Oil Quality with Ultrasonic Lysing	(3,4)	Contact companies and perform further research to determine any degradation from Ultrasonic Lysing	Cultivation: AoA-4 team
AoA-4 (Drew Janicek)	4	Power and Scalability for Ultrasonic Lysing	(2,5)	Determine the flow rate that is needed to meet the requirements of the project and translate that into scalability and power required to operate the system. Then perform a cost	Cultivation: AoA-4 team

				analysis to determine if it is a feasible process.	
AoA-4 (Drew Janicek)	5	Ultrasonic Lysing and its dependency on other Processes	(3,3)	Determine if Ultrasonic Lysing can be a stand-alone process, given the algal cell structure used in the cultivation system, to be sufficient enough to release the oil.	Cultivation: AoA-4 team
AoA-2 Harvest Method (Julie M.)	1	Costs Associated with use of Chemicals to Aid in Flocculation Process	(4,3)	N/A- wait until more info is available from AoA report	Cultivation: AoA-2 team
AoA-2 Harvest Method (Julie M.)	2	Use of Chemicals to Aid in Flocculation Process	(2,5)	N/A- wait until more info is available from AoA report	Cultivation: AoA-2 team
AoA-2 Harvest Method (Julie M.)	3	TRL Level of Non-Chemical Flocculation Processes	(3,4)	N/A- wait until more info is available from AoA report	Cultivation: AoA-2 team

## APPENDIX J. FUTURE RISK ASSESSMENT

Submitted by	(Reported) Risk#	Title	Risk Reporting Matrix	Mitigation Plan
Environmental Team	2	Regulation or statute changes	(3,3)	Monitor legislation for conflicts
Environmental Team	3	Air Emissions from Refinement site exceeding acceptable levels	(2,5)	Gather air quality samples and test/measure
				Build air scrubbers/smoke stacks to clean air
				Benchmark other refineries in Hawaii
Environmental Team	4	Untreated wastewater discharge	(2,4)	Daily inspection of wastewater system and treatment facility
				Reinforce seals, walls, barriers
Environmental Team	5	Consuming too much water in the algae biofuel production region	(2,4)	Develop system that utilizes less water consumption
				Recycle wastewater back into the system
				Use water from the ocean
Environmental Team	6	Conflicts of Land Use	(3,3)	Use lessons learned from existing bio-energy development in HI.
				Adhere to all litigate measures & strive for community acceptance.

## APPENDIX K. HNAABS CULTIVATION AOA TEAMS



## APPENDIX L. NON-TRACKED RISKS CLOSED

Submitted by	(Reported) Risk#	Title	Risk Reporting Matrix	Mitigation Plan	Assignee	Review/Comment
AoA-4 Oil Extraction (sent by: Mark Relova)	1	Use of Hexane in Oil Extraction may cause Issues	(4,4)	N/A- wait until more info is available from AoA report	Cultivation: AoA-4 team	Closed- not using this method.
AoA-4 Oil Extraction (Mike Rodgers)	1	Global DME Capacity	(3,3)	Determine DME suppliers near Hawaii for potential contracting opportunities.	Cultivation: AoA-4 team	Closed- not using this method.
AoA-4 (Joseph Kamara)	2	Algae nutrients	(3,3)	Maintain and recycle the Nitrogen and Phosphorous that are used as catalyst and recovered from the lipid extracted algae.	Cultivation: AoA-4 team	Closed- Research revealed that there is no concern with this risk.
AoA-4 (Drew Janicek)	3	Unknown Impact on Oil Quality with Ultrasonic Lysing	(3,4)	Contact companies and perform further research to determine any degradation from Ultrasonic Lysing	Cultivation: AoA-4 team	Closed- not using this method.

AoA-4 (Drew Janicek)	4	Power and Scalability for Ultrasonic Lysing	(2,5)	Determine the flow rate that is needed to meet the requirements of the project and translate that into scalability and power required to operate the system. Then perform a cost analysis to determine if it is a feasible process.	Cultivation: AoA-4 team	Closed- not using this method.
AoA-4 (Drew Janicek)	5	Ultrasonic Lysing and its dependency on other Processes	(3,3)	Determine if Ultrasonic Lysing can be a standalone process, given the algal cell structure used in the cultivation system, to be sufficient enough to release the oil.	Cultivation: AoA-4 team	Closed- not using this method.
AoA-2 Harvest Method (Julie M.)	1	Costs Associated with use of Chemicals to Aid in Flocculation Process	(4,3)	N/A- wait until more info is available from AoA report	Cultivation: AoA-2 team	closed- recommendation is to use microfiltration for harvesting
AoA-2 Harvest Method (Julie M.)	2	Use of Chemicals to Aid in Flocculation Process	(2,5)	N/A- wait until more info is available from AoA report	Cultivation: AoA-2 team	closed- recommendation is to use microfiltration for harvesting

AoA-2 Harvest Method (Julie M.)	3	TRL Level of Non-Chemical Flocculation Processes	(3,4)	N/A- wait until more info is available from AoA report	Cultivation: AoA-2 team	closed-recommendation is to use microfiltration for harvesting
---------------------------------	---	--	-------	--	-------------------------	--

## LIST OF REFERENCES

- A Barrel Full. 2013. "Chevron Honolulu Hawaii Refinery." Accessed March 25.  
<http://abarrelfull.wikidot.com/chevron-honolulu-hawaii-refinery>.
- Abbotts, Douglas. 2012. "Navy Surges Toward Energy Independence." *Currents*, Spring Issue. Chief of Naval Operations Energy and Environmental Readiness Division.  
[http://greenfleet.dodlive.mil/files/2012/01/Currents\\_Spring\\_2012\\_SMALL.pdf](http://greenfleet.dodlive.mil/files/2012/01/Currents_Spring_2012_SMALL.pdf)
- Acien, F.G., J.M. Fernandez, C. Gonzalez, and E. Molina Grima. 2010. "Microalgae Production Costs." Presentation at the AquaFUELS Round Table. Brussels, Belgium, October 21–22.
- Advameg Inc. 2013. "Pollution Issues: Petroleum." Accessed March 5.  
<http://www.pollutionissues.com/Na-Ph/Petroleum.html>.
- Aguiar, Eloise. 2007. "More Native Hawaiian Bones Unearthed at Site." *Honolulu Advertiser*, Last modified October 24.  
<http://the.honoluluadvertiser.com/article/2007/Oct/24/ln/hawaii710240417.html>.
- Akao, Yoji. 1994. "Development History of Quality Function Deployment." In *QFD, The Customer Driven Approach to Quality Planning and Deployment*, edited by Shigeru Mizuno and Yoji Akao, 339. Tokyo, Japan: Asian Productivity Organization.
- Alabi, Abayomi O., Martin Tampier, and Eric Bibeau. 2009. *Microalgae Technologies and Process for Biofuels/Bioenergy Production in British Columbia: Current Technology, Suitability, and Barriers to Implementation*. Final report submitted to The British Columbia Innovation Council, Manitoba, January 14
- Algae Energy. 2013. "Cultivation." Accessed March 25.  
[http://algae-energy.co.uk/biofuel\\_production/cultivation/](http://algae-energy.co.uk/biofuel_production/cultivation/).
- Algae Industry Magazine. 2013. "OriginOil Extraction Process Reaches 97% Efficiency." Accessed January 20.  
<http://www.algaeindustrymagazine.com/originoil-extraction-process-reaches-97-efficiency/>.
- Allison, Marc, Joe L. Outlaw, and James W. Richardson. 2010. "The Economics of Microalgae Oil." *The Journal of Agrobiotechnology Management and Economics* 13:119-130.
- Aloha Petroleum Ltd. 2013. "Aloha Petroleum Ltd." Accessed March 25.  
<http://www.alohagas.com/>.

- ALSTOM Power Inc. Air Preheater Company. 2013. "Products: Flash Dryers." Accessed January 15. <http://www.airpreheatercompany.com/Products/Category.aspx?cat=6>.
- Amos, Wade A. 1998. *Report on Biomass Drying Technology*. National Renewable Energy Laboratory. NREL/TP-570-25885
- Annamalai, Kalyan and Ishwar K. Puri. 2006. *Combustion Science and Engineering*. New York: CRC Press.
- Aulenbach, Selke, Shammass, and Wang. 2010. *Flotation Technology: Handbook of Environmental Engineering Volume 12*. Totowa, NJ: Humana Press.
- Austin, Ed. 2010. "OMEGA Status." *Aeronautics Research Mission Directorate Green Aviation Summit*. NASA.
- Bahill, Terry A., and William L. Chapman. 1993. "A Tutorial on Quality Function Deployment." *Engineering Management Journal* 5: 24–35.
- Becker, E.W. 1993. *Microalgae: Biotechnology and Microbiology*, by E.W. Becker, 22. Cambridge, MA: Cambridge University Press.
- Beychok, Milton. 2013. "Fundamentals of Stack Gas Dispersion." Accessed March 25. <http://www.air-dispersion.com>
- Bilad, M.R., I. Foubert, K. Muylaert, D. Vandamme, and I.F.J. Vankelecom. 2011. *Evaluation of Submerged Microfiltration Process to Harvest Freshwater and Marine Microalgae*. Kortrijk, Belgium: Lab Aquatic Biology.
- Biofuels Journal. 2008. "Dynamic Fuels LLC Breaks Ground at Geismar, LA Biodiesel Plant." Last modified October 8. [http://www.biofuelsjournal.com/articles/Dynamic\\_Fuels\\_LLC\\_Breaks\\_Ground\\_at\\_Geismar\\_\\_LA\\_Biodiesel\\_Plant\\_Site\\_-64336.html](http://www.biofuelsjournal.com/articles/Dynamic_Fuels_LLC_Breaks_Ground_at_Geismar__LA_Biodiesel_Plant_Site_-64336.html).
- Blanchard, Benjamin S. and Wolter J. Fabrycky. 2010. *Systems Engineering and Analysis*. 5th. Upper Saddle River, NJ: Prentice Hall.
- Bloomberg. 2013. "Bloomberg Energy and Oil Prices." Accessed February 5. <http://www.bloomberg.com/energy/>.
- Bogar, Frederick D, John R Clendenning, Ahron Gibor, and Gilbert V Levin. 1961. *Harvesting of Algae by Froth Flotation*. Washington DC: Resources Research
- Brennan, Liam and Philip Owende. 2009. "Biofuels from microalgae - A review of technologies for production, processing, and extractions of biofuels and co-products." *Renewable and Sustainable Energy Reviews* 14: 557-577.

- Britannica. 2012. "Britannica Encyclopedia." Accessed September 7.  
<http://kids.britannica.com/comptons/art-53784>.
- Brown, Tom. 2009. "Bio-Based Jet Fuel Studies a 'GR8' (Great R-8) Success." Last modified October 27.  
<http://www.wpafb.af.mil/news/story.asp?id=123174617>.
- Browne, B., Gibbs, R., McLeod, J., Parker, M., Schwanda, W., Warren, K. 2010. *Oil Extraction from Microalgae*. Capstone Project Report, Orono, ME: University of Maine.
- Bunting, Bruce, Mike Bunce, Teresa Barone, and John Storey. 2010. *Fungible and Compatible Biofuels*. Oak Ridge, TN: Oak Ridge National Laboratory.
- Bureau of Labor Statistics. 2013. "Industries at a Glance: Oil and Gas Extraction Prices." Last modified March 22. <http://www.bls.gov/iag/tgs/iag211.htm#prices>.
- California Energy Commission. 2012. *New Microalgae Fermentation Process Used to Produce Biofuel*. Sacramento, CA: Californian Energy Department.
- California Urban Water Conservation Council. 2011. *The Petroleum Refining and Chemical Industries in California*. Sacramento, CA: CUWCC.
- California Water Service Group. 2013. *Hawaii Water Service Company*. Accessed March 25.  
<http://www.hawaiiwaterservice.com/>.
- Carlson, Liane, Michael Lee, Chukuemeka Oje, and Arthur Xu. 2010. *Algae to Alkanes*. University of Pennsylvania, Department of Chemical and Biomolecular Engineering Senior Design Report.
- Central Research Institute of the Electric Power Industry. 2010. "Press Release - 2010.3.17." March 17.  
[http://criepi.denken.or.jp/en/activities/pressrelease/2010/03\\_17.pdf](http://criepi.denken.or.jp/en/activities/pressrelease/2010/03_17.pdf).
- Chevron. 2012. *United States Fact Sheet*. San Ramon, California: Chevron Corporation. Last Modified April 2012.  
<http://www.chevron.com/Documents/Pdf/UnitedStatesFactSheet.pdf>
- Chillingworth, Mele, and Scott Q. Turn. 2011. *Analysis of Land Suitable for Algae Production State of Hawaii*. Hawaii Natural Energy Institute. DE-FC26-06NT42847
- Christiansen, Ove B., and Mary Suterardo. 2001. "Find the Optimum Flash Dryer to Remove Surface Moisture." *Chemical Engineering Progress Magazine*: 54-58.

- Citizendium. 2012. "Hydrocracking." Last modified November 20.  
<http://en.citizendium.org/wiki/Hydrocracking>.
- City and County of Honolulu. 2013. "Honolulu Board of Water Supply." Accessed March 25.  
<http://www.hbws.org/cssweb/>.
- Clearwater Industries, Inc. 2013. "Clearwater Industries, Inc. Frequently Asked Questions." Accessed February 18.  
<http://www.clearwaterind.com/pages/FAQs.html>.
- Cleveland, Cutler J., and Rosemarie Szostak. 2011. "Catalytic Hydrotreating in Petroleum Refining." Last modified October 9.  
[http://www.eoearth.org/article/Catalytic\\_hydrotreating\\_in\\_petroleum\\_refining?to\\_pic=74180](http://www.eoearth.org/article/Catalytic_hydrotreating_in_petroleum_refining?to_pic=74180).
- Cohen, Ronnie, Barry Nelson, and Gary Wolff. 2004. *Energy Down the Drain: The Hidden Costs of California's Water Supply*. Oakland, CA: Natural Resources Defense Council.  
<http://www.nrdc.org/water/conservation/edrain/edrain.pdf>.
- Commission on Water Resource Management. 2013. "Hawaii Water Plan - Department of Land and Natural Resources." Accessed February 11.  
[http://www.state.hi.us/dlnr/cwrw/planning\\_hiwaterplan.htm](http://www.state.hi.us/dlnr/cwrw/planning_hiwaterplan.htm).
- Commodo, Mario, Ivo Fabris, Clinton Groth, and Omer L. Gulder. 2011. "Analysis of Aviation Fuel Thermal Oxidative Stability by Electrospray Ionization Mass Spectrometry (ESI-MS)." *Energy Fuels* 25: 2142-2150.  
[http://utias.utoronto.ca/~ogulder/Z\\_Energy&Fuels2011\\_JetFuelStab.pdf](http://utias.utoronto.ca/~ogulder/Z_Energy&Fuels2011_JetFuelStab.pdf)
- CommonWealth REIT. 2005. "HRPT to Purchase Campbell Industrial Park Lands in Hawaii for \$115.5 Million, news release, Last modified February 17.  
<http://investor.shareholder.com/hrpreit/releasedetail.cfm?releaseid=340761>.
- Conjecture Corporation. 2013. "What is Decantation." Accessed March 25.  
<http://www.wisegeek.com/what-is-decantation.htm>.
- Conklin, Kenneth R. Ph.D. 2007. "Hawaiian Bones - The 3 Rs - Rites For the Dead, Rights Of the Living, and Respect for All." Last modified July 20.  
<http://www.angelfire.com/planet/big60/HawaiianBonesDetailed.html>.
- Cooper, George, and Gavan Daws. 1990. *Land and Power in Hawaii: The Democratic Years*. University of Hawaii Press.
- Cooper, Jeanne. 2012. "Hawaii's Top 10 Largest Landowners." Last modified June 29.  
<http://www.sfgate.com/hawaii/alohafriday/article/Hawaii-s-top-10-largest-landowners-3671077.php>.

- County of Hawai'i Department of Environmental Management. 2013. "County of Hawai'i Solid Waste Facilities." Accessed January 25.  
<http://www.hawaiizerowaste.org/facilities/>.
- Cranfield University. 2012. "Oasis Network Downloads." Last modified March 15.  
[http://www.oasisnetwork.co.uk/downloads/OASIS\\_Supplier\\_pack\\_2.docx](http://www.oasisnetwork.co.uk/downloads/OASIS_Supplier_pack_2.docx).
- Crown Iron Works Company. 2012. "Flash Dryer." Last modified October 29.  
[http://www.crowniron.com/technologies/flash\\_dryers.cfm](http://www.crowniron.com/technologies/flash_dryers.cfm).
- Cuevas, Monica B. Perez, Krisada Ruanjaikaen, and Andrew L. Zydney. 2011. "Microfiltration of Microalgae for Biofuel Production." Poster presentation from Department of Chemical Engineering, The Pennsylvania State University, University Park, Pennsylvania.  
[http://www.che.psu.edu/reu2/archive/2011/monica\\_perez\\_reu\\_poster.pdf](http://www.che.psu.edu/reu2/archive/2011/monica_perez_reu_poster.pdf)
- Custer, James. 2007. *Algae: America's Pathway to Independence*. Strategy Research Project, Carlisle, PA: United States Army War College. DTIC (ADA469390)
- Dart, Andrew K. 2012. "Past, Present and Future Oil Prices." Last modified December 8.  
<http://www.akdart.com/oil5.html>.
- Darzins, Al, and Eric P Knoshaug. 2011. "Algae Biofuels: The Process." *Chemical Engineering Progress Magazine*. American Institute of Chemical Engineers.
- Daysog, Rick. 2013. "Tesoro Hawaii Refinery to Shut Down, 200 Jobs to be Lost." Last modified January 9.  
<http://www.hawaiinewsnow.com/story/20534951/tesoro-hawaii-refinery-to-shut-down-200-will-lose-jobs>.
- Defense Acquisition University. 2012. "Defense Acquisition Guidebook." January 28.  
<https://acc.dau.mil/CommunityBrowser.aspx?id=289207&lang=en-US>.
- . 2011. "Risk Definition." Accessed December 29, 2012.  
<https://acc.dau.mil/CommunityBrowser.aspx?id=19182>.
- . 2009. "Risk Management Plan Template and Guide." Accessed July 22, 2012.  
[https://acc.dau.mil/adl/en-US/180602/file/45037/EI\\_risk\\_mgmt\\_plan\\_template\\_guide.doc](https://acc.dau.mil/adl/en-US/180602/file/45037/EI_risk_mgmt_plan_template_guide.doc).
- DeHaan, Patrick. 2010. "What it Takes to Power U.S. Refineries." January 29.  
<http://blog.gasbuddy.com/posts/What-it-takes-to-power-U-S-refineries/1715-397564-218.aspx>.
- Department of Geography; University of Hawai'i at Manoa. 2013. "Mean Annual Rainfall Island of Hawai'i." Accessed February 12.  
[http://www.hiloagent.com/images/Hawaii\\_Island\\_Rainfall.jpg](http://www.hiloagent.com/images/Hawaii_Island_Rainfall.jpg).

- Dolbear, Geoffrey E. and John S. Magee. 1998. *Petroleum Catalysts in Nontechnical Language*. Pennwell Books.
- Dryden Aqua Technology Ltd. 2013. "Decanter for Effluent Sedimentation." Accessed January 21.  
[http://www.drydenaqua.com/equipment/products/decanter/index\\_decantor.htm](http://www.drydenaqua.com/equipment/products/decanter/index_decantor.htm).
- Duan, Peigao and Phillip E. Savage. 2011. "Catalytic hydrotreatment of crude algal bio-oil in supercritical water." *Applied Catalysis* 104: 136-143.
- Dunford, Nurhan Turgut. 2008. *Engineering Aspects of Biodiesel Production Process*. Oklahoma State University.  
<http://fapc.okstate.edu/files/biodiesel/biodiesellecture.pdf>
- Dynamic Fuels, LLC. 2010. "Dynamic Fuels, LLC Corporate Brochure." Last modified April 10.  
[http://dynamicfuelsllc.com/wp-news/wp-content/uploads/2010/05/DYNAMIC-fules\\_MAY10\\_NA\\_BROCH.pdf](http://dynamicfuelsllc.com/wp-news/wp-content/uploads/2010/05/DYNAMIC-fules_MAY10_NA_BROCH.pdf).
- Earl, William Brian, and Praveen Kumar Bhagat. 2010. Method of Distillation and/or a Distillation Column. United States of America Patent 20100163400. July 1.
- Easterly, James L. 2002. *Assessment of Bio-Oil as a Replacement for Heating Oil*. Fairfax, VA: Easterly Consulting. <http://www.nrbp.org/pdfs/pub34.pdf>
- Eckelberry, Nicholas D., Michael Philip Green, and Scott Alexander Fraser. 2011. Ssystems, Apparatuses, and Methods for Extracting Non-polar Lipics from an Aqueous Algae Slurry and Lipids Produced Therefrom. United States of America Patent 20110095225. April 28.
- Energy Center of École polytechnique fédérale de Lausanne (EPFL). 2011. "Roundtable on Sustainable Biofuels Conservation Impact Assessment Guidelines." RSB-GUI-01-007-01 (version 2.0).
- EnglishInfo. 2013. "Froth Flotation." Accessed February 18.  
<http://english.turkcebilgi.com/Froth+flotation>.
- Ferguson, Suzanne, and Mike Stockle. 2012. "Carbon Capture Options for Refiners." *ePTQ Magazine* Q2 Issue: 77-87.  
<http://www.digitalrefining.com/article/1000271#.UP28mI5R6FY>.
- Flammini, Alessandro. 2011. *Algae-based Biofuels: Perspectives for developed and developing countries*. Food and Agriculture Organization of the UN (FAO).  
[http://www.fao.org/fileadmin/templates/aquaticbiofuels/PPT/Flammini\\_FAO\\_AB\\_B\\_report\\_2010\\_1.1.pdf](http://www.fao.org/fileadmin/templates/aquaticbiofuels/PPT/Flammini_FAO_AB_B_report_2010_1.1.pdf)

- FlexPVC. 2013. "FlexPVC Valves." Accessed March 8.  
<http://flexpvc.com/cart/agora.cgi?product=PVC-Valves-Gate>.
- Foltz, Garrett. 2012. *Algae Lysis with Pulsed Electric Fields*. San Luis: California Polytechnic State University.
- Food and Agriculture Organization of the United Nations. 1997. *Renewable biological systems for alternative sustainable energy production*. Services Bulletin, FAO.
- Freudenrich, Craig. 2001. "How Oil Refining Works." Last modified January 4.  
<http://science.howstuffworks.com/environmental/energy/oil-refining4.htm>.
- Garofalo, Raffaello. 2011. *Algae and aquatic biomass for a sustainable production of 2nd generation biofuels*. Economic Assessment, AquaFUELS.
- Gary, James H., and Glenn E. Handwerk. 2001. *Petroleum Refining*. CRC Press.
- Goebel, R. P., and J. C. Weissman. 1985. *Design and Analysis of Microalgal Open Pond Systems*. Technical Report, Solar Energy Research Institute.
- Goh, A, T.S. Sim, and E.W. Becker. 1988. "Comparison of Centrifugation, Dissolved Air Flotation, and Drum Filtration Techniques for Harvesting Sewage-grown Algae." *Biomass* 16: 51-62.
- Goldenberg, Suzanne. 2010. "Algae to Solve the Pentagon's Jet Fuel Problem." Last modified February 13.  
<http://www.algaeindustrymagazine.com/darpa-closes-in-on-2gal-algae-fuel/>.
- Grant, Bob. 2009. "Future Oil." *The Scientist* 23: 36. <http://www.the-scientist.com/?articles.view/articleNo/27097/title/Future-Oil/>
- Green, M., G. Shelef, and A. Sukenik. 1984. *Microalgae Harvesting and Processing: A Literature Review*. Haifa, Israel: Technion Research and Development Foundation Ltd. <http://www.nrel.gov/docs/legosti/old/2396.pdf>
- Grima, E. Molina, E.H. Belbar, Acien F.G. Fernandez, A Robles Medina, and Yusuf Chisti. 2003. "Recovery of Microalgal Biomass and Metabolites: Process Options and Economics." *Biotechnology Advances* 20: 491-515.
- Hashimoto, Andrew G., interview by Karolyn Campbell, Joseph Sweeney, Roge Adversalo Scott Brown. 2012. *Professor; University of Hawaii; Director of Molecular and Bioengineering* (September 6).
- Hauser, John R., and Don Clausing. 1988. *The House of Quality*. Harvard Business Review.

- Havrin, Robert G. 2013. "The Comparison and Selection of Separations Equipment for the Municipal Industry (Centrifuges versus Belt Filters)." Accessed February 18. <http://centrisys.us/uploads/PDFS/Centrifuges%20vs%20Belt%20Filters.pdf>.
- Hawai'i Biofuel Foundation and NCSI Americas Inc. 2011. "Roundtable on Sustainable Biofuels Certification Readiness Study: Hawai'i Biofuel Projects." Bioenergy Analyses.
- Hawaii Congress of Planning Officials. 2012. "Algae Biofuel Development in Hawaii." Presentation dated September for the Honolulu Department of Planning and Permitting.
- Hawaii Department of Health. 2012. "Hawaii Administrative Rules Title 11 Department of Health Chapter 281 Underground Storage Tanks." Last modified June 1. <http://gen.doh.hawaii.gov/sites/har/AdmRules1/11-281.pdf>.
- . 2011. "Hawaii Administrative Rules Amendment and Compliation of Chapter 11-60.1 Air Pollution Control." Last modified December 20. [http://co.doh.hawaii.gov/sites/cab/draft/har\\_11-60\\_1.pdf](http://co.doh.hawaii.gov/sites/cab/draft/har_11-60_1.pdf).
- . 1997. "Chapter 11-62 Appendix A - Individual and General Permit Standard Conditions." Last modified April 15. <http://gen.doh.hawaii.gov/sites/har/AdmRules1/11-62a.pdf>.
- Hawaii Foreign-Trade Zone. 2013. "Chevron Foreign Trade Zone 9." Accessed March 25. <http://www.ftz9.org/index.php?action=58>.
- Hawaii Foreign-Trade Zone. 2013. "Tesoro Foreign Trade Zone 9." Accessed March 25. <http://www.ftz9.org/index.php?action=57>.
- Hawaii Petroleum. 2013. *About Us*. Accessed March 25. <http://www.hawaiipetroleum.com/aboutus.php>.
- Hawaii Renewable Energy Development Venture. 2013. "Algae Biomass for Biofuel Production." Accessed February 08. <http://www.hawaiiirenewable.com/investments/kuehnle-agrosystems/>.
- Hawaii Stage Energy Office. 2013. "Federal and State Approvals for Bioenergy – Hawaii Renewable Energy Permits and Approvals Guidebooks." Accessed March 25. <http://energy.hawaii.gov/permitting/renewable-energy-project-permitting/>.
- Hawaiian Electric Company. 2013. "Average Electric Rates for Hawaiian Electric Co., Maui Electric Co. and Hawaii Electric Light Co." Accessed January 15. <http://www.heco.com/portal/site/heco/menuitem.508576f78baa14340b4c0610c510b1ca/?vgnextoid=692e5e658e0fc010VgnVCM1000008119fea9RCRD&vgnnextc>

- hannel=2c65a51aaabd6110VgnVCM1000005c011bacRCRD&vgnextfmt=default  
&vgnextrefresh=1&level=0&ct=article.
- Hawai'i Clean Energy Initiative. 2013. "Hawai'i is the Most Fossil Fuel Dependent State in the Nation." Accessed February 17.  
<http://www.hawaiicleanenergyinitiative.org/>.
- Heber, Gabriele. 2013. "Simple Methods for the Treatment of Drinking Water." Accessed February 18.  
<http://collections.infocollections.org/ukedu/uk/d/Jg13sie/5.3.html>.
- Hebner, Robert E., Kent Davey, Michael D. Werst, and Rhykka Connelly. 2012. Electromechanical Lysing of Algae Cells. United States of America Patent 2012/0021481. January 26.
- Herndon, Walter R. 1963. *A Study and Investigation of New Algae Strains*. Chicago, IL: United States Army Research and Engineering Command.
- Holmgren, J., Gosling C., Marinangelli, R., Marker, P., Faraci, G., Perego, C. 2007. "New developments in renewable fuels offer more choices." *Hydrocarbon Processing* Sep 2007: 67-71. <http://www.uop.com/wp-content/uploads/2011/01/UOP-New-Development-in-Renewables-Fuels-Tech-Paper.pdf>
- Honolulu Department of Environmental Services. 2013. "ENV: Department of Environmental Services." Accessed January 28.  
<http://www.opala.org/>.
- Hunan Double Elephants Machinery Company. 2013. "Manufacturers of Screw Oil Press." Accessed February 14.  
<http://www.oilpressmachine.com/Screw-Expeller-Pressing.html>.
- IndexMundi. 2013. "Jet Fuel Monthly Price." Last modified February 10.  
<http://www.indexmundi.com/commodities/?commodity=jet-fuel&months=60>.
- Intercontinental Engineer, Ltd. 1980. *Study of Hog Fuel Drying Systems*. Canadian Electrical Association prepared by Intercontinental Engineering Ltd.
- IPIECA. 2010. "Petroleum Refining Water/Wastewater Use and Management." IPIECA report for Operations Good Practice Series, London, United Kingdom.
- Jones, Don, interview by Karolyn Campbell. 2013. *Technical Sales Manager* (January 30).
- Kadam, Kiran L. 2001. *Microalgae Production from Power Plant Flue Gas: Environmental Implications on a Life Cycle Basis*. Technical Report, Golden, Colorado: National Renewable Energy Laboratory.

- Kanduser, Masa, and Damijan Miklavcic. 2009. "Electroporation in Biological Cell and Tissue: An Overview." In *Electrotechnologies for Extraction from Food Plants and Biomaterials*, 1-37. New York, NY: Springer. <http://lbk.fe.uni-lj.si/pdfs/eefp2008.pdf>
- Karbuz, Sohbet. 2007. "U.S. Military Consumption - Facts and Figures." Last modified May 20. <http://www.energybulletin.net/stories/2007-05-21/us-military-energy-consumption-facts-and-figures>.
- Khan, Firdos Alam. 2012. *Biotechnology Fundamentals*. Boca Raton, FL: CRC Press.
- Ky, Jennifer. 2011. "Algal Biodiesel as an Energy Source?" Last modified November 18. <http://www.yalescientific.org/2011/11/algal-biodiesel-as-an-energy-source/>.
- Land Use Commission Department of Business, Economic Development, and Tourism; State of Hawaii. 2013. "State Land Use Districts." Accessed January 12. <http://luc.state.hi.us/about.htm>.
- Lardon, Laurent, Arnaud Helias, Bruno Sialve, Jean-Philippe Steyer, and Olivier Bernard. 2009. *Life-Cycle Assessment of Biodiesel Production from Microalgae*. Policy Analysis, Narbonne, France: INRA, UR50 Laboratoire de Biotechnologie de l'Environnement.
- Lawrence Berkeley National Laboratory. 2013. "Cutting Paper-Counting-Disposal." Accessed January 9. <http://energy.lbl.gov/ea/%20archived/paper-archives/paper-5-2012/counting/disposal.htm>.
- Lee, S., and Y. T. Shah. 2013. *Biofuels and Bioenergy: Processes and Technologies*. Boca Raton, FL: Taylor and Francis Group, LLC.
- Li, Hanning, and K Finney. 2010. *A Review of Drying Technologies*. Technology Review, Sheffield, England: Sheffield University Waste Incineration Centre (SUWIC).
- Liang, David T. 2005. "Management of Spent Catalysts in Petroleum Refineries." 2nd Asian Petroleum Technology Symposium Program. <http://www.scribd.com/doc/6925147/MANAGEMENT-OF-SPENT-CATALYSTS-IN-PETROLEUM-REFINERIES>.
- Lindenberg, Steven. 2011. "Integrated Biorefinery Research and Development Activity." Hawaii Clean Energy Initiative Plenary Session, Honolulu, HI: U.S. Department of Energy.
- LoopNet. 2010. "Oahu Land Portfolio." Last modified September 1. <http://www.loopnet.com/Listing/16820772/Wahiawa-Wahiawa-HI/>.

- Margaritis, A. 2007. "Centrifugation Processes." Western University Biochemical Engineering Department Lecture, Ontario, Canada.
- Marsh, Mersey, and Cindy Giannaris. 1997. "Rensselaer Polytechnic Institute: Cross-flow Microfiltration." Accessed January 25.  
<http://www.rpi.edu/dept/chem-eng/Biotech-Environ/MICROFILTRATION/filter.htm>.
- Martin, Christy. 2004. "Gaps in Hawaii's Biosecurity System: Protecting Hawaii from Invasive Species." Presentation for the National Invasive Species Information Center, Hawaii.  
<http://www.invasivespeciesinfo.gov/docs/council/HISC%20Presentation.pdf>.
- Mercer, Paula, and Roberto E. Armenta. 2011. "Developments in oil extraction from microalgae." *Euroean Journal of Lipid Scienc and Technology* 113: 539–547.  
<http://algalbiofuels.pbworks.com/f/Extraction%20Review.pdf>.
- Milner, Harold W. 1948. *The Fatty Acids Of Chlorella*. Stanford, CA: Carnegie Institution of Washington.
- Mujumdar, Arun. 2011. "Drying Technology; An Overview for ME5202." Last modified July 27.  
[http://serve.me.nus.edu.sg/arun/file/teaching/ME5202/Drying%20Technology\\_An%20Overview.pdf](http://serve.me.nus.edu.sg/arun/file/teaching/ME5202/Drying%20Technology_An%20Overview.pdf).
- . 2006. *Handbook on Industrial Drying 3rd Ed*. Boca Raton, FL: CRC Press.
- Mulumba, Nkongolo. 2012. "Tubular Photobioreactor for Microalgae Biodiesel Production." *Internation Journal of Engineering Science and Technology* 4: 703-709.
- Nabzar, Lahcen, and Jean-Luc Duplan. 2011. *A look at Water in Fuel Production - Oil Production and Refining*. Cedex, France: Energies Nouvelles.
- NASA URS. 2010. "NASA-NAVY: A Strategic Planning Discussion (OMEGA)." NASA-NAVY Meeting, Norfolk, VA.
- Naval Air Systems Command. 2008. *NAVAIRINST 5000.21B*. Policy, Patuxent River, MD: Naval Air Systems Command.
- Navy Memories Shop. 2013. "Oahu Red Hill." Accessed March 25.  
<http://navy.memoriesshop.com/World-Ports/Hawaii/Red-Hill.html>.
- Obbard, Jeff. 2011. "Cellana LLC Presentation." Company presentation for the Ocean Institute. Oahu, Hawaii.

- Oilgae. 2013. "Algal Oil Yields." Accessed February 14.  
<http://www.oilgae.com/algae/oil/yield/yield.html>.
- . 2013. "Extraction of Algal Oil by Mechanical Methods." Accessed February 14.  
<http://www.oilgae.com/algae/oil/extract/mec/mec.html>.
- . 2012. "Centrifugation." Accessed November 8.  
<http://www.oilgae.com/algae/har/cen/cen.html>.
- . 2012. "Cultivation of Algae in a Photobioreactor." Accessed November 19.  
<http://www.oilgae.com/algae/cult/pbr/pbr.html>.
- . 2012. "Flocculation." Accessed December 8, 2012.  
<http://www.oilgae.com/algae/har/flc/flc.html>.
- . 2008. "Simgae Low Cost Algae Production System." Last modified December 13.  
<http://www.oilgae.com/blog/2008/12/simgae-low-cost-algae-production-system.html>.
- OriginOil, Inc. 2011. "OriginOil Receives Increased Order for Large-Scale Algae Extraction System." Last modified August 12.  
<http://www.originoil.com/company-news/originoil-receives-increased-order-for-large-scale-algae-extraction-system.html>.
- OriginOil, Inc. 2013. "Company Presentation." OriginOil company update and presentation Los Angeles, California. February 20.
- Osborne, Allison Lenore. 2009. "Harvesting Microalgae for Biofuel: Processes and Mechanisms." M.S. thesis, The University of Texas at Austin.  
<http://repositories.lib.utexas.edu/handle/2152/ETD-UT-2009-12-711>.
- Padosa. 2009. "NYSERDA Commercial Industrial Rebate Programs." Last modified May 15. <http://www.padosa.com/reference-library-energy-types-buildings/energy-types/nysesda-commercialindustrial-rebate-programs>.
- Parr Instrument Company. 2013. "Cell Disruption." Accessed February 15.  
<http://www.parrinst.com/products/sample-preparation/cell-disruption/>.
- PB Water. 2001. *Final Report Project Cost Estimate Peer Review of Microfiltration Supplemental Technology Demonstration Project*. Technology Demonstration Project, Milian, Swain, & Associates, Inc.
- Pellegrino, Joan, Sabine Brueske, Tracey Carole, and Howard Andres. 2007. *Energy and Environmental Profile of the U.S. Petroleum Refining Industry*. Columbia: Energetics Incorporated.

- Phukan, Mayur M., Rahul S. Chutia, B.K. Konwar, and R. Kataki. 2011. "Microalgae Chlorella as a potential bio-energy feedstock." *Applied Energy* 88: 3307-3312.
- Praxair, Inc. 2009. "Praxair Material Safety Data Sheet." Praxair MSDS Worldwide MSDS Library.
- Raleigh, C. B., and A. Kuehnle. 2009. *Laboratory and Large-Scale Screening and Production of Marine Algae in Hawaii for*. HR BioPetroleum, Inc.
- Rasoul-Amini, Sara, Nima Montazeri-Najafabady, Mohammad Ali Mobasher, Samira Hoseini-Alhashemi, and Younes Ghasemi. 2011. "Chlorella sp.: A new strain with highly saturated fatty acids for biodiesel production in bubble-column photobioreactor." *Applied Energy* 88: 3354-3356.
- ReThink Factory. 2013. "ReThinkFactory.org Energy Systems." Accessed January 15. <http://www.rethinkfactory.org/flagallery/energy-systems/>.
- Rocky Mountain Institute. 2006. *Hawaii Biofuels Summit Technical Synopsis*. State of Hawaii Department of Business, Economic Development, and Tourism.
- Roos, Carolyn. 2008. *Biomass Drying and Dewatering for Clean Heat and Power*. Northwest Combined Heat and Power Application Center.
- Ryan, Catie. 2009. *Cultivating Clean Energy: The Promise of Algae Biofuels*. Commissioned Report, New York City: Natural Resources Defense Council.
- Saaty, Thomas L. 2008. "Decision Making with the Analytic Heirarchy Process." *International Journal of Services Sciences* 1: 83-98.
- Samanya J., Andreas Hornung, Mark Jones, and Peter Vale. 2011. "Thermal Stability of Sewage Sludge Pyrolysis Oil." *International Journal Of Renewable Energy Research* 1: 66-74.
- Sapphire Energy. 2009. *Renewable, Scalable, Algal-Derived Liquid Transportation Fuels*. Houston, TX: Sapphire Energy.
- Sathe, Suraj. 2013. "Culturing and Harvesting Marine Microalgae for the Large-scale Production of Biodiesel." M.S. thesis, The University of Adelaide. . <http://digital.library.adelaide.edu.au/dspace/bitstream/2440/73008/1/02whole.pdf>.
- Scherzer, Julius, and A.J. Gruia. 1996. *Hydrocracking Science and Technology*. New York, NY: Marcel Dekker Inc.
- Schwartz, Viviane. 2000. "Preperation and Reactivity of Niobium-Containing Hydrotreating Catalysts." PhD dissertation, Virginia Tech University.

- Schwarzenegger, Arnold, Alan C. Lloyd, Maureen Gorsen. 2006. *California Petroleum Refinery Hazardous Waste Source Reduction 2002 Assessment Report*. Office of Pollution Prevention and Technology Department. Doc. No. 547
- Science Applications International Corporation. 2010. *Biofuels – Cellulosic and Algal Feedstocks, Final Report – Phase I*. Government Contract, Arlington, VA: Defense Advanced Research Projects Agency.
- Seymour, Thomas P. 2009. *Algae-Based Jet Fuel: The Renewable Alternative to the Air Force's Focus on Coal-to-Liquid Synthetic Fuel*. Alabama: Air Command And Staff College Air University Maxwell Air Force Base.
- Sheehan, John, Terri Dunahay, John Benemann, and Paul Roessler. 1998. *Aquatic Species Program - Biodiesel from Algae*. Golden, Colorado: National Renewable Energy Laboratory.
- Shimogawa, Duane. 2013. "Tesoro Converting Hawaii Refinery to a Terminal." Last modified January 8. <http://www.bizjournals.com/pacific/news/2013/01/08/tesoro-closing-hawaii-refinery.html>.
- Siah, Marc M., and Manfred J. Zapka. 2009. *Hawaii Bioenergy Master Plan: Distribution Infrastructure for Both Marine and Land*. Hawaii Natural Energy Institute.
- Simonpietri, Joelle, John Ashworth, and Andy Aden. 2012. "Biofuels in Context." Presentation on the Hawaii Clean Energy Initiative, Hawaii, April 11.
- Simonpietri, Joelle. 2011. "U.S. Pacific Command - Energy Security Perspective." Brief on U.S. Pacific Command energy security perspective for Hawaii, PACOM Energy Office, Hawaii, May 20.
- Sims, Bryan. 2011. "Order Placed for OriginOil Algae Extraction System." Last modified May 26. <http://www.biodieselmagazine.com/articles/7816/order-placed-for-originoils-algae-extraction-system-in-australia>.
- Solazyme, Inc. 2009. "Solazyme Overview." Last modified September 9. [http://www.calstart.org/Libraries/Industry\\_Press\\_Releases/Solazyme\\_overview\\_sheet.sflb.ashx](http://www.calstart.org/Libraries/Industry_Press_Releases/Solazyme_overview_sheet.sflb.ashx).
- Solomons, Craig Fryhle and Graham. 2002. *Organic Chemistry*. New York: John Wiley & Sons.
- Speight, James G. 2007. *The Chemistry and Technology of Petroleum*. Boca Raton, FL: CRC Press.

- Spendier, K. 2011. "Harvesting and Extraction - Lecture 11 Slides." Last modified April 5.  
<http://algalbiofuels.pbworks.com/f/Lecture+11.pdf>.
- Sperling's BestPlaces. 2013. "Cost of Living Comparison: Geismar, Louisiana - Kapolei, Hawaii." Accessed March 25.  
<http://www.bestplaces.net/col/?salary=50000&city1=77073400&city2=51530300>.
- SPX Corporation. 2013. "APV Dryer Handbook." *APV*. Accessed March 25.  
<http://www.spx.com/en/apv/downloads/manuals/>.
- State of Hawaii. 2013. "About Hawaii Energy." Accessed February 7.  
<http://energy.hawaii.gov/about>.
- . 2013. "Commission on Hawaii Resource Management." Last modified March 20.  
<http://hawaii.gov/dlnr/cwrml/>.
- . 2013. "Department of Agriculture." Accessed March 25.  
<http://hdoa.hawaii.gov/>.
- . 2013. "Department of Health Mission Statement." Accessed March 25.  
<http://hawaii.gov/health/about/mission/index.html>.
- . 2013. "Department of Health Solid and Hazardous Waste Branch." Accessed March 25.  
<http://hawaii.gov/health/environmental/waste/sw/index.html>.
- . 2012. "Commercial and Industrial Leases; Renewal; Fair Market Value." Last modified July 1.  
[http://www.capitol.hawaii.gov/session2012/Bills/HB1829\\_HD2\\_.HTM](http://www.capitol.hawaii.gov/session2012/Bills/HB1829_HD2_.HTM).
- . 2009. "Hawaii Department of Business, Economic Development and Tourism." Last modified December 17.  
[http://hawaii.gov/dbedt/welcome\\_html](http://hawaii.gov/dbedt/welcome_html).
- State of Hawaii; Department of Business, Economic Development, and Tourism. 2011. *Renewable Energy in Hawaii*. Economic Report, Research and Economic Analysis.
- Steenwyk, Jason Van. 2012. "Why is Buying Real Estate in Hawaii so Different?" Last modified April 7.  
<http://www.realestate.com/advice/hawaii-real-estate-for-sale/>.
- Stefani, Michael R. 2013. "Environmental Impact Communication State of Hawaii."

- Stein, Amanda D. 2012. "NPS Evaluates Biofuels for Fleet Power." *Navy Postgraduate School*. Monterey, CA: Naval Postgraduate School. Last modified September. [http://www.nps.edu/Images/Docs/update\\_Sept12.pdf](http://www.nps.edu/Images/Docs/update_Sept12.pdf).
- Stillwater Associates. 2013. "The Navy's Latest Mission: Cutting Fossil Fuel Consumption in Half by 2020." Accessed February 10. [http://stillwaterassociates.com/index.php?option=com\\_content&view=article&id=146:the-navys-quest-for-renewable-fuels&catid=40:white-papers&Itemid=155](http://stillwaterassociates.com/index.php?option=com_content&view=article&id=146:the-navys-quest-for-renewable-fuels&catid=40:white-papers&Itemid=155).
- Storms, Eric. 2011. "Algae Powered Navy Ship Sets Speed Record." Last modified December 11. <http://www.milpages.com/blog/8967>.
- Swartz, V. 2000. *Mechanism of Hydrodenitrogenation over Carbide and Sulfide*. M.S. Thesis, Virginia Tech.
- Systems Management College. 2001. *Systems Engineering Fundamentals*. Fort Belvoir, VA: Defense Acquisition University Press.
- Taste of the Hawaiian Range. 2013. "Hawaii Grass Fed Beef." Accessed March 25. <http://www.tasteofthehawaiianrange.com/grass-fed-101/hawaii-grass-fed-beef.html>.
- Tesoro Corporation. 2012. "Tesoro Hawaii Fact Sheet." Last modified October 1. [http://www.tsocorp.com/stellent/groups/public/documents/gt\\_contribution/001528.pdf](http://www.tsocorp.com/stellent/groups/public/documents/gt_contribution/001528.pdf).
- Transparent Technologies Private Limited. 2012. "Flash Drying Plant." Last modified October 29. <http://www.ecokleen.com/FLASH%20DRYER%20%20LITERATURE.pdf>.
- Trent, Johathan. 2012. "Offshore Membrane Enclosures for Growing Algae." NASA. Last modified March 27. [http://www.nasa.gov/centers/ames/pdf/637997main\\_omega\\_brochure.pdf](http://www.nasa.gov/centers/ames/pdf/637997main_omega_brochure.pdf).
- Trent, Jonathan. 2010. *Offshore Membrane Enclosures for Growing Algae (OMEGA): A System for Biofuel Production, Wastewater Treatment, and CO2 Sequestration*. NASA.
- Trent, Jonathan. 2010. *OMEGA for the Future of Biofuels*. Technical Report, NASA, 94.
- Triantaphyllou, Evangelos, and Stuart Mann. 1995. "Using The Analytic Hierarchy Process For Decision Making." *Intentional of Industrial Engineering: Applications and Practice 2*: 35-44.

- U.S. Department of Defense. 2013. "About the Department of Defense." Accessed March 25.  
<http://www.defense.gov/about/#mission>.
- U.S. Department of Energy. 2013. "Biodiesel Production and Blending Tax Credit." Last modified January 14.  
<http://www.afdc.energy.gov/laws/law/KY/5831>.
- . 2013. "U.S. Department of Energy Mission." Accessed February 7.  
<http://energy.gov/mission>.
- . 2012. "Hydrogen Production." Last modified November 20.  
[http://www1.eere.energy.gov/hydrogenandfuelcells/production/natural\\_gas.html](http://www1.eere.energy.gov/hydrogenandfuelcells/production/natural_gas.html).
- . 2010. *National Algal Biofuels Technology Roadmap*. Washington, DC: Office of the Biomass Program.
- . 2002. "Hydrogen Cost and Worldwide Production." Last modified February 25.  
[http://www1.eere.energy.gov/vehiclesandfuels/facts/favorites/fcvt\\_fotw205.html](http://www1.eere.energy.gov/vehiclesandfuels/facts/favorites/fcvt_fotw205.html).
- U.S. Department of the Interior. 2006. "Final Boise/Payette Water Storage Assessment Report."
- U.S. Department of Transportation Federal Highway Administration. 2013. "National Environmental Protection Agency (NEPA) Documentation Environmental Impact Statement (EIS)." Accessed February 11.  
<http://www.environment.fhwa.dot.gov/projdev/docueis.asp>.
- U.S. Energy Information Administration. 2013. "Hawaii Price of Natural Gas Sold to Commercial Consumers." Last modified January 31.  
<http://www.eia.gov/dnav/ng/hist/n3020hi3m.htm>.
- . 2012. *Annual Energy Review 2011*. Washington, DC: U.S. Department of Energy.
- . 2008. "The Impact of Increased Use of Hydrogen on Petroleum Consumption and Carbon Dioxide Emissions." Accessed September 12.  
<http://www.eia.gov/oiaf/servicerpt/hydro/appendixc.html>.
- . 2006. "Manufacturing Energy Consumption Survey (MECS)." Accessed November 15.  
<http://www.eia.gov/consumption/manufacturing/data/2006/>.
- . 2004. "Petroleum Industry Analysis Brief." Last modified January 28.  
<http://www.eia.gov/emeu/mecs/iab98/petroleum/index.html>.

- U.S. Environmental Protection Agency. 2013. "40 CFR 261.32 - Hazardous Wastes From Specific Sources." Last modified March 21.  
<http://www.ecfr.gov>.
- . 2013. "40 CFR 268.40 - Applicability of Treatment Standards." Last Modified 21.  
<http://www.ecfr.gov>.
- . 2013. "About EPA: Our Mission and What We Do." Last modified March 13.  
<http://www.epa.gov/aboutepa/whatwedo.html>.
- . 2013. "Renewable Fuel Standard (RFS)." Accessed March 25.  
<http://www.epa.gov/otaq/fuels/renewablefuels/index.htm>.
- . 2013. "Summary of the Clean Water Act." Last modified February 24.  
<http://www.epa.gov/regulations/laws/cwa.html>.
- . 2012. "Chevron Products Company - Hawaii Refinery." Last modified October 19.  
[http://data.rtknet.org/tri/tri.php?reptype=f&database=tri&facility\\_name=&facility\\_id=96707CHVRN91480&city=&state=&reporting\\_year=2007&first\\_year\\_range=&last\\_year\\_range=&detail=3&dbtype=C&sortp=D&datatype=T&email=&subj=](http://data.rtknet.org/tri/tri.php?reptype=f&database=tri&facility_name=&facility_id=96707CHVRN91480&city=&state=&reporting_year=2007&first_year_range=&last_year_range=&detail=3&dbtype=C&sortp=D&datatype=T&email=&subj=)
- . 2012. "Drinking Water Analytical Methods." Last modified June 12.  
<http://water.epa.gov/scitech/drinkingwater/labcert/analyticalmethods.cfm>.
- . 2012. "Water & Energy Efficiency by Sectors." Last modified December 15.  
<http://www.epa.gov/region9/waterinfrastructure/oilrefineries.html>.
- . 2011. "EPA and Biofuels: A Primer on EPA's Authorities, Responsibilities, and Research." Last modified March 2.  
[http://www.epa.gov/sustainability/docs/biofuels\\_primer\\_3-2-11.pdf](http://www.epa.gov/sustainability/docs/biofuels_primer_3-2-11.pdf).
- . 2010. *Renewable Fuel Standard Program (RFS2) Regulatory Impact Analysis*. Assessment and Standards Division.
- . 2008. *Environmental Laws Applicable to Construction and Operation of Biodiesel Production Facilities*. Washington, DC: Biofuels Working Group.
- . 2001. *Land Disposal Restrictions: Summary of Requirements*. Offices of Solid Waste and Emergency Response & Enforcement and Compliances Assurance.
- U.S. Federal Emergency Management Agency. 2012. "U.S. FEMA Emergency Response Plan." Accessed November 13.  
<http://www.ready.gov/business/implementation/emergency>.
- U.S. Pacific Command. 2013. "U.S. Pacific Command Strategic Guidance." Accessed January 7.  
<http://www.pacom.mil/about-uspacom/strategic-guidance.shtml>.

- United States Navy. 2013. "Chief of Naval Operations Energy and Environmental Readiness Division." Accessed March 25.  
<http://www.navy.mil/local/n45/>.
- University of Hawai'i Economic Research Organization. 2013. "Breaking Down The Tesoro Refinery Closure - Part 1." Last modified January 29.  
<http://www.uhero.hawaii.edu/news/view/206>.
- University of Hawai'i. 2013. "Hawaii Natural Energy Institute." Accessed March 25.  
<http://www.hnei.hawaii.edu/>.
- . 2013. "Water Resource Research Center." Accessed March 25.  
<http://www.wrrc.hawaii.edu/>.
- UOP LLC, A Honeywell Company. 2013. *Email between Honeywell and USPACOM*. January 15.
- . 2012. "Honeywell Green Jet Fuel powers Gulfstream Flights to NBAA." Last modified October 29.  
<http://www.uop.com/honeywell-green-jet-fuel-powers-gulfstream-flights-nbaa/>.
- . 2011. "Refinery Hydrogen." Accessed January 20, 2013.  
<http://www.uop.com/processing-solutions/refining/hydrogen-management/>.
- Van Gerpen, Jon H. 2008. *Biodiesel Economics*. Billings: University of Idaho.
- Vardon, Derek, B.K. Sharma, John Scott, Guo Yu, Zhichao Wang, Lance Shideman, Yuanhui Zhang, and Timothy Strathmann. 2011. "Chemical Properties of Biocrude Oil from the Hydrothermal Liquefaction of Spirulina Algae, Swine Manure, and Digested Anaerobic Sludge." *Bioresource Technology* 102: 8295-8303.
- Viets, John W., Narasimhan Sundaram, Bal K. Kaul, and David L. Stern. 2012. Hydrocracking of Heavy Feedstocks with Improved Hydrogen Management. United States of America Patent 2011/0100873. May 29.
- Virginia Community College. 2013. "Lesson 4: Coagulation and Flocculation." Accessed February 18.  
[http://water.me.vccs.edu/courses/ENV110/Lesson4\\_print.htm](http://water.me.vccs.edu/courses/ENV110/Lesson4_print.htm).
- Wang, Xianhua, Kai Luo, Hanping Chen, Jingai Shao, and Haiping Yang. 2008. "The Influence of Microwave Drying on Biomass Pyrolysis." *American Chemical Society* 22: 67-74
- Waste Management. 2007. "Keeping Hawaii Clean." Accessed March 25, 2013.  
<http://www.keepinghawaiiiclean.com/>.

- Water Conservation Implementation Task Force. 2004. *Report 362: Water Conservation Best Management Practices Guide*. Austin, TX: Texas Water Development Board. Accessed March 8, 2013.  
<http://www.twdb.state.tx.us/conservation/BMPs/Ag/doc/5.2.pdf>.
- Wen, Zhiyou, and Michael B. Johnson. 2013. "Microalgae as a Feedstock for Biofuel Production." Accessed March 25.  
<http://pubs.ext.vt.edu/442/442-886/442-886.html>.
- Wilcove, David S., David Rothstein, Jason Dubow, Ali Phillips, and Elizabeth Losos. 1998. "Quantifying threats to imperiled species in the United States." *BioScience* 48: 607-616.
- Wildschut, Jelle, Farchad H. Mahfud, Robbie H. Venderbosch, and Hero J. Heeres. 2009. "Hydrotreatment of Fast Pyrolysis Oil Using Heterogeneous Noble-Metal Catalysts." *Industrial & Engineering Chemistry Research* 48: 10324-10334.
- World Bank Group. 1998. *Pollution Prevention and Abatement Handbook*. World Bank Group.
- Worley, Matt. 2011. "Biomass Drying Technology Update." *BioPro Expo and Marketplace*. Harris Group Inc.
- Wu, May, and Yiwen Chiu. 2011. *Consumptive Water Use in the Production of Ethanol and Petroleum Gasoline - 2011 Update*. Chicago: Argonne National Laboratory.
- Xebec Adsorption Inc. 2013. "Industrial Hydrogen Applications." Accessed January 20.  
<http://www.xebecinc.com/applications-industrial-hydrogen.php>.
- Xu, Yufo, Xianguo Hu, Wendong Li and Yinyan Shi. 2011. *Preparation and Characterization of Bio-Oil from Biomass*. Shanghai, China: InTech.
- Zeeco. 2011. *Sulfur Recovery Unit Combustion Equipment*. Brochure, Zeeco Inc.
- Zemke, Pete, Byard Wood, and Dan Dye. 2008. "Technoeconomic Analysis of Algal Photobioreactor for Oil Production." NREL-AFOSR Joint Workshop on Algal Oil for Jet Fuel Production. Sustainable Energy Research Center, Utah State University.

THIS PAGE INTENTIONALLY LEFT BLANK

## INITIAL DISTRIBUTION LIST

1. Defense Technical Information Center  
Ft. Belvoir, Virginia
2. Dudley Knox Library  
Naval Postgraduate School  
Monterey, California
3. George Ka'iliwai  
Resources Assessment Directorate  
U.S. Pacific Command  
Camp H.M. Smith, Hawaii
4. Joelle Simonpietri  
Resources Assessment Directorate  
U.S. Pacific Command  
Camp H.M. Smith, Hawaii