

In-service Corrosion Issues in Sustainment of Naval Aircraft



By: Rick Mendoza

NAVAIR North Island Advanced Structures Design Group

28 August 2012



Report Documentation Page

Form Approved
OMB No. 0704-0188

Public reporting burden for the collection of information is estimated to average 1 hour per response, including the time for reviewing instructions, searching existing data sources, gathering and maintaining the data needed, and completing and reviewing the collection of information. Send comments regarding this burden estimate or any other aspect of this collection of information, including suggestions for reducing this burden, to Washington Headquarters Services, Directorate for Information Operations and Reports, 1215 Jefferson Davis Highway, Suite 1204, Arlington VA 22202-4302. Respondents should be aware that notwithstanding any other provision of law, no person shall be subject to a penalty for failing to comply with a collection of information if it does not display a currently valid OMB control number.

1. REPORT DATE 28 AUG 2012	2. REPORT TYPE	3. DATES COVERED 00-00-2012 to 00-00-2012			
4. TITLE AND SUBTITLE In-service Corrosion Issues in Sustainment of Naval Aircraft		5a. CONTRACT NUMBER			
		5b. GRANT NUMBER			
		5c. PROGRAM ELEMENT NUMBER			
6. AUTHOR(S)		5d. PROJECT NUMBER			
		5e. TASK NUMBER			
		5f. WORK UNIT NUMBER			
7. PERFORMING ORGANIZATION NAME(S) AND ADDRESS(ES) NAVAIR, North Island Advanced Structures Design Group, San Diego, CA, 92135		8. PERFORMING ORGANIZATION REPORT NUMBER			
9. SPONSORING/MONITORING AGENCY NAME(S) AND ADDRESS(ES)		10. SPONSOR/MONITOR'S ACRONYM(S)			
		11. SPONSOR/MONITOR'S REPORT NUMBER(S)			
12. DISTRIBUTION/AVAILABILITY STATEMENT Approved for public release; distribution unlimited					
13. SUPPLEMENTARY NOTES Presented at the ASETSDefense 2012: Workshop on Sustainable Surface Engineering for Aerospace and Defense August 27-30, 2012, San Diego, CA					
14. ABSTRACT					
15. SUBJECT TERMS					
16. SECURITY CLASSIFICATION OF:			17. LIMITATION OF ABSTRACT Same as Report (SAR)	18. NUMBER OF PAGES 50	19a. NAME OF RESPONSIBLE PERSON
a. REPORT unclassified	b. ABSTRACT unclassified	c. THIS PAGE unclassified			

Synopsis

- **Corrosion Issues**

- Dorsal Longeron Scallop corrosion.
- Inner Wing Corrosion.
- Outer Wing Corrosion.
- Fuel cell Floor Corrosion.
- Y395 Lug Corrosion.



Dorsal Longeron Doors



Dorsal Longeron



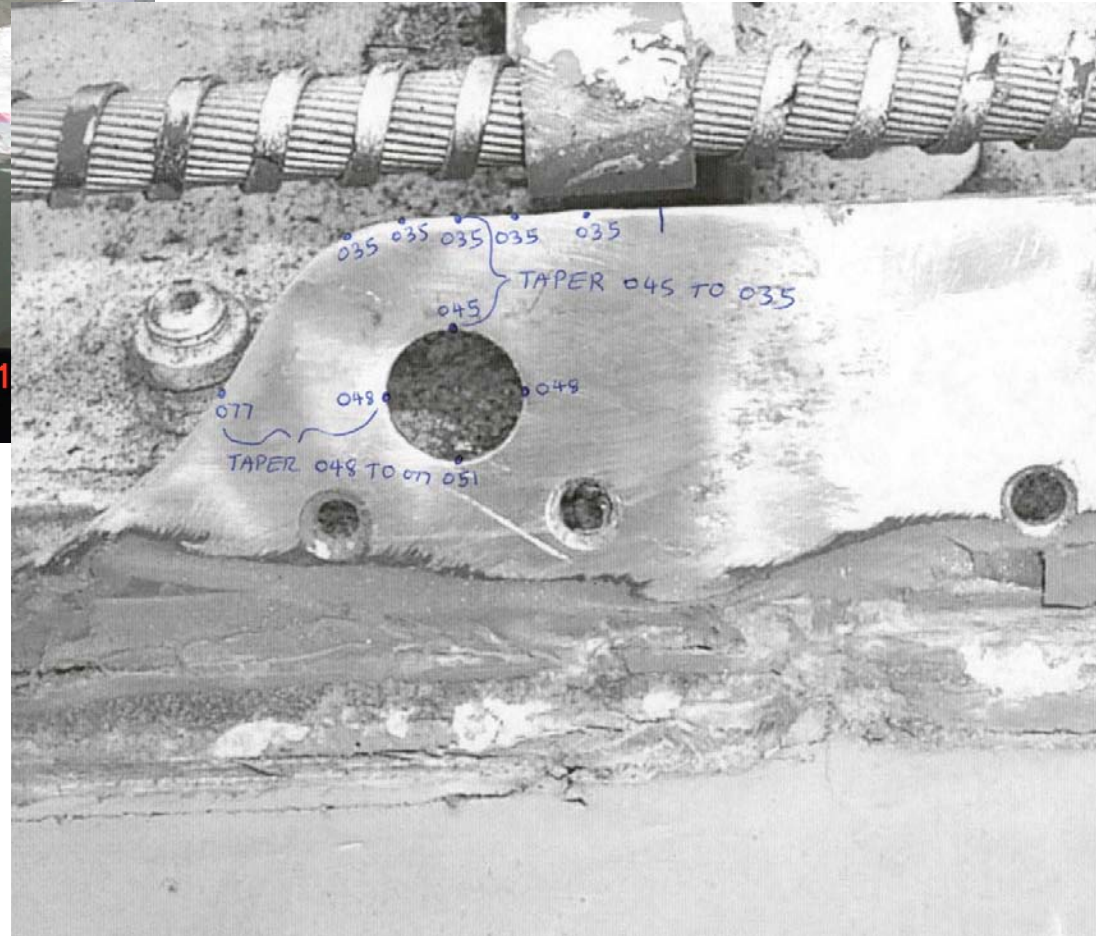





INNER WING STRUCTURE

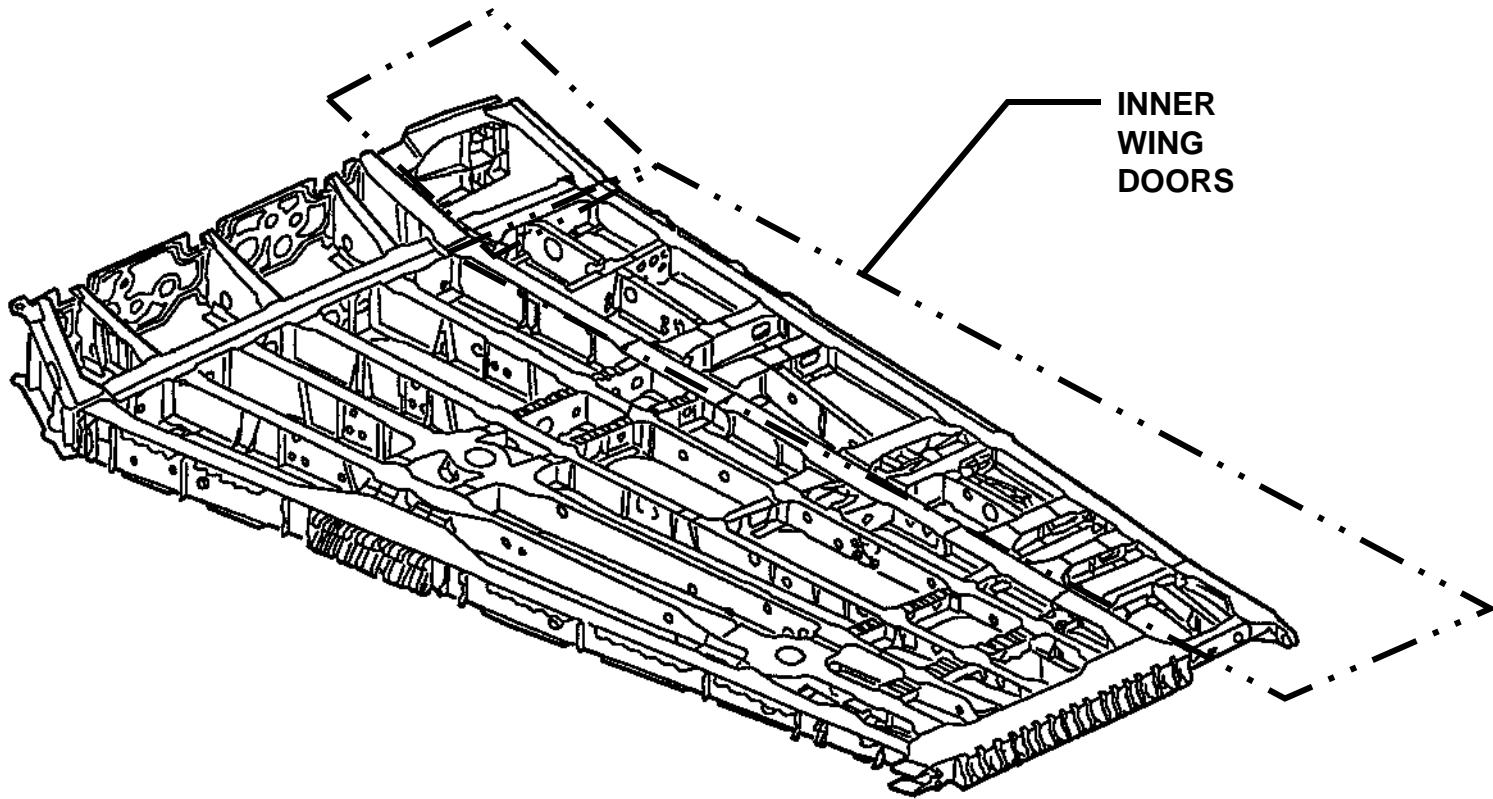

IWP DOOR SUBSTRUCTURE

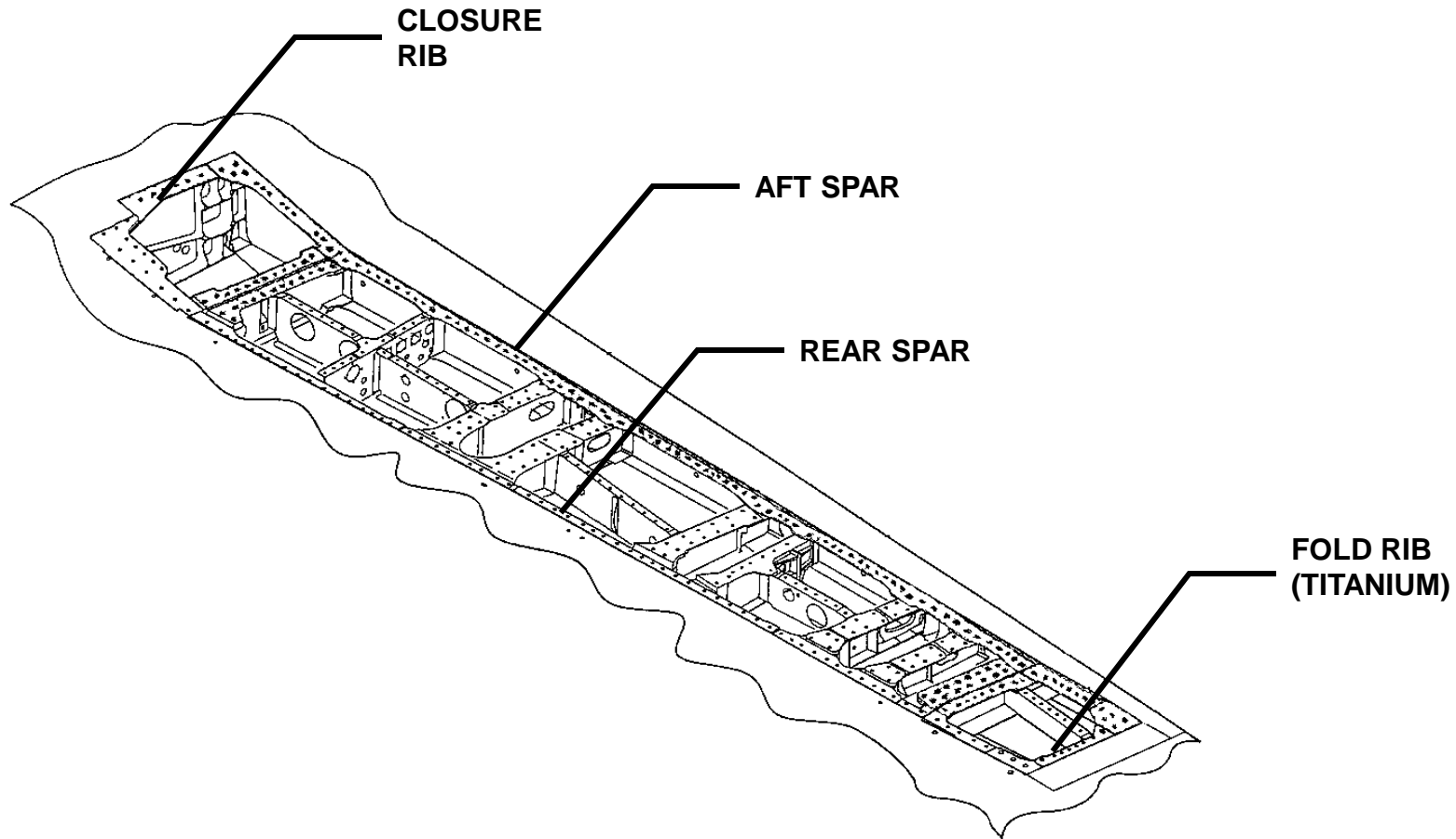

DOOR 78/79/143/82 SUBSTRUCTURE







IWP AFT SPAR/FOLD RIB INTERFACE

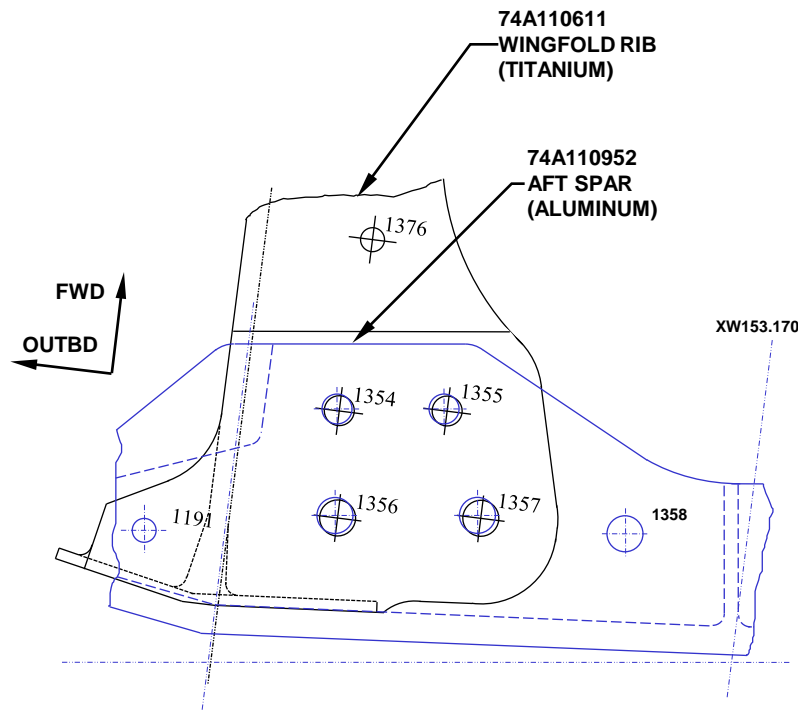

VIEW LOOKING DOWN AT AFT SPAR UPPER FLANGE

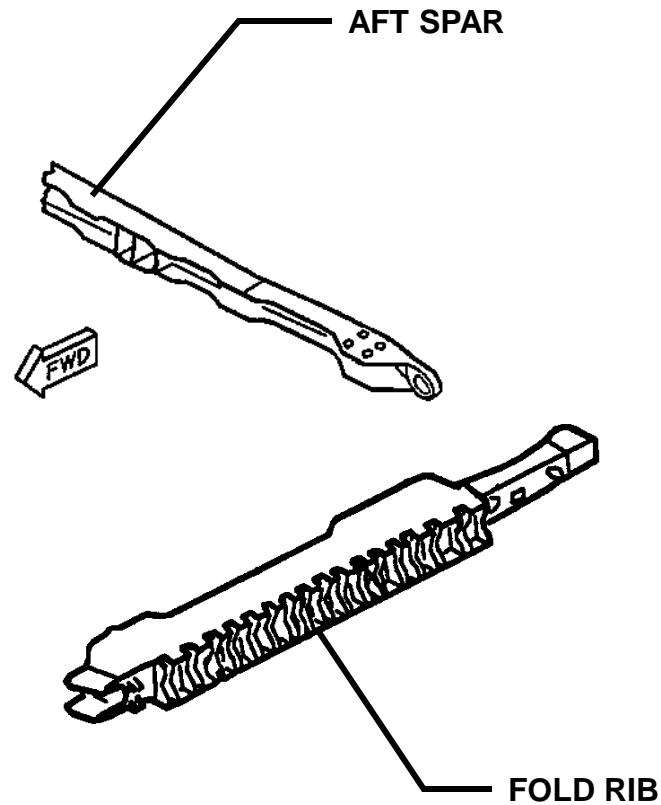

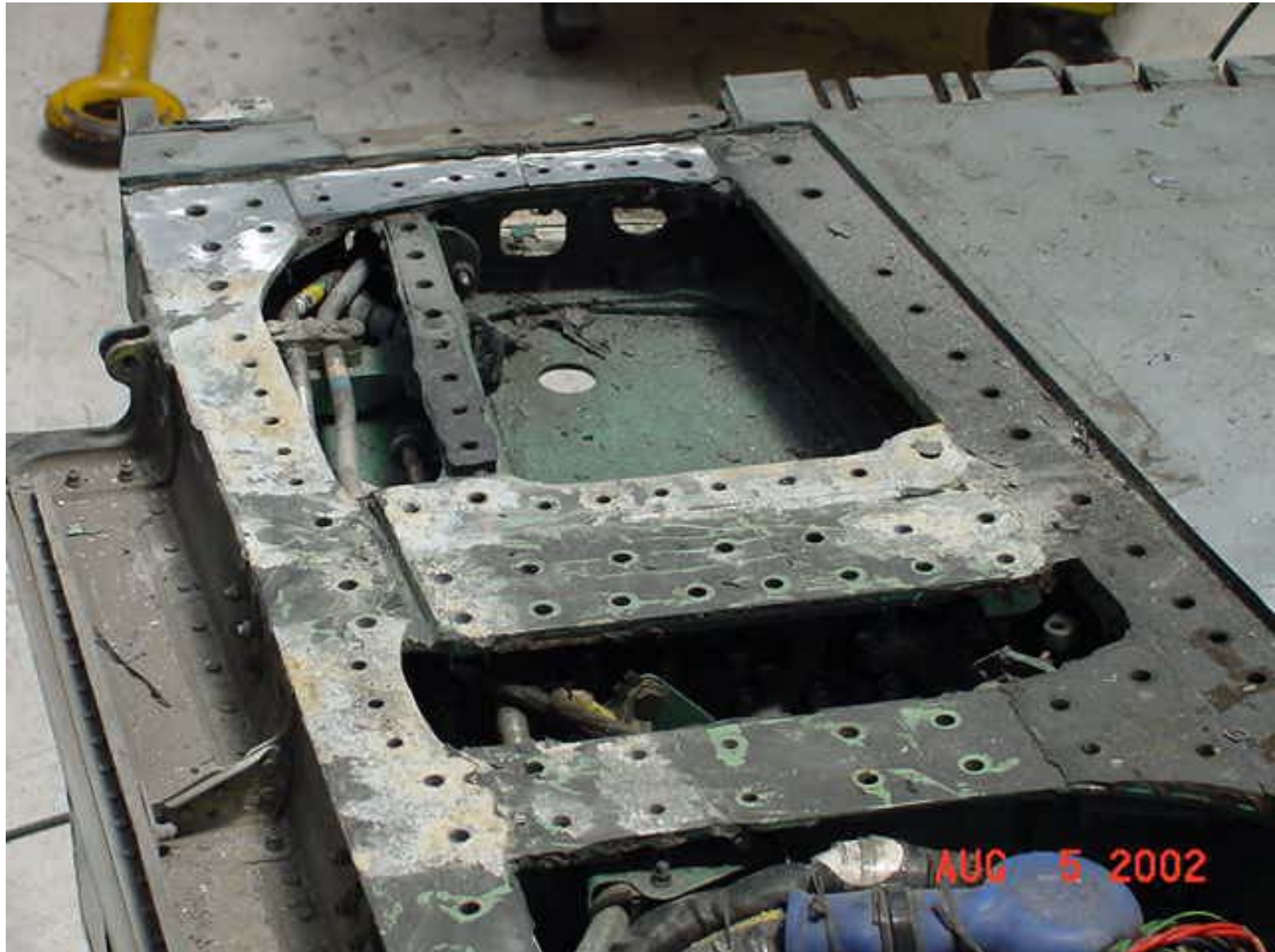





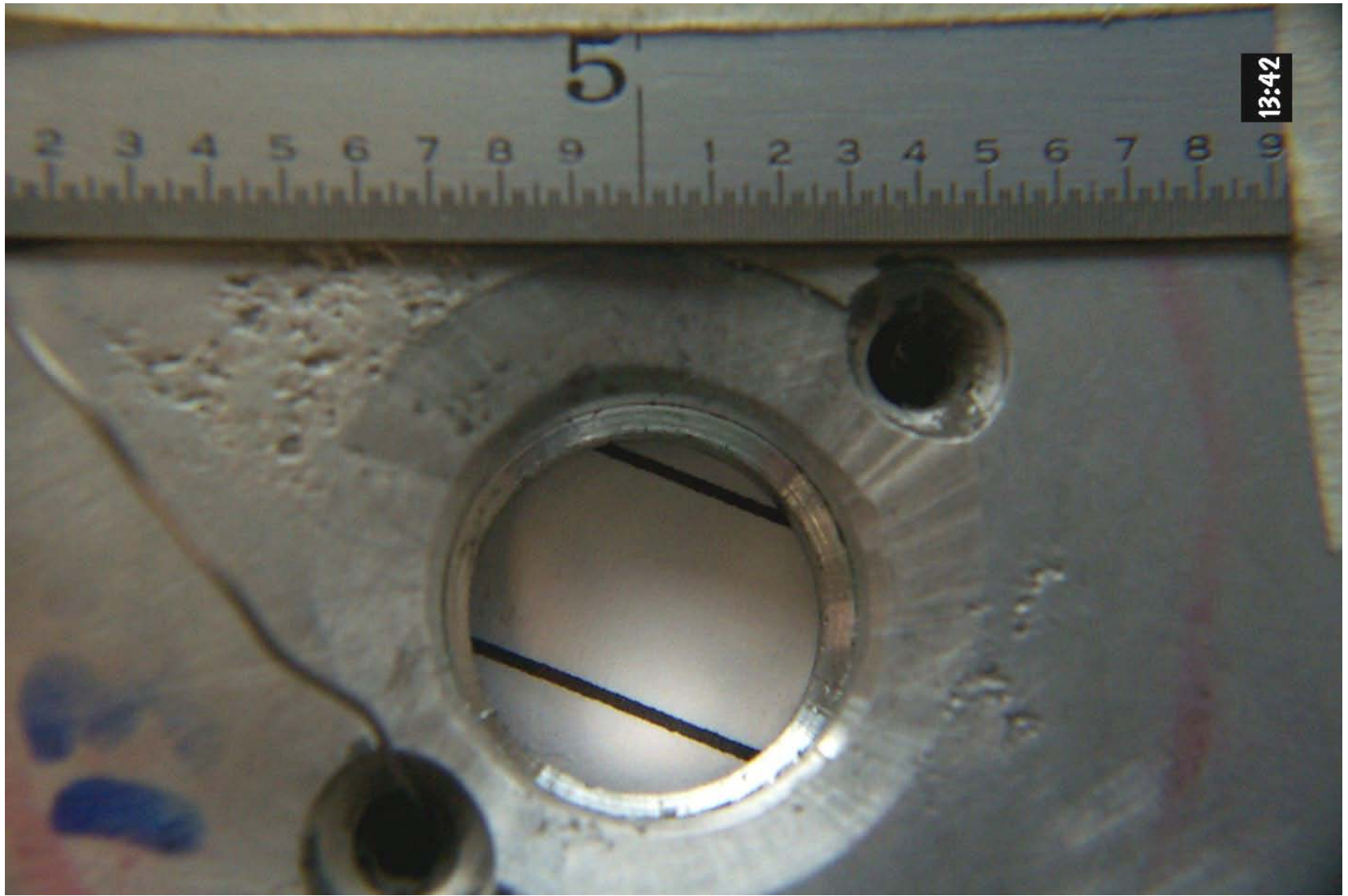

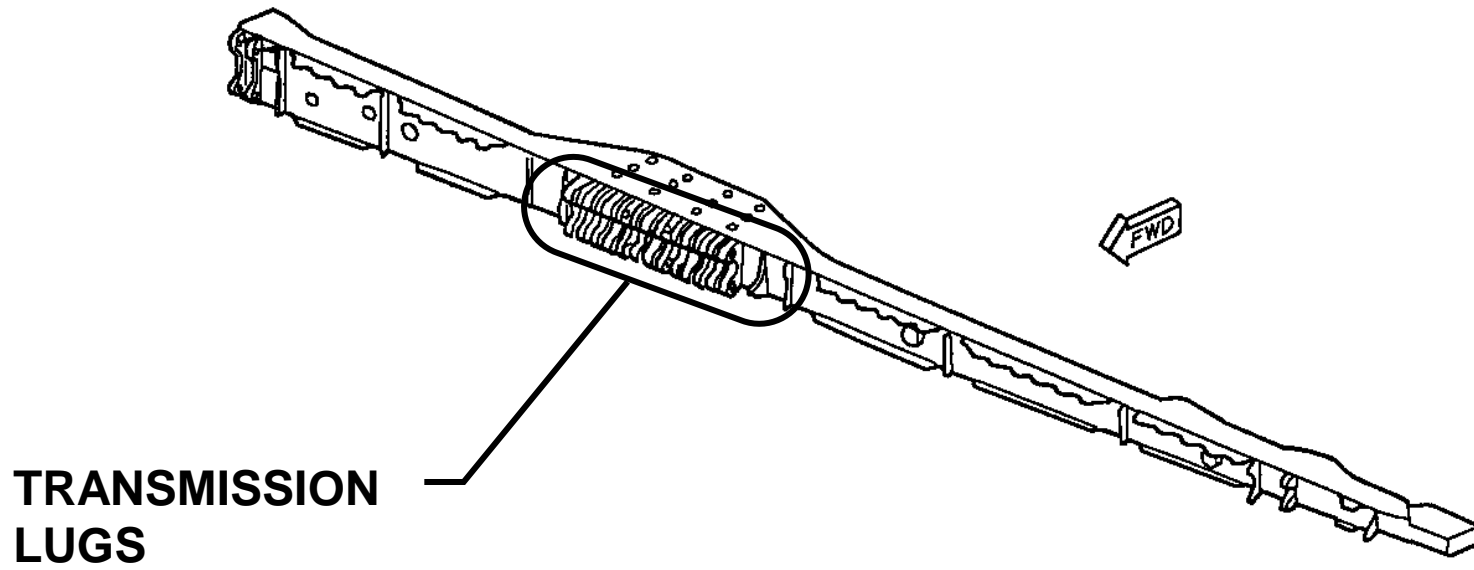

**TRANSMISSION
LUGS**



**CORROSION
PITTING**

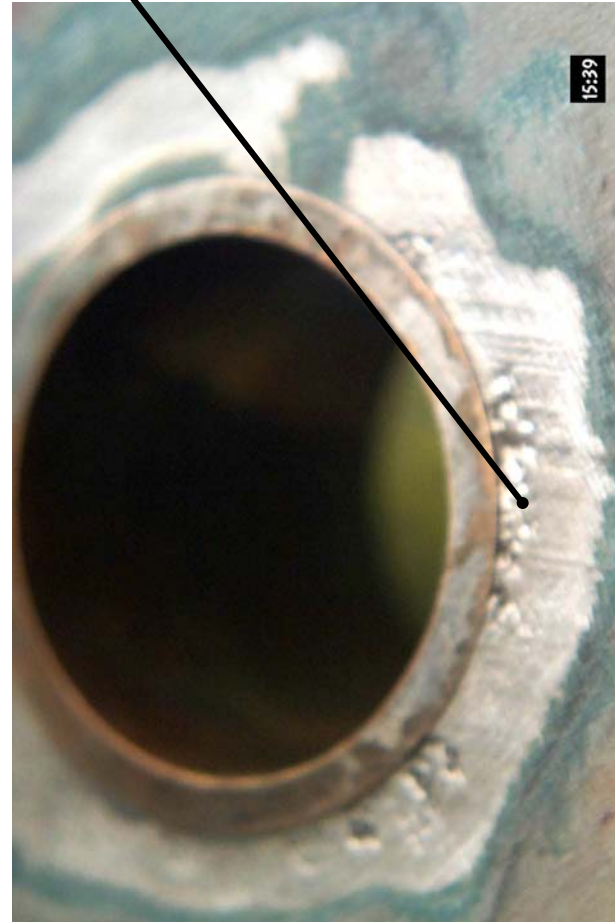
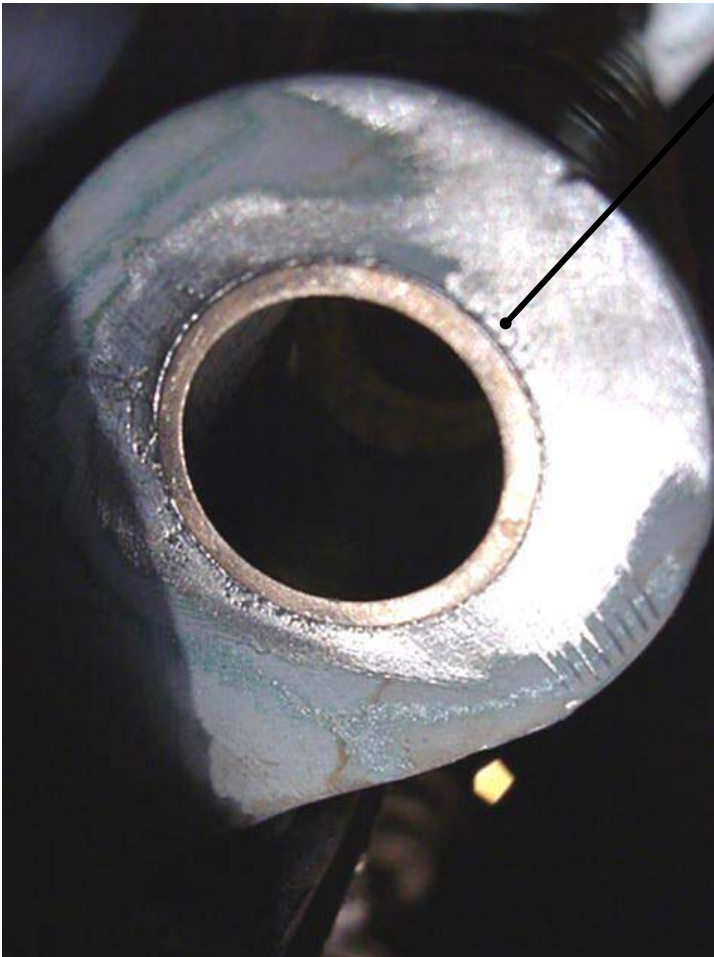

OUTER WING STRUCTURE

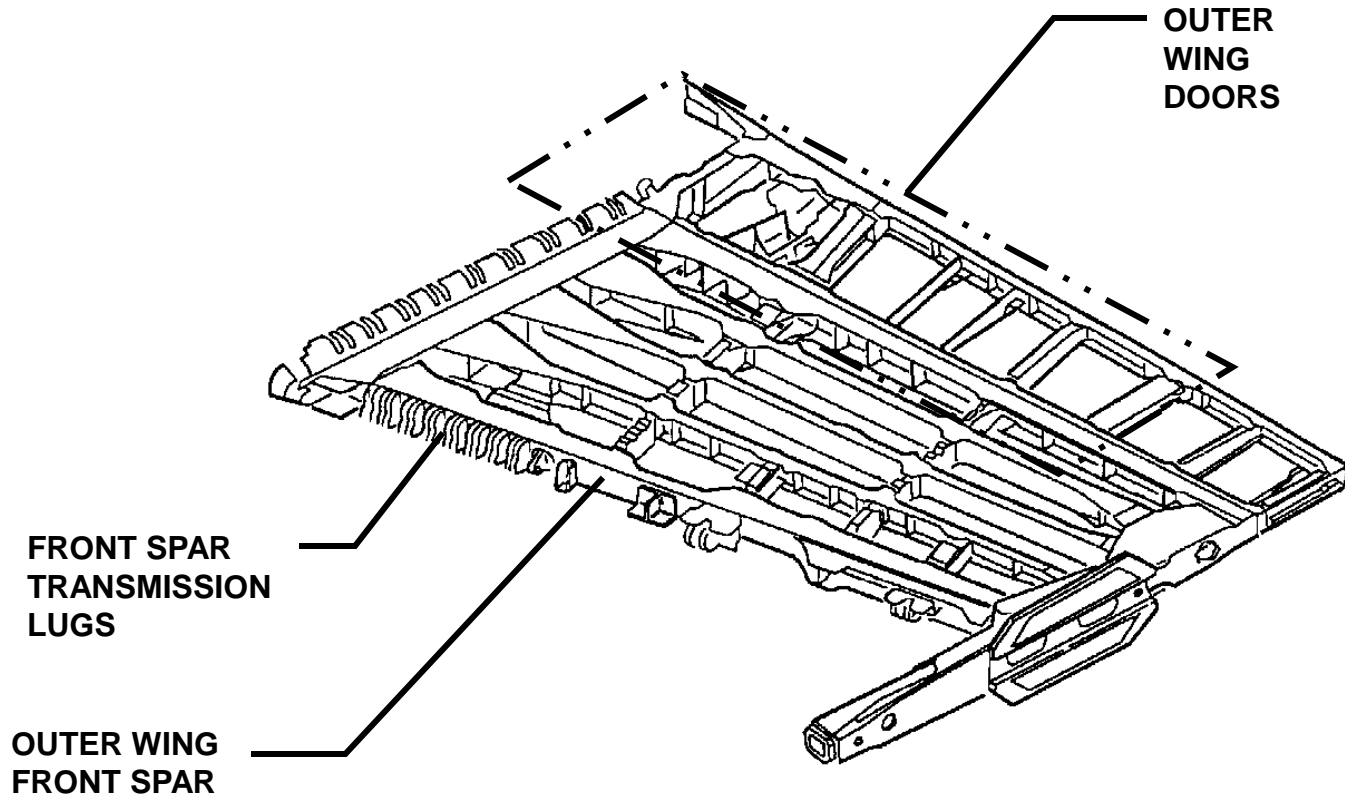

OWP DOOR 83/84 SUBSTRUCTURE

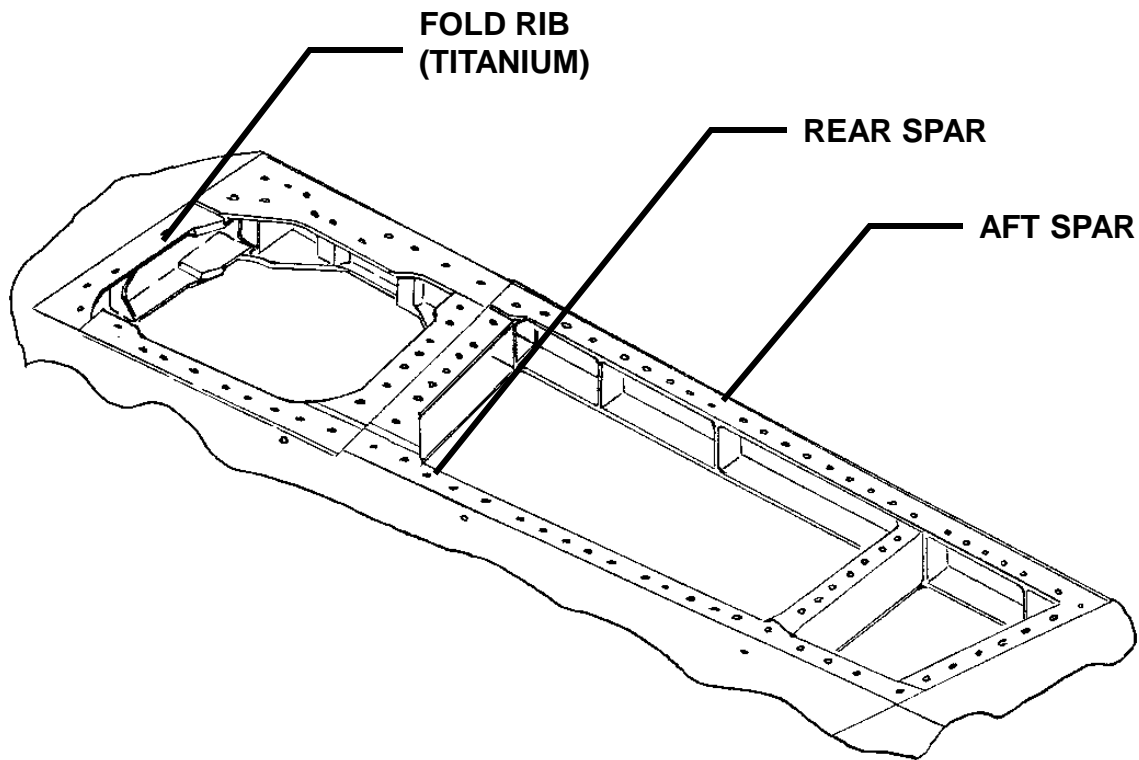

DOOR 84/84 SUBSTRUCTURE



OWP AFT SPAR AILERON INBOARD & OUTBOARD HINGES

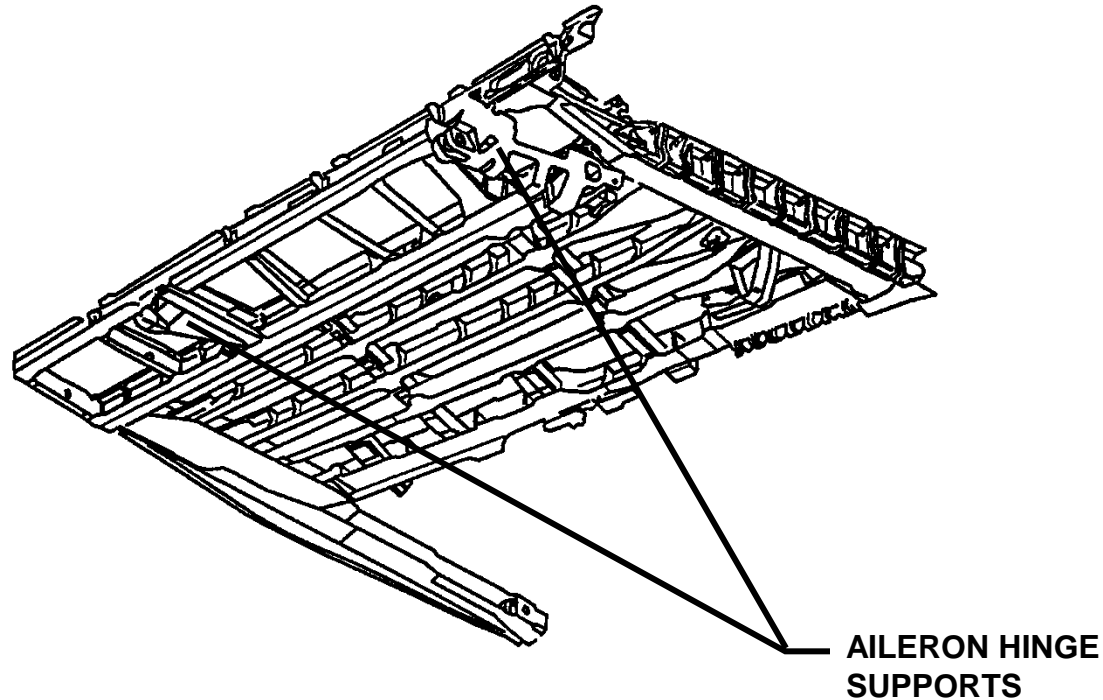

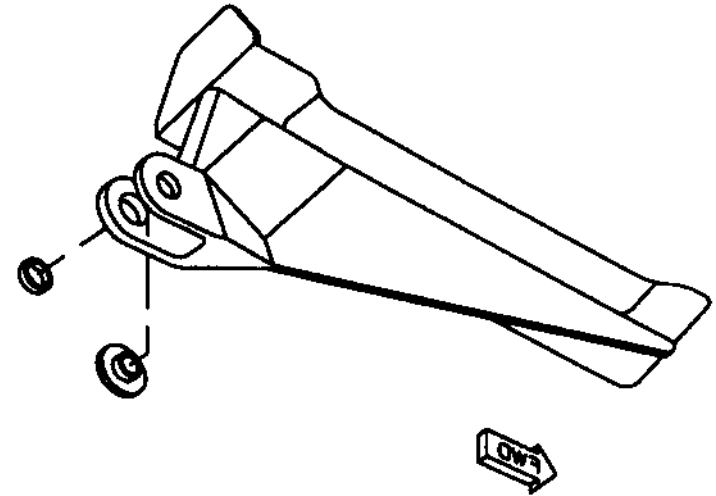
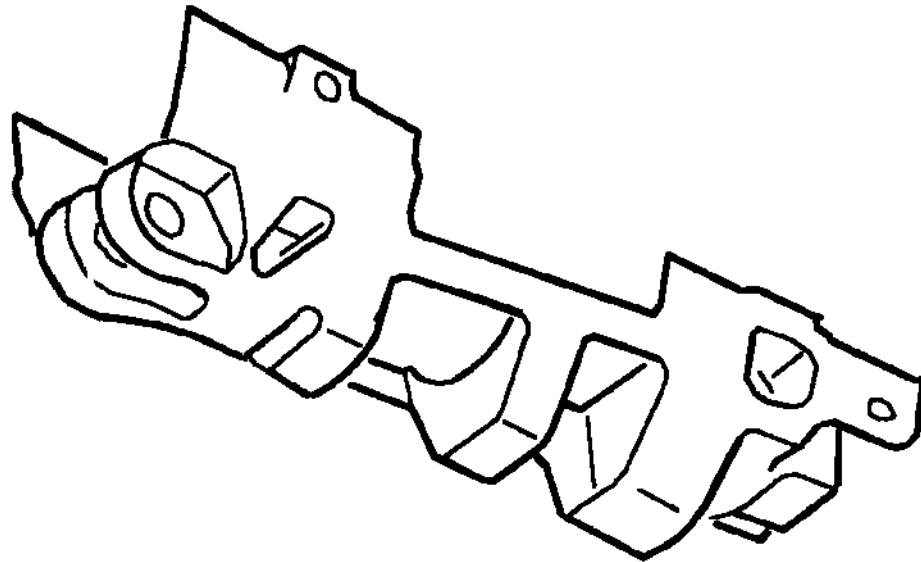



CORROSION PITTING



OWP FRONT SPAR

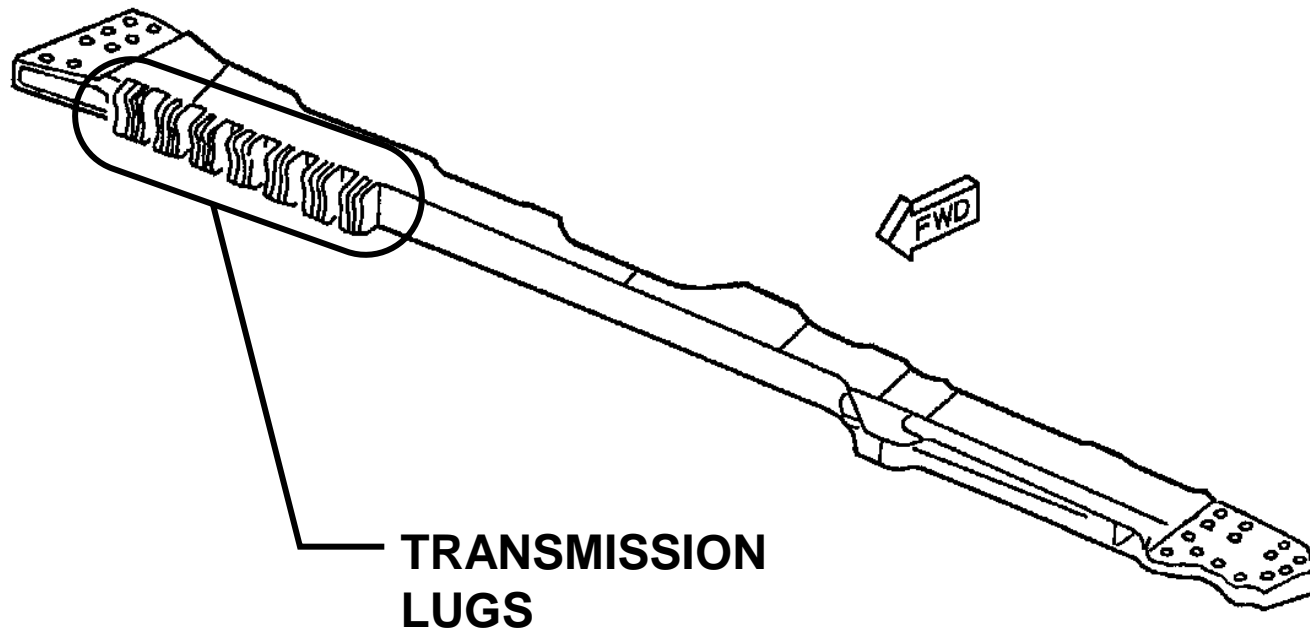





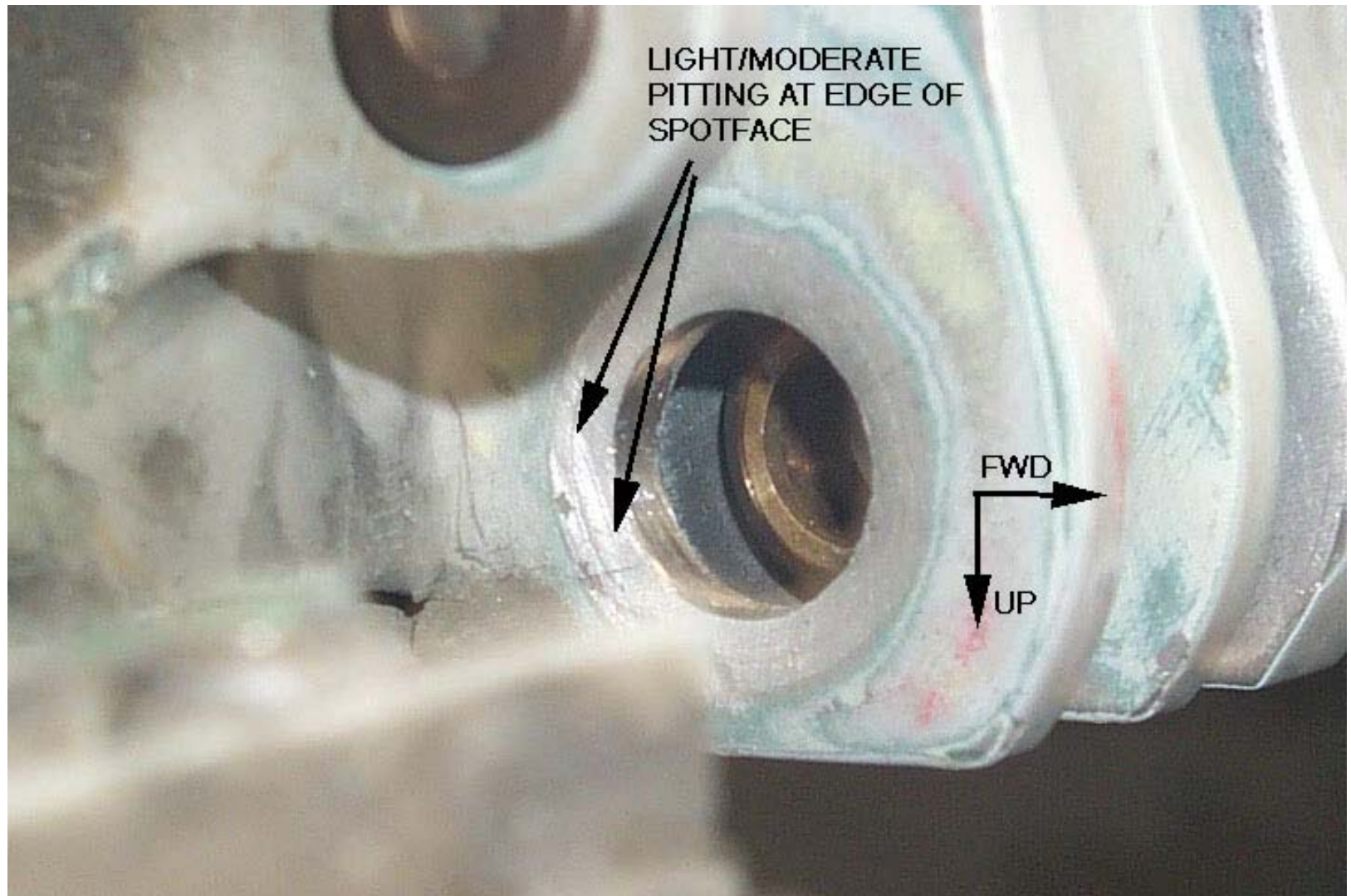

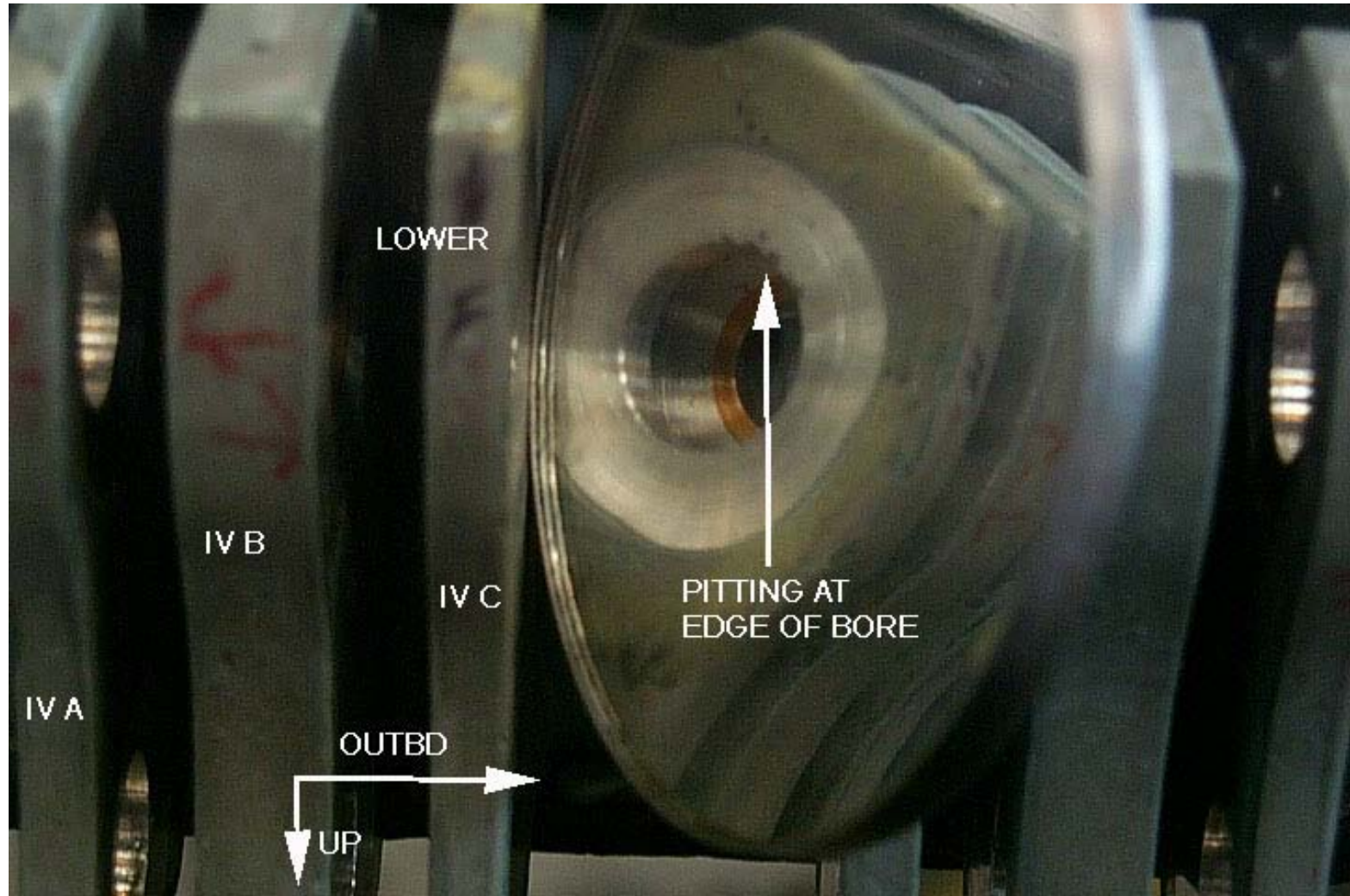

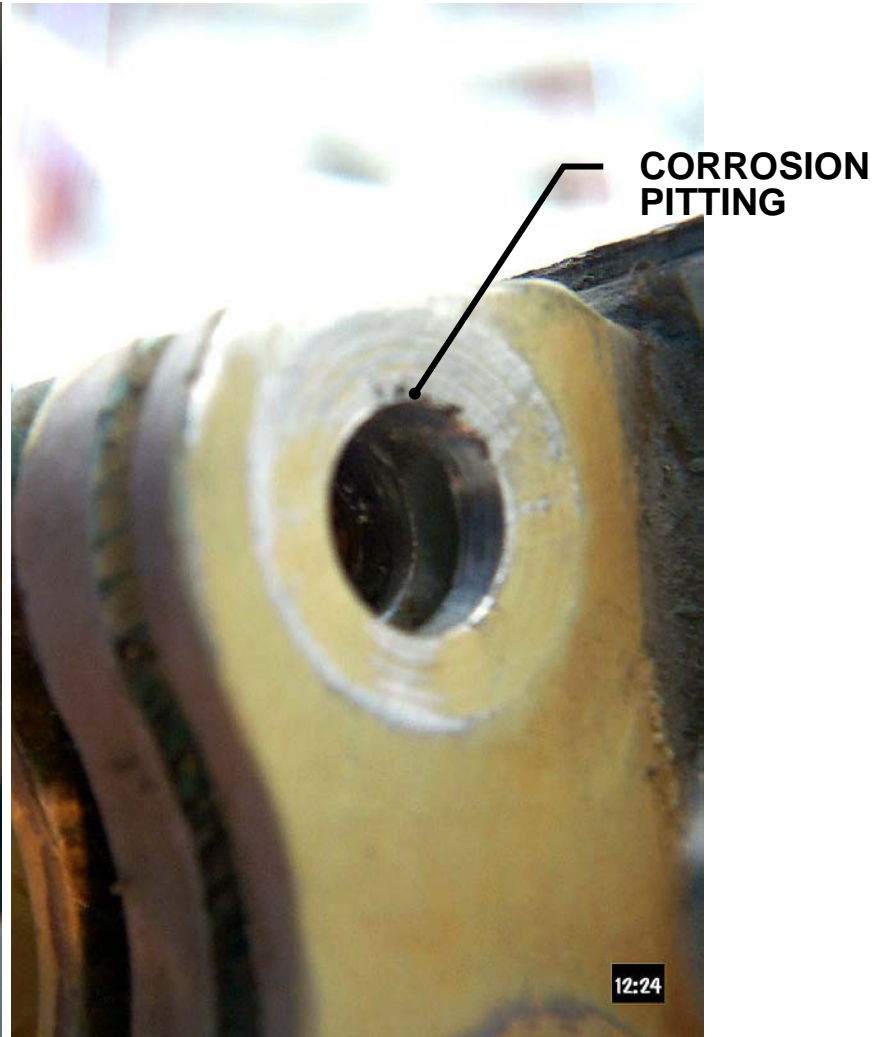
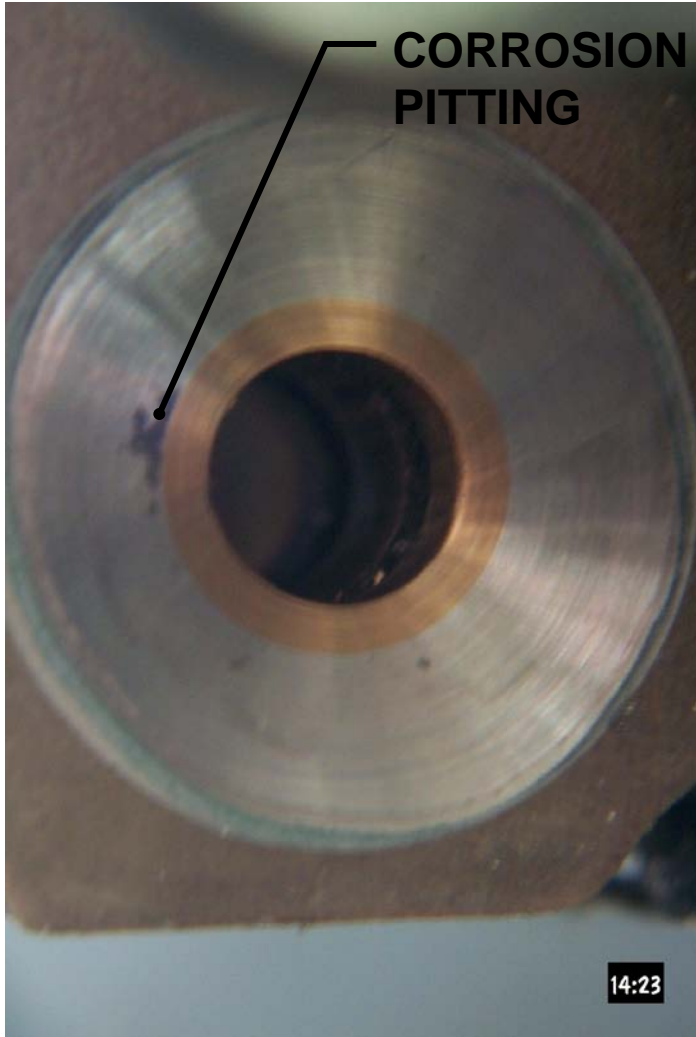

#2 AND #3 FUEL CELLS

F/A-18A

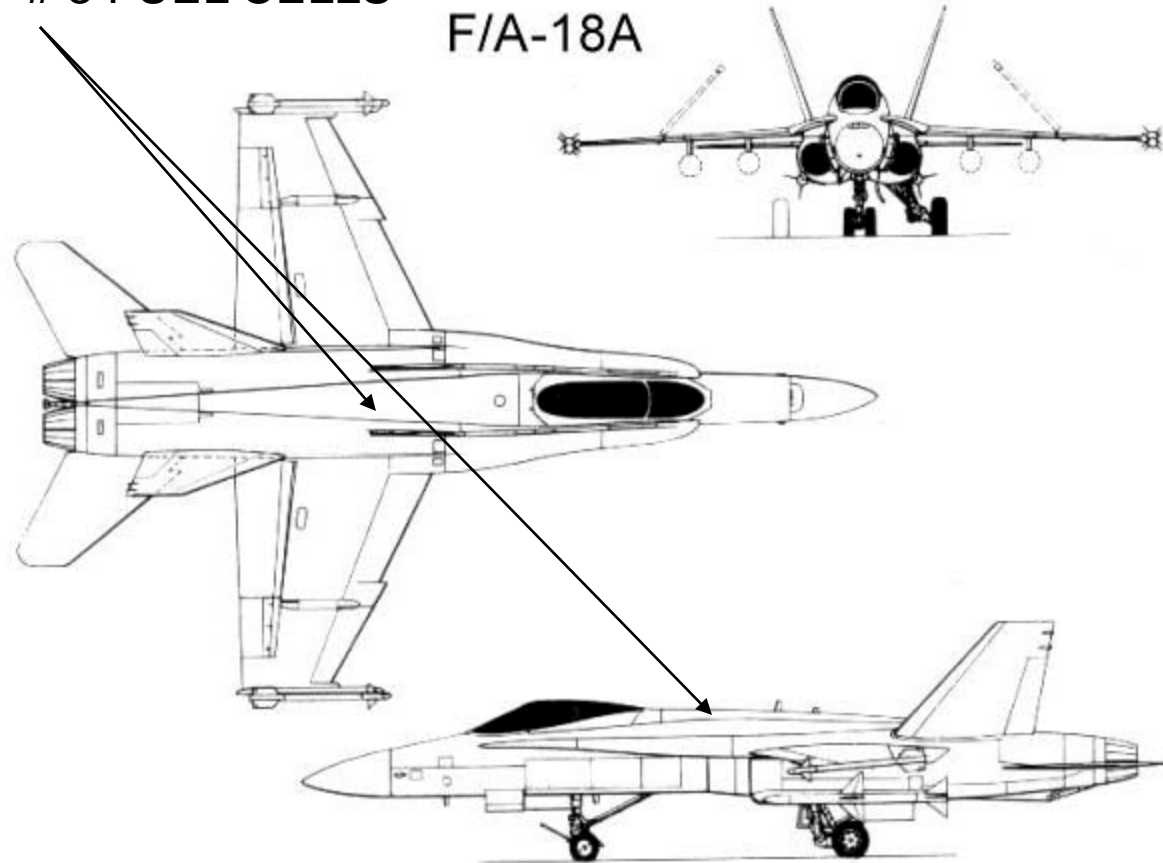

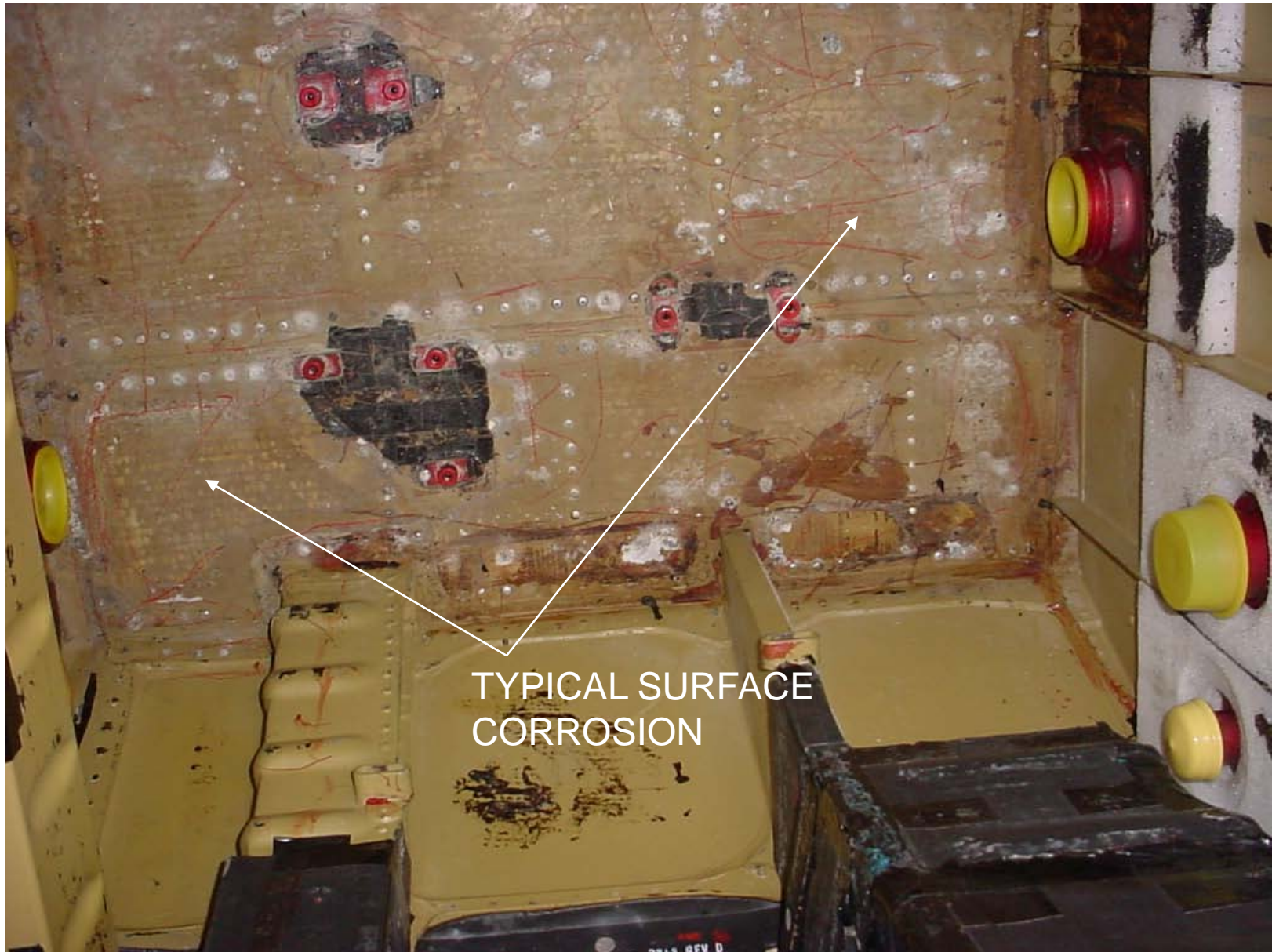

TYPICAL SURFACE
CORROSION







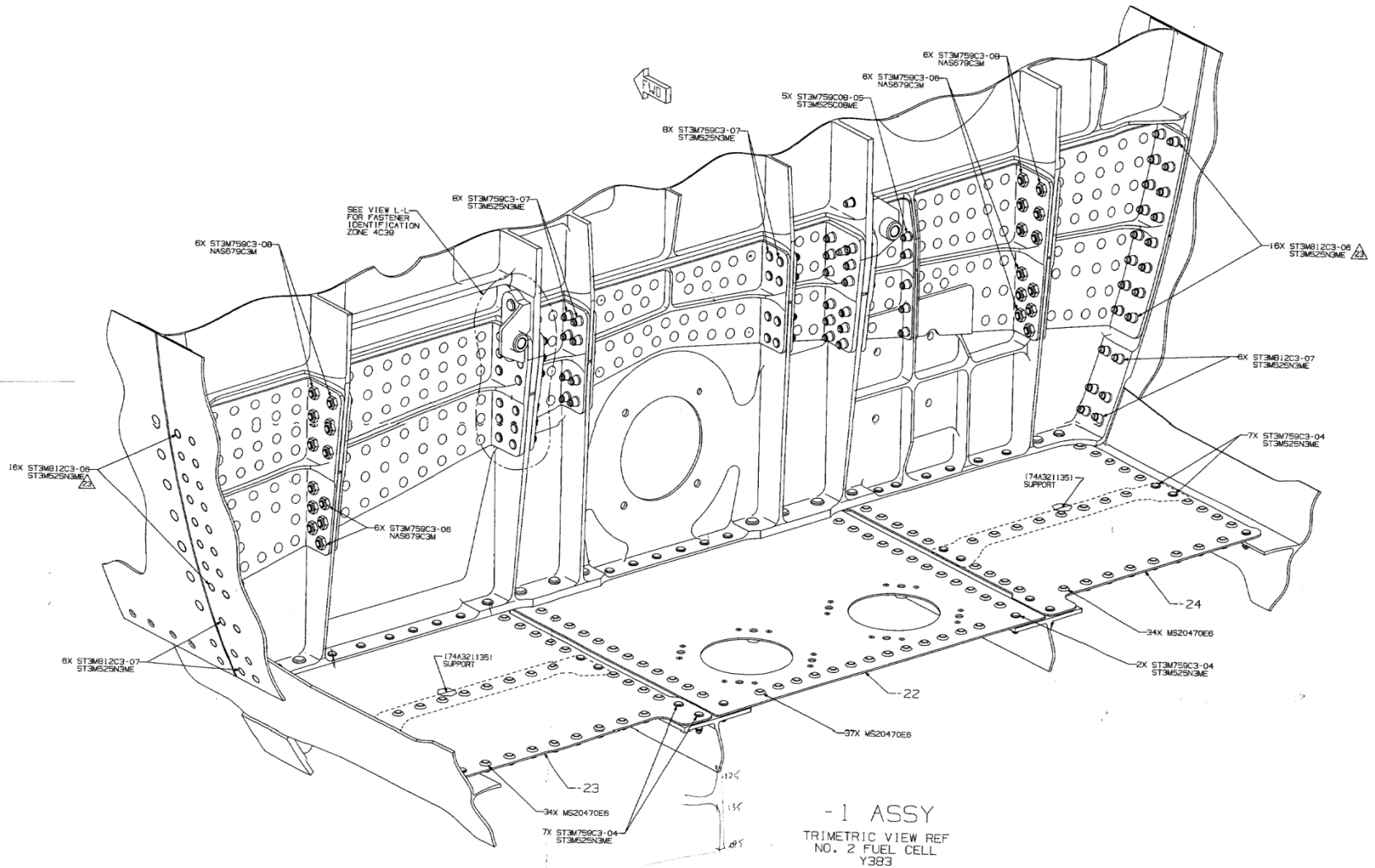

WING-FUSELAGE ATTACH BULKHEADS

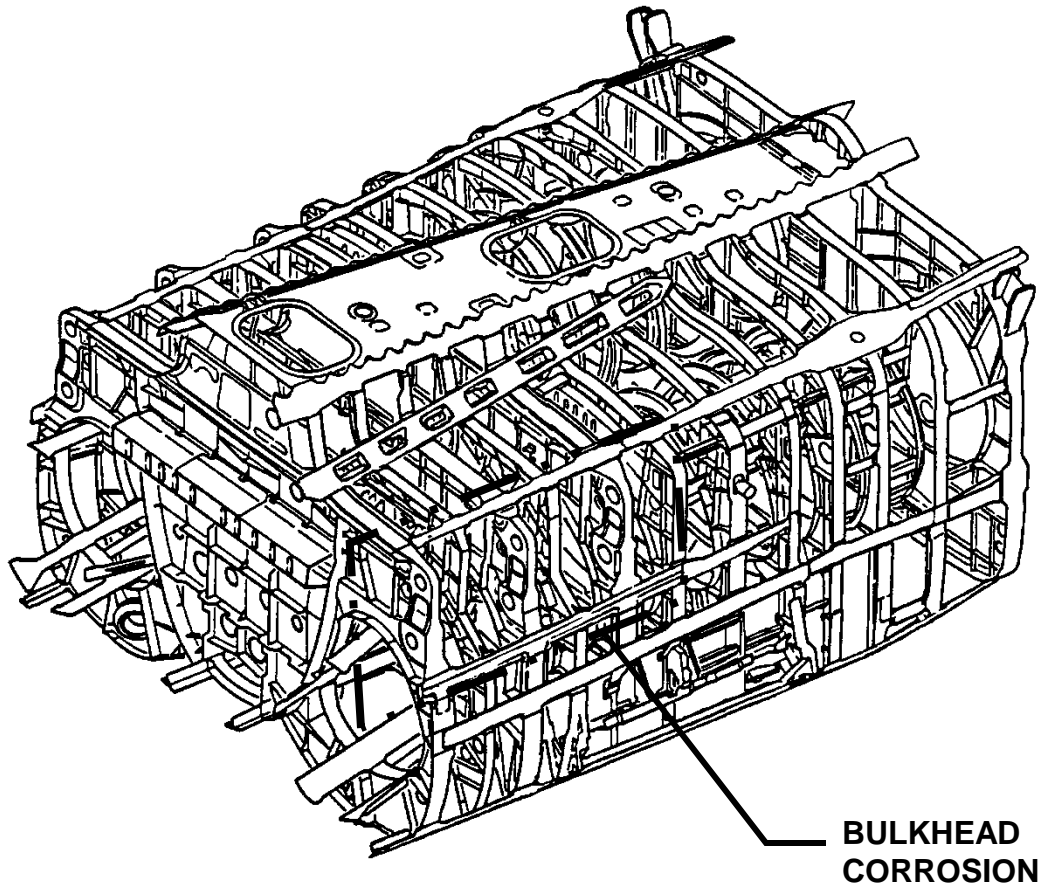

WING-FUSELAGE ATTACH BULKHEADS



- Dissimilar Metals

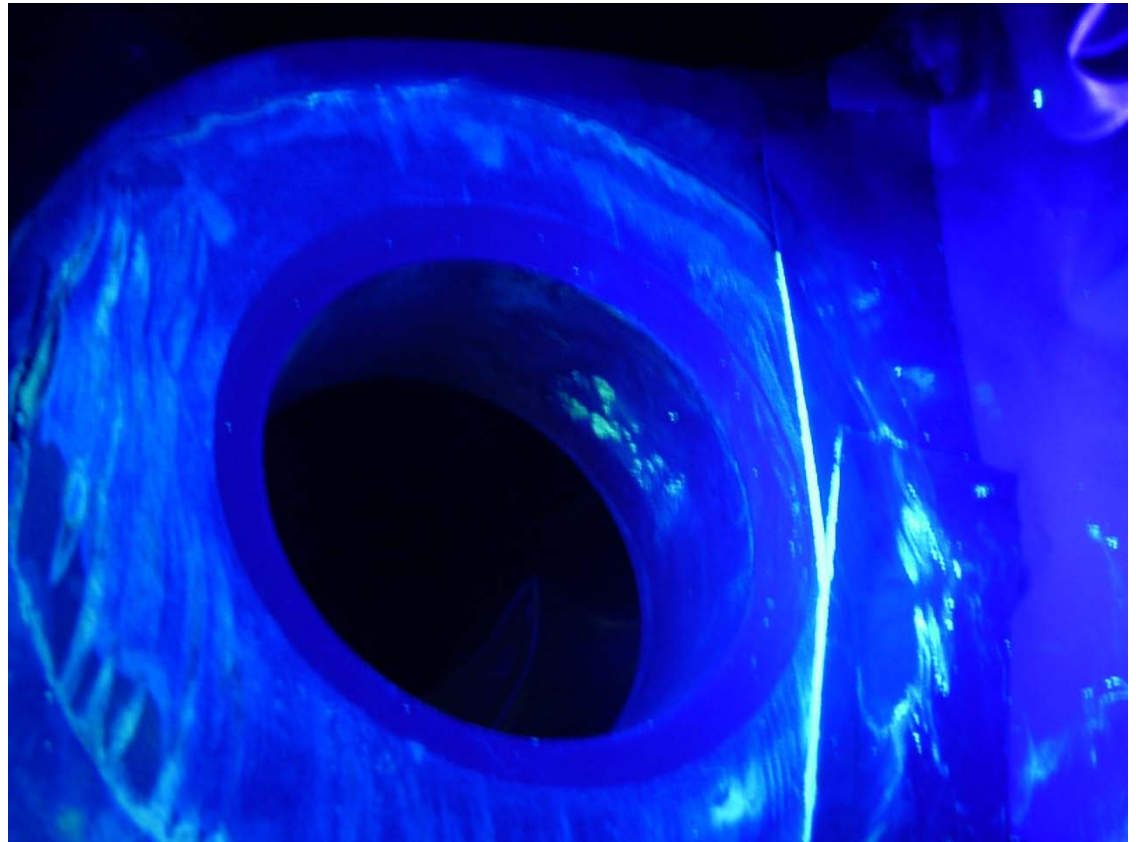
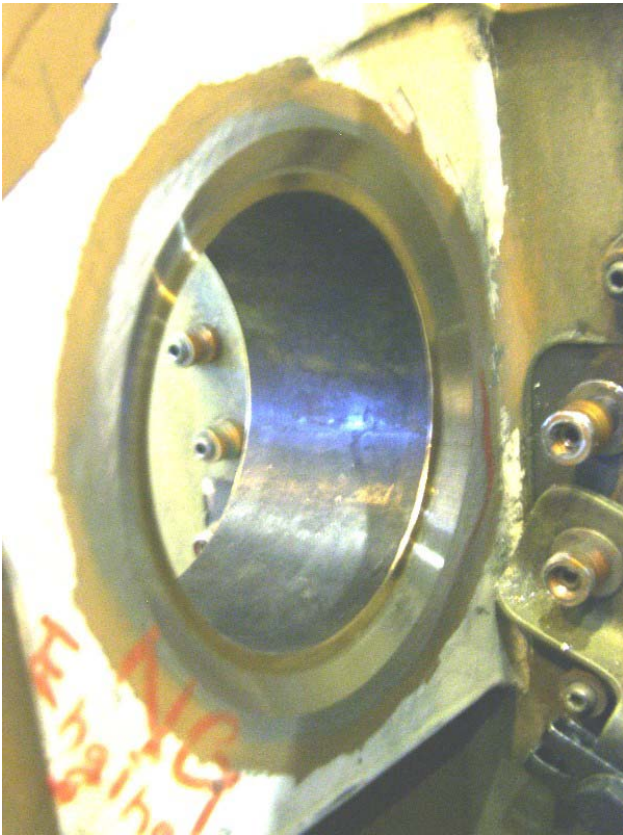

GALVANIC SERIES OF METALS AND ALLOYS IN SEA WATER

ANODIC (High corrosion potential)

Magnesium Alloys
 Zinc (plate)
 Beryllium
 Cadmium (plate)
 Uranium (depleted)
 Aluminum Alloys
 Indium
 Tin (plate)
 Stainless Steel 430 (active)
 Lead
 1010 Steel
 Cast Iron
 Stainless Steel 410 (active)
 Copper (plate)
 Nickel (plate)
 AM 350 (active)
 Chromium (plate)
 Stainless Steels 350, 310, 301, 304 (active)
 Stainless Steels 430, 410 (passive)
 Stainless Steel 13-8, 17-7 PH (active)
 Brass, Yellow, Naval
 Stainless Steel 316L (active)
 Bronze 220
 Copper 110
 Stainless Steel 347 (active)
 Copper-Nickel 715
 Stainless Steel 202 (active)
 Monel 400
 Stainless Steel 202 (active)
 Stainless Steels 321, 316 (active)
 Stainless Steels 309, 13-8, 17-7 PH (passive)
 Stainless Steels 304, 301, 321 (passive)
 Stainless Steels 201, 316L (passive)
 Stainless Steel 286 (active)
 AM355 (passive)
 Titanium Alloys
 Am350 (passive)
 AM350 (passive)
 Silver
 Palladium
 Gold
 Rhodium
 Platinum
 Carbon/Graphite

CATHODIC (Low corrosion potential)



Y395 Inlet Nacelle Corrosion

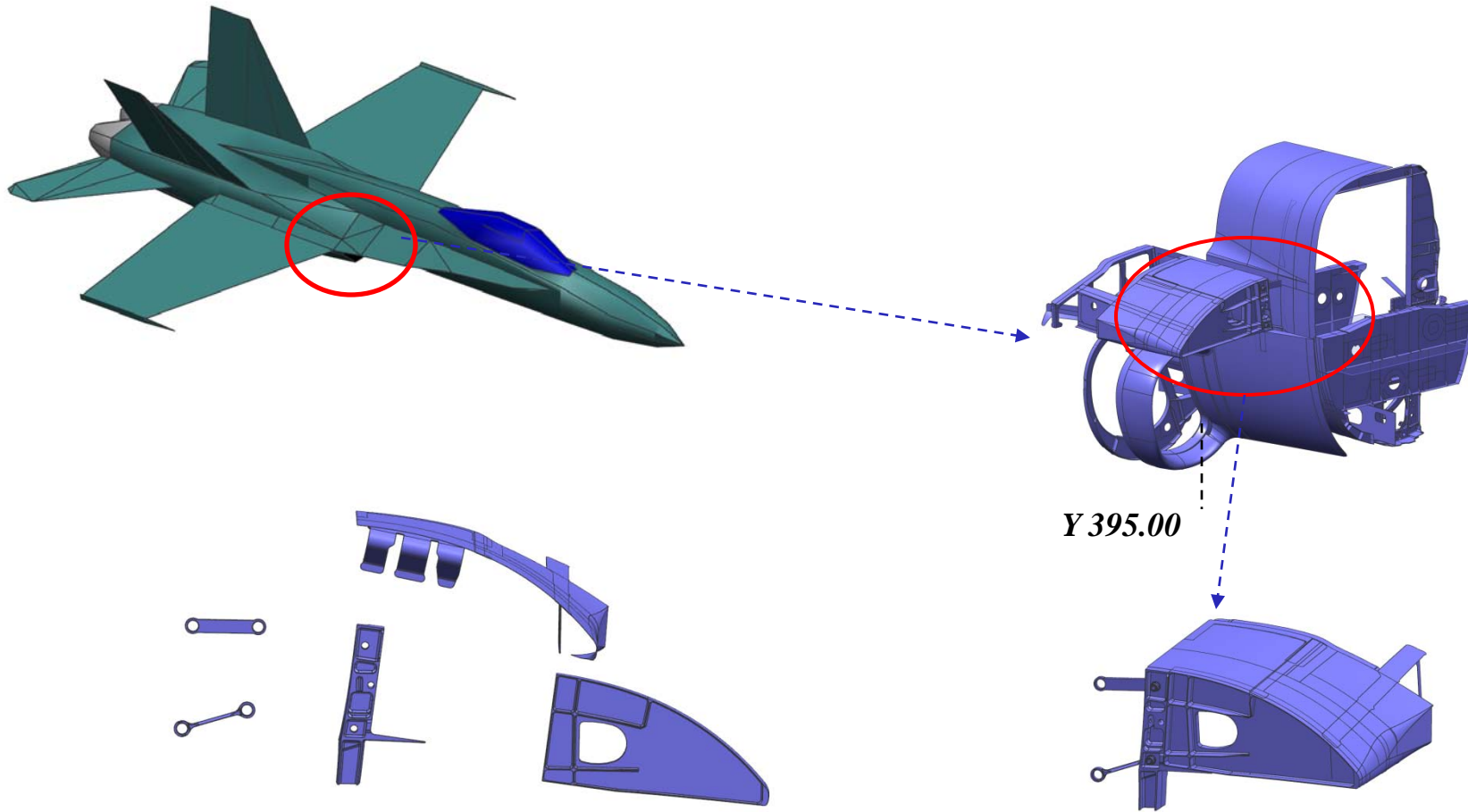

Exploded View of Y 395 Area

Y 395 Area



CORROSION ON Y395



IMAGEWARE USE

- Manipulate points into curves
- Curves into surfaces.

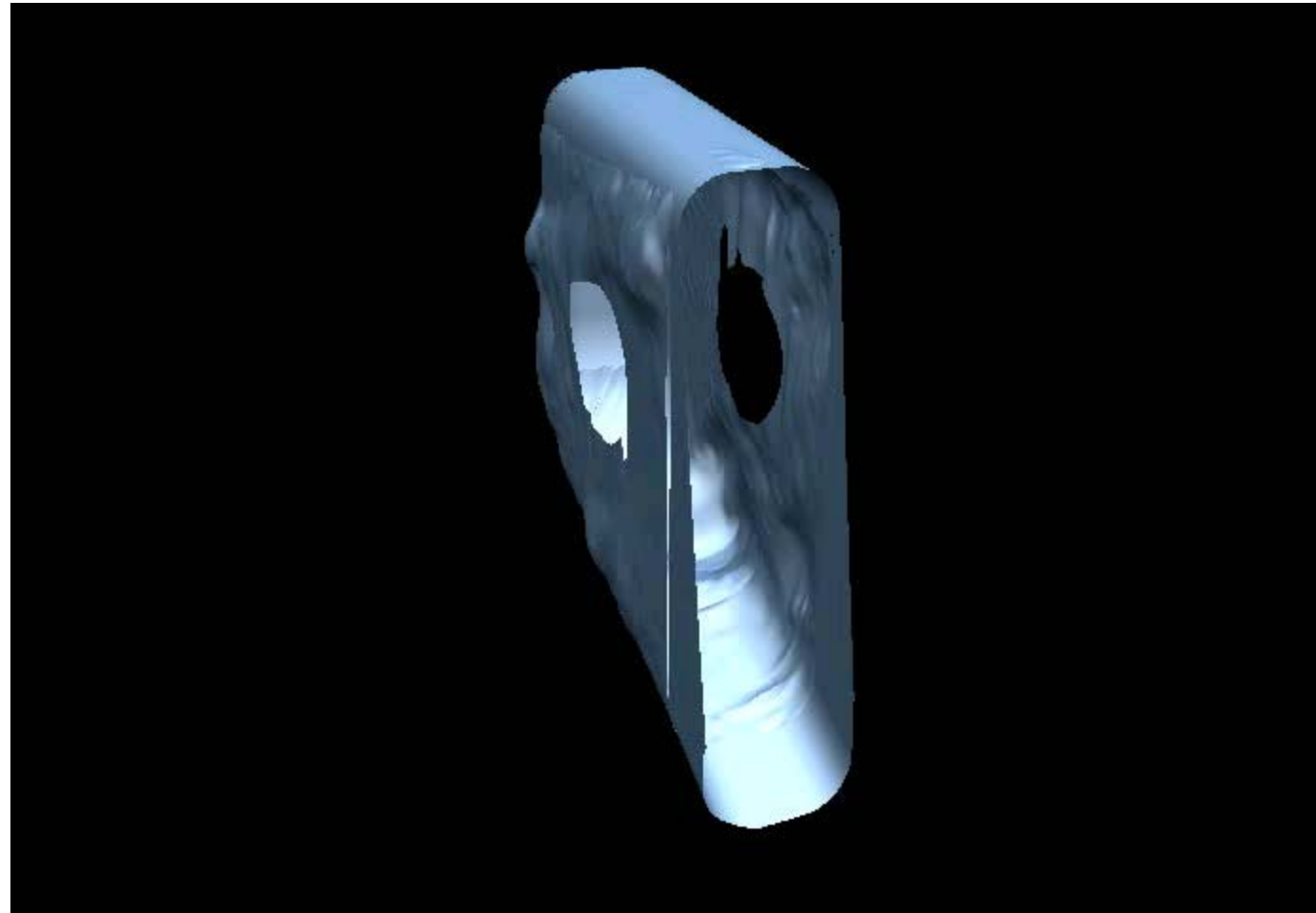

Pro/MECHANICA

- Finite Element Analysis
- Durability Assessment

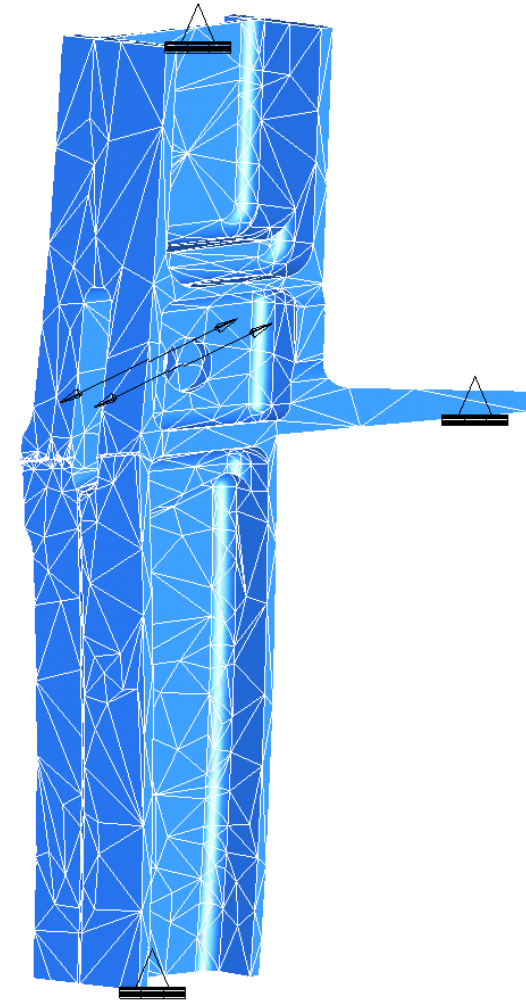
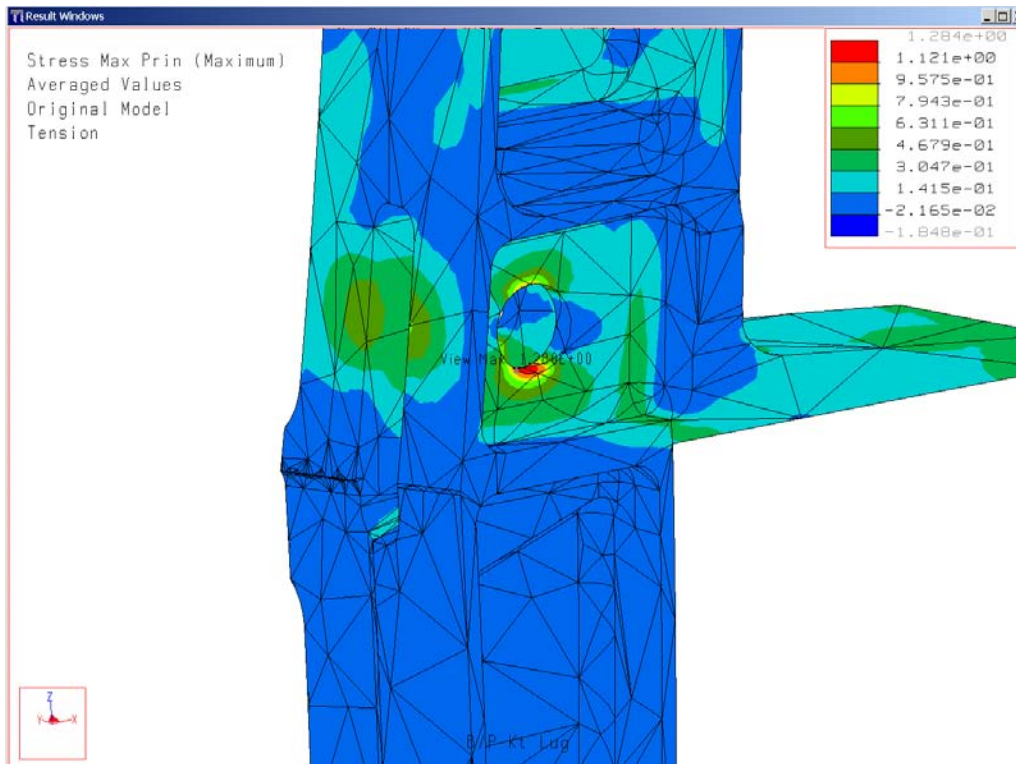

Current Analysis

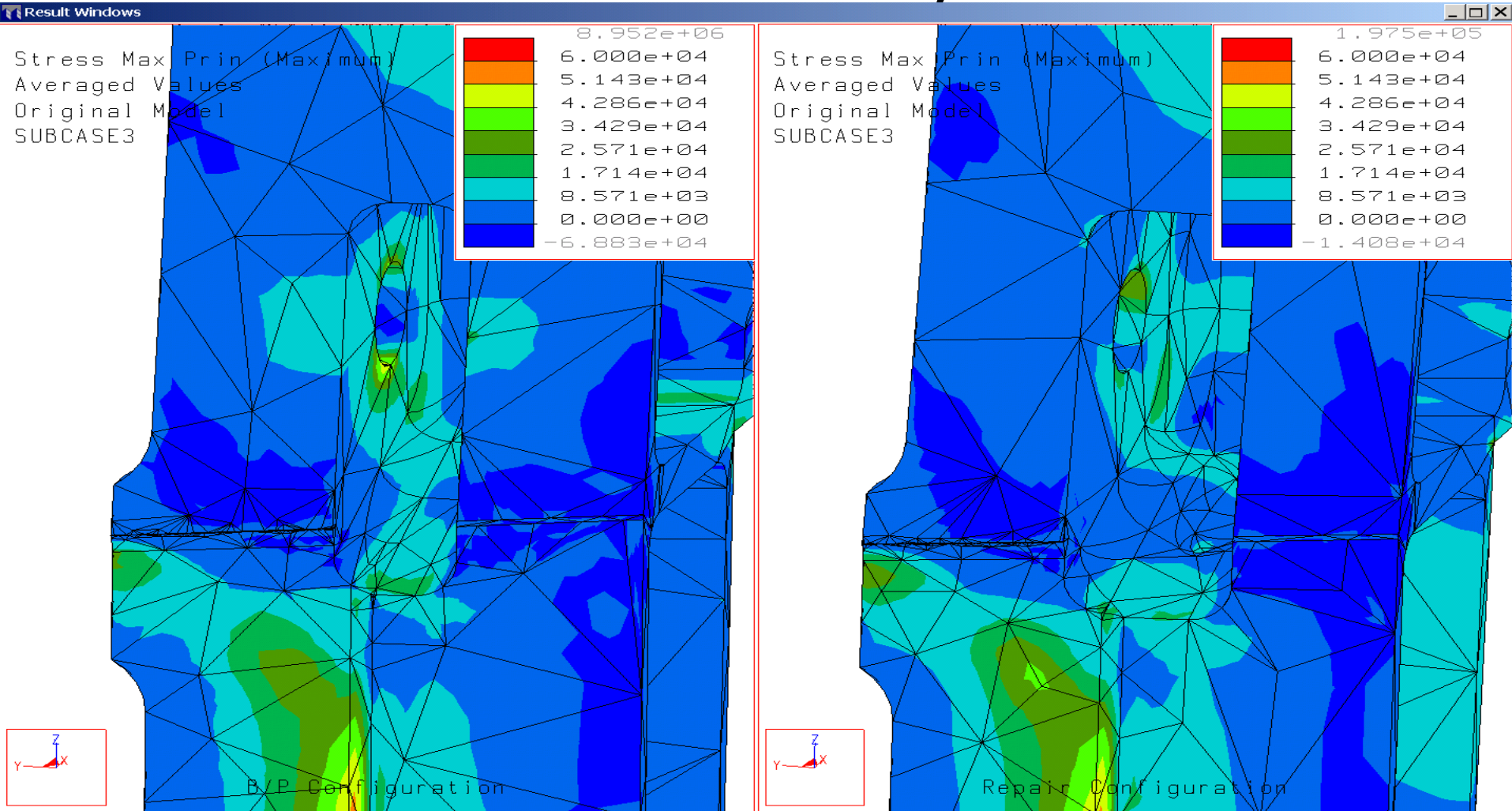

Y395 Former Corrosion

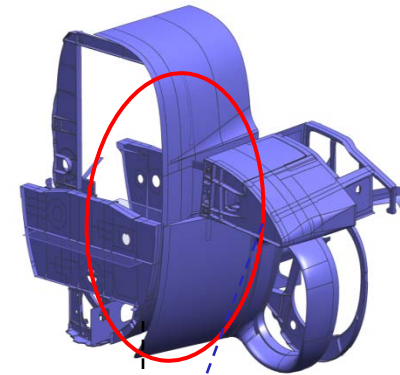
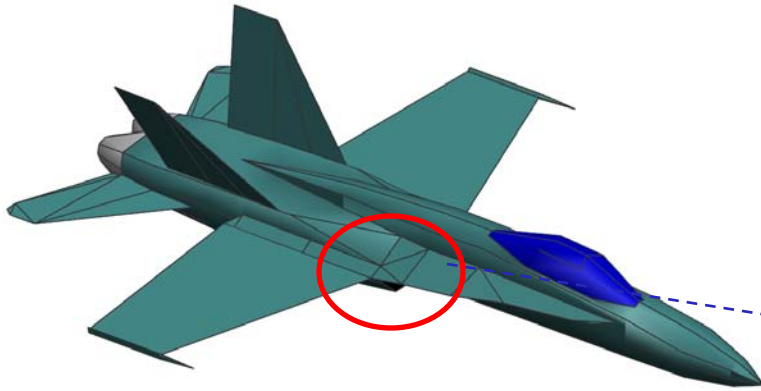

Y 395.00

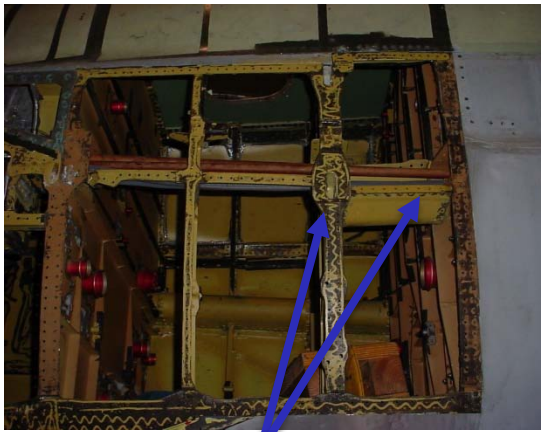

EXCCESIVE CORROSION INSIDE CLEVIS

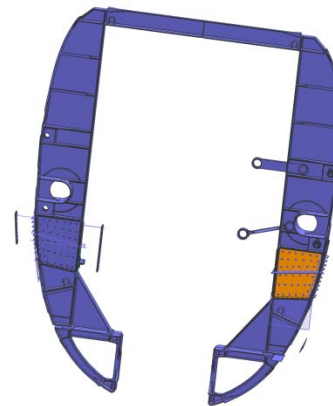

Y 395 Former



Y395 Corrosion Repair on Fuselage

- Y395
Prior to
removal.

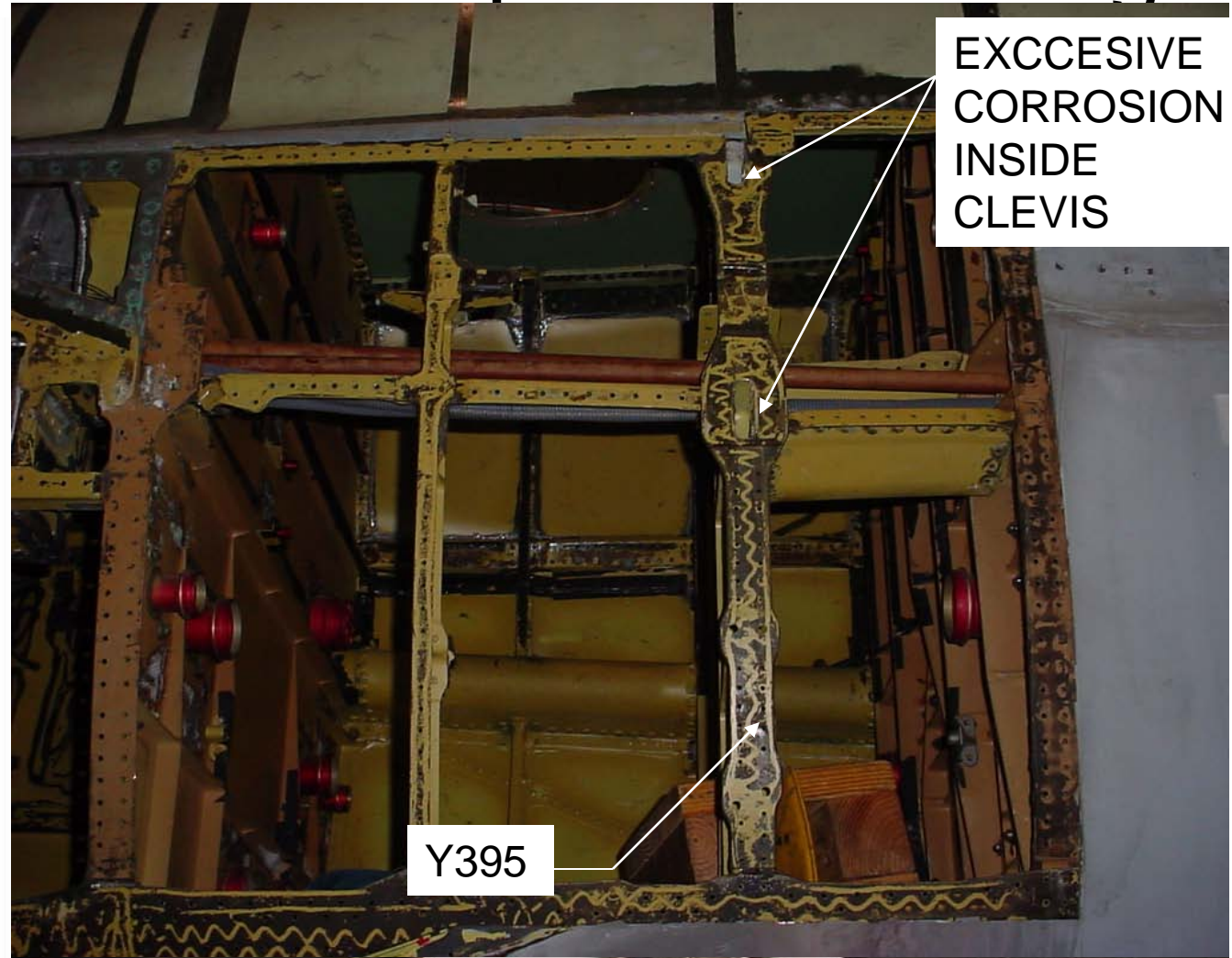

Y395 Corrosion Repair on Fuselage



Questions?

