

Design and Development of High Speed Fiber-Optic Transmit and Receive Network for Ground Vehicle Applications

Ashok Sood, Sriraj Bhadra, Paul Smith and Yash R. Puri[†]
Magnolia Optical Technologies Inc., 52-B Cummings Park, Woburn, MA 01801*

Jason Ueda, and Mitch Cross
Vetronics Group, U.S. Army Tank-Automotive Command, Warren, MI 48397

J. Jiang Liu, Wayne Chang and George Simonis
US Army Research Laboratory, 2800 Powder Mill Road, Adelphi, MD 20783

ABSTRACT

High Speed Multi-Channel Fiber-Optic Transmitter (Tx) and Receiver (Rx) modules are needed for Army's Ground Vehicle Applications. The fiber optic network should take advantage of the high speeds (10 Gbps/channel) and have the ability to connect multiple systems and sensors using a rugged fiber-optic network capable of working with 100's of Gigabits of information. In addition, the network should provide redundant links between nodes so that in case one node goes out of service, the remainder of the network remains operational.

In this paper we will present design, development and performance results for 1x12 Tx and Rx module operating at 10Gbps/channel. Each of the 1x12 modules is capable of providing 120 Gbps/Module operations for Army's Applications. Experimental results on 1x12 channel modules will include performance characteristics at 10 Gbps and will demonstrate high performance fiber-optical Tx and Rx Modules.

We will also present architecture and simulation for a Fiber-Optic Network Card that has the capability to transmit and receive data, add and drop data at each node, and provide dual network redundancy. This network card includes Tx, Rx modules, serializer and de-serializer (SERDES) and a cross bar switch. This architecture can be used as a building block for high-speed local area network for the U.S. Army's applications.

INTRODUCTION

Developments and advances in information gathering and communications offer a new paradigm for high-speed communication links. The high speed optical modules reported here provides the capability of transferring data at 10 Gbps/channel and hence can be applicable to high speed short range networks, back plane connectivity for network systems and high resolution imaging system. The modules have significant potential for military communication applications, especially for short distances such as in a ground vehicle. The optical transmitters currently commercially available have 12 channels at 2.5 Gbps^{1,2} or single channel 10 Gbps. The electrical architecture for 10 Gbps data

[†] Also, Professor, University of Massachusetts Lowell.

Report Documentation Page

Form Approved
OMB No. 0704-0188

Public reporting burden for the collection of information is estimated to average 1 hour per response, including the time for reviewing instructions, searching existing data sources, gathering and maintaining the data needed, and completing and reviewing the collection of information. Send comments regarding this burden estimate or any other aspect of this collection of information, including suggestions for reducing this burden, to Washington Headquarters Services, Directorate for Information Operations and Reports, 1215 Jefferson Davis Highway, Suite 1204, Arlington VA 22202-4302. Respondents should be aware that notwithstanding any other provision of law, no person shall be subject to a penalty for failing to comply with a collection of information if it does not display a currently valid OMB control number.

1. REPORT DATE

18 MAY 2004

2. REPORT TYPE

Journal Article

3. DATES COVERED

18-05-2004 to 18-05-2004

4. TITLE AND SUBTITLE

Design and Development of High Speed Fiber-Optic Transmit and Receive Network for Ground Vehicle Applications

5a. CONTRACT NUMBER

DAAE07-03-C-L001

5b. GRANT NUMBER

5c. PROGRAM ELEMENT NUMBER

6. AUTHOR(S)

Michael Ueda; Mitch Cross; Ashok Sood; Wayne Chang; George Simonis

5d. PROJECT NUMBER

5e. TASK NUMBER

5f. WORK UNIT NUMBER

7. PERFORMING ORGANIZATION NAME(S) AND ADDRESS(ES)

Magnolia Optical Technologies, 52-B Cummings Park, Woburn, MA, 01801

8. PERFORMING ORGANIZATION REPORT NUMBER

; #14087

9. SPONSORING/MONITORING AGENCY NAME(S) AND ADDRESS(ES)

U.S. Army TARDEC, 6501 E.11 Mile Rd, Warren, MI, 48397-5000

10. SPONSOR/MONITOR'S ACRONYM(S)

TARDEC

11. SPONSOR/MONITOR'S REPORT NUMBER(S)

#14087

12. DISTRIBUTION/AVAILABILITY STATEMENT

Approved for public release; distribution unlimited

13. SUPPLEMENTARY NOTES

Presentation at NDIA's 4th Annual Intelligent Vehicle Systems Symposium & Exhibition

14. ABSTRACT

High Speed Multi-Channel Fiber-Optic Transmitter (Tx) and Receiver (Rx) modules are needed for Army's Ground Vehicle Applications. The fiber optic network should take advantage of the high speeds (10 Gbps/channel) and have the ability to connect multiple systems and sensors using a rugged fiber-optic network capable of working with 100's of Gigabits of information. In addition, the network should provide redundant links between nodes so that in case one node goes out of service, the remainder of the network remains operational. In this paper we will present design, development and performance results for 1x12 Tx and Rx module operating at 10Gbps/channel. Each of the 1x12 modules is capable of providing 120 Gbps/Module operations for Army's Applications. Experimental results on 1x12 channel modules will include performance characteristics at 10 Gbps and will demonstrate high performance fiber-optical Tx and Rx Modules. We will also present architecture and simulation for a Fiber-Optic Network Card that has the capability to transmit and receive data, add and drop data at each node, and provide dual network redundancy. This network card includes Tx, Rx modules, serializer and de-serializer (SERDES) and a cross bar switch. This architecture can be used as a building block for high-speed local area network for the U.S. Army's applications.

15. SUBJECT TERMS

16. SECURITY CLASSIFICATION OF:			17. LIMITATION OF ABSTRACT Public Release	18. NUMBER OF PAGES 7	19a. NAME OF RESPONSIBLE PERSON
a. REPORT unclassified	b. ABSTRACT unclassified	c. THIS PAGE unclassified			

Standard Form 298 (Rev. 8-98)
Prescribed by ANSI Std Z39-18

transmission is quite different from the low speed optical module architectures. The 12 channel 10 Gbps/channel optical modules presented in this paper provides a robust, easy to assemble packaging solution. The modules are also operable at lower data rates.

This paper presents the design, development and performance of 12 Channel parallel optics Transmitter (Tx) and Receiver (Rx) module at 10 Gbps/channel. The optical modules use Vertical Cavity Surface Emitting Lasers (VCSEL) for the transmitter technology and p-i-n detector technology for the receiver, since these are the technologies that will allow achieving the target speed. The optical modules operate at 850 nm and hence can be easily coupled to multi-mode fibers. The 12 channel modules are optically coupled using multi fiber connectors and 12 channel multimode ribbon cable. The high-speed optical modules are used in a network card at a node, and have the capability to transfer data to the next node as well as add and drop data at each node. The 12 channel high-speed optical modules presented here provide the network card the capability of transferring 120 Gbps to the next node. The network card adds and drops data through a high-speed electrical connector or optical link.

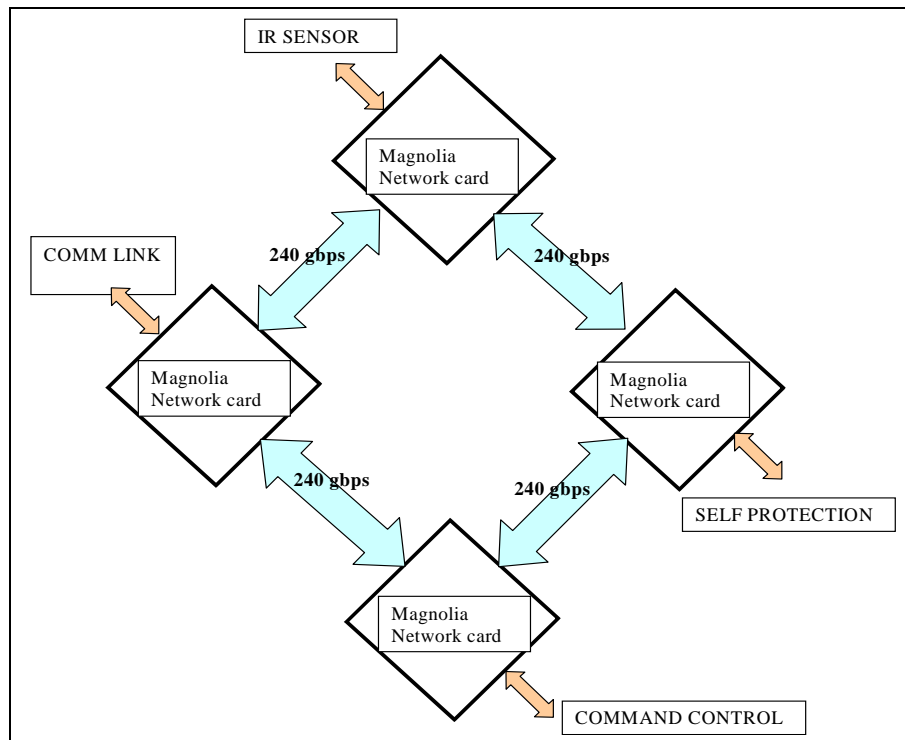

Fig. 1 Fiber-Optic Network architecture with built-in dual redundancy

Network redundancy is achieved by adding additional Transmitters (Tx) and Receivers (Rx) along with the support electronics for the transceiver in the module. The architecture described in this paper has two level redundancies and is shown in Figure 1. Each module is connected to two or more other modules. Thus, if one of the fiber optical links is severed the network will be complete through the other optical path.

TRANSMITTER AND RECEIVER OPTICAL MODULE DEVICE STRUCTURE

The Tx optical module consists of VCSEL driver and VCSEL array. The Rx optical module consists of photodiode array and TIA (Trans-impedance) array. Figure 1 shows the three dimension structure of the optical module. Both the Tx and Rx optical modules have the same form factor. Figure 2 shows the cross sectional view of the optical module and the placement of the optical and electrical components.

The VCSEL array and photodiode are mounted on top of a ceramic pedestal. The ceramic pedestal is used to maintain optical flatness and also adjust the VCSEL and photodiode height to achieve the required optical distance from the micro lens array. The VCSEL and photodiode array are mounted on a pedestal and the pedestal is mounted on the PC board. Both the VCSEL driver and TIA array also are mounted on the PC board. The VCSEL array and the VCSEL driver are chip to chip wire bonded for best signal integrity. The photodiode and TIA array are wire bonded for similar reasons. The optical devices are mounted using thermally conductive epoxy for heat diffusion.

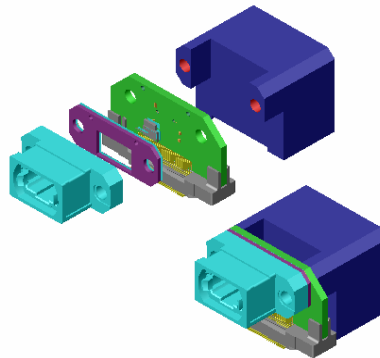

Fig. 2 Three dimensional structure of optical module

The PC board is fabricated using FR4 material and the high-speed 10 Gbps lines are copper with gold plating. The driver and TIA chip of the transmitter and receiver, respectively, are wire bonded on the gold plated pads on the PC board. The high speed as well as the low speed lines are on either side of the PC Board and connect directly to the high-speed electrical connector at the bottom of the PC board. The electrical connector is mounted along with the PC board inside the module. The high-speed lines are less than 1 inch in length and are impedance matched for negligible signal distortion and attenuation. The PC boards have been designed with bond pads for wire bonding the VCSEL driver and TIA chip.

The electric connector provides the connection of the optical module. The connector consists of 12 high-speed (10 Gbps) differential connections and other low speed connectors for power, ground, setup and monitoring.

The optical multi fiber connector enables coupling of the optical signal to the ribbon cable. The connector has 12 arrays of micro lenses. The VCSEL and the Photodiode are placed at the edge of the connector and perfectly aligned to micro-lens array. A ceramic spacer with center cutout separates the connector and the PC Board thereby providing required distance for optical coupling. The back support of the optical module provides the mechanical support and facilitates heat sinking.

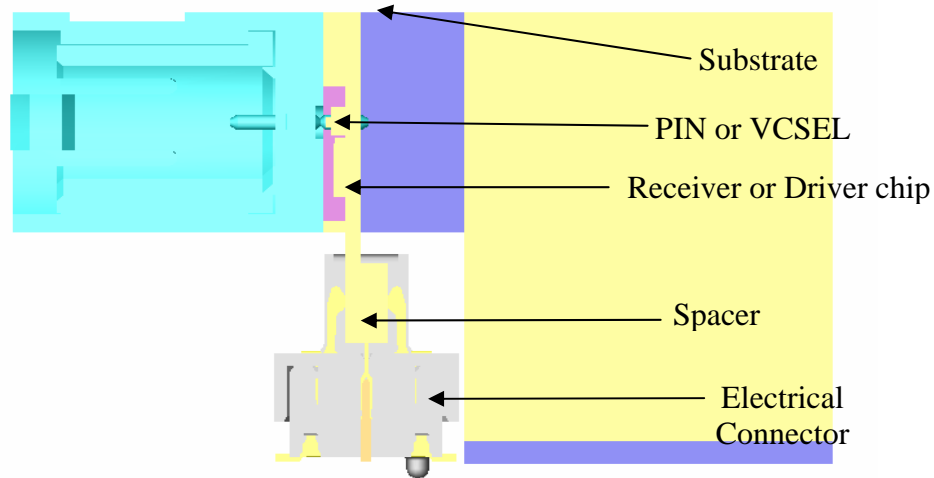

Fig. 3 Cross sectional view of the optical module

RESULTS

The Tx and Rx optical component performance is evaluated by forming a Transmitter–Receiver optical link. The transmitter is connected to the receiver by multimode fiber. Test cards were designed and optical components were mounted on the test cards. The test cards have SMA connectors to transmit/receive high-speed test signals to/from the Transmitter (Tx)/Receiver (Rx) optical components. SMA connectors couple the 10 Gbps electrical signal generated by the pattern generator to the Tx module and to connect the Rx module to the high-speed scope. The pattern generator trigger is used to synchronize the high-speed scope. The Bit Error Ratio Tester (BERT) is used both as a pattern generator and as a tester for the bit error for certain transmission lengths.

The 10 Gbps PRBS signal from the signal generator modulates the Tx module, and the optical signal is then transmitted to the Rx module by a multimode fiber cable. The receiver optical module converts the optical high speed signal to high speed electrical pulses and is then displayed on a high speed scope. The high-speed oscilloscope is triggered with clock of the PRBS generator and the eye diagram is the superposition of many measurements of the bit pattern shown in Figures 4 and 5. The PRBS ($2^{11} - 1$) signal is generated from a BERT and it also tests the Bit errors for certain PRBS patterns. Thus, the eye diagram indicates the quality of the signal and bit error measures the number of bits erroneously received. The BERT matches the received pattern against the transmitted pattern and hence determines the error.

Table I shows the data for the Tx-Rx optical link. The eye diagrams demonstrate the speed of the optical signal. The time scale of 100 ps for each bit pattern demonstrates the 10 Gbps performance. The BER (Bit Error Ratio) measured was 10^{-12} at 10 Gbps. Figure 4 shows the link performance for 10 Gbps channel speed. Figure 5 demonstrates that the optical modules can be operated a lower speed with good signal quality.

TABLE I: Transmitter-Receiver Communication Single Channel Link Data

Transmitter(Tx) – Receiver (Rx) Link Modulation Current = 9 mA	Rise (ps)	Fall (ps)	P-P jitter(ps)
Tx Ch2 – Rx Ch 2	36.8	35.4	31.8
Tx Ch5 – Rx Ch 5	36.6	34.6	23.6
Tx Ch8 – Rx Ch 8	44.8	43.6	31.8
Tx Ch10 – Rx Ch 10	37	36.2	23.2

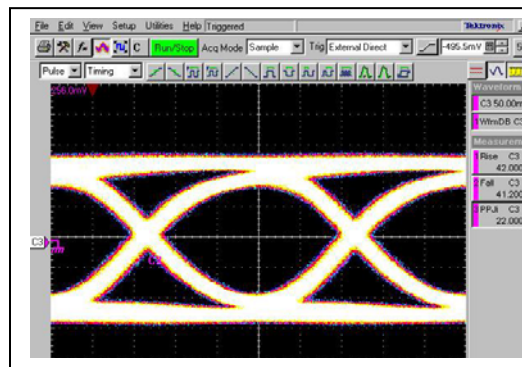
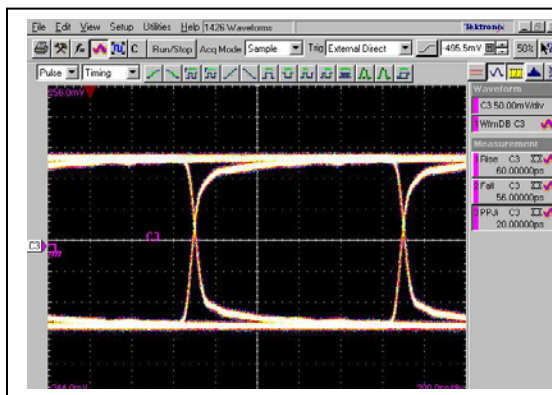
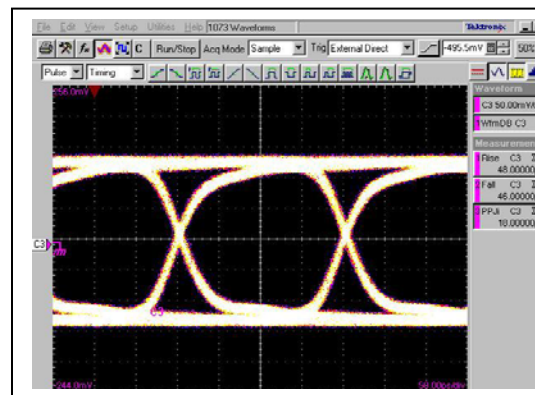

Fig. 4 Transmitter (Tx) Channel 8 to Receiver (Rx) Channel 8 communication 10 Gbps eye-diagram at 9 mA modulation current



(a)



(b)

Fig. 5 Lower speed eye-diagram for (a) 5 Gbps and (b) 1 Gbps

NETWORK CARD APPLICATION

The 12 Channel optical modules are applicable to a network card and can transmit and receive the data. The Network card can be placed at each node in the network. Thus, each data link connecting the nodes will have a transmit capacity of 120 Gbps and a receive capacity of 120 Gbps. The combined Tx/Rx capacity of each link will therefore be 240 Gbps. The network card can be designed to have two level redundancies and the schematic diagram is shown in Figure 6. Each of the network cards will have three high-speed data links to add/drop data. They can be RF connectors or high-speed optical link. The card also has SerDes (serializer/de-serializer) chips to convert high speed 10 Gbps signals to four lower speed 3.125 Gbps signals and vice versa. This makes the data speed compatible to the lower speed crosspoint switch. As 10 Gbps crosspoint switches become available, most of the SerDes will be eliminated.

The network card architecture is based on the 10Gbe format (10 Gigabit Ethernet) using standardized components for switching and serialization. All the data entering or leaving the network card must be in the 10GbE format, either in a single bit stream or in a quad bit-stream (X Application Unit Interphase format). Fiber connections will provide twenty-four of the 10 gigabit channels with the remaining three channels in either 10G serial, XAUI, or optical format.

The card is configured as a switching device with local microprocessor control. Switching is often referred to as a telecom switch, meaning that a signal path is connected and remains connected for the duration of the transmission. In this case the 10G lines will be connected and remain connected as long as path continuity is established. Once continuity is broken, the path will be rerouted to another line.

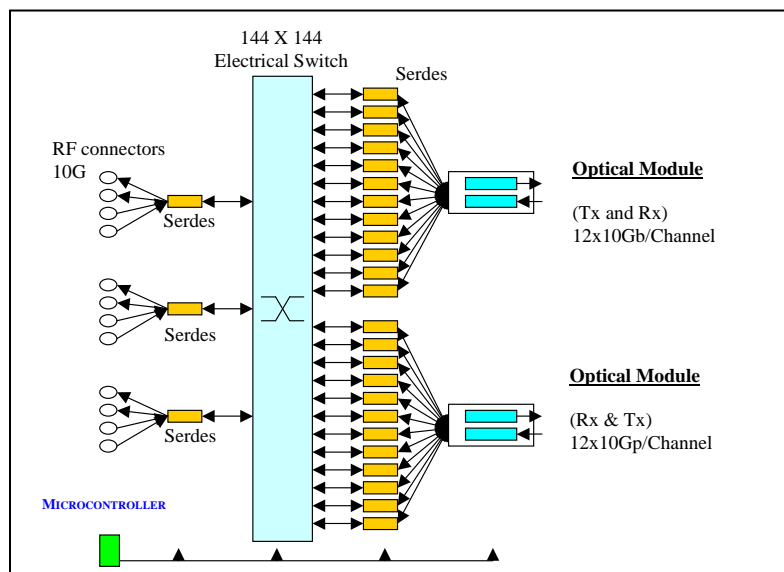

Figure 6. Network Card Block diagram

CONCLUSION

Ultra high speed data communications for the short range are not yet available in the commercial market. The optical modules developed by Magnolia have a variety of applications for the short-range requirements. The network card embodies a simple architecture that allows transmission and receipt of 120 Gbps data concurrently. In addition, Magnolia network card has built-in dual redundancy.

There are many possible applications of this technology within the Department of Defense. This architecture can provide the capability to transfer very high resolution imagery, map data, and other required command and communication information inside a ground vehicle. Using the network card, the data can be rapidly transmitted from one location to another inside the vehicle to the actual point of use.

In addition to defense application, these modules can be used in commercial applications for storage area networks, back-plane connectivity, video surveillance, and other areas where very large data transmission is required over short distances.

***ACKNOWLEDGEMENT**

This work is funded in part by the US Army TACOM Program under contract number DAAE07-03-C-L001.

REFERENCES

1. Parallel Optical Interconnects Lisa A. Buckman et. al, Conference on Lasers and Electro-Optics 2000
2. 4 Channel Very Short Reach 10 GbE Optical Transceiver , Sam Kim IEEE Interim Meeting New Orleans, LA Sept 2000