

**Evaluation Methodology for Surface Engineering  
Techniques to Improve Powertrain Efficiency in  
Military Vehicles**

**by Brian D. Dykas, LTC David B. Stringer, and Kelsen E. LaBerge**

**ARL-TR-6028**

**June 2012**

## **NOTICES**

### **Disclaimers**

The findings in this report are not to be construed as an official Department of the Army position unless so designated by other authorized documents.

Citation of manufacturer's or trade names does not constitute an official endorsement or approval of the use thereof.

Destroy this report when it is no longer needed. Do not return it to the originator.

# **Army Research Laboratory**

Aberdeen Proving Ground, MD 21005

---

---

**ARL-TR-6028**

**June 2012**

---

## **Evaluation Methodology for Surface Engineering Techniques to Improve Powertrain Efficiency in Military Vehicles**

**Brian D. Dykas, LTC David B. Stringer, and Kelsen E. LaBerge,  
Vehicle Technology Directorate, ARL**

REPORT DOCUMENTATION PAGE			Form Approved OMB No. 0704-0188		
Public reporting burden for this collection of information is estimated to average 1 hour per response, including the time for reviewing instructions, searching existing data sources, gathering and maintaining the data needed, and completing and reviewing the collection information. Send comments regarding this burden estimate or any other aspect of this collection of information, including suggestions for reducing the burden, to Department of Defense, Washington Headquarters Services, Directorate for Information Operations and Reports (0704-0188), 1215 Jefferson Davis Highway, Suite 1204, Arlington, VA 22202-4302. Respondents should be aware that notwithstanding any other provision of law, no person shall be subject to any penalty for failing to comply with a collection of information if it does not display a currently valid OMB control number. <b>PLEASE DO NOT RETURN YOUR FORM TO THE ABOVE ADDRESS.</b>					
1. REPORT DATE (DD-MM-YYYY) June 2012		2. REPORT TYPE Final		3. DATES COVERED (From - To) 1 March 2010 to 1 March 2012	
4. TITLE AND SUBTITLE Evaluation Methodology for Surface Engineering Techniques to Improve Powertrain Efficiency in Military Vehicles			5a. CONTRACT NUMBER		
			5b. GRANT NUMBER		
			5c. PROGRAM ELEMENT NUMBER		
6. AUTHOR(S) Brian D. Dykas, PhD, PE, LTC David B. Stringer, PhD, and Kelsen E. LaBerge, PhD			5d. PROJECT NUMBER 2009QRF0022		
			5e. TASK NUMBER		
			5f. WORK UNIT NUMBER		
7. PERFORMING ORGANIZATION NAME(S) AND ADDRESS(ES) U.S. Army Research Laboratory ATTN: RDRL VTD Aberdeen Proving Ground, MD 21005			8. PERFORMING ORGANIZATION REPORT NUMBER ARL-TR-6028		
9. SPONSORING/MONITORING AGENCY NAME(S) AND ADDRESS(ES) Assistant Secretary of Defense for Research and Engineering			10. SPONSOR/MONITOR'S ACRONYM(S)		
			11. SPONSOR/MONITOR'S REPORT NUMBER(S)		
12. DISTRIBUTION/AVAILABILITY STATEMENT Approved for public release; distribution unlimited.					
13. SUPPLEMENTARY NOTES					
14. ABSTRACT The Assistant Secretary of Defense for Research and Engineering (ASDR&E) is sponsoring a research effort to investigate whether surface engineering techniques, to include superfinishing and the application of nickel-based coatings, can yield tangible gains in power transfer efficiency within military vehicle drivetrains. This report details the experimental methodology developed by the U.S. Army Research Laboratory to characterize efficiency and durability improvements available through the application of these surface engineering techniques to various mechanical components. The primary goal of the initial phase of evaluation is to experimentally measure the efficiency of gears and other tribological components with and without these surface treatments. At the basic research level, these experiments are conducted on test coupons. At the applied research level, experiments are conducted on a subsystem component of a vehicle drivetrain. A parallel basic research thrust includes computational modeling of interacting gears to advance predictive tools for improved gear surface design. Initial durability studies characterize the fatigue properties of each technique. Finally, friction and wear measurements are conducted on specimens representative of diesel engine components, in order to determine any benefits of surface treatment to reciprocating mechanical components.					
15. SUBJECT TERMS Surface engineering, gear efficiency, powertrain, tribology					
16. SECURITY CLASSIFICATION OF:			17. LIMITATION OF ABSTRACT UU	18. NUMBER OF PAGES 24	19a. NAME OF RESPONSIBLE PERSON Brian D. Dykas
a. REPORT Unclassified	b. ABSTRACT Unclassified	c. THIS PAGE Unclassified			19b. TELEPHONE NUMBER (Include area code) (410) 278-9545

---

## Contents

---

<b>List of Figures</b>	<b>iv</b>
<b>List of Tables</b>	<b>iv</b>
<b>Acknowledgments</b>	<b>v</b>
<b>1. Introduction</b>	<b>1</b>
<b>2. Methodology</b>	<b>1</b>
2.1 Superfinishing .....	2
2.2 Hard Coatings.....	2
<b>3. Research Thrusts</b>	<b>3</b>
3.1 Task 1: Application Development, Coatings and Finishes for Mechanical Components.....	3
3.2 Task 2: Characterization of Surface Topography and Material Properties in Research Specimens.....	5
3.3 Task 3: Basic Research to Characterize Friction, Wear, Efficiency, Loss-of-oil, and Lubricant Compatibility Behavior of Engineered Surfaces .....	6
3.4 Task 4: Powerplant Component Experiments: Piston Ring and Cylinder Liner Friction and Wear.....	8
3.5 Task 5: Transmission Component Experiments: Fatigue Characterization in Spur Gears.....	9
3.6 Task 6: Transmission Subsystem Experiments: Gear Efficiency in the HMMWV Rear Axle .....	10
<b>4. Concluding Remarks</b>	<b>11</b>
<b>5. References</b>	<b>13</b>
<b>List of Symbols, Abbreviations, and Acronyms</b>	<b>15</b>
<b>Distribution List</b>	<b>16</b>

---

## List of Figures

---

Figure 1. Typical confocal laser microscope images showing surface texture and fracture surface in a gear specimen. ....	5
Figure 2. Disk-on-roller test setup for friction, wear, and scuffing tests. ....	7
Figure 3. Disk on roller test rig (left) and specimen contact arrangement (right) for basic friction and wear characterization research (courtesy The Ohio State University). ....	7
Figure 4. Diagram of reciprocating wear tribometer for coated piston ring experiments. ....	8
Figure 5. Diagram of gear rolling contact fatigue test rig used to investigate contact fatigue life in spur gears. ....	9
Figure 6. Image of the National Aeronautics and Space Administration (NASA)/U.S. Army Research Laboratory (ARL) single gear-tooth bending-fatigue apparatus. ....	10
Figure 7. Photograph of the hypoid ring and pinion gears from the M1097A2 rear axle. ....	11

---

## List of Tables

---

Table 1. Disk-on-roller test matrix (5120 specimens will be tested using 80W20 oil and 9310 specimens will be tested using Aeroshell 555). ....	7
---	---

---

## **Acknowledgments**

---

We wish to acknowledge the guidance and support of the National Aeronautics and Space Administration, particularly Drs. Tim Krantz and Bob Handschuh. Kevin Radil of the U.S. Army Research Laboratory is thanked for establishing a methodology for, and conducting the piston ring experiments. Todd Smith and Rich Franciola of the Dana Corporation are thanked for their gracious support and advice in developing the axle test methodology. The assistance of Dr. Ahmet Kahraman and Mr. Sam Shon of the Ohio State University under the cooperative research agreement #W911NF-10-2-0033 is also acknowledged. The collaboration of Mr. Doug Fussner and Mr. Randy McDonnell of the Southwest Research Institute and Ms. Denise Rizzo of the U.S. Army Tank and Automotive Research Development and Engineering Center is greatly appreciated in the design of a dynamometer test protocol.

INTENTIONALLY LEFT BLANK.

---

## 1. Introduction

---

It is generally accepted that various methods of surface engineering can have large impacts on the power transmission efficiency of gearing, with superfinishing showing particular promise in vehicle applications (1–2). However, ground vehicles (both military and commercial) are subject to more stringent cost constraints than air vehicles such as helicopters. As a result, surface processing techniques may not be employed to optimize fuel efficiency, although these processes are becoming more common in recent years.

In general, the elastohydrodynamic lubrication (EHL) that occurs in gearing must be considered as a tribological system (gear surfaces, base oil, additives, surface chemistry, etc.) such that a change in one component may require significant changes in other parts of the tribological system. In this study, however, there are constraints on changes to the lubricant and gear geometry, so even though the surface engineering techniques may show improvement, the resulting system has not been optimized.

Despite these constraints, this work examines two types of surface engineering on gears to determine their influence on efficiency. These methods include high degrees of polishing (commonly referred to as superfinishing) as well as a hard inorganic coating. As surface roughness improves, the ratio of film thickness to roughness amplitude ( $\lambda$  ratio) increases, and with this improved film, the sliding contacts may see reduced friction. Similarly, hard coatings may serve to lessen frictional losses in portions of the EHL contact, where even small amounts of asperity interaction occur between the gear surfaces. The initial investigation considers three commercial superfinish methods and one hard coating in order to validate the research methodology, which can be used for subsequent screening of candidate coatings and finishes. Following the base effort, additional phases of research are envisioned to consider other processing techniques and increase technology readiness of those methods showing promise.

---

## 2. Methodology

---

This work employs a number of research efforts at the basic and applied research level to advance theoretical and practical understanding of drivetrain component efficiencies within the constraints of current and near-future military vehicles. The project is subdivided into several tasks to develop surface engineering technologies suitable for gears and other mechanical components (technology readiness level [TRL] 1–2), investigate “coupon-level” fundamental tribology (TRL 3), conduct component-level investigations of efficiency in gears and engine components (TRL 4), and evaluate subsystem-level efficiency to determine the achievable

efficiency gains in a relevant environment (TRL 5). This research portfolio provides a broad understanding of the fundamental physical mechanisms and practical improvements required to field surface engineering technologies for reduced fuel consumption.

Within the scope of the initial effort, three methods of superfinishing were selected to benchmark their performance and determine if substantial differences between them could be detected. Additionally, an inorganic hard coating was selected out of the countless coating compositions, microstructures, and application methods that might be considered candidates for powertrain component coatings.

## **2.1 Superfinishing**

Reduction of surface roughness can lower friction losses in gearing, particularly where significant relative sliding occurs. Surface interaction is reduced, allowing a thicker lubricant film to form and potentially improving performance under loss of lubrication conditions owing to the reduced heat generation and improved surface separation. Several processes exist to achieve mirror-like surface finishes, but because these methods remove material in varying amounts, many are not appropriate to precision gearing, where the geometry may not be substantially altered by any finishing process. Uniform and slight, predictable amounts of material removal are characteristics of successful superfinishing methods.

One process found acceptable in precision gearing applications is a chemically accelerated vibratory finishing process using non-abrasive media (2). The patented process (3, 4) and surface finish achievable by the process is claimed to be better than  $2 \mu\text{in } R_a$  (near-mirror finish). Test specimens will be treated using this process and gear efficiency will be compared to baseline specimens with as-ground surface roughness.

Two additional superfinish processes are considered in this study. One is very similar to the abovementioned method, being a vibratory bowl process using non-abrasive media with a chemical solution. The last process is one developed for finishing wristwatch components and is considered a trade secret process. Depending on the initial condition of the material, the process claims to be able to achieve  $R_a$  surface roughness of  $<1 \mu\text{in}$  and can be tailored to filter specific roughness wavelengths out of the surface through a “micromachining” process.

## **2.2 Hard Coatings**

For many decades, hard solid lubricant coatings have been considered for use in vehicle powertrain components. Some achieve varying degrees of success in components that are exposed to relatively benign operating conditions or reasonably short lives. Mainly considering military vehicle gearing, this study requires that coatings demonstrate suitability for highly stressed, long life gears in order to be successful. Past efforts to develop coatings for these conditions have generally been unsuccessful. Hard coatings necessarily have an interface with the substrate whether a bond coat or gradient interface is used, and this often results in durability shortfalls when exposed to high contact stresses.

This sponsored research considers an electroless nickel-boron (NiB) coating ranging from 10–30  $\mu\text{m}$  in thickness. The NiB coatings under consideration have evolved over the past few decades from the time when the electroless nickel coating process was developed. The addition of boron to the coatings provides hard coatings with high lubricity and improved wear resistance. Further refinement of these coatings has yielded the current coating's formulation, which includes 5–6 wt.% boron. Recent research in NiB coatings can be found in references 6–11. There are countless suppliers of NiB coatings and any combination of process parameters including pre- and post-processing of substrate and coating that can have a dramatic effect on the resulting performance. As such, this study includes a limited effort to produce promising NiB coatings, but is focused more on the challenges associated with hard gear coatings and the methods used to screen and improve candidate coatings.

For surfaces having the same topography, it is assumed the major efficiency benefit of NiB-coated components is in the reduced coefficient of sliding friction compared to that of uncoated steels and to other competitor coatings. Reference 8 provides data showing a reduced friction coefficient for NiB coatings under testing in accordance with ASTM-D2712. Based on this information, it is thought that the most significant friction reductions will be achievable under mixed or boundary lubrication conditions where some direct sliding contact exists between the components. Low speed, high torque mechanisms will see the most benefit when compared to full film, high speed contacts.

---

### **3. Research Thrusts**

---

#### **3.1 Task 1: Application Development, Coatings and Finishes for Mechanical Components**

Candidate engineered surfaces require application-specific development and screening to achieve optimal performance. Superfinish methods generally require process tailoring to select appropriate process media and equipment, depending on the component geometry and starting surface. Particularly for gears, this tailoring is needed to ensure complete and uniform material removal so as not to substantially affect tooth form (*12*).

Superfinish suppliers were provided with representative coupons and specimens to process. Multiple iterations were conducted, depending on the results, until the resulting finish was deemed appropriate for the intended application. This finish varied by supplier, as determined by technical and economic constraints.

Because of the additional challenges associated with successful application of hard coatings to power-dense gears, a more extensive application-specific development process is required. Coating thickness, microstructure, bonding, and other characteristics must be engineered to achieve compatibility with the substrate and tribochemical system, as well as desirable mechanical properties and durability targets.

An initial supplier of the NiB coatings was engaged to conduct an extensive application development effort on these coatings, but was unable to complete the effort. A second supplier was identified, but the reduction in scope associated with the loss of the first supplier precluded significant NiB coating development from being accomplished.

Application development includes methods necessary to successfully apply coatings with desired thickness, hardness, and other material properties appropriate for powertrain gearing. As an example, the original technical plan for application-specific development of the electroless nickel-based coatings consisted of the following:

- Adapting existing electroless coating methods to the specimens of interest, including substrate material and geometry, adjusting coating process variables, and thermal treatments, as necessary.
- Employing appropriate engineering design and simulation tools to optimize process parameters for the application.
- Selecting coating parameters (hardness, surface finish, thickness) appropriate to the application.
- Designing and building racks to hold components in tank.
- Coating components.
- Fabricating and coating witness coupons and other material specimens, as necessary, to retain physical record of as-deposited coating.
- Conducting metrology, surface analysis, and metallography/fractography interrogations of samples to correlate microstructure with friction properties and verify material condition.

For application of both superfinishes and hard coatings, several gear configurations and other mechanical components were considered. These specimens were chosen to subject the treatments to a battery of experiments from simple and controlled coupon-level experiments through more complicated subsystem-level evaluation. The specimen configurations include the following:

- Roller/disc specimens for traction, wear, and scuffing experiments
- Spur gears for surface durability and gear efficiency experiments
- Spiral bevel gears for gear efficiency experiments
- High mobility multipurpose wheeled vehicle (HMMWV) axle hypoid rings and pinions for gear efficiency experiments
- Cylinder liner and piston ring specimens for reciprocating friction and wear experiments

### 3.2 Task 2: Characterization of Surface Topography and Material Properties in Research Specimens

Closely coupled with application-specific tailoring of engineered surfaces is the need to characterize the properties of these surfaces. Vast resources exist in the open literature regarding the mechanical properties desired for gearing and other powertrain components.

Characterization of the engineered surfaces, prior and subsequent to experiments, affords key insight into their success or failure. As such, this task executes pre- and post-experimental material property characterization of specimen surface treatments.

Pre-experiment characterization occurs on the unfinished ground, polished, and coated specimens. Pre-test characterization of the polished specimens verifies the performance of the polishing processes to achieve the desired surface roughness while protecting the form. Pre-test characterization of the coated specimens verifies mechanical and metallurgical properties, and assesses the performance of the coating operation. Of specific interest is the variability of coating deposition between, for instance, the face of the gear tooth and the root. This information is especially valuable in later coating development where further application-specific optimization of coating properties is needed. Measurements of surface roughness and profile, residual stress analysis, and micro-hardness are among the methods used in this phase. Examples of characterization results are shown in figure 1.

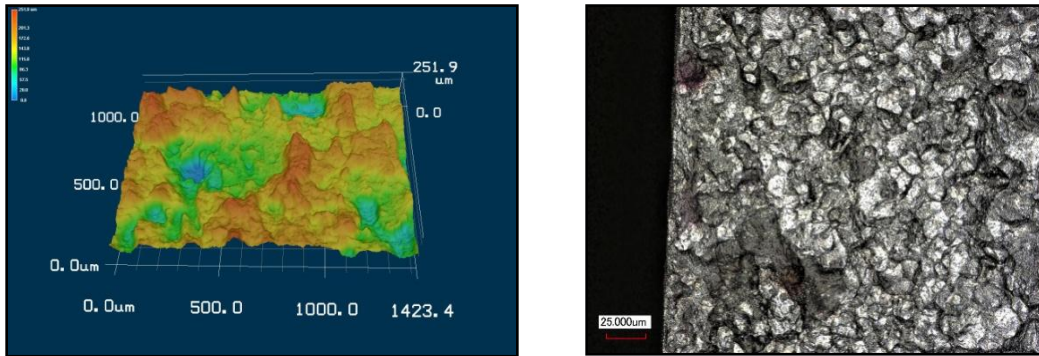

Figure 1. Typical confocal laser microscope images showing surface texture and fracture surface in a gear specimen.

Following experimental testing, various specimens are examined using a variety of methods such as metallography, chemical analysis, fractography, and hardness measurements. These methods assist in identifying the origins of failure and morphology, and determining any mechanical, metallographic, or visual changes that occur in the failure process. As with pre-test characterization, these results ultimately aid in developing improved treatments through a better understanding of the failure mechanisms.

### 3.3 Task 3: Basic Research to Characterize Friction, Wear, Efficiency, Loss-of-oil, and Lubricant Compatibility Behavior of Engineered Surfaces

A basic research effort is a necessary part of the technical approach to assess fundamental mechanisms of friction, wear, and lubrication for the engineered and coated surfaces of interest. This fundamental research mitigates technical risk by exposing relevant physical mechanisms and provides input for predictive models to optimize the engineered system. This task encompasses several methods to measure and model the efficiency as well as wear and scuffing performance of various engineered surfaces. In this effort, both AISI 5120 and AISI 9310 steel specimens are used to generate results applicable to both ground vehicle and rotorcraft transmissions. The surfaces tested include an as-ground surface finish in addition to two different superfinish treatments and a NiB coating.

The first superfinish process achieves a roughness of 2–4  $\mu\text{in } R_a$ , which will be tested on both the 5120 and 9310 specimens. The second method can achieve a 0.5–1  $\mu\text{in } R_a$  and will only be tested on the 9310 specimens targeted for aerospace applications. The NiB coating is only applied to 5120 gear steel since the substrate is not expected to significantly affect results in the initial screening experiments. The oil used for testing includes 80W90 for 5120 specimens similar to an axle lubricant and a MIL-PRF-23699 turbine oil for 9310 specimens. NiB-coated 5120 specimen tests will be run using 80W90. For all tests in this task, mating surfaces will have the same surface treatment and be of the same material.

Initial experiments will be conducted in a disk-on-roller configuration to determine friction coefficient characteristics of as-ground, superfinished, and coated specimens (figures 2 and 3). Friction measurements will be made at various rolling velocities, sliding ratios, and loads, as shown in table 1, to evaluate the mechanical power loss and heat generation in simulated gear contacts. The rolling and sliding velocity of the contact are expressed in equations 1 and 2 with the sliding ratio defined in equation 3. The measured torque,  $T$ , and load,  $W$ , will then be used to determine the coefficient of friction as shown in equation 4.

$$u_{roll} = \frac{1}{2}(u_d + u_r) \quad (1)$$

$$u_{slide} = u_r - u_d \quad (2)$$

$$SR = \frac{u_{slide}}{u_{roll}} = \frac{2(u_r - u_d)}{u_r + u_d} \quad (3)$$

$$\mu = \frac{T}{r_d W} \quad (4)$$

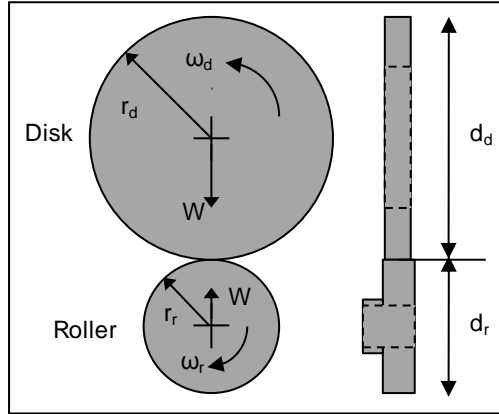

Figure 2. Disk-on-roller test setup for friction, wear, and scuffing tests.

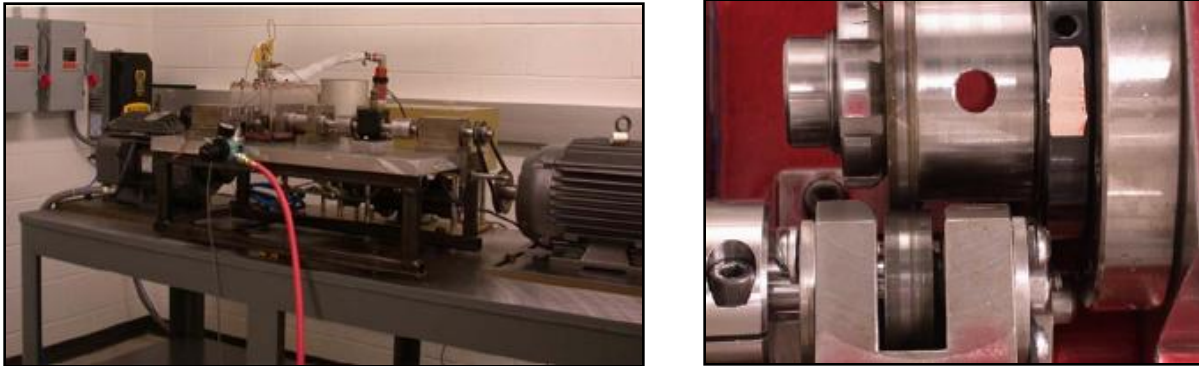

Figure 3. Disk on roller test rig (left) and specimen contact arrangement (right) for basic friction and wear characterization research (courtesy The Ohio State University).

Table 1. Disk-on-roller test matrix (5120 specimens will be tested using 80W20 oil and 9310 specimens will be tested using Aeroshell 555).

	<b>Friction Test</b>	<b>Wear Test</b>	<b>Scuffing Test</b>
Load (GPa)	1, 2	1, 2	1
Contact speed (m/s)	5, 10, 15	5, 10	5, 10
Sliding ratio	[-1,1]	TBD	-1, 1
Oil flow	Normal	Normal	Normal, Starved

Scuffing experiments will be performed on disks to assess the thermal behavior of sliding contacts under favorable and loss-of-oil conditions. This experiment will run at a specified speed with incrementally increasing load until scuffing occurs. A third set of experiments will be run on this machine to determine wear characteristics by running at constant speed and load with full fluid film for up to 30 million cycles and examining the change in the surface profile after testing. These tests will evaluate the effectiveness of the NiB coating in comparison with the ground and superfinished surfaces.

Using the traction results of the initial disc-on-roller experiments, a modeling and simulation effort will predict the mechanical efficiency of contacting surfaces with varying surface roughness and friction coefficient. The models have been developed in recent years at The Ohio State University (13–15). This effort will develop predictive tools to more rapidly identify optimal surface characteristics for increased powertrain efficiency. These models will be validated with spur gear efficiency tests.

### 3.4 Task 4: Powerplant Component Experiments: Piston Ring and Cylinder Liner Friction and Wear

Although the research effort focuses mainly on treatments for powertrain gears, a research effort was included to additionally investigate reciprocating contacts typical of piston engine components. This task is accomplished by subjecting piston rings and cylinder liners from diesel engines to reciprocating contact, using the methodology described in reference 16. The reciprocating tribometer used to conduct these experiments is shown in figure 4.

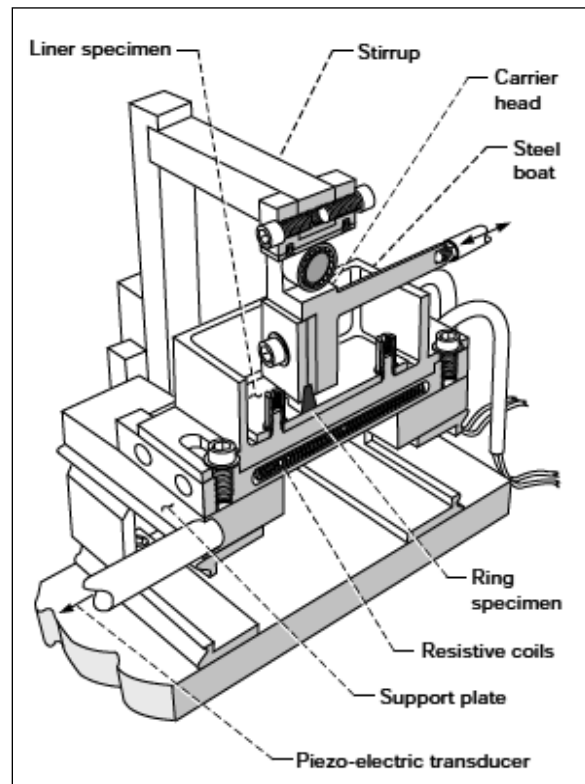

Figure 4. Diagram of reciprocating wear tribometer for coated piston ring experiments.

A baseline condition of chrome-coated ring against a cast-iron liner is run to establish typical friction coefficient and wear rate. A substitution of coated or polished rings against a cast-iron liner is the configuration of interest because it merely substitutes the surface treatment for the chrome plating, and may not have a large adverse cost effect in production.

### 3.5 Task 5: Transmission Component Experiments: Fatigue Characterization in Spur Gears

Despite potential gains in gear efficiency, surface engineering applied to power dense gears can adversely impact their usable life. High stresses and large numbers of accumulated cycles over the component life make fatigue one of the primary design concerns. With the addition of a thin tribological coating to the base gear, the interface between the coating and substrate can reduce the component life by allowing fatigue damage to initiate prematurely. Additionally, the durability of the coating itself can be a concern when hardness and grain structure are not appropriate to the loading conditions and base metal of the gear.

Similar issues are encountered with surface texturing and finishing methods, though without an interface or gradient between dissimilar materials. Generally speaking, spur gears show an improvement in fatigue life when superfinishing is employed (17–18). However, the use of surface texturing methods, a technique not considered in the scope of this work, would require careful consideration of fatigue life implications.

Because of the potential for adverse life impacts, a preliminary durability assessment is conducted on the coating using spur gears having a relatively simple geometry. Two types of fatigue failures will be examined—contact fatigue and bending fatigue. Contact fatigue arises from very large compressive stresses in the small area of contact between the two gears and is characterized by the appearance of wear, spalls, or pits. This type of fatigue is generally not catastrophic and can be sensed by appropriate instrumentation in systems that have recirculating oil. Contact fatigue experiments are conducted by subjecting coated, uncoated, and superfinished gears to varying levels of contact stress associated with varying amounts of transmitted torque. Several specimens are tested to provide a statistically significant assessment of the relative fatigue life. A diagram of a typical contact-fatigue rig is shown in figure 5 (19).

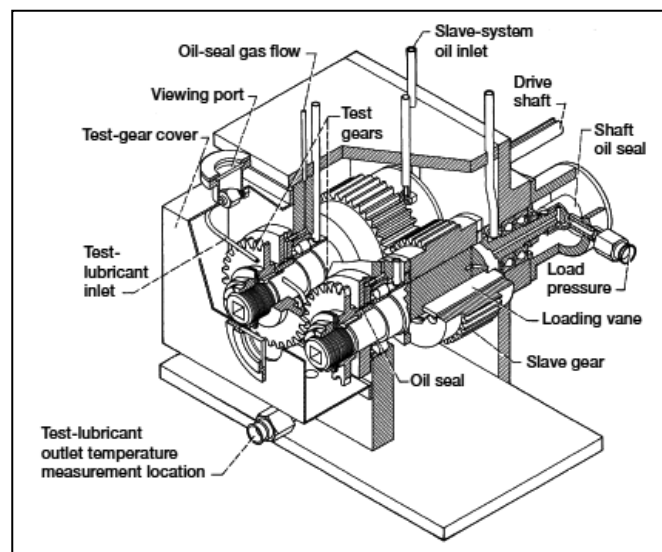

Figure 5. Diagram of gear rolling contact fatigue test rig used to investigate contact fatigue life in spur gears.

Bending fatigue generally occurs in the root of a tooth, where tensile stresses are the highest. A crack initiates and grows through the tooth until the entire gear tooth fractures off the gear. Bending fatigue failure is more likely to result in catastrophic gear failure than contact fatigue failures. Mechanical and chemical imperfections can provide initiation sites for cracks and allow these cracks to form prematurely. In these experiments, cyclic load will be applied to single gear teeth on coated, uncoated, and polished samples to determine if the surface treatments have a significant effect on bending fatigue life. Because of the stochastic and highly variable nature of fatigue failures, this task does not have sufficient scope to provide very precise life predictions or statistical confidence. Rather, it is intended as an initial screening of various failure mechanisms to mitigate technical risk in adopting a particular surface treatment. The facility used for single-tooth bending is presented in figure 6 (20).

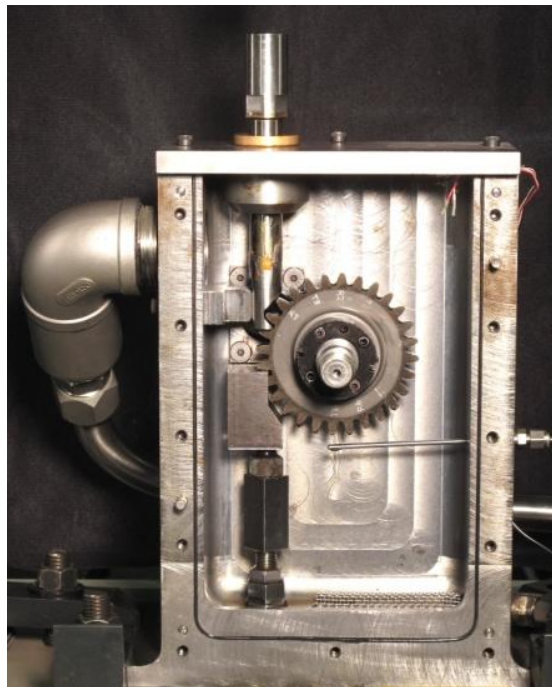

Figure 6. Image of the National Aeronautics and Space Administration (NASA)/U.S. Army Research Laboratory (ARL) single gear-tooth bending-fatigue apparatus

### **3.6 Task 6: Transmission Subsystem Experiments: Gear Efficiency in the HMMWV Rear Axle**

This task is a cost-effective and controlled series of experiments that will evaluate the improvement in gear efficiency due to the coating and superfinishing in a more realistic system-level evaluation. An actual ground vehicle gear set is selected and will be subjected to typical operating conditions while measuring input and output torque. This task starts to translate the component-level research into real-world achievable improvements.

Because of the large number of HMMWVs produced, its moderate power level, and the availability of configuration information, this platform is selected to provide the most cost-effective evaluation of system-level efficiency. To best quantify the achievable benefits of surface engineering in geared components, gearing at low speeds and high torques with higher amounts of relative sliding between gear surfaces tend to show the most benefit. For this reason, the hypoid gearing in the HMMWV axle (shown in figure 7) was selected as an appropriate subsystem on which to conduct these efficiency experiments. The geared hub has even higher torque and lower speed, but the configuration has less sliding contact.



Figure 7. Photograph of the hypoid ring and pinion gears from the M1097A2 rear axle.

A dynamometer test stand will be used to run the experiments. High accuracy torque measurements will be made at the input and outputs of the axle to determine the mechanical power lost within the axle. Various input speeds across the vehicle operating envelope, as well as at least five torque values at each speed will be run to determine steady state operating efficiency. The various speed and torque combinations will also be conducted at two different operating temperatures. Additionally, two simulated drive cycles will be run on the axles to capture transient operation and determine if steady-state efficiency measurements correlate well with real-world gains. The mission profiles are drawn from the U.S. Army Tank and Automotive Research Development and Engineering Center (TARDEC) based on test track results in combination with modeling and simulation techniques.

---

#### 4. Concluding Remarks

---

This report provides an overview of a methodology that was developed to characterize engineered surfaces for their ability to improve efficiency in vehicle powertrain gears and other components. The research tasks are designed to address TRL 2 to TRL 5, covering the basic

characterization of engineered surfaces and coatings through efficiency experiments in vehicle subsystems. Many of the methods employed here are commonly used in these types of studies, but this effort contains a comprehensive basic research portfolio aimed at screening candidate treatments and selecting promising technologies for improvements in gear efficiency.

---

## 5. References

---

1. Winkelmann, L.; El Saeed, O.; Bell, M. The Capacity of Superfinished Vehicle Components to Improve Fuel Economy. *Proceedings of the ASME 2007 International Design Engineering Technical Conferences & Computers and Information in Engineering Conference*, September 4–7, Las Vegas, NV. ASME Paper # DETC2007-34860, 2007.
2. Ehinger, R. Evaluation of Isotropic Superfinishing on a Bell Model 427 Main Rotor Gearbox. *Presented at the American Helicopter Society 63rd Annual Forum*, Virginia Beach, VA, May 1–3. American Helicopter Society International, Inc., 2007.
3. Winkelmann, W.; Michaud, M.; Sroka, G.; Swiglo, A. Impact of Isotropic Superfinishing on Contact and Bending Fatigue of Carburized Steel. *Presented at the International Off-Highway & Powerplant Congress*, Las Vegas, NV. Society of Automotive Engineers. SAE Paper #2002-01-1391, 2002.
4. Michaud, M. Metal Surface Refinement Using Dense Alumina-Based Media, US Patent #4,818,333, 1989.
5. Holland, J.; Michaud, M.; Solarno, M.; Sroka, G.; Winkelman, L. Nonabrasive Media with Accelerated Chemistry, US Patent #7,005,080, 2006.
6. Vitry, V.; Delaunois, F.; Dumortier, C. How Heat Treatment Can Give Better Properties to Electroless Nickel-Boron Coatings. *Metallurgia Italiana* **2006**, 101 (4), 2009.
7. Vitry, V.; Delaunois, F.; Dumortier, C. Nitridation Treatments to Improve the Hardness and Mechanical Properties of Electroless Nickel-Boron Deposits. *Proc. 15th IFHTSE - International Federation for Heat Treatment and Surface Engineering Congress*, p 506–511, 2006.
8. Riddle, Y.; McComas, C. E. Advances in Electroless Nickel-Boron Coatings - Improvements to Lubricity and Wear Resistance. *Presented at the 2005 Society of Automotive Engineers World Congress*, Detroit, Michigan, April 11–14. SAE Paper # 2005-01-0615, 2005.
9. Kanta, A.-F.; Vitry, V.; Delaunois, F. Effect of Thermochemical and Heat Treatments on Electroless Nickel-Boron. *Materials Letters* **2009**, 63, 2662–2665.
10. Feldstein, N.; Feldstein, M. Composite Electroless Nickel Coatings for the Gear Industry. *Gear Technology* **1997**, 14, 9–11.
11. Bedingfield, P.; Lewis, D.; Datta, P.; Gray, J.; Wells, P. Studies of Electroless Nickel-Boron Alloy Coatings. *Transactions of the Institute of Metal Finishing* **1992**, 70, 19–23.

12. Masseth, J.; Kolivand, M. Lapping and Superfinishing Effects on Hypoid Gears Surface Finish and Transmission Errors. *Proceedings of the ASME 2007 IDETC/CIE*, Las Vegas, Nevada September 4–7. ASME Paper # DETC2007-34010, American Society of Mechanical Engineers, 2007.
13. Xu, H.; Kahraman, A. Prediction of Friction-Related Power Losses of Hypoid Gear Pairs. *Proc. IMechE* **2007**, 221.
14. Xu, H.; Kahraman, A.; Anderson, N. E.; Maddock, D. G. Prediction of Mechanical Efficiency of Parallel-Axis Gear Pairs. *Trans. of the ASME, Journal of Mechanical Design*. **2007**, 129, 58–68.
15. Kolivand, M. Development of Tooth Contact and Mechanical Efficiency Models for Face-Milled and Face-Hobbed Hypoid and Spiral Bevel Gears, PhD Dissertation. The Ohio State University, 2009.
16. Radil, K. *Test Method to Evaluate Cylinder Liner Piston Ring Coatings for Advanced Heat Engines*; NASA TM 107526; National Aeronautics and Space Administration: Cleveland, OH, 1996.
17. Winkelmann, L.; Michaud, M.; Sroka, G.; Swiglo, A. Impact of Isotropic Superfinishing on Contact and Bending Fatigue of Carburized Steel SAE Paper # 2002-01-1391. Society of Automotive Engineers, 2002.
18. Krantz, T.; Cooper, C.; Townsend, D.; Hansen, B. *Increased Surface Fatigue Lives of Spur Gears by Application of a Coating*; NASA TM 2003-212463; National Aeronautics and Space Administration: Cleveland, OH, 2003.
19. Krantz, T.; Tufts, B. *Pitting and Bending Fatigue Evaluations of a New Case-Carburized Steel*; NASA/TM 2007-215009, ARL-TR-4123, 2007.
20. Stringer, D. B.; Dykas, B. D.; LaBerge, K. E.; Zakrajsek, A. J.; Handschuh, R. F. *A New High-Speed, High-Cycle, Gear-Tooth Bending Fatigue Test Capability*; NASA/TM-2011-217039, ARL-TR-5506, 2011.

---

## List of Symbols, Abbreviations, and Acronyms

---

ARL	U.S. Army Research Laboratory
EHL	elastohydrodynamic lubrication
HMMWV	high mobility multipurpose wheeled vehicle
NASA	National Aeronautics and Space Administration
NiB	nickel-boron
TARDEC	U.S. Army Tank and Automotive Research Development and Engineering Center
TRL	technology readiness level

NO. OF COPIES	ORGANIZATION
1 ELEC	ADMNSTR DEFNS TECHL INFO CTR ATTN DTIC OCP 8725 JOHN J KINGMAN RD STE 0944 FT BELVOIR VA 22060-6218
3	US ARMY RSRCH LAB ATTN IMNE ALC HRR MAIL & RECORDS MGMT ATTN RDRL CIO LL TECHL LIB ATTN RDRL CIO MT TECHL PUB ADELPHI MD 20783-1197
1	OFFICE OF THE DIRECTOR ARL VEHICLE TECHNOLOGY DIRECTORATE ATTN RDRL-VT-ODIR BELINDA SELJAN 4603 FLARE LOOP APG MD 21005
20	ARL VEHICLE TECHNOLOGY DIRECTORATE ATTN RDRL-VTP B DYKAS 4603 FLARE LOOP APG MD 21005
10	ARL RTRCRFT PRPLSN TEAM ATTN D. BLAKE STRINGER 21000 BROOKPARK RD MS 23-3 CLEVELAND, OH 44135