

<b>REPORT DOCUMENTATION PAGE</b>			<i>Form Approved</i> <i>OMB No. 0704-0188</i>		
Public reporting burden for this collection of information is estimated to average 1 hour per response, including the time for reviewing instructions, searching existing data sources, gathering and maintaining the data needed, and completing and reviewing this collection of information. Send comments regarding this burden estimate or any other aspect of this collection of information, including suggestions for reducing this burden to the Department of Defense, Washington Headquarters Services, Directorate for Information Operations and Reports (0704-0188), Jefferson Davis Highway, Suite 1204, Arlington, VA 22202-4302. Respondents should be aware that notwithstanding any other provision of law, no person shall be subject to any penalty for failing to comply with a collection of information if it does not display a currently valid OMB control number. PLEASE DO NOT RETURN YOUR FORM TO THE ABOVE ORGANIZATION.					
<b>1. REPORT DATE (DD-MM-YYYY)</b> 28 March 2013		<b>2. REPORT TYPE</b> Final		<b>3. DATES COVERED (From - To)</b>	
<b>4. TITLE AND SUBTITLE</b> Test Operations Procedure (TOP) 08-2-201 Collective Protection (ColPro) Novel Closures Testing			<b>5a. CONTRACT NUMBER</b>		
			<b>5b. GRANT NUMBER</b>		
			<b>5c. PROGRAM ELEMENT NUMBER</b>		
<b>6. AUTHOR(S)</b>			<b>5d. PROJECT NUMBER</b>		
			<b>5e. TASK NUMBER</b>		
			<b>5f. WORK UNIT NUMBER</b>		
<b>7. PERFORMING ORGANIZATION NAME(S) AND ADDRESS(ES)</b> U.S. Army Dugway Proving Ground West Desert Test Center (TEDT-DPW) Dugway, UT 84022-5000			<b>8. PERFORMING ORGANIZATION REPORT NUMBER</b> TOP 08-2-201		
<b>9. SPONSORING/MONITORING AGENCY NAME(S) AND ADDRESS(ES)</b> Range Infrastructure Division (CSTE-TM), U.S. Army Test and Evaluation Command, 2202 Aberdeen Boulevard, Aberdeen Proving Ground, MD 21005-5001			<b>10. SPONSOR/MONITOR'S ACRONYM(S)</b>		
			<b>11. SPONSOR/MONITOR'S REPORT NUMBER(S)</b>		
<b>12. DISTRIBUTION/AVAILABILITY STATEMENT</b> Distribution Statement A. Approved for public release; distribution is unlimited.					
<b>13. SUPPLEMENTARY NOTES</b> Defense Technical Information Center (DTIC), AD NO.:					
<b>14. ABSTRACT</b>  This Test Operations Procedure (TOP) provides the standard for designing and conducting tests that evaluate a novel closure's ability to provide protection against vapor contaminants. This TOP presents standard test methods for vapor challenge testing of candidate novel closures, openings, and seams intended for use in collective protection (ColPro) shelters. Testing and/or characterization will be performed using simulant vapor to measure the protective capability of the candidate novel closure. The procedures in this TOP are designed to determine the amount of chemical analyte that permeates or penetrates the candidate seam and/or closure.					
<b>15. SUBJECT TERMS</b> MINICAMS <sup>®</sup> ; Gasmet <sup>™</sup> ; solid sorbent tube; SST; challenge concentration; breakthrough concentration; real-time monitor; RTM; near real-time monitor; NRTM; simulant exposure area; SEA; total exposure dosage; TED; protection factor; PF; concentration x time; Ct					
<b>16. SECURITY CLASSIFICATION OF:</b>			<b>17. LIMITATION OF ABSTRACT SAME AS REPORT</b>	<b>18. NUMBER OF PAGES</b> 69	<b>19a. NAME OF RESPONSIBLE PERSON</b>
<b>a. REPORT</b> UNCLASSIFIED	<b>b. ABSTRACT</b> UNCLASSIFIED	<b>c. THIS PAGE</b> UNCLASSIFIED			<b>19b. TELEPHONE NUMBER (include area code)</b>

(This page is intentionally blank.)

U.S. ARMY TEST AND EVALUATION COMMAND  
TEST OPERATIONS PROCEDURE

Test Operations Procedure 08-2-201  
DTIC AD No.

28 March 2013

COLLECTIVE PROTECTION (COLPRO) NOVEL CLOSURES TESTING

	<u>Page</u>
PARAGRAPH 1. SCOPE. ....	3
1.1 Background. ....	3
1.2 Purpose. ....	3
1.3 Limitations. ....	4
2. FACILITIES AND INSTRUMENTATION. ....	5
2.1 Facilities. ....	5
2.2 Instrumentation. ....	6
2.3 Test Controls. ....	6
3. REQUIRED TEST CONDITIONS. ....	7
3.1 Test Planning. ....	7
3.2 Preparations for Test. ....	9
3.3 Safety. ....	10
3.4 QA/QC. ....	11
4. TEST PROCEDURES. ....	13
4.1 Test Method Outline. ....	13
4.2 Receipt Inspection. ....	15
4.3 Pretest Procedure. ....	18
4.4 NCTF and Subsystem Verification. ....	28
4.5 Chemical Vapor Challenge Test With Positive Pressure Differential. .	33
4.6 Chemical Vapor Challenge Test With Negative Pressure Differential. .	39
4.7 Chemical Vapor Challenge Test With Equal Pressure Differential. ....	39
5. DATA REQUIRED. ....	39
5.1 Receipt Inspection Data. ....	39
5.2 Pretest Data. ....	40
5.3 Vapor Challenge Test Data. ....	41
5.4 Data Analysis. ....	42
5.5 Primary Measure of Performance. ....	42
5.6 Replicate Testing and Computation. ....	42
5.7 Data Quality Objectives. ....	43
6. PRESENTATION OF DATA. ....	44
7. FIXTURE VERIFICATION AND VALIDATION. ....	45

Approved for public release; distribution unlimited.

TOP 08-2-201  
28 March 2013

APPENDIX	A. NOVEL CLOSURES TEST FIXTURE DESCRIPTION.....	A-1
	B. ABBREVIATIONS. ....	B-1
	C. REFERENCES. ....	C-1
	D. APPROVAL AUTHORITY.....	D-1

## 1. SCOPE.

### 1.1 Background.

a. Personnel staffing a chemical, biological, and radiological (CBR) collective protection (ColPro) shelter system must be able to fulfill their military or civil mission inside the ColPro shelter. These personnel must have confidence in the ability of any openings, closures, and pass-through ports built into a ColPro shelter to adequately impede or severely restrict the passage of chemical agent vapors into the clean or toxic-free area (TFA) of the ColPro shelter. This includes closures used in mobile and transportable shelters (both hard- and soft-walled), collectively protected vehicles, and aircraft designed to use ColPro liner enclosure systems.

b. There are ongoing efforts to improve the effectiveness and efficiency of chemical and biological (CB) protective systems for the U.S. military. Major components in the ColPro systems developed over the last 40 years are the CB protective liners for shelters and other applications, such as emergency shelters in permanent structures. These liners consist of sections of CB-impermeable material that allow a modular shelter to be assembled in varying configurations. These liner sections interface via a structural sealing mechanism such as a zipper or a zip track. Closure seals are typically used at entry/exit airlocks, vestibules, modular section interfaces, doorways, windows, and environmental control unit duct joints.

c. New closures under development in science and technology programs for future ColPro systems may include interfaces such as novel designs using zippers, hook-and-pile closures, and zip-track closures, among others. The performance of an entire closure can only be adequately assessed by testing full-sized candidate closures under controlled conditions before further acquisition and inclusion in a ColPro shelter. Only small segments or swatches of closure-seal materials can be tested using current chemical warfare agent (CWA) permeation test fixtures and methods<sup>1-4\*</sup>.

### 1.2 Purpose.

a. This Test Operations Procedure (TOP) provides the standard for preparation, planning, conduct, and reporting test results that evaluate a novel closure's ability to protect against vapor contaminants.

b. This TOP presents standard procedures for vapor challenge testing of candidate novel closures, openings, and seams intended for use in ColPro shelters. Testing and/or characterization will be performed using simulant vapor, with appropriate agent-simulant relationship (ASR) factor(s), to measure the protective capability of the candidate novel closure. The procedures herein are designed to determine the amount of chemical analyte that permeates or penetrates the candidate seam and/or closure.

c. This TOP describes test methods and parameters required for each method. However, test parameters may change depending on objectives for a particular test program. The

---

\*Superscript numbers correspond to those in Appendix C, References.

objectives for test programs can be found in the capability development document (CDD), system performance specification (SPS), or similar program documentation.

d. This TOP must be used when preparing test-specific test plans or detailed test plans (DTPs). The test procedures described in this document must be referenced and/or incorporated in the test-specific document.

(1) The DTP should describe the procedures required for operations that are specific to the test and the test parameters to be used. These may be based on factors such as the concept of operations requirements and/or threats to the ColPro shelter being tested.

(2) The test procedures described in this document must be referenced and/or incorporated into a DTP or similar document. The procedures may be modified in the DTP to accommodate unique items or materials or to satisfy testing requirements specified in the system evaluation plan (SEP) or other acquisition document. Alteration, however, will be made only after full consideration of how the changes may affect the reliability and validity of the data. These alterations, a description of the effect desired by the change, and the changes in the assessment process must be fully described in the DTP.

(3) A consideration of modifications to this TOP will include a risk assessment coordinated in advance with the organizations concerned. The assessment will address the impact of the modifications to the following test areas:

- (a) Safety.
- (b) Test conditions.
- (c) Environmental effects.
- (d) Human use.
- (e) Data quality.
- (f) Test validity.

### 1.3 Limitations.

a. The procedures in this TOP alone are not sufficient to assess the ability of ColPro items to protect the user. These procedures are designed to be used as one component in an overall assessment program evaluating the material performance, manufacturing, and system integration with other pieces of protective equipment.

b. If a comparison with previous data is planned, special caution must be taken to use the same conditions as the desired comparison test. Results obtained by using this TOP may be compared with results from other systems tested during the same experiment or from those tested previously under the same conditions. The test conditions must be the same among compared results for statistical validity.

c. The results obtained by using these test procedures cannot be correlated to the full range of battlefield conditions; however, key documents, such as the system threat assessment, can help guide prioritization in establishing the battlefield conditions that should be tested. Nonetheless, an absolute protection value cannot be determined.

d. This TOP provides guidance on test design issues and data requirements that should be enhanced by information from other documents, such as the SEP, system threat assessment, the test and evaluation master plan (TEMP), and/or the DTP. For those testing programs in which a SEP is not available or applicable, the test facility should consult with the customer and use previous documents as a guide in addition to this TOP.

e. This TOP is limited to currently approved standards and procedures. Developments in practices, equipment, and analysis may necessitate new testing procedures. Additionally, standards of performance must be adjusted as technologies advance. Test procedures and parameters listed in this TOP may require updating to accommodate new technologies in test items or in test instrumentation. Any variation to the TOP procedures must be described in the test-specific DTP.

f. This TOP is limited to chemical vapors. The TOP does not address non-chemical materials (biological or radiological) or non-vaporous materials such as aerosols or liquid.

## 2. FACILITIES AND INSTRUMENTATION.

### 2.1 Facilities.

<u>Item</u>	<u>Requirement</u>
Environmentally controlled test chamber	Serves as a containment test chamber that houses the novel closures test fixture. The chamber must be capable of providing electrical power, temperature, humidity, pressure, exhaust system, etc.
Novel closures test fixture (NCTF)	An adjustable, rectangular rigid frame and system designed to test the ability of candidate ColPro closures and/or seams to prevent penetration or permeation of a chemical into a TFA. See Paragraph 4.3 and Appendix A for a complete description.
Control booth	A facility outside of the test chamber that allows for remote operation of ancillary equipment and analytical instrumentation.

2.2 Instrumentation.

<u>Parameter</u>	<u>Measuring Device</u>	<u>Permissible Error of Measurement</u>
Challenge vapor concentration	Any analytical instrument with a measurement range covering the challenge vapor concentration and a time resolution of 60 seconds. Fourier-transform infrared (FTIR) gas analyzers, such as a Gasetm <sup>TM</sup> ** DX-Series FTIR (Gasetm Technologies Oy, Helsinki, Finland) meet the requirements.	Gasetm <sup>TM</sup> -like instruments provide a detection range from 0.5 to 5,000 mg/m <sup>3</sup> and are accurate to within ±2 percent.
Breakthrough vapor concentration	Real-time monitors (RTMs), or near RTMs (NRTMs), for monitoring low-level breakthrough concentration of chemical vapor with a time resolution of 10 minutes. MINICAMS <sup>®</sup> (a miniature, automated, continuous air-monitoring system, OI Analytical, division of OI Corporation, College Station, Texas), Gasetm <sup>TM</sup> , and ppBRAE <sup>®</sup> systems can be used for this function and meet the requirements.	Instruments must be able to detect breakthrough concentrations at levels that could cause physiological effects (e.g., miosis level) or a predetermined exposure value, as specified by the test requirement document.  MINICAMS <sup>®</sup> -like instruments have a detection range of 0.001 to 10 mg/m <sup>3</sup> , accurate to within ±25 percent.  Photoionization detection instruments have a detection range of 1.0 to 9,999 mg/m <sup>3</sup> , accurate to within ±25 percent.

2.3 Test Controls.

<u>Parameter</u>	<u>Tolerance</u> (Based on Current Instrument Capabilities)
Temperature	±2°C (±3.6°F)
Relative humidity (RH)	±5 percent
Pressure differential across the closure/seam	±0.10 inches water gauge (iwg) [0.02 pounds per square inch (psi) = 0.01 kilo Pascal (kPa)]
Sampling instrument detection range	0.001 to 10 mg/m <sup>3</sup>
Pressure-dissemination compartment	-0.15 iwg
Vapor concentration measurement	±10 percent of target challenge concentration

\*\*The use of brand names does not constitute endorsement by the Army or any other agency of the Federal Government, nor does it imply that it is best suited for its intended application.

### 3. REQUIRED TEST CONDITIONS.

#### 3.1 Test Planning.

##### 3.1.1 Experimental Design.

a. The test will be designed to facilitate data analysis using standard design-of-experiment (DoE) techniques to minimize the number of trials needed to obtain statistical validity.

b. Test criteria must be defined before testing so that the program may be designed to obtain the required information. The resulting data must be adequate to support the intended analysis and assessments.

##### 3.1.2 Simulant Selection.

Simulant selection may be conducted under the acquisition program of record to identify and verify optimal simulant(s), using applicable ASRs, based on the program's threat and performance documents. The formal simulant selection process is found in the simulant selection TOP 08-2-196<sup>5</sup>.

##### 3.1.3 Documentation.

a. During the planning phase and before and during testing, the test officer will have all pertinent documentation available, including the following:

(1) Safety release and approval from the authorizing agency [U.S. Army Test and Evaluation Command (ATEC), Aberdeen Proving Ground, Maryland] to begin testing, if required.

(2) Human Use Committee (HUC) approval or exemption and notification.

(3) Manufacturer's publications, including the current safety data sheet (SDS) for the simulant of choice.

(4) Program-specific requirements documents (such as the CDD and SPS).

(5) SEP or any other applicable evaluation plans.

(6) Safety assessment report (SAR).

(7) Test planning or execution directive.

(8) Event design plan (EDP).

(9) System support package (SSP) and SSP list (SSPL).

(10) Environmental impact assessment for life cycle (EIALC).

(11) Industrial hygiene plan (IHP).

(12) National Environmental Policy Act (NEPA) documentation for the building. This may be a record of environmental consideration (REC), environmental assessment (EA), environmental impact statement (EIS), or other NEPA documentation as required.

(13) Other documentation [e.g., DTPs, TOPs, standing operating procedures (SOPs), calibration data, system threat assessment, quality assurance/quality control (QA/QC) plans, data analysis plans], as necessary.

b. Familiarization.

(1) Potential problem areas must be identified by reviewing previous records and results of similar tests, if available.

(2) Development of DTPs requires familiarization with the applicable test planning and requirements documents such as the TEMP, SEP, EDP, CDD/capabilities production document (CPD), specifications as available and appropriate, and background information, such as references from preceding development and test phases, and similar studies which required selection of appropriate samples, methods, test sequences, facilities, and test equipment.

(3) Before developing the DTP, the following functions are required:

(a) Review of the applicable SEP, other applicable evaluation plans, and test guidance literature.

(b) Familiarization with preceding development and test phases.

(c) Consideration of data from previously conducted tests in order to avoid duplication and to reduce the scope of further testing.

(4) Familiarization with the relevant SOPs and other procedures for applicability, completeness, and adequacy will be required. These documents will be updated as required.

(5) Safety and health issues must be given prime consideration in test planning. All applicable/available health and safety documents, such as the SAR and health hazard assessments (HHAs), must be reviewed to determine if any safety or health issues require special test protocols. For any tests involving military personnel not assigned as testers, a safety release (SR) and a HUC approval are required.

c. NEPA Compliance.

(1) In compliance with NEPA, the Department of the Army (DA) requires that an EIALC be prepared and that potential environmental impacts be assessed at the earliest possible stage in the planning process for any new equipment testing.

(2) Testing at ATEC facilities must also be assessed for environmental impact.

(3) A detailed EIS will be prepared by the test center and evaluated in accordance with (IAW) the NEPA processes when the proposed action may significantly affect the environment, is environmentally controversial, or when litigation is expected based on environmental issues.

(4) A REC will be completed for the test if a review indicates that there is existing NEPA documentation in place for the action. The REC will indicate the process for consideration of environmental concerns and rationale for the conclusion.

(5) The test officer will ensure that appropriate environmental documentation has been received and understood by test personnel and participants before the test begins.

### 3.2 Preparations for Test.

Planning may require certain preliminary activities that should be included in the test plan, such as the following:

(1) Identification and Coding. Before the issuance of the test item to test personnel, the test item must be assigned a unique test item control number (TICN). TICNs can be generated during test preparation as sequential alphanumeric codes that identify the specific test item. The manufacturer's serial number(s) may be used for the TICN.

(a) The TICNs must be permanently marked or attached to the test item.

(b) The TICNs must be used to track the test item from initial receipt through all system testing and should be structured based on utility for multiple developmental tests (DTs) and operational tests (OTs), when applicable. **NOTE:** An overarching TICN assignment plan will often be developed to facilitate data integration when there are multiple test sites.

(c) A TICN database will be created and assimilated into the overall test database to permit easy access to the individual records of each test item. The TICNs will allow quick retrieval of specific data corresponding to the test item, data collection information, or test incident reports (TIRs).

(2) Medical Preparations. Medical examinations of test personnel will be required to determine physical ability to perform specified tasks. Medical examinations will be conducted before the test begins. If applicable, a medical record will be maintained on each participant.

(3) Training and Familiarization. Test personnel must be trained regarding the test items and test conditions to include the following:

(a) Description of the physical activities required during actual testing. These will be provided in a written form, through audiovisual presentation, demonstration, or a combination of these methods.

(b) Identification of appropriate test personnel and processes through which participants should report any safety or health-related issues.

(c) Types of data to be collected and relationship of data to overall success of the test program.

(d) Chemicals being used in testing and any health hazards of the chemicals.

### 3.3 Safety.

#### 3.3.1 General.

a. All test operators must read and indicate that they understand the SOP and test-specific procedures outlined in the test plan.

b. The required SDS, testing protocols, and safety procedures will be available at the test site.

c. When appropriate, the test personnel will wear required personal protective equipment (PPE).

d. Test personnel will be informed of potential safety and health hazards involved in test conduct and the precautions required to prevent accidents and over-limit exposure to the simulant used in the test.

e. Test personnel who may enter the test fixture must submit to a physical examination and must be certified by on-site medical personnel for eligibility to perform the test personnel assignments.

f. Daily safety checks and briefings will be conducted to ensure that all identified safety hazards have been addressed before testing proceeds.

g. For tests that involve carrying or lifting, test personnel and participants will be instructed in the proper lifting procedures.

#### 3.3.2 Simulant Handling.

a. Simulants must be handled with care. Tests using simulants will only be conducted IAW the approved SOPs from the testing installation and the procedures specified in the DTP. At U.S. Army Dugway Proving Ground (DPG), those SOPs are DP-0000-M-073<sup>A\*</sup> and DP-0000-M-230<sup>B</sup>.

b. The test personnel must read and understand the SDSs associated with the simulant to be used. Also, the SDS for each simulant used in testing must be posted in the test area along with the DTP, testing protocols, and safety procedures.

c. Appropriate eye and respiratory protection will be worn by personnel loading sprayers, operating vapor generators, and spraying simulant.

---

\*Superscript letters correspond to those in Appendix C, References.

### 3.3.3 Fire, Pressure, and Explosion Hazard.

- a. The test personnel must check the SDSs of any chemical for the potential of creating a fire or explosive hazard.
- b. Depending on the simulant type, concentration, and flow rate, vaporization of liquid chemicals may pose a flammability or explosion hazard. If the simulant is flammable, vaporization must be performed with care to ensure that a fire does not occur.
- c. Simulant sprayers shall not be left in a pressurized state when not in use.

### 3.4 QA/QC.

#### 3.4.1 General.

a. Each test facility's QA program will be designed to ensure that data of the required quality are obtained from each test. The data quality requirements will be established by the customer as well as by the test facility's QA/QC SOPs. At DPG, WDC-QAC-003R<sup>C</sup>, WDC-QAC-002<sup>D</sup>, WDC-ADM-009<sup>E</sup>, WDC-ADM-005<sup>F</sup>, and WDC-ADM-015<sup>G</sup> are used.

b. The quality of chamber and fixture instrument data is preserved with appropriate instrument maintenance, periodic calibration, and careful documentation procedures. Calibration will be conducted IAW the validated calibration protocol of the test facility. In the absence of a validated protocol, calibration will be conducted as recommended by the instrument manufacturer.

c. Examples of QC measures associated with data reporting are sample collection documentation, tracking and evaluation of analytical results, and comparison of results. QC measures will be detailed in the DTP and will follow the test facility's QA/QC plan.

d. Sample collection QC measures will be IAW the test facility's sampling SOPs (at DPG those SOPs are WDC-ADM-005<sup>F</sup> and WDC-QAC-002<sup>D</sup>) or as specified in the DTP. Any problems associated with a particular sample will be noted on the appropriate log sheet or data file and evaluated. All data collected will be date and time stamped to the maximum extent possible.

e. Validation checks will be performed before testing, as required, to ensure that all test instrumentation is operating properly.

f. RTMs will be checked before each trial at the testing site with appropriate calibration standards to ensure they are operating within expected tolerances and statistical control. The zero level will be checked daily to ensure that it has not been altered by electronic drift.

g. Data will be independently reviewed and authenticated, as required by the test facility or the test program.

h. All analysis calculations will be peer reviewed to ensure that random errors in transcribing data and in performing analysis are eliminated, as required by the test facility or the test program.

i. For each trial, the vapor concentration at all sample points will be measured, recorded, and plotted on a chart. Measurements throughout the trial must be within  $\pm 10$  percent of the target challenge concentration or as specified by the requirements document or DTP. **NOTE:** Accuracy within  $\pm 10$  percent is a target that is achievable with current technology. As technology allows for greater dissemination and measurement accuracy, testing targets should be adapted accordingly.

j. For each trial, the temperature and RH will be monitored, recorded, and plotted graphically. If there are temperature and RH changes between trials, exceeding the tolerances outlined in Paragraph 2.3, these changes should be noted during the trial analysis process.

k. Statistical analysis will be used to determine measurement errors and to process trial data.

#### 3.4.2 Quality Objectives for ColPro Novel Closure Testing.

In addition to the program-specific requirements, the following procedures will be followed:

a. All ColPro novel closures, samplers, sampling locations, sampler sequences (time on and time off), and raw analytical data will be labeled in a manner precluding misidentification.

b. Data and analysis files will be reviewed and verified by qualified personnel knowledgeable and familiar with the test process, as determined by the test director or the test facility's SOPs (at DPG, SOPs used are WDC-QAC-003R<sup>C</sup>, WDC-QAC-002<sup>D</sup>, WDC-ADM-009<sup>E</sup>, WDC-ADM-005<sup>F</sup>, WDC-ADM-015<sup>G</sup>, and WDC-ADM-017<sup>H</sup>).

c. The performance of each RTM must be checked daily at the testing site. Calibration or calibration verification checks should be performed for automated RTMs that collect vapor samples. TFA RTMs will be checked by injecting low-level standards at known concentrations.

d. Data Collection and Handling (Backups, Data Flow Path, etc.) detailed procedures are as follows:

(1) It is preferable to continuously record all test data with an electronic data acquisition (DAQ) system so that a complete analysis may be made of the test data. The DAQ computer system should record data from all instruments that have either a digital or analog output. Examples of these data streams are temperature, humidity, and pressure collected from an analog probe.

(2) If data are collected from sources that do not have outputs for connection to DAQ recording systems, they must be recorded on a handwritten data sheet during the test. Examples of these types of data are flow rates, start and stop times, and identification numbers from solid sorbent tubes (SSTs). Handwritten data may verify test data and serve as a backup to data recorded by DAQ systems.

#### 4. TEST PROCEDURES.

##### 4.1 Test Method Outline.

a. A receipt inspection will be conducted on the test fixture frame and components to determine if they are free of defects and can provide a hermetic seal. The detailed procedure is in Paragraph 4.2.2.a.

b. Ancillary equipment and analytical instrumentation will be inspected to document the operational status and suitability of the instrumentation. The detailed procedures are in Paragraphs 4.2.2.b and 4.2.2.c.

c. Receipt inspection will be conducted on liners and barrier liners with the embedded closures to determine if they are free of defects and can be used in testing. The detailed procedure is in Paragraph 4.2.3.

d. Setup procedures for the following listed equipment are described in Paragraph 4.3.1: NCTF, liners, barrier liners, pass-through ports, blower motors and exhaust system.

e. The setup procedures for the following listed instrumentation are described in Paragraphs 4.3.2.1 through 4.3.2.7: pressure and environmental controls, referee instrumentation, sampling instrumentation, vapor dissemination instrumentation, TFA monitoring instrumentation, and data collection instrumentation. The instrument maintenance and calibration are also discussed in Paragraph 4.3.2.7.

f. The verification procedures for the operation of the NCTF and its subsystems are described in Paragraphs 4.4.1 through 4.4.4.

g. The chemical vapor challenge test with positive, negative, and equal pressure differential are discussed in Paragraphs 4.5 through 4.7.

##### 4.1.1 Significance and Use.

a. The data collected from the receipt inspection trial will allow the tester to determine whether the received test material and instrumentation are fully functional and ready for testing.

b. Data collected from the pressurization subsystem verification trials (Paragraph 4.4.1) will be used to determine whether the subsystem is capable of maintaining the required pressurized conditions and still maintain containment of any simulant vapors.

c. Data collected from the dissemination subsystem verification trials (Paragraph 4.4.2) will be used to determine whether the dissemination subsystem is capable of disseminating each simulant in a controlled amount, at a controlled rate of release, and maintained at the target concentration for a specified period of time.

d. The data collected from the permeability of barrier liner verification trials (Paragraph 4.4.3) will be used to determine whether the barrier liner is impermeable to the simulant

vapors to be used in the trial by verifying that the barrier wall is properly seated and sealed around the edges where it is clamped into the NCTF liner.

e. The data collected from the controlled release verification trials (Paragraph 4.4.4) will be used to confirm that all subsystems are functioning properly and communicating should any breakthrough occur.

f. The data collected from the positive, negative, and equal pressure differential chemical vapor challenge tests (Paragraphs 4.5 through 4.7, respectively) will be used to identify any potential limitations of and to fully confirm the protective capability of the candidate closures.

#### 4.1.2 Interferences.

a. Test methods are only intended to test a candidate closure, which is a single component of a ColPro shelter. The test methods are not intended to describe procedures for testing or characterizing the performance of an entire ColPro shelter.

b. Test methods are designed to test single-candidate novel closures, not the integrity of small compartments such as airlocks or similar combinations of two or more closures.

c. It is possible that trial duration and/or test conditions may not replicate all mission profiles. Candidate closures that successfully pass one set of test conditions replicating one mission profile may not be appropriate or usable for other mission profiles. Careful test planning is necessary.

d. The NCTF is designed to test candidate closures in a non-operational environment (e.g., the candidate closure will not be repeatedly closed and opened during testing). Results from this test method may be different when personnel and/or materiel are moved through the novel closure.

e. Breakthrough can occur either through the fabric or material of construction or the through the closure itself. To differentiate between these two sources of breakthrough, known simulant permeation curves, acquired through swatch testing for each material, will be needed before full and complete evaluation of the candidate closure.

(1) For any observed breakthrough before a material's known permeation time, it is assumed that such breakthrough is through the closure and not through the material.

(2) For any observed breakthrough after the material's known permeation time, it may indicate a breakthrough occurred either through the closure or through the material of construction. The contribution to overall failure from these two sources can be evaluated by knowing the rate of permeation and the breakthrough times of the material of construction.

f. Data collected from using this test method may not be readily compared with swatch data because of the lack of stringent controls on the temperature and humidity conditions that are typically used in swatch testing. Care must be exercised when comparing data with different temperature, humidity, and pressure differential conditions. **NOTE:** In order to compare the barrier swatch test data with the data collected using this test method, a positive control test is

recommended to determine the permeation curve of the barrier material. The permeation curve may help determine whether the breakthrough is caused by the barrier material or the closure. Matching the NCTF environmental control to those used in swatch level testing may also be used to help compare the two types of data.

g. The NCTF is not insulated. Testing is typically done by placing the NCTF indoors and within a test chamber at the normal building temperature control (roughly 20 to 25°C) without any additional control mechanisms. If variable temperature and/or humidity conditions are desired, the test chamber must be changed to the desired temperature and/or humidity conditions.

#### 4.1.3 Apparatus.

a. The term apparatus may be used to cover equipment and analytical instrumentation used in conducting testing and sampling.

b. Instruments that may be used while conducting these tests are listed in Paragraphs 2.2 and 4.3.2.

#### 4.1.4 Hazards.

a. Identified safety hazards include those associated with using chemicals during testing that may be hazardous. All test plans should contain a safety section identifying and addressing all safety concerns IAW the composite risk management guidelines of DA Pamphlet (PAM) 385-30<sup>6</sup>. The safety section of the test plan should be coordinated with the test site's safety office.

b. Additional information on possible hazards and safety procedures are provided in Paragraph 3.3.

#### 4.1.5 Calibration and Standards.

Calibration procedures for the instrumentation that will be used during testing are discussed in Paragraph 4.3.2.7.

### 4.2 Receipt Inspection.

#### 4.2.1 General Requirements.

a. Packaging will be examined for indications of damage to the individual items that will be used for testing. Any damage to packaging will be recorded in a logbook, and photographs will be taken to visually document damage.

b. After unpacking, each item will be visually examined to determine if it has sustained damage during shipment. Any damage will be recorded in a logbook, and photographs will be taken to visually document any damage.

c. Based on inspection results, items will be either approved for use or rejected.

d. Photographic and text records will be established for any unacceptable items. Unacceptable items will be replaced with acceptable items.

#### 4.2.2 Inspection of the Test Fixture, Ancillary Equipment, and Instruments.

##### a. Test Fixture Inspection.

(1) The test fixture and related hardware must be complete and visually free of defects, able to provide a hermetic seal, and able to be used in testing.

(2) The fixture frame will be visually inspected daily, before testing, for damage, completeness, warping or bending, and other defects.

(3) The inspection results will be recorded in a logbook. Photographs will be taken to visually document any damage.

(4) The damaged or loose parts of the fixture will be repaired or replaced before test setup.

##### b. Ancillary Equipment Inspection.

(1) Ancillary equipment to support the NCTF must be technically operational, suitable, and ready for testing.

(2) The blower motors, dampers, and ducting will be visually inspected for damage, operability, and other defects.

(3) The blower motors will be powered up to test for functionality and ability to create necessary pressure conditions inside the NCTF compartments.

(4) The inspection results will be recorded in a logbook, and photographs will be taken to visually document any damage.

(5) The damaged or inoperable equipment will be repaired or replaced before test setup.

(6) Operators will verify that ancillary equipment can be remotely operated and monitored from inside a control booth located outside the test fixture.

##### c. Test Instrumentation Inspection.

(1) Analytical instrumentation to support the NCTF must be technically operational, suitable, and ready for testing.

(2) A visual inspection for any physical damage will be performed upon receipt of the instruments for test trials, and any discrepancy will be reported.

(3) Instruments will be initialized and inspected for operational status IAW their respective operational manuals.

(a) Operators will verify that instruments can be remotely operated and monitored from inside a control booth located outside the test fixture.

(b) Operators will verify the receipt of data output from the pressure, temperature, humidity, referee, and sampling instrumentation.

(4) An instrument logbook will be used to track the record of installation, calibration, maintenance, and any instrumental failures.

(5) Before beginning each test, the test officer must verify that all calibrations are current and record the calibration date.

#### 4.2.3 Receipt Inspection of Liners and Barrier Liners With Closures.

a. The liners and barrier liners with the embedded closure must be free of defects.

b. Packages of liners and barrier liners with closures will be unpacked, inventoried, and inspected upon receipt and checked against the equipment parts list for comparison with the purchasing inventory. Any discrepancies will be documented. **NOTE:** Liners and barrier liners with closures must be in new condition. An exception to the new condition requirement is if a barrier wall with a candidate novel closure is presented for follow-on testing in the NCTF after operational testing.

c. Liners and barrier liners with closures should be of single construction (excepting the embedded closure) and free of defects.

d. Liners and barrier liners will be examined for rips, tears, incomplete seams, and other defects.

e. The operational status of closures will be verified.

f. Any material deterioration or damage will be recorded in a logbook and photographs will be taken to visually document any damage.

g. If the items appear to have defects or missing components that would prevent testing, the item will be replaced.

#### 4.2.4 Industrial Chemical or Simulant.

a. Any chemical that can provide sufficient vapors at the desired concentration can be used in support of testing described in this TOP. This includes toxic industrial chemicals (TICs) and chemicals that are traditionally used as simulants for chemical agents.

b. The industrial chemical or simulant will be obtained from a chemical supply source and ordered with the desired purity.

c. Acceptable purity and applicable ASR factors will be determined by the test requirements.

#### 4.3 Pretest Procedure.

##### 4.3.1 Test Fixture, Liner, and Ancillary Component Description and Installation Procedures.

###### 4.3.1.1 NCTF, Liner, and Ancillary Component Description.

a. The entire system, consisting of the NCTF, ancillary equipment, and instruments, is shown in Figures A-1 and A-2. The instrument and equipment placement for some items (for example, mixing fans) is only suggestive and depends on the needs of the test.

b. Figure 1 also provides an overview and a basic floor plan diagram of the NCTF and ancillary equipment and instruments.

c. Additional descriptions, illustrations, and diagrams of the fixture, the liner, and the ancillary components are in Appendix A.

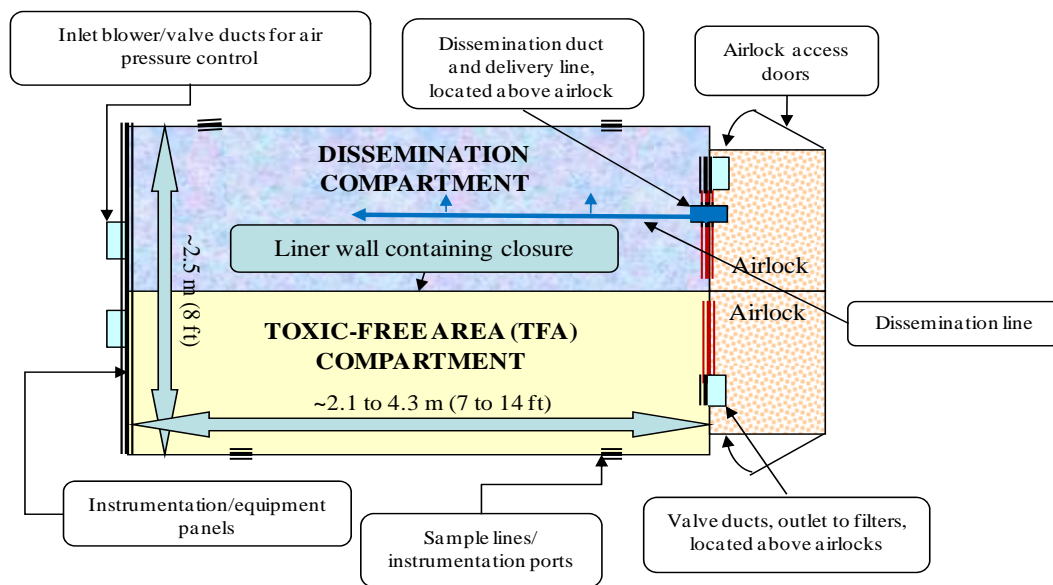

**NOTE:** Test fixtures should be of like design and configuration to ensure uniformity in testing across the test community. Although test fixtures will be of similar size and configuration, there may be some variation of equipment/instrumentation between testing locations. This is permitted as long as performance requirements described elsewhere in this document are met.

Figure 1. Floor plan showing the top view of the NCTF.

#### 4.3.1.2 NCTF and Liner Installation.

a. The test fixture, liner and ancillary equipment will be erected to the configuration described in Appendix A.

(1) The test fixture will be erected. The airlocks will be attached to one end.

(2) The two C-shaped liners will be installed. This is done by placing the edge of the liner along the fixture frame and securing a clamping plate to the frame.

(3) A barrier liner with the candidate closure will be securely fastened into the test fixture liner.

b. The test fixture must be set up with all ancillary equipment so that it can be remotely operated and monitored from a control booth outside the test chamber. This includes data output from pressure, temperature, humidity probe, referee, and sampling instrumentation.

c. The use of still photography to document the assembly of the fixture by stages and the arrangement and location of all ancillary components, such as blower motors, exhaust fans, pass-through ports, etc is recommended.

(1) Still photography may be used to identify the location of all equipment, instruments, and sampling locations in the dissemination chamber and TFA.

(2) Video may be recorded as necessary to document fixture assembly and disassembly of the fixture.

#### 4.3.1.3 Blower Motor and Exhaust Installation and Setup Procedures.

a. A blower motor will be installed for each compartment.

(1) The blower motor for the dissemination compartment will be oriented so that the desired negative or positive pressure, relative to the chamber inside the dissemination compartment, will be created.

(2) The blower motor for the TFA compartment will be oriented so that the desired negative or positive pressure inside the TFA will be created.

b. The environmental monitors and the electronic and computer-controlled systems (e.g., data collection system) will be installed.

c. The blower motor system will be considered test ready when the required differential pressure is achieved across the novel closure-embedded liner. For example, a pressure of  $0.45 \pm 0.10$  iwg in the TFA and  $-0.15 \pm 0.10$  iwg in the dissemination compartment, relative to the test chamber pressure, meets this requirement for a positive pressure test.

d. To prevent re-entrainment of chemical vapors back into the fixture, ducting will be installed from the exhaust ports to the chamber filter system to capture exhausted vapors.

#### 4.3.2 Instrumentation Setup and Calibration.

##### 4.3.2.1 Environmental Control and Measurement Probe Installation and Setup Procedures.

a. All temperature, humidity, and pressure measurement probes must be capable of measurements at 60-second intervals. The measurement recording system must be capable of digitally storing the data in a format compatible with commonly used spreadsheets or statistical and data analysis software. **NOTE:** It is unnecessary to monitor or record the temperature, humidity, and pressure inside the airlocks.

##### b. Temperature Measurement Probes.

(1) The NCTF is not insulated. Temperature conditions will be controlled by test chamber operating conditions. No effort will be made to control the temperature inside the NCTF separate from the test chamber. It is assumed that the temperature inside the NCTF will be the same as and homogeneous with the test chamber temperature. **NOTE:** Conditions from prior testing<sup>7</sup> have shown that there is an average of 7 percent difference in the temperature between compartments. Temperatures inside the dissemination compartment may be higher than temperatures inside the TFA during testing; this can be attributed to heated vapor dissemination lines. Liquid in the simulant container may be heated as high as 60°C (140°F). Continuous influx of hot vapor may elevate the temperature inside the dissemination compartment.

(2) Temperature probes will be installed in each fixture compartment. The temperature will be measured and digitally recorded inside the chamber and each of the two main NCTF compartments.

##### c. Humidity Measurement Probes.

(1) Humidity conditions inside the test fixture will be the same as the test chamber operating conditions. No effort will be made to control the humidity inside the NCTF separate from the chamber. It is assumed that the humidity inside the NCTF will be the same as and homogeneous with the chamber humidity. **NOTE:** Conditions from prior testing<sup>7</sup> have shown that there is an average of 10 percent difference in the RH between compartments.

(2) Humidity probes (or temperature/humidity probes) will be installed. The RH will be measured and digitally recorded inside the test chamber and within each of the two NCTF compartments.

##### d. Pressure Measurement Probes.

(1) The pressure inside each compartment must be monitored throughout testing. Pressure monitors should be located inside and outside the NCTF. These data will be used to calculate the differential pressure and verify that required operational conditions can be created and maintained inside each compartment of the NCTF.

(2) The target pressures and resultant differential pressures for each compartment will be based upon the type of test to be conducted (positive pressure, negative pressure, or equal

pressure). The pressure from all locations will be measured, digitally recorded, and monitored using software, such as Laboratory Virtual Instrumentation Engineering Workbench (LabVIEW<sup>®</sup>, National Instruments, Austin, Texas).

(3) Differential pressures can be calculated from the pressures measured within each compartment and outside the NCTF within the test chamber.

(4) A feedback loop from the pressure probes will be used to control blower motors and exhaust fans, which will allow continuous and real-time pressure adjustments in each compartment.

#### 4.3.2.2 Referee Instrumentation.

a. Sampling ports from referee instruments should be located in the dissemination compartment at locations that yield a spatial synopsis of the vapor concentration. The referee instruments must be calibrated to analyze vapor concentration levels over the range required by the test program. The range may be as large as 0.5 to 5,000 mg/m<sup>3</sup>. **NOTE:** It is recommended that referee instruments must have a data-recording time of no more than 1 minute. This will permit near real-time (NRT) adjustment of the challenge vapor concentration.

b. The referee instrumentation should be located outside the fixture compartments with sampling lines extended into the NCTF. Locating the referee instrument inside the dissemination compartment may alter a uniform distribution of the challenge concentration, such as from an instrument's internal cooling fan. The instrumentation should also be connected to the digital data collection system.

c. Sampling lines should be at various locations inside a compartment to determine the homogeneity of the challenge vapor concentration. The sampling lines should be equally spaced, with respect to vertical and horizontal separation, throughout the dissemination compartment. **NOTE:** The Gasmeter<sup>™</sup> DX-4000 FTIR gas analyzer was used during previous testing<sup>7</sup> and has met the requirements needed for referee instruments. Figure 2 shows examples of instrumentation sampling line locations.

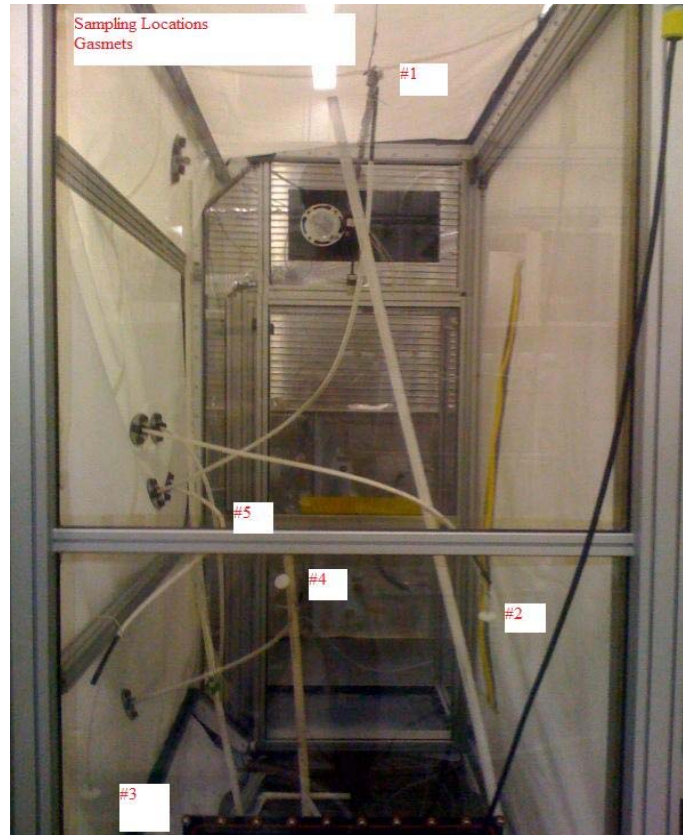

Figure 2. Photograph of referee sampling line locations in the dissemination compartment.

#### 4.3.2.3 Sampling Instrumentation Installation and Setup Procedures.

a. Sampling instruments should be set up in the TFA. The instruments must have a detection range of at least  $0.001$  to  $10 \text{ mg/m}^3$  to allow early detection of extremely low amounts of simulants that may have permeated the closure.

b. Possible instruments include NRT detectors, point detectors, and cumulative dose samplers. Suggested instrument placement is shown Figure 3. All analytical instrumentation used for measuring simulant vapor concentration in the TFA and in the dissemination compartment should be categorized according to their response/analysis time.



Figure 3. Photograph of sampling line locations in the Toxic Free Area (TFA) compartment; probes were connected to the MINICAMS®.

c. Examples of analytical instruments that may be used in testing include:

(1) Vapor samplers such as MINICAMS®, which is a miniature, automated, continuous air-monitoring system based on gas chromatography (GC) technology for separating and identifying chemical vapors. **NOTE:** Ancillary equipment such as compressed gas cylinders will require placement of the MINICAMS® outside the NCTF and the use of heated sample lines from the sampling location to the MINICAMS®. Vapor samplers based on GC technology have a time-delayed response between 5- and 10 minutes and are considered to be NRT detectors.

(2) Ion mobility spectrometry (IMS)-based samplers, such as the Building Protection (BP)-IMS and the Multicapillary-Column (MCC)-IMS (G.A.S., Dortmund, Germany), are low-level [on the parts-per-billion (ppb) level] detectors with fast response times of less than 1 minute. These instruments can work in a variety of humidity conditions and do not need ancillary equipment, such as compressed gas cylinders.

(3) Point detectors, such as a ppbRAE<sup>®</sup> (RAE Systems, San Jose, California), are non-selective handheld volatile organic compound (VOC) monitors that use a photoionization detector (PID) to provide ppb detection. These vapor samplers have response times of a few seconds.

(4) Cumulative dose samplers, such as SSTs, sample vapors for a specified period of time (generally intervals of 1 hour or longer). Cumulative sampling devices do not provide time-dependent data and are analyzed after the trial is completed, sometimes several days later. Cumulative sampling devices can only be used in the TFA and never used in the dissemination compartment.

d. The following are suggested sampling locations around the closure in the TFA compartment:

(1) The sampling instrumentation should be placed at sampling points at or near possible stress points or weak spots of the closure.

(2) For dissemination subsystem verification trials (Paragraph 4.4.2), sampling lines should be installed within 0.3 m [1.0 ft] of each corner of the blank barrier liners.

e. Sampling probes should be installed as close as possible to the embedded closure as practical to avoid any undue dilution effects in the TFA.

f. Controlled release testing must be conducted to demonstrate that sampling instrumentation can detect simulant in the fixture (Paragraph 4.4.4).

#### 4.3.2.4 Vapor Dissemination Instrumentation Installation and Setup Procedures.

a. All vapor dissemination instrumentation must be either NRT detectors or point detectors in order to immediately determine when the target challenge vapor concentration is reached. Cumulative dose samplers, such as SSTs, should not be used to measure the challenge vapor concentration.

b. At least two, and preferably five, analytical instruments should be used to measure the homogeneity of the challenge vapor concentration. The analytical instruments should be equally spaced throughout the dissemination compartment. **NOTE:** Determining the homogeneity of a simulant concentration by comparing responses among NRT and point detectors is not recommended. It is acceptable to use multiple types of instruments if the data are compared only across the same types of instruments.

c. For ease of operation, the dissemination equipment should be maintained outside the NCTF and plumbed through the fixture wall to disseminate the simulant. This setup will also help avoid any adverse effects the equipment may have by impeding airflow throughout the dissemination compartment. Any adverse effects that may be caused by a leak in the dissemination lines or simulant container may be avoided by maintaining the dissemination equipment outside the NCTF.

d. The dissemination equipment should also have an outlet that feeds the vapors through a pass-through port into the dissemination compartment. A manifold should be located inside the dissemination compartment to feed the vapors to various locations inside the compartment.

(1) Simulants that have a high boiling point or low vapor pressure may condense in unheated lines. Therefore, the disseminator and dissemination lines should be wrapped with heat tape to ensure that the simulant vapors do not condense in the transport lines.

(2) At least two, small portable fans should be placed inside the dissemination compartment to ensure homogeneity of simulant vapors throughout the compartment. The fans should be oriented to blow air parallel to the barrier liner and to prevent simulant vapors being blown directly onto the barrier liner. The fans must be properly secured to avoid incidental movement. Mixing fans must not be placed inside the TFA.

e. The dissemination system must be able to maintain the concentration and challenge time period as specified in the DTP. The design and type of dissemination system depends on the type of simulant being used, whether it is liquid or gas.

f. For disseminating a liquid simulant, an appropriate dissemination vessel, such as an impinger type, may be used.

(1) A bank of remotely operated mass-flow controllers will be arranged in parallel and placed between the blower motor and the inlet port of the dissemination vessel.

(2) During liquid simulant dissemination, a blower motor should be connected to the bank of mass-flow controllers. The lines from the controllers will be connected into the disseminator containing liquid simulant. The blower will force simulant-saturated air through the stainless steel line from the simulant container and through the manifold inside the dissemination compartment.

g. For disseminating a gas simulant, a high-pressure cylinder of simulant will be connected to a line that transports the gas into the dissemination compartment.

(1) Most gas flow regulators cannot be operated remotely; therefore, a remotely operated solenoid should be installed inline between the regulator and the pass-through port.

(2) Lines will also be attached to a manifold inside the dissemination compartment to distribute simulant throughout the compartment.

#### 4.3.2.5 TFA Monitoring Instrumentation.

a. Analytical instruments located in the TFA must have a detection range from 0.001 to 10 mg/m<sup>3</sup>. This range will permit testers and evaluators to ascertain the amount of breakthrough without undue saturation of the instruments.

b. TFA monitoring instruments may consist of sets of NRT point detectors or cumulative sampling devices.

c. TFA monitoring instrumentation and/or probes must be located as close to the novel closure as practical [approximately 2 to 5 cm (0.79 to 1.97 in)] and equally spaced around the novel closure.

(1) Close placement of sampling devices/probes to the closure should prevent dilution of any detected simulant vapors from the air volume inside the TFA.

(2) At least one set of TFA monitoring instruments must be placed at heights [1.5 to 2.0 m (4.92 to 6.56 ft)] to correspond with the breathing heights of personnel, as is practical with the test design.

(3) Other TFA monitoring instruments should be placed where challenge simulant breakthrough is likely to occur, such as possible stress points, tight curves, or weak spots.

d. There must be at least four sampling locations around the novel closure.

(1) Doorway closures must have sampling devices at each of the two sides and two on the top of the doorway.

(2) For windows or pass-through ports, one sampling location should be on each of the four sides.

(3) Should logistical considerations permit it, and if sufficient analytical instrumentation is available, sampling locations may be located within a maximum 0.61-m (2-ft) separation around the candidate novel closure.

e. Additional sampling locations may be selected to suit the needs of a particular test. These may include stress points, tight curves, loosely stitched seams, etc.

#### 4.3.2.6 Data Collection Installation and Setup Procedures.

a. All instrumentation devices should be set to record data every 60 seconds. This includes the temperature, RH, and pressure probes in each compartment, mass-flow controllers for the dissemination equipment, and the referee instrumentation.

b. Laboratory recording software, such as LabVIEW<sup>®</sup>, will be used to query each probe and digitally record the data. **NOTE:** The laboratory recording software system should be capable of digitally storing the data in a comma-separated value (CSV) format, which is compatible with commonly used statistical and data analysis software. This process should synchronize the data with a date and time stamp.

c. Monitoring and recording of the environmental conditions (temperature, humidity, and pressure) inside the airlocks will not be performed. These data would provide no benefit for the interpretation of the performance test data.

d. All clocks and time stamps for all data collection devices must be synchronized. Synchronized equipment must include, but not be limited to, all referee instruments, all sampling

instruments, and remotely operated dissemination equipment (such as pressure, temperature, and humidity sensors, etc.).

e. Still photographs should be taken to document the relative location of the installed closure and the locations of the sampling instrumentation in the TFA with respect to the closure. When possible, photograph scales or rulers will be included to show relative dimensions and distances.

#### 4.3.2.7 Instrument Maintenance and Calibration.

a. Equipment and instrument calibrations are necessary to ensure quality data are collected, and calibrations should be verified frequently in order to preserve the integrity of the data. To perform an accurate and reproducible test, all instrumentation and measurement devices associated with the test must be calibrated locally.

b. Requirements for instrumentation calibration should be based on procedures outlined in the instrument's technical manuals, be appropriate for existing environmental conditions, and include routine tests for operability.

c. The calibration schedule will depend on the instrument's calibration stability over time, the time needed to conduct the calibration, and the ease of calibrating an instrument in place.

(1) All instruments used for testing must be calibrated or certified before use IAW the test facility's SOPs (at DPG, SOPs used are DP-0000-D-216<sup>I</sup>, WDC-CL-052R<sup>J</sup>, WDC-ANA-032<sup>K</sup>, WDC-WIN-009<sup>L</sup>, WDC-ANA-039<sup>M</sup>, WDC-ANA-034<sup>N</sup>, and WDC-CL-044R<sup>O</sup>), as recommended by the manufacturers' requirements, and/or IAW any other specified test facility calibration program requirements. This will include scheduled and onsite calibration as the situation requires. Site requirements for instrumentation should reference procedures outlined in the technical manuals (TMs)/operator manuals (OMs) and should be appropriate for existing environmental conditions. All instrumentation should be routinely tested for operability.

(2) Calibration procedures should meet the guidelines of American National Standards Institute National Conference of Standards Laboratories (ANSI NCSL) Z540-3<sup>8</sup>, or International Organization for Standardization (ISO) 10012:2003<sup>9</sup>.

(3) In the absence of any site-established procedures, those outlined in the following documents will be used: U.S. Army Regulation Technical Bulletin (TB) 750-25<sup>10</sup>, U.S. Marine Corps Technical Instruction (TI) 4733-OD/1<sup>11</sup>, U.S. Air Force Technical Order (TO) 00-20-14<sup>12</sup>.

**NOTE:** Available instrumentation may not be able to detect to toxicity levels in NRT. This is highly dependent on simulant selection, type of detection instrumentation, and NRT sampling cycle time.

d. Instruments, such as flow meters; mass-flow controllers; and pressure, temperature, and RH probes, cannot be calibrated in place. These instruments should have a valid calibration certificate that covers the anticipated testing period. A daily verification of the calibration is not required.

e. Records of calibration and repair will be maintained for each instrument. National Institute of Standards and Technology (NIST) traceable sources should be used to the greatest extent possible.

#### 4.4 NCTF and Subsystem Verification.

Before conducting trials of record and collecting performance data on candidate novel closures, the operation of the NCTF and its subsystems must be verified. The following subsystem verification tests must be independently conducted:

- a. Pressurization and environmental control subsystem.
- b. Dissemination subsystem.
- c. Permeability of barrier wall.
- d. Controlled release verification.

##### 4.4.1 Pressurization and Environmental Control Subsystem Verification Procedures.

a. The pressurization subsystem and liner are designed to maintain required pressurized conditions and still maintain containment of any simulant vapors. The pressurization subsystem must be verified by implementing the following steps:

(1) The test fixture and ancillary equipment will be assembled as described in Paragraph 4.3.1 and Appendix A.

(2) The pressurization system, blower motors, etc., will be installed IAW manufacturer's instructions and Paragraph 4.3.1.3. The blower motor for the dissemination compartment must be connected to the exhaust port of the compartment so that a negative pressure may be generated. The blower motor installed for the TFA must be capable of operating in either a positive pressure or negative pressure mode.

(3) The two C-shaped liners and a blank barrier wall will be installed. The barrier wall must be of single construction without any holes or closures embedded in it.

(4) Additional beams will be installed in the dissemination compartment (and the TFA as needed) to prevent the C-shaped liners from collapsing under reduced pressure. **NOTE:** The seal around the C-shaped liners and barrier liner may be enhanced by placing duct tape along the edges of the clamping plates that secure the barrier liner to the test fixture.

b. The temperature, humidity, and pressure probes will be installed outside the test fixture, inside the dissemination compartment, and inside the TFA IAW Paragraphs 4.3.2.1 and 4.3.2.2.

(1) The environmental probes will be connected to a computer (remotely, wirelessly, or hard-wired) to digitally record all data at prescribed intervals.

(2) The temperature, humidity, and pressure probes will be activated to verify that the probes are measuring and digitally recording the data using laboratory recording software and that the data contain a date and time stamp.

c. The pressurization system and blower motors, etc., for the dissemination compartment will be activated and adjusted to maintain a pressure of -0.15 iwg relative to the pressure in the test chamber.

(1) The negative pressure ensures that any air leakage results in air movement from the chamber into the dissemination compartment. **NOTE:** A positive pressure inside the dissemination compartment would cause any air leakage (and possibly simulant vapors) to move from the dissemination compartment into the chamber, which could cause elevated background readings in the chamber and TFA.

(2) The pressure to the blower motors for the TFA will be adjusted as required for testing.

d. The operators will verify that the pressurization subsystem is functioning properly and in an acceptable state when the following pressure differentials are achieved:

(1) Pressure in the dissemination compartment can be maintained at -0.15 iwg relative to the chamber, and the pressure in the TFA compartment can be maintained at 0.45 iwg relative to the chamber. This results in a pressure differential across the barrier liner of 0.60 iwg. These conditions must be maintained for a period of 2 hours. This condition will be required for positive-pressure tests.

(2) Pressure in the dissemination compartment can be maintained at -0.15 iwg relative to the chamber, and the pressure in the TFA compartment can be maintained at -0.25 iwg relative to the chamber. This results in a pressure differential across the barrier liner of -0.10 iwg. These conditions must be maintained for a period of 2 hours. This condition is necessary for the negative pressure tests.

(3) Pressure in the TFA and the dissemination compartment can be maintained at -0.15 iwg relative to the chamber pressure. This condition will be comparable to what is necessary for the equal pressure test mode.

e. To be deemed acceptable, the pressurization subsystem must be capable of maintaining the required pressures within  $\pm 0.05$  iwg of the target value as determined by SPS, CDD, and/or other program documentation. The pressurization subsystem must maintain the conditions for a period of time corresponding to the planned time length of each trial plus any additional preparatory time for each trial. For example, if it takes 45 minutes to prepare for a trial, and the trial will be 6 hours in duration, then these pressurization conditions must be sustained for at least 6 hours + 45 minutes.

#### 4.4.2 Dissemination Subsystem Verification Process.

a. The dissemination subsystem must be capable of disseminating each simulant in a controlled amount, at a controlled rate of release, and maintained at the target concentration for a specified period of time. A large number of dissemination subsystems can meet these requirements. However, the dissemination subsystem must function to the specifications described in Paragraphs 4.4.1.b and c when properly installed and used in conjunction with the NCTF.

b. For the purpose of verifying that the dissemination subsystem has the capabilities listed in Paragraph 4.4.2.a, the highest vapor concentration called for by the individual test program, SPS, or CDD should be used as the target concentration. The dissemination subsystem capabilities (Paragraphs 4.4.2.a) should be verified by implementing the following steps:

(1) The vapor dissemination subsystem will be installed as per Paragraph 4.3.2.4. This includes placement of fans in the dissemination compartment to ensure a homogeneous concentration of simulant vapors throughout the dissemination compartment.

(2) All equipment, valves, and controls necessary to remotely operate the dissemination equipment will be installed.

(3) An appropriate chemical simulant will be selected to use in the verification. It is recommended that the selected simulant can be air washed and will not interfere with the subsequent use of other simulants.

(4) Challenge vapor referee instrumentation will be installed to sample from different locations in the dissemination compartment IAW Paragraphs 4.3.2.3. The referee instrumentation should be calibrated to the range of concentrations to be used in testing.

(5) The temperature, humidity, and pressure probes should have already been activated during the pressurization subsystem test (Paragraph 4.4.1). They should be checked to verify that the probes are measuring and digitally recording the data using laboratory recording software. The data must contain a date and time stamp.

(6) Before the dissemination system is activated, all unprotected personnel must vacate the test chamber.

(7) The referee instrumentation will be activated and checked to ensure that the instruments are measuring and transmitting background data to the appropriate storage device.

(8) All instruments will be synchronized for time and date.

(9) The dissemination system will be activated to achieve the desired low concentration of simulant, as specified in the program requirement document, SPS, or CDD. A low concentration of simulant will be maintained in the dissemination compartment for the time interval specified for the program.

(10) The dissemination system will be adjusted to achieve the desired mid-level concentration of simulant, as specified in the program requirement document, SPS, or CDD. The

mid-level concentration of simulant should be maintained in the dissemination compartment for the time interval specified for the program.

(11) The dissemination system will then be adjusted to achieve the desired high concentration of simulant, as specified in the program requirement document, SPS, or CDD. The high concentration of simulant should be maintained in the dissemination compartment for the time interval specified for the program.

c. The dissemination subsystem is considered to be functioning properly and acceptable for use when the target simulant vapors are generated and maintained throughout the dissemination compartment for the required period of time. The challenge vapor concentration and length of time must correspond to the requirements for a sustained release challenge, as described in each individual test plan. **NOTE:** The simulant challenge concentration throughout the dissemination compartment is considered homogeneous when all referee instruments record values within  $\pm 10$  percent of their challenge target concentration.

#### 4.4.3 Permeability of Barrier Liner Verification Process.

a. Barrier liner testing is usually performed in combination with the dissemination verification test. This verification process test is only necessary when using barrier liner materials for which swatch permeation data are not available.

b. Simulant vapors may permeate the material of a barrier liner, or they may permeate or penetrate the novel closure or seal between the barrier wall and the NCTF liner. Evaluation of any candidate novel closure must take all breakthrough routes into consideration.

c. Normally, candidate novel closures are embedded into material that has been previously tested and proven to be impermeable to the simulant vapors to be used in the trial. If the barrier material has not been previously tested, then the permeability of the barrier wall verification process may also be used to verify that the barrier wall is properly seated and sealed around the edges where it is clamped into the NCTF liner. **NOTE:** This verification process may also serve as a negative control test.

d. To implement the permeability of the barrier wall verification process, the NCTF, the barrier, and instrumentation will be installed and activated as follows:

(1) The NCTF will be set up and installed as described in Paragraph 4.3.1.2.

(2) A blank barrier wall made from the same material which contains the candidate novel closure will be installed as described in Paragraph 4.3.1.2.

(3) All TFA sampling instrumentation will be installed and activated as described in Paragraph 4.3.2.5. Stress points are usually the corners which have the highest probability of failure. Sampling lines connected to instrumentation should be placed about 1 foot from each corner of the barrier liner wall.

(4) The pressurized subsystem will be activated as described in Paragraph 4.3.2.1.

(5) All referee and sampling instrumentation will be activated as described in Paragraphs 4.3.2.2 and 4.3.2.3.

(6) All unprotected personnel must leave the test chamber before testing.

(7) The dissemination system will be activated for a sustained challenge, as described in Paragraph 4.3.2.4. The vapor concentration should be maintained for 2 hours in the middle to high range.

(8) The barrier wall is considered to be impermeable to simulant vapors and acceptable for use when no simulant vapors can be detected in the TFA 1 hour before the anticipated test period, during the test period, and 30 minutes after the test period.

(9) If any simulant vapors are detected in the TFA, operators will ensure the barrier wall is properly clamped and provides a vapor-tight seal. If repeat testing through this process continues to detect simulant vapors in the TFA, the material is not acceptable for barrier wall use.

e. This subsystem verification trial may be performed concurrently with the dissemination subsystem verification trial (Paragraph 4.4.2).

#### 4.4.4 Controlled Release Verification Process.

a. Before conducting the controlled release verification tests, the entire novel closures test system must be fully operational. As required, operators will perform installations, adjustments, and tests described in Paragraphs 4.3.1.2 through 4.4.3.

b. The following controlled release verification process will confirm that all subsystems are functioning properly and communicating:

(1) A barrier wall will be installed with a set of at least four holes or four “X-shaped” slits cut approximately 2.5 cm (1 in) long, or the cut will be made into the already installed blank barrier wall after the barrier wall verification process (Paragraph 4.4.3) is completed.

(a) The set of holes/slits will be made in the area of the barrier wall where the novel closure under test will be located.

(b) Each hole/slit should correspond to location where the TFA monitoring instrumentation probes will be located; therefore, there may be more than four cuts. The airflow must be slow enough for analytical instrumentation to have sufficient sampling opportunities.

(c) The outlet for the dissemination lines will be branched and located near each cut to ensure simulant escapes from the dissemination compartment through the cut and into the TFA.

(2) The pressurization system will be activated so that the TFA has  $0.6 \pm 0.10$  iwg pressure greater than the dissemination compartment.

(3) The referee and NRT sampling instruments will be started in the TFA and the dissemination compartments.

(4) The dissemination system will be activated, as described in Paragraph 4.3.2.4 and set to a concentration level of 150 mg/m<sup>3</sup>.

(5) Any detection of simulant vapors by the TFA monitoring instrumentation will be considered evidence that the overall test system is functioning properly.

c. It is unlikely that TFA sampling instrumentation will give a positive response when the TFA is at a higher pressure than the dissemination compartment. This result is to be expected because random Brownian motion of the disseminated vapor molecules does not permit simulant molecules to travel upstream against the pressure differential. When no simulant vapors are detected:

(1) The detection probes in the TFA may have to be placed up against the cuts or through cuts into the dissemination compartment.

(2) If the first option is not acceptable to the customer, the process described in Paragraph 4.4.4.b will be repeated with a reduced pressure differential between the dissemination compartment and the TFA.

d. Cross-contamination could occur if the simulant used during this verification process was the same simulant used in a previous or subsequent trial. Background levels must be kept to a minimum. To avoid cross-contamination in subsequent trials, it is recommended to use a simulant for controlled release verification testing that does not interfere with the analytical instruments being used to detect the simulant for use in closure trials.

#### 4.5 Chemical Vapor Challenge Test With Positive Pressure Differential.

a. This test is intended to simulate normal operational conditions for a ColPro shelter using the NCTF. ColPro shelters are erected so that pressure in the TFA is approximately 0.5 iwg above the surroundings.

b. The likely operational environment, operational mode, and encountered threats of a ColPro system under test will determine the type of novel closure testing to be conducted, as well as the type of chemical simulant used. These scenarios need to be mimicked to identify any potential limitations of and to fully confirm the protective capability of the candidate closures.

(1) A sustained challenge test is intended to replicate a situation in which an agent/simulant cloud passes by in a low-wind condition for a period of time exceeding 15 minutes. A low-wind challenge condition exists when a ColPro shelter is exposed to a vapor cloud challenge that is not sufficiently forceful to overcome the  $0.60 \pm 0.10$  iwg positive pressure of a normally operational ColPro shelter. The essence of the sustained chemical vapor challenge testing is to expose one side of a ColPro closure that has been embedded in a barrier liner to a specified concentration of simulant, and then to measure the mass of the simulant on the unexposed side of the test item over a specified challenge period.

(2) A pulsed challenge test is intended to replicate a situation in which an agent cloud passes quickly by the ColPro shelter so that the challenge exposure period is less than 15 minutes.

#### 4.5.1 Test Procedures.

##### 4.5.1.1 General Test Description.

a. This testing requires instrumentation to measure the concentrations of simulants at two levels: challenge concentration in the dissemination compartment in real time, and any possible trace levels inside the TFA.

(1) Historically, concentration measurements in the TFA were made with cumulative samplers, such as SSTs, which cannot provide real-time measurements for the very low concentrations likely to occur in the TFA. Some NRT instruments and point detectors can be remotely monitored, operated, and can record data digitally to obtain a better picture of the overall concentration profile as it changes over time.

(2) Air sampling in a sustained challenge test is conducted in two distinct sampling periods: the background period and the challenge period. During the background period, concentrations of residual simulant are measured in the TFA. Background concentration can be problematic when a simulant with low vapor pressure is used repeatedly in subsequent trials and is retained through sorption on the fixture or liner surfaces.

b. To mimic the typical operational scenario of a ColPro shelter, the positive-pressure test requires the TFA compartment to be  $0.60 \pm 0.10$  iwg higher than the dissemination compartment.

##### 4.5.1.2 Test Preparation and Pretrial Procedures.

a. Before conducting a positive pressure test, the NCTF and the liner, as well as the test instrumentation, will be installed and set up IAW the procedures described in Paragraphs 4.3.1.2 and 4.3.2, respectively. A photographic record of the instrument placement is recommended.

(1) The referee instruments will be installed outside the NCTF and connected to the data collection system as described Paragraphs 4.3.2.5 and 4.3.2.6.

(2) Sampling lines from referee instrumentation will be connected to pass-through ports and extended to various places within the compartment to determine homogeneity of the challenge vapor concentration.

(a) For example, if only two detectors are used, one sampling line should be located approximately one-third of the distance from the airlock and about one-third the distance from floor to ceiling. The second sampling line should be located two-thirds of the distance from the airlock and two-thirds the distance from floor to ceiling. When four detectors are used, the sampling lines should be staggered up and down, front to back, and side to side in the dissemination compartment.

(b) Simulant challenge concentration throughout the dissemination compartment is considered to be homogeneous when all analytical instruments have values within 10 percent of their target challenge.

(3) The TFA monitoring instruments will be installed and connected to the data collection system, as described in Paragraph 4.3.2.6.

b. All analytical instruments will be set to record data at least every 5 minutes for sustained trials and 1 minute for pulse trials. This should be a sufficiently short time interval without necessitating the undue burden of collecting extremely large amounts of data. Some NRT instruments record data at longer intervals, but use of the shortest duration sampling period is recommended.

c. The temperature and RH probes will be set to digitally record data at a minimum of 60-second intervals.

d. Referee instrumentation, sampling instrumentation, temperature, humidity, and pressure probes are to be synchronized for date and time.

e. All clocks and time stamps for all data collection devices will be synchronized. This includes, but is not limited to:

- (1) All analytical instruments in the dissemination compartment.
- (2) All analytical instruments in the TFA.
- (3) Remotely operated dissemination equipment.
- (4) Mechanically operated sequencers for SSTs.
- (5) Pressure, temperature, and humidity sensors.
- (6) Recording devices.

f. Some analytical instruments, particularly for low-concentration measurements (e.g., pre-concentration techniques), inherently have a time delay between obtaining a sample and reporting the concentration of that sample. This offset between the time of sample acquisition and the time of the generation of the concentration report must be accounted for in the data analysis.

g. Before any trials for record, the verification trials, described in Paragraph 4.4, will be conducted once at the beginning of the test program to ensure all subsystems are properly functioning.

h. All test instrumentation will be calibrated IAW the procedures in Paragraph 4.3.2.7.

#### 4.5.1.3 Chemical Vapor Challenge Test Procedures.

a. Simulant selection, vapor concentration to be achieved, and the duration of the challenge concentration for each trial will be as specified by the SPS or DTP. **NOTE:** Enough simulant must be disseminated, as specified by the DTP, to provide the amount necessary to maintain vapor concentration for the duration of the trial.

b. All test and referee instrumentation, computer control, and data recording systems will be initiated.

(1) The NRT instrumentation, such as MINICAMS<sup>®</sup>, vacuum pumps, and high-pressure gas cylinders will be located outside the test fixture. This will permit ready access to the MINICAMS<sup>®</sup> to verify calibration at the start of each trial.

(2) Heated sample lines for the NRT instrumentation will be connected to the pass-through ports into the fixture.

(3) Data collection software will be activated for the NRT instrumentation. The operator will verify that the software is digitally recording data.

(4) If cumulative dose samplers, such as SSTs, are used, they will be installed in the TFA with the necessary electronic sequencer. An electrical power cord from the sequencer will extend to a power source outside the fixture. The sequencer will alternate the vacuum source among each cumulative dose sampler in the group so that one cumulative dose sampler is sampling for each time period throughout the trial. Each set of cumulative dose samplers will be co-located to obtain samples from the same location throughout each trial. **NOTE:** Any premature simulant vapors samples from cumulative dose sampler will bias actual test data. Therefore, the cumulative dose sampler, electronic sequencers, and vacuum pumps should only be turned on when the challenge concentration is at the target value and a trial of record begins.

(a) TFA air-sample flow rates will be measured by inserting, in series with each cumulative dose sampler, a calibrated flow measurement device. Airflow rate measurements will be taken while the compartments are pressurized and blower motors are operating for a trial of record to ensure the cumulative dose samplers' sampling is unaffected.

(b) Measurements should be performed with the same vacuum source used in actual air sampling. For each tube, three readings should be taken before the test and three readings taken after the test before removing the cumulative dose samplers. The relative standard deviation of the airflow measurements should be less than 5 percent.

c. Environmental monitors will be activated IAW the procedures in Paragraph 4.3.2.1.

d. Blower motors will be started to create pressure differential.

(a) During the trial, differential pressure inside the TFA and the dissemination compartment will be maintained at  $0.60 \pm 0.10$  iwg positive pressure (not to exceed  $0.85 \pm 0.10$  iwg). The pressure from all locations will be measured, monitored, and digitally recorded.

(b) It is recommended that the blower motor for the TFA be adjusted on a 5-minute time scale and the blower motor for the dissemination compartment be adjusted on a 1-minute time scale. This will ensure that the two blower motor systems do not fight or counteract each other.

e. The simulant vapor will be disseminated IAW the procedures described in Paragraph 4.3.2.4.

(1) For a sustained vapor challenge, the vapor concentration will be maintained for the time prescribed by the individual test requirements, as specified by the SPS or DTP.

(2) The challenge vapor concentration will be steadily increased from zero to the target concentration. **NOTE:** During simulant dissemination, all unprotected personnel will remain outside of the test chamber. No unprotected personnel will be in or near the NCTF during the vapor challenge.

f. The progress of the test will be periodically monitored to ensure safe operations at the desired test conditions.

g. All instrumentation will be operated remotely.

h. Data output will be monitored in real time throughout the test to ensure reasonable data collection, sustainment of required test conditions, and confirmation that instruments are operating properly.

(1) Detection time, elapsed trial time of detection, and concentration of any simulant vapor in the chamber will be recorded by laboratory recording software, such as LabVIEW<sup>®</sup> software.

(2) The temperature, RH, and air pressure data inside each compartment will be digitally recorded. Differential pressures will be calculated from the air pressure measurements.

i. Still photographs will be taken to document the relative location of the installed novel closure and the locations of the analytical instrumentation inside the TFA with respect to the novel closure. To the extent practical, photographic scale rulers should be included within the photograph to show appropriate dimensions and distances.

#### 4.5.1.4 Trial Termination.

a. The trial will continue until any breakthrough mass exceeds the permissible breakthrough mass, as specified by the SPS or DTP, or until the predetermined trial duration limit is reached.

b. The dissemination equipment will be turned off. The simulant air stream will be diverted from the test fixture to the filter bank.

c. The blowers will continue to operate to allow simulant-free process air to pass through the NCTF and clear out any residual vapors.

d. All referee and sampling instruments will remain active to record corresponding data.

(1) The background levels of the simulant vapor in both NCTF compartments will continue to be measured. **NOTE:** Background levels will not exceed the exposure values of the CWA, which the simulant is representing. The test requirement documents should specify which exposure values [permissible exposure level (PEL), threshold limit value (TLV), military exposure guidelines (MEG), etc.] that will be used for the test.

(2) If background levels are exceeded, purging and air washing the fixture will continue until background readings fall below the exposure value specified by the test requirement document.

e. The trial will be terminated when the simulant concentration decreases to background levels.

(1) The electronic sequencers and vacuum pumps for the cumulative dose sampler will be turned off when the trial of record ends. This will avoid sampling any simulant vapors before testers have the opportunity to complete an ending flow rate check and remove the cumulative dose samplers for laboratory analysis. **NOTE:** When the simulant vapors have cleared and test personnel are permitted to enter the chamber, the electronic sequencers and vacuum pumps can be turned on for the ending flow rates.

(2) The cumulative dose samplers will be collected as soon as the simulant vapor concentration inside the TFA falls to background levels.

(3) In the event simulant vapor concentrations cannot be reduced to background levels, one of the following actions may be taken before the next trial:

(a) The next trial may be conducted with a different simulant whose analytical instrument response does not interfere with the previously used simulant. This will allow a longer time for the previously used simulant to clear.

(b) The barrier wall and novel closure may be changed with an unused or “clean” barrier wall.

(c) The liner may be replaced with an unused liner.

f. Unprotected personnel will remain outside the chamber until vapor levels inside the chamber and inside the two compartments of the NCTF are below exposure values specified by the test requirement document. Those entering the chamber and NCTF after a trial will wear appropriate National Institute of Occupational Safety and Health (NIOSH)-approved respirators with appropriate filters and other appropriate PPE, as required and specified by the test facility’s SOPs. The respirators are required even if personnel enter the test chamber but do not enter the NCTF dissemination compartment.

#### 4.5.1.5 Final Retrograde.

- a. Upon completion of all testing, barrier liners and C-shaped liners will be disposed IAW the installation hazardous waste management plan.
- b. The NCTF will be disassembled and stored for future testing.
- c. The blower motor system will also be stored with the test fixture.
- d. All instruments will be stored with their respective support groups.

#### 4.6 Chemical Vapor Challenge Test With Negative Pressure Differential.

a. ColPro shelters may experience high-wind conditions in which the outside wind pressure may force a chemical agent cloud up against the ColPro shelter. Under these temporary high-wind conditions, the pressure inside the TFA may fluctuate up to 0.5 iwg below the surroundings. The negative pressure differential test is intended to simulate this type of pressure regime inside the ColPro shelter.

b. The negative pressure differential trials will be conducted IAW the procedures in Paragraph 4.6, with the following exceptions: the pressure inside the dissemination compartment will be -0.15 iwg, and the pressure inside the TFA will be -0.65 iwg relative to the test chamber. This combination will result in a pressure differential across the novel closure of 0.50 iwg.

#### 4.7 Chemical Vapor Challenge Test With Equal Pressure Differential.

a. This test is designed to simulate conditions, such as a blower failure or power loss, where there is no significant overpressure possible between the TFA and dissemination compartments.

b. A chemical vapor challenge test with equal pressure differential will be conducted IAW the procedures in Paragraph 4.7, with the following exceptions: the pressure inside both compartments will be equal and will be -0.15 iwg relative to the pressure outside the test fixture.

### 5. DATA REQUIRED.

**NOTE:** All instrument data must be time stamped.

#### 5.1 Receipt Inspection Data.

- a. A photographic and text record of all inspected test material and inspection results.
- b. Any material deterioration or damage.
- c. Record of repaired or replaced test material.
- d. The operational status of closures.

e. CWA simulant name, Chemical Abstracts Service (CAS) number, supply source, and purity information.

## 5.2 Pretest Data.

### a. Fixture and Liner Installation and Setup Data.

(1) Photographs of the assembly of the fixture by stages.

(2) Photographs of the arrangement and location of all ancillary components, such as blower motors, exhaust fans, pass-through ports, etc.

(3) Location of all equipment, instruments, and sampling locations in the dissemination chamber and TFA.

### b. Instrument Setup and Calibration Data.

(1) Differential pressure data from each compartment.

(2) Real-time environmental condition.

(3) Temperature inside the chamber and in each of the two fixture compartments.

(4) RH inside the test chamber and within each NCTF compartment.

### c. Instrumentation Data.

(1) Photographs and text records of location of all referee and sampling instrumentation, and sampling locations in the dissemination chamber and TFA.

(2) Simulant type, list of simulant dissemination instrument, amount of simulant disseminated.

(3) Still photographs will be taken to document the relative location of the installed closure and the locations of the sampling instrumentation in the TFA with respect to the closure, including photograph scales or rulers.

(4) All records of instrument maintenance and calibration.

### d. NCTF and Subsystem Verification.

(1) Pressure differential achieved and maintained in the dissemination compartment relative to the chamber.

(2) Pressure differential achieved and maintained in the TFA compartment relative to the chamber.

(3) The time to achieve each change in pressure in the TFA compartment.

- (4) The length of time that the pressure differential was sustained.
- (5) Background simulant concentration recorded before the simulant test.
- (6) Record of the highest and lowest challenge concentration that the dissemination system was able to achieve.
- (7) The length of time that the challenge concentration was maintained.
- (8) Simulant vapor detection data for 1 hour before the permeability of barrier wall verification test, during the test period, and ½ hour after the test period.
- (9) Record of any repairs or adjustments made to the barrier because of failure in the barrier wall verification test.

### 5.3 Vapor Challenge Test Data.

a. Data to be collected include: challenge concentrations, breakthrough concentrations, and the time of breakthrough, which will be reported. Ancillary or secondary data include pressure from all locations, pressure differentials on both sides of the candidate closure relative to each other, and the temperature and humidity conditions during testing.

b. Detection time, elapsed trial time of detection, and concentration of any simulant vapor in a chamber will be recorded.

c. Data streams listed below will be digitally recorded for each challenge trial. All data streams will have an associated time stamp that calculates the start time, stop time, sampling frequency, and elapsed time for all data streams.

(1) NRT concentrations of simulant vapor in the dissemination compartment during the challenge period.

(2) NRT measurements of any mass of simulant vapor in the TFA.

(3) Sampling airflow rates of cumulative samplers (e.g., SSTs) in the TFA (when used).

(4) Initial and final amount of simulant, and airflow rate of simulant vapor.

(5) Temperature and RH measurements in the NCTF compartments and outside the fixture but within the test chamber.

(6) Differential atmospheric pressure measurements between the TFA and the test chamber and between the dissemination compartment and the test chamber.

d. Any anomalies observed during any of the tests and any observations about the anomalies will also be recorded.

#### 5.4 Data Analysis.

a. Simulant vapor concentrations measured in the dissemination compartment may be compared with each other to determine the average challenge concentration and to ascertain the homogeneity of challenge vapor concentration throughout the dissemination compartment.

b. Data from sampling instrumentation in the TFA will be compared with the challenge concentration to determine locations of permeation and possible weak points. The data will be plotted as mass versus time.

c. The mass of simulant detected in the TFA will be recorded as a function of time at various locations around the candidate novel closure. The mass can be converted to concentration by knowing the airflow through the analytical detection device. However, this will only be a localized concentration and will not be indicative of the simulant concentration that may exist throughout the TFA.

d. The simulant dosage [concentration multiplied by time (Ct)] that may be calculated from using the test procedures described in this document can not be extended to any one ColPro shelter. The air volume in the TFA and the air exchange rate most likely will be significantly different from the NCTF used and the ColPro shelter that may be fielded.

#### 5.5 Primary Measure of Performance.

Candidate novel closures must pass user-defined requirements. The pass/fail requirements may depend on miosis hazard level, inhalation hazard level, or other user-defined action level for a given simulant or CWA. Any breakthrough (defined as X mg of challenge vapor detected in the TFA) or any detection of permeation will be noted in the test report.

#### 5.6 Replicate Testing and Computation.

a. All data streams will be arranged IAW their respective time stamp and compartment where the data stream was collected.

b. Most instruments have a short delay from the time the sample is collected to the time the instrument records the value. To account for delay time in all data streams, the time delay (if any) for each analytical instrument will be added in when measuring and recording the concentration.

c. Only one set of temperature, humidity, and pressure probes will be used in each corresponding compartment at any given time. Because these conditions are maintained in the chamber during test conduct, it is assumed that the environmental conditions are uniform throughout the corresponding compartment.

d. To compare data in different locations inside the same compartment, data streams for each type of instrument will be arranged by instrument and the sampling location of that instrument.

(1) Data streams for each type of instrument inside the dissemination compartment may be compared as a measure of homogeneity of the challenge cloud concentration.

(2) Data streams for each type of instrument in the TFA will be compared to determine where breakthrough of the novel closure occurs. Since homogeneity is never designed to be achieved in the TFA, the data streams from different sampling locations will not be compared for homogeneity. Data streams from different samplers at the same location may be compared for accuracy of simulant concentration only at that particular sampling location.

e. Data streams from each compartment will be arranged by sampling location inside the compartment. Different data streams from each location can be compared as a measure of data precision and verification at that particular location. Data streams of different instruments will generally have different sampling frequencies. Only those data points with the same time stamp can be compared across different types of challenge vapor instruments.

(1) Challenge vapor concentration in the dissemination compartment should be fairly constant throughout the trial. Therefore, the maximum, minimum, and average values may be computed for each instrument. When two different analytical instruments are sampling at the same location, the values may be compared to determine the precision of the vapor concentration at that particular location.

(2) Any vapor concentration measured in the TFA will not remain constant, but should steadily increase from the time of breakthrough until such time that the breakthrough concentration (when possible) is equal to the challenge vapor concentration. Therefore, the maximum, minimum, and average concentration values need not be determined for any TFA monitoring instrument. Instead, the data should be examined by time stamp across the instruments at each sampling location. Only those data points with the same time stamp can be compared to determine the precision of the vapor concentration at that particular location.

(3) Cumulative samplers such as SSTs have longer sampling intervals than do point detectors or NRT instruments. When comparing the measured concentration between TFA monitoring instruments and the SSTs, individual data points for each instrument must be summed IAW the sampling interval of the SSTs. The summed values can be compared to the overall concentration measured by the SSTs.

#### 5.7 Data Quality Objectives.

a. Data quality objectives (DQOs) are designed to ensure scientifically valid and legally defensible data is obtained during testing. Both random and systematic errors in the measurements can occur because of shortcomings in test procedures, data collection equipment, and in data analysis systems. DQO principles are applied to measurements to determine how much error is acceptable before the data should be rejected.

b. Independent parameters most likely to vary during a single test trial include: airflow through dissemination equipment, chemical vapor flow rate through dissemination equipment, dissemination concentrations, challenge air inlet temperature, and RH. Lack of consistency in these parameters will affect performance measurements. The DQOs in Paragraph 5.7.c are in

reference to a single trial only. If any DQOs are not met, subsequent trials should not continue until the test apparatus and setup of the NCTF is evaluated, and any problems are addressed or corrected.

c. The following specific steps will be adopted to ensure quality data are obtained:

(1) Uniformity of the challenge vapor concentration in the dissemination compartment will be verified before conducting trials of record.

(2) Circulating fans will be operational.

(3) Uniform concentration with NRT instruments will be verified by measuring the vapor concentration in at least three different locations inside the dissemination compartment for a period of 30 minutes.

(4) All measured concentrations will not have a spatial deviation greater than 10 percent from the average value.

## 6. PRESENTATION OF DATA.

a. The test report will include the following data:

(1) A description of the novel closure tested.

(2) The simulant used and the CAS number of the simulant.

(3) The target pressure differential used in the fixture.

(4) The type of trial conducted, whether sustained or pulse

b. The test report will include the following data, arranged by trial:

(1) Challenge vapor concentration over time.

(2) The breakthrough mass at each sampling location over time.

(3) The time when first breakthrough occurred for each sampling location.

(4) Pressure differential between compartments over time.

(5) Temperature in each compartment and the chamber over time.

(6) The RH in each compartment and the chamber over time.

(7) Number, type, and location of analytical instrumentation used in the dissemination compartment.

(8) Location of analytical instrumentation in the TFA, with respect to the location of the novel closure.

(9) Photographic record of the test event.

c. Any additional desired reports, recommendations, etc., will be determined by the customer and specified in the test requirements.

7. FIXTURE VERIFICATION AND VALIDATION.

All new novel closure fixtures must be verified and validated. All verification and validation testing must show that the fixture will perform to the specifications outlined in this top. **NOTE:** The validation trial results for the West Desert Test Center (WDTC), DPG, novel closure fixture is found in the novel closures test fixture report<sup>7</sup>. Any verification test plan and results will need to be reviewed and accepted by the capability area process action team [CAPAT, Office of the Deputy Under Secretary of the Army, Test and Evaluation (DUSA TE)]. Accreditation of the fixture will be at the discretion of the operational tester.

TOP 08-2-201  
28 March 2013

(This page is intentionally blank.)

APPENDIX A. NOVEL CLOSURES TEST FIXTURE DESCRIPTION.

A1. NOVEL CLOSURES TEST APPARATUS.

A1.1. Overview.

a. The test fixture is constructed as a rigid-framed, aluminum, rectangular-shaped structure with an acrylic plastic wall attached on the airlock end and another acrylic plastic wall on the opposite end to enhance fixture rigidity (see Figure A-1).

b. The floor and ceiling of the structure are open but still have a support bar down the longitudinal center of the structure, across the top and bottom, to aid in stability and to support the liner and the barrier liner. Moveable instrumentation posts, shown in red on the sides of the framework in Figure A-1, are provided to allow attachment of instruments and support cables/hoses, etc., as needed.

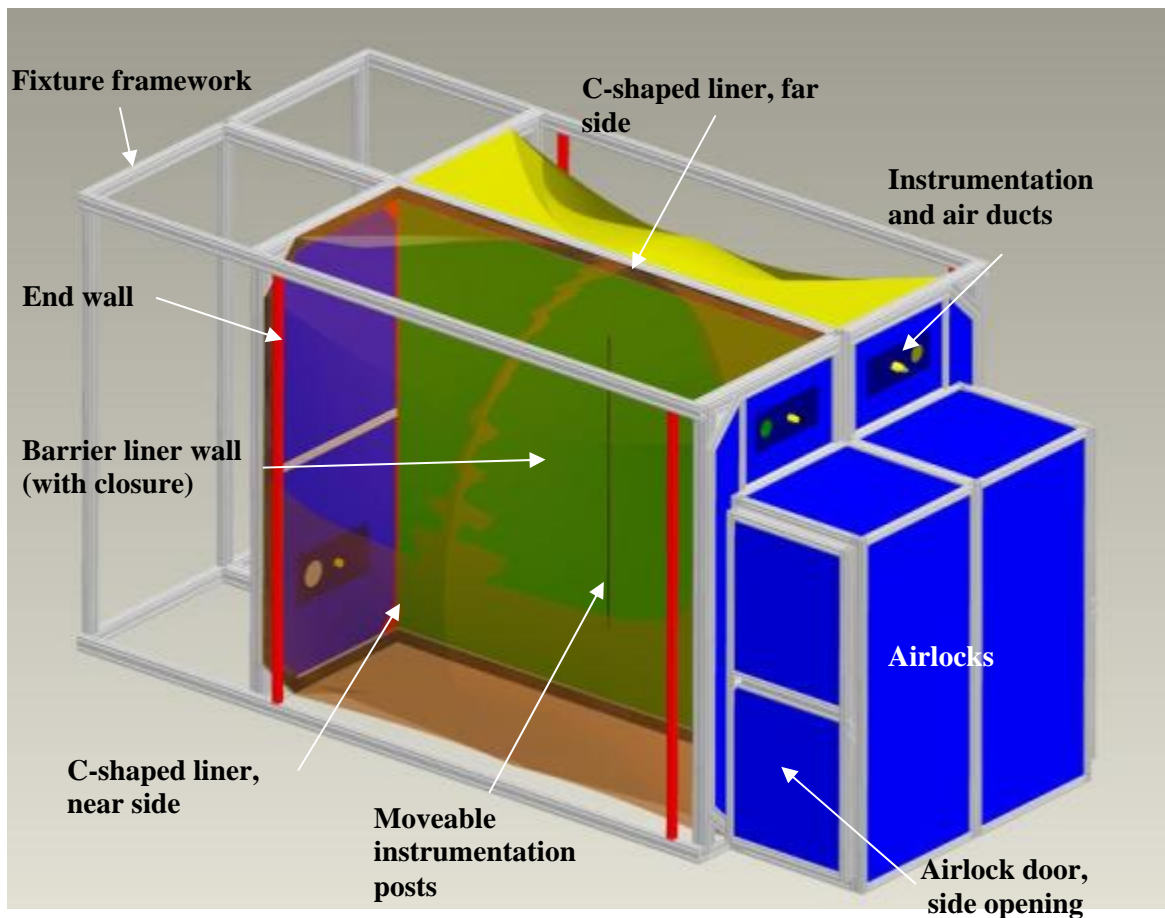

Figure A-1. NCTF side view drawing of open framing with liner and barrier liner installed.

## APPENDIX A. NOVEL CLOSURES TEST FIXTURES DESCRIPTION.

c. The length of the fixture can be adjusted by sliding the end wall toward the airlocks. For safety reasons, a set of empty rails was attached to the longitudinal framing to cap the ends. Figure A-1 shows this adjustable capability. The end wall can be moved toward the airlocks, thereby accommodating installed C-shaped liners and barrier liners of various lengths, as required by the novel closure under test.

d. The fixture dimensions and features are designed to accommodate instrumentation for measurement of the challenge vapor concentration, the breakthrough vapor concentration, and the environmental conditions.

(1) The overall dimensions of the fixture, excluding the airlocks, are ~2.5 m (~8 ft) wide by ~3.0 m (~9 ft) high, with a variable length from ~2.1 to ~4.3 m (~7 to ~14 ft). During characterization, it was discovered that an absolute minimum length of 1.8 m (6 ft) is required for access to the dissemination and TFA compartments and for the placement of instrumentation.

(2) The fixture will securely hold a barrier liner that is ~3.0 m (~9 ft) tall and of variable length from ~2.1 to ~4.3 m (7 to 14 ft).

e. Two similarly structured, fixed-sized, rigid-framed airlocks are attached at one end to provide personnel access to the TFA and the dissemination compartments for setting up and installing the support instrumentation. The airlocks each have two doors to permit test personnel to enter and exit the fixture without compromising the internal pressure. The walls of the airlocks and doors consist of acrylic plastic (depicted in blue in Figure A-1). The door jambs have a rubber gasket to provide a seal when the doors are closed. The airlocks do not have any positive pressure or negative pressure requirements. The pressure inside the airlocks can be the same as the pressure inside the test facility chamber.

f. The entire system, consisting of the novel closures test fixture and ancillary equipment and instruments, is shown in Figure A-2. The instrument and equipment placement for some items (for example, mixing fans) is optional, depending on the needs of the test.

### 1.2. Liner Description.

a. Two C-shaped liners are fastened to the interior of the fixture in a manner similar to that shown in Figure A-1. A cross-sectional schematic drawing of the liner-to-fixture seal is shown in Figure A-3. The two liners are used and installed on each side of the test fixture in a lengthwise manner. The liners create a fully enclosed space in which the novel closure under test can be installed. In Figure A-1, the closest C-shaped liner is shown as transparent amber, and the second C-shaped liner is shown on the far side of the fixture as yellow.

b. The liners are constructed of material/fabric typically found in a fielded ColPro shelter; for example, M28 material.

c. The liner must be of tight and impermeable construction, and sealed on all sides when installed into the test fixture, to provide a vapor-tight barrier. Any vapor leakage around the edges could be misconstrued as breakthrough of the candidate novel closure.

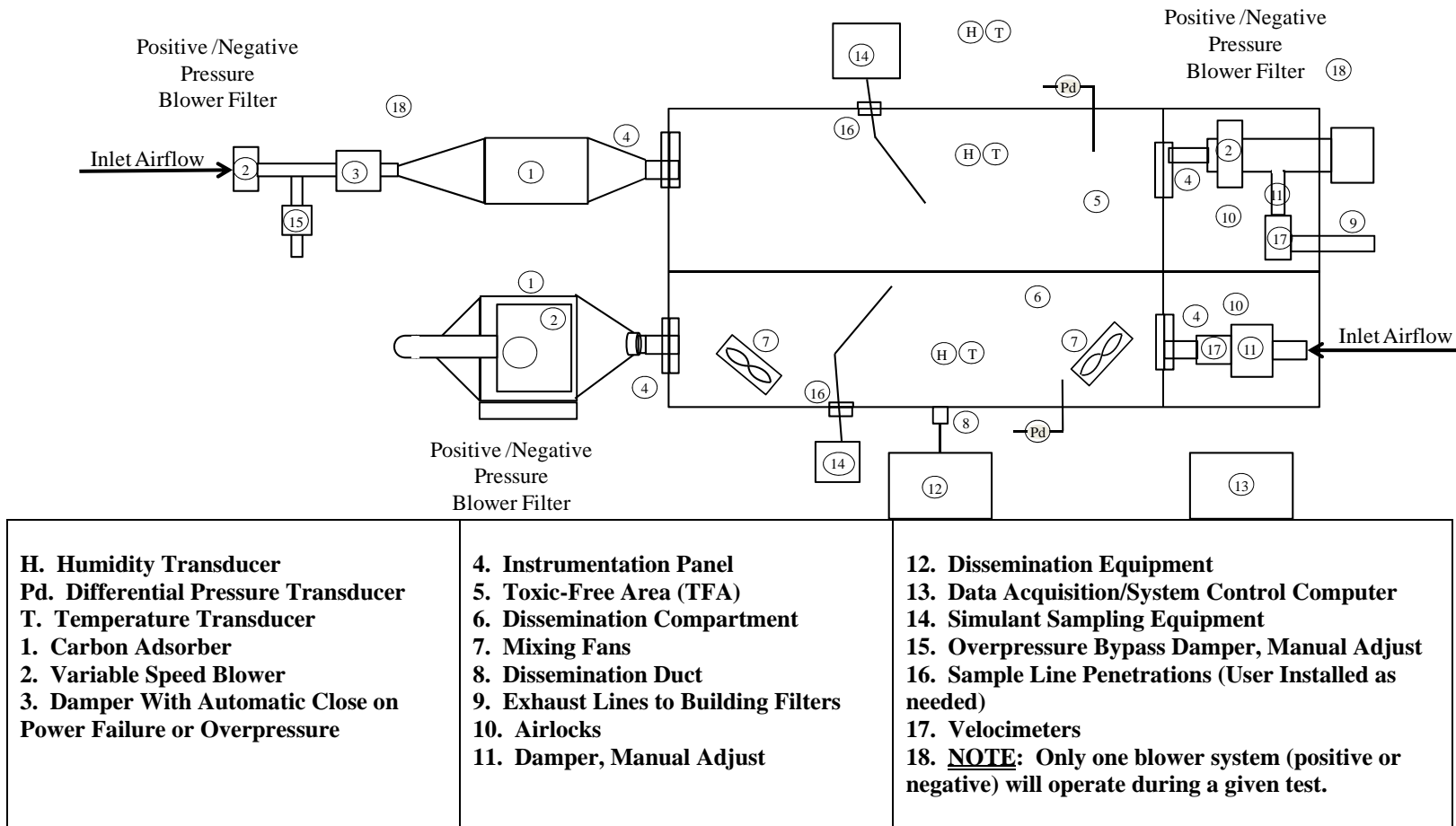

Figure A-2. Detailed floor plan for the NCTF and suggested instrument/equipment placement.

APPENDIX A. NOVEL CLOSURES TEST FIXTURES DESCRIPTION.

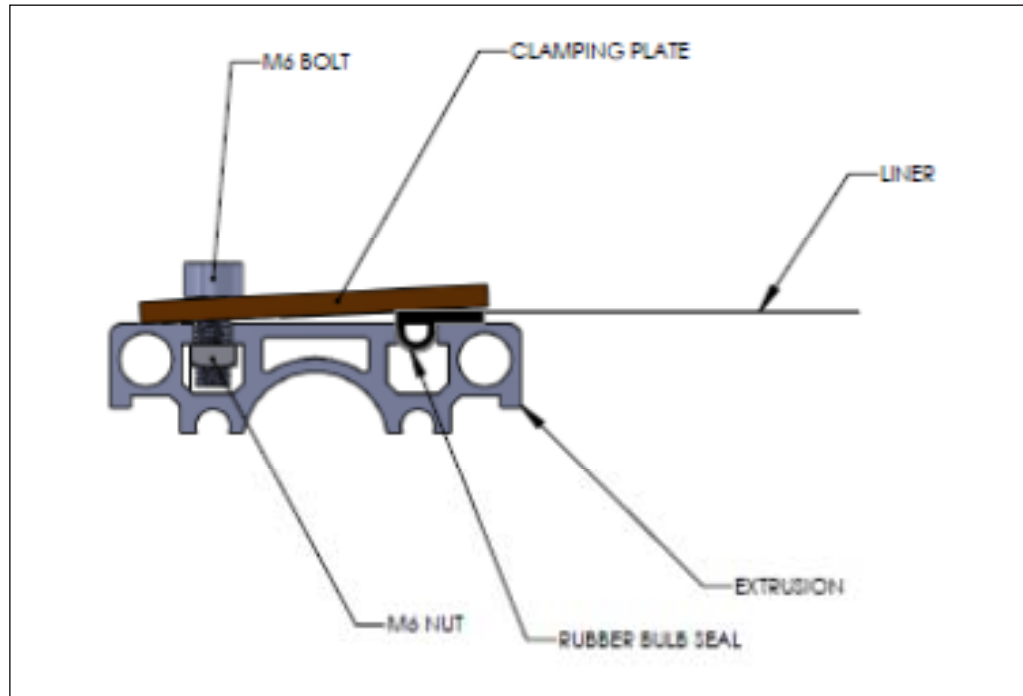

Figure A-3. Schematic drawing of liner-to-fixture seal used in the NCTF.

d. The installed liners must be capable of maintaining a differential atmospheric pressure from ambient air pressure through  $1.00 \pm 0.10$  iwg relative to the outside (chamber) pressure in case of overpressure. The pressurization subsystem must be able to maintain pressure in the dissemination compartment of  $-0.15 \pm 0.10$  iwg relative to the chamber pressure. The pressurization subsystem must be able to maintain pressure in the TFA between  $-0.25$  and  $+0.75 \pm 0.10$  iwg relative to the chamber pressure. The pressurization subsystem must be able to maintain a pressure differential between  $0.10$  and  $0.60 \pm 0.10$  iwg between the dissemination compartment and the TFA compartment.

A1.3. Barrier Liner Description.

a. The candidate novel closure is embedded into a solid yet flexible barrier liner of single construction for testing. The only opening allowed in the barrier liner is at the novel closure that will be evaluated. The barrier liner is constructed of material/fabric typically found in the liner of a fielded ColPro shelter.

## APPENDIX A. NOVEL CLOSURES TEST FIXTURES DESCRIPTION.

b. The customer/developer is responsible for ensuring the candidate novel closure is properly embedded into the barrier liner. This may be done in consultation with Natick Soldier Center (NSC, Natick, Massachusetts) or another manufacturer of the developer's choosing. The customer/developer is also responsible for coordination with the testing facility to ensure the barrier liner with the embedded novel closure will fit into the test fixture. The testing facility is responsible to ensure the barrier liner is properly sealed into the test fixture.

c. The barrier liner and liner do not have to be made of the same material.

d. The barrier liner is mounted inside the test fixture in a lengthwise fashion and is sealed to the test fixture around the perimeter. This divides the interior of the fixture into two main compartments of equal dimension. An installed barrier liner with a vertical closure is depicted in green in Figure A-1. The installation of the barrier liner will be complete enough to prevent vapor penetration through the seal.

e. One of the two main interior compartments will be the clean compartment, representing the protected area or TFA of a ColPro shelter. The other compartment will be the dissemination compartment where vapor dissemination will take place, representing the area outside the shelter TFA during a chemical release or CWA attack.

f. For test purposes, it is optimal to have ~0.6 m (~2 ft.) clearance between the novel closure and the liner ceiling and walls, but this may be modified for specific test needs. This clearance around the candidate closure is necessary to avoid wall effects and still provide enough room for the TFA monitoring instrumentation. A smaller clearance may be acceptable near the liner floor for novel closures that are designed for personnel entry/exit.

### A1.4. Pass-Through Ports Description.

a. The fixture is constructed with pass-through panels in the C-shaped liners for lines and cables, etc., that will provide service access for airflow, electrical, detector, and other instrumentation or hardware.

b. Other than the opening at the novel closure under test, no pass-through ports or openings are in the barrier liner.

c. A port or opening into the dissemination compartment is required to permit dissemination of a vapor stream from outside the test fixture into the dissemination compartment. This port should be located in the center of the dissemination compartment for ease in generating a vapor challenge of uniform concentration throughout the dissemination compartment. Operation of the dissemination equipment will be performed remotely by personnel outside of the chamber.

d. Removable panels are provided in the acrylic walls at both ends of the fixture for each compartment. These panels contain the blower and exhaust ducts and equipment ports as required. The environmental conditions inside the airlocks will not be measured or recorded.

#### APPENDIX A. NOVEL CLOSURES TEST FIXTURES DESCRIPTION.

e. There are at least two ports or openings into the TFA for placement of sampling lines for any analytical instrumentation placed in the TFA. Additionally there are at least two ports installed to accommodate analytical equipment/instrumentation lines placed in the dissemination compartment. The instrumentation ports are located to correspond to the location of the closure in the barrier liner. This placement will ensure the shortest sampling lines are used. These are user-installed in the liner wall during fixture setup, and the location and quantity of ports may vary from closure to closure and from test program to test program. Figure A.4 shows an illustration of one of these ports.

f. All pass-through ports in the liner are sealable ports to maintain containment of simulant vapors inside the test fixture and to maintain the necessary pressure differentials.

g. One port is located in the replaceable panel in each compartment at the end opposite the airlocks for an inlet blower-motor airstream and for pressurizing each compartment.

#### A1.5. Blower Motor and Exhaust System.

a. A filter is used in series with the TFA blower to prevent any simulant vapors from entering the TFA compartment via the inlet air system.

b. The effluent is exhausted directly into the chamber air-filtration system. This will reduce the possibility of contaminated effluent air from recycling into the TFA's inlet system and biasing the test results. Dampers on the exhaust ports will control exhausting. The exhaust ports are located in the replaceable panels located in the wall above the airlocks.

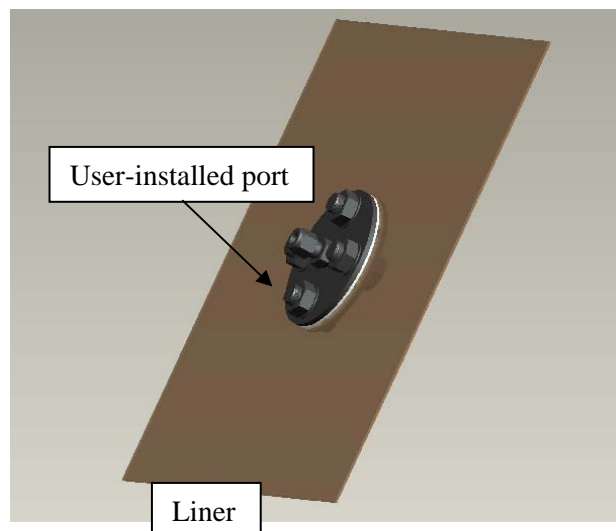

Figure A-4. Illustration of liner into the NCTF with user-installed port.

APPENDIX A. NOVEL CLOSURES TEST FIXTURES DESCRIPTION.

c. The differential pressures (between the dissemination compartment and the area outside the fixture, and the pressure between the dissemination compartment and the TFA) are adjusted by using the dampers for the coarse adjustment and electronically controlling the speed of the blowers for the fine adjustment.

d. The blower motors are of sufficient capacity that the liner can be properly inflated and the required positive pressures sustained without running at full-motor capacity limits. The pressure levels are controlled by varying the output of the blowers.

e. An automatic damper system is used in conjunction with the blower. In case of power failure, the damper will close, reducing the amount of disseminated vapor that may backwash into the inlet blower system.

f. The inlet blower air lines for the dissemination compartment and the inlet blower air lines for the TFA compartment will each include a pressure-activated switch to disable the blower should the pressure in the associated compartment exceed a preset level (e.g., 1.00 iwg). The switches will enable the blowers when the pressure drops to an acceptable level (e.g., 0.85 iwg). The pressure-activated switches are intended to keep the pressure in each compartment within a range of acceptable values.

g. The blower motors for each compartment operate independently of one another.

h. Airflow meters may be installed on the exhaust lines. The airflow meters are intended to measure the air turnover rate inside each compartment during testing.

(This page is intentionally blank.)

APPENDIX B. ABBREVIATIONS.

AD No.	accession number
ANSI	American National Standards Institute
ASR	agent-simulant relationship
ATEC	U.S Army Test and Evaluation Command
ATTN	attention
BP	Building Protection
CAPAT	Capability Area Process Action Team
CAS	Chemical Abstracts Service
CB	chemical and/or biological
CBR	chemical, biological, and radiological
CDD	capability development document
ColPro	collective protection
CPD	capabilities production document
CSV	comma-separated value
Ct	concentration multiplied by time
CWA	chemical warfare agent
DA	Department of the Army
DAQ	data acquisition
DoE	design of experiment
DPG	U.S Army Dugway Proving Ground
DQO	data quality objective
DT	developmental test
DTIC	Defense Technical Information Center
DTP	detailed test plan
DUSA TE	Deputy Under Secretary of the Army, Test and Evaluation
EA	environmental assessment
EDP	event design plan
EIALC	environmental impact assessment for life cycle

APPENDIX B. ABBREVIATIONS.

EIS	environmental impact statement
FTIR	Fourier-transform infrared
GC	gas chromatograph
HHA	health hazard assessment
HUC	Human Use Committee
IAW	in accordance with
IHP	industrial hygiene plan
IMS	ion mobility spectrometry
ISO	International Organization for Standardization
iwg	inches water gauge
kPa	kilo Pascal
MCC	Multicapillary-Column
MEG	military exposure guideline
MINICAMS <sup>®</sup>	a miniature, automated, continuous air-monitoring system
SDS	safety data sheet
NCSL	National Conference of Standards Laboratories
NCTF	Novel Closures Test Fixture
NEPA	National Environmental Policy Act
NIOSH	National Institute of Occupational Safety and Health
NIST	National Institute of Standards and Technology
NRT	near real-time
NRTM	near real-time monitor
NSC	Natick Soldier Center
OMB	Office of Management and Budget
OM	operator manual
OT	operational test
PAM	pamphlet

APPENDIX B. ABBREVIATIONS.

PEL	permissible exposure level
PID	photoionization detector
ppb	parts per billion
ppbRAE®	handheld PID manufactured by RAE Systems capable of measuring VOC at the ppb level
PPE	personal protective equipment
psi	pounds per square inch
QA	quality assurance
QC	quality control
REC	record of environmental consideration
RH	relative humidity
RTM	real-time monitor
SAR	safety assessment report
SEP	system evaluation plan
SOP	standing operating procedure
SPS	system performance specification
SR	safety release
SSP	system support package
SSPL	SSP list
SST	solid sorbent tube
T&E	test and evaluation
TB	technical bulletin
TEMP	test and evaluation master plan
TFA	toxic-free area
TI	technical instruction
TIC	toxic industrial chemical
TICN	test item control numbers

APPENDIX B. ABBREVIATIONS.

TIR	test incident reports
TLV	threshold limit value
TM	technical manual
TO	technical order
TOP	test operations procedure
VDLS	VISION Digital Library System
VISION	Versatile Information Systems Integrated ON-line
VOC	volatile organic compound
WDTC	West Desert Test Center

APPENDIX C. REFERENCES.

Required References

1. U.S. Army Test and Evaluation Command (ATEC), Aberdeen Proving Ground (APG), Maryland, Test Operations Procedure (TOP) 08-2-501, Permeation and Penetration Testing of Air-Permeable, Semi-Permeable, and Impermeable Materials with Chemical Agents, 3 March 1997.
2. U.S. Army Dugway Proving Ground (DPG), Utah, Methodology Investigation Report for Simulants for the Protective Equipment Pilot Usability Test and Pilot Agent-Simulant Relationship (ASR) Test For Distilled Mustard (HD); U.S Army Test and Evaluation command (ATEC) Project Number 2006-DT-DPG-CBDPX-D1688, West Desert Test Center (WDTC) Document Number WDTC-MR-07-094, January 2008.
3. U.S. Army Dugway Proving Ground (DPG), Utah, Methodology Investigation Report for the Simulants for Protective Equipment Testing (SPET) Pilot Usability and Agent-Simulant Relationship (ASR) Test for Soman (GD) and Sarin (GB), U.S Army Test and Evaluation Command (ATEC) Project Number 2006-DT-DPG-CBDPX-D1688, West Desert Test Center (WDTC) Document Number WDTC-MR-09-112, May 2009.
4. U.S. Army Dugway Proving Ground (DPG), Utah, Joint Expeditionary Collective Protection (JECPC) Simulant Selection Final Report, U.S Army Test and Evaluation Command (ATEC) Project Number 2008-DT-DPG-JECPX-D8602, West Desert Test Center (WDTC) Document Number WDTC-TR-09-070, January 2011.
5. U.S. Army Test and Evaluation Command (ATEC), Aberdeen Proving Ground (APG), Maryland, Test Operations Procedure (TOP) 08-2-196, Simulant Selection for Laboratory, Chamber, and Field Testing, 25 April 2011.
6. Headquarters, Department of the Army, Washington DC, Pamphlet 385-30, Safety Mishap Risk Management, 1 February 2010.
7. U.S. Army Dugway Proving Ground (DPG), Utah, Methodology Investigation Report for the Novel Closures Test Fixture Test, U.S Army Test and Evaluation Command (ATEC) Project Number 2009-DT-DPG-CBDPX-D1991, West Desert Test Center (WDTC) Document Number WDTC-MR-09-146, December 2009.
8. American National Standards Institute National Conference of Standards Laboratories (ANSI NCSL), Washington, DC, Z540-3, Requirements for the Calibration of Measuring and Test Equipment, National Conference of Standards Laboratories, 1 January 2006.
9. International Organization for Standardization (ISO), Geneva, Switzerland, 10012:2003, Measurement Management Systems – Requirements for Measurement Processes and Measuring Equipment, 1 April 2003.

APPENDIX C. REFERENCES.

10. Headquarters, Department of the Army, Washington DC, U.S. Army Technical Bulletin TB-750-25, Army Test Measurement and Diagnostic Equipment (TMDE) Calibration and Repair Support (C&RS) Program Manual, 1 March 1997.
11. Headquarters, Department of the Navy, U.S. Marine Corps, Washington DC, U.S. Marine Corps Technical Instruction (TI) 4733-OD/1, Calibration Requirements Marine Corps Test, Measurement and Diagnostic Equipment Calibration and Maintenance Program, 31 March 2009.
12. Headquarters, U.S. Air Force, Washington DC, U.S. Air Force Technical Order (TO) 00-20-14, Air Force Metrology and Calibration Program, 30 June 2007.

Standing Operating Procedure References

U.S. ARMY DUGWAY PROVING GROUND (DPG), UTAH,  
STANDING OPERATING PROCEDURE (SOP) PUBLICATIONS

The inclusion of SOPs is only to serve as an example of these type procedures that are used at DPG and as a reference for other installations. Many SOPs are specific to a particular installation, facility, or instrument, and may not be applicable between different installations, facilities, or instruments without modifications. It is expected that each installation will have its own equivalent SOPs. These equivalent SOPs must be provided to the Test & Evaluation (T&E) community interested in this test method in order to properly understand the produced data, any differences between test method application between installations, and therefore the ability to compare data produced by different installations. If an installation does not have an equivalent SOP already in place, these or other similar procedures could be used as temporary guides until appropriate SOPs are developed. The most current version of these SOPs can be requested through ATEC or through access to Versatile Information Systems Integrated Online (VISION) Digital Library System (VDLS).

- A. U.S. Army Dugway Proving Ground (DPG), Utah, Standing Operating Procedure (SOP) DP-0000-M-073, Preparation and Verification Procedures for First Dilution, Stock A, and Working Solutions, Revision 13, Change 1, 12 September 2011.
- B. U.S. Army Dugway Proving Ground (DPG), Utah, Standing Operating Procedure (SOP) DPG SOP DP-0000-M-230, Simulant Dissemination, Revision 7, 13 April 2012.
- C. U.S. Army Dugway Proving Ground (DPG), Utah, Standing Operating Procedure (SOP) WDC-QAC-003R, CHWSF Quality Assurance Program Plan, Revision 3, 3 April 2012.
- D. U.S. Army Dugway Proving Ground (DPG), Utah, Standing Operating Procedure (SOP) WDC-QAC-002, Receipt, Preparation, Analysis, and Reporting of Proficiency Samples, Revision 6, 22 May 2011.

APPENDIX C. REFERENCES.

- E. U.S. Army Dugway Proving Ground (DPG), Utah, Standing Operating Procedure (SOP) WDC-ADM-009, Sample Management, Revision 4, 17 August 2011.
- F. U.S. Army Dugway Proving Ground (DPG), Utah, Standing Operating Procedure (SOP) WDC-ADM-005, Chemical Test Division Reports, Record Keeping, and Data Management, Revision 5, 27 April 2011.
- G. U.S. Army Dugway Proving Ground (DPG), Utah, Standing Operating Procedure (SOP) WDC-ADM-015, Review of Safety Air Monitoring Analytical Data, Revision 4, 15 January 2011.
- H. U.S. Army Dugway Proving Ground (DPG), Utah, Standing Operating Procedure (SOP) WDC-ADM-017, Analytical Method Requirements, Revision 4, 28 February 2011.
- I. U.S. Army Dugway Proving Ground (DPG), Utah, Standing Operating Procedure (SOP) DP-0000-D-216, Preparation, Calibration and Operation of Dissemination Equipment, Revision 8, 7 May 2012.
- J. U.S. Army Dugway Proving Ground (DPG), Utah, Standing Operating Procedure (SOP) WDC-CL-052R, Chemical Agents in DAAMS by GC, Revision 4, 5 January 2012.
- K. U.S. Army Dugway Proving Ground (DPG), Utah, Standing Operating Procedure (SOP) WDC-ANA-032, Analysis of Chemical Agents GA, GD, GF and VX on Solid Sorbent Tubes by Gas Chromatography, Revision 7, 13 April 2012.
- L. U.S. Army Dugway Proving Ground (DPG), Utah, Standing Operating Procedure (SOP) WDC-WIN-009, Work Instruction for the Extraction of Chemical Agent or Simulant from Solid Sorbent Tubes, Revision 4, Revision 5, 21 March 2012.
- M. U.S. Army Dugway Proving Ground (DPG), Utah, Standing Operating Procedure (SOP) WDC-ANA-039, Multicomponent Fourier Transform Infrared (FTIR) Gas Analyzer (GASMET™ DX-4000) Calibration and Operation, Revision 3, 10 January 2012.
- N. U.S. Army Dugway Proving Ground (DPG), Utah, Standing Operating Procedure (SOP) WDC-ANA-034, Near Real-Time Chemical Agent Monitoring, Revision 7, 29 August 2011.
- O. U.S. Army Dugway Proving Ground (DPG), Utah, Standing Operating Procedure (SOP) WDC-CL-044R, Chemical Agent Monitoring (GA, GB, GD, GF, HD, HD, Lewiste, HN-1, HN-3, and VX) Using Field MINICAMS®, Revision 5, 05 January 2012.

TOP 08-2-201  
28 March 2013

(This page is intentionally blank.)

APPENDIX D. APPROVAL AUTHORITY.

CAPAT Cover Sheet

**TEST OPERATION PROCEDURE (TOP) 08-2-201  
COLLECTIVE PROTECTION (COLPRO) NOVEL  
CLOSURES TESTING**

**Decontamination Commodity Area Process Action Team  
(CAPAT)**

Primary Author: Darren Jolley, U.S. Army Dugway Proving Ground (DPG)  
Key Contributors: Tsenu Mamo, Dugway Data Services Team (DDST)  
Henry Thomas, Scot Westwood, DPG

CAPAT Review & Concurrence: October 2012

**Test and Evaluation Capabilities and Methodologies  
Integrated Process Team (TECMIPT) Participants:**









APPENDIX D. APPROVAL AUTHORITY.

CAPAT Signature Sheet

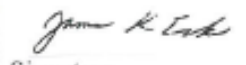
Test Operations Procedures (TOP) 08-2-201 Collective Protection (ColPro) Novel Closures Testing

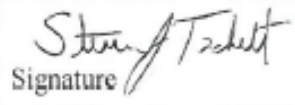
The ColPro CAPAT has completed their review of the Test operations Procedures (TOP) 08-2-201 Collective Protection (ColPro) Novel Closures Testing. The CAPAT recommends approval of this document. If an organization non-concurs, a dissenting position paper will be attached.

<b>Concurrence Sheet for the Test Operations Procedure (TOP) 08-2-201 Collective Protection (ColPro) Novel Closures Testing</b>	
Lt Col Kevin Reilly Marine Corps Operational Test & Evaluation Activity (MCOTEA)	Karen Bowen Joint Program Executive Office for Chemical Biological Defense (JPEO-CBD)
 Signature Date: 22 Oct 12	 Signature Date: 11/5/12
James K. Eck, Colonel USAF Vice Commander, Air Force Operational Test and Evaluation Center (AFOTEC)	Laurie K. Richter, Lt Col, USAF Joint Requirements Office (JRO) for Chemical, Biological, Radiological, and Nuclear Defense
 Signature Date: 4 Sep 12	 Signature Date: 27 Oct 12
Jeffrey Bobrow Assistant Chief of Staff, Expeditionary Warfare Commander Operational Test and Evaluation Force (COMOPTEVFOR)	Deborah Shuping Deputy Undersecretary of the Army, Test and Evaluation (DUSA TE)
 Signature Date: 25/1/12	 Signature Date: 8/16/12
Steve Tackett US Army Test and Evaluation Command (ATEC)/U.S. Army Evaluation Command (AEC)	Michael Roberts Joint Science and Technology Office (JSTO)
 Signature Date: 16 July 2012	 Signature Date: 5 Sep 2012

**NOTE:** CAPAT member's signature represents an O6 level concurrence from their organization. If the CAPAT representative is not empowered at this level, he/she must coordinate the concurrence/nonconcurrence process within his/her organization, and prior to the specified suspense date for the document.

APPENDIX D. APPROVAL AUTHORITY.

T&E Capabilities and Methodologies Integrated Process Team (TECMIPT) Chair Endorsement

AMXAA-CD

8 April 2013

MEMORANDUM FOR

Chemical, Biological, Radiological and Nuclear Defense (CBRND) Test and Evaluation (T&E) Executive, Office of the Deputy Under Secretary of the Army, Taylor Building, Suite 8070, 2530 Crystal Drive, Arlington, VA 22202

SUBJECT: Test and Evaluation Capabilities and Methodologies Integrated Process Team (TECMIPT) Test Operations Procedure (TTOP) 08-2-201 Collective Protection (ColPro) Novel Closures Testing

1. The Collective Protection Capability Area Process Action Team (CAPAT) has completed their review of the subject TTOP in accordance with the DUSA-TE Instructions to the TECMIPT, the Standards and Development Plan, and the TECMIPT Standard Operating Procedure (SOP). All signatory members of the CAPAT have provided their concurrence to this TTOP (enclosed). The CAPAT signature sheets and the ATEC Approval for Publication memorandum are enclosed.
2. Based on the concurrence of the CAPAT, I recommend the CBRND T&E Executive endorse this TTOP as a Department of Defense (DoD) Test and Evaluation (T&E) Standard.

Encl

  
RONALD O. PRESCOTT  
TECMIPT Chair

APPENDIX D. APPROVAL AUTHORITY.

Deputy Under Secretary of the Army Endorsement



**DEPARTMENT OF THE ARMY**  
OFFICE OF THE DEPUTY UNDER SECRETARY OF THE ARMY  
102 ARMY PENTAGON  
WASHINGTON, DC 20310-0102

DUSA-TE

MEMORANDUM FOR DISTRIBUTION

SUBJECT: Endorsement of TECMIPT Test Operations Procedure (TTOP) 08-2-201, Collective Protection (ColPro) Novel Closures Testing

1. Reference: Memorandum, DUSA-TE, 19 July 10, subject: Chemical and Biological Defense Program (CBDP) Test and Evaluation (T&E) Standards Development Plan
2. TTOP 08-2-201 was developed, coordinated, and approved by the members of the ColPro Capability Area Process Action Team (CAPAT) in accordance with the reference. The U.S. Army Test and Evaluation Command (ATEC) approved according to their TOP approval process.
3. I endorse this TTOP as a DoD T&E Standard for Collective Protection testing and encourage its broad use across all test phases. All T&E Standards are for government associated program access and use. They are stored in Army Knowledge Online (AKO), in the TECMIPT Share point site and on the National Institute of Standards and Technology (NIST) website at <http://gsi.nist.gov/global/index.cfm/L1-4/L2-19/A-664>.
4. My point of contact for this action is Ms. Deborah Shuping, (703) 545-1119, [deborah.f.shuping.civ@mail.mil](mailto:deborah.f.shuping.civ@mail.mil).

Encl

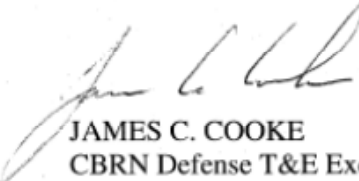
  
JAMES C. COOKE  
CBRN Defense T&E Executive



(This page is intentionally blank.)

TOP 08-2-201  
28 March 2013

Forward comments, recommended changes, or any pertinent data which may be of use in improving this publication to the following address: Range Infrastructure Division (CSTE-TM), U.S. Army Test and Evaluation Command, 2202 Aberdeen Boulevard, Aberdeen Proving Ground, Maryland 21005-5001. Technical information may be obtained from the preparing activity: Director, West Desert Test Center, U.S. Army Dugway Proving Ground, ATTN: TEDT-DPW, Dugway, UT 84022-5000. Additional copies can be requested through the following website: <http://itops.dtc.army.mil/RequestForDocuments.aspx>, or through the Defense Technical Information Center, 8725 John J. Kingman Rd., STE 0944, Fort Belvoir, VA 22060-6218. This document is identified by the accession number (AD No.) printed on the first page.