

REPORT DOCUMENTATION PAGE

Form Approved
OMB No. 0704-0188

The public reporting burden for this collection of information is estimated to average 1 hour per response, including the time for reviewing instructions, searching existing data sources, gathering and maintaining the data needed, and completing and reviewing the collection of information. Send comments regarding this burden estimate or any other aspect of this collection of information, including suggestions for reducing this burden, to Department of Defense, Washington Headquarters Services, Directorate for Information on Operations and Reports (0704-0188), 1215 Jefferson Davis Highway, Suite 1204, Arlington, VA 22202-4302. Respondents should be aware that notwithstanding any other provision of law, no person shall be subject to any penalty for failing to comply with a collection of information if it does not display a currently valid OMB control number.
PLEASE DO NOT RETURN YOUR FORM TO THE ABOVE ADDRESS.

1. REPORT DATE (DD-MM-YYYY) 03-07-2013		2. REPORT TYPE Final		3. DATES COVERED (From - To)	
4. TITLE AND SUBTITLE Test Operations Procedure (TOP) 08-2-066A Aerosol Testing of Biological Point Detection Systems			5a. CONTRACT NUMBER		
			5b. GRANT NUMBER		
			5c. PROGRAM ELEMENT NUMBER		
6. AUTHORS			5d. PROJECT NUMBER		
			5e. TASK NUMBER		
			5f. WORK UNIT NUMBER		
7. PERFORMING ORGANIZATION NAME(S) AND ADDRESS(ES) US Army Dugway Proving Ground West Desert Test Center (TEDT-DPW-LSA) Dugway, UT 84022-5000				8. PERFORMING ORGANIZATION REPORT NUMBER TOP 08-2-066A	
9. SPONSORING/MONITORING AGENCY NAME(S) AND ADDRESS(ES) US Army Test and Evaluation Command CSTE-TM (Range Infrastructure Division) 2202 Aberdeen Boulevard Aberdeen Proving Ground, MD 21005-5001				10. SPONSOR/MONITOR'S ACRONYM(S)	
				11. SPONSOR/MONITOR'S REPORT NUMBER(S) Same as item 8	
12. DISTRIBUTION/AVAILABILITY STATEMENT Öã dã ç } Áæ { } ÖËÖ] ç^áÁ Á ~ à áÁ^æ^Áã dã ç } Á Á } ã æ^áÈ ÁÁ ÁÁ					
13. SUPPLEMENTARY NOTES Defense Technical Information Center (DTIC), AD No.: This TOP supersedes TOP 08-2-066, Biological Detector, Aerosol, dated 28 May 1997. Marginal notations are not used in this revision to identify changes, with respect to the previous issue, due to the extent of the changes.					
14. ABSTRACT This TOP provides standard procedures for designing and conducting chamber tests involving the aerosolization of biological warfare agents (BWAs) and simulants.					
15. SUBJECT TERMS Containment Aerosol Chamber; CAC; Ambient Breeze Tunnel; ABT; Aerosol Simulant Exposure Chamber; ASEC; Whole System Live Agent Test; WSLAT; Joint Biological Point Detection System; JBPDS; agent of biological origin; ABO; biosafety level; BSL					
16. SECURITY CLASSIFICATION OF:			17. LIMITATION OF ABSTRACT	18. NUMBER OF PAGES 87	19a. NAME OF RESPONSIBLE PERSON
a. REPORT Unclassified	b. ABSTRACT Unclassified	c. THIS PAGE Unclassified			19b. TELEPHONE NUMBER (include area code)
			SAR		

US ARMY TEST AND EVALUATION COMMAND
TEST OPERATIONS PROCEDURE

*Test Operations Procedure 08-2-066A
Accession Number (DTIC AD. No.)

3 July 2013

AEROSOL TESTING OF BIOLOGICAL POINT DETECTION SYSTEMS

	<u>Page</u>
PARAGRAPH 1. SCOPE.....	3
1.1 Purpose.....	3
1.2 Application.....	3
1.3 Limitations.....	3
2. FACILITIES AND INSTRUMENTATION.....	4
2.1 Facilities.....	4
2.2 Instrumentation.....	9
3. REQUIRED TEST CONDITIONS.....	18
3.1 Preparations for Test.....	18
3.2 Safety.....	18
3.3 Environmental Analysis.....	19
3.4 Instrument Calibration.....	19
3.5 Chamber/Facility Preparations.....	19
3.6 Pre-Test Reviews.....	20
3.7 Data Quality Control (QC).....	20
3.8 Operations Security (OPSEC).....	21
4. TEST PROCEDURES.....	21
4.1 Purpose.....	21
4.2 Biological Material Production.....	21
4.3 Aerosol Chamber Testing.....	21
4.4 CAC Preparations and Trial Execution.....	22
4.5 ASEC Preparations and Trial Execution.....	23
4.6 ABT Preparation and Test Execution.....	25
4.7 Retrograde Operations.....	25
5. DATA REQUIRED.....	26
6. PRESENTATION OF DATA.....	26
6.1 General.....	26
6.2 Data Management.....	27
6.3 Types of Data Obtained from the Referee Instrumentation.....	27
6.4 Types of Biological Point Detection Systems.....	28

*This TOP supersedes TOP 08-2-066, dated 14 August 1996.

Approved for public release; distribution is unlimited

3 July 2013

	<u>Page</u>
APPENDIX	
A. PARTICLE GENERATION AND DISSEMINATION PROCEDURES WITH SLURRIES OF BIOLOGICAL MATERIAL.....	A-1
B. REFEREE INSTRUMENTATION DATA REDUCTION AND CONVERSION.....	B-1
C. AEROSOL SIMULANT EXPOSURE CHAMBER (ASEC) CONFIGURATION.....	C-1
D. ABBREVIATIONS.....	D-1
E. REFERENCES	E-1
F. APPROVAL AUTHORITY	F-1

Approved for public release; distribution is unlimited.

1. SCOPE.

1.1 Purpose.

a. This test operations procedure (TOP) provides guidelines for designing and conducting chamber and Ambient Breeze Tunnel (ABT) tests involving the aerosolization of biological warfare agents (BWAs) and simulants, and for collecting referee data using currently available referee equipment.

b. Procedures in this TOP apply to testing with BWAs and simulants only at U.S. Army Dugway Proving Ground (DPG), Utah.

1.2 Application.

Test procedures in this TOP define a methodology to test the performance of biological point detection systems and their components. These procedures were developed during Phases I and II of the Whole-System Live Agent Test (WSLAT) at DPG from 2005 through December 2010^{1,2**}. During WSLAT Phases I and II, representatives from each of the four classes of BWAs/biological materials (bacterial spores, vegetative bacteria, viruses, and toxins) were tested. The information presented in this TOP is based on methodologies developed during testing of those selected biological materials^{1,2}.

1.3 Limitations.

a. Some of the referee equipment described in this TOP cannot be used in all of the aerosol test chambers available at DPG because of environmental conditions or physical constraints. Equipment limitations and chamber incompatibility are defined in the instrumentation and equipment descriptions (Paragraph 2.2).

b. The techniques described in this TOP for electrochemiluminescence (ECL) and polymerase chain reaction (PCR) analysis have a quantification resolution of one order of magnitude; i.e., the bacterial genome count or toxin concentration for a particular analyzed sample can be ± 10 times the reported value.

c. WSLAT Phases I and II involved wet dissemination in the Containment Aerosol Chamber (CAC), Aerosol Simulant Exposure Chamber (ASEC), and ABT; therefore, test procedures described in this TOP are for wet dissemination only.

**Superscript numbers and letters correspond to those in Appendix E.

3 July 2013

2. FACILITIES AND INSTRUMENTATION.2.1 Facilities.

The test procedures described in this TOP apply to three biological aerosol test fixtures available at DPG; the CAC, the ASEC, and the ABT. The CAC and the ASEC are indoor chambers located at the Life Sciences Test Facility (LSTF), DPG. The ABT is outdoors, located on DPG's test range.

<u>Item</u>	<u>Requirement</u>
CAC	Contains aerosolized biosafety level (BSL)-3 agents of biological origin (ABOs).
ASEC	Contains aerosolized simulant or BSL-1 agent-like organisms (ALOs)-Inactivated (I).
ABT	Contains aerosolized BSL-1 ALOs-I.
BSL-1, BSL-2, and/or BSL-3 biological laboratories	<p>Must be constructed to ensure safe and secure storage, handling, analysis, and decontamination of microbial agents and/or simulants used for test and evaluation (T&E). A surety facility may be required for testing, depending on the strain of organism used.</p> <p>Required to prepare and store test quantities of biological simulant materials, to provide general support needed for work with microbial agents (e.g., to charge disseminating devices, sampler preparation, etc.), and to provide general and specialized biological analysis support for all biological agents or simulants used.</p> <p>Will have appropriate emergency response provisions and hazardous waste storage and disposal procedures.</p> <p><u>NOTE:</u> The BSL laboratory requirements will depend on the type of organism under test.</p>
Class II biological safety cabinet (BSC) for biological materials	Must meet the biological safety requirements for working with microbial agents and be operated according to all local standing operating procedures (SOPs). Biological surety regulations will be followed, as required.

3 July 2013

ItemRequirement

Must be equipped with an air intake and an exhaust system that moves effluent air through high-efficiency particulate air (HEPA) filters (capable of retaining 99.97 percent of particles 0.3 μm or greater in diameter) and into a second exhaust system.

2.1.1 CAC.

a. The CAC is a stainless steel chamber designed for BWA exposure of a test item in a BSL-3 environment (Figure 1). The dimensions of the CAC are approximately $4.24 \times 1.96 \times 1.16$ m (L \times W \times H) with a volume of ~ 9.64 m³. The CAC is also equipped with glass observation windows, one 110 \times 110-cm access door, and one 27.3-cm diameter rapid transfer port for transfer of materials (e.g., consumables and samples) in or out of the CAC. An autoclave is integrated with the CAC for sterilization of biological waste generated within the chamber. Glove ports and half-suits are installed at select locations to allow personnel to safely access and manipulate equipment within the chamber. The CAC is equipped with electrical outlets and filtered, compressed air. Access ports for power, communication, and other cables or tubing are available as needed. Items being tested in the CAC are normally placed within a sub-compartment of the CAC known as the detector challenge chamber (DCC).

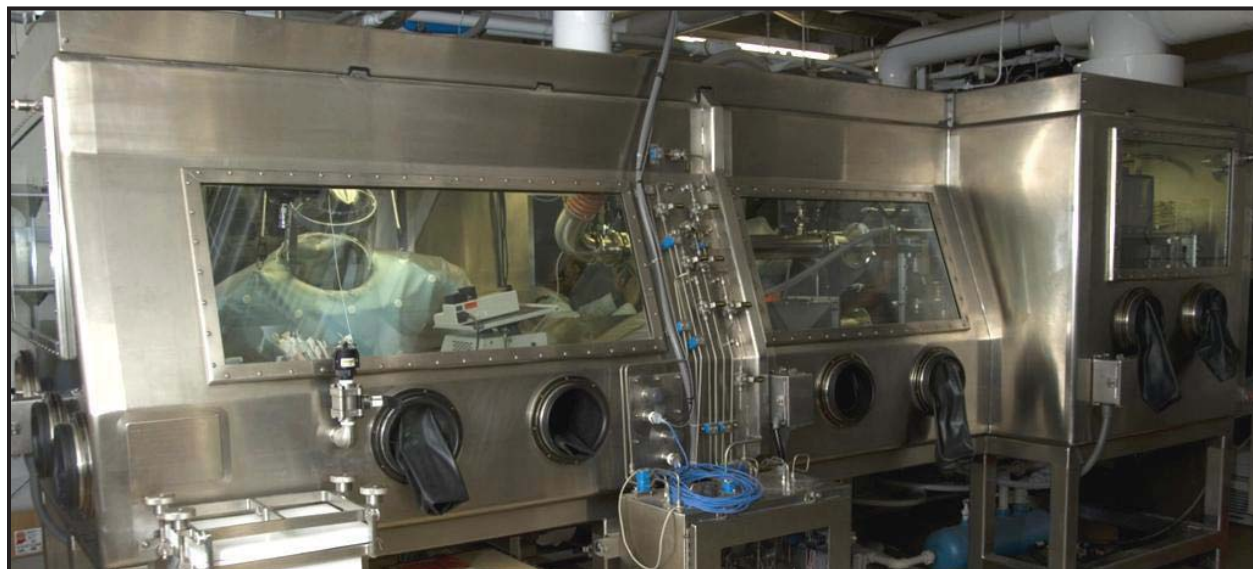
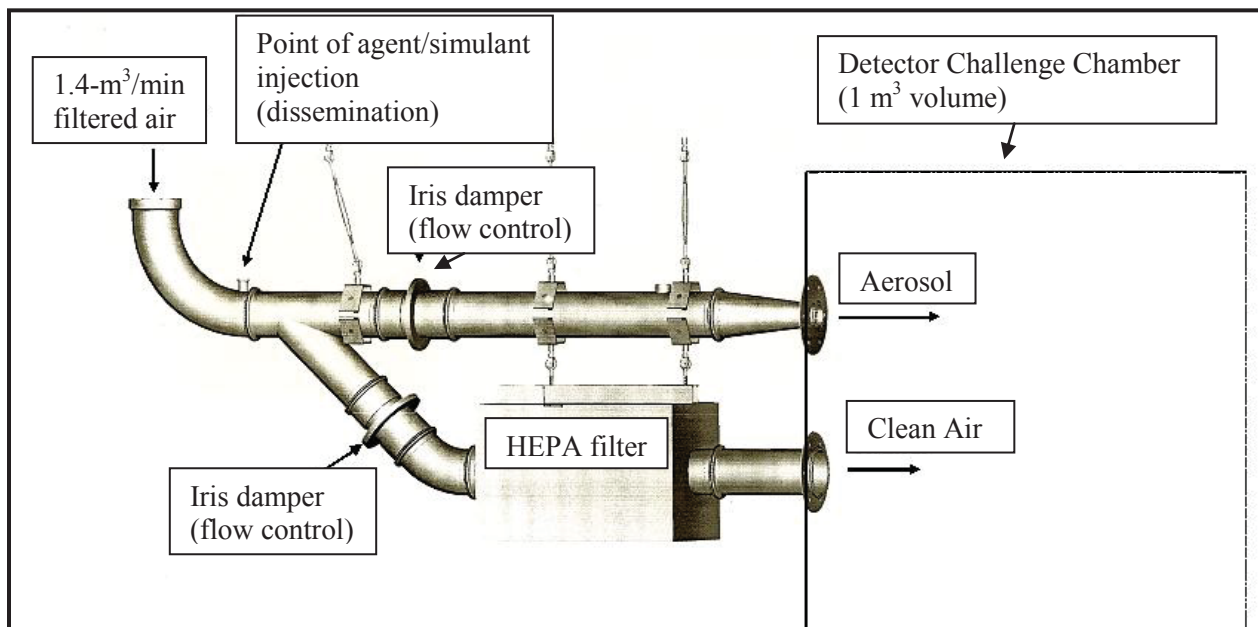

Figure 1. Containment aerosol chamber (CAC).

3 July 2013

b. The DCC is a 1-m³ glove box constructed of 1.27-cm thick Lexan[®] [Saudi Basic Industries Corporation (SABIC) Innovative Plastics (formerly General Electric Plastics), Pittsfield, Massachusetts]* in which test items are placed and exposed to aerosols (Figures 2 and 3). Aerosol sampling ports for an Aerodynamic Particle Sizer[®] (APS[™], TSI Inc., Shoreview, Minnesota) and an all-glass impinger (AGI) are incorporated into the DCC. A slit-to-agar (STA) sampler is located inside the DCC. The aerosol in the DCC is exhausted through a 10-cm diameter port fitted on the wall of the DCC. Temperature and humidity probes are installed through the wall of the DCC on the same side as the sampling ports.



NOTE: HEPA – high-efficiency particulate air.

Figure 2. Schematic diagram of the challenge aerosol delivery system for the detector challenge chamber (DCC).

*The use of brand names does not constitute endorsement by the Army or any other agency of the Federal Government, nor does it imply that a brand-named item is best suited among similar items for the intended application.

3 July 2013

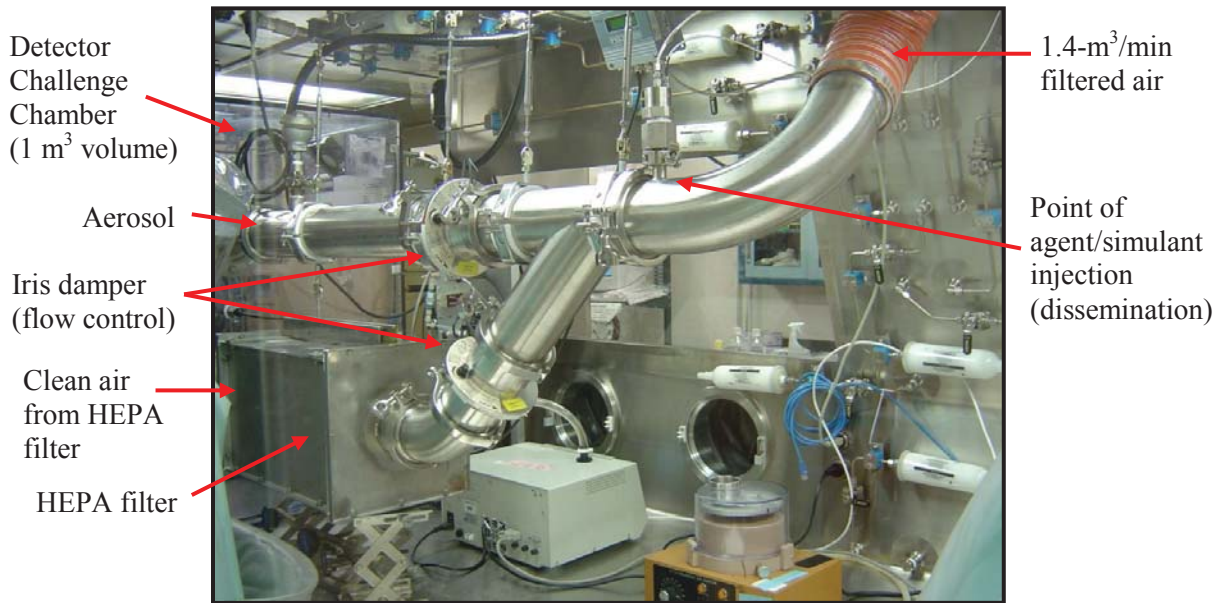

NOTE: HEPA – high-efficiency particulate air.

Figure 3. Challenge aerosol delivery system for the detector challenge chamber (DCC).

c. The DCC operates at ambient temperature and relative humidity (RH). The air pressure differential between the DCC and CAC and between the interior and exterior of the CAC are continuously monitored and adjusted using a computer to ensure that the air pressure in outer areas is always positive with respect to the pressure in inner areas. The minimum and maximum aerosol concentrations that can be achieved in the DCC, as reported by an APSTM, are 15 ± 10 agent-containing particles per liter of air (ACPLA) and $12,500 \pm 250$ ACPLA, respectively, using a Sono-Tek nozzle (Sono-Tek Corporation, Milton, New York) based on an airflow of 50 cubic feet per minute (CFM). Additional information is in Appendix A. Referee instrumentation described in this TOP includes an XMX high-volume aerosol multisample collector, Model 2L-102 (XMX, Dycor Technologies Ltd., Edmonton, Alberta, Canada), STA sampler, AGI, and APSTM (Appendix B); however, other referee instrumentation may be used, depending on the test requirements.

2.1.2 ASEC.

a. The ASEC is a stainless steel-lined chamber designed for simulant aerosol exposure of test items in a BSL-1 environment (Figure 4). The interior dimensions of the ASEC are $5 \times 5 \times 3$ m (L \times W \times H) with a volume of 75 m³. The interior of the ASEC is accessible to personnel through an airlock. Tubing and cables can be passed through four, 2.5-cm and six, 3.8-cm ports connected to the chamber walls. The chamber is operated with a static/low airflow at a rate of approximately 50 CFM, which is the minimum airflow required to maintain the negative air pressure differential inside the chamber with respect to the outside. A Sono-Tek nozzle located

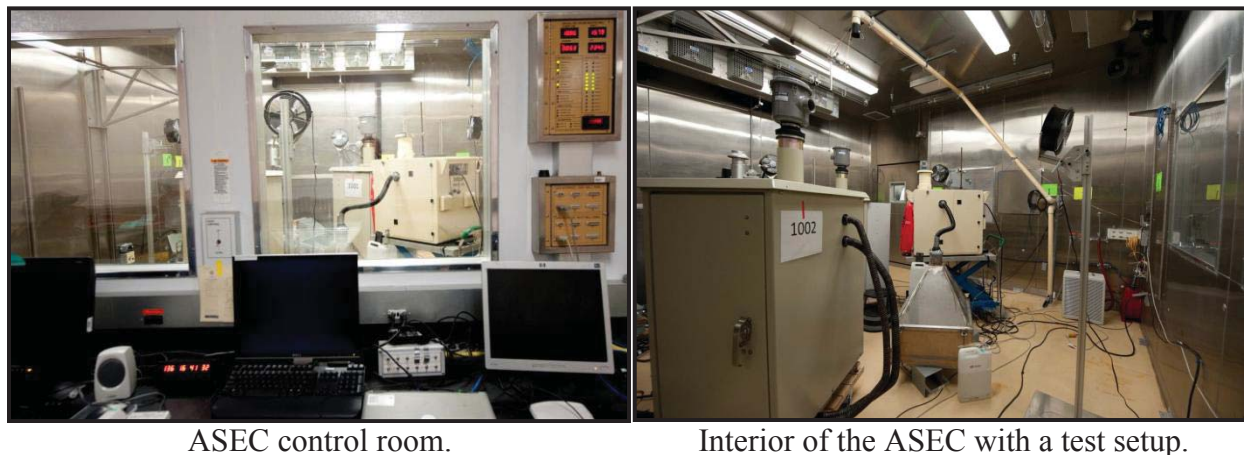

Figure 4. Aerosol simulant exposure chamber (ASEC).

in the chamber is used to aerosolize the biological challenge material. A set of four, free-standing 25.4-cm fans centrally located along the base of each wall are used to mix the aerosol inside the chamber. Intake and exhaust air are cleaned by HEPA filters. Portable HEPA filters inside the ASEC can be used to further reduce environmental particles before dissemination, or to remove the challenge aerosol after dissemination. Temperature can be controlled between 0° and 40°C, and humidity is ambient inside the chamber.

b. Compressed air lines, vacuum lines, and 120-volt (V) programmable electrical outlets are available inside the chamber for the systems under test (SUTs) and referee instrumentation. The chamber has two windows (one each in the front and right walls) for observing the interior of the challenge area. Resources outside the chamber include bench space for desktop computers, samplers, the APST™, aerosol injection system, and other instrumentation. The minimum and maximum achievable particle concentrations, as reported by an APST™, are 30 ± 15 ACPLA and $37,800 \pm 250$ ACPLA, respectively. Referee instrumentation includes the XMX, STA sampler, AGI, and APST™ (Appendix B); however, other referee instrumentation may be used depending on the test requirements. The detailed configuration for the ASEC is described in Appendix C.

2.1.3 ABT.

a. The ABT is an outdoor wind tunnel test fixture (Figure 5) designed for simulant aerosol exposure of test items and interferents in a BSL-1 environment. The dimensions of the ABT are $46 \times 6 \times 6$ m (L \times W \times H) with a volume of 1656 m^3 . The ABT is designed with the following capabilities: delivery of homogeneous aerosols in ambient air to the test and referee systems, characterization of cloud concentrations over time, minimization of aerosol releases into the environment, and minimization of the external meteorological conditions on internal ABT wind conditions. Of the facilities mentioned in this TOP, only the ABT can handle dry dissemination.



Figure 5. Ambient breeze tunnel (ABT).

b. The ABT has an adjacent aerosol generation control room that is used by operators during trials. A temperature-controlled trailer outside of the ABT can accommodate test personnel, and provides bench space for referee and test data collection computers. The inside of the tunnel is equipped with multiple electrical outlets for supplying power to test systems and referee instrumentation.

c. Referee measurements in the outdoor test fixtures can be made by comparing the particle-size distributions of the generated challenge aerosol with those of the background particles to ensure that the challenge particles are larger than the background particles. The ambient background particles are generally smaller than 1 micron; therefore, the challenge aerosol particulate size must be significantly larger so that it is easy to differentiate between challenge and background particles. The achievable aerosol concentration, as reported by an APSTM, is approximately 100 ± 50 to $25,000 \pm 250$ ACPLA using the Sono-Tek nozzle at a wind speed of 1 m/sec. Increasing wind speed will decrease ACPLA proportionally. The maximum wind speed achievable at the ABT is 6 m/sec. Referee instrumentation includes XMX, STA, AGI, and APSTM (Appendix B); however, other referee instrumentation may be used depending on the test requirements.

2.2 Instrumentation.

2.2.1 Accuracy Required for Instrumentation.

<u>Parameter</u>	<u>Measuring Device</u>	<u>Permissible Error of Measurement</u>
Liquid volume	Pipette	± 0.5 mL
Mass	Digital scale	± 0.1 mg
Time	Digital clock.	± 1 sec

<u>Parameter</u>	<u>Measuring Device</u>	<u>Permissible Error of Measurement</u>
Temperature	Thermometer, thermocouple, or equivalent.	±0.1°C.
Wind speed	Anemometer or equivalent.	±0.5 m/sec.
RH	Humidity sensor, probe, or equivalent.	±0.1 percent.
Aerosol particle size	Particle sizers, such as APS™ units or equivalent.	±0.5 µm.
Aerosol particle number	Particle counters, such as APS™ units, STA samplers, or equivalent.	±10 percent number of particles per L of air.
Agent-containing particles (culturable)	STA sampler.	±10 percent number of particles per L of air.
Biomaterial (bacteria, virus, toxin)	AGI or XMX.	±10 percent of quantity of biomaterial per L of air.
Contamination measurement	Assay-dependent.	Report any contamination. Permissible error is assay-dependent.
Test images (Images of typical test procedures, test events, dissemination techniques, contamination density and any discrepancies from planned procedures)	Digital still and video cameras.	Not applicable.

2.2.2 Devices for Characterizing Challenge Aerosols in the Test Chambers.

a. XMX.

(1) In the ASEC and ABT, the XMX (Figure 6) can be used as the primary collection system for simulants (for bacteria, viruses, and toxins), and the secondary collection system for viable *Bacillus atrophaeus* (BG) spores (the primary collection for BG spores is the STA sampler). The XMX should be operated in accordance with (IAW) the operator's manual³. **NOTE:** The XMX cannot be used in the CAC because the CAC has insufficient volume space and air-flow.



Figure 6. XMX/2L-102 high-volume sampler (left) and sample tube carousel (right).

(2) The liquid in the XMX sample is typically phosphate-buffered saline (PBS) with approximately 9 ± 0.3 mL per sample vial; however, other sterile diluents may be used depending on the aerosol simulant being collected.

(3) Sample times may be varied from 1 to 10 min for each sample.

(4) The XMX draws approximately 600 L of air/min.

(5) Although the XMX was used during WSLAT Phases I and II^{1,2}, it should be noted that the XMX had a problem with sample carryover and the results obtained were not a true reflection of actual data.

b. STA Sampler.

(1) The STA sampler (Figure 7), a Mattson-Garvin Model 220 air sampler (Mattson-Garvin, Homosassa, Florida) or equivalent is used as the primary aerosol sampler for viable bacterial spores in the CAC, ASEC, and ABT. Some STA sampler models require a separate vacuum source, and other models have the vacuum source built in; the motor may or may not have more than one speed. A required specification is the capability to accept a 150-mm diameter Petri plate containing an appropriate sterile, solid, growth medium. An air sample is drawn through a slit on the thimble mounted on top of the cover. Particles in the air sample possessing sufficient momentum impact the surface of the moist, solid, growth medium and become immobilized. After sampling, the plate is incubated and the colonies counted. Each colony represents a particle containing at least one culturable bacterium. STA samplers may be run in sequence using a vacuum sequencer and Dycor Technologies software.



Figure 7. Mattson-Garvin model 220 slit-to-agar (STA) sampler.

(2) The maximum aerosol concentration should not exceed 80 ACPLA when using an STA sampler with a rotational speed of 1 revolution per 2 minutes; otherwise, particle overlapping will occur on the sampler's agar surface, making quantification difficult. A time-concentration relationship can be calculated. When ambient temperatures are below 8°C, the agar surface around the aerosol inlet may freeze. Operation of the STA sampler is described in DPG SOP WDL-WI-AER-205⁴.

NOTE: Vegetative bacterial cells cannot withstand impaction and cannot be accurately assayed by STA sampling. Toxins and viruses cannot be quantified with an STA sampler.

c. AGI.

(1) The AGI (Figure 8), Model 7540 (Ace Glass Incorporated, Vineland, New Jersey) or equivalent, is used as the primary collection tool in the CAC, ASEC, and ABT for BWAs that are vegetative bacteria, viruses, and toxins, as well as bacterial, viral, and toxin simulants. The AGI is used as a secondary collection for viable bacterial spores.

(2) An AGI sample can be collected at a nominal flow rate of 12.5 L/min for various time intervals. The typical duration of sample collection is 2 to 5 min.

(3) AGIs are typically run in sequence using a vacuum sequencer and Dycor Technologies software. For biological aerosol testing, 20 mL (per AGI) of PBS is used as the collection medium; however, other sterile diluents may be used depending on the challenge aerosol being collected. Collected samples may be assayed with various laboratory techniques, depending on the test requirements, including PCR and ECL analysis and plating or plaque assays of viable materials.

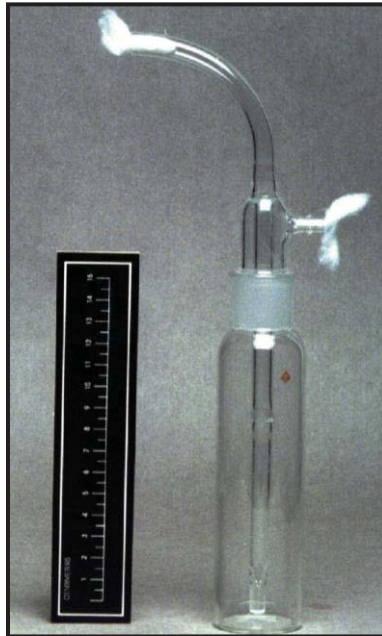

Figure 8. Example of an all-glass impinger (AGI).

(4) AGI Limitations. There are several limitations in the use of the AGI.

(a) There is a reduction in viability of AGI-collected vegetative cells. The reduction in viability of samples is caused by physical damage to the cells during sample collection.

(b) The data are not time-resolvable, and only one data point is obtained for each sample.

(c) The liquid within the AGI is subject to freezing under some adverse combinations of sampling time and ambient temperature. The test officer (TO) may elect to place the AGI in a heated rack when adverse conditions are present.

(5) The procedure for AGI use is in DPG SOP WDL-WI-AER-212⁵.

d. APSTTM.

(1) The APSTTM Model 3321 (TSI Inc., Shoreview, Minnesota) (Figure 9), is used to monitor particle size and concentration of particles per mL of sampled air.

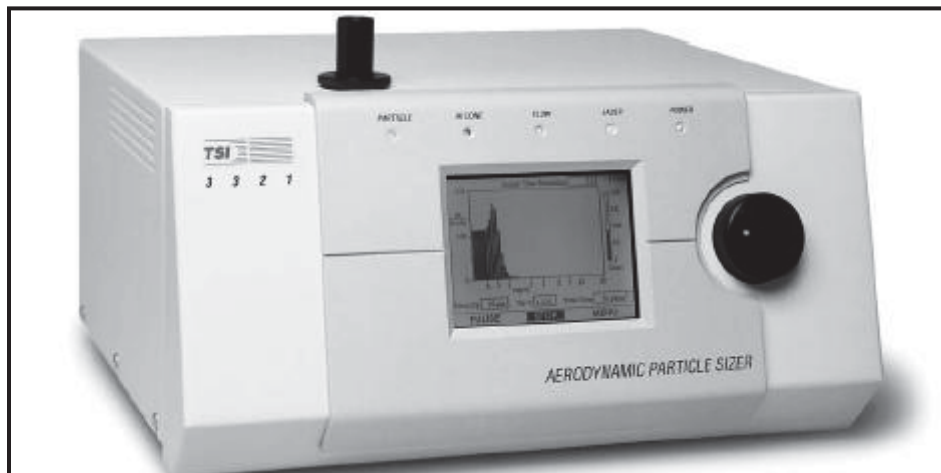

Figure 9. Aerodynamic particle sizer[®] (APSTM) unit.

(2) Data generated by the APSTM are used to determine aerodynamic particle size and physical particle counts. The APSTM monitors particles up to 20 μm in aerodynamic diameter at concentrations from 1 to 1,000 particles/mL air with a coincidence error of less than 10 percent. APSTM test data are saved to an electronic file.

(3) The APSTM is typically configured to operate continuously, taking an aerosol sample every 6 seconds to determine aerosol concentration versus time. Each year, the APSTM is calibrated IAW the procedures in DPG SOP WD-WI-AER-203⁶ to ensure that it is operating within manufacturer specifications.

(4) All sample lines will be isokinetic, and conductive sample tubing lengths (not to exceed 2 m) will be shortened to minimize particle loss.

- e. The suggested quantity of standard referee instrumentation per fixture is in Table 1.
- f. The CAC referee instrumentation for BWA simulant aerosols is in Table 2.
- g. The ASEC and ABT referee instrumentation for BWA simulant aerosols is in Table 3.

2.2.3 Generation of Near-Monodispersed Challenge Aerosols.

The Sono-Tek ultrasonic spray nozzle system (Model 8700-60) is the standard aerosol generator for chamber testing. The Sono-Tek generates near-monodispersed droplets from liquid slurries (particle suspension) which dry down to particles with the desired number median aerodynamic diameter (NMAD). By adjusting the slurry composition, dried-down particles in the range of 2- to 6- μm NMAD can be obtained. A syringe infusion pump is employed to deliver the slurry to the nozzle and an agitator is used to prevent settling of the solid material in the slurry during delivery to the nozzle.

Table 1. SUGGESTED QUANTITY OF STANDARD REFEREE INSTRUMENTATION PER FIXTURE.

Referee Instrument ^a	CAC ^b	ASEC ^c	ABT ^d
APST TM	1	1	2
AGI	1	3	4
STA sampler (2-min)	1	3	4
XXM	NA ^e	1	1

^aAPSTTM – Aerodynamic Particle Sizer[®] (TSI Inc., Shoreview, Minnesota); AGI – all-glass impinger; STA – slit-to-agar; XXM – XXM high-volume aerosol multisample collector (Dycor Technologies Ltd., Edmonton, Alberta, Canada).

^bContainment Aerosol Chamber.

^cAerosol Simulant Exposure Chamber.

^dAmbient Breeze Tunnel.

^eNot applicable.

NOTE: The quantity and types of referee instrumentation and sample collection time per referee instrument will depend on the test requirements.

Table 2. CONTAINMENT AEROSOL CHAMBER (CAC) AND REFEREE INSTRUMENTATION FOR BIOLOGICAL WARFARE AGENT (BWA) AEROSOLS.

Chamber	Referee ^a	BWA			
		Bacterial Spores	Vegetative Bacteria	Viruses	Toxins
CAC ^b	APST TM	Yes	Yes	Yes	Yes
	AGI	Yes	Yes	Yes	Yes
	STA sampler	Yes	NA ^c	NA	NA

^aAPSTTM – Aerodynamic Particle Sizer; AGI – all-glass impinger; STA – slit-to-agar.

^bContainment Aerosol Chamber.

^cNot applicable.

Table 3. AEROSOL SIMULANT EXPOSURE CHAMBER (ASEC) AND AMBIENT BREEZE TUNNEL (ABT) REFEREE INSTRUMENTATION FOR BIOLOGICAL WARFARE AGENT (BWA) AND SIMULANT AEROSOLS.

Referee ^a	BG ^b (wet) ^c	BG-I ^d (wet)	Bacterial Spores (wet)		Vegetative Bacteria (wet)		Viruses (wet)		Toxins (wet)	
			ALO ^e	ALO-I ^f	ALO	ALO-I	ALO	ALO-I	ALO	ALO-I
APSTM	Yes	Yes	Yes	Yes	Yes	Yes	Yes	Yes	Yes	Yes
AGI ^g	Yes	Yes	Yes	Yes	Yes	Yes	Yes	Yes	Yes	Yes
STA sampler	Yes	NA ^h	Yes	NA	Yes	NA	NA	NA	NA	NA
XXM ⁱ	Yes	Yes	Yes	Yes	Yes	Yes	Yes	Yes	Yes	Yes

^aAPSTM – Aerodynamic Particle Sizer (TSI Inc., Shoreview, Minnesota); AGI – all-glass impinger; STA – slit-to-agar; XMX – XMX high-volume aerosol multisample collector (Dycor Technologies Ltd., Edmonton, Alberta, Canada).

^bBG – *Bacillus atrophaeus*.

^cInformation in this test operation procedure (TOP) is based on the WSLAT Phases I and II tests^{1,2} that used only wet challenge materials; however, the referee instruments are also capable of measuring dry challenge materials.

^dInactivated BG.

^eAgent-like organism.

^fInactivated ALO.

^gLimitations in the use of the AGI include a reduction in viability for collected vegetative cells caused by physical damage to the cells during sample collection. The AGI data are not time-resolvable, and only one data point is obtained for each sample. The liquid within the AGI is subject to freezing under some adverse combinations of sampling time and ambient temperature.

^hNot applicable.

ⁱThe XMX cannot be used in the CAC because the CAC has insufficient volume space and airflow. It should be noted that the XMX had a problem with sample carryover during the WSLAT Phases I and II tests^{1,2}, and the results obtained were not a true reflection of the actual data.

NOTE: Of the test facilities mentioned, only the ABT can accommodate dry material dissemination.

2.2.4 Assay of BWA and Simulant Samples.

Standard microbiological assay procedures will be employed to quantify the number of colony forming units (CFU), plaque forming units (PFU), and mass per volume. The type of challenge material (bacteria, virus, or toxin) dictates which assay procedure and/or analytical instruments will be used. Assay procedures are described in the Conformance Test section for each biological material in WDL-HBK-BIO-001⁷.

2.2.5 Meteorological Measurements.

Meteorological sensors will be used in the ABT to characterize the wind speed, wind direction, temperature, and RH at the location of the SUT.

2.2.6 Other Test Instrumentation.

a. Still and video cameras will be used for documenting test items, test events, and procedures.

b. Automated data collection and processing systems will be used for collecting data in real time at the frequency and precision necessary for data sufficiency.

c. ECL Instrumentation and Assays.

(1) The LSTF uses the BioVeris M-Series M1-R Analyzer Detection System (BioVeris Corporation, Gaithersburg, Maryland), or equivalent, to test collected samples for the presence of a biological toxin. This ECL instrumentation includes minitube immunoassays on a plate platform. The ECL will be operated and assays performed IAW DPG SOP WDL-WI-BIO-097⁸.

(2) ECL assay technology uses lyophilized (freeze-dried) sandwich minitube immunoassays. One antibody, specific for the toxin to be measured, is immobilized on micro particles. The other antibody is labeled with BioVeris' BV-TAG™ label. The sample is mixed with these two antibodies. When the specific toxin to be measured is present in the sample, both antibodies bind to it, linking together the microparticles, the organism, and BV-TAG™ label. The reaction mixture is then transported with an assay buffer to a flow cell with an electrode which stimulates the bound BV-TAG™ label to emit light. The intensity of the emitted light (in ECL units) is correlated with the concentration of toxin in the sample. The minitube assays for the toxin being tested will be purchased from the Joint Program Executive Office for Chemical and Biological Defense (JPEO-CBD, Stafford Virginia) Critical Reagents Program (CRP). Limit of detection and confidence levels can be requested from the CRP.

d. PCR Instrumentation and Assays.

For PCR analysis, the LSTF uses the Applied Biosystems Incorporated (ABI) Prism 7900HT Sequence Detection System (ABI, Carlsbad, California) or equivalent with the ABI TaqMan® probe technology or equivalent. The ABI Prism system is a high-throughput, real-time PCR system that detects and quantifies nucleic acid sequences. Bacterial and viral samples are processed with this instrument using the TaqMan® Detector Absolute Quantification Assay or equivalent

3 July 2013

with the 96-well plate format, IAW DPG SOP WDL-WI-BIO-097⁸ for PCR testing with high throughput. A bead-beating procedure is used to prepare samples of bacterial spores. Ribonucleic acid (RNA)-based viruses [such as Venezuelan equine encephalitis (VEE)] are processed by reverse-transcriptase (RT)-quantitative PCR (RT-qPCR). All procedures for sample preparation for PCR (e.g., sample cleanup, deoxyribonucleic acid (DNA) isolation, and PCR processing) are included in DPG SOP WDL-WI-BIO-094⁹. Resulting data are provided as genome equivalent (GE) values that can be used to calculate an aerosol concentration. For liquid samples that contain less than 5×10^3 GE/mL, the accuracy of the data is unreliable. For samples that contain greater than 5×10^3 GE/mL, the accuracy is generally within 20 percent of the actual assay concentration.

3. REQUIRED TEST CONDITIONS.

3.1 Preparations for Test.

a. **Test Plan.** A test plan will be written to describe how to conduct the test, IAW U.S. Army Test and Evaluation Command (ATEC) guidance, and will be approved by the test center, ATEC, and the customer before the test start.

b. **Criteria.** Appropriate test criteria will be identified from the requirements documents and/or from mission scenarios under evaluation.

c. **Experimental Design.** All SUT configurations of interest should be addressed by the test plan. The TO will determine the order and sequence for testing to ensure a balanced design that will support the analysis and assessment requirements. The test configuration control must be established before the test begins. Changes to the system during testing may impact performance of the SUT.

3.2 Safety.

a. **Safety Assessment Report (SAR).** Before a test is started, the TO will ensure that an adequate SAR or equivalent documentation has been provided by the developer(s) and that it is understood by the testers. The installation safety officer will review the SAR to ensure that it includes information concerning operational limitations and hazards peculiar to the test item. All applicable safety and surety regulations (e.g., Department of the Army (DA) Pamphlet (PAM) 385-69¹⁰, etc.) will be reviewed to ensure compliance of all test procedures. Testing of an individual component or system will not be initiated until the SAR or equivalent documentation is provided and accepted by the installation safety officer.

b. The determination of which BSL is required will be based upon Center for Disease Control (CDC) Biosafety in Microbiological and Biomedical Laboratories (BMBL)¹¹, which establishes the levels of containment based upon the species or strains being tested. Personnel will have adequate safety and hazard training for working in a BSL-2 and BSL-3 laboratory and will have the necessary clearance for handling select agents. All personnel working in the BSL-3 laboratory will be enrolled in the Special Immunization Program (SIP) and will be immunized against select agents as appropriate for these tests.

3 July 2013

c. Safety Procedures. During all test planning, safety concerns will be considered and identified in the SAR. Safety procedures will be established by the TO to ensure test operations are conducted so that test participants and nearby persons, property, and equipment are not exposed to safety or health hazards beyond known operational hazards. Applicable safety regulations, safety directives, and SOPs concerning applicable laboratory operations, facilities, and test items will be followed, and all safety requirements will be met. Any individual protective clothing and equipment appropriate to the procedures, test item, and agent/simulant used will be worn and used IAW the safety procedures established by the installation, TO, safety officer, etc. Any individual observing a safety problem will immediately notify the TO or the safety officer and request resolution of the problem. Any individual observing a hazard that places personnel, equipment, or the environment in immediate jeopardy will take any steps necessary to immediately reduce the hazard. Emergencies will be handled IAW the installation procedures and specific direction given in the SAR by the safety office; safety briefings will be held daily before testing begins. Medical emergencies will be handled by the medics on site (Paragraph 3.2.e).

d. Familiarization. The TO will schedule and ensure that appropriate training for the use of new equipment is provided to personnel by the developer as necessary. The TO, or designated TO, will provide a safety briefing each day and whenever test personnel are changed.

e. Medical Support. The U.S. Army Occupational Health Clinic at DPG and the Ditto Aid Station, West Desert Test Center (WDTC), will provide support for testing. These facilities have SOPs for treating exposure to BWAs. The staff includes emergency medical technicians (EMTs) qualified in advanced life support.

3.3 Environmental Analysis.

When a proposed action may significantly affect the quality of the environment, is highly controversial, or is expected to evoke litigation based on environmental issues, an environmental assessment (EA) will be prepared to determine whether an environmental impact statement (EIS) is required.

3.4 Instrument Calibration.

All instrumentation will be calibrated IAW instruction/operation manuals, SOPs, letters of instruction (LOIs), or other established documentation for proper operation and accurate measurements. Calibration will be current at the beginning of testing, and will be maintained throughout testing to ensure accurate results.

3.5 Chamber/Facility Preparations.

a. Aerosol chambers/facilities will be operated IAW WDL-WI-AER-207¹² for the ASEC and WDL-AER-201¹³ for the CAC. The ABT is placed in operation mode by turning on the power supply to the fan motor to start the airflow. Wind speed is adjusted by altering the position of the air damper immediately upstream of the fan. **NOTE:** The SOP for the ABT has been retired.

3 July 2013

b. All dissemination and referee equipment/instrumentation will be calibrated and plugged into the outlets and tested before trials begin to ensure proper operation.

c. All data collection and monitoring systems, test computers, and SUT(s) will be time-synchronized to Coordinated Universal Time (UTC).

d. All consumables needed for the test will be available before each trial starts.

3.6 Pretest Reviews.

Pretest reviews, which may include the operational readiness inspection (ORI), final command review (FCR), preoperational safety survey (POSS), and/or others as designated by installation management instruction, will be completed, approved, and received from the necessary authorities before record trials commence.

3.7 Data Quality Control (QC).

a. The test planning process will include creation of a data management plan (DMP). All data will be handled IAW the DMP for the SUT.

b. Data acquisition and storage will be accomplished in an automated real-time mode whenever possible. This will minimize transcription errors and data loss and facilitate data reduction and presentation.

c. Data collectors will be used for data acquisition and will be provided with the appropriate training for the instrumentation from which they are collecting data. Data collection sheets will be designed so that no interpretation is required to transcribe data from an instrument display.

d. Pretest readiness inspections and pretrial runs or practice runs will include data transmittal and reduction. Time will be scheduled to resolve data flow issues before the commencement of testing.

e. The test plan will describe sample labeling and chain-of-custody procedures. The appropriate quantity of replicates will be tested, and samples will be collected to permit statistical analysis and evaluation of the data.

f. Data will be reviewed by the TO, project scientist, data manager, and/or test control officer (TCO) to determine if there are any inconsistencies or outliers that need to be resolved.

g. Inconsistencies in the data will be resolved by the TO, data manager, and project scientist before the data are released to the customer. Data clarifications requested by the customer will be addressed between the customer and TO at a predetermined time.

h. The database will be updated periodically by the data manager to address data corrections and clarifications resulting from the resolution of inconsistencies.

i. All data will be retained at the test site in appropriate data storage locations.

j. Test samples and referee samples will be kept in appropriate storage conditions until all data have been reviewed and further analytical processing of the samples is not required. Extended storage times can cause problems with viability; it is important to process any samples in a timely manner. Destruction of test samples should be coordinated by the TO with the customer.

3.8 Operations Security (OPSEC).

a. The security measures and classification for test documentation, data collection, test conduct, and processing of test data will be handled IAW the security classification guide provided by the customer for the test project.

b. An OPSEC planning worksheet will be submitted to the DPG OPSEC officer before the start of the test and signed by the TO and the DPG OPSEC officer. An OPSEC signature sheet will be included in the test plan to show the dates on which the original worksheet was approved with the required signatures.

4. TEST PROCEDURES.

4.1 Purpose.

Conduct test trials in biological aerosol environments to obtain data on the functional performance characteristics of the SUT and/or its subassemblies IAW the test plan.

4.2 Biological Material Production.

The working stock of the biological material will be prepared and quality controlled IAW the handbook of procedures used to produce biological material for testing defense systems⁷. Slurries used for aerosol generation will be prepared from working stocks. The slurries will be quality controlled using the same procedures used for liquid sample analysis⁷.

4.3 Aerosol Chamber Testing.

a. Chamber testing is preferred when particle size distribution and concentration need to be controlled and adjusted to meet test requirements. The SUTs will be tested for performance under the appropriate safety requirements using BWAs and simulants to develop correlations between performance with BWA in chambers and performance with simulants in operational environments.

b. Simulant and BWA aerosol challenges will be performed using the chambers and instrumentation devices described in Paragraph 2. The number, type, and sampling interval of referee instrumentation will depend on the material being aerosolized. Aerosols will be generated from slurries, which are a mixture of the biological challenge material and the appropriate diluent. All particles generated will be in the respirable size range (1 to 10 μm). Aerosol characteristics will include NMAD and mass median aerodynamic diameter (MMAD). The specific environmental conditions, aerosol particle size, aerosol concentration range, and dose concentration range to be used will be described in the test plan.

3 July 2013

c. Simulants of BWAs are nonpathogenic organisms with BWA characteristics that are employed in place of BWAs to minimize the exposure risks to testing personnel. Simulant testing will be conducted by using a representative simulant for each class of similar or related BWA. The best candidates for BWA simulants are materials that are similar in physical and biological properties without the pathogenicity that requires stringent handling procedures. An ALO is defined as an organism having physical properties similar to those of live agents but presenting a reduced level of pathogenicity, usually derived from a vaccine strain or other attenuated strain of an organism (typically a BSL-1 or BSL-2 organism).

d. BWA testing requires BSL-3 facilities, a test fixture chamber, and the associated instrumentation described in Paragraph 2. Testing with aerosolized live/active BWAs or ALOs will be conducted with EMT support at the Ditto Aid Station, WDTC. BWAs and some live ALOs require the presence of two test personnel when any procedure with potential aerosolization is performed. Decontamination procedures for the test fixtures based on the BWA, ALO, or simulant will be followed IAW the approved SOP¹⁴.

e. DPG Biological Material Death Certification Process. Inactivation of biological material will be performed strictly IAW DPG SOPs WDL-BIO-147¹⁵ and/or WDL-LSD-002¹⁴.

(1) When a BWA has been rendered nonviable (killed or inactivated), a DPG death certificate is issued. This document describes the treatment and analysis of the material and states that the specific materials are certified to be nonviable or inactivated. Bacterial viability is determined by plate count. For viruses, viability testing is accomplished with a plaque assay. To assess toxin potency, standard analysis is by mouse assay, whereby the toxoid preparation is injected intraperitoneally into a live mouse. This is performed off site.

(2) The death certificate for the biological material includes the name of the biological material, place and date of sterilization/inactivation, total dosage, if applicable, procedure used, SOP reference, location of record, and place and date of confirmation of death/inactivation. This document is dated and signed by the microbiologist performing the assay or principal investigator (PI), biological safety officer, and the facility responsible officer (RO) of the Life Sciences Division at DPG.

4.4 CAC Preparations and Trial Execution.

a. The CAC will be operated IAW DPG SOP WDL-AER-201¹³.

b. The referee instrumentation/equipment will be operated IAW operator's manuals and/or SOPs applicable to the specific instrument/equipment.

c. All test computers and SUTs will be time-synchronized to UTC. Proper data recording will be ensured by the TCO.

d. All consumables necessary for the operation of the trials will be available for use before the trials begin.

e. The DCC mixing fans will be powered on.

- f. A minimum 5-min background collection time will be recorded using the APS™ before dissemination. This background collection time may be extended depending on the background requirements of the SUT.
- g. Dissemination and sample collection time may vary depending upon the test requirements; however, a steady-state collection is recommended. For example, for a trial that requires a 5-min aerosol generation and a 2-min AGI sample, the AGI will be started 3 minutes after the start of aerosol dissemination to capture the steady-state aerosol concentration. If a 5-min AGI sample is required, the AGI will be started concurrently with the start of aerosol dissemination to capture the average of the aerosol concentration. If a steady-state STA sample collection is required for a 5-min dissemination, a 2-min STA will be started 2 minutes before the end of aerosol generation.
- h. The aerosol challenge will be disseminated IAW the test plan.
- i. The chamber environmental conditions (including temperature and RH) will be recorded IAW the test plan, or as appropriate for the test.
- j. After the end of dissemination, background levels will be sampled and recorded for 5 minutes using the APS™. This background collection time may be extended depending on the background requirements of the SUT.
- k. Test data values will be recorded in the official TO's record log.
- l. After each trial, the recorded APS™ text file will be saved to the appropriate folder.
- m. The CAC end-of-day checklist will be followed:
 - (1) Referee instruments/equipment will be turned off. End-of-day procedures for the SUT will be followed IAW the instructions provided by the customer.
 - (2) The dissemination nozzle and slurry feed line will be rinsed with sterile water.
 - (3) All waste, solid and liquid, from the trial execution will be placed into the integrated autoclave for sterilization.
 - (4) The CAC will be left in operational mode to maintain the differential pressure, which is a safety feature of the chamber.
- n. Test retrograde, i.e., post-test equipment recovery and clean-up procedures, will be performed IAW the CAC SOP¹³ and the decontamination SOP¹⁴.

4.5 ASEC Preparations and Trial Execution.

- a. The ASEC will be operated IAW DPG SOP WDL-WI-AER-207¹².
- b. The Sono-Tek nozzle and stand-alone mixing fans will be set up IAW the operator's manual¹⁶ and the parameters provided for the ASEC (Appendix C), respectively.

3 July 2013

- c. The referee instrumentation/equipment will be operated IAW operator's manuals and/or SOPs applicable to the specific instrument/equipment.
- d. All test computers and SUTs will be time-synchronized to UTC. Proper data recording will be ensured by the test TCO.
- e. All consumables necessary for the operation of the trials will be available for use before the trials begin.
- f. Before dissemination, a background sample will be collected for a minimum of 5 minutes with the APS™. This background collection time may be extended depending on the background requirements of the SUT.
- g. If used, the XMX sampling will be started before the dissemination. Operation will be IAW the operations manual³. Collection times will be specified in the test plan. Background samples will be collected before dissemination and used as checks for any residual contamination of the XMX samples. **NOTE:** See Paragraph 2.2.2.a(5) for limitations of this instrument.
- h. If AGI and/or STA samples are required, the AGIs and/or STA samplers will typically be started at the same time as aerosol dissemination but may vary according to the test requirements.
- i. The stand-alone HEPA filter systems for the chamber will be turned off immediately before the start of aerosol generation.
- j. The aerosol challenge will be disseminated IAW the test plan.
- k. The stand-alone HEPA filters for the chamber will be turned on immediately after the completion of each trial to remove residual particles in the chamber.
- l. The chamber environmental conditions will be recorded as appropriate for the test, including temperature and RH.
- m. After the end of dissemination, a 5-min background collection time will be recorded using the APS™. This background collection time may be extended depending on the background requirements for the SUT.
- n. Test data values will be recorded in the official TO's record log.
- o. After each trial, the recorded APS™ text file will be saved to the appropriate folder.
- p. Referee instruments/equipment will be turned off. End-of-day procedures for the SUT will be followed IAW the instructions provided by the customer.
- q. Test retrograde will be conducted IAW the procedures in DPG SOP WDL-WI-AER-207¹².

4.6 ABT Preparation and Test Execution.

- a. The ABT will be operated IAW the chamber operating instructions.
- b. The referee instrumentation/equipment will be operated IAW operator's manuals and/or procedures applicable to the specific instrument/equipment. Dissemination equipment will be operated IAW SOP DP-0000-D-216¹⁷. The Sono-Tek will be operated IAW the manufacturer's operating instructions¹⁶.
- c. All test computers and SUTs will be time-synchronized to UTC. Proper data recording will be ensured by the TCO.
- d. All consumables necessary for the operation of the trials will be available for use before the trials begin.
- e. With the ABT fan powered off and with the power switch locked in the OFF position, the ABT airflow will be adjusted by manually changing the configuration of the exhaust flow damper. The airflow is monitored by an anemometer. The damper is typically set to an airflow rate of 1 m/sec through the tunnel but can be adjusted depending on the challenge aerosol concentration required. The ABT blower will be powered on by first unlocking the switch and flipping it up to the ON position, and then pressing the black start button on the electrical panel nearest the pre-filter of the bank of HEPA filters at the north end of the tunnel.
- f. The length of the tunnel and the test airflow will affect the time lapse for the arrival of the generated aerosol cloud. The time start for the AGI should coincide with the estimated arrival time of the aerosol cloud. Sample collection must stop when the aerosol cloud has passed. If STA samples are required, the STA samplers must be started before the aerosol cloud arrives and will continue to sample after the aerosol cloud passes.
- g. The ambient environmental conditions of the ABT (including temperature and RH) will be recorded as appropriate for the test.
- h. Test data will be recorded in the official TO's record log.
- i. At the end of the day, referee instruments/equipment will be turned off. End-of-day procedures for the SUT will be followed IAW the instructions provided by the customer. The ABT fans will be turned off IAW the chamber operating instructions.

4.7 Retrograde Operations.

- a. Decontamination. Hydrogen peroxide vapor will be used to decontaminate the SUT while the system is in normal operation mode. Where possible, SUT(s) that contain fluidic systems will be flushed with liquid decontaminants appropriate for the BWA or simulant used. The containment chamber must be verified as decontaminated before the SUT can be removed.
- b. Disposition of Equipment. The test sponsor will provide information for inclusion in the test plan about equipment disposition following testing.

5. DATA REQUIRED.

- a. The data required will vary with the fixture, SUT, and test requirements, but at a minimum will include the following:
- b. Characterization of the aerosol cloud, including concentration, duration, and particle size distribution.
- c. Referee instrumentation used (APST[™], STA sampler, AGI, XMX) and sample collection resolution will be recorded, along with sample volume, background collection time, sample interval, and collection time per sample.
- d. SUT and subassembly identification numbers.
- e. Complete documentation of procedures followed, sequence of events, record of observations, deviations, anomalies, and difficulties encountered.
- f. Photographic documentation of representative test methods used, equipment and instrumentation systems, irregularities, component failure, or other anomalies, as required, on the SUT.
- g. Environmental conditions (temperature and RH).
- h. Continuous recording of critical SUT performance parameters.
- i. Referee instrumentation calibration records.
- j. Certification that all test and referee devices containing clocks are synchronized and recording on UTC.
- k. Analytical data for system performance and referee instrumentation.

6. PRESENTATION OF DATA.

6.1 General.

- a. Presentation of data will be in a format that rapidly conveys whether criteria have been met, partially met, or not met. Graphs, tables, figures, and photographs will be provided as required.
- b. The test results will be presented as a data package and/or in some type of report as required by the statement of work and agreement with the customer.
- c. Data should be provided in the terms and units agreed upon through the data authentication group (DAG) process as referenced in the DMP.
- d. Data will be reported as follows:

- (1) Volume of sample used for assay and volume of buffer, where applicable (e.g., aliquot of slurry, AGI samples, serial dilution, etc.) will be reported as mL.
 - (2) Plate counts from XMX or AGI should be reported as CFU/mL of sample or PFU/mL of sample.
 - (3) PCR assay should be reported as GE/mL and/or GE/L of air, depending on source of sample.
 - (4) ECL assay results should be reported as CFU/mL, ng/mL, and/or ng/L of air [standard curve generated with CRP material], depending on the source of the sample.
 - (5) APSTTM data will be reported as ACPLA if background particles with a distinctive NMAD can be subtracted from the total particle count.
 - (6) STA sampler data will be reported as 4-sec ACPLA values per sector (30 sectors per plate), along with moving averages for 32-sec, 1-min, 2-min, and peak dose (ACPLA).
- e. All data will be reviewed by the test center IAW the DMP before being sent to the customer. Data can be presented as Level 1 or Level 3 data. Level 1 data are in the original form collected during the test. Level 3 data have been checked for accuracy and arranged in a convenient order for handling.

6.2 Data Management.

A single individual will be given overall responsibility for data management. Creation of a DMP will be part of the test planning process. The TO will coordinate the DMP with test center statisticians, test team members, the customer, and ATEC, if applicable. The TO will prepare a flow chart for data generated by referee instrumentation. This flow chart will include chain of custody information, QC and quality assurance (QA) steps, archiving, data reduction, and data safeguarding procedures.

6.3 Types of Data Obtained from the Referee Instrumentation.

a. The XMX data provide biological units (e.g., CFU) per L of air, but not ACPLA. The XMX data do not have the resolution of the STA sampler data because each sample represents the average concentration of at least a 1-min interval, compared with the 4-sec sample resolution of the STA sampler. **NOTE:** There is no commonly used conversion factor between CFU/L of air and ACPLA.

b. The data obtained from the STA sampler are primarily used for quantifying aerosol particles that contain at least one culturable bacterium or bacterial spore. Each particle will, with proper incubation, develop into a colony. The automated colony counter, using software that projects a particle distribution grid onto an agar plate, counts the number of colonies in each of the 30 sectors of the grid. For a STA sampler that completes one revolution in 2 minutes (120 seconds), each sector represents the area swept in 4 seconds, with the first sector corresponding to the interval from 0 to 4 seconds and the last corresponding to the interval from 116 to 120 seconds of the 2-min sample time. The 2-min STA sampler provides greater resolution

3 July 2013

than the 30-min, 60-min, and 120-min samplers. Test requirements will dictate which sampler is appropriate.

c. The data obtained from the AGI samples are primarily used for determining aerosol concentrations of simulant and BWA for vegetative bacteria, bacterial spores, viruses, and toxin. Like the XMX, the AGI data do not have the resolution of the STA sampler data. As with the XMX, there is no universal conversion factor for converting CFU/L of air to ACPLA.

d. The APS™ data provide information about the background aerodynamic particle concentration before and after aerosol dissemination, and the challenge aerosol particle concentration and particle size distribution. The APS™ data do not provide information on particle composition but do provide data on aerodynamic particle size and particle distribution, as well as aerodynamic particle concentration per unit of time.

6.4 Types of Biological Point Detection Systems.

a. Biological point detectors are usually composed of a detector, collector, and identifier. Data requirements for a specific test program may be more or less inclusive than the requirements described in the following paragraphs:

(1) Detector. Detectors are devices that provide presumptive evidence of biological material in an air sample. This function may be combined with that of collectors. Data from detector challenges will be used to calculate probabilities of detection of challenge material (BWA or simulant), aerosol concentration, and aerosol particle size. Unless a test directive specifies otherwise, the following data will be collected: aerosol dissemination start and end times, detector trigger times, number of triggers, the amount of disseminated challenge material per minute or total amount, detector warm-up time and observations on the reliability and maintainability of the detector.

(2) Collector. Collectors are devices that capture and concentrate the aerosol particles for analysis. Collectors may be evaluated with respect to collection efficiency for particles of different compositions, shapes, and sizes, and an efficiency factor may be calculated. The appropriate referee instrumentation for the type of material being aerosolized (see Paragraph 2.2.2, Devices for Characterizing Challenge Aerosols in Test Chambers) will sample concurrently with the collector. The collection efficiency (Y) can be estimated using the following formulas.

Equation 1
$$Y = \frac{U}{F} \times 100\%$$

Where:

Y = the collector efficiency (percent).

U = the aerosol concentration (biological units/L air).

F = the referee aerosol concentration (biological units/L air).

Equation 2

$$U = CV_s/(Rt_s)$$

Where:

U = the aerosol concentration (biological units/L air).

C = the concentration of liquid sample (biological units/mL).

V_s = the collection sample volume (mL).

R = the sampling airflow rate (L air/minutes).

t_s = the sampling duration (minutes).

NOTE: The above calculations are based upon a 100 percent collection efficiency of the referee sample.

(3) Identifier. Identifiers are devices that function to confirm a presumptive result. Their function may rely on antibody-based (immunoassays) or non-antibody-based technologies. Identifier sensitivity is based on the lowest concentration (biological units/L air or biological units/mL of fluid) of the collected sample that produces a true positive identification. Specificity is based on the frequency out of a predetermined number of challenges in which a sample of a specified concentration is correctly identified. Unless a test directive specifies otherwise, the following data will be collected: time to set up, time to warm up, identifier identification time, type of identification (positive, negative, false positive, false negative), and observations on the reliability and maintainability of the identifier.

(This page is intentionally blank.)

APPENDIX A. PARTICLE GENERATION AND DISSEMINATION PROCEDURES WITH SLURRIES OF BIOLOGICAL MATERIAL.

a. This appendix generally addresses how particles of $2.5 \pm 0.5 \mu\text{m}$ aerodynamic diameter are produced and specifically addresses how the number of biological units [colony-forming units (CFU)], plaque forming units (PFU), nanograms (ng)] per particle are determined for each type of material.

b. Aerosol clouds are generated with the Sono-Tek Model 8700-60 ultrasonic spray nozzle system (Sono-Tek Corporation, Milton, New York)¹⁶, or equivalent. Figure A.1 provides a schematic of a Sono-Tek nozzle.

c. A liquid or a liquid suspension of solid particles (slurry) is delivered to the energized nozzle. Many systems can be used to deliver the slurry to the nozzle. An infusion syringe pump is preferred because of its adjustable delivery rate and accuracy over other delivery devices, such as the peristaltic pump. The slurry concentration, the measurement of CFU/mL, and the number of particles that are disseminated in the aerosol (Appendix A, Paragraph j) are interdependent. The slurry should be assayed to determine the CFU/mL, PFU/mL, or ng/mL, which can be used as a guide for calculating the quantity of each of the biological warfare agent (BWA) organisms within the particles generated.

d. The Sono-Tek nozzle generates approximately 6.4×10^7 droplets per mL of liquid. The volume of 1 mL is equivalent to $1.0 \times 10^{12} \mu\text{m}^3$. When initially disseminated, each droplet contains both solid (BWA and salts) and liquid [water or phosphate-buffered saline (PBS)] components. The water evaporates almost instantly, allowing the solids to coalesce. These particles are then collected using different referee systems and analyzed by various methods.

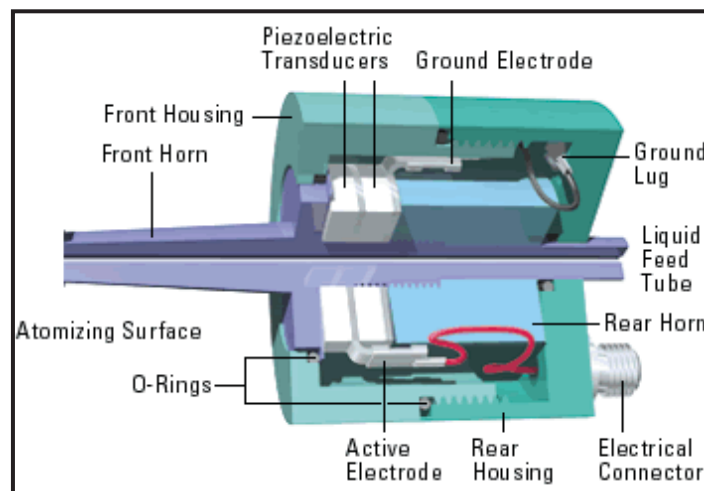

Figure A.10. Sono-Tek ultrasonic spray nozzle system model 8700-60.

APPENDIX A. PARTICLE GENERATION AND DISSEMINATION PROCEDURES
WITH SLURRIES OF BIOLOGICAL MATERIAL.

e. For the purpose of this appendix, droplets are defined as the particles generated by the Sono-Tek nozzle from the slurry. For simplicity purposes, it is assumed that dried-down particles generated from the slurry are perfectly spherical. Two common packing types will provide the optimum spherical packing density. Regardless of the type used, the maximum theoretical particle occupancy of any given space is 74 percent, which leaves a void space of approximately 26 percent. In most real-world cases, however, the occupancy is lower. When spheres are randomly added to a container (for example, a tester fills a container with biological material containing droplets of 31- μm diameter) and then the spheres are compressed (the liquid is evaporated from the particles), the particles form what is known as an irregular or jammed packing configuration and can be compressed no further. This irregular packing will generally leave a void space of 36 percent, generating a value that is close to eight spores per particle in the case of *Bacillus atrophaeus* (BG). This value can then be used with agent containing particles/liter air (ACPLA), as determined with the Aerodynamic Particle Sizer[®] (APSTM, TSI Incorporated, Shoreview, Minnesota), to correlate ACPLA to total agent units per 2.5 \pm 0.5- μm particle for each of the biological materials used. The biological units per particle for any biological material are directly dependent on the slurry concentration that can vary with each production batch.

f. To achieve a targeted dry particle size, the slurry must be concentrated enough to deliver the minimum solids. For example, if the target diameter size is 2.5 μm and the first dilution of the biological material stock (referred to as Slurry 1 for this example) produces 6- μm particles, as measured by the APSTM, then Slurry 1 must be further diluted until the desired size is achieved. This procedure, if carried out incrementally, will allow the generation of the targeted dried-down particle size. If the initial dissemination results in a particle smaller than 2.5 μm , then a more concentrated slurry (higher solid content) is required.

g. An example of slurry preparation using biological material is the BG slurry. It is prepared by suspending a measured quantity of dry BG in a measured amount of distilled water. The resulting dried-down particle size depends mainly on the amount (volume fraction) of solids in the droplet, which is the same as the fraction of solid in the slurry. The wet particle diameter, dried-down particle diameter, and the fraction of solid in the slurry are related by the formula in Equation A.1:

Equation A.1
$$F_v = \left(\frac{d_d}{d_w}\right)^3$$

Where:

d_d = the diameter of the dried-down droplet (solid).

d_w = the diameter of the wet droplet.

F_v = the volume fraction of solid material in the slurry.

h. Example for Equation A.1.

APPENDIX A. PARTICLE GENERATION AND DISSEMINATION PROCEDURES
WITH SLURRIES OF BIOLOGICAL MATERIAL.

(1) The d_w for the nozzles used is 31 μm , and the desired d_d is 2.5 μm . Substituting the values 31 μm and 2.5 μm into the variables in Equation A.1 yields Equation A.2.

$$\text{Equation A.2} \quad F_v = \left(\frac{2.5}{31}\right)^3 = 0.000524$$

Where:

F_v is the volume fraction of solid material in the slurry.

(2) Once the volume fraction has been calculated, the mass of dry material can be calculated with Equation A.3.

$$\text{Equation A.3} \quad m = VF_v\rho$$

Where:

m = the mass of dry material in grams.

V = the volume of the slurry in mL.

F_v = the volume fraction of solid material in the slurry.

ρ = the density of the dry material in g/mL.

(3) For example, assuming the density for BG solid is 1.0 g/cm³, the mass of dry BG required to prepare 100 mL of slurry can be found by applying Equation A.3 (see Equation A.4).

$$\text{Equation A.4} \quad 100 \times 0.000524 \times 1.0 = 0.0524 \text{ g}$$

i. The value obtained from Equation A.3 is only the theoretical value and can be used as a starting point. In reality, the mass of dry BG required will be higher than this value because there will be some settling of solids in the delivery system, even with agitation. Therefore, the actual quantity of solids required to achieve the final dried-down particle size must be adjusted accordingly. Settling of solids in the slurry is a function of the biological material used. The settling factor for the biological material of interest can be determined experimentally.

j. Particle parameters can be individually calculated based on the above information using Equations A.5 through A.7. The biological units for slurry concentration vary depending on the type of data collected.

APPENDIX A. PARTICLE GENERATION AND DISSEMINATION PROCEDURES
WITH SLURRIES OF BIOLOGICAL MATERIAL.

Equation A.5
$$r_b = r_i c_s$$

Where:

r_b = the biological unit output rate in CFU/min, PFU/min, or ng/min.

r_i = the slurry input rate in mL/min.

c_s = the slurry concentration in biological units.

Equation A.6
$$r_d = r_i y$$

Where:

r_i = the slurry input rate in mL/min.

y = the number of droplets produced per mL of slurry.

r_d = the droplet production rate in droplets/min.

k. Equation A.7 can be used to calculate values for CFU/droplet, PFU/droplet, and ng/droplet. With the total biological units in the sample known and the biological units per particle determined, the ACPLA of the aerosol cloud can be calculated for comparison with the APSTTM data (Appendix B). The calculation can also be used to convert ACPLA to CFU, PFU, or ng/L of air. **NOTE:** The biological units per particle for any biological material are directly dependent on the slurry concentration that can vary with each production batch.

Equation A.7
$$\rho_b = \frac{r_b}{r_d}$$

Where:

ρ_b = the biological units per droplet.

r_b = the biological unit output rate in CFU/min, PFU/min or ng/min (Equation A.5).

r_d = the droplet generation rate in droplets/min (Equation A.6).

APPENDIX B. REFEREE INSTRUMENTATION DATA REDUCTION
AND CONVERSION.

TABLE LIST

<u>TABLE</u>	<u>PAGE</u>
B.1 BIOLOGICAL UNITS OF MEASURE.	B-2
B.2 SAMPLE SECTOR COUNT DATA AND AGENT-CONTAINING PARTICLES PER LITER OF AIR (ACPLA) CALCULATION DATA FOR A 2-MIN SLIT-TO-AGAR (STA) SAMPLER WITH A SAMPLING FLOW RATE OF 28.3 L/MIN.	B-6
B.3 EXAMPLE CALCULATIONS TO OBTAIN SINGLE SLIT-TO-AGAR (STA) SAMPLER DATA 32-SEC SIMPLE MOVING AVERAGES (SMAS).	B-8
B.4 EXAMPLE CALCULATIONS TO OBTAIN SINGLE SLIT-TO-AGAR (STA) SAMPLER DATA 1-MIN SIMPLE MOVING AVERAGES (SMAS).	B-10
B.5 EXAMPLE CALCULATIONS TO OBTAIN SINGLE SLIT-TO-AGAR (STA) SAMPLER DATA 2-MIN SIMPLE MOVING AVERAGES (SMAS).	B-12
B.6 EXAMPLE OF AVERAGE CALCULATION RESULTS FOR THREE 2- MIN SLIT-TO-AGAR (STA) SAMPLERS.	B-14
B.7 EXAMPLE OF CALCULATION OF COLONY-FORMING UNITS (CFU) PER LITER OF AIR (CFU/L AIR) FROM PLATE DATA.	B-21
B.8 EXAMPLE OF CALCULATION OF PLAQUE-FORMING UNITS (PFU) PER LITER OF AIR (PFU/L AIR) FROM PLAQUE DATA.	B-22

FIGURE LIST

<u>FIGURE</u>	<u>PAGE</u>
B.1 Average particle distribution for a 2.5- μ m number mean aerodynamic diameter (NMAD) aerosol.	B-27
B.2 Process of subtracting the background particle distribution from collected trial data.	B-33

APPENDIX B. REFEREE INSTRUMENTATION DATA REDUCTION
AND CONVERSION.

1. UNITS OF MEASURE.

There are several units of measure used to express the concentration of biological material in liquid and aerosols for challenging biological detectors. These units are dependent on the class of material used to produce the slurries and aerosols. This test operations procedure (TOP) addresses four classes of biological materials: bacterial spore, vegetative bacteria, viruses, and toxins. To avoid confusion, test data should be expressed in the same units throughout the test program for each class of material. Biological units of measure used in this TOP are noted in Table B.1 and described in the following paragraphs.

a. Colony-Forming Units (CFU) Per Unit Volume. The CFU per unit volume is used to express the concentration of bacterial spores and vegetative bacterial materials derived from electrochemiluminescence (ECL) assay or plate counts. The unit of measure is expressed in CFU/mL for liquid slurries and CFU/L of air for aerosols.

b. Plaque-Forming Units (PFU) Per Unit Volume. The PFU per unit volume is used to express concentration results derived from plaque assay for viral materials derived from plaque analysis. The unit of measure is expressed in PFU/mL for liquid and PFU/L of air for aerosols.

c. Nanograms (ng) Per Unit Volume. The ng per unit volume is used to quantitate concentrations for toxin materials. The unit of measure is expressed in ng/mL for liquid slurries and ng/L of air for aerosols.

d. Genome Equivalents (GE) Per Unit Volume. The GE per unit volume is used to express concentration for bacterial spores, vegetative bacteria, and viruses derived from polymerase chain reaction (PCR) analysis. The unit of measure is expressed in GE/mL for liquid and GE/L of air for aerosols.

Table B.1. BIOLOGICAL UNITS OF MEASURE.

Biological Material Class	Unit of Measurement	
	Liquid	Aerosol
Bacterial spore	Genome equivalents (GE)/mL	GE/L air
	Colony-forming units (CFU)/mL	CFU/L air and agent-containing particles/L of air (ACPLA)
Vegetative bacteria	GE/mL	GE/L air
	CFU/mL	CFU/L air and ACPLA
Viruses	GE/mL	GE/L air
	Plaque-forming units (PFU)/mL	PFU/L air and ACPLA
Toxins	Nanograms (ng)/mL	ACPLA and ng/L air

APPENDIX B. REFEREE INSTRUMENTATION DATA REDUCTION AND CONVERSION.

e. Agent Containing Particles/L of Air (ACPLA). ACPLA is used to express the concentration of aerosol particles per L of air. ACPLA can be expressed as an average value calculated over a time interval or as an instantaneous value.

f. Aerosol Particles/L of Air Without Background Particles (Po/L). Po/L is used to express an estimate of the concentration of aerosol particles/L of air without background particles. Po/L can be expressed as an average value calculated over a time interval or as an instantaneous value.

g. Number Median Aerodynamic Diameter (NMAD). The NMAD, which is calculated based on the particle distribution as measured by the Aerodynamic Particle Sizer[®] (APS[™], TSI Incorporated, Shoreview, Minnesota), provides the median aerodynamic diameter in μm of the distribution of airborne particles of a particular size bin as sampled by the APS[™]. Half of the number of particles in the size bin have aerodynamic diameters less than or equal to the stated NMAD bin size, and half of the number of particles have aerodynamic diameters greater than the stated NMAD bin size.

h. Mass Median Aerodynamic Diameter (MMAD). The MMAD, which is calculated based on the particle distribution as measured by the APS[™], provides the median aerodynamic diameter in μm of the distribution of airborne particle mass of a particular size bin as sampled by the APS[™]. Half of the mass of the particles in the size bin have aerodynamic diameters less than or equal to the stated MMAD bin size, and half of the mass of all the particles have aerodynamic diameters greater than the stated MMAD bin size.

2. CALCULATION OF ACPLA FROM SLIT-TO-AGAR (STA) SAMPLER DATA

During aerosol sampling, an agar plate is rotated by the STA turn table at a constant speed for one complete revolution. The aerosol particles carried by the STA-sampled air impact the agar plate. The agar plate is then incubated to allow the impacted bacteria to grow. Following incubation, the agar plate is divided into 30 sectors of equal area, and the number of colonies in each sector are counted and recorded. For a 2-min STA sampling session, each of the 30 pie-shaped sectors of the agar plate represents 4 seconds of STA sampling.

a. The ACPLA for each agar sector is calculated by dividing the number of colony counts per sector by the volume of air sampled per STA sampler sector. Table B.2 contains a summary of the calculation for a single 2-min STA sampling session. Equations B.1 and B.2 show the steps to calculate ACPLA from the STA sampler data:

APPENDIX B. REFEREE INSTRUMENTATION DATA REDUCTION
AND CONVERSION.

Equation B.1
$$V_{STA} = \frac{r_s t_s}{S}$$

Where:

V_{STA} = the sample volume per sector of collection media (L/sector).

r_s = the STA sampler airflow in L/min.

t_s = the sampling time in min.

S = number of sectors on the collection media.

Equation B.2
$$ACPLA = \frac{\kappa}{V_{STA}}$$

Where:

ACPLA = the agent containing particles per liter of air.

κ = the particle count in a sector.

V_{STA} = the sample volume per sector in L/sector.

b. Given the STA sampler airflow rate of 28.3 L/min, with 2 minutes on 30 sectors, and substituting these values into Equation B.1, the sample volume is 1.89 L/sector. For the current methodology used in Whole-System Live Agent Test (WSLAT) the ACPLA can then be calculated with Equation B.3.

Equation B.3
$$ACPLA = \frac{\kappa}{1.89}$$

Where:

ACPLA = the agent containing particles per liter of air.

κ = the particle count per sector.

c. From the calculated ACPLA, three simple moving averages (SMA) can be obtained: a 32-sec moving average (over eight sectors of agar) or $SMA_{(8)}$, a 1-min moving average or $SMA_{(15)}$ (over 15 sectors of agar), and a 2-min moving average or $SMA_{(30)}$ (over 30 sectors of agar) (Equation B.4). Each of these three time-interval SMAs can be used to obtain smoothed plots of aerosol concentration versus time and estimates of maximum concentration. $SMA_{(8)}$, $SMA_{(15)}$, and $SMA_{(30)}$ are calculated from Equation B.4 with k set equal to 8, 15, and 30, respectively. The SMA is not defined early in the time series (Tables B.2, B.3, and B.4).

APPENDIX B. REFEREE INSTRUMENTATION DATA REDUCTION
AND CONVERSION.*Equation B.4*

$$\overline{x_{l,k}} = \frac{1}{k} \sum_{i=k+1}^i x_l$$

Where:

$\overline{x_{l,k}}$ = the simple moving average at the i^{th} data point over k sectors (typically 8, 15, or 30 sectors for 32-sec, 1-min and 2-min SMAs, respectively).

x_l = a data point used in the SMA.

k = the number of sectors in the SMA.

i = index of the current data point.

l = the index of a data point used in the SMA.

APPENDIX B. REFEREE INSTRUMENTATION DATA REDUCTION
AND CONVERSION.

Table B.2. SAMPLE SECTOR COUNT DATA AND AGENT-CONTAINING PARTICLES
PER LITER OF AIR (ACPLA) CALCULATION DATA FOR A 2-MIN SLIT-
TO-AGAR (STA) SAMPLER WITH A SAMPLING FLOW RATE OF
28.3 L/MIN.

Sector Number	Time	Particle Count/Sector	ACPLA
1	1703:00	108	57.14
2	1703:04	152	80.42
3	1703:08	141	74.60
4	1703:12	136	71.96
5	1703:16	123	65.08
6	1703:20	119	62.96
7	1703:24	130	68.78
8	1703:28	163	86.24
9	1703:32	147	77.78
10	1703:36	144	76.19
11	1703:40	156	82.54
12	1703:44	136	71.96
13	1703:48	161	85.19
14	1703:52	157	83.07
15	1703:56	151	79.89
16	1704:00	137	72.49
17	1704:04	121	64.02
18	1704:08	127	67.20
19	1704:12	137	72.49
20	1704:16	115	60.85
21	1704:20	137	72.49
22	1704:24	110	58.20
23	1704:28	102	53.97
24	1704:32	112	59.26
25	1704:36	115	60.85
26	1704:40	117	61.90
27	1704:44	128	67.72
28	1704:48	91	48.15
29	1704:52	108	57.14
30	1704:56	111	58.73

APPENDIX B. REFEREE INSTRUMENTATION DATA REDUCTION
AND CONVERSION.

d. For multiple STA samplers, the 32-sec SMA, 1-min SMA, 2-min SMA, and corresponding peaks are calculated in a similar fashion (Equation B.5). Table B.6 provides an example of these calculations for three, 2-min STA samplers.

Equation B.5
$$X_k = \max_i \overline{x_{i,k}}$$

Where:

X_k = the maximum of the moving average over k data points (8, 15 or 30 data points).

$\overline{x_{i,k}}$ = the simple moving average at the i^{th} data point over k sectors (typically 8, 15, or 30 sectors for 32-sec and 1- and 2-min SMAs) from Equation B.4.

k = the number of data points in the moving average.

i = the index of a data point used in the moving average.

APPENDIX B. REFEREE INSTRUMENTATION DATA REDUCTION
AND CONVERSION.

Table B.3. EXAMPLE CALCULATIONS TO OBTAIN SINGLE SLIT-TO-AGAR (STA) SAMPLER DATA 32-SEC SIMPLE MOVING AVERAGES (SMAS).

Sample Number	Time	ACPLA ^a	8-Sector SMA [SMA ₍₈₎] Calculation	32-Sec Average (ACPLA)
1	1703:00	57.14	Not applicable (NA)	NA
2	1703:04	80.42	NA	NA
3	1703:08	74.60	NA	NA
4	1703:12	71.96	NA	NA
5	1703:16	65.08	NA	NA
6	1703:20	62.96	NA	NA
7	1703:24	68.78	NA	NA
8	1703:28	86.24	$(57.14 + 80.42 + 74.60 + 71.96 + 65.08 + 62.96 + 68.78 + 86.24)/8 =$	70.90
9	1703:32	77.78	$(80.42 + 74.60 + 71.96 + 65.08 + 62.96 + 68.78 + 86.24 + 77.78)/8 =$	73.48
10	1703:36	76.19	$(74.60 + 71.96 + 65.08 + 62.96 + 68.78 + 86.24 + 77.78 + 76.19)/8 =$	72.95
11	1703:40	82.54	$(71.96 + 65.08 + 62.96 + 68.78 + 86.24 + 77.78 + 76.19 + 82.54)/8 =$	73.94
12	1703:44	71.96	$(65.08 + 62.96 + 68.78 + 86.24 + 77.78 + 76.19 + 82.54 + 71.96)/8 =$	73.94
13	1703:48	85.19	$(62.96 + 68.78 + 86.24 + 77.78 + 76.19 + 82.54 + 71.96 + 85.19)/8 =$	76.46
14	1703:52	83.07	$(68.78 + 86.24 + 77.78 + 76.19 + 82.54 + 71.96 + 85.19 + 83.07)/8 =$	78.97
15	1703:56	79.89	$(86.24 + 77.78 + 76.19 + 82.54 + 71.96 + 85.19 + 83.07 + 79.89)/8 =$	80.36
16	1704:00	72.49	$(77.78 + 76.19 + 82.54 + 71.96 + 85.19 + 83.07 + 79.89 + 72.49)/8 =$	78.64
17	1704:04	64.02	$(76.19 + 82.54 + 71.96 + 85.19 + 83.07 + 79.89 + 72.49 + 64.02)/8 =$	76.92
18	1704:08	67.20	$(82.54 + 71.96 + 85.19 + 83.07 + 79.89 + 72.49 + 64.02 + 67.20)/8 =$	75.79
19	1704:12	72.49	$(71.96 + 85.19 + 83.07 + 79.89 + 72.49 + 64.02 + 67.20 + 72.49)/8 =$	74.54
20	1704:16	60.85	$(85.19 + 83.07 + 79.89 + 72.49 + 64.02 + 67.20 + 72.49 + 60.85)/8 =$	73.15
21	1704:20	72.49	$(83.07 + 79.89 + 72.49 + 64.02 + 67.20 + 72.49 + 60.85 + 72.49)/8 =$	71.56
22	1704:24	58.20	$(79.89 + 72.49 + 64.02 + 67.20 + 72.49 + 60.85 + 72.49 + 58.20)/8 =$	68.45

APPENDIX B. REFEREE INSTRUMENTATION DATA REDUCTION
AND CONVERSION

Table B.3. EXAMPLE CALCULATIONS TO OBTAIN SINGLE SLIT-TO-AGAR (STA) SAMPLER DATA
32-SEC SIMPLE MOVING AVERAGES (SMAS) (CONT'D).

Sample Number	Time	ACPLA ^a	8-Sector SMA [SMA ₍₈₎] Calculation	32-Sec Average (ACPLA)
23	1704:28	53.97	$(72.49 + 64.02 + 67.20 + 72.49 + 60.85 + 72.49 + 58.20 + 53.97)/8 =$	65.21
24	1704:32	59.26	$(64.02 + 67.20 + 72.49 + 60.85 + 72.49 + 58.20 + 53.97 + 59.26)/8 =$	63.56
25	1704:36	60.85	$(67.20 + 72.49 + 60.85 + 72.49 + 58.20 + 53.97 + 59.26 + 60.85)/8 =$	63.16
26	1704:40	61.90	$(72.49 + 60.85 + 72.49 + 58.20 + 53.97 + 59.26 + 60.85 + 61.90)/8 =$	62.50
27	1704:44	67.72	$(60.85 + 72.49 + 58.20 + 53.97 + 59.26 + 60.85 + 61.90 + 67.72)/8 =$	61.90
28	1704:48	48.15	$(72.49 + 58.20 + 53.97 + 59.26 + 60.85 + 61.90 + 67.72 + 48.15)/8 =$	60.32
29	1704:52	57.14	$(58.20 + 53.97 + 59.26 + 60.85 + 61.90 + 67.72 + 48.15 + 57.14)/8 =$	58.40
30	1704:56	58.73	$(53.97 + 59.26 + 60.85 + 61.90 + 67.72 + 48.15 + 57.14 + 58.73)/8 =$	58.47

^aAgent-containing particles per liter of air.

NOTE: Notice the first average value starts at sample number 8.

APPENDIX B. REFEREE INSTRUMENTATION DATA REDUCTION
AND CONVERSION.

Table B.4. EXAMPLE CALCULATIONS TO OBTAIN SINGLE SLIT-TO-AGAR (STA) SAMPLER DATA
1-MIN SIMPLE MOVING AVERAGES (SMAS).

Sample Number	Time	ACPLA ^a	15-Sector [SMA ₍₁₅₎] Calculation	1-Min Average (ACPLA)
1	1703:00	57.14	Not applicable (NA)	NA
2	1703:04	80.42	NA	NA
3	1703:08	74.60	NA	NA
4	1703:12	71.96	NA	NA
5	1703:16	65.08	NA	NA
6	1703:20	62.96	NA	NA
7	1703:24	68.78	NA	NA
8	1703:28	86.24	NA	NA
9	1703:32	77.78	NA	NA
10	1703:36	76.19	NA	NA
11	1703:40	82.54	NA	NA
12	1703:44	71.96	NA	NA
13	1703:48	85.19	NA	NA
14	1703:52	83.07	NA	NA
15	1703:56	79.89	(57.14 + 80.42 + 74.60 + ... + 79.89)/15	74.92
16	1704:00	72.49	(80.42 + 74.60 + 71.96 + ... + 72.49)/15	75.94
17	1704:04	64.02	(74.60 + 71.96 + 65.08 + ... + 64.02)/15	74.85
18	1704:08	67.20	(71.96 + 65.08 + 62.96 + ... + 67.20)/15	74.36
19	1704:12	72.49	(65.08 + 62.96 + 68.78 + ... + 72.49)/15	74.39
20	1704:16	60.85	(62.96 + 68.78 + 86.24 + ... + 60.85)/15	74.11

APPENDIX B. REFEREE INSTRUMENTATION DATA REDUCTION
AND CONVERSION

Table B.4. EXAMPLE CALCULATIONS TO OBTAIN SINGLE SLIT-TO-AGAR (STA) SAMPLER DATA
1-MIN SIMPLE MOVING AVERAGES (SMAS) (CONT'D).

Sample Number	Time	ACPLA ^a	15-Sector SMA [SMA ₍₁₅₎] Calculation	1-Min Average (ACPLA)
21	1704:20	72.49	$(68.78 + 86.24 + 77.78 + \dots + 72.49)/15$	74.74
22	1704:24	58.20	$(86.24 + 77.78 + 76.19 + \dots + 58.20)/15$	74.04
23	1704:28	53.97	$(77.78 + 76.19 + 82.54 + \dots + 53.97)/15$	71.89
24	1704:32	59.26	$(76.19 + 82.54 + 71.96 + \dots + 59.26)/15$	70.65
25	1704:36	60.85	$(82.54 + 71.96 + 85.19 + \dots + 60.85)/15 =$	69.63
26	1704:40	61.90	$(71.96 + 85.19 + 83.07 + \dots + 61.90)/15 =$	68.25
27	1704:44	67.72	$(85.19 + 83.07 + 79.89 + \dots + 67.72)/15 =$	67.97
28	1704:48	48.15	$(83.07 + 79.89 + 72.49 + \dots + 48.15)/15 =$	65.50
29	1704:52	57.14	$(79.89 + 72.49 + 64.02 + \dots + 57.14)/15 =$	63.77
30	1704:56	58.73	$(72.49 + 64.02 + 67.20 + \dots + 58.73)/15 =$	62.36

^a Agent-containing particles per liter of air.

NOTE: Notice the first average value starts at sample number 15.

APPENDIX B. REFEREE INSTRUMENTATION DATA REDUCTION
 AND CONVERSION.

Table B.5. EXAMPLE CALCULATIONS TO OBTAIN SINGLE SLIT-TO-AGAR (STA) SAMPLER DATA 2-MIN SIMPLE MOVING AVERAGES (SMAS).

Sample Number	Time	ACPLA ^a	30-Sector SMA [SMA ₍₃₀₎] Calculation	2-Min Average (ACPLA)
1	1703:00	57.14	Not applicable (NA)	NA
2	1703:04	80.42	NA	NA
3	1703:08	74.60	NA	NA
4	1703:12	71.96	NA	NA
5	1703:16	65.08	NA	NA
6	1703:20	62.96	NA	NA
7	1703:24	68.78	NA	NA
8	1703:28	86.24	NA	NA
9	1703:32	77.78	NA	NA
10	1703:36	76.19	NA	NA
11	1703:40	82.54	NA	NA
12	1703:44	71.96	NA	NA
13	1703:48	85.19	NA	NA
14	1703:52	83.07	NA	NA
15	1703:56	79.89	NA	NA
16	1704:00	72.49	NA	NA
17	1704:04	64.02	NA	NA
18	1704:08	67.20	NA	NA
19	1704:12	72.49	NA	NA
20	1704:16	60.85	NA	NA
21	1704:20	72.49	NA	NA

APPENDIX B. REFEREE INSTRUMENTATION DATA REDUCTION
AND CONVERSION

Table B.5. EXAMPLE CALCULATIONS TO OBTAIN SINGLE SLIT-TO-AGAR (STA) SAMPLER DATA 2-MIN SIMPLE MOVING AVERAGES (SMAS) (CONT'D).

Sample Number	Time	ACPLA ^a	30-Sector SMA [SMA ₍₃₀₎] Calculation	2-Min Average (ACPLA)
22	1704:24	58.20	NA	NA
23	1704:28	53.97	NA	NA
24	1704:32	59.26	NA	NA
25	1704:36	60.85	NA	NA
26	1704:40	61.90	NA	NA
27	1704:44	67.72	NA	NA
28	1704:48	48.15	NA	NA
29	1704:52	57.14	NA	NA
30	1704:56	58.73	(57.14 + 80.42 + 74.60 + ... + 58.73)/30 =	68.64

^a Agent-containing particles per liter of air.

NOTE: Notice the first average value starts at sample number 30.

APPENDIX B. REFEREE INSTRUMENTATION DATA REDUCTION
AND CONVERSION.

Table B.6. EXAMPLE OF AVERAGE CALCULATION RESULTS FOR THREE 2-MIN SLIT-TO-AGAR (STA) SAMPLERS.

Sector Number	Colony Count (CC)/Sec	Time	ACPLA ^a	32-Sec Average (ACPLA)	1-Min Average (ACPLA)	2-Min Average (ACPLA)
1-1	3	1520:00	1.59	Not applicable (NA)	NA	NA
1-2	0	1520:04	0.00	NA	NA	NA
1-3	24	1520:08	12.70	NA	NA	NA
1-4	13	1520:12	6.88	NA	NA	NA
1-5	9	1520:16	4.76	NA	NA	NA
1-6	13	1520:20	6.88	NA	NA	NA
1-7	15	1520:24	7.94	NA	NA	NA
1-8	13	1520:28	6.88	6	NA	NA
1-9	26	1520:32	13.76	7	NA	NA
1-10	25	1520:36	13.23	9	NA	NA
1-11	28	1520:40	14.81	9	NA	NA
1-12	28	1520:44	14.81	10	NA	NA
1-13	30	1520:48	15.87	12	NA	NA
1-14	37	1520:52	19.58	13	NA	NA
1-15	33	1520:56	17.46	15	10	NA
1-16	44	1521:00	23.28	17	12	NA
1-17	42	1521:04	22.22	18	13	NA
1-18	42	1521:08	22.22	19	14	NA
1-19	37	1521:12	19.58	19	15	NA
1-20	40	1521:16	21.16	20	16	NA
1-21	32	1521:20	16.93	20	17	NA

APPENDIX B. REFEREE INSTRUMENTATION DATA REDUCTION
AND CONVERSION.

Table B.6. EXAMPLE OF AVERAGE CALCULATION RESULTS FOR THREE 2-MIN SLIT-TO-AGAR (STA) SAMPLERS
(CONT'D).

Sector Number	Colony Count (CC)/Sec	Time	ACPLA ^a	32-Sec Average (ACPLA)	1-Min Average (ACPLA)	2-Min Average (ACPLA)
1-22	51	1521:24	26.98	21	18	NA
1-23	33	1521:28	17.46	21	19	NA
1-24	50	1521:32	26.46	22	19	NA
1-25	47	1521:36	24.87	22	20	NA
1-26	33	1521:40	17.46	21	20	NA
1-27	38	1521:44	20.11	21	21	NA
1-28	41	1521:48	21.69	21	21	NA
1-29	48	1521:52	25.40	23	22	NA
1-30	48	1521:56	25.40	22	22	16
2-1	48	1522:00	25.40	23	22	17
2-2	57	1522:04	30.16	24	23	18
2-3	50	1522:08	26.46	24	23	19
2-4	34	1522:12	17.99	24	23	19
2-5	34	1522:16	17.99	24	23	19
2-6	41	1522:20	21.69	24	23	20
2-7	41	1522:24	21.69	23	23	20
2-8	43	1522:28	22.75	23	23	21
2-9	41	1522:32	21.69	23	23	21
2-10	46	1522:36	24.34	22	23	21

APPENDIX B. REFEREE INSTRUMENTATION DATA REDUCTION
AND CONVERSION.

Table B.6. EXAMPLE OF AVERAGE CALCULATION RESULTS FOR THREE 2-MIN SLIT-TO-AGAR (STA) SAMPLERS
(CONT'D).

Sector Number	Colony Count (CC)/Sec	Time	ACPLA ^a	32-Sec Average (ACPLA)	1-Min Average (ACPLA)	2-Min Average (ACPLA)
2-11	46	1522:40	24.34	22	23	22
2-12	45	1522:44	23.81	22	23	22
2-13	50	1522:48	26.46	23	24	22
2-14	43	1522:52	22.75	23	24	23
2-15	40	1522:56	21.16	23	23	23
2-16	48	1523:00	25.40	24	23	23
2-17	34	1523:04	17.99	23	22	23
2-18	41	1523:08	21.69	23	22	23
2-19	46	1523:12	24.34	23	23	23
2-20	41	1523:16	21.69	23	23	23
2-21	41	1523:20	21.69	22	23	23
2-22	49	1523:24	25.93	22	23	23
2-23	30	1523:28	15.87	22	23	23
2-24	54	1523:32	28.57	22	23	23
2-25	44	1523:36	23.28	23	23	23
2-26	31	1523:40	16.40	22	22	23
2-27	36	1523:44	19.05	22	22	23
2-28	35	1523:48	18.52	21	22	23

APPENDIX B. REFEREE INSTRUMENTATION DATA REDUCTION
AND CONVERSION.

Table B.6. EXAMPLE OF AVERAGE CALCULATION RESULTS FOR THREE 2-MIN SLIT-TO-AGAR (STA) SAMPLERS (CONT'D).

Sector Number	Colony Count (CC)/Sec	Time	ACPLA ^a	32-Sec Average (ACPLA)	1-Min Average (ACPLA)	2-Min Average (ACPLA)
2-29	43	1523:52	22.75	21	22	23
2-30	39	1523:56	20.63	21	22	22
3-1	18	1524:00	9.52	20	21	22
3-2	38	1524:04	20.11	19	21	22
3-3	29	1524:08	15.34	18	20	21
3-4	33	1524:12	17.46	18	20	21
3-5	31	1524:16	16.40	18	19	21
3-6	27	1524:20	14.29	17	19	21
3-7	31	1524:24	16.40	16	18	21
3-8	35	1524:28	18.52	16	18	21
3-9	25	1524:32	13.23	16	17	20
3-10	39	1524:36	20.63	17	17	20
3-11	39	1524:40	20.63	17	18	20
3-12	32	1524:44	16.93	17	17	20
3-13	34	1524:48	17.99	17	17	20
3-14	33	1524:52	17.46	18	17	19
3-15	32	1524:56	16.93	18	17	19
3-16	31	1525:00	16.40	18	17	19
3-17	33	1525:04	17.46	18	17	19

APPENDIX B. REFEREE INSTRUMENTATION DATA REDUCTION
AND CONVERSION.

Table B.6. EXAMPLE OF AVERAGE CALCULATION RESULTS FOR THREE 2-MIN SLIT-TO-AGAR (STA) SAMPLERS
(CONT'D).

Sector Number	Colony Count (CC)/Sec	Time	ACPLA ^a	32-Sec Average (ACPLA)	1-Min Average (ACPLA)	2-Min Average (ACPLA)
3-18	25	1525:08	13.23	17	17	19
3-19	13	1525:12	6.88	15	16	18
3-20	29	1525:16	15.34	15	16	18
3-21	30	1525:20	15.87	15	16	18
3-22	40	1525:24	21.16	15	17	17
3-23	30	1525:28	15.87	15	16	17
3-24	21	1525:32	11.11	15	16	17
3-25	29	1525:36	15.34	14	16	17
3-26	22	1525:40	11.64	14	15	16
3-27	20	1525:44	10.58	15	15	16
3-28	17	1525:48	8.99	14	14	16
3-29	20	1525:52	10.58	13	14	15
3-30	23	1525:56	12.17	12	14	15

^aAgent-containing particles per liter of air.

APPENDIX B. REFEREE INSTRUMENTATION DATA REDUCTION
AND CONVERSION.

3. CALCULATION OF CFU/L AND PFU/L OF AIR FROM PLATE DATA

a. Bacterial and viral material grown on plates are counted using the same procedure, except that either bacterial colonies or viral plaques are counted.

(1) Plate counts from bacterial spores are determined by taking three aliquots (usually 0.2 mL each) from an all-glass impinger (AGI) sample, XMX high-volume aerosol multisample collector (Technologies[®] Ltd., Edmonton, Alberta, Canada) sample, or system under test (SUT) sample. Each 0.2-mL sample is spread on an agar plate, the plate is incubated, and the number of colonies on each plate is counted. If the bacterial growth appears to be too numerous to count, appropriate dilutions must be made, and the diluted samples plated. The total counts are recorded on a spreadsheet.

(2) Plaque counts from virus materials are determined by taking three, 0.2-mL samples from an AGI sample, XMX sample, or SUT sample, spreading the samples on three plates containing host cells, incubating the plates, and counting the number of plaques on each plate. If the plaques appear too numerous to count, appropriate dilutions are made and diluted samples are re-plated. The total counts are recorded on a spreadsheet.

b. CFU/mL and PFU/mL are calculated by multiplying the average plate count by the sample dilution factor (if applicable) and by a scaling factor to scale the result to a 1-mL sample (Equation B.6).

Equation B.6

$$c = k_p f_d / V_s$$

Where:

c = the volumetric concentration expressed in biological units per mL.

k_p = the average plate count.

f_d = the dilution factor.

V_s = the sample volume in mL (usually 0.1 or 0.2 mL).

c. An average liquid volumetric concentration in biological units per mL (CFU/mL or PFU/mL) is obtained by adding the three concentration values and dividing the resulting value by three (Equation B.7). The total biological units are calculated by multiplying the average liquid volumetric concentration by the total sample volume (in mL). The total CFU is converted to CFU/L air by dividing the total CFU by the sampling time (in min) multiplied by the system airflow rate (L/min). Tables B.7 and B.8 provide an example for calculating the CFU/L and PFU/L air from a 5-min AGI sample with a total volume of 16.3 mL. Each of the triplicate samples is 200 μ L. The AGI airflow rate is 12.5 L/min.

APPENDIX B. REFEREE INSTRUMENTATION DATA REDUCTION
AND CONVERSION.

Equation B.7

$$\bar{c}_l = \frac{1}{n} \sum_{j=1}^n c_j$$

Where:

\bar{c}_l = the average liquid volumetric concentration in biological units per mL.

c_j = the liquid volumetric concentration (Equation B.6) in each sample.
in biological units per mL.

j = the index of each sample.

n = the number of samples.

d. Airflow rates and commonly used sampling times for different referee systems are provided in Table B.9.

4. CALCULATING THE AIR CHALLENGE CONCENTRATION BASED ON THE LIQUID SAMPLE CONCENTRATION

a. To calculate the air challenge concentration based on the liquid sample concentration, first calculate the total GE, CFU, PFU, or ng contained in the liquid sample (Equation B.8).

Equation B.8

$$T = \bar{c}_l V_s$$

Where:

T = the total biological units in the liquid impinger sample (GE, CFU, PFU or ng).

\bar{c}_l = the average concentration (Equation B.7) of a liquid sample in biological units/mL.

V_s = the sample volume in mL.

APPENDIX B. REFEREE INSTRUMENTATION DATA REDUCTION AND CONVERSION.

Table B.7. EXAMPLE OF CALCULATION OF COLONY-FORMING UNITS (CFU) PER LITER OF AIR (CFU/L AIR) FROM PLATE DATA.

Sample Number	Colony Counts per plate	Dilution Factor	CFU/mL ^a	Average CFU/mL	Volume of AGI ^b Sample (mL)	Total CFU	AGI Flow Rate (L air/min)	Sample Time (min)	CFU/L air		
1	46	10	$46 \times 10 \times 5 =$	2.23×10^3	16.3 ^c	$2.23 \times 10^3 \times 16.3 =$	12.5	5	$3.63 \times 10^4 / (12.5 \times 5) =$		
			2.30×10^3							3.63×10^4	5.81×10^2
2	45	10	$45 \times 10 \times 5 =$	2.23×10^3	16.3 ^c	$2.23 \times 10^3 \times 16.3 =$	12.5	5	$3.63 \times 10^4 / (12.5 \times 5) =$		
			2.25×10^3							3.63×10^4	5.81×10^2
3	43	10	$43 \times 10 \times 5 =$	2.23×10^3	16.3 ^c	$2.23 \times 10^3 \times 16.3 =$	12.5	5	$3.63 \times 10^4 / (12.5 \times 5) =$		
			2.15×10^3							3.63×10^4	5.81×10^2

^aCFU/mL – colony-forming units (CFU)/mL [determined by plating 0.2 mL of liquid bacterial sample, incubating the plate, and counting any growth].

^bThe volume of the all-glass impinger (AGI) sample is 16.3 mL in this table; however, this is an example volume, and the actual volume may vary depending upon test requirements.

APPENDIX B. REFEREE INSTRUMENTATION DATA REDUCTION AND CONVERSION.

Table B.8. EXAMPLE OF CALCULATION OF PLAQUE-FORMING UNITS (PFU) PER LITER OF AIR (PFU/L AIR) FROM PLAQUE DATA.

Sample Number	Colony Counts per Plate	Dilution Factor	PFU/mL ^a	Average PFU/mL	Volume of AGI Sample (mL) ^b	Total PFU	AGI Flow Rate (L air/min)	Sample Time (min)	PFU/L air
1	78	1	$78 \times 1 \times 5 =$	4.70×10^2	16.6	$4.70 \times 10^2 \times 16.6 =$ 7.80×10^3	12.5	5	$7.80 \times 10^3 / (12.5 \times 5) =$ 1.25×10^2
			3.90×10^2						
			$103 \times 1 \times 5 =$						
2	103	1	$103 \times 1 \times 5 =$	4.70×10^2	16.6	$4.70 \times 10^2 \times 16.6 =$ 7.80×10^3	12.5	5	$7.80 \times 10^3 / (12.5 \times 5) =$ 1.25×10^2
			5.15×10^2						
3	101	1	$101 \times 1 \times 5 =$ 5.05×10^1	4.70×10^2	16.6	$4.70 \times 10^2 \times 16.6 =$ 7.80×10^3	12.5	5	$7.80 \times 10^3 / (12.5 \times 5) =$ 1.25×10^2

^aPFU/mL – plaque-forming units/mL [determined by plating 0.2 mL of liquid virus sample, incubating the plate, and counting any growth].

^bThe volume of the all-glass impinger (AGI) sample is 16.6 mL in this table; however, this is an example volume and actual volume may vary depending upon test requirements.

APPENDIX B. REFEREE INSTRUMENTATION DATA REDUCTION
AND CONVERSION.

Table B.9. AIRFLOW RATE AND COMMONLY USED SAMPLING TIMES FOR
DIFFERENT REFEREE SYSTEMS.

System ^a	Sampling Airflow Rate (L/min)	Sampling Time (min)
STA sampler	28.3	2.0
AGI	12.5	2.0 or 5.0
XXM	600.0	1.0 or 5.0

^aSTA – slit-to-agar; AGI – all-glass impinger; XXM – XXM high-volume sampler.

b. The air concentration can then be obtained by dividing the liquid sample concentration from Equation B.8, by the sampling time multiplied by the sampling airflow rate (Equation B.9).

Equation B.9

$$c_a = \frac{T}{t_s r_s}$$

Where:

c_a = the air concentration in biological units/L of air.

T = the total biological units in the liquid impinger sample (GE, CFU, PFU, or ng) from Equation B.8.

t_s = the sampling time in minutes.

r_s = the sampling airflow rate in L/min.

5. CALCULATION OF AEROSOL CONCENTRATION IN BIOLOGICAL UNITS/L AIR FROM AEROSOL CONCENTRATION IN ACPLA

a. For an aerosol generated from a slurry, the air concentration in CFU/L air, PFU/L air, or ng/L air, can be calculated using Equation B.10. Three assumptions are made in this calculation:

- (1) The aerosol droplets are spherical.
- (2) Each slurry droplet dries to form one solid aerosol particle.
- (3) The droplets are near-monodispersed.

APPENDIX B. REFEREE INSTRUMENTATION DATA REDUCTION
AND CONVERSION.

Equation B.10 $c_a = \text{ACPLA} \times V_d \times c_s = \text{ACPLA} \times 1.56 \times 10^{-8} \times c_s$

Where:

c_a = the air concentration in biological units/L of air (Equation B.9).

ACPLA = the aerosol concentration in agent-containing particles per liter of air.

V_d = the aerosol median droplet volume.

c_s = the slurry concentration in biological units/mL.

b. For example, for a nozzle producing an aerosol with a mean droplet diameter of 31 μm , disseminating the slurry with a concentration of 5.0×10^8 CFU/mL, and achieving an aerosol concentration of 100 ACPLA, the CFU/L air can be calculated using Equation B.11.

Equation B.11 $c_a = 100 \times 1.56 \times 10^{-8} \times 5.0 \times 10^8 = 780 \text{ CFU/L}$

Where:

c_a = the air concentration in biological units/L of air (Equation B.9).

6. CALCULATING AEROSOL PARTICLE CONCENTRATION FROM GE OF AGENT-LIKE ORGANISM (ALO) OR SIMULANT

a. This critical computation allows testers to correlate values from biological warfare agent (BWA) with ALO or simulant aerosolization. There are inherent errors that force careful consideration when making such a comparison and when using the values generated. There are two instances where use of this conversion is essential:

(1) When ACPLA values cannot be directly calculated from known dissemination and operating parameters such as dissemination rates, number of particles generated, and chamber volumetric flow rates.

(2) During field disseminations when concentrations are below natural background levels.

b. Calculating ACPLA from GE/mL is done through the use of a conversion factor. The conversion factor can be found for live materials using the ratio of the stock culture CFU/mL or PFU/mL to GE/mL, and for inactivated materials by using the ratio of the stock culture CFU/mL or PFU/mL to the irradiated GE/mL. The concentration of the stock culture should be determined by PCR analysis and plate count or plaque assay as soon as possible after production. This will provide the most accurate ratio of live to genetic quantities. For inactivated biological ALO or simulants, the PCR analysis value should also be determined after the ALO/simulant has been killed or inactivated. This procedure provides data to determine the amount of genetic material destroyed in the deactivation process. A typical PCR analysis result from a field sample is given in GE/mL. ACPLA from GE/mL can be calculated using Equation B.12.

APPENDIX B. REFEREE INSTRUMENTATION DATA REDUCTION AND CONVERSION.

Equation B.12

$$\text{ACPLA} = \frac{c_g V_s f_c}{V_a \rho_b}$$

Where:

c_g = the concentration of ALO or simulant in the liquid sample in GE/mL.

V_s = the liquid sample volume in mL.

f_c = the conversion factor in CFU/mL or PFU/mL per GE.

V_a = the volume of air sampled.

ρ_b = the average number of biological units per droplet (value from Appendix A, Paragraph k, Equation A.7).

7. TIME-SERIES AVERAGE APS™ PARTICLE CONCENTRATION

For an environment with negligible background noise, the time-series average concentration of aerosol particles per liter of air can be estimated for different time lengths using Equation B.4 applied to the number of particles collected at each time step. The number of particles collected over a time period is the sum over all size bins (Equation B.13).

Equation B.13

$$b_\tau = \sum_{i=1}^N b_{\tau,i}$$

Where:

b_τ = the number of particles collected at time step.

$b_{\tau,i}$ = the number of particles in each size bin at each time step.

i = the bin index, each bin corresponds to a particle size.

τ = the index of each time step.

N = the number of particle size bins.

8. CALCULATIONS OF APS™ NMAD

a. The NMAD value is calculated by using data collected after the disseminated aerosol concentration has reached a steady state. In a controlled chamber environment a steady-state aerosol concentration is typically reached after three chamber-volume air exchanges. A good estimation of the NMAD value can be obtained by sampling an aerosol with an APS™ for 2 minutes after the aerosol has reached a steady-state concentration.

APPENDIX B. REFEREE INSTRUMENTATION DATA REDUCTION
AND CONVERSION.

b. In general, the number of particles contained in the first APSTM size bin ($<0.523 \mu\text{m}$) are not considered for the NMAD calculation because:

- (1) Particles less than $0.523 \mu\text{m}$ in diameter are not representative of typical BWA threats.
- (2) The aerosol generated by a Sono-Tek nozzle produces a narrow range of particles distributed around the desired NMAD bin value with very small number of particles below $1 \mu\text{m}$ in diameter.
- (3) Particles less than $0.523 \mu\text{m}$ are mainly chamber background particles.

c. Chamber background particles are the aerosolized particles that occur in the chamber without the intentional dissemination of an aerosol. Figure B.1 provides a typical particle distribution for a $2.5\text{-}\mu\text{m}$ aerosol cloud in a clean chamber environment generated with Sono-Tek nozzle (Model 8700-60) producing $31\text{-}\mu\text{m}$ droplets. The particle distribution in Figure B.1 was obtained by calculating for each APSTM bin the average percentage number of particles from the total number of particles observed during 7 minutes of steady-state aerosol dissemination from 145 trials.

APPENDIX B. REFEREE INSTRUMENTATION DATA REDUCTION
 AND CONVERSION.

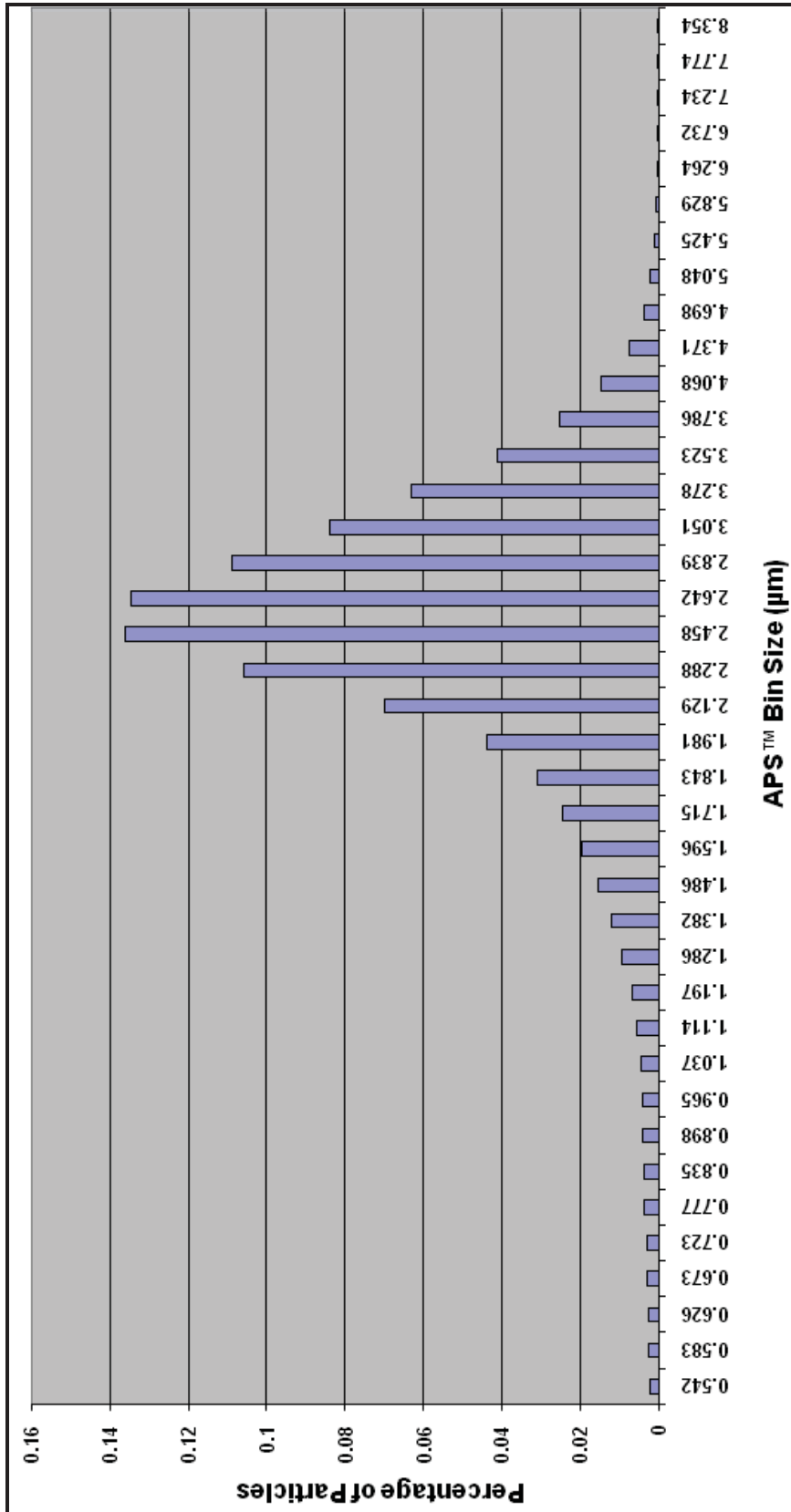

NOTE: The aerosol was generated with a Sono-Tek nozzle (Sono-Tek Corporation, Milton, New York) producing 3 1-µm droplets. The sample of aerosol was collected and analyzed by an Aerodynamic Particle Sizer® (APS™, TSI Inc., Shoreview, Minnesota).

Figure B.1. Average particle distribution for a 2.5-µm number mean aerodynamic diameter (NMAD) aerosol.

APPENDIX B. REFEREE INSTRUMENTATION DATA REDUCTION
AND CONVERSION.

d. For an environment with negligible background noise, the NMAD can be calculated by finding the bin that contains the particles in the fiftieth percentile. The total number of particles must be calculated (Equation B.14).

Equation B.14

$$N_t = \sum_i \sum_{\tau} b_{\tau,i}$$

Where:

- N_t = the total number of particles collected over the duration of the trial.
- $b_{\tau,i}$ = the number of particles in each size bin at each time step.
- i = the bin index, each bin corresponds to a particle size.
- τ = the index of each time step.

e. Then percentiles are calculated using Equation B.15. The NMAD is the smallest particle size bin where p_k is greater than 50 percent.

Equation B.15

$$p_k = \frac{1}{N_t} \sum_{i=1}^k b_i$$

Where:

- p_k = the percentile of the bin with index k .
- N_t = the total number of particles collected over the duration of the trial from Equation B.14.
- b_i = the number of particles in each bin through the duration of the trial from Equation B.16.
- i = the bin index, each bin corresponds to a particle size.
- k = the number of data points in the moving average.

Equation B.16

$$b_i = \sum_{\tau=0}^{\tau_{end}} b_{\tau,i}$$

Where:

- b_i = the total number of particles in each bin through the duration of the trial.
- τ = the index of each time step.
- τ_{end} = the index of the last time step (it is also the total number of time steps).
- $b_{\tau,i}$ = the number of particles in each size bin at each time step.

APPENDIX B. REFEREE INSTRUMENTATION DATA REDUCTION
AND CONVERSION.

9. CALCULATION OF APS™ MMAD

a. The MMAD value is calculated by using data after the disseminated aerosol concentration has reached a steady state. In a controlled chamber environment, a steady-state aerosol concentration is typically reached after three chamber volume air exchanges. A good estimation of the MMAD value can be obtained by sampling an aerosol with an APS™ for 2 minutes after the aerosol has reached a steady-state concentration.

b. In general, the number of particles contained in the first APS™ bin (<0.523 μm) are not considered for the MMAD calculation because: 1) Particles in the <0.523-μm bin are not BWA threat representative; 2) The aerosol generated by a Sono-Tek nozzle produces a narrow range of particles centered about the desired NMAD bin value with a very small number of particles below 1 μm; and 3) Particles in the 0.523-μm bin are mainly chamber background particles. Chamber background particles are the concentration of aerosolized particles occurring in a chamber without the explicit or intentional dissemination of an aerosol. For an environment with negligible background, the MMAD can be calculated by summing all the particles in each size bin (Equation B.16), then calculating the mass for each bin (Equation B.17); then the total mass is calculated (Equation B.18), and finally the percentiles of each bin are calculated (Equation B.19) and the MMAD found.

Equation B.17 $m_i = \frac{\pi}{6} d_i^3 b_i \rho$

Where:

m_i = the mass in each size bin in picograms (pg).

d_i = the aerodynamic diameter of each size bin in μm.

b_i = the number of particles in each size bin through the duration of the trial (Equation B.16).

ρ = the density of the dry aerosol particles (formed from the slurry) in g/mL.

Equation B.18 $m_{tot} = \sum_i m_i$

Where:

m_i = the mass in each size bin in pg (Equation B.17).

m_{tot} = the total mass of all particles in pg.

i = the bin index, each bin corresponds to a particle size.

APPENDIX B. REFEREE INSTRUMENTATION DATA REDUCTION
AND CONVERSION.

Equation B.19

$$p_k = \frac{1}{m_{tot}} \sum_{i=1}^k m_i$$

Where:

- p_k = the mass percentile of the bin with index k .
- m_{tot} = the total mass in pg (calculated in Equation B.18).
- m_i = the mass in each size bin in pg (calculated in Equation B.17).
- i = the index of each particle size bin.
- k = the number of data points in the moving average.

c. The MMAD is the aerodynamic diameter of the first bin with a percentile greater than 50 percent.

10. ESTIMATION OF AEROSOL CONCENTRATION FROM ATOMIZED SLURRY IN
THE AMBIENT BREEZE TUNNEL (ABT) CHAMBER

a. An estimate of the average aerosol concentration in particles/L of air in the ABT can be obtained if the slurry dissemination feed rate and the size of the aerosol droplets are known (Equation B.20). The aerosol droplet volume is calculated in Equation B.21.

Equation B.20

$$\bar{c}_p = \frac{S}{60000AWV_d}$$

Where:

- \bar{c}_p = the average aerosol particle concentration in particles per liter of air.
- S = the slurry dissemination rate in mL/min.
- A = the cross-sectional area of the of the breeze tunnel in m² (33.17 m² in the ABT).
- W = average breeze tunnel wind speed in m/sec.
- V_d = the aerosol median droplet volume in mL (Equation B.21).

Equation B.21

$$V_d = \frac{\pi d^3}{6}$$

Where:

- V_d = the aerosol median droplet volume in mL (Equation B.21).
- d = the particle mass median diameter in cm.

APPENDIX B. REFEREE INSTRUMENTATION DATA REDUCTION
AND CONVERSION.

b. An example is given in Equation B.22 using Equation B.21. For a nozzle producing an aerosol with a mean droplet diameter of 31 μm , the volume per droplet of disseminated slurry (V_d) is calculated in Equation B.22:

$$\text{Equation B.22} \quad V_d = \frac{\pi d^3}{6} = \frac{\pi(31 \times 10^{-4} \text{ cm})^3}{6} = 1.56 \times 10^{-8} \text{ mL}$$

Where:

V_d = the aerosol median droplet volume in mL.

d = the median diameter in cm.

c. Example for Equation B.20. The ABT has a cross-sectional area of 33.17 m^2 . If an aerosol is generated in the ABT at a feed rate of 4 mL/min and with an average ABT wind speed of 1 m/sec, the estimated average aerosol concentration (C) is calculated in Equation B.23:

$$\text{Equation B.23} \quad c = \frac{S}{60000AWV_d} = \frac{4}{60000 \times 33.17 \times 1 \times 1.56 \times 10^{-8}} = 129 \text{ particle/L}$$

Where:

S = the slurry dissemination rate in mL/min.

V_d = the aerosol median droplet volume in mL.

A = the cross-sectional area of the of the breeze tunnel in m^2 (33.17 m^2 in the ABT).

W = the average breeze tunnel wind speed in m/sec.

11. AEROSOL CHAMBER BACKGROUND PARTICLE CONSIDERATIONS

a. While conducting testing in bio-aerosol chambers, it is important to keep the concentration of chamber background particles as low as possible to avoid affecting the performance of the biological point detector being tested. Also the presence of background particles during challenge aerosol dissemination skews the NMAD, MMAD, and aerosol concentration calculations. Chamber background particles are sometimes generated by electric motors belonging to the SUT or to referee instrumentation electric motors, or the particles may be residual from previous testing in the chamber.

APPENDIX B. REFEREE INSTRUMENTATION DATA REDUCTION
AND CONVERSION.

b. If the average particle distributions of the challenge aerosol and background particles are known, then the background particles included in the data collected by the APS™ can be subtracted from the NMAD, MMAD, and aerosol concentration calculations. In general, the particle distribution of the challenge aerosol without background particles is dependent on the nozzle used to aerosolize the slurry, the type of slurry, and the target size of the particle being aerosolized.

(1) A background particle distribution should be determined before testing begins. Background samples are collected as long as the TO ensures that the background concentration appears stable for at least 2 minutes. Once the concentration is stable for 2 minutes, background samples are collected for 3 minutes.

(2) The background distribution is generated by averaging the number of particles in each size bin collected during the 3-min background data collection period (Equation B.24).

Equation B.24

$$B_i = \frac{1}{N} \sum_{\tau=1}^{\tau_{end}} b_{\tau,i}$$

Where:

B_i = the average background particle count for the i^{th} bin.

N = the number of particle size bins.

$b_{\tau,i}$ = the number of particles in each size bin at each time step.

τ = the index of each time step.

τ_{end} = the index of the last time step (it is also the total number of time steps).

(3) The data collected during a trial is corrected by subtracting the background distribution (Equation B.24) by using Equation B.25. This process is visually depicted in Figure B.2.

Equation B.25

$$a_{\tau,i} = b_{\tau,i} - B_i \mid 1 \leq i \leq N$$

Where:

$a_{\tau,i}$ = the background corrected to the i^{th} particle size at time t .

$b_{\tau,i}$ = the number of particles in each size bin at each time step.

B_i = the average background particle count for the i^{th} bin.

N = the number of particle size bins.

i = the index of each particle size bin.

(4) An estimate of the NMAD, MMAD, and aerosol concentrations can then be obtained from this synthetic distribution.

APPENDIX B. REFEREE INSTRUMENTATION DATA REDUCTION
AND CONVERSION.

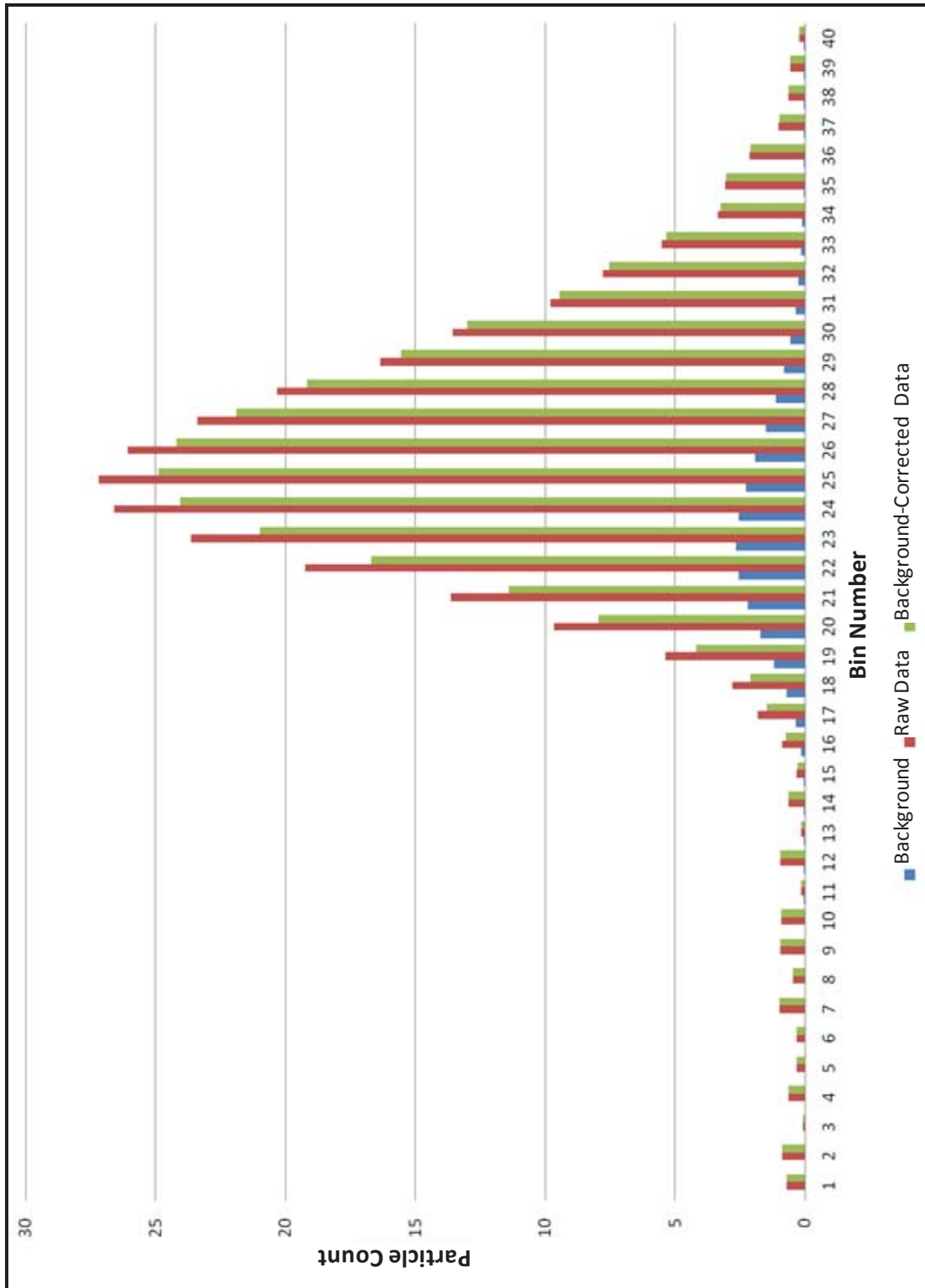

Figure B.2. Process of subtracting the background particle distribution from collected trial data.

(This page is intentionally blank.)

APPENDIX C. AEROSOL SIMULANT EXPOSURE CHAMBER (ASEC)
CONFIGURATION.

TABLE LIST

<u>TABLE</u>	<u>PAGE</u>
C.1 NOZZLE POSITION, MIXING FAN HEIGHT, AND FAN ANGLE IN THE AEROSOL SIMULANT EXPOSURE CHAMBER (ASEC).....	C-3
C.2 AUXILIARY MIXING FAN SPECIFICATIONS FOR COMPARISON.	C-3

FIGURE LIST

FIGURE

FIGURE LIST

<u>FIGURE</u>	<u>PAGE</u>
C.1 Aerosol simulant exposure chamber (ASEC) configuration.	C-2
C 2 Schematic detail for dissemination nozzle mounting in the aerosol simulant exposure chamber (ASEC).	C-3

APPENDIX C. AEROSOL SIMULANT EXPOSURE CHAMBER (ASEC)
CONFIGURATION.

With the Aerosol Simulant Exposure Chamber (ASEC) configured, a homogeneous aerosol mixing is achieved in a subspace of $3.05 \times 3.05 \times 1.22$ m (L \times W \times H) located in the center of the ASEC (Figure C.1). A set of four auxiliary wall mixing fans are located at the middle of the walls, at locations A, B, C, and D, at a height of 1.83 m, as shown in Figure C.2 and Table C.1. The dissemination nozzle is positioned at a height of 2.59 m above the ground, at a horizontal angle of 135 degrees from the surface of the wall and a vertical angle of 90 degrees, as shown in Figure C.2. The chamber exhaust blower is automatically adjusted to maintain a negative pressure inside the ASEC. Table C.1 provides the different parameters (height and angle) for the dissemination nozzle and auxiliary wall mixing fans. Table C.2 provides the specifications for the auxiliary wall mixing fans so comparisons can be made and equivalent fans found, if needed.

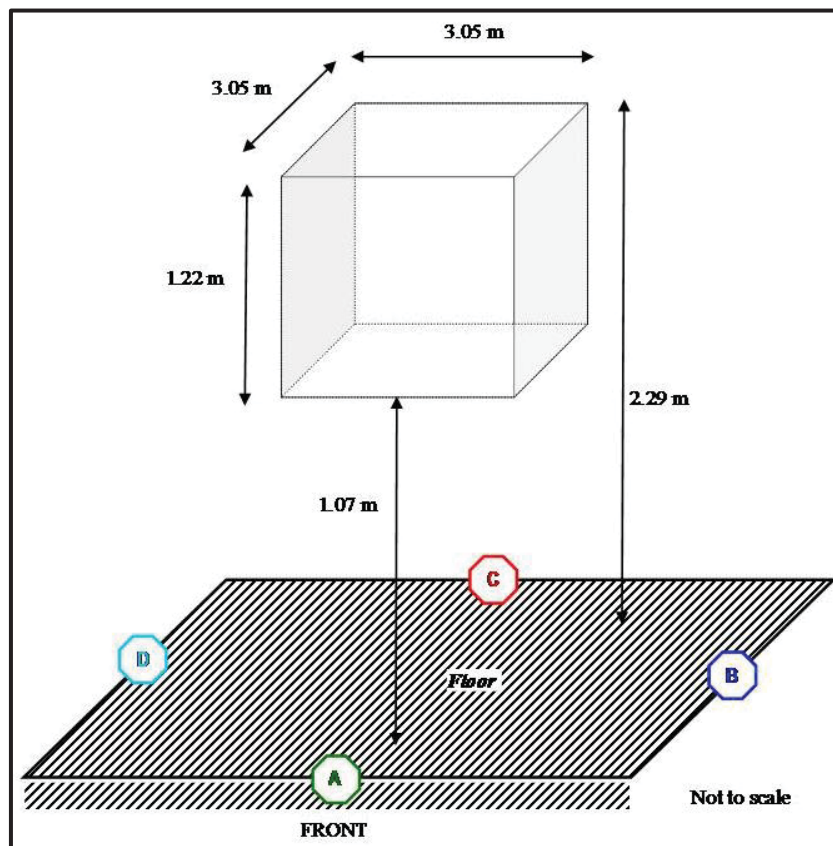

NOTE: A, B, C, and D indicate the locations for mixing fans at height of 1.83 m.

Figure C.1. Aerosol simulant exposure chamber (ASEC) configuration.

APPENDIX C. AEROSOL SIMULANT EXPOSURE CHAMBER (ASEC)
CONFIGURATION.

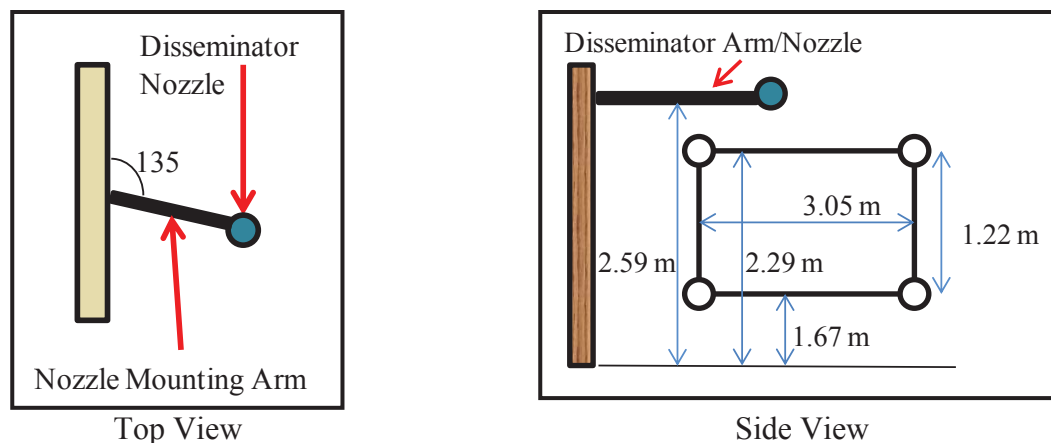

NOTE: Not to scale. Fans, not shown, are at height of 1.83 m.

Figure C.2. Schematic detail for dissemination nozzle mounting in the aerosol simulant exposure chamber (ASEC).

Table C.1. NOZZLE POSITION, MIXING FAN HEIGHT, AND FAN ANGLE IN THE AEROSOL SIMULANT EXPOSURE CHAMBER (ASEC).

Dissemination Nozzle Height	Nozzle Mounting Angle (Degrees)	Auxiliary Mixing Fan Location ^a	Auxiliary Fan Height (m)	Auxiliary Fan Vertical Angle (Degrees)
2.59 m	Vertical: 90 Horizontal: 135	A	1.83	21
		B	1.83	7
		C	1.83	14
		D	1.83	0

^aSee Figure C.1 for the key to fan locations.

Table C.2. AUXILIARY MIXING FAN SPECIFICATIONS FOR COMPARISON.

Description	Specification
Quantity	4 units
Manufacturer	Caravel, Comair Rotron Inc., Shanghai, China
Model	CLE2T2
Part Number	020189
Power Requirements	115 volts (V), alternating current (AC), 0.5 Amperes (Amp)
Airflow	0.26 m ³ /sec
Dimensions	Fan size: 25.4 cm (round); fan depth: 8.9 cm

(This page is intentionally blank.)

APPENDIX D. ABBREVIATIONS.

ABI	Applied Biosystems Incorporated
ABO	agent of biological origin
ABT	Ambient Breeze Tunnel
AC	alternating current
ACPLA	agent-containing particles per liter of air
AD No.	accession number
AGI	all-glass impinger
ALO	agent-like organism
ALO-I	ALO-inactivated
amp	ampere
APST TM	Aerodynamic Particle Sizer [®]
ASEC	Aerosol Simulant Exposure Chamber
ATEC	U.S. Army Test and Evaluation Command
BG	<i>Bacillus atrophaeus</i>
BG-I	BG-inactivated
BMBL	Biosafety in Microbiological and Biomedical Laboratories
BSC	biological safety cabinet
BSL	biosafety level
BWA	biological warfare agent
CAC	Containment Aerosol Chamber
CC	colony count
CFU	colony-forming units
CRP	Critical Reagents Program
DA	Department of the Army
DAG	Data Authentication Group

APPENDIX D. ABBREVIATIONS.

DCC	Detector Challenge Chamber
DMP	data management plan
DNA	deoxyribonucleic acid
DPG	U.S. Army Dugway Proving Ground
EA	environmental assessment
ECL	electrochemiluminescence
EIS	environmental impact statement
EMT	emergency medical technician
FCR	final command review
GE	genomic equivalents
HEPA	high-efficiency particulate air (filter)
IAW	in accordance with
JPEO-CBD	Joint Program Executive Office for Chemical and Biological Defense
LOI	letter of instruction
LSTF	Life Sciences Test Facility
MMAD	mass median aerodynamic diameter
NA	not applicable
ng	nanograms
NMAD	number median aerodynamic diameter

APPENDIX D. ABBREVIATIONS.

OPSEC	operations security
ORI	operational readiness inspection
PAM	pamphlet
PBS	phosphate-buffered saline
PCR	polymerase chain reaction
PFU	plaque-forming units
pg	picograms
PI	principal investigator
Po/L	concentration of aerosol particles per liter of air without background particles
POSS	preoperational safety survey
QA	quality assurance
QC	quality control
RH	relative humidity
RNA	ribonucleic acid
RO	responsible officer
RT	reverse-transcriptase
RT-qPCR	RT-quantitative PCR
SABIC	Saudi Basic Industries Corporation
SAR	safety assessment report
SIP	Special Immunization Program
SMA	simple moving average
SOP	standing operating procedure
STA	slit-to-agar

APPENDIX D. ABBREVIATIONS.

SUT	system under test
T&E	test and evaluation
TCO	test control officer
TO	test officer
TOP	test operations procedure
UTC	Coordinated Universal Time
V	volt
VDLS	VISION Digital Library System
VEE	Venezuelan equine encephalitis
VISION	Versatile Information Systems Integrated ON-line
WDTC	West Desert Test Center
WSLAT	Whole-System Live Agent Test
XXM	XXM high-volume aerosol multisample collector

APPENDIX E. REFERENCES.

Required References

1. U.S. Army Dugway Proving Ground (DPG), Utah, Final Test Report for the Production Verification Test (PVT) Record Test Phase (RTP) of the Whole System Live Agent Test (WSLAT) Joint Biological Point Detection System (JBPDS), U.S. Army Test and Evaluation Command (ATEC) Project Number 2008-DT-DPG-WSLAX-C8359, West Desert Test Center (WDTC) Document Number WDTC-TR-08-043, June 2008.
2. U.S. Army Dugway Proving Ground (DPG), Utah, Final Test Report for the Whole-System Live Agent Test (WSLAT) of the Joint Biological Point Detection System (JBPDS), Army Test and Evaluation Command (ATEC) Project Number 2010-DT-DPG-JBPDS-E6799, West Desert Test Center (WDTC) Document Number WDTC-TR-11-015, 27 April 2011.
3. Dycor Technologies Ltd., Edmonton, Alberta, Canada, XMX/2L-102 Operations Manual, Revision 1.3, Document Number: 04110_MAN_R1_4.doc.
4. U.S. Army Dugway Proving Ground (DPG), Utah, Standing Operating Procedure (SOP) WDL-WI-AER-205**, Coms of Slit to Agar Microbiological Air Samples, Revision 8, 6 July 2012.
5. U.S. Army Dugway Proving Ground (DPG), Utah, Standing Operating Procedure (SOP) WDL-WI-AER-212**, Calibration, Operation, and Maintenance of All-Glass Impingers (AGI) for Field Tests, Revision 8, 17 December 2012.
6. U.S. Army Dugway Proving Ground (DPG), Utah, Standing Operating Procedure (SOP) WDL-WI-AER-203**, Operation and Maintenance of Aerodynamic Particle Sizer (APS), Revision 7, 25 July 2012.
7. U.S. Army Dugway Proving Ground (DPG), Utah, Handbook WDL-HBK-BIO-001, Handbook of Procedures Used to Produce Biological Materials for Testing Defense Systems; Developed for the Whole System Live Agent Test Program.
8. U.S. Army Dugway Proving Ground (DPG), Utah, Standing Operating Procedure (SOP) WDL-WI-BIO-097**, Electrochemiluminescence (ECL) Assays, Revision 4, 25 February 2013.
9. U.S. Army Dugway Proving Ground (DPG), Utah, Standing Operating Procedure (SOP) WDL-WI-BIO-094**, Determination of Genome Equivalents by Real-Time Quantitative Polymerase Chain Reaction, Revision 4, 9 May 2013.
10. Headquarters, Department of the Army (DA), Washington, DC, Pamphlet (PAM) 385-69, Safety Standards for Microbiological and Biomedical Laboratories, 6 May 2009.
11. Center for Disease Control and Prevention (CDC), Biosafety in Microbiological and Biomedical Laboratories, 4th edition, April 1999.

APPENDIX E. REFERENCES.

12. U.S. Army Dugway Proving Ground (DPG), Utah, Standing Operating Procedure (SOP) WDL-WI-AER-207**, Calibration, Operation, and Maintenance of Aerosol Simulant Exposure Chamber (ASEC), Revision 8, 27 June 2012.
13. U.S. Army Dugway Proving Ground (DPG), Utah, Standing Operating Procedure (SOP) WDL-AER-201**, Calibration, Operation and Maintenance of the Containment Aerosol Chamber, Revision 8, Change 1, 18 April 2013.
14. U.S. Army Dugway Proving Ground (DPG), Utah, Manual, LSD-002**, Life Sciences Test Facility Biological Safety Manual, Revision 6, 4 June 2012.
15. U.S. Army Dugway Proving Ground (DPG), Utah, Standing Operating Procedure (SOP) WDL-BIO-147**, Inactivation of Biological Agents and Simulants for Antigen Production Revision 6, 26 February 2013.
16. Sono-Tek Corporation, Milton, New York, Ultrasonic Atomizing Nozzle Systems Operating Instructions for Use With Models 06-5108 and 06-05112 Broadband Ultrasonic Generators, Version 1.4, Part Number 11-01049.
17. U.S. Army Dugway Proving Ground (DPG), Utah, Standing Operating Procedure (SOP) DP-0000-D-216**, Preparation, Calibration, and Operation of Dissemination Equipment, Revision 9, 21 May 2013.

**The inclusion of SOPs is only to serve as an example of these type procedures that are used at DPG and as a reference for other installations. Many SOPs are specific to a particular installation, facility, or instrument, and may not be applicable between different installations, facilities, or instruments without modifications. It is expected that installations will have their own equivalent SOPs. These equivalent SOPs must be provided to the T&E community interested in this test method in order to properly understand the data produced and any differences between test method implementation between installations, which impacts the ability to compare data produced by different installations. If an installation does not have an equivalent SOP already in place, these or other similar procedures could be used as temporary guides until appropriate SOPs are developed. The most current version of these SOPs can be requested through ATEC or through access to Versatile Information Systems Integrated Online Nationwide (VISION) Digital Library System (VDLS).

APPENDIX F. APPROVAL AUTHORITY.

CAPAT Cover Sheet

**TEST OPERATIONS PROCEDURE (TOP) 08-02-066A
AEROSOL TESTING OF BIOLOGICAL POINT DETECTION SYSTEMS**

Bio Surveillance Commodity Area Process Action Team (CAPAT)

Primary Authors: K. Wing Tsang and Aaron B. Thomas, U.S. Army Dugway Proving Ground (DPG)







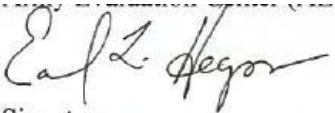

Key Contributors: Allyssa Martinez, Deborah Beier, and Nyle Critchlow, Dugway Data Services Team (DDST), Scot Westwood, DPG

Biological Surveillance CAPAT Review & Concurrence: April 2013

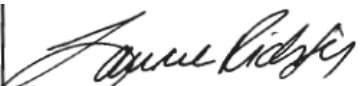

APPENDIX F. APPROVAL AUTHORITY.

The Biological Surveillance Capability Area Process Action Team (CAPAT) of the Test and Evaluation Capabilities and Methodologies Integrated Process Action Team (TECMIPT) recommends approval of *TOP 08-2-066A, Test Operations Procedure for Aerosol Testing of Biological Point Detection Systems*. If a representative non-concurs, a dissenting position paper will be attached.

Concurrence Sheet for the TOP 08-2-066A, Test Operations Procedure for Aerosol Testing of Biological Point Detection Systems	
Kevin P. Reilly, Lt Col, USMC Marine Corps Operational Test & Evaluation Activity (MCOTEA)  Signature Date 4 APR 2013	Earl Heaps US Army Test and Evaluation Command (ATEC)/US Army Evaluation Center (AEC)  Signature Date 3/12/13
Nevin K. Elden, Col, USAF (for) Vice Commander, US Air Force Operational Test and Evaluation Center (AFOTEC)  Signature Date 26 Nov 12	Laurie K. Richter, Lt Col, USAF Joint Requirements Office (JRO) for Chemical, Biological, Radio logical, and Nuclear Defense  Signature Date 10 Apr 13
Jeffery Bobrow Assistant Chief of Staff, Expeditionary Warfare Commander Operational Test and Evaluation Force (COMOPTEVFOR)  Signature Date 19 Nov 2012	Deborah F. Shuping CBRN Defense (CBRND) T&E Executive  Signature Date 3/4/13
Curt Wilhide Joint Program Executive Office for Chemical Biological Defense (JPEO-CBD)  Signature Date 12 Apr 2013	Michael Roberts Joint Science and Technology Office (JSTO)  Signature Date 3/4/13
Jeffery Hogan Biological Surveillance CAPAT Chair  Signature Date 15 APR 2013	

NOTE: CAPAT member's signature represents an 06 level concurrence from their organization. If the CAPAT representative is not empowered at this level, he/she must coordinate the concurrence/nonconcurrence process within his/her organization, and prior to the specified suspense date for the document.

APPENDIX F. APPROVAL AUTHORITY

T&E Capabilities and Methodologies Integrated Process Team (TECMIPT) Chair Endorsement

AMXAA-CD

10 July 2013

MEMORANDUM FOR

Chemical, Biological, Radiological and Nuclear Defense (CBRND) Test and Evaluation (T&E) Executive, Office of the Deputy Under Secretary of the Army, Taylor Building, Suite 8070, 2530 Crystal Drive, Arlington, VA 22202

SUBJECT: Test and Evaluation Capabilities and Methodologies Integrated Process Team (TECMIPT) Test Operations Procedure (TTOP) 08-2-066 for Aerosol Testing of Biological Point Detection Systems

1. The Biological Surveillance Capability Area Process Action Team (CAPAT) has completed their review of the subject TTOP in accordance with the DUSA-TE Instructions to the TECMIPT, the Standards and Development Plan, and the TECMIPT Standard Operating Procedure (SOP). All signatory members of the CAPAT have provided their concurrence to this TTOP. The CAPAT signature sheets and the ATEC Approval for Publication memorandum are enclosed.
2. Based on the concurrence of the CAPAT, I recommend the CBRND T&E Executive endorse this TTOP as a Department of Defense (DoD) Test and Evaluation (T&E) Standard.

Encl



RONALD O. PRESCOTT
TECMIPT Chair

APPENDIX F. APPROVAL AUTHORITY

Deputy Under Secretary of the Army Endorsement



DEPARTMENT OF THE ARMY
OFFICE OF THE DEPUTY UNDER SECRETARY OF THE ARMY
102 ARMY PENTAGON
WASHINGTON, DC 20310-0102

DUSA-TE

MEMORANDUM FOR DISTRIBUTION

SUBJECT: Endorsement of TECMIPT Test Operations Procedure (TTOP) 08-2-066, Aerosol Testing of Biological Point Detection Systems

1. Reference: Memorandum, DUSA-TE, 19 July 10, subject: Chemical and Biological Defense Program (CBDP) Test and Evaluation (T&E) Standards Development Plan.
2. I endorse TTOP 08-2-066 as a DoD T&E Standard for biological point detection testing and encourage its broad use across all test phases.
3. All T&E Standards are for government associated program access and use. They are stored in Army Knowledge Online (AKO), located at <https://www.us.army.mil/suite/files/22142943> and on the National Institute of Standards and Technology (NIST) website at <http://gsi.nist.gov/global/index.cfm/L1-4/L2-19/A-664>.
4. My point of contact for this action is Ms. Deborah Shuping, (703) 545-1119, deborah.f.shuping.civ@mail.mil.

Encl

JAMES C. COOKE
CBRN Defense T&E Executive

DISTRIBUTION:
DASD(CBD)
DASD(DT&E)
DOT&E, Deputy for Land and Expeditionary Warfare
Army G3/5/7
Army G8 (DAPR-FDZ-I)
AF-TE
CNO, N091
Commanding General, ATEC
Commander, AFOTEC
JSTO-CBD

APPENDIX F. APPROVAL AUTHORITY.

"

*****Cr r tqxcn'ht 'Rwdrlccv'qp. 'F k'gevt. 'Vguv'O pci go gpv'F k'gevtcvg'†I ; ± 'CVGE/J S "

CSTE-TM

5 July 2013

MEMORANDUM FOR

Commanders, All Test Centers
Technical Directors, All Test Centers
Directors, US Army Evaluation Center
US Army Operational Test Command

SUBJECT: Test Operations Procedure (TOP) 08-2-066A, Aerosol Testing of Biological Point Detection Systems, Approved for Publication

1. TOP 08-2-066A, Aerosol Testing of Biological Point Detection Systems, has been reviewed by the US Army Test and Evaluation Command (ATEC) Test Centers, the US Army Operational Test Command, and the US Army Evaluation Center. All comments received during the formal coordination period have been adjudicated by the preparing agency. The scope of the document is as follows:

This TOP provides guidelines for designing and conducting chamber and Ambient Breeze Tunnel tests involving the aerosolization of biological warfare agents and stimulants, and for collecting referee data using currently available referee equipment.

2. This document is approved for publication and has been posted to the Reference Library of the ATEC Vision Digital Library System (VDLS). The VDLS website can be accessed at <https://vdlc.atc.army.mil/>.

3. Comments, suggestions, or questions on this document should be addressed to US Army Test and Evaluation Command (CSTE-TM), 2202 Aberdeen Boulevard-Third Floor, Aberdeen Proving Ground, MD 21005-5001; or e-mailed to usarmy.apg.atec.mbx.atec-standards@mail.mil.

Fontaine.RAYMO
ND.G.1228612770
Digitally signed by
FONTAINE RAYMOND G. 1228612770
DN: cn=RAYMOND G. FONTAINE, ou=ATEC,
ou=AFM, ou=USDA,
ou=FONTAINE RAYMOND G. 1228612770
Date: 2013.07.08 08:34:47 -0400

MICHAEL J. ZWIEBEL
Director, Test Management Directorate (G9)

(This page is intentionally blank.)

Forward comments, recommended changes, or any pertinent data which may be of use in improving this publication to the following address: Range Infrastructure Division (CSTE-TM), US Army Test and Evaluation Command, 2202 Aberdeen Boulevard, Aberdeen Proving Ground, Maryland 21005-5001. Technical information may be obtained from the preparing activity: Commander, West Desert Test Center, U.S. Army Dugway Proving Ground, ATTN: TEDT-DPW, Dugway, UT 84022-5000. Additional copies can be requested through the following website: <http://itops.dtc.army.mil/RequestForDocuments.aspx>, or through the Defense Technical Information Center, 8725 John J. Kingman Rd., STE 0944, Fort Belvoir, VA 22060-6218. This document is identified by the accession number (AD No.) printed on the first page.