



AFRL-RQ-WP-TP-2013-0210

**STANDARDIZED FAULT-TOLERANT SENSING NODES
FOR AN INTELLIGENT TURBINE ENGINE CONTROL
SYSTEM (PREPRINT)**

Mike Willett

Orbital Research, Inc./Linear Dimension, Inc.

Alireza R. Behbahani

**Engine Systems Branch
Turbine Engine Division**

MAY 2013

Approved for public release; distribution unlimited.

See additional restrictions described on inside pages

STINFO COPY

© 2013 ISA

**AIR FORCE RESEARCH LABORATORY
AEROSPACE SYSTEMS DIRECTORATE
WRIGHT-PATTERSON AIR FORCE BASE, OH 45433-7542
AIR FORCE MATERIEL COMMAND
UNITED STATES AIR FORCE**

NOTICE AND SIGNATURE PAGE

Using Government drawings, specifications, or other data included in this document for any purpose other than Government procurement does not in any way obligate the U.S. Government. The fact that the Government formulated or supplied the drawings, specifications, or other data does not license the holder or any other person or corporation; or convey any rights or permission to manufacture, use, or sell any patented invention that may relate to them.

This report was cleared for public release by the USAF 88th Air Base Wing (88 ABW) Public Affairs Office (PAO) and is available to the general public, including foreign nationals.

Copies may be obtained from the Defense Technical Information Center (DTIC)
(<http://www.dtic.mil>).

AFRL-RQ-WP-TP-2013-0210 HAS BEEN REVIEWED AND IS APPROVED FOR PUBLICATION IN ACCORDANCE WITH ASSIGNED DISTRIBUTION STATEMENT.

**//Signature//*

ALIREZA R. BEHBAHANI
Project Manager
Engine Systems Branch
Turbine Engine Division

//Signature//

CARLOS A. ARANA, Chief
Engine Systems Branch
Turbine Engine Division
Aerospace Systems Directorate

This report is published in the interest of scientific and technical information exchange, and its publication does not constitute the Government's approval or disapproval of its ideas or findings.

Disseminated copies will show "//Signature//*" stamped or typed above the signature blocks.

REPORT DOCUMENTATION PAGE				<i>Form Approved OMB No. 0704-0188</i>	
<p>The public reporting burden for this collection of information is estimated to average 1 hour per response, including the time for reviewing instructions, searching existing data sources, gathering and maintaining the data needed, and completing and reviewing the collection of information. Send comments regarding this burden estimate or any other aspect of this collection of information, including suggestions for reducing this burden, to Department of Defense, Washington Headquarters Services, Directorate for Information Operations and Reports (0704-0188), 1215 Jefferson Davis Highway, Suite 1204, Arlington, VA 22202-4302. Respondents should be aware that notwithstanding any other provision of law, no person shall be subject to any penalty for failing to comply with a collection of information if it does not display a currently valid OMB control number. PLEASE DO NOT RETURN YOUR FORM TO THE ABOVE ADDRESS.</p>					
1. REPORT DATE (DD-MM-YY) May 2013		2. REPORT TYPE Conference Paper Preprint		3. DATES COVERED (From - To) 01 December 2012 – 16 May 2013	
4. TITLE AND SUBTITLE STANDARDIZED FAULT-TOLERANT SENSING NODES FOR AN INTELLIGENT TURBINE ENGINE CONTROL SYSTEM (PREPRINT)				5a. CONTRACT NUMBER FA8650-10-C-2105	
				5b. GRANT NUMBER	
				5c. PROGRAM ELEMENT NUMBER 62203F	
6. AUTHOR(S) Mike Willett (Orbital Research, Inc./Linear Dimension, Inc.) Alireza R. Behbahani (AFRL/RQTE)				5d. PROJECT NUMBER 3005	
				5e. TASK NUMBER N/A	
				5f. WORK UNIT NUMBER Q0GZ	
7. PERFORMING ORGANIZATION NAME(S) AND ADDRESS(ES) Orbital Research, Inc./ Linear Dimension, Inc. 4415 Euclid Avenue, Suite 500 Cleveland, OH 44103-3733				8. PERFORMING ORGANIZATION REPORT NUMBER	
Engine Systems Branch (AFRL/RQTE) Turbine Engine Division Air Force Research Laboratory, Aerospace Systems Directorate Wright-Patterson Air Force Base, OH 45433-7542 Air Force Materiel Command, United States Air Force					
9. SPONSORING/MONITORING AGENCY NAME(S) AND ADDRESS(ES) Air Force Research Laboratory Aerospace Systems Directorate Wright-Patterson Air Force Base, OH 45433-7542 Air Force Materiel Command United States Air Force				10. SPONSORING/MONITORING AGENCY ACRONYM(S) AFRL/RQTE	
				11. SPONSORING/MONITORING AGENCY REPORT NUMBER(S) AFRL-RQ-WP-TP-2013-0210	
12. DISTRIBUTION/AVAILABILITY STATEMENT Approved for public release; distribution unlimited.					
13. SUPPLEMENTARY NOTES PA Case Number: 88ABW-2013-2325; Clearance Date: 13 May 2013. This paper contains color. The conference paper was presented at the 59th International Instrumentation Symposium and MFPT 2013 Joint Conference, held in Cleveland, Ohio on May 13 through May 17, 2013. © 2013 ISA. The U.S. Government is joint author of the work and has the right to use, modify, reproduce, release, perform, display, or disclose the work.					
14. ABSTRACT Control systems can vary from small and simplex to large and complex, but in all cases the systems consist of a controller, at least one actuator (as simple as a solenoid) and enough sensors to determine the result of the actuation, or in other words, the state of the system. In many cases, the size of the system, meaning either the physical size of the components, or the distance separating the sensors from the controller, presents problems in wiring, noise immunity, and power distribution. By configuring the control system to use distributed smart nodes, these problems are mitigated to various degrees determined by the requirements of the system and the amount by which control can feasibly be distributed.					
15. SUBJECT TERMS smart node, architecture					
16. SECURITY CLASSIFICATION OF:			17. LIMITATION OF ABSTRACT: SAR	18. NUMBER OF PAGES 32	19a. NAME OF RESPONSIBLE PERSON (Monitor) Alireza R. Behbahani 19b. TELEPHONE NUMBER (Include Area Code) N/A
a. REPORT Unclassified	b. ABSTRACT Unclassified	c. THIS PAGE Unclassified			

STANDARDIZED FAULT-TOLERANT SENSING NODES FOR AN INTELLIGENT TURBINE ENGINE CONTROL SYSTEM

*Mike Willett, and Alireza Behbahani
Orbital Research Inc. and Air Force Research Laboratory*

Key words: distributed engine control, high temperature electronics, digital networks, Fault-tolerant Sensing

Abstract: Control Systems can vary from small and simplex to large and complex, but in all cases the systems consist of a controller, at least one actuator (as simple as a solenoid) and enough sensors to determine the result of the actuation, or in other words, the state of the system. In many cases the size of the system, meaning either the physical size of the components, or the distance separating the sensors from the controller, presents problems in wiring, noise immunity, and power distribution. By configuring the control system to use distributed “smart” nodes, these problems are mitigated to various degrees determined by the requirements of the system and the amount by which control can feasibly be distributed.

I. System Architecture

Centralized Architecture. The following **Figure 1** shows a representation of a centralized control system on a turbine engine. All actuators and sensors are point-to-point cabled to the controller (FADEC) which houses electronics to interface to each node in the system. The electronics are cooled to remove the heat of the engine and heat generated by the electronics themselves.

Each function resides within the FADEC and uses Unique Point-to-Point Analog Connections to System Effectors and Sensors

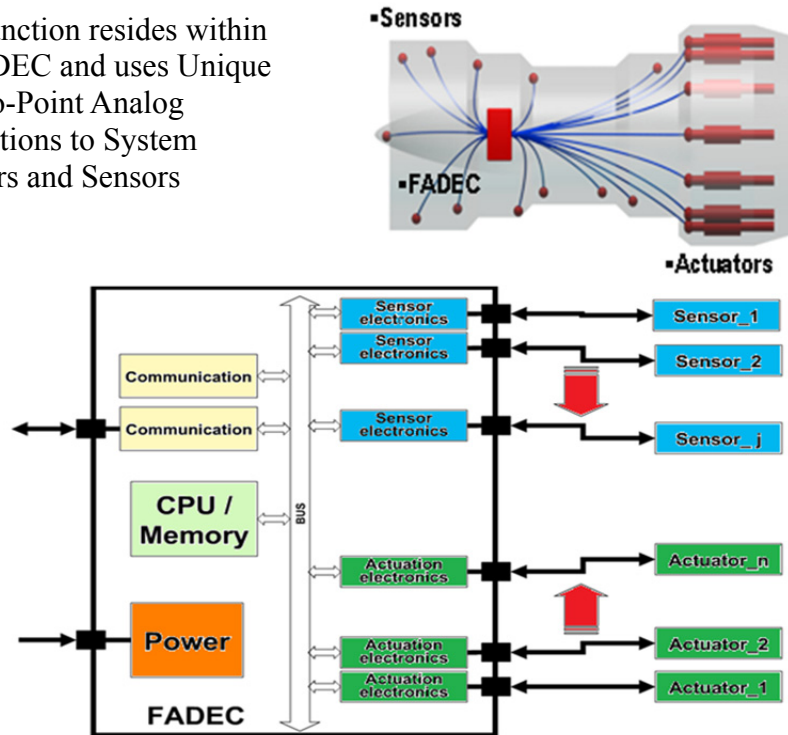

Figure 1: Centralized Control System

Distributed Architecture. In contrast, **Figure 2** shows a representation of a distributed control system on the same turbine engine. The actuators and sensors interface to Smart Nodes which, in turn communicate to the FADEC via a digital communication bus.

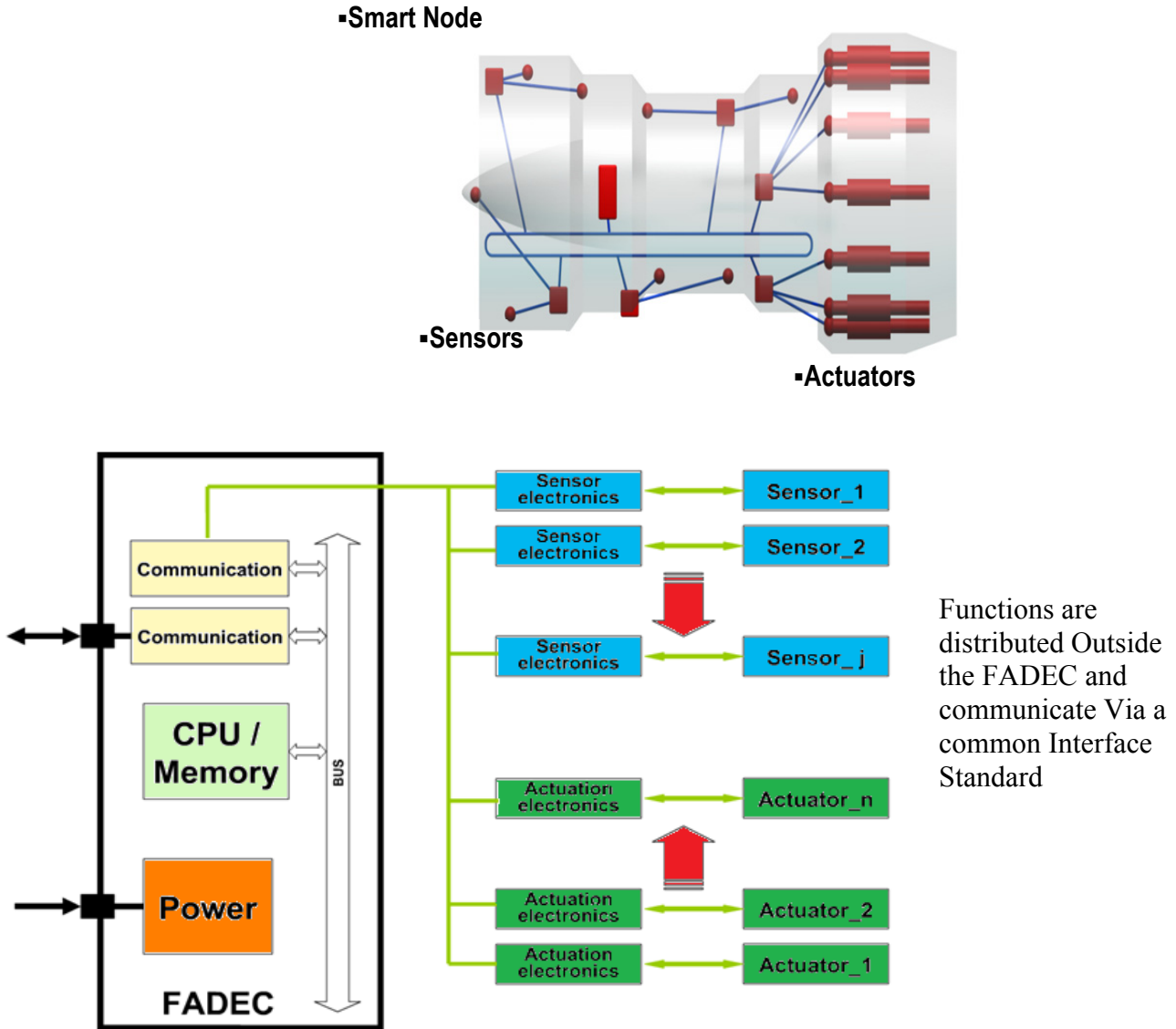
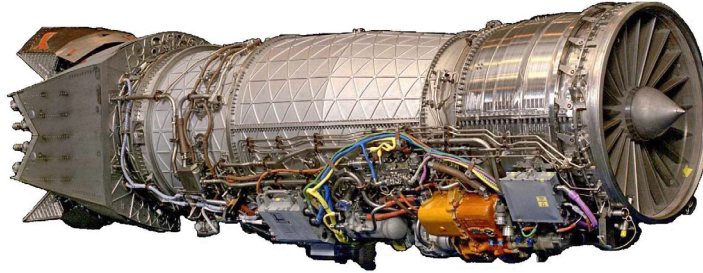

Figure 2: Distributed Control System

How is Distributed Control Different? Both of these system architectures may achieve the required robust control of the turbine engine. However, the distributed control scheme may provide some desired improvements:

Analog signal lines are significantly shortened improving S/N ratio. **Figure 3** shows the large distances that some analog signal bundles must traverse to connect to an interface.



Engine Controls and Accessories Comprise a Substantial Portion of Total Engine Weight as Shown in This Core-Mounted Fuel-Cooled Military Control Implementation

*(Courtesy of Pratt & Whitney)

Figure 3: Turbine Engine Showing Controls

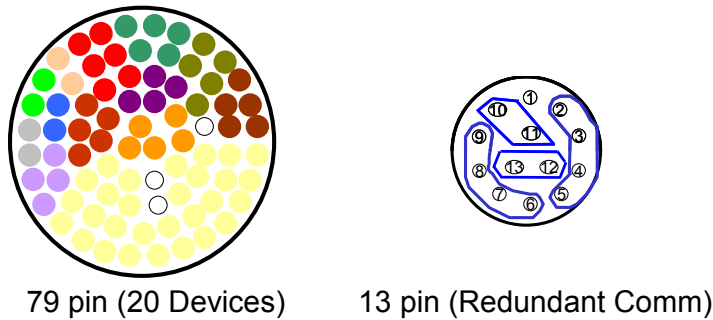

Figure 5: Cable Bundle from Typical FADEC and Replacement

Cabling is greatly reduced. **Figure 5** shows two typical examples of a cable bundle controlling 20 devices in the existing FADECs today (central). The one on the left contains 76 connections. The one on the right contains 13 connections of digital communication.

FADEC cooling is reduced (or eliminated). By removing interface circuitry from the FADEC, the power dissipation is reduced, and by connecting by digital data bus, the FADEC can be moved to a less hostile environment; it no longer needs to be as close as possible to the effectors it controls. **Figure 6** shows a temperature profile of a typical turbine engine. It can be seen that areas in the combustion and exhaust are too hot for even high temperature electronics. Liang-Yu Chen, Beheim, G, and others (see references at the end) have shown that high temperature wireless sensing and data transmission system including packaging technology, and SiC electronic devices can be deployed for those applications. In these cases, sensors and actuators will be controlled from smart nodes that are either cooled, or positioned farther away than normal.

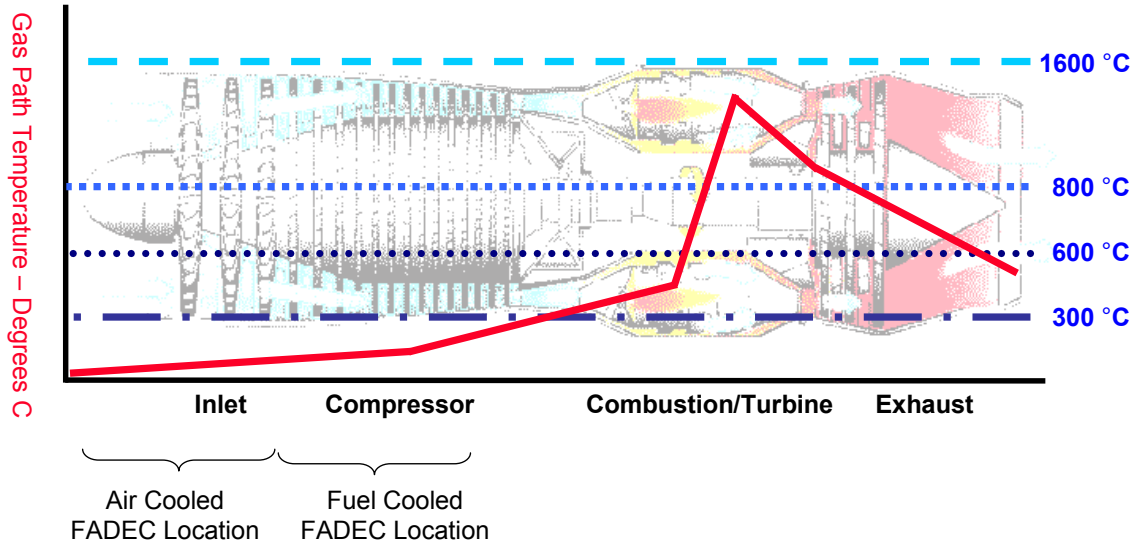

Figure 6: Temperature Profile of Typical Turbine Engine

Additional Advantages. Fault detection and isolation is improved. For example, when a thermocouple is malfunctioning, the problem could be in the thermocouple itself, in the cable connection to the FADEC control, or in the interface itself. The current maintenance procedure is to replace everything at once. If the thermocouple interface is distributed, then the faulty module can be replaced without replacing any other components in the process.

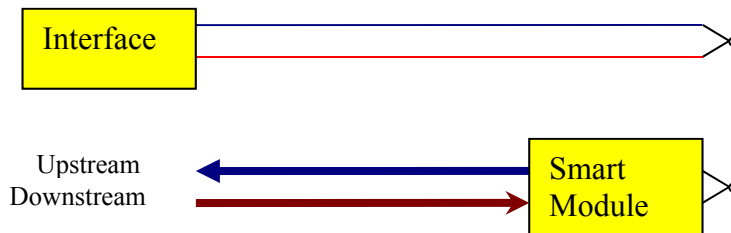

Figure 7: Sensors versus “smart sensors”

This Modularity provides for easy replacement of defects when they are found. This Modularity simplifies upgrades for new sensors, system reconfiguration, etc. as they are implemented.

The Smart System maintenance is streamlined (cost reduced) by enabling prognostic health management (i.e. predicting useful end-of-life)

Smart Node attributes. The Smart Node must have the following minimum attributes:

It must have an **extended temperature operating range**. (SOI electronics can operate up to 225°C.)
 It must be rugged enough to survive in the hostile engine environment.

It must be **low cost**. Even though high temperature components are more expensive, the smart node cannot exceed reasonable cost targets. Cost tradeoffs must be considered. By incorporating prognostic health in distributed nodes, millions of dollars can be saved in maintenance. Not only can the distributed nodes be serviced by less technical personnel, but also, expensive dismantling of engines and shipping to regional engine services centers for overhaul can be minimized.

It must have a **communication protocol interface**. The digital bus must be rugged, reliable, fault tolerant, and high enough in bandwidth to accommodate the interfaces of several effectors. In Figure 8 a preliminary estimate is made for an asynchronous protocol with the given characteristics.

It must have **enough intelligence** to meet the needs of the system. How much is enough? Every smart node needs **A/D conversion**. Some would like to off load Controller computations by having the smart node perform digital signal processing (**DSP**) **functions** – such as converting the analog voltage to a temperature (or pressure, or position etc.). Any electronic interface must have **fault detection and isolation** built in. And some smart nodes could provide **useful end-of-life estimations** for maintenance cost reductions.

Traffic Approximations – Necessary Bandwidth

- Multi-Drop Should be Supported to Allow Cable Reduction
- Indicates a 1MHz Bus is Required for an 8 DCM per Multi-Drop Bus
- Bus Speed Can Increased By Designer for Greater Bandwidth

Assume two command/response per DCM	
2	messages per DCM per minor frame
18	bytes send per message
18	bytes receive per message
250	microsecond lag between cmd/resp
<hr/>	
1	Mhz Bus Freq
1	us per bit
<hr/>	
1076	microseconds per DCM
8	# of DCMs in the multi-drop
8.608	milliseconds of comm time
10-17	milliseconds minor frame in typical Commercial minor frame

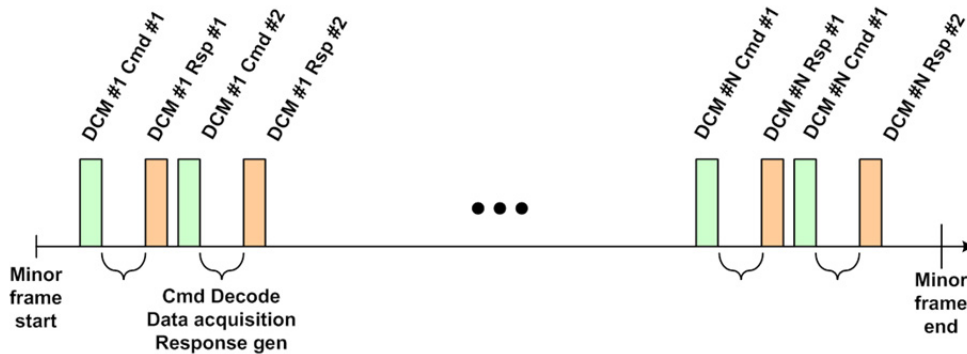

Figure 8: Number of Nodes per Network

II. Smart Nodes

Figure 8 shows a block diagram of a smart node.

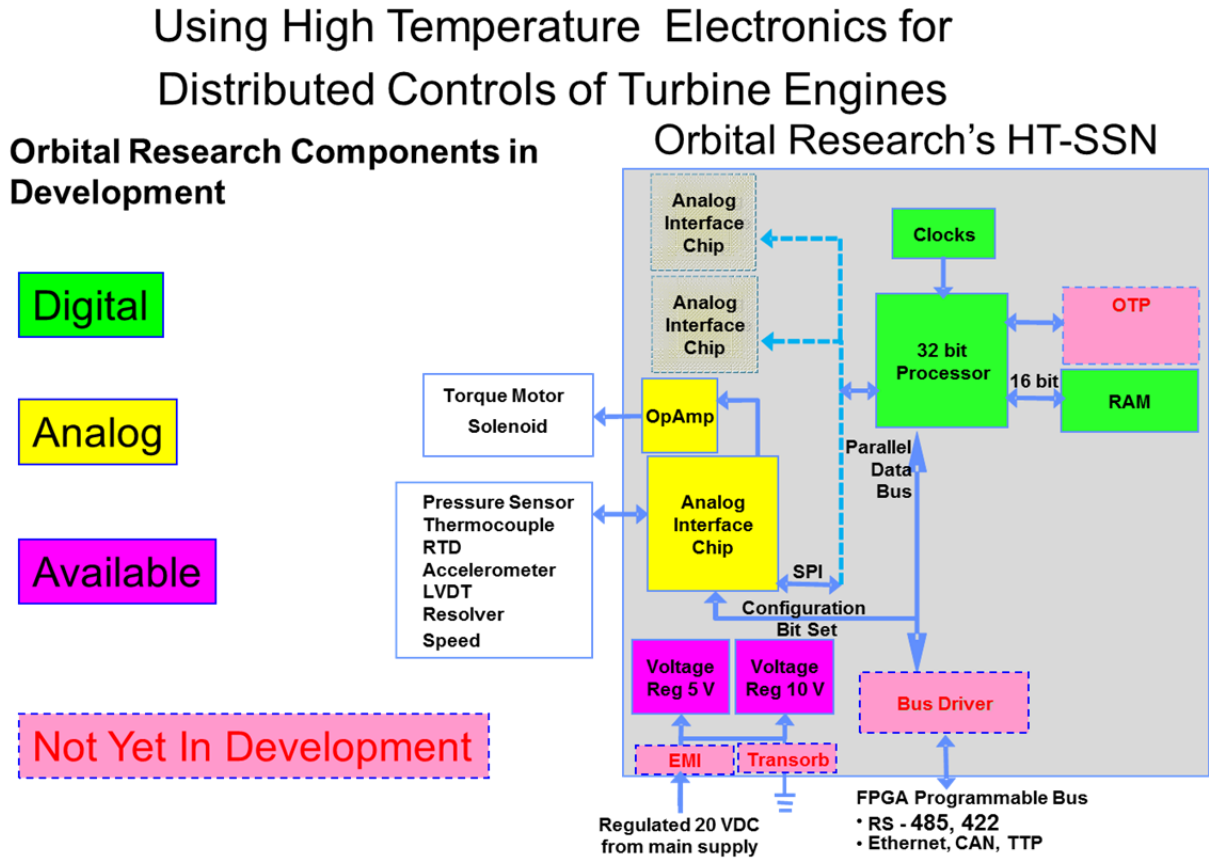

Figure 9: Smart Sensing Node

The main sections are analog (interface to sensors and drivers for actuators), digital (DSP, Communication, Diagnostics, Prognostics, sensor calibration, etc.), power regulation, and noise suppression.

III. Standardization

Since high temperature electronics are custom designed and fabricated ASICs, it becomes imperative that smart node standards be instituted and widely accepted in order to keep development and per piece costs to a minimum. This includes not only minimum hardware features, but also such things as protocol standards, operating temperature conditions and other

hostile environment survivability requirements. To date, there are two IEEE standards that apply to smart nodes. They are:

IEEE 1451.0 “Standard for Smart Transducer for sensors and Actuators – Common Functions, Communication Protocols, and Transducer Electronic Data Sheet (TEDS) Format.”

IEEE 1451.3 “Standard for a Smart Transducer Interface for Sensors and Actuators – Digital Communication and TEDS Formats for Distributed Multidrop Systems.
DECWG_Node_Level_Req_Spec_Final-HoneywellProprietary.doc

In order to keep costs down it is imperative that the high temperature hardware be as generic as possible. What that means is that there should be one set of electronic components designed to interface to or be programmed for a wide variety of sensors and actuator interfaces.

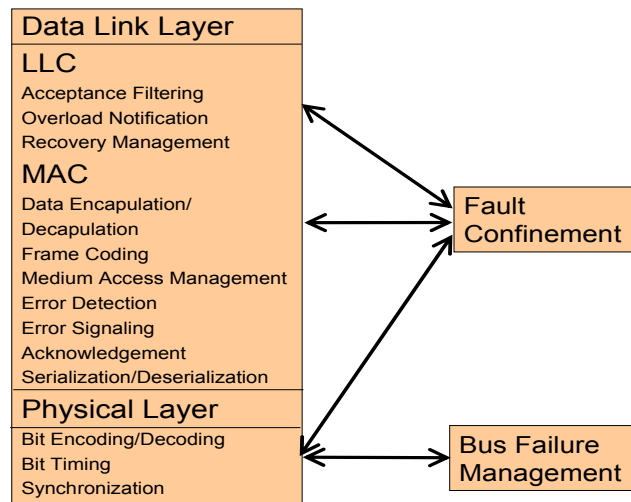

Figure 10: Protocol Layers Involved In Fault Detection

IV. Fault Tolerance

Fault Detection can be localized at a given smart node. Data bus fault detection, however is a more complicated process. Figure 8 shows a system level approach to fault detection on a digital data bus.

Redundancy (Alternate paths) should be built into the design of the network. Each system needs a fail-safe backup. **Figure 11** shows how this redundancy could be implemented in a communication bus environment.

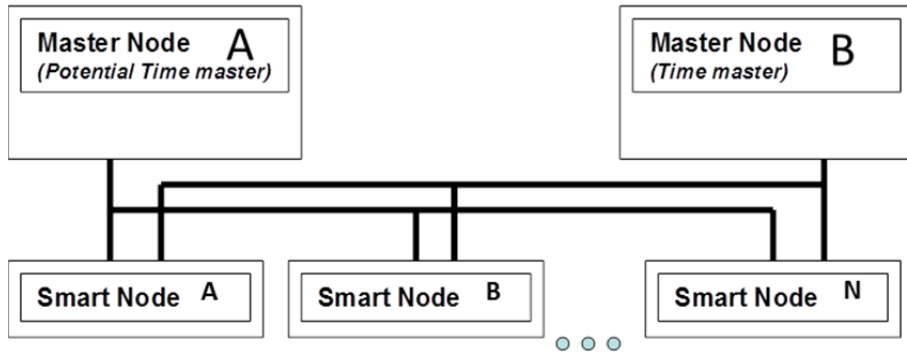

Figure 11: Multi-Smart Nodes Redundancy Management

The system should be **fail-safe**, to some extent. Digital bus drivers require a monitor of their output to disconnect when fault conditions are detected. No Smart Node can seize the communication line or flood the channel with spurious signals.

V. Prognostics

Prognostics is the reporting of sensors or actuators that are nearing the end of their useful life. The purpose of Prognostic Health Management is to repair systems before they fail, while maximizing useful life consumption, and to have the necessary parts, tools and maintainers waiting nearby to resolve the correct problem as quickly and efficiently as possible. This is estimated from a combination of tabulated usage hours, increased frequency of erroneous readings, or faulty actuation, and *a priori* knowledge of the possible failure modes of a given node.

Memory Storage Requirement. Depending on the type of mechanism, and the bandwidth of the data being monitored for its health, a significant amount of data storage may be required.

VI. Integration of Intelligent Sensor Network

Figure 12 shows a hierarchical system network of an aircraft turbine engine. The Distributed Intelligent Nodes provide real time sensor and actuator data to supervisory programs that can perform the required functions in a stable and reliable manner.

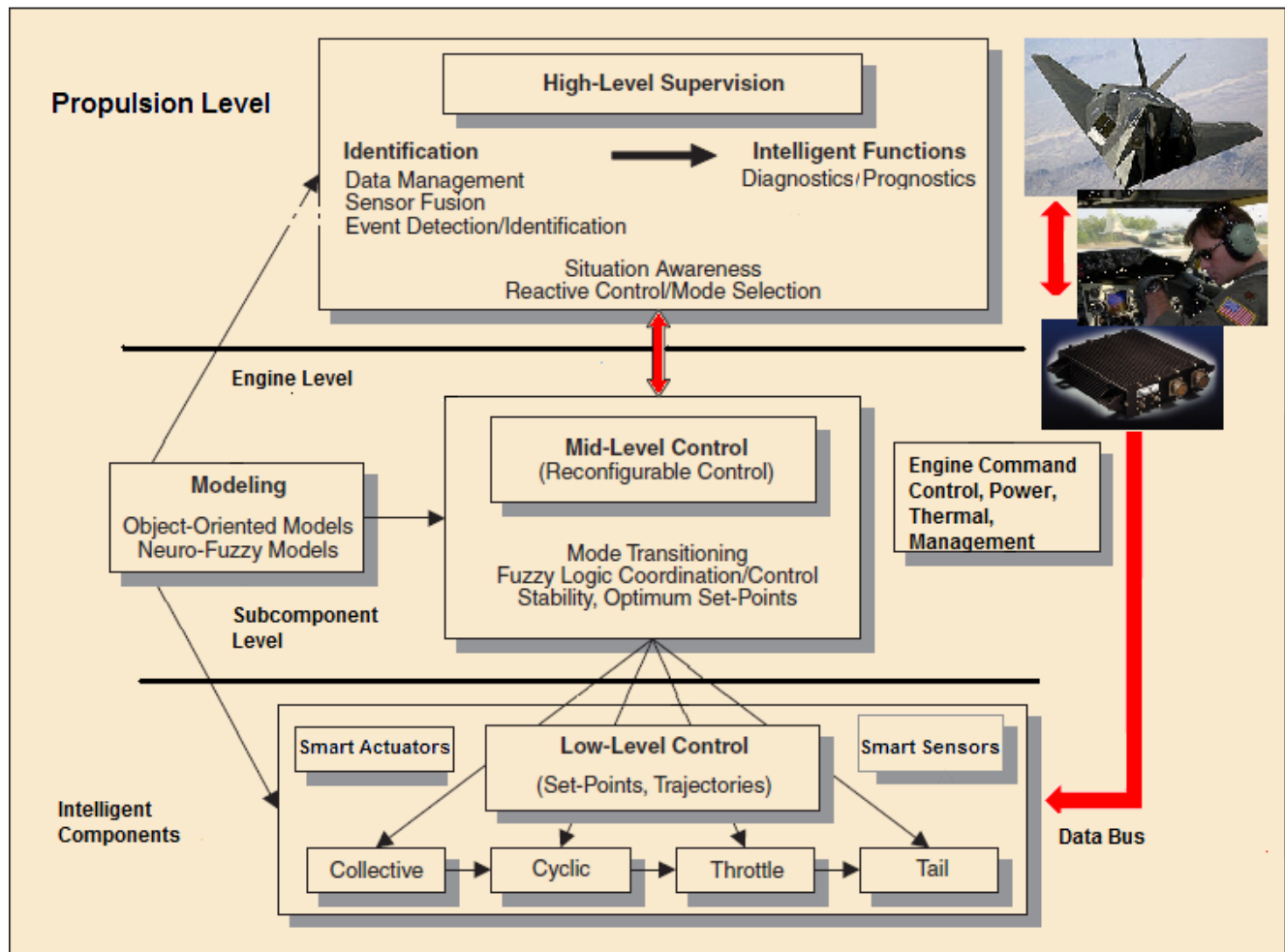

Figure 12: Hierarchical Reconfigurable Distributed Control Architecture

VII. Implementation

Implementation of Smart Nodes for Distributed Control has some challenges to overcome. High temperature electronics must be created that are generic, rugged, cost effective and reliable. Each high temperature component is designed as an application specific integrated circuit (ASIC). The application specific to any given IC must be adaptable to a large number of design requirements, because the development costs of any ASIC is large, and the cost of components can be reduced only by increasing volumes.

The next challenge is therefore to collaborate with manufacturers to standardize the specific components needed for each of their distributed control system designs. This effort is being addressed by a consortium of manufacturers, military and government agencies

And finally, the components themselves must be qualified, verified, and second-sourced in order to be placed on any manufacturers' Approved Vendor List. No component can go on any engine unless it is listed on a manufacturers' AVL.

Conclusion

Control of turbine engine systems can be greatly enhanced by incorporating distributed control of sensors and actuators. The necessary parts to enable introduction of this type of system architecture are ruggedized high temperature ASICs. By careful and prudent design, these ASICs can be standardized and generic to allow application to a wide variety of control structures. The advantages of distributed processing have been shown to be increased noise immunity; ease of sensor calibration; fault tolerance and fault detection, isolation, and recovery; as well as prognostic capabilities.

References

Ihara, H., Mori, K., "Autonomous decentralized computer control systems," Computer (IEEE), Vol. 17, No. 8, pp. 57-66, Aug. 1984.

Douglas Jensen, Distributed Control, Distributed Systems - Architecture and Implementation, An Advanced Course, p.175-190, January 1981

K. H. Kim, Evolution of a Virtual Machine Supporting Fault-Tolerant Distributed Processes at a Research Laboratory, Proceedings of the First International Conference on Data Engineering, p.620-628, April 24-27, 1984

Leslie Lamport , Robert Shostak , Marshall Pease, The Byzantine Generals Problem, ACM Transactions on Programming Languages and Systems (TOPLAS), v.4 n.3, p.382-401, July 1982 [doi>10.1145/357172.357176]

Kinji Mori , Hirokazu Ihara , Katsumi Kawano , Minoru Koizumi , Masayuki Orimo , Kozo Nakai , Hiroaki Nakanishi , Yasuo Suzuki, Autonomous decentralized software structure and its application, Proceedings of 1986 ACM Fall joint computer conference, p.1056-1063, November 1986, Dallas, Texas, United States

Randell, B., "System structure for software fault tolerance," IEEE Trans. Softw. Enll., Vol. SE-1, No. 2, pp. 220-232, June 1975.

Richard D. Schlichting , Fred B. Schneider, Fail-stop processors: an approach to designing fault-tolerant computing systems, ACM Transactions on Computer Systems (TOCS), v.1 n.3, p.222-238, August 1983 [doi>10.1145/357369.357371]

Andy Berner & Doug Williams, "Challenges for Data Bus Structures in Distributed Engine Controls" BAE TETS presentation 2010, slides 4 and 5.

Beheim, G., Ned, A.A., Masheeb, F., Kurtz, A.D., and Wolff, J.M. (2001) "Dynamic Pressure Measurements Using Silicon Carbide Transducers," *19th International Congress on Instrumentation in Aerospace Simulation Facilities (ICIASF '01)*, Cleveland, Ohio, August 27-30, 2001.

Liang-Yu Chen, "Body of Knowledge (BOK) of Applications of High Temperature Wireless Data Transmission Systems in Aerospace Engine Technology", Ohio Aerospace Institute/NASA Glenn Research Center, For NEPP Program August 2005.

Beheim, G.M. and Evans, L. (2004) "Deep Reactive Ion Etching for Bulk Micromachining of Silicon Carbide," in *the CRC MEMS Handbook*, CRC Press, Boca Raton, LA.

Chen, L.-Y., Hunter, G.W., and Neudeck, P.G. (2000) "Silicon Carbide Die attach Scheme for 500°C Operation," in *Proceedings of MRS 2000 Spring Meeting – Wide Bandgap Electronics Devices (Symp. T)*, April 10-14, San Francisco, CA.
Chen, L.-Y. and Lei, J.-F. (2004) "Packaging of Harsh-Environment MEMS Devices," in *the MEMS Handbook*, August, CRC Press, Boca Raton.

Hunter, G.W., Neudeck, P., Thomas, V., Chen, L., Liu, C.C., Ward, B., Wu, Q.H., Makel, D., Dutta, P., Frank, M., Trimbol, J., Fulkerson, M., and Patton, B. (2002) "Development of Chemical Sensor Arrays for Harsh Environments and Aerospace Applications," in *Proceedings of IEEE Sensors 2002*, June 12-14, Orlando, FL.

Hunter, G.W., Liu, C.C., and Makel, D.B. (2004) "Microfabricated Chemical Sensors for Aerospace Applications," Chapter 27, *the CRC MEMS Handbook*, CRC Press, Boca Raton, LA.

Hunter, G.W., Neudeck, P.G., Xu, J., Lukco, D., Trunek, A., Artale, M., Lampard, P., Androjna, D., Makel, D., Ward, B., and Liu, C.C. (2004) "Development of SiC -based Gas

Setting the Standard for Automation™



16 May 2013

Instrumentation - Aerospace Applications

Intelligent Turbine Engine Controls

Session E4 - Roxy

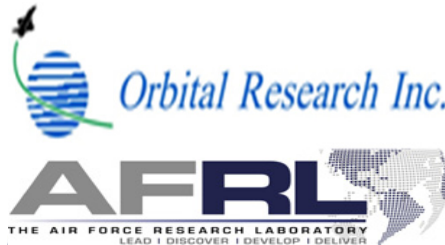

Standardized Fault-tolerant Sensing Nodes for an Intelligent Turbine Engine Control System

Mike Willett

Alireza R. Behbahani, Ph.D.

Orbital Research and Air Force Research Laboratory

Standards

Certification

Education & Training

Publishing

Conferences & Exhibits

59th International Instrumentation, Symposium – Cleveland, OH

Control Systems can vary from small and simplex to large and complex, but in all cases the systems consist of a controller, at least one actuator (as simple as a solenoid) and enough sensors to determine the result of the actuation, or in other words, the state of the system. In many cases the size of the system, meaning either the physical size of the components, or the distance separating the sensors from the controller, presents problems in wiring, noise immunity, and power distribution. By configuring the control system to use distributed “smart” nodes, these problems are mitigated to various degrees determined by the requirements of the system and the amount by which control can feasibly be distributed

Presenter Mike Willett

- Project Engineer: Micro Devices
- Last 8 years spent in developing high temperature ICs and Control Modules
- Experience in COB and Flip Chip miniaturization
- 30 year career in circuit design and pcb layout





Centralized Control System

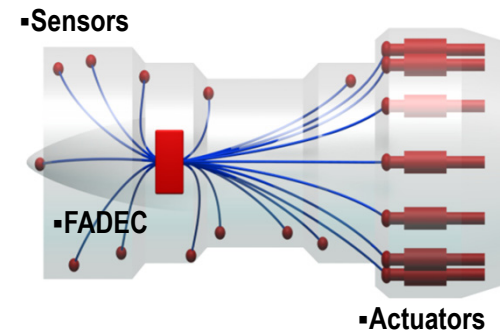
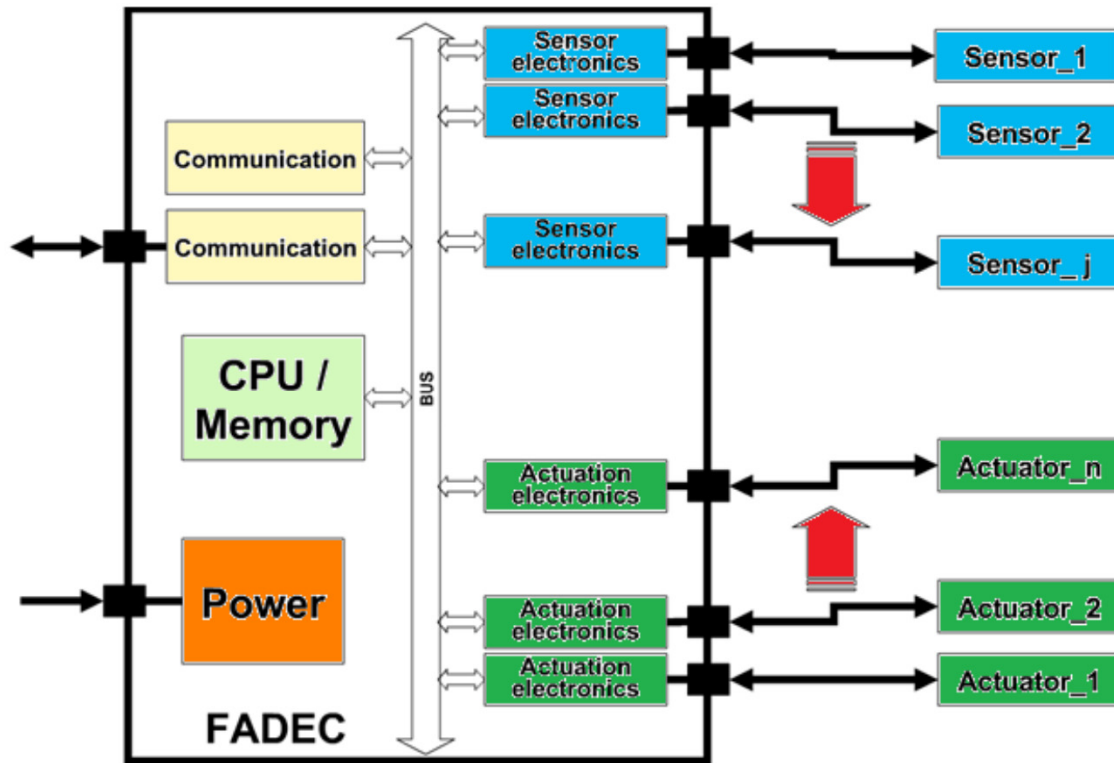

Each function resides within the FADEC and uses unique Point-to-Point analog connections to System Effectors

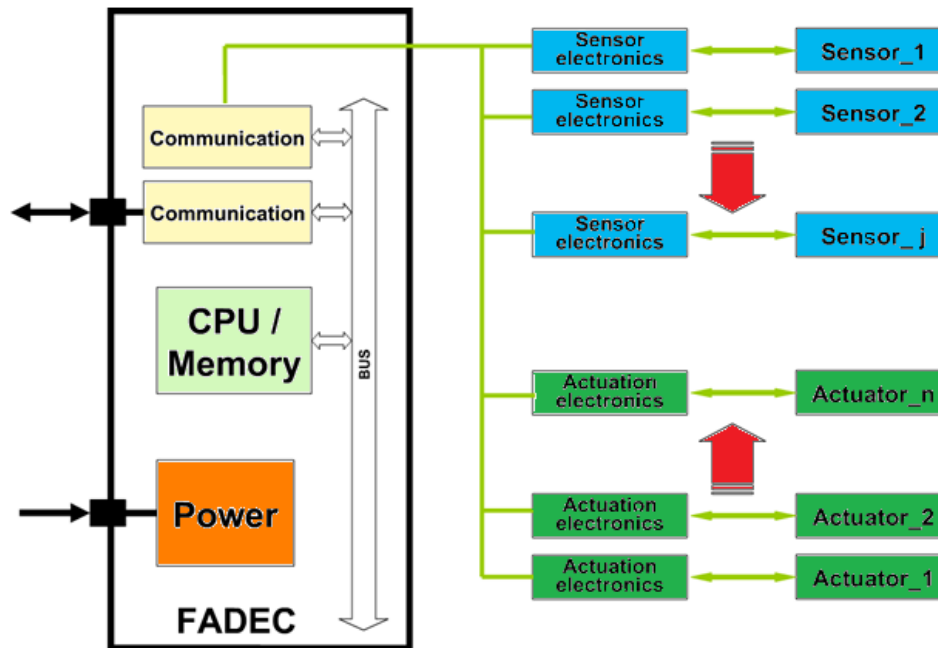

Functions are distributed outside the FADEC and are communicated via a common Interface Standard

Turbine Engine Showing Controls

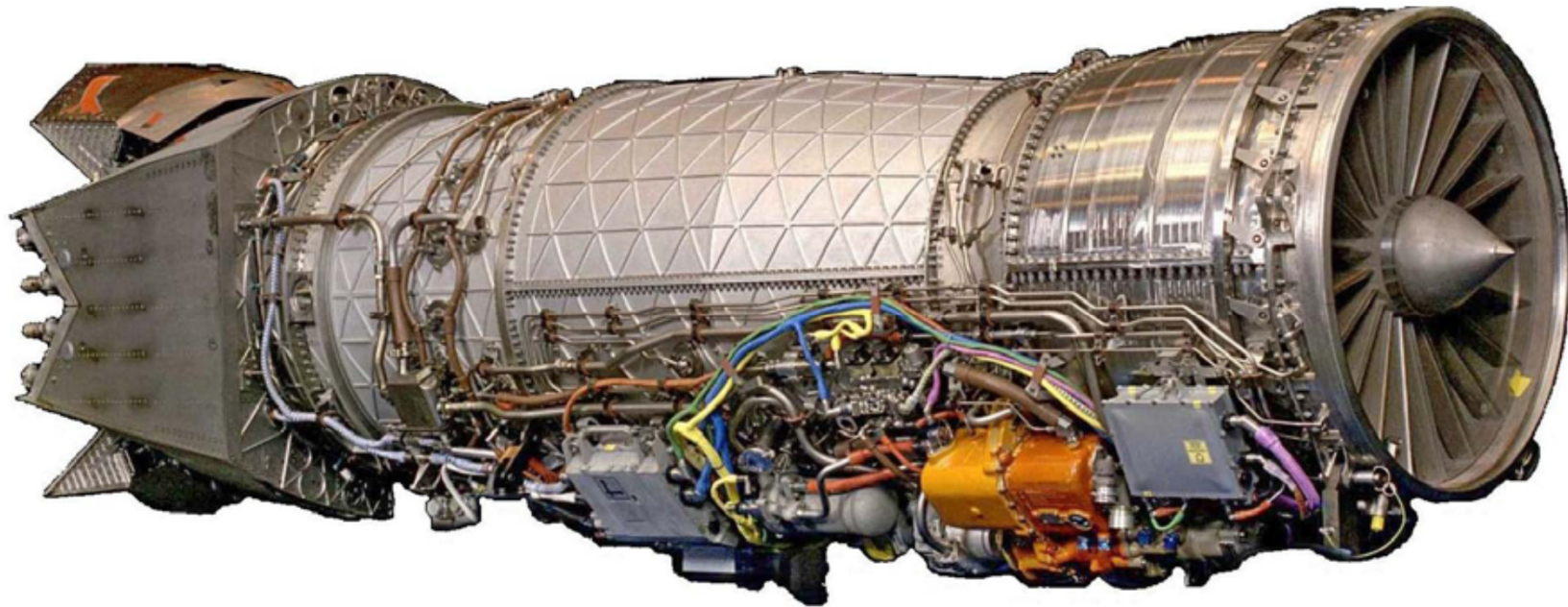

Engine Controls and Accessories Comprise a Substantial Portion of Total Engine Weight as Shown in This Core-Mounted Fuel-Cooled Military Control Implementation
(Courtesy of Pratt & Whitney)

Cable Bundle from Typical FADEC and Replacement

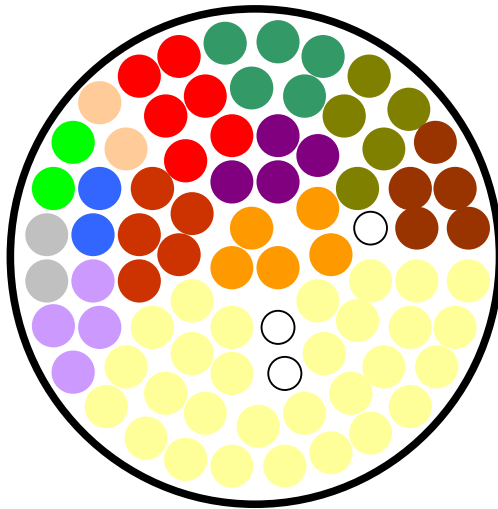

79 pin (20 Devices)

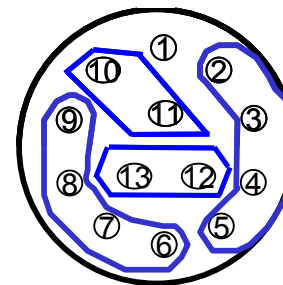

13 pin (Redundant Comm)

Temperature Profile of Typical Turbine Engine

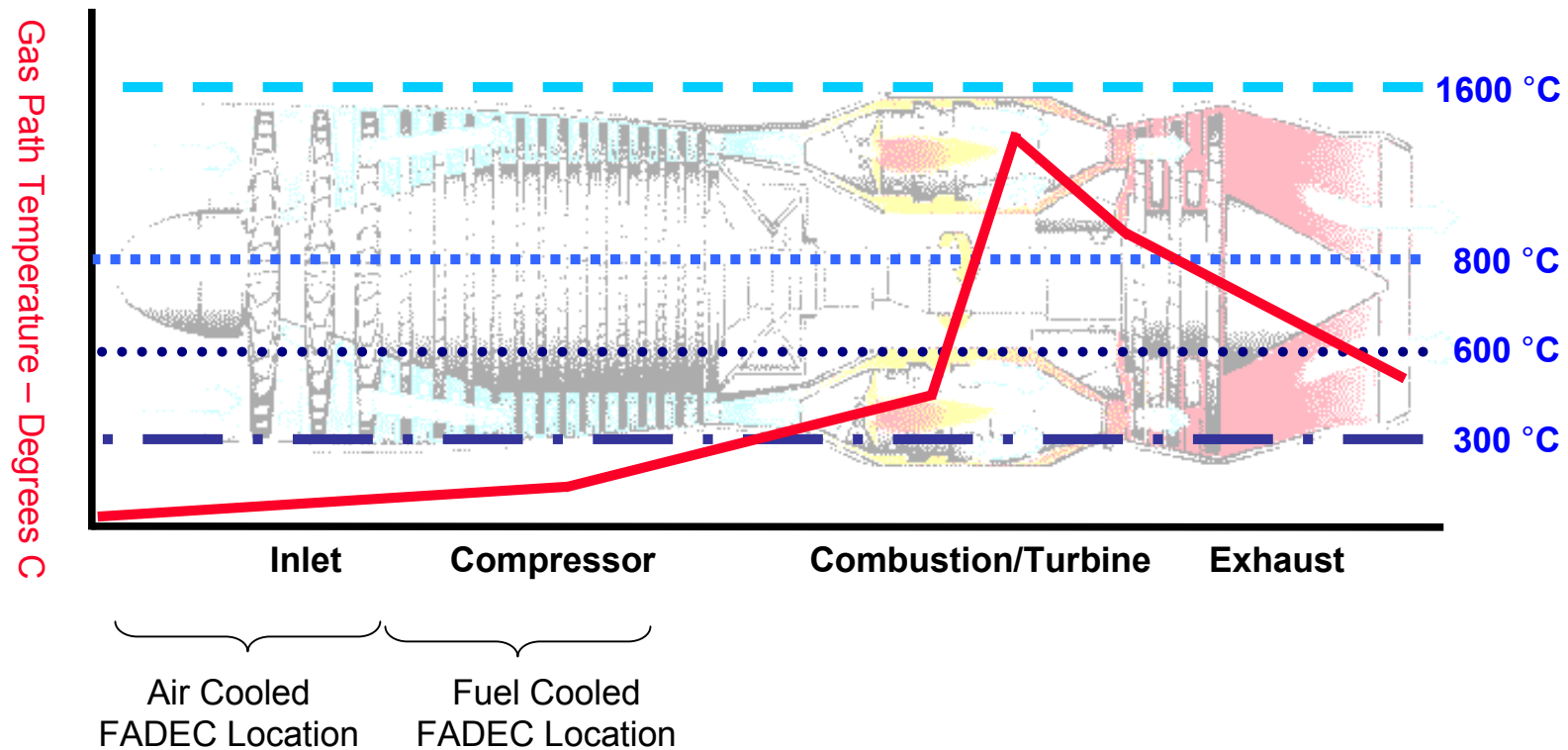

Modularity for Streamlined Maintenance

Where is the failure located?

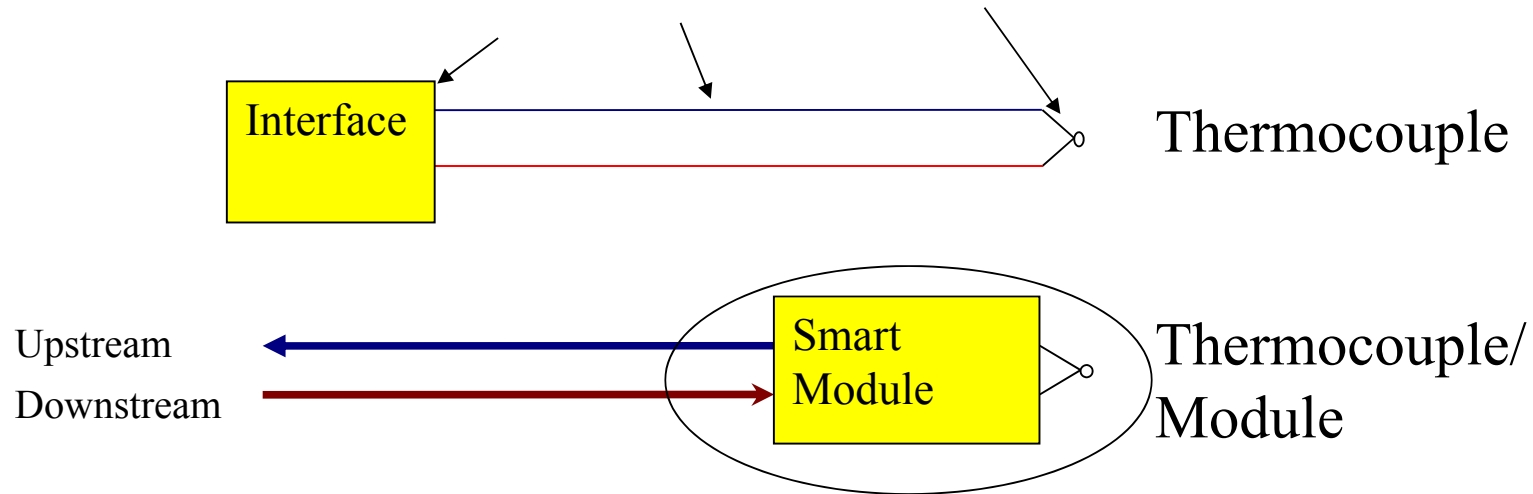

What Happens When a Thermocouple Fails?

Traffic Approximations – Necessary Bandwidth

BAE SYSTEMS

Assume two command/response per DCM	
2	messages per DCM per minor frame
18	bytes sent per message
18	bytes received per message
250	µs lag between cmd/resp
1	Mhz Bus Freq
1	µs per bit
1076	µs per DCM
8	# of DCMs in the multi-drop
8.608	ms of comm time
10-17	ms per typical minor frame

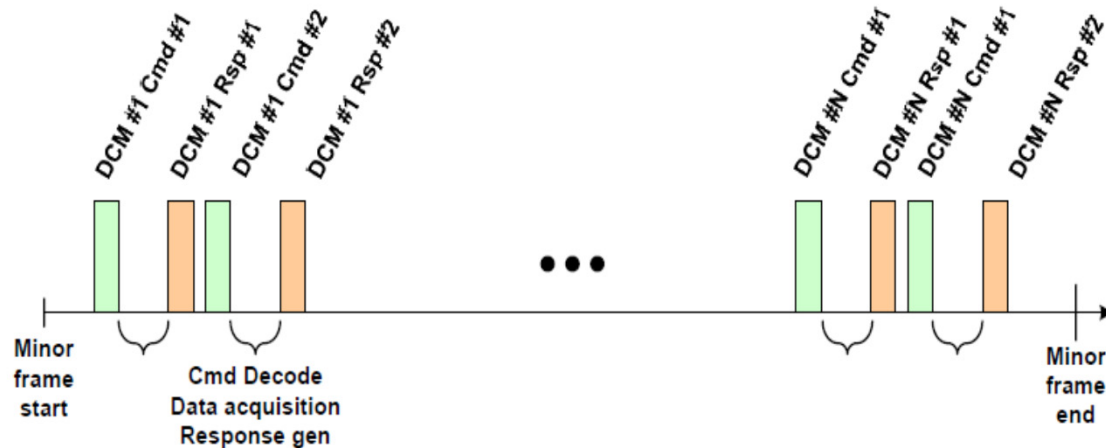

Orbital Research Components in Development

Digital

Analog

Available

Now In Development

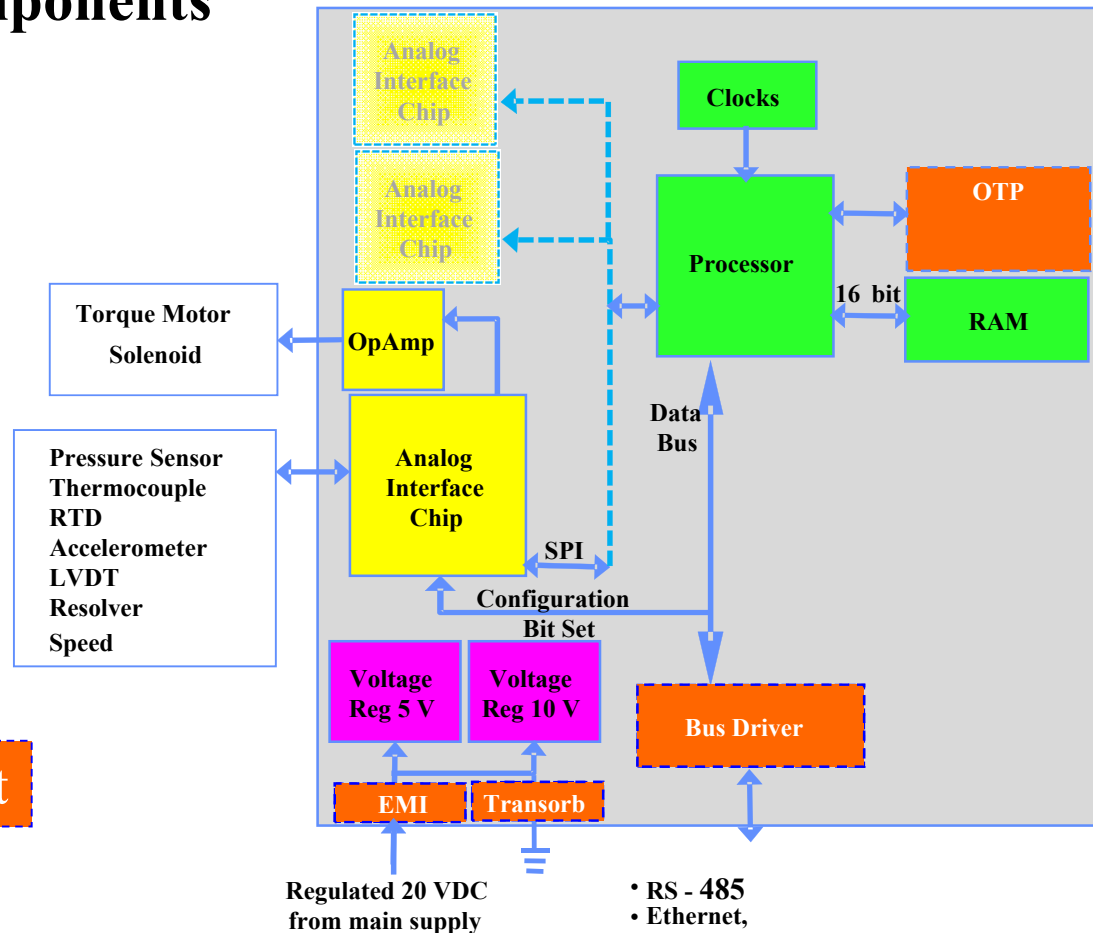

Orbital Research's HT-SSN

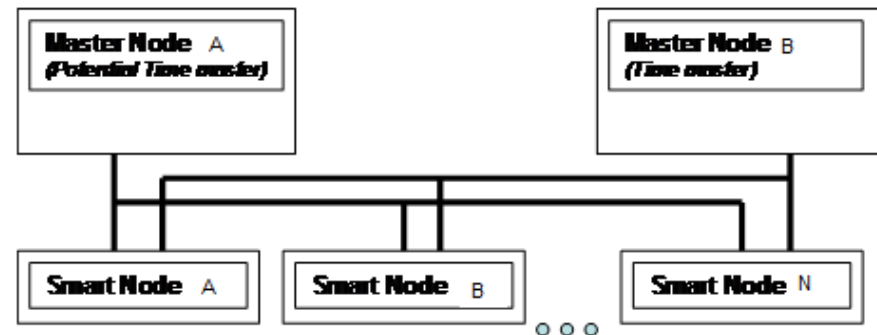
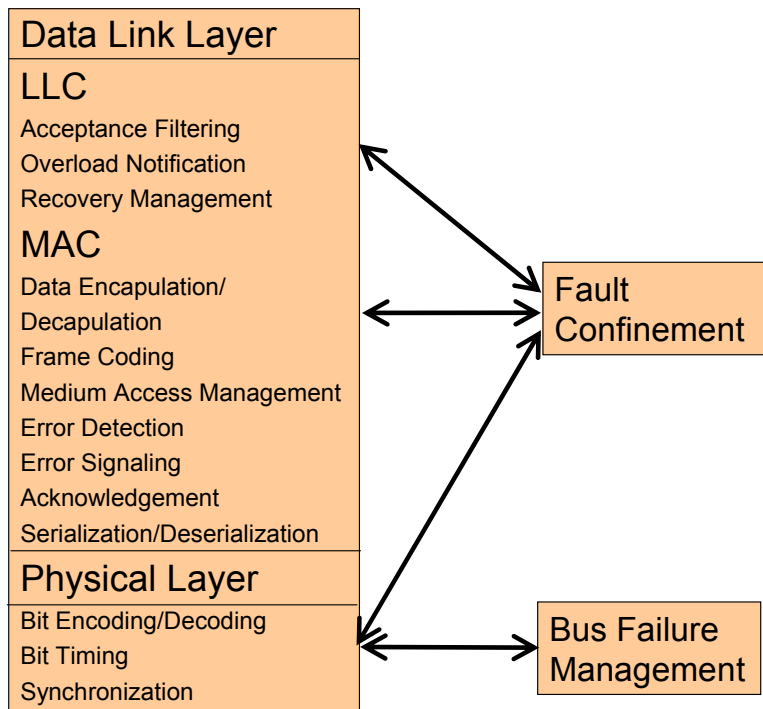

Multi-Smart Nodes Redundancy Management

Protocol Layers Involved In Fault Detection

Integration of Intelligent Sensor Network

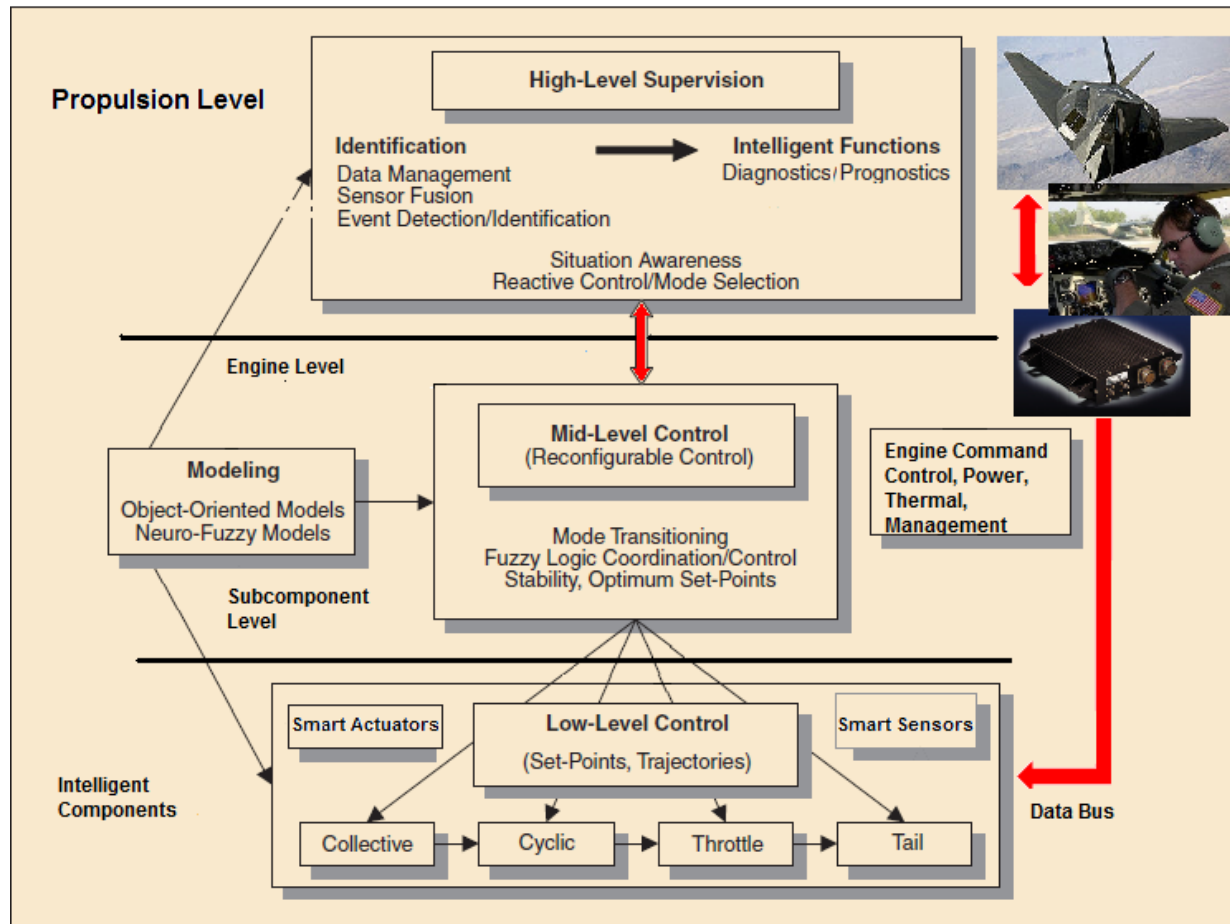

- Challenges to Overcome
 - Generic
 - Rugged
 - Cost Effective
 - Reliable
- Each High Temperature Component is an ASIC
 - Development costs are high
 - Standards in the process of being defined by DECWG
 - Need Qualification and Verification
 - Each Component must have a 2nd Source

- Distributed Control provides added benefits
 - Increase Noise Immunity
 - Sensor Calibration Made Easy
 - Fault Detection and Isolation
 - Fault Tolerance
 - Prognostic Functions Can be Implemented
 - Weight Reduction

- Requires ruggedized high temperature ASICs
 - Standardized
 - Generic
 - 2nd Sourced