

CLEARANCE REQUEST FOR PUBLIC RELEASE OF DEPARTMENT OF DEFENSE INFORMATION

(See Instructions on back.)

(This form is to be used in requesting review and clearance of DoD information proposed for public release in accordance with DoDD 5230.09.)

TO: (See Note) Chief, Office of Security Review, 1155 Defense Pentagon, Washington, DC 20301-1155

Note: Regular mail address shown above. For drop-off/next day delivery, use:
Room 12047, 1777 North Kent Street, Rosslyn, VA 22209-2133

1. DOCUMENT DESCRIPTION

a. TYPE Study/Manuscript	b. TITLE A critical analysis of the U.S. Marine Corps 04XX logistics community.
c. PAGE COUNT 221	d. SUBJECT AREA An examination of the training and readiness of a specific military occupational field.

2. AUTHOR/SPEAKER

a. NAME (Last, First, Middle Initial) Lathers, John, D.	b. RANK GS-12	c. TITLE Instructional Systems/Training Specialist
d. OFFICE Marine Corps Combat Service Support Schools		e. AGENCY DoD, DoN, USMC, TECOM, Ground Training Branch

3. PRESENTATION/PUBLICATION DATA (Date, Place, Event)

Submitted to higher headquarters for information purposes on 2 May 2013. This request is made prior to submission to the Defense Technical Information Center (DTIC).

**CLEARED
For Open Publication**

AUG 6 2013 4

4. POINT OF CONTACT

a. NAME (Last, First, Middle Initial) Lathers, John, D.	Office of Security Review Department of Defense	b. TELEPHONE NO. (Include Area Code) 910.450.1849
---	--	---

5. PRIOR COORDINATION

a. NAME (Last, First, Middle Initial) None.	b. OFFICE/AGENCY	c. TELEPHONE NO. (Include Area Code)
---	------------------	--------------------------------------

6. REMARKS

The author - a DoD civil service employee - acted in a private capacity and not in connection with their official duties - prepared the study/manuscript for information purposes. The information provided within the document meets or exceeds ethical standards referenced in DoDD 5500.07 and security standards referenced in DoDD 5205.02E.

7. RECOMMENDATION OF SUBMITTING OFFICE/AGENCY

a. THE ATTACHED MATERIAL HAS DEPARTMENT/OFFICE/AGENCY APPROVAL FOR PUBLIC RELEASE (qualifications, if any, are indicated in Remarks section) AND CLEARANCE FOR OPEN PUBLICATION IS RECOMMENDED UNDER PROVISIONS OF DODD 5230.09. I AM AUTHORIZED TO MAKE THIS RECOMMENDATION FOR RELEASE ON BEHALF OF:

the undersigned.

b. CLEARANCE IS REQUESTED BY 20130615 (YYYYMMDD).

c. NAME (Last, First, Middle Initial) Lathers, John, D.	d. TITLE Training Specialist
e. OFFICE MCCSSS, Director of Academics, Future Operations	f. AGENCY DON, USMC, TECOM, GTB

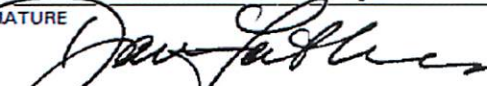
g. SIGNATURE 	h. DATE SIGNED (YYYYMMDD) 20130524
---	--

13-S-2100

Report Documentation Page

Form Approved
OMB No. 0704-0188

Public reporting burden for the collection of information is estimated to average 1 hour per response, including the time for reviewing instructions, searching existing data sources, gathering and maintaining the data needed, and completing and reviewing the collection of information. Send comments regarding this burden estimate or any other aspect of this collection of information, including suggestions for reducing this burden, to Washington Headquarters Services, Directorate for Information Operations and Reports, 1215 Jefferson Davis Highway, Suite 1204, Arlington VA 22202-4302. Respondents should be aware that notwithstanding any other provision of law, no person shall be subject to a penalty for failing to comply with a collection of information if it does not display a currently valid OMB control number.

1. REPORT DATE 22 AUG 2013		2. REPORT TYPE Final		3. DATES COVERED 1 Jan 2012 - 1 Mar 2013	
4. TITLE AND SUBTITLE A critical analysis of the U.S. Marine Corps 04XX logistics community				5a. CONTRACT NUMBER	
				5b. GRANT NUMBER	
				5c. PROGRAM ELEMENT NUMBER	
6. AUTHOR(S) Lathers, John, D, Sr.				5d. PROJECT NUMBER	
				5e. TASK NUMBER	
				5f. WORK UNIT NUMBER	
7. PERFORMING ORGANIZATION NAME(S) AND ADDRESS(ES) The author acted in a private capacity and not in connection with their official duties to prepare the study/manuscript.				8. PERFORMING ORGANIZATION REPORT NUMBER	
9. SPONSORING/MONITORING AGENCY NAME(S) AND ADDRESS(ES)				10. SPONSOR/MONITOR'S ACRONYM(S)	
				11. SPONSOR/MONITOR'S REPORT NUMBER(S)	
12. DISTRIBUTION/AVAILABILITY STATEMENT Approved for public release, distribution unlimited					
13. SUPPLEMENTARY NOTES The original document contains color images.					
14. ABSTRACT The U.S. Marine Corps logistics community fills multiple diverse billets integral to organizational success. This analysis explores enlisted and officer logistics military occupational specialties (MOSs) to determine if negative trends exist. Guiding resources are examined including the MOS Manual, training and readiness events, and promotion guidance and selection results. In all cases, findings demonstrate MOS role diffusion, duplicative responsibilities across multiple MOSs, lack of formal training opportunities or formal school attendance, and vague selection or advancement criteria. Further, multiple instances of misapplication of resources were noted. Finally, considerations for future personnel assignment are provided.					
15. SUBJECT TERMS U.S. Marine Corps; Logistics; Embarkation; Maintenance Management; Training and Readiness (T&R); formal military training					
16. SECURITY CLASSIFICATION OF:			17. LIMITATION OF ABSTRACT SAR	18. NUMBER OF PAGES 222	19a. NAME OF RESPONSIBLE PERSON
a. REPORT unclassified	b. ABSTRACT unclassified	c. THIS PAGE unclassified			

CLEARED
For Open Publication

AUG 06 2013 4

Office of Security Review
Department of Defense

A Critical Analysis of the U.S. Marine Corps 04XX Logistics Community

John D. Lathers

4/15/2013

The U.S. Marine Corps logistics community fills multiple diverse billets integral to organizational success. This analysis explores enlisted and officer logistics military occupational specialties (MOSs) to determine if negative trends exist. Guiding resources are examined including the MOS Manual, training and readiness events, and promotion guidance and selection results. In all cases, findings demonstrate MOS role diffusion, duplicative responsibilities across multiple MOSs, lack of formal training opportunities or formal school attendance, and vague selection or advancement criteria. Further, multiple instances of misapplication of resources were noted. Finally, considerations for future personnel assignment are provided.

13-S-2100

PREFACE

For the last 13 years I have worked as GS-civilian instructional designer/training specialist, initially with Logistics Operations School (LOS), then Logistics Training and Education Center of Excellence (LOGTECOE), and currently with MCCSSS Future Operations. Prior, as an active duty Marine, I served and retired after 21 years of honorable service as an ATC Systems Maintenance Chief.

Therefore, having arrived from a highly technical, aviation support field - which included years as a formal school instructor, evaluator, and courses coordinator - it quickly became apparent that there were few substantiated processes employed within the logistics field. Rather, what was more common was the haphazard collection of personality-driven procedures that often failed to coincide with established policy - or simply mimicked other MOS policy - if in fact policy existed at all.

While these observations were initially forming my own biases, I listened as other professionals also voice concerns about the logistics community as a whole. One officer mentioned the lack of mobility experience required for selection to 0430 Mobility Officer, another questioned the lack of post-secondary education. Someone else introduced the disparity of the TBS class ranking and MOS assignment of the logistics officer. Another officer questioned the expertise of the merged 0491 Logistics Chief - especially in light of historic formal school attendance. Even university colleagues posed perplexing questions concerning logistic officer roles and accountability.

As such, this project began years ago as an after-hour project during my doctoral studies. An extensive literature review was conducted of numerous published works (Naval Postgraduate School, Navy War College, etc.), NAVMCs, MCOs, MARADMINS, etc. Derived promotion data was then aligned to selection data and class graduation numbers were retrieved to identify trends. Finally, RFIs were received from LOS and The Basic School. The final product became a critical analysis of the 0411, 0431, 0481, 0491, 0430 and 0402 MOSSs.

The subjective conclusions and recommendations (beginning on page 102) come from a 34-year career Marine - both retired and GS-civilian. As such, my view is colored by my experience and background. Efforts to remain objective were most likely not completely successful. My apologies in advance. Regardless, this analysis is simply an integration of published references and official correspondence synthesized into a single structured document.

If this document creates angst or controversy - therefore requiring additional verification, analysis, and debate - then the hundreds of hours spent writing it will have certainly been worth the effort.

List of Tables

Table 1 Average TIG and TIS for 0411 MOS SSgt Allocations..... 21

Table 2 Results of the Independent t test for 0411 SSgt..... 22

Table 3 Average TIG and TIS for 0411 MOS GySgt Allocations..... 22

Table 4 Results of the Independent t test for 0411..... 23

Table 5 MOSs Receiving Maintenance Management Training..... 27

Table 6 0431 Career-level Training..... 29

Table 7 Average TIG and TIS for 0431 MOS SSgt Allocations..... 30

Table 8 Results of the Independent t test for 0431 SSgt..... 31

Table 9 MOSs Performing Embarkation Tasks..... 34

Table 10 BLESC (0431) to EWBC (3051) Course Resource Comparison..... 35

Table 11 Comparison of MOS Manual Required Formal Training..... 38

Table 12 Average TIG and TIS for 0481 MOS SSgt Allocations..... 39

Table 13 Results of the Independent t test for 0411 SSgt..... 40

Table 14 BLSSC Learning Objectives to 0481 1000-level T&R Events.... 42

Table 15 Average TIG and TIS for 0491 GySgt Allocations..... 45

Table 16 Results of the Independent t test for 0491 GySgt..... 45

Table 17 0491 MOS Promotions to Formal School Attendance..... 48

Table 18 0430 MOS Selection and Attendance to Formal Training..... 55

Table 19 Educational Level of Active-duty Warrant Officers & Chief
Warrant Officers 58

Table 20 Post Secondary Education Level of Comparable CSS MOSs..... 61

Table 21 Educational Level of Selected LDO Majors and LtCols..... 62

Table 22 2010 Warrant Officer Selection Results..... 70

Table 23 TIS of Warrant Officer Feeder Ranks Selected in 2010..... 71

Table 24 TIG of Warrant Officer Feeder Ranks Selected in 2010..... 72

Table 25 Average TIG, TIS and Age of CWO-3 Selections..... 73

Table 26 Results of the Independent t test for 0430 CWO-3s..... 73

Table 27 Average TIG, TIS and Age of CWO-3 Selections..... 74

Table 28 Results of Independent t test for 0430 CWO-4s..... 74

Table 29 Average TIG, TIS and Age of CWO-5 Selections (2006-09)..... 75

Table 30 Results of the Independent t test for 0430 CWO-5s..... 75

Table 31 Average TIG, TIS and Age of CWO3-5 Selections (2006-09).... 76

Table 32 Results of Independent t test for 0430 CWO3-5 Selections... 76

Table 33 Total U.S. Marine Corps Manpower Strength.....	80
Table 34 Average TIG, TIS and Age of LDO Major Selections.....	81
Table 35 Results of the Independent t test for 0430 LDO Majors.....	81
Table 36 Average TIG, TIS and Age of LDO LtCol Selections.....	82
Table 37 Results of the Independent t test for 0430 LDO LtCols.....	83
Table 38 American Council of Education (ACE) Recommendations.....	95
Table 39 Comparison of 0402 and 0491 MOS T&R Events.....	97
Table 40 Unrestricted Captain Selections by MOS.....	99
Table 41 Unrestricted Major Selections by MOS.....	101
Table 42 Unrestricted LtCol Selection by MOS.....	102
Table 43 Highest Education Level for CW03-5s of Comparable CSS MOSs	120
Table 44 Highest Education Level Reported by LDO Majors and LtCols.	121
Table 45 MOSs Performing the Six Functions of Tactical Logistics and Associated Training	137
Table 46 Officer to Enlisted MOS Strength.....	140

Table of Figures

Figure 1 U.S. Navy Rank & Rate Insignia	9
Figure 2 Training Input Plan (TIP) MOS Training Track	16
Figure 3 Training Input Plan (TIP) Course Requirements	17
Figure 4 0430 Warrant Officer Feeder Rank and MOS	64
Figure 5 0430 CWO-2 Feeder Rank and MOS	65
Figure 6 0430 CWO-3 Feeder Rank and MOS	66
Figure 7 0430 MOS CWO-4 Feeder Rank and MOS	67
Figure 8 0430 CWO-5 Feeder Ranks and MOSS	67
Figure 9 0430 LDO Captain Feeder Ranks & MOSS	68
Figure 10 0430 LDO Major Feeder Ranks & MOSS	69
Figure 11 0430 LDO LtCol Feeder Ranks and MOSS	70
Figure 12 Logistics Officer Course (LOC) Required Personnel	93
Figure 13 LOC Instructor to Student Ratios by Hours and Percent	94
Figure 14 Career Progression of a Highly Technical MOS (5902 MOS)	115
Figure 15 Career Progression within the 0430 MOS	116
Figure 16 0402 and 0302 MOSS TBS Graduate Class Rankings	135

"Everyone is entitled to his own opinion, but not to his own facts."

- Daniel Patrick Moynihan

The true role of logistics in any organization is to increase positive returns through improved processes and organizational efficiency. As such, success is attained by effectively performing specific functions to meet (or exceed) projected goals - concurrent with minimizing potential process risks and eliminating unnecessary personnel, procedures, or expenditures. Civilian business logistics employ a multitude of systematic processes designed to quantify trend analysis data of inventories, storage, distribution, clients, personnel performance, and deliverables. Accordingly, civilian logistics becomes an all-encompassing, multi-faceted, global construct that combines a wide assortment of highly specialized, task-orientated, independent yet interrelated, individual components, processes and entities essential to meeting a specific goal. Consequently, by reliably predicting events and required actions (and thereby maximizing efficiencies, reducing risk, and eliminating waste), the primary focus of civilian logistics is to ensure a consistent, measurable return on investment - be it for profit or not.

On the other hand, military logistics is a "branch of military science and operations dealing with the procurement, supply, and maintenance of equipment, with the movement, evacuation, and hospitalization of personnel, with the provision of facilities and services, and with related matters".¹ While this definition is similar to many civilian functions, military logistics cannot hold the same

¹ Retrieved 19 November 2012 from Dictionary.com at <http://dictionary.reference.com/browse/logistics>

goals as civilian logistics simply because military structure and equipment are built and designed to win battles, not to increase the bottom line. Rarely are cost-savings measures considered during an armed conflict - M-16 rounds are only conserved in anticipation of the next battle not to "sell-back" for a profit - therefore, the concept of military logistics remains intangible, a pseudo-bastard child of their civilian sibling.

Multiple web-based searches for logistics return images of global interconnectivity populated by established fields of trucks, planes, ships, and trains. These multiple images characterize logistics as a worldwide delivery system, like United Parcel Service (UPS®). Although logistics remains in its primal state - a composition by degree - of the parts, pieces, personnel, and processes necessary for any activity to succeed - be it UPS® or a military campaign.

Successful process managers - either civilian or military - continuously seek to improve their organizations by examining performance measures and analyzing system functions to determine the interoperability of multiple factors. If areas of improvement are identified, needs assessments are conducted to resolve the situation or improve the process. The needs assessment may determine older equipment requires refreshing, that the placement of employee workstations interrupts the flow of materials, or that personnel lack certain occupational skills. In the case of the later, training is often employed as a solution to specific organizational needs involving employee skill building.

Training specialists and instructional systems designers understand that creating relevant curriculum begins when the need (now a requirement) can be dissected into sub-components that, when systematically combined, create a concise learning objective. Learning objectives are critical to successful training as they identify not only the definitive action to be performed but also under what conditions and measurement standards successful accomplishment will be defined. As such, the organization's *need* becomes a well-defined and comprehensive end-state (or desired behavior) that clearly identifies the specific conditions and level of anticipated performance mastery expected of the participant.

Highly technical fields like electronics and maintenance operate to exact specifications that allow for limited deviation from explicit procedures. Usually there are also system-specific visual and tactile training devices available along with well-articulated troubleshooting and repair processes derived from applicable technical publications and operating manuals. As such, curriculum designers are often better prepared to conceptualize well-articulated, process-driven learning objectives that incorporate descriptive behaviors, conditions, and standards. Conversely, designing non-technical, indeterminate training curriculum beyond rudimentary system operations is somewhat more challenging, particularly in any field that lacks a clearly defined identity built upon a purpose-driven foundation of intelligible roles, invariable duties, concise responsibilities, and universally applicable processes.

Instructional designers often begin the curriculum design process by building on the learner's previously obtained knowledge and experience, which encourages connectivity between new and old material. Visual imagery is one of the more successful methods used to orient new material to already known concepts and imagery. Current theories in neuroscience reveal that "90 percent of the brain's sensory input is from visual sources" and that the brain has an "immediate and primitive response to symbols, icons, and other simple images" (Jensen, 2008, pg. 56). As such, by creating visual symbology that effectively represents the subject content, the designer is able to create an aggregate of the purpose, content, specific acronyms, broad processes, and expected outcomes of the course.

What is more important, is that these images create mental models - or graphic representations of the narrative - which serve an individual with instant comprehension of what 'something' likely stands for. For example, when an experienced driver sees a red octagon at the end of street they recognize the shape as a stop sign - without having to read the lettering. Conceptually, they retrieve specific mental constructs associated with the stop sign, to include the distance required to stop, the amount of tension to apply to the brake pedal, applicable laws, right of way, etc., usually at the unconscious level. The ability to envision a definitive end-state allows the curriculum designer to create a comprehension course capable of activating the student's inherent cognitive resources that contribute to improved learning. A good example of mental imagery is employed by the U.S. Navy's use of visual representation to display

ratings to their rank insignia as shown in Figure 1. This allows not only for a prompt understanding of the individual's level of responsibility, but also a ready assessment of their area of expertise.



Figure 1 U.S. Navy Rank & Rate Insignia

Therefore, symbols and images aid in comprehension but more importantly the speed of comprehension. For example, the image of a packing crate, forklift, or manifest adds a visual construct of supply functions like embarkation or warehousing, while a large military truck creates a mental image of transport convoys if moving down the road, or vehicle maintenance if wrenches are also included. Stacks of money or cancelled checks create mental symbols of finance or disbursement while images of radio waves, roving molecules, or a SCUBA bubble equate to occupations in communication, electronics, or combat water survival.

As such, most occupations can be concisely represented by a single symbol or grouping of symbols; i.e., mechanics are represented by wrenches, electronics by electrons, tanks by silhouette, medicine by the rod of Asclepius, aviation by aircraft, etc. This is the same

for the U.S. Marine Corps, where it is relatively easy to visualize a specific symbol for any occupational field - from food service (recipes and cookware) to legal (scales of Justice) to engineering (bulldozer), etc. Most unit logos, patches, and challenge coins exhibit this particularly well. This is extremely valuable in occupations with high-turnover (like the military service) where even if an individual's personal experience and knowledge may vary, the overall mental construct of an occupational field's subject driven processes, specialized functions, and equipment, remain the same regardless.

Unfortunately, the logistics field appears to be the one occupational field that the average U.S. Marine seems unable to visualize as a clearly defined symbol. That is not to say that individual components within logistics cannot be symbolized; e.g., motor transport, supply, engineering, etc., but that due to the ubiquitous nature of logistics it is impossible to foment a single meaningful concept that universally transfers across an organization as culturally diverse as the U.S. Marine Corps.

This poses a significant problem for organizational leaders, future planners, trainers, and designers of training. Creating relevant course curriculum is a difficult task to begin with but it become more so in situations where the subject MOS lacks a cogent and persistent visual representations capable of producing unvarying imagery across an organization. The nature of logistics has become a generic amalgamate of multiple diverse and dissimilar specialty fields so interminably sweeping and ambiguous in scope and function as to

lack practical definition. Therefore, without practical guidance, how then can objective and measureable logistics-related performance standards be developed to gauge individual competency and guide performance orientated specialized training?

Any attempt to answer the basic question of defining the U.S. Marine Corps *functional concept of logistics* requires a comprehensive review of multiple source references including, the Marine Corps Order (MCO) 1200.17C Military Occupational Specialties (MOS) Manual,² the Navy and Marine Corps (NAVMC) 3500.27B Logistics (LOG) Training and Readiness (T&R) Manual,³ and the Training & Education Command (TECOM) MOS Training Input Plan (TIP) Training Track and course requirements for FY 2012-2016. Unless otherwise specifically noted, these references by version and publication date are utilized exclusively for this analysis. Supplemental T&R manuals, course descriptive data (CDD), programs of instruction (POI), and associated references were also used and are identified specifically within this document.

Other available resources were analyzed to gain insight into the 04XX community, specifically, Marine Administrative Messages (MARADMINs), All Navy messages (ALNAVS), selection board results, and formal school attendance and graduate reports. Some data collection was hindered, as many of the requisite documents were unattainable, incorrect, or incomplete. For example, on the official U.S. Marine Corps website,⁴ MARADMIN 532/02 is supposed to report Calendar Year

² Marine Corps Order (MCO) 1200.17C, Military Occupational Specialties (MOS) Manual, dated 29 June 2011.

³ Navy Marine Corps (NAVMC) 3500.27B, Logistics (LOG) Training and Readiness (T&R) Manual, dated 11 May 2011.

⁴ The official U.S. Marine Corps website <http://www.marines.mil/News/Messages/MARADMINs.aspx>.

(CY) 2002 Approved Selections to Staff Sergeant, instead the link displays MARADMIN 511/02 CY 2002 Active Reserve Staff Noncommissioned Officer (SNCO) Selection Board results. Cases of faulty or inconsistent data were excluded where appropriate throughout this analysis.

It also became apparent during data collection that some case information - specifically dates - were suspect; therefore, 'selection' infers either the selection date or promotion date, unless otherwise specified. As such, individual cases were only analyzed by the highest (terminal) rank attained - not by previous ranks.

In the U.S. Marine Corps, every Marine is first and foremost a rifleman, who incidentally labor within clearly defined military-orientated occupations. It could also be easily argued that every Marine also functions as an integral component of every organization's logistics. Simply put all Marines plan, manage, source, acquire, create, account, maintain, repair, distribute, deliver, or utilize something - regardless of the occupational specialty - in support of the ground combat element's proverbial "point of the spear". Because a common understanding of logistics is essential to communicate orders and directives, this analysis began with a review of current logistics-related U.S. Marine Corps doctrine for historical precedence and foundational reference.

In the U.S. Marine Corps, doctrine "establishes the way we practice our profession" and "provides the basis for harmonious actions and mutual understanding" (Marine Corps Doctrinal Publication

(MCDP) 1-0, Marine Corps Operations,⁵ pg. 55); therefore, clear operational definitions are critical to unit continuity. Doctrine becomes particularly integral to organizations where individuals from different cultures - possessing differing intellects and skills - must cohesively interact to "sustain a high tempo of operations" (MCDP-4, Logistics, pg. 105).⁶

Confusion over the military definition of logistics begins in current and applicable doctrine, specifically, Marine Corps Warfighting Publication (MCWP) 4-6, Marine Air Ground Task Force (MAGTF) Supply Operations,⁷ that states, "Combat service support (CSS) is logistics for the tactical level of war" (pg. 1-1). Conversely, the also current and applicable MCWP 4-11, Tactical-level Logistics,⁸ classifies tactical-level logistics to "include combat service support" (pg. 1-3). Upon comparison, both CSS and logistics have similar objectives, albeit worded slightly different, where "combat service support is to sustain all elements of an operating force (MAGTF)" (MCWP 4-11.7, pg. 1-1) and effective logistics "emphasizes the need for detailed planning and close integration of logistic capabilities of both supported combat units and supporting combat service support units" (MCWP 4-11, pg. 1-1).

What makes defining logistics most difficult is that both combat service support (CSS) and logistics are categorized into the same six

⁵ Marine Corps Doctrinal Publication (MCDP) 1-0, Marine Corps Operations, dated 9 August 2011.

⁶ Marine Corps Doctrinal Publication (MCDP) 4, Logistics, dated 21 February 1997, was last reviewed in March 2005 and is current.

⁷ Marine Corps Warfighting Publication (MCWP) 4-6, MAGTF Supply Operations, dated 29 February 1996, was redrafted as MCWP 4-11.7, MAGTF Supply Operations in 24 June 1998.

⁸ Marine Corps Warfighting Publication (MCWP) 4-11, Tactical-level Logistics, dated 13 June 2000, superseded Fleet Marine Force Manual (FMFM) 4-1, Combat Service Support Operations, dated 12 July 1993.

functional areas of supply, maintenance, transportation, health services, and other services (Joint Publication (JP) 1-02, Department of Defense Dictionary of Military and Associated Terms, 2010,⁹ pps. 50, 178, and MCWP 4-11, p. 1-1). The simple interchangeability of the terms logistics and combat service support seems to contribute significantly to the lack of clearly definable titles, functions, sub-functions, roles, and responsibilities. As such, without clear guidance, an accurate and meaningful definition of tangible logistics remains vague yet all encompassing.

The U.S. Marine Corps MOS Manual is the foundational source document used to classify and assign personnel by duties, skill attributes, and requirements necessary to gain and maintain MOS classification. The MOS Manual employs a four-digit occupational specialty numbering system to identify related occupations fields that are then grouped into similar functional areas. Specific occupational field T&R Manuals outline all current and applicable performance standards by billet and grade for that particular MOS.

T&R Manuals establish performance based criteria into successive performance levels beginning with the individual entry-level 1000-level and career-level 2000-level events.¹⁰ A U.S. Marine's career begins with recruit training and subsequent assignment to a specific MOS. After recruit training, initial (or entry-level) training provides the essential and basic core skills necessary to perform within a specific MOS and is usually reserved for the ranks of private

⁹ Joint Publication (JP) 1-02, Department of Defense Dictionary of Military and Associated Terms, dated 8 November 2010 as amended through 15 December 2012.

¹⁰ Although individual T&R events progress from individual training events to collective training events, this study will only examine the 1000- and 2000-level events.

(Pvt/E-1), private first class (PFC/E-2), and lance corporal (LCpl/E-3). Career training is designed to progressively increase overall MOS-related skills and knowledge most often for the ranks of corporal (Cpl/E-4), sergeant (Sgt/E-5), and staff sergeant (SSgt/E-6). Promotion to noncommissioned (NCO) and staff noncommissioned officer (SNCO) are considered significant milestones in an enlisted Marine's career. Both signify an individual's ability to competently and proficiently perform - and lead others - within their MOS, albeit to differing degrees. Advanced-level training is structured for senior SNCOs and is designed to increase overall MOS knowledge and skills for the ranks of gunnery sergeant (GySgt/E-7), master sergeant (MSgt/E-8) and master gunnery sergeant (MGySgt/E-9). Senior SNCOs are considered - due to their rank - the MOS experts who shape the future of the MOS. Excerpts from the MOS Manual and Logistics T&R Manual are provided in the Appendices for the logistic MOSs explored herein.

The TECOM TIP Training Track is published annually to identify formal training requirements necessary to obtain or sustain a given MOS. Requirement sponsors and MOS specialists (individuals who are assigned as subject matter experts for a specific MOS (or group of very similar MOSs) who are readily accessible for input) coordinate training quotas for the TIP and monitor/manage student throughput and fill rates. The Deputy Commandant for Manpower and Reserve Affairs (DC, M&RA) is generally responsible for all entry-level and skill progression training (active and reserve, officer and enlisted) leading to a MOS and all lateral move training. Occupational Field (OccFld) Managers (who are assigned and responsible for a grouping of

MOSs or a category of MOSs) and MOS Sponsors provide for all non-primary MOS and some skill progression training identified in the TIP while Marine Forces Reserve (MARFORRES) provides for all MOS sustainment (non-entry) Selected Marine Corps Reserve (SMCR) training. Figure 2 shows an example of the TIP MOS Training Track showing the MOS (0411) and the MOS Title (Maintenance Management Specialist) followed by the MOS type (Enlisted Primary).

FY 2012-2016 Training Input Plan (TIP) - MOS Training Tracks

0411 MAINTENANCE MANAGEMENT SPECIALIST					
<i>MOS Type: Enlisted Primary</i>					
Track	Sequence	CID/Title/School/Location	FY12 Length	Rqmt	
1	1	M03LAD7 BASIC MARINE CORPS INTEGRATED MAINTENANCE MANAGEMENT SYSTEM LOGISTICS OPERATIONS SCHOOL at MCB CAMP LEJEUNE, NC	20	235	

COURSE IDENTIFIER (CID) points to **M03LAD7**

Track Length: 20 points to **20**

LENGTH (IN CALENDAR DAYS) points to **20**

Figure 2 Training Input Plan (TIP) MOS Training Track

The TIP training track also identifies the approved course (or courses) required to produce a MOS and the sequence in which courses are to be received. The seven-digit Course Identifier (CID) is used to identify the military service providing the training (M = Marine), the location of the course (03 = Marine Corps Base, Camp Lejeune), the Service School Code (a unique code specifying the formal course of instruction), and the actual school providing the training (7 = Logistics Operations School). The formal course title is shown next followed by the course length (shown in calendar days) for one course iteration. Finally, the annual number of projected students (FY12, Rqmt) is shown for planning purposes.

The TIP course requirements page provides much of the same information provided within the training tracks with a few key differences. Most importantly, the TIP course requirements page identifies the sponsor and student type codes beneath the MOS and MOS Title. Figure 3 identifies and defines the four different requirement sponsors (MPP-20, MPP-25, RAM-20 and RAP) providing formal school seats for the four different student types (0EE, 1E, 0EF and 2E) programmed to attend. The TIP identifies the annually projected number of students requiring training (by trimester) necessary to meet organizational staffing and MOS needs.

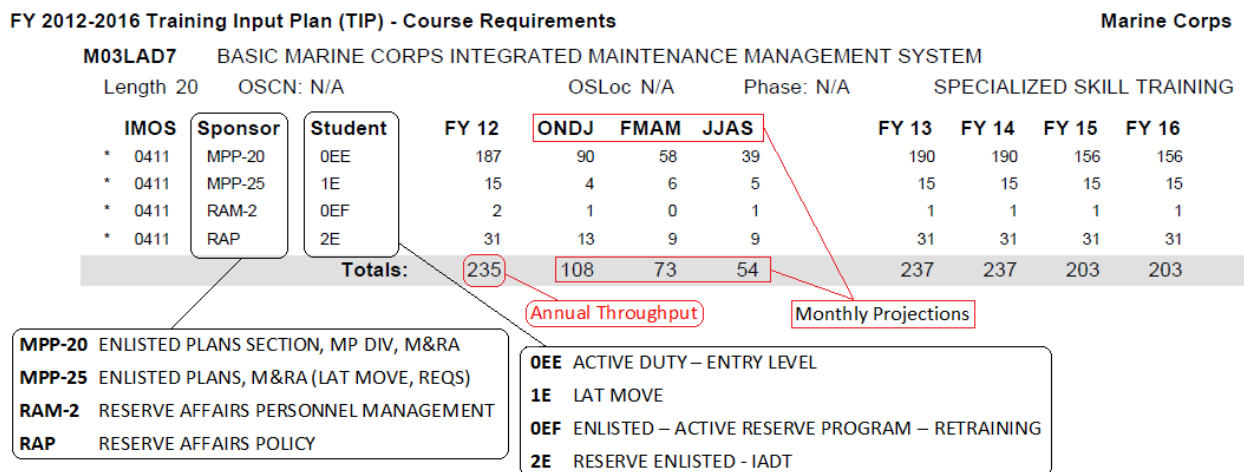

Figure 3 Training Input Plan (TIP) Course Requirements

Finally, the TIP reports current and out-year plans for specialized MOS skill training. As a sequence of approved and funded courses, the TIP serves as the cornerstone for budgeting and personnel plans of formal school and supporting establishments overhead costs (instructor and support staff personnel, facilities, training aids, etc.). As an inability to successfully train leads to a decline in operational readiness, it is extremely important to consider all

issues that affect the need for training. An overestimation of student requirements will over commit funds for unfilled seats, empty classrooms, and underutilized instructor and staff personnel (and over utilized Marines in the field), while an underestimation could lead to increased student awaiting training time, classroom overload, training bottlenecks, or abbreviated training cycles.

Utilizing the above resources, a critical analysis of the U.S. Marine Corps logistics community, specifically the 04XX military occupational specialties, was conducted. This analysis will explore the specific duties and responsibilities, guiding documentation, training, and unique characteristics of six logistics MOSs. They are the 0411 Maintenance Management Specialist MOS, 0431 Logistics/Embarkation Specialist MOS, 0481 Basic Landing Support Specialist MOS, 0491 Logistics/Mobility Chief MOS, 0430 Mobility Officer MOS, and the 0402 Logistics Officer MOS.¹¹ With each MOS, the MOS Manual, time in grade (TIG) and time in service (TIS) (where applicable), Training and Readiness (T&R) events, and formal learning were analyzed, and the findings presented. A discussion summary is provided after the last MOS has been introduced, providing conclusions and considerations. This analysis began with the 0411 MOS.

0411 Maintenance Management Specialist MOS

The 0411 Maintenance Management Specialist MOS provides advice and assistance to the unit's commodity sections to ensure required maintenance of ground equipment is planned, conducted, and reported in

¹¹ The 0451 Airborne and Air Delivery Specialist MOS and the 0471 Personnel Retrieval and Processing Specialist MOS were not examined due to their highly specialized and exclusively isolated career tracks.

approved automated information systems. A single MOS performing these functions is in stark contrast to other ground MOSs and the aviation community where maintenance management duties are more often than not assigned as collateral duties (like Safety, Embarkation, Tool Inventory, Test Equipment, HAZMAT, etc.) and training is provided locally or gained via Managed On-the-Job-Training (MOJT).

MOS Manual

There are a few confusing issues regarding the MOS Manual requirements for the 0411 MOS. First, an entry-level Marine¹² initially receives the 0411 MOS by successfully completing the 20-day,¹³ MOS-producing Basic Maintenance Management Specialist Course (BMMSC),¹⁴ per the MOS Manual (Appendix A) and TIP Training Tracks; although, the MOS Manual is somewhat confusing in regards to career progression training. Specifically, the MOS Manual fails to identify any required training beyond the entry-level BMMSC located on page 3-56; although, Figure 3-4, located on pages 3-64/65, lists additional required training as the 29-day, MOS-sustaining Intermediate Maintenance Management Specialist Course (IMMSC)¹⁵ for Cpls, Sgts, SSgts, and GySgts within the 0411 MOS.

Beyond the contradictory guidance already noted, it seems curious that Cpls, Sgts, SSgts, and GySgts in the 0411 MOS are directed to attend the same career-level formal course, as it would normally be

¹² Based on the needs of the operational forces, some individuals are approved to move laterally from one MOS into another. The 0411 MOS allows lateral-move sergeants and below the opportunity to obtain the 0411 MOS by successfully completing the BMMSC.

¹³ The Basic Maintenance Management Specialist Course (BMMSC) is identified in the TIP training track as 20 calendar days; although the Course Descriptive Data (CDD) dated 10 October 2012 identifies 32-training days.

¹⁴ Basic Maintenance Management Specialist Course, CID M03LAD7 dated 10 October 2012.

¹⁵ Intermediate Maintenance Management Specialist Course (IMMSC) Program of Instruction dated 22 May 2012.

expected that the skill-sets exhibited and required of any GySgt are significantly higher than those expected of a Cpl. In addition, this means that if a 0411 Cpl attends the course after three years of service, they are not required to attend any other MOS-sustaining formal training throughout the remainder of their career - from Sgt through MGySgt - be it up to 30 years. This raises the question of how to determine skill-progression and associated competency - to rank order individuals for promotion - if there is no identifiably different expectations in the 0411 MOS. It also seems unrealistic that all of the skills a 0411 Marine needs to succeed throughout their entire enlisted career - can be condensed into a single month - or at the most two months - of formal training.

Finally, according to the MOS Manual, commanders can award the 0411 MOS as an alternate MOS after an individual completes two Marine Corps Institute (MCI) distance-learning correspondence courses and performs the duties identified in the T&R Manual for a minimum of six months. In the age of dwindling resources, this poses the question of why formal training is necessary at all.

Time in Grade (TIG) and Time in Service (TIS)

From 2002 through 2012, there were 34,940 SSgt allocations open for all MOSs of which 215 went to the 0411 MOS (.62%). By calculating the Armed Forces Active Duty Base Date (AFADBD) against the selection board date, the time in service (TIS) required for selection for individual MOSs could be determined. The time in grade (TIG) could also be calculated using the date of rank (DOR) of eligible Marines to the selection board date. Promotion zone dates were utilized for both

TIS and TIG calculations except in cases where promotion zone dates were not listed and either below-zone or above zone dates were used.

Table 1 presents the average TIG and TIS for 0411 SSgt allocations as well as the average TIG and TIS for all other MOSs with SSgt allocations. (Those cases where the TIG and TIS were not identified were discarded). The findings demonstrate the average TIG and TIS of the 0411 SSgt was 3.44 years and 8.46 years, respectively.

Table 1 Average TIG and TIS for 0411 MOS SSgt Allocations

SSGT	MOS	N	M	SD	Std. Error Mean	Range
TIG	0411	215	3.4433	0.4231	0.0289	2.68 - 4.32
	ALL	31961	2.6615	0.8556	0.0048	0.53 - 6.87
TIS	0411	215	8.4608	1.2268	0.0837	6.42 - 10.78
	ALL	31961	7.1597	1.4104	0.0079	2.41 - 20.92

Because the TIG and TIS mean averages of the 0411 MOS were not dependent on the mean averages of all other MOSs, an independent sample t-test was conducted to produce the probabilities necessary to determine statistical significance. The results of the t test shown in Table 2, indicate that SSgts in the 0411 MOS required a higher average TIG (more time in grade as a sergeant) than the average TIG required for all other MOSs and that the differences were statistically significant ($M = 3.443$, $SD = .423$) to all other SSgts ($M = 2.662$, $SD = .856$) conditions; $t(225.94) = 26.733$, $p = .000$).

Table 2 Results of the Independent t test for 0411 SSgt

SSGT	F	Sig.	t	df	Sig. (2- tailed)	Mean Dif.	Std. Error Dif.	95% Confidence Interval of the Difference	
								Lower	Upper
0411									
TIG	104.900	0.000	26.733	225.94	0.000	0.782	0.029	0.724	0.840
TIS	6.163	0.013	15.483	217.82	0.000	1.301	0.084	1.136	1.468

The probability of getting a t value of 26.733 with 225.94 degrees of freedom is very small, as our p value of .000 reveals. Additionally, 0411 MOS allocations to SSgt required a higher average TIS (more years in service) than the average TIS required for all other MOSs and that the difference was also statistically significant (M = 8.46, SD = 1.227) to all other SSgts (M = 7.16, SD = 1.41) conditions; $t(217.82) = 15.483, p = .000$).

From 2003 through 2012, there were 16,665 GySgt allocations open for all MOSs of which 145 were allocated for the 0411 MOS (.87%). Table 3 presents the average TIG and TIS for 0411 GySgt allocations as well as the average TIG and TIS for all other MOSs with GySgt allocations. The average TIG and TIS of a GySgt in the 0411 MOS was 3.09 years and 9.35 years, respectively.

Table 3 Average TIG and TIS for 0411 MOS GySgt Allocations

GYSGT	MOS	N	M	SD	Std. Error Mean	Range
TIG	0411	145	3.0928	0.6777	0.0563	2.42 - 4.24
	ALL	16520	2.9169	0.9327	0.0073	1.20 - 7.77
TIS	0411	145	9.3510	1.0326	0.0858	8.23 - 11.19
	ALL	16520	7.7230	2.7384	0.0213	3.79 - 13.73

The results of the t test presented in Table 4 indicate that 0411 GySgts also required a higher TIG average (a longer time as a SSgt)

than what was required for GySgts from all other MOSs and that the differences were statistically significant (M = 3.093, SD = .677) to all other GySgts (M = 2.917, SD = .933) conditions; $t(148.83) = 3.10$, $p = .002$).

Table 4 Results of the Independent t test for 0411

GYSGT	F	Sig.	t	df	Sig. (2- tailed)	Mean Dif.	Std. Error Dif.	95% Confidence Interval of the Difference	
								Lower	Upper
0411									
TIG	10.651	0.001	3.10	148.83	0.002	0.176	0.057	0.064	0.288
TIS	23.886	0.000	18.426	162.32	0.000	1.628	0.088	1.454	1.803

Additionally, 0411 MOS allocations to GySgt required a higher average TIS (more years of service) than what was required for GySgts in all other MOSs and that the difference was statistically significant (M = 9.351, SD = 1.033) to all other SSgts (TIS M = 7.723, SD = 2.738) conditions; $t(162.32) = 18.426$, $p = .000$).

The findings indicate that the 0411 MOS requires its SSgts and GySgts to have significantly more experience in grade and significantly more time in service than other MOSs selecting SSgts and GySgts during the same time; although, the reasons and outcomes cannot be readily identified. One possibility for the delay could be that promotions in the U.S. Marine Corps occur due to attrition; that is, promotions only occur when there is a vacancy, projected vacancy, or force restructure.¹⁶ For example, a Marine with the highest rankings and scores, most deployments and longest TIG and TIS cannot be promoted if there are no openings in their MOS; whereas, another Marine from a different MOS with lower rankings and scores, fewer

¹⁶ The Marine Corps does allow for meritorious promotions in specific cases per MCO P1400.32D, Ch 2, Marine Corps Promotion Manual, Volume 2, Enlisted Promotions, dated 14 June 2012.

deployments and less TIG and TIG can be immediately promoted if a vacancy exists. The findings appear to indicate that Marines in the 0411 MOS are staying longer before separating or retiring - resulting in fewer opportunities for advancement.

Training and Readiness (T&R) Events

Individual and collective performance events are essential behaviors performed under set conditions to prescribed standards as described within respective occupational field's T&R Manuals. T&R events identify individual MOS behaviors and associated performance standards necessary to support organizational requirements. Marines are expected to maintain technical MOS proficiency of the T&R events assigned to their grade or billet. As such, for the entire 0411 MOS, there are only 20 T&R events listed - for the ranks of private through MGySgt (Appendix B). Eleven of these T&R events are 1000-level (core-skill) essential performance events required for private through Sgt and nine are 2000-level (career-progression) essential performance events required for Cpl through MGySgt.

Although, the 04XX T&R Manual does separate performance standard levels, it also reveals that there is no difference in the 1000-level performance standards expected of a 0411 private to that of a 0411 Sgt nor any difference in the 2000-level performance standards required of 0411 Cpl to that of an 0411 MGySgt. While it could be somewhat easier to rationalize that a 0411 private could be expected to meet the same standards of performance as a 0411 Sgt, it is implausible to believe that a junior 0411 Cpl could possibly be expected to perform the same

events to the same standard as a senior 0411 MGySgt, as it is currently directed by the 04XX T&R manual.

Formal Learning

Formal schools and training detachments ensure course curriculum meet required MOS skill training requirements and career-progression training designated "formal" (and not Managed-on-the-Job training) as established by the respective T&R Manual.

All resources in the formal schools are purportedly driven by the number of programmed students as decided by the occupational field (OccFld) sponsors, Manpower Branch (as determined by attrition and retention), and most importantly by the needs of the operating forces. Therefore, each year the Training Input Plan (TIP) is created to identify the number of students who will attend any specific formal course. A determination is then made concerning class size and class iterations, required training standards, equipment, number of instructors, etc., and reported in the course's resource document. This document, called a Course Descriptive Data (CDD), calculates the number of students, by the number of class iterations, and the training hours and methodology, to compute the required number of instructors necessary to meet the training mission. Although, rarely utilized verbatim the CDD does justify instructor and support staff on organizational Tables of Organization (T/O) and associated training resources on organizational Tables of Equipment (T/E). Additionally, formal school attendance requires temporary additional duty (TAD) away from the student's work area. Even in cases where the student is attending entry-level training as a new acquisition, they were

recruited to fill a vacancy or projected vacancy and therefore still impact their future work site. When a student is away from their normal duty station/work-center, their co-workers must increase their efforts to meet organizational goals and requirements. Herein, the question of budgeting and personnel - especially concerning formal school overhead costs (instructor and support staff personnel, facilities, materials, etc.) must be considered.

The 20-training day, entry-level Basic Maintenance Management Specialist Course (BMMSC)¹⁷ was created to meet the 0411 T&R events established for Sgts and below using the eleven 1000-level T&R events. Six instructor staff (1-MSgt, 1-GySgt, and 4-SSgts) and twelve support staff (1-Major, 1-Captain, 1-MGySgt, 2-SSgts, 1-Sgt and 1-GS12, 2-GS9, 1-GS7, 1-GS5, and 1-GS4) are identified as required within the BMMSC resource documents.¹⁸ BMMSC convenes seven class iterations for 280 students annually, utilizing 86.9% (196) of the 228 available training days.¹⁹ This also equates to a little over half (53.6%) of the calendar year.

Reviewing the BMMSC learning objectives reveals that the majority of 0411 MOS T&R events used to build the BMMSC are nearly identical to other ground MOSS, specifically the Ground Supply, Motor Transport, Utilities, and Engineering occupational fields. For example, the 3043 Supply Administration and Operations Specialist MOS provides similar maintenance management curriculum in their Enlisted Supply Basic Course (ESBC). Initially, both courses seem appropriate and necessary

¹⁷ (see Footnote 14)

¹⁸ (see Footnote 14)

¹⁹ Based on FY-12, 366 calendar days less 105 weekends, 10 federal holidays, 19 non-training days, and 10 1/2 training days.

to meet established training requirements. Although, upon critical review, the training goals of BMMSC are either generic to many other MOSs or appear relatively similar to the training goals found within the ESBC. Incidentally, both are entry-level MOS-producing courses.

A cursory review of 25 combat service support (CSS) MOSs reveals numerous T&R-directed, maintenance management performance events required to initially gain - and then sustain - that unique MOS (Table 5).

Table 5 MOSs Receiving Maintenance Management Training

0402 Logistics Officer (F)
0451 Airborne and Air Delivery Specialist (F)
0491 Logistics/Mobility Chief (F)
1120 Utilities Officer (F)
1141 Electrician
1142 Engineer Equipment Electrical Systems Technician
1161 Refrigeration and Air Conditioning Technician
1169 Utilities Chief (F)
1171 Water Support Technician
1302 Combat Engineer Officer (F)
1310 Engineer Equipment Officer (F)
1349 Engineer Equipment Chief (F)
1361 Engineer Assistant
1371 Combat Engineer (F)
1390 Bulk Fuel Officer (F)
1391 Bulk Fuel Specialist
3002 Ground Supply Officer (F)
3510 Ground Supply Operations Officer (F)
3043 Supply Administration and Operations Specialist (F)
3051 Warehouse Clerk (F)
3510 Motor Transport Maintenance Officer (F)
3521 Automotive Maintenance Technician (F)
3529 Motor Transport Maintenance Chief (F)
3531 Motor Vehicle Operator (F)
3537 Motor Transport Operations Chief (F)

In this situation, it appears that multiple MOSs are creating maintenance management lesson materials within geographically separate

formal schools to meet their particular MOS needs. To meet the individual MOS requirements formal school training (F) is mandated by nineteen of the twenty-five MOSs.

Although duplicitous lesson material is usually rationalized by differing MOSs requiring unique "MOS flavored" training; e.g., maintenance management with a motor transport flavor, it seems inefficient for MOSs with nearly identical training goals that perform many of the same behaviors upon graduation would require individual MOS-specific formal courses - especially when the 0411 MOS (and associated skill sets) can be awarded by the commander after completion of two MCI courses and six months experience.

The 04XX T&R Manual directs a "formal" training setting for all 2000-level performance events for 0411 Cpls up through the rank of MGySgt. The 29-training day Intermediate Maintenance Management Specialist Course (IMMSC)²⁰ incorporates the nine 2000-level 0411 T&R events, although the target population only includes the ranks of Cpl through GySgt. This raises the question of where 'formal' training will be obtained for the 0411 MSgt and MGySgt, as there are no required formal training courses established for any rank above GySgt. Irregardless, this means the formal school has designed a course where the more senior SNCOs is trained and evaluated on the exact same course material, in the same training setting, and to the same level of performance expectation as the most junior NCO.

²⁰ (see Footnote 15)

0431 Logistics/Embarkation Specialist MOS

Appendix C captures the MOS Manual's description of the 0431 Logistics/Embarkation Specialist MOS as an individual who "prepares supplies and equipment for embarkation" and supports "the movement of personnel, supplies, and equipment via all modes of transportation using commercial and military assets" (pg. 3-57). Using automated information systems, personnel in the 0431 MOS are able to "account, track, and interface movement data with load planning programs" to support the in-transit visibility specified purpose of preparing "aircraft and ship load plans" (pg. 3-57).

MOS Manual

The MOS Manual directs that an entry-level Marine may initially receive the 0431 MOS by successfully completing the 19-training day, Basic Logistics/Embarkation Specialist Course (BLESC)²¹ although, the MOS Manual is confusing in regards to career progression training. On page 3-57, the MOS Manual fails to identify any required training beyond the entry-level BLESC, while Figure 3-4, located on pages 3-66/69, and reprinted in Table 6, reports additional required training.

Table 6 0431 Career-level Training

For 0431 SSgt: Advanced Logistics/Mobility Course;

For 0431 Cpl and Sgt: Logistics/Embarkation NCO Course;

For 0431 Cpl, Sgt and SSgt: Air Mobility Command Affiliation Airlift Load Planner's Course, recertification in:

- (1) Defense Packaging of Hazardous Materials Course (USA) or**
- (2) Transportation of Hazardous Material Course (USN) or**
- (3) Hazardous Materials Preparer Course (USAF) and Inter-modal Dry Cargo Container Reinspection Course.**

²¹ Basic Logistics/Embarkation Specialist Course (BLESC) CDD, CID M0304H7, dated 15 August 2011.

Beyond the contradiction in required training, it is confusing that the majority of all required training is identical for 0431 Cpls, Sgts and SSgts. Here again like the 0411 MOS, there is either no required career training or no differentiation between ranks and required training.

Time in Grade (TIG) and Time in Service (TIS)

From 2002 through 2012, there were 34,940 SSgt allocations open for all MOSs of which 622 were provided to the 0431 MOS (1.87%). Table 7 compares the average TIG and TIS for 0431 SSgt allocations to the average TIG and TIS for all other MOSs with SSgt allocations. (Those cases where the TIG and TIS were not identified were discarded).

Table 7 Average TIG and TIS for 0431 MOS SSgt Allocations

SSGT	MOS	N	M	SD	Std. Error Mean	Range
TIG	0431	622	1.6234	0.5364	0.0215	0.94 - 2.52
	ALL	34318	2.6309	0.8788	0.0047	0.53 - 6.87
TIS	0431	622	6.0671	0.6798	0.0273	5.05 - 7.39
	ALL	31554	7.1901	1.4153	0.0079	2.41 - 20.92

The results of the t test presented in Table 8 indicate that 0431 SSgts required a lower TIG average than what was required for all other MOSs and that the differences were statistically significant ($M = 1.623$, $SD = .5364$) to all other SSgts ($M = 2.631$, $SD = .879$) conditions; $t(682.86) = -45.74$, $p = .000$).

Table 8 Results of the Independent t test for 0431 SSgt

SSGT	F	Sig.	t	df	Sig. (2- tailed)	Mean Dif.	Std. Error Dif.	95% Confidence Interval of the Difference	
								Lower	Upper
0431									
TIG	113.75	0.000	-45.74	682.86	0.000	-1.008	0.022	-1.051	-0.964
TIS	294.69	0.000	-39.54	731.54	0.000	-1.123	0.028	-1.179	-1.067

The average TIS requirements for SSgt were also lower for the 0431 MOS when compared to the required average TIS of all other MOSs and that the difference was also statistically significant ($M = 6.067$, $SD = .6798$) to all other SSgts ($M = 7.19$, $SD = 1.415$) conditions; $t(731.54) = -39.54$, $p = .000$).

The findings indicate that the 0431 MOS requires significantly less experience in grade (over 1 year less) and significantly less time in service (over 1 year less) than other MOSs selecting SSgts during the same time. When a 0431 SSgt is selected for promotion to GySgt, their MOS is changed to 0491 Mobility Chief MOS, which is discussed later in this analysis.

Training and Readiness (T&R) Events

There are twenty-five T&R events for the 0431 MOS; of which five are 1000-level and twenty are 2000-level (Appendix D). All 1000-level T&R events describe the performance requirements for 0431 private through Sgt and all are designated *formal* as an initial training setting; although, curiously only two are included in the entry-level BLESC course.

Of the twenty 2000-level 0431 performance events, 13 are formal learning, six are MOJT, and one is distance learning. The 2000-level T&R events raise multiple questions similar to those found in the 0411

MOS. The primary concern was the lack of differentiation between what is expected and required of vastly different ranks; i.e., private through Sgt, or LCpl up through to captain. For example, "Certify intermodal containers for shipment" and "certify hazardous material for shipment" are required performance events described in the 04XX T&R Manual that 0431 Cpls, Sgts, SSGts, GySgts, warrant officers, chief warrant officers, and captains²² are directed to perform *under the same conditions and to the same performance standard*. A final thought concerning these two unique 0431 T&R events concerns the inclusion of GySgts, warrant officers, chief warrant officers and captains. Each of these ranks has a different MOS - which is not the 0431 MOS. Why then are they included within the 0431 T&R performance events?

There are six 2000-level 0431 T&R events for the ranks of LCpl through SSGt that call for training via MOJT. The obvious question regards standardization of training, specifically, what and how training is administered, evaluated, and recorded. In other words, who has written, approved, and standardized the 0431 MOJT training across the entire 0481 MOS, and what instrument is used to validate training success?

At first glance it appears the 0431 MOS is highly specialized; although, upon review it becomes apparent that many of the 0431 performance standards are very similar to actions performed by other MOSs. For example, comparing the 0431 T&R event - 0431-LOGR-1501: "Prepare supplies and equipment for embarkation" to other ground and

²² The 0431 T&R event "certify hazardous material for shipment" also includes the rank of LCpl.

aviation T&R events reveals many instances of indistinguishable behaviors performed by dissimilar MOSs. Table 9 identifies multiple occupational fields and individual MOSs that perform the same functions as those performed by the 0431 MOS. Additionally, many of these MOSs gain the requisite skill-sets via MOJT; therefore negating the need for formal school attendance and thereby reducing overall training resource requirements such as travel costs, lodging, training facilities, and staffing.

Table 9 MOSs Performing Embarkation Tasks

0369-Platoon Sergeant: Coordinates and supervises the embarkation/debarkation, maintenance, condition, and care of the platoons weapons and equipment including accountability, communication equipment, and if applicable, maintenance, and upkeep of the platoons assigned vehicles. Coordinate and supervises the embarkation and debarkation of his assigned platoon.

0491-OPS-2005: Coordinate amphibious operations (0491, 1371, 3043, 3537)

0491-OPS-2007: Coordinate a unit move (0491, 1371, 3043, 3537)

0811-GUNS-2521: Supervise embarkation (MOJT)

0811-GUNS-2522: Embark marines (MOJT)

2800-ACT-2302: Deploy a field maintenance activity (2823, 2831, 2834, 2862, 2887) (MOJT)

2800-ACT-2305: Prepare organic equipment for embarkation (2821, 2831, 2834, 2844, 2846, 2847, 2862, 2871, 2874, 2887) (MOJT)

2887-OPS-2401: Provide advanced technical assistance during the installation of artillery electronic equipment (MOJT)

2891-OPS-2401; Execute the plan for deployed maintenance

3043-CSS-2001: Manage accountability of unit Maritime Prepositioning Force MPF) assets (SSGT, GYSGT, MSGT, MGYSGT : MOJT)

3043-CSS-2002: Develop supply support plans

3051-FAEQ-1001: Operate material handling equipment (MHE)

3052-FAEQ-1001: Operate automated material handling equipment (MHE)

3112-AITV- 1001: Conduct in-transit visibility (ITV) of cargo

3112-CARG-1101: Process inbound cargo

3112-CARG-1102: Process outbound cargo

3112-CARG-1103: Redistribute cargo

3112-CARG-1105: Conduct container inventory

3112-CARG-1107: Perform rail yard operations

3112-PAXS-1204: Conduct aerial port operations

3112-PPTY-1306: Process an inbound shipment

3529-OPER-2301: Direct the preparation of maintenance support equipment for embarkation (MOJT)

3531-OPER-2207: Prepare motor transport equipment for embarkation (MOJT)

3537-OPER-2303: Prepare maintenance support equipment for embarkation (MOJT)

3537-OPER-2308: Manage vehicle loading operations (MOJT)

5942.01.01 Perform aviation radar system embarkation procedures

5942.01.15 Transport an aviation radar system (MOJT)

5948.01.03 Coordinate aviation radar system embarkation (MOJT)

5952.01.02 Supervise the embarkation of navigational aids equipment (MOJT)

5952.01.03 Embark navigational aids equipment (MOJT)

5953.01.07 Supervise activities in the embarkation of air traffic control radar systems and equipment (MOJT)

5953.01.08 Perform embarkation of air traffic control radar systems & equipment (MOJT)

5954.01.07 Embark MATCALS communication equipment (MOJT)

TANK-EXPD-5601 Prepare for deployment/redeployment

TANK-EXPD-7602: Develop an amphibious landing plan

TANK-EXPD-7603: Plan and conduct a deployment

TANK-EXPD-7606: Conduct an amphibious withdrawal

Formal Training

Per the MOS Manual, an individual need only successfully complete the BLESC to gain the MOS. As such, this equates to mastery of two 1000-level T&R events,²³ "Prepare supplies and equipment for embarkation", and "Use unit move automated information systems (AIS)" (the only two T&R events identified within the BLESC CDD). Upon review of other CSS courses, it quickly became apparent that the BLESC training objectives are very similar to those identified within the MOS-producing 3051 Enlisted Warehouse Specialist Course (EWSC)²⁴ "Perform checkout procedures" and "Operate Radio Frequency Identification (RFID) System". It is also interesting to note that where BLESC trains *two* 0431 T&R events over 19 training days, EWSC trains *thirty-two* 3051 T&R events over a 15 training day timeframe. Although, training goals appear similar, further analysis of the BLESC and EWBC course resource documents does identify many distinct differences between the entry-level training courses (Table 10).

Table 10 BLESC (0431) to EWBC (3051) Course Resource Comparison

Formal School Descriptive Events	BLESC (0431)	EWBC (3051)
Annual Student Throughput	274	579
Course Iterations	7	30
Calendar Days	19	15
Annual Training Days Utilized	133	450
Percent of Annual Training Days Utilized	57%	194%
Number of Instructors	6	9
Number of Support Personnel	11	21

For example, although the number of BLESC instructors is 67% lower in comparison to the EWBC (six instructors instead of nine

²³ (see Footnote 21)

²⁴ Enlisted Warehouse Basic Course (EWBC) CDD CID M03SCM7 dated 6 December 2010.

instructors) the annual number of projected students is more than double (274 compared to 579, respectively). This equates to a BLESC instructor-to-student ratio of one instructor to 46 students compared to the greater one instructor to 64 students' ratio for the EWBC. What becomes apparent upon further analysis is that although the instructor and support staff may be lower for the BLESC (19) than for the EWBC (30), the BLESC only utilizes 58.3 percent (133) of the 228 available training days.²⁵ Conversely, the EWBC requires 450 training days, or 197.4 percent of the available training time, to meet projected student throughput. To resolve this issue, EWBC must increase training day usage over 338.3% than what is required of BLESC, which ultimately requires overlapping classes, balancing resources and classrooms, and meticulously managing instructor and support staff assignments.

A review of multiple CSS T&R manuals also revealed similarities to other ground MOSs, specifically, the 3052, Packaging Specialist "Operate Radio Frequency Identification (RFID) system"; the 3043, Supply Administration and Operations Specialist "Manage the execution of automated supply systems" and the 0481, Basic Landing Support Specialist "Prepare supplies and equipment for throughput operations".

0481 Basic Landing Support Specialist MOS

The 0481 Basic Landing Support Specialist MOS supports the "establishment, maintenance, and control of transportation throughput systems on beaches landing zones, ports (air and sea), and terminals (rail, truck, and container) used in support of MAGTF operations and

²⁵ (see Footnote 19)

deployments" (pg. 3-60). Additionally, the 0481 MOS is tasked with applying automated information systems (AIS) to track the movement of assets throughout the Department of Defense (similar to the 0431 MOS).

MOS Manual

Like the 0411 and 0431 MOSs, the MOS Manual presents conflicting training requirements for the 0481 MOS. Page 3-61 of the MOS Manual (Appendix E) requires only the entry-level, MOS-producing Basic Landing Support Specialist Course (BLSSC)²⁶ while pages 3-66 through 3-82 do not require any training before the rank of corporal - to include successful completion of the 0431 MOS-generating, entry-level BLSSC. In addition, while this contradiction is confusing, what is more disturbing is that the majority of required training for 0481 Cpls through SSgts is identical to that required of the 0431 MOS - less two deviations concerning professional military education (PME) not exclusive to the 0481 MOS. Table 11 lists the required training as specified by the MOS Manual.

²⁶ Basic Landing Support Specialist Course (BLSSC) CID M0313I7 dated 15 August 2011.

Table 11 Comparison of MOS Manual Required Formal Training

0481 SSgt	0431 SSgt
Advanced Logistics/Mobility Course	Advanced Logistics/Mobility Course
Air Mobility Command Affiliation Airlift Load Planner's Course	Air Mobility Command Affiliation Airlift Load Planner's Course
Recertification in:	Recertification in:
(1) Defense Packaging of Hazardous Materials Course (USA) or	(1) Defense Packaging of Hazardous Materials Course (USA) or
(2) Transportation of Hazardous Material Course (USN) or	(2) Transportation of Hazardous Material Course (USN) or
(3) Hazardous Materials Preparer Course (USAF)	(3) Hazardous Materials Preparer Course (USAF)
Inter-modal Dry Cargo Container Reinspection Course	Inter-modal Dry Cargo Container Reinspection Course
*MCI 8100 Staff NCO Career Distance Education Program	
0481 Sgt	0431 Sgt
*Landing Support NCO Course	*Logistics/Embarkation NCO Course
Air Mobility Command Affiliation Airlift Load Planner's Course	Air Mobility Command Affiliation Airlift Load Planners Course
Recertification in:	Certification in:
(1) Defense Packaging of Hazardous Materials Course (USA) or	(1) Defense Packaging of Hazardous Materials Course (USA) or
(2) Transportation of Hazardous Material Course (USN) or	(2) Transportation of Hazardous Materials Course (USN) or
(3) Hazardous Materials Preparer Course (USAF)	(3) Hazardous Materials Preparer Course (USAF)
Inter-modal Dry Cargo Container Reinspection Course	Inter-modal Dry Cargo Container Reinspection Course
*MCI 8100 Sergeants Distance Education Program	
0481 Cpl	0431 Cpl
*Landing Support NCO Course	*Logistics/Embarkation NCO Course
Air Mobility Command Affiliation Airlift Load Planner's Course	Air Mobility Command Affiliation Airlift Load Planners Course
Recertification in:	Certification in:
(1) Defense Packaging of Hazardous Materials Course (USA) or	(1) Defense Packaging of Hazardous Materials Course (USA) or
(2) Transportation of Hazardous Material Course (USN) or	(2) Transportation of Hazardous Materials Course (USN) or
(3) Hazardous Materials Preparer Course (USAF)	(3) Hazardous Materials Preparer Course (USAF)
Inter-modal Dry Cargo Container Reinspection Course	Inter-modal Dry Cargo Container Reinspection Course
0481 LCpl	0431 LCpl
*Required Training: None	*Basic Logistics/Embarkation Specialist Course
0481 PFC	0431 PFC
*Required Training: None	*Basic Logistics/Embarkation Specialist Course
0481 Pvt	0431 Pvt
*Required Training: None	*Basic Logistics/Embarkation Specialist Course

It is difficult to explain or rationalize how two supposedly different MOSs can assign identical training requirement, especially when the MOS Manual is annually reviewed. Incidentally, although the MOS Manual directs lateral-move sergeants to attend the Logistics/Embarkation NCO Course, no exclusive 0481 NCO course currently exists. What does exist is an Intermediate Landing Support Course (ILSC) developed for 0481 Cpls through SSgt, although the MOS Manual has yet to identify the course as mandatory for 0481 NCOs or SNCOs.

Time in Grade (TIG) and Time in Service (TIS)

From 2002 through 2012, there were 34,940 SSgt allocations in all MOSs of which 281 were allocated for the 0481 MOS (.80%). Table 12 reports the average 0481 SSgt TIG and TIS to the average TIG and TIS for all other MOSs with SSgt allocations. (Those cases where the TIG and TIS were not identified were discarded). The findings indicate that the 0481 SSgt required less TIG (.7 years) and less TIS (.81 years) on average than other MOSs selecting SSgts during the same time.

Table 12 Average TIG and TIS for 0481 MOS SSgt Allocations

SSGT	MOS	N	M	SD	Std. Error Mean	Range
TIG	0481	281	1.9109	0.4743	0.0283	1.28 - 2.84
	ALL	34659	2.6187	0.8843	0.0048	0.53 - 6.87
TIS	0481	227	6.3641	0.8527	0.0566	4.69 - 8.01
	ALL	31949	7.1741	1.4148	0.0079	2.41 - 20.92

The results of the t test presented in Table 13 indicate that 0481 SSgts required a lower average TIG than SSgts (meaning less time as a sergeant) from all other MOSs and that the differences were

statistically significant (M = 1.911, SD = .4743) to all other SSgts (M = 2.619, SD = .8843) conditions; $t(296.004) = -24.67$, $p = .000$).

Table 13 Results of the Independent t test for 0411 SSgt

SSGT	F	Sig.	t	df	Sig. (2-tailed)	Mean Dif.	Std. Error Dif.	95% Confidence Interval of the Difference	
								Lower	Upper
0481									
TIG	136.99	.000	-24.67	296.00	0.000	-0.708	0.029	-0.76	-0.651
TIS	69.561	.000	-14.17	234.93	0.000	-0.810	0.057	-0.923	-0.697

The average TIS requirements for SSgt were also lower for the 0481 MOS when compared to SSgts from other MOSs, and that the differences were also statistically significant (M = 6.364, SD = .8527) to all other SSgts (M = 7.174, SD = 1.415) conditions; $t(234.926) = -14.17$, $p = .000$).

For selection to SSgt, the 0481 MOS did require significantly less experience in grade (8 months, 19 days) and significantly less time in service (9 months, 25 days) on average than other MOSs selecting SSgts during the same time. SSgts in the 0481 MOS are also assigned the 0491 Mobility Chief MOS when selected for promotion to GySgt; therefore, data for GySgt are not reported here.

Training and Readiness (T&R) Events

Concerns similar to the 0431 and 0411 MOS are readily apparent upon review of the 0481 MOS. Appendix F identifies the five 1000-level and eight 2000-level T&R events prescribed to the 0481 MOS. All are specified formal school setting. As previously discussed in other 04XX MOSs, the 0481 1000-level T&R events assign identical performance behaviors *with the same conditions and performance standards* to entry-level privates through SSgts (one event stops at Sgt), while 0481

2000-level T&R events do the same with for Cpls through SSgt (with one exclusive to SSgt). This lack of role differentiation presents an image of an MOS where all behaviors are performed - and evaluated - equally by all ranks, which remains implausible in any military hierarchy.

Formal Training

Historically, 0481 MOS training (beyond the entry-level, MOS-producing course) has shown to have been haphazard at best. As far back as 1988, the 0481 MOS trained side-by-side with the 0431 MOS, initially in the Logistics/Embarkation SNCO/NCO Course (LEC), then the Logistics/Embarkation Career Course (LECC) (approved in 2001), and then again in the Logistics Embarkation NCO Course (LENCO) (approved in 2006). In 2009, the Intermediate Landing Support Course (ILSC) was developed exclusively for 0481 Cpls through SSgts; although, it has yet to be reflected in the annually reviewed MOS Manual. It is also interesting to note that even though the management of all 0481 MOS training was assigned to Marine Corps Combat Service Support Schools (MCCSSS) well before 2000, the annually reviewed MOS Manual failed to reflect the change from Marine Corps Engineer School until after 2006.

The MOS-generating, entry-level BLSSC identifies four instructor staff personnel (1-GySgt and 3-Sgts) necessary to train nine, 25-training day classes for 360 programmed students annually; thereby, utilizing 98.7% (225) of the 228 available training days.²⁷

What is more curious is that - although similar - none of the current 1000-level 0481 T&R events match the terminal learning

²⁷ (see Footnote 19)

objectives identified in the BLSSC resource documents (Table 14).

This is unusual because MCO 1553.2B, Management of Marine Corps Formal Schools and Training Detachments mandates the development of terminal learning objectives exclusively from MOS T&R events.²⁸

Table 14 BLSSC Learning Objectives to 0481 1000-level T&R Events

Basic Landing Support Specialist Course (BLSSC)	0481 T&R Manual
0481-ADMN-1001 Utilize automated information systems (AIS) in support of throughput operations	
0481-ADMN-1002 Perform In-Transit Visibility (ITV) Asset Tracking Functions	
0481-LOAD-1401 Execute helicopter support team (HST) operations	0481-OPS-1401: Conduct helicopter support team (HST) operations
0481-LOAD-1402 Load vehicles and cargo on rail cars	0481-OPS-1402: Conduct rail operations
0481-OPS-1701 Execute amphibious landing support operations	0481-OPS-1404: Conduct beach operations
0481-OPS-1702 Execute Air Terminal Operations	
0481-OPS-1703 Execute Sea Terminal Operations	0481-OPS-1403: Conduct port operations
0481-OPS-1704 Prepare supplies and equipment for throughput operations	0481-OPS-1405: Conduct arrival airfield control group/departure airfield control group (A/DACG) operations

Reviewing the 0481 T&R events reveal obvious similarities to the 3043 Supply Administration and Operations Specialist MOS that include: Radio Frequency Identification Devices (RFIDs), shipping manifests, inventories, Material Handling Equipment (MHE), containerization, and loading and storing items within specified areas. Additionally, there were noticeable similarities to the 3051 MOS T&Rs to include, operate Material Handling Equipment(MHE), prepare sub-custody receipt, perform check in/out procedures, prepare individual issue form, issue supplies

²⁸ MCO 1553.2B, Management of Marine Corps Formal Schools and Training Detachments dated 1 April 2011 mandates use of the Marine Corps Training Information Management System (MCTIMS) Curriculum Management Module. MCTIMS is used to create and document course design and development from receipt of T&R events (which become learning objectives) through final acceptance of the Program of Instruction (POI).

and equipment, perform location consolidation, perform inventory procedures, maintain documents, process equipment, safeguard personal effects, maintain hazardous material, and perform outdoor storage procedures. The only real and substantial differences noted in the T&R Manual for the 0481 and not for the 3043 or 3051 are Port Operations (Annex D, 10 hours of the BLSSC), Beach Support (Annex E, 17.5 hours of the BLSSC), and External Life/Helicopter Support Teams (HSTs)(Annex F, 52.5 hours of the BLSSC). Although these are significant 'learning material' differences, the fact remains that without those differences - a total of 80 hours - the 0481 T&R events are quite similar to T&R events found within both the 3043 Supply Administration MOS and the 3051 Enlisted Warehousing MOS.

0491, Logistics/Mobility Chief MOS

The final enlisted MOS critically examined was the 0491 Logistics/Mobility Chief MOS. Currently, the 0491 MOS is the career progression product of two previously discussed and distinctly different MOSs, the *0431 Logistics/Embarkation MOS* which is tasked to prepare supplies and equipment for embarkation and performs various Force Deployment Planning and Execution (FDP&E) functions to support the movement of personnel, supplies, and equipment via all modes of transportation using commercial and military assets, at all levels including unit, MAGTF, and joint operations, and the *0481 Landing Service Support MOS* which is tasked to perform various duties that support the establishment, maintenance and control of transportation throughput systems on beaches, landing zones, ports (air and sea), and terminals (rail, truck, and container) used in support of MAGTF

operations and deployments. It is also interesting to note that until 2006²⁹ the 0451 Parachute Rigger was also a feeder MOS to the 0491 MOS.

MOS Manual

The MOS Manual (Appendix G) describes the newly promoted 0491 GySgt as accountable for all unit level logistics and embarkation training, but more importantly they are also responsible to "articulate command strategic mobility requirements both present and future to appropriate agencies, such as; Headquarters Marine Corps, U.S. Transportation Command and her three Transportation Component Commands (TCCs); Surface Deployment Distribution Command, Military Sealift Command, and Air Mobility Command" (pg. 3-61). With this level of responsibility assigned to the 0491 MOS, an honest assessor must question the logic of combining two very dissimilar MOSs into a single senior enlisted MOS.

The MOS Manual identifies the required 0491 MOS training as successful completion of the 15-training day, Advanced Logistics/Mobility Chiefs (ALMC) course.³⁰ However, like the 0411, 0431 and 0481 MOSs, the MOS Manual presents conflicting training requirements for the 0491 MOS. Page 3-61 of the MOS Manual requires only the Advanced Logistics/Mobility Course for GySgts or SSgts (presumably from the 0431 or 0481 MOSs) while pages 3-83 through 3-85 indicate additional training for the 0491 GySgt that is identical to what is required of both 0431 and 0481 SSgts, less one MCI 8200-Staff NCO Advanced Distance Education Program.³¹ The MOS Manual does not

²⁹ Marine Corps Bulletin 1200, MOS Manual dated 15 May 2006.

³⁰ Advanced Logistics/Mobility Chiefs (ALMC) course CID M03LBC7 dated 29 May 2009.

³¹ Professional Military Education (PME) is not exclusive to the 0491 MOS.

identify any required MOS sustainment training for MSgts or MGySgts in the 0491 MOS.

Time in Grade (TIG) and Time in Service (TIS)

From 2003 through 2012 there were 16,665 GySgt allocations for all MOSs of which 481 were given to the 0491 MOS (2.89%). Table 15 compares the average TIG and TIS for 0491 GySgt allocations to the average TIG and TIS for all other MOSs with GySgt allocations. (Those cases where the TIG and TIS were not identified were discarded).

Table 15 Average TIG and TIS for 0491 GySgt Allocations

GYSGT	MOS	N	M	SD	Std. Error Mean	Range
TIG	0491	481	1.9062	0.4584	0.0209	1.28 - 2.76
	ALL	16175	2.9501	0.9222	0.0073	1.20 - 7.77
TIS	0491	405	7.7985	1.2002	0.0596	5.77 - 10.14
	ALL	14833	8.4798	1.4273	0.0117	3.79 - 13.73

The results of the independent t test shown in Table 16 show that 0491 GySgts required a lower average TIG (less time as either a 0431 or 0481 SSgt) than all other MOSs and that the differences were statistically significant (M = 1.906, SD = .4584) to all other MOSs (M = 2.9501, SD = .9222) conditions; $t(602.233) = -47.186$, $p = .000$).

Table 16 Results of the Independent t test for 0491 GySgt

GYSGT	F	Sig.	t	df	Sig. (2-tailed)	Mean Dif.	Std. Error Dif.	95% Confidence Interval of the Difference	
0491								Lower	Upper
TIG	213.36	0.000	-47.186	602.23	0.000	-1.044	0.022	-1.087	-1.001
TIS	8.51	0.004	-11.209	435.79	0.000	-0.681	0.061	-0.801	-0.562

The 0491 MOS also set a lower average TIS requirement for GySgts (less time in service) than what was required of all other MOSs, and that the difference was also statistically significant (M = 7.799, SD

= .1.200) to all other MOS (M = 8.479, SD = 1.428) conditions;
t(435.785)= -11.209, p = .000).

Although difficult to explain, as a product of two distinctly unique MOSs for selection to GySgt, the 0491 MOS requires significantly less time in grade (over 1 year) and significantly less time in service (8 months, 9 days) than all other MOSs selected during the same time.

Training and Readiness (T&R) Events

As discussed previously, the duties and responsibilities performed by the 0431 and 0481 are quite diverse. A review of the 04XX T&R Manual explicitly identifies 0431 MOS billets exclusively as Embarkation NCO, Embarkation Chief, Team Embarkation Assistant, Team Embarkation Officer, and Combat Cargo Assistant (at SSgt). While Logistics NCO and Logistics Chief are also included, there is *no mention of Landing Support Specialist duties or functions.*

Conversely, the 0481 MOS identifies billets that are exclusively Landing Support Specialist or Logistics Chief (at SSgt) with *no mention of any associated embarkation related duties or functions.*

Appendix H identifies the eleven 2000-level events required to achieve and maintain 0491 MOS competency. All are specified formal school setting (although there is not currently a senior enlisted 0491 MOS formal course) and all report the T&R events as required for the specific billets of Logistics Chief, Operations Chief, and Plans Chief. Like the 0411, 0431, and 0481 MOSs, the 0491 MOS T&R events assign identical performance behaviors - with *the same conditions and performance standards* - to GySgts, MSgts, and MGySgts.

Formal Training

In an attempt to rectify any potential MOS training - and ultimately performance - deficiencies, the occupational field sponsor, in collaboration with senior enlisted field representation, directed all 0491s successfully complete standardized formal school training. This is one time where an entire MOS was thought to consider "formal standardized training" essential to an individual's success in areas where they may not be particularly competent or confident. Unfortunately, a review of the last 10-years of promotion and school attendance data demonstrates that mandatory attendance has not been the case. Table 17 shows that of the 518 SSgts promoted to 0491 GySgt since 2002, barely one-third (35.71%) have attended the MOS Manual directed requisite formal training in either the Combat Service Support Chiefs (CSSC)³² course or the Advanced Logistics Mobility Chiefs (ALMC) course.

³² The 32-training day Combat Service Support Chiefs (CSSC) course was discontinued in 2006.

Table 17 0491 MOS Promotions to Formal School Attendance

Year	Course Title (M03LBC7)	n = SSgts Promoted to GySgt	n = Available Formal School Seats	n = Formal School Graduates	% Grads to Formal School Seats	% of Promotions Formal School Graduates
FY02	CSSC	53	86	23	26.74%	43.40%
FY03	CSSC	50	83	13	15.66%	26.00%
FY04	CSSC	28	89	34	38.20%	121.43%
FY05	CSSC	48	72	28	38.89%	58.33%
FY06	CSSC	42	76	19	25.00%	45.24%
FY07	ALMC	77	75	18	24.00%	23.38%
FY08	ALMC	67	80	6	7.50%	8.96%
FY09	ALMC	45	60	30	50.00%	66.67%
FY10	ALMC	56	60	14	23.33%	25.00%
FY11	ALMC	52	60	0	0.00%	0.00%
FY02-11	N	518	741	185	24.97%	35.71%

Additionally, the findings demonstrate that of the 741 formal school seats reserved since 2002, only 185 students graduated equally less than a quarter (24.97%) of the seats being filled. This indicates that over the last ten years - for every formerly trained 0491 there were two 0491s that were not (64.29%) - even though training was mandated - by Marine Corps Order - upon promotion to 0491 GySgt.

There is one final note concerning formal training for the 0491 MOS. If every 0491 GySgt selected in 2013 were to decide to attend the mandatory formal school training, attendance would be impossible as the ALMC course was cancelled for the entire FY11 academic year, and subsequently deactivated completely in FY12. Currently, there is no MOS-awarding or sustaining formal training opportunity for the 0491 MOS.

0430 Mobility Officer MOS

This section examines the 0430 Mobility Officer MOS; that is, the warrant officer, chief warrant officer, and limited duty officer ranks. Warrant officers and limited duty officers (LDOs) bridge the gap between the enlisted and officer ranks as the occupational field's "technical specialist who performs duties that require extensive knowledge, training, and experience with systems or equipment which are beyond the duties of staff non-commissioned and unrestricted officers" (Pfister, 2000). To understand the 0430 MOS, it is necessary to define the warrant officer ranks and selection process.

Headquarters Marine Corps publishes administrative instructions annually for warrant officer selection boards based on projected MOS vacancies and subsequent quotas. Enlisted applicants may voluntarily submit a selection package for consideration to warrant officer (or chief warrant officers may seek LDO selection) in compliance with selection board requirements of rank, years of service, and age restrictions. After meeting the minimum requirements of either an EL score of 110 on the Armed Service Vocational Aptitude Battery (ASVAB), a combined Scholastic Achievement Test (SAT)³³ score of 1000 (math and verbal), or a combined American College Test (ACT) composite score of 22, the applicant's commanding officer must provide supporting justification addressing the applicant's technical proficiency of the MOS they have selected for consideration.

³³ Per MCBul 1040 Fiscal Year 2013 (FY13) Enlisted to Warrant Officer (WO) Regular Selection Board, MARADMIN 034/12, signed 17 January 2012.

Warrant officers hold appointments from the Secretary of the Navy and receive presidential commissions when promoted to chief warrant officer. WOs are promoted to CW02 based on TIG requirements found in section 573 of Title 10, U.S. Code and as determined by the Secretary of the Navy under SECNAVINST 1412.9B. Promotion is linear from warrant officer to chief warrant officer-2, -3, -4, and -5 depending on MOS vacancies and subsequent quotas.

Additionally, CWOs can be considered for restricted Limited Duty Officer (LDO) to serve as captains, majors, and lieutenant colonels. LDOs secure appointments as regular officers for the "performance of duty in the technical field in which they are proficient" and are expected to be "technically oriented" to "perform duties that are limited to specific occupational fields, and do not have the normal career pattern of unrestricted officers" to "compete within their MOS among other LDOs of the "same grade for promotions to major and lieutenant colonel via selection boards".³⁴

The warrant officer is the junior-most grade of the warrant officer ranks having recently been selected from a pool of enlisted personnel from a variety of "feeder" MOSs, which are entry-level enlisted MOSs attained before selection to warrant officer. Although most warrant officer MOSs are directly linked to a specific feeder MOS - where critical skill sets have been progressively monitored and carefully nurtured to ensure mastery - an applicant may apply for any

³⁴ MCO P1100.73B, Military personnel procurement manual, volume 3, officer procurement dated 29 September 1989, pg. 2-25.

MOS regardless of the occupational specialty they are currently performing.

Warrant officers are often considered specialists and subject experts regarding military technologies or capabilities particularly in highly technical (aviation, electronics, information/data-management, etc.) or operationally specific (infantry, engineering, utilities, etc.) fields. As such, warrant officers often serve as the principal technical experts in their MOS, responsible and capable of advising and/or leading their respective MOS into the future.

MOS Manual

The MOS Manual (Appendix I) describes the functions of the 0430 MOS as "Mobility officers plan and execute unit movements of personnel, supplies, and equipment via all modes of transportation. They prepare and execute deployment plans to deploy and sustain Marine combat forces of a MAGTF, joint task, or as a member of a component command. They serve as mobility officers at the regiment, aircraft group, separate battalion, MEU, MarDiv, MAW, and MLG Level; MWSS, CLB, Aircraft Group, and as a Strategic Mobility Officer at the Combatant Command, Joint Task Force, MEF, and MARFOR levels. They also serve as Combat Cargo Officers (CCOs) on Naval staffs and amphibious ships. Moreover, they coordinate and conduct unit-level embarkation and mobility training, and they are assigned as Embarkation and Strategic Mobility Instructors at Logistics Operations School, Marine Corps Combat Service Support Schools (MCCSSS) and Expeditionary Warfare Training Group Pacific (ETWGPAC). Mobility officers analyze,

translate, and execute commander's operational requirements and intent to support mission requirements" (pg. 1-21).

Analyzing the 0430 MOS was made particularly difficult due to the multiple factors that contribute to the complexity of the MOS beyond what is described in the MOS Manual. Therefore, by using the MOS Manual's description that the 0430 "MOS is technical in nature and requires years of **training, education, and experience** to become proficient" a focused approach could be fomented to analyze the MOS as a whole. As such, the examination of the elements of training and education was assisted with data obtained from formal school records and post-secondary education levels - as identified in promotion board results. Accordingly, the 0430 MOS element of experience was analyzed as a composite of initial enlisted feeder MOS, and comparative TIS, TIG and age of MOSs performing similar functions.

The first component of the MOS Manual's description of the 0430 MOS is **years of training** referring specifically to mandatory formal school training necessary to gain or sustain the MOS. What is most curious about the 0430 MOS's mandatory training is the blatant paucity of formal training required. Even though the MOS Manual *recommends* numerous skill progression courses that a 0430 MOS could attend to gain proficiency, there is but one formal course requirement for newly selected warrant officers - completion of the Mobility Officer Course (MOC).³⁵ Even more confusing is that the MOC is only required for 0430 warrant officers if they had not previously completed the course as an enlisted Marine. The scarcity of required training appears at odds

³⁵ Mobility Officer Course (MOC) CID M03H347 dated 16 August 2011.

with the MOS Manual's description of 0430 mobility officer's being "subject matter experts (SME)" who "provide interface and articulate the strategic mobility requirements both present and future to appropriate agencies, such as, Headquarters Marine Corps, U.S. Transportation Command and her three Transportation Component Commands (TCCs); Surface Deployment Distribution Command, Military Sealift Command, and Air Mobility Command" (pg. 1-21).

Although improbably, it could be that the 17-training day formal MOC is sufficient to meet the training needs of newly selected 0430 warrant officers - as long as they successively graduate from the course. Unfortunately, upon review of seven years of graduation records, it appears that - like the 0491 MOS - the mandatory training for the 0430 warrant officer was also not attended as directed by the MOS Manual.

Formal School Training

In 2005, the required formal school training for newly selected warrant officers was attendance to the Logistics/Embarkation Career Course (LECC)³⁶ surprisingly, the same course required of staff noncommissioned officers. Out of the 49 LECC graduates, only four were 0430 warrant officers, accounting for 26.7 percent of the 15 0430 warrant officers selected in 2005. There were eleven 0430 warrant officers selected in 2006 and 43 formal school graduates, of which six were 0430 warrant officers (54.5%). There was also one 0430 CW02 graduate which increased the 0430 MOS attendance percentage to 63.6% when combined with the 0430 warrant officers. Although, there were

³⁶ Logistics/Embarkation Career Course (LECC) CID M03LAM07.

nine 0430 warrant officers selected in 2007, there were no 0430 MOS graduates in the 39 Logistics Embarkation NCO (LENCO) course formal school graduates (0%). In 2008, the MOS Manual³⁷ directed 0430 warrant officers to attend the Mobility Officer Course (MOC) as a condition for selection to warrant officer. There were 16 0430 warrant officers selected in 2008 and 14 0430 MOS graduates from the formal school (87.5%). There were 16 0430 warrant officers selected in 2009 and 15 0430 graduates from the required formal school (93.8%); however, in 2010 there were only 19 0430 MOS graduates compared to the 22 0430 warrant officer selections (86.4%). In 2011 and 2012, 0430 MOS graduates exceeded or met 0430 warrant officer selections with 17 0430 graduates to 14 0430 warrant officer selections (121.4%) in 2011, and eight 0430 graduates to eight 0430 warrant officer selections (100%).

Table 18 reports the percent and number of 0430 warrant officers selections to the number of 0430 MOS graduates for fiscal years (FY) 2005 through 2012. Additionally, the 0430 MOS Training Input Plan (TIP) programmed formal school quotas, course graduates (including 0430 MOS graduates), and percentiles are shown to demonstrate resource utilization. As the LECC and LENCO courses combined different MOSS into a single training population to determine class allocations; e.g., LECC combined the 0431, 0481, 0491 and 0430 MOSS, TIP quotas and class seat allocations are reported in columns 4 and 5.

For the years 2005 through 2012, the 0430 MOS met 74.8% of their mandatory formal school training (111 selectees with 83 graduates) but only by combining warrant officers with CW02s - even though the MOS

³⁷ MCO 1200.17, MOS Manual dated 23 May 2008.

Manual directed completion of required training upon selection to 0430 warrant officer.

Table 18 0430 MOS Selection and Attendance to Formal Training

	0430 Selected	FLC Grads (% Trained)	0430 TIP (% Graduate)	FLC Seats/ Grads (% Graduate)
LECC FY05	15	4 (26.7%)	18 (22.2%)	120/49 (40.8%)
LECC FY06	11	6 (54.5%)	12 (50.0%)	90/43 (47.8%)
LENCO FY07	9	0 (00.0%)	7 (00.0%)	120/38 (31.7%)
LENCO FY08 ³⁸	16	14 (87.5%)	18 (77.8%)	120/38 (31.7%)
LENCO FY09	16	15 (93.9%)	46 (30.4%)	150/52 (34.7%)
MOC FY10	22	19 (86.4%)	24 (79.2%)	30/21 (70.0%)
MOC FY11	14	17 (121.4%)	22 (77.3%)	30/20 (66.7%)
MOC FY12	8	9 100.0%)	14 (57.1%)	30/9 (30.0%)
Total	111	83 (74.8%)	161 (50.9%)	690/270 (39.1%)

Of the 161 0430 MOS students programmed to attend mandatory training as reported in the annual TIP, only 50.9 percent successfully graduated from the formal school. Additionally, each year the formal school identifies the required number of school seats set aside to meet the MOS TIP quotas, which therefore, cannot be utilized by other courses. In the case of the 0430 MOS, there were 690 seats reserved to train LECC, LENCO, and MOC students; although, only 39.1 percent of classroom quotas were filled to produce 270 graduates.

The MOC CDD identifies five instructor staff personnel (1-Major, 1-Captain, 1-CWO-3, 1-MSgt, and 1-GS9) as required to train 15 students annually programmed in the TIP. Seven support staff personnel are also identified as minimally required (1% to 34% of workday) to support the administration and operation of personnel, students, and facilities. The MOC is taught one time per year for 17-

³⁸ Although the Mobility Officer Course (MOC)(CID M03H347) was implemented during 2008, it was not programmed in the 2008 or 2009 Training Input Plan (TIP); therefore, the LENCO (CID M03LAM7) TIP planning numbers were utilized with the MOC 0430 graduation numbers.

days equating to only 7.46 percent of the 228 available training days³⁹ being utilized to train MOC students. This also means that for over 11-months out of each year, the five instructor staff personnel assigned to train students are not.

Training and Readiness (T&R) Events

The 0430 T&R performance events directly affect the 0430 MOS training requirements. Appendix J displays the twenty-five 0430 mobility officer T&R events as shown in the 04XX T&R Manual.

Like the other 04XX MOSs analyzed, the 0430 MOS assigns identical behaviors to very dissimilar ranks supposedly holding different billets with varying levels of responsibility and accountability. For example T&R event *0430-LOGR-2101: Manage unit embarkation inspection program*, is identified as a required T&R event for 0430 warrant officers, CWOs, and LDO captains, majors and LtCols. The training condition 'Given AIS data, personnel and equipment, unit to be inspected, and references' as well as the training standard 'IAW MCRP 4-11.3 Unit Embarkation Handbook' are the same regardless of rank. Additionally, the six performance steps 'establish inspection schedule, validate unit personnel training report, validate AIS data, supervise inspections, report inspection results, and ensure corrective action taken' are also identical for all individuals in the 0430 MOS, regardless of rank.

Education

The second component of the MOS Manual's description of the 0430 MOS is **years of education** specifically referring to post-secondary

³⁹ (see Footnote 19)

education; i.e., self-directed, lifelong, accredited, adult learning and not formal MOS-specific training. Although, education is not a defining consideration for selection to the warrant officer ranks (as it is for entry-level 2nd Lieutenants), seeking out and earning credentials beyond the secondary level demonstrates notable initiative and portrays a clear indication of individual growth and personal advancement.

Appendix K displays the warrant officer, chief warrant officer, and LDO major and LtCol education data for selection years 2005 through 2011 (education data was not available for 2012 or 2013). Post-board selection data for warrant officers and CWO-2s were not available for this analysis; therefore, data drawn from the current 2012 Manpower Report was used instead.

Of the 205 active-duty warrant officers currently serving in October 2012, seven are in the 0430 MOS (3.48%). One-hundred forty-seven warrant officers (73.13%) report their highest educational level as 12th grade⁴⁰ and 29 (14.43%) report some college. Twenty-two warrant officers (10.94%) report earning either a four- or six-year degree. By comparison, six of seven 0430 warrant officers (85.71%) report their highest education level as a 12th grade, 12.58 percent higher than that of all warrant officers. Table 19 reveals that a single 0430 warrant officer (14.28%) completed a two-year degree - the only post-secondary education attained beyond the minimum education requirement necessary for selection to warrant officer or initial enlistment. Table 19 also reports the education level of the 945

⁴⁰ The education level of three warrant officers (1.49%) was identified as unknown.

active-duty CWO-2s currently serving (as of October 2012) in the U.S. Marine Corps of which 50 are in the 0430 MOS (5.45%).

Table 19 Educational Level of Active-duty Warrant Officers & Chief Warrant Officers

Rank	MOS	HSE		AA		BA or Above		Total	
		n	%	n	%	n	%	N	%
WO	0430	6	85.71%	1	14.28%	0	0.00%	7	3.41%
	ALL MOSSs	147	73.13%	29	14.43%	22	11.11%	198	96.58%
	N	153	74.63%	30	14.63%	22	10.73%	205	100.00%
CWO2	0430	43	86.00%	5	10.00%	2	4.00%	50	5.29%
	ALL MOSSs	633	69.03%	145	15.81%	117	12.76%	917	97.03%
	N	676	71.53%	150	15.87%	119	12.59%	945	100.00%
CWO3	0430	43	82.70%	8	15.40%	1	1.92%	52	5.30%
	ALL MOSSs	732	79.20%	101	10.90%	91	9.85%	924	94.70%
	N	775	79.40%	109	11.20%	92	9.43%	976	100.00%
CWO4	0430	13	86.70%	2	13.30%	0	0.00%	15	3.50%
	ALL MOSSs	275	67.76%	51	12.40%	84	20.49%	410	96.50%
	N	288	67.80%	53	12.50%	84	19.76%	425	100.00%
CWO5	0430	3	60.00%	0	0.00%	2	40.00%	5	4.50%
	ALL MOSSs	64	61.00%	13	12.40%	28	26.67%	105	95.50%
	N	67	60.90%	13	11.80%	30	27.27%	110	100.00%
CWO3-5	0430	59	81.90%	10	13.90%	3	4.17%	72	4.80%
	ALL MOSSs	1071	74.40%	165	11.50%	203	14.11%	1439	95.20%
	N	1130	74.80%	175	11.60%	206	13.63%	1511	100.00%

Forty-three 0430 CWO-2s (86.0%) reported the 12th grade as their highest level of education, which is 16.97 percent higher than the 69.03 percent reported by 633 of their peers in other MOSSs.⁴¹ There were 145 CWO-2s (15.81%) in all MOSSs that reported some college, compared to the five 0430 CWO-2s (10.0%) that reported the same. One-hundred seventeen CWO-2s from all MOS (12.76%) reported four years or more of education compared to only two 0430 CWO-2s (4.0%) with the same. Finally, no 0430 CWO-2 reported earning any graduate level education.

⁴¹ The education level of 22 CWO2s (2.39%) was not available during data collection.

The education levels of all CWO-3s selected in 2006 through 2010 is reported in Table 19. Of the 976 CWO-3s selected, 52 were from the 0430 MOS (5.30%). Forty-three 0430 CWO-3s (82.69%) reported their highest education level as the 12th grade - 3.49 percent higher than the 732 CWO-3s (79.2%) from all MOSs that reported the same. Eight 0430 CWO-3s (15.40%) reported two-years of post-secondary education - 4.5 percent higher than the 10.9 percent reported by all CWO-3s from other MOSs. Ninety-one CWO-3s (9.80%) from all MOSs reported having a four- or six-year degree, compared to only a single 0430 CWO-3s with a four-year degree (1.90%). No 0430 CWO-3 earned any graduate-level education.

Of the 425 CWO-4s selected in 2006 through 2010, 15 were from the 0430 MOS (3.5%), as shown in Table 19. Thirteen 0430 CWO-4s (86.67%) reported the 12th grade as their highest educational level, 18.91 percent higher than the 67.76 percent reported by the 275 CWO-4s selected from all MOSs. Overall, there were 53 two-year degrees (12.50%), 62 four-year degrees (14.60%) and 22 six-year degrees (5.20%) reported by all CWO-4 MOSs; whereas, the 0430 CWO-4 reported only two two-year degrees (13.33%) and no four-year or six-year degrees (0.0%).

The education levels of all CWO-5s selected in 2006, 2007, 2009 and 2010 (2008 was excluded due to missing data) is displayed in Table 19. Of the 110 CWO-5s selected, five were from the 0430 MOS (4.5%). Three 0430 CWO-5s (60.00%) reported the 12th grade as their highest education level, which is comparable to the 60.91 percent average reported by the other 64 CWO-5s from all MOSs. Unfortunately, this

indicates that forty percent of all CWO-5s received no post-secondary education in the years prior to, or since selection to warrant officer. Surprisingly, the 0430 CWO-5 exceeded the average percent of four- and six-year degrees (40.0%) compared to the 26.60% attained by all CWO-5s; although, the low number of CWO-5 identified (n = 5) could certainly have skewed the results.

The education levels of all CWO3-5s selected in 2006 through 2010⁴² were combined as reported in Table 19. When combined there were 1511 CWO3-5s in all MOSs while 72 were from the 0430 MOS (4.80%). It is not surprising that the 0430 MOS had the highest percentage of individuals reporting the 12th grade as the highest educational level attained (81.90%) and the second highest percentage of two-year degrees (13.90%). Conversely, the 0430 MOS reported the lowest percentage of four-year (2.80%) and six-year degrees (1.40%). As such, only 13 of 72 0430 CWO3-5s (18.06%) attained any post-secondary education beyond the minimum required for warrant officer selection - 7.51 percent less than the 25.57 percent attained by CWO3-5 from all other MOSs.

To reemphasize, higher education is not a prerequisite for selection or promotion, although, it does exemplify an individual's desire to increase their overall practical knowledge of the world around them. That an education disparity exists in the warrant officer ranks becomes most evident when the 0430 MOS is compared to other CSS MOSs that serve in similar environments and deploy on the same schedule. To demonstrate this imbalance, Table 20 compares the

⁴² The CWO-5 2008 education level data was unobtainable for analysis.

0430 MOS to four-associated CSS MOSs - the 0170 Personnel Officer, the 1390 Combat Engineer Officer, the 3010 Ground Supply Operations Officer, and the 3510 Motor Transport Maintenance Officer.

In regards to post-secondary education, the 0430 MOS reported only 18.06 percent of the MOS's CWO3-5s as attaining any - compared to 44.2 percent reported by the 0170 MOS, 33.3 percent reported by the 3010 MOS, 23.81 percent reported by the 1390 MOS, and 21.9 percent reported by the 3510 MOS. Not unexpectedly, this trend is repeated in the 0430 LDO ranks.

Table 20 Post Secondary Education Level of Comparable CSS MOSs

CWO3-5	MOS	0430	0170	1390	3010	3510	Total
	n	59	101	16	16	53	1130
HSE	% of MOS	81.90%	55.80%	76.19%	66.67%	79.10%	74.80%
	% of Total	3.90%	6.68%	1.06%	1.06%	3.51%	74.80%
	n	10	33	1	3	9	175
AA	% of MOS	13.90%	18.23%	4.76%	12.50%	13.43%	11.60%
	% of Total	0.70%	2.18%	0.07%	0.20%	0.60%	11.60%
	n	2	30	4	3	3	156
BA	% of MOS	2.80%	16.57%	19.04%	12.50%	4.48%	10.30%
	% of Total	0.10%	1.99%	0.26%	0.20%	0.20%	10.30%
	n	1	17	0	2	2	50
MA	% of MOS	1.40%	9.39%	0.00%	8.33%	2.99%	3.30%
	% of Total	0.10%	1.13%	0.00%	0.13%	0.13%	3.30%

Table 21 reveals little difference in the education level of 0430 LDOs to that reflected in 0430 warrant officer and CWOs.⁴³ Two hundred and seventy-eight LDO majors from 17 unique MOSs were selected in 2005 through 2011, of which 46 were from the 0430 MOS (15.71%). Nearly 70 percent (69.60%) of 0430 LDO majors reported the 12th grade as their

⁴³ The selection data concerning LDO captain education levels was unobtainable for analysis.

highest formal education attained, 13.1 percent higher than the 56.50 percent of the LDO majors from all MOSSs who reported the same.

Table 21 Educational Level of Selected LDO Majors and LtCols

Rank	MOS	HSE		AA		BA		MA		Total	
		n	%	n	%	n	%	n	%	N	%
LDO MAJOR	430	32	69.60%	3	6.50%	10	21.70%	1	2.20%	46	16.50%
	ALL MOSSs	131	56.50%	28	12.10%	58	25.00%	15	6.50%	232	83.50%
	N	163	58.60%	31	11.20%	68	24.50%	16	5.80%	278	100.00%
LDO LTCOL	430	8	53.30%	2	13.30%	3	20.00%	2	13.30%	15	17.40%
	ALL MOSSs	35	49.30%	6	8.50%	25	35.20%	5	7.00%	71	82.60%
	N	43	50.00%	8	9.30%	28	32.60%	7	8.10%	86	100.00%

Table 21 also reports the education levels of LDO LtCols selected in the years 2005 through 2011. There were 86 LDO LtCols selected from 14 MOSSs, with the 0430 MOs having the highest number of selections with 15 (17.40%). Eight 0430 LDO LtCols (53.30%) reported the 12th grade as their highest education - 4.0 percent higher than the 49.30 percent reported by all other MOSSs. Over thirteen percent (13.30%) of 0430 LDO LtCols (2) reported their highest education level as two-years, compared to the 8.50 percent of LDO LtCols (6) from all other MOSSs. Only 20 percent 0430 LDO LtCols (3) reported completing four years of education compared to 35.20% of LDO LtCols (25) from all MOSSs. Two 0430 LDO LtCols (13.30%) reported attaining six-years of education, nearly twice of what was reported by the five LDO LtCols (7.00%) from all other MOSSs. Although, the 0430 LDO LtCol did report having the highest educational level (MA) by percentage, they also reported having the highest percent of both 12th grade education and two-year degrees - the two lowest educational levels.

Experience - Warrant Officer

The third and final component in the MOS Manual's definition that the 0430 Mobility Officer "MOS is technical in nature and requires years of training, education, and experience to become proficient" is **years of experience**. For this analysis, experience is a composite of enlisted feeder MOSs, along with TIS, TIG and age of MOSs performing similar functions. Appendix L displays all warrant officer, chief warrant officer, and LDO major and LtCol TIG, TIS, and age data for selection years 2005 through 2011.⁴⁴

Feeder MOS

By comparing warrant officer selection and promotion data to previous year enlisted promotion data, individual case rank, feeder MOS, and selection year could be identified. Those cases where data was not available were included but are identified as unknown.

In the years 1990 through 2013, 299 warrant officers were selected for the 0430 MOS; whereas, 271 were subsequently promoted to chief warrant officer. The remaining 28 were either too recently selected to warrant officer for consideration to chief warrant officer or had reached their terminal rank. Figure 4 demonstrates the feeder rank and MOSs of the 28 warrant officers not selected to CWO-2 with known feeder MOSs.

⁴⁴ The TIG, TIS and age data was not available for selection years 2012 or 2013.

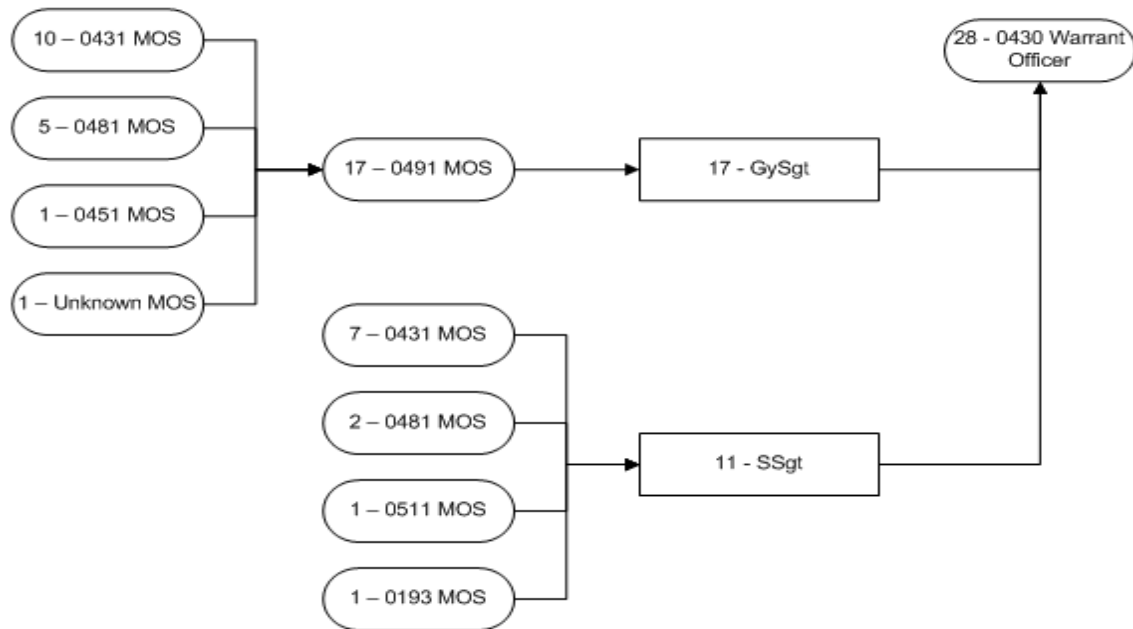

Figure 4 0430 Warrant Officer Feeder Rank and MOS

Specifically, of the 28 0430 warrant officer not selected for CWO-2, 17 were 0491 GySgts (10-0431, 5-0481s, 1-0451 Parachute Rigger, and 1-unknown), and 11 were SSgts (7-0431s, 2-0481s, 1-0193 Personnel/Administration Chief, and 1-0511 MAGTF Planning Specialist MOS).

There were fifty-eight 0430 CWO-2s with known feeder MOSs⁴⁵ selected for promotion between FY93 and FY12 that were either at their terminal rank, or had too little time to be promoted to CWO-3. Of the 27 GySgts with known feeder MOSs, 24 were from the 0491 MOS (18-0431s, 5-0481s, and 1-unknown), two were from the 0511 MOS, and one was from the 2862 Electronics Maintenance Technician MOS. There were thirty-one SSgts with known feeder MOSs, 20-0431s, 4-0481s, 3-0511s, 2-7382 Airborne Radio Operator/In-Flight Fueling Observer/Loadmaster MOS, 1-

⁴⁵ Two 0430 CWO-2 feeder MOSs could not be identified.

3043 MOS, and 1-3537 Motor Transport Operator MOS. Figure 5 displays the 0430 CWO-2 MOS feeder ranks and MOSs.

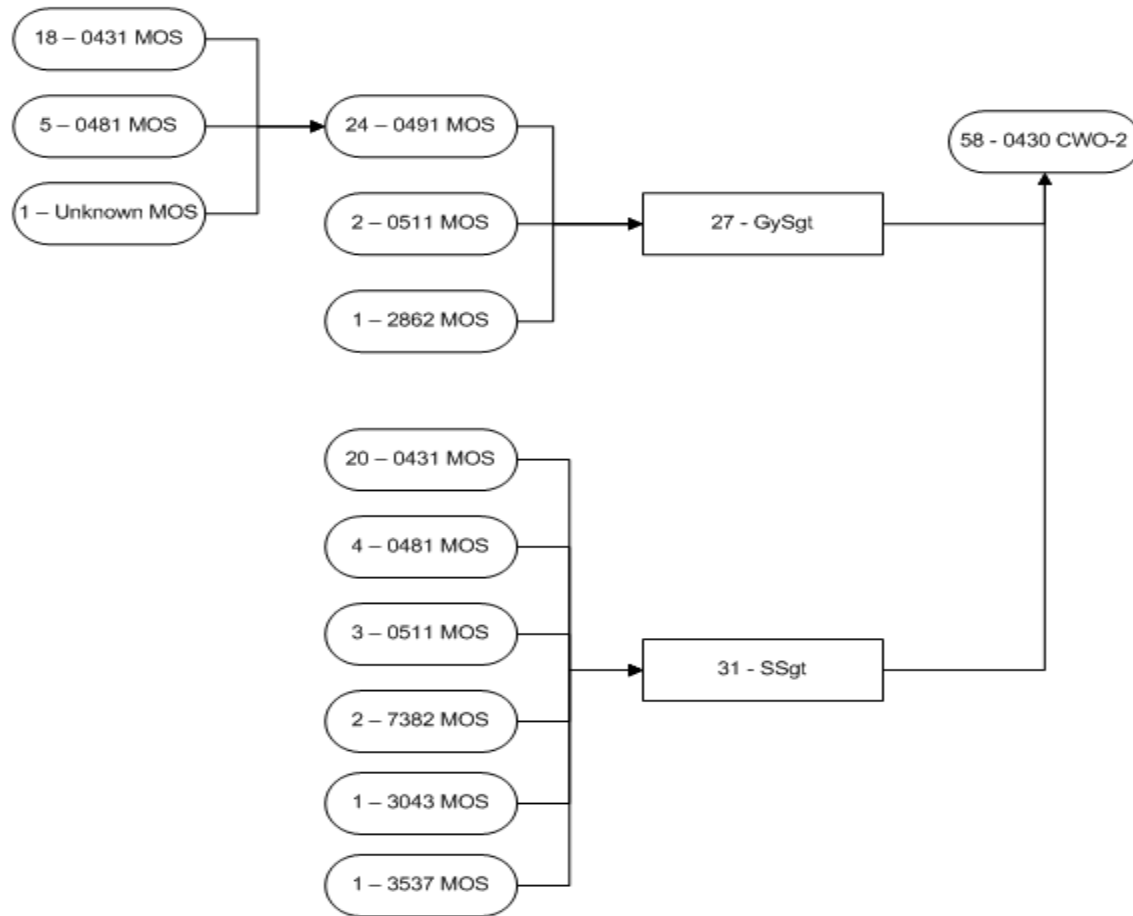

Figure 5 0430 CWO-2 Feeder Rank and MOS

There were thirty-two yet to be promoted (or terminal) CWO-3s in the 0430 MOS with known feeder MOSs selected between FY94 and FY12.⁴⁶ Of the 32 0430 CWO-3s selected with known feeder MOSs, 18 were GySgts; 16-0491 MOS (8-0431s, 7-0481s, and 1-0411), 1-0369 Infantry Unit Leader MOS, and 1-unknown MOS. Of the remaining 0430 CWO-3s, there were 13 SSgts (9-0431s, 1-0481, 1-0511, 1-1142 Electrical Equipment

⁴⁶ The feeder MOSs for six 0430 CWO-3s could not be determined.

Repair Specialist MOS, and 1-3537) and one 0431 Sgt. Figure 6 identifies the feeder ranks and MOSs of CWO-3s in the 0430 MOS.

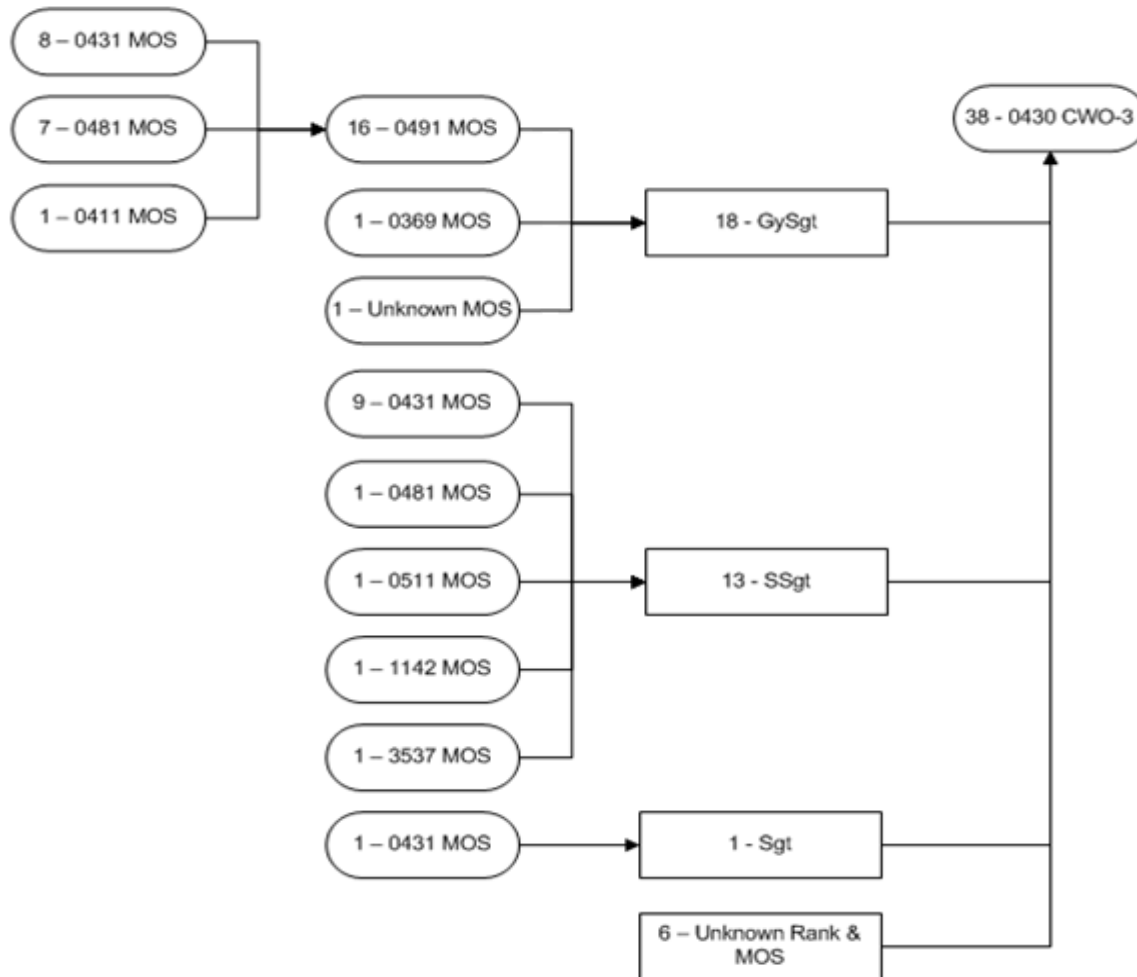

Figure 6 0430 CWO-3 Feeder Rank and MOS

There were twenty-one 0430 CWO-4s with known feeder MOSs selected for promotion between FY98 and FY12.⁴⁷ Of the twenty-one known feeder ranks, ten were GySgts from the 0491 MOS (7-0431s and 3-0481s), nine were SSgts (8-0431s and 1-0481), and two were sergeants from the 0431 MOS. Figure 7 reports the feeder ranks and MOSs.

⁴⁷ The feeder MOSs for eight 0430 CWO-4s could not be determined.

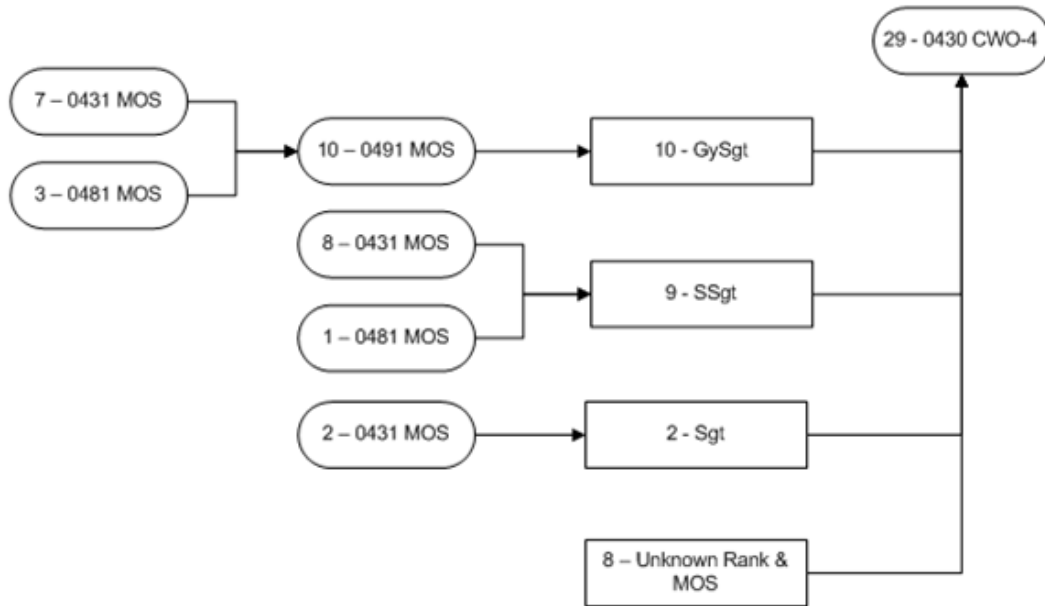

Figure 7 0430 MOS CWO-4 Feeder Rank and MOS

There were four CWO-5s with known feeder MOSs⁴⁸ selected for promotion in the 0430 MOS between FY00 and FY10 (Figure 8). Of the 0430 CWO-5s with known feeder MOSs, one was a 0491 GySgt (1-0431) and three were SSgts (3-0431s).

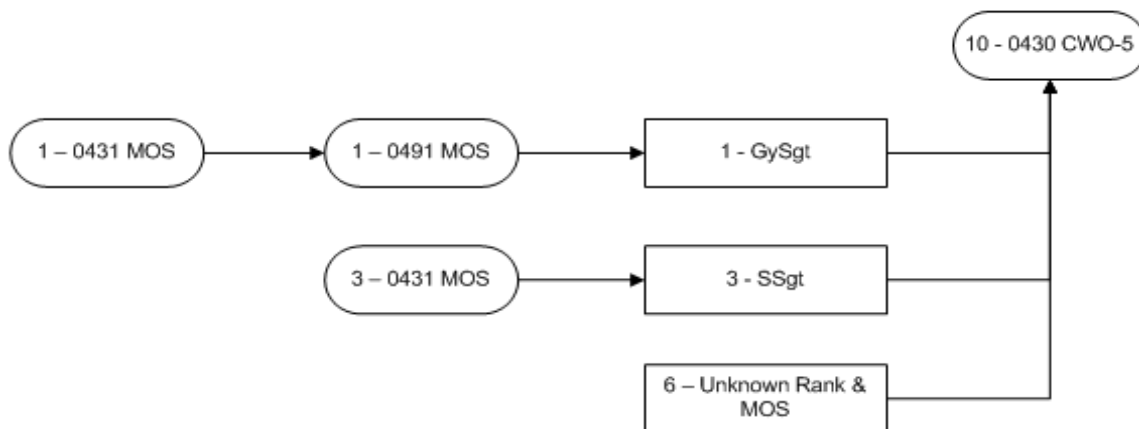

Figure 8 0430 CWO-5 Feeder Ranks and MOSs

⁴⁸ The feeder MOSs for six 0430 CWO-5s could not be determined.

There were forty-one 0430 LDO captains selected for promotion from the warrant officer ranks between FY97 and FY13 with known feeder MOSs.⁴⁹ Initially, 19 GySgts, 20 SSgts, and 2 Sgts were selected for warrant officer and subsequently promoted to 0430 MOS LDO captain. From the GySgts, there were from the 17 0491s (11-0431s and 6-0481s), one 0511 MOS, and one from an unknown MOS. There were 20 SSgts (16-0431s, 3-0481s, and one 3537) and two sergeants (2-0431s). Figure 9 identifies the feeder rank and MOS initially held prior to selection to warrant officer and chief warrant officer.

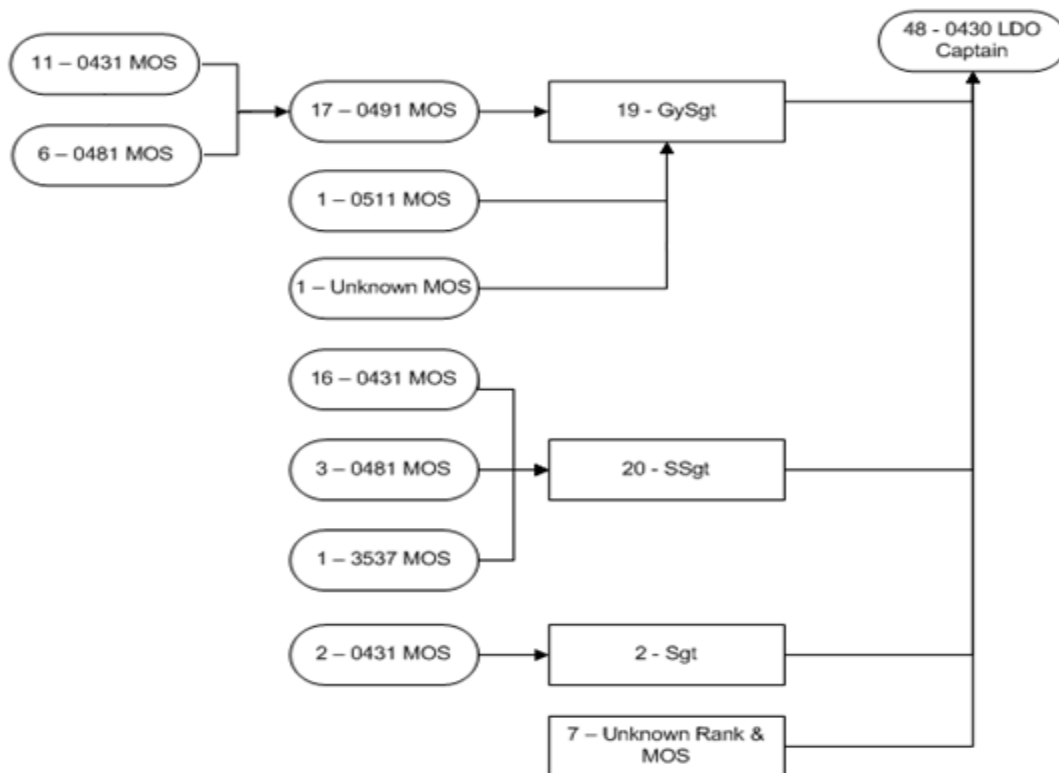

Figure 9 0430 LDO Captain Feeder Ranks & MOSs

From FY98 to FY12, sixty-two LDO majors were selected for promotion in the 0430 MOS; whereas, thirty-three could be linked to

⁴⁹ The feeder MOSs for seven 0430 LDO captains could not be determined.

known feeder MOSs.⁵⁰ Of the 0430 LDO majors with known feeder MOSs, there were eight GySgts from the 0491 MOS (7-0431s and 1-0481), twenty-one SSgts (20-0431s and 1-0481) and four sergeants from the 0431 MOS. Figure 10 displays the feeder ranks and MOSs for 0430 LDO majors.

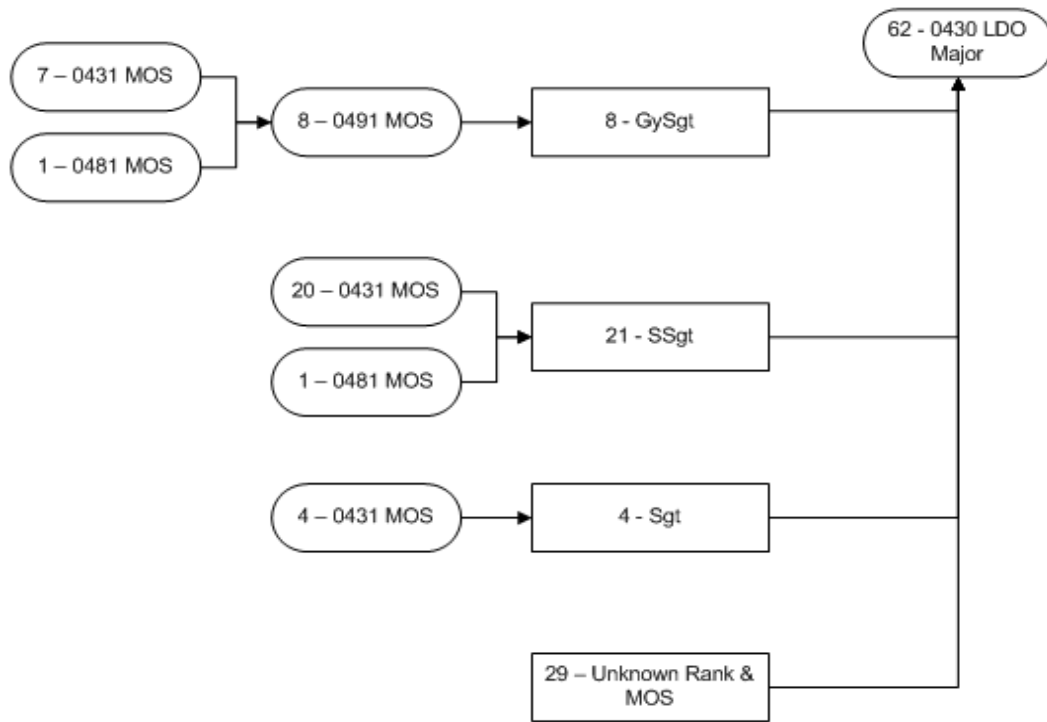

Figure 10 0430 LDO Major Feeder Ranks & MOSs

From FY99 to FY12, there were twenty-one 0430 LDO LtCols selected for promotion. Of the selected, only six could be traced back to known feeder MOSs.⁵¹ Of the six known feeder MOSs, five were SSgts (3-0431s, 1-0481, and 1-2537 Radio Chief), and one a 0481 sergeant. Figure 11 displays the feeder MOSs and ranks.

⁵⁰ The feeder MOSs for 29 0430 LDO majors could not be determined.

⁵¹ The feeder MOSs for 15 0430 LDO LtCols could not be determined.

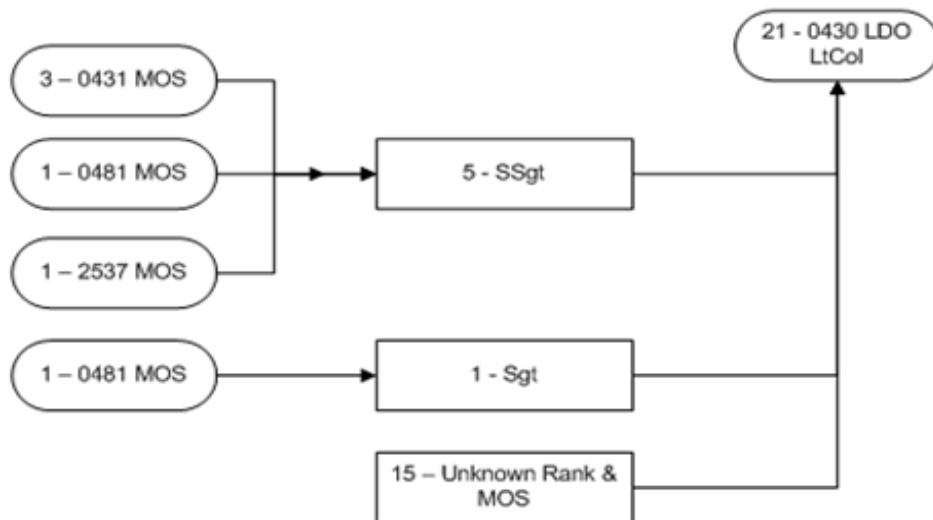

Figure 11 0430 LDO LtCol Feeder Ranks and MOSs

Time in Grade (TIG) and Time in Service (TIS)

The 2010 warrant officer selection data is displayed in Table 22. Of the 602 eligible candidates in all MOSs, 243 were selected to warrant officers (40.36%).

Table 22 2010 Warrant Officer Selection Results

2010 Warrant Officer Selection Results	n = Eligible for Selection	n = Selected (All MOSs)	n = Selected (0430 MOS)
Gunnery Sergeant	179	115	10
Staff Sergeant	395	124	12
Sergeant	28	4	0
Total	602	243	22

There were 115 GySgts (47.33%), 124 SSgts (51.02%), and 4 Sgts (1.6%) selected from 42 unique MOSs to fill the 243 warrant officer allocations with an average TIS of 11 years, 5 months. There were 28 candidates considered for the 22 0430 warrant officers selected, equaling a 78.57 percent selection rate - nearly twice that of the eligible candidates for all other MOSs. There were 10 GySgts and 12 SSgts selected for 0430 warrant officer in 2010. It was possible to

determine the average TIS of the 0430 warrant officers selected in 2010 by examining the date active service began of individual case feeder ranks and MOSs. Table 23 reports the TIS for the 22 0430 MOS selections in 2010 ranged from 8 years, 4 months to 15 years, 3 months, with an average of 11 years, 5 months - matching the norm for all warrant officers selected in 2010.

Table 23 TIS of Warrant Officer Feeder Ranks Selected in 2010

Feeder Rank	N	Range		Average TIS
		Low TIS	High TIS	
GySgt & SSgt	22	8 yrs, 4 mos	15 yrs, 3 mos	11 yrs, 5 mos
GySgts	10	11 yrs, 5 mos	14 yrs, 6 mos	12 yrs, 7 mos
SSgts	12	8 yrs, 4 mos	15 yrs, 3 mos	10 yrs, 5 mos

The TIS of the GySgts (both 0491s and 0511) ranged from 11 years, 5 months to 14 years, 6 months with average TIS of 12 years, 7 months; while the TIS of the 12 SSgts (0431s, 0481s, and 0511) ranged from 8 years, 4 months to 15 years, 3 months with average TIS of 10 years, 5 months.

As the TIS was higher than average for the GySgts but lower than average for the SSgts, an analysis of the TIG of 0430 MOS feeder MOSs was warranted. Table 24 provides a breakdown of the TIG by rank and feeder MOS of the twenty-two 0430 warrant officers selected in 2010.

Table 24 TIG of Warrant Officer Feeder Ranks Selected in 2010

Feeder Rank	N	Range		Average TIG
		Low TIG	High TIG	
GySgt & SSgt	22	3 mos	6 yrs, 11 mos	1 yr, 9 mos
GySgts	10	3 mos	2 yrs, 11 mos	1 yr, 4 mos
SSgts	12	6 mos	6 yrs, 11 mos	2 yrs, 4 mos

Feeder Rank & MOS	N	Range		Average TIG
		Low TIG	High TIG	
GySgt 0491	9	10 mos	2 yrs, 11 mos	1 yr, 5 mos
GySgt 0511	1	3 mos		3 mos
SSgt 0431	9	6 mos	6 yrs, 11 mos	2 yr, 4 mos
SSgt 0481	2	1 yr, 8 mos	2 yrs, 10 mos	2 yr, 3 mos
SSgt 0511	1	2 yrs, 3 mos		2 yr, 3 mos

The average TIG for both GySgts and SSgts (0431, 0481, 0491, and 0511) ranged from three months to 6 years, 11 months with an average TIG of 1 year, 9 months. Time in grade for the ten GySgts (both 0491s and 0511) ranged from 3 months to 2 years, 11 months with an average TIG of 1 year, 4 months. The 12 SSgts (0431s, 0481s, and 0511) had an average TIG that ranged from 6 months to 6 years, 11 months with average TIS of 2 years, 4 months.

Chief Warrant Officer-2

No CWO-2 TIS, TIG, or age data was available for analysis.

Chief Warrant Officer-3

Table 25 reports the TIG, TIS, and age of the 769 CWO-3s selected for promotion from 48 unique MOSs in 2006 through 2009. CWO-3s from all other MOSs were selected with an average TIG of 2.85 years, average TIS of 17.01 years, and an average age of 36.92 years. The 41 0430 CWO-3s selected had an average TIG of 2.93 years, average TIS of 15.33 years, and an average age of 35.07 years.

Table 25 Average TIG, TIS and Age of CWO-3 Selections

CWO3	MOS	N	M	SD	Std. Error Mean
TIG	0430	41	2.928	0.5572	0.0870
	ALL	728	2.851	0.6990	0.0259
TIS	0430	41	15.332	1.0070	0.1573
	ALL	728	17.010	1.5355	0.0569
AGE	0430	41	35.068	1.3078	0.2042
	ALL	728	36.915	1.7525	0.0650

Because the mean averages of the 0430 were not dependent on the mean averages of all other MOSs, an independent sample t-test was conducted to produce the probabilities necessary to determine if there were any differences between the TIG, TIS, and age of 0430 CWO-3s and all other MOSs, and if the differences were statistical significance. The results of the t test shown in Table 26 indicate that although the 0430 CWO-3s had a higher average TIG than CWO-3s selected from all other MOSs, but that the differences were not statistically significant (0430 MOS, M = 2.92, SD = .557; all MOSs M = 2.85, SD = .698) conditions; $t(47.38) = .843, p = .403$).

Table 26 Results of the Independent t test for 0430 CWO-3s

CWO3	F	Sig.	t	df	Sig. (2-tailed)	Mean Dif.	Std. Error Dif.	95% Confidence Interval of the Difference	
								Lower	Upper
TIG	5.559	0.019	0.843	47.38	0.403	0.077	0.091	-0.106	0.259
TIS	5.331	0.021	-10.572	51.12	0.000	-1.768	0.167	-2.104	-1.432
AGE	0.38	0.538	-6.643	767	0.000	-1.847	0.278	-2.393	-1.301

In regards to TIS, the 0430 MOS had a significantly lower TIS (M = 15.33, SD = 1.01) compared to all other MOSs (M = 17.01, SD = 1.54) conditions; $t(51.115) = -10.572, p = .000$). The 0430 MOS was also significantly younger when selected for promotion than all other MOS

(0430 M = 35.07, SD = 1.308; all MOSs M = 36.92, SD = 1.76)

conditions; $t(767) = -6.643, p = .000$).

Chief Warrant Officer-4

The TIG, TIS, and age of the 334 CWO-4s from all MOSs selected for promotion in the years 2006 through 2009 is shown in Table 27. The 322 CWO-4s selected from all MOSs had an average TIG of 2.84 years, average TIS of 20.41 years, and an average age of 40.22 years. The twelve 0430 CWO-4s selected had an average TIG of 2.52 years, average TIS of 19.34 years, and an average age of 39.30 years.

Table 27 Average TIG, TIS and Age of CWO-3 Selections

CWO4	MOS	N	M	SD	Std. Error Mean
TIG	0430	12	2.523	0.3625	0.1046
	ALL	322	2.838	0.6311	0.0352
TIS	0430	12	19.343	2.2685	0.6549
	ALL	322	20.409	1.5557	0.0867
AGE	0430	12	39.300	1.6874	0.4871
	ALL	322	40.218	2.0183	0.1125

Although 0430 CWO-4s were selected with fewer years of experience (both in grade and in service) and were younger than their peers from all other MOSs, the results of the t test (Table 28) show the differences were not statistically significant.

Table 28 Results of Independent t test for 0430 CWO-4s

CWO4	F	Sig.	t	df	Sig. (2-tailed)	Mean Dif.	Std. Error Dif.	95% Confidence Interval of the Difference	
								Lower	Upper
TIG	1.242	0.266	-1.715	332	0.087	-0.315	0.184	-0.680	0.046
TIS	11.204	0.001	-1.614	11.39	0.134	-1.066	0.661	-2.514	0.382
AGE	0.077	0.782	-1.555	332	0.121	-0.918	0.590	-2.079	0.244

Chief Warrant Officer 5

Table 29 reports the TIG, TIS, and age of the 105 CWO-5s selected 2006 through 2009. The 101 CWO-5s from all MOSs had an average TIG of 2.69 years, average TIS of 23.34 years, and an average age of 43.30 years. The four 0430 CWO-5s selected had an average TIG of 2.25 years, average TIS of 22.13 years, and an average age of 42.25 years.

Table 29 Average TIG, TIS and Age of CWO-5 Selections (2006-09)

CWO5	MOS	N	M	SD	Std. Error Mean
TIG	0430	4	2.250	0.5000	.25000
	ALL	101	2.686	0.8737	.08693
TIS	0430	4	22.125	1.0500	.52500
	ALL	101	23.344	2.0307	.20206
AGE	0430	4	42.250	1.9000	.95000
	ALL	101	43.300	2.6570	.26438

The results of the t test presented in Table 30 indicate that even though the 0430 CWO-5s had a lower TIG average, a lower TIS average, and were younger than CWO-5s selected from all other MOSs, the differences were not statistically significant.

Table 30 Results of the Independent t test for 0430 CWO-5s

CWO5	F	Sig.	t	df	Sig. (2-tailed)	Mean Dif.	Std. Error Dif.	95% Confidence Interval of the Difference	
								Lower	Upper
TIG	0.763	0.384	-0.988	103	0.326	-0.436	0.441	-1.310	0.439
TIS	2.475	0.119	-1.19	103	0.237	-1.219	1.024	-3.250	0.812
AGE	0.308	0.58	-0.781	103	0.437	-1.050	1.345	-3.717	1.617

Chief Warrant Officer 3-5 Combined

There were 1208 CWO3-5s selected for promotion in the years 2006 through 2009, as shown in Table 31. The 1151 CWO3-5s selected from MOSs other than the 0430 MOS had an average TIG of 2.83 years, average

TIS of 18.57 years, and an average age of 38.39 years. There were 57 0430 CWO3-5s selected (4.7%) with an average TIG of 2.79 years, average TIS of 16.65 years, and an average age of 36.46 years.

Table 31 Average TIG, TIS and Age of CWO3-5 Selections (2006-09)

CWO3-5	MOS	N	M	SD	Std. Error Mean
TIG	0430	57	2.7953	0.5577	.07386
	ALL	1151	2.8332	0.6989	.02060
TIS	0430	57	16.653	2.6004	.34443
	ALL	1151	18.574	2.6157	.07710
AGE	0430	57	36.463	2.7414	.36311
	ALL	1151	38.399	2.8499	.08400

The findings indicate that when 0430 CWO-3s, CWO-4s and CWO-5s are combined their average TIG, TIS, and age when selected for promotion remain lower than what was required for all other MOSs with combined CWO3-5s. Although, the 0430 MOS required less time and were younger than other MOSs selected during the same time, the results of the t test (presented in Table 32) demonstrate that differences were only statistically significant for TIS and age - and not for TIG.

Table 32 Results of Independent t test for 0430 CWO3-5 Selections

CWO3-5	F	Sig.	t	df	Sig. (2-tailed)	Mean Dif.	Std. Error Dif.	95% Confidence Interval of the Difference	
								Lower	Upper
TIG	1.888	.170	-.403	1206	0.687	-0.038	0.094	-0.222	0.147
TIS	.826	.364	-5.413	1206	0.000	-1.921	0.355	-2.617	-1.225
AGE	.801	.371	-5.016	1206	0.000	-1.936	0.386	-2.694	-1.179

Specifically, the TIG significance of .687 is greater than .10; therefore, the difference was not statistically significant. Whereas, a significance level of .000 suggests that the TIS of 0430 CWO3-5s (16.65 years) is significantly less than the TIS of all CWO3-5s (18.57

years). The identical significance level of .000 indicates that the age 0430 CWO3-5s were selected (36.46 years) was significantly lower than the age required of CWO3-5s in all other MOSs (38.39 years). Overall, the findings indicate that the 0430 MOS selects its CWO3-5s with on average less TIS and at a younger age than their peers in all other MOSs.

Warrant Officer and LDO Selection Rate

Appendix M displays the available data collected for the 2010 warrant officer, the data for CWO3-5s collected in 2005 through 2012, and the LDO major and LtCol selection data for 2005 through 2013. No data was available for CWO-2s.

In 2010, there were 602 applicants considered for warrant officer in 42 unique fields, of which 243 were selected (40.37%). With 22 selections out of 28 applicants (78.57%), the 0430 MOS had the second highest number of warrant officers selected (only behind the 0210 MOS) accounting for nearly ten percent (9.05%) of all warrant officers selected in 2010.

For all MOSs, there were 2,362 quotas for CWO-3 in 2005 through 2012, of which 1,562 CWO-3s were selected (66.13%) from 48 unique MOSs. There were 121 0430 CWO-2s considered and ninety-one selected (75.21%) for promotion, nearly 10 percent higher (9.08%) than the average selection rate of all MOSs. The 0430 CWO-3 had the second highest number of selections (only behind the 0170 MOS) with 172; although, the 0430 CWO-3's selection rate was 5.57 percent higher than the 0170 CWO-3 selection rate of 69.64 percent.

Between 2005 through 2012, there were 1,234 CWO-3s considered and 680 CWO-4s selected (55.11%) from 52 unique MOSs. There were 49 0430s considered, and 28 selected (57.14%), 2.08 percent higher than the average 0430 CWO-4 selected and the sixth most selected MOS.

Between 2005 and 2012, there were 501 CWO-4s considered and 207 CWO-5s selected (41.32%) from 46 unique MOSs. Sixteen 0430 CWO-4s were considered and five were selected for CWO-5 (31.25%).

When all chief warrant officer selection data was combined, there were 4,097 CWO2-4s considered and 2,449 CWO3-5s selected (59.78%) for promotion to the next highest rank from 52 unique MOSs. There were 186 0430 CWO2-4s considered and 124 CWO3-5s selected (66.67%) - equaling a 6.89 percent higher selection rate than average.

Between 2005 through 2013, there were 682 LDO captains considered for the 350 LDO majors selected (51.32%) from 16 unique MOSs. Fifty-seven 0430 LDO majors were selected from the 101 0430 LDO captains considered (56.44%) - 5.12 percent higher than the average of all other MOSs. The 0430 LDO major selections also accounted for 16.29 percent of all LDO majors selected - more than any other MOS. The second most selected MOS was the 6302 MOS with 39 selections (18 LDO majors less than the 0430 MOS) and accounting for only 11.14 percent of all LDO majors selected.

In the years 2005 through 2011, there were 110 LtCols selected (36.54%) from the 301 LDO majors considered for promotion. Seventeen 0430 LDO LtCols were selected from the 49 0430 LDO majors considered (34.69%) - 1.85 percent fewer than their peers. Nevertheless, the 0430 LDO LtCol still accounted for the most (with 17) and the highest

percent (15.45%) of LDO LtCols selected. The 2102 Ordnance Officer and 6004 Aircraft Maintenance Engineer Officer MOSs had the second most selections (with 12) accounting for 10.91 percent (each) of all LtCols selected.

The MOSs that select warrant officers and LDOs were examined to determine the highest proportion of selectees against total MOS manpower strength. Table 33⁵² displays the MOS's personnel strength of restricted officer and enlisted ranks. Columns are rank ordered by the size of the population and an additional column reports the percentage of restricted officers to MOS strength.

It could reasonably be expected that the 0306 Infantry Weapons Officer MOS (from the largest MOS), the 0610 Telecommunication Systems Engineering Officer MOS (the 2nd largest MOS) or even the 3510 Motor Transport Maintenance Officer MOS (the 3rd largest MOS) would have the most warrant officer and LDO selections, but the findings do not support that belief.

⁵² Retrieved from: <https://www.manpower.usmc.mil/cp/cp/frame.jsp>.

Table 33 Total U.S. Marine Corps Manpower Strength

MOS	N	WO & LDO			Enlisted	
		MOS	n	% of N	MOS	n
03XX	60607	01XX	316	2.52%	03XX	56862
06XX	25119	04XX	186	1.97%	35XX	24502
35XX	24628	60XX	155	2.03%	06XX	23269
13XX	16681	06XX	152	0.61%	13XX	15548
01XX	12542	13XX	131	0.79%	30XX	11313
30XX	12328	35XX	126	0.51%	01XX	11246
04XX	9454	21XX	119	1.68%	61XX	8996
08XX	9346	03XX	104	0.17%	08XX	7855
61XX	8996	28XX	70	0.97%	28XX	7067
60XX	7649	30XX	44	0.36%	58XX	6971
58XX	7394	08XX	40	0.43%	60XX	6944
28XX	7184	58XX	39	0.53%	21XX	6928
21XX	7082	61XX	0	0.00%	04XX	6798

Rather, the 01XX Personnel and Administration MOS reported the highest number of warrant officers (the 01XX MOS does not promote LDOs) followed by the 0430 Mobility Officer MOS with the second highest number of warrant officers and LDOs even though it is the seventh largest MOS overall.

LDO Captain

Data concerning selection rate, TIG, TIS, age, and education statistics for LDO captains were not available for analysis; although, by determining each case's enlisted promotion date to the subsequent date each case was selected to LDO captain, individual TIG could be computed and an average TIG could be determined. As such, it took the 19 GySgts an average of 7.84 years to be selected to LDO captain, while the 20 SSgts took an average of 8.5 years. The two sergeants took an average of 12 years.

LDO Major

There were 278 LDO majors selected in the years 2006 through 2011, of which forty-six were 0430 LDO majors (16.55%). The average TIG, TIS and age of all LDO majors selected is reported in Table 34.

Table 34 Average TIG, TIS and Age of LDO Major Selections

LDO MAJ	MOS	N	M	SD	Std. Error Mean
TIG	430	46	3.326	0.3991	0.0589
	ALL	232	3.520	0.9015	0.0592
TIS	430	46	19.840	0.7874	0.1161
	ALL	232	22.305	2.0786	0.1365
AGE	430	46	39.896	1.6254	0.2397
	ALL	232	41.064	6.4090	0.4208

The 0430 LDO majors were selected with an average TIG of 3.33 years, average TIS of 19.84 years, and an average age of 39.89 years, which was considerably lower than the average TIG of 3.52 years, average TIS of 22.30 years, and an average age of 41.06 years required of the other 232 LDO majors selected from all other MOSs.

Table 35 Results of the Independent t test for 0430 LDO Majors

LDO MAJ	F	Sig.	t	df	Sig. (2-tailed)	Mean Dif.	Std. Error Dif.	95% Confidence Interval of the Difference	
								Lower	Upper
TIG	9.783	0.002	-2.324	151.82	0.021	-0.194	0.084	-0.359	-0.029
TIS	7.647	0.006	-13.756	186.08	0.000	-2.465	0.179	-2.818	-2.111
AGE	1.796	0.181	-1.227	276	0.221	-1.168	0.952	-3.043	0.707

The results of the t test presented in Table 35 indicate that 0430 LDO majors required less TIG (less time as a captain) on average than LDO majors selected from all other MOSs and that the differences were statistically significant (0430 MOS, M = 3.33, SD = .399; all MOSs M = 3.52, SD = .901) conditions; $t(151.82) = -2.324, p = .021$].

In regards to TIS, the 0430 LDO major required significantly fewer years in service (M = 19.84, SD = .787) compared to all other MOSs (M = 22.30, SD = 2.08) conditions; $t(186.08) = -13.756, p = .000$). Although the age for 0430 LDO major selection was one year and two months less than all other MOS, it was not statistically significant.

LDO Lieutenant Colonel (LtCol)

There were 86 LDO LtCols selected from all MOSs in the years 2005 through 2011, of which 15 were from the 0430 MOS (17.44%). The 71 LDO LtCols selected from all MOSs had an average TIG of 4.09 years, average TIS of 27.11 years, and an average age of 46.22 years. Whereas, the 0430 LDO LtCols selected had an average TIG of 4.57 years, average TIS of 25.74 years, and an average age of 45.53 years.

Table 36 Average TIG, TIS and Age of LDO LtCol Selections

LDO LTCOL	MOS	N	M	SD	Std. Error Mean
TIG	430	15	4.573	1.0724	0.2769
	ALL	71	4.099	0.9668	0.1147
TIS	430	15	25.740	1.3827	0.3570
	ALL	71	27.114	5.1284	0.6086
AGE	430	15	45.527	1.5805	0.4081
	ALL	71	46.223	2.2457	0.2665

Table 36 demonstrates that while 0430 LDO LtCols required more TIG (.52 years) than their peers did, they conversely required less TIS (1.6 years) and were therefore younger (1.3 years) than all other LDO LtCols selected for promotion. Even though there was a difference between the average number of years it took for an 0430 LDO LtCol to

be selected, the results of the t test presented in Table 37 indicate that the differences were not statistically significant.

Table 37 Results of the Independent t test for 0430 LDO LtCols

LDO LTCOL	F	Sig.	t	df	Sig. (2- tailed)	Mean Dif.	Std. Error Dif.	95% Confidence Interval of the Difference	
								Lower	Upper
TIG	1.144	0.288	1.693	84	0.094	0.474	0.278	-0.083	1.031
TIS	0.522	0.472	-1.025	84	0.308	-1.374	1.340	-4.039	1.291
AGE	1.439	0.234	-1.139	84	0.258	-0.696	0.611	-1.910	0.517

0402 Logistics Officer MOS

The 0402 Logistics Officer MOS was the last 04XX MOS critically analyzed. As an unrestricted officer, the 0402 logistics officer is not designated as an LDO, but begins their career as a second lieutenant. Second lieutenants are promoted based on TIG requirements found in section 619 of Title 10, U.S. Code and as determined by the Secretary of the Navy under SECNAVINST 1412.6L. Unrestricted officers must compete via selection boards against peers of the same grade in all other MOSs for promotion to captain through major general. A critical review of guiding references, formal training, billet assignments, and selection rate reveals that the 0402 MOS lacks foundational substance and subject matter expertise - especially when compared to their unrestricted officer peers.

MOS Manual

The occupational field sponsor - with feedback from the operating forces and formal schools - drafts the MOS Manual to describe the duties, functions, and associated requirements of specific MOSs. In regards to the 0402 MOS, the MOS Manual directs that "Logistics

Officers plan, coordinate, execute and/or supervise the execution of all logistics functions and the six functional areas of tactical logistics: supply, maintenance, transportation, general engineering, health services, and services. Logistics officers serve as commanders or assistants to the commanders of tactical logistics units/elements and as members of general or executive staffs in the operating forces, supporting establishment, and joint staffs. They perform duties of mobility officer, maintenance management officer, motor transport officer, landing support officers, and are responsible for administrative and tactical unit movement of personnel, supplies, and equipment by all modes of transportation" (pg. 1-20).⁵³

The stark brevity of the MOS Manual's description of the 0402 MOS was immediately apparent when compared to other officer MOSs. The MOS Manual uses only 14 lines (161 words) to encompass the duties, billets, prerequisites, and requirements of the 0402 MOS (Appendix N), considerably less than the 41 lines (465 words) used to summarize the 1302 Combat Engineer Officer MOS or the 50 lines (560 words) used to summarize the 0430 Mobility Officer MOS. While an MOS description does not have to be elaborate or loquacious, it seems logical and appropriate that a MOS with such expansive and widely diverse duties and responsibilities as the 0402 MOS would be more descriptive and informative.

Due in part to the MOS Manual's brief description of the 0402 MOS, the MOS Handbook was also examined for supplemental information regarding MOS-specific duties and assignments. The MOS Handbook is

⁵³ (see Footnote 2).

crafted by officer assignment experts to give U.S. Marine Corps second lieutenants (2ndLt) an "overview of officer's MOSs to assist them in deciding their preferences for MOS selection at The Basic School (TBS)".⁵⁴ The MOS Handbook reiterates the diversity of duties inherent to the 0402 MOS: "As a logistician, you may find yourself leading as few as three Marines or as many as a hundred Marines. The wide spectrum of duties and responsibilities as both staff officer and platoon commander offers a number of leadership challenges" (pg. 22).

The MOS Handbook amplifies that an individual in the 0402 MOS could be assigned to any of many billets related to tactical logistics. Specifically, a 0402 can serve as an Operations Officer, a battalion/support squadron Assistant Logistics Officer (S-4A), a Maintenance Management Officer (MMO), a Division or Wing Motor Transport Officer (MTO), or serve as a platoon commander in either the MEU Service Support Group (MSSG), Transportation Support Battalion (TSB), Landing Support Platoon, Motor Transport Platoon, Motor Transport Platoon (focused on equipment readiness (MMO), or even in an Air Delivery Platoon. With the wide latitude of billets, and implied high level of responsibility inherent, it would be expected that an individual assigned to the 0402 MOS would be extensively trained to successfully perform in any of these assignments. Taking into account the criticality of the billets and the associated cautious performance expectations anticipated of the 0402 logistics officer, it seems minimalistic that only a single formal training course is required or recommended for an individual's entire career as an 0402 MOS. This

⁵⁴ Retrieved from the USMC Officer Programs Website: <https://marines.usmc.mil>.

means that the only *mandatory* MOS-specific formal training necessary for an 0402 logistics officer to successfully complete - from 2ndLt through LtCol - is the single, 56-day, entry-level Logistics Officer Course (LOC).⁵⁵

Formal Learning

In light of the MOS Manual and MOS Handbook's prodigious billet expectations of the 0402 logistics officer, a single formal course seems inadequate - especially when compared to other military occupational specialties with more foundational MOS-specific training. Most organizational leaders would agree that a firm underpinning of foundational processes is critical for establishing expertise as much as a proper stance is required in baseball or boxing. Any building contractor would also stress that a sturdy foundation is essential for stability and growth. In the majority of military occupations, individuals are trained to master specific learning objectives in order to competently perform specific duties and essential tasks. These initial learning objectives serve as the foundation for all continued learning and subsequent expertise. Once an individual's performance reaches a certain proficiency level and they display the requisite maturity, collateral duties (supply, maintenance management, HAZMAT, embarkation, tool assignment, test equipment, etc.) are introduced via MOJT or in many cases at the local organizational level.

Over time, and concurrent with increased levels of responsibility, the individual gains expertise, confidence, and

⁵⁵ Logistics Officers Course (LOC) CID M03LAV7 dated 7 October 2012.

proficiency in all facets of their MOS by building on their occupational specialty's stable foundation. This creates a clear line from the novice entry-level learner to the competent performer who executes expertly in both the enlisted and officer ranks (less a few exceptions noted herein).

Accordingly, success is attained by creating unambiguous MOS-specific skill sets where formal training is critical, learning objectives are cogently mastered, and performance is meticulously documented. In this way, foundations become *foundational* for scaffolding learning - especially in unfamiliar or novel areas. By simply comparing the 0402 Logistics Officer MOS training requirements to those of the 0802 Field Artillery Officer MOS reveals a lack of well-defined foundational objectives in the 0402 MOS.

The 0802 field artillery officer begins their career by successfully completing the 190-day Field Artillery Basic Officer Leader Course and the 28-day Field Artillery Officer Course.⁵⁶ With over seven months of exclusive field artillery training, these two courses build on previous knowledge to create a solid foundation of progressively more complex concepts and functions. With ordered expertise, this MOS-specific foundational material becomes so ingrained that it serves as a focal point of reference for any future endeavor. Therefore, when the 0802 field artillery officer is later assigned to a staff billet outside of their area of expertise - most likely to oversee unfamiliar sections, personnel and/or systems - they can apply the foundational knowledge of familiar and specific

⁵⁶ FY2012-2016 Training Input Plan (TIP) MOS Training Tracks (pg. TT-19).

processes gained through experience and known to produce successful results. A better perspective can be gained by examining two of the six tactical functions of logistics that the 0402 logistics officer is responsible for overseeing, specifically engineering and supply.

The 13XX engineering occupational field has roughly 16,681 Marines while the 30XX supply field has approximately 12,328, making them the fourth and sixth largest MOSs, respectively. Both are larger than logistics, which is the seventh largest with 9,454 officer and enlisted Marines.⁵⁷

As the fourth largest occupational field, the 1302 engineer officer must successfully complete an 81-training day, engineering-specific formal course to master the basic and supervisory level operational planning skills pertaining to administration, mobility, counter-mobility, survivability, demolitions, reconnaissance, maintenance, and general engineering.⁵⁸ Whereas, as the sixth largest occupational field, the 3002 ground supply officer must successfully complete the 58-training day, formal course built exclusively with ground supply and operations-specific course material. The course curriculum includes supply support for the Logistics Combat Element (LCE), material distribution, operational planning teams, logistical decision making, embarkation, investigations, consolidated memorandum report (CMR), Missing, Lost, Stolen, and Recovered (MLSR) report, inventory procedures, allowance management, property management, requisitioning procedures, maintenance management, budget formulation

⁵⁷ (see Footnote 46)

⁵⁸ Combat Engineer Officer Course (M03ACC2) dated 5 February 2013.

and execution, contracting, fiscal management, personal effects, audit and verification procedures, certificates of relief, and unit training management.⁵⁹

On the other hand, as the seventh largest occupational field the 0402 logistics officer attends an abbreviated 56-day course comprised of an assortment of eclectic training topics. The LOC course includes lesson material pertaining to engineer support, motor transport, materials handling, logistics planning, determining requirements, maintenance management and maintenance programs, tables of organization and equipment, armory operations, facilities, embark, landing support, air delivery, health services, aviation support, unit training management, and supporting the battalion landing team in the attack.

The 1302 and 3002 MOSs requires 81- and 58-training days respectively to build MOS-specific expertise within novice learners to the level where they are capable of leading their MOS. As such, it seems incongruous that the 0402 MOS is able to condense not only engineering and supply, but also motor transport maintenance and operations, embarkation, landing support, distributive operations, armory, facilities, etc., into a shorter 56-training day course. Instead of the LOC creating an expert in a particular occupational specialty, the LOC only serves to familiarize the student on a medley of diverse occupational subjects beneath the broad, yet vague, umbrella called *logistics*. Additionally, the condensed, non-specific initial training course seems incompatible with the duties the 0402

⁵⁹ Ground Supply Officer Course (GSOC) (M03C0G1) dated 6 February 2013.

logistics officer will be required to perform with a high level of expertise. As such, there is no clear line linking formal learning to duty assignment. Rather, it appears that the LOC graduate can find themselves in any one of many diverse billets mentioned in the MOS Manual or MOS Handbook with only a few weeks of subject familiarity.

This is best described by examining a single billet where the 0402 logistics officer could likely be assigned - the battalion Maintenance Management Officer (MMO). Within the LOC, maintenance management formal training consists of a single terminal learning objective (TLO): *0402-OPS-1005, Perform the duties of a maintenance management officer, to ensure the effective use of personnel, money, facilities, and material as applied to the maintenance of ground equipment is controlled.* There are 140 enabling learning objectives (ELOs) supporting this single learning objective, which is taught within 18 separate lessons (66 hours (equating to a new learning objective every 28 minutes)) and four comprehensive examinations (21.5 hours).⁶⁰ As such, with approximately eleven days of explicit maintenance management officer training, the 0402 MOS graduate is assigned as the battalion MMO and charged with overseeing, supervising, and ensuring the accountability of all the battalion's maintenance management functions. No follow-on formal training is available; therefore the newly christened 2ndLt's success is determined by what they recall from LOC or from what they gain from

⁶⁰ Only one exam exclusively tests for mastery of learning objective 0402-OPS-1005 - 305X (1 TLO/36 ELO). The other three examinations include non-0402-OPS-1005 lesson material: 109X - 4 TLO/53 ELO; 209X - 4 TLO/18 ELO; and 410X - 2 TLO/7 ELO.

superiors, peers, subordinates or policy - which is not standardized across the Marine Corps and therefore haphazard at best.

What is also difficult to understand is the subsequent yet indiscriminate reassignment of the 0402 logistics officer after a year or so performing in a particular billet. It seems that once the 0402 logistics officer begins to gain sufficient competency - by employing billet specific skill sets - they are reassigned into another billet that may not even vaguely resemble the tasks they were recently performing. In this situation, the 0402 logistics officer is again dependent on other Marines knowledge or the training received in the entry-level LOC - that may now only be a hazy memory.

To amplify this point, consider the 0402 logistics officer who has just served 18 months as the battalion MMO and is then assigned as the battalion landing support platoon commander. Reviewing the LOC identifies a single terminal learning objective - *0402-OPS-1009, Given the requirement to plan landing support and throughput operations, perform the duties of a landing support platoon commander, to support the unit's mission and the Commander's concept of operations.* This single TLO includes 27 ELOs presented within nine one-hour lessons, a 4-hour demonstration, and a single 4.5-hour written exam. There are also three practical application/coaching sessions (71 hours) although the lesson material is not exclusively landing support. All told, well over a year prior, the individual received roughly eleven days of training (88.5 hours) - related to their new billet assignment.

What is apparent by the lack of occupationally specific training is that the 0402 MOS fails to consider *logistics* doctrine that

emphasizes that successful and effective logistics capabilities are “developed through continuous, progressive, and challenging training” (MCDP 4, pg. 108). There is no continuous or progressive training for the 0402 Logistics Officer MOS; instead, there is only the single entry-level LOC.

In regards to challenging training, in the years 2000 through 2012, the LOC graduated 2,164 students with an overall class average of 94.76 percent. Out of 62 LOC classes, only five students (.23%) were recycled and eventually graduated (two for medical conditions and three for academic reasons) while only a single student (.05%) attrited from the course due to administrative separation. Consequently, it seems inappropriate to apply the term challenging to any formal course that for over 13 years graduated 99.95 percent of the students that arrived for training, while simultaneously maintaining an average GPA of 94.76 percent.

On a positive note, the LOC does convene six 56-day class iterations to meet the projected annual student throughput of 240 students. With only 228 available training days,⁶¹ the LOC must overlap classes by 147.4% to meet the required 336 training days. While this is encouraging, the instructor (18) to student ratio (240) equals one instructor for every thirteen students, which is considerably lower than the majority of formal courses that employ a 1:30 or 1:40 ratio. This ratio drops significantly to a 1:4 ratio (equaling one instructor to 3.47 students) when the additional 51

⁶¹ (see Footnote 19)

instructor support personnel identified in the LOC CDD (shown in Figure 12)⁶² are included.

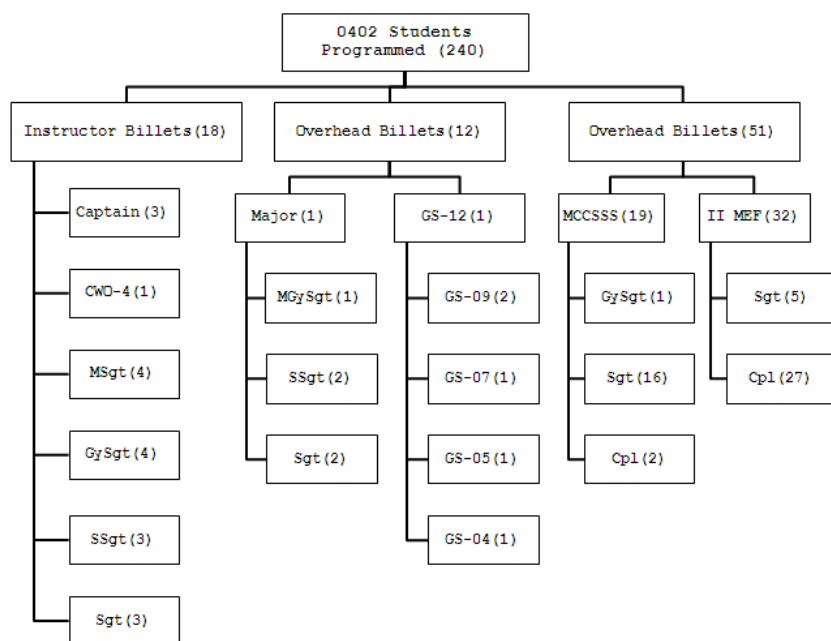

Figure 12 Logistics Officer Course (LOC) Required Personnel

Regardless of statistical ratios, a simple review of the LOC CDD reveals that 296.6 hours, nearly 70 percent (67.26%) of the course, is taught with less than three instructors, as shown in Figure 13. Specifically, 32.9 percent (143 hours) of the course requires a single instructor, 21.73 percent (95.1 hours) requires two instructors, 13.37 percent (58.5 hours) requires three instructors, and 8.23 percent (36 hours) requires four instructors. The field exercise, coaching, and some practical application do require five instructors for 56 hours (12.80%) and eight instructors for 48 hours (10.97%).

⁶² Fifty-one instructor support billets (1 E-7, 7 E-5, and 43 E-4) support the LOC tactical convoy and the FEX. Both events are supported by MCCSSS (18) and II MEF (34) via Naval Message request.

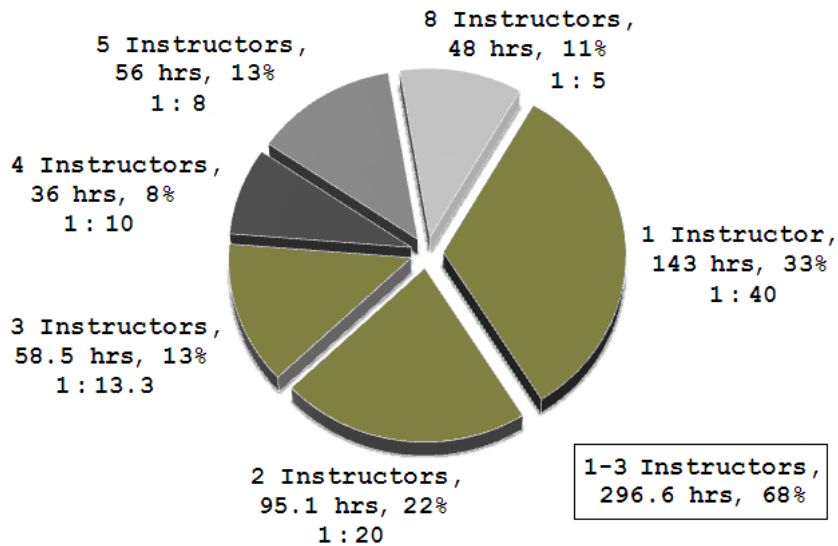

Figure 13 LOC Instructor to Student Ratios by Hours and Percent

With eight instructors being the most required to safely and effectively train - for at most 11 percent of the course - and 55 percent of the course (238.1 hours) being administered by one or at most two instructors, the requirement for 18 instructors and 51 instructor support personnel seems hard to defend - even with roughly half of the classes overlapping.

One final concern was recognized during the review of the LOC supporting documents, specifically related to the American Council of Education Military (ACE) Guide (<http://www.militaryguides.acenet.edu>). As background, formal military course accreditation begins with a review by professional educators working with the ACE who, after a comprehensive evaluation of all course materials, make recommendations for collegiate credit. Table 38 reports the collegiate credit recommended for the LOC, as well as other CSS related courses, as they are reflected in the ACE Military Guide.

Table 38 American Council of Education (ACE) Recommendations

CID	Title	Active Dates	Credit Recommendations	Total Credits
M03C0G1	Ground Supply Officer	10/05-Present	5 semester hours in supply management	5
M03FNH0	Financial Management Officer	2/05-Present	4 semester hours in computer software applications and 4 hours in fund accounting	8
M03LAV7	Logistics Officer	12/98-11/11 (Expired)	6 semester hours in maintenance management, 3 in motor transportation operations, and 3 in logistics	12
M03MBJ7	Motor Transport Maintenance Officer	5/99-Present	3 semester hours in automotive service management, 2 in operations management, and 1 in heavy equipment maintenance	6
M03ACC2	Engineer Officer	6/03-Present	3 semester hours in basic construction materials and methods, and 3 in construction management	6

What was curious is that while the LOC provides the highest number of collegiate credits (12 semester hours) it is the only course where accreditation has lapsed - as of October 2011. For the course's accreditation to be revoked is surprising as previously noted LOC CDD resource documents (Figure 12) identify 81 subject or process experts supporting the oversight, design, development, piloting, implementation, and evaluation of course curriculum.

Training and Readiness (T&R) Events

Like all of the 04XX MOSs examined, there is no differentiation in the 1000-level performance expectations of 2ndLts, 1stLts, and captains (one event includes majors) or in the 2000-level behaviors written for captains, majors, and LtCols (one event "perform a personnel jump from an aircraft" includes 0402 2ndLts and 1stLts) as the 0402 T&R Manual directs *identical behaviors under the same*

conditions using the same performance standards - regardless of rank.

The 15 1000-level and 12 2000-level 0402 T&R events are shown in Appendix O.

The 04XX T&R Manual directs all 1000-, and 2000-level 0402 MOS T&R events to be taught via *formal* training; therefore, no guidance is provided for MOJT administration or evaluation. This is contrary to logistics doctrine that directs unit and collective training to develop "teamwork while mastering the tactics and techniques required to provide effective support" (MCDP 4, pg. 108). As such, it seems unlikely that 1stLts, captains, majors, and LtCols in the 0402 MOS will meet required T&R event evaluation or receive formal training when no formal course - or MOJT guidance - exists.

There is one other relevant point of interest concerning the 0402 T&R events that is difficult to comprehend or rationalize. Upon review, it becomes readily apparent that for all practical purposes many of the T&R events written for the 0402 *logistics officer* are nearly identical to those of the 0491 *logistics chief* - less the interchangeable action verb used to describe behavior⁶³ as presented in Table 39.

⁶³ One 0402 MOS T&R event was not included in the 0491 MOS T&R events; 0402-OPS-2001: Perform a personnel jump from an aircraft for 2ndLts, 1stLts, captains, majors and LtCols in the 0402 and 0405 MOSs.

Table 39 Comparison of 0402 and 0491 MOS T&R Events

0402 Logistics Officer	0491 Logistics Chief	Event
0402-ENG-1001: Coordinate	0491-ENG-2001: Coordinate	general engineering support
0402-HSS-1003: Coordinate	0491-HSS-2003: Coordinate	health services support
0402-MNT-1004: Coordinate	0491-MNT-2004: Coordinate	maintenance support
0402-SUP-1013: Coordinate	0491-SUP-2009: Coordinate	supply support
0402-SVC-1014: Coordinate	0491-SVC-2010: Coordinate	services support
0402-TRAN-1015: Coordinate	0491-TRAN-2011: Coordinate	transportation support
0402-OPS-2005: Coordinate	0491-OPS-2007: Coordinate	a unit move
0402-OPS-2006: Manage	0491-OPS-2006: Manage	unit training
0402-OPS-2008: Plan	0491-OPS-2005: Coordinate	amphibious operations
0402-OPS-2007: Direct	0491-OPS-2008: Participate in	the Marine Corps Planning Process (MCP)
0402-GEN-1002: Perform		the general duties of a logistics officer
	0491-GEN-2002: Perform	the general duties of an LCE operations chief

If accepted as written, it appears that the 0402 *logistics officer* performs over 40 percent (11 of 27) of the same duties to the same standards and under the same conditions as the 0491 *logistics chief*. This implies that the expected performance behaviors for GySgts, MSgts, and MGySgts in the 0491 MOS are fundamentally the same as what is expected of 2ndLts, 1stLts, captains, majors, and LtCols in the 0402 MOS. The chief concern becomes obvious when the MOS-performance guiding document fails to differentiate between the actions of officers and enlisted personnel it becomes difficult to justify the need for upward mobility or a comprehensive promotion system.

Selection Rate

Unlike the enlisted ranks that include TIG and TIS of the specific MOSs considered, unrestricted officers are considered against all other MOSs. Depending on the needs of the U.S. Marine Corps,

unrestricted officer promotion boards will consider officers from three categories, the above-zone, in-zone, and below-zone. As part of the selection board process, an administrative message is drafted and published identifying the date of rank of the senior and junior officers (as determined by their lineal control number) thereby creating a consideration zone for all officers falling within. Officers predetermined as active-duty on the date the selection board convenes are eligible for considerations less any that have established separation or retirement dates or were previously considered for selection. Upon conclusion of the normal promotion board, a continuation board is convened with additional clarifying guidance for continued service of individuals who were not selected for promotion but are in critical MOSs.

Therefore any differences in the selection rate of 0402 logistic officers that may exist - when compared to all other MOSs - could only be explored by examining the selection rates of all captains, majors, and LtCols. As discussed previously, the 04XX MOS is the seventh largest MOS with the 3rd largest officer population and the 13th largest enlisted population; therefore, it comes as no surprise that 0402 MOS captains, majors and LtCols accounted for the third most selected MOSs. What is curious though is that in the years 2005 through 2013, the 0402 MOS selected a higher average percentage of eligible officers (99.20%) than the average percent selected by all other MOSs (98.73%). Table 40 reports the unrestricted captain selection for the years 2005 through 2013 by MOS, the number of 1stLts

considered and selected for promotion, and the selection percentage and ranking.

Table 40 Unrestricted Captain Selections by MOS

Field	Captain MOS Description	Con	Sel	% Sel	Rank by % Sel
44XX	Legal Services	370	370	100.00%	1
43XX	Public Affairs	118	118	100.00%	2
75XX	Pilots/Naval Flight Officers	3540	3524	99.55%	3
66XX	Aviation Logistics	195	194	99.49%	4
08XX	Field Artillery	825	820	99.39%	5
04XX	Logistics	1245	1235	99.20%	6
13XX	Engineer	466	462	99.14%	7
02XX	Intelligence	1094	1084	99.09%	8
72XX	Air Control	572	565	98.78%	9
ALL	All MOSs	12004	11851	98.73%	10
06XX	Communications	941	929	98.72%	11
58XX	Military Police	218	215	98.62%	12
34XX	Financial Management	214	211	98.60%	13
18XX	Tank and Assault Vehicles	279	275	98.57%	14
03XX	Infantry	1957	1915	97.85%	15
30XX	Supply	554	541	97.65%	16
60XX	Aircraft Maintenance	231	225	97.40%	17
01XX	Personnel & Administration	403	386	95.78%	18
80XX	Miscellaneous	24	16	66.67%	19
99XX	Miscellaneous	3	1	33.33%	20

The data indicates that 1stLts in all MOSs were selected for captain on average 98.73 percent of the time; whereas, nearly all 1stLts (99.20%) in the 0402 MOS were selected for captain. While the percent difference may seem insignificant [99.20% - 98.73% = .47%] the distinction when converted to actual personnel reveals that while 153 1stLts from all MOSs that were not selected, only ten 1stLts in the 0402 Logistics Officer MOS were not. Additionally in five of the nine years the 0402 Logistics Officer MOS selected every eligible 1stLt for captain (100%).

Table 41 reports the unrestricted officer major selection data for the years 2005 through 2013. Of the 13,269 captains considered

for major, 5,521 were selected in all MOSs (41.61%), whereas, of the 1,146 captains considered in the 0402 MOS there were 490 majors selected (42.76%). While the average percent of 0402 captains was higher than the average percent reflected for all MOSs, it was also higher than 12 other MOSs, including the supply (42.68%), engineer (42.46%), and aviation pilot and Naval Flight Officer (39.94%) MOSs.

Perry (2006) utilized logistical regression to determine if specific MOSs were promoted at a significantly higher rate when all other factors were considered and controlled. His findings indicate that a captain in the 0402 MOS was 3.83 percent more likely to be selected for major compared to all other MOSs with comparable attributes. Perry also noted that the odds of a captain in the 0402 Logistics Officer MOS being promoted to major were 31.6 percent greater compared to a captain in the 0302 Infantry Officer MOS with comparable attributes.

Table 41 Unrestricted Major Selections by MOS

Field	Major MOS Description	Con	Sel	% Sel	Rank by % Sel
18XX	Tank and Assault Vehicles	256	119	46.48%	1
08XX	Field Artillery	640	297	46.41%	2
58XX	Military Police	166	77	46.39%	3
03XX	Infantry	1590	729	45.85%	4
60XX	Aircraft Maintenance	277	119	42.96%	5
04XX	Logistics	1146	490	42.76%	6
30XX	Supply	649	277	42.68%	7
66XX	Aviation Logistics	209	89	42.58%	8
13XX	Engineer	358	152	42.46%	9
44XX	Legal Services	539	228	42.30%	10
34XX	Financial Management	306	128	41.83%	11
ALL	All MOSs	13269	5521	41.61%	12
06XX	Communications	888	369	41.55%	13
02XX	Intelligence	953	386	40.50%	14
75XX	Pilots/Naval Flight Officers	5335	2131	39.94%	15
01XX	Personnel & Administration	486	186	38.27%	16
72XX	Air Control	479	183	38.20%	17
43XX	Public Affairs	137	51	37.23%	18
80XX	Miscellaneous	1	0	0.00%	19

Table 42 reports the unrestricted officer LtCol selection data for all MOSs for the years 2005 through 2013. Of the 13,216 majors considered for LtCol, 3,041 were selected (23.01%) for all MOSs while in the 0402 MOS, 263 LtCols were selected from the 1,089 majors considered (24.15%). Like the captain and major results, the percentage of 0402 LtCols selected for promotion is higher than the average percent shown for all MOSs, as well as the 30XX supply, 13XX engineer, 06XX communication, 02XX intelligence, and the 75XX pilot/Navy Flight Officer occupational fields.

Table 42 Unrestricted LtCol Selection by MOS

Field	LtCol MOS Description	Con	Sel	% Sel	Rank by % Sel
99XX	Miscellaneous	63	40	63.49%	1
44XX	Legal Services	394	117	29.70%	2
03XX	Infantry	1741	504	28.95%	3
02XX	Intelligence	655	173	26.41%	4
01XX	Personnel & Administration	246	62	25.20%	5
13XX	Engineer	388	97	25.00%	6
08XX	Field Artillery	708	173	24.44%	7
04XX	Logistics	1089	263	24.15%	8
18XX	Tank and Assault Vehicles	303	72	23.76%	9
ALL	All MOSS	12190	2818	23.12%	10
34XX	Financial Management	220	50	22.73%	11
66XX	Aviation Logistics	165	36	21.82%	12
72XX	Air Control	432	93	21.53%	13
60XX	Aircraft Maintenance	193	41	21.24%	14
30XX	Supply	548	116	21.17%	15
43XX	Public Affairs	136	28	20.59%	16
75XX	Pilots/Naval Flight Officers	5174	1050	20.29%	17
06XX	Communications	703	142	20.20%	18
58XX	Military Police	121	24	19.83%	19

Discussion and Future Considerations

Overall, this analysis finds the 04XX logistics occupational field plagued by shoddy guiding documents, amplified by inattention and neglect that has led to widespread generalization and unnecessarily redundant resource allocations. Individual MOSSs lack specialized substance, thereby, becoming so generic that anyone from any MOS is capable of performing the tasks with little or no familiarization. Having been built upon faulty foundational concepts, while concurrently trying to absorb all of the functions once reserved for well-established legacy MOSSs, the 04XX logistics field is rife with blurred roles and associated performance goals, which allow MOSSs to merge at the higher ranks without any appreciable subject expertise in the combining occupational specialties. Without clearly defined and exclusive subject matter expertise, operational success becomes

personality driven - vice process driven - and dependent on insulated policy and procedures that retard individual initiative for mediocre performance. As such, the greatest failure of the U.S. Marine Corps logistics model has been its complete indifference to the true role of *logistics*.

This analysis became extremely difficult simply because of the intangible and ambiguous nature of conceptual *logistics*. A unified conceptual definition of logistics is difficult as many consider logistics to be as much science as art. Some believe logistics to be an essential component of process success while others consider it only a bureaucratic burden. Others consider logistics to be a specialized occupation while an equal number conversely believe it to be only a generalized hindrance. With the wide latitude of accepted beliefs, logistics has ultimately become an ill-defined collection of functions that every individual in the organization must perform regardless of their occupational specialty. Unlike the succinctly defined occupational fields of supply, disbursing, and maintenance - the ever-pervasive generality of logistics makes it the poster child of omnipresent ambiguity.

The Marine Corps' logistics model has lost sight of "reducing risk for profit" and "eliminating waste" and has instead become the all-encompassing - yet generic - usurper of all combat service support elements. As an objective observer reviewing current doctrine, formal MOS guidance, T&R events, and formal school curriculum, there appears to be an implicit directive to eliminate all *combat service support*

terminology in lieu of *logistics*; although, the defining factors, functions, and sub-functions for the most part remain the same.

Where *Combat Service Support (CSS)* was once a proud and distinguished field filled with expertly trained specialists within very explicit vocations led by mature and experienced noncommissioned and commissioned officers who understood, accepted, and took pride in their support roles, we now have *logistics*, a hodgepodge of vaguely similar staff functions performed by generalists with little experience or subject matter expertise. While CSS was a clearly defined conceptual construct that enhanced immediate comprehension; *logistics* is just the opposite - an ambiguous, imprecise, and ill-defined schema that remains both all-inclusive and minimalistic.

What makes this most confusing is the fact that the U.S. Marine Corps is fundamentally divided into two groups - those who fight (combat) and those who support (combat service support). Without the warfighter there would be no need for support; whereas, without support the warfighter would be unable to fight. Although simplistic, both are essential and critical to operational success and both are equally important - for without one there could be no other.

Simply stated, the model cannot be those who fight (combat) and those who generalize (*logistics*) because all the functions of *logistics* (manage, coordinate, organize, plan, strategize, etc.) are also performed equally by the warfighter - and not vice versa - the logistician cannot perform the tasks of the warfighter. To support these conclusions, each 04XX MOS analyzed is reintroduced with subjective recommendations presented for consideration.

0411 Maintenance Management Specialist

First and foremost, the need for a 0411 MOS-specific entry-level course remains unsubstantiated for at least three significant reasons. First, per the MOS Manual, the 0411 Maintenance Management Specialist MOS can be awarded at the commander's discretion to any Marine as an alternate MOS after six-months of duty and completion of two Marine Corps Institute (MCI) distance-learning courses. Second, the required 0411 T&R performance behaviors are the same for an entry-level private as they are for the 0411 LCpl, Cpl, and Sgt; whereas, the T&R performance events required for 0411 Cpls direct mastery of the *same tasks to the same standards under the same conditions* as those required of the 0411 MGySgt. Finally, the MOS Manual directs completion of only a single, or at most two, formal course(s) to gain and sustain the 0411 MOS performance standards (excluding the commander's ability to assign the MOS mentioned previously) while the 0411 T&R Manual directs no skill-progression MOJT. Consequently, this means that all of the knowledge, skill, and supervised practical application necessary for an individual to successful progress through the 0411 Maintenance Management MOS ranks - private through MGySgt - is presented in at most two 20-day formal courses or at minimum two distance-learning courses.

Taken in context, the obvious question remains that if an individual can successfully serve an entire 20-year enlisted career with only 40 days of formal instruction or two distance-learning courses, why couldn't this MOS be assigned exclusively as a secondary MOS? By simply eliminating the need for a formal course (and

associated formal school overhead) would result in significant resource savings in staffing alone - as the current BMMSC CDD identifies six instructors and 12 support staff that utilize roughly half of the calendar year (54.6%) to train students.

By extension if there is no need for a formal course or formal school, as the required performance events have shifted to a secondary role, there would logically be no need for uniquely 0411 Maintenance Management MOS-specific structure. Eliminating the MOS altogether would allow the current structure of 1,709 0411's to be realigned into other similar MOSs - like the 3043 MOS - to support the implementation of GCSS-MC. This would result in one less MOS to recruit, promote, reenlist, develop performance standards, etc., which in turn would reduce the number of support personnel who could then be reassigned to manage other more-critical projects.

0431 Logistics/Embarkation Specialist

This analysis has shown that over 25 different MOSs perform embark-related functions within their individual occupational specialties - usually with embark training being received via MOJT or on-site. Specifically, the 0431, 3051, 3052, & 3043 occupational specialties all perform nearly identical "supply-logistics-related" functions; i.e., prepare, provide, and operationally handle supplies and equipment for movement and distribution, albeit to differing degrees. All generate manifests, conduct inventories, and manage records and publications. All identify and segregate classes of supply and plan, validate and inspect storage areas. All mark, label, and certify containerization for storage or shipment. All report

serviceability and monitor hazardous materials. All utilize material handling equipment and automated tracking hardware, to include RFID tags.

As the 3051, 3052, and 3043 MOSs all have primary duties related to the storage, packaging, movement, record keeping, and tracking of commodities, there appears to be nothing particularly uncommon that sets the 0431 MOS apart from the others. Simple definitions deflate the exclusivity as the term *Embark* meaning "to board a ship, aircraft or other vehicle" as the term *Transport* meaning "to carry, move, or convey from one place to another" while *Supply* means "to furnish or provide a person, place, item, to what is lacking or requisite".

The ensuing question would naturally be what are the unique attributes of the 0431 Logistics/Embarkation MOS that require a separate occupational field - complete with formal school training tracks, promotion & career plans, billet assignments, and occupational sponsors? An honest observer would conclude that for all practical purposes, the only noticeable differences - beyond jargon - appear to be self-inflicted to meet historical precedence, isolated stove-piped tasks, or specifically-unique system requirements (both hardware and software) procured to further insulate the MOS from other "supply-logistics-related" MOSs. The logical follow-on question would be that even if the 0431 MOS was rife with unique functions that set it apart from other MOSs, why couldn't those unique qualities be included within the 30XX occupational field - thereby reducing the overhead support structure required to sustain an independent MOS?

As eliminating redundancies is the cornerstone of "logistics" an objective review of the 0431 MOS, to first identify and then eliminate repetitive processes and redundant materials, should be conducted if for no other reason than to validate current organizational structure. Notwithstanding the anticipated push-back from institutionalized personnel and processes, any 0431 MOS-specific functions - not duplicated elsewhere - could be isolated and assimilated into the 3051 or 3043 MOSs. While it could be argued that combining MOSs would likely increase the required number of training days and consequently increase class iterations and associated instructional staff, the fact remains that the six instructors (1-CWO3, 1-GySgt, 3-SSgt, 1-Sgt) and 11 support staff (1-Maj, 1-CWO3, 1-MSgt, 1-SSgt, 1-Cpl, 2-LCpl, 1-GS12, 1-GS9, 1-GS5, and 1-GS4) identified in the BLESC CDD⁶⁴ as required to train entry-level students, only utilize 58.3 percent (133) of the 228 available training days. Therefore, while combining the MOSs could increase the existing 30XX training pipeline to accommodate the added material, the potential overall savings gained by simply eliminating the duplicative, resource-expensive, organizational overhead would certainly be worth investigating.

0481 Landing Support Specialist

A critical analysis of the 0481 MOS resource documents creates a disturbing image of inattention and neglect. It is difficult to excuse multiple deficiencies as "simple administrative oversights" when: a) the T&R Manual fails to differentiate by rank, any of the 1000-, or 2000-level performance events; b) the MOS Manual identifies

⁶⁴ (see Footnote 21)

either no progressive 0481 MOS-specific required training or the requisite 0481 training is *identical* to the training required of the 0431 MOS (less PME); c) that the 0481 MOS T&R events fail to match the learning objectives presenting in the formal MOS-generating, entry-level BLSSC;⁶⁵ d) many of the 0481 T&R events are very similar to the those of the 3043 and 3051 MOSs; or e) that it took at least six-years to correctly identify the 0481 formal school location as MCCSSS in the *annually* reviewed MOS Manual.

These actions - or inactions - reflect a pattern of either extreme indifference or worse considerable ineptitude on the part of formal school 0481 training managers, occupational field sponsors, and operational force reviewers. By not competently reviewing not only the MOS Manual, but also the 04XX T&R Manual, the annual TIP Training Tracks, and the formal school curriculum, their performance reflects poorly on the 0481 Landing Support Specialist MOS as a whole.

With this lack of attention to detail (or worse ineffective apathy) the question remains - from a purely process-orientated, resource-management perspective - why is there a unique MOS when the majority of MOS performance events are very similar to those found within the 3043 and 3051 MOSs? Furthermore, would it not be more cost effective to incorporate the performance differences into existing MOSs (like the 3043 or 3051 MOSs) than to maintain an entirely separate and distinctly different MOS? Or if need be, create another MOS within the 30XX Ground Supply occupational field to greatly reduce the organizational structure, redundant billets, and underutilized

⁶⁵ (see Footnote 26)

formal school overhead while streamlining training and MOS development processes by ultimately reducing unnecessarily over-specialized occupational fields.

0491 Logistics/Mobility Chief

Essentially, the 0491 MOS is comprised of two dissimilar MOSs that originally performed vastly different tasks, until sufficient time has elapsed to warrant promotion to GySgt - when they are immediately enthroned to be masters of both. What makes the 0491 MOS particularly unusual is the overt dissimilarity to other more-technical occupational fields. In highly specialized fields earning the title "Chief" implies a detailed understanding of every common facet associated with a specific occupational field even though they may have begun their careers compartmentalized in a single functional area.

As a case in point, the 6391 Avionics Maintenance Chief MOS begins their career as a technician in the 63XX occupational field performing in a wide range of functional areas ranging from communications, RADAR, or navigational systems on a variety of aircraft, including the AV-8 Harrier, EA-6 Prowler, KC-130 Hercules, F/A-18 Hornet, CH-46 Sea Knight, CH-53 Super Stallion, etc. What makes the 6391 aviation maintenance chief successful is the foundational knowledge (electronic theory, system components, wiring diagrams and schematics, etc.), techniques (troubleshooting, test equipment, corrective maintenance, etc.), and procedures (supply system, preventive maintenance, service requests, etc.) that remain nearly identical across the entire gambit of occupationally related MOSs.

Once promoted, the 6391 aviation maintenance chief is considered the epitome of the 63XX occupational field, an expert at diagnosing faults and problem identification, interpreting schematics and processes, evaluating equipment performance, scheduling maintenance, preparing maintenance forms and supply requisitions, and overseeing test equipment, specialized tools, and technical libraries. This highly technical model supports the concept that similar MOSs can merge into a single senior supervisory role but only if there is a common foundational knowledge coupled with an understanding of heavily related system and hardware processes.

Therefore, when a "Chief" from a highly technical field is promoted it is based on their demonstrated expertise within their respective field where they have progressively moved upward through the ranks gaining MOS credibility specific to their occupational field. Unfortunately, in the 0491 MOS promotion to "Chief" is more a product of longevity and available vacancies within the senior ranks, a term the British call "Buggin's Turn" meaning *promotion by seniority or rotation* rather than merit.

Compared to highly technical MOSs, it seems unrealistic to believe that when a SSgt from either the 0431 Logistics/Embarkation Specialist MOS or 0481 Landing Support Specialist MOS is promoted to GySgt they are suddenly imbued with the implied content expertise of both MOSs. It also seems improbable that the newly minted 0491 logistics mobility chief would also suddenly gain the combined subject expertise of all logistics and mobility functions within the Logistics Combat Element (LCE) - at a level sufficient to be responsible for all

combat logistics functions required to deploy and sustain the MAGTF and its attached units.

In regards to formal training, the 0491 MOS has simply elected not to attend mandated formal training. Specifically, over the last decade, the CSSC graduation numbers indicate that only twenty-five percent (24.97%) of the 0491 programmed formal course seats were filled. It goes without saying that when student numbers are inaccurate, or significantly and consistently fall short of projected goals, appropriate distribution of resources and personnel is impossible. To reiterate, the ALMC⁶⁶ CDD lists six instructors (1-Maj, 1-Capt, 1-CWO5, 1-MSgt, 1-GySgt, and 1-SSgt) and seven support staff (1-GS12, 1-GS11, 1-GS9, 1-GS5, 1-GS4, 1-E5, and 1-E4) as required to train two 15-training day iterations for 80 students, annually. It becomes readily apparent by reviewing the 0491 MOS formal school attendance rates, that the formal school has equipped and maintained largely empty classrooms and facilities, while concurrently employing personnel (both military and civilian) to spend hundreds if not thousands of hours developing curriculum that was rarely utilized. Although what is most inexcusable is that the formal school has been staffed not only to train the additional 556 students *that never arrived*, but has also created and filled senior leadership billets to oversee training *that never occurred*. Beyond what appears to be a simple matter of mismanaging resources, it could also be easily argued that instead of filling comfortable, three-year-long, non-deploying, underutilized, and apparently, nonessential billets that formal school

⁶⁶ (see Footnote 31)

assignment of senior personnel could have been better utilized in the operating forces - if only to relieve some of the deployment burden felt by others within the occupational field.

Like the other 04XX MOSs explored, the 0491 MOS suffers from the same lack of T&R performance differentiation. Expecting identical performance of GySgts, MSgts, and MGySgts implies there is no difference between the three ranks - which remains practically and significantly implausible. If this really were the case, there would be no need for a promotion system. It is also curious that every 2000-level 0491 T&R event is not exclusive to the 0491 MOS. Instead, critical 0491 Logistics/Mobility Chief MOS performance behaviors are also assigned to the 1371 Combat Engineer, 3043 Supply Administration and Operation Chief, and the 3537 Motor Transport Operations Chief MOSs - *within the 04XX T&R Manual* (pgs. 14-4/13). This generality also introduces another issue concerning exactly who - by MOS - fills the billet of logistics chief in the operating forces.

Most senior SNCO's would be quick to say that the logistics chief billet is not exclusive to the 0491 MOS, but that the billet is filled based on who the command element considers to be available and capable. Therefore, if the logistics chief billet can be filled by any CSS MOS (or any competent SNCO) then the critical performance behaviors become so generic as to eliminate any exclusivity to the 0491 MOS. Without this exclusiveness, there would be no justifiable need for the 0491 MOS as specific logistics chief functions and associated skill-sets could be developed to fulfill MOS-generic staff

billet requirements in a manner similar to the 8016 Special Technical Operations MOS.

Taken together, instead of demonstrating progressively advanced technical proficiency leading to exclusive MOS credibility, the 0491 MOS appears to have simply been created to fulfill the need for continued advancement in the enlisted 04XX occupational field.

0430 Mobility Officer

This analysis uncovered significant and problematic MOS design flaws coupled with a lack of adequate oversight and unrealistic performance expectations concerning the 0430 Mobility Officer MOS. The 0430 MOS as a whole appears to be successful - as indicated by productive billet assignments and subsequent promotions, although both are likely highly self-promulgating and MOS-centrally reinforced within the MOS. Rather, after analysis, this reviewer proposes that any specific 0430 Mobility Officer MOS success is more likely a product of individual ability and personal initiative vice any coherent organizational model designed to ensure MOS success.

The 0430 Mobility Officer MOS - like the equally perplexing 0491 Mobility Chief MOS - is fed by distinctly different enlisted feeder MOSSs. The 0430 Mobility Officer MOS is the career progression trek for the enlisted 0431 Logistics/Embarkation Specialist MOS, and by simple occupational field association the 0411, 0451, and 0481 MOSSs. What is most surprising is that the 0430 MOS also serves as a career track for a wide assortment of other MOSSs even though their initial enlisted MOS appears to have little or no relationship with mobility expertise.

In most occupational fields, a clear line can be drawn from the enlisted MOS through NCO and SNCO, and warrant officer and LDO MOSs. For example, the 5902 Electronics Maintenance Officer Aviation Command and Control (C2) LDO MOS can be logically traced to one of three 59XX Maintenance Officer MOSs, which are fed exclusively by four enlisted 59XX technician MOSs. Figure 13 demonstrates the commonsense approach that allows for enhanced continuity within closely related fields that share identical procedures, policies, doctrine, and skill sets. This systematic and rational approach does not appear to be the case for the 0430 Mobility Officer MOS.

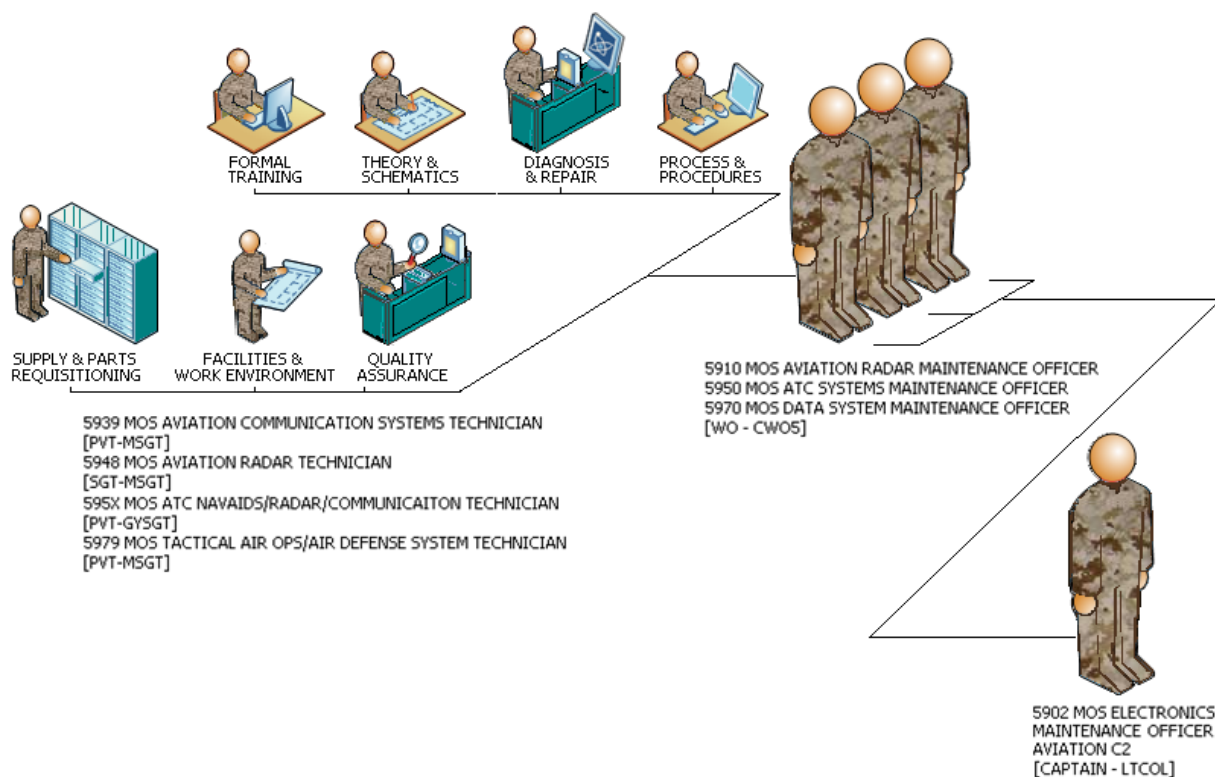

Figure 14 Career Progression of a Highly Technical MOS (5902 MOS)

A review of the known feeder MOSs (including those that fed into the 0491 MOS) reveal that the majority of warrant officers (70.40%)

were originally from the enlisted 0431 Logistics/Embarkation Specialist MOS (157 of the 223) and another 18.39 percent (41 of 223) came from the 0481 Landing Support Specialist MOS. The remaining twenty-five selections (11.21%) were selected from eleven diverse MOSs⁶⁷ revealing an overall lack of MOS-specific foundational expertise in the 0430 MOS. Figure 14 demonstrates the dissimilarity of MOSs that fed into the 0430 MOS.

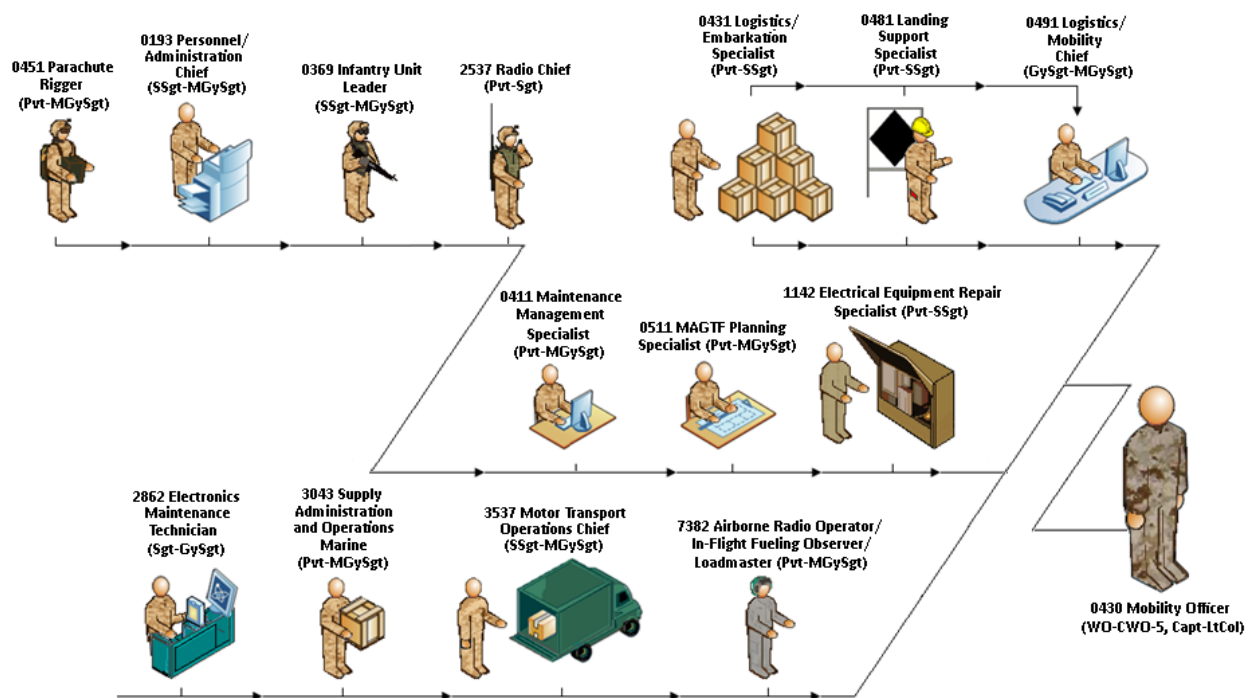

Figure 15 Career Progression within the 0430 MOS

Specifically, eight 0430 warrant officers were selected from the 0511 MAGTF Planner MOS (3.58%), another three were selected from the 3537 Motor Transport Operations MOS (1.34%), and another two were selected from the 7382 Airborne Radio Operator/Loadmaster MOS (.89%). The final eight warrant officers (3.58%) were selected from eight

⁶⁷ Four feeder MOSs (1.79%) could not be identified.

distinctly different occupational specialties, the 0193 Personnel Administration Chief, 0369 Infantry Unit Leader, 0411 Maintenance Management Specialist, 0451 Parachute Rigger, 1142 Electrical Equipment Repair Specialist, 2537 Radio Chief, 2862 Electronics Maintenance Technician, and 3043 Supply Administration and Operations Specialist MOSs.

As every occupational field possesses different skills, knowledge, and experience, selecting applicants from other occupational fields - other than the 0431 MOS - seems irrational and ultimately deleterious to the occupational field as a whole. It also disregards current selection board guidance that describe warrant officers as the "technical specialist that require extensive knowledge of a particular MOS" and where "MOS credibility is a key factor for selection".⁶⁸ This is particularly relevant when the MOS Manual describes the key function of the 0430 mobility officer is to "provide interface and articulate the strategic mobility requirements both present and future to appropriate agencies, such as, Headquarters Marine Corps, U.S. Transportation Command and her three Transportation Component Commands (TCCs); Surface Deployment Distribution Command, Military Sealift Command, and Air Mobility Command" (pg. 1-22).

Like the 0491 Mobility Chief MOS, instead of being necessary for selection, it seems the preeminent technical knowledge, exceptional subject expertise, and voluminous experience are *bestowed upon selection* to be haphazardly groomed by seniors and subordinates thereafter. This implies that mobility expertise can be learned by

⁶⁸ (see Footnote 34)

anyone from any MOS *after promotion* to be expanded upon through the chief warrant officer and LDO ranks. This model is contradictory to the clearly defined expertise - gained through years of progressive growth and increased responsibility shown in the 5902 Electronic Maintenance Officer Aviation C2 MOS.

In regards to formal training, it remains somewhat disconcerting that over the last seven years, only three out of four 0430 mobility officers have managed to graduate from *mandatory* training or that anything less than 100 percent completion of requisite training - *required to gain the 0430 Mobility Officer MOS* - has become acceptable and commonplace. It is equally disturbing that half (50.9%) of the Training Command identified TIP quotas were inaccurate, that 60 percent of CDD resources were misidentified as requirements when they were not, and that quotas and resources continued at visibly inaccurate levels without accountability, oversight or justification. As discussed previously, formal learning center (FLC) operations is extremely expensive in personnel (instructor, staff, and support), facilities (classrooms, instructor workrooms, barracks, etc.), and resources (training and computer devices, reproduction, operating costs, student travel costs, etc.). Formal school leadership must be held accountable to avoid misappropriating resources by accurately reviewing and validating TIP quotas in order to justify formal school seat allocations - and subsequent personnel, facilities, budgets, and overhead. In regards to the 0430 Mobility Officer MOS the required oversight has not occurred.

In regards to T&R events, it quickly becomes apparent that the T&R events required of the 0430 MOS are convoluted in regards to performance and rank. It is difficult to defend the position that 0430 warrant officers, regardless of rank, are assigned identical performance events, conditions, standards, sustainment, and associated performance steps. It simply seems unreasonable to expect that a newly selected 0430 warrant officer would or could perform the same behaviors - with the same level of responsibility, accountability, knowledge, or experience - as a more senior 0430 chief warrant officer, or as in the case of five T&R events, the same as a 0430 LDO LtCol. As such, identifying the process used to rank-order 0430 mobility officers for promotion - when the T&R Manual fails to differentiate the performance standards of warrant officers to those of LtCols - seems unmanageable and incomprehensible.

In regards to post-secondary education, there are multiple concerns related to this analysis - even while the debate continues over the value and necessity of attaining collegiate-level degrees. One common belief is that post-secondary education serves as an avenue to enhance an individual's knowledge about the world concurrent with gaining practical knowledge in history, science, math, grammar, professional writing, logical thought, and reasoning that prove critical regardless of 'technical' proficiency. While many MOSs may excuse the lack of higher education as a product of deployments or rotation cycles, the volume of collegiate programs available online, aboard ship, or even in theater refute this defense especially when compared to similar peer groups of the same rank facing identical

obstacles. Therefore, it is remarkable that even though higher education is not a prerequisite for selection, nor a requirement for advancement, a single CSS MOS - the 0430 MOS - out of many appears either unwilling or incapable of even matching the average educational credentials attained by other CSS MOSs performing in the same environments and deployment cycles. Table 43 displays the highest educational level reported by five CSS-related MOSs that deploy and operate under similar conditions.

Table 43 Highest Education Level for CW03-5s of Comparable CSS MOSs

MOS	N	n = 6-year Degree	n = 4-year Degree	% of Selects with 4- or 6-year Degree
0430	72	1	2	4.17%
0170	181	17	30	25.97%
1390	21	0	4	19.05%
3010	24	2	3	20.83%
3510	67	2	3	7.46%

The perceived value of post-secondary education becomes clear as only 4.17 percent of 0430 CW03-5s reported attaining any 4-year and 6-year education compared to the 25.97 percent reported by the 0170 MOS, the 19.05 percent reported by the 1390 MOS, the 20.83 percent reported by the 3010 MOS, and the 7.46 percent reported by the 3510 MOS.

Not surprisingly, this trend continues in the 0430 LDO ranks. Compared to their LDO major peers, the 0430 LDO major attained lower percentages in all post-secondary educational areas while also being the MOS with the highest number of LDO majors selected (46 of 278) in the years 2005 through 2011. Table 44 demonstrates that 69.57 percent of the 0430 LDO Majors selected had only earned the minimum required high school diploma or equivalent, 13.1 percent higher than the 56.47

percent reported by all other MOSSs.⁶⁹ Additionally, compared to the 31.47 percent reported by all other MOSSs, only 23.91 percent of the 0430 LDO majors selected reported earning any education above four years.

Table 44 Highest Education Level Reported by LDO Majors and LtCols

Rank	High School Equivalent						4- and 6-year Degrees					
	0430		All MOSSs		0430		All MOSSs		0430		All MOSSs	
	N	N	n	%	n	%	n	%	n	%		
Major	46	232	32	69.57%	131	56.47%	11	23.91%	73	31.47%		
LtCol	15	71	8	53.33%	35	49.30%	5	33.33%	30	42.25%		

In regards to the 86 LDO LtCols selected for all MOSSs in the years 2005 through 2011, the 0430 MOS also had the highest number with 15 selections (17.44%)(the 6004 MOS reported the next highest with 10 selections). Here again, a higher percent of LDO LtCols selected into the 0430 MOS (53.33%) retained their initial high school equivalent educational level, compared to the 49.30 percent reported by all other MOSSs, as shown in Table 44. Finally, only a third of 0430 LDO LtCols (33.33%) reported earning a 4- or 6-year degree, compared to the 42.25 percent reported by all other MOSSs.

The lack of post-secondary education indicates a lack of personal initiative, especially when compared to other CSS peers and could become especially problematic in situations where the 0430 would be required to professionally interact and successfully communicate with peers; i.e., CW03-5s, majors, and LtCols from other MOSSs or other services. As such, the ability for the 0430 mobility officer to articulate "the strategic mobility requirements both present and future to appropriate agencies" seems highly unlikely when nearly

⁶⁹ 2-year associate degrees were not included in this table.

three-quarters (74.44%) report the same educational level (a high-school diploma) they had when selected, and only 14.29 percent report attaining a 4- or 6-year degree.⁷⁰

Even though post-secondary education is not a prerequisite for selection to WO or a requirement for promotion to CWO or LDO, the question remains as to why the 0430 MOS seems incapable or unwilling to attain post-secondary education - beyond the minimum 12th grade level - when other MOSs seems able and willing to do so (as shown in Table 44). In addition, the fact that the great majority of 0430 mobility officers possess only a high school diploma or equivalent - could explain much of the confusing guidance and apparent lack of oversight presented in the MOS Manual and T&R Manual, as well as explaining many of the formal training inconsistencies noted within this analysis.

Finally, if a warrant officer is considered the "technical specialist who performs duties that require extensive knowledge, training, and experience with systems or equipment which are beyond the duties of staff non-commissioned and unrestricted officers" (Pfister, 2000, p. 10), then the 0430 Mobility Officer MOS elicits a number of reasonable concerns. The first concern centers on the USMC guiding reference, the MOS Manual, which establishes subject matter expertise *in mobility* as the key MOS function, which requires "years of **training, education, and experience** to become proficient" (p. 1-21). Although the definition initially appears suitable and

⁷⁰ LDO LtCol and LDO Major computations are based on 2005 through 2011 selection board data; whereas, CWO3-5 selection board data was limited to the years 2006 through 2010, as 2005 and 2011 were unavailable for analysis.

appropriate for any MOS, they simply fail - based on the collected data findings - to apply to the 0430 Mobility Officer MOS.

Expertise in any occupational field is synonymous to deliberately increasing an individual's subject knowledge, technical proficiency, and procedural competency - which leads to greater responsibility and subsequently characterized by merit-based advancement. Consequently, the key elements to expertise must be knowledge of the subject and proficiency in subject-specific procedures. In regards to the 0430 MOS, the data was unable to substantiate "mobility subject matter expertise" considering nearly 30 percent of the 0430 warrant officer selected in 2010 came from non-logistics/embarkation fields like MAGTF planning and landing support. Also since 1990, there were at least 14 separate enlisted MOSs - each with widely dissimilar and diverse skill sets and experiences - selected to become 0430 mobility officers - hardly an endorsement for *mobility* expertise.

It was equally impossible to verify **years of training** as a valid requirement for selection to 0430 MOS as a full quarter of 0430 mobility officers (25.2%) failed to complete mandatory formal training. Nor could **years of education** be a valid requirement as 74.43 percent of 0430s chose to maintain the minimum 12th-grade education required for initial selection (or initial enlistment).

Labeling **years of experience** as a valid requirement proved extremely difficult as some warrant officers were selected with as little as three months TIG or barely eight years TIS. Furthermore, expertise does not appear to have developed over an extended number of

years as the data reflects that the average TIG of the twenty-two 0430s WOs selected in 2010 was one year and nine months.

As such, there is little resemblance between the data obtained in this analysis to the MOS Manual's description of the 0430 MOS. Specifically, formal training has fallen short or is incomplete, the 0430 T&R events are too generic and meaningless when spread across nearly every rank, the overwhelming majority of education attained across all ranks is limited to the 12th grade, and the TIG, TIS, and age requirements necessary for selection are far lower than other CSS MOSs performing similar functions in similar manners.

Consequently, there does not appear to be a requirement for "mobility subject matter expertise" as anyone from any MOS can become a "mobility expert" **after** they are selected for warrant officer. This raises the question that if anyone can successfully perform the duties inherent to the MOS to the level required for promotion to warrant officer with little to none subject-expertise, experience, training, or education - why then is this a primary MOS instead of a secondary MOS, a collateral duty, or even a staff billet?

0402 Logistics Officer

To gain a better understanding of the 0402 MOS requires a review of the U.S. Marine Corps unrestricted officer. As individual case data specific to the 0402 MOS was not available, collective accession data representative of all MOSs was utilized for this analysis.

U.S. Marine Corps Unrestricted Officer

U.S. Marine Corps officers have faced and conquered numerous challenges through leadership and sacrifice. Specifically, they have

used "their intellects to solve intractable problems" thereby, enriching the "Marine Corps' heritage" (Wilhelm, Gregson, Knutson, Van Riper, Krepinevich, & Murray (2006, p. 11). The implication is that Marine Corps officers possess superior intellects and as such are more capable of successfully resolving any challenge.

Intellect is best defined as the "faculty of thinking and acquiring knowledge".⁷¹ Consequently, intellect must be derived from the brain's higher-order cerebral cortex, which in itself is a product of individual experience and the knowledge an individual has learned. More to the point is that intellect involves "manipulating cognitive symbols, as opposed to simply retrieving previously learned knowledge" (Branch, 2009, p. 187). Intellect, like experience, is concerned with applying known rules, practices, and procedural steps (that have formed mental symbols) to solve problems and resolve issues. In a sense, our intellect ultimately serves as a "well-bred spinster lady" who is very different from the "sex-crazed monkey" that represents our basic instinctual functions of reproduction, survival, fight or flight, etc. (Dixon, 1994, p. 197).

Regardless, the cornerstone of intellect remains the application of knowledge; whereas, knowledge has always been linked with learning or being educated. As a result, a high level of education implies "knowing more" which - if applied appropriately - means greater intellect. Accordingly, U.S. Marine Corps doctrine directs that education "should provide an understanding of when to apply different techniques and procedures" and "when to use intuitive or analytical

⁷¹ Retrieved from Dictionary.com: <http://dictionary.reference.com/browse/intellect?s=t>

decision-making techniques" (MCDP-6, p. 131). As such, it is reasonable to equate higher levels of education to increased societal value and subsequently greater importance and salaries.

Therefore, if education is the foundation of intellect, successfully graduating from college demonstrates a high level of both education and purported intellect. Ergo, since unrestricted military officers are required to be college graduates they must be educated and by extension, must possess intellect. The institutionalization of this belief permeates throughout the U.S. Marine Corps, the Department of the Defense, and most importantly, our nation's civilian population. This is best illustrated by reviewing the University of California, San Diego (UCSD) career office's website that advises prospective graduates that the U.S. Marine Corps officer commissioning program "interviews and selects some of America's brightest college students and graduates to become Marine Corps Officers".⁷²

There are a number of serious implications that must be considered in accepting the assurance that four years of education and subsequent receipt of a college degree equate to greater intellect in military officers. Specifically, what are the realistic and valid implications of obtained a four-year degree in our current culture?

U.S. Marine Corps Commissioning

The U.S. Marine Corps officer commissioning process normally begins in college with acceptance into a Platoon Leaders Course (PLC). Besides meeting U.S. Marine Corps height and weight standards, and

⁷² UC San Diego Website from <https://ucsd-csm.symplicity.com/events/students.php?mode=profile&eid=ac8bf28fca708612e52027f2767240d6®id=04e5310fd6c2bb8a3b92b35c887d4fe3&pmode=overview&cf=fall2007>

attaining a 225 or better on the USMC Physical Fitness Test, a PLC applicant must also be a full-time student regularly enrolled at a regionally accredited college or university. In addition, the PLC applicant must have completed one academic term with a grade point average (GPA) "of at least a C (2.0 on a 4.0 scale)"⁷³ while a "failure to maintain a 'C' average for any regular academic term or semester" could lead to disenrollment.⁷⁴ Clarifying guidance⁷⁵ was later provided defining "testing accession standards for the purpose of application to Marine officer programs" as requiring a combined score of 1000 on the Scholastic Aptitude Test (SAT) (Math & Critical Reading).⁷⁶ Two elements of the minimum requirements raise concerns and therefore require additional clarification - the 2.0 GPA and the combined SAT score of 1000.

Grade Point Average (GPA)

A student's GPA is simply calculated by dividing the student's total earned course credits by the total amount of credit hours attempted to represent the percentile of course material mastered; e.g., a 2.5 GPA is equivalent to an 80 percent. The value of a high GPA varies depending on the graduate's desire to enter the workforce or to pursue graduate education and the resultant emphasis applied by the employer or admissions committee.

⁷³ MCO P1100.73B, Military Personnel Procurement Manual, Vol. 3, Officer Procurement dated 29 September 1989, pg. 2-25.

⁷⁴ NAVMC 10418-2, Certificate of Understanding, Reasons for Disenrollment form, dated March 1990.

⁷⁵ MARADMIN 064/11, Amplification to testing accession standards for the purpose of application to marine officer commissioning programs, dated 26 Jan 2011.

⁷⁶ Applicants also have the option of scoring a 74 Armed Forces Qualification Test (AFQT) on the Armed Service Vocational Aptitude Battery (ASVAB) or a 22 composite score on the American College Test (ACT).

David Koepple, a writer for the New York Times, interviewed multiple human resource professionals and learned that many feel that a graduate's GPA "is the best single predictor of job performance in the first few years of employment" that serves as the "best indicator an individual is likely to succeed" because it "demonstrates a strong work ethic and smarts" (p. 1). Additionally, Koepple's article recommends that graduates should never put a GPA on a resume that is below a 3.0 because "That is like saying 'Hi, I'm mediocre'."⁷⁷

This advice is reinforced by Matt Berndt, creator of the TheCampusCareerCoach.com website, who offers some very pragmatically honest advice concerning GPAs. Berndt advises that, "In some fields, particularly technical fields, GPA is a clear indicator of subject mastery, so a high GPA is really important. Think about it - do you want to go to a doctor that graduated with 2.2 GPA? How confident will you be in that doctor's ability? When skills are easily quantified and measured, GPA is generally a good indicator of potential performance".⁷⁸

A recent Naval Postgraduate School study by Sandstrom (2011) on officer recruiting describes officer accessions that shipped to Officer Candidate School (OCS) in October 2006 through September 2010. Sandstrom's (2011) findings reports that the 23,667 officer accessions self-reported a final college GPA of 2.8858 (N = 23,667, SD = .7739) on 4.5 scale. Converting the GPA from a 4.5 to 4.0 scale reveals an even lower GPA of 2.565 [$4.0(2.8858/4.5) = 2.565$]. While a 2.565 GPA may be .565 of a point higher than the minimum GPA of 2.0 required for

⁷⁷ <http://www.nytimes.com/2006/12/31/jobs/31gpa.html?pagewanted=all&r=0>

⁷⁸ <http://thecampuscareercoach.com/2012/11/27/can-i-get-a-job-with-a-2-2-gpa/>

U.S. Marine Corps officer commissioning, it is .585 of a point lower than the current undergraduate national average GPA of 3.15 (Rojstaczer & Healy, 2010), where the average GPA for private colleges is 3.3, and the average GPA for public institutions is 3.1.

What makes this particularly disturbing is the national trend of grade inflation rampant in colleges and universities today. Rojstaczer and Healy (2012) report the combined findings of over 1.5 million undergraduate students from over 135 four-year colleges and universities that indicate 43 percent of all letter grades are A's (up 28 percentage points since 1960, and 12 percentage points since 1988) while D's and F's typically account for less than 10 percent of all letter grades.

To emphasize the point, consider what would be required to obtain a 2.56 GPA. Normally 120-semester hours are required for an undergraduate degree, with most courses being taught as three-semester hours, each. Therefore, if a student received no failing grades (F's), and 43 percent of their grades were A's, then the student received a 4.0 GPA in 17 courses. If this were the case, at best the student could not have received a B in any course, and had to receive a C in 11 courses (27 percent with a 2.0 GPA). For the remaining 12 courses, the student could not received any grade higher than a D (30.0 percent with a 1.0 GPA) to have earned a 2.56 GPA [$2.56 = 100 / (43 \times 4.0 + 27 \times 2.0 + 30 \times 1.0)$]. Unfortunately, this means the graduate barely passed (receiving a D) nearly a third of the courses (30%) required to earn an undergraduate degree. What is even more discouraging is the number of courses a student would need to get a D

in to earn a 2.0 GPA - the minimum GPA required for U.S. Marine Corps commissioning programs.

Scholastic Aptitude Test (SAT)

The second concern was related to the minimum combined Scholastic Aptitude Test (SAT) score of 1000 required for acceptance into U.S. Marine Corps commissioning programs. As background, the SAT consists of three parts: critical reading (CR), mathematics (M), and writing (W). The scores from each section can range from 200 to 800, with the best possible total score being a 2400.⁷⁹ For the 1.647 million college-bound seniors that took the test in 2010-2011, the average combined SAT score was a 1011 (497 CR and a 514 M).⁸⁰ Although, put in another way, of the 1,376,745 individuals who took the SAT in 2006, 4,476 students scored a 1000 combined SAT score. This means that they only scored better than 4.1 percent, and consequently scored below 95.9 percent of all test takers.⁸¹

Fortunately, individual colleges and universities have different SAT admission requirements. For example, the University of California, San Diego (mentioned previously)⁸² admitted 22,965 freshmen students in 2012 with a combined SAT score of 1329 (639 CR & 690 M); whereas, the 4,225 undergraduate students that enrolled in North Carolina State University in 2012 had an average combined SAT score of 1218 (591 CR & 627 M).⁸³ Additionally, specific scholarship programs like the U.S. Navy Reserve Officer Training Corps (NROTC) require

⁷⁹ Retrieved from <http://www.princetonreview.com/college/good-sat-score-act-score.aspx>

⁸⁰ Retrieved from http://nces.ed.gov/programs/digest/d11/tables/dt11_156.asp

⁸¹ 2006 SAT scores, retrieved from http://www.satscores.us/sat_scores_by_score.asp?score=1000

⁸² Retrieved from http://admissions.ucsd.edu/_files/counselorlink.pdf

⁸³ Retrieved from http://www2.acs.ncsu.edu/upa/admissions/freshman_profile.htm

their applicants to have an average combined SAT score of 1050 (530 CR & 520 M).⁸⁴

Applying the officer accession data obtained by Sandstrom (2011) to the Marine Corps Recruiting Command (MCRC) conversion chart located in the Military Manpower Procurement Manual (MPPM)⁸⁵ reveals an average combined SAT score of 1129 [5.4572 (N = 13,120, SD = 1.6689)] for this targeted sample. By cross-referencing the average combined SAT score of 1129 to the minimum SAT requirements of the top 224 colleges and universities⁸⁶ (identified in Appendix P) the number of institutions with minimum SAT requirements less than 1129 could be determined. Unfortunately, the 13,120 sampled Marine officer accessions would have only met the minimum SAT requirements for the bottom 49 (21.89%) of the top 224 colleges and universities in the nation.

Most would agree that a high GPA indicates mastering a higher percent of the course learning objectives and thereby implies the graduate's greater value and potential - either to the hiring authority, or to graduate program admissions. Additionally, the SAT is used as an indication of how a student will perform within an academic setting - where higher scores imply greater potential and performance. Therefore, based on this analysis, a few final concerns must be presented. First, if hiring agencies consider a 3.0 GPA to be mediocre, what then does the 2.0 GPA required for U.S. Marine Corps officer selection programs imply? Second, what does it say about the

⁸⁴ Retrieved from <http://collegeapps.about.com/od/collegeprofiles/p/NC-State.htm>

⁸⁵ (see Footnote 63)

⁸⁶ Minimum SAT requirement for Brigham Young (UT) were not reported.

quality of U.S. Marine Corps officer applicants when the required minimum SAT score is only better than 4.1 percent of all test-takers.

0402 Logistics Officer MOS

While the requisite GPA and SAT scores necessary of consideration to the unrestricted officer ranks are intriguing - and disconcerting - this analysis is more concerned with the 0402 Logistics Officer MOS, which begins with an examination of raw data obtained from The Basic School (TBS). Upon request, nearly six years of raw data was received from TBS for graduates attending academic years 2007 through 2012, which included 39 classes, for a total sample of 10,143 valid cases.⁸⁷ Extensive analysis was conducted concerning assignment of MOSs, MOS preferences, class ranking, commissioning source, college attended, degree type and major field of study, gender, and traditional or non-traditional college experience.

The findings show that out of 31 potential MOS assignments, the three MOSs that received the most graduates, and accounting for nearly half of all graduates (48.97%) were the 7599 Flight Officer MOS (n = 2,294), the 0302 Infantry Officer MOS (n = 1,619), and the 0402 Logistics Officer (n = 1,054). The following findings pertain exclusively to the 0402 logistics officer unless indicated for comparison purposes.

In regards to MOS assignment and MOS preference, 31.21 percent of graduates assigned the 0402 MOS received the MOS even though it was not one of their top three preferences - which was nearly twice the

⁸⁷ Unpublished manuscript Lathers, J.D. (2013) titled "Critical Analysis of U.S. Marine Corps The Basic School (TBS) Graduates, 2007 through 2012".

number (18.78%) reported for graduates assigned to all other MOSs, and over five times as many (5.99%) reported by the 0302 MOS. Conversely, less than a third of graduates assigned to the 0402 MOS requested that MOS as their first preference (29.22%), compared to nearly three quarters (70.11%) of graduates assigned to the 0302 MOS, and every graduate assigned to the 7599 MOS.

Class ranking was used to determine 'quality' graduates where higher class rankings implies better placement due to superior performance in comparison to other TBS students. In regards to the 0402 logistics officer, the average graduate assigned to the 0402 MOS was ranking 143rd (within a range of 1st through 289th) - which was 31 points lower than the average class ranking of 112th received by graduates assigned to the 0302 MOS. Additionally, out of 1,054 graduates assigned to the 0402 MOS, only a single graduate was ranked first in class (out of 39 classes), less than one percent (.09%) of the entire MOS.

Concerning class ranking and quality graduates, the findings also indicate that while the 0402 MOS received the third highest number of graduates (n = 1,054) there were fewer graduates from the top five percent (n = 19) and upper third (n = 317) than from the bottom five percent (n = 71) and lower third (n = 409). To put this into context, in a normal distribution, approximately five percent of the graduates assigned to any MOSs should come from the upper and lower five percents; whereas, the upper and lower thirds should hold roughly 33.33 percent, each. The findings indicate that this is not the case for the 0402 MOS.

A normal distribution for the 0402 MOS (n = 1,054) should result in approximately 53 graduates each being ranked in the top and bottom five percents, and roughly 348 graduates each ranked in the upper and lower thirds. Instead, there were only 19 graduates (1.8%) who ranked in the top five percent (3.2 percent fewer graduates than the anticipated five percent) compared to 71 graduates (6.74%) ranked in the very bottom five percent (1.74 percent more than the normal distribution of five percent) assigned to the 0402 MOS. Additionally, the 0402 received 317 graduates from the upper third (35 graduates (3.25%) fewer than anticipated) and 409 graduates from the lower third (57 more graduates (5.47%) than what would normally be expected).

To ensure this trend was not universal to other TBS graduates, the 0302 infantry officer was examined. The 0302 infantry officer displayed contradictory results to those noted in the 0402 logistics officer; i.e., that more graduates came from the top five percent (10.87%) and upper third (42.19%) than from the bottom five percent (25.69%) and lower third (2.96%). Figure 15 demonstrates the contradictory assignment of quality TBS graduates (as determined by class rankings) to the 0402 and 0302 MOSs.

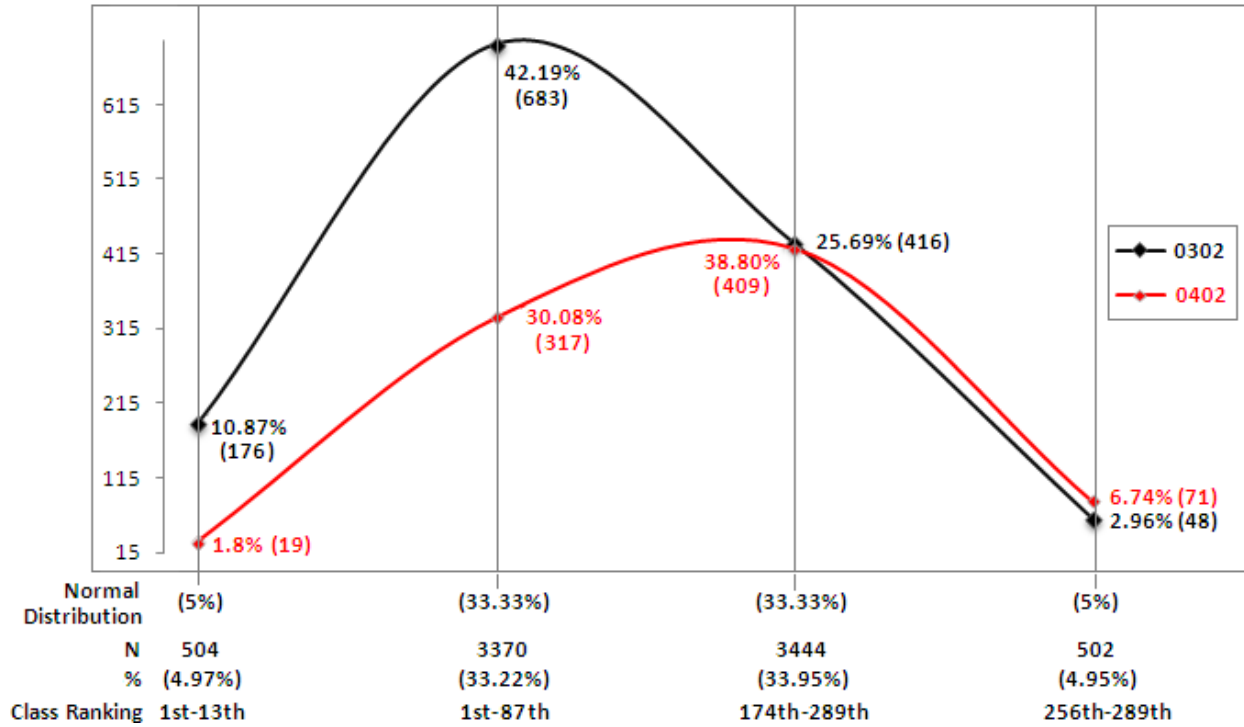

Figure 16 0402 and 0302 MOSs TBS Graduate Class Rankings

In the majority of MOSs, particularly highly technical and aviation fields, officers are progressively groomed within their subject areas for higher levels of responsibility. For example, a 1302 engineer officer starts their career with the Combat Engineer Officer Course, and then completes the Weapons and Tactics Instructor Course, the Joint Engineer Operations Course, and the Urban Breacher/Dynamic Course. In conjunction with gaining on-hand experience by serving in the engineering field, the sequential combination of progressively advanced courses builds a solid foundation that becomes so ingrained that it serves as a point of reference for any future endeavor. Thereafter, when the 1302 engineer officer is later assigned to a staff billet overseeing multiple sections, personnel and systems, they can confidently apply their

foundational template of known functioning processes to proficiently perform any task.

The 0402 Logistics Officer MOS combines many of the duties once assigned to MOSs with long histories of meritorious operational service - like motor transport; although, other duties mimic MOSs that are currently performing the same functions - like engineering. As such, upon detailed comparison of other legacy MOSs, it seems unrealistic that a single individual - especially someone with no organizational experience and having attended only a single entry-level course - could be capable of initially comprehending all aspects of the six tactical functions of logistics. Specifically, the 0402 logistics officer must successfully execute multiple, diverse skill-sets, to include: all aspects of supply, determination of requirements, procurement, storage, distribution, disposal & salvage, maintenance, inspection, classification & service, adjustment & tuning, testing & calibration, repair & modification, rebuilding & overhaul, reclamation, recovery & evacuation, transportation, embark, landing support, port & terminal operations, motor transport, air delivery, freight & passenger transport, materials handling equipment, general engineering, engineer reconnaissance, horizontal & vertical construction, facilities, maintenance, demolition and obstacle removal, explosive ordnance disposal, bridging, health services, health maintenance, casualty collection, casualty treatment, temporary casualty holding & casualty evacuation, services, personnel administration, religious ministries, financial management, communications, billeting, messing, band, morale-welfare-recreation,

disbursing, postal services, exchange, security support, legal services support, civil affairs support, and graves registration.

To amplify the point a list of MOSs known to perform the specified tasks identified as functions and sub-functions of tactical logistics (MCWP 4-11, pg. 1-4) was constructed as Table 45. Known MOS-generating and associated collateral training, as reported in the TIP training tracks, has been aligned to each of the functions and sub-functions.⁸⁸

Table 45 MOSs Performing the Six Functions of Tactical Logistics and Associated Training

Functional Area	MOS	MOS-Generating School (CID)	Length
Supply			
Determination of Requirements	3002	Ground Supply Officer (M03C0G1)	85
Procurement	3006	Contingency Contracting Officer (M03EB11)	123
Storage	3051	Enlisted Warehousing Basic (M03SCM1)	19
Distribution	3112	Distribution Management Specialist (M03TNA1)	33
Disposal & Salvage	NA	Def Hazardous Materials/Waste Handling (A14TNLM)	5
Maintenance			
Inspection & Classification / Service, Adjustment & Tuning	3521	Automotive Organizational Maintenance (M0335H7)	71
Testing & Calibration	2871	Calibration Technician Course (USMC) (M3028T1)	182
Repair & Modification	3521	Automotive Maintenance Technician's Career (AMTCC) (M033447)	90
Rebuilding & Overhaul	3524	Fuel And Electrical Systems Component Repair (M03ACP7)	62
Reclamation, Recovery & Evacuation	3536	Vehicle Recovery (USMC) (A16CAJ1)	40
Transportation			
Embark	0430	Mobility Officer Course (M03H347)	24
Landing Support	0481	Basic Landing Support Specialist (BLSS) (M0313I7)	39
Port & Terminal Operations	0430	Amphibious Ship Load Planner's (M030DI7)	24
Motor Transport	3510	Motor Transport Maintenance Officer Course (M03MBJ7)	35
Air Delivery	0451	Multi-Mission Parachute System (MMPS) (USMC) (A14GAC4)	13
Freight & Passenger Transport	3537	Motor Transport Operator (USMC) (A1635X1)	32
	3102	Basic Freight Traffic (A14TNP7)	14
	3102	Passenger Travel Specialist (A14TNC7)	14
Materials Handling Equipment	3051	Enlisted Warehousing Basic (M03SCM1)	19
General Engineering			

⁸⁸ Although multiple MOSs often perform the same task, only a single MOS was assigned to each sub-function to reduce overall table size.

Engineer Reconnaissance	NA	Reconnaissance & Surveillance Leaders (A03H4H1)	35
Horizontal & Vertical Construction	1302	Combat Engineer Officer (M03ACC2)	108
Facilities Maintenance	1120	Utilities Officer Course (M03ACE2)	21
Demolition & Obstacle Removal	NA	Urban Breacher's Course (M03KA92)	21
Explosive Ordnance Disposal	2336	DOD Joint Explosive Ordnance Disposal Basic (N56GPX1)	200
Bridging	NA	Engineer Officer Captains Career (A16RGE1)	148
Health Services			
Health Maintenance	NA	Field Medical Services Officer Course (M03M6F3)	12
Casualty Collection	NA	Field Medical Service Technician (M03M6D3)	49
Casualty Treatment/Evacuation & Temporary Casualty Holding	0302	Infantry Officer Course (M02RGU4)	86
Services			
Personnel Administration	0170	Personnel Officer (M030118)	19
Religious Ministries	NA	Chaplain/RP Expeditionary Skills Training (M03L753)	49
Financial Management	3404	Financial Management Officer (FMOC) (M03FNH0)	91
Communications	0602	Basic Communications Officer (M02LC52)	147
Billeting	NA	Lodging Supervision Course, Army FMWR Academy	5
Messing	3302	Senior Food Service (USMC) (A14FAD1)	26
Band	5524	Music Basic Course (N0355A2)	151
Morale-Welfare-Recreation	NA	Programming & Special Events Course, Army FMWR	14
Disbursing	3410	Financial Warrant Officer (FWOC) (M03FNK0)	91
Postal Services	0160	Postal Supervisor Course (A35A8Q1)	18
Exchange	4133	Strategic Retail Management Course	5
Security Support	8152	Basic Security Guard (M18M4V1)	42
Legal Services Support	4402	Basic Lawyer (N0501P1)	105
Civil Affairs Support	0530	Civil Affairs Officer (M020A3D)	26
Graves Registration	0471	Mortuary Affairs Specialist (A14M2B1)	29

Albeit not definitive, there appears to be at least 33 MOSs (officer, enlisted, entry, and advanced) that perform the six functional areas of tactical logistics as subject matter experts within their occupational specialties. Therefore, for a single individual to become even rudimentarily competent in all six functional areas would require successful completion of 44 formal courses spanning 2,422 days. This equates to roughly six years, seven months and 21 days of exclusive occupationally specific training.

Herein lies the chief concern identified in this analysis concerning the 0402 Logistics Officer MOS. In contrast to highly technical fields, the 0402 logistics officer appears to rely on the theoretical concept that a generalist can successfully oversee

multiple diverse fields, as is the case when a colonel is promoted to general. Traditionally, generals no longer represent a specific field, rather they "are expected to coordinate and control multiple branches, such as artillery, cavalry, and engineers – that is, to become generalists" (Ricks, 2012). In addition, the average TIS, TIG, and age of selection to brigadier general in the Marine Corps are 26.15 years, 4.35 years, and 47.95 years, respectively.⁸⁹ On the other hand, the 0402 logistics officer is expected to perform similar duties of command and control over multiple diverse MOSs with less than one year TIS, less than six months TIG, and an average age of 23.33 years (Sandstrom, 2011). Where the brigadier general has decades of experience to apply to overseeing separate and distinct fields, the 0402 logistics officer is expected to do the same with only TBS and a single 56-day, MOS-generating formal course.

The findings of this analysis indicate that with so little formal training, the logical conclusion concerning the 0402 MOS is that initial success is greatly dependent on the permanence of the organization to which they are assigned. Essentially, the LOC graduate only fills those billets that are already institutionally ingrained and formerly established by policy and procedures, which also serve to limit the majority of opportunities to commit seriously monumental mistakes. Of course, the competency of their SNCOs and the mentorship provided during senior 'counseling' sessions also contribute significantly to the 0402 logistics officer's initial success.

⁸⁹ FY 2013 USMC Brigadier General promotion selection data retrieved 15 January 2013 from <https://www.manpower.usmc.mil>.

What makes this role of subordinates and seniors so relevant is the ratio of 0402 logistics officers to 04XX enlisted personnel strengths. As reflected in Table 46, the 03XX infantry field has the highest number of commissioned officers with 3,641, while the 04XX logistics occupational field has the second largest number with 2,470. Table 46 Officer to Enlisted MOS Strength

MOS	N	Officer			Enlisted	
		MOS	n	% of N	MOS	n
03XX	60607	03XX	3641	6.01%	03XX	56862
06XX	25119	04XX	2470	26.13%	35XX	24502
35XX	24628	06XX	1698	6.76%	06XX	23269
13XX	16681	08XX	1451	15.53%	13XX	15548
01XX	12542	13XX	1002	6.01%	30XX	11313
30XX	12328	01XX	980	7.81%	01XX	11246
04XX	9454	30XX	971	7.88%	61XX	8996
08XX	9346	60XX	550	7.19%	08XX	7855
61XX	8996	58XX	384	5.19%	28XX	7067
60XX	7649	28XX	47	0.65%	58XX	6971
58XX	7394	21XX	35	0.49%	60XX	6944
28XX	7184	35XX	0	0.00%	21XX	6928
21XX	7082	61XX	0	0.00%	04XX	6798

What makes this problematic is that while the 03XX occupational field has the most commissioned officers, they also have the most enlisted Marines - equating to one commissioned officer to 15.62 enlisted Marines. On the other hand, the 04XX occupational field reports 2,470 officers to 6,798 enlisted, equaling one commissioned officer to 2.72 enlisted Marines. Furthermore, this equates to 26.13 percent the 04XX logistics occupational field being comprised of commissioned officers; compared to only 6.01 percent of the 03XX infantry occupational field.

Another factor concerning the 0402 logistics officer is the frequent billet rotations. As discussed previously, after a few years

performing a set of known tasks and functions, the 0402 is reassigned into another logistics-related field they vaguely remember from their entry-level training - but at least now know how to utilize resources, emulate expertise, and most likely organize and delegate - relying on their rank/billet to ensure compliance and professional respect. The 0402 MOS billet-rotation cycle continues until they are sufficiently promoted into positions where their lack of technical competency, and individually driven leadership skills, are fully insulated from the specific occupational specialties they are directed to oversee and supervise.

While this analysis was not conducted to subjectively criticize or to assign blame, some conclusions are too blatantly obvious to be ignored. Specifically, while the lack of subject expertise appears innocuous, history has already proven otherwise. The first example that demonstrates the cost of losing subject matter expertise occurred during the early stages of Desert Shield.

By the end of 1990, 0402 logistics officers had subsumed all functions, formally assigned to other officers in legacy MOSs including the arrival and staging of equipment and supplies via the process called time-phased force deployment document (TPFDD). During the early stages of Desert Shield "some 17,450 tracked and wheeled vehicles, 450 aircraft and 1,521 sea land containers had been discharged at air and sea ports" (Lexington Institute, 2005, p. 1) even though logistics organizations were ill-formed, inexperienced, and unprepared to process and distribute items throughout the theatre.

Daniels (2008) describes the creation of 'Iron Mountains' of unnecessary supplies shipped from CONUS to the Middle East and back again while the loss of container documentation and logistics intelligence required additional personnel and resulted in lengthened delays. All of the associated problems and heightened costs centered on the "inability of the logisticians to move vital supplies, particularly an adequate number of spare parts, forward to the combat units" (Lexington Institute, 2005, p. 1).

The generalized tactical logistician simply did not have the "necessary ability to know what was needed, where, or how to get it there. There were backlogs of hundreds of shipping containers at distribution because of identification and transportation problems" (Lexington Institute, 2005, p. 1). Individual units were forced to wait to receive their supplies as many "containers languished in the staging area while awaiting identification to determine the appropriate receiving unit" (Myers, 2004). Also, in after action reports, the 3rd Infantry Division reported "many units operated dangerously low on ammunition, fuel, water and other sustainment items" (Lexington Institute, 2005, p. 1).

After Desert Storm, the associated costs of shipping, storing, maintaining, tracking, manifesting, validating, and subsequently returning the massed piles of incorrectly ordered and unused supplies and equipment warranted investigation by the General Accounting Office (GAO) and took "logisticians over a year to sort through the chaos and identify the contents of the containers stacked at the ports" (Daniels, 2008, p. 1). The Government Accounting Office (GAO)

utilized the notional unit costs to maintain the then-existing U.S. Marine Corps forces to be about \$6 billion, not including the estimated operations and maintenance (O&M) budget of \$1.9 billion (Bowsher, 1991, p. 3-6).

A second example of the troubling effect of lacking subject matter expertise was brought to my attention by university colleagues who made the observation while reviewing the last decade of newspaper headlines. It became apparent to non-military professionals that the majority of negative press concerning U.S. Marines coincided with the generalized duties and responsibilities of the 0402 logistics officer's area of influence and subsequent accountability. The reviews suggested that nearly every negative event - convoy operations in unique environments including Improvised Explosive Devices, command and control and extended supply lines, vehicle recommendations and contract acquisitions (especially concerning armored vehicles), etc. - were related to motor transport operation and vehicles. The specialized skill-sets were once under the cognizance of the 3502 Motor Transport Officer MOS; although, like many other duties, to include determining requirements, services, embarkation, port authority, and the aforementioned iron mountains (that were once associated with supply and distributed operations), were now specifically the responsibility of the 0402 Logistics Officer MOS. Therefore, the tactical logistician's lack of subject matter expertise clearly resulted in an inability to "supply deployed forces with adequate amounts of body armor, armored Humvees, tank treads, and ammunition (Lexington Institute, 2005).

Not surprisingly, even with the loss of life and equipment due to improperly equipped vehicles and outdated tactical doctrine, and the associated billions of dollars unnecessarily appropriated building the 'iron mountains' there was little impact on individual promotion or careerism. Ricks (2012) explains this phenomenon as a product of unit one-year rotations where "officers came and went without seeing the consequences of their actions, enabling almost all to claim that they presided over progress" (p. 1). For comparison, consider accountability during World War II where the firing of a senior officer was a sign that the military system was effectively working as designed, the belief today is that an officer's relief is seen as a "sign that the system has somehow failed" (Ricks, 2012, p. 1).

To reemphasize the point, the analysis was not conducted to criticize a specific MOS, but unfortunately, the findings simply fail to present any accolades in regard to the 0402 Logistics Officer MOS. Although these conclusions are not altogether surprising as a faulty foundation undermines any construction - be it a building or a MOS. Consider the findings, beginning with the unrestricted officer selection process.

First, the minimum SAT requirements required for acceptance into a U.S. Marine Corps officer program is set below the average SAT score obtained by test takers in 2013; whereas, acceptance into a unrestricted officer program equates to scoring better than only 4.1 percent of test takers in 2006. The OCS candidates' self-reported SAT scores and GPAs demonstrate unrestricted officers are considered less

than average and below mediocre - even with the unbridled grade inflation reported in U.S. colleges and universities.

Second, regardless of scores and grades, U.S. Marine Corps unrestricted officers are ranked against their peers in TBS. In regards to the 0402 Logistics Officer MOS, considerably more graduates from the lowest class rankings are assigned to the MOS than from the higher class rankings. Additionally, more graduates who did not prefer the MOS received it than graduates who received the MOS as a preference.

While the 0402 logistics officer's ownership of the roles and responsibilities essential to motor transport operations and maintenance, embarkation, port authority, services, etc., is incontrovertible there appears to be little if any accountability. Rather, the 0402 logistics officer appears to be quite successful as a generic officer (who is incidentally responsible for logistics) as the average percentage of 0402 captains, majors, and LtCols selected for promotion, in the years 2005 through 2013, is higher than the average selection rate shown by all other MOSs.

As an occupational field, the 0402 MOS appears to have chosen to ignore doctrinal guidance clarifying "training is the key to combat effectiveness" (MCDP 4, pg. 108). The findings indicate that the 0402 MOS seems to be acutely deficient in providing occupation-specific guidance (as 0402 MOS T&R events are nearly identical to 0491 MOS T&R events) as well as creating training opportunities (only a single entry-level course is required for advancement or sustainment).

Finally, as it seems highly improbable that any entry-level officer could attain the training required to master the varied specialties of the six functions of tactical logistics, the result would more likely be an untrained, unseasoned, approximately competent performer who survives only as a result of subordinate skill-sets, peer collaboration, and senior guidance and mentorship. As such, if the organization's goal was to create a generic officer - to be taught the required skills once there are assigned a billet - it may have only succeeded in producing an insubstantial performer who gains subject familiarization - not expertise - in a non-standardized, eclectic manner unlike the majority of their peers.

While many may consider the 0402 logistics officer a success (in light of their billet assignments, high selection rate, and progressive promotions), it can be readily inferred that individual accomplishment is derived more from what the 0402 can manipulate or prevent and not from any MOS-specific, doctrinal driven, step-by-step process or procedure deemed critically essential for mastering a highly specialized MOS; e.g., like the 0802 field artillery officer or 5902 electronics maintenance officer.

Currently, the 0402 logistics officer fills the role of any one of many generic staff officer billets, performing non-specialized tasks that anyone could perform, and once assigned subsequently groomed by superiors as they see fit. This is remarkably similar to the way logistics officers used to be employed when staff billets were considered additional or secondary MOSs and were filled by any qualified officer. The only difference was then an officer had to

have first demonstrated expertise (and success) in a specific occupational specialty before assignment compared to the current 0402 logistics officer who begins with no expertise, one formal course and the luck of the draw on assignments and mentorship.

Regardless of the motive, there has been tremendous effort and expenditure of resources in creating the generalist 0402 Logistics Officer MOS as a byproduct of eviscerating expertise-driven, subject-specific, legacy MOSs like motor transport. Unfortunately, generalization without a solid foundation becomes personality without process - dependant on non-standard methods, lockstep dictatorial management, selectively ignored policy, or happenstance.

As such, while the effort taken to create the generalist should be recognized, the recognition should serve as an example of what not to do. Effort without success is simply wasted effort and is analogous to digging the finest fighting hole - exactly 6.5' by 3', reinforced sandbag berm, multiple grenade sumps, Constantine wire, established fields of fire, slash-wire communication, etc. - in the wrong location. If the results are failure (as the enemy flanks the perfect fighting hole's position) then no one cares how much effort was expended - only that the action ended in failure.

All in all, this analysis' findings indicate that the 0402 logistics officer begins as a mediocre college graduate, who then fails to excel as a TBS candidate, only to receive a MOS they did not request, to subsequently attend a single required formal course, *that for the last 12 years has graduated 99.95 percent of all attendees with a 94.76 class average*, to receive incomplete and eclectic formal

familiarization to a level barely sufficient to perform in a nonspecific billet utilizing vague and varying formal performance guidance, before being reassigned into another unknown assignment - all while being promoted ahead of their peers.

Final Thoughts and Conclusions

The findings, collected from the varied data sources - MOS Manuals, T&R performance events, formal school resource requirements and student completion records, and promotion guidance and selection results - reveal that the 04XX logistics occupational field is a collection of generic and ambiguous roles, performing vague non-subject specific tasks that many other occupational fields redundantly perform, to meet indistinguishable standards that fail to differentiate between rank, responsibility, or years of service. Specifically, maintenance management is utilized by every maintenance and supply field to requisition component repair; therefore, there is no need for an exclusive 0411 MOS. Embarkation and landing support are synonymous to supply operations, transportation, and warehousing - less helicopter support and port authority functions; therefore, in lieu of the narrow, restrictive, and stove piped 0431 and 0481 MOSs their duties could readily be incorporated into other vocations with little subject-material deviation. By simply performing the identical functions performed by every other senior staff noncommissioned officer, the 0491 logistics chief is unique only in their generality and lack of subject expertise; as such, the MOS is not critical for operational success. Finally, both the mobility officer and logistics officer appear to learn their vocations *after* being selected or

assigned; furthermore, as they lack any foundational MOS expertise, their career advancement and MOS credibility is dependant not on unvarying process-driven methodology but instead on the non-standard mentorship provided by their immediate supervisors, peers, subordinates, and established organizational policy. Consequently, both the 0430 and 0402 MOSs should be combined with supply, distribution, or motor transport (which requires re-establishing the 3502 Motor Transport Officer) MOSs or converted to staff billets *after* the Marine has gained sufficient experience and expertise in any field.

The final conclusion - from a purely process-orientated, resource manager's viewpoint - is that the duties and associated responsibilities currently performed and held by the 04XX logistics occupational field could readily become staff officer or secondary MOS billets capable of being performed by any Marine from any MOS; thereby, resulting in tremendous resource savings and a more efficient, effective organization.

References

- Bowsher, C. A. (1991). *Cost and financing of operation desert shield*. United States General Accounting Office testimony (GAO/T-NSIAD-91-03). United States House of Representatives.
- Branch, R. M. (2009). *Instructional design: The ADDIE approach*. Springer: New York, NY.
- Daniels, K. F. (2008). The distribution dilemma: That last tactical mile. *Army Logistician*, volume 40(5), 1. Retrieved from http://www.almc.army.mil/alog/issues/SepOct08/tacticalmile_spectrum.html.
- Dixon, N. (1994). *On the psychology of military incompetence*. Pimlico/Random House: London, England.
- Jensen, E. (2008). *Brain-based learning: The new paradigm of teaching*. (2nd ed.). Thousand Oaks, CA: Corwin Press.
- Lexington Institute (2005). *Implementing Logistics Transformation*. Retrieved from <http://lexington.server278.com/docs/665.pdf>
- Myers, L. K. (July-August 2004). Eliminating the iron mountain. *Army Logistician, Profession Bulletin of U.S. Army Logisticians*. Retrieved from http://www.almc.army.mil/alog/issues/JulAug04/C_iron.html.
- Perry, T. A. (2006). An analysis of primary military occupational specialties on retention and promotion of mid-grade officers in the U.S. Marine Corps (Master's thesis). Naval Postgraduate School: Monterey, CA.

- Pfister, M. R. (September 25, 2000). USMC restricted officer program, briefing for the Congressional Budget Office. In D. L. Crippen (2002), *The warrant officer ranks: Adding flexibility to military personnel management* (p. 9). Congressional Budget Office: The Congress of the United States
- Ricks, T. E. (2012, November). General Failure. *The Atlantic Monthly*. Retrieved from <http://www.theatlantic.com/magazine/archive/2012/11/general-failure/309148/>
- Rojstaczer, S., & Healy, C. (2010). Grading in American colleges and universities. *Teachers College Record*. Retrieved from <http://www.tcrecord.org/PrintContent.asp?ContentID=15928>.
- Rojstaczer, S., & Healy, C. (2012). Where A is ordinary: The evolution of American college and university grading, 1940–2009. *Teachers College Record*, 114(7), 1–23. Retrieved from <http://www.tcrecord.org/Content.asp?ContentId=16473>.
- Sandstrom, M. R. (2011). *Analysis of minority officer recruiting in the U.S. Marine Corps* (Master's thesis). Naval Postgraduate School: Monterey, CA.
- Wilhelm, C. E., Gregson, W. C., Knutson, Jr. B. B., Van Riper, P. K., Krepinevich, A. F., & Murray, W. (2006). *U.S. Marine Corps officer professional military education 2006 study and findings*. Marine Corps University: Quantico, VA.

APPENDIX A - 0411 MOS DESCRIPTION

MOS 0411, Maintenance Management Specialist (MGySgt to Pvt) PMOS

a. Summary. The maintenance management specialist provides advice, guidance, and assistance to the unit's equipment commodity/section managers and maintenance personnel to ensure a systematic approach to maintenance operations of ground equipment. The maintenance management specialist supervises maintenance management and maintenance personnel in monitoring and reporting of maintenance management policy, programs, procedures and maintenance automated information system (MAIS) requirements and analyzes, maintenance management functional elements/areas, maintenance production functions, and maintenance engineering actions in support of equipment total lifecycle systems management (TLCSM) efforts. When serving in the capacity of the maintenance management officer, coordinates the commander's interest, resources, production, and information requirements in operational planning to ensure effective management of personnel, equipment, maintenance, and materiel to meet operational objectives.

b. Prerequisites

- (1) Must be a U.S. Citizen.
- (2) Must possess a GT score of 100 or higher.
- (3) Security requirement: Secret security clearance eligibility.

c. Requirements

- (1) For PMOS assignment, complete the Basic Maintenance Management Specialist Course (BMMSC), Logistics Operations School, Marine Corps Combat Service Support Schools, Camp Johnson, NC upon entry or lateral move at the rank of Sergeant or below. Marines who make a lateral move must complete the applicable Marine Corps Institute (MCI) 0410, MIMMS prior to reporting to formal schools.
- (2) As provided in paragraph 0005.2, Certification of the MOS as an additional MOS (AMOS) may be awarded by commanders after demonstrating the appropriate Training and Readiness Manual standards (see paragraph d. below), and completion of a minimum six months duty in a unit, and the applicable Marine Corps Institute (Mel) 0410 and 0414 distance learning correspondence courses.

d. Duties. For a complete listing of duties and tasks, refer to reference (h), Logistics Training and Readiness Manual.

e. Related SOC Classification/SOC Code

- (1) Industrial Production Managers 11-3051.
- (2) Management Analyst 13-1111.
- (3) Business Operations Specialist 13-1199.
- (4) First-Line Supervisors/Managers of Mechanics, Installers, and Repairers 49-1011.
- (5) First-Line Supervisors/Managers of Production and operating Workers 51-1010.
- (6) Maintenance and Repair Workers, General 43-5011.
- (7) Production, Planning, and Expediting Clerks 43-5061.

f. Related Military Skill. None.

APPENDIX B - 0411 T&R PERFORMANCE EVENTS

0411-ADMN-1401: Maintain maintenance administration policies/procedures

BILLETS: Maintenance Management Specialist

GRADES: PVT, PFC, LCPL, CPL, SGT

INITIAL TRAINING SETTING: FORMAL

CONDITION: Given maintenance management directives and maintenance related inspection checklist.

STANDARD: To maintain an up-to-date maintenance management program.

PERFORMANCE STEPS:

1. Review all policy letters.
2. Review all orders/directives.
3. Prepare maintenance management correspondence.
4. Maintain maintenance management correspondence/files.
5. Maintain appropriate maintenance management related inspection checklists.
6. Maintain a maintenance management office/section library.

0411-ADMN-1402: Maintain billet reference material

BILLETS: Maintenance Management Specialist

GRADES: PVT, PFC, LCPL, CPL, SGT

INITIAL TRAINING SETTING: FORMAL

CONDITION: Given the requirement to maintain a maintenance management program.

STANDARD: To establish billet duties, responsibilities and functional procedures to sustain operational capability.

PERFORMANCE STEPS:

1. Determine requirements for desktop procedures.
2. Determine requirements for turnover folders.
3. Determine requirements for Maintenance Management Standing Operating Procedures (MMSOP).
4. Assist commodity/section maintenance personnel with establishing appropriate desktop procedures or turnover folders.
5. Develop appropriate desktop procedures or turnover folders.
6. Maintain appropriate desktop procedures or turnover folders.

0411-ADMN-1403: Maintain publication control management systems

BILLETS: Maintenance Management Specialist

GRADES: PVT, PFC, LCPL, CPL, SGT

INITIAL TRAINING SETTING: FORMAL

CONDITION: Given a requirement, computer access, publication management systems, and a units TO&E.

STANDARD: To ensure the most current information is available to unit's equipment operator and maintenance support personnel.

PERFORMANCE STEPS:

1. Reconcile the unit's TO
2. Conduct on-hand publications inventory.
3. Submit deficiencies/discrepancies to the unit's Directives Control Point (DCP).
4. Update publication management systems.
5. Create an Internal Distribution Listing (IDL).
6. Incorporate changes to publications.
7. Dispose of excess/superseded publications.
8. Recommend changes to publications.
9. Monitor the submission of recommended publication changes.

0411-OPS-1401: Maintain equipment maintenance resource records/forms

BILLETS: Maintenance Management Specialist

GRADES: PVT, PFC, LCPL, CPL, SGT

INITIAL TRAINING SETTING: FORMAL

CONDITION: Given the assignment, a computer, network access, and required equipment records/forms.

STANDARD: To process, record and document the accurate status of equipment.

PERFORMANCE STEPS:

1. Extract the information for equipment resource records/forms.
2. Complete equipment resource records/forms.
3. Audit the accuracy of maintenance resource records/forms data.
4. Conduct the disposition of resource records/forms.

0411-OPS-1402: Perform functions of the maintenance automated information systems (MAIS)

BILLETS: Maintenance Management Specialist

GRADES: PVT, PFC, LCPL, CPL, SGT

INITIAL TRAINING SETTING: FORMAL

CONDITION: Given the requirement, applicable references, a computer, and network access.

STANDARD: To identify, report and document equipment maintenance requirements and operational capabilities.

PERFORMANCE STEPS:

1. Determine the supporting MAIS program.
2. Obtain access to the supporting MAIS program.
3. Input/extract MAIS data.
4. Process MAIS data.
5. Distribute MAIS data.
6. Identify MAIS maintenance and readiness transaction errors.
7. Submit MAIS program/application processing errors.
8. Conduct MAIS related training.

0411-OPS-1403: Review maintenance automated information systems (MAIS) data

BILLETS: Maintenance Management Specialist

GRADES: PVT, PFC, LCPL, CPL, SGT

INITIAL TRAINING SETTING: FORMAL

CONDITION: Given the requirement, applicable references, computer, and network access.

STANDARD: To provide accurate equipment operational availability/capability status.

PERFORMANCE STEPS:

1. Retrieve MAIS data.
2. Validate MAIS data.
3. Assess trends and discrepancies.
4. Administer corrective actions.
5. Prepare data for debrief.
6. Conduct disposition of data.

0411-OPS-1404: Conduct maintenance management related training

BILLETS: Maintenance Management Specialist

GRADES: PVT, PFC, LCPL, CPL, SGT

INITIAL TRAINING SETTING: FORMAL

CONDITION: Given personnel and references.

STANDARD: To maintain efficiency and effectiveness of a unit's maintenance management program.

PERFORMANCE STEPS:

1. Assess training deficiencies.
2. Obtain required training materials.
3. Administer the training.
4. Document attendance.
5. Record/report the training.
6. Evaluate training.

0411-OPS-1405: Reconcile maintenance operations requirements

BILLETS: Maintenance Management Specialist

GRADES: PVT, PFC, LCPL, CPL, SGT

INITIAL TRAINING SETTING: FORMAL

CONDITION: Given the resources, a computer, network access, MAIS reports, forms and records.

STANDARD: To determine the requirements in support of the unit's mission.

PERFORMANCE STEPS:

1. Complete validation procedures.
2. Review maintenance resource records, forms and reports.
3. Compare authorized stockage levels to pending requirements.
4. Determine procedures to accurately account for received items/supplies.
5. Reconcile actual equipment condition to maintenance automated information systems (MAIS) reports.

6. Review maintenance automated information systems (MAIS) reports.
7. Review pending requirements.
8. Determine external/sustainment support requirements.
9. Document reconciliation actions.
10. Initiate maintenance resource deficiencies.
11. Submit follow-up actions.

0411-OPS-1406: Administer internal management control procedures

BILLETS: Maintenance Management Specialist

GRADES: PVT, PFC, LCPL, CPL, SGT

INITIAL TRAINING SETTING: FORMAL

CONDITION: Given personnel, references, equipment, AIS reports, records and forms.

STANDARD: To ensure use of personnel, money, facilities, and materiel as applied to the maintenance of ground equipment is controlled.

PERFORMANCE STEPS:

1. Assist in inspection programs.
2. Coordinate training requirements.
3. Collect supporting documentation.
4. Evaluate policies/procedures.
5. Advise maintenance officers/commodity managers.
6. Conduct periodic physical equipment inventory review.

0411-OPS-1407: Validate maintenance resource requirements

BILLETS: Maintenance Management Specialist

GRADES: PVT, PFC, LCPL, CPL, SGT

INITIAL TRAINING SETTING: FORMAL

CONDITION: Given the requirement, a computer, network access, MAIS reports, equipment maintenance resource records, forms and reports.

STANDARD: To ensure unit possesses required resources and capabilities.

PERFORMANCE STEPS:

1. Confirm authorized level of maintenance.
2. Confirm Table of Equipment (T/E) allocations.
3. Determine types of equipment allowances.
4. Determine maintenance personnel availability.
5. Confirm classes of supply required.
6. Determine supporting tools and equipment.
7. Assess facility allocation and use.
8. Confirm publication support requirements.
9. Determine maintenance budgeting requirements.
10. Conduct maintenance reconciliation procedures.

0411-OPS-1408: Track equipment maintenance production reporting

BILLETS: Maintenance Management Specialist

GRADES: PVT, PFC, LCPL, CPL, SGT

INITIAL TRAINING SETTING: FORMAL

CONDITION: Given the appropriate resources and guidance, MAIS access, maintenance resource records, forms, reports and training schedules.

STANDARD: To report unit's equipment operational status condition.

PERFORMANCE STEPS:

1. Validate scheduled/unscheduled maintenance production function procedures.
2. Monitor equipment through the maintenance phases.
3. Coordinate equipment induction in maintenance related program.
4. Monitor the application/installation of repair parts/supplies.
5. Conduct resource availability for technical information research.
6. Monitor readiness reporting of equipment.
7. Coordinate with internal/external support activities/agencies.
8. Assess compliance of maintenance production procedures.

0411-ADMN-2401: Implement maintenance policy/procedures

BILLETS: Maintenance Management Analyst, Maintenance Management Chief, Maintenance Management Specialist

GRADES: CPL, SGT, SSGT, GYSGT, MSGT, MGYSGT

INITIAL TRAINING SETTING: FORMAL

CONDITION: Given the requirement, policy, directive, commander's guidance, and maintenance related checklist.

STANDARD: To maintain an up-to-date maintenance management program.

PERFORMANCE STEPS:

1. Direct policies/directives from higher headquarters.
2. Prepare maintenance management related correspondence, files/reports.
3. Maintain a maintenance management office correspondence file.
4. Obtain appropriate maintenance management/maintenance related inspection checklists.
5. Maintain inspection results.
6. Inspect subordinate level maintenance policies/procedures.

0411-ADMN-2402: Coordinate technical publication requirements

BILLETS: Maintenance Management Analyst, Maintenance Management Chief, Maintenance Management Specialist

GRADES: CPL, SGT, SSGT, GYSGT, MSGT, MGYSGT

INITIAL TRAINING SETTING: FORMAL

CONDITION: Given access to Publications Library Management System (PLMS), Total Force Structure Management System (TFSMS), and the unit's Publication Listing (PL).

STANDARD: To ensure required technical publications are available to support the unit's maintenance and operation effort.

PERFORMANCE STEPS:

1. Perform TO&E review.
2. Schedule Publication Listing (PL) reviews.
3. Confirm publication requirements.
4. Monitor Back Order Validation (BOV) process.
5. Document the output of the review process.
6. Record the finding of the review.
7. Monitor the internal distribution process.

0411-OPS-2401: Manage maintenance related programs

BILLETS: Maintenance Management Analyst, Maintenance Management Chief, Maintenance Management Specialist

GRADES: CPL, SGT, SSGT, GYSGT, MSGT, MGYSGT

INITIAL TRAINING SETTING: FORMAL

CONDITION: Given the requirement and resources.

STANDARD: To support equipment Total Lifecycle Systems Management (TLCSM).

PERFORMANCE STEPS:

1. Participate in Enterprise Lifecycle Maintenance Planning (ELMP).
2. Execute requirements for Depot Level Maintenance Program (DLMP).
3. Facilitate requirements for Corrosion, Prevention and Control (CPAC).
4. Synchronize Contractor Logistics Support (CLS).
5. Facilitate requirements to support Administrative Deadline/Storage Program.
6. Coordinate maintenance inspection programs.
7. Facilitate requirements for Materiel Returns Program (MRP).
8. Track Recoverable Items Program (WIR).
9. Monitor Test, Measurement, and Diagnostic Equipment (TMDE) Calibration and Maintenance Program (CAMP).
10. Coordinate warranty program.
11. Monitor quality control/assurance program.
12. Track configuration management programs.
13. Participate in prepositioning programs support.
14. Facilitate principle end item (PEI) rotation program requirement.
15. Facilitate Performance Based Logistics (PBL) requirements.

0411-OPS-2402: Monitor the operation of maintenance automated information systems (MAIS) functions

BILLETS: Maintenance Management Analyst, Maintenance Management Chief, Maintenance Management Specialist

GRADES: CPL, SGT, SSGT, GYSGT, MSGT, MGYSGT

INITIAL TRAINING SETTING: FORMAL

CONDITION: Given computer and MAIS access.

STANDARD: To ensure equipment maintenance actions and equipment condition status updates are 100% accurate.

PERFORMANCE STEPS:

1. Supervise all MAIS functional capabilities.
2. Manage duties/responsibilities for MAIS input.
3. Supervise the correction of MAIS errors for appropriate action.
4. Coordinate support requirements/operations.
5. Design MAIS use and procedures for deployment exercises and operations.
6. Validate MAIS Systems Modification Request (SMR)/change request (CR).
7. Submit MAIS trouble ticket requests to MAIS supporting activities.

0411-OPS-2403: Audit maintenance/supply resource records/forms/systems

BILLETS: Maintenance Management Analyst, Maintenance Management Chief, Maintenance Management Specialist

GRADES: CPL, SGT, SSGT, GYSGT, MSGT, MGYSGT

INITIAL TRAINING SETTING: FORMAL

CONDITION: Given the requirement and resources.

STANDARD: To verify quality control of all recorded/documented information.

PERFORMANCE STEPS:

1. Identify records/forms.
2. Verify applicable maintenance/supply resource records/forms/systems.
3. Recommend changes to maintenance/supply resource records/forms/records.
4. Assess the maintenance/supply quality control/assurance programs and procedures.
5. Record/document assessment findings.
6. Implement Continuous Process Improvement (CPI) solutions.
7. Conduct reevaluation of audit.

0411-OPS-2404: Monitor maintenance production cycle requirements

EVALUATION-CODED: NO SUSTAINMENT INTERVAL: 6 months

BILLETS: Maintenance Management Analyst, Maintenance Management Chief, Maintenance Management Specialist

GRADES: CPL, SGT, SSGT, GYSGT, MSGT, MGYSGT

INITIAL TRAINING SETTING: FORMAL

CONDITION: Given the unit TO&E, computer access, MAIS access, reports, records, forms, support databases, and supply management reports.

STANDARD: To evaluate the efficiency, safety and quality assurance of maintenance production processes and procedures.

PERFORMANCE STEPS:

1. Coordinate scheduling for command directed maintenance stand-downs.
2. Validate maintenance personnel and equipment allocations.
3. Provide guidance for maintenance measures of effectiveness (MOE).
4. Validate maintenance resources/production requirements.
5. Validate parts identification/usage/inventories.
6. Supervise field level equipment maintenance validation/reconciliation procedures.
7. Conduct specified equipment or weapon system operational availability assessments.
8. Monitor quality assurance and quality control programs for effectiveness.
9. Assist in unit's operational/maintenance planning efforts.
10. Direct participation in maintenance related programs.
11. Conduct a functional area capability assessment.
12. Ensure adherence to performance measures for Contractor Logistics Support (CLS).
13. Prepare an Appendix 12 to the Annex D.
14. Evaluate a unit's maintenance production cycle information/work flow.
15. Monitor the establishment of commodity/section safety programs.

0411-OPS-2405: Conduct maintenance/supply operations continuous process improvement (CPI) assessments

BILLETS: Maintenance Management Analyst, Maintenance Management Chief, Maintenance Management Specialist

GRADES: CPL, SGT, SSGT, GYSGT, MSGT, MGYSGT

INITIAL TRAINING SETTING: FORMAL

CONDITION: Given the requirement and resources.

STANDARD: To increase materiel readiness in support of equipment availability and operational planning.

PERFORMANCE STEPS:

1. Complete Continuous Process Improvement (CPI) training.
2. Identify different types of CPI methods and concepts.
3. Monitor personnel and equipment allowance reviews.
4. Monitor applicable maintenance performance measures and metrics.
5. Evaluate past unit inspections and evaluations.
6. Perform CPI reviews of the unit's maintenance, supply, transportation, and distribution processes and procedures.
7. Provide CPI recommendations to increase process/procedures efficiency and effectiveness.
8. Implement CPI controls/recommendations.
9. Document CPI initiatives.

0411-OPS-2406: Monitor supply support requirements

BILLETS: Maintenance Management Analyst, Maintenance Management Chief, Maintenance Management Specialist

GRADES: CPL, SGT, SSGT, GYSGT, MSGT, MGYSGT

INITIAL TRAINING SETTING: FORMAL

CONDITION: Given computer access, requirements, and resources.

STANDARD: To assess equipment availability for sustained operations.

PERFORMANCE STEPS:

1. Coordinate new equipment fielding requirements.
2. Conduct supply support assessments.
3. Monitor maintenance/supply validation process.
4. Monitor maintenance/supply reconciliation process.
5. Monitor supply/distribution support programs.
6. Supervise support/special equipment allowances.
7. Assist in the preparation of unit Operations & Maintenance (O&M) field budget planning/requirements.
8. Monitor contractor logistics support (CLS).
9. Monitor supply performance measures and metrics.
10. Monitor supporting asset visibility information tools.
11. Enforce Uniform Materiel Management Information Processing System (UMMIPS).

0411-OPS-2407: Conduct equipment condition reporting assessment

BILLETS: Maintenance Management Analyst, Maintenance Management Chief, Maintenance Management Specialist

GRADES: CPL, SGT, SSGT, GYSGT, MSGT, MGYSGT

INITIAL TRAINING SETTING: FORMAL

CONDITION: Given resources and a requirement.

STANDARD: To ensure the units equipment readiness and ability to perform its mission.

PERFORMANCE STEPS:

1. Determine equipment readiness reporting requirements.
2. Validate status of reportable equipment.
3. Analyze data for reporting trends.
4. Develop courses of action to enhance equipment readiness reporting.
5. Coordinate with personnel on equipment availability.
6. Conduct a Readiness brief/report.

APPENDIX C - 0431 MOS DESCRIPTION

MOS 0431, Logistics/Embarkation Specialist (SSgt to Pvt) PMOS

a. Summary. The logistics/embarkation specialist prepares supplies and equipment for embarkation and performs various Force Deployment Planning and Execution (FDP&E) functions to support the movement of personnel, supplies, and equipment via all modes of transportation using commercial and military assets, at all levels including unit, MAGTF, and joint operations. They are trained in the application of Automated Information Systems (AIS) that are utilized throughout the Defense Transportation System (DTS) to account, track, and interface movement data with load planning programs and joint AIS to support the FDP&E process and In Transit Visibility (ITV). The logistics/embarkation specialist is trained to prepare aircraft and ship load plans that meet organizational requirements. They assist with the preparation, planning, and execution of strategic mobility plans in accordance with the Time Phased Force Deployment Data (TPFDD) used to deploy and sustain forward deployed forces. The logistics/embarkation specialist also performs multiple logistics administrative duties within the J/G/S-4 section. They compile and maintain logistics support data, compute combat logistics support requirements, and coordinate combat logistics functions in support of MAGTF operations and deployments. At the SNCO level, they will also serve as Combat Cargo Assistants (CCAs) onboard naval amphibious assault Ships. MOS 0491, Logistics/Mobility Chief is assigned as the primary MOS upon promotion to Gunnery Sergeant.

b. Prerequisites

- (1) Must be a U.S. Citizen.
- (2) Security requirement: secret security clearance eligibility.
- (3) Must possess a GT score of 100 or higher.

c. Requirements

- (1) Complete the Basic Logistics/Embarkation Specialist Course, Logistics Operations School, Marine Corps Combat Service Support Schools, Camp Johnson/Camp Lejeune, NC, upon entry or lateral move at the rank of Sergeant or below.
- (2) Sergeants making a lateral move must also complete the Logistics/Embarkation NCO Course, Logistics Operations School, Marine Corps Combat Service Support Schools, Camp Johnson/Camp Lejeune, NC.

d. Duties. For a complete listing of duties and tasks, refer to reference (h) Logistics Training and Readiness Manual.

e. Related SOC Classification/SOC Code

- (1) Cargo and Freight Agent 43-5011.
- (2) Production, Planning and Expediting Clerks 43-5061

f. Related Military Skill

- (1) Traffic Management Specialist, 3112.
- (2) Administrative, Clerk 0151.

APPENDIX D - 0431 T&R PERFORMANCE EVENTS

0431-EXCU-1301: Perform unit asset tracking functions

GRADES: PVT, PFC, LCPL, CPL, SGT

INITIAL TRAINING SETTING: FORMAL

CONDITION: Given the assignment as a unit Embarkation Clerk, a concept of operations, applicable logistics AIS and the references.

STANDARD: To ensure 100% accountability (supplies and equipment).

PERFORMANCE STEPS:

1. Identify unit asset tracking requirements.
2. Identify the level of asset tracking required for the deployment.
3. Determine Military Shipping Label (MSL) requirements.
4. Generate MSLs for unit cargo.
5. Determine Radio Frequency Identification (RFID) tag requirements for unit cargo.
6. Set up unit level AIT equipment.
7. Track unit equipment and cargo locations using AIT.
8. Generate unit equipment and cargo location reports using AIS.

0431-LOGR-1501: Prepare supplies and equipment for embarkation

GRADES: PVT, PFC, LCPL, CPL, SGT

INITIAL TRAINING SETTING: FORMAL

CONDITION: Given supplies and equipment to be embarked, necessary tools, equipment, references, and assignment to conveyance.

STANDARD: To meet unit move requirements in accordance with conveyance restraints.

PERFORMANCE STEPS:

1. Reconcile unit move AIS data with physical characteristics of equipment to be embarked.
2. Identify unit hazardous materials that require certification.
3. Check warehouse pallets for serviceability.
4. Verify unit containers for serviceability.
5. Check 463L pallet system for serviceability.
6. Check tie down equipment for serviceability.
7. Ensure adequate dunnage/shoring is on hand.
8. Ensure unit embarkation boxes/cases are packed properly.
9. Ensure equipment liquid levels meet conveyance requirements.
10. Ensure unit equipment is palletized properly.
11. Ensure unit containers are packed properly.
12. Ensure unit rolling stock is prepared properly.
13. Ensure required embarkation markings are present on unit supplies and equipment.
14. Verify required ITV/RFID actions are complete ISO embarkation.

0431-LOGR-1502: Perform unit level logistics functions

GRADES: PVT, PFC, LCPL, CPL, SGT

INITIAL TRAINING SETTING: FORMAL

CONDITION: Given the assignment as a unit Logistics Clerk, a concept of operations, applicable logistics AIS and the references.

STANDARD: IAW the units SOP.

PERFORMANCE STEPS:

1. Identify unit logistics functions.
2. Maintain correspondence files.
3. Prepare naval correspondence.
4. Maintain a logistics publications library.
5. Prepare logistics support requests (LSR).
6. Maintain logistics status boards.
7. Maintain Logistics Clerk desktop procedures.
8. Provide logistics information for letters of instruction (LOIs).
9. Provide information for logistics briefs and reports.

0431-LOGR-1803: Prepare embarkation reports

GRADES: PVT, PFC, LCPL, CPL, SGT

INITIAL TRAINING SETTING: FORMAL

CONDITION: Given the assignment as a unit Embarkation Clerk, a concept of operations, applicable AIS and the references.

STANDARD: To support the unit's embarkation readiness.

PERFORMANCE STEPS:

1. Identify unit embarkation reports.
2. Produce unit embarkation personnel reports.
3. Produce unit embarkation readiness reports.
4. Produce unit move AIS data reconciliation reports.

0431-PLAN-1801: Perform unit move automated information systems (AIS) functions

GRADES: PVT, PFC, LCPL, CPL, SGT

INITIAL TRAINING SETTING: FORMAL

CONDITION: Given automated information systems (AIS), automated information technology (AIT) components, logistics and embarkation data, and guidance.

STANDARD: To meet force deployment planning & execution process (FDP&E) requirements.

PERFORMANCE STEPS:

1. Perform user access admin functions.
2. Perform data library admin functions.
3. Create a unit garrison database.
4. Perform records management functions.
5. Perform asset association functions.
6. Perform report functions.
7. Perform database reconciliations.
8. Create deployment plans.
9. Perform automated information technology (AIT) functions.
10. Perform In-Transit Visibility (ITV) functions.
11. Perform data interface functions.
12. Perform load plan functions using interface data and the approved AIS.

0431-EXCU-2301: Certify hazardous material for shipment

GRADES: LCPL, CPL, SGT, SSGT, GYSGT, WO, CWO2, CWO3, CAPT

INITIAL TRAINING SETTING: FORMAL

CONDITION: Given references, certification, appointment as a unit hazardous material certifier, cargo containing hazardous material and required forms.

STANDARD: Per MCO P4030.19_.

PERFORMANCE STEPS:

1. Identify certification requirements.
2. Ensure hazardous cargo is properly packaged, marked and labeled.
3. Certify hazardous cargo using required forms for dangerous goods.
4. Ensure hazardous cargo is properly separated and segregated.
5. Ensure proper care in handling hazardous cargo.
6. File documentation, as required.

ADMINISTRATIVE INSTRUCTIONS: This is a formal school conducted by the Air Force, Army, and Navy commands.

0431-EXCU-2302: Coordinate unit marshalling operations

GRADES: LCPL, CPL, SGT, SSGT

INITIAL TRAINING SETTING: MOJT

CONDITION: Given embarkation plan, unit data, and AIS.

STANDARD: To ensure all assets are consolidated and prepared in time to support the embarkation plan.

PERFORMANCE STEPS:

1. Identify marshalling area requirements.
2. Identify the marshalling area.
3. Coordinate logistics requirements.
4. Coordinate communications.
5. Develop unit marshalling area diagrams depicting the segregation of supplies and equipment into sequence for loading.
6. Brief personnel on marshalling plans, schedules, ORM, and diagrams.
7. Schedule inspections as required.
8. Report status of movement to Movement Control Center (MCC).

0431-EXCU-2303: Support unit amphibious embarkation operations

BILLETS: Embarkation Chief, Embarkation NCO, Team Embarkation Assistant, Team Embarkation Officer

GRADES: CPL, SGT, SSGT

INITIAL TRAINING SETTING: FORMAL

CONDITION: Given assignment to shipping, ship loading characteristics pamphlet (SLCP), ships troop regulations, unit embarkation data, landing plan, Landing Force Operational Reserve Materiel (LFORM) supplement, and AIS.

STANDARD: To support embarked assets ship-to-shore movement requirements in accordance with the landing plan.

PERFORMANCE STEPS:

1. Review the Organization for Embarkation and Assignment to Shipping (OE&AS).
2. Review the landing plan.
3. Review the SLCP.
4. Review Embarked Troop Regulations.
5. Validate deployment data for landing force assets.
6. Complete the ship/landing craft load plan.
7. Reconcile the load plan with the SLCP.
8. Ensure landing force equipment is prepared for embarkation.
9. Review amphibious onload/offload documentation.
10. Ensure landing force assets are staged for embarkation.
11. Identify embarkation requirements.
12. Report the status of embarkation.
13. Reconcile load plan upon completion of ship load.
14. Submit landing force data to the ships Combat Cargo Officer for completion of the Embarked Personnel and Materials Report (EPMR).
15. Coordinate customs and agricultural clearance, as required.

0431-EXCU-2304: Perform asset tracking functions

BILLETS: Embarkation Chief, Embarkation NCO

GRADES: CPL, SGT, SSGT

INITIAL TRAINING SETTING: FORMAL

CONDITION: Given the deployment data, mode & source, and access to the AIS.

STANDARD: In compliance with DOD ITV policies.

PERFORMANCE STEPS:

1. Verify unit cargo meets ITV requirements.
2. Perform unit move AIS ITV requirements.
3. Perform unit move AIS ITV interfaces.
4. Monitor unit cargo air movement by mission number using Single Mobility System (SMS).
5. Monitor unit passenger air movement by mission number using SMS.
6. Monitor unit sealift movement by mission number using SMS.
7. Monitor unit cargo air movement by Transportation Control Number (TCN) using SMS.
8. Monitor unit passenger air movement by TCN using SMS.
9. Monitor unit cargo movement by TCN using the national RFID server.
10. Monitor unit cargo movement by tag ID using the national RFID server.
11. Monitor unit cargo movement by TCN using Integrated Development Environment/Global Transportation Network Convergence (IGC).
12. Report the status of unit movement.

0431-EXCU-2305: Support commercial ship loading operations

BILLETS: Embarkation Chief, Embarkation NCO

GRADES: CPL, SGT, SSGT

INITIAL TRAINING SETTING: FORMAL

CONDITION: Given a commercial ship, loading data, and access to AIS.

STANDARD: To support embarked asset movement requirements in accordance with the Time Phased Force Deployment Data (TPFDD).

PERFORMANCE STEPS:

1. Prepare commercial ship documentation, as required.
2. Prepare supplies & equipment for commercial ship loading.
3. Coordinate vessel loading.
4. Assist in the preparation of ship loading reports.
5. Coordinate customs and agricultural clearance, as required.

0431-EXCU-2306: Support unit air embarkation

BILLETS: Embarkation Chief, Embarkation NCO

GRADES: CPL, SGT, SSGT

INITIAL TRAINING SETTING: FORMAL

CONDITION: Given a requirement, deployment information, aircraft allocation, equipment to deploy, and AIS.

STANDARD: To support embarked asset movement in accordance with the requirement.

PERFORMANCE STEPS:

1. Provide initial aircraft load plan.
2. Provide Hazardous Material Diplomatic Clearance (HAZDIP), as required.
3. Review aircraft allocation.
4. Ensure TCNs are assigned.
5. Validate air transportability certification.
6. Ensure unit cargo and equipment is prepared.
7. Ensure unit cargo and equipment is staged for movement.
8. Coordinate movement of unit cargo and equipment to APOE.
9. Ensure unit cargo and equipment is compliant with inspection requirements.
10. Ensure certified aircraft load plan is provided.
11. Ensure the designated agency provides passengers manifests.
12. Ensure passengers are staged in accordance with movement requirements.
13. Coordinate the loading of unit cargo and equipment aboard aircraft.
14. Coordinate the embarkation of unit passengers aboard aircraft.
15. Reconcile aircraft load plan upon completion of loading.
16. Track unit mission status.
17. Coordinate customs and agricultural clearance, as required.

0431-EXCU-2307: Support unit rail embarkation execution

BILLETS: Embarkation Chief, Equipment NCO

GRADES: CPL, SGT, SSGT

INITIAL TRAINING SETTING: MOJT

CONDITION: Given rail assets, a movement plan, equipment, and access to AIS.

STANDARD: To support embarked asset movement in accordance with the requirement.

PERFORMANCE STEPS:

1. Submit unit move AIS data to required agencies.
2. Ensure unit cargo and equipment is prepared.
3. Ensure unit cargo and equipment is staged.
4. Ensure unit cargo and equipment is compliant with lift providers inspection requirements.
5. Coordinate logistics requirements.
6. Monitor the loading of unit assets.
7. Submit required reports.
8. Monitor unit rail movement via ITV.

0431-EXCU-2708: Coordinate unit move transportation

GRADES: CPL, SGT, SSGT

INITIAL TRAINING SETTING: MOJT

CONDITION: Given a requirement to conduct transportation planning, transportation planning AIS, unit embarkation data, and references.

STANDARD: To ensure unit move requirements are supported.

PERFORMANCE STEPS:

1. Ensure unit move transportation requests are consolidated.
2. Ensure unit move transportation requests are submitted in accordance with local SOP.
3. Coordinate with designated movement control agencies.
4. Coordinate the transportation of assets/personnel.
5. Coordinate MHE support for the movement as required.

0431-EXCU-2809: Execute FDP&E unit move AIS functions

BILLETS: Embarkation Chief, Embarkation NCO

GRADES: CPL, SGT, SSGT

INITIAL TRAINING SETTING: FORMAL

CONDITION: Given a concept of operations, a force requirement, AIS, unit assets to be embarked, and references.

STANDARD: To ensure unit move requirements are accurately represented in the joint movement systems for allocation of lift.

PERFORMANCE STEPS:

1. Import force requirement.

2. Source the force requirement.
3. Compile accompanying supply list(s).
4. Insert accompanying supply lift requirements into unit move AIS.
5. Edit accompanying supply lift requirements within unit move AIS.
6. Create deployment package.
7. Perform a force requirement interface.
8. Validate force requirement in the Time-Phased Force Deployment Data (TFFDD).
9. Interface unit move data with load plan AIS.
10. Interface unit move data with DOD ITV systems.

0431-EXCU-2810: Prepare a Special Assignment Airlift Mission (SAAM) request

BILLETS: Embarkation Chief, Embarkation NCO

GRADES: CPL, SGT, SSGT

INITIAL TRAINING SETTING: FORMAL

CONDITION: Given the requirement to conduct airlift planning for a unit deployment, air load planning AIS, unit move AIS, and references.

STANDARD: In accordance with Defense Transportation Regulation (DTR).

PERFORMANCE STEPS:

1. Identify SAAM requirements.
2. Compile SAAM requirements.
3. Submit SAAM request.

0431-LOGR-2501: Conduct unit embarkation training

BILLETS: Embarkation Chief, Embarkation NCO

GRADES: CPL, SGT, SSGT

INITIAL TRAINING SETTING: FORMAL

CONDITION: Given unit embarkation personnel, section/company embarkation representatives, and references.

STANDARD: In accordance with MCO 1553.3A, Unit Training Management (UTM).

PERFORMANCE STEPS:

1. Reference NAVMC 3500.27_ for required training events for embarkation personnel.
2. Determine training requirements for section/company embarkation representatives.
3. Determine existing training level.
4. Identify training deficiencies.
5. Develop a training plan.
6. Schedule formal schools seats for required training.
7. Schedule unit level training.
8. Develop training materials.
9. Develop training evaluation tools.
10. Coordinate training support requirements.
11. Conduct unit embarkation training.
12. Evaluate unit embarkation training.
13. Document T&R events trained.
14. Report T&R event training to higher headquarters.

ADMINISTRATIVE INSTRUCTIONS: This distance learning product is provided by MarineNET, on-line learning. "Unit Training Management" CID: UT03AO

0431-LOGR-2502: Manage unit embarkation readiness program

BILLETS: Embarkation Chief

GRADES: CPL, SGT, SSGT

INITIAL TRAINING SETTING: MOJT

CONDITION: Given references, embarkation personnel, readiness requirements, and assigned to a deployable unit.

STANDARD: IAW MCRP 4-11.3_ Unit Embarkation Handbook.

PERFORMANCE STEPS:

1. Ensure section EDLs are accurately reflected in unit move AIS data.
2. Ensure the unit has a mobile load plan.
3. Ensure mobile loads are prepared, as required.
4. Ensure the unit has a containerization plan.
5. Ensure unit containers are serviceable.
6. Ensure the unit has required embarkation materials on hand.
7. Ensure the unit has procedures for procuring required embarkation materials.
8. Ensure the unit has identified a 463L pallet requirement.

9. Ensure that cargo is marked properly.
10. Ensure the unit has hazardous material certifiers designated.
11. Ensure the unit has certified Air Load planners designated.
12. Complete training requirements for section/company embarkation representatives.
13. Conduct MOS training as prescribed by NAVMC 3500.27_.
14. Conduct embarkation readiness inspections.

0431-LOGR-2503: Perform unit logistics section functions

BILLETS: Logistics NCO

GRADES: CPL, SGT

INITIAL TRAINING SETTING: MOJT

CONDITION: Given the assignment to a unit logistics section, AIS, and references.

STANDARD: Meeting unit logistics requirements.

PERFORMANCE STEPS:

1. Ensure compliance with logistics references.
2. Manage logistics correspondence files.
3. Manage input to logistics status boards and reports.
4. Maintain logistics desktop procedures/turnover procedures.
5. Prepare naval correspondence.
6. Assist in the completion of logistics LOIs.
7. Review logistics information for logistics briefs and reports.
8. Provide logistics briefs and reports as required.
9. Supervise a units facilities management program.
10. Support unit AA&E operations.
11. Maintain publications library.

0431-LOGR-2504: Determine lift requirements

BILLETS: Logistics Chief, Logistics NCO

GRADES: CPL, SGT, SSGT

INITIAL TRAINING SETTING: FORMAL

CONDITION: Given a requirement, a concept of operations, AIS, and references.

STANDARD: To meet the requirement.

PERFORMANCE STEPS:

1. Determine personnel density.
2. Determine equipment density.
3. Compute supply class requirements.
4. Determine supply classes lift requirements.

0431-LOGR-2505: Certify intermodal containers for shipment

GRADES: CPL, SGT, SSGT, WO, CWO2, CWO3, CAPT

INITIAL TRAINING SETTING: DISTLEARN

CONDITION: Given intermodal containers, container inspection checklist, and the supplies to certify intermodal containers.

STANDARD: IAW DOD 4500.9-R Defense Transportation Regulations.

PERFORMANCE STEPS:

1. Inspect intermodal container (s) for transportability.
2. Certify intermodal container (s) for transportability.

ADMINISTRATIVE INSTRUCTIONS: Intermodal Dry Cargo Container (CSC) Reinspection Course, U.S. Army Defense Ammunition Center, McAlester, OK. CID: A33LAS1

0431-LOGR-2506: Perform combat cargo duties

BILLETS: Combat Cargo Assistant

GRADES: SSGT

INITIAL TRAINING SETTING: MOJT

CONDITION: Given the assignment as the ship's CCA and references.

STANDARD: IAW MCRP 4-11C Combat Cargo Operations Handbook.

PERFORMANCE STEPS:

1. Assist in preparation and distribution of SLCP.
2. Assist in the preparation and distribution of Embarked Troop Regulations.
3. Create LFORM supplement in current AIS.
4. Coordinate Ships Platoon integration.
5. Coordinate Combat Cargo Platoon training.
6. Establish and maintain liaison with the landing force.

7. Ensure landing force spaces are maintained.
8. Support ship-to-shore movement of the landing force.
9. Coordinate the support of Landing Force requirements.

0431-PLAN-2801: Compute cost estimates for transportation

BILLETS: Embarkation Chief, Equipment NCO

GRADES: CPL, SGT, SSGT

INITIAL TRAINING SETTING: FORMAL

CONDITION: Given a concept of operations, historical data, and references.

STANDARD: To ensure costs are estimated accurately and funding deficiencies are identified, per the references.

PERFORMANCE STEPS:

1. Compile lift requirements.
2. Compute the estimated costs of transportation by conveyance.

0431-PLAN-2802: Supervise unit move AIS administration

BILLETS: Embarkation Chief, Embarkation NCO

GRADES: CPL, SGT, SSGT

INITIAL TRAINING SETTING: FORMAL

CONDITION: Given concept of operations, AIS, and references.

STANDARD: To ensure all unit move requirements are identified in unit move AIS.

PERFORMANCE STEPS:

1. Install unit move AIS.
2. Perform unit move AIS system administrator functions.
3. Edit unit move AIS plan data.
4. Verify MDL update completion.
5. Edit unit move AIS tech data.
6. Manage garrison database.
7. Install load plan AIS.
8. Perform load plan AIS admin functions.
9. Manage load plan AIS user access.
10. Update load plan AIS.

0431-PLAN-2803: Prepare an amphibious ship load plan

BILLETS: Embarkation Chief, Embarkation NCO, Team Embarkation Assistant, Team Embarkation Officer

GRADES: LCPL, CPL, SGT, SSGT

INITIAL TRAINING SETTING: FORMAL

CONDITION: Given an Organization for Embarkation and Assignment to Shipping (OE&AS), Ship Loading Characteristics Pamphlet (SLCP), a landing plan/offload sequence, unit embarkation data, unit move AIS, load plan AIS, and references.

STANDARD: To meet ship-to-shore movement requirements.

PERFORMANCE STEPS:

1. Review the OE&AS.
2. Consolidate embarkation team data.
3. Validate the embarkation team data.
4. Review the landing plan.
5. Assign offload priority numbers.
6. Perform unit move AIS to load plan AIS interface.
7. Create a ship load plan using AIS.
8. Create landing craft load plans.
9. Complete load plan documentation.
10. Submit load plan documents for approval.

0431-PLAN-2804: Prepare an aircraft load plan

BILLETS: Embarkation Chief, Embarkation NCO

GRADES: CPL, SGT, SSGT

INITIAL TRAINING SETTING: FORMAL

CONDITION: Given unit embarkation data, type of aircraft, load plan AIS, and references.

STANDARD: To ensure compliance with the characteristics of assigned aircraft per references.

PERFORMANCE STEPS:

1. Validate suitability of equipment for aircraft load planning.
2. Identify all cargo requiring special handling.
3. Validate air transportability certification.
4. Calculate center of balance for completed load plan.
5. Print a computer generated load plan.
6. Certify load plan, as required.

APPENDIX E - 0481 MOS DESCRIPTION

MOS 0481, Landing Support Specialist (SSgt to Pvt) PMOS

a. Summary. The landing support specialist performs various duties that support the establishment, maintenance and control of transportation throughput systems on beaches, landing zones, ports (air and sea), and terminals (rail, truck, and container) used in support of MAGTF operations and deployments. They are trained in the doctrinal concepts of landing support and the landing force support party conducting port, arrival/departure airfield, helicopter landing zone, and railhead operations. The landing support specialist is also trained in the application of Automated Information Systems (AIS) that are utilized throughout the Defense Transportation System (DTS) to track, and interface movement data with load planning programs and joint AIS to support the FDP&E process and In Transit Visibility (ITV). NCOs and Staff NCOs plan, conduct, and supervise landing support operations and training. At the MAGTF level, they assist with the throughput of unit personnel, supplies and equipment. They also assist with the preparation, planning, and execution of strategic mobility plans in accordance with the Time Phased Force Deployment Data (TPFDD) used to deploy and sustain forward deployed forces. At the SNCO level, they will also serve as Combat Cargo Assistants (CCAs) onboard naval amphibious assault ships. MOS 0491, Logistics/Mobility Chief is assigned as the primary MOS upon promotion to Gunnery Sergeant.

b. Prerequisites

- (1) Must be a U.S. Citizen.
- (2) Security requirement: Secret security clearance eligibility.
- (3) Must possess a GT score of 95 or higher.
- (4) Must possess an MM score of 100 or higher.

c. Requirements

- (1) Complete the Basic Landing Support Specialist Course, Logistics Operations School, Marine Corps Combat Service Support Schools, Camp Johnson/Camp Lejeune, Ne, upon entry or upon lateral move at the rank of Sergeant or below.
- (2) Sergeants making a lateral move must also complete the Landing Support NCO Course, Logistics Operations School, Marine Corps Combat Service Support Schools, Ca.mp Johnson/Camp Lejeune, NC.
- (3) Non-MOS qualified Reserve Marines unable to attend the regular formal school course may be certified for MOS 0481, as an AMOS-only, by the unit commander upon successful completion of the Alternate Training Instructional Program (ATIP) of the Marine Force Reserves. The ATIP for MOS 0481 Marines is found in Force Order 1535.1 and consists of core tasks to be performed to standard at the Reserve Basic Landing Support School, MTT or MOJT. A minimum of six months MOJT while assigned to MOS 0481 billet is required.

d. Duties. For a complete listing of duties and tasks, refer to reference (h), Logistics Training and Readiness Manual.

e. Related SOC Classification/SOC Code. Military Enlisted Tactical Operations and Air/Weapons Specialists and Crew Members, All Other 55-3019.

f. Related Military Skill. None.

APPENDIX F - 0481 T&R PERFORMANCE EVENTS

0481-OPS-1401: Conduct helicopter support team (HST) operations

GRADES: PVT, PFC, LCPL, CPL, SGT, SSGT

INITIAL TRAINING SETTING: FORMAL

CONDITION: Given a task, personnel, equipment, tools, facilities and references.

STANDARD: To transport all required equipment and personnel.

PERFORMANCE STEPS:

1. Perform individual task(s) as required.
2. Establish communication.
3. Clear LZ.
4. Mark LZ.
5. Prepare load for lifting.
6. Stage PAX for loading.
7. Direct aircraft.
8. Perform internal loading operations.
9. Perform external lift hookup operations.

0481-OPS-1402: Conduct rail operations

BILLETS: Landing Support Specialist

GRADES: PVT, PFC, LCPL, CPL, SGT

INITIAL TRAINING SETTING: FORMAL

CONDITION: Given a task, personnel, equipment, tools, facilities and references.

STANDARD: To load all required equipment for transportation.

PERFORMANCE STEPS:

1. Perform individual task(s) as required.
2. Identify rail car characteristics.
3. Perform automated information technology functions.
4. Direct loading/unloading of rail cars.
5. Tie down vehicle.

0481-OPS-1403: Conduct port operations

BILLETS: Landing Support Specialist

GRADES: PVT, PFC, LCPL, CPL, SGT, SSGT

INITIAL TRAINING SETTING: FORMAL

CONDITION: Given a task, personnel, equipment, tools, facilities and references.

STANDARD: To complete operation with 100% accountability.

PERFORMANCE STEPS:

1. Perform individual task(s) as required.
2. Identify ship characteristics.
3. Perform automated information technology functions.
4. Direct equipment movement for loading/offloading.
5. Direct PAX movement for loading/offloading.

CHAINED EVENTS: LOG-OPS-3708

0481-OPS-1404: Conduct beach operations

BILLETS: Landing Support Specialist

GRADES: PVT, PFC, LCPL, CPL, SGT, SSGT

INITIAL TRAINING SETTING: FORMAL

CONDITION: Given a task, personnel, equipment, tools, facilities and references.

STANDARD: To complete ship-to-shore operations IAW the landing plan.

PERFORMANCE STEPS:

1. Perform individual task(s) as required.
2. Identify landing craft characteristics.
3. Set up beach landing zones.
4. Submit required reports.
5. Perform automated information technology functions.
6. Direct equipment movement for loading/offloading.
7. Anchor the panels.

0481-OPS-1405: Conduct arrival airfield control group/departure airfield control group (A/DACG) operations

BILLETS: Landing Support Specialist

GRADES: PVT, PFC, LCPL, CPL, SGT, SSGT

INITIAL TRAINING SETTING: FORMAL

CONDITION: Given a task, personnel, equipment, tools, facilities and references.
STANDARD: To support air movement operations IAW the references.

PERFORMANCE STEPS:

1. Perform individual task(s) as required.
2. Identify aircraft characteristics.
3. Identify material handling equipment requirements.
4. Direct equipment movement for loading/offloading.
5. Direct PAX movement for loading/offloading.

0481-ADMN-2401: Perform in-transit visibility (ITV) functions

BILLETS: Landing Support Detachment Chief, Landing Support Platoon Sergeant, Landing Support Specialist, Logistics Chief

GRADES: CPL, SGT, SSGT

INITIAL TRAINING SETTING: FORMAL

CONDITION: Given a task, unit deployment data, personnel and In-Transit Visibility (ITV) assets.

STANDARD: To ensure visibility of all assets during transit.

PERFORMANCE STEPS:

1. Determine ITV asset requirements.
2. Inventory ITV assets.
3. Inspect ITV assets.
4. Assemble ITV assets.
5. Implement ITV assets.
6. Validate upload of unit data into DOD ITV systems.
7. Verify asset tracking using DOD ITV systems.

0481-OPS-2401: Certify drop zone/landing zone for rotary wing, fixed wing, and tilt rotary aircraft

BILLETS: Landing Support Detachment Chief, Landing Support Platoon Sergeant, Landing Support Specialist, Logistics Chief

GRADES: CPL, SGT, SSGT

INITIAL TRAINING SETTING: FORMAL

CONDITION: Given a task, personnel, equipment, tools, facilities and references.

STANDARD: To ensure that DZ/LZ support CSS operations.

PERFORMANCE STEPS:

1. Identify DZ/LZ area.
2. Conduct site survey.
3. Determine marking requirements.
4. Coordinate support.

0481-PLAN-2701: Plan helicopter support team (HST) operations

BILLETS: Landing Support Detachment Chief, Landing Support Platoon Sergeant, Landing Support Specialist, Logistics Chief

GRADES: CPL, SGT, SSGT

INITIAL TRAINING SETTING: FORMAL

CONDITION: Given a task, personnel, equipment, tools, facilities and references.

STANDARD: To ensure 100% accountability and timely throughput of required equipment and personnel.

PERFORMANCE STEPS:

1. Determine requirements.
2. Coordinate support.
3. Conduct reconnaissance.
4. Provide input as required.
5. Conduct confirmation brief.
6. Implement procedures.

0481-PLAN-2702: Plan port operations

BILLETS: Landing Support Detachment Chief, Landing Support Platoon Sergeant, Landing Support Specialist, Logistics Chief

GRADES: CPL, SGT, SSGT

INITIAL TRAINING SETTING: FORMAL

CONDITION: Given a task, personnel, equipment, tools, facilities and references.

STANDARD: To ensure 100% accountability and timely throughput of required equipment and personnel.

PERFORMANCE STEPS:

1. Determine requirements.
2. Coordinate support.
3. Conduct site survey.
4. Provide input as required.
5. Conduct confirmation brief.
6. Implement procedures.

0481-PLAN-2703: Plan beach operations

BILLETS: Landing Support Detachment Chief, Landing Support Platoon Sergeant, Landing Support Specialist, Logistics Chief

GRADES: CPL, SGT, SSGT

INITIAL TRAINING SETTING: FORMAL

CONDITION: Given a task, personnel, equipment, tools, facilities and references.

STANDARD: To ensure 100% accountability and timely throughput of required equipment and personnel.

PERFORMANCE STEPS:

1. Determine requirements.
2. Coordinate support.
3. Conduct recon.
4. Provide input as required.
5. Conduct confirmation brief.
6. Implement procedures.

0481-PLAN-2704: Plan Arrival Airfield Control Group/Departure Airfield Control Group (A/DACG) operations

BILLETS: Landing Support Detachment Chief, Landing Support Platoon Sergeant, Landing Support Specialist, Logistics Chief

GRADES: CPL, SGT, SSGT

INITIAL TRAINING SETTING: FORMAL

CONDITION: Given a task, personnel, equipment, tools, facilities and references.

STANDARD: To ensure 100% accountability and timely throughput of required equipment and personnel.

PERFORMANCE STEPS:

1. Determine requirements.
2. Coordinate support.
3. Provide input as required.
4. Conduct confirmation brief.
5. Implement procedures.

0481-PLAN-2705: Plan rail operations

BILLETS: Landing Support Detachment Chief, Landing Support Platoon Sergeant, Landing Support Specialist, Logistics Chief

GRADES: CPL, SGT, SSGT

INITIAL TRAINING SETTING: FORMAL

CONDITION: Given a task, personnel, equipment, tools, facilities and references.

STANDARD: To ensure 100% accountability and timely throughput of required equipment and personnel.

PERFORMANCE STEPS:

1. Determine requirements.
2. Coordinate support.
3. Conduct site survey.
4. Provide input as required.
5. Conduct confirmation brief.
6. Implement procedures.

0481-PLAN-2706: Plan combat service support (CSS)

BILLETS: Logistics Chief

GRADES: SSGT

INITIAL TRAINING SETTING: FORMAL

CONDITION: Given a task, personnel, equipment, tools, facilities and references.

STANDARD: To ensure all CSS requirements are met.

PERFORMANCE STEPS:

1. Determine requirements.
2. Coordinate support.
3. Provide input as required.
4. Implement procedures.

APPENDIX G - 0491 MOS DESCRIPTION

MOS 0491, Logistics/Mobility Chief (MGySgt to GySgt) PMOS

a. Summary. The logistics/mobility chief coordinates, plans, conducts and supervises logistics, embarkation, and landing support operations throughout the Marine Corps. They are also responsible for unit level logistics and embarkation training. They coordinate all combat logistics functions to deploy and sustain Marine combat forces of a MAGTF and its attached units. Logistics/mobility chiefs also serve as Combat Cargo Assistants (CCAs) onboard naval amphibious staffs and ships. They serve on General Officer staffs at the MEF, MARFOR, and HQMC level and conduct planning and execution of MAFTF deployments at the strategic level. Logistics/mobility chiefs articulate command strategic mobility requirements both present and future to appropriate agencies, such as; Headquarters Marine Corps, U.S. Transportation Command and her three Transportation Component Commands (TCCs); Surface Deployment Distribution Command, Military Sealift Command, and Air Mobility Command. As the logistics/mobility chiefs' career progresses, they are assigned to Naval and Joint staffs as a liaison for the Marine Corps where they provide interface and address Marine Corps' mobility and lift requirements. They can also be assigned to serve with the TCCs as liaisons to convey the MAGTF commander's operational requirements to support unit moves at the operational/strategic level.

b. Prerequisites. Must have had previous duty as a 0431, or 0481.

c. Requirements. Complete the Advanced Logistics/Mobility Course, Logistics Operations School, Marine Corps Combat Service Support Schools, Camp Johnson/Camp Lejeune, NC, as a Staff Sergeant or Gunnery Sergeant.

d. Duties. For a complete listing of duties and tasks, refer to reference (h), Logistics Training and Readiness Manual.

e. Related SOC Classification/SOC Code. First-Line Supervisors/Managers of Officer and Administrative Support Workers 43-1011.

f. Related Military Skill. Traffic Management Specialist, 3112.

APPENDIX H - 0491 T&R PERFORMANCE EVENTS

0491-ENG-2001: Coordinate general engineering support

MOS PERFORMING: 0491, 1371, 3043, 3537

BILLETS: Logistics Chief, Operations Chief, Plans Chief

GRADES: GYSGT, MSGT, MGYSGT

INITIAL TRAINING SETTING: FORMAL

CONDITION: Given higher's operations order, commander's guidance, resources, while operating in a joint, coalition, inter-agency environment, as part of a MAGTF, provided with supported unit requirements and given priorities of engineer effort.

STANDARD: To properly task and resource engineers to establish the infrastructure necessary to conduct and sustain MAGTF operations.

PERFORMANCE STEPS:

1. Identify engineer mission requirements.
2. Identify organic/non-organic general engineering capabilities.
3. Identify MAGTF engineer command and support relationships.
4. Identify employment considerations for general engineering.
5. Identify the prioritized engineer project list process.
6. Coordinate engineer shortfalls (TO&E).
7. Manage CL IV materials.
8. Support the integration of engineer planning products into the Marine Corps Planning Process (MCPPE).
9. Integrate engineer information into appropriate C2 systems and collaborative tools within the COC.

0491-GEN-2002: Perform the general duties of an LCE operations chief

MOS PERFORMING: 0491, 1371, 3043, 3537

BILLETS: Logistics Chief, Operations Chief, Plans Chief

GRADES: GYSGT, MSGT, MGYSGT

INITIAL TRAINING SETTING: FORMAL

CONDITION: Given the commander's guidance, mission, and resources.

STANDARD: To provide oversight on the functional areas of logistics.

PERFORMANCE STEPS:

1. Manage a combat operations center (COC).
2. Establish a combat operations center (COC).
3. Supervise the security and organization of the combat operations Center (COC).
4. Monitor communications with higher, adjacent, supported and supporting units.
5. Enforce battle rhythm.
6. Train the watch section personnel.
7. Produce products in support of the operations section.
8. Execute forward, main and rear CP capabilities/requirements.
9. Establish forward, main and rear CP.
10. Supervise transition control of operations to forward, main or rear combat operations Center (COC) as required.
11. Supervise in-transit visibility asset tracking.
12. Supervise total asset visibility.
13. Employ Automated Information Systems (AIS) to Support Deployment and Distribution Planning.
14. Organize C2 and log AIS.
15. Supervise the use of C2 and log AIS.
16. Monitor common operational picture (COP) of logistics support utilizing C2 systems and AIS.
17. Coordinate cross boundary movement.
18. Monitor convoy operations.
19. Manage unit movement coordination center (UMCC) operations.
20. Coordinate aviation integration.
21. Assist in the Marine Corps Planning Process (MCPPE).
22. Determine logistics capabilities in joint, interagency, NGO, multinational and coalition environment.
23. Determine MAGTF logistics capabilities.
24. Incorporate Naval Logistics Integration into planning.
25. Understand Defense Logistics Agency capabilities.
26. Plan Battlefield Distribution Operations.
27. Plan combat service support operations across the range of military operations.
28. Plan logistics to support civil military operations.

29. Plan logistics to support HADR operations.
30. Plan logistics to support peacekeeping operations.
31. Plan logistics to support defense support to civilian authorities.
32. Plan Support for Maritime Positioning Forces (MPF) Operations.
33. Identify cultural/regional effects on CSS operations.
34. Coordinate non-organic support requirements.
35. Monitor contracting requirements.
36. Understand the limitations/capabilities of a contingency contracting officer.
37. Coordinate force deployment planning and execution (FDP&E).
38. Coordinate reception staging onward movement and integration (RSO&I).
39. Coordinate reconstitution.

0491-HSS-2003: Coordinate health services support

MOS PERFORMING: 0491, 1371, 3043, 3537

BILLETS: Logistics Chief, Operations Chief, Plans Chief

GRADES: GYSGT, MSGT, MGYSGT

INITIAL TRAINING SETTING: FORMAL

CONDITION: Given the operation order, commander's guidance, resources, and the requirement to support a MAGTF.

STANDARD: To ensure health services support, when integrated with the other functional areas of logistics, satisfies the unit's mission.

PERFORMANCE STEPS:

1. Identify health services support requirements.
2. Identify organic/non-organic health services support capabilities.
3. Coordinate health services support.
4. Identify casualty evacuation procedures.
5. Coordinate special programs.
6. Incorporate the appropriate level of care into the health service support plan.
7. Integrate health service support throughout the range of military operations.

0491-MNT-2004: Coordinate maintenance support

MOS PERFORMING: 0491, 1371, 3043, 3537

BILLETS: Logistics Chief, Operations Chief, Plans Chief

GRADES: GYSGT, MSGT, MGYSGT

INITIAL TRAINING SETTING: FORMAL

CONDITION: Given the operation order, commander's guidance, resources, and the requirement to support a MAGTF.

STANDARD: To ensure maintenance support, when integrated with the other functional areas of logistics, satisfies the unit's mission.

PERFORMANCE STEPS:

1. Identify maintenance requirements.
2. Identify maintenance capabilities.
3. Organize maintenance support to sustain scheme of maneuver.
4. Manage maintenance actions.
5. Monitor equipment readiness.
6. Monitor equipment reporting.
7. Coordinate intermediate maintenance support.
8. Identify field service representative capabilities/requirements.
9. Coordinate vehicle recovery operations.
10. Coordinate principal end item (PEI) rotation plan.

0491-OPS-2005: Coordinate amphibious operations

MOS PERFORMING: 0491, 1371, 3043, 3537

BILLETS: Logistics Chief, Operations Chief, Plans Chief

GRADES: GYSGT, MSGT, MGYSGT

INITIAL TRAINING SETTING: FORMAL

CONDITION: Given personnel, the commander's guidance, mission, resources an amphibious operation, operations order, and landing plan.

STANDARD: To support MAGTF amphibious operations in accordance with the landing plan and concept of operations.

PERFORMANCE STEPS:

1. Identify the concept of amphibious operations.
2. Participate in the planning process for amphibious operations.

3. Manage required planning documentation.
4. Supervise embarkation responsibilities.
5. Monitor command and control for amphibious operations.
6. Support the landing plan.
7. Supervise a TACLOG.
8. Organize C4I for amphibious operations.
9. Determine logistics planning considerations.
10. Monitor CSS requests for ship-to-shore movement.
11. Coordinate ship-to-shore movement.
12. Determine ship-to-shore sustainment movement control requirements.
13. Monitor ship-to-shore movement.
14. Monitor the requested support movement ashore.

0491-OPS-2006: Manage unit training

MOS PERFORMING: 0491, 1371, 3043, 3537

BILLETS: Logistics Chief, Operations Chief, Plans Chief

GRADES: GYSGT, MSGT, MGYSGT

INITIAL TRAINING SETTING: FORMAL

CONDITION: Given a unit, commander's guidance, METL, T&R Manuals, required external support and equipment, and references.

STANDARD: To ensure units are prepared to deploy globally in support of combatant commanders requirements.

PERFORMANCE STEPS:

1. Analyze Higher Headquarters' Mission Essential Task List (METL) in order to determine subordinate units' tasks.
2. Derive tasks from higher headquarters' Mission Essential Task List and translate into subordinate units' METs.
3. Identify core METs from associated T&R Manuals.
4. Develop training that supports subordinate units' METs.
5. Determine and procure requirements that support the training plan.
6. Use developed METs to determine the training tasks.
7. Identify and request the required resources.
8. Prepare a training concept.
9. Supervise the training objectives.
10. Review lessons learned/after action reports.
11. Integrate logistical support and C2 into training plan.
12. Incorporate ORM into the training plan.
13. Conduct the instruction.
14. Prepare combat standard operating procedures.
15. Prepare and prioritize mission specific requirements.
16. Create a battalion/regimental pre-deployment training plan.
17. Execute training, evaluation, and remediation.
18. Evaluate training in accordance with appropriate T&R manual.
19. Plan for remediation as required.
20. Update individual training records.
21. Provide inputs and oversight of the DRRS report.
22. Develop and implement validation of combat standard operation procedures.
23. Supervise the remediation plans.
24. Produce lessons learned/after action report.

0491-OPS-2007: Coordinate a unit move

MOS PERFORMING: 0491, 1371, 3043, 3537

BILLETS: Logistics Chief, Operations Chief, Plans Chief

GRADES: GYSGT, MSGT, MGYSGT

INITIAL TRAINING SETTING: FORMAL

CONDITION: Given a requirement to deploy across the range of military operations (ROMO).

STANDARD: To ensure units arrive mission capable in an area of operations.

PERFORMANCE STEPS:

1. Conduct movement training for unit personnel.
2. Train/certify personnel for the submission of AIS products.
3. Review the ConOps of the OpOrd to determine support requirement.
4. Support development of the embarkation plan.

5. Determine lift requirements.
6. Execute the embarkation plan.
7. Coordinate reception staging onward movement and integration (RSO&I).
8. Ensure equipment and cargo is prepared/certified for embarkation.
9. Coordinate with movement control organizations.
10. Supervise the submission of transportation requirements to higher headquarters.
11. Supervise the submission of AIS data.
12. Track INTRA/INTER theater movement.
13. Disseminate a movement schedule to the appropriate units.
14. Conduct the movement.

0491-OPS-2008: Participate in the Marine Corps Planning Process (MCP)

MOS PERFORMING: 0491, 1371, 3043, 3537

BILLETS: Logistics Chief, Operations Chief, Plans Chief

GRADES: GYSGT, MSGT, MGYSGT

INITIAL TRAINING SETTING: FORMAL

CONDITION: Given the operation order, commander's guidance, resources, and the requirement to support a MAGTF.

STANDARD: By producing plans and orders which support the accomplishment of the mission and commander's intent.

PERFORMANCE STEPS:

1. Conduct problem framing.
2. Develop courses of action.
3. Wargame courses of action.
4. Compare and recommend courses of action.
5. Develop orders.
6. Execute transition.

0491-SUP-2009: Coordinate supply support

MOS PERFORMING: 0491, 1371, 3043, 3537

BILLETS: Logistics Chief, Operations Chief, Plans Chief

GRADES: GYSGT, MSGT, MGYSGT

INITIAL TRAINING SETTING: FORMAL

CONDITION: Given a requirement, personnel, and equipment.

STANDARD: To ensure supply support, when integrated with the other functional areas of logistics, satisfies the unit's mission.

PERFORMANCE STEPS:

1. Identify requirements.
2. Identify organic/non-organic supply support capabilities/limitations.
3. Manage an operational deployment block in support of MAGTF operations.
4. Plan initial and sustainment supply requirements.
5. Facilitate MAGTF Distribution Management Operations (DMO).
6. Identify organic distribution capabilities/limitations.
7. Manage reporting requirements.
8. Monitor MAGTF equipment accountability.
9. Monitor a unit's budget.
10. Determine contracting support requirements.
11. Support planning for aviation peculiar ground logistics supply support.

0491-SVC-2010: Coordinate services support

MOS PERFORMING: 0491, 1371, 3043, 3537

BILLETS: Logistics Chief, Operations Chief, Plans Chief

GRADES: GYSGT, MSGT, MGYSGT

INITIAL TRAINING SETTING: FORMAL

CONDITION: Given the operation order, commander's guidance, resources, and the requirement to support a MAGTF.

STANDARD: To ensure services support, when integrated with the other functional areas of logistics, satisfies the unit's mission.

PERFORMANCE STEPS:

1. Identify combat service support services capabilities.
2. Identify command services capabilities.
3. Identify the requirement for combat service support services.
4. Identify the requirement for command services.

5. Coordinate/plan the employment of combat service support services.

0491-TRAN-2011: Coordinate transportation support

MOS PERFORMING: 0491, 1371, 3043, 3537

BILLETS: Logistics Chief, Operations Chief, Plans Chief

GRADES: GYSGT, MSGT, MGYSGT

INITIAL TRAINING SETTING: FORMAL

CONDITION: Given the operation order, commander's guidance, resources, and the requirement to support a MAGTF.

STANDARD: To ensure transportation support, when integrated with the other functional areas of logistics, satisfies the unit's mission.

PERFORMANCE STEPS:

1. Identify transportation requirements.
2. Identify organic/non-organic transportation capabilities.
3. Coordinate force deployment planning and execution (FDP&E).
4. Monitor Time phase force deployment data (TPFDD) products.
5. Coordinate movement planning.
6. Coordinate with movement control agencies.
7. Coordinate landing force support party (LFSP) operations.
8. Coordinate landing support operations.
9. Coordinate air delivery operations.
10. Coordinate helicopter support operations.
11. Coordinate beach operations.
12. Coordinate port operations.
13. Coordinate rail head operations.
14. Coordinate arrival/departure airfield control group operation.
15. Plan/coordinate convoy operations.
16. Direct motor transport operations.
17. Coordinate MHE support operations.

APPENDIX I - 0430 MOS DESCRIPTION

MOS 0430, Mobility Officer (II/III) (LtCol to Capt) and (CW05 to WO) PMOS

a. Summary. Mobility officers plan and execute unit movements of personnel, supplies, and equipment via all modes of transportation. They prepare and execute deployment plans to deploy and sustain Marine combat forces of a MAGTF, joint task, or as a member of a component command. They serve as mobility officers at the regiment, aircraft group, separate battalion, MEU, MarDiv, MAW, and MLG Level; MWSS, CLB, Aircraft Group, and as a Strategic Mobility Officer at the Combatant Command, Joint Task Force, MEF, and MARFOR levels. They also serve as Combat Cargo Officers (CCOs) on naval staffs and amphibious ships. Moreover, they coordinate and conduct unit-level embarkation and mobility training, and they are assigned as Embarkation and Strategic Mobility Instructors at Logistics Operations School, Marine Corps Combat Service Support Schools (MCCSSS) and Expeditionary Warfare Training Group Pacific (ETWGPAC). Mobility officers analyze, translate, and execute commander's operational requirements and intent to support mission requirements. As subject matter experts (SME), they provide interface and articulate the strategic mobility requirements both present and future to appropriate agencies, such as, Headquarters Marine Corps, U.S. Transportation Command and her three Transportation Component Commands (TCCs); Surface Deployment Distribution Command, Military Sealift Command, and Air Mobility Command. This MOS is technical in nature and requires years of training, education, and experience to become proficient. Officers with a primary MOS of 0402 will not be assigned MOS 0430 as an additional MOS.

b. Prerequisites

- (1) Must be a U.S. Citizen.
- (2) Security Requirement: Secret security clearance eligibility.

c. Requirements

- (1) Complete the Mobility Officer Course, Logistics Operations School, Marine Corps Combat Service Support Schools, Camp Johnson/Camp Lejeune, NC (unless completed previously).
- (2) Skill progression schools/courses available to and required (as indicated) for mobility officers include:
 - (a) Transportation of Hazardous Material Course, Navy Supply Corps School, Athens, GA (this course, (b), or (c) is recommended).
 - (b) Intermodal Dry Container Reinspection Course, McAlester, OK.
 - (c) AMC Affiliation Training for Equipment Preparation and Air Load Certification, taught by a Mobile Training Team (EWTGPAC), NAB Coronado, San Diego, CA (required every two years).
 - (d) Ship Loading and Stowage Course, U.S. Army Transportation School, Ft Eustis, VA.
 - (e) Advanced Air Mobility Operations Course, McGuire AFB, NJ (recommended).
 - (f) Maritime Prepositioned Force (MPF) Staff Planning Course, ETWGPAC, NAB Coronado, San Diego, CA, and ETWGLANT, NAB Little Creek, VA.
 - (g) Joint Planning Orientation Course (JPOC), taught at various locations. Quota control is HQMC (Code POC-30) at DSN 224-2116.
 - (h) Joint Operation Planning and Execution System (JOPES), taught at various locations (nine days). Quota Control is HQMC (code POC-3D) at DSN 224-2116.
 - (i) Unit Movement Officer Deployment Planning Course.
 - (j) Military Standard Transportation and Movement Procedures (MILSTAMP) Over, Short, and Damage Procedures, U.S. Army Transportation School, Ft Eustis, VA.
 - (k) Advanced Logistics Officer's Course (ALOC), Marine Corps Combat Development Command, Quantico, VA.
 - (l) Tactical Logistics Operations Course, Marine Corps Combat Development Command, Quantico, VA.
 - (m) Amphibious Ship Load Planners Course, Camp Johnson/Camp Lejeune, NC.

APPENDIX I - 0430 MOS DESCRIPTION

(n) Strategic Deployment Planning Course, Army Logistics University, Ft Lee, VA.

(o) Air Deployment Planning, Transportation School, Ft Lee, VA.

d. Duties. For a complete listing of duties and tasks, refer to reference (h), Logistics Training and Readiness Manual.

e. Related SOC Classification/SOC Code. Transportation, Storage, and Distribution Managers 11-3071.

f. Related Military Skill. None.

APPENDIX J - 0430 T&R PERFORMANCE EVENTS

0430-CCO-2101: Perform Combat Cargo Officer duties

MOS PERFORMING: 0430

BILLETS: Combat Cargo Officer

GRADES: WO, CWO2, CWO3, CWO4

INITIAL TRAINING SETTING: FORMAL

CONDITION: Given a requirement, personnel, and equipment

STANDARD: IAW MCRP 4-11_ Combat Cargo Handbook

PERFORMANCE STEPS:

1. Advise the ships commanding officer on loading plans for the landing force.
2. Maintain Ship Loading Characteristics Pamphlet (SLCP).
3. Assist in the preparation and distribution of Embarked Troop Regulations.
4. Create LFORM supplement.
5. Ensure habitability of landing force spaces.
6. Review and validate ship alterations (SHIPALTS) to landing force spaces.
7. Maintain liaison with the landing force.
8. Staff load plan documentation.
9. Coordinate the support of landing force requirements.
10. Coordinate Ships Platoon integration.
11. Supervise Combat Cargo Platoon.
12. Coordinate the loading/offloading.
13. Support ship-to-shore movement of the landing force.
14. Prepare amphibious documentation.

0430-CCO-2902: Perform Staff Combat Cargo Officer duties

MOS PERFORMING: 0430

BILLETS: Staff Combat Cargo Officer

GRADES: CAPT, MAJ, LTCOL

INITIAL TRAINING SETTING: MOJT

CONDITION: Given a requirement, personnel, cargo and equipment.

STANDARD: IAW MCRP 4-11_ Combat Cargo Handbook.

PERFORMANCE STEPS:

1. Advise the naval commander on load plans for the landing force.
2. Maintain Ship Loading Characteristics Pamphlet (SLCP).
3. Assist in the preparation and distribution of Embarked Troop Regulations.
4. Monitor LFORM program.
5. Ensure habitability of landing force spaces.
6. Review and validate ship alterations (SHIPALTS) to landing force spaces.
7. Maintain liaison with the landing force.
8. Staff load plan documentation.
9. Coordinate the support of landing force requirements.
10. Coordinate Ships Platoon integration.
11. Facilitate Combat Cargo Platoon training.
12. Coordinate the loading/offloading.
13. Support ship-to-shore movement of the landing force.
14. Prepare amphibious documentation.
15. Coordinate opportune lift requirements.

0430-EXCU-2101: Supervise asset tracking functions

MOS PERFORMING: 0430

GRADES: WO, CWO2, CWO3, CWO4, CWO5, CAPT, MAJ, LTCOL

INITIAL TRAINING SETTING: FORMAL

CONDITION: Given deployment data, mode & source, and AIS.

STANDARD: To ensure compliance with DOD asset tracking policies.

PERFORMANCE STEPS:

1. Implement unit asset tracking requirements.
2. Validate unit data for AIS interface.
3. Ensure supplies & equipment are prepared for movement operations.
4. Verify upload of unit data into DOD ITV systems.
5. Track unit equipment and cargo locations using AIT.
6. Validate asset tracking.
7. Generate reports.

0430-EXCU-2102: Coordinate amphibious embarkation and debarkation

MOS PERFORMING: 0430
BILLETS: Embarkation Officer, Team Embarkation Officer
GRADES: WO, CWO2, CWO3, CAPT
INITIAL TRAINING SETTING: FORMAL
CONDITION: Given concept of operations, supplies and equip, and references
STANDARD: Supporting landing plan/offload sequence requirement(s)
PERFORMANCE STEPS:
1. Review the OE&AS.
2. Review the landing plan.
3. Review the SLCP.
4. Validate deployment data for landing force assets.
5. Complete the ship load plan.
6. Reconcile the load plan.
7. Ensure landing force equipment is prepared for embarkation.
8. Review amphibious on load/offload documentation.
9. Ensure landing force assets are staged for embarkation.
10. Identify requirements ISO embarkation.
11. Report the status of embarkation.
12. Reconcile load plan upon completion of ship load.
13. Submit landing force data to the ships Combat Cargo Officer for completion of the Embarked Personnel and Materials Report.

0430-EXCU-2103: Coordinate unit movement

MOS PERFORMING: 0430
GRADES: WO, CWO2, CWO3, CAPT
INITIAL TRAINING SETTING: FORMAL
CONDITION: Given concept of operations, personnel, supplies and equipment, unit move
AIS data, and references.
STANDARD: To meet mission requirement(s).
PERFORMANCE STEPS:
1. Verify movement AIS data.
2. Establish unit movement support requirements.
3. Coordinate required support with unit move agencies.
4. Promulgate movement timeline.

0430-EXCU-2104: Supervise the preparation of supplies and equipment

MOS PERFORMING: 0430
GRADES: WO, CWO2, CWO3, CAPT
INITIAL TRAINING SETTING: FORMAL
CONDITION: Given personnel, supplies and equipment to be embarked, necessary tools,
equipment, references, and assignment to conveyance.
STANDARD: To meet unit move requirements in accordance with conveyance restraints.
PERFORMANCE STEPS:
1. Verify unit move AIS data.
2. Supervise pre-deployment inspections at UMA.
3. Ensure certification of hazardous material for shipment.
4. Supervise staging of supplies and equipment.
5. Ensure adherence to ITV policies.

0430-EXCU-2105: Support ship-to-shore movement

MOS PERFORMING: 0430
GRADES: WO, CWO2, CWO3, CWO4, CAPT
INITIAL TRAINING SETTING: FORMAL
CONDITION: Given a requirement, an amphibious operations order, and landing plan.
STANDARD: IAW MCWP 3-31.5 Ship-to-Shore Movement.
PERFORMANCE STEPS:
1. Coordinate with movement control organizations.
2. Monitor communications to track the execution of the offload.
3. Coordinate transportation for assets with appropriate ship-to-shore movement
coordination agency.
4. Support the landing rehearsal.

0430-EXCU-2206: Supervise shipment of hazardous materials

MOS PERFORMING: 0430
GRADES: WO, CWO2, CWO3, CWO4, CAPT
INITIAL TRAINING SETTING: FORMAL
CONDITION: Given certified personnel, cargo/equipment containing hazardous material, required forms, and references.
STANDARD: To meet certification requirements.
PERFORMANCE STEPS:
1. Identify certification requirements.
2. Verify hazardous cargo has been properly packaged and marked.
3. Verify documentation.
4. Ensure hazardous cargo is properly separated and segregated.
5. Ensure proper care in handling hazardous cargo.

0430-EXCU-2207: Support commercial ship loading operations

MOS PERFORMING: 0430
GRADES: WO, CWO2, CWO3, CWO4, CAPT
INITIAL TRAINING SETTING: FORMAL
CONDITION: Given a commercial ship, supplies and equipment to be loaded, unit move data, and AIS.
STANDARD: To support embarked asset movement requirements in accordance with the Time Phased Force Deployment Data (TPFDD).
PERFORMANCE STEPS:
1. Prepare commercial ship documentation, as required.
2. Ensure preparation of supplies & equipment for commercial ship loading.
3. Coordinate vessel loading.
4. Assist in the preparation of ship loading reports.

0430-EXCU-2908: Supervise unit air embarkation

MOS PERFORMING: 0430
GRADES: WO, CWO2, CWO3, CAPT
INITIAL TRAINING SETTING: MOJT
CONDITION: Given an operation order, deployment information, aircraft allocation, and equipment to deploy.
STANDARD: IAW Defense Travel Regulations (DTR) Volume III.
PERFORMANCE STEPS:
1. Submit initial aircraft load plan.
2. Submit Hazardous Material Diplomatic Clearance (HAZDIP), as required.
3. Validate aircraft allocation.
4. Validate TCNs are assigned.
5. Validate air transportability certification.
6. Supervise staging at unit marshalling area (UMA).
7. Coordinate movement to APOE.
8. Coordinate inspections.
9. Provide certified aircraft load plan.
10. Ensure the designated agency provides passengers manifests.
11. Track unit mission status.

0430-LOGR-2101: Manage unit embarkation inspection program

MOS PERFORMING: 0430
GRADES: WO, CWO2, CWO3, CWO4, CWO5, CAPT, MAJ, LTCOL
INITIAL TRAINING SETTING: FORMAL
CONDITION: Given AIS data, personnel and equipment, unit to be inspected, and references.
STANDARD: IAW MCRP 4-11.3_ Unit Embarkation Handbook.
PERFORMANCE STEPS:
1. Establish inspection schedule.
2. Validate unit personnel training report.
3. Validate AIS data.
4. Supervise inspections.
5. Report inspection results.
6. Ensure corrective action taken.

0430-LOGR-2102: Manage unit embarkation training program

MOS PERFORMING: 0430

GRADES: WO, CWO2, CWO3, CWO4, CWO5, CAPT, MAJ, LTCOL

INITIAL TRAINING SETTING: FORMAL

CONDITION: Given inspection results, personnel and equipment, formal schools training schedule, and references.

STANDARD: In accordance with Unit Training Manual.

PERFORMANCE STEPS:

1. Identify training deficiencies.
2. Validate embarkation unit personnel training report.
3. Establish training requirements.
4. Establish annual training plan.
5. Ensure conduct of MOS Training as prescribed by NAVMC 3500.27_.

0430-LOGR-2903: Perform Strategic Mobility Officer duties

MOS PERFORMING: 0430

GRADES: CWO5, CAPT, MAJ, LTCOL

INITIAL TRAINING SETTING: MOJT

CONDITION: When assigned to the service headquarters, a component, MARFOR, or MEF staff, and given requirements and references.

STANDARD: IAW MCRP 4-11.3_ Unit Embarkation Handbook.

PERFORMANCE STEPS:

1. Prepare strategic mobility plans.
2. Execute strategic mobility plans.
3. Articulate MAGTFs mobility needs to higher headquarters, unified and specified commanders, and the transportation component command.
4. Publish strategic airlift/sealift policy.
5. Manage 463L pallet system war reserves.
6. Manage occupational field personnel.
7. Assist the MAGTF Deployment Distribution Officer.
8. Manage the occupational field standardization.

0430-LOGR-2904: Manage transportation budget

MOS PERFORMING: 0430

GRADES: CWO3, CWO4, CWO5, CAPT, MAJ, LTCOL

INITIAL TRAINING SETTING: MOJT

CONDITION: Given a Training Exercise Employment Plan (TEEP), transportation rate tables, historical data, comptroller guidance, long range forecast, deployment data, AIS, and references.

STANDARD: IAW MCO P7100.8_.

PERFORMANCE STEPS:

1. Review TEEP.
2. Publish planning factors.
3. Consolidate annual transportation budget inputs.
4. Generate transportation budget estimate.
5. Maintain fiscal ledgers.
6. Brief deficiencies to G-3/Comptroller.
7. Consolidate monthly transportation budget adjustments.
8. Make transportation budget recommendations.
9. Validate liquidation reports against expended funds.

0430-PLAN-2101: Support deployment planning

MOS PERFORMING: 0430

GRADES: WO, CWO2, CWO3, CWO4, CWO5, CAPT, MAJ, LTCOL

INITIAL TRAINING SETTING: FORMAL

CONDITION: Given concept of operation, planning guidance, force requirements, AIS, and references

STANDARD: To ensure that associated deployment plans support the concept of operation

PERFORMANCE STEPS:

1. Participate in the Marine Corps Planning Process.
2. Provide input for mission budget.
3. Develop an embarkation LOI.
4. Identify transportation requirements.

0430-PLAN-2102: Manage unit move AIS data

MOS PERFORMING: 0430

BILLETS: Embarkation Officer

GRADES: WO, CWO2, CWO3, CAPT

INITIAL TRAINING SETTING: FORMAL

CONDITION: Given AIS, supplies and equipment, and references.

STANDARD: To ensure all unit move requirements are identified in unit move AIS.

PERFORMANCE STEPS:

1. Supervise unit move AIS.
2. Validate MDL update completion.
3. Supervise garrison database management.
4. Supervise load plan AIS.
5. Ensure adherence to ITV policies.

0430-PLAN-2103: Determine cost feasibility for transportation

MOS PERFORMING: 0430

BILLETS: Embarkation Officer

GRADES: WO, CWO2, CWO3, CWO4, CWO5, CAPT, MAJ, LTCOL

INITIAL TRAINING SETTING: FORMAL

CONDITION: Given a concept of operations, deployment data, AIS, and references.

STANDARD: To ensure all costs are estimated, per the references.

PERFORMANCE STEPS:

1. Determine the number and type of transportation assets required.
2. Determine the applicable cost rate tables.
3. Calculate the estimated cost for movement of personnel, supplies, cargo, and equipment for each type of conveyance required.
4. Calculate the total transportation cost.
5. Compare total transportation cost estimate to annual budget.
6. Report budget deficiencies/feasibility.
7. Maintain transportation budget.

0430-PLAN-2104: Supervise sourcing of force requirements

MOS PERFORMING: 0430

GRADES: WO, CWO2, CWO3, CAPT

INITIAL TRAINING SETTING: FORMAL

CONDITION: Given planning guidance, force requirements, and unit move AIS.

STANDARD: To ensure all force requirements are registered in Joint Operation Planning and Execution Systems (JOPEs).

PERFORMANCE STEPS:

1. Ensure consolidation of unit/MAGTF data.
2. Ensure receipt of force requirements via AIS.
3. Ensure sourcing of force requirements using AIS.
4. Ensure submission of sourced force requirements via AIS.
5. Validate force requirements using AIS reports.

0430-PLAN-2105: Prepare an airlift request

MOS PERFORMING: 0430

GRADES: WO, CWO2, CWO3, CAPT

INITIAL TRAINING SETTING: FORMAL

CONDITION: Given a concept of operations, unit embarkation data, and automated information systems (AIS).

STANDARD: IAW Defense Transportation Regulation Parts I & II.

PERFORMANCE STEPS:

1. Validate the requirement.
2. Complete the request.
3. Submit airlift request.
4. Monitor the status of the request(s).

0430-PLAN-2106: Prepare an embarkation plan

MOS PERFORMING: 0430

GRADES: WO, CWO2, CWO3, CAPT

INITIAL TRAINING SETTING: FORMAL

CONDITION: Given AIS report(s) and deployment schedule(s).

STANDARD: Supporting unit move requirement(s).

PERFORMANCE STEPS:

1. Verify assets to be embarked.
2. Determine special handling requirements.
3. Verify passenger requirements.
4. Identify marshalling and staging areas.
5. Identify ports of embarkation/debarkation (POE/POD).
6. Publish embarkation schedules.
7. Identify communications requirements.
8. Prepare and distribute required reports.

0430-PLAN-2207: Validate an amphibious ship load plan

MOS PERFORMING: 0430

GRADES: WO, CWO2, CWO3, CWO4, CWO5, CAPT, MAJ

INITIAL TRAINING SETTING: FORMAL

CONDITION: Given conveyance information, unit embarkation data, load plan, and automated information systems (AIS).

STANDARD: To meet all moving unit lift requirements.

PERFORMANCE STEPS:

1. Review conveyance characteristics.
2. Review unit lift requirements.
3. Identify corrective actions, as required.
4. Submit documentation.

0430-PLAN-2208: Validate an aircraft load plan

MOS PERFORMING: 0430

GRADES: WO, CWO2, CWO3, CWO4, CWO5, CAPT, MAJ

INITIAL TRAINING SETTING: FORMAL

CONDITION: Given conveyance information, unit embarkation data, load plan, and automated information systems (AIS).

STANDARD: To meet all moving unit lift requirements.

PERFORMANCE STEPS:

1. Review conveyance characteristics.
2. Review unit lift requirements.
3. Identify corrective actions, as required.
4. Submit documentation.

0430-PLAN-2209: Validate a rail load plan

MOS PERFORMING: 0430

GRADES: WO, CWO2, CWO3, CWO4, CWO5, CAPT, MAJ

INITIAL TRAINING SETTING: FORMAL

CONDITION: Given conveyance information, unit embarkation data, load plan, and automated information systems (AIS).

STANDARD: To meet all moving unit lift requirements.

PERFORMANCE STEPS:

1. Review conveyance characteristics.
2. Review unit lift requirements.
3. Identify corrective actions, as required.
4. Submit documentation.

0430-PLAN-2210: Validate a commercial ship load plan

MOS PERFORMING: 0430

GRADES: WO, CWO2, CWO3, CWO4, CWO5, CAPT, MAJ

INITIAL TRAINING SETTING: FORMAL

CONDITION: Given conveyance information, unit embarkation data, load plan, and automated information systems (AIS).

STANDARD: To meet all moving unit lift requirements.

PERFORMANCE STEPS:

1. Review conveyance characteristics.
2. Review unit lift requirements.
3. Identify corrective actions, as required.
4. Submit documentation.

0430-PLAN-2211: Validate a commercial truck load plan

MOS PERFORMING: 0430

GRADES: WO, CWO2, CWO3, CWO4, CWO5, CAPT, MAJ

INITIAL TRAINING SETTING: FORMAL

CONDITION: Given conveyance information, unit embarkation data, load plan, and automated information systems (AIS).

STANDARD: To meet all moving unit lift requirements.

PERFORMANCE STEPS:

1. Review conveyance characteristics.
2. Review unit lift requirements.
3. Identify corrective actions, as required.
4. Submit documentation.

APPENDIX K - Educational Level

YEAR	RANK		MOS	SEL	MA>	BA	AA	HSE	% HSE
2005-11	LTCOL	LDO	ALL	86	7	28	8	43	50.00%
2005-11	LTCOL	LDO	0210	1	0	0	0	1	100.00%
2005-11	LTCOL	LDO	0430	15	2	3	2	8	53.33%
2005-11	LTCOL	LDO	0650	1	0	1	0	0	0.00%
2005-11	LTCOL	LDO	2102	8	0	0	0	8	100.00%
2005-11	LTCOL	LDO	2305	8	0	3	0	5	62.50%
2005-11	LTCOL	LDO	2340	9	0	4	0	5	55.56%
2005-11	LTCOL	LDO	2802	6	0	2	2	2	33.33%
2005-11	LTCOL	LDO	3102	4	0	2	0	2	50.00%
2005-11	LTCOL	LDO	3302	4	1	2	0	1	25.00%
2005-11	LTCOL	LDO	5902	5	1	2	1	1	20.00%
2005-11	LTCOL	LDO	6004	10	0	3	1	6	60.00%
2005-11	LTCOL	LDO	6302	7	1	3	1	2	28.57%
2005-11	LTCOL	LDO	6502	7	2	2	1	2	28.57%
2005-11	LTCOL	LDO	6802	1	0	1	0	0	0.00%

YEAR	RANK		MOS	SEL	MA>	BA	AA	HSE	% HSE
2005-11	MAJOR	LDO	ALL	278	16	68	31	163	58.63%
2005-11	MAJOR	LDO	0430	46	1	10	3	32	69.57%
2005-11	MAJOR	LDO	0650	4	1	2	1	0	0.00%
2005-11	MAJOR	LDO	2102	28	0	3	4	21	75.00%
2005-11	MAJOR	LDO	2305	11	0	3	3	5	45.45%
2005-11	MAJOR	LDO	2340	20	0	6	2	12	60.00%
2005-11	MAJOR	LDO	2802	32	3	4	3	22	68.75%
2005-11	MAJOR	LDO	3102	8	1	3	1	3	37.50%
2005-11	MAJOR	LDO	3302	10	2	3	1	4	40.00%
2005-11	MAJOR	LDO	3410	2	1	1	0	0	0.00%
2005-11	MAJOR	LDO	4010	4	0	1	0	3	75.00%
2005-11	MAJOR	LDO	4602	2	0	1	0	1	50.00%
2005-11	MAJOR	LDO	5902	27	3	6	5	13	48.15%
2005-11	MAJOR	LDO	6004	24	2	8	4	10	41.67%
2005-11	MAJOR	LDO	6302	30	1	13	2	14	46.67%
2005-11	MAJOR	LDO	6502	24	1	2	1	20	83.33%
2005-11	MAJOR	LDO	6802	6	0	2	1	3	50.00%

APPENDIX K - Educational Level

YEAR	RANK	MOS	SEL	MA>	BA	AA	HSE	% HSE
2006-10¹	CWO3-5	ALL	1511	50	156	175	1130	74.93%
2006-10	CWO3-5	0160	13	0	1	1	11	84.62%
2006-10	CWO3-5	0170	181	17	30	33	102	56.35%
2006-10	CWO3-5	0210	54	0	1	6	46	85.19%
2006-10	CWO3-5	0306	62	0	1	3	58	93.55%
2006-10	CWO3-5	0430	72	1	2	10	59	81.94%
2006-10	CWO3-5	0610	33	0	1	3	29	87.88%
2006-10	CWO3-5	0620	23	0	2	1	20	86.96%
2006-10	CWO3-5	0640	4	0	0	0	4	100.00%
2006-10	CWO3-5	0650	26	0	3	5	18	69.23%
2006-10	CWO3-5	0803	19	0	0	0	19	100.00%
2006-10	CWO3-5	0930	18	0	1	1	16	88.89%
2006-10	CWO3-5	1120	24	0	4	2	18	75.00%
2006-10	CWO3-5	1310	47	0	3	4	40	85.11%
2006-10	CWO3-5	1390	21	0	4	1	16	76.19%
2006-10	CWO3-5	2110	7	0	0	0	7	100.00%
2006-10	CWO3-5	2120	64	0	6	3	55	85.94%
2006-10	CWO3-5	2125	4	0	1	1	2	50.00%
2006-10	CWO3-5	2305	33	3	1	1	28	84.85%
2006-10	CWO3-5	2340	31	0	1	5	25	80.65%
2006-10	CWO3-5	2602	33	4	2	2	25	75.76%
2006-10	CWO3-5	2805	51	2	5	4	40	78.43%
2006-10	CWO3-5	3010	24	2	3	3	16	66.67%
2006-10	CWO3-5	3102	15	1	4	4	6	40.00%
2006-10	CWO3-5	3302	19	0	1	3	15	78.95%
2006-10	CWO3-5	3402	24	0	4	6	14	58.33%
2006-10	CWO3-5	3408	26	0	10	3	13	50.00%
2006-10	CWO3-5	3410	7	1	6	0	0	0.00%
2006-10	CWO3-5	3510	67	2	3	9	53	79.10%
2006-10	CWO3-5	4130	10	4	0	1	5	50.00%
2006-10	CWO3-5	4430	14	1	6	1	6	42.86%
2006-10	CWO3-5	4602	18	1	1	2	14	77.78%
2006-10	CWO3-5	4810	5	0	0	0	5	100.00%
2006-10	CWO3-5	5502	7	3	2	0	2	28.57%
2006-10	CWO3-5	5702	91	0	7	13	71	78.02%
2006-10	CWO3-5	5804	14	2	3	3	6	42.86%
2006-10	CWO3-5	5805	10	0	3	0	7	70.00%
2006-10	CWO3-5	5910	11	1	0	3	7	63.64%
2006-10	CWO3-5	5950	15	0	2	5	8	53.33%
2006-10	CWO3-5	5970	8	1	0	1	6	75.00%
2006-10	CWO3-5	6004	80	1	6	6	67	83.75%
2006-10	CWO3-5	6302	71	0	12	10	49	69.01%
2006-10	CWO3-5	6502	53	1	1	5	46	86.79%
2006-10	CWO3-5	6604	28	1	3	3	21	75.00%
2006-10	CWO3-5	6802	14	0	3	1	10	71.43%
2006-10	CWO3-5	7002	30	0	6	6	18	60.00%
2006-10	CWO3-5	7380	11	0	0	1	10	90.91%
2006-10	CWO3-5	9805	1	1	0	0	0	0.00%
2006-10	CWO3-5	9815	7	0	1	0	6	85.71%
2006-10	CWO3-5	9925	11	0	0	0	11	100.00%

¹ 2008 CWO5 education data was not available.

APPENDIX K - Educational Level

YEAR	RANK	MOS	SEL	MA>	BA	AA	HSE	% HSE
2006-10²	CWO-5	ALL	110	13	17	13	67	60.91%
2006-10	CWO-5	0170	19	5	2	2	10	52.63%
2006-10	CWO-5	0210	5	0	0	2	3	60.00%
2006-10	CWO-5	0306	6	0	0	1	5	83.33%
2006-10	CWO-5	0430	5	1	1	0	3	60.00%
2006-10	CWO-5	0610	2	0	0	0	2	100.00%
2006-10	CWO-5	0620	2	0	1	0	1	50.00%
2006-10	CWO-5	0650	1				1	100.00%
2006-10	CWO-5	0803	1				1	100.00%
2006-10	CWO-5	0930	2	0	0	0	2	100.00%
2006-10	CWO-5	1120	3	0	1	1	1	33.33%
2006-10	CWO-5	1310	4	0	1	0	3	75.00%
2006-10	CWO-5	1390	1				1	100.00%
2006-10	CWO-5	2120	3	0	0	0	3	100.00%
2006-10	CWO-5	2305	2	2	0	0	0	0.00%
2006-10	CWO-5	2340	1	0	0	0	1	100.00%
2006-10	CWO-5	2602	3	1	0	0	2	66.67%
2006-10	CWO-5	2805	2	1	0	0	1	50.00%
2006-10	CWO-5	3010	2	0	0	0	2	100.00%
2006-10	CWO-5	3302	1	0	0	0	1	100.00%
2006-10	CWO-5	3402	3	0	1	1	1	33.33%
2006-10	CWO-5	3408	2	0	2	0	0	0.00%
2006-10	CWO-5	3510	3	0	0	0	3	100.00%
2006-10	CWO-5	4130	1	1				0.00%
2006-10	CWO-5	4430	1	0	1	0	0	0.00%
2006-10	CWO-5	4602	0	0	0	0	0	#DIV/0!
2006-10	CWO-5	4810	1	0	0	0	1	100.00%
2006-10	CWO-5	5502	1	1				0.00%
2006-10	CWO-5	5702	5	0	0	1	4	80.00%
2006-10	CWO-5	5804	1	0	0	0	1	100.00%
2006-10	CWO-5	5805	2	0	2	0	0	0.00%
2006-10	CWO-5	5910	1	0	0	1	0	0.00%
2006-10	CWO-5	5950	2	0	0	2	0	0.00%
2006-10	CWO-5	5970	1	1			0	0.00%
2006-10	CWO-5	6004	7	0	3	0	4	57.14%
2006-10	CWO-5	6302	7	0	1	0	6	85.71%
2006-10	CWO-5	6502	2	0	0	0	2	100.00%
2006-10	CWO-5	6604	1	0	1	0	0	0.00%
2006-10	CWO-5	7002	2	0	0	2	0	0.00%
2006-10	CWO-5	9815	1	0	0	0	1	100.00%
2006-10	CWO-5	9925	1	0	0	0	1	100.00%

² 2008 CWO5 education data was not available.

APPENDIX K - Educational Level

YEAR	RANK	MOS	SEL	MA>	BA	AA	HSE	% HSE
2006-10	CWO-4	ALL	425	22	62	53	288	67.76%
2006-10	CWO-4	0160	3	0	1	0	2	66.67%
2006-10	CWO-4	0170	61	9	14	13	26	42.62%
2006-10	CWO-4	0210	17	0	0	3	13	76.47%
2006-10	CWO-4	0306	21	0	0	2	19	90.48%
2006-10	CWO-4	0430	15	0	0	2	13	86.67%
2006-10	CWO-4	0610	11	0	0	3	8	72.73%
2006-10	CWO-4	0620	7	0	1	0	6	85.71%
2006-10	CWO-4	0650	6	0	0	1	5	83.33%
2006-10	CWO-4	0803	6	0	0	0	6	100.00%
2006-10	CWO-4	0930	7	0	0	1	6	85.71%
2006-10	CWO-4	1120	7	0	3	1	3	42.86%
2006-10	CWO-4	1310	13	0	1	1	11	84.62%
2006-10	CWO-4	1390	7	0	3	1	3	42.86%
2006-10	CWO-4	2110	7	0	0	0	7	100.00%
2006-10	CWO-4	2120	10	0	4	0	6	60.00%
2006-10	CWO-4	2125	2	0	1	1	0	0.00%
2006-10	CWO-4	2305	2	1	1			0.00%
2006-10	CWO-4	2340	7	0	0	1	6	85.71%
2006-10	CWO-4	2602	9	1	1	0	7	77.78%
2006-10	CWO-4	2805	16	1	5	0	10	62.50%
2006-10	CWO-4	3010	7	2	1	0	4	57.14%
2006-10	CWO-4	3102	2	0	1	0	1	50.00%
2006-10	CWO-4	3302	1	0	1	0	0	0.00%
2006-10	CWO-4	3402	8	0	2	2	4	50.00%
2006-10	CWO-4	3408	6	0	2	0	4	66.67%
2006-10	CWO-4	3410	1		1			0.00%
2006-10	CWO-4	3510	25	1	2	6	16	64.00%
2006-10	CWO-4	4130	3	2	0	0	1	33.33%
2006-10	CWO-4	4430	5	0	2	0	3	60.00%
2006-10	CWO-4	4602	4	0	1	0	3	75.00%
2006-10	CWO-4	4810	1	0	0	0	1	100.00%
2006-10	CWO-4	5502	2	2	0	0	0	0.00%
2006-10	CWO-4	5702	29	0	4	5	20	68.97%
2006-10	CWO-4	5804	4	1	0	2	1	25.00%
2006-10	CWO-4	5805	4	0	1	0	3	75.00%
2006-10	CWO-4	5910	2	0	0	0	2	100.00%
2006-10	CWO-4	5950	2	0	1	0	1	50.00%
2006-10	CWO-4	5970	2	0	0	1	1	50.00%
2006-10	CWO-4	6004	20	1	1	1	17	85.00%
2006-10	CWO-4	6302	20	0	3	1	16	80.00%
2006-10	CWO-4	6502	13	0	0	3	10	76.92%
2006-10	CWO-4	6604	8	0	1	1	6	75.00%
2006-10	CWO-4	6802	3	0	1	0	2	66.67%
2006-10	CWO-4	7002	8	0	1	1	6	75.00%
2006-10	CWO-4	7380	3	0	0	0	3	100.00%
2006-10	CWO-4	9805	1	1				0.00%
2006-10	CWO-4	9815	3	0	1	0	2	66.67%
2006-10	CWO-4	9925	4	0	0	0	4	100.00%

APPENDIX K - Educational Level

YEAR	RANK	MOS	SEL	MA>	BA	AA	HSE	% HSE
2006-10	CWO-3	ALL	976	15	77	109	775	79.41%
2006-10	CWO-3	0160	10	0	0	1	9	90.00%
2006-10	CWO-3	0170	101	3	14	18	66	65.35%
2006-10	CWO-3	0210	32	0	1	1	30	93.75%
2006-10	CWO-3	0306	35	0	1	0	34	97.14%
2006-10	CWO-3	0430	52	0	1	8	43	82.69%
2006-10	CWO-3	0610	20	0	1	0	19	95.00%
2006-10	CWO-3	0620	14	0	0	1	13	92.86%
2006-10	CWO-3	0640	4	0	0	0	4	100.00%
2006-10	CWO-3	0803	12	0	0	0	12	100.00%
2006-10	CWO-3	0930	9	0	1	0	8	88.89%
2006-10	CWO-3	1120	14	0	0	0	14	100.00%
2006-10	CWO-3	1310	30	0	1	3	26	86.67%
2006-10	CWO-3	1390	13	0	1	0	12	92.31%
2006-10	CWO-3	2120	51	0	2	3	46	90.20%
2006-10	CWO-3	2125	2	0	0	0	2	100.00%
2006-10	CWO-3	2305	29	0	0	1	28	96.55%
2006-10	CWO-3	2340	23	0	1	4	18	78.26%
2006-10	CWO-3	2602	21	2	1	2	16	76.19%
2006-10	CWO-3	2805	33	0	0	4	29	87.88%
2006-10	CWO-3	3010	15	0	2	3	10	66.67%
2006-10	CWO-3	3102	13	1	3	4	5	38.46%
2006-10	CWO-3	3302	17	0	0	3	14	82.35%
2006-10	CWO-3	3402	13	0	1	3	9	69.23%
2006-10	CWO-3	3408	18	0	6	3	9	50.00%
2006-10	CWO-3	3410	6	1	5	0	0	0.00%
2006-10	CWO-3	3510	39	1	1	3	34	87.18%
2006-10	CWO-3	4130	6	1	0	1	4	66.67%
2006-10	CWO-3	4430	8	1	3	1	3	37.50%
2006-10	CWO-3	4602	14	1	0	2	11	78.57%
2006-10	CWO-3	4810	3	0	0	0	3	100.00%
2006-10	CWO-3	5502	4	0	2	0	2	50.00%
2006-10	CWO-3	5702	57	0	3	7	47	82.46%
2006-10	CWO-3	5804	9	1	3	1	4	44.44%
2006-10	CWO-3	5805	4	0	0	0	4	100.00%
2006-10	CWO-3	5910	8	1	0	2	5	62.50%
2006-10	CWO-3	5950	11	0	1	3	7	63.64%
2006-10	CWO-3	5970	5	0	0	0	5	100.00%
2006-10	CWO-3	6004	53	0	2	5	46	86.79%
2006-10	CWO-3	6302	44	0	8	9	27	61.36%
2006-10	CWO-3	6500	19	0	3	4	12	63.16%
2006-10	CWO-3	6502	38	1	1	2	34	89.47%
2006-10	CWO-3	6604	19	1	1	2	15	78.95%
2006-10	CWO-3	6802	11	0	2	1	8	72.73%
2006-10	CWO-3	7002	20	0	5	3	12	60.00%
2006-10	CWO-3	7380	8	0	0	1	7	87.50%
2006-10	CWO-3	9815	3	0	0	0	3	100.00%
2006-10	CWO-3	9925	6	0	0	0	6	100.00%

APPENDIX L - WO, CWO & LDO TIG, TIS & AGE

YEAR	RANK	MOS	SEL	AVG TIG	AVG TIS	AVG AGE
2005-11	MAJOR LDO	ALL	278	3.52	22.09	41.70
2005-11	MAJOR LDO	430	46	3.28	19.65	39.43
2005-11	MAJOR LDO	2802	32	4.23	22.49	44.17
2005-11	MAJOR LDO	6302	30	3.88	22.82	42.69
2005-11	MAJOR LDO	2102	28	3.11	21.16	41.00
2005-11	MAJOR LDO	6004	24	4.65	25.59	43.76
2005-11	MAJOR LDO	5902	27	3.12	21.05	40.52
2005-11	MAJOR LDO	6502	24	3.89	22.81	41.53
2005-11	MAJOR LDO	2340	20	3.12	21.34	40.61
2005-11	MAJOR LDO	3302	10	2.57	21.77	41.89
2005-11	MAJOR LDO	6802	6	5.04	24.50	44.36
2005-11	MAJOR LDO	2305	11	2.60	21.90	40.93
2005-11	MAJOR LDO	3102	8	3.40	22.54	42.53
2005-11	MAJOR LDO	650	4	2.73	19.47	39.80
2005-11	MAJOR LDO	3410	2	3.10	20.50	43.85
2005-11	MAJOR LDO	4010	4	3.50	22.00	40.50
2005-11	MAJOR LDO	4602	2	2.60	20.15	38.90
2005-11	LTCOL LDO	ALL	86	4.16	26.76	46.27
2005-11	LTCOL LDO	430	15	4.57	25.73	45.62
2005-11	LTCOL LDO	6004	10	3.6	27.75	47.25
2005-11	LTCOL LDO	2340	9	3.06	25.43	44.99
2005-11	LTCOL LDO	2102	8	4.58	31.96	45.36
2005-11	LTCOL LDO	2305	8	3.72	26.12	45.54
2005-11	LTCOL LDO	6302	7	5.37	26.57	47.21
2005-11	LTCOL LDO	6502	7	5.02	26.05	46.7
2005-11	LTCOL LDO	2802	6	4.65	26.05	47.28
2005-11	LTCOL LDO	5902	5	4.18	25.38	45.38
2005-11	LTCOL LDO	3102	4	3.48	26.88	46.75
2005-11	LTCOL LDO	3302	4	3.55	26.7	47.7
2005-11	LTCOL LDO	6802	1	3.7	29.4	49.2
2005-11	LTCOL LDO	210	1	3.3	26.3	44.6
2005-11	LTCOL LDO	650	1	3.7	25.2	43.1

APPENDIX L - WO, CWO & LDO TIG, TIS & AGE

YEAR	RANK	MOS	SEL	AVG TIG	AVG TIS	AVG AGE
2006-09	CWO3-5	ALL	1208	2.89	19.13	39.16
2006-09	CWO3-5	0160	9	2.88	19.84	39.70
2006-09	CWO3-5	0170	134	3.01	20.33	39.79
2006-09	CWO3-5	0210	40	2.38	18.83	38.45
2006-09	CWO3-5	0306	52	2.49	22.62	42.10
2006-09	CWO3-5	0430	57	2.77	17.49	37.43
2006-09	CWO3-5	0610	24	2.79	17.33	38.42
2006-09	CWO3-5	0640	18	3.36	18.10	37.19
2006-09	CWO3-5	0650	19	2.07	18.27	39.98
2006-09	CWO3-5	0803	14	2.56	19.38	39.08
2006-09	CWO3-5	0930	11	2.95	21.07	40.07
2006-09	CWO3-5	1120	23	3.37	19.83	40.54
2006-09	CWO3-5	1310	35	3.19	18.39	38.24
2006-09	CWO3-5	1390	19	3.53	20.50	40.08
2006-09	CWO3-5	2110	28	3.03	18.49	38.52
2006-09	CWO3-5	2120	32	3.08	19.45	39.89
2006-09	CWO3-5	2125	4	3.17	20.20	41.30
2006-09	CWO3-5	2305	22	2.00	19.20	39.13
2006-09	CWO3-5	2340	27	2.40	18.00	38.13
2006-09	CWO3-5	2602	28	2.56	19.38	38.82
2006-09	CWO3-5	2805	43	2.42	19.10	38.68
2006-09	CWO3-5	3010	21	2.78	20.11	39.27
2006-09	CWO3-5	3102	10	2.70	18.38	37.05
2006-09	CWO3-5	3302	12	2.00	16.40	36.93
2006-09	CWO3-5	3402	21	3.21	18.87	38.87
2006-09	CWO3-5	3408	22	3.02	19.53	40.55
2006-09	CWO3-5	3410	7	2.00	19.37	40.47
2006-09	CWO3-5	3510	61	3.36	19.03	38.62
2006-09	CWO3-5	4130	7	2.25	17.30	38.75
2006-09	CWO3-5	4430	14	3.40	18.28	39.95
2006-09	CWO3-5	4602	15	2.71	16.71	36.07
2006-09	CWO3-5	4810	2	3.50	19.20	38.20
2006-09	CWO3-5	5502	4	3.27	19.77	45.43
2006-09	CWO3-5	5702	74	3.10	18.22	38.24
2006-09	CWO3-5	5804	13	3.63	19.38	39.78
2006-09	CWO3-5	5805	9	2.56	20.44	40.91
2006-09	CWO3-5	5910	10	2.87	19.44	39.24
2006-09	CWO3-5	5950	10	3.00	18.18	38.20
2006-09	CWO3-5	5970	7	2.92	19.96	40.38
2006-09	CWO3-5	6004	68	2.54	18.78	38.54
2006-09	CWO3-5	6302	50	3.36	20.33	39.57
2006-09	CWO3-5	6502	44	2.12	19.78	40.03
2006-09	CWO3-5	6604	23	3.21	19.38	38.99
2006-09	CWO3-5	6802	12	2.67	17.53	38.02
2006-09	CWO3-5	7002	24	2.83	18.15	37.65
2006-09	CWO3-5	7380	10	3.88	18.38	37.96
2006-09	CWO3-5	9805	1	3.00	18.80	44.60
2006-09	CWO3-5	9815	7	2.67	19.00	40.07
2006-09	CWO3-5	9925	11	2.78	20.72	40.86

APPENDIX L - WO, CWO & LDO TIG, TIS & AGE

YEAR	RANK	MOS	SEL	AVG TIG	AVG TIS	AVG AGE
2006-09	CWO-5	ALL	105	2.69	23.24	43.37
2006-09	CWO-5	0160	0			
2006-09	CWO-5	0170	15	2.82	23.26	42.92
2006-09	CWO-5	0205	0			
2006-09	CWO-5	0210	3	2.25	24.10	43.20
2006-09	CWO-5	0306	8	2.35	25.80	45.25
2006-09	CWO-5	0430	4	2.50	22.65	43.20
2006-09	CWO-5	0610	2	3.10	20.15	43.45
2006-09	CWO-5	0640	2	2.00	21.65	40.05
2006-09	CWO-5	0650	1	1.20	22.90	43.20
2006-09	CWO-5	0803	2	2.10	24.40	42.35
2006-09	CWO-5	0930	2	3.15	23.35	42.10
2006-09	CWO-5	1120	3	3.90	23.33	46.30
2006-09	CWO-5	1310	2	2.80	23.80	43.60
2006-09	CWO-5	1390	2	2.45	21.55	41.05
2006-09	CWO-5	2110	2	3.00	22.00	43.15
2006-09	CWO-5	2120	2	3.00	20.40	45.30
2006-09	CWO-5	2125	0			
2006-09	CWO-5	2305	2	2.00	26.00	45.30
2006-09	CWO-5	2340	1	2.60	24.20	49.40
2006-09	CWO-5	2510	0			
2006-09	CWO-5	2602	4	1.73	21.07	39.87
2006-09	CWO-5	2805	2	2.00	22.75	41.65
2006-09	CWO-5	2810	0			
2006-09	CWO-5	3010	2	2.90	23.20	41.50
2006-09	CWO-5	3102	0			
2006-09	CWO-5	3302	0			
2006-09	CWO-5	3402	3	2.60	23.37	42.47
2006-09	CWO-5	3408	3	2.00	21.53	42.50
2006-09	CWO-5	3410	0			
2006-09	CWO-5	3510	5	3.45	25.25	43.80
2006-09	CWO-5	4010	0			
2006-09	CWO-5	4130	0			
2006-09	CWO-5	4430	1	2.70	25.50	44.10
2006-09	CWO-5	4602	0			
2006-09	CWO-5	4810	0			
2006-09	CWO-5	5502	1	1.70	21.60	48.90
2006-09	CWO-5	5702	7	2.78	22.05	44.13
2006-09	CWO-5	5804	1	4.20	22.70	41.50
2006-09	CWO-5	5805	2	2.10	23.20	45.25
2006-09	CWO-5	5910	1	6.10	18.50	42.80
2006-09	CWO-5	5950	1	3.00	27.00	44.90
2006-09	CWO-5	5970	2	2.10	24.70	43.20
2006-09	CWO-5	6004	5	1.83	21.03	40.33
2006-09	CWO-5	6302	4	4.37	26.10	44.43
2006-09	CWO-5	6502	2	2.40	24.85	45.15
2006-09	CWO-5	6604	1	5.00	26.00	44.70
2006-09	CWO-5	6802	1	3.00	21.40	42.50
2006-09	CWO-5	7002	2	2.80	22.20	41.35
2006-09	CWO-5	7380	0			
2006-09	CWO-5	9805	0			
2006-09	CWO-5	9815	1	2.50	26.60	45.70
2006-09	CWO-5	9925	1	1.70	27.10	48.30

APPENDIX L - WO, CWO & LDO TIG, TIS & AGE

YEAR	RANK	MOS	SEL	AVG TIG	AVG TIS	AVG AGE
2006-09	CWO-4	ALL	334	2.91	20.26	40.37
2006-09	CWO-4	0160	2	4.40	23.90	43.40
2006-09	CWO-4	0170	45	2.98	20.82	40.08
2006-09	CWO-4	0205	0			
2006-09	CWO-4	0210	14	2.20	20.18	39.94
2006-09	CWO-4	0306	18	2.55	22.70	42.03
2006-09	CWO-4	0430	12	2.60	18.58	38.88
2006-09	CWO-4	0610	8	3.00	17.68	38.52
2006-09	CWO-4	0640	4	4.33	19.17	38.33
2006-09	CWO-4	0650	3	2.60	19.35	43.50
2006-09	CWO-4	0803	3	2.40	19.70	40.50
2006-09	CWO-4	0930	3	3.05	22.80	41.85
2006-09	CWO-4	1120	7	3.43	21.40	42.08
2006-09	CWO-4	1310	11	3.13	20.38	40.08
2006-09	CWO-4	1390	6	3.72	22.56	41.86
2006-09	CWO-4	2110	4	3.05	21.00	41.35
2006-09	CWO-4	2120	8	3.35	20.88	41.35
2006-09	CWO-4	2125	2	3.00	21.60	44.15
2006-09	CWO-4	2305	2	2.00	21.70	42.20
2006-09	CWO-4	2340	7	2.35	18.33	37.18
2006-09	CWO-4	2510	0			
2006-09	CWO-4	2602	9	2.83	19.48	39.38
2006-09	CWO-4	2805	13	2.05	20.80	40.13
2006-09	CWO-4	2810	0			
2006-09	CWO-4	3010	7	2.90	22.03	41.53
2006-09	CWO-4	3102	1	4.00	23.20	41.20
2006-09	CWO-4	3302	0			
2006-09	CWO-4	3402	7	3.43	20.37	39.33
2006-09	CWO-4	3408	5	2.80	19.77	40.77
2006-09	CWO-4	3410	1	2.00	20.20	41.20
2006-09	CWO-4	3510	22	2.98	20.04	39.66
2006-09	CWO-4	4010	0			
2006-09	CWO-4	4130	2	2.50	21.20	44.30
2006-09	CWO-4	4430	5	3.45	19.58	41.43
2006-09	CWO-4	4602	4	2.00	18.85	37.80
2006-09	CWO-4	4810	0			
2006-09	CWO-4	5502	1	4.60	19.10	49.20
2006-09	CWO-4	5702	22	2.98	19.23	38.98
2006-09	CWO-4	5804	4	3.33	21.50	40.97
2006-09	CWO-4	5805	3	3.10	22.17	42.27
2006-09	CWO-4	5910	2	2.00	20.45	39.95
2006-09	CWO-4	5950	1	3.70	17.40	41.00
2006-09	CWO-4	5970	1	3.00	18.70	40.90
2006-09	CWO-4	6004	17	2.56	20.28	39.44
2006-09	CWO-4	6302	13	2.58	19.90	39.35
2006-09	CWO-4	6502	11	2.05	20.48	41.15
2006-09	CWO-4	6604	5	2.60	20.63	39.90
2006-09	CWO-4	6802	3	3.00	19.00	38.15
2006-09	CWO-4	7002	6	2.70	19.57	39.10
2006-09	CWO-4	7380	2	5.00	20.95	40.10
2006-09	CWO-4	9805	1	3.00	18.80	44.60
2006-09	CWO-4	9815	3	2.50	18.95	37.70
2006-09	CWO-4	9925	4	3.00	19.85	40.15

APPENDIX L - WO, CWO & LDO TIG, TIS & AGE

YEAR	RANK	MOS	SEL	AVG TIG	AVG TIS	AVG AGE
2006-09	CWO-3	ALL	763	2.94	16.97	36.91
2006-09	CWO-3	0160	7	2.50	18.83	38.78
2006-09	CWO-3	0170	74	3.13	18.43	37.90
2006-09	CWO-3	0205	0			
2006-09	CWO-3	0210	23	2.58	15.95	35.62
2006-09	CWO-3	0306	26	2.53	20.45	40.05
2006-09	CWO-3	0430	41	3.00	15.09	34.53
2006-09	CWO-3	0610	14	2.42	15.78	36.30
2006-09	CWO-3	0640	12	3.33	16.38	35.67
2006-09	CWO-3	0650	15	2.00	16.00	36.57
2006-09	CWO-3	0803	9	2.80	17.24	37.20
2006-09	CWO-3	0930	6	2.65	17.05	36.25
2006-09	CWO-3	1120	13	3.00	16.46	35.86
2006-09	CWO-3	1310	22	3.28	16.73	36.65
2006-09	CWO-3	1390	11	3.76	18.02	37.92
2006-09	CWO-3	2110	22	3.04	16.08	35.54
2006-09	CWO-3	2120	22	2.88	18.12	37.64
2006-09	CWO-3	2125	2	3.50	17.40	35.60
2006-09	CWO-3	2305	18	2.00	16.88	36.83
2006-09	CWO-3	2340	19	2.40	16.13	36.28
2006-09	CWO-3	2510	0			
2006-09	CWO-3	2602	15	2.78	17.98	37.20
2006-09	CWO-3	2805	28	2.74	17.09	37.00
2006-09	CWO-3	2810	0			
2006-09	CWO-3	3010	12	2.68	18.32	37.40
2006-09	CWO-3	3102	9	2.27	16.77	35.67
2006-09	CWO-3	3302	12	2.00	16.40	36.93
2006-09	CWO-3	3402	11	3.33	16.87	37.52
2006-09	CWO-3	3408	14	3.63	18.42	39.47
2006-09	CWO-3	3410	6	2.00	18.95	40.10
2006-09	CWO-3	3510	34	3.60	16.53	36.40
2006-09	CWO-3	4010	0			
2006-09	CWO-3	4130	5	2.00	13.40	33.20
2006-09	CWO-3	4430	8	3.50	15.80	37.94
2006-09	CWO-3	4602	11	3.00	15.86	35.38
2006-09	CWO-3	4810	2	3.50	19.20	38.20
2006-09	CWO-3	5502	2	3.50	18.60	38.20
2006-09	CWO-3	5702	45	3.33	15.80	34.93
2006-09	CWO-3	5804	8	3.70	16.95	38.45
2006-09	CWO-3	5805	4	2.33	16.87	36.67
2006-09	CWO-3	5910	7	2.50	19.18	38.00
2006-09	CWO-3	5950	8	2.77	15.50	35.03
2006-09	CWO-3	5970	4	3.70	15.85	37.30
2006-09	CWO-3	6004	46	2.88	16.40	36.90
2006-09	CWO-3	6302	33	3.37	18.10	37.61
2006-09	CWO-3	6502	31	2.05	16.55	36.35
2006-09	CWO-3	6604	17	3.22	17.30	37.30
2006-09	CWO-3	6802	8	2.33	15.27	36.43
2006-09	CWO-3	7002	16	2.92	15.68	35.30
2006-09	CWO-3	7380	8	3.13	16.67	36.53
2006-09	CWO-3	9805	0			
2006-09	CWO-3	9815	3	2.83	16.50	39.77

APPENDIX M - WO, CWO, & LDO SELECTION RESULTS

YEAR	RANK	MOS	CON	SEL	SEL%	% OF SEL
2010	WO	ALL	602	243	40.37%	
2010	WO	0210	42	28	66.67%	11.52%
2010	WO	0430	28	22	78.57%	9.05%
2010	WO	0170	28	21	75.00%	8.64%
2010	WO	6302	65	14	21.54%	5.76%
2010	WO	5702	23	13	56.52%	5.35%
2010	WO	1310	20	12	60.00%	4.94%
2010	WO	0205	22	10	45.45%	4.12%
2010	WO	6502	23	9	39.13%	3.70%
2010	WO	0610	7	7	100.00%	2.88%
2010	WO	0620	12	7	58.33%	2.88%
2010	WO	2305	9	7	77.78%	2.88%
2010	WO	2110	18	6	33.33%	2.47%
2010	WO	3010	16	6	37.50%	2.47%
2010	WO	3510	26	6	23.08%	2.47%
2010	WO	7002	11	6	54.55%	2.47%
2010	WO	2805	31	5	16.13%	2.06%
2010	WO	3302	7	5	71.43%	2.06%
2010	WO	6004	50	5	10.00%	2.06%
2010	WO	6802	11	5	45.45%	2.06%
2010	WO	3408	4	4	100.00%	1.65%
2010	WO	5950	9	4	44.44%	1.65%
2010	WO	0160	4	3	75.00%	1.23%
2010	WO	0650	23	3	13.04%	1.23%
2010	WO	0803	11	3	27.27%	1.23%
2010	WO	1390	8	3	37.50%	1.23%
2010	WO	2120	12	3	25.00%	1.23%
2010	WO	2340	16	3	18.75%	1.23%
2010	WO	2602	12	3	25.00%	1.23%
2010	WO	3402	5	3	60.00%	1.23%
2010	WO	3102	6	2	33.33%	0.82%
2010	WO	4130	4	2	50.00%	0.82%
2010	WO	5805	6	2	33.33%	0.82%
2010	WO	5970	6	2	33.33%	0.82%
2010	WO	6604	8	2	25.00%	0.82%
2010	WO	1120	6	1	16.67%	0.41%
2010	WO	2125	2	1	50.00%	0.41%
2010	WO	4430	2	1	50.00%	0.41%
2010	WO	4602	2	1	50.00%	0.41%
2010	WO	5502	5	1	20.00%	0.41%
2010	WO	5804	1	1	100.00%	0.41%
2010	WO	5910	1	1	100.00%	0.41%

APPENDIX M - WO, CWO, & LDO SELECTION RESULTS

YEAR	RANK	MOS	CON	SEL	SEL%	% OF SEL
2005-12	CWO-3	ALL	2362	1562	66.13%	
2005-12	CWO-3	0170	247	172	69.64%	11.01%
2005-12	CWO-3	0430	121	91	75.21%	5.83%
2005-12	CWO-3	6004	117	87	74.36%	5.57%
2005-12	CWO-3	5702	130	86	66.15%	5.51%
2005-12	CWO-3	6302	112	76	67.86%	4.87%
2005-12	CWO-3	3510	120	66	55.00%	4.23%
2005-12	CWO-3	0306	86	63	73.26%	4.03%
2005-12	CWO-3	2805	75	59	78.67%	3.78%
2005-12	CWO-3	0210	70	58	82.86%	3.71%
2005-12	CWO-3	6502	62	51	82.26%	3.27%
2005-12	CWO-3	2120	60	44	73.33%	2.82%
2005-12	CWO-3	2110	62	43	69.35%	2.75%
2005-12	CWO-3	1310	88	41	46.59%	2.62%
2005-12	CWO-3	2305	41	41	100.00%	2.62%
2005-12	CWO-3	2340	49	39	79.59%	2.50%
2005-12	CWO-3	0650	43	34	79.07%	2.18%
2005-12	CWO-3	2602	40	30	75.00%	1.92%
2005-12	CWO-3	6604	52	28	53.85%	1.79%
2005-12	CWO-3	3302	33	27	81.82%	1.73%
2005-12	CWO-3	0610	48	25	52.08%	1.60%
2005-12	CWO-3	1120	59	25	42.37%	1.60%
2005-12	CWO-3	0640	41	24	58.54%	1.54%
2005-12	CWO-3	3010	42	24	57.14%	1.54%
2005-12	CWO-3	7002	41	24	58.54%	1.54%
2005-12	CWO-3	3408	39	23	58.97%	1.47%
2005-12	CWO-3	1390	54	22	40.74%	1.41%
2005-12	CWO-3	3402	45	22	48.89%	1.41%
2005-12	CWO-3	3102	27	20	74.07%	1.28%
2005-12	CWO-3	5950	27	18	66.67%	1.15%
2005-12	CWO-3	0803	35	17	48.57%	1.09%
2005-12	CWO-3	4602	25	17	68.00%	1.09%
2005-12	CWO-3	6802	21	16	76.19%	1.02%
2005-12	CWO-3	5970	16	14	87.50%	0.90%
2005-12	CWO-3	0160	23	12	52.17%	0.77%
2005-12	CWO-3	4430	28	12	42.86%	0.77%
2005-12	CWO-3	5804	22	12	54.55%	0.77%
2005-12	CWO-3	5910	17	12	70.59%	0.77%
2005-12	CWO-3	9925	19	10	52.63%	0.64%
2005-12	CWO-3	0205	9	9	100.00%	0.58%
2005-12	CWO-3	0930	13	9	69.23%	0.58%
2005-12	CWO-3	7380	14	8	57.14%	0.51%
2005-12	CWO-3	4130	12	7	58.33%	0.45%
2005-12	CWO-3	4810	9	7	77.78%	0.45%
2005-12	CWO-3	5502	15	7	46.67%	0.45%
2005-12	CWO-3	2810	6	6	100.00%	0.38%
2005-12	CWO-3	3410	7	6	85.71%	0.38%
2005-12	CWO-3	5805	8	6	75.00%	0.38%
2005-12	CWO-3	9815	12	5	41.67%	0.32%
2005-12	CWO-3	4010	4	4	100.00%	0.26%
2005-12	CWO-3	2125	2	2	100.00%	0.13%
2005-12	CWO-3	2510	14	1	7.14%	0.06%
2005-12	CWO-3	9805	0	0	0.00%	0.00%

APPENDIX M - WO, CWO, & LDO SELECTION RESULTS

YEAR	RANK	MOS	CON	SEL	SEL%	% OF SEL
2005-12	CWO-4	ALL	1234	680	55.11%	
2005-12	CWO-4	0170	205	95	46.34%	13.97%
2005-12	CWO-4	5702	96	45	46.88%	6.62%
2005-12	CWO-4	0306	45	40	88.89%	5.88%
2005-12	CWO-4	3510	83	36	43.37%	5.29%
2005-12	CWO-4	6004	49	35	71.43%	5.15%
2005-12	CWO-4	0430	49	28	57.14%	4.12%
2005-12	CWO-4	0210	29	26	89.66%	3.82%
2005-12	CWO-4	2805	30	25	83.33%	3.68%
2005-12	CWO-4	6302	48	25	52.08%	3.68%
2005-12	CWO-4	1310	58	23	39.66%	3.38%
2005-12	CWO-4	2602	23	17	73.91%	2.50%
2005-12	CWO-4	6502	21	17	80.85%	2.50%
2005-12	CWO-4	0610	25	15	60.00%	2.21%
2005-12	CWO-4	2120	32	15	46.88%	2.21%
2005-12	CWO-4	6604	33	15	45.45%	2.21%
2005-12	CWO-4	2340	19	13	68.42%	1.91%
2005-12	CWO-4	1390	31	12	38.71%	1.76%
2005-12	CWO-4	2110	27	12	44.44%	1.76%
2005-12	CWO-4	3408	26	12	46.15%	1.76%
2005-12	CWO-4	1120	29	11	37.93%	1.62%
2005-12	CWO-4	3402	30	11	36.67%	1.62%
2005-12	CWO-4	7002	29	11	37.93%	1.62%
2005-12	CWO-4	3010	26	10	38.46%	1.47%
2005-12	CWO-4	0640	22	9	40.91%	1.32%
2005-12	CWO-4	0803	14	9	64.29%	1.32%
2005-12	CWO-4	0650	11	8	72.73%	1.18%
2005-12	CWO-4	4430	15	8	53.33%	1.18%
2005-12	CWO-4	0160	14	7	50.00%	1.03%
2005-12	CWO-4	0930	9	7	77.78%	1.03%
2005-12	CWO-4	5805	7	6	85.71%	0.88%
2005-12	CWO-4	9925	10	6	60.00%	0.88%
2005-12	CWO-4	2305	5	5	100.00%	0.74%
2005-12	CWO-4	3302	6	5	83.33%	0.74%
2005-12	CWO-4	4130	7	5	71.43%	0.74%
2005-12	CWO-4	4602	5	5	100.00%	0.74%
2005-12	CWO-4	5804	10	5	50.00%	0.74%
2005-12	CWO-4	5950	6	5	83.33%	0.74%
2005-12	CWO-4	6802	12	5	41.67%	0.74%
2005-12	CWO-4	5502	7	4	57.14%	0.59%
2005-12	CWO-4	7380	7	4	57.14%	0.59%
2005-12	CWO-4	9815	5	4	80.00%	0.59%
2005-12	CWO-4	2125	3	3	100.00%	0.44%
2005-12	CWO-4	2510	6	3	50.00%	0.44%
2005-12	CWO-4	3102	3	3	100.00%	0.44%
2005-12	CWO-4	4810	7	3	42.86%	0.44%
2005-12	CWO-4	5910	4	3	75.00%	0.44%
2005-12	CWO-4	5970	9	3	33.33%	0.44%
2005-12	CWO-4	2810	3	2	66.67%	0.29%
2005-12	CWO-4	9805	2	2	100.00%	0.29%
2005-12	CWO-4	3410	1	1	100.00%	0.15%
2005-12	CWO-4	4010	2	1	50.00%	0.15%
2005-12	CWO-4	0205	0	0	0.00%	0.00%

APPENDIX M - WO, CWO, & LDO SELECTION RESULTS

YEAR	RANK	MOS	CON	SEL	SEL%	% OF SEL
2005-12	CWO-5	ALL	501	207	41.32%	
2005-12	CWO-5	0170	102	29	28.43%	14.01%
2005-12	CWO-5	0306	28	16	57.14%	7.73%
2005-12	CWO-5	5702	58	16	27.59%	7.73%
2005-12	CWO-5	3510	35	13	37.14%	6.28%
2005-12	CWO-5	6004	34	12	35.29%	5.80%
2005-12	CWO-5	0210	16	9	56.25%	4.35%
2005-12	CWO-5	6302	35	9	25.71%	4.35%
2005-12	CWO-5	1310	16	6	37.50%	2.90%
2005-12	CWO-5	0430	16	5	31.25%	2.42%
2005-12	CWO-5	0610	14	5	35.71%	2.42%
2005-12	CWO-5	2602	6	5	83.33%	2.42%
2005-12	CWO-5	6604	6	5	83.33%	2.42%
2005-12	CWO-5	1120	11	4	36.36%	1.93%
2005-12	CWO-5	2110	11	4	36.36%	1.93%
2005-12	CWO-5	2805	5	4	80.00%	1.93%
2005-12	CWO-5	3010	5	4	80.00%	1.93%
2005-12	CWO-5	3402	9	4	44.44%	1.93%
2005-12	CWO-5	3408	6	4	66.67%	1.93%
2005-12	CWO-5	6502	11	4	36.36%	1.93%
2005-12	CWO-5	0640	6	3	50.00%	1.45%
2005-12	CWO-5	0930	3	3	100.00%	1.45%
2005-12	CWO-5	1390	4	3	75.00%	1.45%
2005-12	CWO-5	2120	8	3	37.50%	1.45%
2005-12	CWO-5	2305	3	3	100.00%	1.45%
2005-12	CWO-5	5970	5	3	60.00%	1.45%
2005-12	CWO-5	7002	9	3	33.33%	1.45%
2005-12	CWO-5	0160	3	2	66.67%	0.97%
2005-12	CWO-5	0803	3	2	66.67%	0.97%
2005-12	CWO-5	2340	3	2	66.67%	0.97%
2005-12	CWO-5	3302	5	2	40.00%	0.97%
2005-12	CWO-5	4430	2	2	100.00%	0.97%
2005-12	CWO-5	4810	5	2	40.00%	0.97%
2005-12	CWO-5	5805	3	2	66.67%	0.97%
2005-12	CWO-5	5950	4	2	50.00%	0.97%
2005-12	CWO-5	6802	2	2	100.00%	0.97%
2005-12	CWO-5	0650	2	1	50.00%	0.48%
2005-12	CWO-5	3410	1	1	100.00%	0.48%
2005-12	CWO-5	4130	1	1	100.00%	0.48%
2005-12	CWO-5	4602	3	1	33.33%	0.48%
2005-12	CWO-5	5502	2	1	50.00%	0.48%
2005-12	CWO-5	5804	2	1	50.00%	0.48%
2005-12	CWO-5	5910	1	1	100.00%	0.48%
2005-12	CWO-5	7380	1	1	100.00%	0.48%
2005-12	CWO-5	9815	2	1	50.00%	0.48%
2005-12	CWO-5	9925	3	1	33.33%	0.48%
2005-12	CWO-5	0205	0	0	0.00%	0.00%
2005-12	CWO-5	2125	0	0	0.00%	0.00%
2005-12	CWO-5	2510	0	0	0.00%	0.00%
2005-12	CWO-5	2810	2	0	0.00%	0.00%
2005-12	CWO-5	3102	0	0	0.00%	0.00%
2005-12	CWO-5	4010	0	0	0.00%	0.00%
2005-12	CWO-5	9805	0	0	0.00%	0.00%

APPENDIX M - WO, CWO, & LDO SELECTION RESULTS

YEAR	RANK	MOS	CON	SEL	SEL%	% OF SEL
2005-13	MAJOR LDO	ALL	682	350	51.32%	
2005-13	MAJOR LDO	0430	101	57	56.44%	16.29%
2005-13	MAJOR LDO	6302	68	39	57.35%	11.14%
2005-13	MAJOR LDO	2802	78	38	48.72%	10.86%
2005-13	MAJOR LDO	2102	68	33	48.53%	9.43%
2005-13	MAJOR LDO	5902	61	33	54.10%	9.43%
2005-13	MAJOR LDO	6502	68	33	48.53%	9.43%
2005-13	MAJOR LDO	6004	63	29	46.03%	8.29%
2005-13	MAJOR LDO	2340	52	23	44.23%	6.57%
2005-13	MAJOR LDO	2305	27	19	70.37%	5.43%
2005-13	MAJOR LDO	3302	19	12	63.16%	3.43%
2005-13	MAJOR LDO	3102	22	11	50.00%	3.14%
2005-13	MAJOR LDO	6802	19	7	36.84%	2.00%
2005-13	MAJOR LDO	0650	17	6	35.29%	1.71%
2005-13	MAJOR LDO	4010	4	4	100.00%	1.14%
2005-13	MAJOR LDO	4602	11	4	36.36%	1.14%
2005-13	MAJOR LDO	3410	4	2	50.00%	0.57%

YEAR	RANK	MOS	CON	SEL	SEL%	% OF SEL
2005-13	LTCOL LDO	ALL	301	110	36.54%	
2005-13	LTCOL LDO	0430	49	17	34.69%	15.45%
2005-13	LTCOL LDO	2102	38	12	31.58%	10.91%
2005-13	LTCOL LDO	6004	27	12	44.44%	10.91%
2005-13	LTCOL LDO	2340	17	11	64.71%	10.00%
2005-13	LTCOL LDO	2802	40	10	25.00%	9.09%
2005-13	LTCOL LDO	6502	31	10	32.26%	9.09%
2005-13	LTCOL LDO	2305	14	9	64.29%	8.18%
2005-13	LTCOL LDO	6302	43	9	20.93%	8.18%
2005-13	LTCOL LDO	5902	19	6	31.58%	5.45%
2005-13	LTCOL LDO	3102	9	5	55.56%	4.55%
2005-13	LTCOL LDO	3302	6	4	66.67%	3.64%
2005-13	LTCOL LDO	0650	3	2	66.67%	1.82%
2005-13	LTCOL LDO	0210	1	1	100.00%	0.91%
2005-13	LTCOL LDO	4602	1	1	100.00%	0.91%
2005-13	LTCOL LDO	6802	3	1	33.33%	0.91%

APPENDIX K - 0402 MOS DESCRIPTION

MOS 0402, Logistics Officer (I) (LtCol1 to 2ndLt) PMOS

a. Summary. Logistics officers plan, coordinate, execute and/or supervise the execution of all logistics functions and the six functional areas of tactical logistics: supply, maintenance, transportation, general engineering, health services, and services. Logistics officers serve as commanders or assistants to the commanders of tactical logistics units/elements and as members of general or executive staffs in the operating forces, supporting establishment, and joint staffs. They perform duties of mobility officer, maintenance management officer, motor transport officer, landing support officers, and are responsible for administrative and tactical unit movement of personnel, supplies, and equipment by all modes of transportation.

b. Prerequisites. See requirements.

c. Requirements. Complete the Logistics Officer Course, Logistics Operations School, Marine Corps Combat Service Support Schools, Camp Johnson/Camp Lejeune, NC.

d. Duties. For a complete listing of duties and tasks, refer to reference (h), Logistics Training and Readiness Manual.

e. Related SOC Classification/SOC Code. Logisticians 13-1081.

f. Related Military Skill. None.

APPENDIX L - 0402 T&R PERFORMANCE EVENTS

0402-ENG-1001: Coordinate general engineering support

GRADES: 2NDLT, 1STLT, CAPT

INITIAL TRAINING SETTING: FORMAL

CONDITION: Given a requirement, personnel, and equipment.

STANDARD: To ensure engineering requirements are incorporated into the Combat Service Support (CSS) plan.

PERFORMANCE STEPS:

1. Identify the sub-functions of general engineering.
2. Identify organic/non-organic general engineering capabilities.
3. Coordinate the employment of engineering assets.
4. Monitor general engineering operations.

0402-GEN-1002: Perform the general duties of a logistics officer

GRADES: 2NDLT, 1STLT, CAPT

INITIAL TRAINING SETTING: FORMAL

CONDITION: Given the commander's guidance, mission, and resources.

STANDARD: To provide oversight on the functional areas of logistics.

PERFORMANCE STEPS:

1. Integrate the functional areas of logistics.
2. Review logistics related reports.
3. Prepare logistics reports.
4. Advise commander on logistics related matters.
5. Conduct logistics training.
6. Conduct inspections.
7. Identify MAGTF/SE logistics agencies/capabilities.
8. Monitor supply levels.
9. Monitor equipment status.
10. Prepare standard operating procedures.
11. Review unit T/O&E.
12. Manage unit ammunition requirements.
13. Manage unit ammunition handling procedures.
14. Supervise an environmental compliance program.

0402-HSS-1003: Coordinate health services support

GRADES: 2NDLT, 1STLT, CAPT

INITIAL TRAINING SETTING: FORMAL

CONDITION: Given a requirement, personnel, and equipment.

STANDARD: To integrate health services into the combat Service Support (CSS) plan.

PERFORMANCE STEPS:

1. Identify organic/non-organic Health Service Support (HSS) capabilities.
2. Integrate the five sub-functions of HSS into planning.
3. Identify requirements.
4. Identify levels of medical care.
5. Monitor unit medical/dental readiness.
6. Identify responsibilities of HSS personnel.
7. Monitor special health service programs.

0402-MNT-1004: Coordinate maintenance support

GRADES: 2NDLT, 1STLT, CAPT

INITIAL TRAINING SETTING: FORMAL

CONDITION: Given a requirement, personnel, and equipment.

STANDARD: To ensure maintenance support satisfies unit's mission.

PERFORMANCE STEPS:

1. Identify the eight sub-functions of maintenance.
2. Identify organic/non-organic maintenance capabilities.

APPENDIX L - 0402 T&R PERFORMANCE EVENTS

3. Monitor maintenance related programs (e.g. corrosion control, modifications etc.).
4. Conduct Operational Risk Management (ORM) for maintenance activities.
5. Coordinate recovery operations.
6. Identify/allocate maintenance resources.
7. Validate maintenance resources/requirements.
8. Reconcile with supporting agencies.
9. Establish maintenance operational concepts (e.g. mobile contact/support teams etc.).
10. Establish pre-expended bins (PEB).
11. Establish internal management control programs.
12. Advise commander on maintenance issues/capabilities.
13. Manage hazardous materials and waste.

0402-OPS-1005: Perform the duties of a maintenance management officer

GRADES: 2NDLT, 1STLT, CAPT

INITIAL TRAINING SETTING: FORMAL

CONDITION: Given a requirement, personnel, and equipment.

STANDARD: To ensure the effective use of personnel, money, facilities, and material as applied to the maintenance of ground equipment is controlled.

PERFORMANCE STEPS:

1. Manage maintenance administration.
2. Manage personnel and training.
3. Manage records and reports.
4. Manage publications control.
5. Manage operational availability.
6. Manage maintenance operations.
7. Manage supply support.
8. Manage maintenance related programs.
9. Establish/review internal maintenance management policy.
10. Monitor unit equipment readiness.
11. Identify organic/non-organic maintenance capabilities.
12. Monitor the maintenance automated information systems.
13. Validate and monitor use of the Uniformed Materiel Management Issue and Priority System (UMMIPS).
14. Direct maintenance management validation/reconciliation.
15. Implement a maintenance inspection program.

0402-OPS-1006: Perform the duties of an arms ammunition and explosives (AA&E) officer

GRADES: 2NDLT, 1STLT, CAPT

INITIAL TRAINING SETTING: FORMAL

CONDITION: Given a requirement, personnel, and equipment

STANDARD: To ensure compliance

PERFORMANCE STEPS:

1. Supervise AA&E operations.
2. Review AA&E account.
3. Adhere to accountability procedures.
4. Validate AA&E records.
5. Coordinate with internal/external agencies.
6. Monitor AA&E security procedures.
7. Conduct inspections.

0402-OPS-1007: Perform the duties of a motor transport officer

BILLETS: Company Commander, Motor Transport Officer, Platoon Commander

GRADES: 2NDLT, 1STLT, CAPT

INITIAL TRAINING SETTING: FORMAL

APPENDIX L - 0402 T&R PERFORMANCE EVENTS

CONDITION: Given a requirement, personnel, and equipment.

STANDARD: To ensure transportation support requirements are met.

PERFORMANCE STEPS:

1. Monitor the dispatching of equipment.
2. Supervise equipment readiness.
3. Identify equipment capabilities.
4. Manage forms/records.
5. Manage a licensing program.
6. Determine a unit's operator requirements.
7. Supervise maintenance management programs.
8. Supervise on vehicle equipment (OVE)/basic issue items (BII) procedures.
9. Supervise maintenance in accordance with capabilities.
10. Supervise convoy operations.
11. Manage training of organic personnel.
12. Manage hazardous materials and waste.
13. Manage transportation of ammunition and hazardous materials.

0402-OPS-1008: Perform the duties of a convoy commander

BILLETS: Company Commander, Motor Transport Officer, Platoon Commander

GRADES: 2NDLT, 1STLT, CAPT

INITIAL TRAINING SETTING: FORMAL

CONDITION: Given a requirement, personnel, and equipment.

STANDARD: To ensure unit movement is completed to support the mission.

PERFORMANCE STEPS:

1. Review intelligence reports.
2. Determine lift requirements.
3. Coordinate route reconnaissance.
4. Develop a movement plan.
5. Coordinate CAS/Medevac support procedures.
6. Direct loading operations.
7. Conduct a convoy commander's brief.
8. Conduct pre-combat actions, checks/inspections.
9. Direct the movement of the convoy.
10. Direct the defense of the convoy.
11. Supervise vehicle fording operations.
12. Supervise vehicle recovery operations.
13. Supervise field expedient repairs.
14. Supervise limited visibility driving operations.
15. Conduct mission debrief.
16. Prepare mission after-action brief.

0402-OPS-1009: Perform the duties of a landing support platoon commander

BILLETS: Platoon Commander

GRADES: 2NDLT, 1STLT, CAPT

INITIAL TRAINING SETTING: FORMAL

CONDITION: Given the requirement to plan landing support and throughput operations.

STANDARD: To support the unit's mission and the Commander's concept of operations.

PERFORMANCE STEPS:

1. Supervise landing support operations.
2. Direct material handling and heavy equipment.
3. Determine tactical logistics (TACLOG) control procedures.
4. Determine Landing Support control procedures.
5. Supervise beach operations group.
6. Supervise port operations Group.
7. Supervise A/DACG.

APPENDIX L - 0402 T&R PERFORMANCE EVENTS

8. Supervise rail head operations group.
9. Supervise helicopter support team operations.
10. Coordinate with higher and supporting agencies.
11. Develop throughput process.
12. Coordinate ship to shore movement.
13. Coordinate movement control requirements.
14. Coordinate inspection requirements.
15. Supervise the establishment of the beach support area.
16. Conduct physical network analysis.
17. Identify port capabilities.

0402-OPS-1010: Perform the duties of an armory officer

BILLETS: Armory Officer

GRADES: 2NDLT, 1STLT, CAPT

INITIAL TRAINING SETTING: FORMAL

CONDITION: Given a requirement, personnel, and equipment.

STANDARD: To ensure compliance with established orders and procedures.

PERFORMANCE STEPS:

1. Verify unit ordnance allowance.
2. Determine armory storage requirements.
3. Supervise a weapons maintenance program for a unit.
4. Provide training for armory personnel.
5. Ensure compliance with AA&E security requirements.
6. Verify weapons accountability procedures.
7. Supervise field armory operations.

0402-OPS-1011: Establish a combat service support area (CSSA)

GRADES: 2NDLT, 1STLT, CAPT, MAJ

INITIAL TRAINING SETTING: FORMAL

CONDITION: Given a requirement, personnel, and equipment.

STANDARD: To sustain operations ashore.

PERFORMANCE STEPS:

1. Plan the management of subsistence.
2. Plan the management of bulk and packaged POLs.
3. Plan the management of ammunition.
4. Plan the management of health service support (HSS).
5. Plan the management of supply/maintenance.
6. Identify doctrinal Combat Service Support areas.
7. Identify procedures used to establish CSS areas.
8. Coordinate Security plan/requirements.
9. Coordinate the employment of military police.
10. Plan the management of enemy prisoners of war.
11. Plan the management of enemy detainees.
12. Plan the management of displaced persons/refugees.
13. Coordinate the Area Damage Control (ADC) effort.
14. Coordinate general engineering requirements.
15. Coordinate services.

0402-OPS-1012: Supervise tactical logistics operations

BILLETS: Assistant Operations Officer, Logistics Officer, Watch Officer

GRADES: 2NDLT, 1STLT, CAPT

INITIAL TRAINING SETTING: FORMAL

CONDITION: Given a requirement, personnel, and equipment.

STANDARD: To ensure planning and oversight of tactical logistics functions to support mission requirements.

PERFORMANCE STEPS:

1. Support Marine Corps planning process (MCP).)

APPENDIX L - 0402 T&R PERFORMANCE EVENTS

2. Identify CSS capabilities/deficiencies.
3. Determine/forecast sustainment levels.
4. Determine a unit's resupply requirements.
5. Plan battlefield distribution operations.
6. Develop a concept of CSS.
7. Support development of logistics estimate, annexes, and orders.
8. Coordinate operations center procedures.
9. Establish battle rhythm.
10. Coordinate internal/external support requirements.
11. Monitor communications with HASS.
12. Coordinate aviation integration.
13. Monitor re-supply missions.
14. Analyze reports from HASS.
15. Monitor HASS logistics status reports.
16. Direct employment of CSS assets.
17. Monitor convoy operations.
18. Advise commander and higher headquarters.
19. Monitor common operational picture of logistics support (COP) utilizing C2 systems and AIS.

0402-SUP-1013: Coordinate supply support

GRADES: 2NDLT, 1STLT, CAPT

INITIAL TRAINING SETTING: FORMAL

CONDITION: Given a requirement, personnel, and equipment.

STANDARD: To ensure supply support satisfies unit's mission.

PERFORMANCE STEPS:

1. Identify a unit's sustainment requirements.
2. Review applicable supply support documents.
3. Identify the role of the unit supply section.
4. Identify supply processes used in support of logistics.
5. Identify classes of supply.
6. Identify sources of supply.
7. Supervise supply accountability procedures.
8. Monitor a unit's budget requirements.
9. Monitor funds for the unit.
10. Review budget and previous unit spending.
11. Identify deficiencies/changes in the annual budget.
12. Participate in the preparation of the midyear review.
13. Participate in the preparation/execution of the annual budget.
14. Identify salvage requirements.
15. Identify disposal requirements.
16. Submit malfunction and defect reports.
17. Monitor base property requirements.

0402-SVC-1014: Coordinate services support

GRADES: 2NDLT, 1STLT, CAPT

INITIAL TRAINING SETTING: FORMAL

CONDITION: Given a requirement, personnel, and equipment.

STANDARD: To integrate services into the Combat Service Support (CSS) plan.

PERFORMANCE STEPS:

1. Identify services support requirements.
2. Identify organic/non-organic capabilities.
3. Coordinate postal services.
4. Coordinate disbursing services.
5. Coordinate exchange services.
6. Coordinate mortuary affairs.
7. Coordinate legal services support.

APPENDIX L - 0402 T&R PERFORMANCE EVENTS

8. Supervise the operation of a dining facility.
9. Supervise the operation of a field mess.

0402-TRAN-1015: Coordinate transportation support

GRADES: 2NDLT, 1STLT, CAPT

INITIAL TRAINING SETTING: FORMAL

CONDITION: Given a requirement, personnel, and equipment.

STANDARD: To support the unit's mission and the Commanders concept of operations.

PERFORMANCE STEPS:

1. Identify the seven functions of transportation.
2. Identify transportation requirements.
3. Coordinate movement planning.
4. Support deployment and distribution planning through the use of Automated Information Systems (AIS).
5. Coordinate with Distribution Management Office (DMO).
6. Coordinate with movement control agencies.
7. Identify organic/non-organic support capabilities.
8. Prepare equipment and cargo for embarkation.
9. Prepare hazmat and cargo for transportation.
10. Coordinate air delivery planning.
11. Supervise LFSP operations.
12. Supervise material handling.
13. Supervise rail head operations.
14. Supervise motor transport operations.

4004. 2000-LEVEL EVENTS

0402-ENG-2001: Plan general engineering support

MOS PERFORMING: 0402, 1302, 3002

BILLETS: Logistics Officer, Operations Officer, Plans Officer

GRADES: CAPT, MAJ, LTCOL

INITIAL TRAINING SETTING: FORMAL

CONDITION: Given higher's operations order, commanders guidance, resources, while operating in a joint, coalition, inter-agency environment, as part of a MAGTF, provided with supported unit requirements and given priorities of engineer effort.

STANDARD: To properly task and resource engineers to establish the infrastructure necessary to conduct and sustain MAGTF operations.

PERFORMANCE STEPS:

1. Identify engineer mission requirements.
2. Identify organic/non-organic general engineering capabilities.
3. Identify MAGTF engineer command and support relationships.
4. Identify employment considerations for general engineering.
5. Identify the prioritized engineer project list process.
6. Coordinate engineer shortfalls (TO&E).
7. Manage CL IV materials.
8. Integrate engineer planning products into the Marine Corps Planning Process (MCPPE).
9. Integrate engineer information into appropriate C2 systems and collaborative tools within the COC.

0402-GEN-2002: Perform the general duties of an LCE operations officer

MOS PERFORMING: 0402, 1302, 3002

BILLETS: Logistics Officer, Operations Officer, Plans Officer

GRADES: CAPT, MAJ, LTCOL

INITIAL TRAINING SETTING: FORMAL

CONDITION: Given the commander's guidance, mission, and resources.

APPENDIX L - 0402 T&R PERFORMANCE EVENTS

STANDARD: To provide oversight on the functional areas of logistics.

PERFORMANCE STEPS:

1. Direct a combat operations center (COC).
2. Establish a combat operations center (COC).
3. Direct the security and organization of the combat operations center (COC).
4. Monitor communications with higher, adjacent, supported and supporting units.
5. Establish a battle rhythm.
6. Establish watch section personnel training.
7. Direct product development in support of the operations section.
8. Determine forward, main and rear CP capabilities/requirements.
9. Establish forward, main and rear CP capabilities.
10. Transition control of operations to forward, main or rear combat operations center (COC) as required.
11. Supervise in-transit visibility asset tracking.
12. Supervise total asset visibility.
13. Employ Automated Information Systems (AIS) to Support Deployment and Distribution Planning.
14. Establish C2 and log AIS.
15. Supervise the use of C2 and log AIS.
16. Monitor common operational picture of logistics support (COP) utilizing C2 systems and AIS.
17. Coordinate cross boundary movement.
18. Monitor convoy operations.
19. Manage unit movement coordination center (UMCC) operations.
20. Coordinate aviation integration.
21. Direct the Marine Corps Planning Process (MCPPE).
22. Determine logistics capabilities in Joint, interagency, NGO, Multinational and Coalition environment.
23. Determine MAGTF logistics capabilities.
24. Incorporate Naval Logistics Integration into planning.
25. Determine Defense Logistics Agency capabilities.
26. Plan Battlefield Distribution Operations.
27. Plan Combat Service Support Operations across the range of military operations.
28. Plan logistics to support civil military operations.
29. Plan logistics to support HADR operations.
30. Plan logistics to support peacekeeping operations.
31. Plan logistics to support defense support to civilian authorities.
32. Plan Support for Maritime Positioning Forces (MPF) Operations.
33. Identify cultural/regional effects on CSS Operations.
34. Coordinate non-organic support requirements.
35. Determine contracting requirements.
36. Understand the limitations/capabilities of a contingency contracting officer.
37. Coordinate force deployment planning and execution (FDP&E).
38. Coordinate reception staging onward movement and integration (RSO&I).
39. Coordinate reconstitution.

0402-HSS-2003: Plan health services support

MOS PERFORMING: 0402, 1302, 3002

BILLETS: Logistics Officer, Operations Officer, Plans Officer

GRADES: CAPT, MAJ, LTCOL

INITIAL TRAINING SETTING: FORMAL

CONDITION: Given the operation order, commander's guidance, resources, and the requirement to support a MAGTF.

APPENDIX L - 0402 T&R PERFORMANCE EVENTS

STANDARD: To ensure health services support, when integrated with the other functional areas of logistics, satisfies the unit's mission.

PERFORMANCE STEPS:

1. Identify health services support requirements.
2. Identify organic/non-organic health services support capabilities.
3. Coordinate health services support.
4. Identify casualty evacuation procedures.
5. Coordinate special programs.
6. Incorporate the appropriate level of care into the health service support plan.
7. Integrate health service support throughout the range of military operations.

0402-MNT-2004: Plan maintenance support

MOS PERFORMING: 0402, 1302, 3002

BILLETS: Logistics Officer, Operations Officer, Plans Officer

GRADES: CAPT, MAJ, LTCOL

INITIAL TRAINING SETTING: FORMAL

CONDITION: Given the operation order, commander's guidance, resources, and the requirement to support a MAGTF.

STANDARD: To ensure maintenance support, when integrated with the other functional areas of logistics, satisfies the unit's mission.

PERFORMANCE STEPS:

1. Identify maintenance requirements.
2. Identify maintenance capabilities.
3. Organize maintenance support to sustain scheme of maneuver.
4. Direct maintenance actions.
5. Monitor equipment readiness.
6. Monitor equipment reporting.
7. Coordinate intermediate maintenance support.
8. Identify field service representative capabilities/requirements.
9. Coordinate vehicle recovery operations.
10. Coordinate principal end item (PEI) rotation plan.

0402-OPS-2001: Perform a personnel jump from an aircraft

MOS PERFORMING: 0402, 0405

BILLETS: Air Delivery Officer, Assistant Operations Officer, Commanding Officer, Company Commander, Drop Zone Safety Officer, Executive Officer, Logistics Officer, MFF Jumpmaster, Operations Officer, Parachute Safety Officer, Platoon Commander

GRADES: 2NDLT, 1STLT, CAPT, MAJ, LTCOL

INITIAL TRAINING SETTING: FORMAL

CONDITION: Given an aircraft, drop-zone support team, and parachute system

STANDARD: Providing leadership oversight.

PERFORMANCE STEPS:

1. Attend jumpmaster brief.
2. Conduct pre-jump training.
3. Execute operational phase.
4. Execute recovery phase.
5. Attend debrief.

ADMINISTRATIVE INSTRUCTIONS: This is taught at CID A030CG1 Basic Airborne Course, Fort Benning, Georgia and CID: M50KLD1 Multi-Mission Parachute Course (MMPC) Coolidge, Arizona.

0402-OPS-2005: Coordinate a unit move

MOS PERFORMING: 0402, 1302, 3002

BILLETS: Logistics Officer, Operations Officer, Plans Officer

APPENDIX L - 0402 T&R PERFORMANCE EVENTS

GRADES: CAPT, MAJ, LTCOL

INITIAL TRAINING SETTING: FORMAL

CONDITION: Given a requirement to deploy across the range of military operations (ROMO).

STANDARD: To ensure units arrive mission capable in an area of operations.

PERFORMANCE STEPS:

1. Review the ConOps of the OpOrd to determine support requirement.
2. Determine lift requirements.
3. Formulate the embarkation plan.
4. Coordinate reception staging onward movement and integration (RSO&I).
5. Ensure equipment and cargo is prepared/certified for embarkation.
6. Coordinate with movement control organizations.
7. Supervise the submission of transportation requirements to higher headquarters.
8. Ensure movement training of unit personnel is conducted for deployment.
9. Ensure personnel are trained/certified for the submission of AIS products.
10. Supervise the submission of AIS data.
11. Track INTRA/INTER theater movement.
12. Disseminate a movement schedule to the appropriate units.
13. Supervise the movement.

0402-OPS-2006: Manage unit training

MOS PERFORMING: 0402, 1302, 3002

BILLETS: Logistics Officer, Operations Officer, Plans Officer

GRADES: CAPT, MAJ, LTCOL

INITIAL TRAINING SETTING: FORMAL

CONDITION: Given a unit, commander's guidance, METL, T&R Manuals, required external support and equipment, and references.

STANDARD: To ensure units are prepared to deploy globally in support of combatant commanders requirements.

PERFORMANCE STEPS:

1. Analyze Higher Headquarters' Mission Essential Task List (METL) in order to determine subordinate units' tasks.
2. Derive tasks from higher headquarters' Mission Essential Task List and translate into subordinate units' METs.
3. Identify core METs from associated T&R Manuals.
4. Develop training that supports subordinate units' METs.
5. Determine and procure requirements that support the training plan.
6. Use developed METs to determine the training tasks.
7. Identify and request the required resources.
8. Prepare a training concept.
9. Define the training objectives.
10. Review lessons learned/after action reports.
11. Integrate logistical support and C2 into training plan.
12. Incorporate ORM into the training plan.
13. Conduct the instruction.
14. Prepare combat standard operating procedures.
15. Prepare and prioritize mission specific requirements.
16. Create a battalion/regimental pre-deployment training plan.
17. Execute training, evaluation, and remediation.
18. Evaluate training IAW appropriate T&R manual.
19. Plan for remediation as required.
20. Update individual training records.
21. Provide inputs and oversight of the DRRS report.
22. Develop and implement validation of combat standard operation procedures.
23. Supervise the remediation plans.
24. Produce lessons learned/after action report.

APPENDIX L - 0402 T&R PERFORMANCE EVENTS

0402-OPS-2007: Direct the Marine Corps Planning Process (MCP)

MOS PERFORMING: 0402, 1302, 3002

BILLETS: Logistics Officer, Operations Officer, Plans Officer

GRADES: CAPT, MAJ, LTCOL

INITIAL TRAINING SETTING: FORMAL

CONDITION: Given the operation order, commander's guidance, resources, and the requirement to support a MAGTF.

STANDARD: Produce plans and orders which support the accomplishment of the mission and commander's intent.

PERFORMANCE STEPS:

1. Conduct problem framing.
2. Develop courses of action.
3. Wargame courses of action.
4. Compare and recommend courses of action.
5. Develop orders.
6. Execute transition.

0402-OPS-2008: Plan amphibious operations

MOS PERFORMING: 0402, 1302, 3002

BILLETS: Logistics Officer, Operations Officer, Plans Officer

GRADES: CAPT, MAJ, LTCOL

INITIAL TRAINING SETTING: FORMAL

CONDITION: Given personnel, the commander's guidance, mission, resources an amphibious operation, operations order, and landing plan.

STANDARD: To support MAGTF amphibious operations IAW the landing plan and concept of operations.

PERFORMANCE STEPS:

1. Identify the concept of amphibious operations.
2. Participate in the planning process for amphibious operations.
3. Publish required planning documentation.
4. Determine embarkation responsibilities.
5. Determine command and control for amphibious operations.
6. Establish a TACLOG.
7. Organize C4I for amphibious operations.
8. Determine logistics planning considerations.
9. Monitor CSS requests for ship-to-shore movement.
10. Coordinate ship-to-shore movement.
11. Determine ship-to-shore sustainment movement control requirements.
12. Monitor ship-to-shore movement.
13. Monitor the requested support movement ashore.

0402-SUP-2009: Plan supply support

MOS PERFORMING: 0402, 1302, 3002

BILLETS: Logistics Officer, Operations Officer, Plans Officer

GRADES: CAPT, MAJ, LTCOL

INITIAL TRAINING SETTING: FORMAL

CONDITION: Given a requirement, personnel, and equipment.

STANDARD: To ensure supply support, when integrated with the other functional areas of logistics, satisfies the unit's mission.

PERFORMANCE STEPS:

1. Identify requirements.
2. Identify organic/non-organic supply support capabilities/limitations.
3. Develop an operational deployment block in support of MAGTF operations.
4. Plan initial and sustainment supply requirements.
5. Facilitate MAGTF Distribution Management Operations (DMO).
6. Identify organic distribution capabilities/limitations.

APPENDIX L - 0402 T&R PERFORMANCE EVENTS

7. Determine reporting requirements.
8. Maintain MAGTF equipment accountability.
9. Manage a unit's budget.
10. Determine contracting support requirements.
11. Plan for aviation peculiar ground logistics supply support.

0402-SVC-2010: Plan services support

MOS PERFORMING: 0402, 1302, 3002

BILLETS: Logistics Officer, Operations Officer, Plans Officer

GRADES: CAPT, MAJ, LTCOL

INITIAL TRAINING SETTING: FORMAL

CONDITION: Given the operation order, commander's guidance, resources, and the requirement to support a MAGTF.

STANDARD: To ensure services support, when integrated with the other functional areas of logistics, satisfies the unit's mission.

PERFORMANCE STEPS:

1. Identify combat service support services capabilities.
2. Identify command services capabilities.
3. Identify the requirement for combat service support services.
4. Identify the requirement for command services.
5. Coordinate/plan the employment of combat service support services.

0402-TRAN-2011: Plan transportation support

MOS PERFORMING: 0402, 1302, 3002

BILLETS: Logistics Officer, Operations Officer, Plans Officer

GRADES: CAPT, MAJ, LTCOL

INITIAL TRAINING SETTING: FORMAL

CONDITION: Given the operation order, commander's guidance, resources, and the requirement to support a MAGTF.

STANDARD: To ensure transportation support, when integrated with the other functional areas of logistics, satisfies the unit's mission.

PERFORMANCE STEPS:

1. Identify transportation requirements.
2. Identify organic/non-organic transportation capabilities.
3. Coordinate force deployment planning and execution (FDP&E).
4. Validate Time phase force deployment data (TPFDD) products.
5. Coordinate movement planning.
6. Coordinate with movement control agencies.
7. Coordinate landing force support party (LFSP) operations.
8. Coordinate landing support operations.
9. Coordinate air delivery operations.
10. Coordinate helicopter support operations.
11. Coordinate beach operations.
12. Coordinate port operations.
13. Coordinate rail head operations.
14. Coordinate arrival/departure airfield control group operation.
15. Plan/coordinate convoy operations.
16. Direct motor transport operations.
17. Coordinate MHE support operations.
18. Review the operation order.
19. Formulate the embarkation plan.
20. Validate and prioritize unit's TEEP & operational requirements.
21. Ensure equipment and cargo is certified for embarkation.
22. Ensure HazMat is properly identified and documented for movement.
23. Ensure personnel are trained to use the current transportation AIS.
24. Track a unit move by INTRA/INTER theater assets.
25. Identify movement control organizations.

APPENDIX L - 0402 T&R PERFORMANCE EVENTS

26. Support deployment and distribution planning through the use of AIS.
27. Review the ConOps of the OpOrd to determine support requirement.
28. Identify US TransComm (Strategic Mobility) concept (AMLOC).
29. Forecast lift requirements.
30. Provide input regarding Force Deployment Planning and Execution.
31. Prepare requests for transportation.
32. Submit transportation requirements to higher headquarters.
33. Disseminate a movement schedule to the appropriate units.
34. Supervise embarkation/movement staging area Support MPF operations.

APPENDIX P - TOP 225 U.S. COLLEGES & UNIVERSITIES
MINIMUM SAT SCORE REQUIREMENT FOR ADMISSION

College	SAT M&CR	SAT M	SAT CR
Brigham Young University (UT)	N/A	N/A	N/A
Tuskegee University	879	441	438
Catawba College	982	488	494
Fisk University	976	492	484
<i>U.S. Marine Corps Commission Program</i>	1000	500	500
University of Nevada, Las Vegas	1015	501	514
West Virginia University	1042	514	528
Hampton University	1042	526	516
St. Bonaventure University	1054	523	531
University of California, Riverside	1057	504	553
Manhattanville College	1060	530	530
University of Wyoming	1065	524	541
Montana Tech of the Univ. of Montana	1069	530	539
Marist College	1071	506	565
Spelman College	1073	549	524
Bryant College	1079	522	557
Stephens College	1079	566	513
Morehouse College	1080	530	550
University of Maine, Augusta	1086	539	547
Whittier College	1086	547	539
Seton Hall University	1087	539	548
Westminster College (PA)	1087	544	543
University of New Orleans	1088	553	535
Arizona State University	1089	538	551
Ohio University	1090	540	550
Duquesne University	1090	545	545
University of Montana, Missoula	1090	550	540
University of Alabama, Tuscaloosa	1093	547	546
Simmons College	1096	554	542
Indiana University-Bloomington	1099	543	556
University of Arizona	1099	543	556
University of Tennessee, Knoxville	1100	551	549
Saint Anselm College	1107	551	556
DePaul University	1107	556	551
University of Idaho	1108	549	559
Auburn University	1110	547	563
Wagner College	1110	550	560
University of New Mexico	1112	572	540
Siena College	1117	550	567
Evergreen State College	1119	583	536
Guilford College	1120	570	550
Flagler College	1122	571	551
Hampden-Sydney College	1123	561	562
Seattle University	1123	562	561
Stetson University	1123	566	557
Warren Wilson College	1123	579	544
University of Denver	1124	555	569
University of South Carolina, Columbia	1124	555	569

College	SAT M&CR	SAT M	SAT CR
Eckerd College	1128	564	564
Hofstra University	1129	559	570
SAT Score of Marine Accessions N = 13,120	1129	565	565
Wells College	1130	580	550
Michigan State University	1131	552	579
University of Dayton	1132	557	575
Albertson College of Idaho	1134	571	563
Hanover College	1135	559	576
Wesley College	1136	574	562
University of California, Santa Cruz	1137	564	573
University of Redlands	1139	565	574
Hiram College	1139	573	566
St. Lawrence University	1140	570	570
William Jewell College	1140	580	560
Sweet Briar College	1140	590	550
University of Vermont	1142	568	574
Lake Forest College	1143	570	573
Albion College	1144	562	582
Elon College	1145	567	578
Hollins College	1145	595	550
Florida State University	1146	569	577
Loyola University Chicago	1148	574	574
Coe College	1149	577	572
Purdue University	1150	555	595
Marquette University	1150	560	590
Ohio Northern University	1150	560	590
Bellarmino University	1152	576	576
Northeastern University	1153	565	588
Samford University	1153	572	581
University of the Pacific	1154	559	595
SUNY at Buffalo	1155	566	589
Rollins College	1156	576	580
Randolph-Macon College	1156	592	564
Wittenberg University	1158	576	582
Mercer University	1158	578	580
University of Colorado, Boulder	1159	569	590
University of Nebraska, Lincoln	1159	570	589
University of San Diego	1160	570	590
University of North Carolina, Asheville	1160	586	574
University of Arkansas, Fayetteville	1163	576	587
Ohio State University, Columbus	1169	575	594
Gonzaga University	1171	578	593
University of California, Santa Barbara	1172	570	602
University of Oklahoma	1173	582	591
Clark University	1175	589	586
Texas A&M University, College Station	1178	576	602
Valparaiso University	1179	583	596
Calvin College	1179	584	595
Saint Louis University	1180	585	595
Millsaps College	1180	590	590
Goucher College	1180	605	575

College	SAT M&CR	SAT M	SAT CR
Eugene Lang College	1180	610	570
Providence College	1183	587	596
Wabash College	1185	576	609
College of Charleston	1185	595	590
Birmingham-Southern College	1186	598	588
Creighton University	1189	590	599
Cornell College	1189	599	590
College of Saint Benedict	1190	585	605
North Carolina State University	1193	578	615
The College of Wooster	1193	595	598
Michigan Technological University	1194	570	624
Fairfield University	1195	585	610
Allegheny College	1198	598	600
Miami University of Ohio	1200	590	610
Ripon College	1201	599	602
University of Pittsburgh	1202	595	607
Emerson College	1203	619	584
Clemson University	1205	587	618
University of Minnesota, Twin Cities	1205	593	612
Bradley University	1207	597	610
NM Institute of Mining & Technology	1208	596	612
Mary Washington College	1208	613	595
Iowa State University	1210	590	620
US Merchant Marine Academy	1210	600	610
Ohio Wesleyan University	1210	602	608
Agnes Scott College	1210	620	590
Earlham College	1210	620	590
College of the Atlantic	1210	624	586
Fordham University	1212	606	606
University of Maryland, Baltimore	1213	592	621
American University	1213	613	600
Centre College	1215	612	603
Denison University	1217	602	615
Santa Clara University	1219	601	618
Truman State University	1220	614	606
Oglethorpe University	1220	617	603
University of Dallas	1220	620	600
University of Texas, Austin	1222	596	626
Austin College	1227	614	613
DePauw University	1230	610	620
Gustavus Adolphus College	1230	610	620
University of Tulsa	1230	610	620
Willamette University	1230	620	610
California Polytechnic State University	1233	594	639
Pitzer College	1234	624	610
Loyola University	1234	629	605
University of California, Davis	1235	598	637
Dickinson College	1235	623	612
SUNY at Binghamton	1236	599	637
Wofford College	1236	612	624
Southwestern University	1236	621	615
Villanova University	1238	605	633

College	SAT M&CR	SAT M	SAT CR
University of California, San Diego	1239	593	646
Colorado School of Mines	1240	590	650
Pepperdine University	1240	612	628
George Washington University	1240	620	620
Hendrix College	1240	630	610
Wheaton College (MA)	1240	630	610
Simpson College	1240	640	600
SUNY College at Geneseo	1245	619	626
Lawrence University	1245	620	625
Colorado College	1247	622	625
Skidmore College	1250	630	620
Beloit College	1250	640	610
Sarah Lawrence College	1250	660	590
University of Puget Sound	1253	631	622
US Coast Guard Academy	1260	620	640
Occidental College	1260	630	630
Illinois Wesleyan University	1260	635	625
Kalamazoo College	1261	631	630
University of California, Los Angeles	1264	611	653
University of Wisconsin System, Madison	1265	613	652
University of North Carolina, Chapel Hill	1267	625	642
US Military Academy	1268	627	641
Trinity College (CT)	1272	630	642
Grove City College	1272	633	639
University of Illinois, Urbana-Champaign	1273	613	660
St. Olaf College	1274	639	635
Mount Holyoke College	1278	651	627
Worcester Polytechnic Institute	1280	620	660
Trinity University	1280	630	650
Boston University	1281	634	647
Illinois Institute of Technology	1283	602	681
University of Michigan, Ann Arbor	1283	622	661
Rhodes College	1284	644	640
Lafayette College	1285	620	665
Smith College	1290	660	630
Rose-Hulman Institute of Technology	1300	620	680
Scripps College	1307	666	641
Rensselaer Polytechnic Institute	1310	626	684
Connecticut College	1310	660	650
Bryn Mawr College	1310	672	638
Whitman College	1314	659	655
University of Virginia	1315	647	668
Davidson College	1315	659	656
Colgate University	1317	652	665
Wheaton College (IL)	1319	661	658
St. John Fisher College	1320	700	620
Tulane University	1327	668	659
Barnard College	1330	660	670
Colby College	1330	660	670
New College of Florida	1330	693	637
University of Southern California	1335	652	683
College of William and Mary	1335	669	666

College	SAT M&CR	SAT M	SAT CR
New York University	1338	672	666
Wellesley College	1342	671	671
Kenyon College	1342	681	661
University of Notre Dame	1350	665	685
Oberlin College	1350	691	659
University of Rochester	1352	665	687
Grinnell College	1352	682	670
Macalester College	1360	690	670
Carnegie Mellon University	1362	646	716
Cornell University	1367	667	700
Reed College	1371	667	704
Johns Hopkins University	1374	671	703
Northwestern University	1378	675	703
Brown University	1390	690	700
Claremont McKenna College	1390	690	700
Wesleyan University	1390	700	690
Williams College	1395	701	694
University of Pennsylvania	1404	688	716
Middlebury College	1410	710	700
Dartmouth College	1415	702	713
Amherst College	1417	710	707
Pomona College	1450	730	720
Massachusetts Institute of Technology	1469	712	757