



**NAVAL  
POSTGRADUATE  
SCHOOL**

**MONTEREY, CALIFORNIA**

**THESIS**

**AN INVESTIGATION OF THE EFFECTIVENESS OF  
SOLAR POWER ON NAVY SURFACE COMBATANTS**

by

Justin P. Kirkpatrick

September 2013

Thesis Advisor:  
Second Reader:

Sherif Michael  
Daniel Nussbaum

**Approved for public release: distribution unlimited**

THIS PAGE INTENTIONALLY LEFT BLANK

<b>REPORT DOCUMENTATION PAGE</b>			<i>Form Approved OMB No. 0704-0188</i>	
Public reporting burden for this collection of information is estimated to average 1 hour per response, including the time for reviewing instruction, searching existing data sources, gathering and maintaining the data needed, and completing and reviewing the collection of information. Send comments regarding this burden estimate or any other aspect of this collection of information, including suggestions for reducing this burden, to Washington headquarters Services, Directorate for Information Operations and Reports, 1215 Jefferson Davis Highway, Suite 1204, Arlington, VA 22202-4302, and to the Office of Management and Budget, Paperwork Reduction Project (0704-0188) Washington DC 20503.				
<b>1. AGENCY USE ONLY (Leave blank)</b>		<b>2. REPORT DATE</b> September 2013	<b>3. REPORT TYPE AND DATES COVERED</b> Master's Thesis	
<b>4. TITLE AND SUBTITLE</b> AN INVESTIGATION OF THE EFFECTIVENESS OF SOLAR POWER ON NAVY SURFACE COMBATANTS			<b>5. FUNDING NUMBERS</b>	
<b>6. AUTHOR(S)</b> Justin P. Kirkpatrick				
<b>7. PERFORMING ORGANIZATION NAME(S) AND ADDRESS(ES)</b> Naval Postgraduate School Monterey, CA 93943-5000			<b>8. PERFORMING ORGANIZATION REPORT NUMBER</b>	
<b>9. SPONSORING /MONITORING AGENCY NAME(S) AND ADDRESS(ES)</b> N/A			<b>10. SPONSORING/MONITORING AGENCY REPORT NUMBER</b>	
<b>11. SUPPLEMENTARY NOTES</b> The views expressed in this thesis are those of the author and do not reflect the official policy or position of the Department of Defense or the U.S. government. IRB protocol number ___N/A___.				
<b>12a. DISTRIBUTION / AVAILABILITY STATEMENT</b> Approved for public release: distribution unlimited			<b>12b. DISTRIBUTION CODE</b> A	
<b>13. ABSTRACT (maximum 200 words)</b> With energy consumption and environmental concerns taking the forefront in this nation, the United States Navy is playing its part by committing itself to reduce its reliance on fossil fuels both at sea and ashore. Solar power is one method by which the Navy can help reach its energy goals. The practicality of equipping its surface combatants with solar panels to aid in the generation of shipboard power in order to reduce the consumption of traditional fossil fuels is examined in this thesis. Such a measure would be beneficial both at sea and in port, for the sun does not discriminate where it shines. In order to accomplish this, research was done into the available surface area associated with various ship classes, current fuel and energy consumption figures both at sea and in port, estimates of how much fuel and money could be saved, what effect the panels will have on tactical factors, and different means of storing the energy generated from the panels.				
<b>14. SUBJECT TERMS</b> Solar power, navy surface combatants, energy storage, tactical feasibility.			<b>15. NUMBER OF PAGES</b> 91	
			<b>16. PRICE CODE</b>	
<b>17. SECURITY CLASSIFICATION OF REPORT</b> Unclassified	<b>18. SECURITY CLASSIFICATION OF THIS PAGE</b> Unclassified	<b>19. SECURITY CLASSIFICATION OF ABSTRACT</b> Unclassified	<b>20. LIMITATION OF ABSTRACT</b> UU	

THIS PAGE INTENTIONALLY LEFT BLANK

**Approved for public release: distribution unlimited**

**AN INVESTIGATION OF THE EFFECTIVENESS OF SOLAR POWER ON  
NAVY SURFACE COMBATANTS**

Justin P. Kirkpatrick  
Lieutenant, United States Navy  
B.S., United States Naval Academy, 2006

Submitted in partial fulfillment of the  
requirements for the degree of

**MASTER OF SCIENCE IN ELECTRICAL ENGINEERING**

from the

**NAVAL POSTGRADUATE SCHOOL  
September 2013**

Author: Justin P. Kirkpatrick

Approved by: Sherif Michael, PhD.  
Thesis Advisor

Daniel Nussbaum, PhD.  
Second Reader

Clark Robertson, PhD.  
Chair, Department of Electrical Engineering  
Graduate School of Engineering and Applied Science

THIS PAGE INTENTIONALLY LEFT BLANK

## **ABSTRACT**

With energy consumption and environmental concerns taking the forefront in this nation, the United States Navy is playing its part by committing itself to reduce its reliance on fossil fuels both at sea and ashore. Solar power is one method by which the Navy can help reach its energy goals. The practicality of equipping its surface combatants with solar panels to aid in the generation of shipboard power in order to reduce the consumption of traditional fossil fuels is examined in this thesis. Such a measure would be beneficial both at sea and in port, for the sun does not discriminate where it shines. In order to accomplish this, research was done into the available surface area associated with various ship classes, current fuel and energy consumption figures both at sea and in port, estimates of how much fuel and money could be saved, what effect the panels will have on tactical factors, and different means of storing the energy generated from the panels.

THIS PAGE INTENTIONALLY LEFT BLANK

# TABLE OF CONTENTS

<b>I.</b>	<b>INTRODUCTION.....</b>	<b>1</b>
<b>A.</b>	<b>PROBLEM STATEMENT .....</b>	<b>1</b>
	1. Operational Practicality .....	1
	2. Energy Storage .....	2
	3. Tactical Feasibility .....	2
<b>B.</b>	<b>PRIOR RESEARCH AND IMPLEMENTATION.....</b>	<b>2</b>
<b>C.</b>	<b>METHODOLOGY AND THESIS STRUCTURE.....</b>	<b>5</b>
	1. Thesis Structure .....	5
	2. Methodology .....	5
<b>II.</b>	<b>SOLAR CELL BACKGROUND.....</b>	<b>7</b>
<b>A.</b>	<b>THE BASICS.....</b>	<b>7</b>
<b>B.</b>	<b>THE ELECTROMAGNETIC SPECTRUM AND SOLAR RADIATION .....</b>	<b>7</b>
	1. Electromagnetic Waves .....	7
	2. Solar Radiation and Air Mass .....	9
<b>C.</b>	<b>THEORY AND OPERATION .....</b>	<b>12</b>
	1. Theory .....	12
	2. Solar Cell Operation .....	12
	3. Efficiency and Other Factors Affecting Operation.....	14
<b>D.</b>	<b>THIN FILM SOLAR CELLS.....</b>	<b>15</b>
<b>III.</b>	<b>OPERATIONAL PRACTICALITY.....</b>	<b>23</b>
<b>A.</b>	<b>IS THERE ENOUGH SURFACE AREA?.....</b>	<b>23</b>
<b>B.</b>	<b>CURRENT FUEL / ENERGY CONSUMPTION .....</b>	<b>25</b>
	1. In-Port Consumption.....	25
	2. At-Sea Consumption.....	27
<b>C.</b>	<b>USAGE AND FINANCIAL EFFECT OF SOLAR ARRAYS.....</b>	<b>27</b>
	1. Geographic Solar Power Production .....	28
	2. Solar Power Capacity of Surface Combatants.....	29
	3. Real World Savings and Cost .....	31
<b>D.</b>	<b>SOLAR PANEL DURABILITY.....</b>	<b>35</b>
<b>E.</b>	<b>OPERATIONAL CONCLUSIONS .....</b>	<b>35</b>
<b>IV.</b>	<b>ENERGY STORAGE.....</b>	<b>37</b>
<b>A.</b>	<b>BATTERIES.....</b>	<b>37</b>
	1. History and Operation.....	37
	2. Applicability .....	39
<b>B.</b>	<b>FLYWHEELS .....</b>	<b>40</b>
	1. History and Operation.....	40
	2. The Modern Flywheel.....	41
	3. Applicability .....	42
<b>C.</b>	<b>FUEL CELLS.....</b>	<b>44</b>
	1. History and Operation.....	44

2.	<b>Applicability .....</b>	<b>46</b>
<b>D.</b>	<b>COMPARISONS AND CONCLUSIONS .....</b>	<b>48</b>
<b>V.</b>	<b>TACTICAL FEASIBILITY.....</b>	<b>51</b>
<b>A.</b>	<b>IMPORTANCE.....</b>	<b>51</b>
<b>B.</b>	<b>RCS AND REFLECTIVITY .....</b>	<b>51</b>
1.	<b>RCS Testing Methodology .....</b>	<b>51</b>
2.	<b>C-Band Testing.....</b>	<b>52</b>
3.	<b>X-Band Testing.....</b>	<b>55</b>
4.	<b>RCS and Reflectivity Conclusions.....</b>	<b>59</b>
<b>C.</b>	<b>IR SIGNATURE PERFORMANCE.....</b>	<b>59</b>
1.	<b>Methodology and Testing.....</b>	<b>59</b>
2.	<b>IR Signature Conclusions.....</b>	<b>61</b>
<b>D.</b>	<b>TACTICAL FEASIBILITY CONCLUSIONS .....</b>	<b>61</b>
<b>VI.</b>	<b>CONCLUSIONS AND RECOMMENDATIONS.....</b>	<b>63</b>
<b>A.</b>	<b>CONCLUSIONS .....</b>	<b>63</b>
<b>B.</b>	<b>RECOMMENDATIONS FOR FUTURE WORK.....</b>	<b>64</b>
	<b>LIST OF REFERENCES .....</b>	<b>65</b>
	<b>INITIAL DISTRIBUTION LIST .....</b>	<b>69</b>

## LIST OF FIGURES

Figure 1.	M/V <i>Auriga Leader</i> of the NYK Shipping Line. From [2].....	3
Figure 2.	The completely solar-powered yacht <i>TURANOR PlanetSolar</i> . From [3].....	4
Figure 3.	The EM Spectrum with the visible light band expanded. From [7].....	8
Figure 4.	The EM spectrum with associated wavelengths and photon energies. From [7] .....	9
Figure 5.	A depiction of the solar radiation spectrum at the top of the atmosphere and at sea level, by wavelength. From [9] .....	10
Figure 6.	Solar cell equivalent circuit. From [11] .....	12
Figure 7.	I-V curve of an illuminated solar cell. From [11].....	14
Figure 8.	The effects of temperature on the I-V curve of a solar cell. From [11].....	15
Figure 9.	CIGS cell illustrating flexibility and very small thickness. From [13].....	16
Figure 10.	Illustration of the cross-section of a typical CIGS cell. From [12].....	17
Figure 11.	Efficiency gains over time by solar cell type. From [14] .....	18
Figure 12.	Constructed CIGS solar cell array. ....	19
Figure 13.	I-V Curve of the constructed CIGS solar cell array.....	20
Figure 14.	LCS-1 <i>Freedom</i> class. From [16] .....	23
Figure 15.	LCS-2 <i>Independence</i> Class. From [16].....	24
Figure 16.	LPD-17 <i>San Antonio</i> class. From [16].....	24
Figure 17.	LHD-1 <i>Wasp</i> class. From [16] .....	24
Figure 18.	Geographic representation of bright sunshine received annually. From [9]...28	28
Figure 19.	Annual sunlight coverage for the U.S. in kWh/m <sup>2</sup> /day of input power. From [9] .....	29
Figure 20.	Illustration of a generic Lithium-Ion battery showing major components. From [12] .....	38
Figure 21.	The NASA G2 experimental flywheel: capable of speeds up to 60,000 RPM. From [12].....	42
Figure 22.	A schematic representation of a single cell in a proton-exchange membrane fuel cell, showing major components. From [12] .....	45
Figure 23.	Depiction of a generic regenerative fuel cell system. ....	47
Figure 24.	Raised solar array on an aluminum plate in the C-band. ....	52
Figure 25.	Solar array flush on an aluminum plate in the C-band. ....	53
Figure 26.	Raised solar array on an angled aluminum plate in the C-band. ....	54
Figure 27.	Solar array flush on an angled aluminum plate in the C-band.....	55
Figure 28.	Raised solar array on an aluminum plate in the X-band. ....	56
Figure 29.	Solar array flush on an aluminum plate in the X-band. ....	57
Figure 30.	Raised solar array on an angled aluminum plate in the X-band. ....	58
Figure 31.	Solar array flush to an angled aluminum plate in the X-band. ....	58
Figure 32.	Comparison of aluminum plate with a solar array (left) to a bare aluminum plate (right) using a “white hot” setting. ....	60
Figure 33.	Comparison of a bare steel plate (left) with a steel plate with a solar array (right), using a “white hot” setting.....	61

THIS PAGE INTENTIONALLY LEFT BLANK

## LIST OF TABLES

Table 1.	A sampling of AM coefficients and solar intensities at the Earth’s surface for various zenith angles. ....	11
Table 2.	Electrical characteristics of the various SP3L solar panels offered by SoloPower. From [15].....	21
Table 3.	Dimensions and calculated surface area for selected warship classes.....	25
Table 4.	In-port average fuel usage figures for various ship types. From [17].....	26
Table 5.	In-port electrical usage and cost averages for various ship types. From [19].....	26
Table 6.	Approximate fuel consumption values for selected ship types. From [20] ....	27
Table 7.	Average solar illumination figures for surface combatants .....	30
Table 8.	Yearly power generation figures for a Pacific Fleet ship. ....	31
Table 9.	Cost to outfit solar panels to various ship types. ....	32
Table 10.	Weight added and percent change in displacement due to adding solar panels on various warship types. ....	33
Table 11.	Estimated in-port savings due to solar panels.....	33
Table 12.	Daily and yearly fuel savings (approx.).....	34
Table 13.	Comparison of common rechargeable batteries with pertinent electrical characteristics. From [24] .....	40
Table 14.	List of run times for various flywheel / output power rating combinations. From [27] .....	43
Table 15.	Different types of fuel cells with pertinent operating data and typical application. From [12] .....	46
Table 16.	Energy output comparison of energy storage devices. From [12].....	48

THIS PAGE INTENTIONALLY LEFT BLANK

## LIST OF ACRONYMS AND ABBREVIATIONS

AM	Air Mass
C	Celsius
DC	Direct Current
EM	Electromagnetic
eV	Electron-volt
IR	Infrared
kW	Kilowatt
LCS	Littoral Combat Ship
LHD	Amphibious Assault Ship
LPD	Amphibious Transport Dock
M/V	Motor Vessel
MW	Megawatt
MWh	Megawatt-hour
NYK	Nippon Yusen Kaisha
RCS	Radar Cross-section
RPM	Revolutions per minute
Si	Silicon
UPS	Uninterruptible Power Supply
UV	Ultraviolet
W	Watt

THIS PAGE INTENTIONALLY LEFT BLANK

## EXECUTIVE SUMMARY

With a growing spotlight being placed on energy consumption and its environmental impact, the Navy has taken steps to reduce its dependence on fossil fuels. Many of these steps were laid out by Secretary of the Navy Ray Mabus in his “Great Green Fleet” initiative [1]. In general terms, they speak to reducing the need for traditional fossil fuels both at sea and at shore-side installations. The impact that solar power can have on the sea-going surface combatants of the Navy and whether solar power is a practical and tactically feasible option for aiding the reduction of fossil fuel consumption is researched in this thesis.

In order to accomplish this goal, many different areas were researched. While utilizing solar power ashore is a simple matter of optimizing sunlight and available surface area, it is a much tougher proposition at sea where the Navy’s fighting ships are required to operate in harsh conditions and possibly go into harm’s way. They must be free of anything that hinders their ability to perform their primary missions; therefore, any additional energy generated via solar power has to have a minimum impact on the ship’s displacement, speed, etc., as well as her detectability.

As mentioned above, generating solar power ashore is a simple matter of finding enough surface area to generate the desire power. On board a ship that is optimized for its mission, this is much tougher. Therefore, surface area must be found without altering the layout of the ship. Four different common ship types were examined, and all were found to possess sufficient surface area with values ranging from approximately 2500 m<sup>2</sup> on the Littoral Combat Ship *Freedom* to 7500 m<sup>2</sup> on the Amphibious Transport Dock *San Antonio*. Assuming a 50 percent array coverage, a 13 percent array efficiency, and a solar intensity of 1 kW/m<sup>2</sup>, output powers in the 100s of kW/hour are achievable. This is a substantial amount of power.

Once this power is generated, two options are available for its use. It must either be used as it is being made or stored for later use. The ideal configuration would be pairing the solar panels with a large capacity energy storage device to allow for energy

usage during hours of sunlight as well as hours of night or in an emergency. Three methods of energy storage were considered: batteries, flywheels, and fuel cells. Flywheels were ruled out due to their short available discharge times, which are on the order of minutes, not hours. The competition between batteries and fuel cells was close, with each type of having advantages and disadvantages. Fuel cells have a higher energy density than batteries, but the Navy has decades of experience operating large storage batteries at sea. Fuel cells require fuel (typically hydrogen), which must be either stored or created, while batteries theoretically require no such fuel. In the end, however, fuel cells appear to be the better option based on their higher energy density and their ability to generate byproducts (water) which can serve other functions aboard ship: cooling, plumbing, etc.

The purpose of generating power via solar panels is to reduce the amount of traditional fossil fuels needed to provide a similar amount of power. Using fuel consumption figures provided by Navy officials, we determined that solar-generated power could save the Navy tens of thousands of gallons of fuel per ship per year as well as hundreds of thousands of dollars per year in fuel and electricity costs. Additionally, the Navy can reduce its carbon footprint by hundreds of metric tons per ship per year.

The ability to generate usable amounts of power is important, but if that generated power comes at the cost of compromising the ship, than it is a non-starter. To determine the effect that solar panels would have on the skin of the ship, a series of experiments were designed to test for radar reflectivity as well as infrared (IR) signature. The radar reflectivity tests involved testing the reflectivity of a bare metal plate at various frequencies common in military applications to determine a baseline. A solar panel was then affixed to the bare metal plate in both a raised and a flush configuration. The panel was then subjected to the same frequencies, and its radar reflectivity difference was then determined as compared to the baseline metal plate. For most of the frequencies and configurations, the reflectivity increased a number of decibels, but not by a significant margin. Overall, the effect of the solar panels was judged to be moderate at worst and was not considered to have a major impact on overall ship's detectability. As for the IR signature of the solar panels, this was determined by placing a solar panel on a metal

plate, laying it in the sun next to a bare plate of like material, and then comparing the two with an IR camera. As expected, the solar panel showed a significantly hotter IR signature. While this has the potential to increase a ship's detectability, it must be looked at in the big picture. A ship must be within visual range of an IR camera for this to have a negative effect. This range is typically much closer than radar range. Therefore, the overall impact on a ship's detectability was determined to be moderate enough that it would not have an adverse effect on her ability to accomplish her missions.

In conclusion, it was shown that for a marginal increase in weight and detectability, a significant impact can be made on fuel consumption and energy generation per ship. Multiply this impact over whole classes of ships, and the overall savings in fuel and money can be significant. In addition, this could cause a measureable reduction in the Navy's environmental impact, especially since solar power can be generated both when the ships are at sea or in port, for the sun shines regardless of ship location.

## **LIST OF REFERNCES**

- [1] P. Ewing, "SecNav: Cut Half of Oil Use by 2020." *Navy Times*. October 14, 2009.

THIS PAGE INTENTIONALLY LEFT BLANK

plate, laying it in the sun next to a bare plate of like material, and then comparing the two with an IR camera. As expected, the solar panel showed a significantly hotter IR signature. While this has the potential to increase a ship's detectability, it must be looked at in the big picture. A ship must be within visual range of an IR camera for this to have a negative effect. This range is typically much closer than radar range. Therefore, the overall impact on a ship's detectability was determined to be moderate enough that it would not have an adverse effect on her ability to accomplish her missions.

In conclusion, it was shown that for a marginal increase in weight and detectability, a significant impact can be made on fuel consumption and energy generation per ship. Multiply this impact over whole classes of ships, and the overall savings in fuel and money can be significant. In addition, this could cause a measureable reduction in the Navy's environmental impact, especially since solar power can be generated both when the ships are at sea or in port, for the sun shines regardless of ship location.

## **LIST OF REFERENCES**

- [1] P. Ewing, "SecNav: Cut Half of Oil Use by 2020." *Navy Times*. October 14, 2009.

THIS PAGE INTENTIONALLY LEFT BLANK

# I. INTRODUCTION

## A. PROBLEM STATEMENT

During the past decades, there have been many advances in the technology of solar power. This form of “green” energy is currently being utilized in housing, corporate construction, and by the Navy on its shore installations. This allows the Navy to generate some of its own power without having to draw from the national electrical grid; this should theoretically save the Navy money while reducing its carbon footprint.

Why not take this technology a step further and utilize solar power on the Navy’s Surface vessels? This step could have the potential to lower operating costs, lower fuel consumption, and provide an additional source of stored energy in an at-sea or in-port emergency. These are all stated goals of the “Great Green Fleet” initiative as set forth by the Honorable Ray Mabus, Secretary of the Navy, in his October, 2009 address to the Naval Energy Forum [1].

Many topics that relate directly to the “problem” of whether solar energy is operationally viable and tactically feasible on board the Navy’s surface combatants are examined in this thesis. Some of these topics include survivability, energy storage, and effect on over-all ship’s radar cross-section (RCS).

### 1. Operational Practicality

The first area to be examined involves the practicality of such a step (i.e., is there enough un-used surface area on surface ships to provide enough real-estate to generate sufficient power.) This is determined by utilizing both line drawings and dimensions to calculate conservative estimates of usable surface area and then coupling the result with current solar cell efficiency ratings per given area to arrive at an estimated power output. This result is then manipulated to show what the daily, monthly, and yearly power outputs could be per ship class, which will then be used to show how much fuel and money could be saved over the course of a similar period of time.

Additional research will be undertaken to determine if the Solar Panels can survive the harsh environment that defines the high seas and what steps need to be taken to ensure their reliable long-term operation. Detail concerning the array's physical strength, as well as its ability to be shielded from the corrosiveness of salt water, is considered.

## **2. Energy Storage**

Research was conducted to determine a range of energy storage options. With daily energy generation expected to be in the kW–MW range, a large energy storage capacity is needed in conjunction with this system. Multiple options are discussed, including battery and flywheel technologies.

Besides the pros and cons of each storage option researched, the physical characteristics of each is also examined. This examination includes both size and weight, as both are in high demand on board a modern warship.

## **3. Tactical Feasibility**

The Navy is, by definition, a sea-going combat service. Tactical security and flexibility are important parts of what makes the Navy successful. Many missions demand that a ship lower its detectability as much as possible. Two aspects of this detectability are a ship's RCS and infrared (IR) signature. Research is conducted to determine what, if any, effect the addition of solar arrays has on these two important detection characteristics. This is done by analyzing solar arrays in multiple frequency bands common to military radars and comparing those results to bare metal analyzed in the same bands. Additionally, an array will be placed outside and examined using IR imagery to determine what type of IR signature it possesses.

## **B. PRIOR RESEARCH AND IMPLEMENTATION**

While much work has been done in the field of solar cells for applications on land and in space, the volume of research conducted in the field of maritime applications pales in comparison. Solar cells have been used to provide power to landed electrical grids for decades. Similarly, solar arrays have been used in satellite and space station designs for

years as well. It was not until recently that large scale work began in the field of maritime solar array usage.

While solar cells have been used on board smaller personal craft and ferries for many years, it was not until 2009 that the first ocean-going vessel deployed with a large number of solar cells [2]. That vessel, shown in Figure 1, was the M/V *Auriga Leader*, an experimental car-carrier built and operated by the Nippon Yusen Kaisha (NYK) Shipping Line.



Figure 1. M/V *Auriga Leader* of the NYK Shipping Line. From [2]

While she is a large vessel at almost 200 m in length, she was only fitted with a 250 m<sup>2</sup> solar array for a maximum output of 40 kW. [2] Upon completion of her first two years at sea, the *Auriga Leader* had generated 57 MWh a year, saved NYK 13 tons of fuel a year, and achieved a CO<sub>2</sub> emissions reduction of 40 tons a year [2]. In addition to the tangible results, the line also gained experience operating this system at sea and reported no major problems with regards to inclement weather or sea conditions. They also discovered a number of benefits to operating solar arrays at sea vice land (Tokyo), including increased array cooling efficiency due wind cooling, longer daylight hours, and higher sun altitude and stronger sunlight [2].

In a similar vein, the world's largest solar-powered boat completed the first circumnavigation of the globe completely on solar power last year. [3] The privately funded yacht *TURANOR PlanetSolar* is equipped with over 500 m<sup>2</sup> of solar panels which power two electric motors, capable of propelling the yacht at speeds up to 14 knots. The yacht, pictured in Figure 2, completed the journey in just over 19 months.



Figure 2. The completely solar-powered yacht *TURANOR PlanetSolar*. From [3]

Further current maritime applications for solar arrays can be found in the world of un-manned underwater vehicles and gliders. In this field, solar panels are utilized to provide power for on-board processing, communication and various payloads. For instance, the Liquid Robotics SHARC SV2 can generate a peak power of 112 W with mission lengths exceeding a year [4]. This ability to generate on-board, continuous power is extremely valuable for vehicles that rely on compact size in order to accomplish a wide range of missions, many of which demand stealth.

While many theses have been completed researching space, land, and un-manned aerial vehicle applications of solar arrays, no theses were found specifically in the maritime application of solar arrays on surface ships. While this prior research has some application to the problem at hand, the ocean environment is unique and harsh in its own

peculiar way and offers its own challenges that have not been covered in any previous work. The work of the NYK line into commercial maritime application is very relevant and demonstrates a forward-thinking vision of the possible. It also provides a useful data point on what is possible, even with a relatively modest solar array.

## **C. METHODOLOGY AND THESIS STRUCTURE**

As stated above, many topics are covered in this thesis. It is, therefore, logical to lay out the method and structure of the thesis.

### **1. Thesis Structure**

Following the introductory chapter, all background information including the basic theory and operation of solar cells as well as any pertinent equations needed are covered in Chapter II. All operational considerations including the amount of usable surface area, current fuel and energy consumption figures, potential energy generation and fuel/money savings, and solar panel survivability are covered in Chapter III. A range of energy storage methods and their respective suitability for ship-board use is then covered in Chapter IV. The tactical feasibility of utilizing solar panels on warships is covered in Chapter V. Finally, all conclusions and recommendations are included in Chapter VI.

### **2. Methodology**

Due to the wide range of areas researched, the methods utilized were disparate. Physical research was utilized where possible, especially in the section regarding tactical feasibility. In other areas of the thesis, including practical and operational areas, more theoretical research was utilized. Additionally, areas where more hands-on, full-scale research can be conducted in the future are identified.

THIS PAGE INTENTIONALLY LEFT BLANK

## II. SOLAR CELL BACKGROUND

Before proceeding to research, findings, and results, it is important to have a fundamental knowledge of the subject at hand. With that in mind, the basics of solar cell theory, construction, and operation, as well as any pertinent equations, figures and tables needed to understand the subject matter are covered in the following sections.

### A. THE BASICS

A solar cell (or photovoltaic cell) is merely an electrical device that converts energy from light directly into electricity using the photovoltaic effect [5]. More precisely, it is basically a p-n junction in which light energy generates electron-hole pairs, which subsequently causes current to flow [6]. The cell's electrical characteristics (I, V, and R) vary depending on the strength of the light incident upon it. When exposed to light, the solar cell can generate and maintain electrical current without the need of any external voltage source. There are three basic attributes of a functioning solar cell [5]:

- The absorption of incident light generates electron-hole pairs.
- Charge carriers of opposite type are separated.
- The separated charge carriers are extracted to an external circuit.

### B. THE ELECTROMAGNETIC SPECTRUM AND SOLAR RADIATION

#### 1. Electromagnetic Waves

Electromagnetic (EM) radiation is a form of energy that is emitted and absorbed by charged particles which exhibit wave-like behavior as the wave travels through space [7]. EM radiation carries energy continuously through space away from its source. The basic unit of this type of radiation is the photon. Additionally, EM waves can be discussed and defined by three variables: frequency ( $f$ ), wavelength ( $\lambda$ ), and photon energy ( $E$ ). The relationship between these physical properties is governed by:

$$E = \frac{hc}{\lambda} \quad (2.1)$$

and

$$f = \frac{c}{\lambda} = \frac{E}{h} \quad (2.2)$$

where  $c$  is the speed of light and  $h$  is Planck's constant ( $4.135 \times 10^{-15}$  eVS). These equations relate the frequency and wavelength of EM radiation to the amount of energy in each photon.

EM radiation is classified by its frequency. This classification forms the EM spectrum and is shown below, in order of decreasing frequency and increasing wavelength:

- Radio waves
- Microwaves
- Infrared radiation
- Visible light
- Ultraviolet (UV) radiation
- X-rays
- Gamma rays

A more detailed illustration of the entire EM spectrum with the visible light portion highlighted is shown in Figure 3.

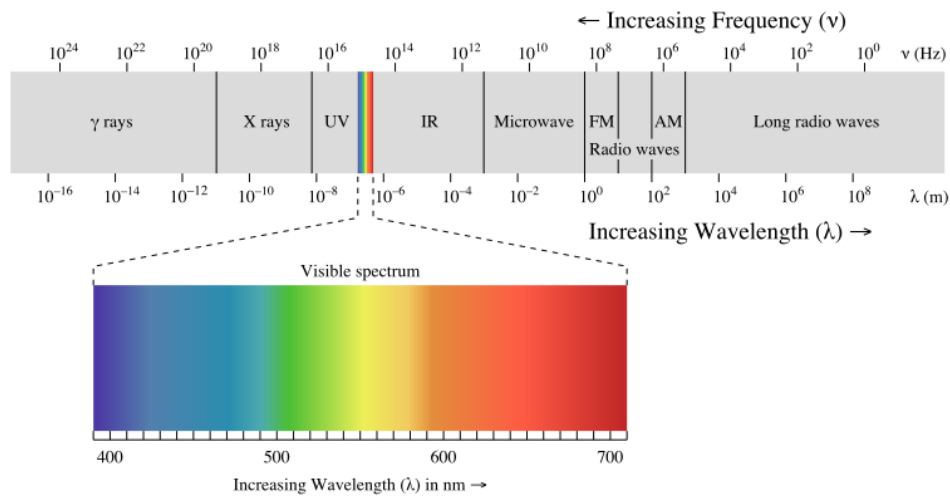

Figure 3. The EM Spectrum with the visible light band expanded. From [7]

The EM spectrum can also be broken down by frequency. In Figure 4, the specific frequencies and photon energies are shown with their respective wavelengths. These figures can be solved for using Equations 2.1 and 2.2.

CLASS	FREQUENCY	WAVELENGTH	ENERGY
Y	300 EHz	1 pm	1.24 MeV
HX	30 EHz	10 pm	124 keV
SX	3 EHz	100 pm	12.4 keV
EUV	300 PHz	1 nm	1.24 keV
NUV	30 PHz	10 nm	124 eV
	3 PHz	100 nm	12.4 eV
NIR	300 THz	1 $\mu$ m	1.24 eV
MIR	30 THz	10 $\mu$ m	124 meV
FIR	3 THz	100 $\mu$ m	12.4 meV
EHF	300 GHz	1 mm	1.24 meV
SHF	30 GHz	1 cm	124 $\mu$ eV
UHF	3 GHz	1 dm	12.4 $\mu$ eV
VHF	300 MHz	1 m	1.24 $\mu$ eV
HF	30 MHz	10 m	124 neV
MF	3 MHz	100 m	12.4 neV
LF	300 kHz	1 km	1.24 neV
VLF	30 kHz	10 km	124 peV
VF/ULF	3 kHz	100 km	12.4 peV
SLF	300 Hz	1 Mm	1.24 peV
ELF	30 Hz	10 Mm	124 feV
	3 Hz	100 Mm	12.4 feV

Figure 4. The EM spectrum with associated wavelengths and photon energies. From [7]

## 2. Solar Radiation and Air Mass

Solar radiation closely matches a black body radiator operating at about 5800 K [8]. In other words, it emits energy across the breadth of the EM spectrum. As the solar radiation passes through the atmosphere, chemical interactions take place and some of the sunlight is absorbed. One example of this is the stripping of ultraviolet light in the upper atmosphere by ozone. Other interactions occur, and by the time the sunlight reaches the Earth's surface, it is confined between the far IR and near UV portions of the EM spectrum. [8] A depiction of these interactions is shown in Figure 5.

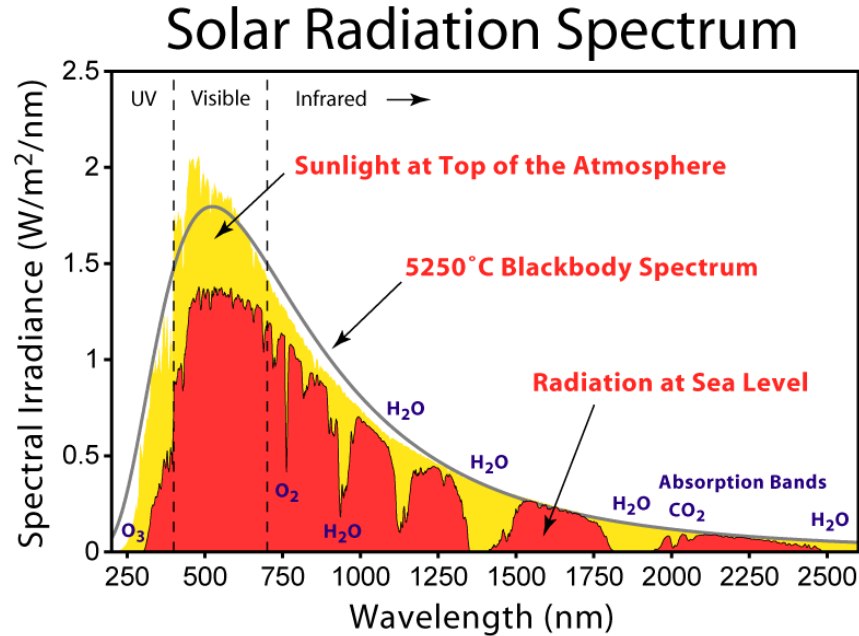

Figure 5. A depiction of the solar radiation spectrum at the top of the atmosphere and at sea level, by wavelength. From [9]

In Figure 5, the yellow shaded area represents sunlight at the top of the atmosphere, while the red shaded area represents sunlight at the earth's surface. The variation due to the chemical interactions is clearly visible. The greater the distance that sunlight travels in the Earth's atmosphere, the more it is attenuated by these various chemical interactions, scattering, and absorption.

This fact is responsible for the existence of the air mass (AM) coefficient, which defines the direct optical path length through the Earth's atmosphere. It is expressed as a ratio of the path length versus the path length vertically upwards and is expressed as

$$AM = \frac{L}{L_o} = \frac{1}{\cos z} \quad (2.3)$$

where  $z$  is the zenith angle in degrees and  $L_o$  is the zenith path length. This is a relatively simplistic representation that does not take into account the curvature of the Earth. A more accurate calculation of the AM coefficient is expressed by [8]

$$AM = \sqrt{(r \cos z)^2 + 2r + 1} - r \cos z \quad (2.4)$$

where  $r$  is the ratio of the Earth's radius to the effective height of the atmosphere and equals approximately 708. [8] Given the resulting AM value from Equation 2.4, the solar intensity at any location can be calculated using

$$I = 1.1I_o0.7^{AM^{0.678}} \quad (2.5)$$

where  $I_o$  is the solar intensity outside the Earth's atmosphere and is  $1353 \text{ W/m}^2$ . By employing both Equations 2.4 and 2.5, various solar intensities can be calculated for any desired zenith angle. A sample of these calculations is included as Table 1.

Table 1. A sampling of AM coefficients and solar intensities at the Earth's surface for various zenith angles.

$z$	AM	$\text{W/m}^2$
0	1	1042
10	1.015	1038
20	1.064	1026
30	1.154	1005
40	1.305	971
48.2	1.5	931
60	2	841
70	2.908	713
80	5.634	470
90	37.643	23

The results displayed in Table 1 are calculated using the ideal case. There are many factors, however, that can change the solar intensity. These factors include photochemical smog, water vapor, aerosols, and the effects of temperature inversion. [8] Additionally, since the AM number is dependent on the path length through the atmosphere, it varies with the time of day, season, and with the latitude of the position at which it is being measured. For instance, San Diego, California sits at approximately  $33^\circ$  N latitude. During the month of July, its zenith angle is approximately  $13^\circ$ , while in the month of January, its zenith angle is approximately  $53^\circ$ . [10] This difference yields a disparity in solar intensity of  $135 \text{ W/m}^2$  when calculated using Equations 4.4 and 4.5. This result only takes into account the change in season, and none of the other effects that have an impact on solar intensity.

## C. THEORY AND OPERATION

### 1. Theory

The theory behind solar cells is relatively simple. Basically, photons in sunlight hit the solar cell and are absorbed by the semi-conducting material, such as Silicon (Si). Electrons are then freed from their respective atoms. This allows them to flow through the material, producing electricity. By tying a large number of cells together into an array, a usable amount of DC electricity is produced [11]. A simple model of a solar cell is shown in Figure 6.

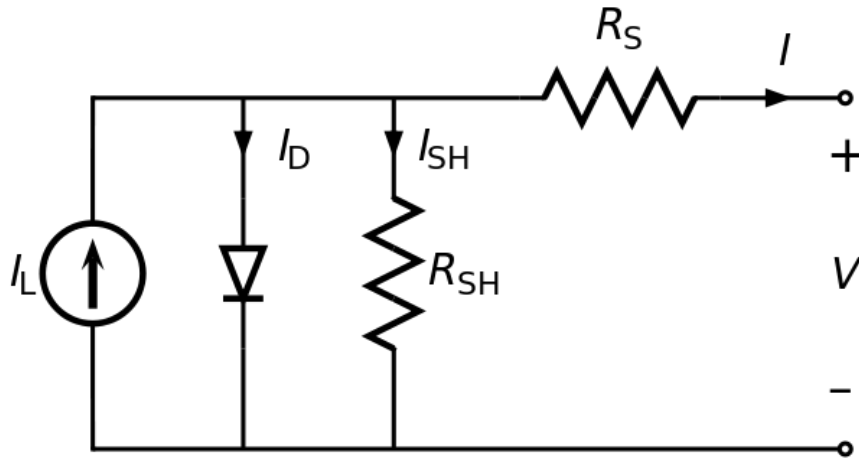

Figure 6. Solar cell equivalent circuit. From [11]

As is shown in Figure 6, the solar cell can be modeled as a current source in parallel with a diode. This represents the fact that due to its construction, current will only flow in one direction. The shunt and series resistors are included to represent the fact that no solar cell is ideal [11].

### 2. Solar Cell Operation

As stated earlier, a solar cell is a p-n junction that happens to be similar in nature to a diode. Silicon, the most commonly used element in the manufacture of semiconductor devices, has four valence electrons. These atoms are thus able to form a stable crystalline structure where the neighboring atoms share their valence electrons in what is called a covalent bond [6]. Thus, the valence electrons are being shared between

two atoms and are not necessarily strictly tied to either. The movement of the valence electrons in the crystal can create free electrons and holes, generating an electric current. This process is heavily dependent on temperature, and as the temperature increases, the amount of charge movement increases. A pure Si crystal has an equal number of free electrons and holes generated by thermal ionization [6]. Doping of the Si can increase either the number of free electrons or holes, depending on the type of material used in the doping process. By doping the Si with an atom that contains five valence electrons, an n-type Si crystal is created that has negatively-charged electrons as the majority of its charge carriers. Four of the five valence electrons of the doping material form covalent bonds with the valence electrons of the Si, leaving the fifth valence electron of the doping material to function as a free electron. Conversely, by doping the Si with an atom that only has three valence electrons, a p-type, or positively-charged, Si crystal is created [6].

Optical absorption in a solar cell involves an electrical transition from a filled state to an empty state. There generally exists an energy threshold below which no photonic absorption will take place. In a semi-conductor, this energy is called the band-gap and is defined as the minimum energy necessary to promote an electron from the valence band of an atom to the conduction band [12]. This value is measured in electronvolts (eV). Si has a band-gap energy of 1.1 eV, which, as shown in Figure 4, is the photon energy of solar radiation in part of the visible light spectrum.

There are a number of characteristics and metrics that describe and affect the operation of a solar cell. The first of these characteristics is the short-circuit current  $I_{sc}$ . This describes the current through the cell when the two terminals of the solar cell are shorted together and is also the maximum amount of current that can pass through the cell. The next important characteristic is the open-circuit voltage  $V_{oc}$ . This describes the voltage across the cell when no current is present and is the maximum amount of voltage that can be present. An I-V curve can be created using these values [12]. This curve is shown in Figure 7.

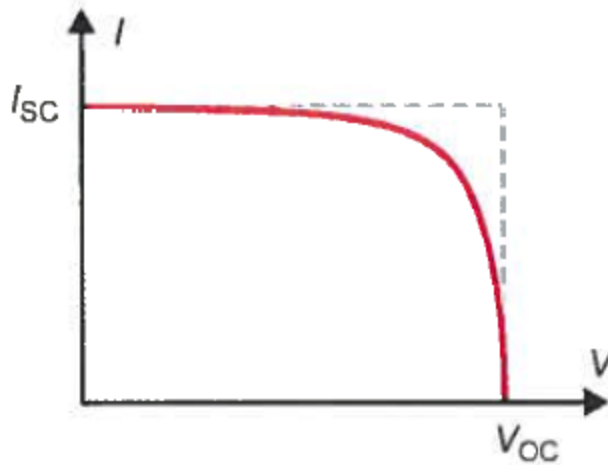

Figure 7. I-V curve of an illuminated solar cell. From [11]

To determine the power produced by the solar cell, the simple equation  $P = IV$  is utilized. As is clearly shown in Figure 7, the power at both  $I_{sc}$  and  $V_{oc}$  is zero. The maximum power  $P_{max}$  occurs on the knee of the I-V curve and is at the point where the equation  $P = IV$  yields the greatest value.

### 3. Efficiency and Other Factors Affecting Operation

There are a number of methods of determining the effectiveness of a solar cell. Those are the fill factor (FF) and the conversion efficiency  $\eta$ . The FF is merely a comparison between the actual power generated and the theoretical power that would be generated if the solar cell were operated at  $I_{sc}$  and  $V_{oc}$  simultaneously. This can be mathematically represented as  $FF = P_{max}/P_t$ , where  $P_t$  is the theoretical power. The higher the FF, the better the solar cell is in terms of electrical power conversion. The conversion efficiency is simply the ratio of the output power  $P_{out}$  to the input power  $P_{in}$  and is defined as  $\eta = P_{out}/P_{in}$ . The maximum efficiency is achieved when the solar cell is operating at its maximum power output point on the I-V curve and is the standard indicator of the performance of the cell [12].

There are a number of factors that can affect the operation of solar cells. One of these factors is temperature. Solar cell efficiencies and parameters are typically measured at a temperature of 25 C, and any deviation has an effect on the cell efficiency.

For Si, the band-gap narrows as temperature increases, which yields a decrease in  $V_{oc}$  with increasing temperature. This phenomenon translates into a decrease in efficiency of 0.5% per C [12], and is illustrated in Figure 8.

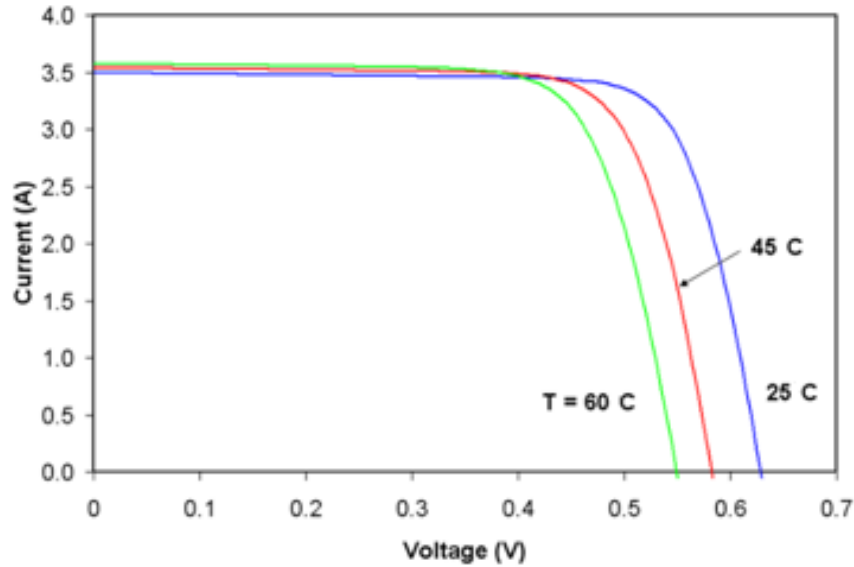

Figure 8. The effects of temperature on the I-V curve of a solar cell. From [11]

Another factor that can affect the operation of the solar cell is the intensity of the sun. Since the maximum amount of current produced is directly related to the amount of photon excitation, as sun intensity decreases, the maximum current value  $I_{sc}$  decreases [12]. This yields a drop in the maximum amount of output power, which causes a drop in the solar cell efficiency. Other factors which can affect the performance of solar cells include damage to the cell itself and any foreign objects or stains on the surface of the cell which obstruct sunlight from reaching the surface of the cell.

#### D. THIN FILM SOLAR CELLS

Traditional Si solar cells are typically large and heavy and encased in glass. However, there is a subset of solar cells emerging that offers the possibility of erasing some of these perceived drawbacks. That subset is the thin film solar cell. As opposed to being cut from bulk Si, the thin film cells are produced by vapor deposition onto a

flexible substrate such as metal foil [12]. This process utilizes large-area production using lower-cost materials but yields a lower efficiency cell when compared to a traditional Si cell.

One of the more common thin film cells is the Copper Indium Gallium Selenide (CIGS) cell, which has demonstrated an efficiency of up to 20 percent in a laboratory setting [12]. Other types of thin film cells utilize Si as well as Cadmium-Telluride. Thin film solar cells operate in the same manner as more traditional cells: absorbing light and allowing the energy of the photon to break an electron free from its covalent bond. However, they are much lighter and thinner than traditional cells, with CIGS cells measuring as little as 4  $\mu\text{m}$  in thickness [12]. Additionally, CIGS cells yield the highest current efficiencies of any thin film solar cells, as well as possessing the highest energy production at varying light conditions [13]. An example of a thin, flexible CIGS cell is shown in Figure 9.

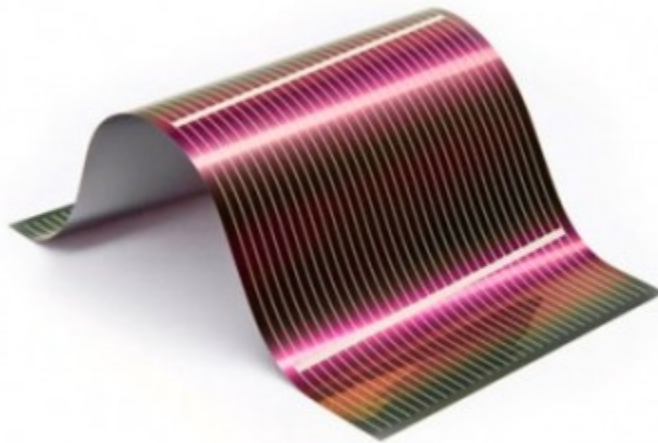

Figure 9. CIGS cell illustrating flexibility and very small thickness. From [13]

A typical CIGS cell cross-section is illustrated in Figure 10. This depiction clearly shows the various layers of the cell. Included are the upper transparent conducting oxide layer (frequently made from Zinc-oxide), the CdS contact layer, the actual CIGS absorption layer, the lower Mo contact layer, and then, finally, the substrate [12]. Many different types of materials can be used for the substrate, including foils, plastics, and glass. The flexibility of the cell is largely dependent on the substrate. As

previously mentioned, one current method of production involves the physical vapor deposition of the material onto a substrate. This method yields the highest-efficiency cells [12].

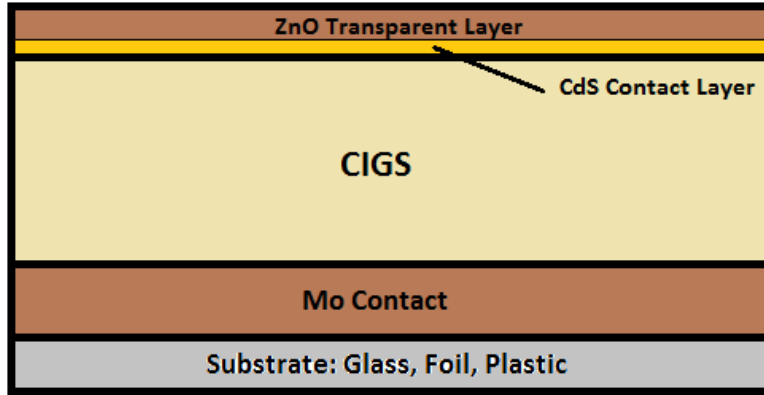

Figure 10. Illustration of the cross-section of a typical CIGS cell. From [12]

A chart showing all relevant solar cell technological achievements in increasing efficiency is displayed in Figure 11. From this figure, it is clear that CIGS (indicated by the solid green circle line) has achieved the highest efficiency of any thin film solar cell, and its current trajectory indicates its efficiency will continue to grow.

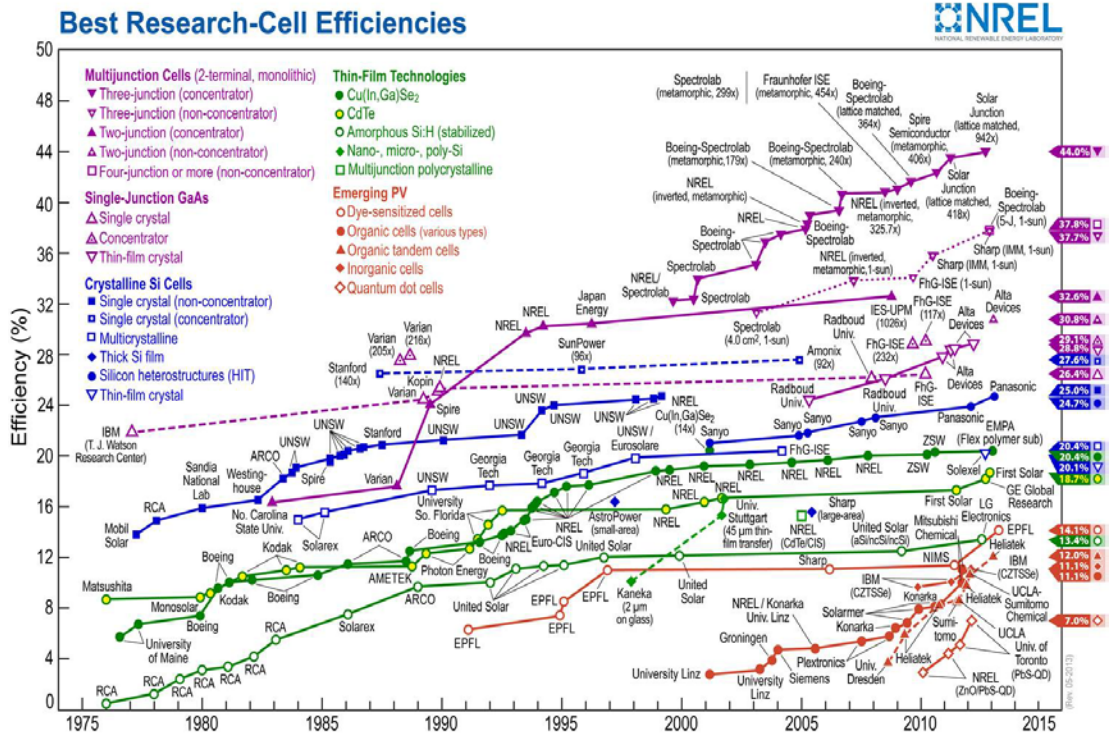

Figure 11. Efficiency gains over time by solar cell type. From [14]

To illustrate the flexibility and lightweight properties of current CIGS technology, a sample solar cell array was constructed and tested. Ten individual bare cells were connected in series to form the array. Each cell measured 99 mm by 209 mm for a total surface area of approximately 0.2 m<sup>2</sup>. The array was affixed to a flexible plastic backing and coated with clear tape to simulate the type of coating a completed commercial array would be equipped with. It weighed approximately three fourths of a pound. The completed array is shown in Figure 12.



Figure 12. Constructed CIGS solar cell array.

This sample array was tested over the course of a number of afternoons in as good of conditions that Monterey, California provides. It was tested both lying flat and at an angled position so as to achieve a perpendicular position relative to the sun. As expected, the angled test produced the highest observed power. The pertinent characteristics were recorded as follows:

- $V_{oc} = 5.76 \text{ V}$
- $I_{sc} = 5.698 \text{ A}$
- $P_{max} = 16.62 \text{ W}$
- $V_{maxp} = 3.529 \text{ V}$
- $I_{maxp} = 4.71 \text{ A}$
- $FF = 0.506$

The resulting I-V curve from this test is included as Figure 13.

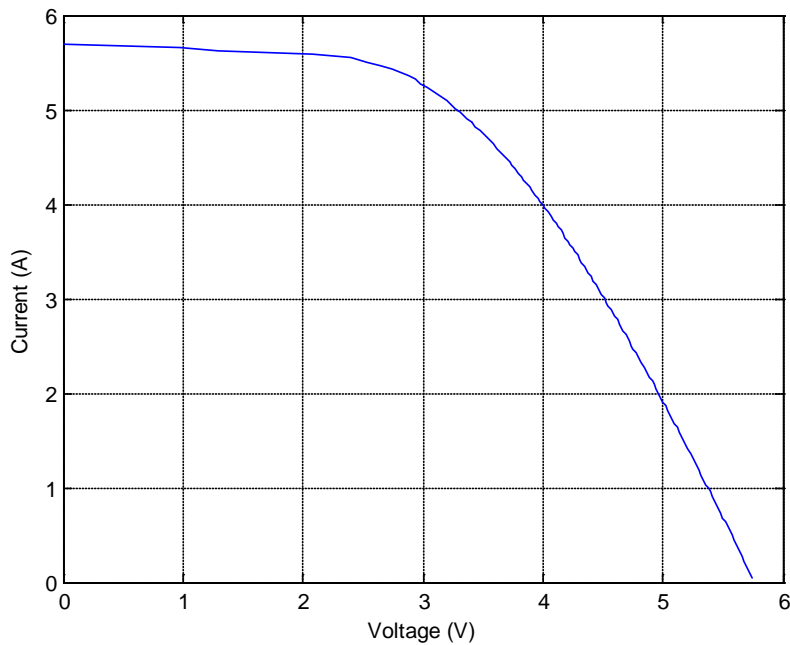

Figure 13. I-V Curve of the constructed CIGS solar cell array.

One example of a current commercially available CIGS cell is the SP3L produced by the company SoloPower. This model, which measures roughly  $2.5 \text{ m}^2$ , comes in various models, and has the following dimensions: [15]

- Length: 86.5"
- Width: 45.1"
- Thickness: 2 mm
- Weight: 13.2 lbs.

At its best efficiency of 13 percent, it can produce an output power of 300 W [15]. The various models along with their respective electrical characteristics are displayed in Table 2. All of the characteristics were determined at standard test conditions which are defined as  $1000 \text{ W/m}^2$  intensity, AM 1.5, and 25 C cell temperature.

Table 2. Electrical characteristics of the various SP3L solar panels offered by SoloPower. From [15]

<b>Solopower SP3L</b>		<b>220</b>	<b>240</b>	<b>260</b>	<b>280</b>	<b>300</b>
Rated Power (Pmax)	W	220	240	260	280	300
Voltage at Pmax (Vmp)	V	65.1	68.2	70.8	77.1	83.6
Current at Pmax (Imp)	A	3.4	3.5	3.7	3.6	3.6
Short-circuit current (Isc)	A	4.4	4.3	4.4	4.2	4.2
Open-circuit Voltage (Voc)	V	91.8	95.4	97.2	102.6	108.0
Efficiency	%	9.5	10.4	11.2	12.1	13.0

For the purposes of this thesis, any calculations involving solar panels will be conducted using the 300 W, 13 percent efficiency cell described above since this is a commercially available product now. In the future, real-world efficiencies will only improve, getting closer and closer to the values achieved in the laboratories.

THIS PAGE INTENTIONALLY LEFT BLANK

### III. OPERATIONAL PRACTICALITY

Now that the basics of solar power have been discussed, it must be determined whether the technology shows any promise with regards to a naval application. In order to do this, a number of factors must be taken into account. In this chapter the operational practicality of utilizing solar cells on board surface combatants are examined. Specifically, it is determined if there is enough usable surface area associated with various ship types as well as what level of fuel / cost savings and energy production can be realized.

#### A. IS THERE ENOUGH SURFACE AREA?

When examining this topic, the entering question must be: “Is there enough surface area?” For this to be operationally viable, there must be enough usable surface area on the hull, decks, and superstructures of a warship to affix solar arrays to. With this in mind, a number of different ship types were examined to determine the usable surface area. In order to determine this surface area, scale drawings were used of each type along with the known dimensions. The major surface areas were then calculated (conservatively) using a combination of drawings and dimensions [16]. The four different warship types analyzed are shown in Figures 14-17.



Figure 14. LCS-1 *Freedom* class. From [16]

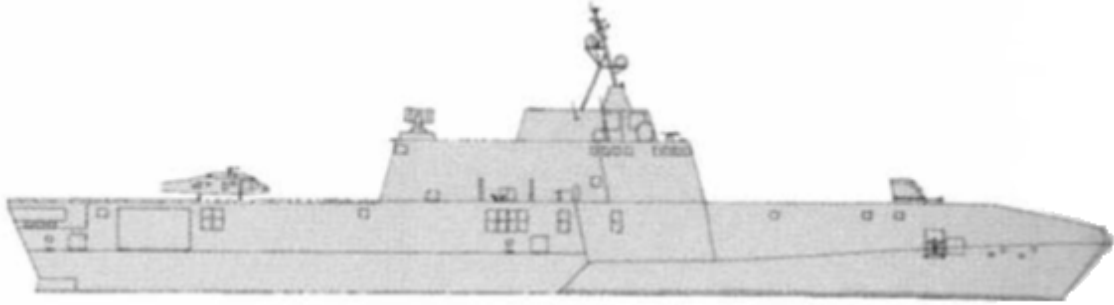

Figure 15. LCS-2 *Independence* Class. From [16]

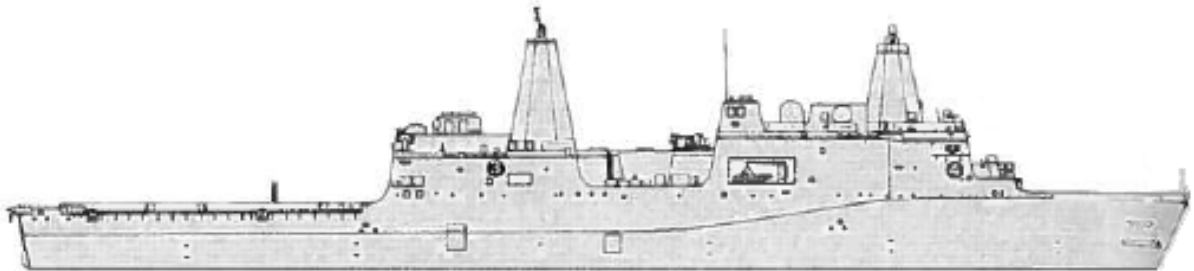

Figure 16. LPD-17 *San Antonio* class. From [16]

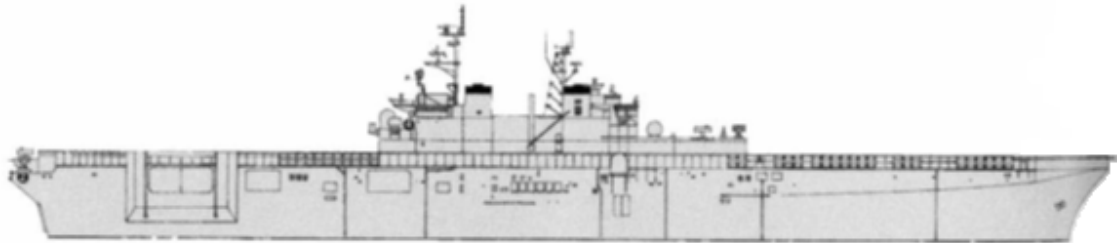

Figure 17. LHD-1 *Wasp* class. From [16]

As was previously stated, the surface area was calculated using Figures 14 – 17 as well as the known dimensions. These surface area totals, along with some pertinent ship data, are included in Table 3.

Table 3. Dimensions and calculated surface area for selected warship classes.

Class	Length (ft.)	Beam (ft.)	Displacement (tons)	Surface Area (m <sup>2</sup> )
LCS-1 <i>Freedom</i>	378'	43'	3,089	2,536.4 m <sup>2</sup>
LCS-2 <i>Independence</i>	417'	103'	2,790	3,310.3 m <sup>2</sup>
LPD-17 <i>San Antonio</i>	683'	104'	25,885	7,561.4 m <sup>2</sup>
LHD-1 <i>Wasp</i>	819'	118'	40,650	4,532.4 m <sup>2</sup>

As is clearly illustrated in Table 3, there is enough usable surface area on multiple classes of warships to make the addition of solar arrays functionally viable. While these figures are conservative in nature, they show the potential for a large power capacity from solar arrays, even given only a 50 percent array illumination.

## **B. CURRENT FUEL / ENERGY CONSUMPTION**

In order to determine the amount of fuel (and money) that could be saved by the inclusion of solar panel arrays, it is important to first know how much fuel and energy is consumed on average by various ship types. More specifically, data must be gathered for both in-port and at-sea situations, since one of the benefits of solar power is that it can be utilized anywhere.

### **1. In-Port Consumption**

When Navy surface combatants are in port, their electrical requirements are less than when they are at sea. Nonetheless, they still require power for lighting, habitability systems, computer systems, and much more. When they are in their homeport, they will “plug in” to the local electrical grid and obtain their power that way. When they are in other ports, they will generally run their electric generators to provide their own electricity. This process burns fuel. Class average fuel usage data was obtained from officials from 3<sup>rd</sup> Fleet in San Diego [17]. In-port fuel usage figures are included in Table 4.

Table 4. In-port average fuel usage figures for various ship types. From [17]

Ship Type	Annual Fuel Usage (barrels)	Cost (est.)
LCS-1 <i>Freedom</i>	2,392	\$303,000
LCS-2 <i>Independence</i>	1,656	\$210,000
LPD-17 <i>San Antonio</i>	4,304	\$546,000
LHD-1 <i>Wasp</i>	15,656	\$1,987,000

From Table 4, it is clear that the cost to power these ships when in port is substantial. The cost figures in Table 4 were estimated using the current price of diesel fuel, [18] but this only represents a portion of the annual cost since the ships utilize shore-power when in their homeport. This shore power data is included in Table 5 [19].

Table 5. In-port electrical usage and cost averages for various ship types. From [19]

Ship Type	Daily Avg. Electrical Usage (MWh)	Daily Cost	Annual Cost (180 days)
LCS-1 <i>Freedom</i>	18.5	\$1,776	\$319,680
LCS-2 <i>Independence</i>	17	\$1,698	\$305,640
LPD-17 <i>San Antonio</i>	81.3	\$8,310	\$1,495,800
LHD-1 <i>Wasp</i>	71.4	\$7,759	\$1,396,620

From Table 5, it is clear that the cost to run ships in port is expensive. The annual cost column was calculated assuming that a ship spent 180 days in home-port. Therefore, the annual cost increases or decreases depending on a ship's operational tempo.

## 2. At-Sea Consumption

When at sea, a ship must generate all her own electricity in order to power machinery, sensors, weapons, air-conditioning units, etc. Typically, the larger the ship and crew, the more electrical power is required. In order to generate this electricity, surface combatants typically employ diesel generators. These machines require a large amount of fuel in order to produce the requisite electricity to keep the ship running. Using data provided by personnel from Expeditionary Strike Group Three in San Diego, CA, we calculated the approximate fuel consumption figures. These figures are included in Table 6.

Table 6. Approximate fuel consumption values for selected ship types. From [20]

<b>Class</b>	<b>GPH Towards Electrical Use (approx.)</b>	<b>Daily Cost (approx.)</b>
LCS-1 <i>Freedom</i>	147	\$10,614.00
LCS-2 <i>Independence</i>	150	\$10,795.00
LPD-17 <i>San Antonio</i>	259	\$18,648.00
LHD-1 <i>Wasp</i>	876	\$63,072.00

From Table 6, it is clear that these ships use a substantial amount of fuel each year. These values are only estimates of the fuel used to generate electricity. When the fuel used for propulsion is factored in, the amount of fuel consumed per year is staggering.

## C. USAGE AND FINANCIAL EFFECT OF SOLAR ARRAYS

Before we discuss the specific impact of solar panels on the fuel and energy consumption values discussed in the previous section, we must first discuss solar power usage in general. Specifically, the ability to generate power in various places on the planet must be discussed as well as the solar power capacity of the various ship classes investigated.

## 1. Geographic Solar Power Production

Based on atmospheric conditions as well as the length of the path that sunlight must travel in the atmosphere, not all locations on the Earth receive the same amount or quality of sunlight as others. A geographic representation of bright sunshine received by location is illustrated in Figure 18.

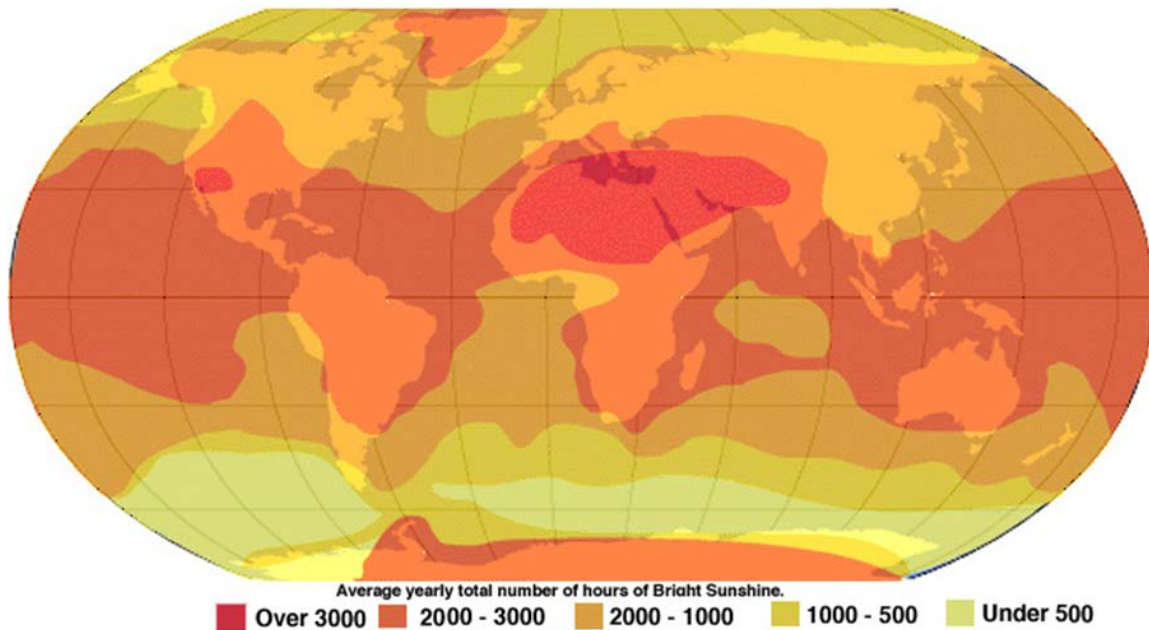

Figure 18. Geographic representation of bright sunshine received annually. From [9]

It is clear from Figure 18 that the optimum locations for solar power generation are around the equator and at the poles. Another thing that is clear is that the majority of the areas in which surface combatants operate throughout the year are in the highest three categories of annual sunlight. The majority of forward navy bases, as well as many ports that surface combatants pull into, are located in the upper two tiers of the sunlight bands. One notable exception to this is Japan, which serves as the home for the U.S. Seventh Fleet. Japanese ports fall in the middle of the middle band of sunlight coverage. While it is important to know sunlight coverage at sea and in foreign ports, it is equally important to understand the sunlight coverage in the U.S. homeports, since ships will spend a large portion of their lives in port or operating in the local areas during training, work-ups, and

exercises. Therefore, a geographic illustration of sunlight coverage in the U.S. is provided in Figure 19.

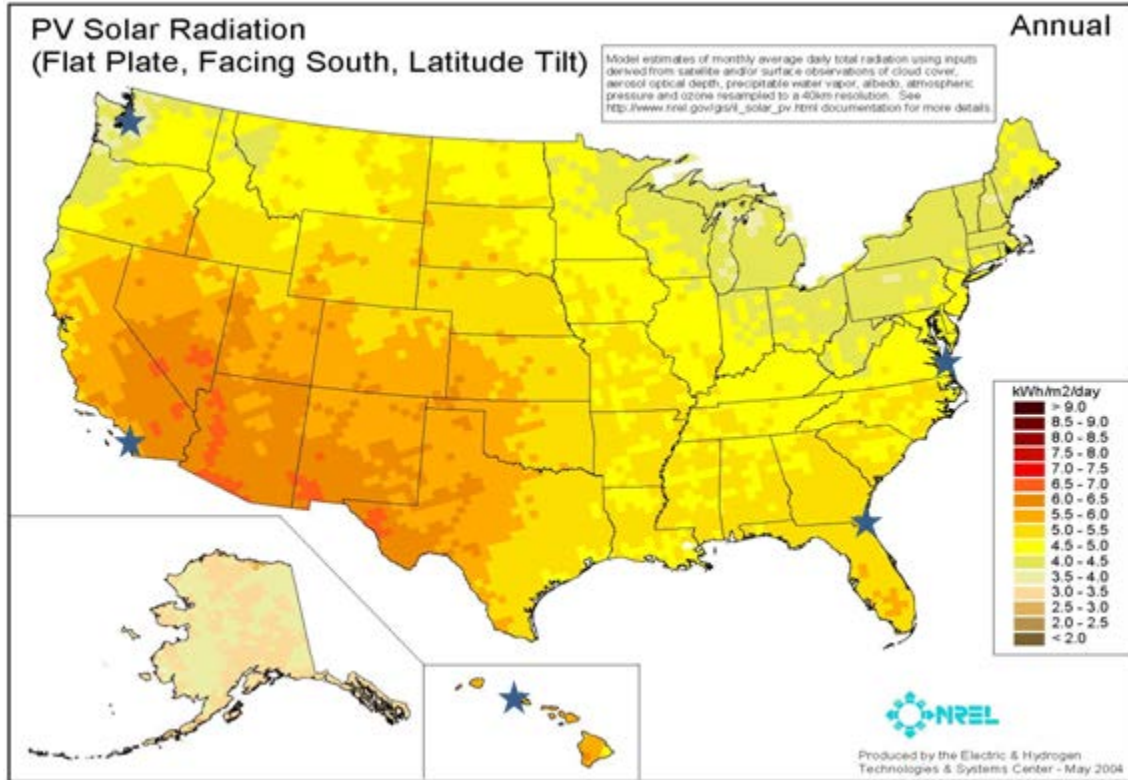

Figure 19. Annual sunlight coverage for the U.S. in kWh/m<sup>2</sup>/day of input power. From [9]

Major U.S. Navy homeports are indicated in Figure 19 by gray stars. It is clear that with the exception of Bremerton, Washinton, all the homeports receive five or more kWh/m<sup>2</sup> of sunlight per day on average.

## 2. Solar Power Capacity of Surface Combatants

Using the thin film solar cells discussed in Chapter II, we can calculate estimated solar power generation figures for the four ship classes investigated in this thesis. By assuming a 50 percent solar panel coverage on average, the available surface area figures displayed in Table 3 can be reduced to the solar illumination figures displayed in Table 7.

Table 7. Average solar illumination figures for surface combatants

Class	Available Surface Area	Illuminated Area
LCS-1 <i>Freedom</i>	2,536.4 m <sup>2</sup>	1,268 m <sup>2</sup>
LCS-2 <i>Independence</i>	3,310.3 m <sup>2</sup>	1,655 m <sup>2</sup>
LPD-17 <i>San Antonio</i>	7,561.4 m <sup>2</sup>	3,780 m <sup>2</sup>
LHD-1 <i>Wasp</i>	4,532.4 m <sup>2</sup>	2,266 m <sup>2</sup>

By using the values listed in Table 7, as well as the data in Figures 18 and 19, the annual estimated solar power generated can be calculated. For the sake of these calculations, assume LCS-1 *Freedom* spends four months in port in Singapore. She then spends the next eight months at sea and conducting port-visits throughout South East Asia. Based on the map illustrated in Figure 18, this would mean that the *Freedom* spent the entire year in a region that receive between 1,000 and 3,000 hours of bright sunlight per year. To arrive at a conservative estimate, the average of 2,000 hours is used for calculations. We also assume a solar irradiance of 1 kWh/m<sup>2</sup>. Multiplying the solar irradiance by the number of hours of sunlight per year yields a value of 2,000 kW/m<sup>2</sup> of input solar power per year. Multiplying this result by the amount of illuminated surface area yields a total value of 2,536,000 kW of solar input power. Once this value is multiplied by the 13 percent solar cell efficiency, a final value of 329,680 kW of power produced via solar power per year. This translates into a yearly production of 329 MW and a daily production of 903 kW.

The same set of calculations for a *San Antonio* class ship stationed in Norfolk and conducting a deployment to the Middle East was performed. It was assumed that the ship spent four month in port and then eight months at sea in the Atlantic Ocean and the Mediterranean Sea. For this schedule, the ship’s solar panels would have generated an estimated 1,081 MWh of energy for the year; or 2.96 MWh per day.

To provide an equal comparison for all four ship types, assume that in one year, each ship spends 180 days in port in San Diego or operating in the local area. It then

spends 185 days conducting a Western Pacific deployment. By using the calculation method above, the yearly power generation figures displayed in Table 8 were determined.

Table 8. Yearly power generation figures for a Pacific Fleet ship.

<b>Class</b>	<b>Power Generated in a Year (MW-h)</b>
LCS-1 <i>Freedom</i>	334
LCS-2 <i>Independence</i>	450
LPD-17 <i>San Antonio</i>	1029
LHD-1 <i>Wasp</i>	617

The values calculated above represent a significant amount of energy production. These values are obviously only a conservative estimate and are for one ship only. These figures would increase by a factor of 10 or 100 depending on how many ships in the fleet were equipped with solar panels. Real-world schedules and operational tempos will play a large factor in the type of solar environment where a ship spends its time. Nonetheless, these results demonstrate that the idea of using solar panels on surface combatants can have a noticeable impact on the way in which the Navy produces energy aboard its ships.

### **3. Real World Savings and Cost**

With many “renewable” energy sources, much of the cost is incurred up-front with fabrication and construction, while the savings is realized over the long term. Solar power is no different. The current industry standard is roughly a dollar per Watt of energy produced. This estimation translates into approximately \$300 for the cost of one of the 2.5 m<sup>2</sup> panels discussed in Chapter II. With this price-point in mind, the cost to outfit the four classes of ships investigated with solar panels is listed in Table 9.

Table 9. Cost to outfit solar panels to various ship types.

<b>Ship Type</b>	<b>Surface Area</b>	<b>Solar Panel Cost (approx.)</b>
LCS-1 <i>Freedom</i>	2,536.4 m <sup>2</sup>	\$304,000
LCS-2 <i>Independence</i>	3,310.3 m <sup>2</sup>	\$397,000
LPD-17 <i>San Antonio</i>	7,561.4m <sup>2</sup>	\$907,000
LHD-1 <i>Wasp</i>	4,532.4 m <sup>2</sup>	\$544,000

As is clearly illustrated in Table 9, the cost to equip the Navy’s surface combatants is expensive. Once the cost of design, installation, and energy storage is considered, the cost increases to over a million dollars per ship. However, this cost is only incurred at the onset, whereas the savings realized in both fuel and money will be felt over the life of the system.

An additional “cost” that must be considered is the weight of the solar cells themselves. For calculation purposes, the weight specification from the thin film cell discussed in Chapter II are used: 13.2 lbs for a 2.5 m<sup>2</sup> panel. When this figure is factored into the total surface area and displacement of the ship types being investigated, the final weight added due to solar panels is relatively small. These results are displayed in Table 10.

Table 10. Weight added and percent change in displacement due to adding solar panels on various warship types.

Ship Type	Displacement (tons)	Surface Area	Weight Added (tons)	Percent Change in Displacement
LCS-1 <i>Freedom</i>	3,089	2536.4 m <sup>2</sup>	6.7	0.21%
LCS-2 <i>Independence</i>	2,790	3,310.3 m <sup>2</sup>	8.7	0.31%
LPD-17 <i>San Antonio</i>	25,885	7,561.4 m <sup>2</sup>	20	0.08%
LHD-1 <i>Wasp</i>	40,650	4,532.4 m <sup>2</sup>	12	0.03%

Based on the data contained in Table 5, a rough estimate can be calculated to illustrate the amount of money that can be saved per day each ship spends in homeport. For this calculation, the ships in question will be home-ported in San Diego, California (the location from which the data in Table 5 was calculated). A value of six kWh/m<sup>2</sup> per day of solar irradiance will be assumed based on the solar coverage chart displayed in Figure 14, as well as a cell efficiency of 13 percent. These estimates are displayed in Table 11.

Table 11. Estimated in-port savings due to solar panels.

Ship Type	Daily Electrical Usage (MWh)	Daily Electrical Cost (avg)	Daily Solar Power Production (MWh)	Daily Savings from Solar Power	Yearly Savings from Solar Power (180 days)
LCS-1 <i>Freedom</i>	18.5	\$1,776.00	0.988	\$94.85	\$17,072.64
LCS-2 <i>Independence</i>	17	\$1,698.00	1.29	\$128.94	\$23,208.86
LPD-17 <i>San Antonio</i>	81.3	\$8,310.00	2.95	\$301.37	\$54,246.21
LHD-1 <i>Wasp</i>	71.4	\$7,759.00	1.77	\$192.13	\$34,582.97

From Table 11, it is clear that the use of solar power can have a noticeable impact on the electric bills of the Navy’s surface combatants when in port. While the amount saved per ship is relatively small when compared to the Navy’s operating budget as a whole, it is clear that this number will be significant when the savings are multiplied by multiple ships over multiple years. These figures also only take into account the in-port savings. Additional savings can be realized at sea due to fuel savings as well.

By continuing with the assumption that each ship conducts a 185 day deployment to the Western Pacific, an estimate of the amount of fuel and money saved can be calculated. The data displayed in Table 6 illustrate the hourly fuel consumption required to produce electricity. Additionally, average electrical loading figures for select ships were provided by personnel from Expeditionary Strike Group Three [21]. Since the daily solar power generated can be calculated using the same method employed above, a simple comparison can be made to illustrate how much fuel it would take to generate a like amount of electricity. These figures are displayed in Table 12.

Table 12. Daily and yearly fuel savings (approx.).

Class	GPH Towards Electrical Use (approx.)	Average Electric Loading (MW)	Daily Solar Power Generated (MW)	Daily Fuel Saved (Gal)	Daily Savings	Yearly Savings
LPD-17 <i>San Antonio</i>	259	2.5	2.7	280	\$840.00	\$155,400.00
LHD-1 <i>Wasp</i>	876	2.8	1.62	507	\$1,521.00	\$281,385.00

It is clear from the results displayed in Table 12 that significant savings in both fuel and money can be realized by employing a solar power system. When the at-sea and in-port savings are combined into one yearly figure, it becomes apparent that the initial cost of the system can be paid back in only a few years. Any savings realized after that payback is pure “profit”. Additionally, the amount of fuel savings begins to accumulate immediately. In fact, the amount of fuel saved on board a *San Antonio* class ship after 185 days at sea would be enough to generate over a week’s worth of electricity. Similarly, the amount of in-port savings realized by an *Independence* class ship would be enough to purchase almost two weeks’ worth of in-port electricity.

#### **D. SOLAR PANEL DURABILITY**

It is not enough to prove that there is sufficient space and need for solar panels aboard ship. Once there, they must remain in working condition in order to ensure the maximum amount of energy production. To accomplish this, the panels must be protected against both naturally occurring and man-made hazards. These include salt spray, rain, wind, hail, snow, falling objects, aircraft and aircraft exhaust, as well as any number of unforeseen dangers that could arise from being employed on a warship at sea.

In private industry, thin film solar cells are produced to withstand similar sets of conditions. They are often placed on the roofs of buildings and homes. They must, therefore, also be capable of withstanding the elements while still producing power for long periods of time. Typically, thin film cells are warranted for multiple decades. For example, one leading producer of thin film solar cells provides a five, 10 or 25 year warranty against power loss for their product [22]. This warranty is broken down by percent of maximum power yield over the set periods of time. This means that over time, the output power will naturally decrease, but the consumer is protected against too large of a decrease.

The same cell is protected against the elements by utilizing a thin glass coating with a moisture sealant to protect against water damage. While this renders the module rigid, it does provide a high degree of strength. It is rated to withstand loads of up to  $5400 \text{ N/m}^2$  [22]. This translates into a weight of over 1200 lbs. However, using glass adds weight. Therefore, lighter materials must be utilized that still provide a degree of strength and protection from the elements. One method involves a coating that uses multiple layers of flexible materials interspersed with layers of glass and other weather-resistant materials. The result is a coating that is flexible, strong, and proof against the elements [23]. Such a method would be ideal for shipboard application as it would also be lightweight.

#### **E. OPERATIONAL CONCLUSIONS**

Based on the current fuel and electrical usage by Navy surface combatants and the resultant savings that can be realized from utilizing solar power both at sea and in port, a

solar power system is both operationally practical and feasible. Another factor affecting this conclusion is the fact that a relatively small addition in overall ship's displacement would be required to implement a solar power system. Additionally, the solar cells themselves are durable and could have a coating applied that would increase their capacity to withstand both the elements and any man-made hazards. Finally, the savings in both fuel and money that can be realized (as well as decreasing the Navy's overall impact on the environment) make this a proposition that cannot be ignored.

## **IV. ENERGY STORAGE**

While it is one thing to be able to generate a usable amount of power, it is something else entirely to store that power for future use. Currently, the Navy uses various forms of generators to provide electrical power for auxiliary loads aboard surface combatants. These generators are fueled by either diesel or gasoline which must safely be stored in large tanks aboard ship.

The generation of electricity via solar panels would require additional energy storage capacity beyond the current capabilities aboard surface combatants. This function is currently accomplished via a lead-acid battery aboard U.S. Navy submarines, but no such requirement currently exists for surface combatants. However, some form of additional storage capacity is required. There are multiple forms of energy storage devices currently available to accomplish this. However, whatever method is chosen will have to meet Navy safety standards as well as being of a suitable size and weight to not detract from the overall gain in capability provided by the solar panels. Three different energy storage technologies researched were batteries, flywheels, and fuel cells.

### **A. BATTERIES**

#### **1. History and Operation**

The first battery was invented in 1800 by Alessandro Volta of Italy [12]. It was constructed of alternating discs of zinc and copper separated by cardboard and utilized a brine solution as its electrolyte. Battery technology has come a long way in the last 213 years, including the first dry cell battery invented in 1949 [12]. The first rechargeable battery was a rudimentary lead-acid battery and was invented by Gaston Plante in 1859 [12]. This field also experienced large growth and technological advance with rechargeable batteries evolving through nickel-cadmium, nickel-lead, nickel-metal-hydride, and, finally, arriving at lithium-ion batteries in the 1970s [12]. It is the field of rechargeable batteries that is of interest. Since the solar cells will be the power source, a rechargeable battery can be used to store the power generated throughout the day and then discharge it during periods of night or low sunlight.

Battery construction and operation is relatively universal, regardless of type. Energy is stored as chemical energy and converted into electrical energy through reduction-oxidation (redox) reactions [12]. These reactions occur at the two electrodes of an electrochemical cell: the anode and the cathode. The anode is the electropositive electrode from which electrons are generated. Separating the two electrodes is the electrolyte, which allows for the flow of ions in the battery. The electrolyte is commonly a liquid solution containing a salt dissolved in a solvent. The cathode is the electronegative electrode. During battery discharge, positive ions migrate to the cathode while electrons migrate through the external electric circuit. During battery charging, the positive ions and electrons merely flow in opposite direction [12]. An illustration showing this layout along with major components is illustrated in Figure 20.

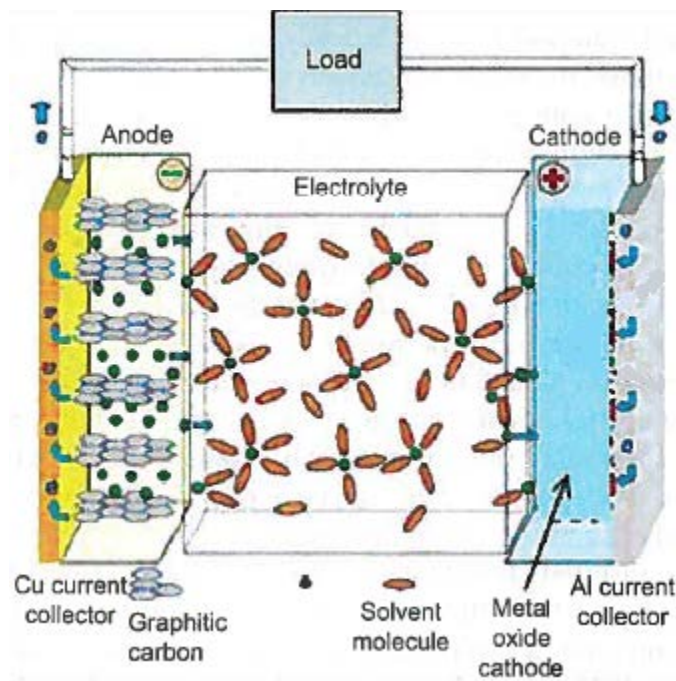

Figure 20. Illustration of a generic Lithium-Ion battery showing major components. From [12]

The various components of a typical battery are clearly illustrated in Figure 20: the anode, cathode, electrolyte, and the collector. The collector allows the transport of

electrons to and from the electrodes. It is typically made of a metal such as copper or aluminum and cannot react with either the cathode or the anode [12].

While the Lithium-ion battery illustrated in Figure 20 is one of the more common forms of rechargeable battery today, there is another type of rechargeable battery that has seen use in naval applications for decades. That battery would be the lead-acid battery. Lead-acid batteries have been utilized aboard U.S. nuclear submarines as a back-up source of power for decades. Lead-acid batteries are characterized by having both the anode and cathode use the same active material, lead [24]. The electrolyte is typically sulfuric acid. The physical design and chemical reactions inherent in a lead-acid battery lead to a relatively high cell voltage of 2 V. However, there are a number of unwanted reactions that are always present in lead-acid batteries: [24]

- Oxygen production at the positive electrode
- Oxygen reduction at the negative electrode
- Hydrogen production at the negative electrode
- Grid corrosion

While only Lithium-ion and lead-acid batteries were discussed in this section, there are many other types of rechargeable batteries.

## **2. Applicability**

Batteries have been used aboard naval vessels for many years. However, their large scale use aboard surface combatants would be a new departure. It would thus be important to determine which type of battery would be the best match. A listing of various types of rechargeable batteries and their pertinent electrical characteristics is displayed in Table 13.

Table 13. Comparison of common rechargeable batteries with pertinent electrical characteristics. From [24]

Type	Nominal Voltage (V)	Theoretical Specific Energy (Wh/kg)	Actual Specific Energy (Wh/kg)
Lead-Acid	2	161	20 - 50
Nickel/cadmium	1.3	240	20 - 55
Nickel/metal hydride	1.3	≈300	50 - 80
Lithium-ion	3.6	>450	≈100

Even though the data listed in Table 13 is from 2003, it would appear that the best choice in terms of energy capacity per unit weight is a Lithium-ion battery. While their potential is great, they can be very dangerous as evidenced by recent incidents involving the Navy’s Advanced Seal Delivery Vehicle and Boeing’s *Dreamliner* aircraft. As with any relatively new technology, the advantages must be weighed against the disadvantages. With a relatively high specific energy, and the ability to be scaled up to meet the demands of a large surface combatant, Lithium-ion rechargeable batteries would be the battery of choice to be paired with a solar power system.

## B. FLYWHEELS

### 1. History and Operation

As the oldest form of energy storage/conversion researched, the concept of the flywheel has existed for hundreds of years. In fact, records exist which suggest that flywheels were used as early as the twelfth century. They were also used during the Industrial Revolution by such inventors as James Watt and James Pickard. In practice, a flywheel is nothing more than a rotating mechanical device that is used to store rotational energy. Current common uses of flywheels include: [12, 25]

- Providing continuous energy when the energy source does not itself provide continuous energy.
- Delivering energy at rates beyond the ability of a continuous energy source.

- Delivering boost acceleration to automobiles in a process known as regenerative braking.
- Serving as an uninterruptible power supply (UPS) to data centers.

Flywheels have traditionally been made of metals such as steel. However, steel suffers from a low specific strength and stiffness-to-weight ratio [12]. These attributes can lead to structural failure, which produces dangerous shrapnel. Currently, flywheels are being constructed of such materials as Kevlar and carbon-composites which have much better strength properties [12]. This allows them to spin faster, which translates into more energy storage capacity.

Flywheel operation is incredibly simple. Energy is stored in the spinning wheel as rotational energy. Energy is transferred to the flywheel either mechanically via a torque or electrically via an electric torque. As the torque is increased, the wheel spins faster, increasing its amount of stored rotational energy. Conversely, energy is dissipated from the wheel by applying a torque on a load, either mechanically or electrically [25]. Energy capacity is proportional to the square of the angular speed of the wheel, and is defined as

$$E = \frac{1}{2}mr^2\omega^2 \quad (4.1)$$

where  $m$  is the wheel mass,  $r$  is the radius of the wheel, and  $\omega$  is the rotational velocity. Therefore, according to Equation 4.1, as the flywheel speed increases, its capacity to store energy increases.

## 2. The Modern Flywheel

As was previously stated, in order to achieve higher speeds and store more energy, many modern flywheels are being constructed of carbon-composite materials. Not only does this material allow for higher speeds when compared to steel, but they also weigh less than a steel flywheel of comparable size [12]. In traditional mechanical flywheels, the wheel itself would rotate freely utilizing metal ball-bearings. This method however, can introduce friction losses into the system which can reduce the amount of energy stored by up to 50 percent over two hours [26]. One method to lessen these losses involves the use of magnetic bearings with the wheel itself encased in a container that is

maintained at a near-vacuum state. This type of flywheel has reduced energy storage losses on the order of three to five percent per hour, significantly less than with mechanical bearings. Additionally, this set-up can achieve a round-trip storage efficiency of 85 percent [12]. Current research into superconducting magnetic suspension promises to reduce the energy storage losses even further, to as low as 0.1 percent per hour [12].

Such use of modern materials and techniques allows for impressive operational statistics. Many modern flywheels are able to achieve speeds up to 50,000 RPM and faster [12]. One such modern flywheel is an experimental unit manufactured by NASA that is capable of speeds up to 60,000 RPM. This unit is shown in Figure 21.



Figure 21. The NASA G2 experimental flywheel: capable of speeds up to 60,000 RPM.  
From [12]

This high rate of angular velocity can yield high energy storage capability depending on the size of the flywheel. There are currently a number of installations utilizing multiple flywheels that have an energy storage capacity of up to five MWh [12].

### **3. Applicability**

Even during the sunniest, cloud-less day, solar cells will be a discontinuous energy source due to fluctuations in sunlight, changes in cloud-cover, and changes in

other atmospheric conditions. Because of this, it would seem that Flywheel technology would be a very fitting form of energy storage to pair with solar power; especially since one of the current uses of flywheel energy storage is in providing continuous power from a discontinuous energy source. Additionally, there are no hazardous gases or byproducts created from the use of a flywheel, as with some other forms of energy storage.

However, there are a number of limitations to this technology that prevent its use as a large scale energy storage system aboard surface combatants. First, a single flywheel can only discharge its energy for a number of minutes at most. By putting multiple flywheels in parallel and staggering their discharge, a longer duration can be achieved. However, this limits the energy discharged to a single flywheel’s rated energy storage level. This would be less than the total energy provided by the solar panels. An illustration of this is depicted in Table 14.

Table 14. List of run times for various flywheel / output power rating combinations. From [27]

UPS Output Power Rating (kVA)													
Number of Flywheels	40	60	80	100	120	160	225	300	400	600	750	1100	
1	105	71	53	42	34	24	13	7					
2			102	82	68	51	36	26	16	7			
3						77	55	41	30	16	10		
4	Run time in seconds								54	41	25	18	8
5										51	34	25	13
6											41	32	19

As is clearly illustrated in Table 14, longer run times can be achieved for a given load by employing multiple flywheels, but the run-times themselves are only on the order of minutes. This will not be sufficient aboard surface combatants fitted with solar panels when the length of time without sunlight will be measured in hours or possibly days.

An additional possible limitation is in the size and weight of the flywheel systems themselves. Aboard naval vessels, both of these characteristics are at a premium and

must be optimized in order to get the most out of the ship. The specifications illustrated in Table 14 are representative of a commercially available flywheel utilized as an UPS. A single flywheel system with a maximum power of 300 kW weighs over 1500 lbs., has a 900 in<sup>2</sup> footprint, and is over six feet tall [27]. Multiplying these dimensions by the numbers necessary to achieve a reasonable power output over a significant period of time would yield a system that weighs many tons and takes up sizeable space.

Another limitation has to do with the operation of a flywheel itself. As a single port device, a flywheel cannot be both charged and discharged simultaneously. Additionally, once a flywheel has achieved its maximum power / speed, power must be applied in order to maintain its maximum potential. Otherwise, the flywheel will gradually slow down and lose its stored energy. Multiple flywheels could be used to overcome the single port limitation, but as stated earlier, this could result in a very large and heavy system.

Under current levels of technological maturity and research, and with these facts in mind, long-term energy storage using flywheels does not pair well with solar power for use aboard surface combatants. Flywheels can have an impact aboard surface combatants as a UPS backup and as a source of pulse power for large electrical loads such as high-energy weapons or radars. Both these applications are well within the current technological readiness and usage of flywheel energy storage.

## **C. FUEL CELLS**

### **1. History and Operation**

As the third and final means of energy storage investigated, fuel cells are also the newest in terms of when they were invented and developed. Their invention came in 1839 when Sir William Grove proved experimentally that generating electricity from the reaction of gaseous oxygen with hydrogen was possible [28]. The term “fuel cell” itself was not coined until 1889, and it would be 1959 before the first truly workable fuel-stack was built: it produced 5 kW of power [28]. From that point, fuel cell research intensified; with applications in space craft, automobiles, and stationary power generation.

In construction and basic operation, a fuel cell is similar to a battery. In its simplest form, a fuel cell is a negatively charged anode and a positively charged cathode separated by an electrolyte (either a watery acidic solution or a plastic membrane that will allow the migration of electrically charged hydrogen atoms from the anode to the cathode) [28]. A simple representation of a fuel cell is illustrated in Figure 22.

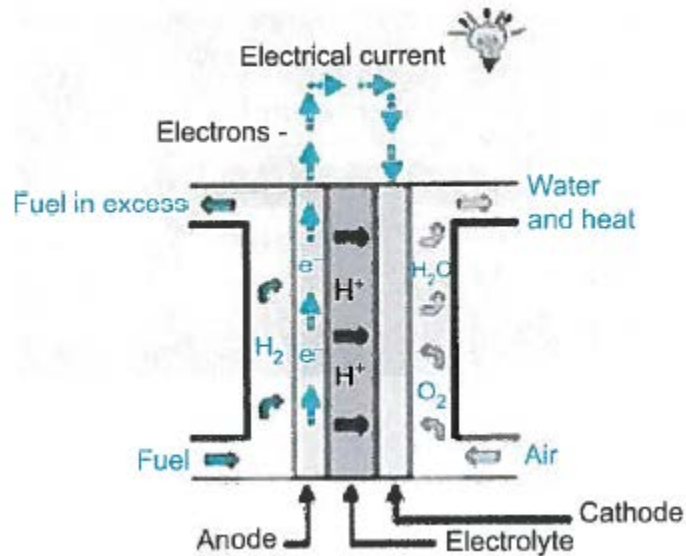

Figure 22. A schematic representation of a single cell in a proton-exchange membrane fuel cell, showing major components. From [12]

The operation of a fuel cell is also shown in Figure 22. Molecular gaseous hydrogen (fuel) is fed into the cell on the anode side. Electrons are stripped from the hydrogen molecules, leaving positively charged hydrogen ions. These migrate through the electrolyte to the positively charged cathode, where they combine with oxygen (either from air or carried in tanks) to form water. Back at the anode, the electrons flow out of the cell to the load and then back to the cathode, completing the circuit [28].

There are many different types of fuel cells available currently. Their design, materials, and applications are all very different. Some various fuel cell types along with pertinent operating data are listed in Table 15.

Table 15. Different types of fuel cells with pertinent operating data and typical application. From [12]

Type	Electrolyte	Fuel	Operating Temp (C)	Power Level (kW)	Typical Applications
Solid-oxide Fuel Cell	Ceramic, solid oxide, zirconia	Hydrogen or Methane	500 - 1000	100 - 100,000	Combined heat and power (CHP), power generation, transportation
Molten-carbonate Fuel Cell	Molten Lithium carbonate	Hydrogen	630 - 650	1,000 - 100,000	Large stationary power
Phosphonic acid Fuel Cell	Phosphonic acid	Hydrogen	150 - 210	100 - 5,000	CHP, power generation
Proton-exchange Membrane Fuel Cell	Sulfonic acid membranes	Hydrogen	50 - 90	0.01 - 1,000	Transportation, power supplies, CHP, distributed power
Alkaline Fuel Cell	Potassium hydroxide	Hydrogen	50 - 200	10 - 100	Space, power generation
Direct Method Fuel Cell	Sulfuric acid, sulfonic acid membrane	Methanol	50 - 110	0.001 - 100	Portable power, consumer electronics

It may be helpful to think of a fuel cell as an engine. Fuel is introduced, and electricity is produced. However, there are no moving parts and the byproducts are water, heat, and hydrogen. In this sense, there is no real ability to “store” energy like a battery that has a finite amount of energy it can discharge per cycle. The real ability of a fuel cell to produce power lies in the amount of fuel (hydrogen) and oxygen (air) available to it.

## 2. Applicability

If a fuel cell has no real ability to store power, than how can it possibly be paired with solar power to produce energy during periods of no sunlight? As noted, a fuel cell’s ability to produce power is directly tied to the amount of fuel and air that it can be provided. On a surface combatant, there is no shortage of air since the ship is open to the atmosphere. But where will the hydrogen come from? Traditionally, a finite amount would be supplied via tanks. Once this supply was depleted, the fuel cell would stop producing energy. However, if there was a near-continuous source of hydrogen, then the fuel cell could be operated near-continuously. During sunlight hours, a portion of the power produced from the solar panels could be diverted for electrolysis. Through

electrolysis (the splitting of water into oxygen and hydrogen via electricity), a large supply of hydrogen could be generated and stored for use by the fuel cell when the solar panels cannot produce power. The water needed for this process could either be pulled from the ship's normal fresh water supply or could be drawn from the water produced by the fuel cell during operation. This water could be stored in a holding tank and used for either daily ship's needs or reused in the electrolysis process, depending on how much is needed. This type of system is called a regenerative fuel cell, and a generic design is illustrated in Figure 23.

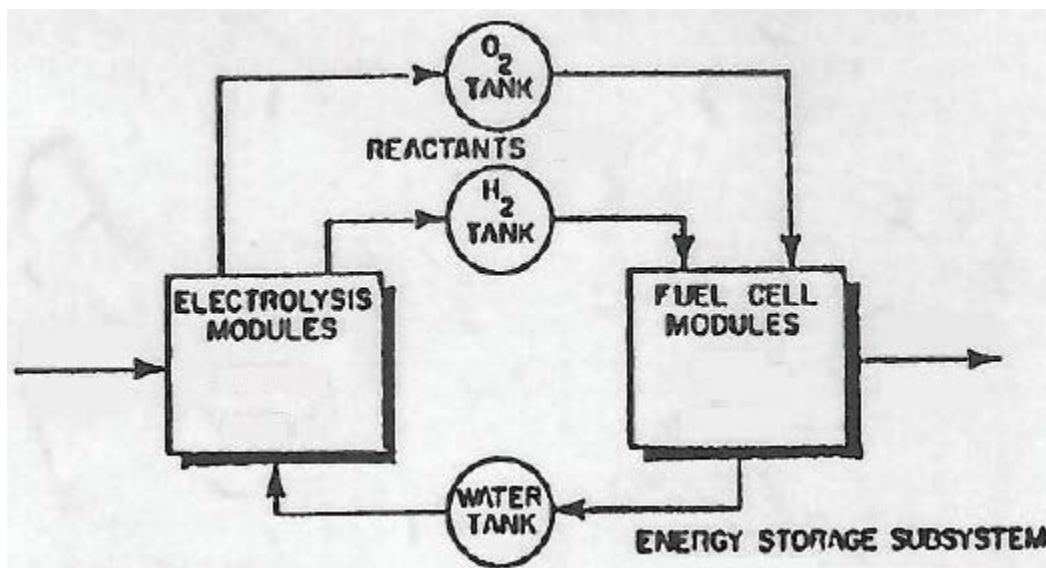

Figure 23. Depiction of a generic regenerative fuel cell system.

From Figure 23, it is clear how the system functions. Power would be fed into the electrolysis module which would create the fuel needed to power the fuel cell. The byproducts of the fuel cell could then be fed back into the electrolysis module, and the cycle would repeat. For a shipboard case, however, the oxygen tanks would be superfluous, since the fuel cell could be supplied oxygen via the air in the atmosphere. Similarly, water could be supplied from the ship's water supply. The elimination of these two dedicated tanks could possibly save weight and space.

#### D. COMPARISONS AND CONCLUSIONS

With a limited number of peak sunlight hours in many locations on the globe, the ability to store a portion of the power generated via solar power for later usage is critical. With many different methods of energy storage, identifying the most appropriate one for this unique application is important.

Owing to the limitations inherent with flywheel energy storage in terms of available energy discharge time, this technology in its current form must be eliminated from consideration. However, this technology offers some unique advantages: notably the generation of no byproducts and the need for no external fuel. At their current level of technological maturity, these types of systems can have a role in pulse power generation, which will be increasingly important in the future as the Navy progresses towards higher-energy weapons and sensors.

With the elimination of the flywheel, the two remaining energy storage options are the battery and the fuel cell. Each of these technologies has advantages and disadvantages when compared to the other. One of the most important factors in this decision, however, must be the energy density of the respective technologies. Current values for this characteristic are shown in Table 16.

Table 16. Energy output comparison of energy storage devices. From [12]

Storage Device	Energy Output (kWh/kg)
Lithium Battery	0.8
Hydrogen Fuel Cell	1.1

It is clear from the data in Table 16 that at their current levels of technological maturity the fuel cell has an advantage over the battery. In the area of byproducts and materials needed for operation, the battery would appear to have an advantage since it requires no “fuel” to operate. However, the fuel needed by the fuel cell can be safely stored aboard naval vessels, and the byproducts of the cell can either be recycled and used aboard ship or discharged overboard with minimal effect on the environment. Both

systems can be potentially dangerous to the ship and the crew if not operated correctly. However, both technologies are currently successfully employed aboard countless naval vessels around the world.

With these facts in mind, it becomes apparent that the fuel cell is the preferred energy storage method for a number of reasons. The first reason is its greater power capacity per unit weight. With size and weight restrictions being so important aboard a naval vessel, this is a large advantage for this technology. Also, fuel cells typically scale very well. The size of the ship and its energy needs could determine how many “modules” of a specific size are needed. This arrangement should reduce both the logistics and maintenance needs of the system. Additionally, the fact that a regenerative system could be implemented with little difficulty is another great advantage. In this configuration, any byproduct that is not reused can be merely exhausted overboard with little effect on the environment or ship.

THIS PAGE INTENTIONALLY LEFT BLANK

## **V. TACTICAL FEASIBILITY**

### **A. IMPORTANCE**

With the U.S. Navy being a predominantly forward-operating, war-fighting organization, tactical security factors must be taken into account when determining the feasibility of utilizing Solar Cells on surface ships. By reducing their IR signature and RCS, warships can reduce their detectability and increase their survivability. This enables them to operate more freely and conduct their missions with confidence and operational flexibility. With this fact in mind, it was vitally important to research the affects that Solar Cells would have on these two factors.

### **B. RCS AND REFLECTIVITY**

The first of the two tactical security factors that is examined is RCS or radar reflectivity.

#### **1. RCS Testing Methodology**

In order to determine the effect that placing solar cells on the skin of a ship would have on its radar reflectivity, a series of tests was conducted inside an RF anechoic chamber using two square Aluminum plates. One plate was left bare while the other had a small solar array affixed to it. These were then run through a series of radar reflectivity tests in the chamber to determine the effect that the array would have. All tests were performed in both the C-band and X-band due to their prevalence in military applications.

The methodology for this series of tests was simple. To begin, the bare metal plate was run through the test at a number of angles to determine its baseline radar reflectivity. This was followed by performing the same test using the plate with the array affixed to it. Deviations from the baseline could then be examined. Additionally, some tests were performed using two separate array configurations. In the first configuration, the array was raised up from the surface of the plate. In the second configuration, the array was flush with the surface of the plate. This was performed to determine what effects the change in physical configuration would have on the radar reflectivity values.

## 2. C-Band Testing

The first series of tests was conducted in the C-band of the EM spectrum [4-6 GHz]. This spectrum was chosen because various naval surface search radars utilize this spectrum, including the U.S. Navy's AN/SPS-67 Surface Search Radar and the Chinese Type 354 Air and Surface Search Radar [29]. The first test conducted was with a raised solar cell array on the aluminum plate and is illustrated in Figure 24.

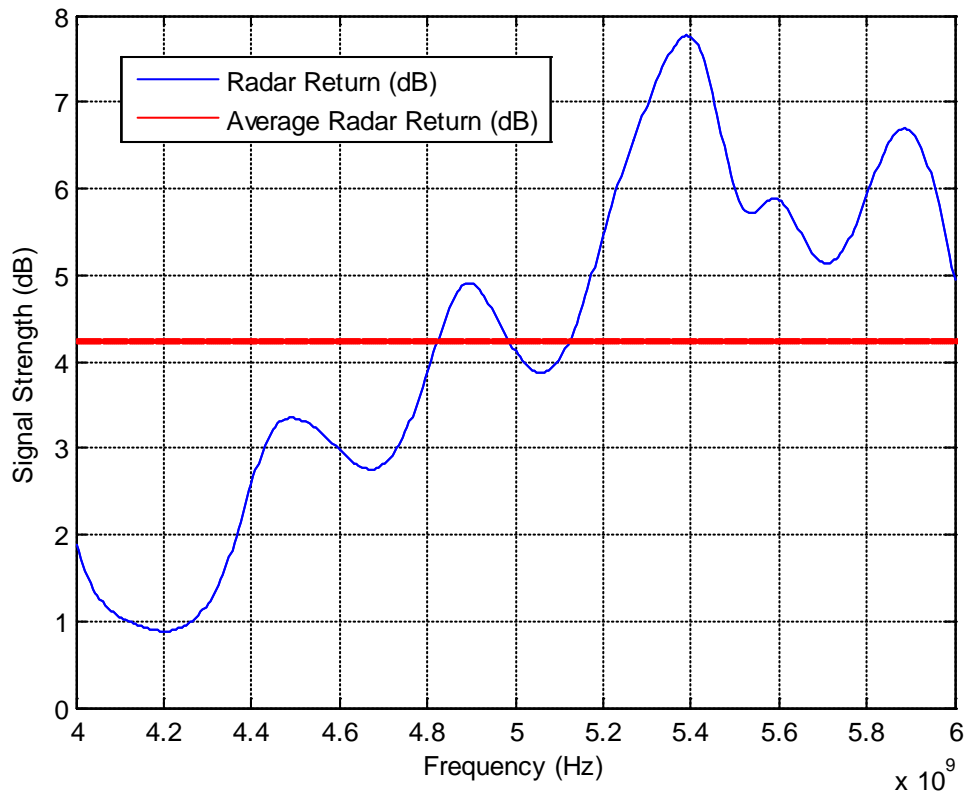

Figure 24. Raised solar array on an aluminum plate in the C-band.

From Figure 24, it can be clearly shown that the signal strength on the radar return increased with the addition of a raised solar array. This translates into an increased likelihood of detection as the return is now stronger than just the bare metal. This test was followed by altering the array so that it was in a flush position with respect to the metal plate. As can be seen in Figure 25, the strength of the return is less than that of the raised array illustrated in Figure 24 but still stronger than just the bare metal plate.

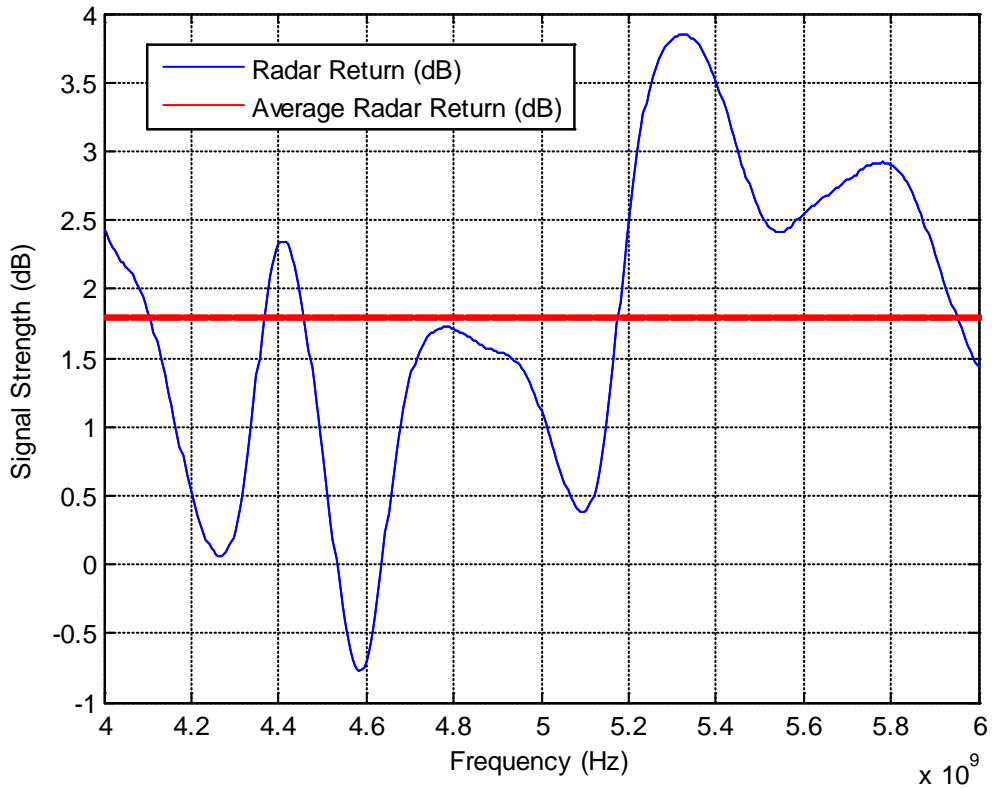

Figure 25. Solar array flush on an aluminum plate in the C-band.

The next step of the testing involved angling the plate. This was deemed necessary as it is reasonable to assume that solar arrays will not only be on large flat surfaces. This simulated a threat radar at a glancing angle vice a head-on approach. The first test at an angle was conducted utilizing a raised array on the metal plate. The results are illustrated in Figure 26.

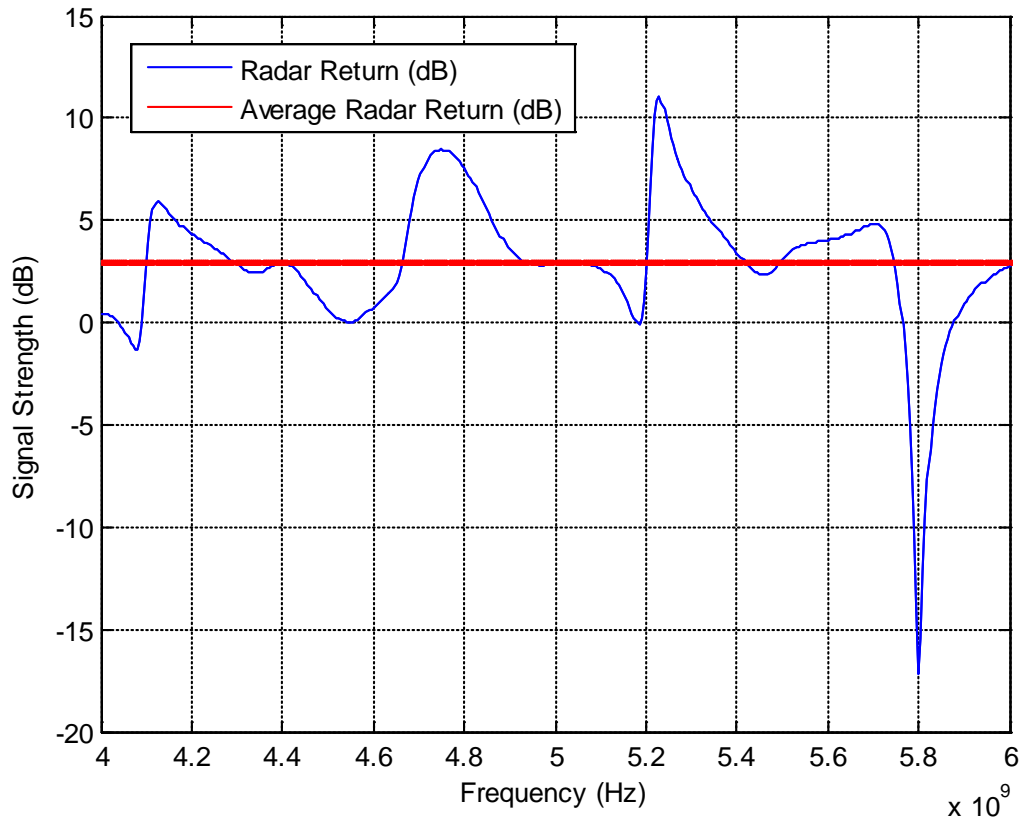

Figure 26. Raised solar array on an angled aluminum plate in the C-band.

From Figure 26, it can be seen that the addition of a raised solar array increases the signal strength of the return over most of the C-band when compared to the baseline bare metal plate. By altering the array to make it flush to the metal plate, a slightly better result is achieved, as illustrated in Figure 27.

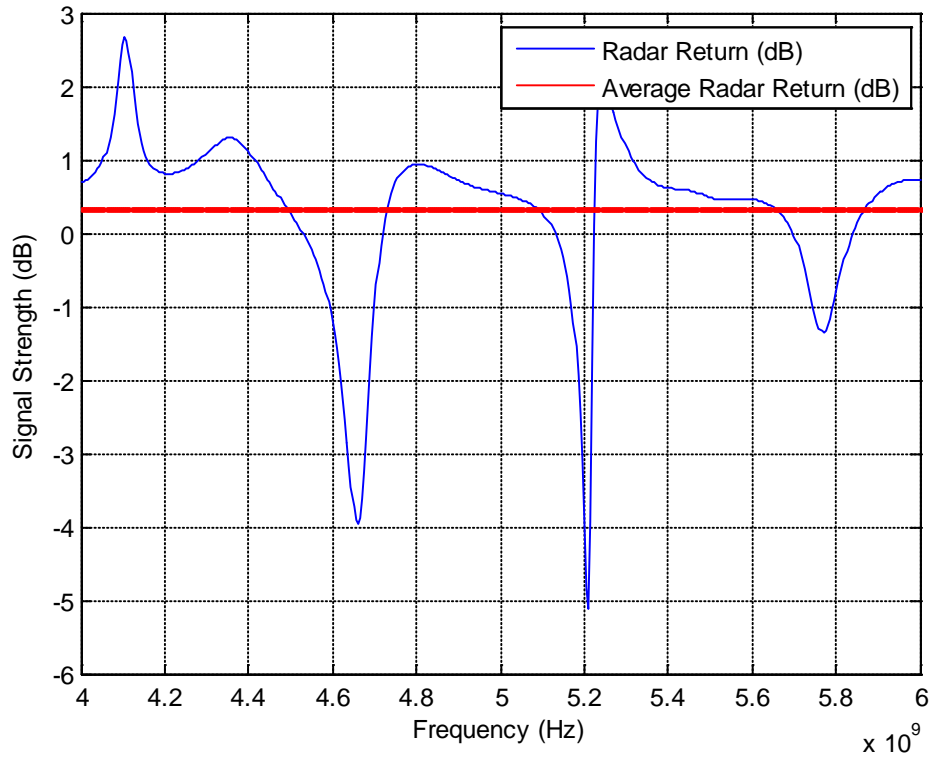

Figure 27. Solar array flush on an angled aluminum plate in the C-band.

It is clear from Figure 27 that while the flush array achieves a more desirable result than the raised array, it still yields a slightly stronger average return over the width of the C-band than the bare metal plate.

### 3. X-Band Testing

The second series of RCS tests was conducted in the X-band of the EM spectrum [8-12 GHz]. This band was also chosen due its usage in military radars. Two real world examples of radar systems that utilize frequencies in the X-band include the Chinese Type 352 Air and Surface Search Radar and the U.S. AN/SPS-73 Surface Search Radar [29]. The testing in the X-band followed a similar method as the testing in the C-band. The result from the initial test using a raised array on the aluminum plate is shown in Figure 28.

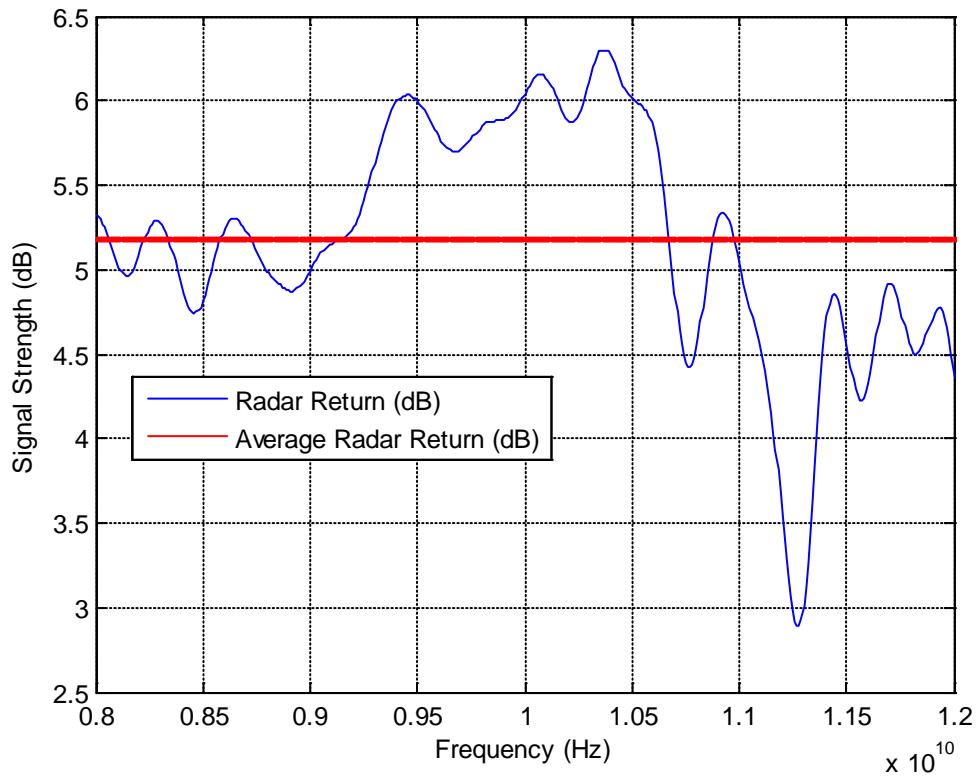

Figure 28. Raised solar array on an aluminum plate in the X-band.

It is clearly shown in Figure 28 that in this physical configuration, the presence of the solar array has a noticeable impact on the strength of the radar return. The return is much stronger than the baseline return for the bare metal. The test was run again using a different configuration: the solar array was placed flush with the aluminum plate. The results from this test are displayed in Figure 29.

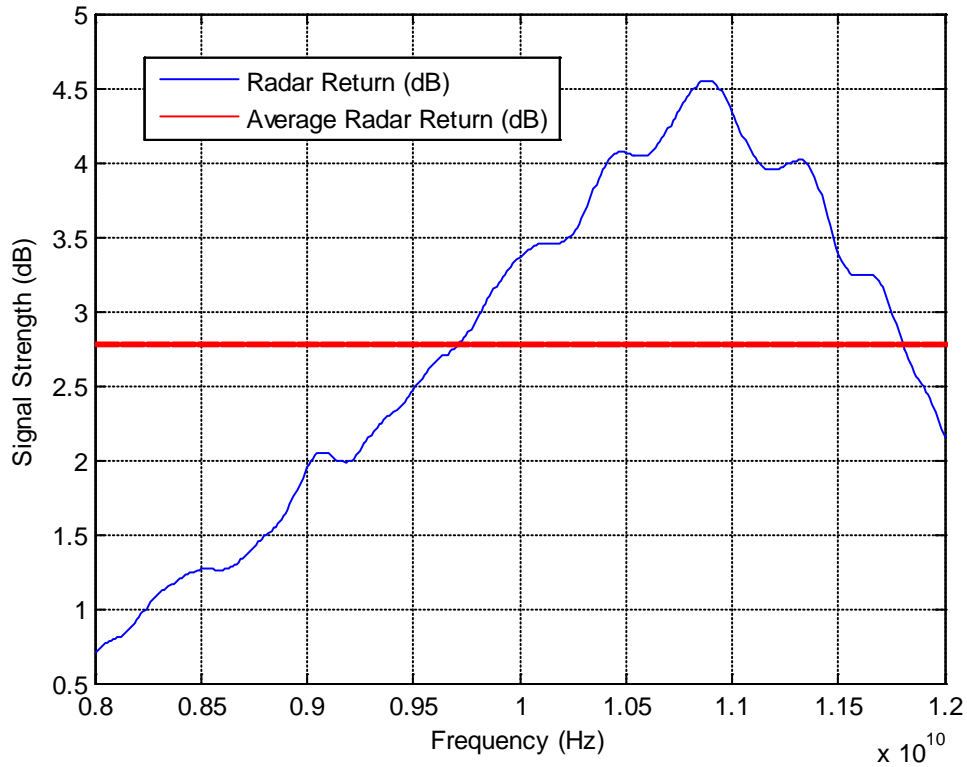

Figure 29. Solar array flush on an aluminum plate in the X-band.

It is clearly evident from Figure 29 that the average increase in return strength is less in the flush configuration than in the raised configuration. However, the return is still stronger than the return of just the bare metal plate. Similar tests were run with the plate in angled position with the array in both the raised and flush configuration. The results from those two tests are shown in Figure 30 and Figure 31.

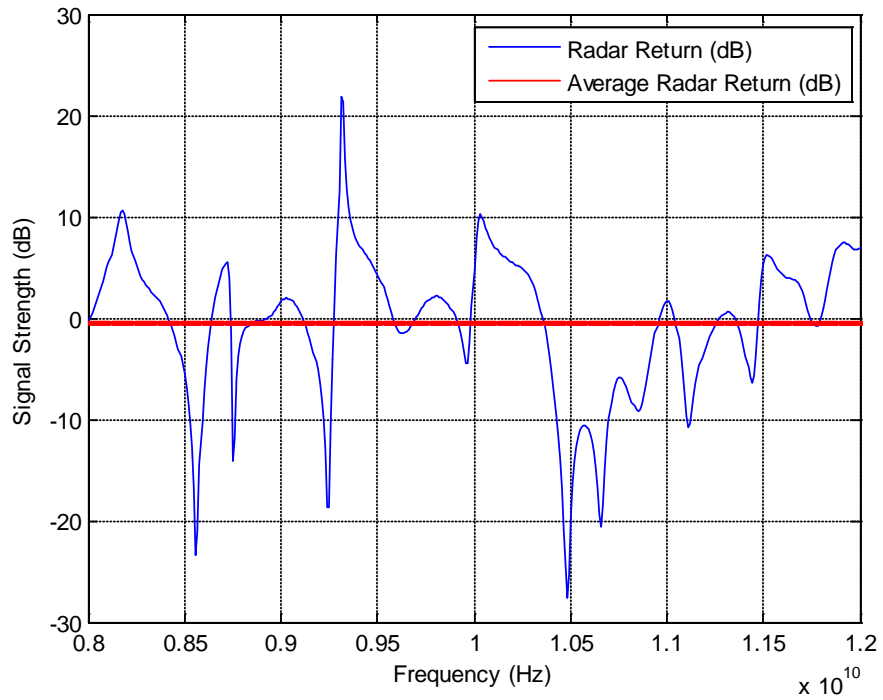

Figure 30. Raised solar array on an angled aluminum plate in the X-band.

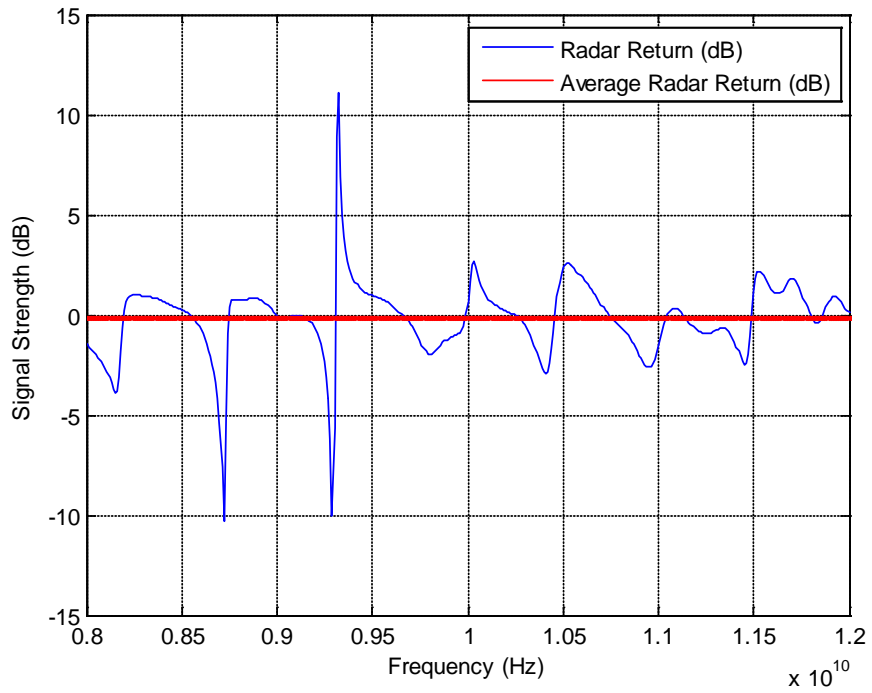

Figure 31. Solar array flush to an angled aluminum plate in the X-band.

It is clear from both Figures 30 and 31 that the average return strength in the angled position is actually lower than the return of the bare plate in the angled position. However, there are still multiple swaths of the band where the return is much stronger. According to these results, the detectability would either be increased or decreased depending on the specific operating frequency of the threat radar. Of interest in these last two tests is that the average return strength of the raised array was lower than that of the flush array, albeit with a much greater spread in return strengths. Of the four separate tests, this was the only instance in which the raised array out-performed the flush array configuration.

#### **4. RCS and Reflectivity Conclusions**

The results obtained in this series of tests regarding RCS and radar reflectivity are fairly conclusive. In all but two configurations in the X-band, the radar return strength ranged from slightly greater to significantly greater than the return strength of just the bare metal plate. This translates into an increase in radar detectability of a ship outfitted with solar arrays. However, it is also clear that in 75 percent of the cases, the flush configuration provided a smaller increase in the radar return strength, indicating that if solar arrays were to be utilized on board ships, that this configuration would provide the best option in terms of radar detectability.

### **C. IR SIGNATURE PERFORMANCE**

A ship's IR signature can be exploited by an adversary in both a search and targeting scenario. Warships, therefore, take steps to reduce this signature in order to decrease their detectability. It is therefore important to determine what effect, if any, the addition of solar arrays will have on a ship's IR detectability.

#### **1. Methodology and Testing**

In order to determine the effect that a solar array has on IR signature, a series of tests was performed using a solar array and various metal plates. Aluminum and steel plates were selected due to their frequent use in warship construction. Two plates of each type were utilized; one was left bare and the other had a solar array attached to it. IR

images were then taken using a “white hot” setting. The first test was run using the aluminum plates. The result is shown in Figure 32.



Figure 32. Comparison of aluminum plate with a solar array (left) to a bare aluminum plate (right) using a “white hot” setting.

As can be seen in Figure 32, the solar array is much whiter than the bare aluminum plate to its right. This indicates that the solar array has a very large IR signature as compared to the metal. This can be seen on the plate on the left where it transitions quickly from black to white. This is the edge of the solar array.

The next test was performed using steel plates in the exact same manner as the aluminum plate test. The results from this test are shown in Figure 33.

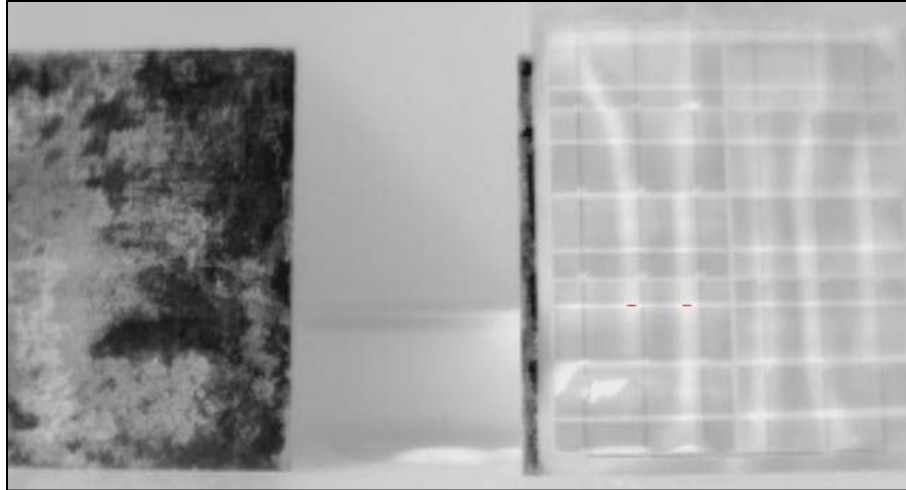

Figure 33. Comparison of a bare steel plate (left) with a steel plate with a solar array (right), using a “white hot” setting.

As can be seen in Figure 33, the solar array registers much “hotter” than either the metal it is affixed to or the bare metal plate to its left. Again, the transition from black to white on the right-hand side plate indicates the edge of the solar array.

## 2. IR Signature Conclusions

From the tests carried out with the Aluminum and steel plates, it is obvious that the addition of solar cells increases the IR signature of whatever they may be affixed to. This is not surprising as the cells themselves utilize the solar energy to create electricity. The interesting result is the stark contrast between the array itself and the metal behind/next to it. However, the added IR vulnerabilities from the solar arrays may pale in comparison to the other IR vulnerabilities already present in a ship from engine exhaust or radar arrays.

## D. TACTICAL FEASIBILITY CONCLUSIONS

The results obtained from the RCS and IR imagery tests are straightforward. The addition of the solar arrays that were used in these tests appears to increase the RCS and IR signature of a ship equipped with them. Further research into solar cell design and coatings may reveal new techniques to mitigate these risks. When examining a ship’s detectability, all factors must be taken into account, not just RCS and IR signature.

Acoustic detection, electronic detection, as well as visual detection are all additional valid means of detecting a ship at sea. While the addition of solar arrays may increase the detection risk, the rewards gained from the arrays must be taken into account.

## VI. CONCLUSIONS AND RECOMMENDATIONS

### A. CONCLUSIONS

While this work is by no mean all-encompassing, a number of conclusions can be drawn. First, it is clear from the amount of fuel and money that can be saved that this is a cost-effective means of power generation at sea, even taking into account the up-front purchase and installation costs. These up-front costs would be recouped in a matter of years, providing potentially decades of savings. Additionally, the impact of fuel savings will be felt immediately. This savings is two-fold: monetary and environmental. Based on a yearly fuel savings of 51,800 gallons of fuel for a *San Antonio* class ship that spends 185 days at sea, a reduction of 532 metric tons can be made in the Navy's carbon footprint [30].

From a practical stand-point, there is nothing that prevents this type of system from being implemented. The added weight from the solar cells is very small; especially when compared to the amount of stores, fuel, and provisions that are loaded every time a ship gets underway. Additionally, the space and weight needed for a fuel cell system of appropriate capacity would not be inhibitive either.

The results from the experiments into tactical factors raise some concerns. The increase in RCS coupled with a large IR signature makes a ship more detectable. However, a ship's ability to be detected must be looked at in whole, factoring in all possible means of detection including visual, acoustic, EM, etc. When considered in this fashion, perhaps the increases in the two areas investigated do not make much difference. Further testing would be required to fully determine what effect a solar power system would have on a surface combatant.

Overall, this research demonstrates that an opportunity exists for the Navy to both save money and fuel and lessen its impact on the environment through the use of solar power aboard its ships.

## **B. RECOMMENDATIONS FOR FUTURE WORK**

Based on the research conducted in this work and the conclusions drawn, there are a number of areas that are worthy of future work. These include:

- Conducting simulations or modeling to determine what effects on ships' characteristics (displacement, draft, speed, etc.) the addition of solar panels and energy storage systems would actually have.
- Conducting real-world testing and analysis of the effects that solar panels have on the RCS and IR signature of surface combatants in order to verify or disprove the experimental data gathered in this work.
- Outfitting a test ship with a solar panel – energy storage system in order to gain real-world experience and data in order to verify or disprove the theoretical data presented in this work.

In addition to the above recommendations, research could be conducted into more durable coatings for the cells to help them withstand the rigors of a surface combatant at sea. Finally, this work would be equally applicable to the Navy's fleet of non-combatants such as supply ships, hospital ships, and oilers. These ships may offer additional opportunities for cost and fuel savings without having to take into account tactical factors such as RCS and IR signature or operational considerations such as flight operations, especially if the Navy is unwilling to make sacrifices in the detectability of its surface combatants.

## LIST OF REFERENCES

- [1] P. Ewing, “SecNav: Cut half of oil use by 2020.” *Navy Times*. Oct. 14, 2009.
- [2] T. Takahashi, “Photovoltaic arrays: On the way to ‘emission-zero ships.’” Monohakobi Technology Institute (NYK Group), presented at *Ship Power Forum*, London, Feb. 2011.
- [3] B. Coxworth, World’s largest solar-powered boat completes its trip around the world. *Gizmag*, May 4, 2012. [Online] Available: <http://www.gizmag.com/turanor-planetsolar-solar-powered-boat-completes-trip/22421/> [Accessed July 15, 2012].
- [4] Liquid Robotics Federal, *SHARC SV2 Product Specifications*. Annapolis, MD: Liquid Robotics Federal, 2013.
- [5] Wikipedia, “Solar cells.” Jul. 2013. [Online]. Available: [http://en.wikipedia.org/wiki/Solar\\_cells](http://en.wikipedia.org/wiki/Solar_cells). [Accessed July 11, 2013].
- [6] A. S. Sedra and K. C. Smith, *Microelectronic circuits*, 5<sup>th</sup> ed. New York: Oxford University Press, 2004.
- [7] Wikipedia, “Electromagnetic radiation.” June 2013. [Online]. Available: [http://en.wikipedia.org/wiki/Electromagnetic\\_radiation](http://en.wikipedia.org/wiki/Electromagnetic_radiation). [Accessed July 15, 2013].
- [8] Wikipedia, “Air mass (solar energy).” April 2013. [Online]. Available: [http://en.wikipedia.org/wiki/Air\\_mass\\_\(solar\\_energy\)](http://en.wikipedia.org/wiki/Air_mass_(solar_energy)). [Accessed July 16, 2013].
- [9] “EC3240 renewable energy at military bases and for the warfighter,” class notes for EC3240, Dept. of Electrical and Computer Engineering, Naval Postgraduate School, Monterey, CA, summer 2013.
- [10] NATIONAL Oceanic and Atmospheric Administration, “Solar position calculator.” July 2013. [Online]. Available: <http://www.esrl.noaa.gov/gmd/grad/solcalc/azel.html>. [Accessed July 17, 2013].
- [11] Wikipedia, “Theory of solar cells.” July 2013. [Online]. Available: [http://en.wikipedia.org/wiki/Theory\\_of\\_solar\\_cells](http://en.wikipedia.org/wiki/Theory_of_solar_cells). [Accessed July 12, 2013].
- [12] D. S. Ginley and D. Caheem, *Fundamentals of Materials for Energy and Environmental Sustainability*. Cambridge, UK: Cambridge University Press, 2012.
- [13] Global Solar Energy, “Technology,” 2013. [Online]. Available: <http://www.globalsolar.com/company/technology>. [Accessed August 13, 2013].

- [14] National Renewable Energy Laboratory, “Best research-cell efficiencies,” 2013. [Online]. Available: [http://www.nrel.gov/ncpv/images/efficiency\\_chart.jpg](http://www.nrel.gov/ncpv/images/efficiency_chart.jpg). [Accessed August 13, 2013].
- [15] SoloPower, “SP3L specifications.” 2012. [Online]. Available: <http://solopower.com/products/solopower-sp3/>. [Accessed July 12, 2013].
- [16] Stephen Saunders, *Jane’s Fighting Ships 2009–2010* (112<sup>th</sup> ed.). Surrey, UK: Jane’s Information Group, 2009.
- [17] U.S. Pacific Fleet, *FY 14 Baseline Calculations—PACFLT*. Pearl Harbor, HI: U.S. Pacific Fleet, 2012.
- [18] U.S. Energy Information Administration, “Petroleum & other liquids spot prices,” 2013. [Online]. Available: [http://www.eia.gov/dnav/pet/pet\\_pri\\_spt\\_s1\\_d.htm](http://www.eia.gov/dnav/pet/pet_pri_spt_s1_d.htm). [Accessed August 27, 2013].
- [19] Naval Base San Diego, *Naval Base San Diego Shipboard Shore Energy Management Update*. San Diego, CA: Naval Base San Diego, 2013.
- [20] Naval Sea Systems Command, *Pacific Fleet Shipboard Incentivized Energy Conservation 1<sup>st</sup> Quarter Report, FY 2013*. Washington, DC: Naval Sea Systems Command (05Z1), 2013.
- [21] T. Loop, “Email correspondence,” personal email (August 14, 2013).
- [22] M. Solé, “MS series specifications sheet,” 2011. [Online]. Available: [http://www.miasole.com/sites/default/files/MiaSole\\_MS\\_Datasheet.pdf](http://www.miasole.com/sites/default/files/MiaSole_MS_Datasheet.pdf). [Accessed July 22, 2013].
- [23] A. Soopra, Telephone conversation (August 6, 2013).
- [24] H. A. Kiene, *Battery Technology Handbook* (2<sup>nd</sup> ed.). New York: CRC Press, 2003.
- [25] Wikipedia, “Flywheel.” July 2013. [Online]. Available: <http://en.wikipedia.org/wiki/Flywheel>. [Accessed July 20, 2013].
- [26] Wikipedia, “Flywheel energy storage.” July 2013. [Online]. Available: [http://en.wikipedia.org/wiki/Flywheel\\_energy\\_storage](http://en.wikipedia.org/wiki/Flywheel_energy_storage). [Accessed July 20, 2013].
- [27] Vycon, “Run times & specs,” 2012. [Online]. Available: [http://vyconenergy.com/pq/pages\\_pq/pqprod.htm](http://vyconenergy.com/pq/pages_pq/pqprod.htm). [Accessed July 22, 2013].
- [28] Peter Hoffman, *Tomorrow’s Energy: Hydrogen, Fuel Cells, and the Prospects of a Cleaner Planet*. Cambridge, MA: MIT Press, 2001.

- [29] Martin Streetly, *Jane's Radar & Electronic Warfare Systems 2005–2006* (17<sup>th</sup> ed.). Surrey, UK: Jane's Information Group, 2005.
- [30] Sustainable Shipping, Emissions calculation, 2013. [Online]. Available: <http://www.sustainableshipping.com/>.

THIS PAGE INTENTIONALLY LEFT BLANK

## **INITIAL DISTRIBUTION LIST**

1. Defense Technical Information Center  
Ft. Belvoir, Virginia
2. Dudley Knox Library  
Naval Postgraduate School  
Monterey, California