

REPORT DOCUMENTATION PAGE

Form Approved
OMB No. 0704-0188

Public reporting burden for this collection of information is estimated to average 1 hour per response, including the time for reviewing instructions, searching existing data sources, gathering and maintaining the data needed, and completing and reviewing this collection of information. Send comments regarding this burden estimate or any other aspect of this collection of information, including suggestions for reducing this burden to Department of Defense, Washington Headquarters Services, Directorate for Information Operations and Reports (0704-0188), 1215 Jefferson Davis Highway, Suite 1204, Arlington, VA 22202-4302. Respondents should be aware that notwithstanding any other provision of law, no person shall be subject to any penalty for failing to comply with a collection of information if it does not display a currently valid OMB control number. PLEASE DO NOT RETURN YOUR FORM TO THE ABOVE ADDRESS.

1. REPORT DATE (DD-MM-YYYY) 09/09/2013		2. REPORT TYPE Interim Research Performance Report (Monthly)		3. DATES COVERED (From - To) August 1 - August 31, 2013	
4. TITLE AND SUBTITLE Expeditionary Light Armor Seeding Development				5a. CONTRACT NUMBER	
				5b. GRANT NUMBER N00014-13-1-0219	
				5c. PROGRAM ELEMENT NUMBER	
6. AUTHOR(S) Shridhar Yarlagadda, Bazle Haque				5d. PROJECT NUMBER	
				5e. TASK NUMBER	
				5f. WORK UNIT NUMBER	
7. PERFORMING ORGANIZATION NAME(S) AND ADDRESS(ES) UNIVERSITY OF DELAWARE OFFICE OF THE VICE PROVOST FOR RESEARCH 220 HULLIHEN HALL NEWARK, DE 19716-0099				8. PERFORMING ORGANIZATION REPORT NUMBER MONTHLY-5	
9. SPONSORING / MONITORING AGENCY NAME(S) AND ADDRESS(ES) Office of Naval Research 875 North Randolph Street Arlington, VA 22203-1995				10. SPONSOR/MONITOR'S ACRONYM(S) ONR	
				11. SPONSOR/MONITOR'S REPORT NUMBER(S)	
12. DISTRIBUTION / AVAILABILITY STATEMENT Approved for Public Release; distribution is Unlimited.					
13. SUPPLEMENTARY NOTES					
14. ABSTRACT -Quarter-symmetric model is used in AutoDyn to simulate DoP experiments on aluminum targets and ceramic-faced aluminum targets with .30cal AP M2 projectile using SPH elements. -Model validation runs were conducted based on the DoP experiments described in reference - ARL-TR-2219, 2000. -Boundary conditions were modified in order to achieve better data agreement -Further analysis will be conducted to determine the effect of material properties on DoP					
15. SUBJECT TERMS .30cal AP M2 Projectile, 762x39 PS Projectile, SPH, Aluminum 5083, SiC, DoP Experiments, AutoDyn Simulations					
16. SECURITY CLASSIFICATION OF: UU			17. LIMITATION OF ABSTRACT UU	18. NUMBER OF PAGES 27	19a. NAME OF RESPONSIBLE PERSON Shridhar Yarlagadda
a. REPORT	b. ABSTRACT	c. THIS PAGE			19b. TELEPHONE NUMBER (include area code) 302-831-4941

20130916045



**MONTHLY REPORT
AUGUST 2013**

**MODELING AND SIMULATION OF CERAMIC
ARRAYS TO IMPROVE BALLAISTIC
PERFORMANCE**

MONTHLY REPORT FOR AUGUST 2013



- Quarter-symmetric model is used in AutoDyn to simulate DoP experiments on aluminum targets and ceramic-faced aluminum targets with .30cal AP M2 projectile using SPH elements.
- Model validation runs were conducted based on the DoP experiments described in reference - ARL-TR-2219, 2000.
- Boundary conditions were modified in order to achieve better data agreement
- Further analysis will be conducted to determine the effect of material properties on DoP

DOP OF .30cal PROJECTILE INTO MONOLITHIC ALUMINUM (Ref: ARL-TR-2219, 2000.)

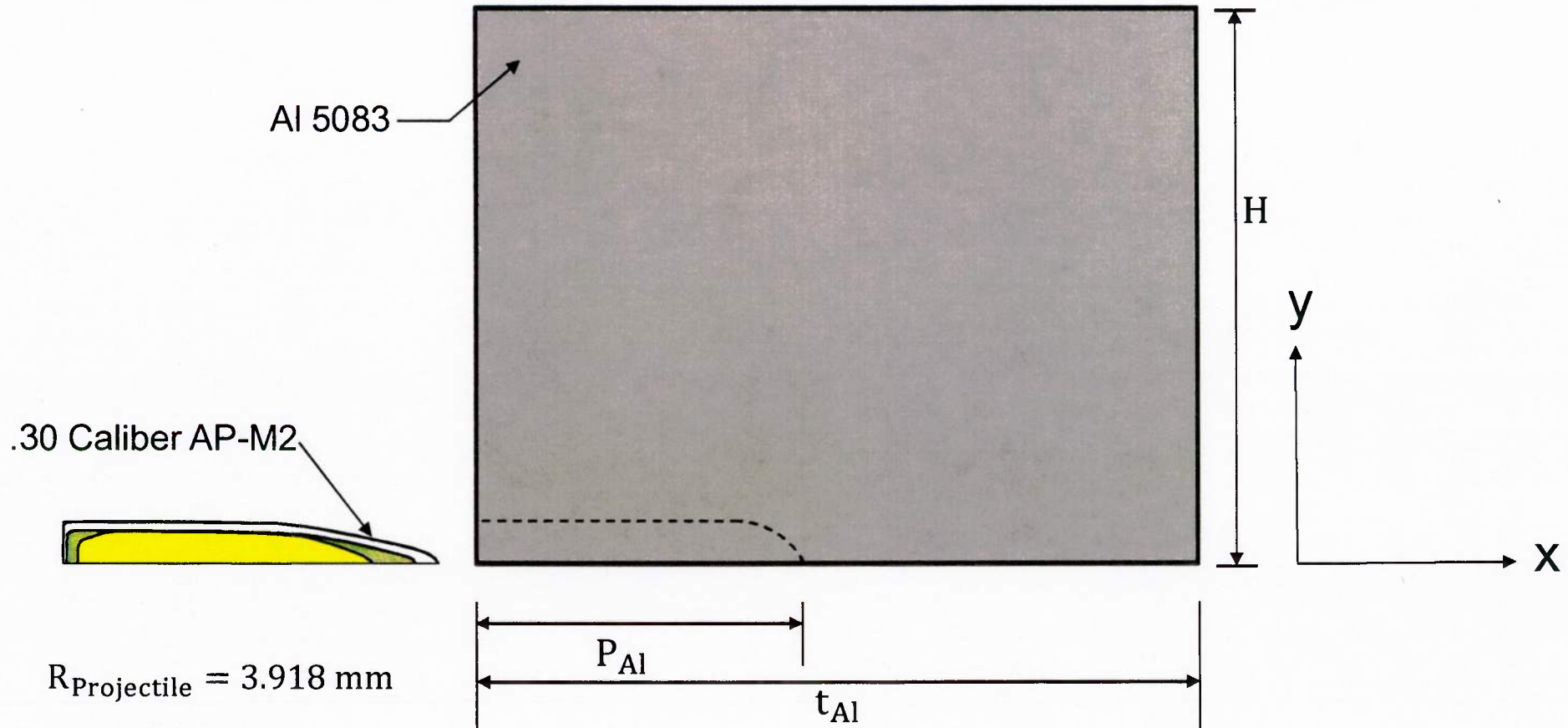

$$R_{\text{Projectile}} = 3.918 \text{ mm}$$

$$t_{Al} = 76.2 \text{ mm}$$

$$H = 20.0 \text{ mm}$$

$$V_p = 400 - 900 \text{ m/s}$$

DOP OF .30cal PROJECTILE INTO CERAMIC-FACED TARGET (Ref: ARL-TR-2219, 2000.)

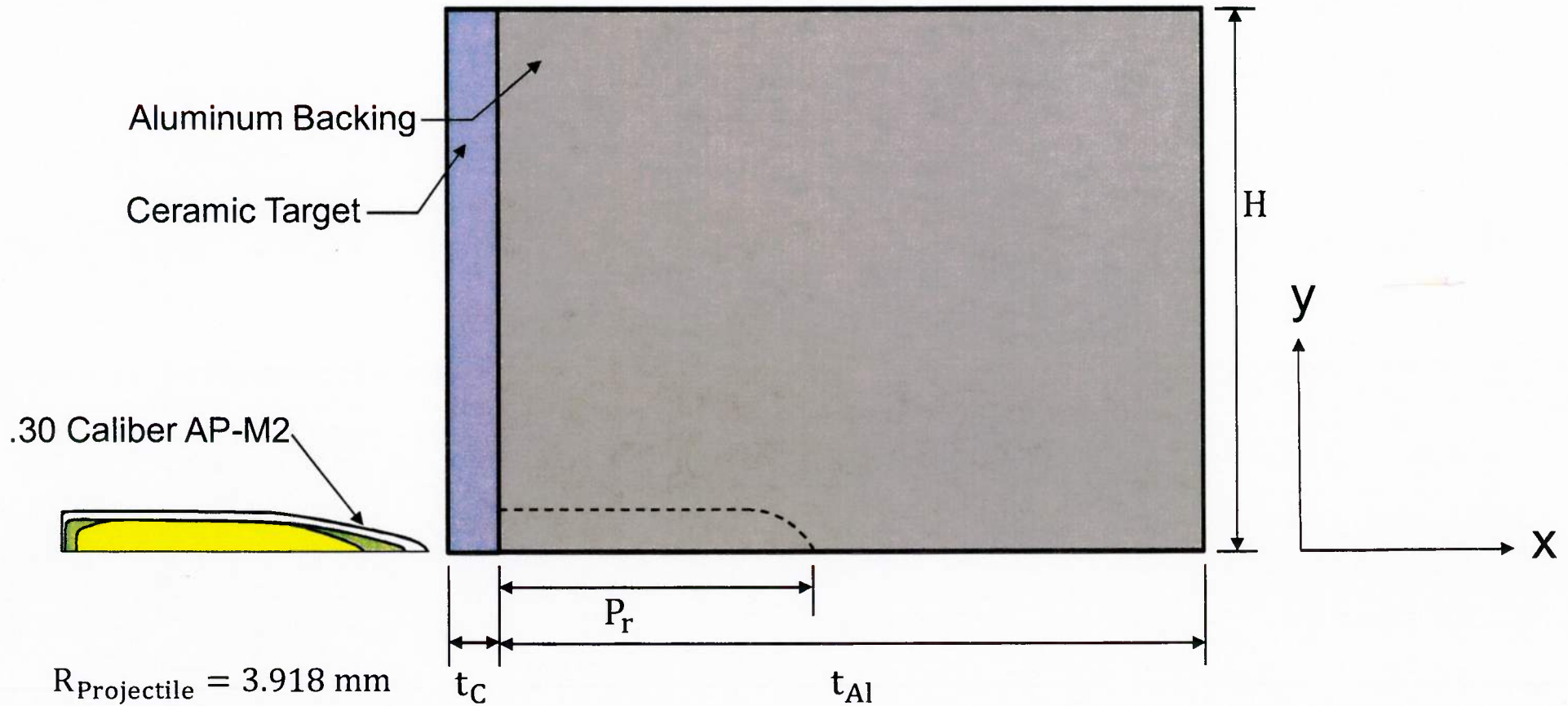

$$R_{\text{Projectile}} = 3.918 \text{ mm}$$

$$t_C = 1.25, 2.50, 3.75, 5.00 \text{ mm}$$

$$t_{Al} = 76.2 \text{ mm}$$

$$H = 20.0 \text{ mm}$$

$$V_p = 841 \pm 15 \text{ m/s}$$

30AP-M2 PROJECTILE MASS PROPERTIES

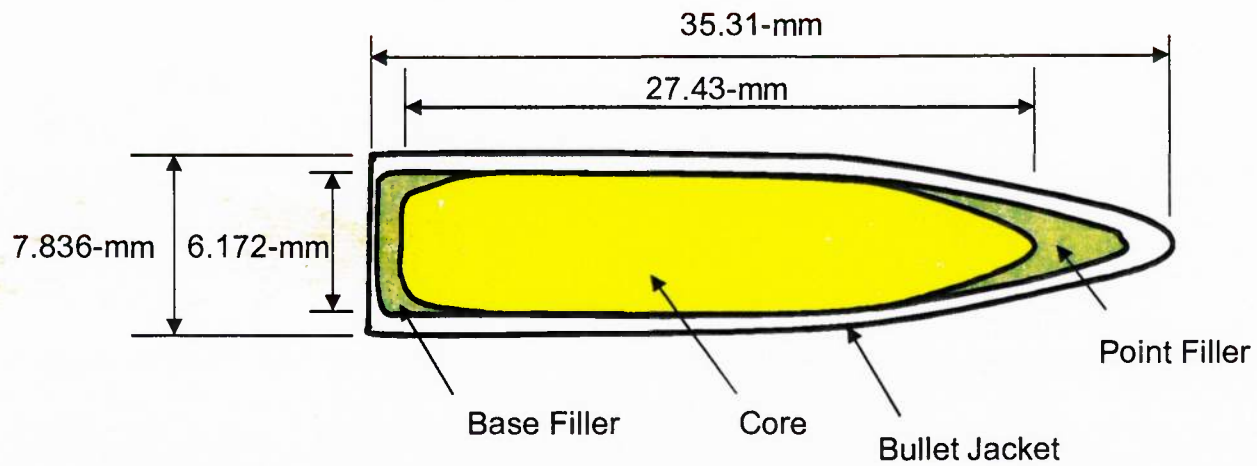

Component	Material	Weight (g)
Jacket	Gilding Metal	4.2
Core	Hardened Steel - RC 63	5.3
Point Filler	Lead	0.8
Base Filler	Lead	0.5
Total Weight		10.8

SOLID MODEL OF .30cal AP M2 PROJECTILE

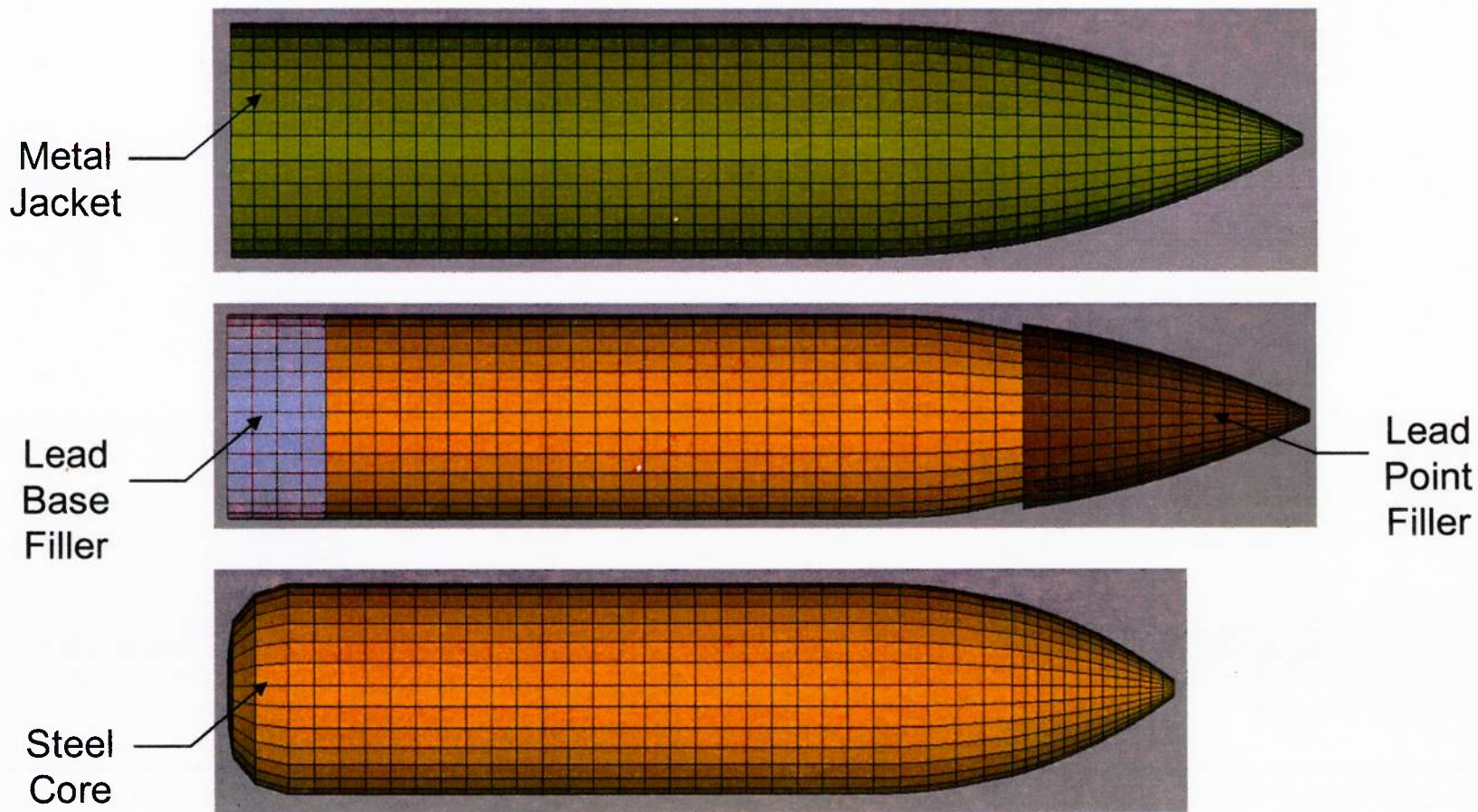

MATERIAL PROPERTIES – AI 5083



Experimental AI 5083

	AI 5083
Density (g/cm ³)	2.65
Tensile Strength (MPa)	377.1
Yield Strength (MPa)	318.5
Elongation (%)	9.3

Ref:
 MTL TR-86-14, 1986.
 ARL-TR-2219, 2000.

AutoDyn AI 5083

Equation of State	Linear
Reference density	2.70000E+00 (g/cm ³)
Bulk Modulus	5.83300E+11 (ubar)
Reference Temperature	2.93000E+02 (K)
Specific Heat	9.10000E+06 (erg/gK)
Thermal Conductivity	0.00000E+00 ()
Strength	Johnson Cook
Shear Modulus	2.69200E+11 (ubar)
Yield Stress	1.67000E+09 (ubar)
Hardening Constant	5.96000E+09 (ubar)
Hardening Exponent	5.51000E-01 (none)
Strain Rate Constant	1.00000E-03 (none)
Thermal Softening Exponent	8.59000E-01 (none)
Melting Temperature	8.93000E+02 (K)
Ref. Strain Rate (/s)	1.00000E+00 (none)
Strain Rate Correction	1st Order
Failure	None
Erosion	None
Material Cutoffs	-
Maximum Expansion	1.00000E-01 (none)
Minimum Density Factor	1.00000E-05 (none)
Minimum Density Factor (SPH)	2.00000E-01 (none)
Maximum Density Factor (SPH)	3.00000E+00 (none)
Minimum Soundspeed	1.00000E-04 (cm/s)
Maximum Soundspeed (SPH)	1.01000E+20 (cm/s)
Maximum Temperature	1.00000E+16 (K)

MATERIAL PROPERTIES - SiC



AutoDyn SiC

Experimental SiC

	SiC
Density (g/cm ³)	3.20
Elastic Modulus (GPa)	455
Shear Modulus (GPa)	195
Longitudinal Wave Velocity (km/s)	12.3
Poisson's Ratio	0.14
Hardness (kg/mm ²)	2700
Compressive Strength (MPa)	3410

Ref:
ARL-TR-2219, 2000.

Equation of State	Polynomial
Reference density	3.21500E+00 (g/cm ³)
Bulk Modulus A1	2.20000E+12 (ubar)
Parameter A2	3.61000E+12 (ubar)
Parameter A3	0.00000E+00 (ubar)
Parameter B0	0.00000E+00 (none)
Parameter B1	0.00000E+00 (none)
Parameter T1	2.20000E+12 (ubar)
Parameter T2	0.00000E+00 (ubar)
Reference Temperature	2.93000E+02 (K)
Specific Heat	0.00000E+00 (erg/gK)
Thermal Conductivity	0.00000E+00 ()
Strength	Johnson-Holmquist
Shear Modulus	1.93500E+12 (ubar)
Model Type	Segmented (JH1)
Hugoniot Elastic Limit, HEL	1.17000E+11 (ubar)
Intact Strength Constant, S1	7.10000E+10 (ubar)
Intact Strength Constant, P1	2.50000E+10 (ubar)
Intact Strength Constant, S2	1.22000E+11 (ubar)
Intact Strength Constant, P2	1.00000E+11 (ubar)
Strain Rate Constant, C	9.00000E-03 (none)
Max. Fracture Strength, SFMAX	1.30000E+10 (ubar)
Failed Strength Constant, ALPHA	4.00000E-01 (none)
Failure	Johnson Holmquist
Hydro Tensile Limit	-7.50000E+09 (ubar)
Model Type	Segmented (JH1)
Damage Constant, EFMAX	1.20000E+00 (none)
Damage Constant, P3	9.97500E+11 (ubar)
Bulking Constant, Beta	1.00000E+00 (none)
Damage Type	Instantaneous (JH1)
Tensile Failure	Hydro (Pmin)

AUTODYN QUARTER-SYMMETRIC MODEL

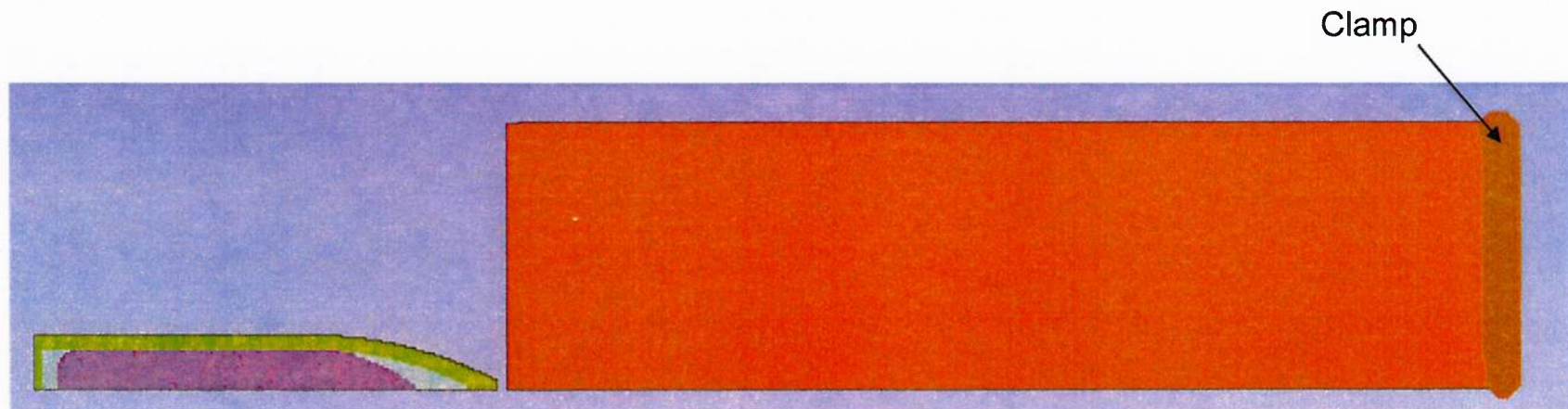

- Smoothed-particle hydrodynamics (SPH) used for all parts
- Target size = 0.50-mm totaling 351k elements
- Clamp boundary condition used at end of aluminum to secure the target

SHOT NO. 3002, $V=834$ m/s, $t_c=1.25$ mm

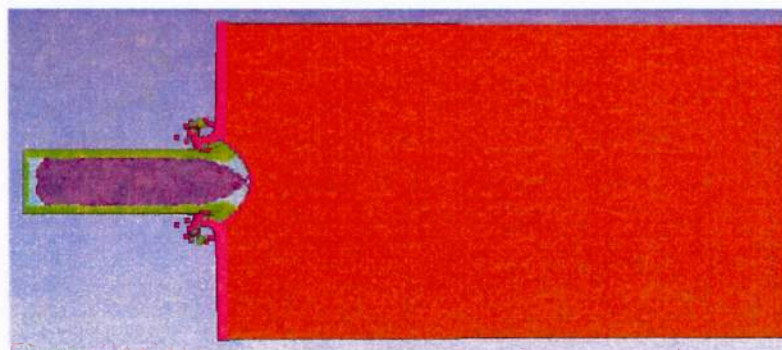

$t = 0.01587$ ms

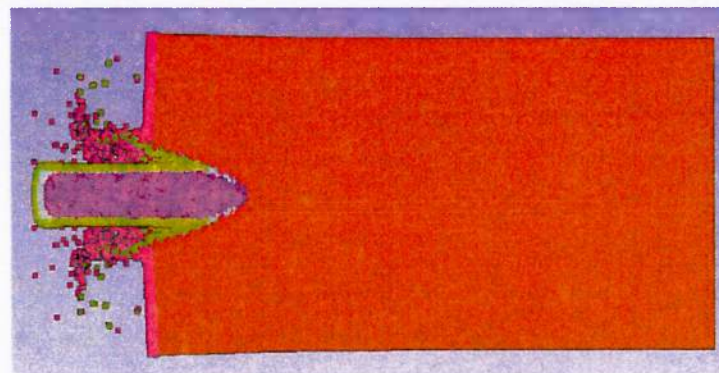

$t = 0.03314$ ms

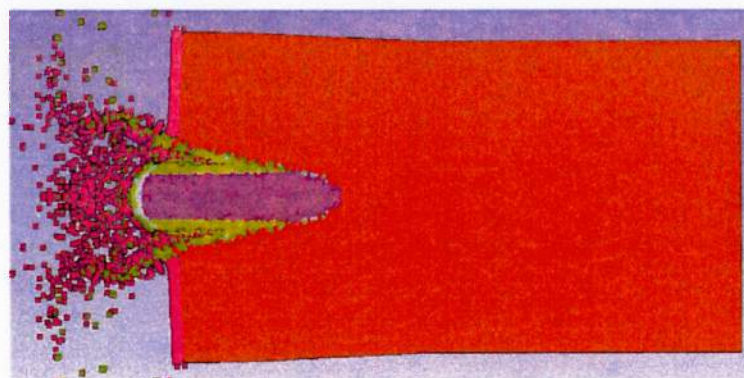

$t = 0.04902$ ms

SHOT NO. 3002, $V=834$ m/s, $t_c=1.25$ mm

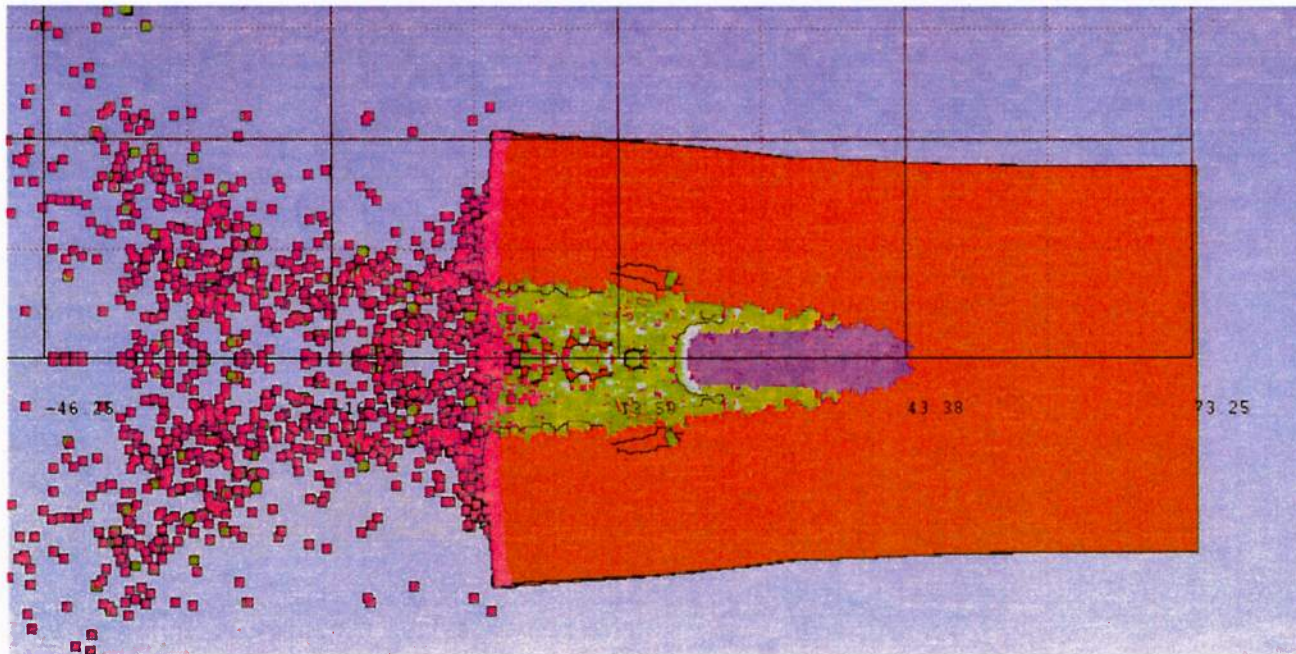

$t = 0.1144$ ms

AutoDyn DOP = 43.38 mm

Experimental DOP = 40.1 mm

SHOT NO. 3002 PROJECTILE KINETIC ENERGY vs. TIME

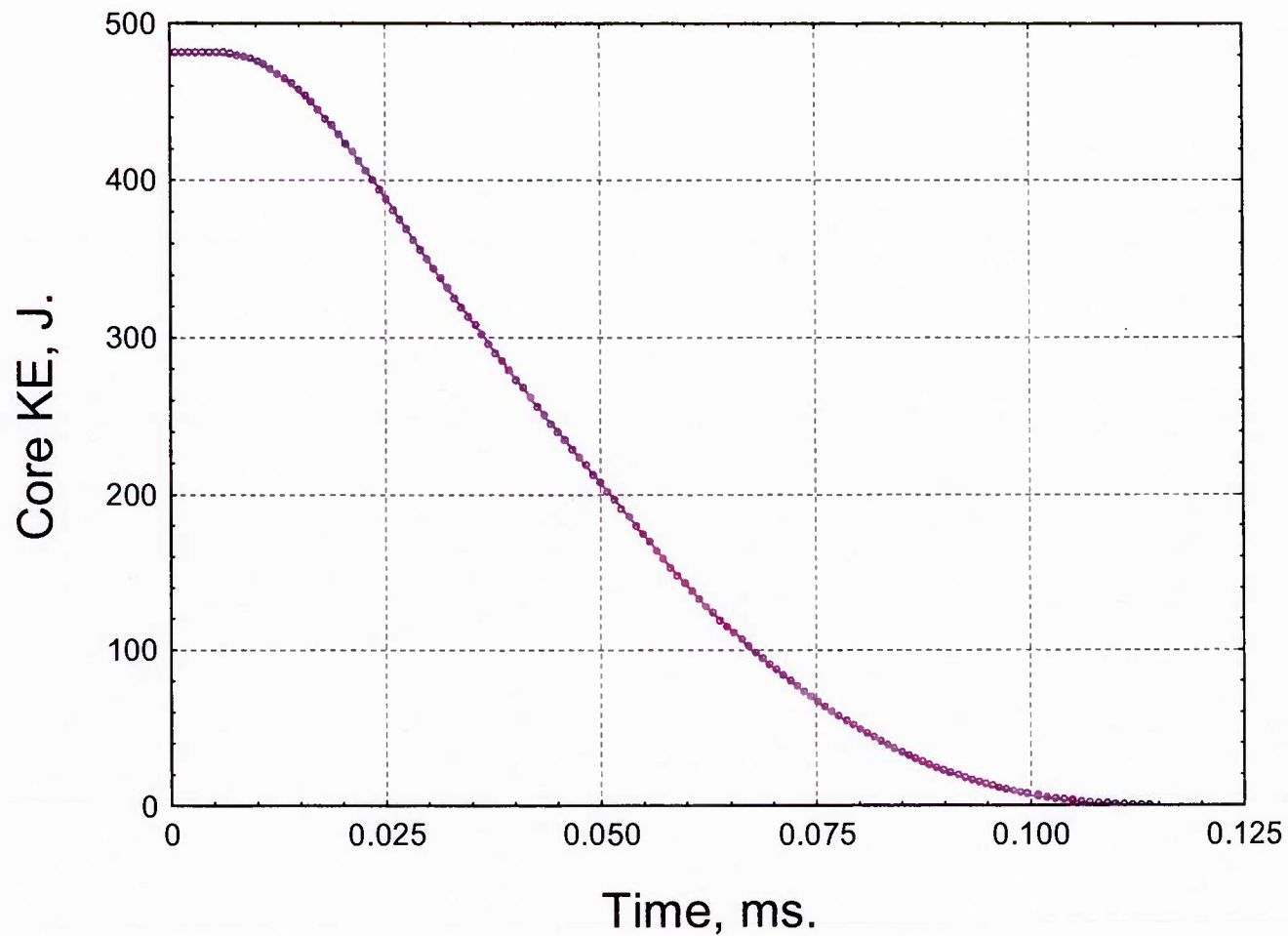

QUARTER-SYMMETRIC AUTODYN MODEL

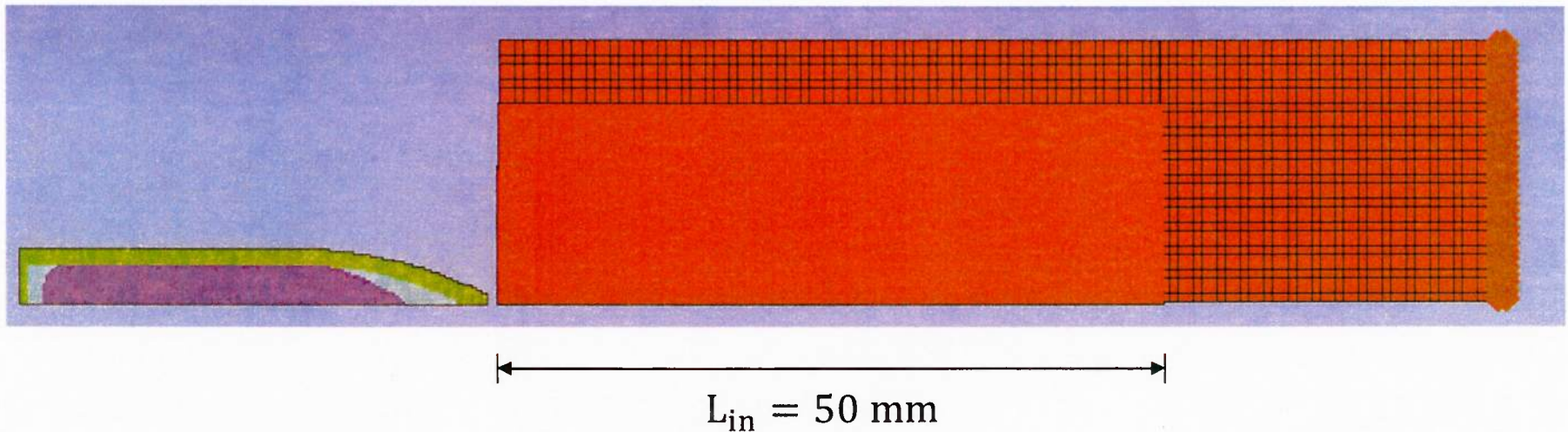

- Smoothed-particle hydrodynamics (SPH) used
- Element zoning necessary for computation
- Projectile and inside target zone element size = 0.30-mm
- 343k total elements
- Clamp boundary condition used at end of target

TARGET ELEMENT ZONING – FRONT VIEW



FRONT VIEW

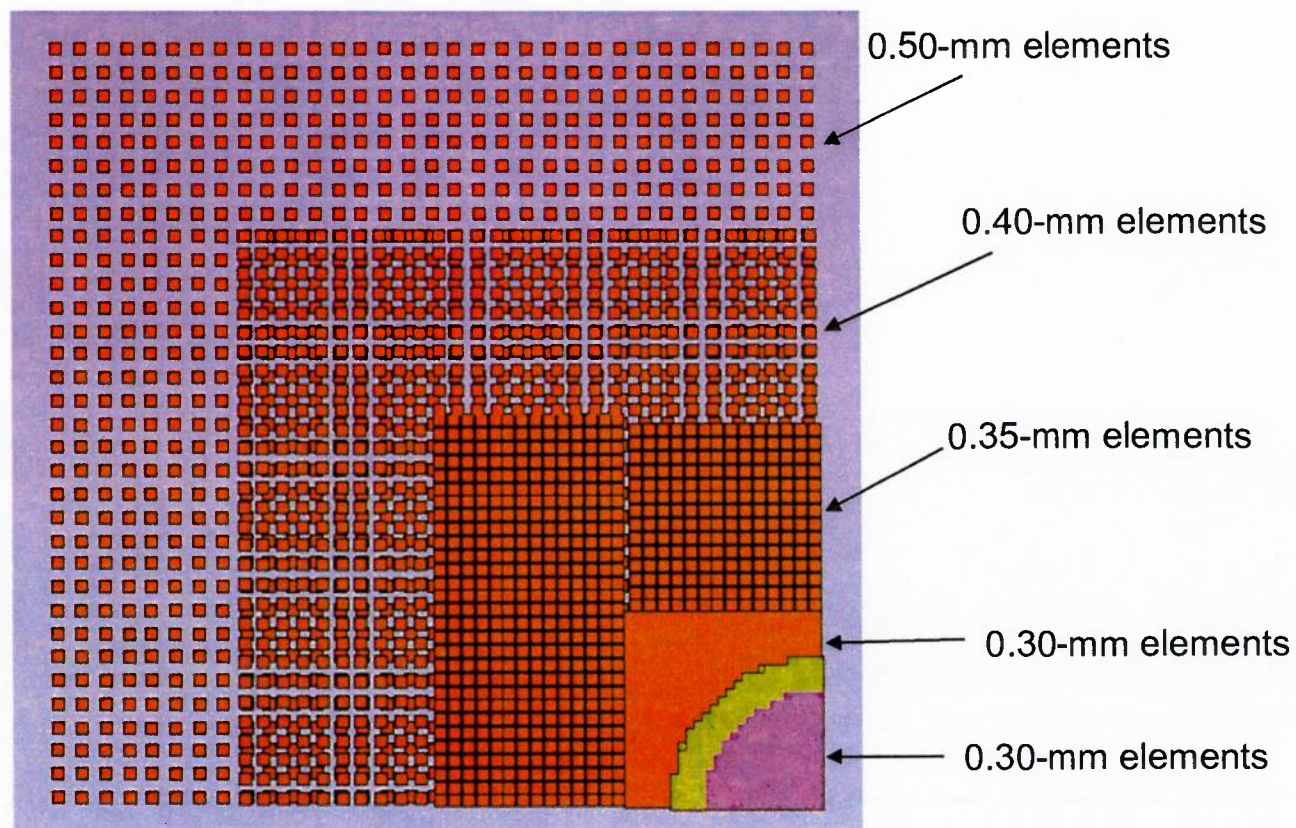

Total: 343k elements

SHOT NO. 2784, $V=829$ m/s



Large Deflection

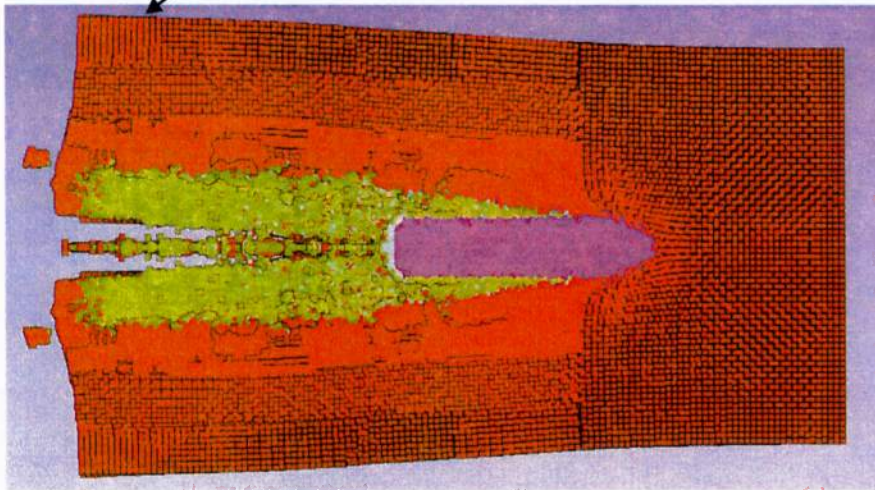

Trial 1: Zoned Mesh Target

DoP = 56.75 mm

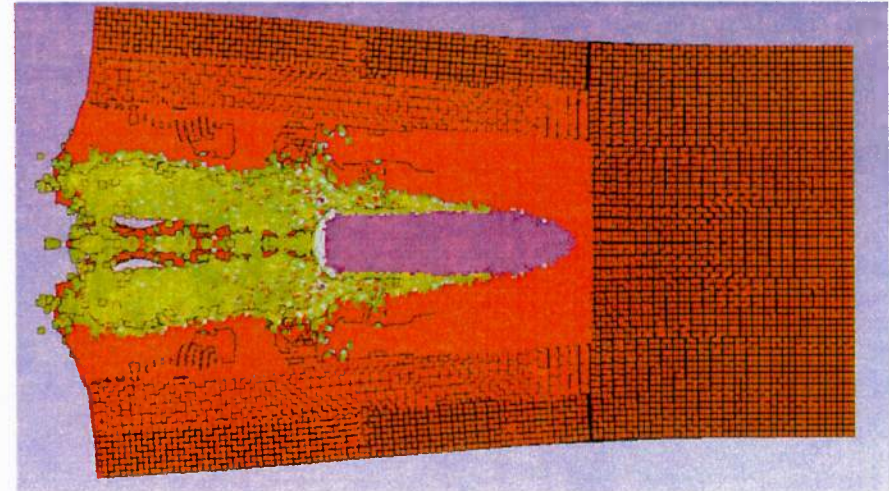

Trial 2: Increased Al yield strength
(318.5 MPa)

DoP = 50.93 mm

Literature DoP = 44.4 mm

Problem: Stress wave propagation at border creates large target deflections

MODIFIED QUARTER-SYMMETRIC MODEL

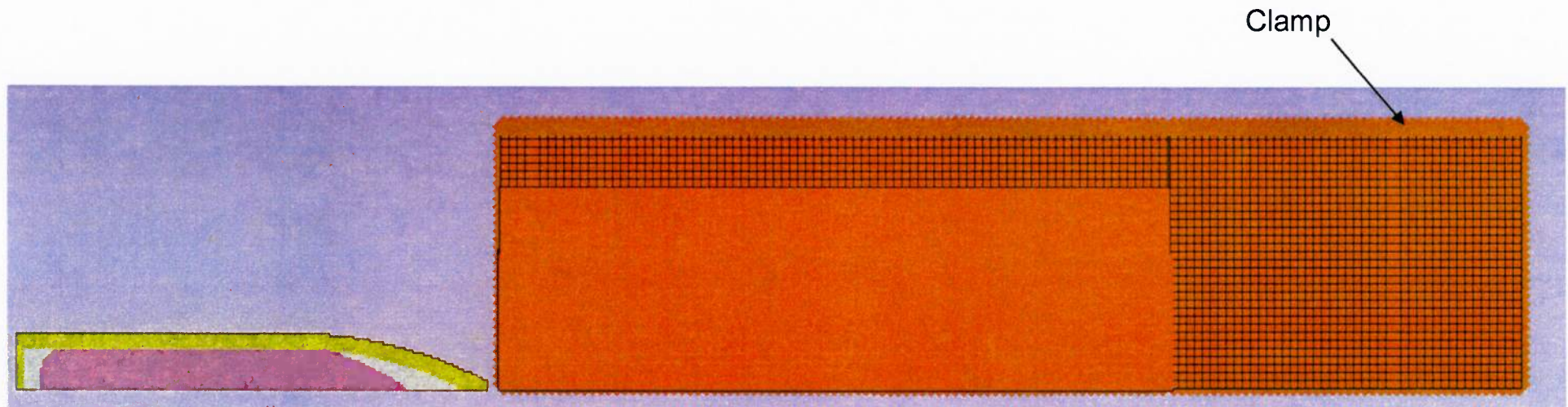

Adding clamp boundary conditions to the outer faces of the target reduces the effect of the stress wave propagation on target failure

FULLY CLAMPED MODEL CROSS-SECTION



FRONT VIEW

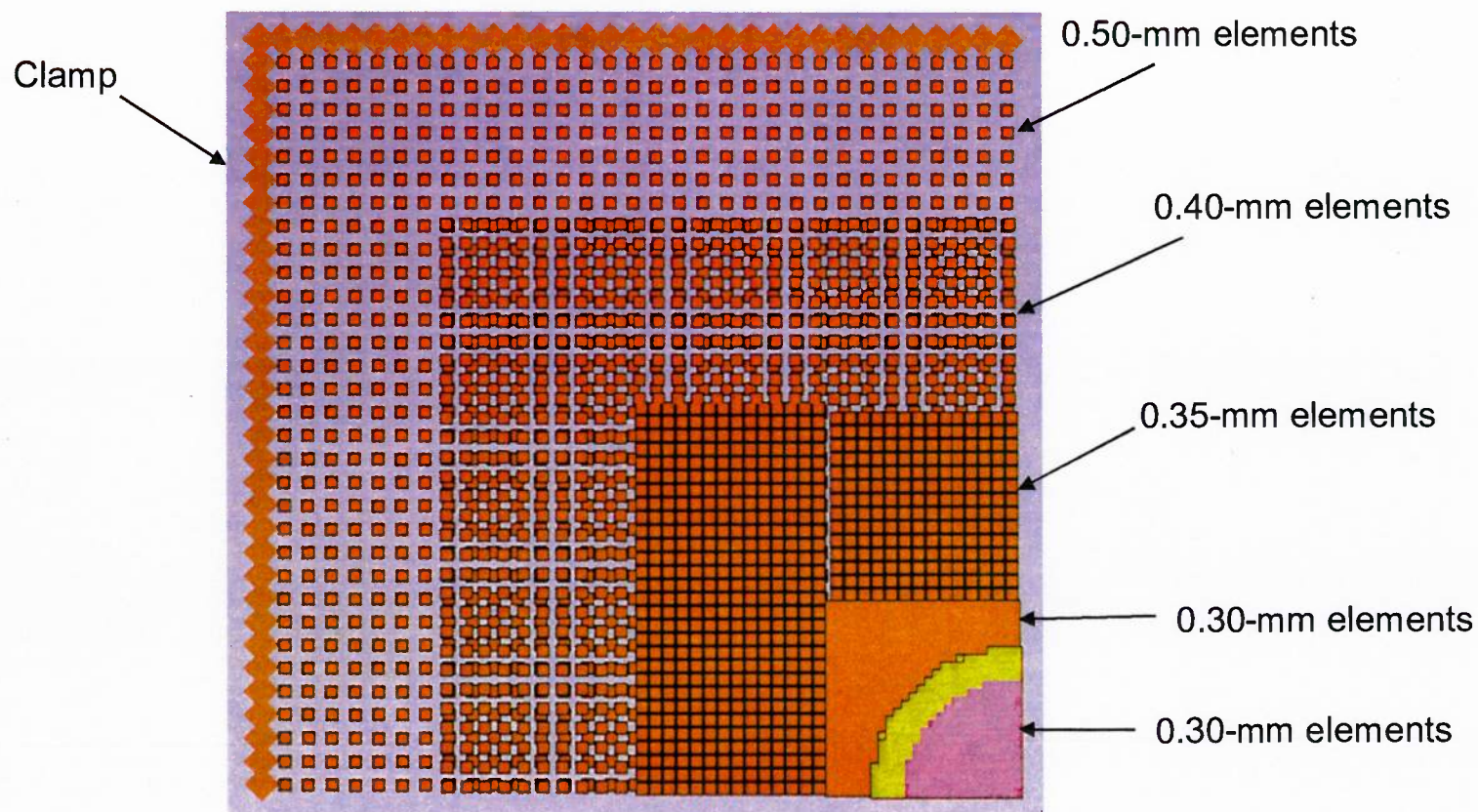

Total: 343k elements

SHOT NO. 2784, $V=829$ m/s

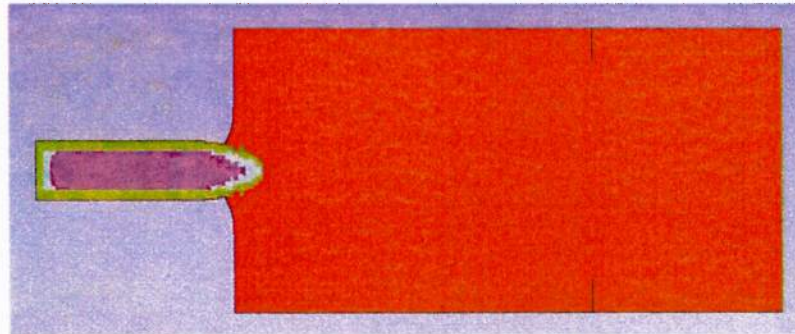

$t = 0.010$ ms

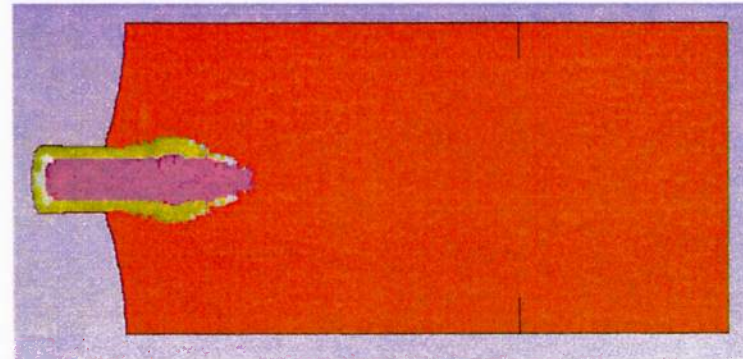

$t = 0.022$ ms

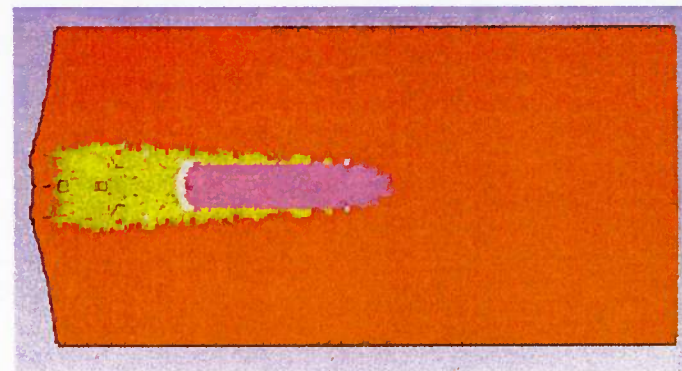

$t = 0.101$ ms

Measured DoP = 41.30 mm

Literature DoP = 44.40 mm

Uncertainty = 6.98%

SHOT NO. 2784 PROJECTILE KINETIC ENERGY vs. TIME

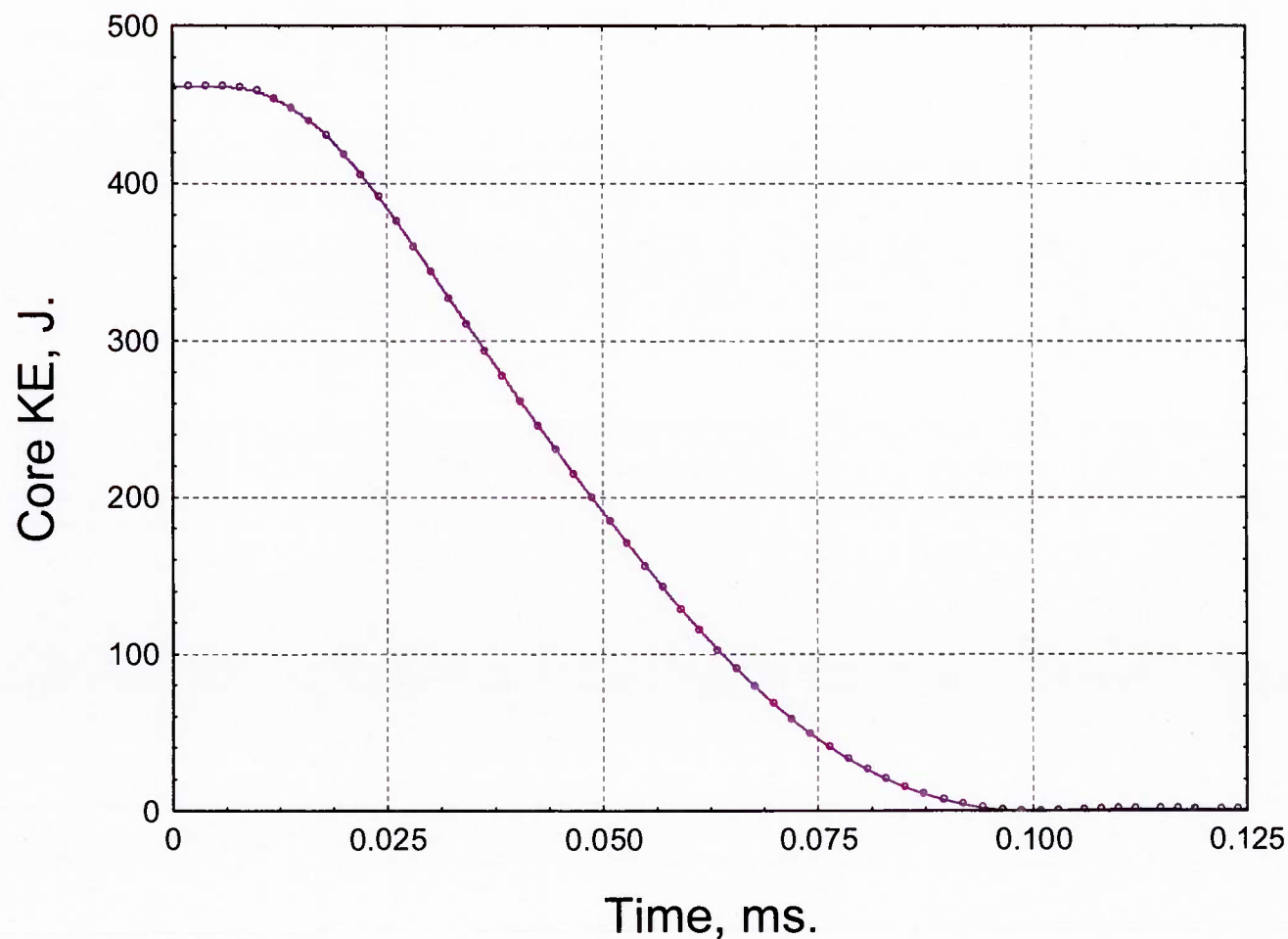

SHOT NO. 3048, $V=829$ m/s, $t_c=5.08$ mm



FRONT VIEW

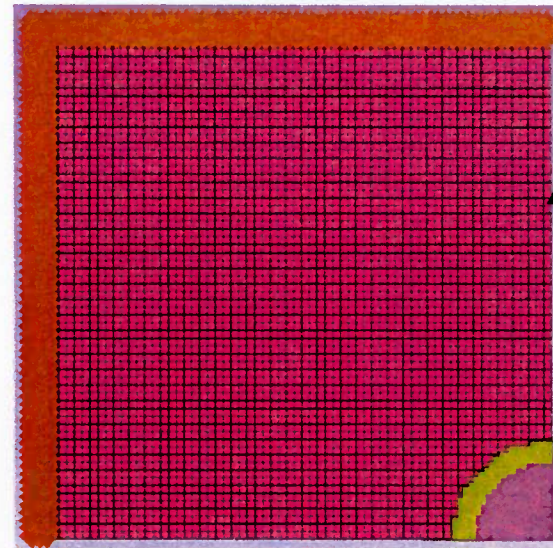

0.30 mm SiC elements

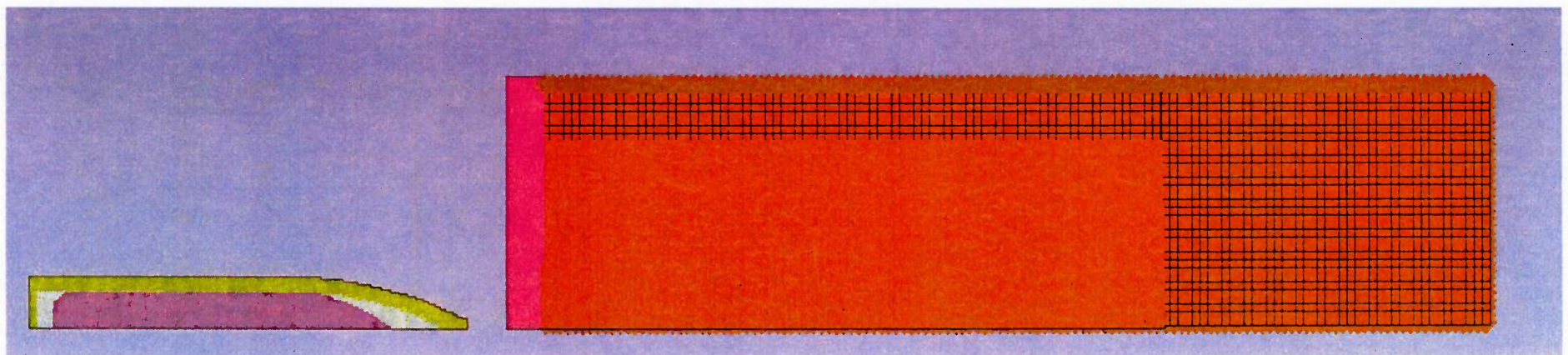

t_c

SHOT NO. 3048, $V=829$ m/s, $t_c=5.08$ mm

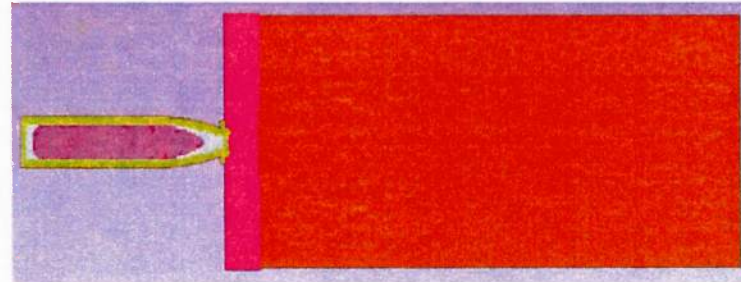

$t = 0.0047$ ms

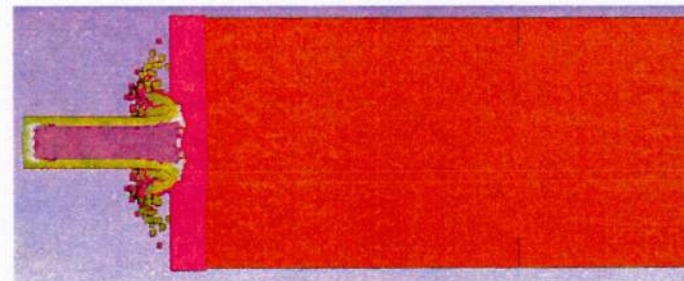

$t = 0.0025$ ms

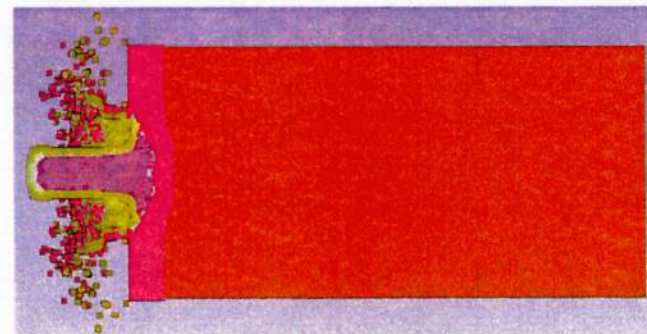

$t = 0.0435$ ms

Projectile defeated in SiC tile, no DoP. Agrees with literature.

SHOT NO. 3048 PROJECTILE KINETIC ENERGY vs. TIME

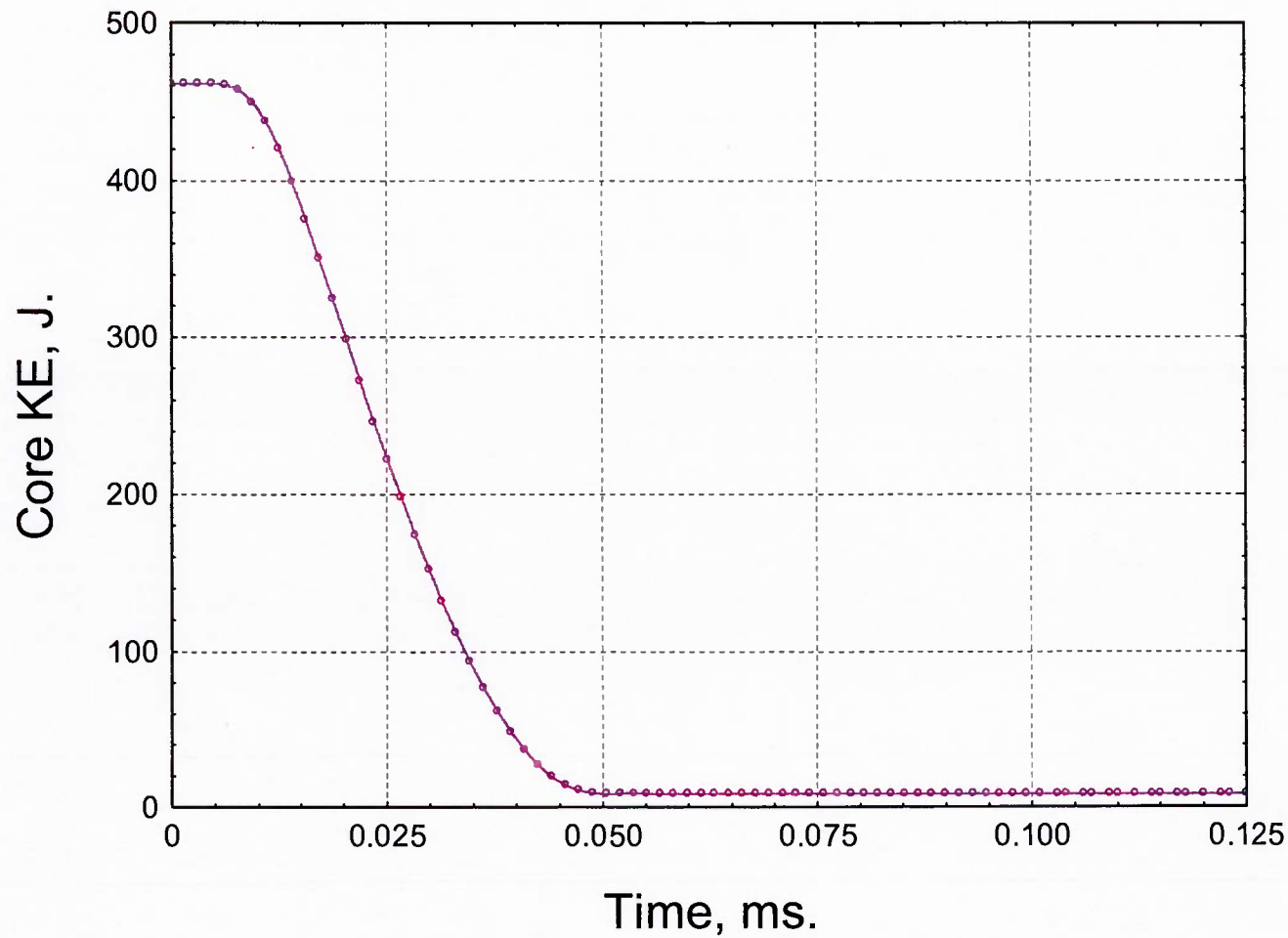

SHOT NO. 3005, $V=843$ m/s, $t_c=2.59$ mm



$t = 0.016$ ms

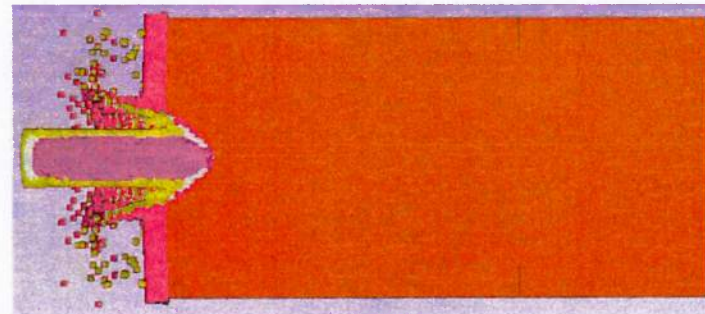

$t = 0.025$ ms

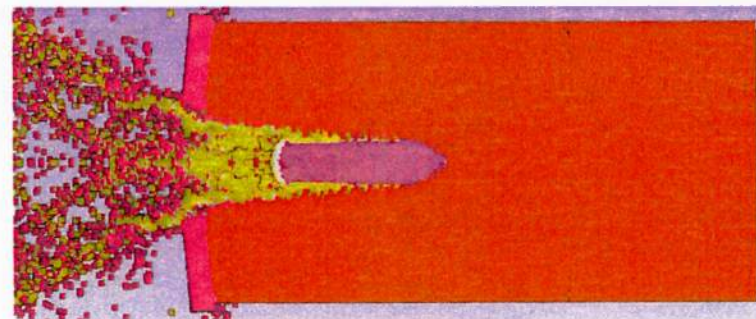

$t = 0.101$ ms

Measured DoP = 27.40 mm

Literature DoP = 22.80 mm

Uncertainty= 20.2%

Conclusion: Material properties of SiC may need to be adjusted to achieve better data agreement

SHOT NO. 3005 PROJECTILE KINETIC ENERGY vs. TIME

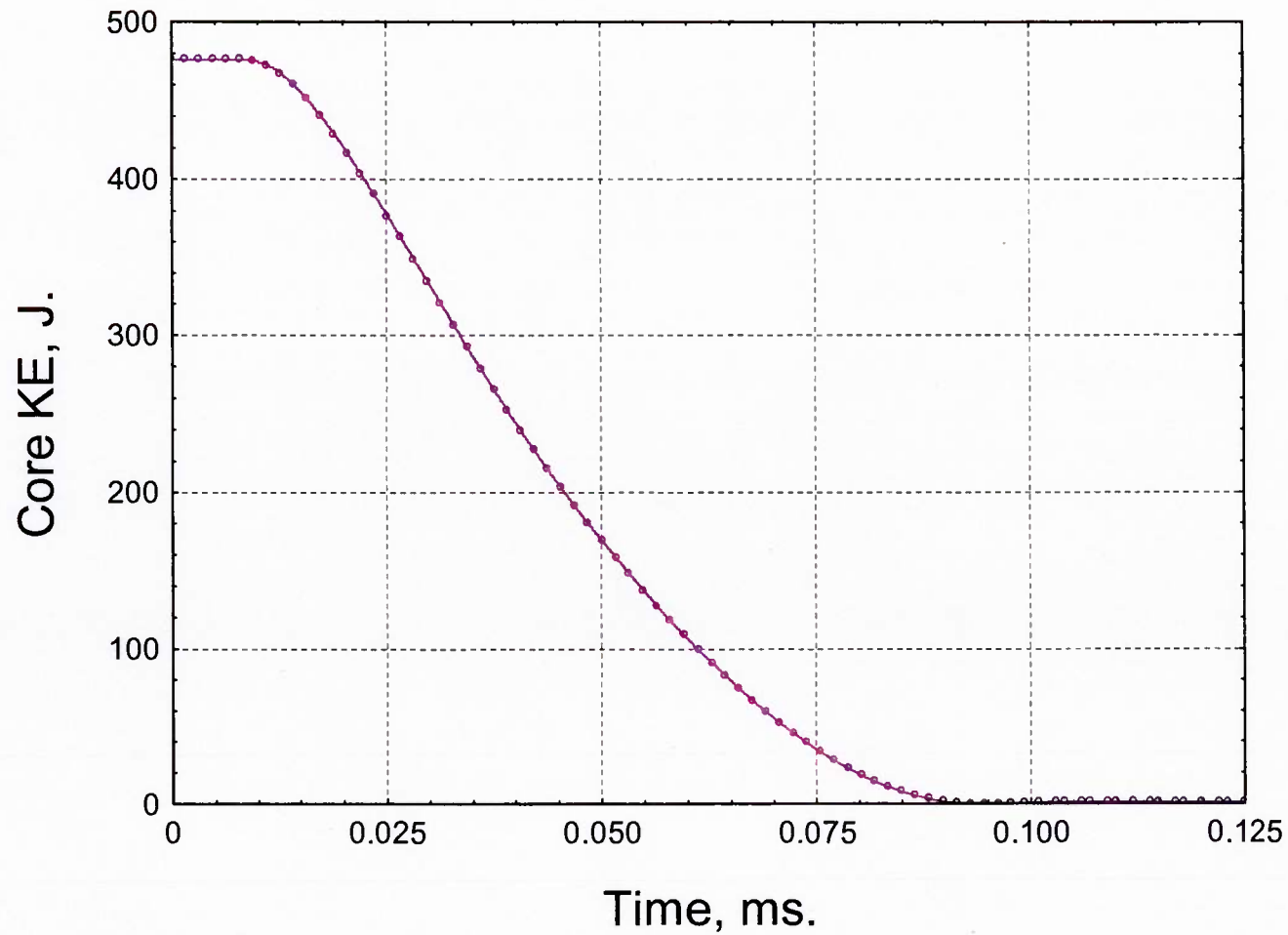

PENETRATION INTO MONOLITHIC ALUMINUM vs. STRIKE VELOCITY (Ref: ARL-TR-2219, 2000.)

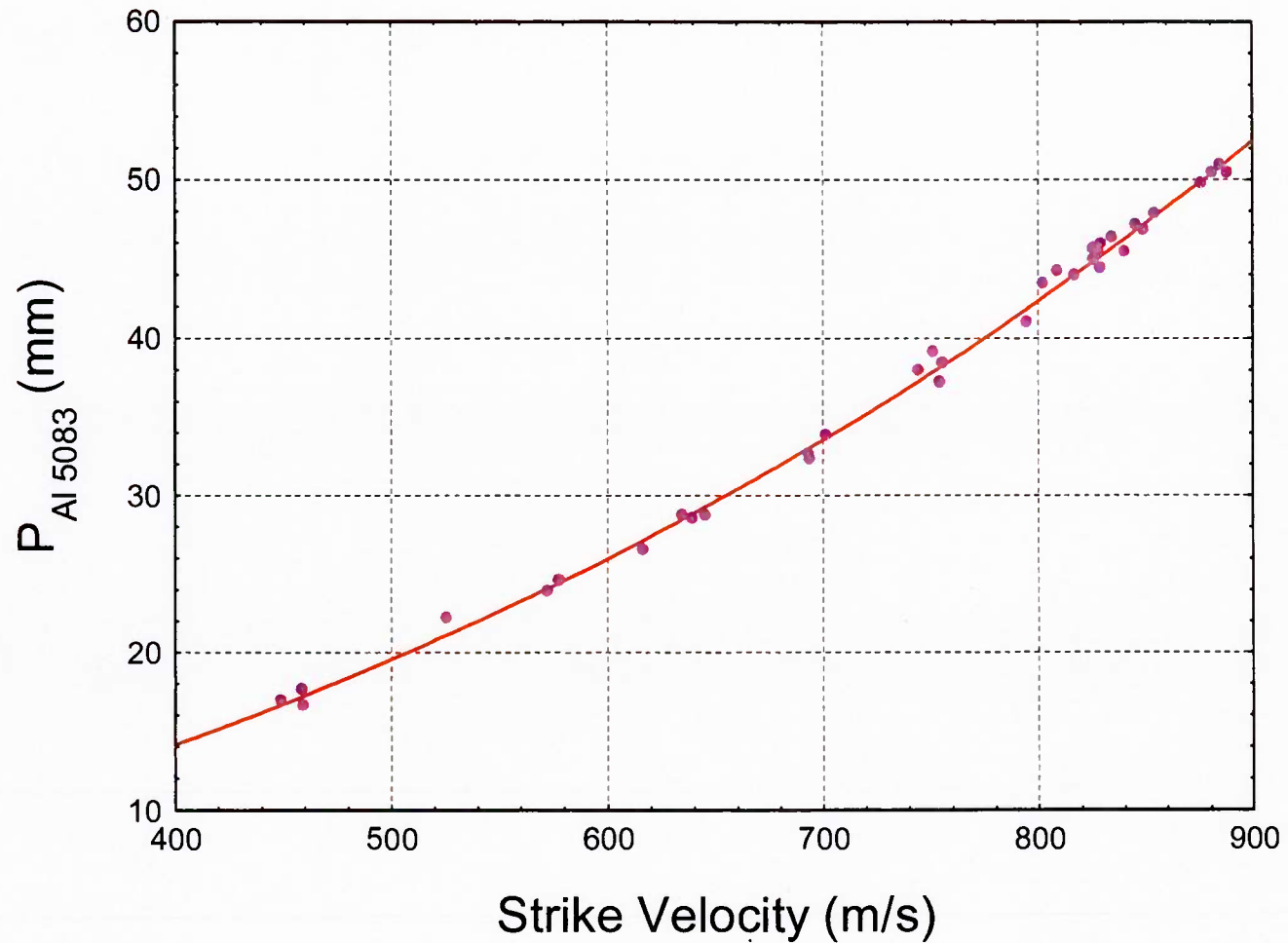

RESIDUAL PENETRATION AREAL DENSITY vs. CERAMIC AREAL DENSITY (Ref: ARL-TR-2219, 2000.)

