



ARMY COMMUNICATOR

Approved for public release;
distribution is unlimited.
Headquarters,
Department of the Army

Voice of the Signal Regiment PB 11-12-4 2012 Vol. 37 No. 4



SIGNAL PROFESSION TRANSFORMATION



PLUS:

- *Signal career paths changing*
- *NTC offers success tips for Battalion Signal Officers*
- *Web-based mission control*

Report Documentation Page

Form Approved
OMB No. 0704-0188

Public reporting burden for the collection of information is estimated to average 1 hour per response, including the time for reviewing instructions, searching existing data sources, gathering and maintaining the data needed, and completing and reviewing the collection of information. Send comments regarding this burden estimate or any other aspect of this collection of information, including suggestions for reducing this burden, to Washington Headquarters Services, Directorate for Information Operations and Reports, 1215 Jefferson Davis Highway, Suite 1204, Arlington VA 22202-4302. Respondents should be aware that notwithstanding any other provision of law, no person shall be subject to a penalty for failing to comply with a collection of information if it does not display a currently valid OMB control number.

1. REPORT DATE 2012	2. REPORT TYPE	3. DATES COVERED 00-00-2012 to 00-00-2012			
4. TITLE AND SUBTITLE Army Communicator. Volume 37, Number 4. Winter 2012		5a. CONTRACT NUMBER			
		5b. GRANT NUMBER			
		5c. PROGRAM ELEMENT NUMBER			
6. AUTHOR(S)		5d. PROJECT NUMBER			
		5e. TASK NUMBER			
		5f. WORK UNIT NUMBER			
7. PERFORMING ORGANIZATION NAME(S) AND ADDRESS(ES) U.S. Army Signal Center of Excellence, Army Communicator, Signal Towers (Building 29808), Room 713, Fort Gordon, GA, 30905-5301		8. PERFORMING ORGANIZATION REPORT NUMBER			
9. SPONSORING/MONITORING AGENCY NAME(S) AND ADDRESS(ES)		10. SPONSOR/MONITOR'S ACRONYM(S)			
		11. SPONSOR/MONITOR'S REPORT NUMBER(S)			
12. DISTRIBUTION/AVAILABILITY STATEMENT Approved for public release; distribution unlimited					
13. SUPPLEMENTARY NOTES					
14. ABSTRACT					
15. SUBJECT TERMS					
16. SECURITY CLASSIFICATION OF:			17. LIMITATION OF ABSTRACT	18. NUMBER OF PAGES	19a. NAME OF RESPONSIBLE PERSON
a. REPORT unclassified	b. ABSTRACT unclassified	c. THIS PAGE unclassified	Same as Report (SAR)	44	

2012 concludes successfully

Signaleers,

The year 2012 concluded with some huge successes.

We had the opportunity to induct into the ranks of Distinguished Members of the Regiment, our first four-star general in the history of the Signal Corps. Details of the GEN Dennis Via, U.S. Army Material Command commanding general induction are included in this edition of the *Army Communicator*.

We also just completed a well-orchestrated General Officer and Senior Enlisted Advisor conference. As a result, I can report with great certainty that we have a clear path ahead toward meeting all of the objectives set before us.

Our Signal Regiment is a critical element in the most decisive land force in the world. I am confident that no matter what the



environment or obstacles placed before us, the Signal Corps can perform the assigned missions.

As an Army element, we share in the sacrifices of all Americans during this period of fiscal uncertainty and the constraints looming in front of us. We will continue to be good stewards of the resources we are provided by developing the capabilities the Nation needs through prudent investment and decisions in support of DOTMLPF [Doctrine, Organization, Training, Materiel, Leader Development, Personnel, and Facilities]. We are innovating, transforming and finding new and better ways to do what we have traditionally always done well.

This edition of the *Army Communicator* outlines some of the initiatives that we are moving through in the process of transforming.

As we transition to a leaner, more agile Army we must maintain the ability to operate efficiently and effectively while we are changing; essentially changing the tires while the vehicle is still running. We have to do this, because the ability to operate in the midst of change gives our national security decision makers greater flexibility in responding to national challenges at home and abroad against both conventional and hybrid threats.

The Army Profession, our standards and discipline, customs and traditions, military expertise and foundation of trust strengthen the force through periods of transition.

I am counting on each of you to continue operating as professionals and leaders. Ready and resilient is a key Army priority that we are working toward as we bring improved programs and services to Soldiers, Families, and Civilians.

I know that the Army is the strength of our Nation. Soldiers are the strength of our Army. Our Families are the strength of our Soldiers. I am always mindful of the sacrifices our Families make and I am thankful to everyone who wears the invisible uniform.

Our success requires a great deal of trust among our Soldiers, Family members and the Army. We must sustain these bonds of trust. Our enduring priority is to preserve our high-quality All Volunteer Force – Active, Guard and Reserve. We can only do this when we hold fast to the highest tenets of our values.

The country's greatest accomplishments are built on the strength of America's strongest citizens – U.S. Soldiers.

Thank you for your continued service to the people of this great nation.

Pro Patria Vigilans!

For the Country!



COMMAND

Chief of Signal
MG LaWarren V. Patterson

Regimental Chief Warrant Officer
CW5 Todd M. Boudreau

Regimental Command Sergeant Major
CSM Ronald S. Pflieger

EDITORIAL STAFF

Editor-in-Chief
Larry Edmond

Art Director/Illustrator
Billy Cheney

Photography
Billy Cheney, Marlene Thompson, Claire
Schwerin, Amy Walker, Nick Spinelli

By Order of the Secretary of the Army

Raymond T. Odierno
General, United States Army
Chief of Staff

Official:

JOYCE E. MORROW
Administrative Assistant to the
Secretary of the Army

Authorization 1232402

Army Communicator (ISSN 0362-5745) (USPS 305-470) is published quarterly by the U.S. Army Signal Center, of Excellence at Signal Towers (Building 29808), Room 713 Fort Gordon, Ga. 30905-5301. Periodicals postage paid by Department of the Army (DOD 314) at Augusta, Ga. 30901 and additional mailing offices.

POSTMASTER: Send address changes to **Army Communicator**, U.S. Army Signal Center of Excellence, Signal Towers (Building 29808), Room 713, Fort Gordon, Ga. 30905-5301.

OFFICIAL DISTRIBUTION: **Army Communicator** is available to all Signal and Signal-related units, including staff agencies and service schools. Written requests for the magazine should be submitted to Editor, **Army Communicator**, U.S. Army Signal Center of Excellence, Signal Towers (Building 29808), Room 713, Fort Gordon, Ga. 30905-5301.

This publication presents professional information, but the views expressed herein are those of the authors, not the Department of Defense or its elements. The content does not necessarily reflect the official U.S. Army position and does not change or supersede any information in other official U.S. Army publications. Use of news items constitutes neither affirmation of their accuracy nor product endorsement.

Army Communicator reserves the right to edit material.
CORRESPONDENCE: Address all correspondence to **Army Communicator**, U.S. Army Signal Center of Excellence and Fort Gordon, Signal Towers (Building 29808), Room 713, Fort Gordon, Ga. 30905-5301. Telephone DSN 780-7204 or commercial (706) 791-7204. Fax number (706) 791-3917.

Unless otherwise stated, material does not represent official policy, thinking, or endorsement by an agency of the U.S. Army. This publication contains no advertising. U.S. Government Printing Office: 1984-746-045/1429-S.

Army Communicator is not a copyrighted publication. Individual author's copyrights can be protected by special arrangement. Acceptance by **Army Communicator** conveys the right for subsequent reproduction and use of published material. Credit should be given to **Army Communicator**.

ARMY COMMUNICATOR



Worldwide web homepage address
<http://www.signal.Army.mil/ocos/AC/>
E-mail: ACeditor@conus.Army.mil

PB 11-12-04
Winter 2012
Vol. 37 No. 4

Voice of the Signal Regiment

Table of Contents

Features

- | | | | |
|----|--|----|---|
| 4 | First 4-Star Signal Corps general recognized
Willson A. Rivera | 17 | Traffic engineering solution for circuit saturation concerns
CPT Felix Torres |
| 6 |  Signal Regiment personnel structure changes | 19 | Black Core network primer
COL Garrett Yee |
| 9 |  Signal Soldiers prepared for professional certifications
Nick Spinelli | 33 | National Training Center success tips
MAJ Michael S. Ryan |
| 10 | Transforming education at the Command College
Michael H. McMurphy
Gregory Thomas | 39 | New training products and equipment information
<i>LandWarNet eUniversity</i>
LWN.ARMY.MIL |
| 12 | Human Resources Command dedicated to serving Soldiers
LTC Mark Rosenstein | | |

Special Feature--The Transition Process

Capability Set 13

- | | | | |
|----|---|----|--|
| 20 | New Army network reaches the field
Claire Heninger | 27 | Mission command technologies providing Web-based simplicity
Kathryn Bailey |
| 23 | On-the-move network backbone provides greater capabilities
Amy Walker | 29 | Capability Set 13 Q & A
COL Mark Elliott |
| 25 | Network Integration Evaluation expertise prepares units
Claire Heninger | 31 | Blue Force Tracking upgrades offer greater awareness
Nancy Jones-Bonbrest |

Cover: *This edition of the Army Communicator reveals some of the changes that are taking place in the Signal Regiment to meet changing Warfighter requirements and the processes in place to ensure the personnel training and rapidly changing systems come together simultaneously.*



Cover by Billy Cheney

Expect continuing change, transformations

Signaleers,

Having taken two years of French in high school, I was disappointed when I arrived in Belgium and could only remember the French phrase, "plus a change, plus c'est la meme chose" which basically translates "the more that things change, the more they stay the same." Oh, I could also say, "I cannot speak French" in French; but my ability to pronounce it well only caused more attempts by the French speaker on the other side of the phone to try to use French until I stated plainly, in English, "I cannot speak French!" While my ability to communicate was greatly hindered, this phrase became a sort of motto our unit lived by; "the more that things change, the more they stay the same."

Change continues to be a constant today.

In 1993 a search for the words "Blue Force" would render the 1993 computer game released by former Police Quest designed Jim Walls. A search today includes links to our Force XXI Battle Command Brigade and Below and Blue Force Tracking systems; terms that were not even in our vernacular in 1993. But we are not done yet. Leveraging the Network Integration Evaluation and Capability Set fielding efforts, CS13 equipped units will see

differences to what they may have grown used to in the past (see the article on CS13 BFT by Nancy Jones-Bobbest). And this is just one of a plethora of systems continuing to change. Even our educational principles are under transformational review (see the article by Michael McMurphy and Gregory Thomas). To transform means to change in composition or structure and it seems that every structure is under scrutiny today; what an opportunity to excel!

The Signal Regiment has always lived within this environment. Moore's Law, the observation made in 1965 by the Intel co-founder Gordon Moore, has been the accepted term used to characterize change expectation within the information technology environment. His paper noted that since the invention of the integrated circuit in 1958, the number of components populating the IC chip had doubled every year; he predicted that it would continue to do so for at least another decade.

Many have associated second and third order effects to Moore's Law that include the doubling of computing speed, the doubling of computing power, the doubling of computing volume, and the necessity for IT refresh in order to keep up. It is noteworthy to also list the inception of newer technologies and methodologies as results of the observations of Moore's Law. Everyone one of these has its own second and third order effects, challenges that we must face head on. My challenge for you today is to be a part of shaping our future; get ahead of the technology curve and help to influence the transformation of our Signaleers' capabilities. Our adversaries have proven themselves quite adept at leveraging IT to their advantage; how much more so the most Professional Army on God's green earth?

Let me conclude with another challenge, a fun challenge. This may show your age. Without using Google, can you tell me where the phrase, "plus a change, plus c'est la meme chose" comes from?

As always, thank you for your dedication and service in being ever watchful for our country.

Pro Patria Vigilans!



Todd M. Boudreau

Leaders must look toward future challenges

Signaleers,

In the complex world where we Signal Soldiers are called to operate, there are many priorities tugging on everyone who leads.

One of the most important things that a Signal Regiment leader must do is look down the road toward the future and make decisions that meet the communications needs of our Armed Forces in the complex operating environment that is evolving.

In this edition of the Army Communicator you get an overview of the changes that are in store for our Signal Regiment professional structure. The personnel transformation article by the Office Chief of Signal shares where we presently stand in the process that will help us provide the versatile Signal Soldiers that can operate effectively in many different environments that will be changing rapidly. The transformation that is underway is a process that will no doubt take more time to work out all of the details. There are many questions that are still unanswered. While we do not yet have all of the answers, you can rest assured that the end result of the current deliberations will lead to more versatile and well-trained Signal Soldiers.

One of the things that we in the Signal Corps are getting better at is communicating with one another. In November, we held the first Chief of Signal DCO forum that was designed to institutionalize a process for communicating with one another. The plan is to make this DCO forum a quarterly event so that we can keep the lines open to pass information back and forth between operators and commanders in the field and headquarters/training support personnel in the Signal Center of Excellence.

If something is being done well in the field and producing outstanding results, we want to get that activity incorporated into doctrine across the force. And if some tasks or systems are causing hurdles then we want to get those practices out of the SOP. Being able to let you know what planners and managers are doing in the schoolhouse and hearing your concerns about plans as well as current practices are making a huge difference.

Another series of articles in this edition highlight where we stand in the fielding of Capability Set 13. Through the Agile Capabilities Lifecycle Process we are fundamentally changing the acquisition system to make it faster and better aligned to Warfighter needs. The Agile Process is designed to procure and integrate systems that meet an operational need or gap that demonstrate success in Soldier-led evaluations during the Network Integration Evaluation. In essence, we are working to quickly and smoothly move new completely integrated systems to the field through a rigorous testing process.

In my travels throughout the Regiment, I am

finding that most of our units have heard and are responding positively to the clarion call to uphold our values and standards.

Ours is a profession that stands on the values of loyalty, duty, respect, selfless service, honor, integrity and personal courage. When you uphold these values, you fulfill the critical role of meeting the needs of our Nation. I encourage you to 'enforce' standards as well. Make sure that everyone who wears the uniform understands and adheres to our standards. When you walk past without correcting someone out of uniform or not adhering to our standards, you are giving license to that person. Don't do it. Standards are standards, while deployed or in a Garrison environment.

I am proud of the way you are representing our Army Profession. Keep up the good work.

Pro Patria Vigilans!



First four-star Signal Corps officer named Distinguished Member of the Signal Regiment

By Wilson A. Rivera

In the 152-year history of the Signal Corps, never has a member risen to the rank of four-star general...until now.

During a 12 Dec. 12, 2012 ceremony held at the U.S. Army Signal Corps Museum by the Chief of Signal, MG LaWarren V. Patterson, U.S. Army Signal Center of Excellence and Fort Gordon commanding general, appointed GEN Dennis L. Via as a new Distinguished Member of the Signal Regiment for his accomplishments over the course of a career.

A capacity crowd of distinguished guests and well-wishers packed the museum for the induction ceremony. The event coincided with the Signal Corps General Officer and Senior Enlisted Advisor Conference, held on post 11-13 Dec. Many of the attendees had served with or been mentored by GEN Via during their careers, and they filled the hall to see him be recognized.

Promoted 7 Aug. 2012, to his rank and current position as commanding general of the Army Materiel Command, GEN Via keeps military forces equipped with the latest technology and fields new equipment to meet the needs of warfighters on the battlefield.

"GEN Via has the responsibility to make the acquisition processes run smoothly and efficiently by analyzing costs, establishing credible benchmarks, and helping us understand where our money goes," said MG Patterson.

"In the age of shrinking fiscal resources, he has a huge task, coupled with the drawdown of troop strength and reduced funding. He has distinguished himself at every level of service," said MG Patterson during his introduction of the Regiment's 86th member.

"I can think of no better qualified individual to lead our continuing quest, to bring to the force, the resources we need today, and in the future."

GEN Via manages more than 70,000 employees



(Photo by Marlene Thompson)

GEN Dennis L. Via, U.S. Army Materiel Command commanding general accepts a certificate recognizing his appointment to the Distinguished Member of the Signal Corps Regiment on 12 Dec. 2012 in the Signal Museum at Fort Gordon.

and an annual budget of \$49 billion, while controlling \$92 billion in contracts to support more than 1 million pieces of equipment.

Only 85 Signal Corps Soldiers have been appointed to the honor since the beginning of the regimental system in 1986.

In receiving the honor, GEN Via said, "Thank you for the distinct honor of being named a Distinguished Member of the Signal Regiment," said GEN Via.

"I am deeply honored and proud to join the company of many Distinguished Members in the Regiment."

Wilson Rivera is editor of the Signal Newspaper, the Fort Gordon post newspaper.



GEN Dennis L. Via, a native of Martinsville, Va., was commissioned on 18 May 1980 in the U.S. Army Signal Corps after graduating as a Distinguished Military Graduate from Virginia State University, Petersburg, Va. He later earned a Master's Degree from Boston University, and is a graduate of the U.S. Army Command and General Staff College (class of 1991) and the U.S. Army War College (class of 1999).

GEN Via was nominated by the President of the United States for promotion to the rank of general in 2012. He was confirmed by the U.S. Senate and became the first Signal Officer to rise to the rank of general in the Regiment. He is currently assigned as the commander for U.S. Army Material Command where he served as deputy since May 2011.

Some of GEN Via's major accomplishments include command at all levels ensuring that the Soldiers being deployed were properly trained, equipped and ready to accomplish their mission and taking care of their Family members as well. He has served on the inaugural committee for the President George W. Bush first term. He always modernized his units with the latest equipment, ensuring that combat teams being deployed to Iraq and Afghanistan had equipment to track the locations of U.S. and enemy forces, jam improvised explosive devices, scan battle areas and see the enemy (for example, night vision) and other

Upon Regimental activation in 1986, the Signal Corps instituted a program for the recognition of personnel who have made a special contribution and distinguished themselves in their service to the Regiment.

The Distinguished Member selections are designed to recognize the individuals who are most notable and to promote and enhance the history of the Regiment and foster cohesion among its members.

equipment. He worked, as part of the Army's realignment and base closure; and directed and executed the relocation of Communications Electronic Command at Fort Monmouth, N.J., a 92-year-old base with over 7,000 employees (50 percent of the employees relocated) to a new facility at Aberdeen Proving Ground Base in Md.

The general's command assignments included: the 82nd Signal Battalion, 82nd Airborne Division, Fort Bragg, NC; 3rd Signal Brigade, III Armored Corps, Fort Hood, TX; 5th Signal Command, U.S. Army Europe and 7th Army, Mannheim, Germany; and the U. S. Army Communications-Electronics Life Cycle Management Command and Fort Monmouth, Fort Monmouth, NJ.

His key staff assignments included Aide-de-Camp to the Chief of Staff, Allied Forces Southern Europe, Naples, Italy; Operations Officer, J-6, Armed Forces Inaugural Committee, Washington, DC; Chief Joint Requirements Oversight Council Division, Office of the Deputy Chief of Staff, G-8, U.S.

Army, Washington, DC; and Principal Director, Global Information Grid Operations/Commander, Defense Information Systems Agency Global Operations/Deputy Commander, Joint Task Force-Global Network Operations, Defense Information Systems Agency, Arlington, Va., and Deputy Commander U.S. Army Material Command, Huntsville, Ala.

GEN Via's awards include the Defense Distinguish Service Medal; the Distinguished Service Medal with Oak Leaf Cluster; Defense Superior Service Medal; Legion of Merit with Oak Leaf Cluster; Defense Meritorious Service Medal with four Oak Leaf Clusters; Army Commendation Medal with Oak Leaf Cluster; Joint Service Achievement Medal; and the Army Achievement Medal. He is authorized to wear the Master Parachutist Badge, the Joint Staff Identification Badge, and Army Staff Identification Badge.

GEN Via is married to the former Linda A. Brown of Warsaw, Va. They have two sons, Brian and Bradley.

Signal Regiment personnel structure evolving to support changing operations

By Office Chief of Signal Staff

As our Army continues evolving to meet different requirements, U.S. Army Training and Doctrine Command leaders continue managing the changes through Doctrine Organization Training Materiel Leader Development Personnel and Facilities processes.

Any change in the way the Army does its business is managed through one or more of these "domains."

This article is about the "Personnel" domain and the Regiment's work in ensuring our Personnel structure is in full support of Army operations.

A significant driver of change in all of the DOTMLPF areas is cyberspace operations. Although

the characteristics and application of cyberspace terminology are still evolving, we do have Department of Defense definitions for cyberspace on cyberspace operations: Approved DoD Definition of Cyberspace (12 May 08) – a global domain within the information environment consisting of the interdependent network of information technology infrastructures, including the Internet, telecommunications networks, computer systems, and embedded processors and controllers.

Approved DoD Definition of Cyberspace Operations (08 Oct 08) – the employment of cyberspace capabilities where the primary purpose is to achieve military objectives or effects in or through cyberspace. Such operations include computer network operations and

activities to operate and defend the Global Information Grid.

From these, you can see that the Signal Regiment plays a key role in this new domain.

One needs only to read the newspapers and journals in reference the development of new technologies and standards or the daily attacks on our networks to understand why leaders and managers in the Signal Regiment are working a number of initiatives to build, operate, and defend cyberspace.

None of this is a new concept to the Signal Corps.

Since its formation during the Civil War, the Signal Corps has been executing these types of functions.

We needed to occupy the hills to ensure a visual line of site for communications.

We installed a wired network when sufficient time was available to provide a more robust and secure means of communication. Even then, we used codes to protect the information that was being passed over our networks.

Today, this work continues much the same in concept but, of course, radically different in technology and scope.

This article primarily focuses on the Signal Regiment's mission to defend the network; but defending the network is only one piece of our Network Operations mission.

Beginning with our Branch 25 Signal Officer, we are pushing forward with a concept that will provide additional technical education. From lieutenants to colonels, Signal officers must always be leaders first and foremost. In order to lead in this increasingly technical environment, we want

UNCLASSIFIED



Proposed Signal Regiment Holistic Officer Transformation

Legacy "As-Is" Signal Regiment AOC

- 25A – Signal Officer
- 24A – Telecommunications Systems Engineering
- 53A – Information Systems Management

Submit **DA Pam 611-21 Military Occupational Classification Structure (MOCS) Expedited Change Action** **NLT 31 May 2013**

Signal GO Guidance :

- Structure Officer AOC for Cyber
- BR25
 - More technical education and experience
 - Lead Mission Command and NETOPS integration
- FA53
 - More technical-engineering based (FA24 Like)
 - Enable knowledge management
 - Address cyber security

MOCS Action

Notional Signal Regiment AOC:

- BR25 – Signal (2LT-COL)
 - 25A – Signal Operations
 - 25G – Network Integration (New)
 - 25Z – Signal Operations (immaterial @ COL)
- FA26 – Cyberspace Systems Engineering (CPT-COL)
 - 26A – Network Systems Engineering (old 24A)
 - 26B – Information Systems Engineering (old 53A)
 - 26C – Security Systems Engineering (New)
 - 26Z – Cyberspace Engineering (immaterial @ COL)

UNCLASSIFIED

to provide a better understanding of technical capabilities that can support a myriad of missions. Today our Functional Area 24, telecommunications engineers and Functional Area 53, information systems managers perform most of the complex planning and engineering of the network within the officer cohort.

In order to ensure our Signal Officers are better postured during the military decision making process to develop technical courses of action that support the commander's operational intent, we want to create a course that provides the right knowledge, skills, and abilities required to oversee the planning, engineering, installation, operation, and defense of friendly cyberspace.

It must be emphasized that the officer concept that follows is pre-decisional and more analysis and coordination is required before going final.

In order to drive more technical training for Branch 25, a new Area of Concentration would be created, 25G, network integration officer. The intent is to ensure that all of our branch 25 officers receive this training while en route to an assignment requiring those skills.

It is an important feature of this concept that once the officer receives the training and finishes the assignment, that officer is not restricted to only 25G assignments. He/she is able to be assigned to any 25 position. This will ensure that we continue producing officers with an increased level of skill, who will then be assigned throughout the Army. These officers will continue to be eligible and competitive for Central Select List positions which include command and key billets.

Our Functional Area officer structure will undergo a significant change. We will create a new Functional Area 26 cyberspace systems engineering, within which we will have three AOCs: AOC 26A will be our network systems engineer and closely aligned with our current FA24; and AOC 26B, information systems manager and drawn from our current FA 53. What is new is the creation of FA26C, security systems engineer.

This new AOC will also have the defense of the network as a primary focus. Our analysis shows that the career path for an officer desiring to be a 26C will incorporate skills acquired through assignments to both 26A and 26B positions. This ability to assign these officers still within the FA26 but also between

UNCLASSIFIED



Signal Warrant Officer Transformation (Implemented 1 Oct 12)

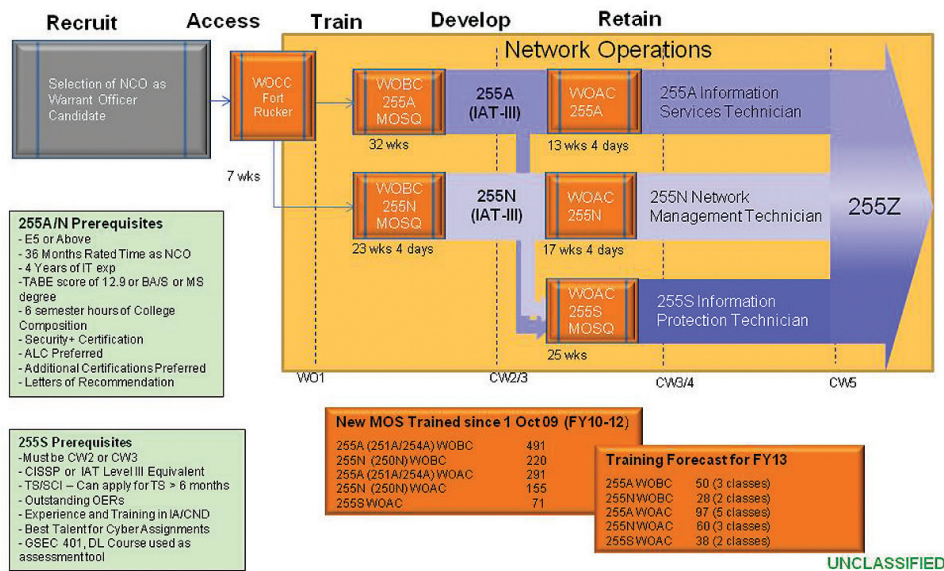

UNCLASSIFIED

AOC 26A and B as required is a key feature to this realignment.

Planners within the SIGCoE recently completed what we called a Subject Matter Expert Panel which looked at the requirements and skill sets for these technically trained and educated leaders. It is important to note that the Chief of Signal MG LaWarren V. Patterson in his opening remarks to the Board challenged them to look as far into the future as their crystal ball would allow. The dynamic nature of information technology and the very challenges that new technology introduces require us to be proactive and agile so that we can ensure we are posturing our officers and the Army for success.

The transformation of our warrant officers is virtually complete. Effective 1 October 2012, a new warrant officer Military Occupational Specialty structure appeared in Army authorization documents. This transformation aligned a warrant officer with each component of NetOps: enterprise systems management (network management), content management (information services), and network assurance (cyber security). This personnel alignment maps precisely with the documented organizational structure for the corps/division G-6s and BCT/multifunctional brigade S-6s. Two of our warrant officer MOSs (255A and 255N) are refinements of the older version of our warrant officer structure in that the 255A's pri-

(Continued on page 8)



Revise BR 25 and Establish New Graduate Level Systems Engineering FA26

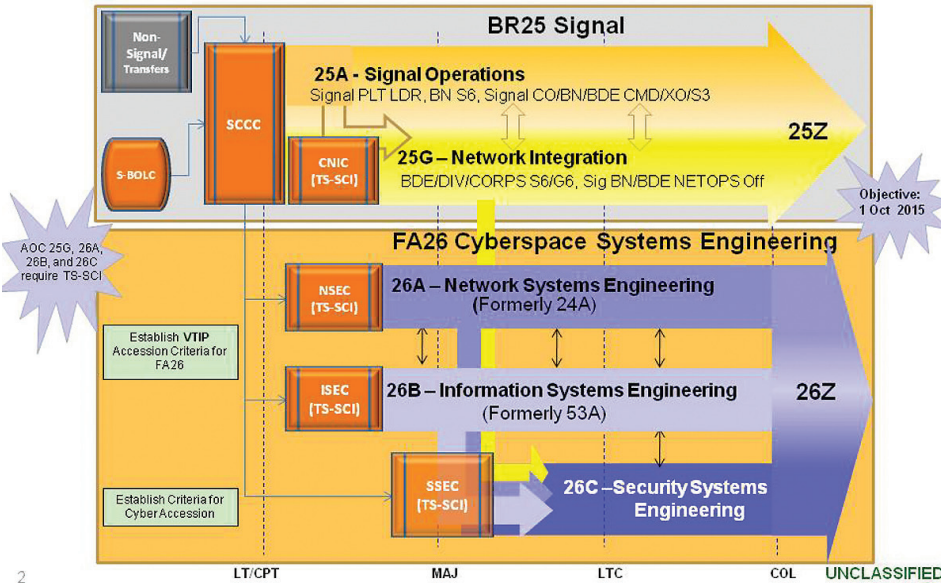

(Continued from page 7)

mary function is the information systems and the 255N's primary function is the network.

What is new is the 255S information protection warrant officer whose major focus is the defense of the network.

In our analysis, we determined that this area was becoming increasingly complex and capitalized on the skills and experiences that the 255A and the 255N were accruing so the 255S will be accessed at the CW3 grade from our other two warrant officer MOSs. This ensures that we have seasoned warrant officers focused on the defensive cyberspace operations mission. Assignments for this warrant officer will be down to the BCT level and all higher echelons to include national agency level.

Finally, our enlisted cohort will also undergo changes. An action has been submitted to TRADOC that will create the MOS 25D cyber network defender MOS. This enlisted Soldier will provide that backbone of support beginning at the BCT through to the highest echelons within the Army and joint level, DoD, and national agencies. Today, our MOS 25B, Information Technology Specialist, execute

some of these functions. The 25B, however, executes a broad range of requirements to include Systems Administrator, Network Administrator, Help desk, and more. The requirement is to have a Soldier who is dedicated to the mission of defending the network.

The creation of this MOS establishes a 'cradle to grave' career path that ensures a Soldier receives the right training and repetitive network defense assignments so the experience level of that Soldier grows with the ever changing mission. There will be five duty positions for the 25D: computer network defense infrastructure support, CND analyst, incident responder; CND auditor, and CND manager (E8/E9 level).

Similar to the accessions model discussed for the officers and warrant officers, this MOS will be an inter-service accession at staff sergeant from other specialties and based on proven performance and demonstrated level of skill. There will also be additional accession criteria for qualification. The Office Chief of Signal will be establishing a screening test to ensure the Soldiers accessed will be able to execute the complex demands of this MOS. Soldiers will also hold a current certification under either IAT Level II or IAM Level I IAW DoD 8570.01-M.

Although it is expected the vast majority of accession will come from our MOS 25B population, other Soldiers who have met the requirements in skill, leadership, duty performance and who are able to acquire a Top Secret clearance will be eligible.

If you are interested in these new professional opportunities, you need to seek out assignments that execute cyber security functions and acquire selected certifications. But as the officer AOCs and the enlisted MOSs do not exist yet, a call to HRC will not be productive. However additional information on the 25D MOS is available at the website: <https://www.us.army.mil/suite/page/838>

This process will take a few years and there will be a distribution of additional information as it is available.

Join the Discussion
<https://signalink.army.mil>



ACRONYM QuickScan

AOC - Area of Concentration
CND - Computer Network Defense
CSL - Central Select List
DoD - Department of Defense
DOTMLPF - Doctrine, Organization, Training, Materiel, Leader Development, Personnel, and Facilities
GIG - Global Information Grid
IT - Information technology
MOS - Military Occupational Speciality
NetOps - Network Operations
TRADOC - U.S. Army Training and Doctrine Command

Signal Soldiers prepared for certification, licensing opportunities

By Nick Spinelli

An Army-wide initiative is encouraging Soldiers to earn civilian credentials, certifications, and licenses for their military specialties and training. Currently there are 58 Army occupations that have operational credentialing programs and students at the U.S. Signal Center of Excellence have the opportunity to earn various information technology certifications and licenses.

"The U.S. Army Signal Center of Excellence conducts world-class training and education in Signal telecommunications, cyber defense, network operations, and related fields," said COL Bruce Caulkins, SIGCoE G6, in an information paper written 20 Sept. 2012. "And the schoolhouse works diligently to assist Soldiers, warrant officers and officers to help them achieve commercial IT [information technology] certifications on a case-by-case basis."

For example, the SIGCoE offers training in Cisco and Microsoft programs, and the information technology specialist curriculum includes courses that prepare advanced individual training students to take exams for CompTia credentials in fields such as network security.

"We prepare people who will need these certifications," said David Kintner, deputy director of training on Fort Gordon. "We provide Soldiers with everything they need to know in order to take and pass certification and licensing exams in their fields."

In order to accomplish this, the Signal school runs Prometric and Pearson Vue testing centers, enabling students to take and pass any IT exam more conveniently. "Most Signal students are well positioned to take and pass commercial information technology certification tests during their training time with little or no extra training required on their part," he said. While credentialing is encouraged, it is not a requirement for students.

"Currently, no Signal MOS course mandates any student to earn IT certifications - outside of the Information Assurance realm - during training," COL Caulkins said. "However, increasing commercial off the shelf-based training and education requirements at the SIGCoE will continue to allow students to pursue these certifications easily due to the nature of the education they receive during their classes."

Additionally, certain positions require those in them to have certifications.

"There are some jobs where, whether Soldier or civilian, the person holding the position is required to be certified," Kintner said. "And while we prepare people for certification, it's important to note we do not certify them."

Soldiers in Information Assurance Workforce positions are required to achieve the appropriate level of certification within six months of assignment. In order to help them accomplish this, vouchers and requisite maintenance fee tokens are purchased by the Army every year. COL Caulkins says in fiscal 2013, the Army expects to purchase 5,800 Computing Technology Industry Association vouchers; 3,500 CompTIA annual maintenance fee tokens; 500 International Information Systems Security Certification Consortium ((ISC)2) CISSP vouchers; 280 ISC2 CISSP annual maintenance fee tokens; 180 Information Systems Audit and Control Association Certified Information Security Manager vouchers; 420 ISACA CISM annual maintenance fee tokens; and, 20 SANS annual maintenance renewals.

According to COL Caulkins, approximately 4,746 students will attend Signal courses and be eligible to take various commercial IT certifications. Costs for these exams vary:

- Network+ is \$253
- Cisco Certified Network Associate is \$295
- Cisco Certified Network Professional routing, switching, and troubleshooting are \$200 each
- Project Management Professional is \$600
- A+ is \$356 for two tests
- Windows 2008 Server is \$300 for two tests
- Network Appliance is \$200
- VMware is \$150
- SANS Global Information Assurance Security Essentials Certification is \$450
- Security+ is \$253
- Certified Information Systems Security Professional is \$600
- SANS GIAC Security Leadership Certification is \$450.

Soldiers in different career fields and with different skill levels will take different tests based on the individual MOS requirements, and the Army will assist as much as needed. For instance, Kint-

(Continued on page 10)

TRANSFORMING EDUCATION AT THE COMMAND AND GENERAL STAFF COLLEGE

By Michael H. McMurphy
and
Gregory Thomas

The Signal Regiment continues to make substantial curriculum contributions at the Command and General Staff College in Fort Leavenworth, Kan. Since 2007, coordination with and through the college's Department of Army Tactics provides important educational opportunities to our Iron Majors. But before describing the transformation, a short examination of what the Regiment is currently doing is necessary.

Beginning in 2009, the then Chief of Signal received approval from the deputy commandant of the college to conduct Signal specific education for U.S. Army Signal officers. The course was an end-of-year elective at CGSC

The Signal Center of Excellence and the Command and General Staff College team up to give Signal Iron Majors a demanding, relevant and changing course that includes three significant Military Decision Making Process opportunities.

consisting of 12, two-hour class sessions. The U.S. Army Signal Center of Excellence, through the 442d Signal Battalion, led the elective. CGSC's Department of Army Tactics was serving as a supporting effort for coordination with the college. Iron Majors would enroll in the class and be presented with eight of the

twelve meetings consisting of guest speakers from throughout the Signal Regiment. The significance of the elective is that the SIGCofE leaders select and CAC provides funding for the speakers to travel from their duty location to Fort Leavenworth and present Signal-specific instruction and mentoring. In this manner, the SIGCofE is able to harvest CGSC elective hours for the Regiment's institutional education by providing their own instructors, Signal specific curriculum, and funding. The Signal elective is a premier educational opportunity that no other branch can duplicate. No other elective in CGSC can match the weight of the educational value presented by senior Signal leaders such as a current corps G6, the senior Signal observer-controller from the Joint Readiness Center, the commander of the 106th Signal Brigade and a subordinate network enterprise center director, and so on. The success of the elective is evident by the resoundingly positive feedback from the Iron Majors.

Signal Soldiers prepared for certifications

(Continued from page 9)

ner described a new 25-week training course for warrant officers in the information security field. "The course is taught by the premiere information security experts in the world," he said. "Their instructors come here and train our warrant officers, who can then apply for the voucher program in order to take the tests." To learn more about job certification and credentialing for a specific Army MOS and get a leg up on the competition, check out Credentialing Opportunities On-Line, the Army's COOL website at www.cool-dev.com/army/search.htm.

Nick Spinelli is an editor/writer for the Fort Gordon post newspaper The Signal.

Join the Discussion
<https://signallink.army.mil>



Arguably the best elective offered through the Department of Tactics, the question remains “why transform the Signal elective?” The answer to that question is the lost of educational opportunities of conducting an elective at the conclusion of the year.

At the Command and General Staff College, educational outcomes include Signal officers being capable organizational leaders within the Army’s Operation Process as outlined in ADP 5.0. The current curriculum includes three iterations of the Military Decision Making Process. Signal Iron Majors are offered the opportunity, and their classmates expect them, to make significant contributions as part of a planning staff. In other words, at CGSC Signal Iron Majors execute their roles in the Military Decision Making Process three times in order to produce Paragraph 5 and Annex H of an operations order.

The relevance of the operations process and MDMP in the CGSC curriculum, compared to the signal elective being offered at the end of the school year, is obvious. The educational content of the elective needs to move from the end of the CGSC school year to the start of the CGSC school year in order to provide signal Iron Majors the opportunity to first, learn doctrinally correct branch-specific skills at the start of CGSC from the Signal Regiment, then secondly hone their professional skills during three iterations of MDMP from the Department of Army Tactics. In addition, Signal officers can also perfect their craft at planning Joint operations from CGSC’s Department of Joint/Interagency/Multinational Operations.

And that is what the Signal Regiment is doing, transforming the elective into a preparatory course at CGSC.

Beginning in January 2012, CGSC will conduct a preparatory course, Signal branch-specific, for all active duty U.S. Army Signal Officers attending at Fort Leavenworth. Its catalogue name is P943, U.S. Army Signal Officers Preparatory Course, but what it does is carry all of the important lessons from the old elective into what is quickly becoming a normal partnership between CGSC and some branches.

Special Forces, the Field Artillery, and the Engineers will also reap the benefits of having their specific Iron Majors receive education from their respective branch leadership prior to conducting the curriculum of CGSC. CGSC already conducts preparatory courses for sister service and international officers. Beginning in January 2013, three

U.S. Army branches will conduct preparatory courses, led and funded through their respective center of excellence, with CGSC’s Department of Army Tactics as a partner in a supporting role.

P943 will be led by the Regiment through the 442d Signal Battalion. They will provide the funding, curriculum, and set educational end-state conditions. P943 is a five-day, 40-hour course that provides branch-specific education for the Iron Majors in order for them to possess the ability to execute their craft during CGSC in a more relevant, precise, and accurate manner. P943, like all other preparatory courses at CGSC, will be conducted prior to the start-day of CGSC and its Intermediate Level Education curriculum.

P943 is transformational. It bridges the educational gap from the Captain’s Career Course to CGSC so that Signal Iron Majors can conduct the Operations Process in either Wide Area Security or Combined Arms Maneuver core competencies. P943 provides Signal branch-specific education from the Regiment. It will facilitate a deep and broad educational opportunity for Signal officers during three MDMP sessions in CGSC.

The proof of success will not only be found in December 2013 from student after-course feedback, but through continued success of Signal Iron Majors as they significantly contribute to their gaining formations accomplishment of mission, caring for Soldiers, and growing the organization.

Michael McMurphy is a retired Signal officer whose education and assignments included Ranger School, SAMS, and battalion command. Since 2006, he has been an assistant professor of tactics in the Department of Tactics, Command and General Staff College, where he also serves as the senior signal instructor.

Gregory Thomas is a retired infantry officer who is currently an assistant professor of tactics in the Department of Tactics, Command and General Staff College.

ACRONYM QuickScan

CGSC - Command and General Staff College.
MDMP - Military Decision Making Process
SIGCofE - U.S. Army Signal Center of Excellence

Human Resources Command dedicated to serving Soldiers

By LTC Mark Rosenstein

The U.S. Army Human Resources Command provides the full spectrum human resources services to Soldiers, Veterans, Retirees and Army Families. HRC is the largest human resources organization in the world; responsible for managing Soldiers' careers from the day they enter Basic Training until retirement and beyond.

HRC was formed on 1 October 2003, by merging the personnel assets of the U.S. Total Army Personnel Command and the U. S. Army Reserve Personnel Command.

The major elements of HRC are the Enlisted Personnel Management Directorate, which provides Active and Reserve enlisted Soldiers with career guidance and support; the Officer Personnel Management Directorate, which provides Active and Reserve officers with career guidance and support; The Adjutant General Directorate, which manages Soldiers' records, promotion boards, evaluation processing, personnel actions and entitlement programs, and Veterans' support; the Personnel Information Systems Directorate, which provides Information Technology support to command functions; and various staff elements, including G3, Resource Management, Chief Information Officer, Surgeon, Inspector General, and Judge Advocate.

HRC includes more than 40 operational elements around the country under the leadership of the HRC commander. HRC is the G-1's functional proponent for military personnel management (except for the Judge Advocate General and the Chaplain branches) and personnel systems. HRC also supports the Director, Army National Guard, and the Chief, Army Reserve, in their management of the Selected Reserve. The HRC commander is also the commander of the Individual Ready Reserve, the Standby Reserve and the Retired Reserve.

In 2005, the Defense Base Closure and Realignment Commission recommended the creation of the Human Resources Center of Excellence at Fort Knox,

Ky., and directed HRC elements in Alexandria, Va.; Indianapolis, Ind.; and Saint Louis, Mo.; to move to the new facility no later than 15 Sept. 2011. The bulk of HRC activities relocated to Fort Knox over the summer of 2010; the move is now complete.

The HRC mission is to execute career management, sustainment, distribution, and transition of personnel in order to optimize Army personnel readiness, enable leader development, and strengthen an agile and versatile Army that can prevent, shape and win.

Leaders promote several critical values:

- A Team of disciplined, dedicated, passionate and inspired professionals executing the mission with compassion, care and precision.
- A team oriented on and engaged with commanders and Soldiers
- A transparent, flexible, innovative and agile command - focused on improving and transforming.
- Focus on holistic "personnel readiness" to enable the Army to prevent, shape, and win.
- Commitment to strengthening the all-volunteer Army.

HRC prides itself on its dedicated workforce, comprised of both active and reserve military and civilian members. This team of professional human resource professionals manages Soldiers supporting every mission across the force, both domestic and international.

Within EPMD is the Operations Support Division which is comprised of five Career Management Fields: 25-Signal Corps, 35-Military Intelligence, 31-Military Police, 12-Engineer and 74-Chemical. Each CMF team employs both military and civilians members to manage their population of Soldiers. Military members serve as Senior Career Advisors/Professional Development NCOs while civilian members serve as Assignment Managers. Both manage personnel in the rank of Private through Master Sergeant; coordinate Noncommissioned Officer Education System schooling; recommend and execute actions in support of enlisted structure changes, force modernization,

HRC Vision Statement

TOTAL ARMY . . . TOTAL VICTORY!



U.S. Army Human Resources Command, Fort Knox, Ky.

force development, training, recruitment, distribution, promotion, and retention; research manning and regulatory requirements; and ensure Active Component and Active Guard Reserve strength meets Army manning guidance.

Serving as a Senior Career Advisor/PD NCO is considered a career broadening assignment; high performing NCOs are encouraged to seek out these opportunities.

There are several Soldier support programs that every member of the force should be aware of. These programs were established to support our highly mobile and versatile "All Volunteer" force. The primary Soldier support programs include:

Married Army Couples Program (AR 614-200, 5-20). Provisions of this program apply to Regular Army Soldiers married to members of the RA, other U.S. military Services, or Reserve Components (RC). Soldiers married to civilians are not included. Guidance for U.S. Army Reserve AGR Soldiers married to other USAR AGR Soldiers is contained in AR 140-30, paragraph 4-2j. Married Army couples desiring joint assignment to establish a common household/Joint Domicile must request such assignment by enrolling in the Married Army Couples Program.

Application for enrollment must be submitted not later than 30 days from the date of marriage. Marriage must be valid per AR 37-104-4. Action based on intended marriage will not be considered even as an exception to policy. Only one Soldier needs to request enrollment in the MACP when both Soldiers are serviced by the same MPD/BCT/BDE S1 (signatures of both Soldiers are required); otherwise both must apply. When one MACP Soldier is considered for reassignment, the other Soldier is automatically considered for assignment to the same location or area. Assignment instructions for each member will indicate whether or not a joint assignment is approved. If one Soldier is considered for assignment, and the other Soldier does not have sufficient time remaining to Estimated Time of Separation for an assignment and does not reenlist or extend, the provisions of the MACP do not apply.

Enrollment guarantees JD assignment consideration; however, it does not guarantee that the couple

will be assigned together at the same location and/or at the same time. Consideration is continuous as long as the couple remains enrolled in the program. Favorable consideration for JD assignment will depend on: 1) A valid requisition/requirement existing in the same area for both Soldiers' military Primary Military Occupational Specialty or branch (officers) and grades and 2) Career progression of both Soldiers not being adversely affected and Soldiers being otherwise eligible for the Assignment. Married Army couples that do not enroll in the MACP indicate that JD assignments are not desired; therefore, this cannot be used as the basis to request deletion from an assignment.

Other RA married Soldiers may not enroll in the MACP but may request reassignment to join their spouses by submitting a DA Form 4187 if: 1) Married to a member of another U.S. military Service and 2) Married to a member of the RC and that spouse is ordered to Active Duty for one year or more.

Exceptional Family Member Program (AR 608-75). The Exceptional Family Member Program (EFMP) objectives are: 1) To provide certain reimbursable and nonreimbursable medically related services to children with disabilities per DODI 1342.12 with the same priority as medical care to the active duty Soldier, 2) To assess, document, and code the special education and medical needs of eligible Family members in all locations, and forward these coded needs to military personnel agencies for consideration during the assignment process, 3) To consider the medical needs of the Exceptional Family Member during the continental United States and outside the continental United States assignment process; To consider the special education needs of the EFM during the OCONUS assignment process (excludes Alaska and Hawaii); To assign Soldiers to an area where the EFM's medical and special education needs can be accommodated, provided there is a valid personnel requirement for the Soldier's grade and specialty, 4) To provide a mechanism for DA civilians to inform: a) The DODDS of the arrival of dependent children with special education and medically related service needs and b) The gaining medical activity of the

(Continued on page 14)

(Continued from page 13)

arrival of Family members with medical needs, 5) To ensure that all eligible Family members receive information and assistance needed to involve them with community support services to meet their needs, 6) To ensure facility and program accessibility to individuals with disabilities (see AR 600-7), and 7) To provide EIS to eligible infants and toddlers and their Families per 32 CFR Part 80 and DODI 1342.12.

High School Stabilization Program (AR 614-200, 5-26). Soldiers with family members in high school may request stabilization from PCS movement during the child's senior year.

The intent of the program is to provide stability to Soldiers with family members in their junior and senior years of high school. The provisions of this section apply to RA Soldiers only. Army National Guard and Army Reserve Soldiers should contact their servicing per-

sonnel office for guidance.

The RA Soldiers assigned to non-Army agencies or units must comply with all directives and regulations that apply to their command before submitting their request (for example, Soldiers assigned to the Defense Courier Service must comply with DODD 5200.33-R).

Requests should be submitted no earlier than March of the student's sophomore year, and not later than the commencement of the student's junior school year (for example, Student's projected graduation date is Jun 2013; submit request between March - September 2011). Requests submitted outside of this time frame will be considered as an exception to policy and must be justified as to the delay of submission. Soldiers may be eligible to PCS before the start of the student's junior year of high school.

All requests will be submitted to the HRC for consideration. The HRC (Director, EPMD) is the approval/disapproval authority.

Soldiers will request stabilization using a DA Form 4187 or memorandum.

The request will be forwarded to the CG, HRC (AHRC-EPO-P) and will include the following: 1) A letter and/or memorandum from the high school with the student's name, SSN, and projected graduation date (included as an attachment to the request), 2) A statement on the Soldier's request: "Student (child's full name) is enrolled in DEERS."

All students must be enrolled in Defense Enrollment Eligibility System and must be under the direct care and/or custody of the Soldier submitting the request, 3) A copy of the DD Form 1172 (Application for Uniformed Services Identification Card DEERS Enrollment) will be attached to the Soldier's request, if the student's last name is different from the Soldier's, and 4) Outside continental United States Soldiers whose Date Estimated Return for Overseas is prior to requested stabilization date must include the following statement in their request: "I will extend my foreign Service tour to meet the stabilization requirement. Based on my new DEROS, I understand that I must still meet the required time remaining in Service requirement to be eligible for reassignment to CONUS."

Soldiers enrolled in the MACP must both apply, if both desire stabilization under these provisions. Requests for stabilization of CSM/SGM and/or selectees for the USASMC will be coordinated with the HRC, CSM/SGM Branch (AHRC-EPS). For Soldiers on AI, normal reassignment rules apply. That is, Soldier may request deletion or deferment in accordance with AR 600-8-11. These requests will be considered as an exception to policy. Stabilization under these provisions may be changed or canceled due to the changing needs of the Army.

Compassionate Reassignment



Lerissa Wilson (25U), Dale Ketron (25C/L) and Terry Conner (25B) discuss nominative and training-based assignments such as Defense Information Systems Agency and Drill Sergeant assignments.

Program (AR 614-200, 5-14). Compassionate actions are requests from individual Soldiers when personal problems exist. The two types of compassionate requests are when personal problems are: 1) Temporary (resolvable within a year) and 2) Not expected to be resolved within a year. Soldiers may be reassigned, deleted or deferred from AIs, or attached as a result of an approved compassionate request.

Soldiers requesting reassignment may be assigned to an area other than their requested geographical preference based on availability of medical services and the needs of the Army. Soldiers may request reassignment from: 1) CONUS to CONUS, 2) OCONUS to CONUS, 3) CONUS to OCONUS, or 4) Within same OCONUS command.

Normally, the following conditions alone are not a basis for a compassionate request: 1) Soldier's desire is to be in a new area, 2) Divorce or separation that is the result of Family separation due to military requirements, 3) Legal actions and court appearances for matters relating to divorce and/or child custody issues, 4) Recent awarding of custody of dependent child or children to the Soldier under the terms of a divorce or legal separation by temporary or permanent court order, 5) Sole parenthood, 6) Pregnancies involving threatened miscarriage, breech birth, cesarean section, or Rhesus factor incompatibility of spouse, 7) The problem expected to be resolved by Family members joining the Soldier at their duty station, 8) Minor allergies suffered by the members of the Family due to climatic conditions, 9) Problems relating to home ownership or housing shortages, 10) Financial problems alone or as the result of mismanagement of financial affairs by the Soldier or the Soldier's Family or problems related to an off-duty job, spouse's job, or private business activities, or 11) Chronic

problems relating to parents or parents-in-law.

Soldiers are not authorized to submit more than one request for reconsideration for the same or similar extreme Family problem. Commanders who are General Courts Martial Convening Authority will review each application to determine that the established criterion has been met. Requests that do not meet standards for a change in assignment will not be approved by the general court-martial authority. Applications that are not approved will be returned to Soldiers. Reasons for disapproval will be specified. Guidance for requesting compassionate actions for USAR AGR Soldiers is contained in AR 140-30, paragraph 4-2k.

Home Base and Advance Assignment Program (AR 614-200, 9-1). The practice of returning Soldiers to their previous Permanent Duty Station (PDS) or a different location after completing a dependent restricted short tour is referred to as the Home Base/Advance Assignment Program. The two types of assignments in the HAAP are: 1) Home base assignment. Soldiers are projected to return to the installation where they were stationed prior to completing a dependent-restricted 12-month OCONUS short tour and 2) Advance assignment. Soldiers are projected to return to a different installation than they were stationed prior to completing a dependent-restricted 12-month OCONUS short tour. Participation in the HAAP is optional. However, the Soldier's desire not to participate in the HAAP will be indicated in his or her PCS orders. Active Army Soldiers, CPL (P)/SPC (P) (and those CPL/SPC on a second or subsequent enlistment) through MSG (except MSG (P)), are eligible to participate in the HAAP when they are issued an assignment instruction to a dependent-restricted 12-month OCONUS short tour area. Primary determining factors for the HAAP are: 1) The needs of

the Army, 2) Assignment preference or volunteer location of the Soldier, 3) Professional development considerations, and 4) Least cost factors. Hawaii and Alaska residents may be provided a home base or advance assignment to their respective states. All others will not be given a home base or advance assignment in Hawaii or Alaska without their consent. Eligible Soldiers stationed in an OCONUS accompanied long tour who volunteer for an intertheater transfer will be notified in advance of their projected home base or advance assignment. The intent of both the HAAP is to reduce Permanent Change of Station costs and to increase stability for the Soldier and his or her family. Soldiers who receive a home base assignment under the HAAP must sign a statement indicating that they understand the intent of the program and that they are expected not to use their dependent PCS entitlements unless the assignment is cancelled. Soldiers who receive a HAAP advance assignment to a different installation will sign a statement indicating that they understand the intent of the program and are expected not to use their dependent travel and transportation allowances except to the locale of the advance assignment. Soldiers with Special Qualification Identifier "P" (parachutist) are provided a home base or advance assignment to installations authorized parachutists, unless the installation is overstrength parachutists. The home base or advanced assignment may be changed or canceled due to changing needs of the Army (authorizations), or because the Soldier: (1) Declines to participate, (2) Voluntarily extends his or her foreign service tour for any length of time, (3) Is selected to attend the SGM course, or (4) Is selected for promotion to SGM while serving on a dependent-restricted

(Continued on page 16)

(Continued from page 15)

12-month short tour. Soldiers who participated in the HAAP may also request a change of home base or advance assignment. Each request will be considered on a case-by-case basis.

If either the Soldier's current home base or advance assignment is canceled or changed based on the needs of the Army, then the Soldier may use dependent PCS entitlements and allowances not yet executed for movement to next assignment.

Similarly, if the Soldier, executes his or her dependent PCS entitlements and allowances contrary to provisions contained in paragraph 9-2e, above, then the Army may cancel or change the previously approved home base or advance assignment.

These programs are designed to help our "All Volunteer" force. When used appropriately, they will improve the quality of life for Soldiers and their families and help our Army better man-



age the assignment process. As a side note -- Soldiers should be familiar with the Assignment Satisfaction Key available on the Army Knowledge Online portal under "My Personnel."

The ASK Soldier Assignment Module allows Soldiers to

indicate assignment preferences and even request specific assignments. Soldiers should also be familiar with the HRC portal <http://www.hrc.army.mil> in order to better manage their Army career.

LTC Mark Rosenstein joined the U.S. Army Signal Corps after serving as a field artillery officer. Over his career he has held a variety of leadership and staff assignments including: battalion commander, corps and division G-6 plans officer, brigade and group S-3, battalion executive officer and company commander among others. He deployed to Iraq twice with V Corps and the 22nd Signal Brigade for Operation Iraqi Freedom and later with the NATO Training Mission - Iraq as an Advisor/Mentor. He also deployed to Haiti with the 10th Signal Battalion, 10th Mountain Division for Operation Uphold Democracy. He is currently serving as chief, Enlisted Signal Branch, Human Resources Command.

ACRONYM QuickScan

AC - Active Component
AD - Active Duty
AGR - Active Guard Reserve
AKO - Army Knowledge Online
AR-PERSCOM - United States Army Reserve Personnel Command
ASK - Assignment Satisfaction Key
BCT - Brigade Combat Teams
BRAC - Defense Base Closure and Realignment Commission
CMF - Career Management Field
CONUS - Continental United States
DEERS - Defense Enrollment Eligibility System
DEROS - Date Estimated Return from Overseas
EFM - Exceptional Family Member
EFMP - Exceptional Family Member Program
EPMD - Enlisted Personnel Management Directorate
ETS - Estimated Time of Separation
GCMCA - General Courts Martial Convening Authority
HAAP - Home Base/Advance Assignment Program
HRC - U.S. Army Human Resources Command
IMA - Individual Mobilization Augmentation
IRR - Individual Ready Reserve

JD - Joint Domicile
MACP - Married Army Couples Program
NCOES - Noncommissioned Officer Education System
OCONUS - Outside the Continental United States
OPMD - Officer Personnel Management Directorate
OSD - Operations Support Division
PCS - Permanent Change of Station
PD - Professional Development
PDS - Permanent Duty Station
PERSCOM - U.S. Total Army Personnel Command
PERSINSD - Personnel Information Systems Directorate
PMOS - Primary Military Occupational Specialty
RA - Regular Army
RC - Reserve Component
SQI - Special Qualification Identifier
TAGD - The Adjutant General Directorate
USAR - U.S. Army Reserve
WIN-T - Warfighter Information Network-Tactical

How traffic engineering can solve the problem of circuit saturation

By CPT Felix Torres

The dynamics of U.S. military communications in the Afghanistan Theater has changed dramatically over the last few years.

There have been significant upgrades in bandwidth from the typical 8 Mbps satellite circuits to 10 Gbps fiber optic metropolitan area network solutions. The capability to support increased customer requirements and efficiency provided by Internet Protocol based transport were the initial drivers to facilitate a migration from legacy Time Division Multiplexers (e.g. Promina) to the IP based infrastructure found in the Afghanistan Black Core Network today.

An additional advantage of leveraging IP transport is the ability to dynamically provision bandwidth to all traffic traversing the network as their bandwidth requirements fluctuate.

The Black Core Network was introduced into production in early 2010 and modeled after the Defense Information System Agency backbone infrastructure. The BCN in Afghanistan continues to grow and mature as the primary method of transporting secure communications. The introduc-

tion of Multiprotocol Label Switching to the BCN allowed for each customer's traffic to be isolated into its own virtual circuit. Separation of customer traffic is made possible by maintaining a separate routing table on the BCN for each virtual circuit. Improvements in hardware and routing protocols have enabled multiple concurrent means of transport on the battlefield that previously were limited to large strategic entities such as DISA.

In certain parts of Afghanistan, mission critical traffic has to compete for bandwidth on congested links. In the aggregate, throughput requirements exceeded allocated bandwidth.

Even though there are other paths available on the BCN, standard routing techniques required all traffic, including Secure Internet Protocol Routing, Non-Secure Internet Protocol Routing, and coalition partner networks to transit through a single primary path. As the BCN transport system grew to include additional customers outside of NIPR, SIPR & CX-I, the need to prioritize traffic based upon operational impact began to emerge.

Despite the fact that Black Core routing allowed for the dynamic provisioning of bandwidth for SIPR/NIPR/CX-I based on need, this may not be enough as traffic separation becomes a priority as well.

To overcome the limitations imposed by standard IP routing techniques, network engineers in Afghanistan began employing Multi Protocol Label Switching "Traffic Engineering."

Traffic Engineering allows for the routing of data across multiple transmission media concurrently. Where previously, standard routing protocol may only allow the

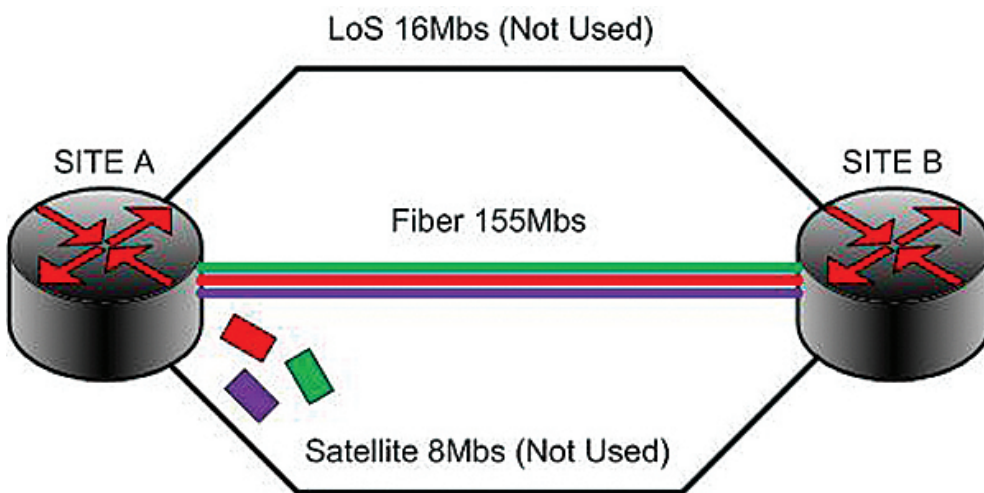

Requirement: 160Mbs
Available Throughput: 155Mbs
Deficit: 5Mbs

(Continued on page 18)

(Continued from page 17)

transmission of data over a single fiber path, Traffic Engineering can enable the transmission of data across fiber and satellite links at the same time. For example, by using Traffic Engineering, if it became necessary, network engineers can provision mission critical SIPR/CX-I over low-latency fiber paths between sites, while directing non-critical NIPR over high-latency satellite links.

The BCN uses many different modes of transmission including fiber optic, commercial and military Line of Sight radios and different bands of satellite terminals. Figure 1 shows how normal routing would occur for NIPR, SIPR and CX-I traffic.

MPLS-TE enables the use of all links between a Forward Operating Base or Combat Outpost and its hub. For example, MPLS-TE makes it possible to concurrently use a 155Mbps fiber path, an 8Mbps satellite link and a 16Mbps Line of Sight shot between Site A to the regional hub at Site B. This is accomplished by routing traffic for one enclave (e.g. SIPR) over a commercial LoS link, traffic for another enclave (e.g. CX-I) over a fiber optic link and traffic for another enclave (e.g. NIPR) over a commercial satellite link, as illustrated in Figure 2.

This results in a substantial return on investment by allowing operational forces to take advantage of multiple links and providing failover in outage situations. It also allows mission critical

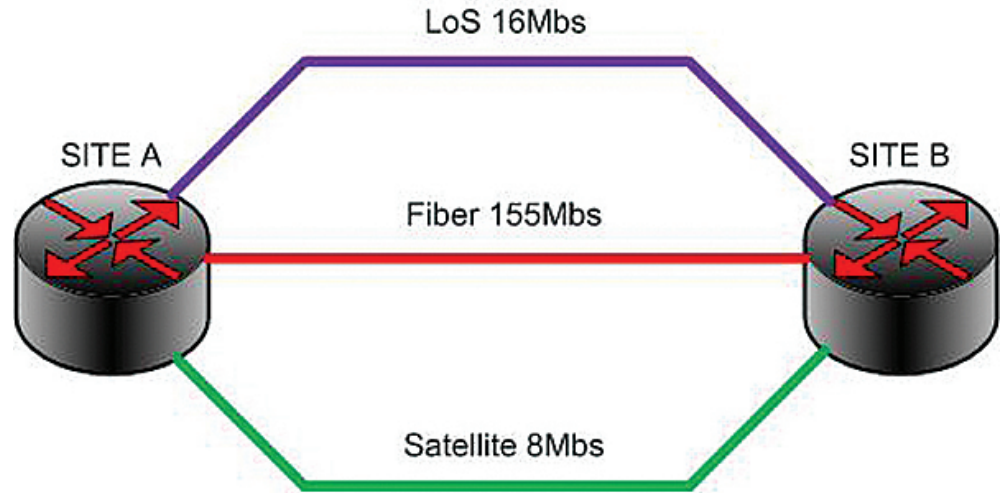

Requirement: 160Mbps
Available Throughput: 179Mbps
Deficit: 0

traffic to be routed over higher speed links, as in the example above.

The Afghan BCN continues to evolve in its development and now exists at over 70 sites within the Combined Joint Operation Area -Afghanistan. An argument could be made that the ingenuity of the BCN engineering team in leveraging technology such as MPLS-TE has saved the Department of Defense countless dollars in recurring monthly service provider charges and capital equipment expenditures while exemplifying the intelligent application of technology to solve problems on the battle field.

CPT (P) Felix Torres is the Principal Network Engineer / Task Force 236 - Afghanistan Officer in Charge for the 335TH Signal Command (Theater) (Provisional) stationed in Kabul, Afghanistan.

ACRONYM QuickScan

BCN - Black Core Network
CENTRIXS-ISAF, CX-I - Combined Enterprise Regional Information Exchange System - International Security Assistance Force
COP - Combat Outpost

DISA - Defense Information System Agency
FOB - Forward Operating Base
Gbps - Gig bits per second
IP - Internet Protocol
LoS - Line of Sight
Mbps - Mega bits per second

MPLS - Multiprotocol Label Switching
MPLS-TE - Multi Protocol Label Switching Traffic Engineering
NIPR - Non-Secure Internet Protocol Routing
SIPR - Secure Internet Protocol Routing

A Black Core network primer

By COL Garrett Yee

In military communications, encrypted information is commonly called “black data.”

The term “Black Core Network” refers to a physically segregated network that is only responsible for the transport of encrypted data using Internet Protocol infrastructure.

Commercial vendors have used this method to transport data for several years; however, the Armed Services communicators, who act as Network Service Providers, have only recently taken advantage of the BCN in order to deliver Defense Information System Network services to customers throughout the Combined Joint Operations Area – Afghanistan.

In Afghanistan, we have had significant growth in transmission capability within the last few years, going from a standard 8 Mbps satellite circuit up to a 10 Gbps fiber optic ring supporting the Greater Kabul Metropolitan Area.

The requirement to support increased throughput and IP based transport served as initial drivers to facilitate migration from legacy circuit-based Promina systems to the IP based infrastructure found in the Afghanistan BCN.

An additional advantage of leveraging IP transport is the ability to dynamically provision band-

width as customer requirements fluctuate, as well as the ability to mix traffic of arbitrary classification. That is, once classified traffic is appropriately encrypted, it can be transported across BCN. For example in the past, if a site had been provisioned for 4 Mbps for Secure Internet Protocol Routing and 4 Mbps for Non-secure Internet Protocol Routing, a change to the amount of bandwidth allowable for SIPR and NIPR required re-provisioning the circuits on the Promina.

An IP based infrastructure allows traffic from any network, such as SIPR or NIPR, to use all of the bandwidth available while the black core router will give priority to traffic based on rule sets rather than re-provisioning circuits on the Promina.

For example, up to 100% or 8 Mbps of the available bandwidth could be used for either SIPR or NIPR, as required, as well as prioritize traffic.

While the concept of having a BCN remains straightforward, we have seen significant improvements since 2010 when the Army first introduced BCN into production in the Kabul area of Afghanistan in support of U. S. Forces Afghanistan.

As the BCN transport system grew to include additional customers outside of SIPR or NIPR, such as supporting our coalition partner network, the requirement

to isolate each customer’s traffic began to emerge.

The introduction of Multi Protocol Label Switching to the BCN allowed for each customer’s traffic to be isolated into its own virtual circuit, known as Virtual Route Forwarding, on the BCN routers which allowed for logical separation of traffic based on classification level.

MPLS also allows optimization of bandwidth by leveraging a technology known as traffic engineering. Traffic engineering allows a site to utilize multiple parallel circuits concurrently rather than them just acting as primary/alternate redundancy, a topic that warrants its own separate discussion.

The Afghan BCN continues to evolve in its development and now exists at over 70 sites in support of USFOR-A with similar models emerging throughout Southwest Asia.

Over the past few years, we have seen a herculean effort undertaken to make BCN utilizing MPLS a standard in CJOA-A. In short, the BCN has become a game changer for the communications community in supporting the war fighter in Afghanistan.

COL Garrett Yee is the deputy commander – Afghanistan for the 335th Signal Command (Theater) (Provisional), stationed in Kabul, Afghanistan.

ACRONYM QuickScan

BCN – Black Core Network

CJOA-A - Combined Joint Operations Area – Afghanistan

FOB - Forward Operating Base

Gbps – Gigabits per second

IP – Internet Protocol

Mbps – Megabits per second

MPLS - Multiprotocol Label Switching

NIPR - Non-Secure Internet Protocol Routing

SIPR - Secure Internet Protocol Routing

USFOR-A - United States Forces Afghanistan

VRF - Virtual Route Forwarding

New Army network reaches the field

By Claire Heining

After two years of Soldier-driven doctrinal development, evaluation and integration, the Army is delivering its new tactical communications network to select Brigade Combat Teams, introducing both critical technology upgrades and a deliberate approach to how units are equipped with the network.

Soldiers from the 10th Mountain Division's 3rd BCT at Fort Drum, N.Y., and 4th BCT at Fort Polk, La., were the first to receive Capability Set 13, which began fielding in October 2012. The 4th BCT, 4th Infantry Division at Fort Carson, Colo., will be

the next to get the new gear starting early in 2013.

Through mobile communications technology that connects all echelons of a brigade combat team down to the dismounted Soldier, the Capability Set 13 network will reduce units' reliance on fixed infrastructure, extend the range of communications and improve battlefield awareness at the lowest levels.





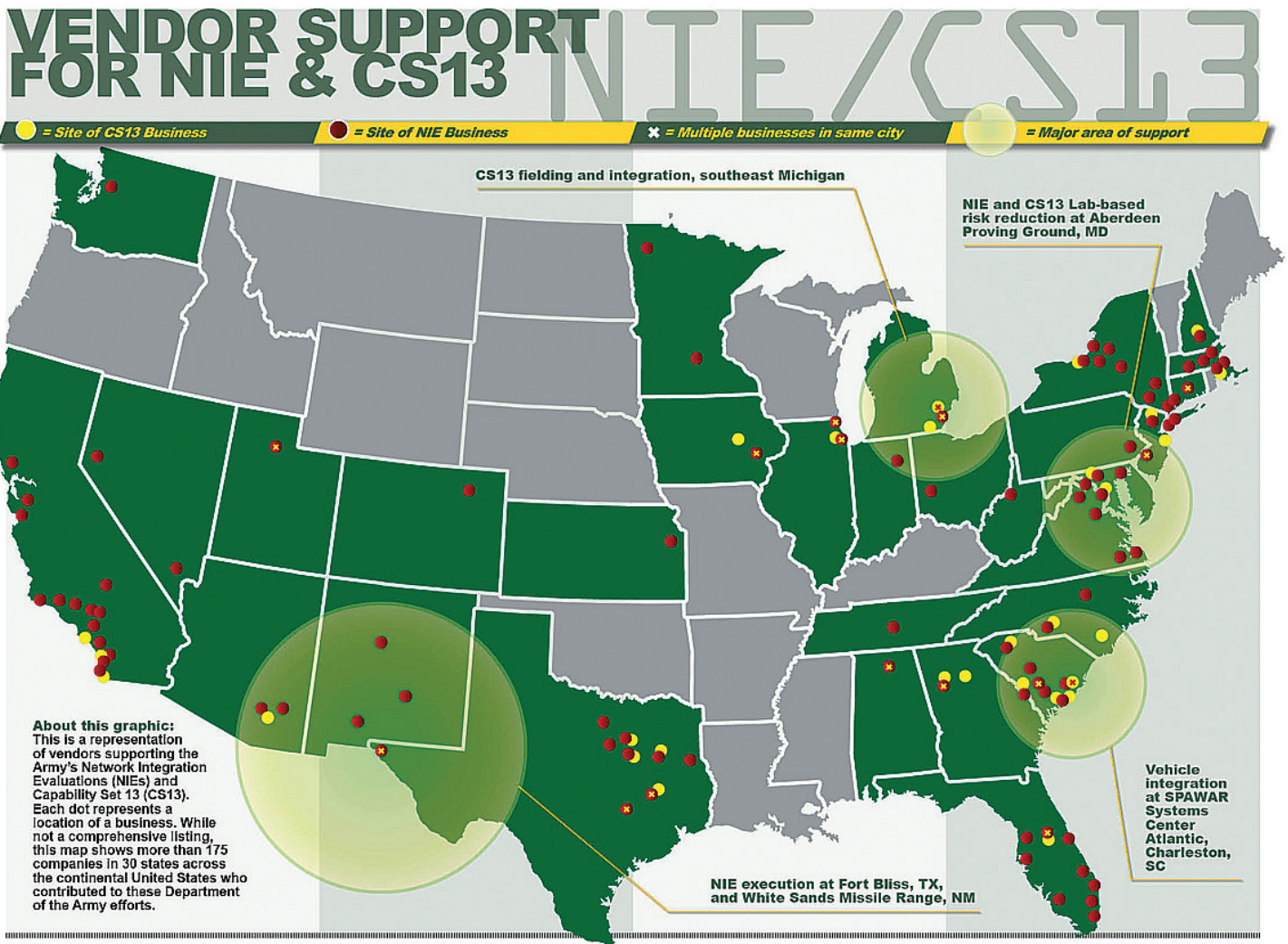

"This capability will allow us to remain mobile and will not tie us to fixed facilities," said COL Walter E. Piatt, deputy commanding general for support of the 10th Mountain Division.

"This capability changes the equation, and gives us situational awareness where we need to



COMMANDERS REQUIREMENT BY ECHELON

* MISSION COMMAND ESSENTIAL CAPABILITIES WHITE PAPER
19 JUNE 2010

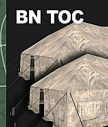
	SOLDIER	TM LDR	SQD LDR	PLT LDR / SGT	CO CDR	CO TOC	BN CDR	BN TOC
<p>"THE NETWORK IS AN ENABLER FOR JUST ABOUT EVERYTHING YOU'RE DOING." COL. JOHN MORRISON, DIRECTOR OF THE ARMY G-3/5/7 LANDBARNET-BATTLE COMMAND DIRECTORATE</p> <p>MCEC REQUIREMENTS*</p>								
	Voice, PLI (one way, up)	Voice, PLI, SA	Voice, PLI, SA, C2	Voice, PLI, SA, C2, maps & control graphics, orders, SITREPs	Voice, PLI, SA, C2, maps & graphics, orders, SITREPs, sensor data, video	Voice, PLI, C2, SA, maps & graphics, orders, SITREPs, whiteboard, sensor data, video	Voice, PLI, C2, SA, maps & graphics, orders, SITREPs, sensor data, video	Voice, PLI, SA, maps & graphics, orders, SITREPs, whiteboard, sensor data, video
CONNECT TO	Soldier, TL	Soldier, TL, SL, PL	Soldier, TL, SL, PL	Soldier, TL, SL, Co Cdr	Plt Ldrs, Co TOC, Bn Cdr/TOC, Fires, Log Spt, JIM	Plt Ldrs, Co Cdr, Bn Cdr/TOC, Fires, Log Spt, JIM	Co Cdrs/TOCs, Bn TOC, Bde Cdr/TOC, Fires, Log Spt, JIM	Co Cdrs/TOCs, Bde Cdr/TOC, Fires, Log Spt, JIM
NETWORK REQUIREMENTS	FM voice and GPS (15 kbps/2 mbps)	FM voice, GPS, data (15 kbps/2 mbps)	FM voice, GPS, data (15 kbps/2 mbps)	FM voice, GPS, data (15 kbps/2 mbps)	Internal/external C2 voice, SIPR, video, sensor links (1.2 mbps/2-4 mbps)	Internal/external C2 voice, SIPR, NIPR, VoIP, video, sensor links (1.2 mbps/2-4 mbps)	Internal/external C2 voice, SIPR, video, sensor links (>4 mbps)	Internal/external C2 voice, SIPR, NIPR, VoIP, video, sensor links (>4 mbps)
NETWORK EQUIPMENT	Rifeman Radio	Nett Warrior	Nett Warrior	Nett Warrior, HMS MP, MBITRS	WIN-T: SNE/Mobile PoP; JTRS: MNVR, HMS MP; Nett Warrior, JCR/ JBC-P BFT2	MC Systems; JTRS: MNVR, HMS MP; Req: ATH WIN-T PoP/COTS	WIN-T: Mobile PoP, MC Systems, Nett Warrior; JTRS: MNVR, HMS MP, JCR/JBC-P BFT2	WIN-T: Inc 2 /SMART-T/ GBS/Trojan Spirit/CSS USA7/MC/PAG-NET/ TRC-190 (v)/JCR/ SINGARS; JBC-P/SC TACSAT/HF Radio/JTRS

have it and turn it against the enemy."

As U.S. forces continue to draw down in Afghanistan, they will turn over many of their Forward Operating Bases and other infrastructure to the local forces, thus gradually losing fixed network locations. Capability Set 13 systems provide mobile satellite and robust radio capability for commanders and Soldiers to take the network with them in vehicles and while dismounted as they conduct security assistance and some combat missions. Leaders say that ability would prove critical when the brigades are called on to deploy.

"As I look at upcoming missions, our ability and my ability to communicate with those Soldiers on the ground over extended distances - that's really what will give us the edge as we go forward," said COL Sam Whitehurst, commander of the 3rd BCT, 10th Mountain Division.

Capability Set 13 is the Army's first fully-integrated package of radios, satellite systems, software applications, Smart-phone-like devices and other

network components that spans the entire brigade combat team formation, connecting the static tactical operations center to the commander on-the-move to the dismounted Soldier. It directly addresses 11 critical operational needs statements submitted by combatant commanders and offers U.S. forces vastly increased capabilities to communicate and share information.

"When you look at the communications architecture that now is able to rapidly process not just voice communications, but data communications from the brigade to the battalion down to the company level, it increases your ability to conduct mission command in a complex environment with changing situations more effectively," said COL Thomas Dorame, commander of the 2nd BCT, 1st Armored Division (2/1 AD), the brigade that validated CS 13 prior to fielding. "If you have Soldiers in contact or you have a developing situation, you have better situational awareness (with) which to make decisions, and as you make those decisions faster and clearer

to the lowest level."

CS 13 not only introduces new technologies, but also represents a new approach to how the Army equips units with the network. For the first time, the Army is fielding network systems not on an individual basis, but as an integrated communications package for the BCT. That requires a new, highly synchronized approach to production and deliveries of CS 13 equipment. New equipment fielding and training for different systems have been synchronized with one another and with the units' other pre-deployment requirements and exercises.

"We're bringing all of the individual systems together, synchronizing them, and fielding them together as a capability package to give to the unit," said COL Rob Carpenter, Army director of System of Systems Integration. "Up front, we make sure this equipment is usable, trainable, and sustainable so we don't put gear out there we don't need, and we don't leave the integration to the commanders and

(Continued on page 22)

(Continued from page 21)

Soldiers in the field.”

Before delivery to CS 13 units, the capability set was validated through the Network Integration Evaluations, a series of semi-annual events that leverage 2/1 AD conducting rigorous mission scenarios in a realistic operational environment at Fort Bliss, Texas, and White Sands Missile Range, N.M.

“The NIE is a tough environment – we see integration problems that we haven’t seen before,” said MG Genaro Dellarocco, commander of the Army Test and Evaluation Command, which along with SoSI and the Brigade Modernization Command forms a “Triad” of organizations that execute the NIEs. “The beauty of this is we’re shaking off these systems stateside, not on the battlefield.”

NIEs have not only allowed for Soldier-driven evaluations and assessments of network technologies, they have also aided the Army in development of Tactics, Techniques and Procedures for using Capability Set 13. Lessons learned from the NIEs have been applied as the Army works to field, train and sustain the Capability Set, and feedback from the 10th Mountain Division and 4th Infantry Division will also help the process evolve for future brigades.

By using the NIEs to establish an integrated network baseline and to inform training, techniques and procedures, the Army can also rapidly incorporate new technology and adapt it based on different mission requirements.

“We’re able to give (receiving brigades) some insights about what worked and what didn’t through trial and error,” said LTC Andy Morgado, G3 with BMC. “The goal is to get better every time. So CS 13 is going to the Army with clear strengths, because we made the decision that we’re

better fighting with it than without it, but there are still certain limitations to the systems that we’re going to refine and improve upon, which will be CS 14 and forward.”

CS 13 is on track to field to select Infantry Brigade Combat Teams (with priority to units deploying or preparing to deploy to Operation Enduring Freedom and a forward stationed brigade in Korea) from 2012-2013. CS 14, the next iteration, is targeted for fielding to Stryker BCTs beginning in 2014.

In the meantime, as the first CS 13 units rotate out of OEF, other units will fall in on that equipment in theater, including the mine resistant ambush protected vehicles equipped with mobile communications technologies. The Army is also installing CS 13 systems onto High Mobility Multipurpose Wheeled Vehicle platforms that will be used as training sets by continental U.S. units as they prepare to deploy.

Leaders say the NIE and Capability Set construct will continue to evolve, but will form the foundation for how the Army delivers the tactical communications network in the future.

“This is an enduring process,” said COL Mark Elliott, director of the Army G-3/5/7 Landwarnet-Mission Command Directorate. “It allows us to look at requirements coming out of theater from a doctrinal perspective, all the way down to the training and operational perspective, to how the unit is going to integrate it. That will be our iterative process that we’ll go through.”

Claire Heining is a staff writer for Symbolic Systems, Inc. supporting the U.S. Army Program Executive Office Command, Control and Communications-Tactical. She is a graduate of the University of Notre Dame and a former Statehouse reporter for *The Star-Ledger*, New Jersey’s largest newspaper.

ACRONYM QuickScan

10th Mountain - 10th Mountain Division
2/1 AD - 2nd Brigade, 1st Armored Division
ATEC - Army Test and Evaluation Command
BCT - Brigade Combat Team
BMC - Brigade Modernization

Command
CONUS - Continental United States
CS - Capability Set
HMMWV - High Mobility Multipurpose Wheeled Vehicle
MRAP - Mine Resistant Ambush Protected Vehicle

NIE - Network Integration Evaluation
OEF - Operation Enduring Freedom
SoSI - System of Systems Integration Directorate
TTPs - Tactics, Techniques and Procedures

Capability Set 13

New on-the-move network backbone

By Amy Walker

The continued fielding of Warfighter Information Network-Tactical Increment 2, the backbone of the Army's new network capability set, enables commanders to take advantage of the improved situational awareness provided by a mobile adhoc network that reaches down to the company level for the first time.

"As I think about how we fought in 2005 and being able to look to 2012, it is tremendously forward in terms of how we can communicate with every Soldier," said COL Sam Whitehurst, commander of the 3rd Brigade Combat Team, 10th Mountain Division, one of two units currently being fielded with these advanced technologies.

"[In the past] I had to go through fixed locations to talk to other units on the battlefield. Now I can be on the move as a brigade commander and I can talk to every single company in my area."

Capability Set 13 is the first fully-integrated package of radios, satellite systems, software applications, Smartphone-like devices and other network components that provide connectivity from the stationary command post to the commander on-the-move to the dismounted Soldier.

WIN-T Increment 2 is the tactical communications network backbone that binds the capability set together.

"A major advantage in fielding disparate systems as an integrated package, as the Army is doing with CS 13, is that it provides a synchronized and integrated set of new capabilities to the units at one time, so the commanders will be able to take full advantage of the network," said COL Ed Swanson,



(U.S. Army photo by Amy Walker)

A Soldier from the 2nd Brigade, 1st Armored Division climbs into a Warfighter Information Network-Tactical Increment 2 Point of Presence vehicle during the Army's Network Integration Evaluation 13.1 at Fort Bliss, Texas in November 2012.

project manager for WIN-T. "These capabilities provide comprehensive, real-time information, faster than ever before across the full range of military operations."

The Army received the go-ahead to continue with limited production and fielding of WIN-T Increment 2 as a result of a Defense Acquisition Board review conducted in late September. The Army remains on schedule in its fielding timeline for WIN-T Increment 2 as part of CS 13, which began in October with two BCTs from the 10th Mountain Division, and will continue with follow-on CS 14 development to add additional capability to the force.

At the same time that it fields to CS 13 units, the Army will continue to work with the Office of the Secretary of Defense and the test community to aggressively address items identified during the Initial Operational Test &

Evaluation for WIN-T Increment 2, which was held in May as part of the Army's Network Integration Evaluation 12.2.

Going forward the Army will leverage NIE events for future WIN-T Increment 2 testing focused on specific areas to continuously improve the system. WIN-T Increment 1, formerly known as the "Joint Network Node - Network," began fielding in 2004 and provides Soldiers with high-speed, high-capacity voice, data and video communications down to battalion level units, at-the-quick-halt.

WIN-T Increment 2 provides Soldiers with a single, integrated and on-the-move network down to the company level. It further increases capability by introducing self-forming, self-healing network-

(Continued on page 24)

(Continued from page 23)

ing radios and enhancing Network Operations.

"WIN-T Increment 2 enhances capability below the battalion level; we push high-capacity communications all the way down to the company level, so for the first time ever a company now has access into those Global Information Grid services on the SIPR side, much like those provided to higher echelons," said LTC Robert Collins, product manager for WIN-T Increment 2.

As part of the first CS 13 fieldings, 10 weeks of WIN-T Increment 2 New Equipment Training for 10th Mountain's 4th BCT at Fort Polk, La., and 3rd BCT at Fort Drum, N.Y., began in early October, with the WIN-T Increment 2 NET teams scheduled to train roughly 230 Soldiers. During the WIN-T Increment 2 NET, Soldiers are introduced to and trained on the actual WIN-T Increment 2 communications equipment they would be operating in theater, if and when they are called to deploy.

The training provides the Soldiers with the knowledge necessary to not only install, operate and maintain the WIN-T Increment 2 equipment in combat, but also the skill to manage the complex network.

Managing the many facets of the network is often a daunting task for a communications officer, but WIN-T Increment 2's suite of integrated monitoring tools makes the job easier. These NetOps tools give the S6 the capability to successfully support the mission requirements and the commander's intent on an improved common operating picture.

"We've made revolutionary progress with WIN-T Increment 2's NetOps," LTC Collins said.

"Much like operational commanders command and control their combat forces, they can now

plan and manage the network, implement information assurance protective postures, all from a remote location."

The WIN-T Increment 2 NET finishes with a crew drill training exercise that provides Soldiers with the practical experience of working as a team using realistic operational scenarios to bring up the Increment 2 network. As a part of the crew drills, Soldiers must conduct at-the-halt and on-the-move missions validating their understanding of the NET concepts and techniques.

"The Soldiers taking part in the NET are enthusiastic and the leadership is very supportive to make sure that this is a first-class training exercise for those units," LTC Collins said. "WIN-T Increment 2 serves as a cornerstone for the success of the capability set fielding series, so this training exercise is very critical."

Following training completion the equipment will be configured for operational use, new equipment fielding will be completed and then the unit will begin a series of events designed to prepare them for potential deployment. While it is early in the fielding and training process, 10th Mountain Division leaders said they can see

the operational value of the increased mobility and situational awareness delivered by WIN-T Increment 2 and CS 13.

For example, a commander on-the-move will now be able to quickly receive and act on information about an enemy's whereabouts, said COL Walter E. Piatt, deputy commanding general for support of 10th Mountain Division.

"Before messages would come down from a battalion [executive officer] to another fixed facility and by the time it would get passed to me I may have already hit an ambush," said Piatt. "Now that intelligence can be shared quicker. Now we know where we are, where reported enemy sightings are, so we can take the initiative and attack the attackers that were waiting in ambush for us. It's getting the information when you need it."

Amy Walker is a staff writer for Symbolic Systems, Inc. supporting the Army's Program Executive Office Command, Control and Communications-Tactical (PEO C3T); Project Manager Warfighter Information Network-Tactical (WIN-T) and MilTech Solutions. She graduated from The College of New Jersey, Ewing, N.J.

ACRONYM QuickScan

10th Mountain - 10th Mountain Division

BCT - Brigade Combat Team

CS - Capability Set

DAB - Defense Acquisition Board

IOT&E - Initial Operational Test and Evaluation

NetOps - Network Operations

NIE - Network Integration Evaluation

OEF - Operation Enduring Freedom

OIF - Operation Iraqi Freedom

PEO C3T - Program Executive Office for Command, Control and Communications - Tactical

SIPR - Secure Internet Protocol Router

WIN-T - Warfighter Information Network-Tactical

WSMR - White Sands Missile Range

NIE expertise prepares units

By Claire Heininger

WO1 Mark Miller has his hands full serving as the net tech for one of the first Brigade Combat Teams to be fielded with Capability Set 13.

Fortunately, he also had a preview.

WO1 Miller, net tech for the 3rd Brigade, 10th Mountain Division, spent a month at Fort Bliss, Texas during preparations for the Network Integration Evaluation 13.1, shadowing his counterparts in the 2nd Brigade, 1st Armored Division in order to learn various network technologies and management tools. When new equipment fielding and training began in October 2012 at Fort Drum, N.Y., he was better prepared for the challenge.

"Just the fact of getting my hands on the equipment was invaluable," WO1 Miller said. "The exposure to it was great."

WO1 Miller's experience is part of a larger effort to link 2/1 AD with 3/10 MTN and other units receiving Capability Set 13. By sharing both the technical expertise and operational lessons-learned that 2/1 AD has gleaned through four NIEs, the Army aims to better prepare other units to operate with the new network.

"We all want to make sure we deliver a quality product to the Army," said LTC Andy Morgado, G3 for the Brigade Modernization Command, which is charged with compiling Soldier feedback out of the NIE and making recommendations to Army leadership. "There's no better way of confirming that from the Soldier's perspective than getting with the guys who are actually going to field it in harm's way, and making sure they are comfortable with what they're getting."

(Continued on page 26)



(U.S. Army photo by Claire Heininger)

Soldiers from the 2nd Brigade, 1st Armored Division work inside the Tactical Command Post during the Army's Network Integration Evaluation 13.1 in October 2012. The Army is sharing the technical expertise, operational lessons-learned and training best practices 2/1 AD has gained through the NIEs with the units receiving Capability Set 13.

(Continued from page 25)

That exchange is taking place in multiple ways, including weekly conference calls between NIE subject matter experts and the receiving brigades, video interviews with 2/1 AD leadership on how to leverage the network for various operations, and inviting signal officers to gain hands-on experience setting up and operating CS 13 during the run-up to NIE.

"It gave them the opportunity to not only help us get the network up and running, but also understand some of the intricacies," said MAJ Ernest Tornabell, S6 for 2/1 AD. "That way they can set themselves up for success – so when the systems do come there, they can already have a plan of action and be able to execute that plan of action to address the fielding and training of their Soldiers. With the amount of information they gain here, they will at least be able to be that much further along than if they were just given the equipment and told, 'Hey, here you go.'"

CS 13 units also formally receive information on each system's strengths and limitations, as well as Soldier-developed tactics, techniques and procedures for operating the equipment. Training best practices for CS 13 systems – individually and as an integrated set – were also developed through the NIE. The training is designed not just to make Soldiers proficient on the systems within their individual specialties, but also to understand how those systems fit in with the rest of the brigade network structure.

That is a change from the last decade of war, when the Army provided network capabilities in response to urgent needs, but did not always have the infrastructure and processes in place to support them, leaving Soldiers to figure out how they worked and how they integrated with the rest of their equipment. The NIE is designed to perform the integration and establish proper training up front. Many of the training personnel involved in the NIEs, who are now familiar with how to build training for a collective package of systems, are now training units on CS 13.

For 2/1 AD Soldiers, the direct connection to CS 13 units adds a sense of urgency to their mission at NIE. SGT Lance Bradford, 2/1 AD, said he has de-



(U.S. Army photo by Claire Heininger)

Soldiers from 2nd Brigade, 1st Armored Division drive a vehicle equipped with Warfighter Information Network-Tactical (WIN-T) Increment 2 during the Army's Network Integration Evaluation (NIE) 13.1 in November 2012. WIN-T Increment 2 is a major upgrade to the tactical network backbone that enables mobile mission command.

ployed three times and sees the value of the NIE in evaluating network gear on behalf of other Soldiers.

"We understand their needs," SGT Bradford said. "It definitely does give you a sense of worth to put stuff out downrange."

Others have an even closer connection. As they rotate out of 2/1 AD, some Signal Soldiers are being assigned to CS 13 units, while others are dispatched to those units on a short term basis to assist them in training and building their network infrastructure.

"They have a lot of experience with it, they need to go to units that are fielding the system," LTC Morgado said. "They've learned an awful lot by being here."

Claire Heininger is a staff writer for Symbolic Systems, Inc. supporting the U.S. Army Program Executive Office Command, Control and Communications-Tactical. She is a graduate of the University of Notre Dame and a former Statehouse reporter for The Star-Ledger, New Jersey's largest newspaper.

ACRONYM QuickScan

10th Mountain - 10th Mountain Division
2/1 AD - 2nd Brigade, 1st Armored Division

BCT - Brigade Combat Team
BMC - Brigade Modernization Command
CS - Capability Set

NIE - Network Integration Evaluation
TTPs - Tactics, Techniques and Procedures

Mission command technologies providing Web-based simplicity

By Kathryn Bailey

When the Army instituted the Mission Command doctrine in 2011, it did so to hold the commander and Soldier accountable for achieving mission goals through a shared understanding of the operational environment.

This philosophical shift is empowering leadership from the edge. It requires technological solutions incorporating all warfighting functions of maneuver, fires, sustainment, airspace management and air defense.

With Capability Set 13, the Army is converging existing software capabilities and introducing enhanced, web-based capabilities that create the synergy necessary for the commander's decision making abilities and mission execution.

"The mission command capabilities that are part of CS 13 provide a simplified, unified package to help commanders and their staff collaborate for success," said COL Jonas Vogelhut, project manager for Mission Command.

One of the biggest challenges facing the commander in today's command post is the requirement to mentally fuse multiple data sources displayed on separate viewers to achieve a unified battle space picture. To ease this burden, PM MC began converging logistics, fires, air defense and airspace product lines in 2010 by creating an enhanced version of Command Post of the Future, the situational awareness system that processes and displays combat information onto digital maps from other Army systems.

PM MC continues to enhance

CPOF with CS 13 through improved 3-D map capabilities, upgraded automatic process flow and disconnected operations.

To continue its goal to provide enhanced yet, simplified mission command collaboration capabilities, PM MC developed a rich web client solution called Command Post Web.

CP Web converges all warfighting function capabilities to allow users access to applications, or widgets, over the Internet instead of through software installed on a computer. CP Web uses the National Security Agency's Ozone widget

framework, a government-owned product, also used by Defense Information Systems Agency for joint service requirements, that allows the Army and third-party developers to develop and field widgets specific to the mission through a web-based marketplace. Similar to the "App Store" on an iPhone, developers can create applications, based on a pre-defined set of rules. Following successful beta launches in Afghanistan and Germany, CP Web and several widgets are part of CS 13.

(Continued on page 28)



(U.S. Army photo by Claire Heninger)

A Soldier from the 3rd Brigade Combat Team, 10th Mountain Division uses Capability Set 13 equipment at Fort Drum, N.Y., in October 2012. Through mobile communications technology that connects all echelons of a BCT down to the dismounted Soldier, the Army's new CS 13 network will reduce units' reliance on fixed infrastructure, extend the range of communications and improve battlefield awareness at the lowest levels.



(U.S. Army photo by Claire Heninger)

A Soldier from the 2nd Brigade, 1st Armored Division uses Nett Warrior during the Army's Network Integration Evaluation 13.1 in October 2012. Nett Warrior leverages commercial smartphone technology to provide an integrated dismounted leader situational awareness system for use during combat operations.

(Continued from page 27)

"The benefit to Command Post Web is its flexibility," said LTC Thomas Bentzel, the Army's product manager for Tactical Mission Command, assigned to PM MC. "You can go to the website, pull up your widget or widgets, and see your data on a map, chart or table. It provides a window into the Common Operating Picture to Soldiers who don't have CPOF."

The new and/or enhanced operational widgets scheduled for release in CS 13 include the Maneuver Widget, which receives and integrates data from all other Mission Command systems that contribute to the COP. It produces a 2-D display of the COP for the commander and staff's tactical situational awareness and provides that COP data to the Map Widget for a 3-D display.

The Fires Command and Control widget allows the user to create, edit and delete geometries and plot them on the map, work with target lists and air support lists, send air support requests, send a "check fire" message to stop fire on targets, view active mission status and perform a "what If" analysis on a target.

PEO Aviation and PEO Missiles and Space are providing capabilities for the air picture through Ozone widgets. The new Sustainment/Logistics Asset Visibility widget extends Battle Command Sustainment and Support Systems capabilities via the new Log Reporting Tool, Combat Power, In-Transit Visibility, Asset Visibility and Unit Task Organization widgets.

CS 13 is also the launching point for the next technological progression towards enhancing

mission command collaboration, and it is coming by way of cloud technology. The Army has approved a set of computing technologies called the Common Operating Environment, enabling secure, interoperable and rapid application development across several defined computing environments. One of these environments is the Command Post Computing Environment, under which a partnership between PM MC and PM Defense Common Ground System - Army is converging operations and intelligence data via widgets to provide the commander with three-dimensional views for operational and intelligence awareness for ground and air reporting, field artillery commands, logistics, alerts and incident reporting.

"As we continue to develop COE, the software will provide more than an integrated Common Operational Picture for the Commander," COL Vogelhut said.

"Through bringing together multiple software systems into one environment, we gain efficiencies initially through hardware reductions, and eventually gain effectiveness through reduced training burdens and more robust information that allow Soldiers to execute enhanced mission operations."

Kathryn Bailey is the Strategic Communications Advisor for CACI-Wexford supporting Project Manager Mission Command, assigned to the U.S. Army Program Executive Office Command, Control and Communications-Tactical. She is a graduate of the University of Maryland University College and has held various communications positions supporting DoD agencies.

ACRONYM QuickScan

BCS3 - Battle Command Sustainment and Support Systems
COP - Common Operating Picture
CP CE - Command Post Computing Environment
CP Web - Command Post Web
CPOF - Command Post of the Future

DCGS-A - Defense Common Ground System - Army
DISA - Defense Information Systems Agency
NSA - National Security Agency
PM MC - PM Mission Command

What is Capability Set 13 about?

*Q&A with COL Mark Elliott
Office of the Deputy Chief of Staff, G-3/5/7
Director, LandWarNet/Mission Command*

Q: What is the intent behind fielding network systems as Capability Sets?

The concept behind capability sets is to remove the burden from the maneuver unit, the commander and the Warfighter of having to do all the integration work down at the unit level. In the past when I was down at different units, we'd get different Programs of Record, different systems that would individually show up at the unit. Although that system came as a whole, it wasn't integrated with other communications and warfighting systems across the board. The concept of the capability set is to do the integration work up front.

We use the Network Integration Evaluations to do the up-front work, which is ensuring that when we introduce some new system into our network, we take it to NIE. We make sure we've worked out the bugs, frequency challenges - we work all that out at NIE. When we take the capability set to the unit, we believe we've reduced, if not totally eliminated, all the potential challenges with integrating the systems into the unit. They get it as a complete set.

Q: Can you talk about the importance of training on network systems, and how the Army has synchronized the fielding and training for Capability Set 13 to ensure it is done right?

What we do with the New Equipment Training/New Equipment Fielding for CS 13 is take a look across all of the systems from a mission command perspective, and we integrate those things together so the unit has one training plan that is synchronized throughout.

The NET/NEF process is part of what we're learning through what we do with the 2/1 AD unit at NIE. We're not just testing and evaluating systems - we're also learning how we do the DOT-MLPF. Through the NIE, we look at the training aspect, and how do we integrate that training into units, as well as how leaders are going to utilize it,

and any doctrinal changes that may come about as a result.

Part of our goal, as we field and train network capabilities that will be used by more non-Signal Soldiers, is to make systems more intuitive - if a Soldier looks at it and says, "This is very similar to what I'm using in my everyday life."

The common user will pick up the piece of equipment and it won't be such a departure, and the learning curve is not as steep as you might think it is. That helps that young Soldier, who may not be a communications Soldier, pick up on that a lot better. We believe we've reduced the complexity down, at least as best as we can right now.

Q: How would you summarize the operational benefits provided by Capability Set 13? How will it make a difference for combat commanders?

We're pushing more capabilities down to the Soldier level. One of our chief imperatives is we want to network the Soldier. We're doing that with this Capability Set. With the Rifleman Radio and Nett Warrior, now we have position location information on each of our Soldiers. We're taking a concept that was initially used at the platform level, when we could track vehicles around with FBCB2/BFT, and now we're pushing that same concept down to the individual Soldier. For me, that is the number one major enhancement that we're excited about.

If you step up to the next level and how you're trying to do communications on the move, that's what CS 13 and WIN-T Increment 2 gives us.

Commanders are excited about that, because this mobile capability will enhance their capability to command and control beyond fixed Forward Operating Bases.

Whereas before we were a lot more reliant on terrestrial systems, now we can go with satellite communications and cover a much broader area.

CS 13 also includes new management tools that enhance the communications officer's or the warrant officer's ability to track the network at the

(Continued on page 30)

(Continued from page 29)

brigade level.

Q: What are the Army's priorities for Capability Set 14?

To continue to build on this baseline of Capability Set 13. With NIE 12.2 we established the baseline; now we're going to continue to build on that, to look at the additional capabilities we can add to that.

At NIE 13.1 we are taking a look at how we network our heavy platforms, additional ways that we power our systems, and whether we need a "mid-tier" network bridging capability to go from our lower tier to our upper tier.

We're working through that, and what type of radios to use to do that.

Q: How do you envision NIEs evolving in the future?

Just like we have worked to establish this baseline for our Army network, we are going to have to extend this to the Joint community first, and move that on to our coalition partners as well.

Given the environment, if we have to do any conflict resolution or engagements, we're probably not going to do that ourselves – we're going to do that as a joint DoD community, or bring in our coalition partners. It is a logical next step to bring those communications challenges out to NIE, then see how we can resolve them.

We're also starting to work on our aerial tier – getting smarter on how to have better communications between our air and ground platforms. We'll continue to expand the NIE, but our goal is also to make sure it's manageable for the Soldiers providing feedback.

Q: What else is important for the Signal community to understand about Capability Sets and the NIE?

If you're the average Signal reader like I was, you probably never heard of what an NIE was. A lot of people are familiar with what we used to call our Force XXI division. This is similar in nature, but we have this BCT that is available for us, a fully operational BCT that can take that

concept to the next level.

So if you haven't heard about NIE, get involved if you are interested in being on the cutting edge of what the Signal community and the broader Army is doing. Get informed, get involved, because this is the way the Army will continue to develop network capabilities in the future.

COL Mark A. Elliott was commissioned as a Signal Officer through the University of Alabama at Tuscaloosa in 1987. Some of his assignments include platoon leader and operations officer in the 8th Signal Battalion, 8th Infantry Division, Bad Kreuznach, Germany; the chief of plans and operations, Joint Communications Support Element (Airborne), MacDill AFB, Tampa, Fla. After graduating from the Army Command and General Staff College, he was assigned as the deputy G6, then G6, 1st Cavalry Division, Fort Hood, Texas, and later served as the battalion executive officer, 13th Signal Battalion, 1st Cavalry Division. After graduating from the National War College in Washington DC, COL Elliott took command of the 1st Signal Brigade, Yongsan Garrison, Seoul Korea.

ACRONYM QuickScan

2/1 AD – 2nd Brigade, 1st Armored Division
BCT – Brigade Combat Team
CS – Capability Set
DoD – Department of Defense
DOTMLPF – Doctrine, Organization, Training, Materiel, Leadership, Personnel and Facilities

FBCB2/BFT – Force XXI Battle Command Brigade and Below/Blue Force Tracking
NET/NEF – New Equipment Training/New Equipment Fielding
NIE – Network Integration Evaluation
WIN-T – Warfighter Information Network-Tactical

Blue force tracking upgrades offer greater situational awareness

By Nancy Jones-Bonbrest

On the battlefield, situational awareness not only provides a technological advantage to Soldiers, it saves lives. Now, the Army is delivering that awareness to the lowest levels.

"If you're in contact with the enemy and you're trying to figure out how to maneuver, being able to identify where your Soldiers are down to the individual is incredible," said COL Thomas Dorame, commander 2nd Brigade, 1st Armored Division. "You think about different situations that American Soldiers found themselves in - Somalia, downtown Baghdad, those complex environments - and as a squad leader, to have that situational awareness you're able to better support your Soldiers."

After more than a decade of war, the friendly force tracking system Soldiers relied on for situational awareness, Force XXI Battle Command Brigade-and-Below/Blue Force Tracking is being upgraded and enhanced through two generational steps: Joint Capabilities Release followed by Joint Battle Command-Platform. Both work with networked handheld devices to bring dismounted Soldiers into the situational awareness picture.

Prior to and as part of Capability Set 13, JCR is being fielded to Afghanistan. The system allows Soldiers in battle to view blue icons on a computer screen inside their vehicle that pinpoint the grid locations of friendly forces. They can also alert nearby friendly units of improvised explosive devices or enemy locations by plotting them in red.

The capability is comprised of computers, global positioning equipment and communication systems that work in tandem to provide near real-time information to combat leaders at the tactical level. The information it provides also mitigates fratricide. With the FBCB2 capability, Soldiers can move more freely on the battlefield knowing the whereabouts of friendly or enemy forces.

Fielded by Project Manager Joint Battle Command-Platform, the technology is being upgraded

based largely on Soldier experience and feedback. While JCR is being fielded to troops in Afghanistan through CS 13, JBC-P, which will bring enhanced on-the-move command and control capabilities down to the dismounted Soldier, is already being tested and is planned for fielding as part of CS 14.

"We're continuously improving the friendly force tracking system in order to equip our Soldiers with the most advanced tactical communications and situational awareness available," said COL Michael Thurston, project manager for JBC-P. "The upgrades will make it more intuitive for today's Soldiers and leaders."

Among the upgrades JCR brings is JCR-Logistics, which integrates FBCB2/BFT capability with Movement Tracking System for Army logisticians. The JCR-Log provides the technology necessary to communicate with and track tactical wheeled vehicles and cargo in near real time. It provides the same situational awareness, command and control messaging and fratricide avoidance found in FBCB2 today, enabling the safe and timely completion of distribution missions in support of full spectrum operations.

JCR includes access to the type one secret network through the KGV-72 encryption device, incorporates a new chat function and instant messaging capabilities, and has a powerful new map engine to allow Soldiers to render images. JCR will utilize the BFT 2 network, a new satellite infrastructure that can handle significantly more data, allowing for more frequent and larger messaging traffic.

The fieldings to Afghanistan required PM JBC-P to integrate JCR/BFT 2 onto Mine Resistant, Ambush Protected vehicles.

Several weeks prior to the JCR fielding that began in October, a group of field support representatives from PM JBC-P visited Space and Na-

(Continued on page 32)

(Continued from page 31)

val Warfare Systems Center Atlantic in Charleston, S.C., where network systems, including JCR/BFT 2, are being incorporated onto the CS 13 vehicles. The team wanted to study SPAWAR strategies for integrating JCR/BFT 2 onto MRAPs.

"We were there to learn - take some pictures, get some experience, so we could go back and train our workforce that departed for Afghanistan to be able to perform these upgrades under combat conditions," said Thane C. St. Clair, who is overseeing the upgrade for PM JBC-P. "That's a very complex vehicle, so (by gaining expertise), we can basically make a how-to guide for our installers, just like we have for other vehicles, so we can install in Afghanistan in a disciplined manner."

JCR provides a "bridge" to the subsequent JBC-P system, which will enhance the digital, on-the-move capabilities at both the vehicle and dismounted Soldier level, delivering a new level of mission command and situational awareness to small units.

The upgrade to JBC-P includes a new user interface, with intuitive features like touch-to-zoom maps and drag-and-drop icons. It also integrates the functionality of the Tactical Ground Reporting, a multimedia reporting system for troops on patrol, allowing small unit Soldiers to digitally capture, report and retrieve patrol data such as "SPOT" reports.

PM JBC-P tested its next generation capability at the recent Network Integration Evaluation 13.1.

SPC James Martagon of the 2/1 AD, who used JBC-P at the NIE 13.1, said the system's new user interface made it easier to access and use the icons, tools and applications needed to communicate.

"It categorizes everything better," he said. "There's a lot more to choose from."

To send a "SPOT" report on an Improvised Explosive Device discovery, for example, he selected an icon from the menu and dragged it to the IED's location on the map, sending a message that alerted other users to the danger.

"I grab it. I drop it. I send it," SPC Martagon said.

JBC-P will transform the way lower echelons communicate and navigate in theater by extending blue force tracking software to networked handheld devices. For the first time, dismounted leaders and those in vehicles and command posts will be able to view the precise locations of

dismounted forces.

The Nett Warrior handhelds being fielded as part of CS 13 work with JCR and JBC-P to share position location information, text messages and other key information such as nearby terrain.

LTC Roman Cantu, commander of the 1st Battalion, 35th Armor Regiment within 2/1 AD, said connecting dismounted users into the friendly force tracking system through Nett Warrior and JCR/JBC-P "signifies the next step as a military to advanced situational awareness. We now see that position location information extended to our dismounts on the ground," he said.

Nancy Jones-Bonbrest is a staff writer for Symbolic Systems, Inc. supporting the U.S. Army Program Executive Office Command, Control and Communications-Tactical. She is a graduate of the University of Maryland and a former freelance writer.

ACRONYM QuickScan

2/1 AD - 2nd Brigade, 1st Armored Division

CS - Capability Set

FBCB2/BFT - Force XXI Battle Command Brigade-and-Below/Blue Force Tracking

IED - Improvised Explosive Device

JBC-P - Joint Battle Command-Platform

JCR - Joint Capabilities Release

MRAP - Mine Resistant Ambush Protected Vehicle

MTS - Movement Tracking System

NIE - Network Integration Evaluation

PLI - position location information

PM JBC-P - Project Manager Joint Battle Command-Platform

SPAWAR - Space and Naval Warfare

TIGR - Tactical Ground Reporting

National Training Center: Success tips for Battalion Signal Officers

By MAJ Michael S. Ryan

This article provides battalion S-6s throughout the force with 10 simple tips to aid in both the execution of a National Training Center rotation or deployment into an active theater of war. These tips are based off of the observations of the Signal observer coach/trainers over the past year of rotations at the NTC. It is by no means an all inclusive checklist for success. But it does provide a quick set of tips to keep BN S-6s from running into the same frustrations of previous BN S-6s.

Those of us working at the NTC gain interesting insights into the force. We get to see the best that the Army has to offer and execute some of the most realistic and challenging training available to the brigade-sized elements. As units move through their exercise we gain an appreciation for how adaptable, flexible, and motivated our Soldiers and leaders are to accomplish the mission and get it right.

Every unit has its own unique set of challenges as they prepare for and then move through the training area. No one unit is an expert in every facet of operations. Therefore it is possible to assemble a short list of common problems that challenge almost every unit during their rotation at the NTC. These are some of the common trends and frustrations faced by many of the units.

1) Know your unit

One of the most common frustrations that S-6s have upon arriving at the National Training Center is that they do not have a clear picture of all of the communication assets within their units. It can take several painful days working long hours for the S-6 to gain a true picture of all of the assets within the unit. As the Army continues to move towards a fully digital, networked information based force, this task gets even more difficult for the S-6.

It is no longer enough to just know how many radios, antennas, computers, and printers are in the unit. The S-6 has to track the software version, MAC and IP address, LDIF role name, interoperability, compatibility, classification, anti-virus and domain status, and support chain for each asset.

This includes the systems that are not traditionally in the S-6s purview such as BCS3, MC4, and DCGS-A. The S-6 must establish and maintain a close working relationship with the unit S-4, S-2 and brigade SASMO in order to maintain situational awareness of the digital enablers.

2) Remember the lower Tactical Internet

Sometimes it is easy to forget about radios and other lower TI assets due to the emphasis placed on our upper TI architecture.

However, combat net radio and the other systems that compose the lower TI are the life-line for elements at echelon. SINCGARS, FBCB2, HCLOS, TACSAT, and other systems provide critical voice and data links to units on the move or those that do not have access to larger communication networks. Additionally, weather and other events can adversely affect the ability to maintain satellite based communication architectures. If the upper TI must come down due to high winds, or during a tactical move, mission command must be transitioned to the lower TI in accordance with the units PACE plan. Training at the NTC, and real world mission execution, doesn't stop just because the upper TI is not in system. Units must be ready to train and fight on their lower TI systems.

S-6s should be familiar with the operation and capabilities of all lower TI systems in their units. More importantly, the S-6 should have an accurate picture of how many and where these systems are throughout the unit.

Questions that the S-6 should be asking in relation to these systems include:

- Who is talking to whom on each system? What nets are supported?
- How is the unit intending to use these systems during each phase of operations?
- How do these systems interconnect? Are they interoperable?
- Can one system talk to another?
- Can a given system pass data or just voice? If it

(Continued on page 34)

COMMAND AND CONTROL STAFF ESTIMATE - CONPLAN 4567-15

<p>FORCES/SYSTEMS AVAILABLE</p> <p><u>CJFLCC</u></p> <ul style="list-style-type: none"> • V Corps, Hqs • 21 TSC • 38 HRSC • 8 EXP/SUST CMD <p><u>CJFACC</u></p> <ul style="list-style-type: none"> • 3rd Air Force <p><u>CJMC</u></p> <ul style="list-style-type: none"> • 3 CSG Task Forces • 1 ARG <p><u>US Marine Forces Europe</u></p> <ul style="list-style-type: none"> • II MEF • 2d Marine Div • 2d Marine Aircraft Wing • 2d Marine Logistics Group <p><u>CJFSOCC</u></p> <ul style="list-style-type: none"> • 10 SFG (-) • NSWTG • JSOAC <p>SUPPORTING COMMANDS AND AGENCIES:</p> <ul style="list-style-type: none"> • Department of State • Department of Justice • MAAGs & Missions • US Information Agency (USIA) • US Agency for International Development (USAID) • Defense Intelligence Agency (DIA) • Central Intelligence Agency (CIA) • National Geospatial-Intelligence Agency (NSA) • Defense Information Systems Agency (DISA) • Defense Logistics Agency (DLA) • National Security Agency (NSA) • US Information Service (USIS) • US Special Operations Command • US Transportation Command • US Pacific Command • US Strategic Command 	<p>FACTS</p> <ul style="list-style-type: none"> • USEUCOM forms JTF HQ • USAREUR forms CJFLCC • USAFE forms CJFACC • NAVEUR forms CJFMCC • SOCEUR forms CJFSOCC • CJFACC is main effort for phases I, II • CJFLCC becomes main effort for phases III, IV, V 	<p>Implied Tasks</p> <ul style="list-style-type: none"> • Determine Commander's Critical Information Requirements • Coordinate Information Assurance (IA) Procedures • Implement Electromagnetic Spectrum Management, Policy, Plans, Programs, and Direction • Provide Positive Identification of Friendly Forces Within the JOA • Establish a Collaborative Environment • Review Current Situation (Project Branches) • Formulate Crisis Assessment • Project Future Campaigns and Major Operations (Sequels) • Develop MOEs • Conduct Campaign Assessment • Develop Effects Assessment Criteria • Conduct Effects Assessment • Issue Planning Guidance • Provide Rules of Engagement • Integrate Computer Investigations and Operations in Computer Network Defense • Integrate Joint Force Staff augmentees • Establish Command Transition Criteria and Procedures • Develop transition C2 requirements for Phase IV and V if Phase V is not back to host govt • Provide Joint Force Staff Facilities and Equipment (Leverage JECs) • Coordinate Operational IO • Ascertain National or Agency Agenda • Determine National/Agency Capabilities and Limitations • Develop Multinational Intelligence/Information Sharing Structure • Coordinate Plans with Non-DoD Organizations • Establish LNO tms w/ Geo and AZ military and govt • Integrate AZ and CF military into US plans/planning • BPT conduct NEO • Identify and designate initial Boards, centers and cells reqmt 	<p>Limitations</p> <ul style="list-style-type: none"> • No cross border operations until D-Day
<p>Planning Factors</p> <ul style="list-style-type: none"> • Extended LOCs • NATO standards familiar to US UK & Turkey 	<p>Specified Tasks</p> <ul style="list-style-type: none"> • Azerbaijan will operate as part of the coalition • Azerbaijani military will have significant attrition early • Coalition forces (CF) will be well received by HN • Iran can observe SPOD/APODs • Any SPOD/APOD reception of forces will trigger Iranian escalation • United Kingdom, Turkey, Russia will contribute forces • US forces will need to provide significant portions of C4I infrastructure to and between CF partners • Iran requires 10 days from initial arrival of US forces to attack 	<p>ASSUMPTIONS</p> <ul style="list-style-type: none"> • Conduct FDOs • OO deploy forces to AO • Defend AZ territory against IR attacks • BPT conduct offensive combat operations to restore AZ border • ICW govt AZ conduct stability ops • BPT reestablish conditions for a secure and stable region • BPT transition authority to AZ defense forces or other designated authority 	<p>Critical Issues for the Commander</p> <ul style="list-style-type: none"> • CONPLAN does not include Azerbaijani nor Georgian military, need to coordinate Coalition C2 structure with host nation governments • Economic and diplomatic FDOs are reliant on other US govt agencies/dept for execution • Will Interagency deploy ACT and FACTS into theater?
			<p>Additional Capabilities Needed</p> <ul style="list-style-type: none"> • Deployable Joint Command and Control System • Joint Communications Support Element • Joint Deployable Teams • Joint Interoperability Test Command • Joint Operational C4I Assessment Team • Joint Spectrum Center • JTF Civil Support Joint Planning Augmentation Cell • JTF Global Network Ops • Multinational Information Sharing • Joint Systems Integration Center • Army Space Support Team – from 1st Space Brigade • Joint Public Affairs Support Element

Figure 1 CGSC Staff Estimate A Way

(Continued from page 33)

is passing data, does it still retain a voice capability?

- Can you leverage the system in a non-traditional way to fill a "gap" somewhere else in the communications architecture?

3) Consider Smart Books

As a generalization, communication teams that maintain and use smart books tend to have smoother rotations than teams that do not. With the breadth and depth of knowledge required by today's S-6 team, it becomes very difficult to remember all of the various configurations, settings, IP addresses, and other information required to install, operate, and maintain a units communications systems. Smart Books help to reduce confusion, configuration errors, and help to maintain unity of effort.

There are many ways to organize smart books. Some excellent examples can be found on the S-6 Community of Purpose at <https://S6.army.mil>. Teams need to customize their books to best fit their mission and responsibilities. When creating smart books, ensure that teams maintain the proper procedures and safe guards regarding the classification of the information in the book. It is a good practice to maintain separate books for the NIPR and SIPR systems. Never write down passwords in smart books. Properly mark all books and material with the appropriate classification level.

If teams must record passwords for various devices in a smart book (like TACLANes, routers, switches, and other devices that are not routinely accessed), then create a separate book just for passwords. Maintain it in an appropriate field safe, marked with the appropriate classification markings, and signed in and out on a key control roster (DA Form 5513).

4) Review Battle Drills and SOPs

Every unit should have battle drills and SOPs that cover the basics. A few examples are what to do in case of indirect fire, direct fire, convoy ambush, IED etcetera. But, how many have TOC battle drills and SOPs for the communications fight? The S-6 is responsible for generating the digital battle drills and SOPs for the unit.

Like any other battle drill or SOP, digital battle drills and SOPs must be tailored to the operational needs of each unit and reviewed and rehearsed periodically to ensure that they remain relevant. Digital battle drills and SOPs should cover such issues like:

- What actions must be taken in the event of the spillage of classified information onto a network of a lower classification?
- Actions to take in the event of a possible or confirmed compromise of a secure radio net.
- If power to the TOC is lost for an extended period of time, does the command and control element displace and if so, where? How is the battle handoff handled?

Many of the BN level battle drills and SOPs will be based in no small part on guidance from the BDE and DIV G-6. Digital battle drills and SOPs must be properly nested amongst all echelons of the communications architecture. Each battle drill and SOP must clearly identify at what level of command the decision to execute occurs. This ensures

unity of effort and command across the network.

So, the S-6s have now gained a full understanding of all of the assets within their units. They have recorded all of this information and placed it in easily understood tracking matrixes, capturing both the upper and lower TI. The S-6s then place these matrices on the portal where their teams and the brigade S-6 can access it. Copies are printed out and placed in the teams smart books (just in case the portal drops). So, now what do the S-6s do with all of this information?

5) Develop Run Estimates and COMSTAT reporting procedures within the battalion

Running estimates are critical when developing the concept of Signal support for the unit. S-6's base their initial running estimates off of their asset matrices. As assets are committed to support operations the S-6 adjusts his running estimate accordingly. Several examples of horse blankets and running estimates can be found posted on the S-6 COP.

The example on the left in figure 1 is "a way" used to teach officers at the Army's Command and General Staff College. It can be easily adapted for use at the BDE or BN level. It allows the S-6 to clearly list each of the MDMP Mission Analysis products in a consolidated format for quick reference. Using this format, and updating it as conditions change, allows the S-6 to provide the commander with timely, accurate

analysis and COAs.

An alternate approach is to use the "horse blanket" approach. Figure 2 below is an example of an S-6 horse blanket that was pulled from the S-6 COP. It uses easily understood graphical representations to keep track of unit assets. As assets are employed, or destroyed, they can be graphically indicated as such on the horse blanket. This approach focuses more on the tactical availability and capability of the assets vice the previous example, which is a more MDMP focused approach.

Either approach is a valid way to maintain a running estimate. The method

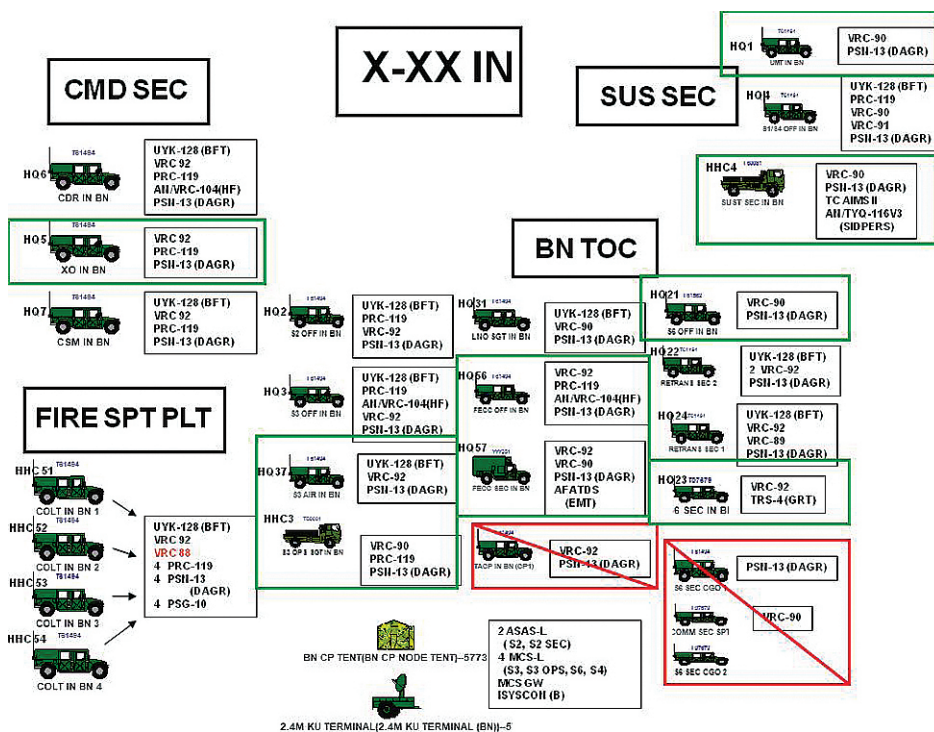

Figure 2 S-6 COP example of a COMMO Horse Blanket

(Continued on page 36)

(Continued from page 35)

used by the S-6 should be whichever is most useful for the S-6 and their commander to gain and maintain situational awareness of BN assets and plan for future operations.

Communication Status Reports are the preferred method of maintaining situational awareness of current mission command systems statuses. Again, there are a myriad of ways in which to collect and display this information within the task force; many of which can be found on the S-6 COP website. There are some important factors to consider when developing a COMSTAT:

- Displays the current status of each mission command system within the task force.
- Displays the information in a meaningful way for commanders to understand and gain situational awareness.
- Captures the reporting requirements of the next higher headquarters COMSTAT report.

Remember that the COMSTAT is the commander's tool, managed by the S-6. It must be meaningful for commanders and not bogged down in too much technical detail. Each displayed item must be relevant to the commander's decision making process. Additionally, trying to garner excessive amounts of detail from the reporting units will discourage timely reporting. The COMSTAT must balance the need for clarity and simplicity of reporting, with sufficiency in reported information to gain and maintain accurate situational awareness.

6) Plan for continuous power needs – primary and backups

Don't get caught in the dark. The only way the BN S-6 can deliver timely and accurate

communications and network systems to the unit is if there is a steady, reliable source of power. Whether it's a system running in a vehicle, on batteries, or off of a generator set, the electrons must flow from somewhere. Therefore, the S-6 must become intimately familiar with power generation in and around the TOC.

I am not advocating that the S-6 section take possession of all the power generation issues associated with the TOC. The S-3 and other sections should shoulder their share of responsibility for maintaining the generator sets. However, any generator that the S-6 sections ties into for power for their CPN or other primary communication assets should become their concern. The S-6 section needs to regularly check fuel levels, ensure proper PMCS services while in system, and make sure that all of the generator Basic Issued Items are maintained and travel with the generator. If using another section's generator, the S-6 or S-6 NCOIC needs to coordinate with the owning section to ensure that the generator is fully mission capable. Several things to consider when developing a power plan:

- Power balancing and distribution; the S-6 can aid other sections and the S-3 to ensure that the distribution plan doesn't overload one generator while not drawing enough power from another.
- Draw from multiple generation points. If your CPN is running off of generator one, make sure that your BFT TOC kit and radios are running off of generator two. That way if one fails, the TOC can still exercise mission command through the use of their PACE plan.
- Get everyone in your section properly licensed on all of the generator sets your unit utilizes. Even if your section doesn't own any of them. You never know

when you might have to tie into a different generator; knowing power generation capabilities is critical.

- Make generator maintenance a part of your daily battle rhythm within the section. Several checks per shift to ensure that the generator never falls below half a tank of fuel, the oil is at the proper level, and the generator is properly maintained. There is never a valid excuse for a generator running out of fuel.

One of the lost arts of the pre-9/11 signal section is battery management. Prior to the Army's focus on COIN and the funds that came with fighting on multiple fronts, the BN S-6 had to manage a unit's battery consumption and ordering. Complex tracking systems, budget sheets, and on-hand stocks enabled the S-6 to provide the unit with sufficient batteries to meet training objectives.

The introduction of rechargeable batteries helped to reduce the number of lithium batteries that needed to be ordered and maintained, but add a new level of complexity. Units now needed to maintain a central battery charging and recharging rotation in order to ensure that radio operators (RTOs) had sufficient batteries for each mission or training event. The S-6 needs to understand how each of the subcomponents in his unit is using batteries, what systems consume what type of battery, and how to balance the need for training with shrinking budgets. Once again, the BN S-6 will have to begin central management and tracking of batteries within the unit in order to ensure that a unit's training is not adversely impacted.

7) Think of Mission Command as a weapon system

We don't expect the company

armorers to zero and qualify our personal weapons for us. It is the individual Soldier's task to be able to zero and qualify with his rifle. The armorer is responsible for ensuring that the weapon is properly gauged, serviced, and ready for the Soldier to go to war. This is the type of understanding for mission command systems that the Army community must get commanders and fellow Soldiers to understand and embrace.

Rotation after rotation at the National Training Center, the tactical signal OC/T's observe the validation of mission command systems being passed to the S-6 and not the S-3. An S-6 ensures connectivity of systems and that data is capable of flowing between systems. S-6s should not validate the system or competence of the user. Each user needs to be able to effectively fight the battle through their mission command system. Therefore it is important that we educate our leaders on the importance of having individual users validate their mission command systems during communication and mission command validation exercises.

The S-3 must take ownership of these exercises as an operation. They must work closely with the S-6 in order to lay out a plan for validating the unit's mission command systems. It is important that this validation includes both upper and lower TI systems at echelon.

8) Relationships are key

S-6s cannot do everything alone or in isolation, nor should they try. S-6s are a member of a team, and must be willing to reach out to fellow S-6s for help, advice, and support when they need it. Conversely, S-6s must also be willing to lend aid, advice, and support to fellow S-6s

when they ask. With the complex interconnectivity of modern military communications S-6s as a community can only shine if they are all pulling together.

Therefore S-6s must make the effort to reach out to fellow S-6s and build positive working relationships and friendships within the signal community. They must also encourage their NCOs to do the same. It is this network of interpersonal relationships that S-6s will find themselves leaning on when things are going badly and they need some help to get back on track. Or, when they find that their last critical part has failed and there is a need to source a replacement faster than supply chains can supply it. S-6s may also find that fellow S-6s have some very useful refined staff products that they are willing to share in exchange for some of your products. It is relationships that make this sort of professional interchange possible, and relationships require work and time to build. If S-6s haven't already started to develop these relationships they need to begin now.

9) Bring everything

It's better to have it and not need it, than to need it and not have it.

Experience has shown that if you don't bring everything, the part you leave behind will be the one you require the most. It's the little things that tend to be forgotten, or inadequately resourced; RJ-45 tips, sufficient CAT-5 cable for multiple jumps, DVD-Rs, USB cables, ASIP retransmission cables, BFT mission data loaders, SINCGARS hand microphones, etc. It is hard to stress sufficiently to S-6s to conduct detailed inspections of unit communications equipment down to the lowest echelon, and help the companies and subordi-

nate elements to order or replace missing and broken equipment.

Sometimes due to budgets and space requirements, S-6s are forced to make hard calls on what to bring and what to leave behind when coming to NTC for a rotation. These decisions are best made when the S-6 has a solid understanding of the health and status of all of the unit's communication systems. This situational understanding is gained during the pre-rotation training events at home station. Only if the S-6 works with the S-3, companies, and subordinate elements to adequately stress, test, and use all of the organic communication systems during these training events can the S-6 evaluate where he can assume risk when packing for the NTC or deployment. If the S-6 doesn't have this level of awareness, they are assuming greater risk when choosing what to pack out and what to leave behind.

If the S-6 has to choose between critical components and systems due to space, it is up to the S-6 to discuss requirements with the XO and commander and provide a staff estimate of the risk being taken if various items are left in the rear. It is then the commander's decision to either provide the S-6 with more space or assume risk. It is not the S-6's decision to assume mission risk in a vacuum. It must be a logical and thought out decision by the chain of command, based upon the S-6's recommendation founded in facts and experience, not uniformed guess work.

10) Know the architecture

If you don't know how the BDE is communicating within itself, and its links to the larger force, you cannot make informed

(Continued on page 38)

(Continued from page 37)

recommendations to the command about future signal planning. S-6s cannot look for ways to leverage the architecture to aid your unit during mission. S-6s cannot provide their commanders with the best concept of signal support possible unless they understand their missions and communication requirements.

Where are the retransmission and relay sites for FM and what nets are they broadcasting? Is there a CPN or other upper TI node co-located with one of their elements that can be used to provide them digital services? Are there BDE level assets not currently being used that could be requested to support a mission? If S-6s don't know the BDE architecture and concept of signal support, they cannot answer these questions, or discuss intelligently about network conditions and support. S-6s must study and understand the concept of signal support.

If BN S-6s have developed a solid professional relationship with the BDE S-6, they may be able to provide suggestions on their next concept of Sig-

nal support prior to publication. Just as BN S-6s must consider subordinate elements mission and requirements, BN S-6s must ensure that the BDE S-6 understands their concept of signal support in order to source any bottom up requirements. S-6s cannot make intelligent suggestions without first understanding the architecture and mission sets within the rest of the BDE.

In conclusion these ten tips will help keep the BN S-6 from making some of the common mistakes that units tend to make when deploying to the NTC. These tips are applicable to units conducting home station training, and real world mission deployments.

MAJ Michael Ryan is currently the logistics team tactical signal observer, coach/trainer at the National Training Center, Fort Irwin, Calif. He has served as an infantry battalion S-6, ESB company commander, and deputy G-6 among various other signal staff positions. He holds a masters degree in IT management from Webster University and is an ILE and BDE S-6 course graduate.

ACRONYM QuickScan

ASIP – Advanced System Improvement Program (refers to the RT-1523 D and newer models of SINCGARS radio)
BCS3 – Battle Command Sustainment Support System
BDE - Brigade
BFT – Blue force Tracker
BII – Basic Issue Item
BN – Battalion
CAT-5 – Category 5 internet cable
CGSC – Command and General Staff Collage
COA – Course of Action
COIN – Counterinsurgency
COMSTAT – Communication Status Report
CPN – Command Post Node
DA – Department of the Army
DCGS-A – Distributed Common Ground System - Army
DIV – Division
DVD-R – Digital Video Disk - Recordable
ESB – Expeditionary Signal Battalion

FBCB2 – Force XXI Battle Command Brigade and Below
FM – Frequency Modulation
HCLOS – High Capacity Line of Site radio
IED – Improvised Explosive Device
IP – Internet Protocol
LDIF – Lightweight Directory Interchange Format
MAC Address – Media Access Control Address
MC4 – Medical Communications for Combat Casualty Care
MDMP – Military Decision Making Process
NCO – Non-Commissioned Officer
NCOIC – Non-Commissioned Officer In Charge
NIPR – Non-secure Internet Protocol Routing
NTC – National Training Center
OC/T – Observer Coach/Trainer

PACE Plan – Primary, Alternate, Contingency, Emergency Plan
PMCS – Preventive Maintenance Checks and Services
RTO – Radio Telephone Operator
S-6 COP – S-6 Community of Purpose
SASMO – Sustainment Automation Support Management Officer
SINCGARS – Single Channel Ground and Airborne Radio System
SIPR – Secure Internet Protocol Routing
SOP – Standard Operating Procedure
TACLANE – Tactical Local Area Network Encryptor
TACSAT – Tactical Satellite
TI – Tactical Internet
TOC – Tactical Operations Center
USB – Universal Serial Bus
XO – Executive Officer



LandWarNet eUniversity > Home

LWNeU Resources

- [Blackboard 7](#)
- [Blackboard 9](#)
- [FORSCOM C4 Training Wiki](#)
- [My Communities](#)

Signal Resources

- [Signal Knowledge Network](#)
- [Signal Link](#)
- [S6 Community of Purpose](#)
- [Signal Lessons Learned](#)
- [WIN-T Gateway](#)

Additional Resources

- [AKO/DKO](#)
- [Information Assurance Training](#)
- [Army Training Network](#)
- [Digital Training Management System](#)

Get Training

SEARCH FOR TRAINING

BROWSE WIKIS

UNIT UNIVERSITIES



MILGAMING
SUPPORTING GAMES FOR TRAINING
milgaming.army.mil

New BCCS Training



New on-line training available for CPOF on LWNeU

The Command Post of the Future (CPOF) Interactive Multimedia Instruction (IMI) courses provide computer-based training for both CPOF operators and system administrators.

Click HERE to start training

Training Spotlight



LWNeU Interactive Training products.

Training on:

- Mission Command Systems
- Tactical Radios
- COMSEC Devices
- Tactical Generators
- LOS Systems
- Fiber Optics

LWNeU is your resource for Information Technology, Communications Systems, Battle Command and related C4 Sustainment Training



LWNeU hosts over 15,000 pieces of training

SNAP

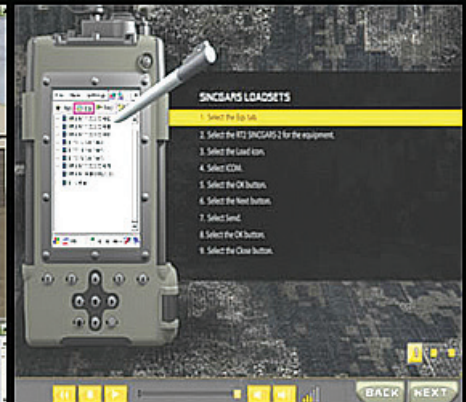
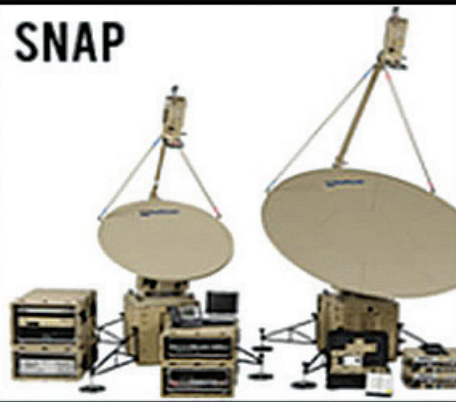



**UNITED STATES
POSTAL SERVICE®**

**Statement of Ownership, Management, and Circulation
(All Periodicals Publications Except Requester Publications)**

1. Publication Title ARMY COMMUNICATOR	2. Publication Number	3. Filing Date
	3 0 5 - 4 7 0	1 OCT 2012

4. Issue Frequency QUARTERLY	5. Number of Issues Published Annually FOUR (4)	6. Annual Subscription Price \$0
--	---	--

7. Complete Mailing Address of Known Office of Publication (Not printer) (Street, city, county, state, and ZIP+4®) U.S. ARMY SIGNAL CENTER OF EXCELLENCE, 513 CHAMBERLAIN AVE. BLDG 29808A RM 713, FT. GORDON, (RICHMOND CTY), GA 30905-5301	Contact Person LARRY EDMOND
	Telephone (Include area code) (706) 791-7204

8. Complete Mailing Address of Headquarters or General Business Office of Publisher (Not printer)
**CHIEF OF SIGNAL, U.S. ARMY SIGNAL CENTER OF EXCELLENCE, 513 CHAMBERLAIN AVE.
BLDG 29808A FT. GORDON, (RICHMOND CTY), GA 30905-5301**

9. Full Names and Complete Mailing Addresses of Publisher, Editor, and Managing Editor (Do not leave blank)
Publisher (Name and complete mailing address)

CRAIG ZIMMERMAN, OCOS DIRECTOR, U.S. ARMY SIGNAL CENTER OF EXCELLENCE, 513 CHAMBERLAIN AVE. BLDG 29808A, FT. GORDON, (RICHMOND CTY), GA 30905-5301

Editor (Name and complete mailing address)

LARRY EDMOND, U.S. ARMY SIGNAL CENTER OF EXCELLENCE, 513 CHAMBERLAIN AVE.
BLDG 29808A RM 713, FT. GORDON, (RICHMOND CTY), GA 30905-5301

Managing Editor (Name and complete mailing address)

NONE

10. Owner (Do not leave blank. If the publication is owned by a corporation, give the name and address of the corporation immediately followed by the names and addresses of all stockholders owning or holding 1 percent or more of the total amount of stock. If not owned by a corporation, give the names and addresses of the individual owners. If owned by a partnership or other unincorporated firm, give its name and address as well as those of each individual owner. If the publication is published by a nonprofit organization, give its name and address.)

Full Name	Complete Mailing Address
U.S. DEPT OF THE ARMY	105 ARMY PENTAGON, WASHINGTON, DC 20310-0105

11. Known Bondholders, Mortgagees, and Other Security Holders Owning or Holding 1 Percent or More of Total Amount of Bonds, Mortgages, or Other Securities. If none, check box None

Full Name	Complete Mailing Address

12. Tax Status (For completion by nonprofit organizations authorized to mail at nonprofit rates) (Check one)
The purpose, function, and nonprofit status of this organization and the exempt status for federal income tax purposes:

- Has Not Changed During Preceding 12 Months
- Has Changed During Preceding 12 Months (Publisher must submit explanation of change with this statement)

13. Publication Title ARMY COMMUNICATOR		14. Issue Date for Circulation Data Below FALL (September) 2012	
15. Extent and Nature of Circulation U.S. ARMED FORCES-CONUS		Average No. Copies Each Issue During Preceding 12 Months	No. Copies of Single Issue Published Nearest to Filing Date
a. Total Number of Copies (<i>Net press run</i>)		6,500	6,500
b. Paid Circulation (By Mail and Outside the Mail)	(1) Mailed Outside-County Paid Subscriptions Stated on PS Form 3541 (Include paid distribution above nominal rate, advertiser's proof copies, and exchange copies)	NONE	NONE
	(2) Mailed In-County Paid Subscriptions Stated on PS Form 3541 (<i>Include paid distribution above nominal rate, advertiser's proof copies, and exchange copies</i>)	NONE	NONE
	(3) Paid Distribution Outside the Mails Including Sales Through Dealers and Carriers, Street Vendors, Counter Sales, and Other Paid Distribution Outside USPS®	NONE	NONE
	(4) Paid Distribution by Other Classes of Mail Through the USPS (e.g. First-Class Mail®)	5,571	5,571
c. Total Paid Distribution (<i>Sum of 15b (1), (2), (3), and (4)</i>)		5,571	5,571
d. Free or Nominal Rate Distribution (By Mail and Outside the Mail)	(1) Free or Nominal Rate Outside-County Copies included on PS Form 3541	100	100
	(2) Free or Nominal Rate In-County Copies Included on PS Form 3541	50	50
	(3) Free or Nominal Rate Copies Mailed at Other Classes Through the USPS (e.g. First-Class Mail)	10	10
	(4) Free or Nominal Rate Distribution Outside the Mail (<i>Carriers or other means</i>)	300	300
e. Total Free or Nominal Rate Distribution (<i>Sum of 15d (1), (2), (3) and (4)</i>)		460	460
f. Total Distribution (<i>Sum of 15c and 15e</i>) ▶		6,031	6,031
g. Copies not Distributed (<i>See Instructions to Publishers #4 (page #3)</i>) ▶		469	469
h. Total (<i>Sum of 15f and g</i>) ▶		6,500	6,500
i. Percent Paid (<i>15c divided by 15f times 100</i>) ▶		85.7%	85.7%
16. Publication of Statement of Ownership			
<input checked="" type="checkbox"/> If the publication is a general publication, publication of this statement is required. Will be printed in the <u>WINTER 2012</u> issue of this publication.		<input type="checkbox"/> Publication not required.	
17. Signature and Title of Editor, Publisher, Business Manager, or Owner  EDMOND . LARRY . ELESTER . 1203457657 LARRY EDMOND, EDITOR-IN-CHIEF			Date 1 OCTOBER 2012
I certify that all information furnished on this form is true and complete. I understand that anyone who furnishes false or misleading information on this form or who omits material or information requested on the form may be subject to criminal sanctions (including fines and imprisonment) and/or civil sanctions (including civil penalties).			

DEPARTMENT OF THE ARMY
ARMY COMMUNICATOR
USASC&FG
ATTN: ATZH-POM
Fort Gordon, Georgia 30905-5301

PERIODICALS
Postage and fees paid
at Augusta, Georgia and
additional cities

OFFICIAL BUSINESS
ISSN 0362-5745

GEN Dennis L. Via returns to the Signal Center of Excellence where he is inducted as a Distinguished Member of the Signal Regiment. Pictured here, GEN Via is presented his Distinguished Member's certificate by Chief of Signal, MG LaWarren V. Patterson.

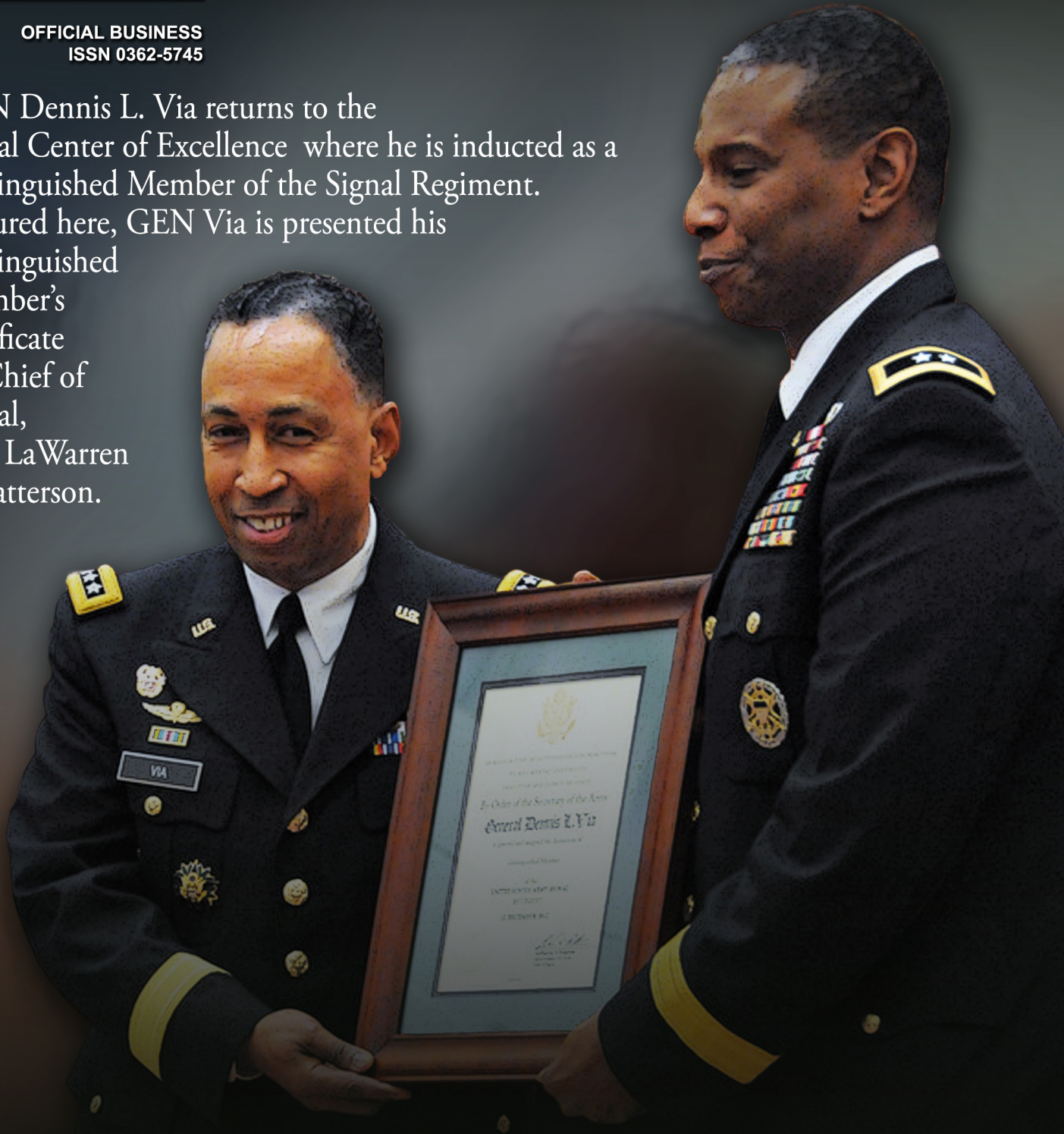

**ARMY
COMMUNICATOR**

Signal Towers, Room 713
Fort Gordon, Georgia 30905-5301
PIN: 103253-000