

**Jump Conditions for Maxwell Equations and Their
Consequences**

by Sikhanda Satapathy and Kuota Hsieh

ARL-RP-465

September 2013

A reprint from *AIP Advances*, Vol. 3, pp. 012120-1–012120-13, 2013.

NOTICES

Disclaimers

The findings in this report are not to be construed as an official Department of the Army position unless so designated by other authorized documents.

Citation of manufacturer's or trade names does not constitute an official endorsement or approval of the use thereof.

Destroy this report when it is no longer needed. Do not return it to the originator.

Army Research Laboratory

Aberdeen Proving Ground, MD 21005-5069

ARL-RP-465

September 2013

Jump Conditions for Maxwell Equations and Their Consequences

Sikhanda Satapathy
Weapons and Materials Research Directorate, ARL

Kuota Hsieh
University of Texas at Austin

A reprint from *AIP Advances*, Vol. 3, pp. 012120-1–012120-13, 2013.

REPORT DOCUMENTATION PAGE			Form Approved OMB No. 0704-0188		
Public reporting burden for this collection of information is estimated to average 1 hour per response, including the time for reviewing instructions, searching existing data sources, gathering and maintaining the data needed, and completing and reviewing the collection information. Send comments regarding this burden estimate or any other aspect of this collection of information, including suggestions for reducing the burden, to Department of Defense, Washington Headquarters Services, Directorate for Information Operations and Reports (0704-0188), 1215 Jefferson Davis Highway, Suite 1204, Arlington, VA 22202-4302. Respondents should be aware that notwithstanding any other provision of law, no person shall be subject to any penalty for failing to comply with a collection of information if it does not display a currently valid OMB control number. PLEASE DO NOT RETURN YOUR FORM TO THE ABOVE ADDRESS.					
1. REPORT DATE (DD-MM-YYYY) September 2013		2. REPORT TYPE Reprint		3. DATES COVERED (From - To) July 2011–December 2012	
4. TITLE AND SUBTITLE Jump Conditions for Maxwell Equations and Their Consequences			5a. CONTRACT NUMBER		
			5b. GRANT NUMBER		
			5c. PROGRAM ELEMENT NUMBER		
6. AUTHOR(S) Sikhanda Satapathy and Kuota Hsieh*			5d. PROJECT NUMBER		
			5e. TASK NUMBER		
			5f. WORK UNIT NUMBER		
7. PERFORMING ORGANIZATION NAME(S) AND ADDRESS(ES) U.S. Army Research Laboratory ATTN: RDRL-WMP-B Aberdeen Proving Ground, MD 21005-5069			8. PERFORMING ORGANIZATION REPORT NUMBER ARL-RP-465		
9. SPONSORING/MONITORING AGENCY NAME(S) AND ADDRESS(ES)			10. SPONSOR/MONITOR'S ACRONYM(S)		
			11. SPONSOR/MONITOR'S REPORT NUMBER(S)		
12. DISTRIBUTION/AVAILABILITY STATEMENT Approved for public release; distribution is unlimited.					
13. SUPPLEMENTARY NOTES A reprint from <i>AIP Advances</i> , Vol. 3, pp. 012120-1–012120-13, 2013. *The University of Texas at Austin, Austin, TX 78712					
14. ABSTRACT We derived the jump conditions for Faraday's induction law at the interface of two contacting bodies in both Eulerian and Lagrangian descriptions. An algorithm to implement the jump conditions in the potential formulation of Maxwell equation is presented. Calculations show that the use of the correct jump conditions leads to good agreement with experimental data, whereas the use of incorrect jump conditions can lead to severe inaccuracies in the computational results. Our derivation resolves the jump condition discrepancy found in the literature and is validated with experimental results.					
15. SUBJECT TERMS Maxwell equation, computational electromagnetics, jump condition					
16. SECURITY CLASSIFICATION OF:			17. LIMITATION OF ABSTRACT	18. NUMBER OF PAGES	19a. NAME OF RESPONSIBLE PERSON
a. REPORT	b. ABSTRACT	c. THIS PAGE			Sikhanda S. Satapathy
Unclassified	Unclassified	Unclassified	UU	18	19b. TELEPHONE NUMBER (Include area code) 410-278-8565

Jump conditions for Maxwell equations and their consequences

Sikhanda Satapathy¹ and Kuota Hsieh²

¹US Army Research Laboratory, RDRL-WMP-B, Aberdeen Proving Ground, MD 21005, USA

²The University of Texas at Austin, Center for Electromechanics, 1 University Station R7000, Austin, TX 78712, USA

(Received 3 July 2012; accepted 11 January 2013; published online 28 January 2013)

We derived the jump conditions for Faraday's induction law at the interface of two contacting bodies in both Eulerian and Lagrangian descriptions. An algorithm to implement the jump conditions in the potential formulation of Maxwell equation is presented. Calculations show that the use of the correct jump conditions leads to good agreement with experimental data, whereas the use of incorrect jump conditions can lead to severe inaccuracies in the computational results. Our derivation resolves the jump condition discrepancy found in the literature and is validated with experimental results. *Copyright 2013 Author(s). This article is distributed under a Creative Commons Attribution 3.0 Unported License.* [<http://dx.doi.org/10.1063/1.4789794>]

I. INTRODUCTION

One of the critical issues in computational modeling of electromagnetic systems containing sliding contacts, such as railguns, is the relationship between electromagnetic quantities on either side of a sliding contact interface. While these interface conditions, called jump-conditions or continuity-conditions are easily derived for stationary contacts, the situation is more complicated for sliding contact surfaces. In the literature there is a clear difference of opinion on the general nature of such jump conditions. The matter is further complicated when one considers two common kinematic descriptions used in computational mechanics, Lagrangian and Eulerian. In the Lagrangian description, the equations are cast in material coordinates, i.e. in a reference frame fixed to the material and deforming with it. In the Eulerian description, on the other hand, the reference frame is fixed in space (laboratory frame.) Irrespective of the choice of reference frame, the field equations in the computational domain and the interface conditions between domains must be independent of the choice of reference frame.

Sommerfeld¹ provides an interesting historical note on how the extension of Maxwell equations for media at rest to media in motion preoccupied Hertz, Lorentz, Minkowski and Einstein. Minkowski finally derived the correct expressions for electromagnetic fields in moving media as follows:

$$\begin{aligned} E^* &= E + u \times B, \text{ and} \\ H^* &= H - u \times D \end{aligned} \quad (1)$$

where E , B , H and D are spatial electric field, magnetic flux density, magnetic field intensity, and electric flux density, respectively, at a fixed location, E^* and H^* are field quantities on the body moving with velocity, u . Since there is no difference of opinion in the literature on the continuity of the normal components of B and current density, j , and since the boundary conditions on H are similar to those on the electric field, we will focus on the interface condition on the electric field in the rest of the paper.

Sommerfeld derived the boundary conditions associated with a moving body, and concluded that the jump conditions associated with Faraday's law for a moving body relative to another depend on the nature of velocity jump at the interface. If the velocity is continuous across the interface, i.e.

if $[[u]] = 0$, where the double square bracket denotes jump in the quantity, then

$$n \times [[E^*]] = 0, \quad (2)$$

but if the velocity is not continuous across the interface, i.e. if $[[u]] \neq 0$, as is the case for sliding contacts, then

$$n \times [[E]] = 0. \quad (3)$$

In essence, Sommerfeld's contention was that if the bodies are at rest relative to each other, the tangential component of relative electric field, E^* is continuous across the boundary. But if the velocity has a jump in the tangential component at the boundary, the spatial electric field (E) is continuous, not E^* . He did not address the condition of a surface discontinuity (such as a shock or an acceleration wave) propagating inside a body, across which there may be a jump in particle velocity.

Lax and Nelson² disagreed with Sommerfeld's conclusion on the boundary condition. They presented a thorough derivation of the relationships between electromagnetic quantities expressed in spatial and material descriptions³ of a deformable body. Specifically, the electric and magnetic fields in spatial (unprimed) and material (primed) frames were shown to be related by,

$$E' = [E + u \times B] \cdot F, \text{ or, } E' \bullet dl' = E^* \bullet dl$$

and

$$B' = JF^{-1} \cdot B, \text{ or, } B' \bullet da' = B \bullet da \quad (4)$$

where $F = \frac{dx}{dX}$ is the two-point deformation gradient tensor, and J is the Jacobian of transformation between the frames. Lax and Nelson's results applied to deformable moving bodies. For rigid bodies, the deformation gradient is the identity tensor, for which case $E^* = E'$. They concluded that the derivation of jump conditions in spatial frame is difficult, which led to the incorrect results of Sommerfeld. Use of a material frame of reference, they argued, would provide the correct jump condition since the material boundaries appear at rest in this frame. Therefore, without stating the proof explicitly, they concluded that the jump in tangential component of the material electric field at the boundary of a moving deforming body is zero. In other words,

$$n \times [[E']] = 0, \quad (5)$$

where E' and n are the electric field and surface normal in Lagrangian frame respectively. For rigid bodies, $F = I$, hence equation (5) reduces to equation (2), which should hold for both stationary and moving rigid bodies. Using this as a starting point, Lax and Nelson derived the boundary conditions in spatial frame. To do so, one must evaluate the jump in the deformation gradient so that equation (4) can be used in equation (5). They argued that the boundary between a conductor and vacuum can be obtained as a limiting process from a boundary between two conducting bodies in intimate contact, provided they do not slip. In this way, their contention was that the gradient of position tangential to the surface is always continuous, and hence the proper jump condition in spatial coordinates from equations (4) and (5) is,

$$n \times [[E^*]] = 0 \quad (6)$$

Use of no-slip argument at the conductor boundary appears to indicate that equation (5) may not apply to the interface at the sliding conductors, where the deformation gradient may not be continuous. However, no restriction was imposed on equation (5), for which the tangential components of the deformation gradient need not be continuous. For rigid bodies, equation (5) and (6) are identical.

³In a material description, the field quantities are measured at a "material" point moving and deforming with the body. In contrast, in Eulerian description the field quantities are measured at a fixed location in space. Material and Lagrangian descriptions are synonymous, as are Eulerian and spatial descriptions. The material quantities are denoted by a prime. A third set of quantities, call relative quantities are also used that are measured in a reference frame moving relative to the material, and are denoted with a "*" superscript.

Therefore, there is a clear contradiction between Sommerfeld's conclusion (eq. (3)) and Lax and Nelson's conclusion (eq. (5) and (6)) for sliding contacts.

For clarity, we restate three definitions of electric field that we have encountered thus far:

E : Electric field in spatial or Eulerian frame, which is measured in a reference frame fixed in space (laboratory frame.) It is only a part of the electric field experienced by a moving particle collocated at the measurement point.

$E^* = E + u \times B$: Electric field measured in a reference frame moving at a speed, u with respect to the laboratory frame. It is the electric field experienced by a particle moving at speed, u with respect to the laboratory frame. It is also the material or Lagrangian electric field in a non-deforming (rigid) body that causes a current flow if a circuit is present.

$E' = (E + u \times B) \cdot F$: Electric field in a deformable body in material or Lagrangian reference frame. The material point has a speed, u and deformation gradient, F . This is the electric field that a sensor mounted on the body would measure. The current in the body is proportional to this material electric field.

II. INTERFACE JUMP CONDITION AT A SLIDING CONTACT

Lax and Nelson's account presented above dealt with "boundary" conditions on moving bodies and vacuum (free surface.) It is not immediately obvious if these conditions would apply to moving interfaces, either inside a body, such as that present across shock waves, or between two bodies in sliding contacts. One may argue that vacuum, in electromagnetism, is a medium that can support the fields unlike in solid mechanics, where a "material" body is necessary to conduct the forces and displacements. Therefore, the boundary conditions derived above would be applicable for internal interfaces or sliding contacts. Extending this thought, the edge of contact between two bodies can be treated as a common boundary with vacuum; therefore the boundary conditions derived for vacuum-conductor interface would at least apply there. However, such arguments do not provide an explicit proof for the continuity condition or jump condition between two sliding bodies.

A few other results exist for motion of discontinuities, or singular surfaces inside a conducting media. Woodson and Melcher³ as well as Jackson⁴ have derived expressions for jump in the electric field across a singular surface moving with a velocity, u normal to the surface itself. In this case, the electric fields on either side of the surface are shown to be related by,

$$n \times \llbracket E \rrbracket = (n \cdot u) \llbracket B \rrbracket \quad (7)$$

This is a slightly more general result than Sommerfeld's jump condition in that it covers motion of a surface discontinuity in the interior of a body. Woodson and Melcher claimed that the tangential velocity had no bearing on the interface condition; only the velocity component normal to the interface is important. Equation (7) can be recast in the following form,

$$n \times \llbracket E_n^* \rrbracket \equiv n \times \llbracket E + (n \cdot u)n \times B \rrbracket = 0 \quad (8)$$

This equation has the same form as equation (6) but only takes the normal velocity of the surface discontinuity into account. Using the vector identity, $a \times b \times c = (a \cdot c)b - (a \cdot b)c$, equation (8) can be recast in the following form.

$$n \times \llbracket E^* \rrbracket = (n \cdot B) \llbracket n \times u \times n \rrbracket \quad (9)$$

since $\llbracket u \cdot n \rrbracket = 0$. The term inside the double square bracket on the right hand side is the tangential component of the velocity. This result implies that the relative electric field, E^* (in a non-deforming body) would not be continuous across an interface in presence of a normal magnetic field and a jump in tangential velocity (i.e. for sliding contacts,) in contradiction with Lax and Nelson's conclusion. Costen and Adamson⁵ recognized the need for a jump condition across a contact surface or an internal surface that moved at an arbitrary velocity different from the material particle velocity. They used an "abstract velocity" to derive a generalized result encompassing arbitrary motion of a surface inside a conductor or between two sliding conductors. However, the purported general solution was identical to equation (7). Maugin and Eringen⁶ derived a more general continuity condition for a

discontinuous surface moving inside a body at an arbitrary orientation with respect to the interface with speed, v , and did not assume that the particle speed, u , across the singular surface is continuous. In such cases, they showed that the jump condition across the singular surface can be expressed as follows.

$$n \times [E^* + (v - u) \times B] = 0 \quad (10)$$

For sliding contact, a distinction must also be made for the B field in two bodies. In the special case, when $v = u$, equation (10) reduces to equation (6) in agreement with Lax and Nelson's condition. In such cases, the interface is a material boundary (topological boundary, or a vortex sheet of order zero, in Truesdell and Toupin's⁷ terminology.) For sliding bodies a conceptual difficulty arises in defining the speed of the interface with respect to the conducting bodies, even though the particle speeds on either side of the interface can be clearly identified. Equation (9) reduces to equation (6) only if one assumes that the speed of the singular surface (i.e. interface) is equal to the speed of the moving body on one side, and equal to the speed of the body on the other side (or equal to zero if the second body is at rest.)

In view of the discussion above, it is clear that there has been significant disagreement on the boundary and interface condition for bodies in relative motion. One view is that the tangential component of the *spatial* electric field, E is continuous across a material interface, whereas the contradicting view is that the tangential component of the *material* electric field, E' (or E^* in absence of deformation) is continuous across a material interface. In the following, we will present a derivation for the jump condition at the interface of two sliding bodies, which in essence proves Lax and Nelson's conclusion and removes the ambiguity in the continuity condition for sliding interfaces. We will finally show that computation with this jump conditions gives good agreement with experimental data, whereas use of Sommerfeld's condition disagrees with the experimental results. The computations are done with finite element method. The implementation of the Maxwell equation and the jump condition in this numerical method will also be described.

III. JUMP CONDITION AT A MATERIAL INTERFACE

In the derivation of the jump conditions in this section, we will apply Faraday's induction law to three different loops: a loop fixed to a spatial location (Eulerian), a loop fixed to the original material configuration (Lagrangian), and a loop deforming with the material (material loop.) It will be shown that all three methods result in the same jump condition that the tangential component of material electric field, E' is continuous across a sliding interface.

Consider two bodies, "A" and "B" separated by a "shear layer (SL.)" The body-B moves with speed u in x-direction relative to body-A. Since we consider the jump condition at any instance of time, no restriction is placed on time variation of the sliding velocity. The top of the shear layer is attached (no-slip condition) to body-A and the bottom is attached to body-B. As a result, it deforms (shears) with time. The field variables are assumed to be constant in the shear layer. This does not pose any problem for sliding contact case, since the shear layer will be taken to the zero thickness limit. The non-zero thick shear layer solution will be limited to cases where the field is constant through the shear layer thickness. Consider an Eulerian loop PQRSTUUVW encompassing a portion of the stationary body-A, the shear layer, and the moving body-B. The PQRW part of the loop is in body-A, RSVW part is in the shear layer, and the STUV part of the loop is in body-B. Let the material loop that was coincident with the Eulerian loop at time, t_n deform to PQRS'T'U'V'W at time t_{n+1} .

A. Eulerian Description

In Eulerian description, we focus at a spatial location. Therefore, we consider only the fixed loop PQRSTUUVW. The surface enclosed by this loop has different velocities in different parts, unlike the Lagrangian loop considered in the following section. Applying the Faraday's induction equation around this loop.

We start with the material (Lagrangian) form of Faraday's induction law (as was originally observed in experiments.)

$$\oint E' \cdot dl' = -\frac{d}{dt} \int_{S'} B' \cdot dA \quad (11)$$

In view of the transformation laws stated in equation (4), equation (11) can be expressed in an Eulerian description for the deforming body as follows.

$$\oint E^* \cdot dl = -\frac{d}{dt} \int_s B \cdot da \quad (12)$$

where dl and da refer to the differential length and area, respectively, of the deforming body in spatial coordinates. Using Reynold's transport theorem, the right hand side of equation (12) can be expanded to obtain,

$$\oint E^* \cdot dl = -\frac{\partial}{\partial t} \int_s B \cdot da - \int_s (\nabla \cdot B) u \cdot da + \int_s \nabla \times (u \times B) \cdot da. \quad (13)$$

The middle term on the RHS is zero since $\nabla \cdot B = 0$. The last term on the r.h.s. can be converted to a line integral using Stoke's theorem to obtain the Eulerian form of the induction law as follows.

$$\oint E^* \cdot dl = -\frac{\partial}{\partial t} \int_s B \cdot da + \oint (u \times B) \cdot dl \quad (14)$$

Note that the use of Stoke's theorem implies that the quantity $(u \times B)$ is unique in the domain of integration.

Now, evaluation of equation (14) around the loop PQRSTUWV yields,

$$\begin{aligned} & (E_{PQ}^{*A} - E_{TU}^{*B}) \cdot (L\vec{k}) + (E_{QR}^{*A} - E_{WP}^{*A}) \cdot (\delta_1 \vec{j}) + (E_{RS}^{*SL} - E_{VW}^{*SL}) \cdot (\varepsilon \vec{j}) + (E_{ST}^{*B} - E_{UV}^{*B}) \cdot (\delta_2 \vec{j}) \\ & = \frac{\partial}{\partial t} [B_x|_{PQRW} \delta_1 L + B_x|_{RSVW} \varepsilon L + B_x|_{STUV} \delta_2 L] - [-B_y u^A L + B_y u^B L] \end{aligned} \quad (15)$$

Taking the limits $\delta_1 \rightarrow 0$, $\delta_2 \rightarrow 0$, and $\varepsilon \rightarrow 0$, and cancelling out L from both sides, we obtain,

$$n \times (E^{*A} - E^{*B}) = (B \cdot n)(u^A - u^B) \quad (16)$$

Therefore, in presence of a normal magnetic field, the difference of electric field, E^* across a shear layer is non-zero. The question is can this equation be taken to a limiting case of zero-shear layer thickness case to obtain a jump condition on the electric field for sliding contacts? If it can be, then the result would be in contradiction with Lax and Nelson's results as well as with Maugin and Eringen's results (at least for the case when $v = u!$) but would be in agreement with Sommerfeld's conclusion. It turns out that while the derivation is correct for a continuous media, with a thin enough shear-layer bridging two solids where the fields can be assumed to be constant, it doesn't apply to a contact surface or a discontinuous surface. The limit $\varepsilon \rightarrow 0$ cannot be taken without violating the underlying assumption of continuous integrand in Stoke's theorem as used in equation (14). The standard form of Stoke's theorem (that was employed in obtaining equation (14)) applies only for cases where the integrand is uniquely defined throughout the domain of integration (see for example Greenberg)⁸ If the surface of integration includes a singular curve where the integrand is not continuous, the modified Stoke's law (see for example Eringen)⁹ is given by,

$$\int_{S-\gamma} \nabla \times A \cdot da = \oint_{C-\gamma} A \cdot dl - \int_{\gamma} [[A]] \cdot dl \quad (17)$$

where γ is the singular curve inside S. Therefore, equation (14) needs to be modified to,^b

$$\oint E^* \cdot dl = -\frac{\partial}{\partial t} \int_{S-\gamma} B \cdot da - \oint_{C-\gamma} (u \times B) \cdot dl - \int_{\gamma} \llbracket u \times B \rrbracket \cdot dl \quad (18)$$

In the limit, $S \rightarrow 0$, the first term on the RHS becomes zero. Evaluation of the last two terms around the loop indicates,

$$\begin{aligned} & (E_{PQ}^{*A} - E_{TU}^{*B}) \cdot (L\vec{k}) + (E_{QR}^{*A} - E_{WP}^{*A}) \cdot (\delta_1 \vec{j}) + (E_{RS}^{*SL} - E_{V'W}^{*SL}) \cdot (\varepsilon \vec{j}) + (E_{ST}^{*B} - E_{UV}^{*B}) \cdot (\delta_2 \vec{j}) \\ &= \frac{\partial}{\partial t} [B_x|_{PQRW} \delta_1 L + B_x|_{RSVW} \varepsilon L + B_x|_{STUV} \delta_2 L] - [B_y u^A L + B_y u^B L] + [-B_y u^A L + B_y u^B L] \end{aligned} \quad (19)$$

Now that the internal discontinuity or non-unique velocity has been taken into account, the limit $\varepsilon \rightarrow 0$ can be taken without any error. Thus in the limit, $\delta_1 \rightarrow 0$, $\delta_2 \rightarrow 0$, and $\varepsilon \rightarrow 0$, we obtain, $L(E_{PQ}^{*A} - E_{TU}^{*B}) \cdot \vec{k} = 0$. Similarly, by taking a loop in orthogonal plane considered here, it can be shown that $L(E_{PQ}^{*A} - E_{TU}^{*B}) \cdot \vec{i} = 0$. Hence,

$$n \times \llbracket E^* \rrbracket = 0 \quad (20)$$

Therefore, we have arrived at a jump condition across a sliding surface that is consistent with Lax and Nelson's conclusion for conductor-vacuum interface. We did not impose any restriction on the continuity of deformation gradient or slippage between surfaces. Therefore, this result is more general than Lax and Nelson's result and applies to sliding contact interfaces described in Eulerian description. It also removes the difficulty associated with defining a unique sliding surface velocity in Maugin and Eringen's results. Another important point to note is that equation (16) is correct for continuous media, or two bodies joined by a shear-layer whose edges are attached to the two bodies on either side. However, the correct jump condition can't be obtained by successively reducing the shear-layer thickness to zero, since in this limit the assumption of continuous (unique) velocity field is violated. In presence of a normal magnetic field, there will be always a difference between the tangential electric fields across the shear layer in the bodies themselves. Since a non-zero thick shear layer ensures continuity of velocity at any point, the jump in u is zero leading to identical results between equations (16) and (20).

B. Lagrangian description

There are two ways to derive jump condition of material E' , one is to apply the induction law to a fixed material loop PQRSTUWV as in Figure 1, and the other to apply to a deformable material loop (embedded in the material) that deforms from the initial position PQRSTUWV at time t_n to PQRST'U'V'W at time t_{n+1} .

The body surface is at rest in the Lagrangian loop, i.e. materials do not have velocity with respect to the Lagrangian frame, since the surface enclosed by the loop deforms with material points. Let's apply Faraday's law to this loop. Integrating Faraday's induction equation,

$$\oint E' \cdot dL = -\frac{d}{dt} \int_S B' \cdot dA \quad (21)$$

^bAs a corollary, cancelling out the integral of $u \times B$ from both sides of equation (18), the Eulerian form of Faraday's law becomes $\oint E \cdot dl = -\int_{S-\gamma} \frac{\partial B}{\partial t} \cdot da - \int_{\gamma} \llbracket u \times B \rrbracket \cdot dl$ for a loop containing a discontinuity.

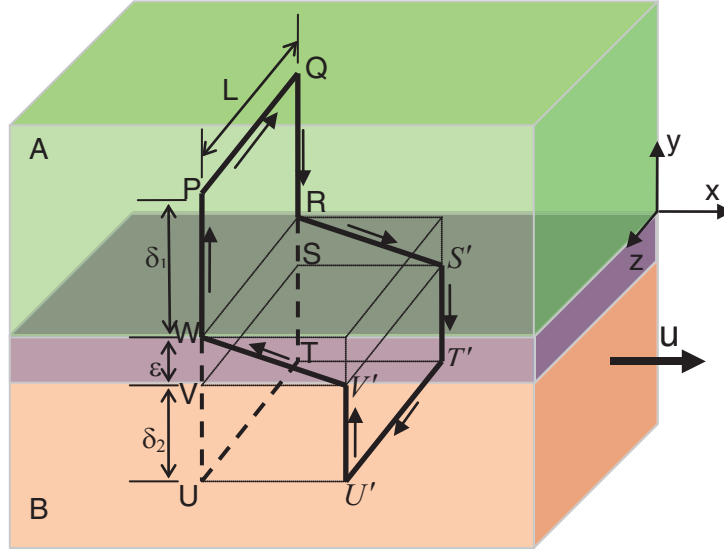

FIG. 1. Sliding contact showing two bodies “A” and “B” having a relative motion, separated by a shear-layer. Integration contours are shown.

around the loop, we obtain,

$$\begin{aligned}
 & -L(E'_{PQ}{}^A - E'_{T'U'}{}^B) \cdot \vec{k} - \delta_1(E'_{QR}{}^A - E'_{WP}{}^A) \cdot \vec{j} + (E'_{RS'}{}^B - E'_{V'W}{}^B) \cdot (u\Delta t\vec{i} - \varepsilon\vec{j}) \\
 & - \delta_2(E'_{S'T'}{}^B - E'_{U'V'}{}^B) \cdot \vec{j} \\
 & = \frac{B'(t_{n+1}) \cdot dA|_{PQRW} - B'(t_n) \cdot dA|_{PQRW}}{\Delta t} + \frac{B'(t_{n+1}) \cdot dA|_{RS'V'W} - B'(t_n) \cdot dA|_{RSVW}}{\Delta t} \\
 & + \frac{B'(t_{n+1}) \cdot dA|_{S'T'U'V'} - B'(t_n) \cdot dA|_{STUV}}{\Delta t}
 \end{aligned} \quad (22)$$

As $\delta_1 \rightarrow 0$, $\delta_2 \rightarrow 0$ and $\varepsilon \rightarrow 0$, the differential area dA tends to zero. Hence the RHS is zero. Further as $\Delta t \rightarrow 0$, the only term that survives is the first term on the LHS. Therefore, in these limits,

$$L(E'_{PQ}{}^A - E'_{T'U'}{}^B) \cdot \vec{k} = 0, \quad \text{or } \llbracket E' \rrbracket \cdot \vec{k} = 0 \quad (23)$$

Similarly, it can be shown that $\llbracket E' \rrbracket \cdot \vec{i} = 0$. Therefore, the interface jump condition for the electric field is given by,

$$n \times \llbracket E' \rrbracket = 0 \quad (24)$$

This result is identical to that in Lax and Nelson.

Finally, the jump condition on $n \times E^*$ also can be derived from E^* by applying Faraday's induction law to a deformable material loop. Starting with the induction law for deforming body (eq. (12)), and integrating around the loop $PQRS';T'U'V'W$, we obtain,

$$\begin{aligned}
 & (E_{PQ}^{*A} l_{PQ} - E_{T'U'}^{*B} l_{T'U'}) \cdot \vec{k} + (E_{QR}^{*A} \delta_1^{QR} - E_{WP}^{*A} \delta_1^{WP}) \cdot \vec{j} + (E_{RS'}^{*B} - E_{V'W}^{*B}) \cdot (u\Delta t\vec{i} - \varepsilon\vec{j}) \\
 & + (E_{S'T'}^{*B} \delta_2^{S'T'} - E_{U'V'}^{*B} \delta_2^{U'V'}) \cdot \vec{j} \\
 & = \frac{B(t_{n+1}) \cdot da|_{PQRW} - B(t_n) \cdot da|_{PQRW}}{\Delta t} + \frac{B(t_{n+1}) \cdot da|_{RS'V'W} - B(t_n) \cdot da|_{RSVW}}{\Delta t} \\
 & + \frac{B(t_{n+1}) \cdot da|_{S'T'U'V'} - B(t_n) \cdot da|_{STUV}}{\Delta t}
 \end{aligned} \quad (25)$$

Using the relationship between Lagrangian and Eulerian quantities for a moving, deforming body, $E^* \cdot dl = E' \cdot dl'$, and $B' \cdot da' = B \cdot da$ (equation (4)) and the relations $l_{T'U'} = Fl_{TU}$, $\delta_2^{S'T'} = F\delta_2$, etc, we obtain,

$$\begin{aligned} & (E_{PQ}^{*A} F \cdot l_{PQ} - E_{T'U'}^{*B} F \cdot l_{TU}) \cdot \vec{k} + (E_{QR}^{*A} \delta_1^{QR} - E_{WP}^{*A} \delta_1^{WP}) \cdot \vec{j} + (E_{RS'}^{*B} - E_{V'W}^{*B}) \cdot (u\Delta t \vec{i} - \varepsilon \vec{j}) \\ & + (E_{S'T'}^{*B} F \cdot \delta_2 - E_{U'V'}^{*B} F \cdot \delta_2) \cdot \vec{j} \\ & = \frac{B(t_{n+1}) \cdot da|_{PQRW} - B(t_n) \cdot da|_{PQRW}}{\Delta t} + \frac{B(t_{n+1}) \cdot da|_{RS'V'W} - B(t_n) \cdot da|_{RSVW}}{\Delta t} \\ & + \frac{B(t_{n+1}) \cdot da|_{S'T'U'V'} - B(t_n) \cdot da|_{STUV}}{\Delta t} \end{aligned} \quad (26)$$

Taking the limit as $\delta_1 \rightarrow 0$, $\delta_2 \rightarrow 0$, $\varepsilon \rightarrow 0$, and $\Delta t \rightarrow 0$, we obtain,

$$l(E_{PQ}'^A - E_{TU}'^B) \cdot \vec{k} = 0 \quad (27)$$

Hence, $[[E']] \cdot \vec{k} = 0$. Similarly, it can be shown that $[[E']] \cdot \vec{i} = 0$. Therefore, the interface jump condition for the electric field is given by,

$$n \times [[E']] = 0 \quad (28)$$

This result is identical to that derived in Lagrangian reference frame earlier, as it should be.

IV. EVALUATION OF JUMP CONDITION EFFECTS IN SLIDING CONTACT

We used a finite element code, EMAP3D^{10,11} to evaluate the implication of the jump conditions across the contact surface. The intent was to compare the results with experimental data later. Since our finite element method implementation is based on discretization of electric scalar potential and magnetic vector potential using nodal elements, we first express the jump conditions in terms of potentials and then describe how they are implemented in the finite element formulation.

For clarity, we will denote primed-variables, A' , B' , E' in material (Lagrangian) representation, and unprimed variables, A , B , E , etc. in spatial (Eulerian) representation. Similarly, the gradient in material frame is denoted by a prime. The material representation of electric potential φ is φ' . Let's start with the integral form of Faraday's induction law.

$$\oint_{\Gamma} E' \cdot dl' = -\frac{d}{dt} \int_{\Omega} B' \cdot dA' \quad (29)$$

Defining B' as curl of a vector potential, A' , i.e. $B' = \nabla' \times A'$, the electrical field can be expressed as,

$$E' = -\frac{dA'}{dt} - \nabla' \varphi', \quad (30)$$

where φ' is the material electric scalar potential. Equations (29) and (30) take identical form in spatial description in view of Minkowski relation in equation (1) and Lax and Nelson's result in equation (4), e.g. $E = -\frac{dA}{dt} - \nabla \varphi$. The connection between the spatial and material potentials can be easily established. Adding $u \times B$ term to both sides of the expression for spatial electric field, E , and some vectorial manipulation, we obtain,

$$E + u \times B = \left[-\frac{d}{dt} (A \cdot F) - \nabla' (\varphi - A \cdot u) \right] \cdot F^{-1} \quad (31)$$

where $F = \partial x / \partial X$, the deformation gradient. Since the material description of the electric field,² $E' = (E + u \times B) \cdot F$ we obtain,

$$A' = A \cdot F \text{ and } \varphi' = \varphi - A \cdot u \quad (32)$$

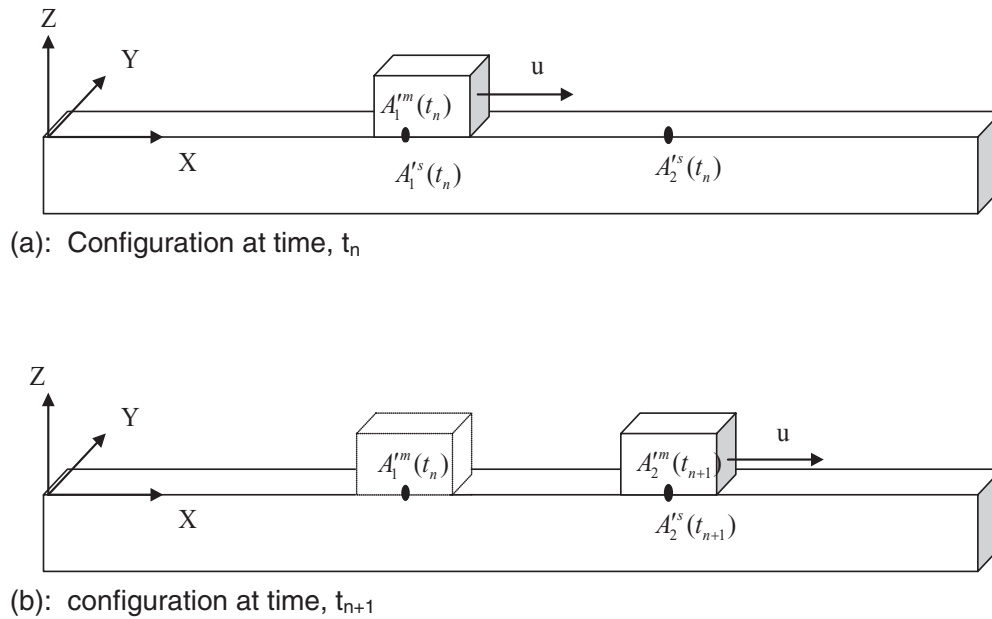

FIG. 2. Time evolution of the configuration of the sliding contact.

These relationships between Eulerian and Lagrangian potentials are the same as that derived by Lax and Nelson. Since we used nodal elements, the next question is: do continuity of A' and φ' violate any jump condition? A careful examination of equations (14) and (21) indicates that the jump conditions for E' depend on $\nabla'\varphi'$, not on φ' itself. From equation (14) the jump condition in the tangential plane in terms of the potentials can be written as follows.

$$\llbracket E' \rrbracket_j = \left[\left[-\frac{dA'}{dt} \right] \right]_j - \llbracket \nabla'\varphi' \rrbracket_j = 0 \quad (33)$$

Does this jump condition in tangential components of the gradients of the potentials create any problem if one assumes continuity of A' and φ' ? The first term on the RHS has a non-zero jump as shown later. The second term on the RHS must have a non-zero jump to be able to cancel out the jump in the first term. To enforce the jump condition at the interface, the gradients can be treated as unknowns in the interface (without changing the continuity assumption on the potentials.) This is a more accurate way to enforce the jump condition as compared to enforcing it through discontinuous φ' , even though the latter method is valid and results in fewer unknowns.

Let's consider the situation as described in the Figure 2. The superscripts "m" and "s" denote moving and stationary conductor, respectively. The moving conductor moves from location-1 to location-2. The location is denoted by the subscripts in the variable A' . Let's evaluate jump in E' .

$$\begin{aligned} n \times \llbracket E'(t_{n+1}) \rrbracket &= n \times \left[\left[-\frac{dA'}{dt} - \nabla'\varphi' \right] \right] \\ &= -n \times \left[\frac{A_2^m(t_{n+1}) - A_1^m(t_n)}{\Delta t} - \frac{A_2^s(t_{n+1}) - A_2^s(t_n)}{\Delta t} \right] - n \times [\nabla'\varphi'^m - \nabla'\varphi'^s] \\ &= -n \times \left[\frac{A_2^s(t_n) - A_1^s(t_n)}{\Delta t} \right] - n \times [\nabla'\varphi'^m - \nabla'\varphi'^s] \end{aligned} \quad (34)$$

The continuity condition on A' , i.e. $A_2^m(t_{n+1}) = A_2^s(t_{n+1})$; $A_1^m(t_n) = A_1^s(t_n)$ is used in the above equation. A careful look at the above equation shows that the jump in the first bracket on RHS is not zero, since the vector potentials refer to different locations. This term is really the $u \cdot \nabla A'$ term

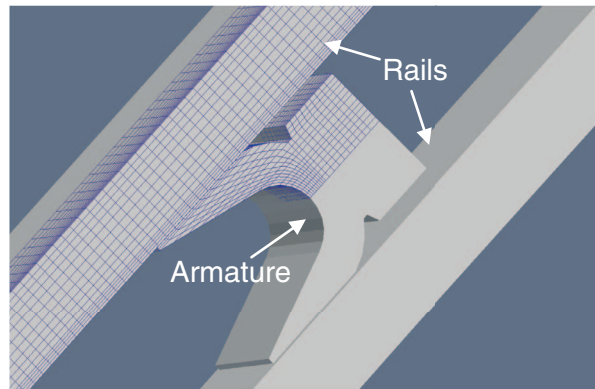

FIG. 3. Computational model of the armature and rails. Only a quarter of the model need be meshed for finite element analysis exploiting two orthogonal planes of symmetry.

in Eulerian description. Therefore, the jump in E' at the interface can be explicitly enforced by requiring that

$$n \times [\nabla\phi^m - \nabla\phi^s] = n \times \left[\frac{A_2^s(t_n) - A_1^s(t_n)}{\Delta t} \right] \quad (35)$$

As stated earlier, this condition can be easily implemented by either treating the tangential component of the gradients as unknown in the interface, or by using discontinuous potential at nodes. The former method is more accurate while the latter is less computationally intensive.

V. COMPARISON WITH EXPERIMENTS

Measuring the jump in the electric field across a sliding electric contact is not a trivial matter. Therefore, the analytical results must be validated against indirect measurement of the jump condition effects. The railgun experiment offers an excellent means to study the effects of jump condition on the interface, since it has a great bearing on the current through the armature and hence the Lorentz force generated, as will be evident from the following results. We compare our computed results with two different jump conditions in this section with two different railgun experiments. These experiments contain sliding electric contacts, and hence are appropriate to test the jump condition differences. In a railgun, an armature is propelled by electromagnetic force. Two stationary conductors (rails) are connected to a capacitor bank. An armature, typically a solid piece of metal, is placed between the rails to complete the circuit. The electromagnetic force accelerates the armature, which slides on the rail surface and pushes the launch package ahead of it. The launch force in a simple railgun is proportional to the inductance gradient and square of the applied current. The inductance gradient is a function of the rail geometry that can be computed irrespective of the armature design.

The jump conditions in eqs. (3) and (5) show a difference in the jump in material (Lagrangian) electric field in presence of sliding electric contact. The jump indicated by equation (3) implies the condition in equation (9) that the jump in tangential electric field across the sliding interface is proportional to the normal magnetic field at the rail-armature interface, and to the velocity of the accelerating armature. Since the launch force is proportional to the square of applied current, which in turn is a function of material electric field in the conductors, a clear difference in velocity prediction is expected with the two jump conditions.

We compare our results with two railgun experiments.^{12,13} The first one was conducted on IAT's medium caliber launcher (MCL) and the second test was done on IAT's small scale launcher (SCL.) The MCL test¹² used ETP copper rails with Al 7075 armatures weighing 319 g. The bore size was 40×40 mm in cross-section, 7 m long. The computational geometry is shown in Figure 3. It consists of a rail and armature (shown) and surrounding air space (not shown). Since rail-guns are symmetrical by design, we can completely characterize the problem by modeling a quarter of the gun. The

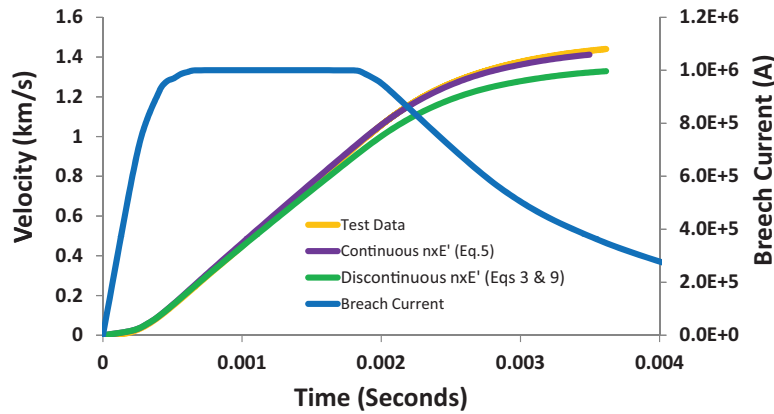

FIG. 4. The MCL velocity data shows better agreement with eq. (5).

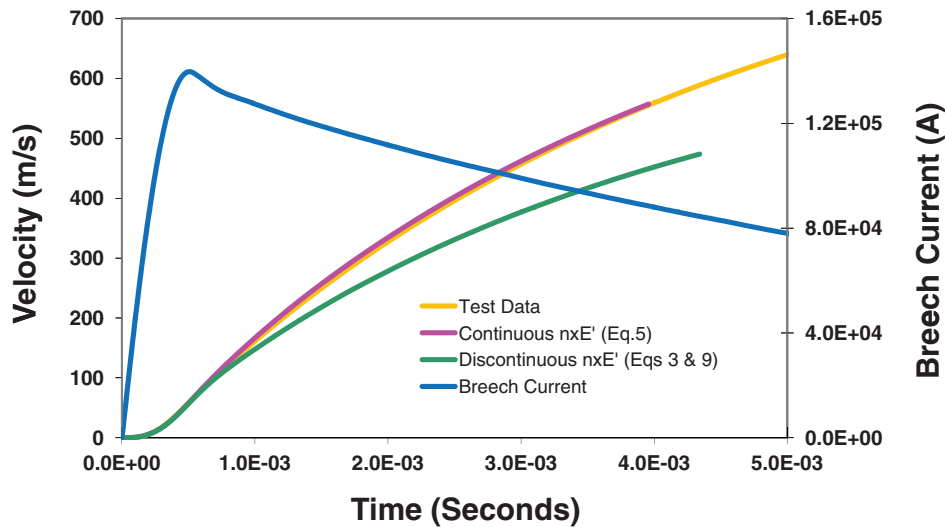

FIG. 5. The SCL velocity data shows that non-zero jump in E' diverges from the test data progressively as the velocity increases.

SCL experiment¹³ was similar to the MCL experiment, except for different dimensions. It used a 25×25 mm rail bore with copper rails and a 25 g aluminum armature.

Figures 4 and 5 show the armature velocity profile obtained from the computations and the two experiments. It is evident from the plot that the jump condition of eq. (5) tracks the experimental data much better than the jump condition suggested by eq. (9). In addition, the discrepancy between the experiment and discontinuous E' jump condition increases with velocity as expected from eq (9) since the jump is proportional to the velocity. Therefore, the experimental results support the conclusion that the tangential component of the *material* electric field is continuous across a sliding electric contact.

In Figure 6 we plot the magnetic field amplitude and current density vector field. Figure 7 shows the magnetic field vectors and current density magnitude. For continuous material electric field at the interface, the magnetic field and current density distribution appear to diffuse into the interface from the edges, with higher edge fields seen in the leading edge of the armature. This appears reasonable since the magnetic flux ahead of the armature is crowded due to motion, resulting in a higher gradient in magnetic field there. This produces higher current density in the leading edge. On the other hand, with a discontinuous material electric field at the interface, the magnetic field and current densities are skewed towards the outer edge of the armature. The field distributions are

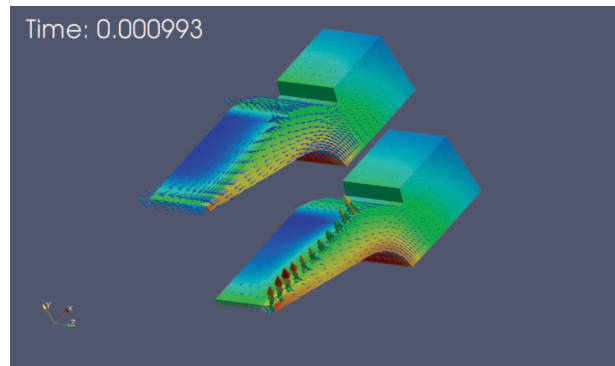

FIG. 6. The contour plot shows magnetic field magnitude and the vector plot shows the current density distribution for no-jump in E' (eq. (5)) in the upper plot and with a jump in E' (eq. (3)) in the lower plot.

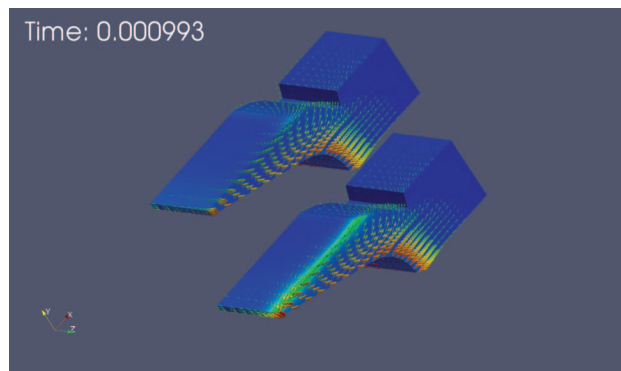

FIG. 7. The contour plot shows current density magnitude and the vector plot shows the magnetic field for no-jump in E' (eq. (5)) in the upper plot and with a jump in E' (eq. (3)) in the lower plot.

substantially different between the two cases, and would affect temperature distribution and interface phenomena such as erosion. Therefore, the simulation accuracy and utility critically depend on the correct jump condition.

VI. SUMMARY

Difference of opinion exists in the literature on the jump condition arising out of Maxwell equation at interface of bodies in relative motion. We presented a rigorous derivation of the interface condition, which showed that the material tangential electric field must be continuous at material interfaces. A mere use of a shear layer in the interface to remove discontinuity in the velocity is inadequate to obtain the correct continuity condition. The jump condition is indeed identical in both Eulerian and Lagrangian reference frames. Our finite element simulations of railgun experiments validated our conclusion that the material tangential electric field must be continuous. We showed that the use of discontinuous material tangential electric field at the interface leads to monotonic deviation of computed velocity from experimental data, as suggested by the non-zero jump term.

¹A. Sommerfeld, *Electrodynamics* (Academic Press, New York, 1952).

²M. Lax and D. F. Nelson, *Phys. Rev. B* **13**, 1777 (1976).

³Woodson and Melcher, *Electromechanical dynamics: part-I* (John Wiley and Sons, 1968).

⁴J. D. Jackson, *Classical Electrodynamics* (John Wiley and Sons, 1998).

⁵R. C. Costen and D. Adamson, "Three dimensional derivation of the electrodynamic jump conditions and momentum-energy laws at a moving boundary," *Proceedings of IEEE* **53**(9), 1187 (1965).

⁶G. A. Maugin and A. C. Eringen, *Electrodynamics of continua-I* (Springer, 1989).

- ⁷C. Truesdell and R. A. Toupin, "The classical field theories," in *Handbook of Physics* edited by S. Flugge (Springer-Verlag, Berlin, 1960).
- ⁸M. Greenberg, *Advanced Engineering Mathematics*, 2nd edition (Prentice Hall, 1998).
- ⁹A. C. Eringen, *Mechanics of Continua* (John Wiley and Sons, New York).
- ¹⁰K. T. Hsieh, "A Lagrangian formulation for mechanically, thermally coupled electromagnetic diffusive processes with moving conductors," *IEEE Trans. on Mag.* **31**, 605–609 (1995).
- ¹¹K. T. Hsieh and S. Satapathy, "Plasticity model in EMAP3D," *IEEE Trans. Mag.* **39**(1), 142–147 (2003).
- ¹²H. Vanicek and S. Satapathy, "Thermal characteristics of a Laboratory EM Launcher," *IEEE Transaction on Magnetics* **41**(1), 251 (2005).
- ¹³M. Crawford, "Evaluation of B-dot cards to determine axial location of rail-to-armature current," *14th EML conference, Belgium, 2009*.

NO. OF
COPIES ORGANIZATION

1 DEFENSE TECHNICAL
(PDF) INFORMATION CTR
DTIC OCA

1 DIRECTOR
(PDF) US ARMY RESEARCH LAB
IMAL HRA

1 DIRECTOR
(PDF) US ARMY RESEARCH LAB
RDRL CIO LL

1 GOVT PRINTG OFC
(PDF) A MALHOTRA

1 CTR FOR ELECTROMECHANICS
(PDF) THE UNIV OF TEXAS AT AUSTIN TX
K T HSIEH

1 NSWC
(PDF) K LEWIS

1 NAVAL RESEARCH LAB
(PDF) J MICHPOULOS

1 IAP RSRCH INC
(PDF) J BARBER

1 UNIV OF TEXAS-AUSTIN
(PDF) DEPT OF MECH ENGRG
M BRYANT

1 UNIV OF TEXAS-AUSTIN
(PDF) ADVANCED MANUFACTURING CTR
COCKRELL SCHOOL OF ENGRG
T WATT

1 UNIV OF TEXAS-ARLINGTON
(PDF) DEPT OF ELECTRICAL ENGRG
D WETZ

1 INSTITUTE FOR STRATEGIC AND
(PDF) INNOVATIVE TECHNOLOGIES
H FAIR