

Sb-Based n- and p-Channel Heterostructure FETs for High-Speed, Low-Power Applications

J. Brad BOOS^{†a)}, Brian R. BENNETT[†], Nicolas A. PAPANICOLAOU[†], Mario G. ANCONA[†], James G. CHAMPLAIN[†], Yeong-Chang CHOU^{††}, Michael D. LANGE^{††}, Jeffrey M. YANG^{††}, Robert BASS[†], Doewon PARK[†], and Ben V. SHANABROOK[†], *Nonmembers*

SUMMARY Heterostructure field-effect transistors (HFETs) composed of antimonide-based compound semiconductor (ABCS) materials have intrinsic performance advantages due to the attractive electron and hole transport properties, narrow bandgaps, low ohmic contact resistances, and unique band-lineup design flexibility within this material system. These advantages can be particularly exploited in applications where high-speed operation and low-power consumption are essential. In this paper, we report on recent advances in the design, material growth, device characteristics, oxidation stability, and MMIC performance of Sb-based HEMTs with an InAlSb upper barrier layer. The high electron mobility transistors (HEMTs) exhibit a transconductance of 1.3 S/mm at $V_{DS} = 0.2$ V and an $f_T L_g$ product of 33 GHz- μm for a 0.2 μm gate length. The design, fabrication and improved performance of InAlSb/InGaSb p-channel HFETs are also presented. The HFETs exhibit a mobility of 1500 $\text{cm}^2/\text{V}\cdot\text{sec}$, an f_{max} of 34 GHz for a 0.2 μm gate length, a threshold voltage of 90 mV, and a subthreshold slope of 106 mV/dec at $V_{DS} = -1.0$ V.

Key words: HEMTs, HFETs, MMICs, InAs, InGaSb

1. Introduction

There is an expanding need to reduce power consumption in high-speed analog, digital, and mixed-signal circuits for military and commercial applications. Sb-based heterostructure devices have intrinsic high-speed and low-power consumption advantages that can provide the enabling technology needed for these applications, which include space-based communications, imaging, sensing, identification, high-data-rate transmission, micro-air-vehicles, wireless and other portable systems.

The low dc power consumption of AlSb/InAs HEMTs is attractive for large-scale active-array space-based radar applications which are particularly power-constrained. An f_T value of 110 GHz has been measured at $V_{DS} = 100$ mV and circuit demonstrations at L-, S-, X-, Ka-, and W-band have exhibited record low power dissipation [1]–[4]. Displacement damage radiation measurements show that they are also the most radiation tolerant HEMTs tested to date [5].

Recently, there has been considerable interest in the potential of III-V FET materials for advanced logic applications [6], [7]. A III-V high-speed, low-power complementary logic technology could enhance digital circuit

functionality and sustain Moore's law for additional generations. When utilized in mixed signal circuits, a significant reduction in power consumption could also be obtained. For these applications, complementary circuits in the Sb-based material system would be highly desirable due to their low-power, high-speed advantages. To this end, p-channel HFETs having high hole mobility would be required.

In order to enhance the performance and reliability of Sb-based HEMTs and p-channel HFETs, the use of InAlSb as the upper barrier layer material has been investigated. When combined with an AlGaSb buffer layer, this design eliminates the use of the highly reactive AlSb material within the structure and simplifies the growth of an n^+ or p^+ cap layer above the InAlSb layer to enable lower access resistance [8]. In Sects. 2 and 3, we report on recent advancements at our laboratories on Sb-based HEMT material growth, fabrication, device characteristics, and MMIC performance utilizing this approach. In Sect. 4, recent developments on p-channel InAlSb/InGaSb HFETs at the Naval Research Laboratory are presented.

2. InAlSb/InAs HEMTs

The HEMT material was grown by solid-source molecular beam epitaxy (MBE) on a semi-insulating (100) GaAs substrate. Details of the growth procedures have been published elsewhere [9], [10]. A cross section of the material layer design is shown in Fig. 1. A 1.5 μm thick undoped $\text{Al}_{0.7}\text{Ga}_{0.3}\text{Sb}$ buffer layer is used to accommodate the 7% lattice mismatch. The upper barrier is 130 Å of $\text{In}_{0.2}\text{Al}_{0.8}\text{Sb}$. A GaTe source is used for Te delta-doping 65 Å above the channel. The electron sheet carrier density and mobility of the starting material at 300 K were measured to be $0.9 \times 10^{12} \text{ cm}^{-2}$ and 19,000 $\text{cm}^2/\text{V}\cdot\text{s}$, respectively.

X-ray diffraction measurements demonstrate that the channel and upper barrier layers are nearly coherent with respect to the relaxed AlGaSb buffer layer, with the InAs in tension (1.1% mismatch) and the InAlSb in compression (1.3% mismatch). The electron density in the channel was controlled by varying the Te dose, with room-temperature mobilities between 18,000 and 25,000 $\text{cm}^2/\text{V}\cdot\text{s}$ for densities between 0.9×10^{12} and $2.4 \times 10^{12}/\text{cm}^2$.

The HEMTs were fabricated using evaporated Pd/Pt/Au source and drain ohmic contacts which were defined using PMMA resist and deep-UV lithography. The contacts were heat treated using a hot-plate. The gate was then

Manuscript received January 31, 2008.

[†]The authors are with the Naval Research Laboratory, Washington, DC, 20375 USA.

^{††}The authors are with Northrop Grumman Space Technology, One Space Park, Redondo Beach CA, 90278 USA.

a) E-mail: 6876@nrl.navy.mil

DOI: 10.1093/ietele/e91-c.7.1050

Report Documentation Page

Form Approved
OMB No. 0704-0188

Public reporting burden for the collection of information is estimated to average 1 hour per response, including the time for reviewing instructions, searching existing data sources, gathering and maintaining the data needed, and completing and reviewing the collection of information. Send comments regarding this burden estimate or any other aspect of this collection of information, including suggestions for reducing this burden, to Washington Headquarters Services, Directorate for Information Operations and Reports, 1215 Jefferson Davis Highway, Suite 1204, Arlington VA 22202-4302. Respondents should be aware that notwithstanding any other provision of law, no person shall be subject to a penalty for failing to comply with a collection of information if it does not display a currently valid OMB control number.

1. REPORT DATE JAN 2008	2. REPORT TYPE	3. DATES COVERED 00-00-2008 to 00-00-2008			
4. TITLE AND SUBTITLE Sb-Based n- and p-Channel Heterostructure FETs for High-Speed, Low-Power Applications		5a. CONTRACT NUMBER			
		5b. GRANT NUMBER			
		5c. PROGRAM ELEMENT NUMBER			
6. AUTHOR(S)		5d. PROJECT NUMBER			
		5e. TASK NUMBER			
		5f. WORK UNIT NUMBER			
7. PERFORMING ORGANIZATION NAME(S) AND ADDRESS(ES) Naval Research Laboratory, 4555 Overlook Avenue SW, Washington, DC, 20375		8. PERFORMING ORGANIZATION REPORT NUMBER			
9. SPONSORING/MONITORING AGENCY NAME(S) AND ADDRESS(ES)		10. SPONSOR/MONITOR'S ACRONYM(S)			
		11. SPONSOR/MONITOR'S REPORT NUMBER(S)			
12. DISTRIBUTION/AVAILABILITY STATEMENT Approved for public release; distribution unlimited					
13. SUPPLEMENTARY NOTES					
14. ABSTRACT					
15. SUBJECT TERMS					
16. SECURITY CLASSIFICATION OF:			17. LIMITATION OF ABSTRACT	18. NUMBER OF PAGES	19a. NAME OF RESPONSIBLE PERSON
a. REPORT unclassified	b. ABSTRACT unclassified	c. THIS PAGE unclassified	Same as Report (SAR)	8	

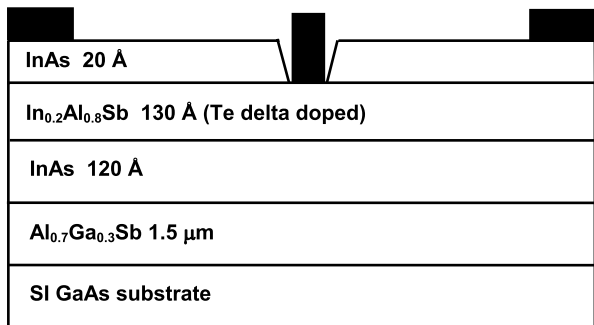

Fig. 1 InAlSb/InAs HEMT layer design.

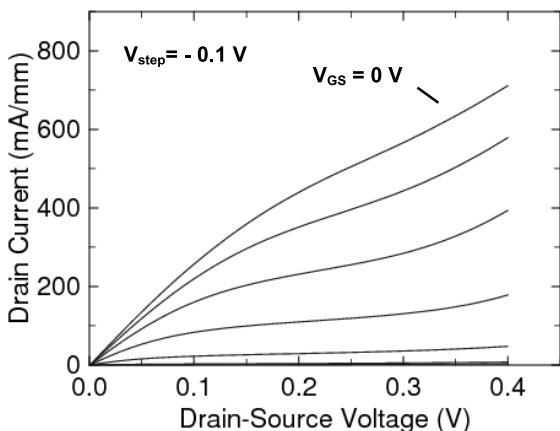

Fig. 2 InAlSb/InAs HEMT drain characteristics. $L_G = 0.2 \mu\text{m}$, $L_{DS} = 0.6 \mu\text{m}$, $W_G = 28 \mu\text{m}$, $V_{GS} = -0.1 \text{ V/step}$.

formed using PMMA e-beam lithography and lift-off techniques. Prior to deposition, the sample was given an O_2 plasma etch, followed by a 15 s etch in a citric-acid-based solution to remove the InAs cap layer. Finally, device isolation was achieved by wet chemical etching. With this etch, a gate air bridge was formed which extends from the channel to the gate bonding pad.

The drain characteristics obtained for a HEMT with a $0.2 \mu\text{m}$ gate length are shown in Fig. 2. The on-resistance at $V_{DS} = 50 \text{ mV}$ is $0.34 \Omega\text{-mm}$ for the $0.6 \mu\text{m}$ source-drain spacing. The maximum transconductance at $V_{DS} = 0.2 \text{ V}$ and 0.3 V is 1.3 S/mm and 1.7 mS/mm , respectively, as shown in Fig. 3. The values are comparable to the highest reported in any FET technology at these drain voltages. From the TLM measurements shown in Fig. 4, the ohmic contact resistance is estimated to be $0.03 \Omega\text{-mm}$. The S-parameters of the HEMTs were measured on-wafer from 1 to 40 GHz. Based on the usual 6 dB/octave extrapolation, an f_T of 135 GHz and an f_{max} of 110 GHz were obtained at $V_{DS} = 0.35 \text{ V}$ and $V_{GS} = -0.25 \text{ V}$. After removal of the gate bonding pad capacitance from an equivalent circuit, an intrinsic f_T of 165 GHz was obtained. This value corresponds to an $f_T L_g$ product of $33 \text{ GHz}\text{-}\mu\text{m}$.

AlSb is well known to oxidize rapidly when exposed to air. The oxidation stability of the InAlSb/InAs HEMTs was investigated to determine the reactivity of the InAlSb

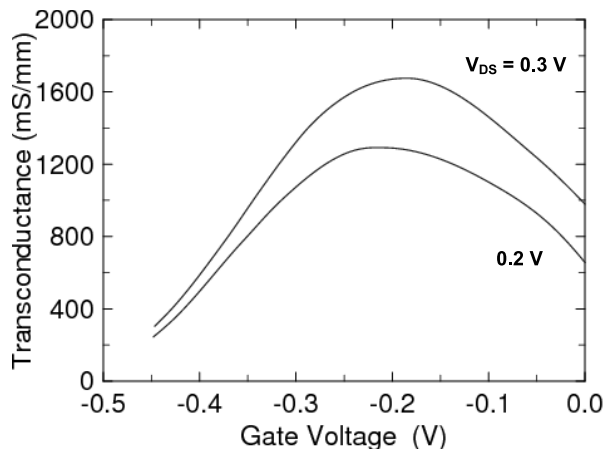

Fig. 3 HEMT transconductance vs. gate voltage.

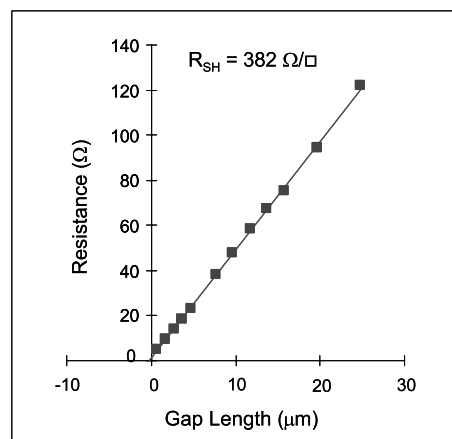

Fig. 4 TLM measurement on InAlSb/InAs HEMT material.

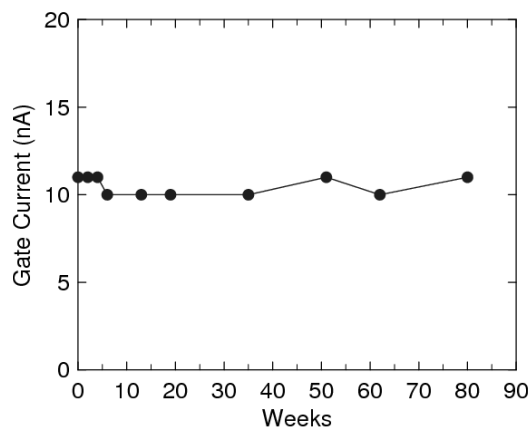

Fig. 5 Gate current stability measurements vs. time.

barrier layer. In this study, the gate current at $V_{DS} = 50 \text{ mV}$ and $V_{GS} = 0 \text{ V}$ on unpassivated HEMTs was monitored as a function of time in air. As shown in Fig. 5, the variation in the gate current after 80 weeks was only 1 nA, indicating the marked improvement in stability when In is added to the AlSb barrier material. Similar measurements of the

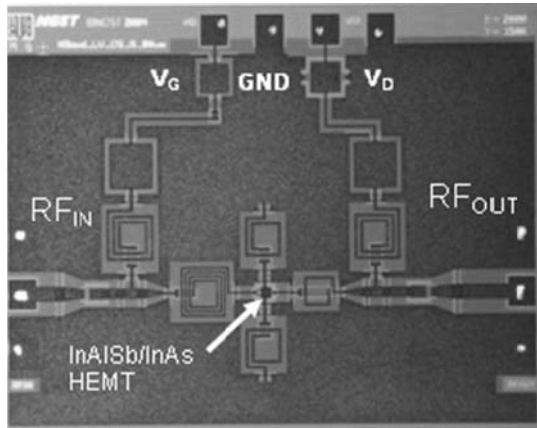

Fig. 6 Photograph of an InAlSb-InAs HEMT LNA.

drain current and gate current near pinch-off also revealed no significant change after 80 weeks.

The first InAlSb/InAs HEMT MMICs have also been recently demonstrated [11]. A photograph of the MMIC is shown in Fig. 6. The $0.1\ \mu\text{m}$ gate-length HEMTs in these MMICs exhibit an f_T of approximately 220 GHz when biased at $V_{DS} = 0.3\ \text{V}$ and $V_{GS} = -0.3\ \text{V}$. This value is comparable to those obtained previously for HEMTs with an InAlAs/AlSb barrier. With only 2 mW power dissipation, the X-band MMICs exhibited an associated gain and noise-figure at 12 GHz of approximately 12 dB and 3 dB, respectively, and an rf yield greater than 80%.

3. InAlSb/InAs HEMTs with an n^+ Cap Layer

The use of n^+ cap layer structures to enable non-alloyed, low resistance ohmic contacts and a reduction in the source-drain access resistance has been effectively utilized in InP-based HEMTs [12]. The use of an n^+ cap layer has also been demonstrated in Sb-based HEMTs with an InAlAs/AlSb upper barrier layer [13]. For Sb-based HEMTs, the InAlAs layer typically employed in the top barrier is in tensile strain with a 5.5% mismatch with the buffer layer [14]. Replacement of this layer with an InAlSb layer which is compressively-strained with a mismatch of only 1.3% would facilitate advanced cap layer designs in Sb-based HEMTs. The benefits of such a replacement are improved quality and reproducibility of the cap and barrier layer material, improved cap layer design flexibility, and a more controllable gate recess etch process, particularly when etching through a thin highly-doped barrier layer is required. In this section, we report on the material growth and device characteristics of the InAlSb/InAs HEMTs with an n^+ cap layer.

A cross section of the material layer design is shown in Fig. 7. A Te delta-doped layer was inserted within the $90\ \text{\AA}$ InAlSb barrier layer, and was located $65\ \text{\AA}$ above the channel. The nominal carrier density of the $200\ \text{\AA}$ thick n^+ InAs(Te) cap layer is $1 \times 10^{19}\ \text{cm}^{-3}$. A wafer map of sheet resistance is shown in Fig. 8. The uniformity is good, with an average value of $79.3\ \Omega/\square$ and a standard deviation

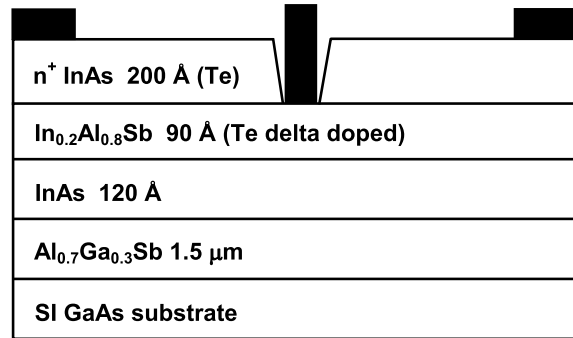

Fig. 7 InAlSb/InAs HEMT material with n^+ cap layer.

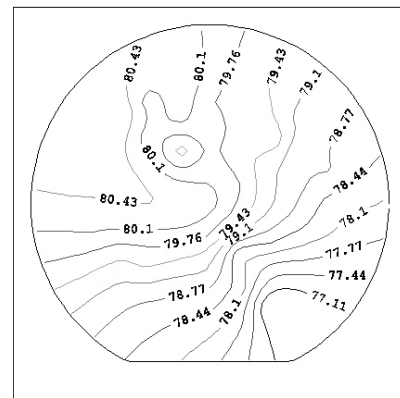

Fig. 8 Sheet resistance (Ω/\square) uniformity of HEMT starting material with n^+ cap layer; wafer diameter is 76 mm.

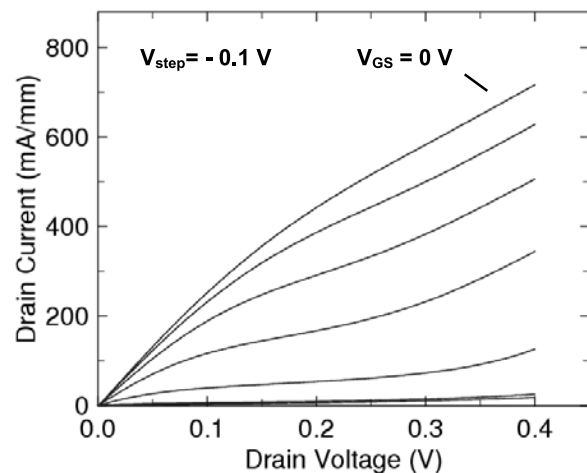

Fig. 9 Drain characteristics of InAlSb/InAs HEMT with n^+ cap layer. $L_G = 0.28\ \mu\text{m}$, $L_{DS} = 1.7\ \mu\text{m}$, $W_G = 28\ \mu\text{m}$, $V_{GS} = -0.1\ \text{V/step}$.

of $0.96\ \Omega/\square$. Hall measurements performed on the starting material indicated a sheet resistance of $89\ \Omega/\square$. Hall measurements were also performed on the starting material after removal of the n^+ cap layer using a selective chemical etch. The sheet carrier density and mobility at 300 K were $2.0 \times 10^{12}\ \text{cm}^{-2}$ and $23,200\ \text{cm}^2/\text{V-s}$, respectively. The rms surface roughness after removal of the n^+ cap layer was $1.9\ \text{nm}$ for a $5 \times 5\ \mu\text{m}^2$ area. Atomic force microscopy mea-

measurements were also performed on the heterostructure surface after a gate recess etch in the resist opening (bi-level PMMA/PMMA-MAA) prior to gate metal definition. In this case, the rms surface roughness after removal of the n⁺ cap layer was 1.6 nm.

The HEMTs were fabricated as previously described except that a recess etch time of 120 seconds was employed to ensure etching through the thicker cap layer. The drain characteristics obtained for a HEMT with a 0.28 μm gate length are shown in Fig. 9. The on-resistance at 50 mV is 0.35 Ω-mm for the 1.7 μm source-drain spacing. The maximum transconductance at V_{DS} = 0.2 V and 0.3 V is 1.3 and 1.75 S/mm, respectively, as shown in Fig. 10. These values are comparable to those obtained in the previous section. From on-resistance measurements as a function of source-drain spacing of HEMTs fabricated on the same wafer, the ohmic contact resistance is estimated to be 0.03 Ω-mm as shown in Fig. 11 [13]. The sheet resistance obtained from this measurement is 126 Ω/□. To illustrate the effect of the n⁺ cap layer, the values obtained for HEMTs with a 20 Å

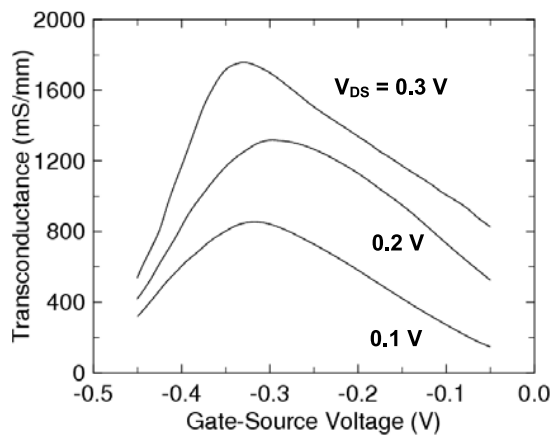

Fig. 10 Transconductance vs. gate voltage of InAlSb/InAs HEMT with n⁺ layer.

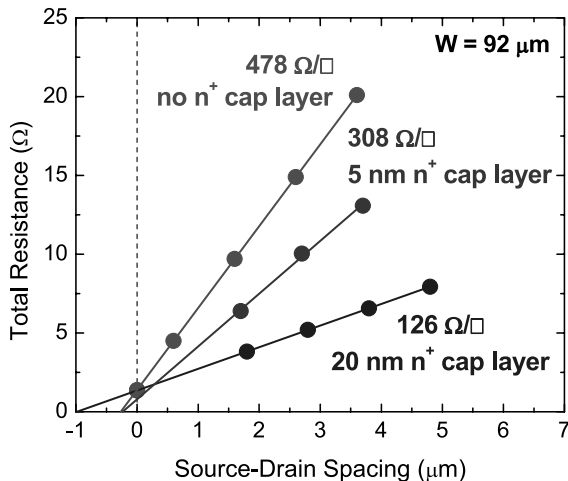

Fig. 11 HEMT on-resistance comparison on material with and without n⁺ cap layers.

undoped cap layer and a 50 Å n⁺ cap layer are also included in Fig. 11. For a 2 μm source-drain spacing, the HEMT on-resistance is reduced by more than a factor of 3. Further reduction in the source-drain resistance can be expected with the implementation of advanced n⁺ cap layer designs.

The S-parameters of the HEMTs were measured on-wafer from 1 to 40 GHz. Based on the usual 6 dB/octave extrapolation, an *f_T* of 80 GHz and an *f_{max}* of 90 GHz were obtained at V_{DS} = 0.3 V and V_{GS} = -0.4 V. After removal of the gate bonding pad capacitance from the equivalent circuit, an intrinsic *f_T* of 90 GHz was obtained, corresponding to an *f_T*-*L_g* product of 25 GHz-μm. HEMTs fabricated from this material with a 0.2 μm gate length exhibited an intrinsic *f_T* of 130 GHz and an *f_{max}* of 120 GHz. Higher *f_T*-*L_g* products can be expected with a shorter source-drain spacing. The *f_{max}* values obtained on the HEMTs with and without the n⁺ cap layer should improve with the implementation of a low-gate-metal-resistance T-gate structure.

4. InAlSb/InGaSb p-Channel HFETs

For p-channel HFETs in complementary circuits, the In_xGa_{1-x}Sb alloy system is attractive since the binary endpoints have the highest bulk hole mobilities of any III-V compound and a significant valence band barrier to enable quantum confinement [15]–[17]. This potential can be enhanced by using compressive strain to produce advantageous band splitting. As work in this direction, in this section we report on the fabrication and improved performance of Sb-based p-channel HFETs with an InAlSb/AlGaSb barrier, a strained, high-mobility, In_{0.41}Ga_{0.59}Sb quantum well channel, and no highly-reactive AlSb material within the structure.

The Sb-based HFET material was grown by MBE on a semi-insulating (100) GaAs substrate. A 1.5 μm undoped Al_{0.8}Ga_{0.2}Sb buffer layer was used to accommodate the 7% lattice mismatch. A cross section of the material layer design is shown in Fig. 12. Details of the growth procedures have been reported elsewhere [18]. The In_{0.41}Ga_{0.59}Sb

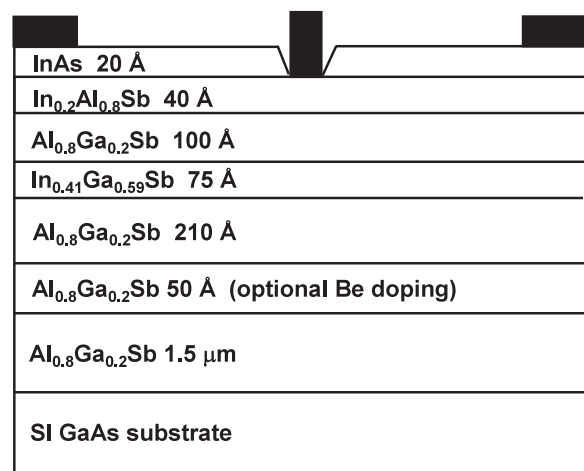

Fig. 12 InAlSb/InGaSb p-channel HFET layer design.

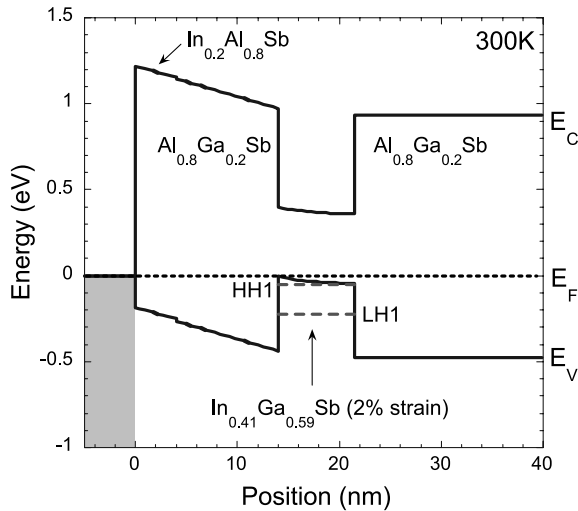

Fig. 13 p-Channel HFET energy-band diagram.

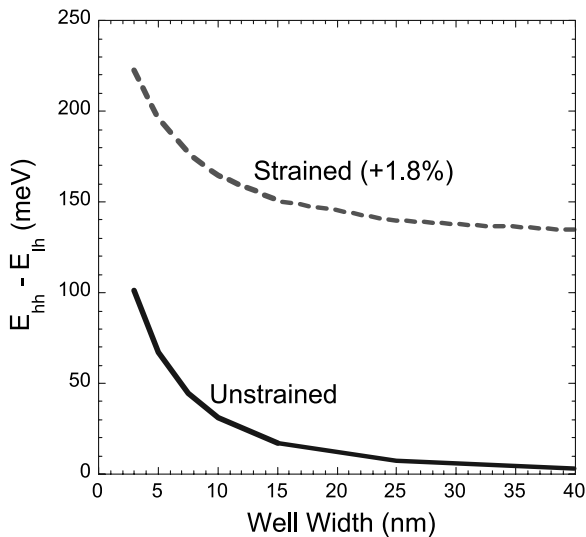

Fig. 14 Heavy hole and light hole energy separation dependence on well width for strained and unstrained conditions.

channel layer is in a state of biaxial compressive strain since it was grown epitaxially on the relaxed AlGaSb buffer layer. The strain is about 2% for this particular composition. Modulation doping below the channel has previously been achieved using a 5 nm Be-doped AlGaSb layer. This optional doping scheme can enhance the capability for future scaling to ultra-thin gate-channel separations. A band diagram of the structure is shown in Fig. 13.

The band diagram and energy levels were obtained using an $8 \times 8 \text{ k} \cdot \text{p}$ method as implemented in the 'nextnano³' program that includes the effects of non-parabolicity, confinement, and strain. The benefits of confinement and strain are in increasing the energy spacing between the heavy and light hole bands, as shown in Fig. 14, and thereby reducing the interband scattering rates. Also beneficial is the strain/confinement-induced decrease in the in-plane mass of the higher lying heavy-hole band. The

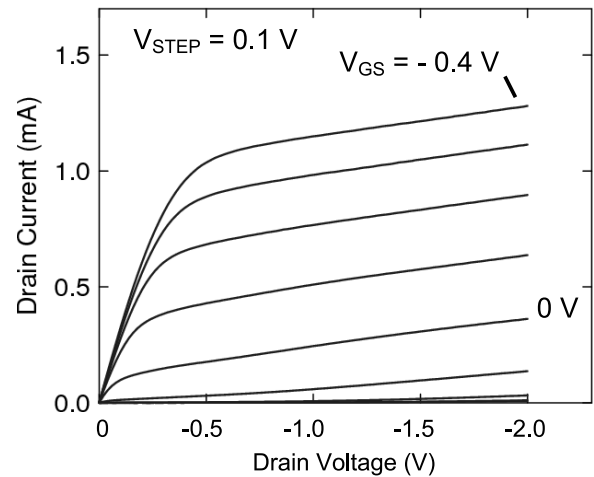

Fig. 15 HFET drain characteristics. $L_G = 0.25 \mu\text{m}$, $L_{DS} = 1.0 \mu\text{m}$, $W_G = 28 \mu\text{m}$, $V_{GS} = 0.1 \text{ V/step}$.

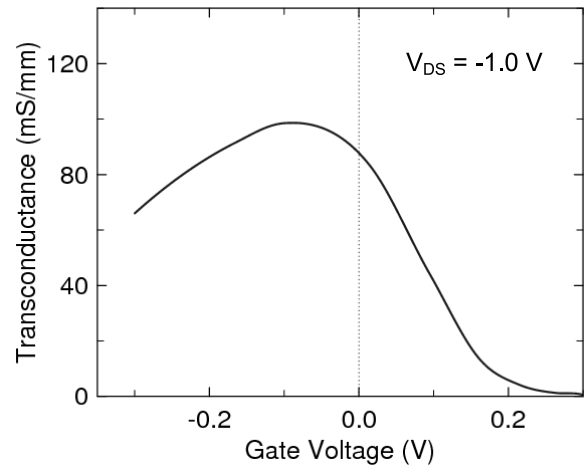

Fig. 16 p-Channel HFET transconductance vs. gate voltage.

$\text{Al}_{0.8}\text{Ga}_{0.2}\text{Sb}/\text{In}_{0.41}\text{Ga}_{0.59}\text{Sb}$ valence band offset is 430 meV. The FET discussed in this paper was not intentionally doped. The room-temperature Hall mobility and sheet carrier concentration of the starting material were $1,500 \text{ cm}^2/\text{V}\cdot\text{s}$ and $6.6 \times 10^{11} \text{ cm}^{-2}$, respectively.

Since the InAlSb/InAs barrier/cap layers were identical to that used for the HEMTs in Sect. 2, the fabrication process was the same as that previously described. The drain characteristics obtained for an HFET with a $0.2 \mu\text{m}$ gate length are shown in Fig. 15. A threshold voltage of 90 mV was measured at $V_{DS} = -1 \text{ V}$. Our simulations indicate enhancement-mode should be obtainable with further design improvements. The low-field source-drain resistance at $V_{GS} = -0.4 \text{ V}$ is $8.1 \Omega\cdot\text{mm}$. The cause for this high value is currently under investigation. The dependence of the transconductance on the gate voltage at $V_{DS} = -1.0 \text{ V}$ is shown in Fig. 16. A maximum transconductance of 100 mS/mm is observed at $V_{GS} = -0.1 \text{ V}$. The gate-source diode I-V characteristic exhibits good rectification and a gate current of 1.5 A/cm^2 at a gate-source bias of 1 V.

The subthreshold slopes at $V_{DS} = -0.05$ V and -1.0 V were 85 mV/dec and 106 mV/dec, respectively. The minimum drain currents observed at $V_{GS} = 0.6$ V for $V_{DS} = -0.05$ V and -1 V were $0.0009 \mu\text{A}/\mu\text{m}$ and $0.04 \mu\text{A}/\mu\text{m}$, respectively. The S-parameters of the HFETs were measured on-wafer from 1 to 40 GHz. Based on the usual 6 dB/octave slope, a maximum f_T of 19 GHz and f_{max} of 34 GHz were obtained. These values are the highest reported for III-V p-channel HFETs. Further improvements in high-speed, low-voltage performance should be possible with future design and process modifications, including a decrease in gate length, a reduction of the contact and access resistances, and implementation of a T-gate structure.

5. Conclusion

The material growth, fabrication, and characterization of Sb-based HEMTs and p-channel HFETs with an InAlSb upper barrier layer have been presented. The Sb-based HEMTs with a $0.2 \mu\text{m}$ gate length exhibit an on-resistance of $0.34 \Omega\text{-mm}$ for the $0.6 \mu\text{m}$ source-drain spacing and a transconductance of 1.3 S/mm at only $V_{DS} = 0.2$ V. An intrinsic f_T of 165 GHz is obtained after removal of the gate bonding pad capacitance from an equivalent circuit, corresponding to an $f_T L_g$ product of $33 \text{ GHz}\cdot\mu\text{m}$. The first HEMT MMICs have been demonstrated with excellent performance and high yield. Oxidation stability measurements on un-passivated devices performed over the course of 80 weeks indicate that the InAlSb barrier is very stable in air. InAlSb/InAs HEMTs with an n^+ cap layer have also been demonstrated. As a result, a low on-resistance of $0.35 \Omega\text{-mm}$ has been observed for a $1.7 \mu\text{m}$ source-drain spacing. The $0.28 \mu\text{m}$ gate length devices exhibited a maximum transconductance at $V_{DS} = 0.2$ V of 1.3 S/mm and an intrinsic $f_T L_g$ product of $26 \text{ GHz}\cdot\mu\text{m}$. Finally, InAlSb/InGaSb p-channel HFETs with a room temperature mobility of $1500 \text{ cm}^2/\text{V}\cdot\text{sec}$ have been demonstrated. At $V_{DS} = -1.0$ V, a maximum transconductance of 100 mS/mm is observed. The $0.2 \mu\text{m}$ gate length devices exhibit a maximum f_T and f_{max} of 19 GHz and 34 GHz, respectively. Continued improvements in the material growth, design, and fabrication of these devices will make them attractive candidates in future analog, digital, and mixed-signal applications where high speed and low power consumption will be required.

Acknowledgment

The authors thank Dr. Mark Rosker at the Defense Advanced Research Projects Agency (DARPA) for his support. This work was also supported by the Office of Naval Research.

References

[1] B.R. Bennett, R. Magno, J.B. Boos, W. Kruppa, and M.G. Ancona, "Antimonide-based compound semiconductors for electronic devices: A review," *Sol. St. Electr.*, vol.49, no.12, pp.1875–1895, Dec. 2005.

[2] W.R. Deal, R. Tsai, M.D. Lange, J.B. Boos, B.R. Bennett, and A. Gutierrez, "A w-band InAs/AlSb low-noise/low-power amplifier," *IEEE Microw. Wireless Compon. Lett.*, vol.15, no.4, pp.208–210, April 2005.

[3] B.Y. Ma, J. Bergman, P. Chen, J.B. Hacker, G. Sullivan, G. Nagy, and B. Brar, "InAs/AlSb HEMT and its application to ultra-low-power wideband high-gain low-noise amplifiers," *IEEE Trans. Microw. Theory Tech.*, vol.54, no.12, pp.4448–4455, Dec. 2006.

[4] W. Kruppa, J.B. Boos, B.R. Bennett, N.A. Papanicolaou, D. Park, and R. Bass, "InAs HEMT narrowband amplifier with ultra-low power dissipation," *Electron. Lett.*, vol.42, no.12, pp.688–690, June 2006.

[5] B.D. Weaver, J.B. Boos, N.A. Papanicolaou, B.R. Bennett, D. Park, and R. Bass, "High radiation tolerance of InAs/AlSb high electron mobility transistors," *Appl. Phys. Lett.*, vol.87, no.17, 173501, Oct. 2005.

[6] R. Chau, S. Datta, M. Doczy, B. Doyle, B. Jin, J. Kavalieros, A. Majumdar, M. Metz, and M. Radosavljevic, "Benchmarking nanotechnology for high-performance and low-power logic transistor applications," *IEEE Trans. Nanotechnology*, vol.4, no.22, pp.153–158, March 2005.

[7] D.-H. Kim, J.A. del Alamo, J.-H. Lee, and K.-S. Seo, "Logic suitability of 50-nm $\text{In}_{0.7}\text{Ga}_{0.3}\text{As}$ HEMTs for beyond-CMOS applications," *IEEE Trans. Electron Devices*, vol.54, no.10, pp.2606–2613, Oct. 2007.

[8] N.A. Papanicolaou, B.R. Bennett, J.B. Boos, D. Park, and R. Bass, "Sb-based HEMTs with a InAlSb/InAs heterojunction," *Electron. Lett.*, vol.41, no.19, pp.1088–1089, Sept. 2005.

[9] B.R. Bennett, B.P. Tinkham, J.B. Boos, M.D. Lange, and R. Tsai, "Materials growth for InAs high electron mobility transistors and circuits," *J. Vac. Sci. Technol. B*, vol.22, no.2, pp.688–694, March 2004.

[10] B.R. Bennett, J.B. Boos, M.G. Ancona, N.A. Papanicolaou, G.A. Cooke, and H. Kheyrandish, "InAlSb/InAs/AlGaSb quantum well heterostructures for high-electron-mobility transistors," *J. Electronic Materials*, vol.36, no.2, pp.99–104, Feb. 2007.

[11] Y.C. Chou, M.D. Lange, J.B. Boos, B.R. Bennett, J.M. Yang, C.H. Lin, L.J. Lee, P.S. Nam, A.L. Gutierrez, R. Tsai, M. Barsky, T.P. Chin, M. Wojtowicz, and A. Oki, "0.1 μm $\text{In}_{0.2}\text{Al}_{0.8}\text{Sb-InAs}$ HEMT low noise amplifiers for ultra-low power applications," *Int. Electron Devices Meeting Tech. Dig.*, Washington, DC, Dec. 2007.

[12] K. Chen, T. Enoki, K. Maezawa, K. Arai, and M. Yamamoto, "High performance InP-based enhancement-mode HEMT's using non-alloyed ohmic contacts and Pt-based buried-gate technologies," *IEEE Trans. Electron Devices*, vol.43, no.2, pp.252–257, Feb. 1996.

[13] C. Kadow, M. Dahlstroem, J.-U. Bae, H.-K. Lin, A.C. Gossard, M.J.W. Rodwell, B. Brar, G.J. Sullivan, G. Nagy, and J.I. Bergman, " n^+ -InAs-InAlAs recess gate technology for InAs-channel millimeter-wave HFETs," *IEEE Trans. Electron Devices*, vol.52, no.2, pp.151–157, Feb. 2005.

[14] J.B. Boos, W. Kruppa, B.R. Bennett, D. Park, S.W. Kirchoefer, R. Bass, and H.B. Dietrich, "AlSb/InAs HEMT's for low-voltage, high-speed applications," *IEEE Trans. Electron Devices*, vol.45, no.9, pp.1869–1875, Sept. 1998.

[15] L.F. Luo, K.F. Longenbach, and W.I. Wang, "p-channel modulation-doped field-effect transistors based on $\text{AlSb}_{0.9}\text{As}_{0.1}/\text{GaSb}$," *IEEE Electron Devices Lett.*, vol.11, no.12, pp.567–569, Dec. 1990.

[16] J.F. Klem, J.A. Lott, J.E. Schirber, S.R. Kurtz, and S.Y. Lin, "Strained quantum well modulation-doped InGaSb/AlGaSb structures grown by molecular beam epitaxy," *J. Electron. Mater.*, vol.22, no.3, pp.315–318, March 1993.

[17] J.B. Boos, B.R. Bennett, N.A. Papanicolaou, M.G. Ancona, J.G. Champlain, R. Bass, and B.V. Shanabrook, "High mobility p-channel HFETs using strained Sb-based materials," *Electron. Lett.*, vol.43, no.15, pp.834–835, July 2007.

[18] B.R. Bennett, M.G. Ancona, J.B. Boos, and B.V. Shanabrook, "Mobility enhancement in strained p-InGaSb quantum wells," *Appl.*

Phys. Lett., vol.91, no.4, 042104, July 2007.



J. Brad Boos received the B.S. degree in chemistry from the University of Maryland, College Park, in 1977, and the M.S. degree in electrical engineering from The George Washington University, Washington, DC, in 1987. In 1980, he joined the research staff in the Electronics Science and Technology Division, Naval Research Laboratory, Washington, DC, where he worked on III-V microwave and mm-wave device development. In 2002, he was made head of the High-Speed, Low-Power Devices Section.

His research efforts have included the design, fabrication, and characterization of InP JFET's, InP-based HEMT's and photodetectors, and Sb-based HEMT's, p-channel HFET's, HBT's, and quantum devices. Mr. Boos has served on the Technical Program Committee and Steering Committee of the InP and Related Materials Conference and served as Program Chair for the 2000 IPRM Conference. He has also served on the Technical Program Committee of the International Semiconductor Device Research Symposium.



Brian R. Bennett received the B.S. and M.S. degrees in geophysics from the Massachusetts Institute of Technology. He then served as a military officer in the Air Force's Solid State Sciences Division from 1984 to 1988. His research included electro-optic effects in Si and group III-V semiconductors and low-temperature deposition of silicon dioxide. In 1992, he received the Ph.D. degree in Materials Science and Engineering from M.I.T. Since 1992, Dr. Bennett has been at the Naval Research Laboratory in Washington, DC. His current research focuses on the epitaxial growth and applications of antimonide and arsenide semiconductor heterostructures, including n-channel InAs high-electron-mobility transistors and p-channel InGaSb field-effect transistors. He serves on the Electronic Materials Committee and is a member of the American Physical Society.



Nicolas A. Papanicolaou

He received his B.S. degree in Physics in 1971, his M.S. and Ph.D. in Electrical Engineering in 1973 and 1978 respectively, all from the University of Maryland at College Park. From 1978 to 1981, he was a scientist at the Martin Marietta Laboratories (presently Lockheed-Martin) where he conducted research on Schottky-barrier mixers and IMPATT diode development for millimeter wave circuits and systems. Since 1981, he has been with the Naval

Research Laboratory where he was involved in the research and development of mixers, IMPATTs and MESFETs for microwave applications. He has also carried out research in the area of refractory metallization systems for high temperature semiconductor device applications on materials such as GaAs, SiC and GaN. Presently he is involved with research in the development of antimonide-based high electron mobility transistors (HEMTs) for low voltage, high-speed applications, as well as the investigation of micro-electro-mechanical systems (MEMs) for optical and microwave switching applications.

Mario G. Ancona is a research physicist in the Electronics Science and Technology Division at the Naval Research Laboratory in Washington, DC and a part-time faculty member in the Applied Physics Program at the Johns Hopkins University. His research interests are in semiconductor device modeling and simulation and in nanoelectronics. (Photo not available at time of printing)



James G. Champlain received the B.S. degree in Electrical Engineering from Virginia Polytechnic Institute and State University in 1995 and the M.S. and Ph.D. degrees in Electrical Engineering, specializing in Solid State Devices and Physics, from the University of California, Santa Barbara, CA in 1996 and 2002, respectively. From 2002 to 2004, he worked as an Assistant Research Engineer at UCSB in the Electrical Engineering Department on heterojunction bipolar transistors in the InP and GaN

material systems. Since 2004, James Champlain has been at the Naval Research Laboratory. His current research is on Sb-based electronic devices, specifically devices for high-speed, low-power applications, such as Sb-based HBTs, pn diodes, and HBVs.



Yeong-Chang Chou received his B.S. and M.S. degrees in electrical engineering from National Cheng Kung University, Tainan, Taiwan, in 1981 and 1983, respectively. He received the Ph.D. degree in electrical engineering and computer science from the University of California, Irvine, in 1997. He joined the Cheng-Shan Institute of Science and Technology, Taiwan, from 1983 to 1990. From 1990 to 1993, he joined Electro-Optek Corporation, Torrance, CA. He joined the Advanced Microelectronics Laboratory,

TRW, Inc., Redondo Beach, CA in 1996 as a member of the technical staff, where he was deeply involved in the investigation of reliability aspects of GaAs-based and InP-based HEMT devices and MMICs technologies for commercial, military, and space applications. Since 2002, he has been responsible for the development of process techniques for the improvement of reliability performance in GaAs-based and InP-based HEMT technologies. At TRW, he has also served a Subproject Manager for the programs of PLO, MLS, CloudSat, Mantech, Herschel HIFI, and Crosslink responsible for the quality assurance of high RF performance GaAs pHEMT and InP HEMT MMICs for military/space applications. He has authored and co-authored more than 80 papers in the journals and conferences in the areas of GaAs, InP, GaN-based, and AlSb/InAs HEMT devices and MMICs. He is currently a senior HEMT product engineer at Northrop Grumman Space Technology (NGST), Redondo Beach, CA. At NGST, he has been involved in the technology development of high reliability assurance on 4-inch GaAs and InP-based HEMT MMICs for commercial, military, and space applications. Since 2006, he has been responsible for the development of AlSb/InAs HEMTs with high manufacturability and reliability for ultra-low power applications.



Michael D. Lange [REDACTED] He completed his formal education in 1993 with a Ph.D. in physics from The University of Illinois at Chicago, where he majored in solid state physics and researched growth by molecular-beam epitaxy (MBE) of certain compound semiconductor materials. Since commencing his university MBE research in 1986, he has worked continuously in the field of compound-semiconductor MBE.

In his present position as a Staff Engineer at Northrop Grumman Space Technology in Redondo Beach, California, he conducts the MBE portion of development projects on various III-V compound semiconductor materials structures for millimeter-wave transistors. His work focuses chiefly on high-electron-mobility transistors designed with indium arsenide in the channel, pseudomorphically strained either to aluminum gallium antimonide or indium phosphide, and including certain other nearly-lattice-matched compound semiconductor materials.

Jeffrey M. Yang (Biography and photo are not available at time of printing)



Robert Bass received the B.S. degree in physics from Drexel Institute of Technology Philadelphia, PA, in 1966 and the M.S. and Ph.D. degrees in physics from Michigan State University, East Lansing, in 1968 and 1972, respectively. During the next 17 years he pursued a career in the teaching profession. In 1989 he joined the Nanoelectronics Processing Facility at the Naval Research Laboratory, Washington, DC as a research physicist in the area of electron beam lithography. He has been a Principle Investigator for DARPA's Advanced Lithography Program and has provided lithographic expertise to university and other government agencies requiring nano-lithography. He is currently providing electron beam lithography support and process development for various projects at NRL including III-V HEMT development, chemical, and biological sensors.

investigator for DARPA's Advanced Lithography Program and has provided lithographic expertise to university and other government agencies requiring nano-lithography. He is currently providing electron beam lithography support and process development for various projects at NRL including III-V HEMT development, chemical, and biological sensors.

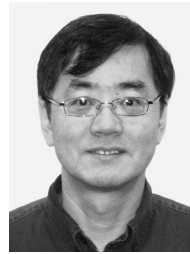

Doewon Park received the B.S. and M.S. degrees in Electrical Engineering from the University of Maryland, College Park, MD in 1983 and 1986, respectively. In 1985, he joined the Naval Research Laboratory as an Electronics Engineer where he is engaged in the development of HEMT and Nanostructure devices. His current research interests include nanoelectronic device design and fabrication.



Ben V. Shanabrook received his Ph.D. in physics from the Pennsylvania State University in 1981. He is the Superintendent of the Electronics Science and Technology Division of the Naval Research Laboratory and is responsible for the technical and administrative management of a broad spectrum of basic and applied research programs involving in-house experimental and theoretical research at the frontiers of electron device technology. Basic research is performed on electronic materials, surface physics, nanoscience and materials growth with the goal of developing a fundamental understanding that enables better performance of current electronic devices as well as the creation of disruptive technologies. When appropriate, the results of this basic research are transitioned into the applied research areas that aim to redefine the "state of the art" in electronics technology. This includes electromagnetic wave generation and detection from 10–1000 GHz based on both solid state and vacuum electronic devices and the creation of power electronic devices that operate at voltages as high as 30 kV with megawatts of power control. Dr. Shanabrook has over 200 technical publications with more than 4000 citations, three patents and co-authored four chapters in books. He is a fellow of the American Physical Society and has served as a member of the program committee of the Electronic Materials Conference and the Physics and Chemistry of Semiconductor Interfaces Conference. In addition he is a member of the Board of Advisory Editors of *Physica E - Low Dimensional Systems and Nanostructures*.

surface physics, nanoscience and materials growth with the goal of developing a fundamental understanding that enables better performance of current electronic devices as well as the creation of disruptive technologies. When appropriate, the results of this basic research are transitioned into the applied research areas that aim to redefine the "state of the art" in electronics technology. This includes electromagnetic wave generation and detection from 10–1000 GHz based on both solid state and vacuum electronic devices and the creation of power electronic devices that operate at voltages as high as 30 kV with megawatts of power control. Dr. Shanabrook has over 200 technical publications with more than 4000 citations, three patents and co-authored four chapters in books. He is a fellow of the American Physical Society and has served as a member of the program committee of the Electronic Materials Conference and the Physics and Chemistry of Semiconductor Interfaces Conference. In addition he is a member of the Board of Advisory Editors of *Physica E - Low Dimensional Systems and Nanostructures*.