

Functionally Graded Multifunctional Hybrid Composites for Extreme Environments

Ozden O. Ochoa

Department of Mechanical Engineering

Texas A&M University

HTAM Program Review Arlington VA

February 1, 2010



AFOSR-MURI
Functionally Graded Hybrid Composites



Report Documentation Page

Form Approved
OMB No. 0704-0188

Public reporting burden for the collection of information is estimated to average 1 hour per response, including the time for reviewing instructions, searching existing data sources, gathering and maintaining the data needed, and completing and reviewing the collection of information. Send comments regarding this burden estimate or any other aspect of this collection of information, including suggestions for reducing this burden, to Washington Headquarters Services, Directorate for Information Operations and Reports, 1215 Jefferson Davis Highway, Suite 1204, Arlington VA 22202-4302. Respondents should be aware that notwithstanding any other provision of law, no person shall be subject to a penalty for failing to comply with a collection of information if it does not display a currently valid OMB control number.

1. REPORT DATE 01 FEB 2010		2. REPORT TYPE		3. DATES COVERED 00-00-2010 to 00-00-2010	
4. TITLE AND SUBTITLE Functionally Graded Multifunctional Hybrid Composites for Extreme Environments				5a. CONTRACT NUMBER	
				5b. GRANT NUMBER	
				5c. PROGRAM ELEMENT NUMBER	
6. AUTHOR(S)				5d. PROJECT NUMBER	
				5e. TASK NUMBER	
				5f. WORK UNIT NUMBER	
7. PERFORMING ORGANIZATION NAME(S) AND ADDRESS(ES) Texas A&M University, Department of Mechanical Engineering, College Station, TX, 77843				8. PERFORMING ORGANIZATION REPORT NUMBER	
9. SPONSORING/MONITORING AGENCY NAME(S) AND ADDRESS(ES)				10. SPONSOR/MONITOR'S ACRONYM(S)	
				11. SPONSOR/MONITOR'S REPORT NUMBER(S)	
12. DISTRIBUTION/AVAILABILITY STATEMENT Approved for public release; distribution unlimited					
13. SUPPLEMENTARY NOTES AFOSR High Temperature Aerospace Materials Contractors Meeting, Feb 1-5, 2010, Arlington, VA. U.S. Government or Federal Rights License					
14. ABSTRACT					
15. SUBJECT TERMS					
16. SECURITY CLASSIFICATION OF:			17. LIMITATION OF ABSTRACT Same as Report (SAR)	18. NUMBER OF PAGES 60	19a. NAME OF RESPONSIBLE PERSON
a. REPORT unclassified	b. ABSTRACT unclassified	c. THIS PAGE unclassified			

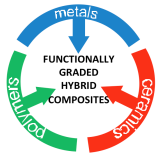

Synthesis, Characterization and Prognostic Modeling of Functionally Graded Hybrid Composites for Extreme Environments

Principal Investigator

Dimitris C. Lagoudas

Department of Aerospace Engineering

Texas A&M University

College Station, TX 77843

Partner Universities

Texas A&M University

University of Illinois at Urbana-Champaign

Virginia Polytechnic Institute and State University

Stanford University

University of Dayton Research Institute



AFOSR-MURI
Functionally Graded Hybrid Composites



2



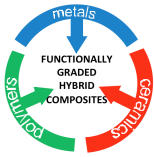

Research Team

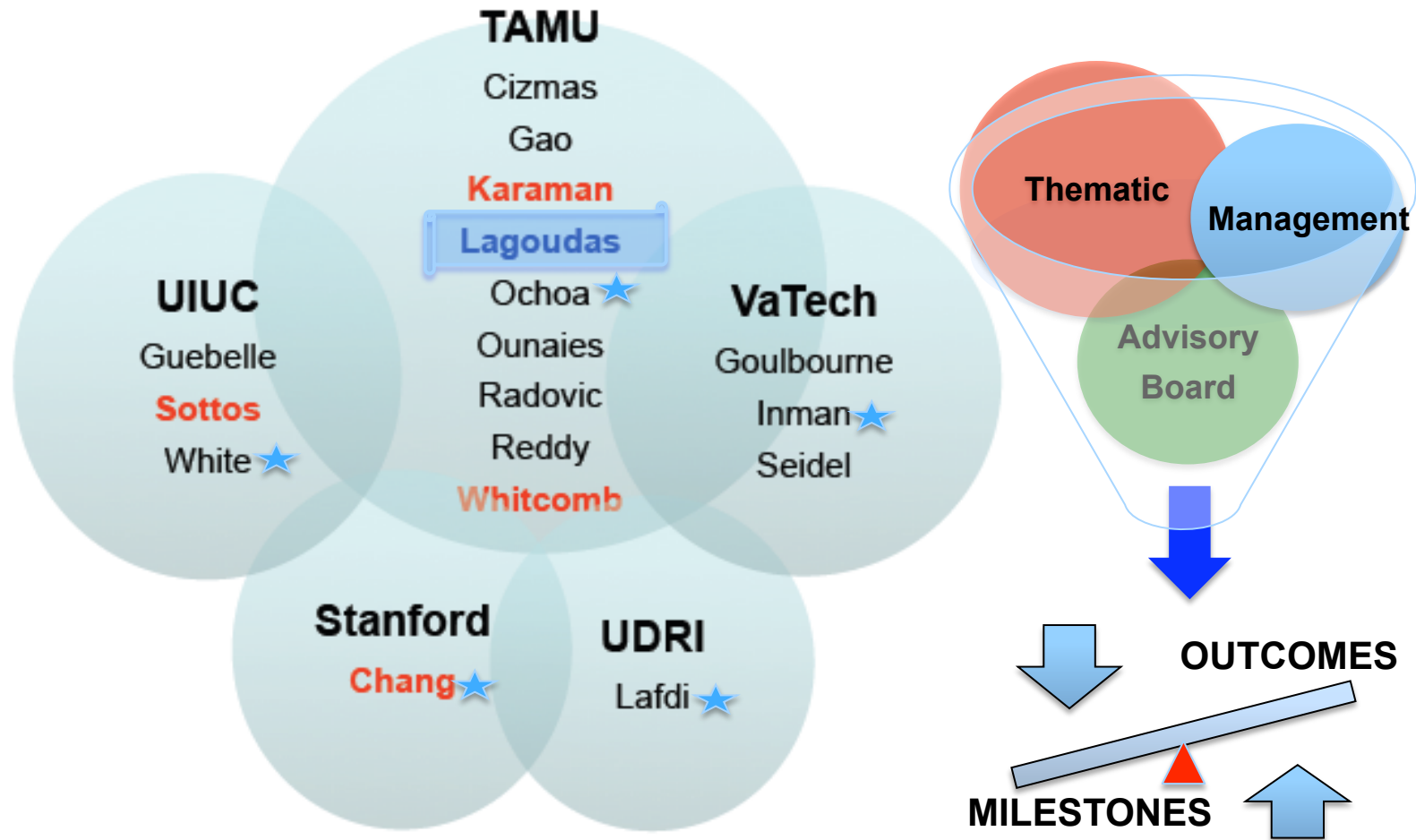

AFOSR-MURI
Functionally Graded Hybrid Composites



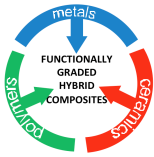

Goals

A comprehensive research program coupling **thermal-acoustic-mechanical flight loads** to guide the design of multi-functional **Functionally Graded Hybrid Composite (FGHC)** systems with **integrated sensing capabilities** for extreme environments.

- multi-scale simulations
- multi-scale characterization

Target operating environment: 250 °C - 1000 °C, with a durability envelope of 1000 hours exposure at 550 °C and 300 thermal cycles



AFOSR-MURI
Functionally Graded Hybrid Composites



4



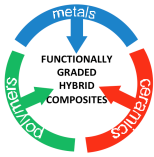

Research Thrusts

Development and Fabrication Develop multifunctional FGHC with multiple layers: a ceramic thermal barrier layer, a graded ceramic/metal composite (GCMcC) layer and a high-temperature polymer matrix composite (PMC) layer.

Multi-scale Characterization Develop and apply experimental techniques to obtain mechanical and physical properties of GCMcC and PMC layers and of the hybrid interfaces.

Insitu NDE/SHM Integrate of SHM capabilities through networked sensor/actuator arrays, diagnostic algorithm development, control theory and fabrication optimization.

Multi-scale Modeling Develop of novel material systems for use in extreme environments: design FGHC microstructure, develop experiments and interpret data to obtain basic material properties.



AFOSR-MURI
Functionally Graded Hybrid Composites



5



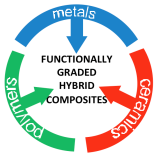

Fundamentals of FGHC

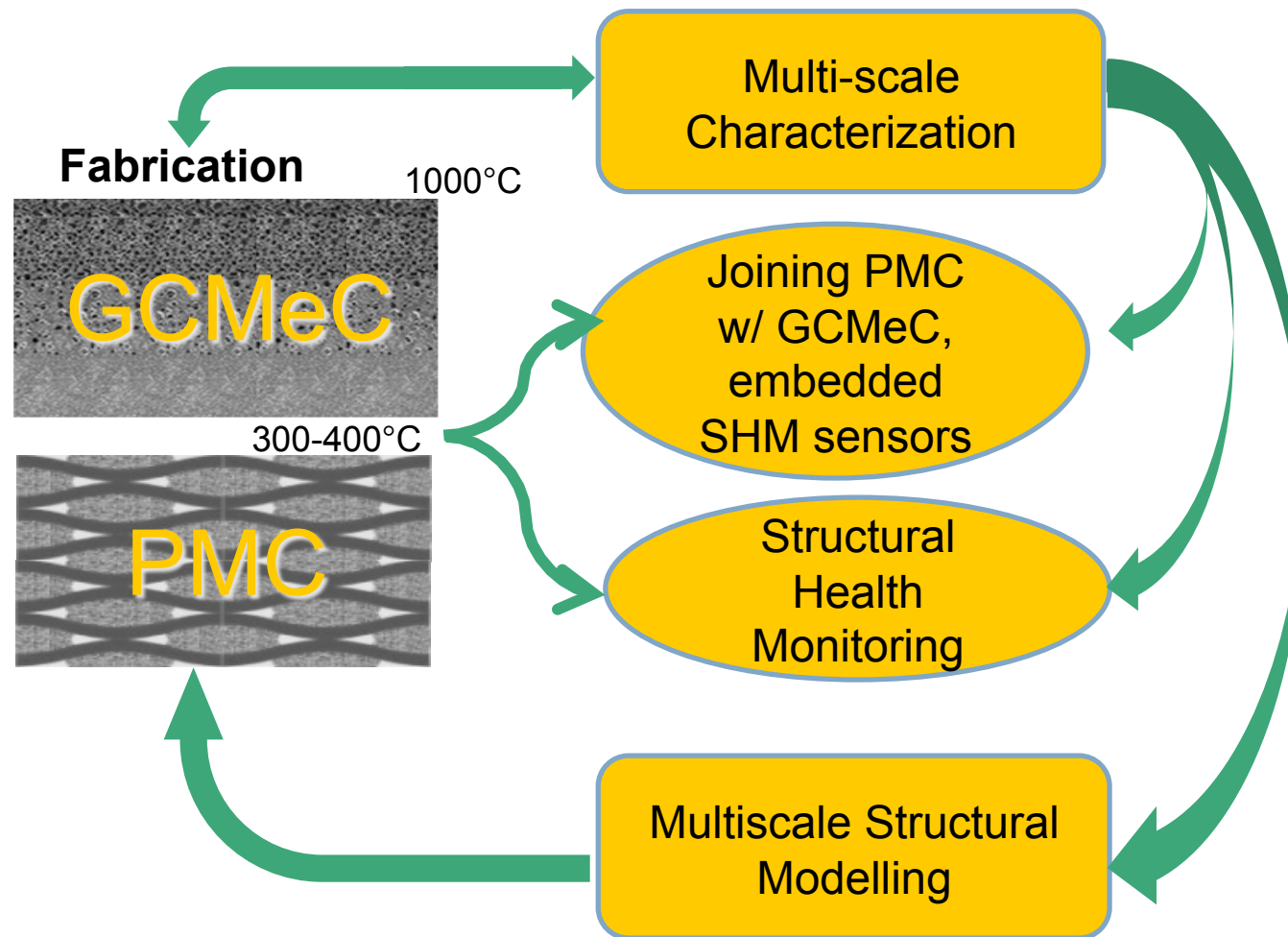

- Initial material parameters
- Validation experiments



AFOSR-MURI
Functionally Graded Hybrid Composites



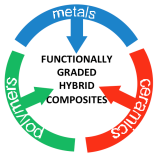

FGHC Fabrication Team

Graded Ceramic Metal Composites (GCMcC)

Radovic (TAMU)
Karaman (TAMU)

Polymer Matrix Composites (PMC)

Actively Cooled
PMC
White (UIUC)

High
Temperature
PMC
Ounaies (TAMU)

Joining GCMcC to PMC

TAMU: Ounaies, Radovic, Karaman
Lafdi (UDRI)

Embedding SHM Modules & Networks

Ounaies (TAMU), Inman (VTU), Chang (Stanford)



AFOSR-MURI
Functionally Graded Hybrid Composites



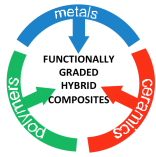

Fabrication and Characterization of Bulk Ceramic MAX Phase and MAX–Metal Composites



AFOSR-MURI
Functionally Graded Hybrid Composites



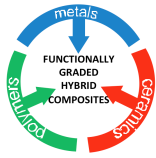

Key Technical Challenges

- Control phase fractions and distribution including gradual change in phase distribution through the thickness;
- Control over phase distribution using different processing approaches:
 - Infiltration
 - Reactive sintering
 - Co-sintering
- Interfacial integrity between metal-ceramic particles and layers
 - Both candidate alloys and ceramics have Ti.
- Long term chemical compatibility between metal and ceramic phases, and between layers with different amount of phases;
- Full infiltration of molten metal into porous MAX phase preform.



AFOSR-MURI
Functionally Graded Hybrid Composites



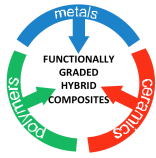

Physical Properties of MAX Phases

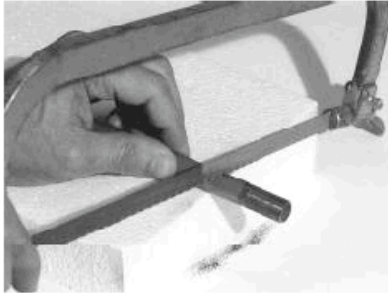

Ti_2AlC block after hammer blows

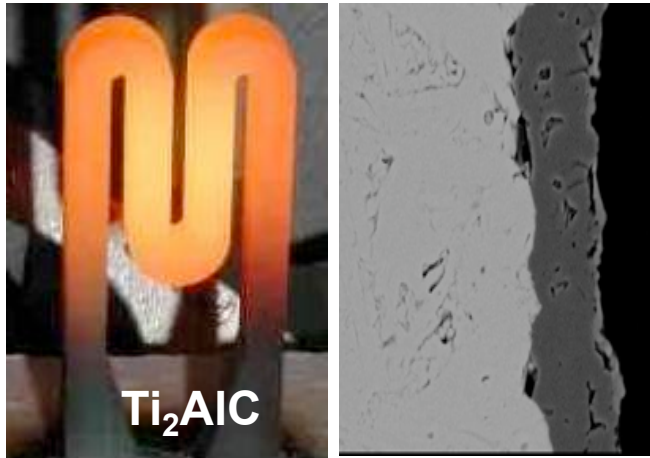

Cycling from room temperature to 1350°C for 8000 times forms only a few micron thick self-healing oxide layer

- Easy to form and machine
- Stiff (320 Gpa) and tough
- Good thermal and electrical conductor
- Thermal shock and Fatigue resistant.
- Damage tolerant.
- Oxidation resistant (in air up to 1400 C).
- Low friction
- Thermally sprayable on metals for corrosion and oxidation protection.

1. Barsoum and El-Raghy, American Scientist, 2001
2. www.3one2.com



AFOSR-MURI
Functionally Graded Hybrid Composites



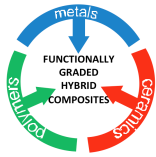

XRD Ti_2AlC Powder

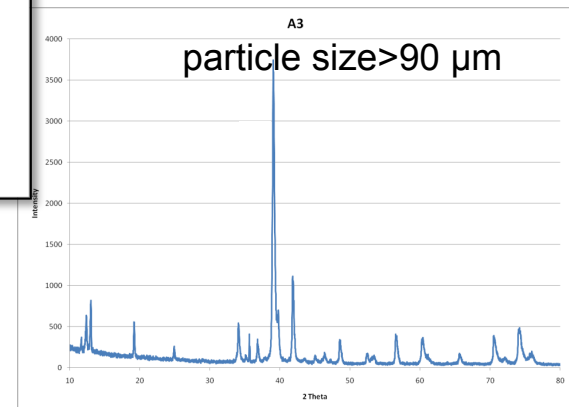
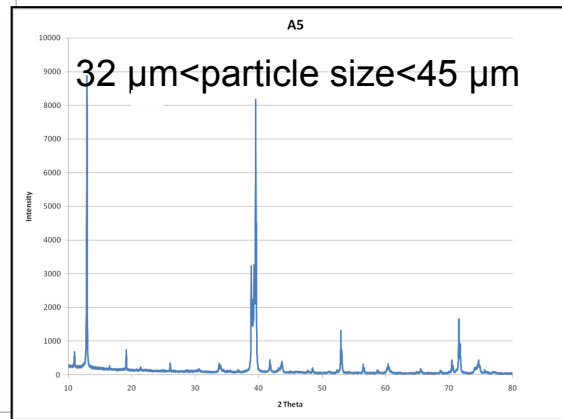
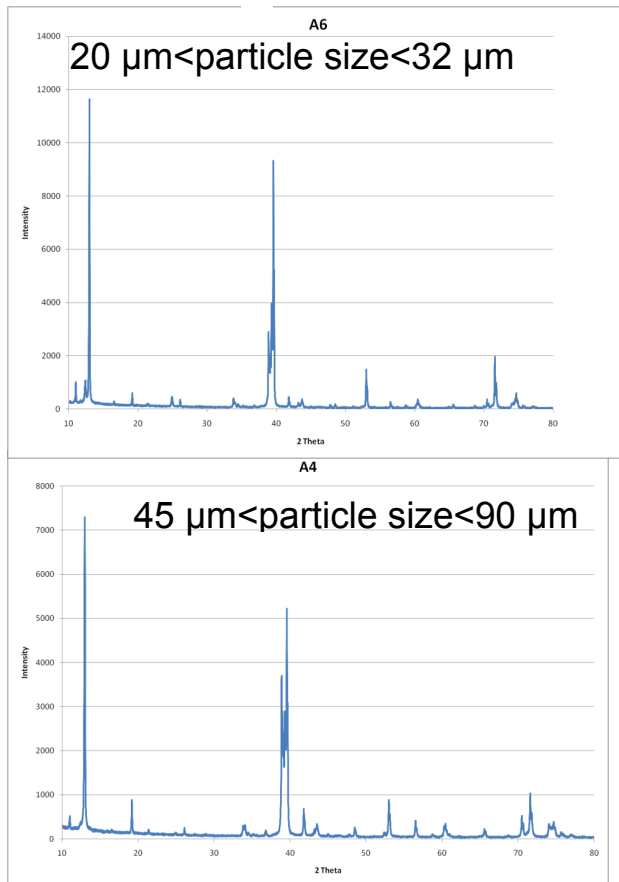

MAXTHAL™ Ti_2AlC powder from 3-one-2 LLC had very small amount of Ti_3AlC_2 , which is also a MAX phase with similar physical properties. Ti_3AlC_2 content increases with increasing particle size and is not detrimental to sintering.



AFOSR-MURI
Functionally Graded Hybrid Composites



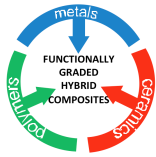

Sintering of Ti_2AlC Ceramics

Porosity of Ti_2AlC samples after sintering at $1400^{\circ}C$ for 4 hrs Under 96% H_2 , 4%Ar

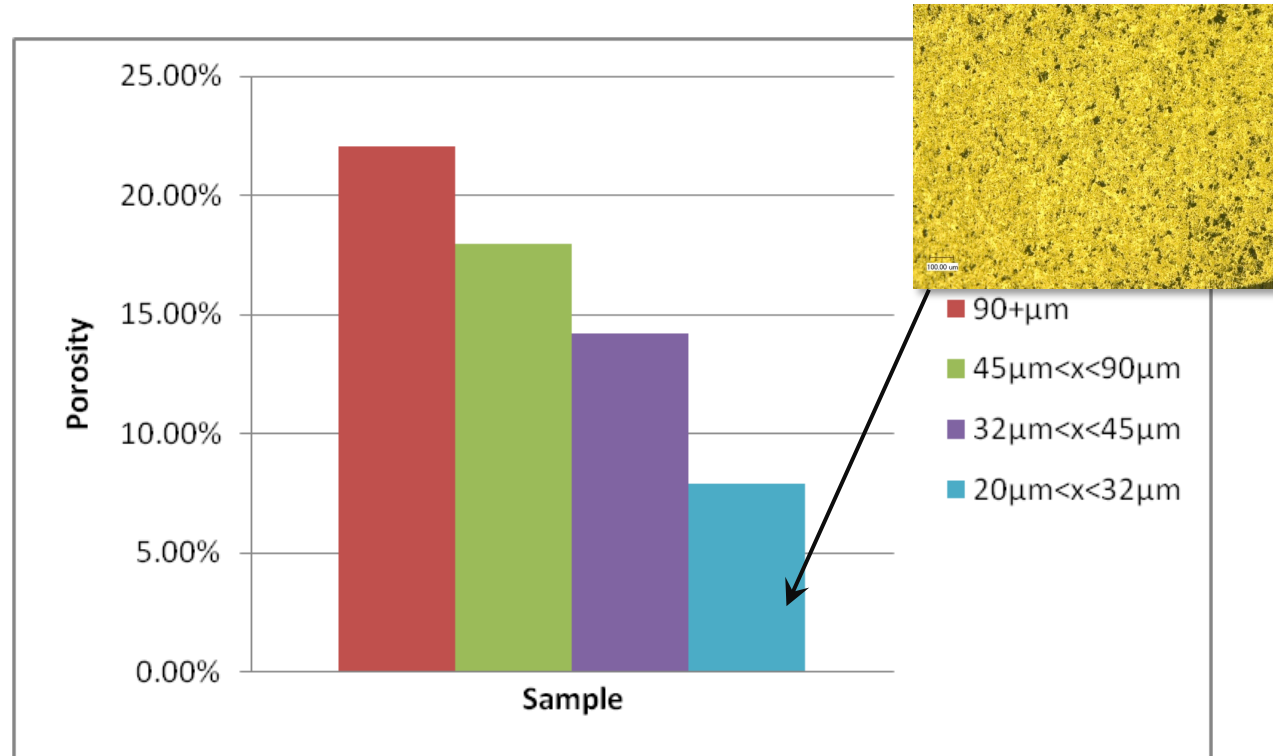
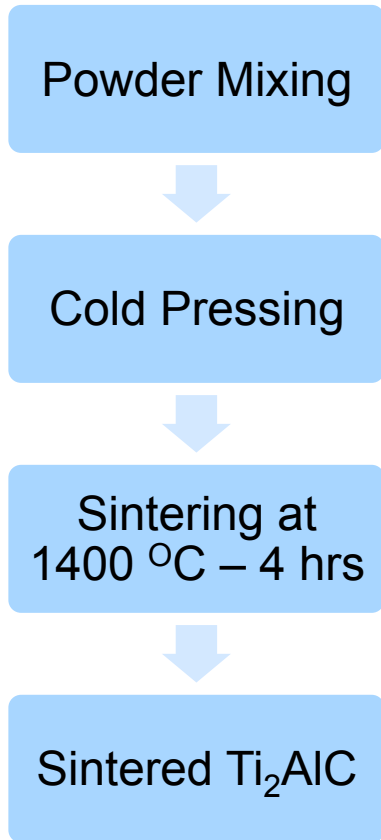

porosity due to pressure-less sintering



AFOSR-MURI
Functionally Graded Hybrid Composites



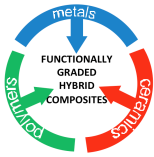

Oxidation of Ti_2AlC Ceramics

oxidation kinetics of the self-healing protective oxide on ceramic

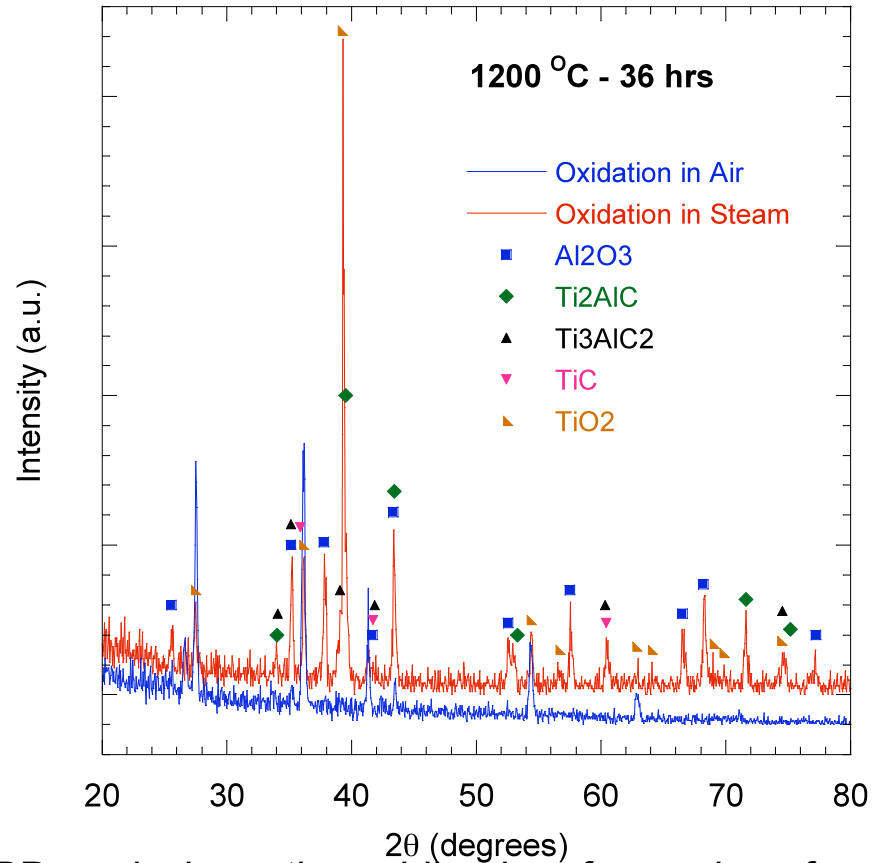
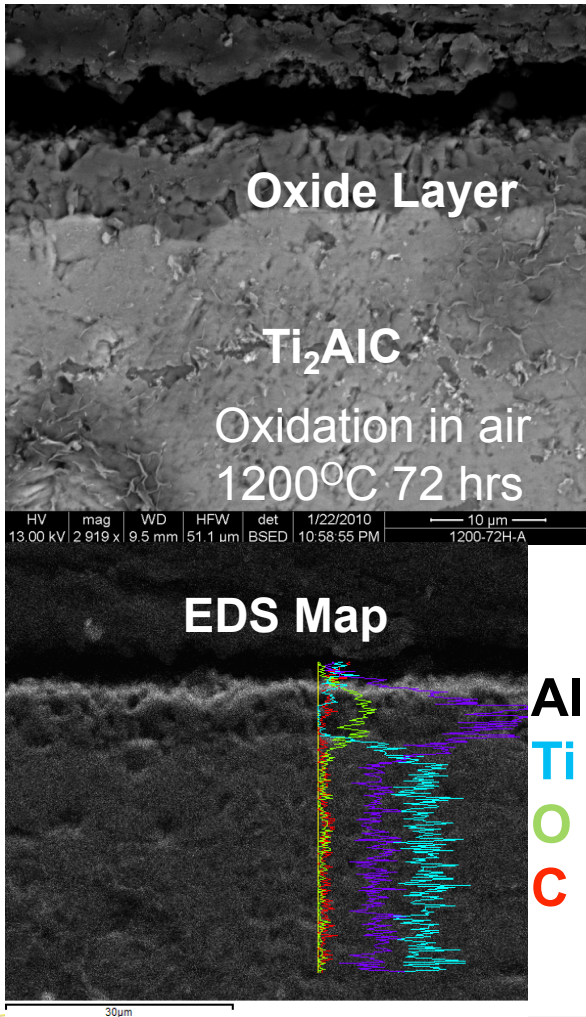

XRD analysis on the oxidized surfaces show formation of TiO_2 and Al_2O_3 layers, which subsequently controls further oxidation



AFOSR-MURI
Functionally Graded Hybrid Composites



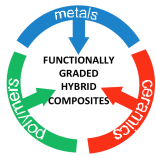

Oxidation Kinetics of Ti_2AlC Ceramics

Temp. (°C)	Cubic Rate Const. for air (kg^3/m^6s)	Cubic Rate Const. for steam (kg^3/m^6s)
1000	3.26×10^{-13}	2.55×10^{-12}
1100	2.03×10^{-12}	3.43×10^{-12}
1200	5.05×10^{-12}	1.55×10^{-11}
1300	1.03×10^{-10}	6.97×10^{-11}

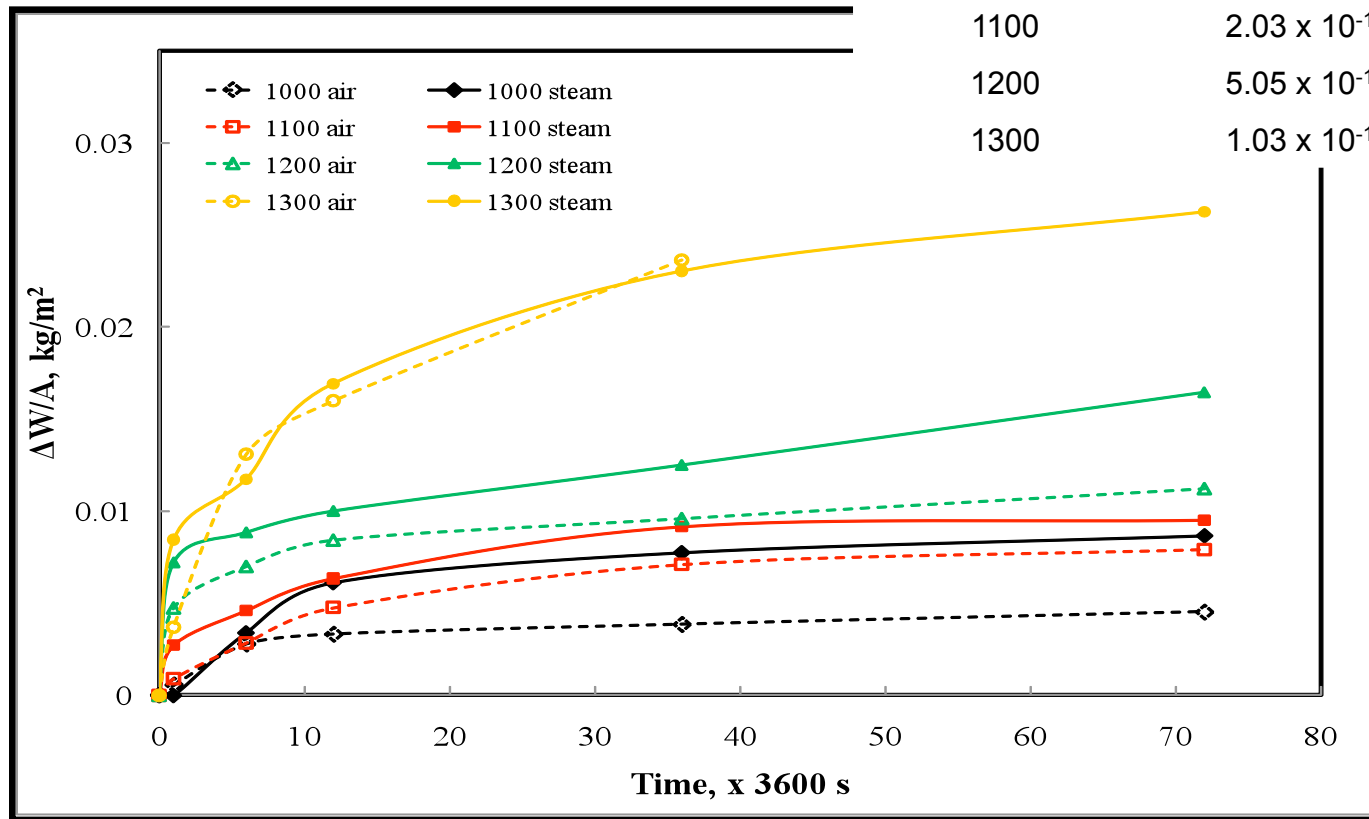

AFOSR-MURI
Functionally Graded Hybrid Composites



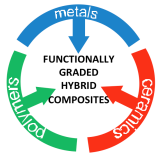

Co-Sintering of Ti-Ti₂AlC Composite

to form the ceramic-metal composite region in functionally graded structure

Mixing Different Ratios of Pure Ti and Ti₂AlC Powder

Cold Pressing

Sintering
1200°C – 5 hrs

Sintered Ti-Ti₂AlC Composites

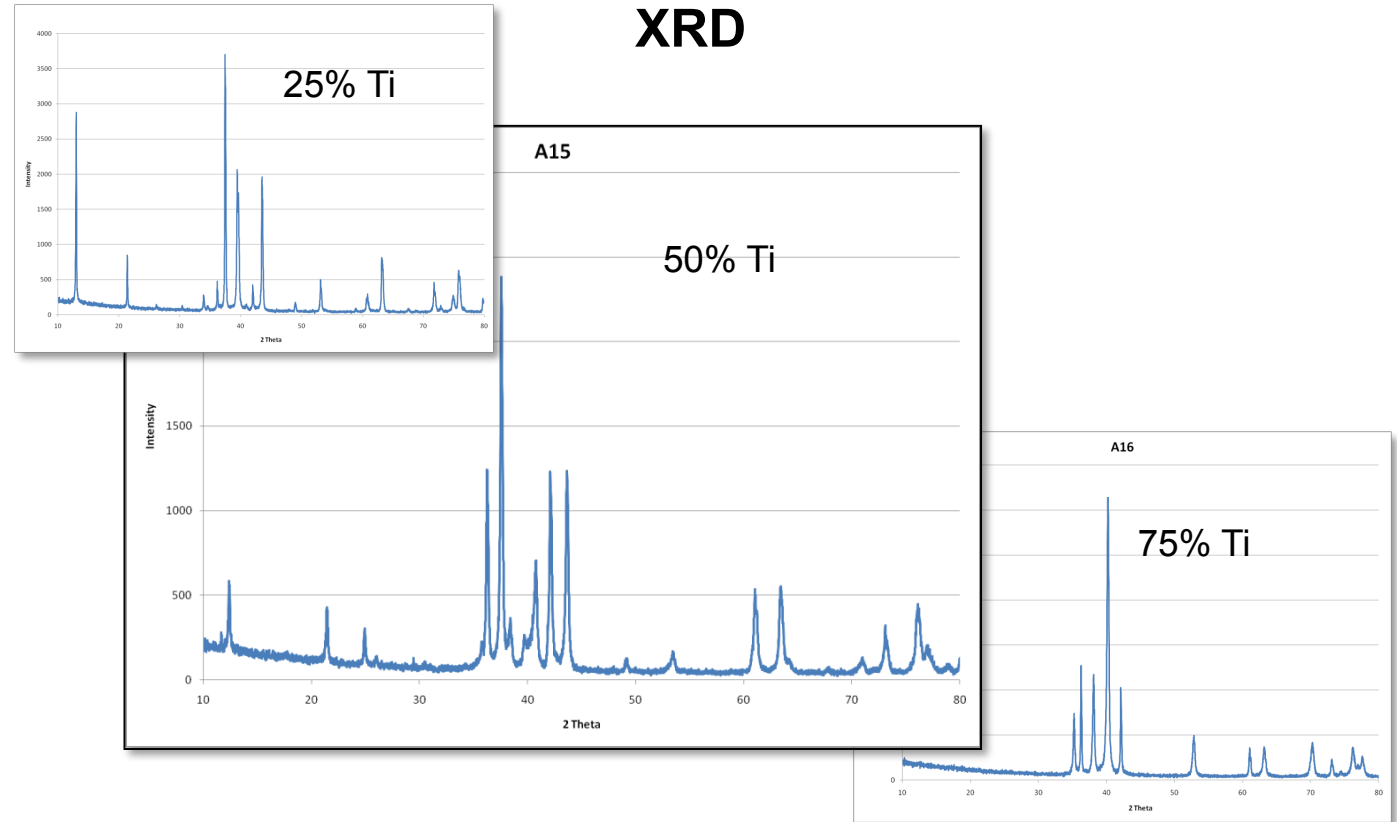

presence of small amount of Ti₃AlC phase (along with Ti, Ti₂AlC and Ti₃AlC₂)



AFOSR-MURI
Functionally Graded Hybrid Composites



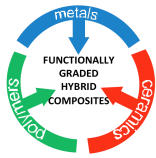

Ni₅₀Ti₅₀ - Ti₃SiC₂ Composite

to form the ceramic-SMA composite region in functionally graded structure

Vacuum Sealing in
Quartz Tube with
NiTi on top of Ti₃SiC₂



Heating at 1100°C
for 1 hr



NiTi Bonded together
with Ti₃SiC₂, ~ 50 μm
interface layer

Interface layer of about 50
micron thick formed

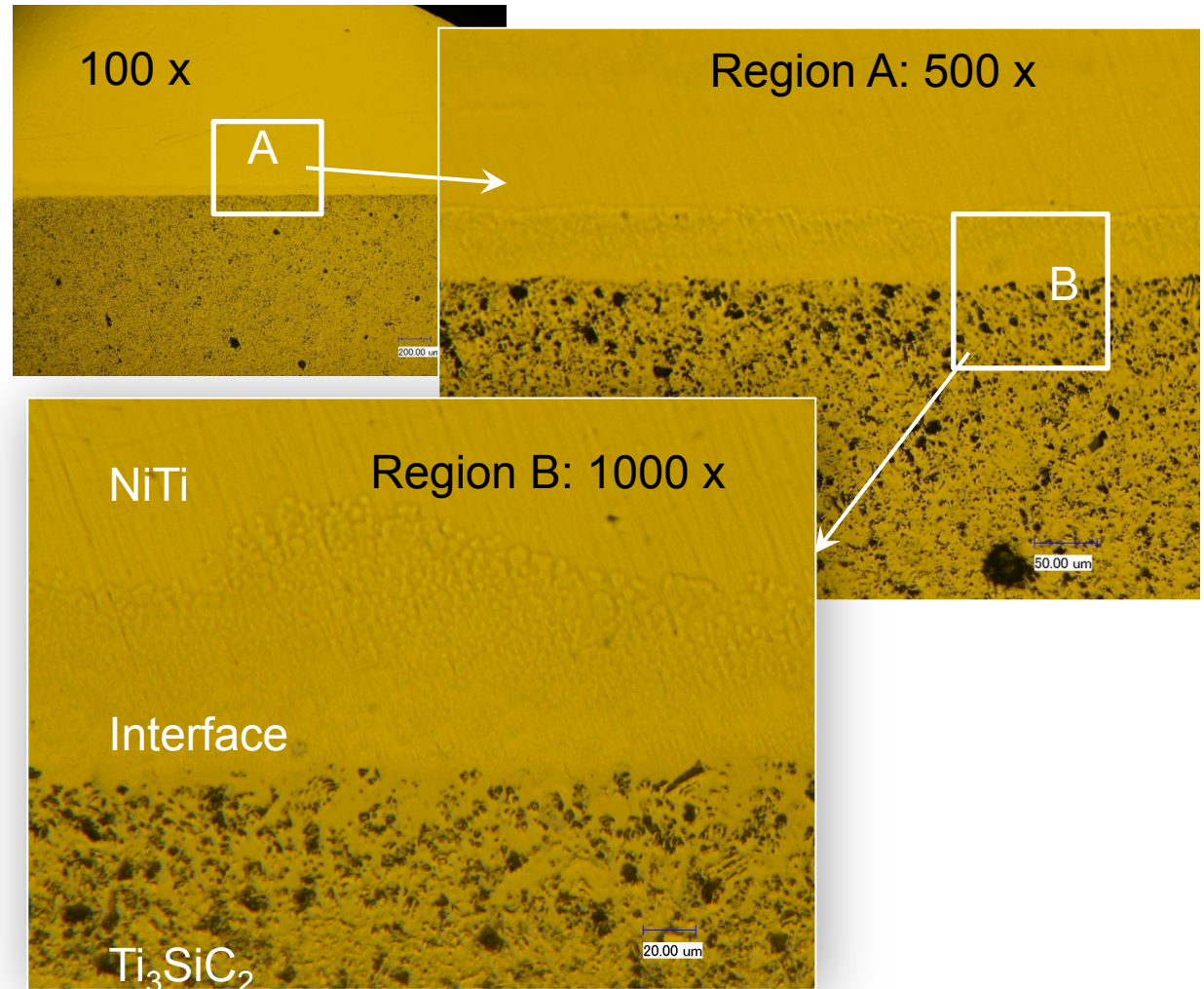

AFOSR-MURI
Functionally Graded Hybrid Composites



Virginia
Tech



UDRI
UNIVERSITY
of DAYTON
RESEARCH
INSTITUTE

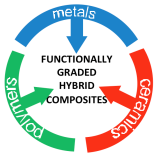

Interface of $\text{Ni}_{50}\text{Ti}_{50}$ - Ti_3SiC_2

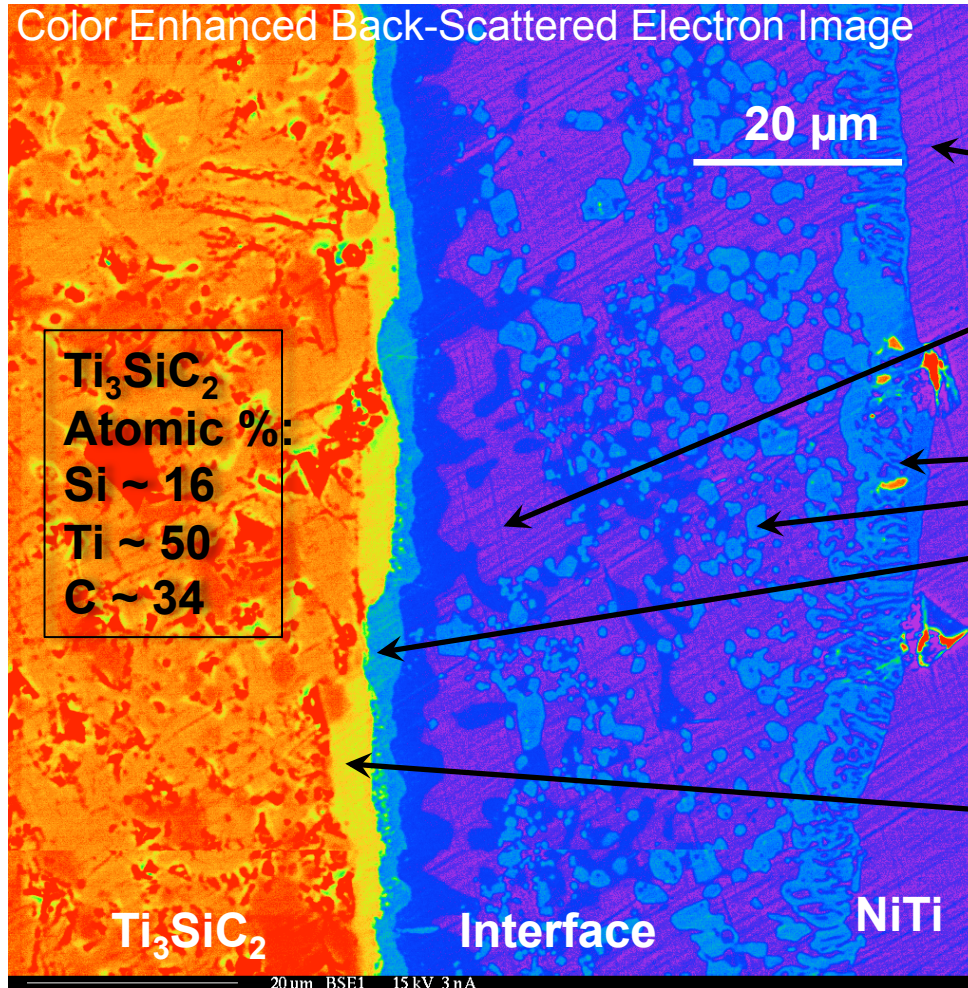

Ti_3SiC_2
Atomic %:
Si ~ 16
Ti ~ 50
C ~ 34

WDS Elemental Analysis

NiTi
Atomic %:
Ni ~ 52
Ti ~ 46
C ~ 2

Ni-Ti-Si
Atomic %:
Ni ~ 29
Ti ~ 34
Si ~ 27
C ~ 10

Ni-Ti-Si
Atomic %:
Ni ~ 30
Ti ~ 42
Si ~ 12
C ~ 16



AFOSR-MURI
Functionally Graded Hybrid Composites



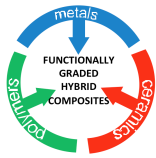

Elemental Maps: NiTi-Ti₃SiC₂ Interface

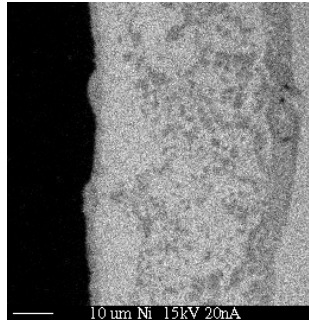

Ni

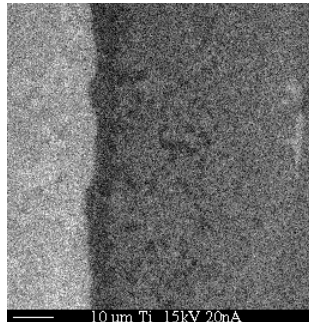

Ti

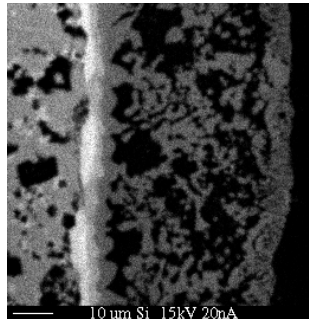

Si

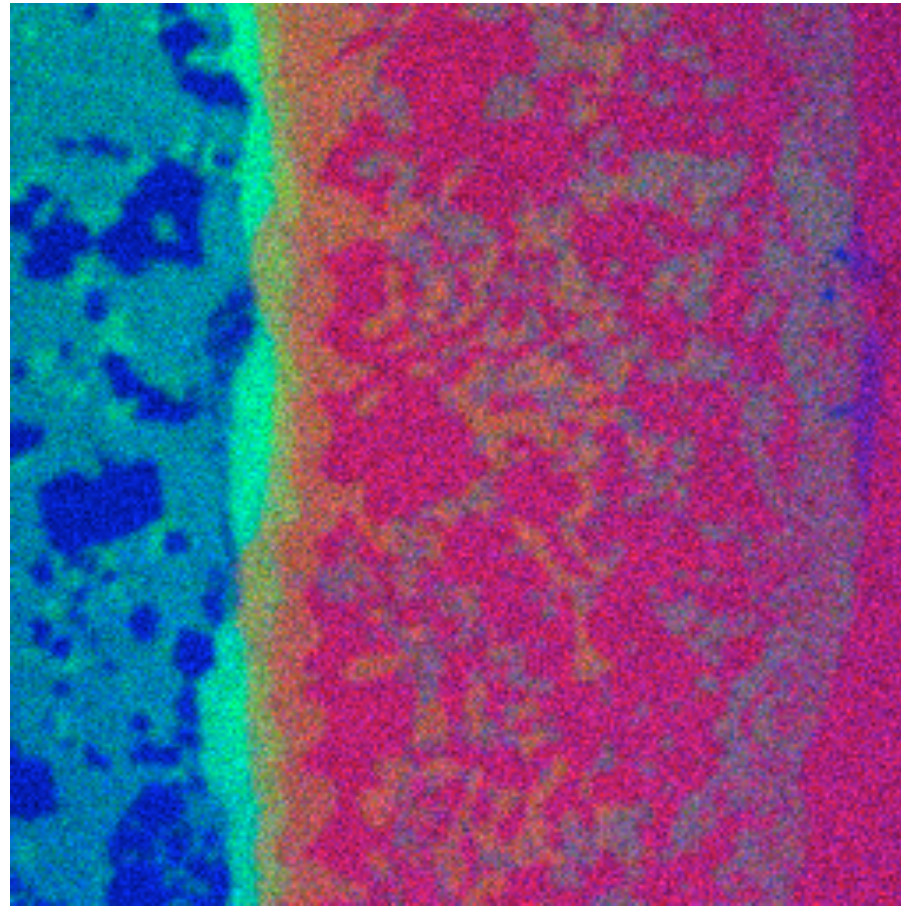

Combined image of Ni, Ti and Si elemental maps
(NiTi reacts with Si, from Ti₃SiC₂, to form the interfacial layer)



AFOSR-MURI
Functionally Graded Hybrid Composites



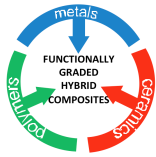

Research in Progress

- Sintering at different temperatures in a hot Press/hot isostatic press to obtain fully-dense bulk MAX phases
- Sintering of MAX phases with different amount of pore-formers at different temperatures to obtain MAX phase with controlled porosity for infiltration of metals and shape memory alloys (SMAs)
- Systematic oxidation study of bulk MAX phases in air, as well as in water vapor to understand the kinetics of protective oxide layer formation for self-healing
- Systematic fabrication of porous metal and shape memory alloys by PM method, which will be used to form high-temperature polymer infiltrated composite for stronger polymer-metal interface



AFOSR-MURI
Functionally Graded Hybrid Composites



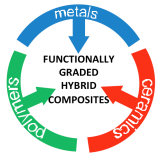

High Temperature PMC

Research Focus

- (Glass, SiC, C) fiber- and fabric-reinforced PMC for high temperature
- Adhesion of Ti (grade 2) metal to high-temperature polyimide neat resin
- Modification of metal-PMC interface through vertical nanocolumns, Z-pins, and possibly surface modification through geo-polymer additions.



AFOSR-MURI
Functionally Graded Hybrid Composites



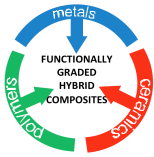

HT PMC Layer Processing

Polyimide-Based Composites

- Polyimides have good thermo-oxidative stability, resistance to moisture absorption, and relatively high moduli.
- Polyimides can withstand hot spikes up to two times their T_g .
- Viscosity tends to be elevated which makes processing a challenge

→ Solvent-assisted processing of the polymer to control viscosity.



*Solvent-assisted
Resin Transfer
Molding*



*Solution-cast, Thermal
Cure then Autoclave*



AFOSR-MURI
Functionally Graded Hybrid Composites



Virginia
22 Tech



UDRI
UNIVERSITY
of DAYTON
RESEARCH
INSTITUTE

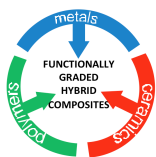

Effect of Processing on T_g

✓ Increasing nitrile content in the imide increases T_g

Nitrile Content	Polymer	T_g (°C)
0 CN		185
1 CN		217
2 CN		232
4 CN		260

✓ ThermoGravimetricAnalysis shows that polyimides are stable up to $\sim 450^\circ\text{C}$

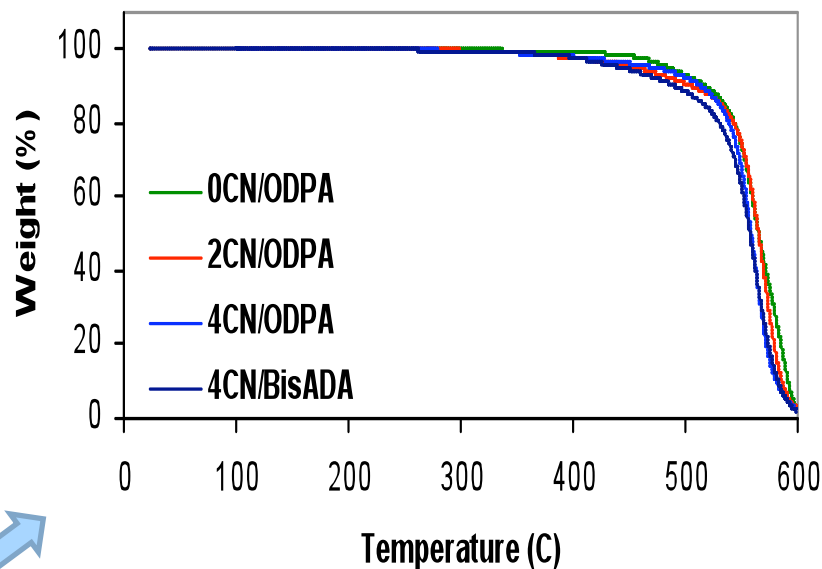

Polyimide	T (C) (5wt% loss in air)
0CN/ODPA	485
2CN/ODPA	457
4CN/ODPA	474

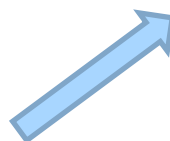

AFOSR-MURI
Functionally Graded Hybrid Composites



Virginia
28 Tech



UDRI
UNIVERSITY
of DAYTON
RESEARCH
INSTITUTE

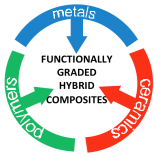

Actively-Cooled PMC (AC-PMC)

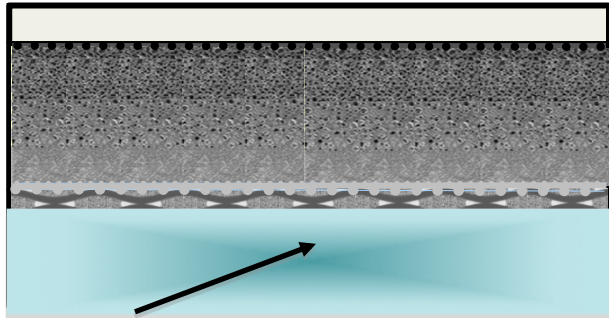

Actively cooled polymer matrix composite (AC-PMC) layer

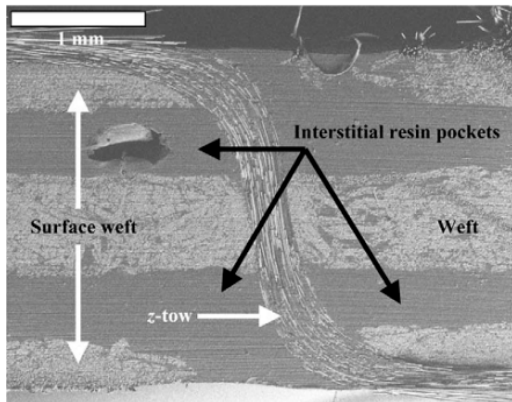

3-D Woven Microvascular Composites. 3D orthogonally woven monolith with 56% fiber content

AC-PMC Concepts

- Short term: 2D planar array of embedded micro-channels layered within a PMC
- Long term: 3D woven PMC architectures with integrated microvascular networks with sacrificial fibers co-mingled with reinforcement tows

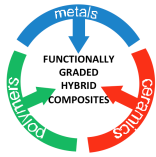

Multi-scale Characterization

Characterization of Composite Layers

- Graded Ceramic/Metal Matrix Composites
- Polymer/Matrix Composites
- Local Strain Fields/Damage Initiation

Interfaces and Bonded Joints

- Thermal Impedance
- Interfacial Delamination

Structural Performance

- Impact Response
- Vibration Analysis

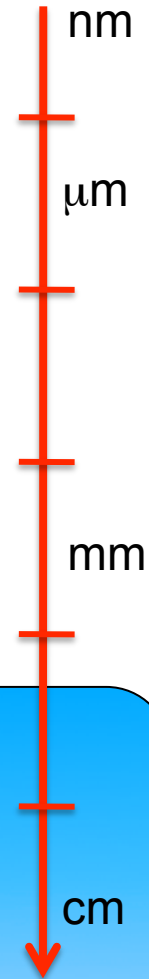

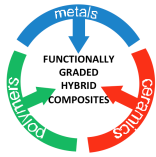

Constituent Characterization

**High Temperature X-Ray
Diffractometer (up to 1500K)**

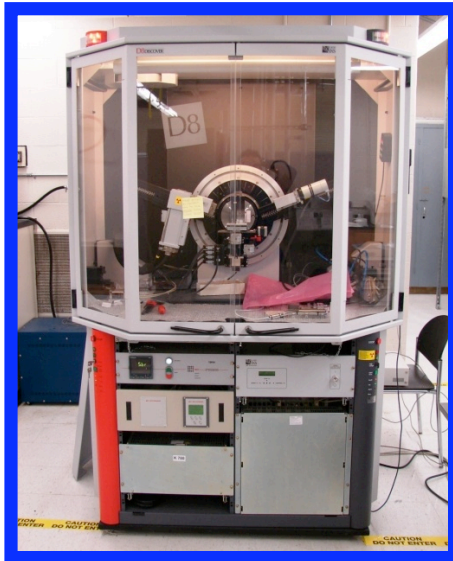

**Micro CT for non-destructive
characterization of metallic and
ceramic phases and porosities**

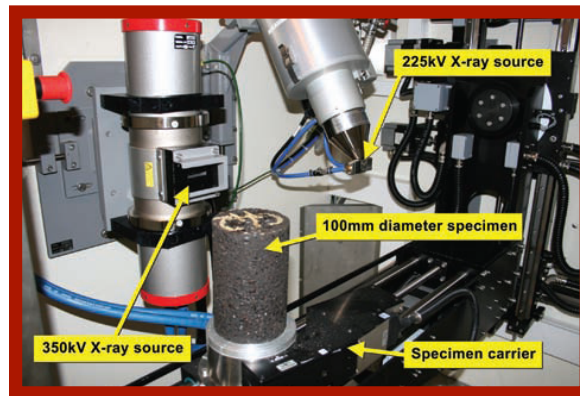

**Hermetic, beryllium dome
high temp heating stage
under 6×10^{-7} mBar vacuum**

**Electron Microprobe Analyzer and
Wave Dispersive Spectroscopy (WDS)**
to study compositional variations across
interfaces

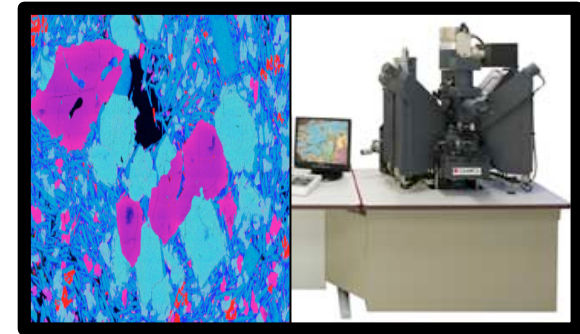

**SEM and Orientation Imaging
Microscopy (OIM) for phase morphology,
distribution, and texture**



**AFOSR-MURI
Functionally Graded Hybrid Composites**



Daehn et al. URET presentation

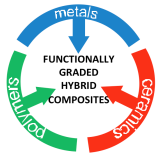

Thermo-mechanical Testing

Tensile, compressive, 4-point bend, double torsion

Fixture for high temperature double torsion.

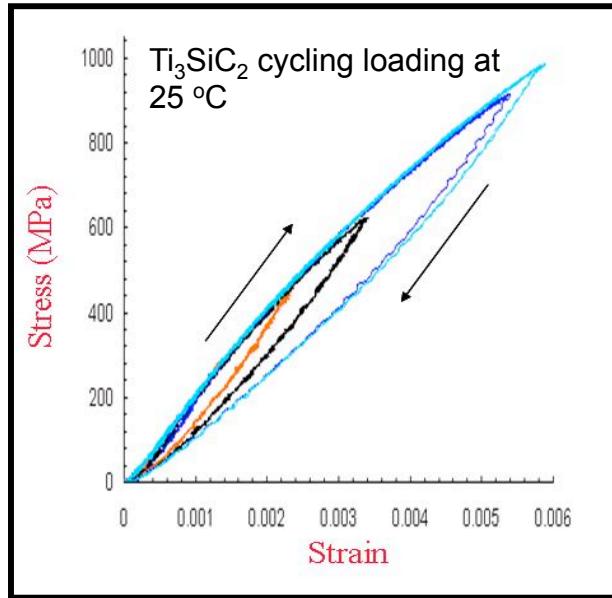
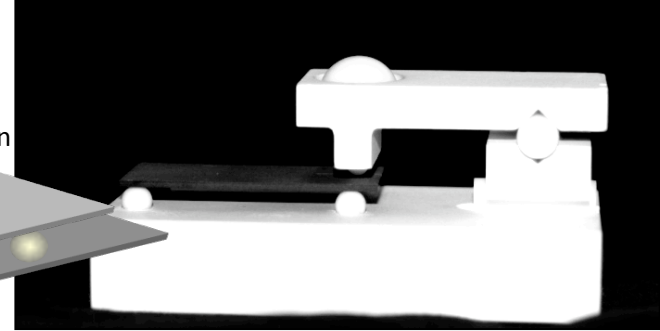

Barsoum, Zhen, Kalidindi, Radovic and Murugaiah, Nature Materials, 2 (2003)

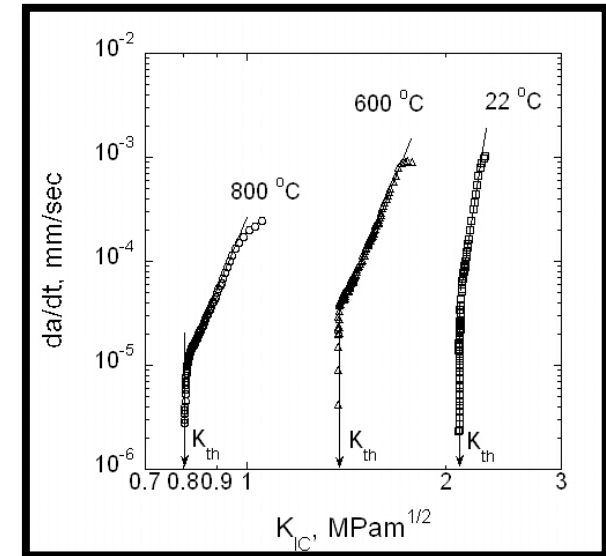
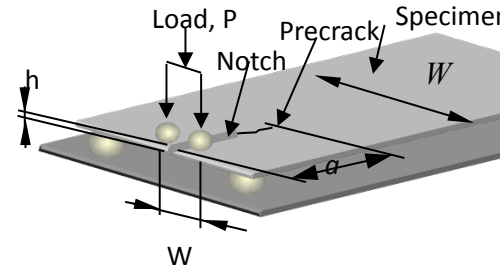

Radovic M., Lara-Curzio E., Nelson G. Ceramic engineering and science proceedings , Vol. 27 (2007)



AFOSR-MURI
Functionally Graded Hybrid Composites



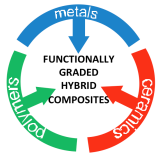

Resonant Ultrasound Spectroscopy

- Young's and Shear moduli from resonate spectrum of the material;
- One of the most accurate technique;
- Unique RUS equipment for measurements in 25-1300 °C and controlled environment developed at Texas A&M.

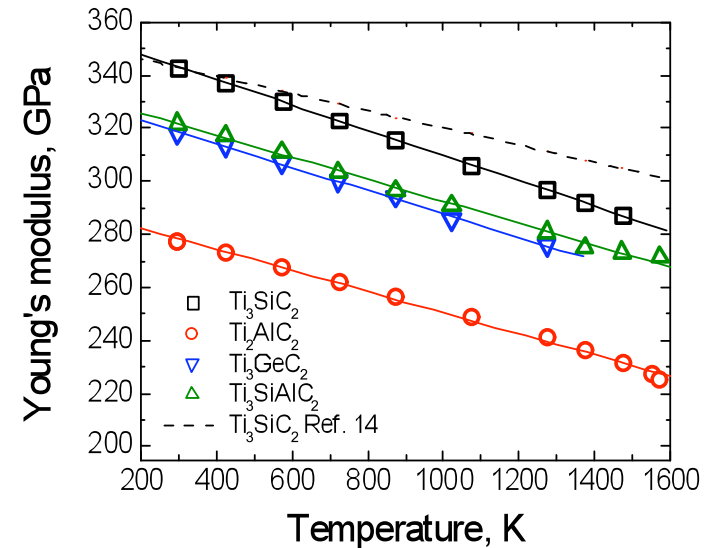
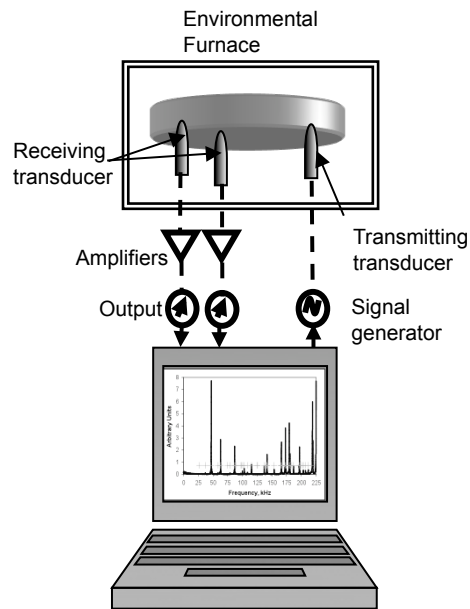

Radovic M. et al, JMR, Jun (2008)
 Radovic M. et al, Acta Mat, 54 (2006)
 Barsoum M.W., Radovic M. et al, Phys. Rev. Lett. 94 (2005)
 Radovic M., et al., Mat. Trans. A, 368 (2004)



AFOSR-MURI
 Functionally Graded Hybrid Composites



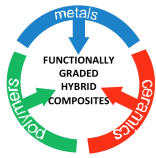

PMC Characterization

- A full suite of experimental techniques will be used to aid manufacturing development studies and mechanical/thermal performance assessment

Material	Experimental Technique	Characterization
Matrix Resin	Rheology	complex viscosity
	DSC	cure kinetics
	DMA	mechanical properties
Composite material	DSC	cure kinetics
	DMA	mechanical properties
	Optical/electron/fluorescent microscopy	material architecture
	Micro-CT	material architecture
Microvascular composite	IR imaging	surface temperature field
	Fluorescent microscopy	internal fluid temp
	Micro-CT	network architecture
	Micro-PIV	flow characteristics



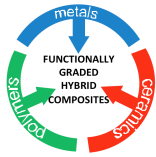

Joining GCMcC and PMC

➤ Bonding

- vertical nano-columns
- intermediate fabric preform with vertical nano-columns
- Z-pinning technique

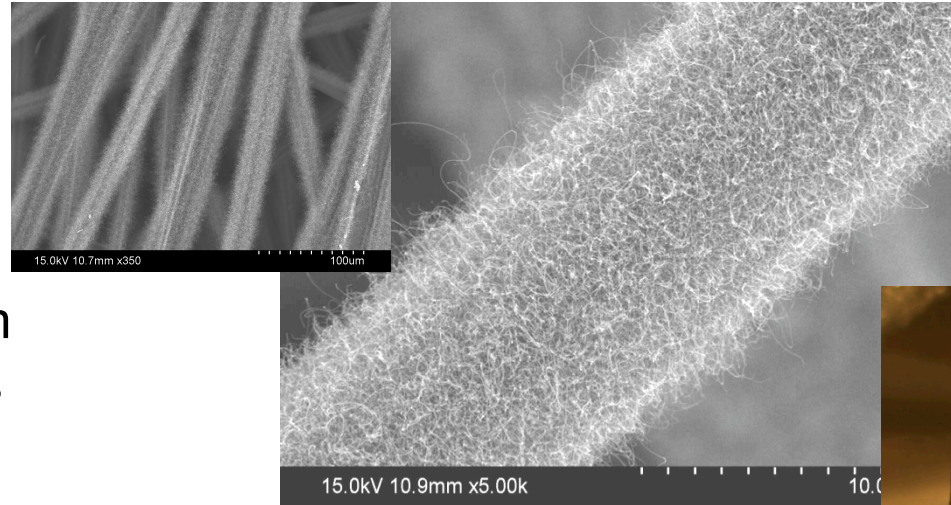

Hybrid Fiber Strain Gage

CNT Fuzzy Glass fiber was attached to voltmeter to measure changes in resistance as tension test progresses

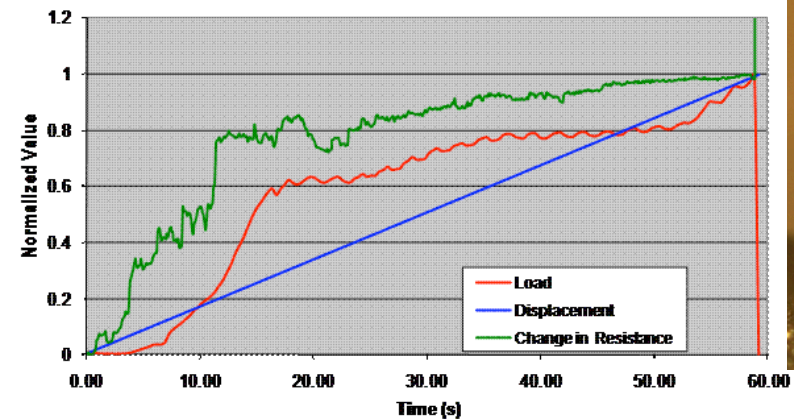

AFOSR-MURI
Functionally Graded Hybrid Composites



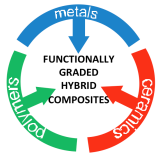

Digital Image Correlation (DIC)

Displacement-Strain Measurements

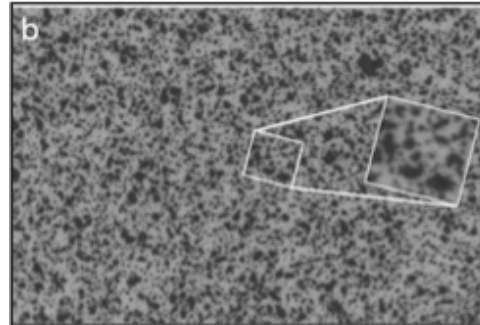
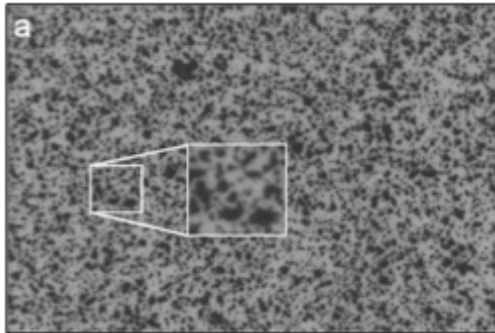

$$x'_{q'} = x_q + u_{x_p} + \frac{\partial u_{x_p}}{\partial x} \Delta x_q + \frac{\partial u_{x_p}}{\partial y} \Delta y_q$$

$$y'_{q'} = y_q + u_{y_p} + \frac{\partial u_{y_p}}{\partial x} \Delta x_q + \frac{\partial u_{y_p}}{\partial y} \Delta y_q$$

Can control resolution through speckle pattern.

Macroscale: $\pm 25 \mu\text{m}$
black spray paint

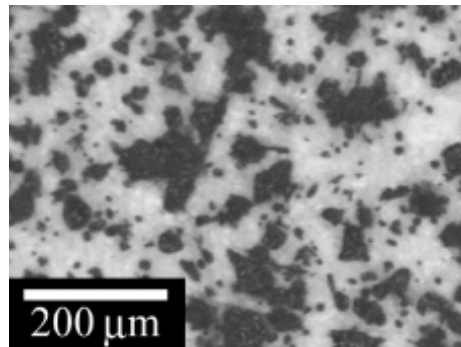

Microscale: $\pm 1 \mu\text{m}$
air-brushed pattern

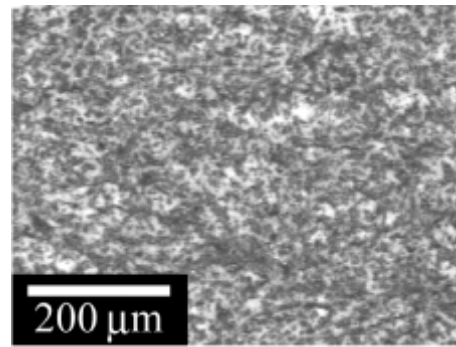

Nanoscale: $\pm 10 \text{ nm}$
fluorescent nanoparticles

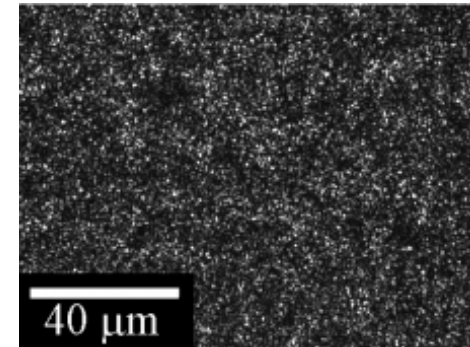

AFOSR-MURI
Functionally Graded Hybrid Composites



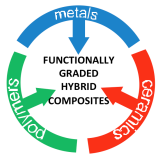

Localized Strain Measurements

Strain concentrations due to vascular cooling networks

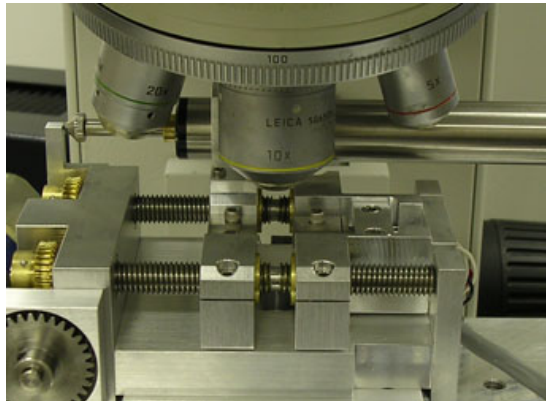

μ VAC cross-section exposing channels

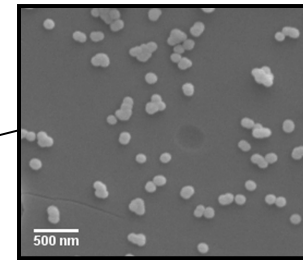
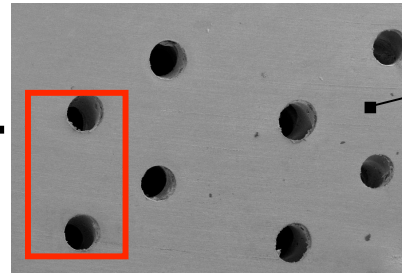

SEM of nanoparticles on sample surface

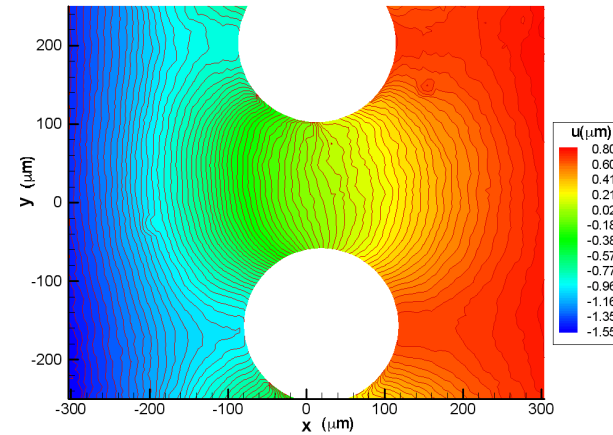
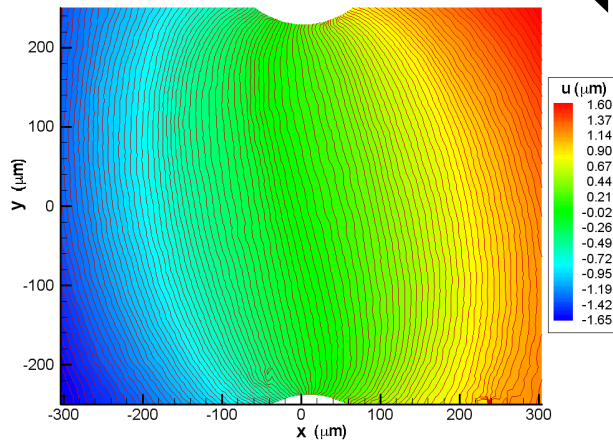

AFOSR-MURI
Functionally Graded Hybrid Composites



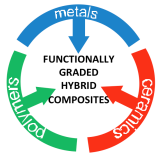

Micro and Nano X-Ray Tomography



MicroCT reveals material architecture

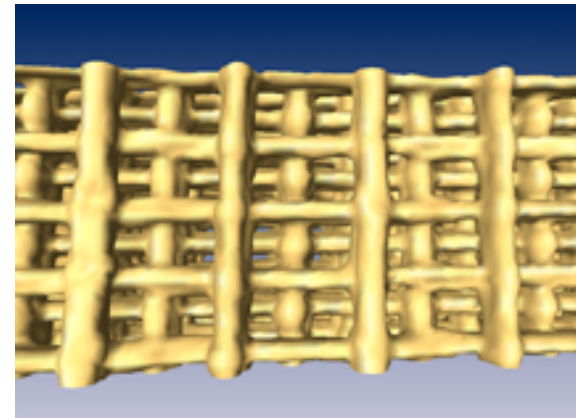

Lens based x-ray microscopy

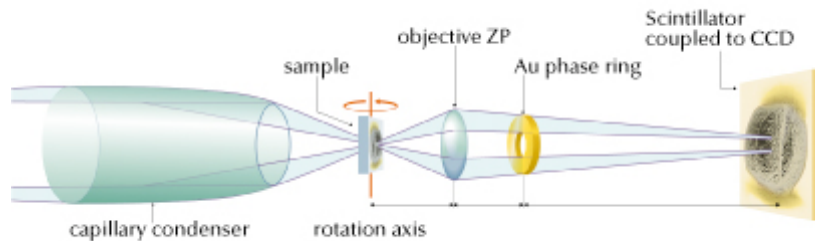

FEA models will be based on **microscopy** and **micro-CT observations** of functionally graded surfaces.

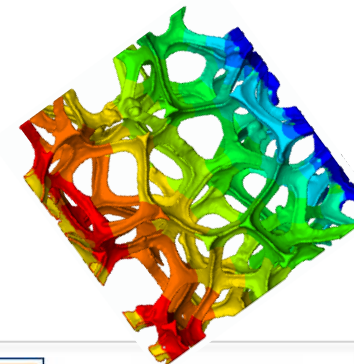

AFOSR-MURI
Functionally Graded Hybrid Composites



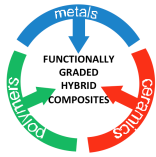

Thermal Impedance to Characterize CNT- TIM

Requirements of Thermal Interface Material

- conform to mating surface
- good wettability
- provide high conductivity path

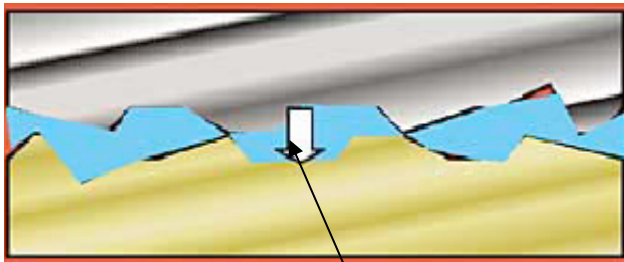

interfacial material

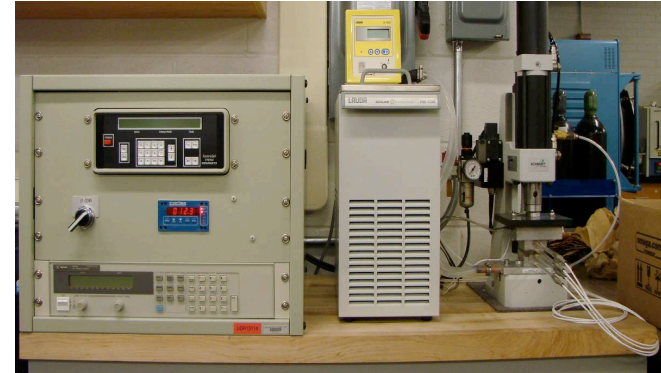
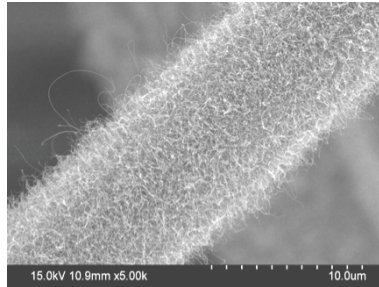

ASTM D5470 Thermal Interface Material Testing System

Ref. Product	Thermal Impedance [$^{\circ}\text{C}$ in^2/W]
Dry Test	0.160
Arctic Silver	0.013
Aremco 640	0.060
Circuit Works Grease	0.018
Omegatherm 201	0.054
PowerFilm 51	0.474

Sample type	Thermal Cond.W/m.K	Enhancement %
Aluminum solid	95.73	--
Aluminum pieces in direct contact	8.957	--
Aluminum pieces with graphite spray	37.983	324.06
Aluminum pieces with CNT/TIM	43.457	385.16



AFOSR-MURI
Functionally Graded Hybrid Composites



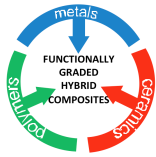

Interfacial Fracture Testing

- Assess interfacial integrity of GMeC/PMC with DCB test for Mode-I and ENF test for Mode-II loading from room temperature to 1000 °C.

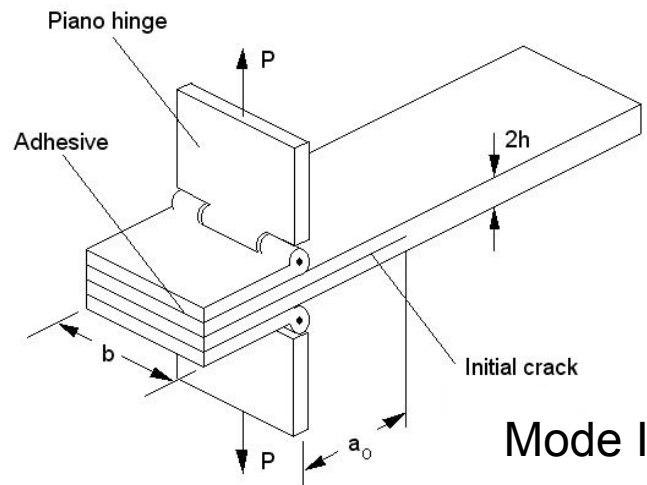

Mode I

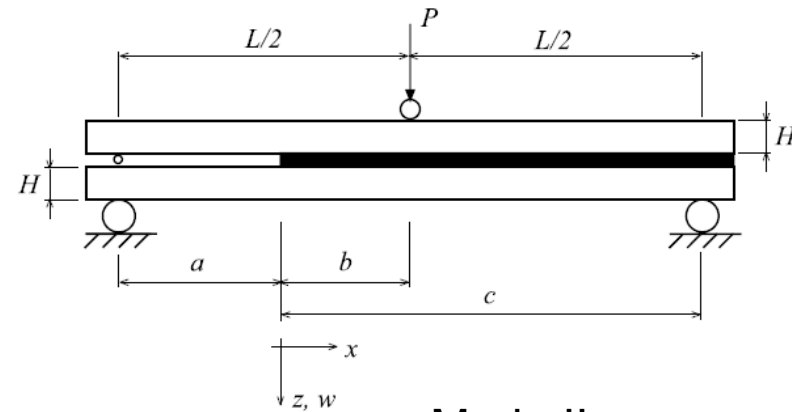

Mode II

- Combined mesoscale characterization (SEM) and macro-scale characterization will provide insight in to the fracture



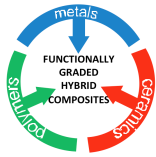

Impact & Vibration Characterization

Effect of microstructure and FGHC assembly

- Quasi-static, drop tower, and instrumented gas gun
- VT altitude chamber
- Identify damage mechanisms and dominant failure modes
- Observe interactions at the interfaces
- Strain rate dependence

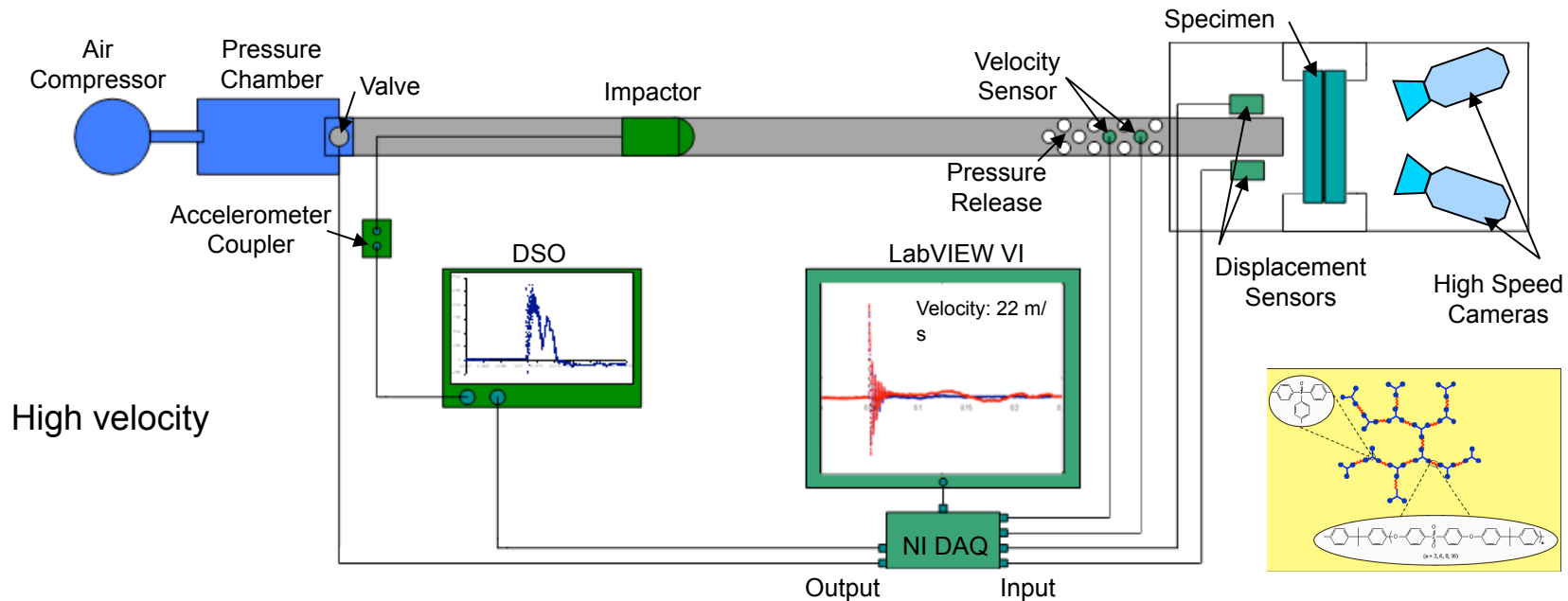

AFOSR-MURI
Functionally Graded Hybrid Composites



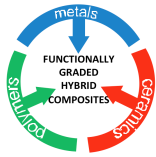

Dynamic Shear Strength Bonded Structures

- Evaluate the dynamic shear strength of interlayers and joining techniques
- Determine the static and dynamic adhesive shear strength between functional layers as a function of component properties and process conditions.

Adhesive Shear Stress vs. Strain
VHB Foams - Strain Rate - 0.001 s^{-1}

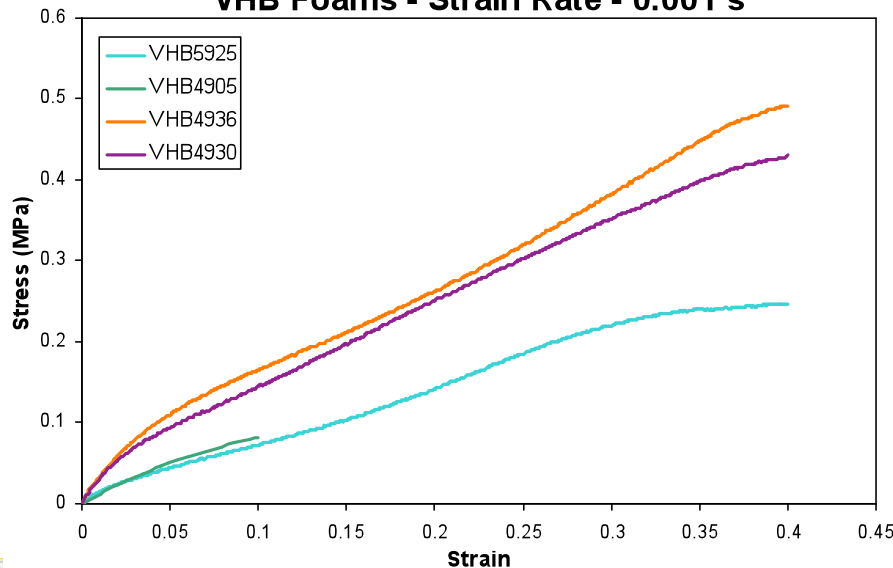

Test specimen

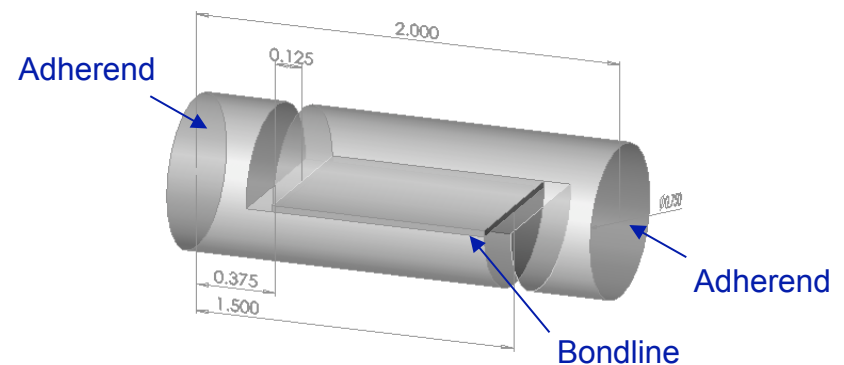

AFOSR-MURI
Functionally Graded Hybrid Composites



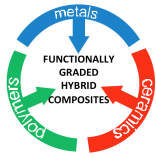

High Temperature SHM/NDE

In-situ characterization of the integrity of FGHC

Sensors & Sensing Network

Diagnostic Algorithms

Modeling

Integration & Characterization



AFOSR-MURI
Functionally Graded Hybrid Composites



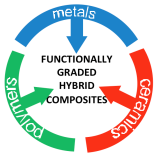

Sensors and Networks

Monitoring the health state of the hybrid composite materials during manufacturing and in service

Sensor Network development

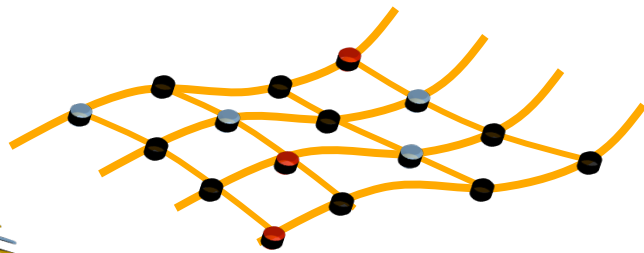
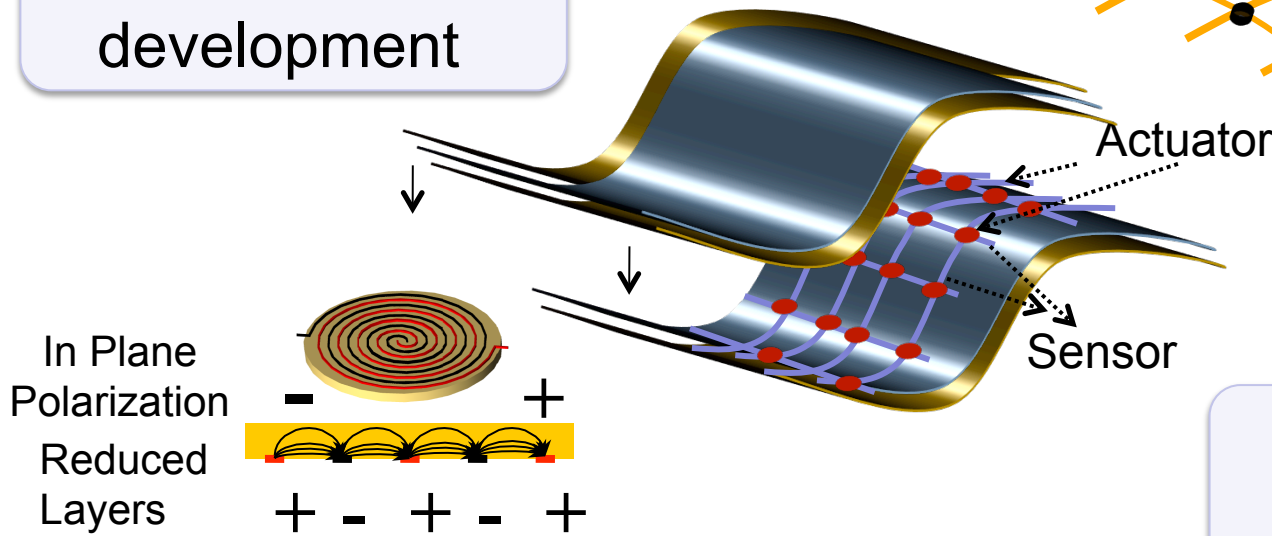

Sensors development



AFOSR-MURI
Functionally Graded Hybrid Composites



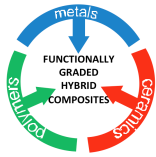

Sensor Development: Piezoelectrics

- High Curie Temperature piezoelectric ceramics:
 - commercially available Bismuth titanate and BST-lead titanate with $T_c \sim 500-600^\circ\text{C}$.
 - Lead titanate-based single crystals
- Flexible 0-3 piezoelectric composites:
 - Piezoelectric inclusions in polymer matrix



β CN-PI/PZT/SWNT



AFOSR-MURI
Functionally Graded Hybrid Composites



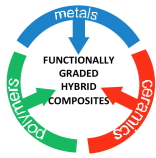

Sensors Development: Nanomaterials

Conductivity changes



Strain, damage

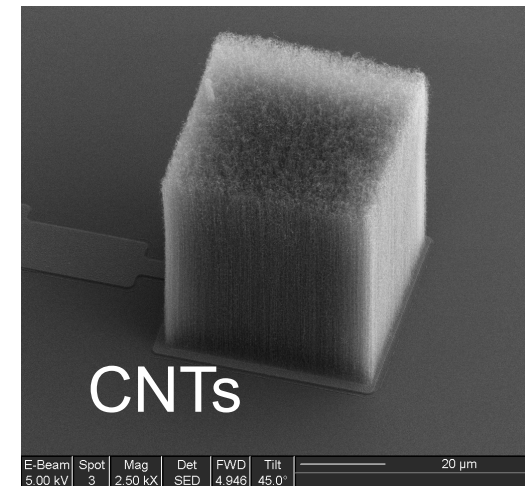
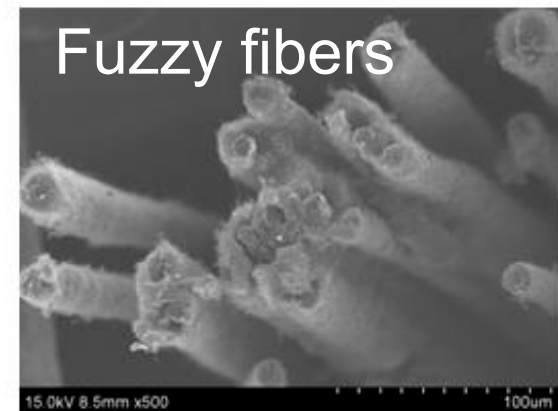
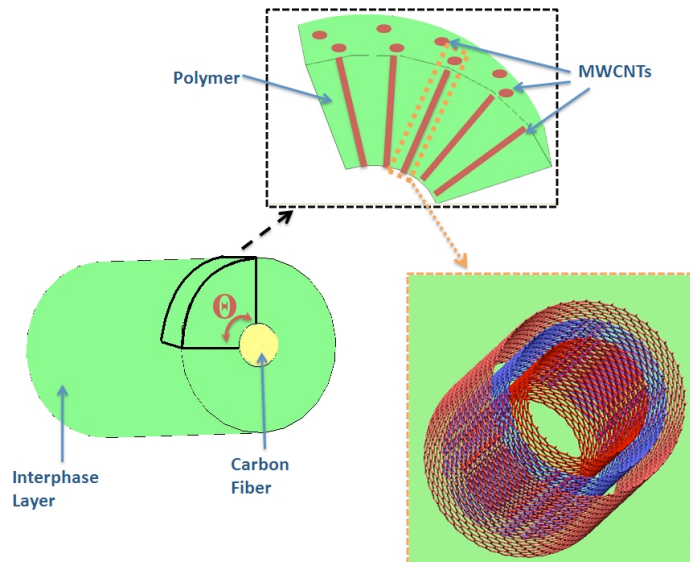

AFOSR-MURI
Functionally Graded Hybrid Composites



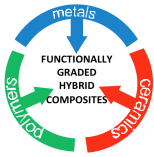

Integration and Characterization

Testing of Complete SHM/NDE System in Hybrid Composite

Complete system development

- Integration
- Evaluation
- Characterization

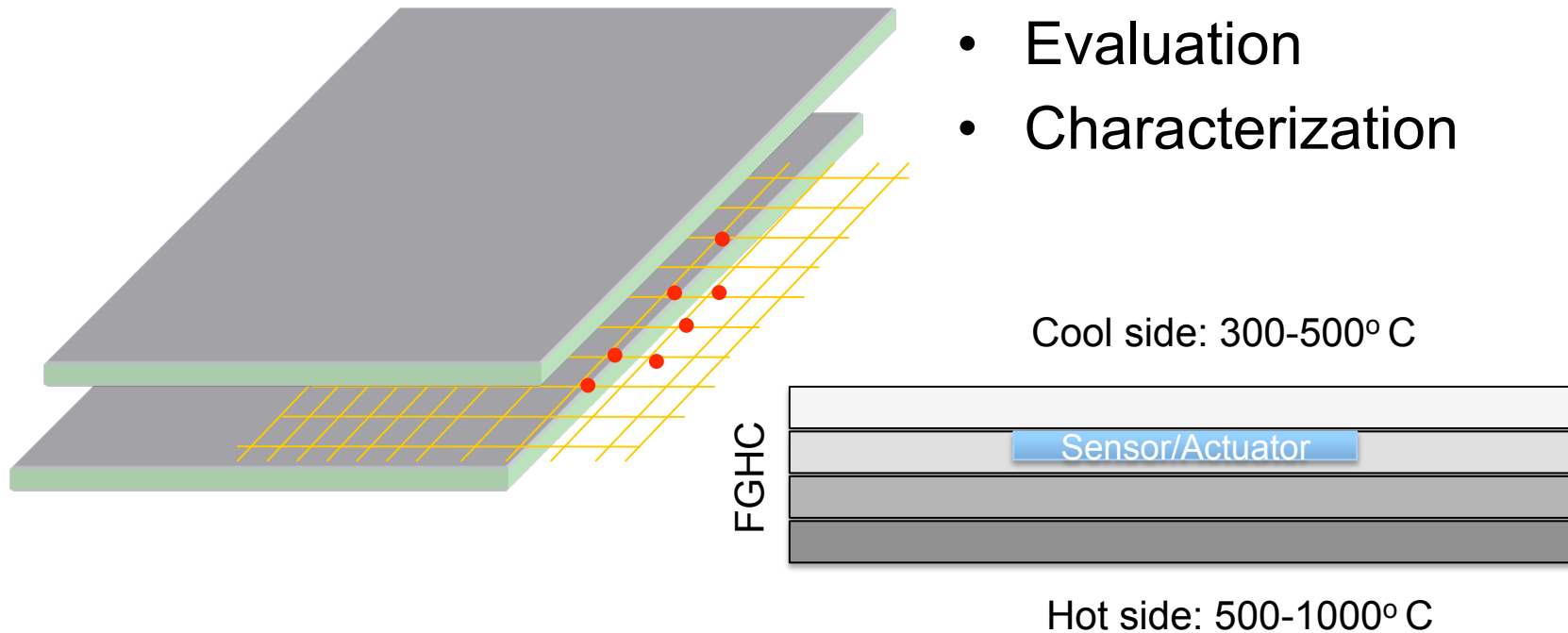

AFOSR-MURI
Functionally Graded Hybrid Composites



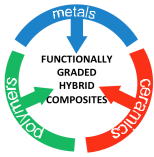

Diagnostics/Algorithm Development

- Adapt algorithms to account for extreme temperature changes
- Develop methods to distinguish damage types
- Focus on impact force identification methods
- Develop vibration based approach to track damage induced by impact



Hybrid material with internal (Right) and externally (left) affixed PZT SMART layer networks.

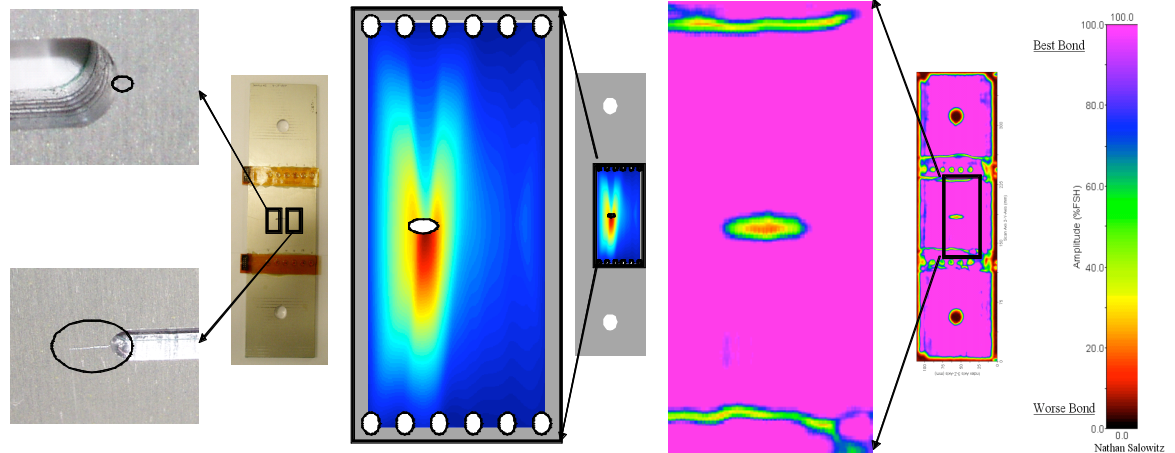

a) Hair line cracks detected by visual inspection on hybrid laminates, b) Diagnostic image by SHM detected the presence of these cracks, c) Traditional NDE.



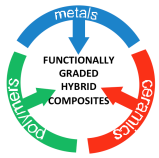

Multi-scale Modeling of FGHC

Wide Range of Scales

Fuzzy fiber

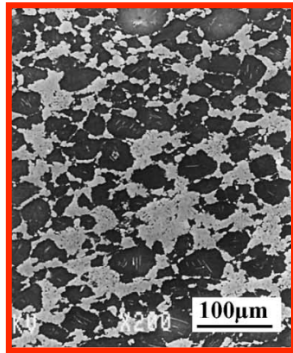
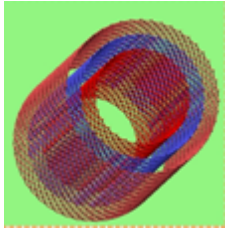

1000°C

GCMcC

300-400°C

PMC

Optimize FGHC

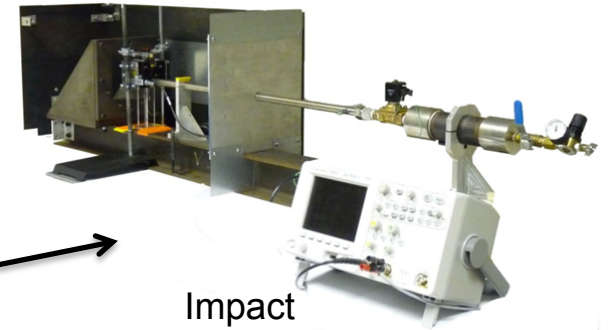
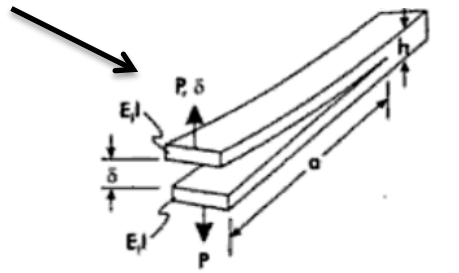

Impact



AFOSR-MURI
Functionally Graded Hybrid Composites



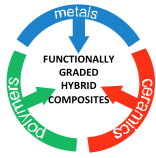

Modeling Goals

- Predict performance of material and components
- Develop strategies for joining parts
- Expedite mechanical and thermal design
- Define in-flight mechanical and thermal loads



AFOSR-MURI
Functionally Graded Hybrid Composites



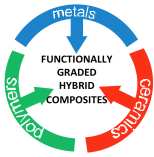

GCMeC

Interpenetrating Phase Composite

Preform is random open-cell foam

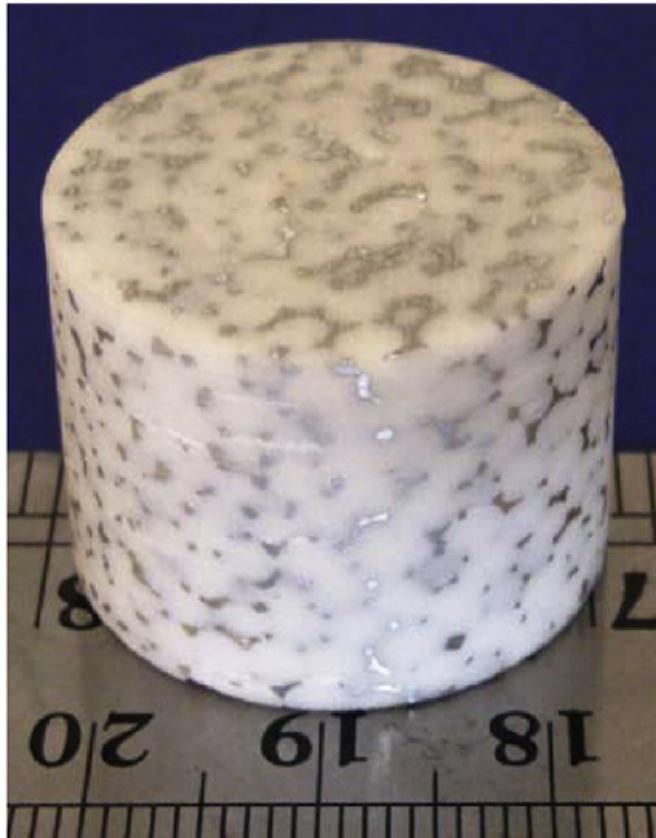

(Jhaver and Tippur, *MSE-A*, 2009)

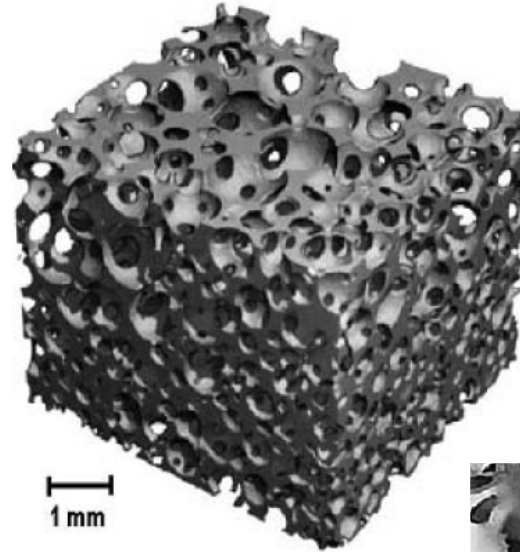

Micro-CT image

(Colombo & Hellmann, *Mat. Res. Innovat.*, 2002)

SEM micrograph
of Al_2O_3 preform

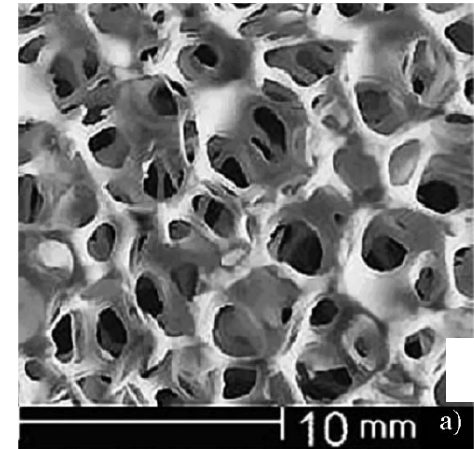

AFOSR-MURI
Functionally Graded Hybrid Composites



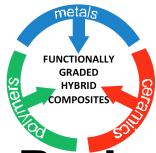

Random Cell Model

- Periodic random models – Preliminary Work**

- Start with **reference model**: structure with regular cell shapes and uniform struts
- Construct from a set of **periodically located seeds** using **Voronoi tessellation** technique

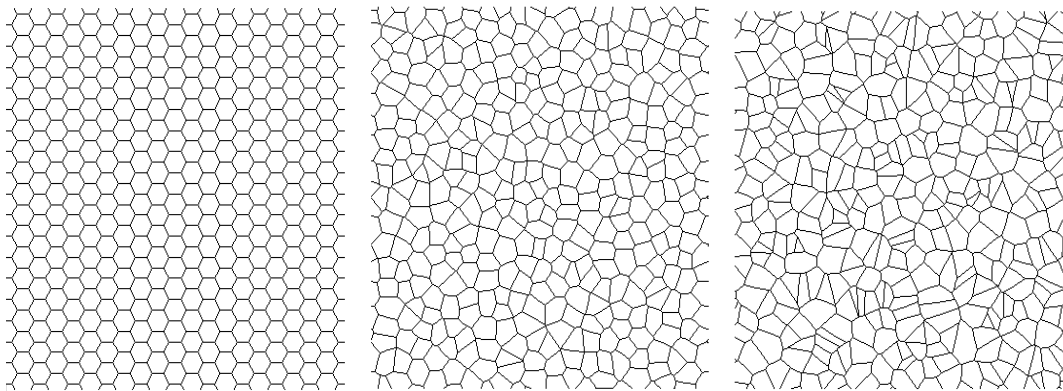

Reference ($a = 0$) Random ($a = 0.5$) Random ($a = 1.0$)

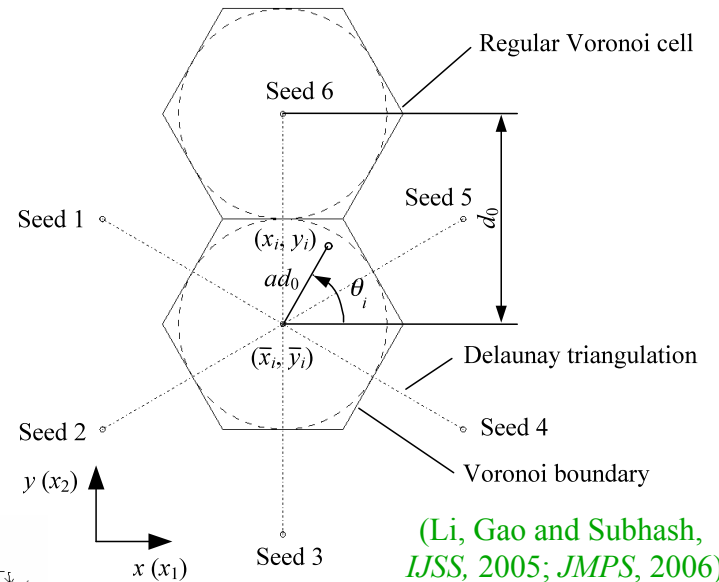
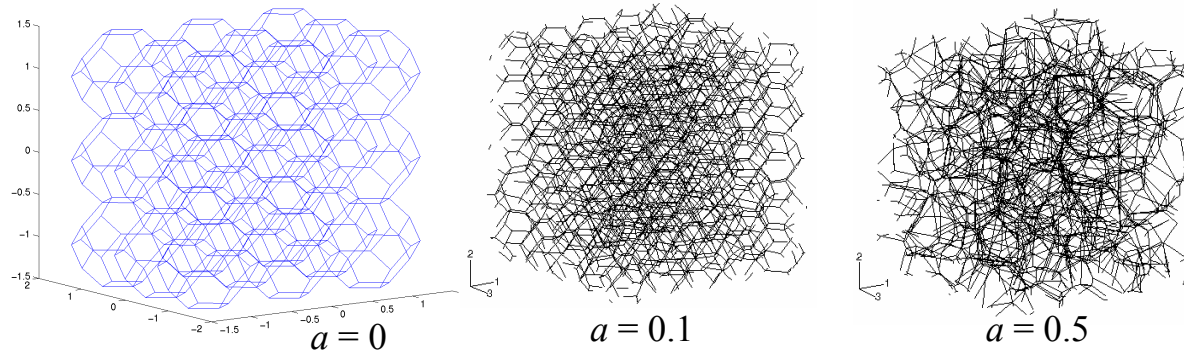

Coordinate perturbations of a seed

$$x_i = \bar{x}_i + a(d_0 \cos \theta_i) \varphi_i,$$

$$y_i = \bar{y}_i + a(d_0 \sin \theta_i) \varphi_i,$$

$$\theta_i \in [0, 2\pi], \quad \varphi_i \in [-1, 1],$$

cell shape irregularity amplitude



AFOSR-MURI
Functionally Graded Hybrid Composites



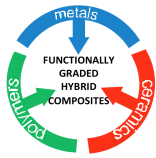

Multi-scale Progressive Damage in Complex Microstructures

- Develop and utilize a multiscale modeling framework that will
 - allow investigation of the details of damage initiation and evolution in an FGHC consisting of a thermal barrier layer, a GCMcC and a PMC layer
 - correlate changes in nanocomposite mechanical, electrical and electromechanical properties

- Adaptive computational micromechanics tools which integrate

- molecular dynamics
- finite element analysis
- homogenization

- MD to incorporate nanoscale interface effects and interphase layers into continuum level models (inelastic cohesive zone models)

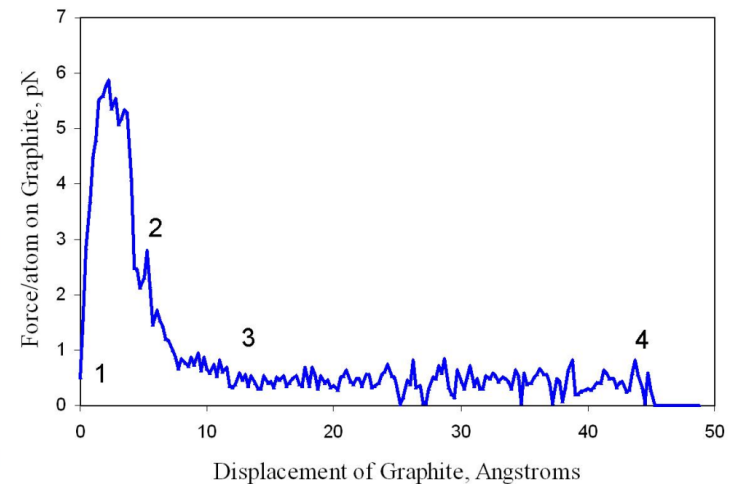
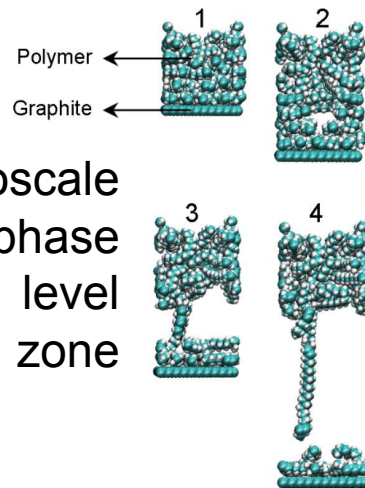

Normal separation between graphite and polymer: force-displacement response



Multi-scale/Multi-field Modeling of Damage

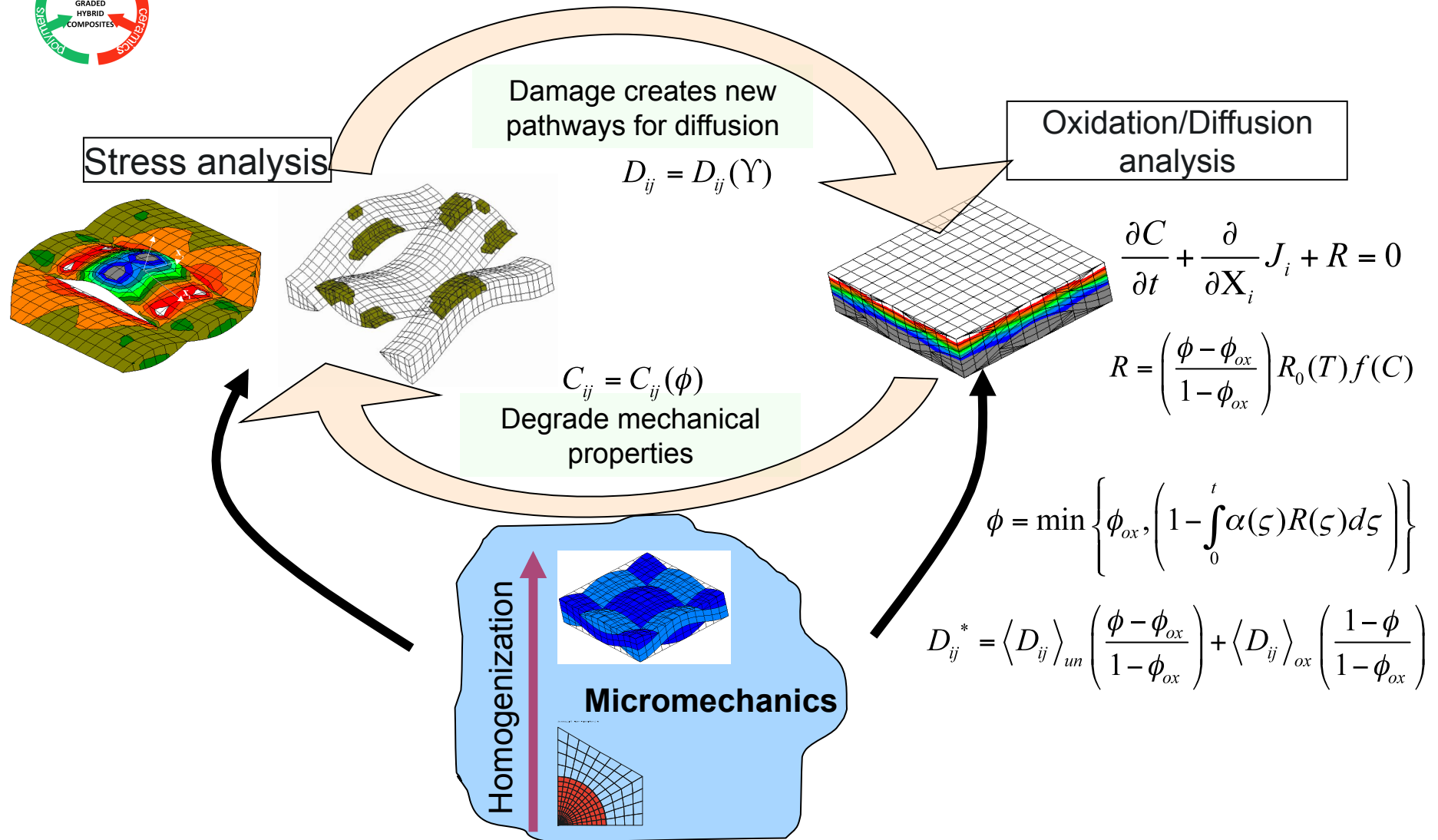
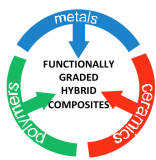

AFOSR-MURI
Functionally Graded Hybrid Composites



also, heat transfer



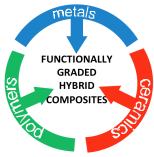

Actively Cooled Woven PMC

- Design microvascular networks embedded 2D and 3D woven PMC
- Predict homogenized thermo-mechanical response
- Technical challenges
 - Representation of composite microstructure
 - Design of network template compatible with microstructure and manufacturing constraints
 - Problem size
 - Validation with thermal and constitutive/failure assessments (White and Sottos)
 - Multiscale thermal and structural modeling

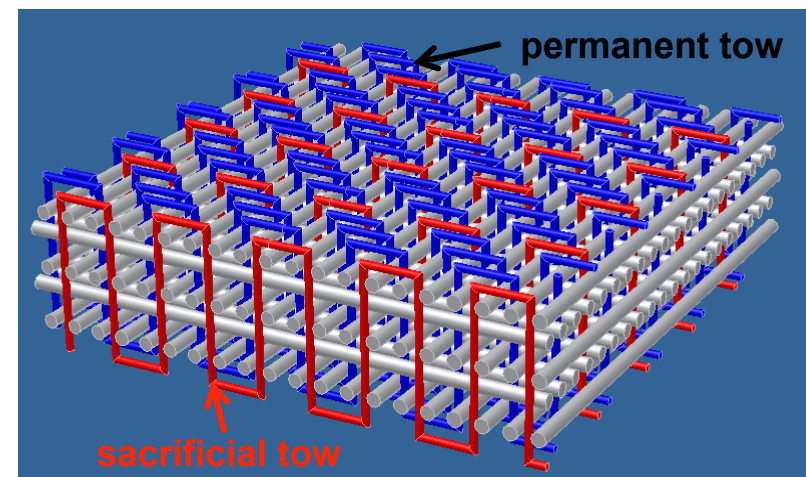

AFOSR-MURI
Functionally Graded Hybrid Composites



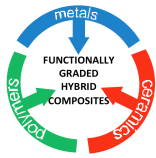

Viscoplastic Behavior of High-Temperature Active Layers

Use shape memory effect to absorb energy and induce compressive stresses in ceramic

- High temperature=> viscoplastic response becomes an important issue for the metallic constituent
- Creep is directly coupled with the transformation behavior of high-temperature SMAs

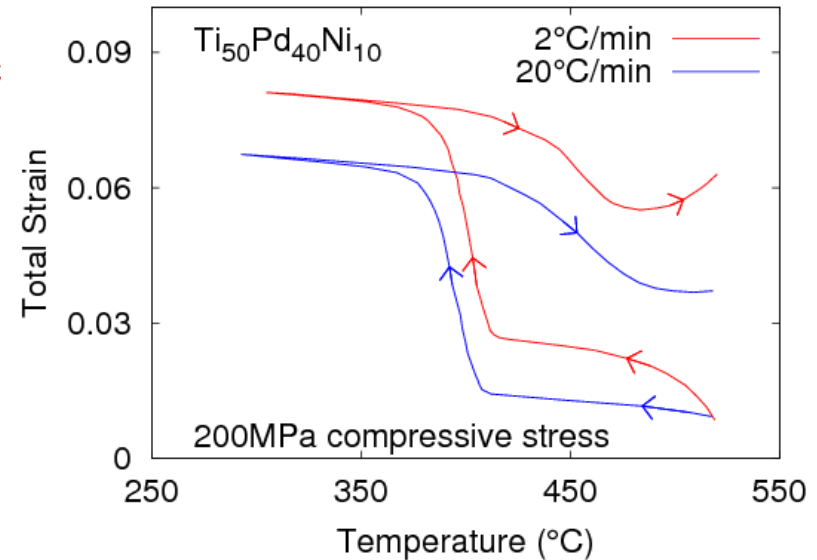

- Characterize overall creep behavior of GCMeC
- Optimize microstructure with respect to its inelastic performance
- Obtain effective creep properties by extending multiscale homogenization techniques



AFOSR-MURI
Functionally Graded Hybrid Composites



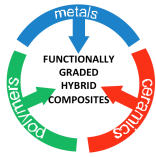

Fuzzy Fibers for Structural Health Monitoring

'Fuzzy' fibers: SiC fiber core with carbon nanotubes grown radially along fiber length

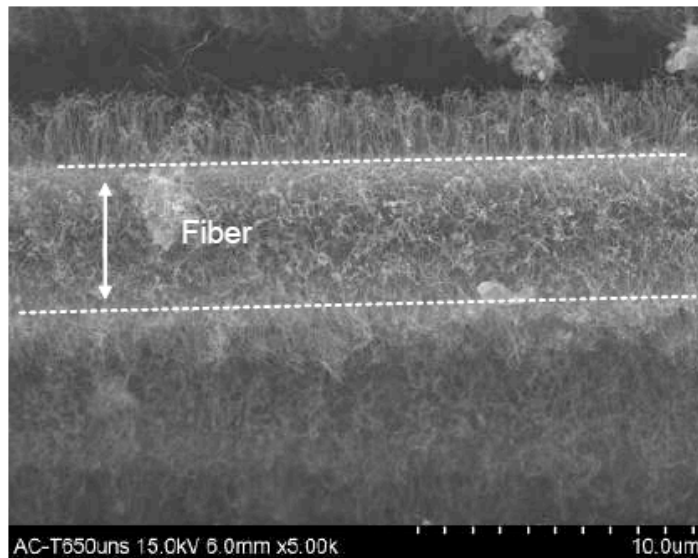

- Predict changes in electromechanical properties with damage evolution within nanocomposite (“fuzzy region”)
- Optimize design of SHM sensors based on fuzzy fibers
- Integrate multiscale model for fuzzy fibers with larger length scale models for FGHC



AFOSR-MURI
Functionally Graded Hybrid Composites



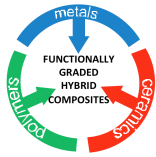

Nanocomposite-based SHM

Key Challenges

Integrate

- molecular dynamics
- finite element analysis
- homogenization techniques

Accounting for

- mechanical and thermal interface effects
- nanoscale effects of electron hopping and interfacial thermal resistance
- polymer damage evolution model in nanocomposite interphase
- electromechanical properties of CNTs and its influence on fuzzy fiber SHM capabilities

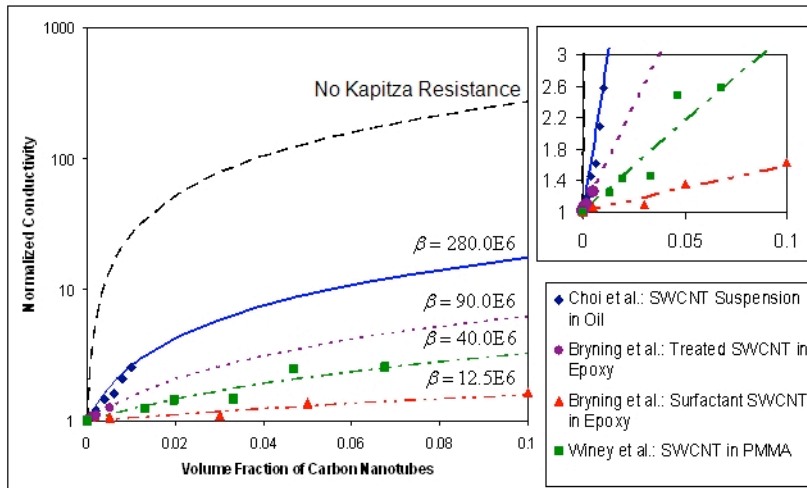
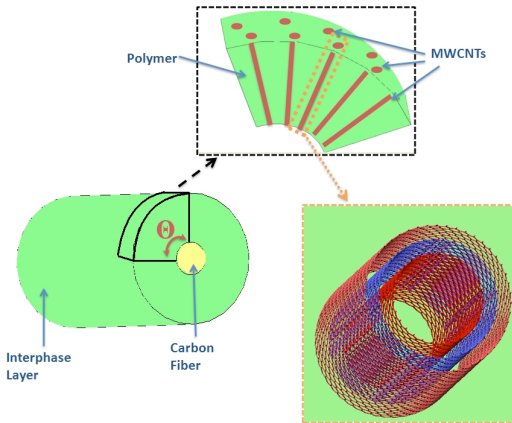

Influence of interfacial thermal resistance on nanocomposite thermal conductivity



AFOSR-MURI
Functionally Graded Hybrid Composites



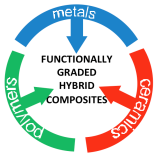

Joints for Complex Material Systems Interfaces

Systems

- **MAX & Hybrid Composite**
- **Metal & TiGr**
- **PMC & Ti**

✓ Base geometric and material heterogeneity in FEA models on microscopy and micro-CT

✓ Include mechanical, thermal, and oxidation effects

✓ Gain insight to damage mechanisms

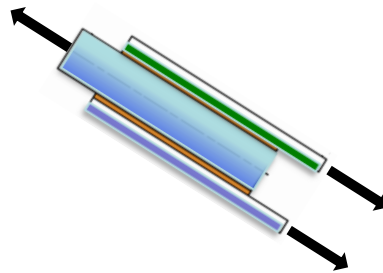
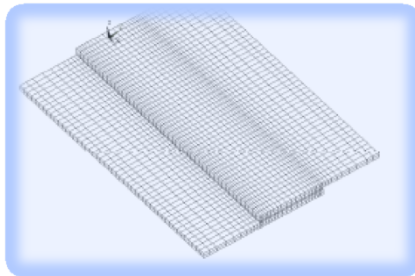

AFOSR-MURI
Functionally Graded Hybrid Composites



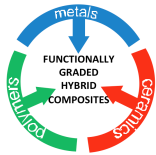

Structural Response

Aero-thermo-elasticity

- Predict aero-thermoelastic response
 - Canonical double-wedged wing
 - Typical hypersonic vehicle
- Evaluate thermal effects on AE response including material degradation
- Assess effect of elastic deformation on aerodynamic heating
- Evaluate impact of inertial effects in pre-flutter aero-thermoelastic analysis



Impact Behavior of FGHC Structures

Develop an efficient computational framework to evaluate bonded joints and FGHC plate and shell type structural components subjected to low velocity impact.



AFOSR-MURI AFOSR-MURI
 Functionally Graded Hybrid Composites



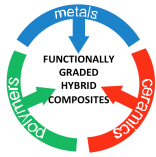

Development and Fabrication Timeline

	6/09-9/09	10/09-1/10	2/10-5/10	6/10-9/10	10/10-1/11	2/11-5/11	6/11-9/11	10/11-1/12	2/12-5/12	Year 4	Year 5
Development of Functionally Graded Hybrid Composites (FGHCs) (Radovic, Karaman, Ounaies, White, Chang, Lafdi, Lagoudas)											
Functionally Graded Ceramic/Metal Composite (GCMcC) Layer						O			E		
Fabricate homogeneous metal infiltrated ceramic preforms	x	x	x	x							
Fabricate functionally graded metal and PZT infiltrated ceramics			x	x	x	x				x	
Self-Cooling Microvascular AC-PMC Layer							O			E	
Sacrificial fiber processing & network optimization	x	x	x	x	x	x					
Weave co-mingled tows for 3D preforms for microvascular composites			x	x	x	x	x	x	x	x	x
High-Temperature Polyimide-Based HT-PMC Layer				O				E			
Processing studies on BMI based polyimide	x	x	x	x	x	x	x		x	x	
Explore fuzzy glass and Sic fibers-fabric reinforcement				x	x	x	x	x	x	x	x
Incorporate self cooling concept									x	x	x
Joining GCMcC and PMC							O			E	
Grow CNTs (nano columns) on interfaces for bonding		x	x	x	x	x	x		x	x	x
Explore metal z-pinning as a joining technique		x	x	x	x	x		x	x	x	x

Note that **O** implies delivery of fabricated specimens and models for 1st generation SHM integrated PMC-AC, PMC-HT, GCMcC, and FGHC where as **E** implies second generation enhancements-lessons learned.



AFOSR-MURI
Functionally Graded Hybrid Composites



56



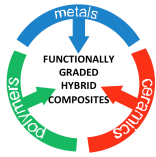

Multi-scale Modeling Timeline

	6/09-9/09	10/09-1/10	2/10-5/10	6/10-9/10	10/10-1/11	2/11-5/11	6/11-9/11	10/11-1/12	2/12-5/12	Year 4	Year 5
Multiscale Modeling FGHCs and Joints (Whitcomb, Reddy, Cizmas, Gao, Lagoudas, Seidel, Geubelle, Inman, Ochoa)											
Design of Material Architectures					O				E		
Micromechanics based modeling of GCMcC	X	X	X	X	X						
Multiscale optimization of AC-PMC and HT-PMC	X	X	X	X	X	X	X	X	X	X	X
Modeling of progressive damage in complex microstructures		X	X	X	X	X	X	X	X	X	X
Multiscale modeling of nanocomposites-based SHM	X	X	X	X	X	X	X	X	X	X	X
Impact behavior of plate and shell FGHC structures				X	X	X	X	X	X	X	X
Aeroelastic modeling of FGHC structural response	X	X	X	X				X	X	X	

*Note that **O** implies delivery of fabricated specimens and models for 1st generation SHM integrated PMC-AC, PMC-HT, GCMcC, and FGHC where as **E** implies second generation enhancements-lessons learned.*



AFOSR-MURI
Functionally Graded Hybrid Composites



57



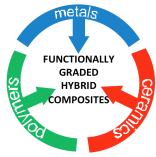

In situ NDE/SHM Timeline

	6/09-9/09	10/09-1/10	2/10-5/10	6/10-9/10	10/10-1/11	2/11-5/11	6/11-9/11	10/11-1/12	2/12-5/12	Year 4	Year 5
In situ NDE/SHM for FGHCs (Chang, Inman, Lafdi, Ounaies, Goulbourne, Seidel)					O					E	
Fabricate polymer film sensor arrays with micro, nano ceramic PZT fillers	x	x	x	x	x	x	x	x			
Fabricate polymer films with aligned & dispersed CNTs for strain sensing		x	x	x	x	x	x	x	x		
Fabricate silicon carbide network to accommodate sensors arrays			x	x	x	x	x	x	x	x	
Develop diagnostics/algorithm		x	x	x	x	x	x	x	x	x	x

*Note that **O** implies delivery of fabricated specimens and models for 1st generation SHM integrated PMC-AC, PMC-HT, GCMcC, and FGHC where as **E** implies second generation enhancements-lessons learned.*



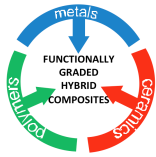

Multi-scale Characterization Timeline

	6/09-9/09	10/09-1/10	2/10-5/10	6/10-9/10	10/10-1/11	2/11-5/11	6/11-9/11	10/11-1/12	2/12-5/12	Year 4	Year 5
Multiscale Characterization of FGHCs (Sottos, Goulbourne, Ochoa, Lafdi, Ounaies, Radovic, Karaman, Lagoudas)											
Obtain Physical and Mechanical Properties of GCMcC and PMC Layers				O				E			
Microstructure and reinforcement architecture interdependence	x	x	x	x	x	x	x	x	x		
Local stress analysis and damage initiation			x	x	x	x	x	x	x	x	x
Thermomechanical and thermo-oxidative capacity		x	x	x					x	x	x
Interfaces and Bonded Joints						O				E	
Evaluate GCMcC/PMC joint shear strength, delamination resistance				x	x	x	x	x	x	x	x
Characterize thermal impedance of FGHC joints						x	x	x	x	x	
Assess integrity of micro-vascular network, sensor arrays			x	x	x	x	x	x	x	x	x
Structural Performance							O				E
Impact response of PMC, GCMcC, FGHCs with SHM network					x	x	x	x	x	x	
Determine modulus and damping parameters of FGHCs							x	x	x	x	

Note that **O** implies delivery of fabricated specimens and models for 1st generation SHM integrated PMC-AC, PMC-HT, GCMcC, and FGHC where as **E** implies second generation enhancements-lessons learned.



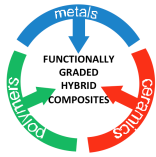

First Annual Program Review

September 23-24, 2010
UDRI Dayton OH

MURI18.TAMU.EDU

oochoa@tamu.edu



AFOSR-MURI
Functionally Graded Hybrid Composites

