

Image Cover Sheet

CLASSIFICATION

SYSTEM NUMBER

139451

UNCLASSIFIED



TITLE

A PERFORMANCE COMPARISON OF THE ILTIS 1/4 T 4X4 TRUCK EQUIPPED WITH
PASSIVE AND ACTIVE SUSPENSION SYSTEMS

System Number:

Patron Number:

Requester:

Notes:

DSIS Use only:

Deliver to: JR

1. The first part of the document discusses the importance of maintaining accurate records of all transactions. This is essential for ensuring the integrity of the financial data and for providing a clear audit trail.

2. The second part of the document outlines the various methods used to collect and analyze data. These methods include direct observation, interviews, and the use of specialized software tools.

3. The third part of the document describes the results of the data collection and analysis. It shows that there is a significant correlation between the variables being studied, which supports the hypothesis.

4. The fourth part of the document discusses the implications of the findings. It suggests that the results could be used to inform policy decisions and to improve the efficiency of the system being studied.

5. The fifth part of the document concludes the study and provides a summary of the key findings. It also identifies some areas for further research and suggests potential future directions.

6. The sixth part of the document provides a detailed description of the methodology used in the study. This includes information about the sample size, the data collection process, and the statistical methods used for analysis.

7. The seventh part of the document discusses the limitations of the study. It acknowledges that there are some potential biases and that the results may not be generalizable to all situations.

8. The eighth part of the document provides a list of references for the sources used in the study. These references include books, articles, and other documents that provide background information and support for the study.

9. The ninth part of the document provides a list of appendices. These appendices contain additional information that is relevant to the study but is not included in the main text, such as raw data and detailed calculations.

10. The tenth part of the document provides a list of figures and tables. These figures and tables are used to present the results of the study in a clear and concise manner, making it easier for the reader to understand the data.

11. The eleventh part of the document provides a list of footnotes. These footnotes provide additional information about the sources used in the study and clarify any points that may be unclear from the main text.

12. The twelfth part of the document provides a list of acknowledgments. These acknowledgments thank the individuals and organizations that provided support and assistance during the course of the study.



National
Defence

Défense
nationale

UNCLASSIFIED

UNLIMITED
DISTRIBUTION

DRES

SUFFIELD MEMORANDUM

NO. 1428

**A PERFORMANCE COMPARISON OF THE ILTIS
1/4 T 4X4 TRUCK EQUIPPED WITH PASSIVE AND
ACTIVE SUSPENSION SYSTEMS (U)**

by

**D.M. Hanna and A.W. McCormac
D.G. Harding and D.R. Fenrick***

***HF Automotive Performance Research Inc.**

February 1994

DEFENCE RESEARCH ESTABLISHMENT SUFFIELD, RALSTON, ALBERTA



Canada

WARNING
"The use of this information is permitted subject to
recognition of proprietary and patent rights".

UNCLASSIFIED

UNLIMITED DISTRIBUTION

DEFENCE RESEARCH ESTABLISHMENT SUFFIELD
RALSTON, ALBERTA

SUFFIELD MEMORANDUM 1428

**A PERFORMANCE COMPARISON OF THE ILTIS 1/4 T 4X4 TRUCK
EQUIPPED WITH PASSIVE AND ACTIVE SUSPENSION SYSTEMS (U)**

by

D.M. Hanna
A.W. McCormac
D.G. Harding*
D.R. Fenrick*

*HF Automotive Performance Research Inc.

December 1993

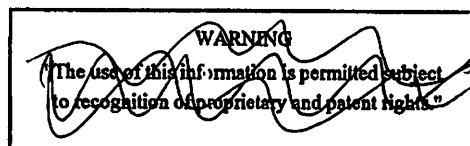

UNCLASSIFIED

ABSTRACT

An active suspension system, which forces the wheels of the vehicle to move up and down in response to the ground profile in order to enhance vehicle mobility, has been developed and fitted on an Iltis 1/4 ton 4X4 military truck. Maximum attainable speeds increased 11 percent in a steady-state turn, 20 percent in a slalom manoeuvre, and a speed increase in excess of 100 percent over bumps was possible while keeping driver accelerations at equivalent levels. The ride is improved, the vehicle is capable of out-performing a passively suspended Iltis in virtually all test conditions attempted, and the vehicle has become virtually impossible to roll over.

The active suspension system is comprised of on-board hydraulics and an electronic control system. The electronic control system regulates motion of the active suspension struts according to a user specified control algorithm. A disturbance rejection algorithm was developed which reads and maintains individual actuator force values at initial levels, thereby providing good ride quality. Stability was enhanced by increasing the downward force on outside wheels in a turn based on body lateral acceleration and actuator force feedback.

Safety and performance are enhanced at the expense of mechanical complexity and a slight drain of engine power. However, the power required to operate the suspension does not hamper vehicle performance. The active suspension system does add mechanical and hydraulic complexity to the vehicle. Consideration of an active suspension system for an in-service CF vehicle must weigh the performance and safety benefits against additional acquisition and life-cycle costs in well defined mission scenarios.

TABLE OF CONTENTS

| | |
|---|----|
| Abstract..... | ii |
| List of Figures..... | iv |
| List of Tables..... | v |
| Background..... | 1 |
| Introduction..... | 1 |
| Purpose..... | 2 |
| Definition of Active Suspension..... | 2 |
| Testbed Vehicle..... | 4 |
| The Active Suspension System..... | 5 |
| Hydraulic System Hardware..... | 5 |
| Control System Hardware..... | 6 |
| Feedback Control..... | 6 |
| Results..... | 8 |
| Off-road Ride Quality..... | 9 |
| Transient Response Over a Single Bump..... | 9 |
| Maximum On-road Speed in a Steady-state Turn..... | 10 |
| Maximum Slalom Speed..... | 11 |
| Safety..... | 13 |
| Conclusions..... | 15 |
| Recommendations..... | 16 |
| References..... | 17 |
| Annex..... | 18 |

LIST OF FIGURES

| | | |
|----|--|----|
| 1. | Iltis 1/4 T 4X4..... | 3 |
| 2. | Schematic of Active Suspension Hydraulic and Electronic Subsystems..... | 5 |
| 3. | Electronic Control System Schematic..... | 7 |
| 4. | Vertical Acceleration vs. Speed Over a Single Bump..... | 10 |

LIST OF TABLES

| | | |
|------|--|----|
| I. | Off-road Ride Quality..... | 9 |
| II. | Transient Response over a Single Bump..... | 10 |
| III. | Measurements in a Steady-state Turn..... | 11 |
| IV. | Measurements in a Slalom Manoeuvre..... | 12 |
| V. | Demonstrated Speed Improvements in Various Dynamic Performance Experiments..... | 13 |
| A.I | Off-road Ride Quality Results..... | 18 |
| A.II | Measurements in a Slalom Manoeuvre..... | 19 |

BACKGROUND

This document constitutes the final report on activities related to a CRAD tasking PM AALV 05 designated 0318N-11 entitled "Active Suspension Systems." This work was initiated by DRES/VCG in 1988 for the Light Armoured Vehicle project. DRES conducts applied R&D in the area of vehicle mobility and was asked to evaluate active suspension technologies for possible military application.

Based on analytical studies in the research literature at that time, it was evident that active suspension systems had a number of potential performance benefits. It was also believed, however, that the drawbacks (namely, the power required and added hardware complexity) were significant enough to render these systems impractical or even unrealizable. In this context, this study was defined to include both analytical and experimental thrusts in an effort to objectively and quantitatively address both concerns.

Although the LAV project itself no longer exists and therefore will not be the direct recipient of this information, this study will be of benefit to other vehicle users in the Canadian Forces or Canadian industry and will most certainly be applied by the Vehicle Concepts Group at DRES to unmanned vehicle developments.

INTRODUCTION

Almost all existing vehicle suspensions are of the passive type. Passive suspension systems respond to road (or off-road) irregularities or handling dynamics in a predictable manner determined by their particular mechanical design. They may return a force proportional to the product of the spring constant and the suspension deflection, and/or dampen a force according to the product of the damper constant and the suspension velocity. However, this only occurs as a result of movement created by the forcing

function, in this case, the terrain over which the vehicle is operating. They do not generate any force of their own.

Passive suspension systems are a design compromise. The ideal suspension system would be one which gives a smooth ride when encountering bumps and rough surfaces but which also provides firm (minimal) response in cornering, particularly at high speeds, and in braking or acceleration situations. This is the classic ride versus handling problem of which many automobile owners and operators, and certainly all manufacturers, are aware. The ride of many large luxury automobiles is desirable whereas the handling characteristics are less than ideal. Conversely, performance automobiles or "sports cars," or many off-road vehicles, display the opposite characteristics, predictable and firm handling characteristics in dynamic situations but a correspondingly firm response to bumps. This transmits more vibration to the driver and occupants and results in a less comfortable ride. Passive suspension designs are, out of necessity, a compromise between these two ideals.

Active suspension systems offer the possibility of overcoming, to a great extent, the ride versus handling trade-offs inherent in passive systems. That is, they are able to produce a smooth ride over road irregularities while simultaneously delivering a firm and controllable response to turning and braking manoeuvres. Of course, the exact nature of active suspension response depends on the capabilities of the hardware and on the complexity and comprehensiveness of the control algorithm which has been implemented. The aim of this study was to develop an active suspension and associated control algorithms to increase overall vehicle mobility performance criteria.

OBJECTIVE

The specific objectives of this study are as follows:

1. to develop and to install a fully active suspension system on an SMP vehicle capable of implementing a variety of control schemes;
2. to investigate a number of different control schemes, then select promising candidates; and
3. to demonstrate and quantify the benefits of active suspensions in on-road and off-road scenarios.

DEFINITION OF "ACTIVE" SUSPENSION

For the purpose of this study, a fully active suspension system is defined as one which provides force input to each of the vehicle's wheels in a manner that permits control of wheel motions to a frequency beyond the wheel-hop frequency, and control of body motions to a frequency at and below the natural frequency of the vehicle's sprung mass. Therefore, such a system is separate and distinct from other so-called active suspension systems which do not enable force input to the suspension assemblies, or systems which input a force or change suspension displacement but do so at low frequencies outside of the region pertinent to vehicle dynamic investigations.

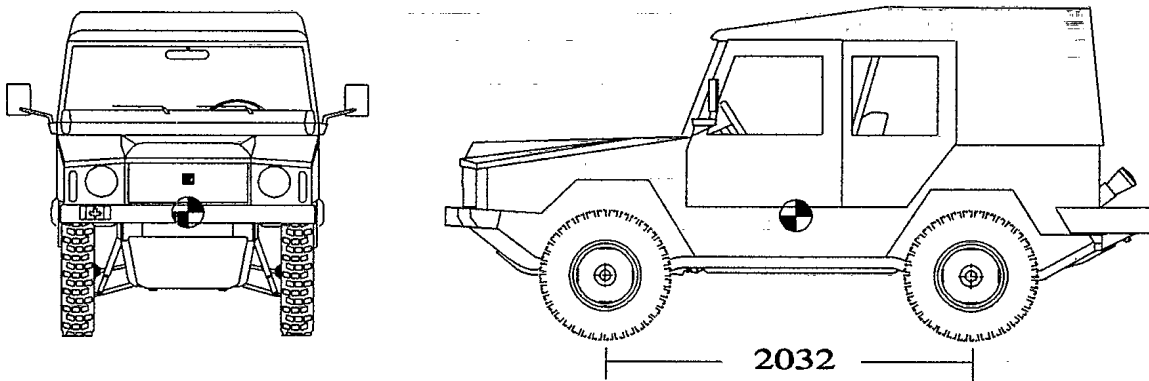

Figure 1
Iltis 1/4 T 4x4

TESTBED VEHICLE

The vehicle selected as the experimental testbed to receive the active suspension system is the standard military pattern Iltis 1/4 ton 4X4 truck (Figure 1). It was chosen for a number of reasons. First of all, it is relatively small and therefore does not require large, and potentially more costly, active components. It has a wheelbase of 2032 mm and weighs 1600 kgf.

Secondly, it has a simple suspension system (Figure 2). The Iltis suspension is fully independent and similar to a double control arm arrangement in that it has a lower control arm. However, the typical upper control arm has been replaced by a transverse leaf spring. The middle of the spring is rigidly attached to the centre of the vehicle's chassis. Opposite ends extend laterally outward to each side and attach to the right and left wheel end assemblies. In this way, it provides the suspension springing force and also doubles as the upper control arm which dictates the path of the wheel end assembly. The springs, shock absorbers, and control arms are dimensionally identical for all four wheels. Therefore, selection of four identical active suspension actuators was possible which further reduced cost and complexity.

Finally, and perhaps most importantly, the passively suspended Iltis in its conventional form possesses good dynamic performance characteristics. It is not as prone to rollover in highway turning or turning/braking manoeuvres as are its 1/4 ton predecessors or many of the current commercial sport utility vehicles of comparable size. At the same time, it possesses quite good off-road or rough road ride quality. This combination of desirable performance characteristics was an important consideration in the selection of a testbed vehicle. If the M151 had been selected as the test vehicle, it could justifiably be argued that any number of changes to its passive suspension would favourably alter its performance. However, in the case of the Iltis vehicle, any

demonstrable performance improvement in these areas can be considered significant when compared to its already highly capable base level of performance.

THE ACTIVE SUSPENSION SYSTEM

The active suspension system as implemented on the Itlis vehicle consists of two subsystems: an high pressure hydraulic system, and an electronic control system.

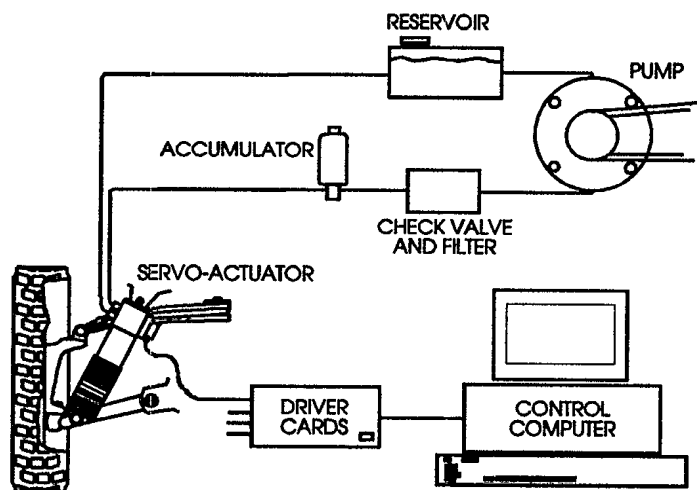

Figure 2

Schematic of Active Suspension Hydraulic and Electronic Subsystems.

Hydraulic System Hardware

The hydraulic system consists of an axial piston pump (.95 litres/sec) driven off of the engine crankshaft by a single v-belt (Figure 2). The pump delivers hydraulic oil (at 15.2 MP) through a flow-control check valve, a safety pilot valve, and an high pressure filter to any of the double-acting servo-actuators at each suspension assembly. Located in-line near each servo-actuator is an accumulator designed to sustain flow in peak demand

situations. The hydraulic flow at the actuator is regulated at high frequency by servo control valves imbedded in each actuator. Supply and return oil flows are accommodated in a hydraulic reservoir which is integral with the front bumper of the vehicle. This allows a sizable hydraulic reservoir without consuming limited free space in the engine bay while, at the same time facilitating cooling of the hydraulic oil.

Control System Hardware

The electronic control system is made up of a number of transducers, an A/D card, an IBM PC compatible control computer, and analog control cards. Force, acceleration, and displacement transducers make vehicle state information available to the A/D card. The A/D card reads the analog signals from all transducers every five milliseconds and presents corresponding digital values to the control computer. The control computer calculates set points (which can either be force or position) for the actuators based on transducer input values according to the user specified control algorithm. The actuator set point, which is updated every five milliseconds, is communicated to the analog control circuitry. The analog control circuitry consists of four analog control cards, one for each servo-actuator, which control the actuators to the set point that has been received from the control computer. The control cards are capable of PID (proportional/integral/derivative) control. Currently, only proportional control is utilized. The system as described above was designed by Queens University. A detailed description of the hydraulic and electronic systems is available in the active suspension design report by Tragenza.[1]

FEEDBACK CONTROL

The control electronics and associated software are configured in a way that easily permits implementation of user specified control algorithms for the active suspension

system. This is done by simply replacing two software files, USER.C and Iltis.CFG. The latter file contains information that specifies which input sensors are to be read, the minimum and maximum voltage values, and the minimum and maximum real values from which scale factors are calculated. USER.C is the C program module that contains the actual control algorithm for experimentation.

During the course of experimental work, a number of different control algorithms were developed, and/or found from research literature, and utilized in experiments. As part of the work performed by Queens University, a passive algorithm was developed which gave the active suspension system the capability to emulate Iltis passive suspension characteristics. Queens implemented a displacement-based full state estimator control algorithm based on quarter-car modelling done by Yue et al.[2] They also developed a force-based disturbance rejection algorithm which, after initially reading the vehicle start-up state, simply attempts to maintain individual actuator force values at initial levels.

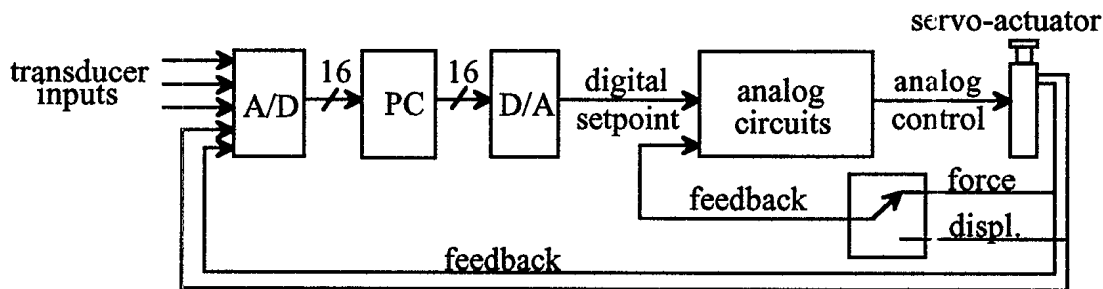

Figure 3

Electronic System Schematic

The disturbance rejection algorithm provided the basis for the experiments reported herein. The disturbance rejection algorithm, which provides good ride quality, was modified to change the set point of the actuators of "outside" wheels in turning manoeuvres based on body lateral acceleration and actuator force feedback (Figure 3). In

this way, the downward force was increased on outside wheels and decreased on inside wheels. This has the effect of significantly reducing body roll and increasing vehicle stability while maintaining improved ride quality. The results of performance experiments utilizing this control algorithm are reported hereafter.

RESULTS

In order to provide a reasonable basis for performance comparisons, the following four types of experiments were conducted using both a passive Iltis vehicle and the active suspension test vehicle:

1. ride quality on off-road,
2. transient response over a single bump,
3. maximum on-road speed in a steady-state turn , and
4. maximum slalom speed.

Regardless of the type of experiment being conducted, eight channels of data were measured for each experiment:

1. vehicle speed,
2. body pitch angle,
3. body roll angle,
4. body angular pitch rate,
5. body angular roll rate,
6. body angular yaw rate,
7. lateral acceleration of the vehicle centre of gravity, and
8. vertical acceleration of the vehicle centre of gravity.

In addition, a minimum of two (and often as many as four) replications of each type of experiment were performed. The results of these experiments are recorded in the Annex of this report and are summarized below.

Off-road Ride Quality

Off-road ride quality experiments were conducted by driving the testbed vehicle at constant speed along a straight-line off-road course approximately 100 meters in length. Several speeds were selected between 10 and 60 kilometers per hour depending on course severity. The vertical acceleration time-history for each experiment was analyzed with an absorbed power spectrum filter, the results of which are summarized in Table I. The absorbed power filter performs a frequency weighting of the magnitude of the vertical accelerations, which approximates an eight hour exposure level under ISO 2631, and gives a single value which represents the vibrational energy experienced by the vehicle occupant.

| | Absorbed Power (Watts) | |
|---------------|-------------------------|-------------------------|
| | smooth off-road terrain | medium off-road terrain |
| passive | 0.014 | 0.087 |
| active | 0.012 | 0.079 |
| % improvement | 15.0 | 10.0 |

Table I
Off-road Ride Quality

Transient Response Over a Single Bump

A transient response experiment was performed by driving the vehicles at constant speed over a single bump placed on a level surface. Speeds between 10 and 50 kilometers per hour were selected depending on the severity of vehicle response. Results are reported at 20, 30 and 40 kilometers per hour for a rectangular bump 7.5 cm high and 9 cm long. In this case, the maximum vertical acceleration gives a good indication of the ride severity or, in other words, the degree to which the suspension is able to attenuate the bump. These results are summarized in Table II. It can be seen that the vertical acceleration is reduced by 28, 7, and 20 percent for speeds of 20, 30, and 40 kilometers per hour respectively.

| 7.5 cm Bump | Vertical Acceleration (g's) | | |
|-------------|-----------------------------|----------|----------|
| | 20 km/hr | 30 km/hr | 40 km/hr |
| passive | 1.4 | 1.4 | 1.5 |
| active | 1.0 | 1.3 | 1.2 |
| % reduction | 28.0 | 7.0 | 20.0 |

Table II

Transient Response Over a Single Bump

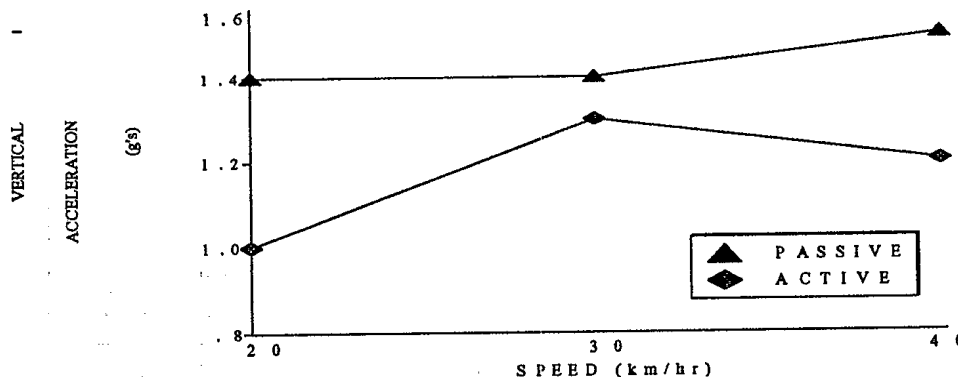

Figure 4

Vertical Acceleration vs. Speed Over a Single Bump

However, the truly significant difference between these situations becomes evident in the graph of Figure 4. Since, over the speeds observed, the acceleration curve for the active vehicle never reaches the lowest value of acceleration experienced by the passive vehicle, it is evident that this represents a speed increase in excess of 100 percent for the same level of passenger comfort. It must be remembered, however, that these are relatively low levels of vertical acceleration which are well within the comfort range for the human driver. It could reasonably be expected that speed increases near the maximum acceptable level of 2.5 g's would be less than those observed at these speeds.

Maximum On-road Speed in a Steady-state Turn

In an attempt to derive some indication of road-holding performance, steady-state turning experiments were devised where the vehicles were driven in a circle of prescribed diameter. The aim of these experiments was to determine and compare the maximum attainable speed, and to note the corresponding body roll angle. Table III shows an achievable speed increase of 11 percent with a corresponding 70 percent reduction in body roll.

| | Turn Radius (18 m) | |
|------------------|--------------------------|-------------------------|
| | velocity (km/h) | roll angle (degrees) |
| passive | 45.0 | 10.0 |
| active | 50 | 3.0 |
| % improvement | 11.0 | 70.0 |

Table III

Measurements in a Steady-state Turn

Maximum Slalom Speed

Experiments conducted to determine the maximum slalom speed were included in order to assess transient control provided by both suspension systems. The slalom course consists of a series of cones placed in a straight line spaced approximately 17 meters apart. The experiments were conducted by driving the vehicle at constant speed down the length of the course and taking alternate cones on the right and left sides of the vehicle. A number of attempts are normally required for any given course configuration before being able to determine the maximum achievable speed. The results of these experiments are summarized in Table IV.

| | Cone Spacing (17 m) | | |
|---------------|------------------------|--------------------------|---------------------|
| | yaw rate (deg/s) | maximum speed (km/hr) | roll angle (deg) |
| passive | +/-2.5 | 41.0 | +4, -6 (10) |
| active | +/-4.1 | 49.0 | +1.5, -4 (5.5) |
| % improvement | 64.0 | 20.0 | 45.0 |

Table IV

Measurements in a Slalom Manoeuvre

It is interesting to observe that, even though the speed is 20 percent greater for the active vehicle, the roll angle is reduced by 45 percent. The speed increase is partly due to this fact but also aided by the increased yaw rate possible while still maintaining control of the vehicle through the length of the course. Further, the speed increase alone gives no indication of the subjective feeling of the driver or occupants who universally prefer the

more secure feeling of operation under conditions of reduced roll angle even though at significantly greater speed.

The following table summarizes the speed increases achieved in the various areas of vehicle dynamic performance for which experiments were performed. Although it can be seen that the magnitude of improvements in dynamic performance vary quite widely, the most important observation is that performance is improved in all areas, for both ride comfort and stability situations which, for passive suspensions, was unable to be satisfied.

| | Passive | Active | % Increase |
|-------------------|---------|--------|------------|
| Obstacles | 20.0 | 40.0 | 100+ |
| Steady-state Turn | 45.0 | 50.0 | 11.0 |
| Slalom | 41.0 | 49.0 | 20.0 |

Table V

Demonstrated Speed Improvements in Various Dynamic Performance Experiments

SAFETY

Since significant speed increases are possible, one must consider the possibility of a system failure and its consequences. In the event of failure of the control computer, the vehicle reverts to simple disturbance-rejection control without body roll control. This gives stability response equal to the passive vehicle but delivers the same ride comfort as the active suspension. In the event of a complete electronic or hydraulic failure, suspension response under all operating conditions is degraded to the same level as the passive vehicle. An electronic or hydraulic failure while operating over rough off-road terrain would result in a much more uncomfortable ride but would pose no physical threat to occupants provided that standard vehicle safety procedures are being followed. An electronic or hydraulic failure under severe body roll conditions (i.e. in a tight turn) could

be considered worst case. If operation at this point were within the normal operating capability of the passive suspension, the result would be a sudden increase in body roll angle. If the operating conditions were beyond the normal capability of the passive suspension, vehicle roll-over would be the result.

This brings out a key issue in the debate regarding the safety of active suspension systems. Will the drivers of vehicles with active suspension operate those vehicles closer to the limit of stable performance? Are they less able to detect where the roll-over point is located? Are they doing so more frequently than in passive vehicles, the result of which is reduced safety overall? The subjective assessment of the authors of this report (all of whom have operated the active test vehicle) is that none of the above are valid concerns and, in fact, the opposite is true.

First, the limit of stable vehicle performance is extended much beyond that of the passive vehicle and renders the active vehicle all but impossible to overturn. Vehicle roll-over never occurred with the active vehicle under operating conditions considerably more severe than those reported in this document. This is not to say that active vehicle roll-over is impossible, because all possible conditions were not attempted. Contrast this situation, however, with common knowledge regarding the stability performance of sport utility vehicles and military trucks such as the Iltis. These vehicles are somewhat prone to roll-over.[3] It seems that the drivers of these vehicles are very easily able to reach and exceed the stability limit. If the failure of an active suspension vehicle results in roll-over under conditions where the passive vehicle would also, then the system is more safe than a passive vehicle because it prevents roll-overs where a system failure does not occur.

The active suspension vehicle would be less safe only where a failure causes roll rate in excess of that caused by the vehicle manoeuvre alone and where roll-over of the passive vehicle is imminent. In this situation, it is possible that the combined effect may exceed the level experienced by a passive vehicle performing an identical manoeuvre.

CONCLUSIONS

A functional and fully active suspension system has been realized in hardware and fitted to an Iltis 4X4 1/4 ton truck. Safety and performance are simultaneously enhanced. The stability envelope is greatly extended, to the point where the vehicle is virtually impossible to roll over. This is a significant safety advantage. Performance improvements in both ride comfort and chassis stability have been demonstrated for the experimental vehicle equipped with active suspension. Indeed, the most significant information to note is the speed increase possible in any of the given situations (summarized in Table V) as this is most relevant to the military context. The vehicle is capable of out-performing a passively suspended Iltis in virtually all test conditions attempted. In many situations, comparisons of experiments performed under identical conditions are not possible because the passive vehicle was simply unable to perform at the same level as the active suspension vehicle.

Safety and performance are enhanced at the expense of mechanical complexity and a drain of engine power. The power required to operate the suspension system ranges from 5 to 10 horsepower, depending on severity of operation.[1] Ten horsepower would be required to traverse severe off-road terrain. Five horsepower represents a nominal operating level. This is significantly less horsepower than early researchers believed would be required by an active suspension system. Moreover, it can be seen from the active suspension presented here (which was designed to optimize ride and stability), that an alternative design is possible which, through a regenerative approach, conserves engine power rather than drawing upon it. In this case, it would be at the expense of vehicle ride quality. At this point, it is sufficient to conclude that the power required to operate the suspension system does not hamper vehicle performance. Rather, it enables significant performance gains.

The active suspension system does add mechanical and hydraulic complexity to the vehicle. Consideration of an active suspension system for an in-service vehicle must

weight the performance and safety benefits against additional acquisition and life cycle costs in well defined mission scenarios.

RECOMMENDATIONS

Several recommendations are offered for consideration. First, a more comprehensive performance comparison over a specific route or one which is based upon a specific mission profile may provide more meaningful results for specific vehicles than merely comparing speed increase in different operating modes as was done for this report. In this way, results from the testbed vehicle could be used to make inferences about the potential benefits of active suspension systems on other wheeled vehicles. Mission profiles are specific to each vehicle type. To undertake an analysis of multiple mission profiles was beyond the scope of this report and the task.

Second, the benefits of active suspension in areas other than human ride comfort would prove to be a worthwhile investigation. For example, active suspension systems are capable of providing platform stabilization for vehicles mounting weapons systems or may be effectively applied to specialty vehicles requiring radically different suspension characteristics from one operating mode to another (such as an earthmover with high speed road capability for the military engineers). The potential to improve vehicle safety in another area that merits additional study.

Third, a previewing system which is able to map the terrain elevation immediately before the wheels would provide a means of further improving the performance of the active suspension system.

Finally, since the control of an active suspension system involves many sensor inputs and computation of a complex control algorithm, this is a technology area where the benefits of neural networks may be exploited. DRES has initiated work in this area.[4]

REFERENCES

1. Tragenza, J.E., "Active Suspension Conceptual Design Report," Dynamics Laboratory, Queen's University, Kingston, Ontario. November, 1988.
2. Yue, C., Butsuen, T., and Hedrick, J.K., "Alternative Control Laws for Automotive Active Suspensions." *Journal of Dynamic Systems, Measurement, and Control*, Vol. 111/287. June, 1989.
3. Anderson, R.J., "Dynamics of Small Four-wheel Drive Vehicles: A Survey of the Literature." Dynamics Laboratory, Department of Mechanical Engineering, Queen's University, Kingston, Ontario. October, 1987.
4. Armstrong, W., "Study of Neural Network Control of an Active Suspension System." Dendronics Decisions Ltd., Edmonton, Alberta. September, 1993.

ANNEX

Results of Ride Quality Experiments on Off-road Terrain

| | Absorbed Power (Watts) | | |
|---------|------------------------|--------|--------|
| | speed | smooth | medium |
| passive | 30.0 | 0.017 | 0.078 |
| | 40.0 | 0.01 | 0.073 |
| | 50.0 | 0.016 | 0.068 |
| | 60.0 | 0.012 | 0.128 |
| active | 30.0 | 0.013 | 0.051 |
| | 40.0 | 0.01 | 0.098 |
| | 50.0 | 0.012 | 0.070 |
| | 60.0 | 0.012 | 0.097 |

Table A.I
Off-road Ride Quality Results

Results of Maximum Slalom Speed Experiments

| | Cone Spacing (17 m) | | |
|------------------|------------------------|-----------------------------|---------------------|
| | yaw rate (deg/s) | vehicle speed (km/hr) | roll angle (deg) |
| passive | +/- 2.5 | 40 | +4.0 -5.5 |
| | +/- 2.5 | 41.0 | +4.0 -6.0 |
| | +/- 2.5 | 42.0 | +4.0 -6.0 |
| average | +/- 2.5 | 41.0 | +4.0 -6.0 |
| active | +/- 4.0 | 48.0 | +1.0 -4.0 |
| | +/- 4.2 | 50.0 | +2.0 -4.0 |
| average | +/- 4.1 | 49.0 | +1.5 -4.0 |
| % improvement | 64.0 | 20.0 | 45.0 |

Table A.II

Measurements in a Slalom Manoeuvre

SECURITY CLASSIFICATION OF FORM
(highest classification of Title, Abstract, Keywords)

DOCUMENT CONTROL DATA

(Security classification of title, body of abstract and indexing annotation must be entered when the overall document is classified)

| | | | |
|---|--|--|---|
| 1. ORIGINATOR (the name and address of the organization preparing the document. Organizations for whom the document was prepared, e.g. Establishment sponsoring a contractor's report, or tasking agency, are entered in section 8.) Defence Research Establishment Suffield P.O. Box 4000 Medicine Hat, Alberta T1A 8K6 | | 2. SECURITY CLASSIFICATION (overall security classification of the document including special warning terms if applicable) Unclassified | |
| 3. TITLE (the complete document title as indicated on the title page. Its classification should be indicated by the appropriate abbreviation (S,C,R or U) in parentheses after the title.) A Performance Comparison of the Iltis 1/4 T 4X4 Truck Equipped With Passive and Active Suspension Systems (U) | | | |
| 4. AUTHORS (Last name, first name, middle initial. If military, show rank, e.g. Doc, Maj. John E.) Hanna, Doug M., McCormac, Allan M., Harding, David G., Fenrick, Dennis R. | | | |
| 5. DATE OF PUBLICATION (month and year of publication of document) FEBRUARY 1994 | | 6a. NO. OF PAGES (total containing information. Include Annexes, Appendices, etc.) 19 | 6b. NO. OF REFS (total cited in document) 4 |
| 6. DESCRIPTIVE NOTES (the category of the document, e.g. technical report, technical note or memorandum. If appropriate, enter the type of report, e.g. interim, progress, summary, annual or final. Give the inclusive dates when a specific reporting period is covered.) Suffield Memorandum, Final Report. | | | |
| 8. SPONSORING ACTIVITY (the name of the department project office or laboratory sponsoring the research and development. Include the address.) DND/CRAD/DRDL, National Defence Headquarters, Constitution Building, 305 Rideau Street, Ottawa, Ontario K1A 0K2 | | | |
| 9a. PROJECT OR GRANT NO. (if appropriate, the applicable research and development project or grant number under which the document was written. Please specify whether project or grant) CRAD Tasking 0318N-11 | | 9b. CONTRACT NO. (if appropriate, the applicable number under which the document was written) | |
| 10a. ORIGINATOR'S DOCUMENT NUMBER (the official document number by which the document is identified by the originating activity. This number must be unique to this document.) Suffield Memorandum 1428 | | 10b. OTHER DOCUMENT NOS. (Any other numbers which may be assigned this document either by the originator or by the sponsor) | |
| 11. DOCUMENT AVAILABILITY (any limitations on further dissemination of the document, other than those imposed by security classification) <input checked="" type="checkbox"/> Unlimited distribution <input type="checkbox"/> Distribution limited to defence departments and defence contractors; further distribution only as approved <input type="checkbox"/> Distribution limited to defence departments and Canadian defence contractors; further distribution only as approved <input type="checkbox"/> Distribution limited to government departments and agencies; further distribution only as approved <input type="checkbox"/> Distribution limited to defence departments; further distribution only as approved <input type="checkbox"/> Other (please specify): | | | |
| 12. DOCUMENT ANNOUNCEMENT (any limitation to the bibliographic announcement of this document. This will normally correspond to the Document Availability (11). However, where further distribution (beyond the audience specified in 11) is possible, a wider announcement audience may be selected.) | | | |

13. **ABSTRACT** (a brief and factual summary of the document. It may also appear elsewhere in the body of the document itself. It is highly desirable that the abstract of classified documents be unclassified. Each paragraph of the abstract shall begin with an indication of the security classification of the information in the paragraph (unless the document itself is unclassified) represented as (S), (C), (R), or (U). It is not necessary to include here abstracts in both official languages unless the text is bilingual).

The purpose of this task was to develop a fully active suspension system for a CF vehicle and to implement a variety of control schemes in order to demonstrate the benefits of this technology. An active suspension system has been developed and fitted on an Iltis 1/4 ton 4X4 military truck. The vehicle has on-board hydraulics and an electronic control system. The hydraulic system consists of a reservoir and an engine-driven pump which supplies oil (15.2 MP) to accumulators and servo-actuators at each suspension assembly. The electronic control system is made up of transducers, an A/D card, a control computer, and analog control cards. The control computer calculates set points for the actuators, based on transducer input values, according to user specified control algorithms.

A disturbance rejection algorithm was developed which reads and maintains individual actuator force values at initial levels, thereby providing good ride quality. Stability was enhanced by increasing the downward force on outside wheels in a turn based on body lateral acceleration and actuator force feedback. The vehicle is capable of outperforming a passively suspended Iltis in virtually all test conditions attempted. Maximum attainable speeds increased by 11 percent in a steady-state turn, 20 percent in a slalom manoeuvre, and a speed increase in excess of 100 percent was possible while keeping driver accelerations at equivalent levels.

The active suspension system does add mechanical and hydraulic complexity to the vehicle. Consideration of an active suspension system for an in-service CF vehicle must weight the performance benefits against additional acquisition and life-cycle costs in well defined usage and mission scenarios.

14. **KEYWORDS, DESCRIPTORS or IDENTIFIERS** (technically meaningful terms or short phrases that characterize a document and could be helpful in cataloguing the document. They should be selected so that no security classification is required. Identifiers, such as equipment model designation, trade name, military project code name, geographic location may also be included. If possible keywords should be selected from a published thesaurus. e.g. Thesaurus of Engineering and Scientific Terms (TEST) and that thesaurus-identified. If it is not possible to select indexing terms which are Unclassified, the classification of each should be indicated as with the title.)

vehicle
vehicle dynamics
active suspension
off-road
ride quality

139451
94-01185