

REPORT DOCUMENTATION PAGE

Form Approved
OMB No. 0704-0188

Public reporting burden for this collection of information is estimated to average 1 hour per response, including the time for reviewing instructions, searching existing data sources, gathering and maintaining the data needed, and completing and reviewing this collection of information. Send comments regarding this burden estimate or any other aspect of this collection of information, including suggestions for reducing this burden to Department of Defense, Washington Headquarters Services, Directorate for Information Operations and Reports (0704-0188), 1215 Jefferson Davis Highway, Suite 1204, Arlington, VA 22202-4302. Respondents should be aware that notwithstanding any other provision of law, no person shall be subject to any penalty for failing to comply with a collection of information if it does not display a currently valid OMB control number. **PLEASE DO NOT RETURN YOUR FORM TO THE ABOVE ADDRESS.**

1. REPORT DATE (DD-MM-YYYY) February 2012		2. REPORT TYPE Viewgraph		3. DATES COVERED (From - To) February 2012- April 2012	
4. TITLE AND SUBTITLE Non-Reactive Shear-Coaxial Jets with and without Transverse Acoustic Forcing				5a. CONTRACT NUMBER In-House	
				5b. GRANT NUMBER	
				5c. PROGRAM ELEMENT NUMBER	
6. AUTHOR(S) Sophonias Teshome				5d. PROJECT NUMBER	
				5e. TASK NUMBER	
				5f. WORK UNIT NUMBER 23080533	
7. PERFORMING ORGANIZATION NAME(S) AND ADDRESS(ES) Air Force Research Laboratory (AFMC) AFRL/RQRC 10 E. Saturn Blvd. Edwards AFB CA 93524-7680				8. PERFORMING ORGANIZATION REPORT NO.	
9. SPONSORING / MONITORING AGENCY NAME(S) AND ADDRESS(ES) Air Force Research Laboratory (AFMC) AFRL/RQR 5 Pollux Drive Edwards AFB CA 93524-7048				10. SPONSOR/MONITOR'S ACRONYM(S)	
				11. SPONSOR/MONITOR'S REPORT NUMBER(S) AFRL-RZ-ED-VG-2012-125	
12. DISTRIBUTION / AVAILABILITY STATEMENT Distribution A: Approved for Public Release; Distribution Unlimited. PA#12271					
13. SUPPLEMENTARY NOTES Ph.D. Defense, UCLA, Los Angeles, CA 23 April 2012					
14. ABSTRACT <p>This research has concentrated on the characterization of mixing for typical liquid rocket injectors. The conditions of interest have encompassed subcritical to supercritical pressures with temperatures below and above the critical temperature, with and without an acoustic field. The project has been largely experimental in-house. A single shear coaxial injector element has been thoroughly studied. This type of injector element is commonly used in many rocket engines (e.g., Space Shuttle Main Engine (SSME), Vulcain, RS-68, etc). It was found that the mixing in these injectors is governed primarily by the presence or absence of an acoustic field, the outer to inner jet area ratio and the inner jet lip thickness to inner jet diameter, the outer to inner momentum flux ratio, the reduced density of the inner jet, and on whether the pressure is subcritical and supercritical.</p>					
15. SUBJECT TERMS					
16. SECURITY CLASSIFICATION OF:			17. LIMITATION OF ABSTRACT SAR	18. NUMBER OF PAGES 66	19a. NAME OF RESPONSIBLE PERSON Doug Talley
a. REPORT Unclassified	b. ABSTRACT Unclassified	c. THIS PAGE Unclassified			19b. TELEPHONE NO (include area code) 661-275-6174

Non-Reactive Shear-Coaxial Jets with and without Transverse Acoustic Forcing

Sophonias Teshome

University of California, Los Angeles
Department of Mechanical and Aerospace Engineering

Ph.D. Thesis Defense

April 23, 2012



Motivation

- Feedback cycle between liquid rocket engine (LRE) combustion chamber pressure perturbations and unsteady combustion^{1,2}
- Large amplitude fluctuations in pressure and combustion heat release rates \Rightarrow combustion instability



¹Harrje, D.T., and Reardon, F.H.. *Scientific and Technical Information Office*, National Aeronautics and Space Administration, NASA SP-194, 1972.

²Schadow, K.C., Gutmark, E., Parr, T.P., Parr, D.M., Wilson, K.J., and Crump, J.H.. *19th AIAA Fluid Dynamics, Plasma Dynamics and Lasers Conference*, AIAA 1987-1326



Objective

- Impose external acoustic perturbations, and examine the response and stability characteristic of shear-coaxial injector flow to pressure perturbation

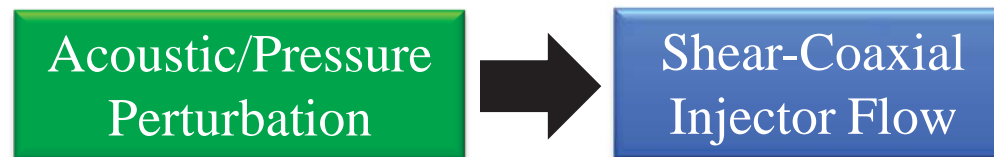

- Investigate influence of injector geometry on flow response to external pressure perturbation
- Vary the outer-to-inner jet momentum flux ratio, J , under subcritical chamber pressure condition, i.e., reduced pressure $Pr = 0.44, 1.05$

$$J = \frac{\rho_o u_o^2}{\rho_i u_i^2} \quad Pr = \frac{P_{chamber}}{P_{critical, N_2}} \quad P_{critical, N_2} = 3.4 \text{ MPa (493 psi)}$$

- Characterize mixing using dark-core length measurements
- Apply proper orthogonal decomposition of high-speed image pixel intensity fluctuations to extract spatial and temporal characteristics of prevalent coherent flow structures



Schematic of Experimental Facility

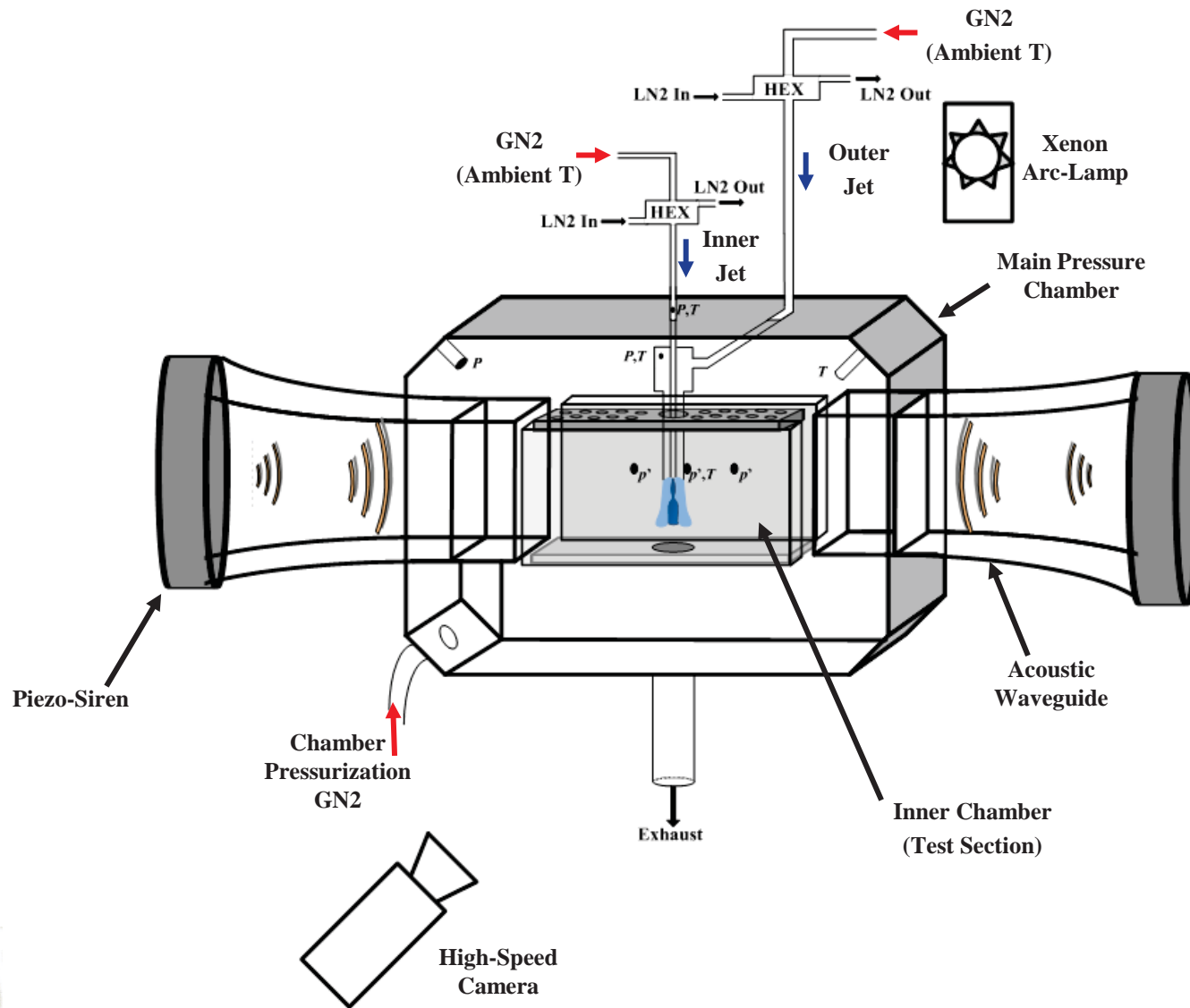
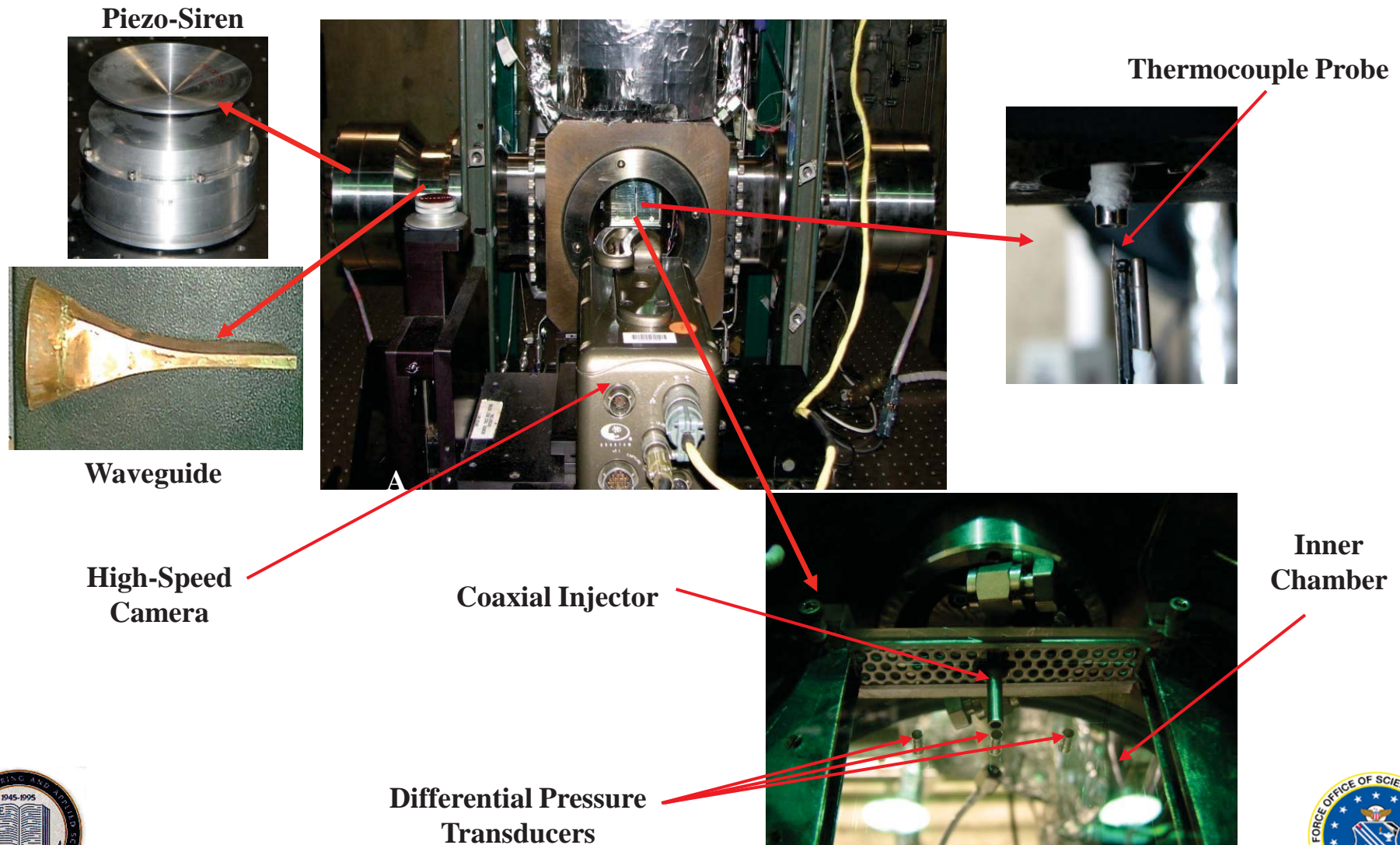
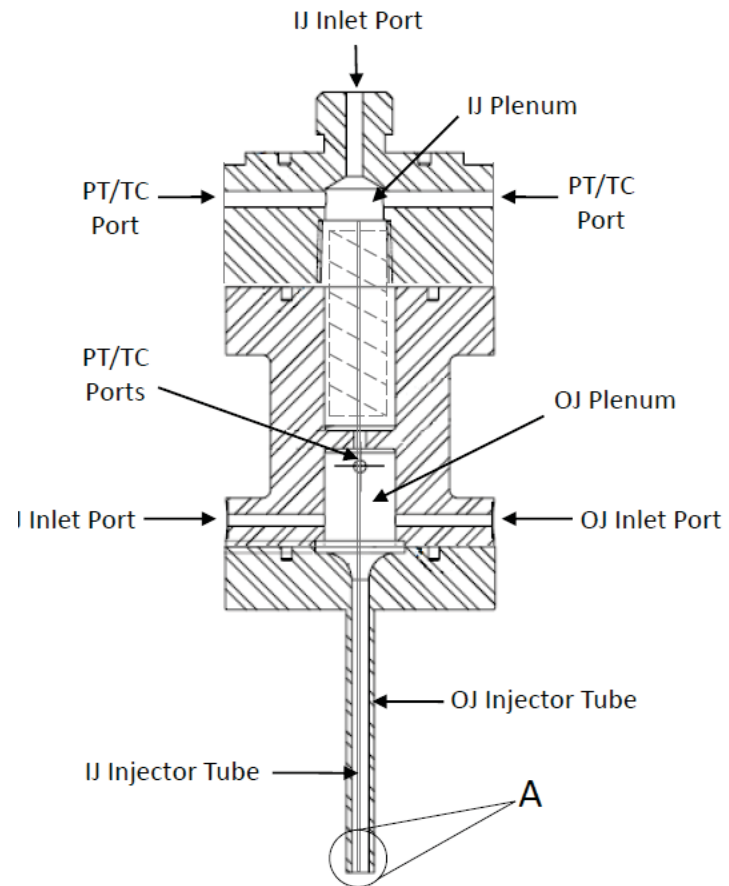
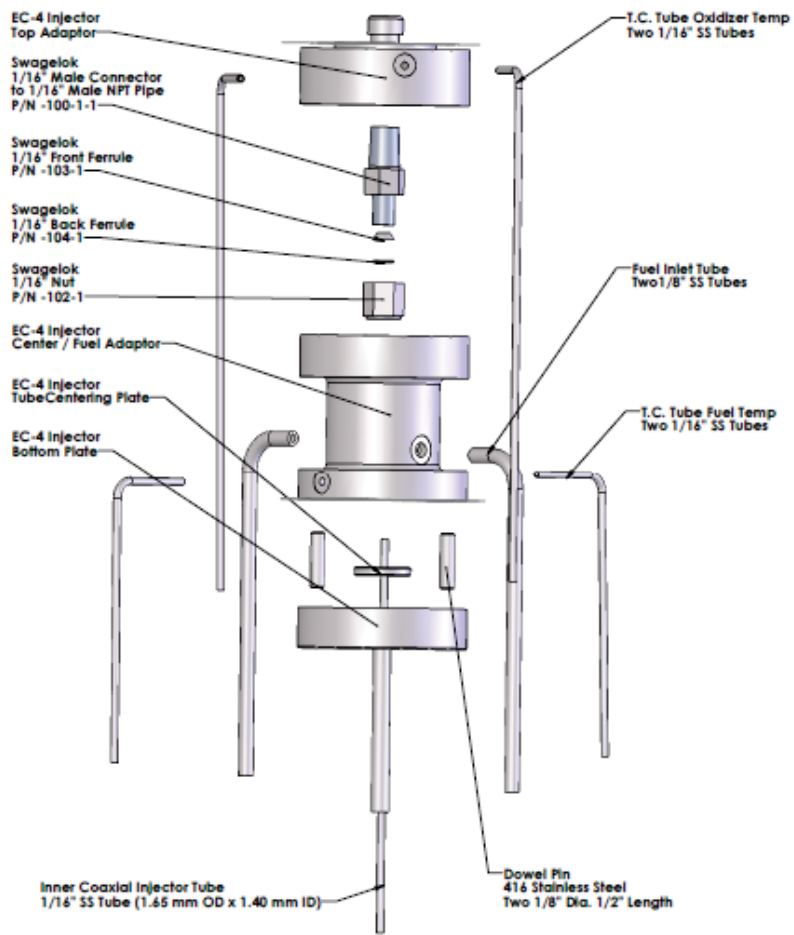

Image of Experimental Facility



Injector Assembly



Injector Configuration

- Two types of outer-to-inner jet cross-sectional area ratios
 - Large Area Ratio, thin post (LAR-thin)
 - Small Area Ratio, thick post (SAR-thick)

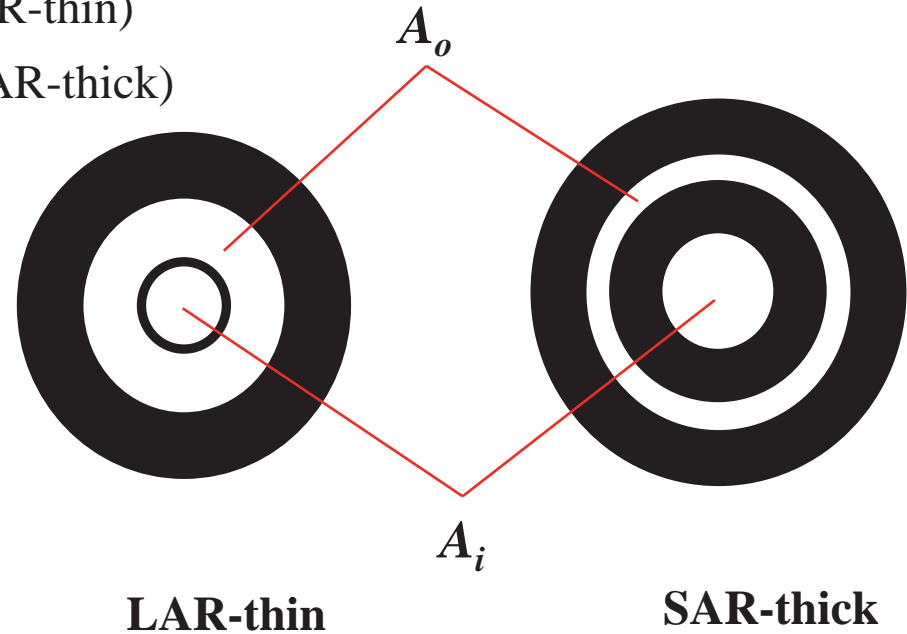
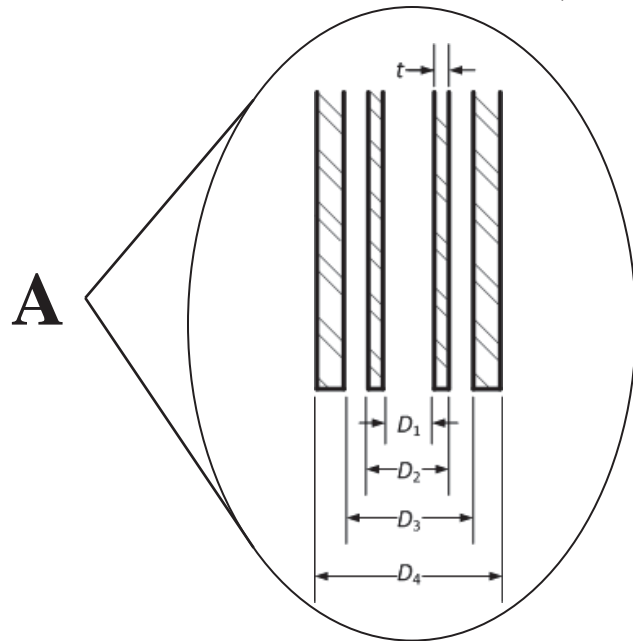

All dimensions in mm

Injector	D_1	D_2	D_3	D_4	t/D_1	A_o/A_i
LAR-thin	0.70	0.89	2.44	3.94	0.13	10.6
SAR-thick	1.47	3.96	4.70	6.35	0.84	2.90



Waveguides

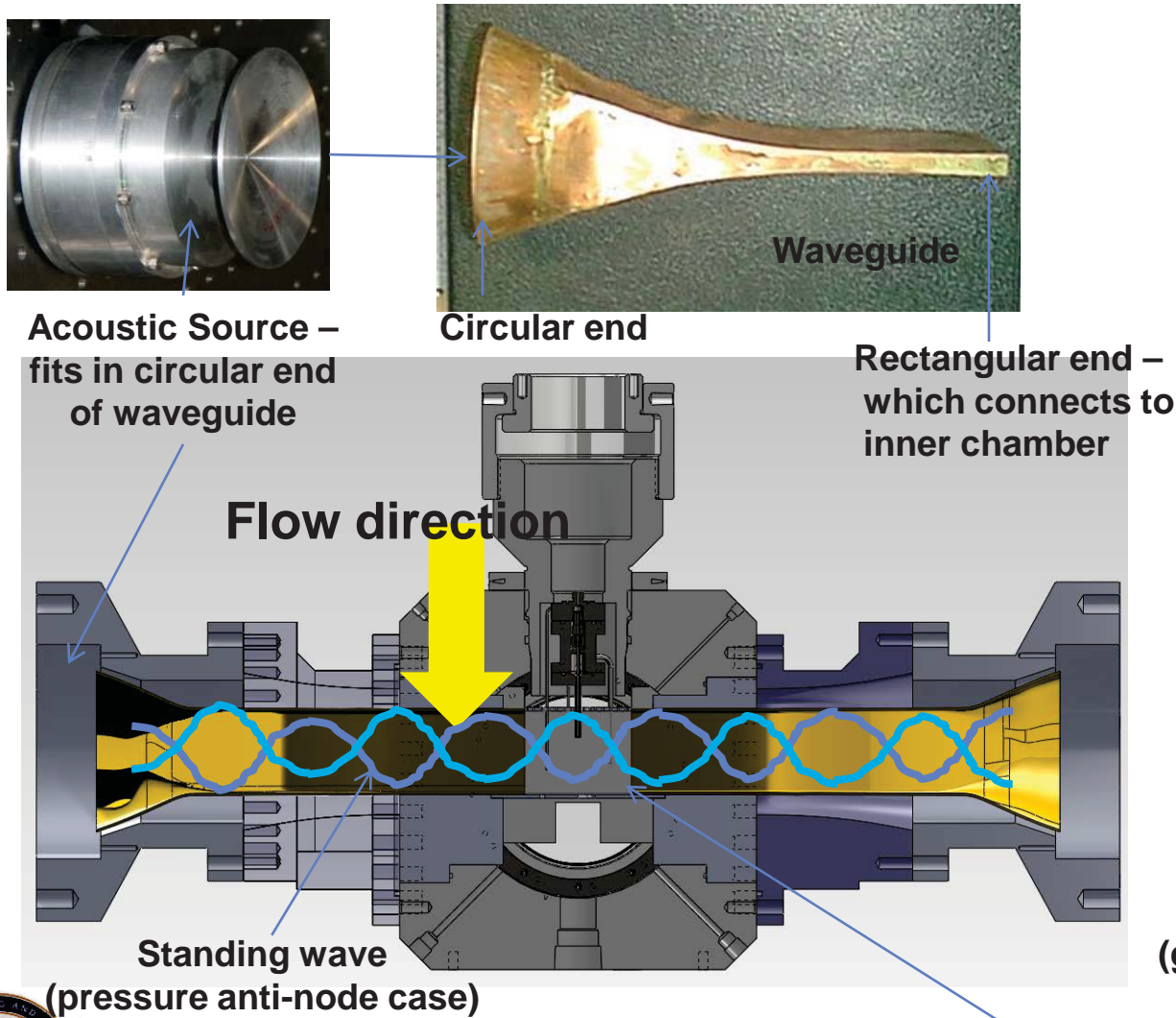

Waveguide viewed from side (going from round to rectangular cross section)



Waveguides viewed the front - cross section

Inner Chamber



Acoustic Field Set-Up: Pressure Antinode

- Pressure antinode (PAN) – condition of maximum pressure perturbation in the acoustic field
- Piezo-sirens forced in-phase
- Superposition of quasi-1D acoustic waves traveling in opposite directions \Rightarrow PAN at the jet location (geometric center of test section)

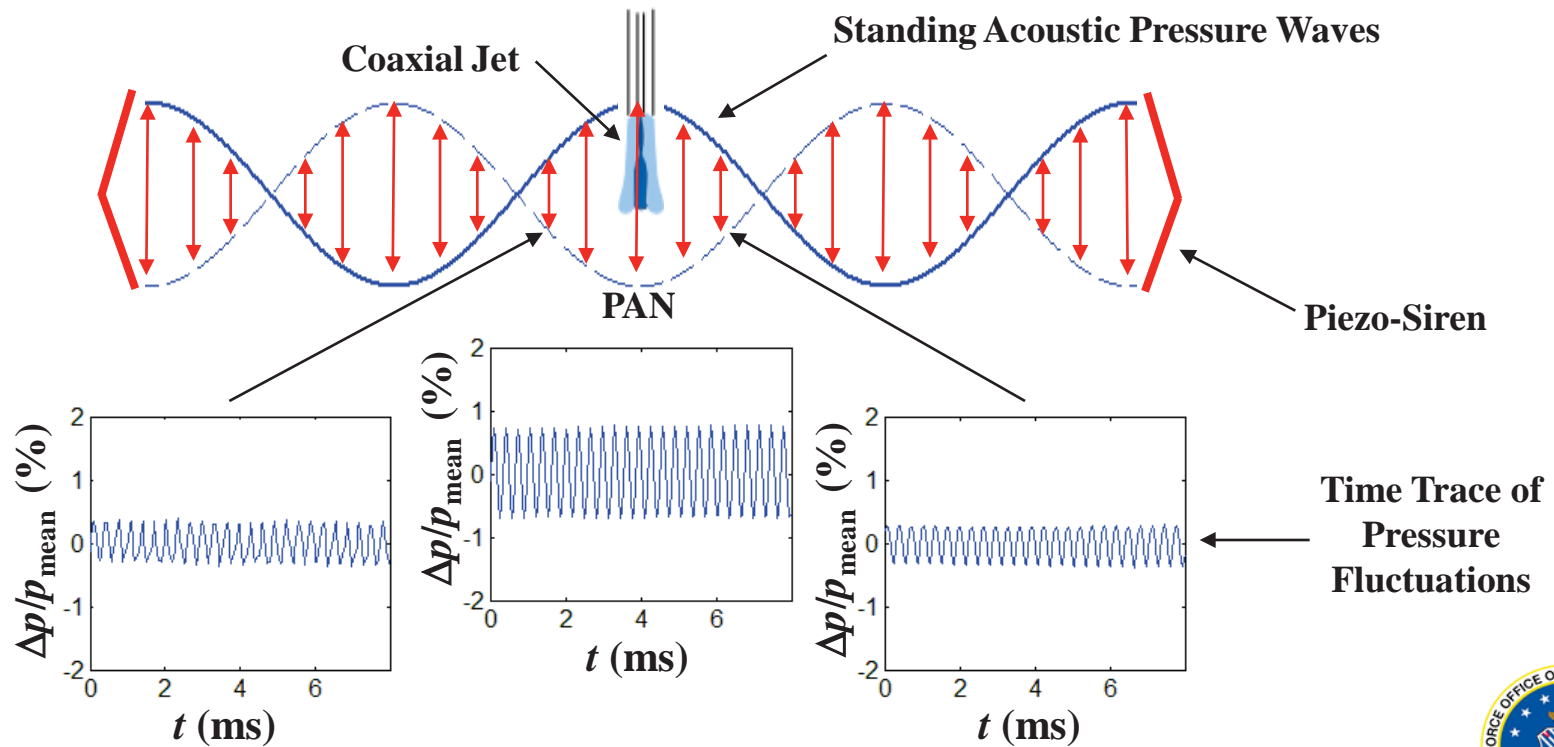

BASELINE FLOW IMAGES AND DARK-CORE LENGTHS



Distribution A: Approved for Public Release; Distribution Unlimited



Baseline Flows: LAR-thin Injector

$P_r = 0.44$

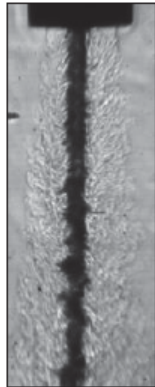

$J = 0.1$

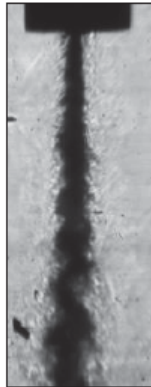

0.5



2.1

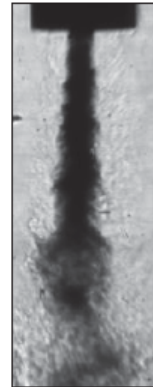

5.2

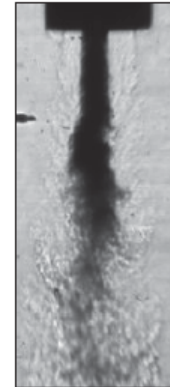

11

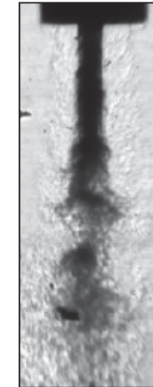

14

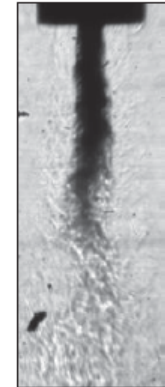

20

$P_r = 1.05$

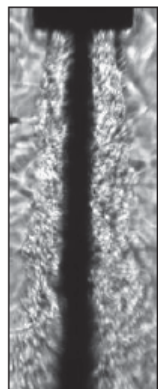

$J = 0.1$

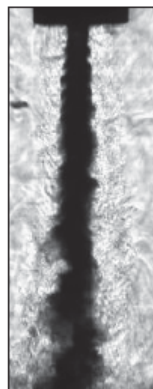

0.5

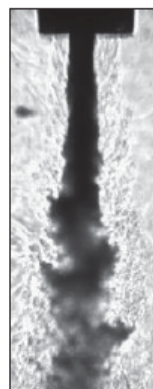

1.9

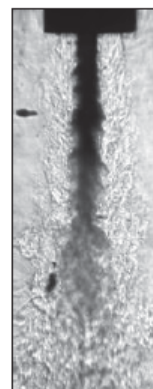

5.0

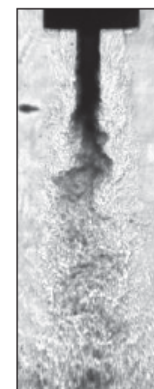

8.5

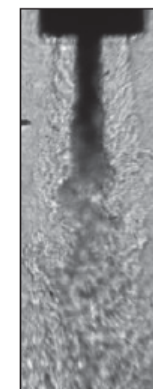

12



Baseline Flows: SAR-thick Injector

$P_r = 0.44$

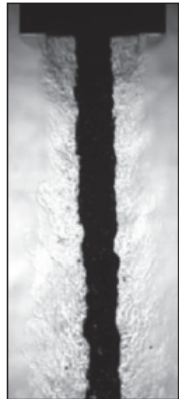

$J = 0.1$

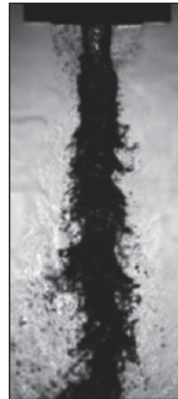

0.5



2.1



5.7

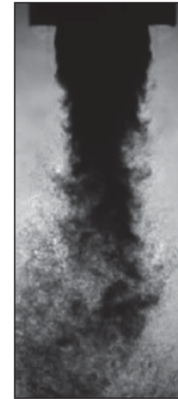

10

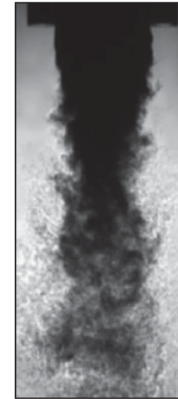

15

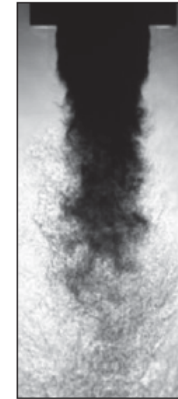

21

$P_r = 1.05$

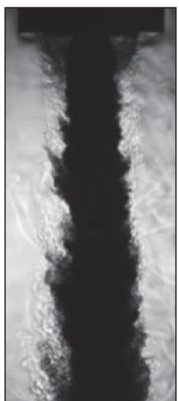

$J = 0.1$

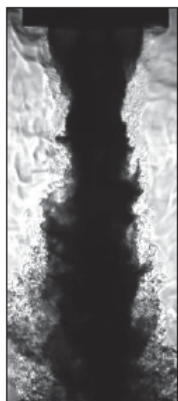

0.5

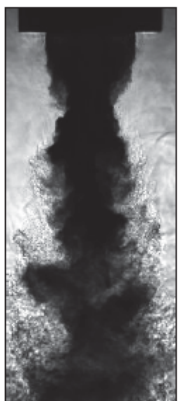

2.1

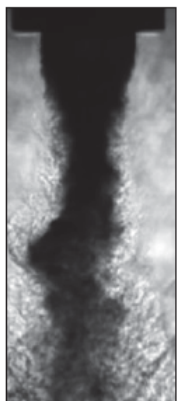

5.2

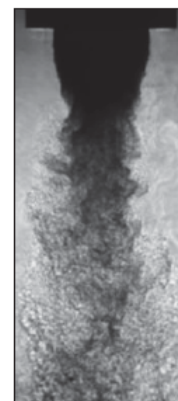

9.2

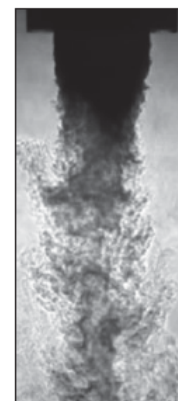

14

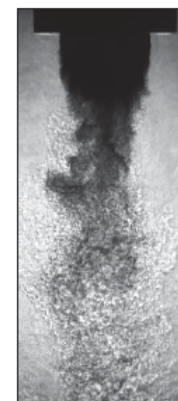

21



Dark-Core Length (DCL) Measurement

- First raw grayscale images were converted to binary images
- A contour was drawn around the “dark-column” in the binary image
- Axial length of the dark-column measured and defined as the Dark-Core Length, L

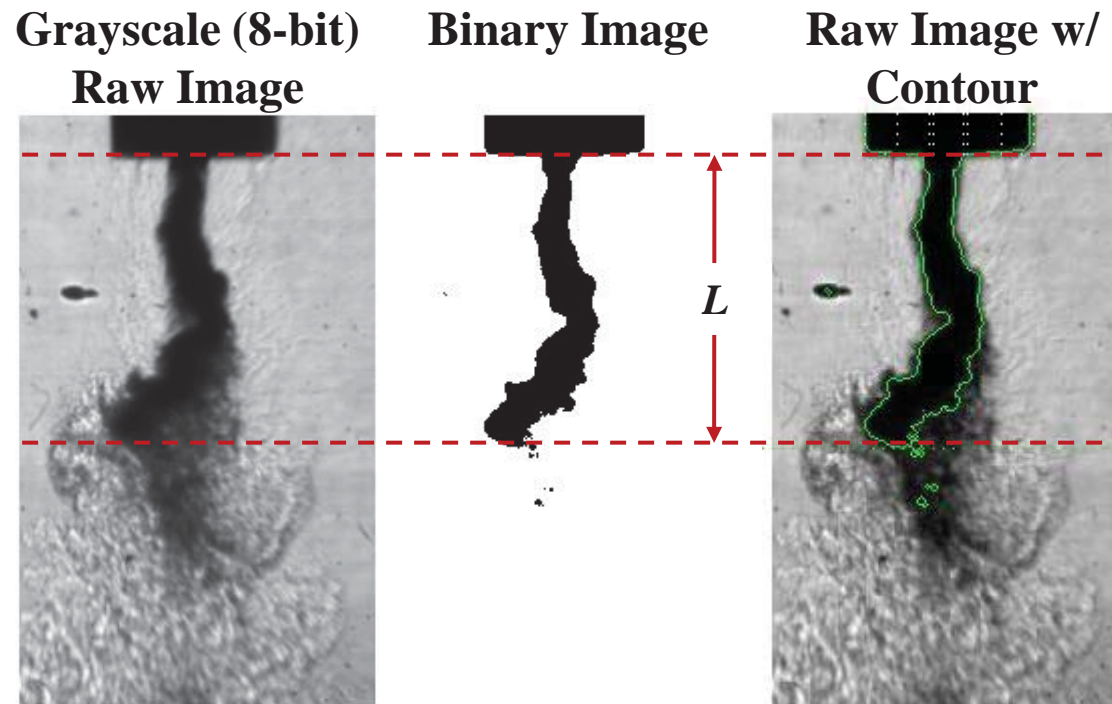

Baseline Normalized DCL, L_B/D_1

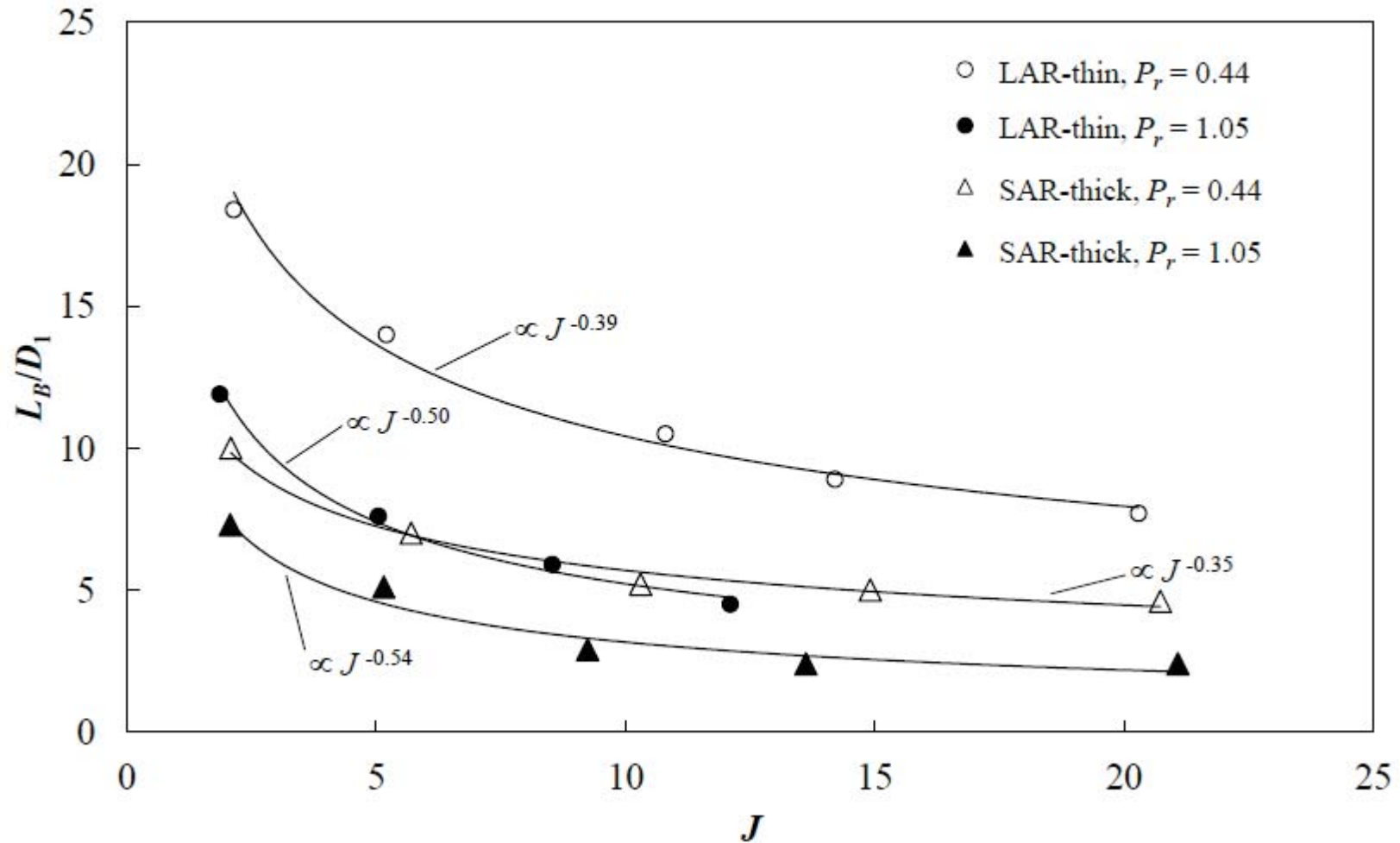

Geometric Configurations

LAR-thin

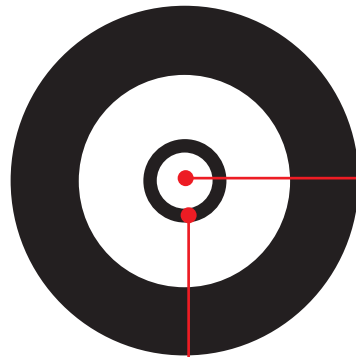

Similar I.D.

LAR-thick

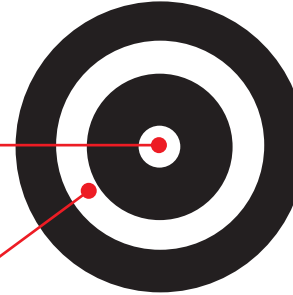
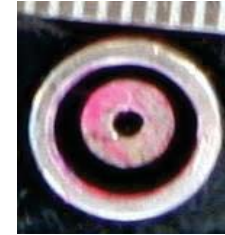

Similar lip thickness/I.D.
Similar Outer Area

SAR-thin

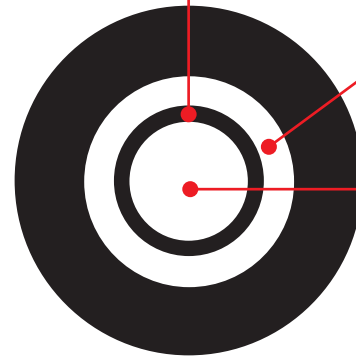
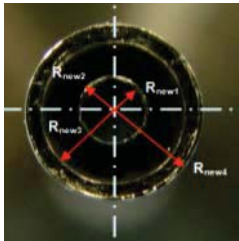

Similar I.D.

SAR-thick

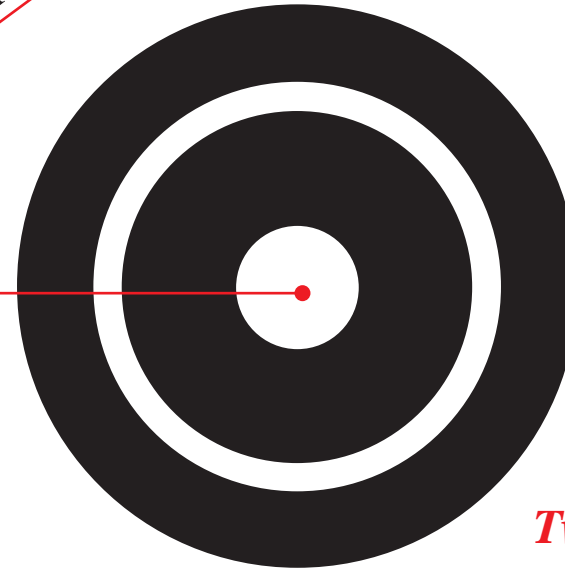

Two recesses

All dimensions in mm

	D_1	D_2	D_3	D_4	t/D_1	A_o/A_i
LAR-thick	0.51	1.59	2.42	3.18	1.05	12.9
SAR-thin	1.40	1.65	2.44	3.94	0.09	1.6
SAR-thick	1.47	3.96	4.70	6.35	0.84	2.9
LAR-thin	0.70	0.89	2.44	3.94	0.13	10.6

SAR, LAR → Small, Large Area Ratio
Thick, Thin → Post lip thickness



Baseline Normalized DCL, L_B/D_1 – $P_r = 0.44$

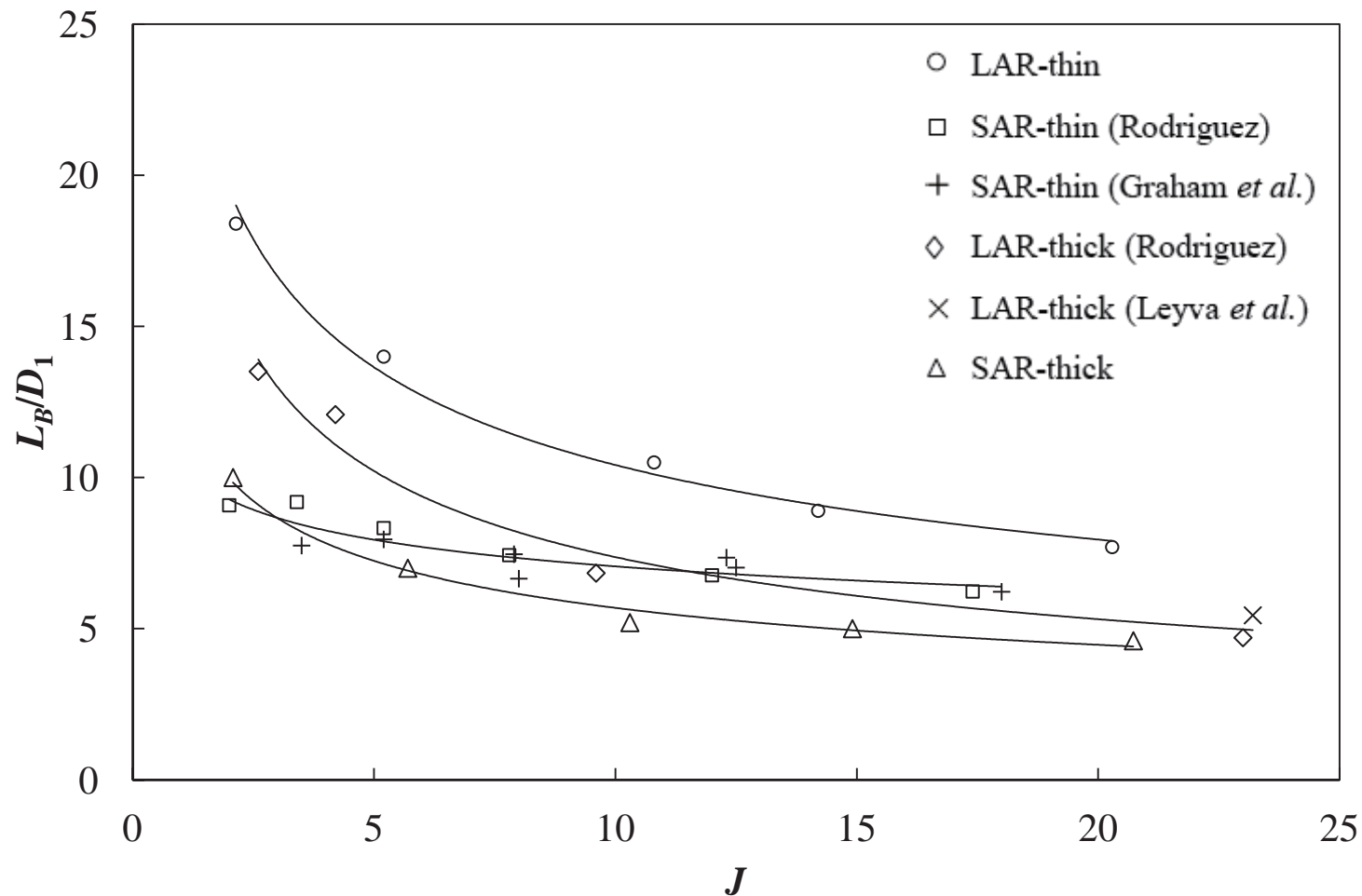

Baseline Normalized DCL, L_B/D_1 – $P_r = 1.05$

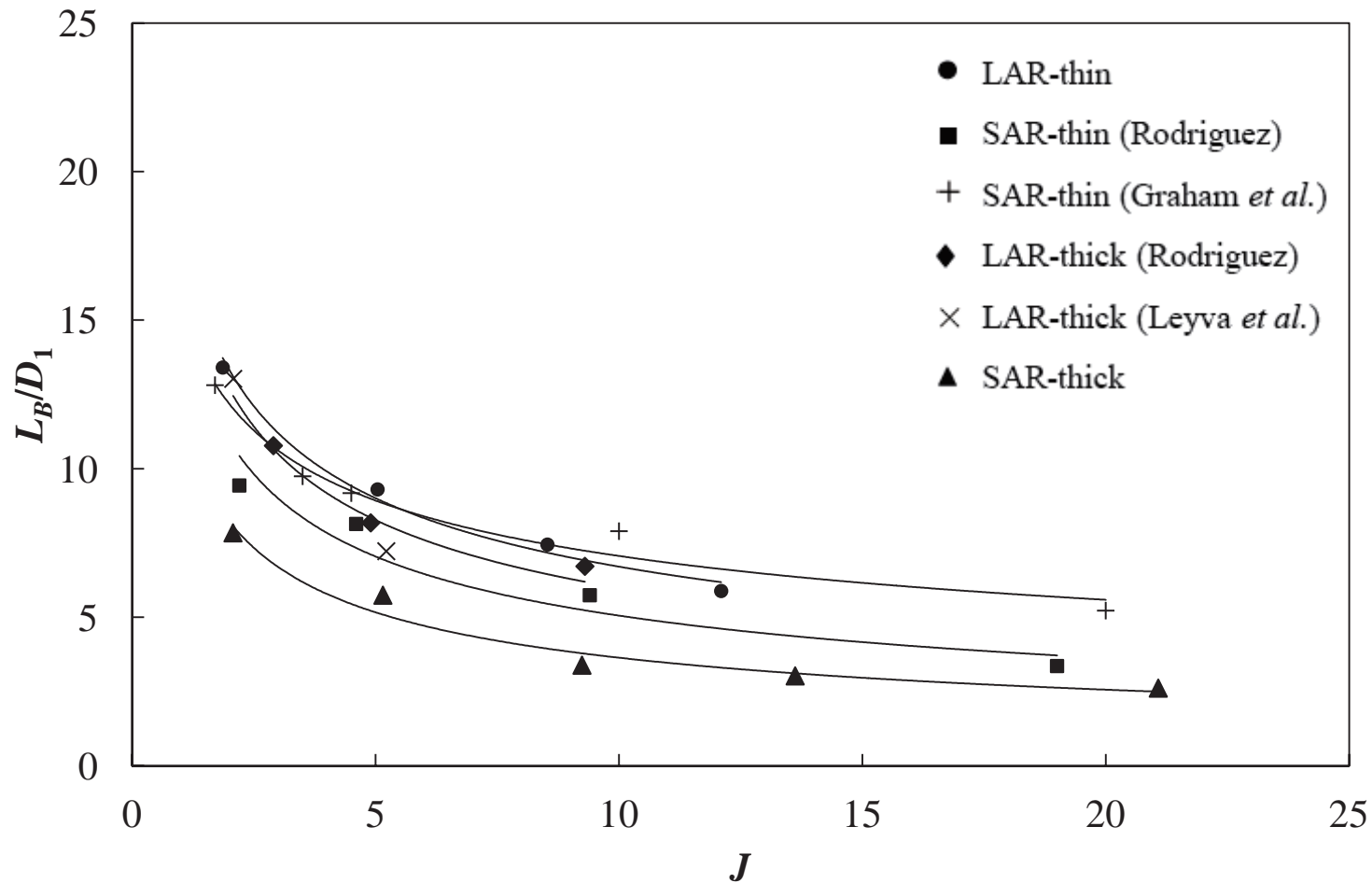

Baseline Normalized DCL, L_B/D_1 Collapse

$$\left(\frac{L_B}{D_1}\right) = c_1 J^{c_2} \left(\frac{t}{D_1}\right)^{c_3} \left(\frac{A_o}{A_i}\right)^{c_4}$$

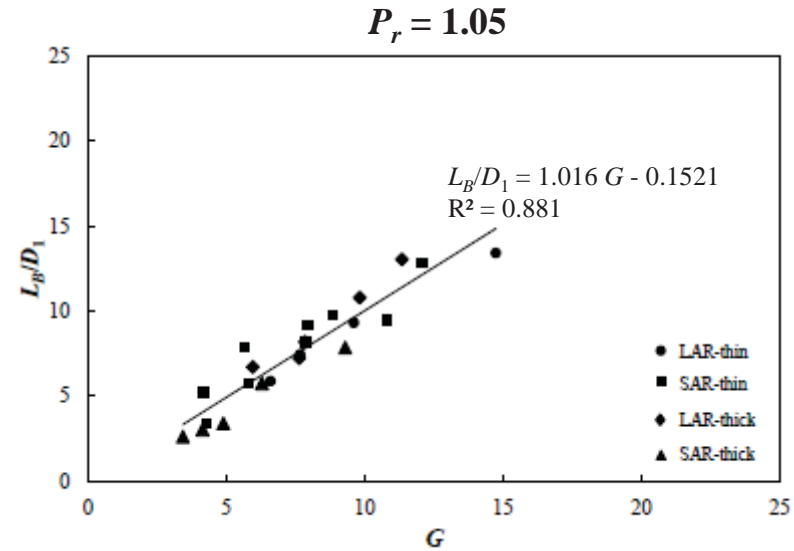
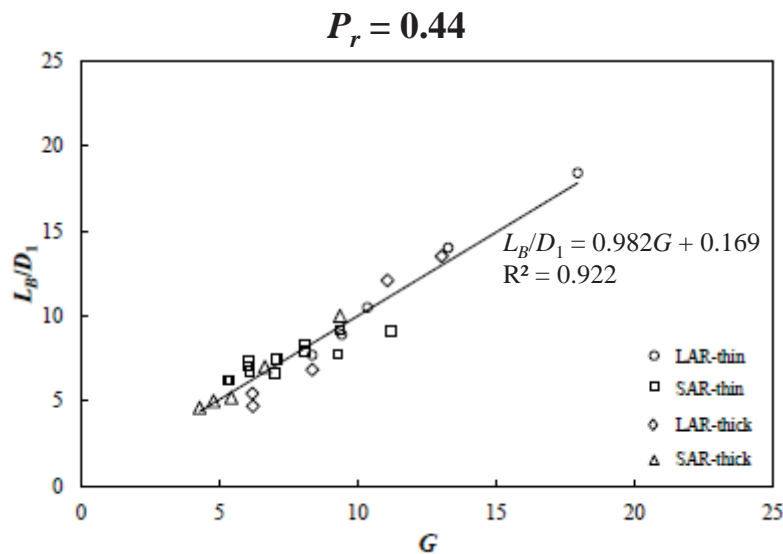

P_r	c_1	c_2	c_3	c_4
0.44	9	-0.34	-0.15	0.30
1.05	11	-0.43	-0.12	0.15



ACOUSTICALLY FORCED FLOW IMAGES AND DARK-CORE LENGTHS



Distribution A: Approved for Public Release; Distribution Unlimited



Acoustically Forced Flows: LAR-thin – $P_r = 0.44$

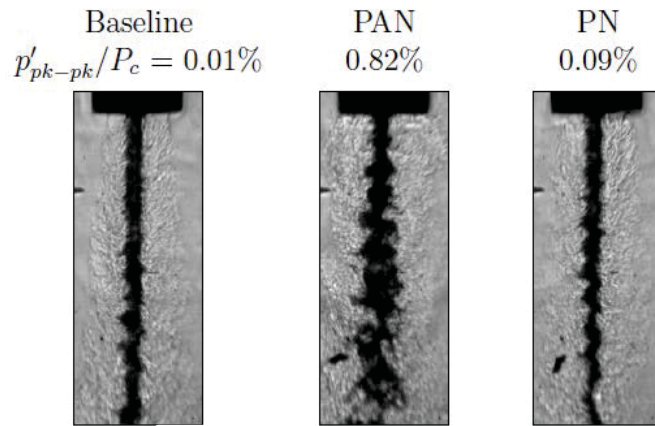

$J = 0.1, f_F = 3.13$ kHz

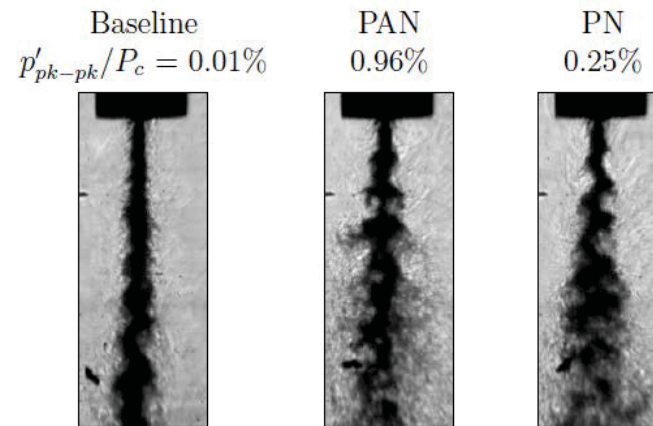

$J = 0.5, f_F = 3.14$ kHz

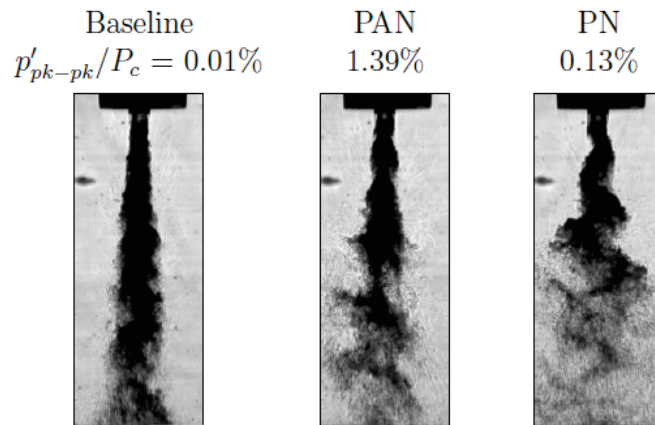

$J = 2.1, f_F = 3.12$ kHz

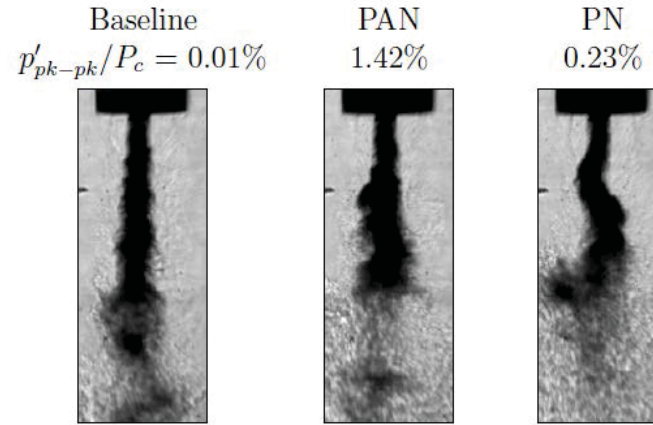

$J = 5.2, f_F = 3.12$ kHz

Acoustically Forced Flows: LAR-thin – $P_r = 0.44$

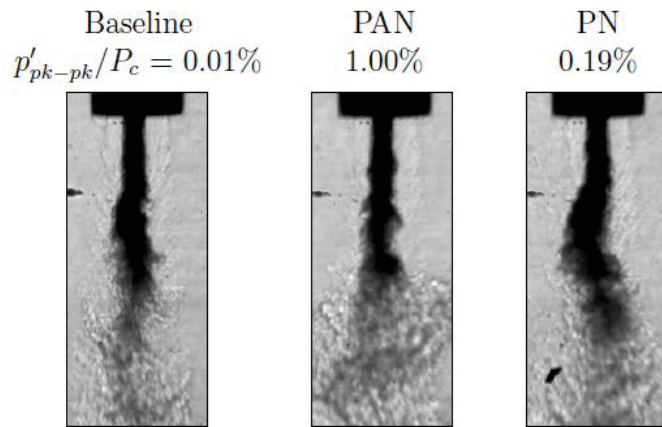

$J = 11, f_F = 3.10$ kHz

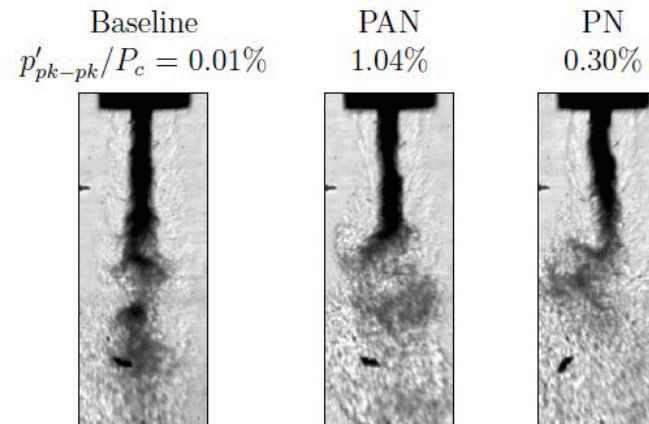

$J = 14, f_F = 3.11$ kHz

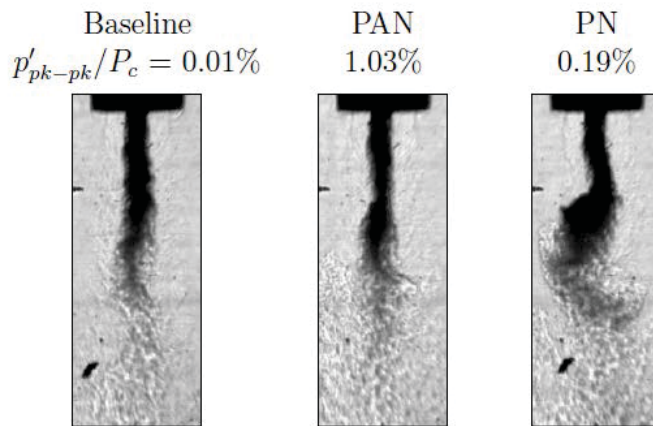

$J = 20, f_F = 3.11$ kHz



Acoustically Forced Flows: LAR-thin – $P_r = 1.05$

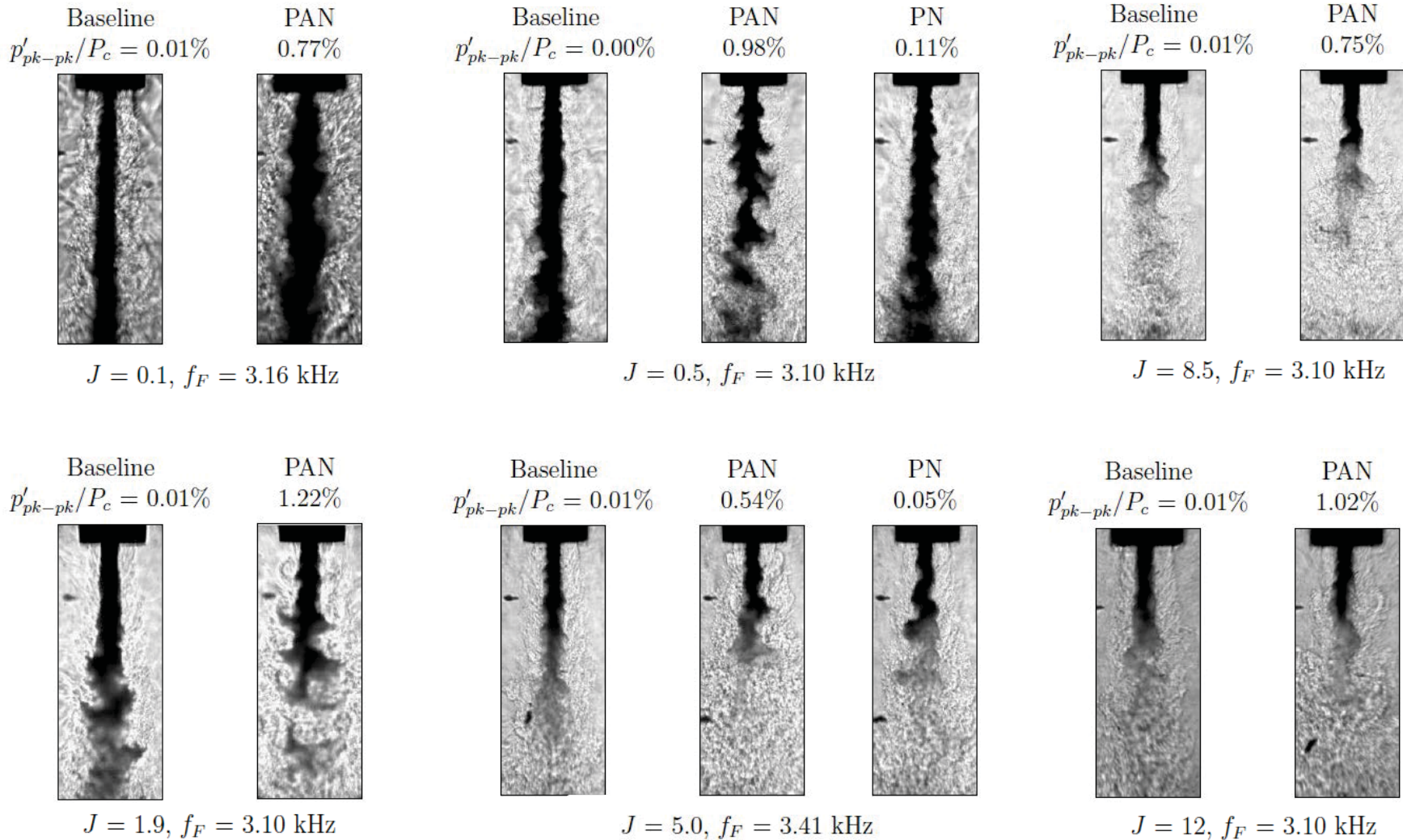

PAN Forcing: 40 μ s Interval Image Sequence

LAR-thin, $P_r = 0.44$, $J = 0.5$

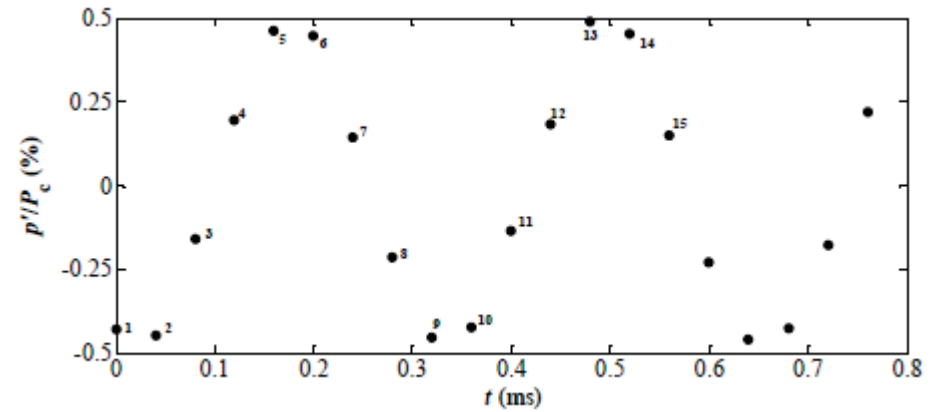
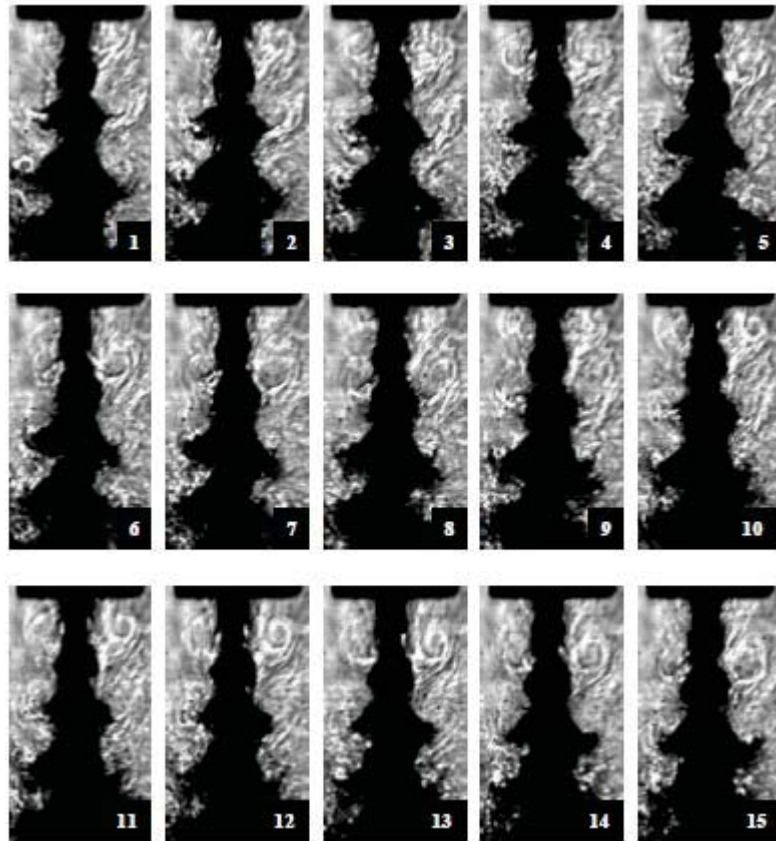

PAN Forcing: 40 μ s Interval Image Sequence

LAR-thin, $P_r = 0.44$, $J = 11$

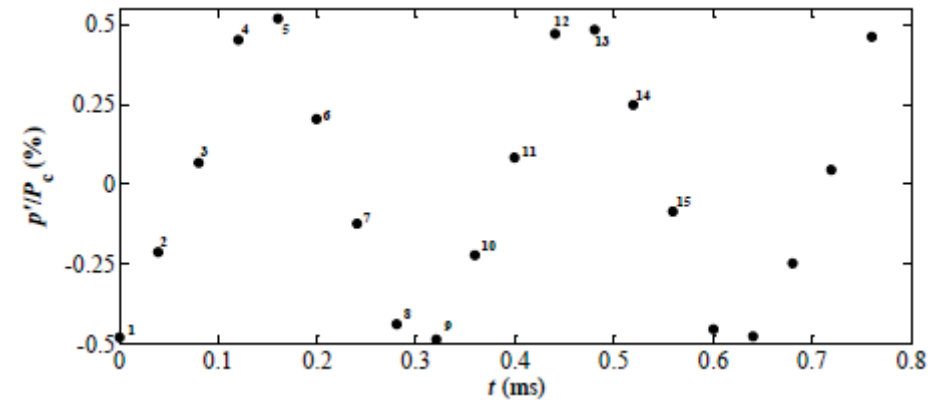
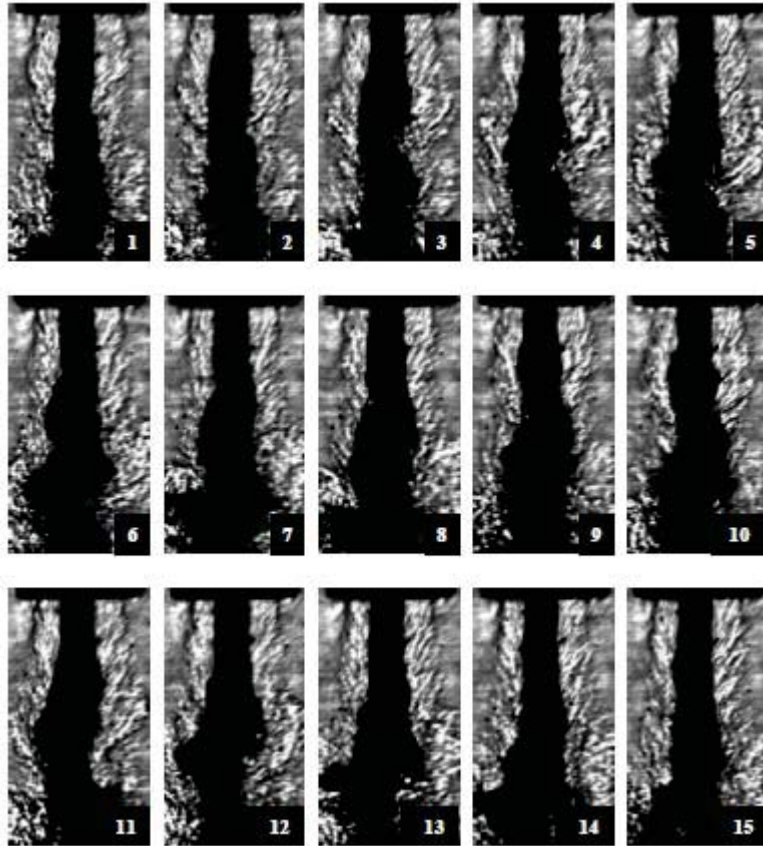

Acoustically Forced Flows: SAR-thick – $P_r = 0.44$

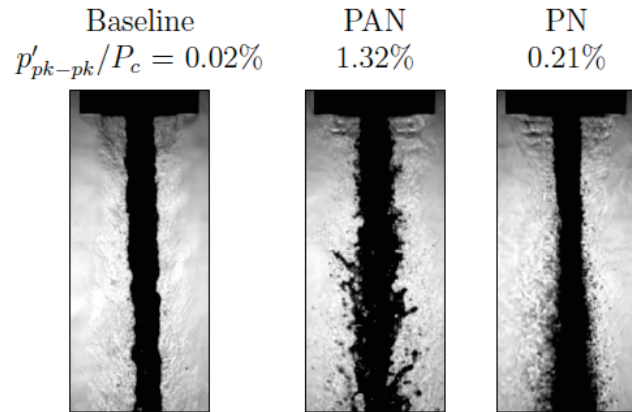

$J = 0.1, f_F = 3.10$ kHz

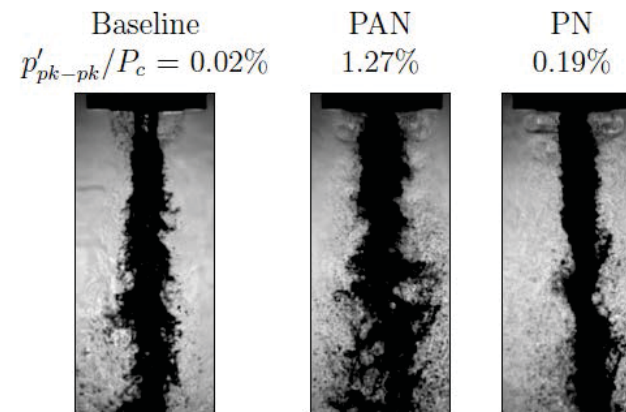

$J = 0.5, f_F = 3.04$ kHz

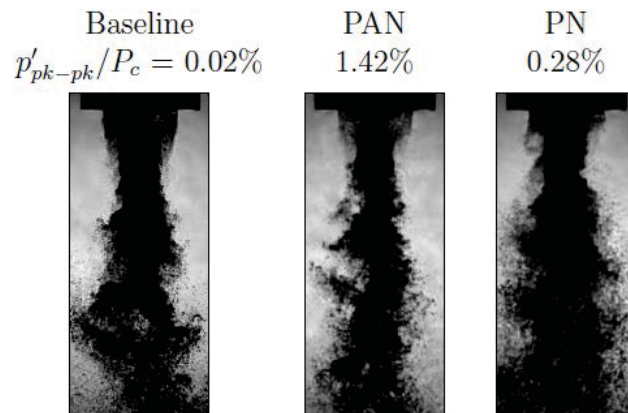

$J = 2.1, f_F = 3.07$ kHz

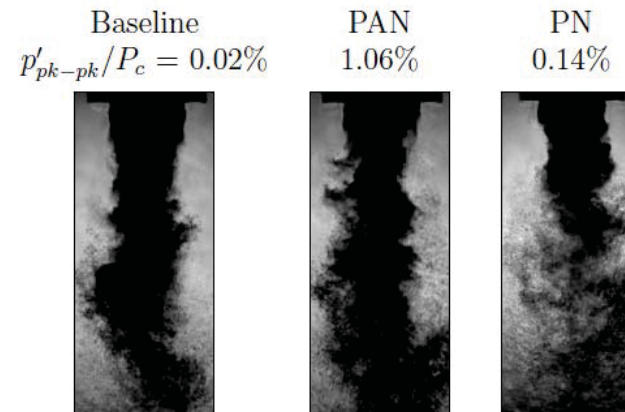

$J = 5.7, f_F = 3.11$ kHz



Acoustically Forced Flows: SAR-thick – $P_r = 0.44$

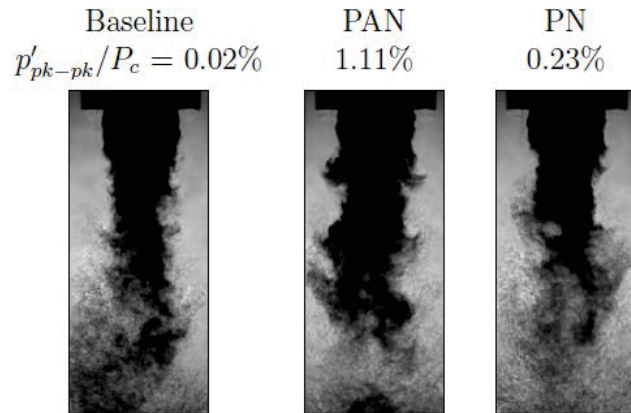

$J = 10, f_F = 3.11$ kHz

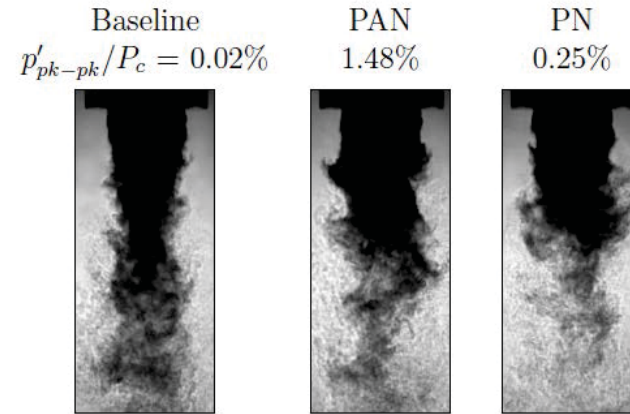

$J = 15, f_F = 3.04$ kHz

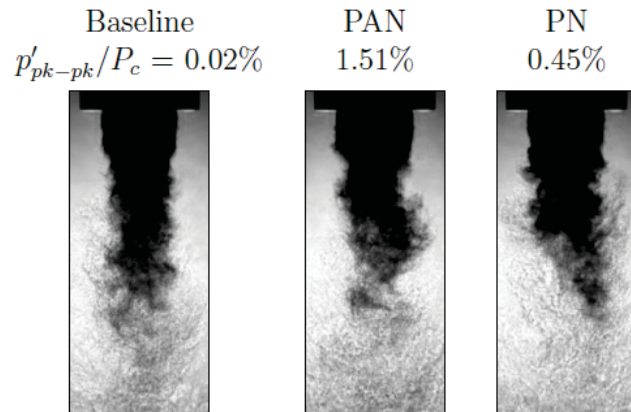

$J = 21, f_F = 3.11$ kHz



Acoustically Forced Flows: SAR-thick – $P_r = 1.05$

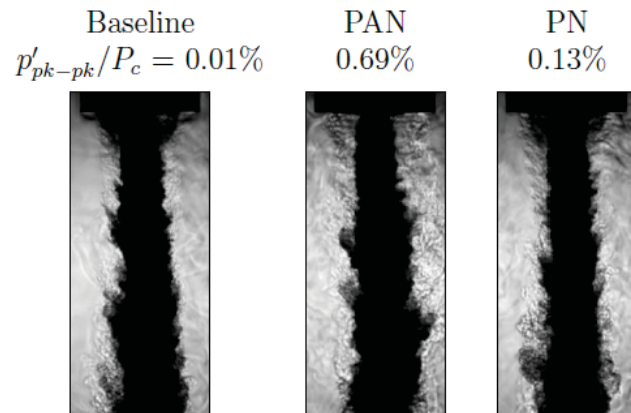

$J = 0.1, f_F = 3.12$ kHz

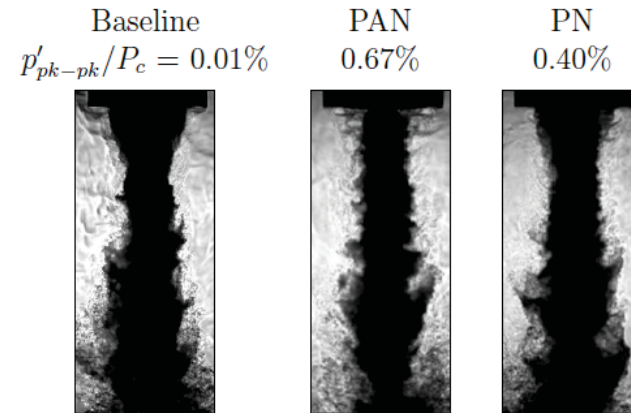

$J = 0.5, f_F = 3.00$ kHz

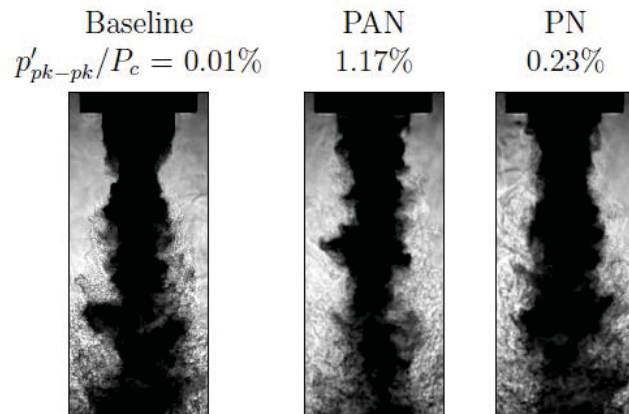

$J = 2.1, f_F = 3.04$ kHz

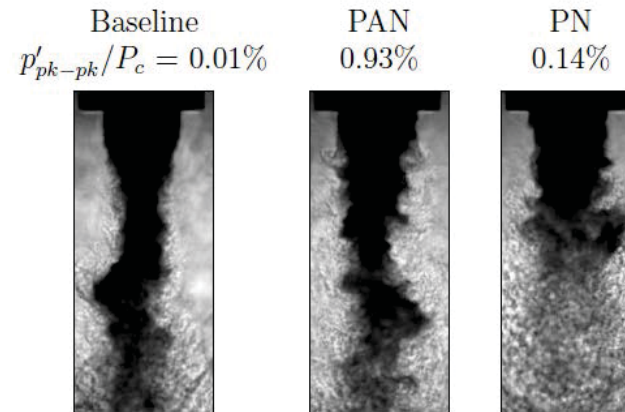

$J = 5.2, f_F = 3.08$ kHz



Acoustically Forced Flows: SAR-thick – $P_r = 1.05$

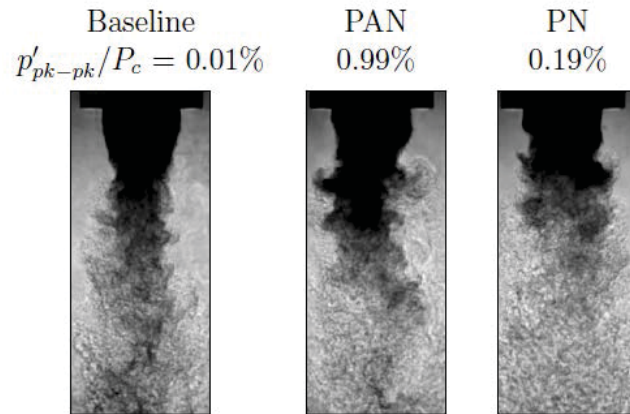

$J = 9.2, f_F = 3.11$ kHz

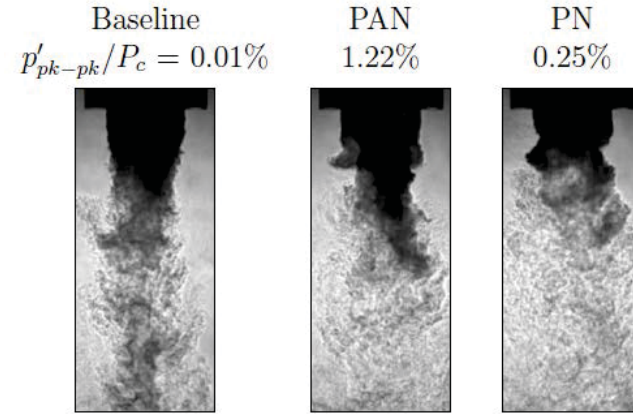

$J = 14, f_F = 3.04$ kHz

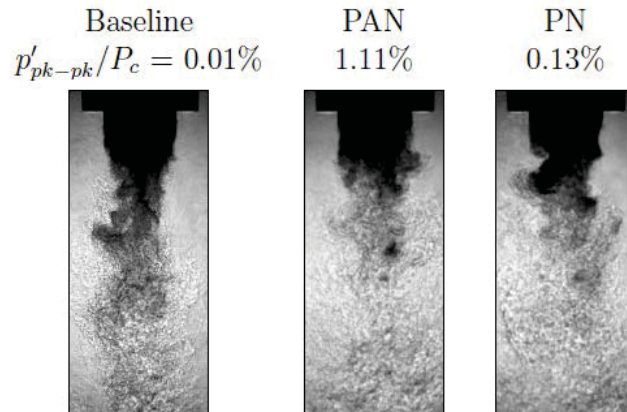

$J = 21, f_F = 3.12$ kHz



PAN Forcing: Normalized DCL, L_{PAN}/L_B

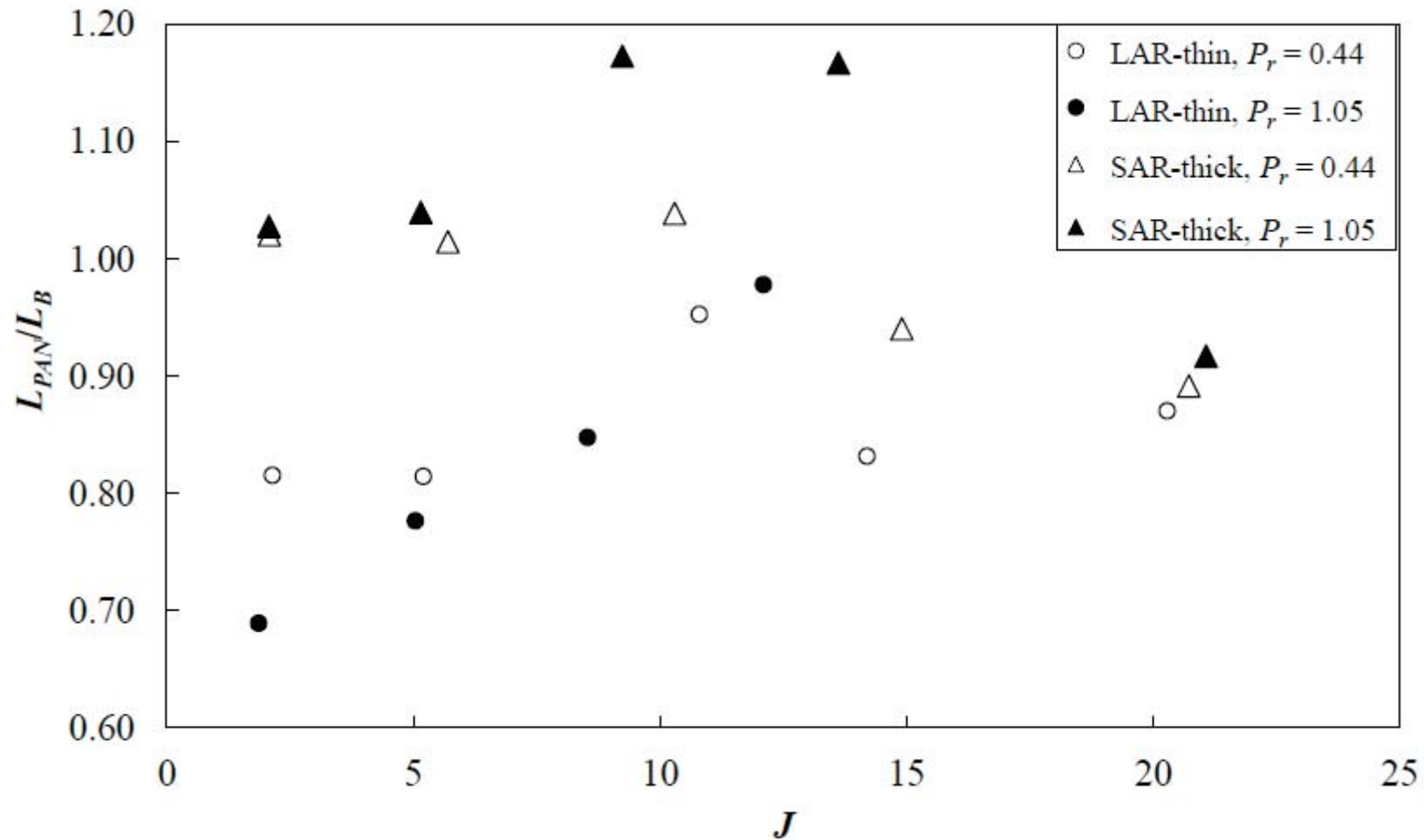

PN Forcing: Normalized DCL, L_{PN}/L_B

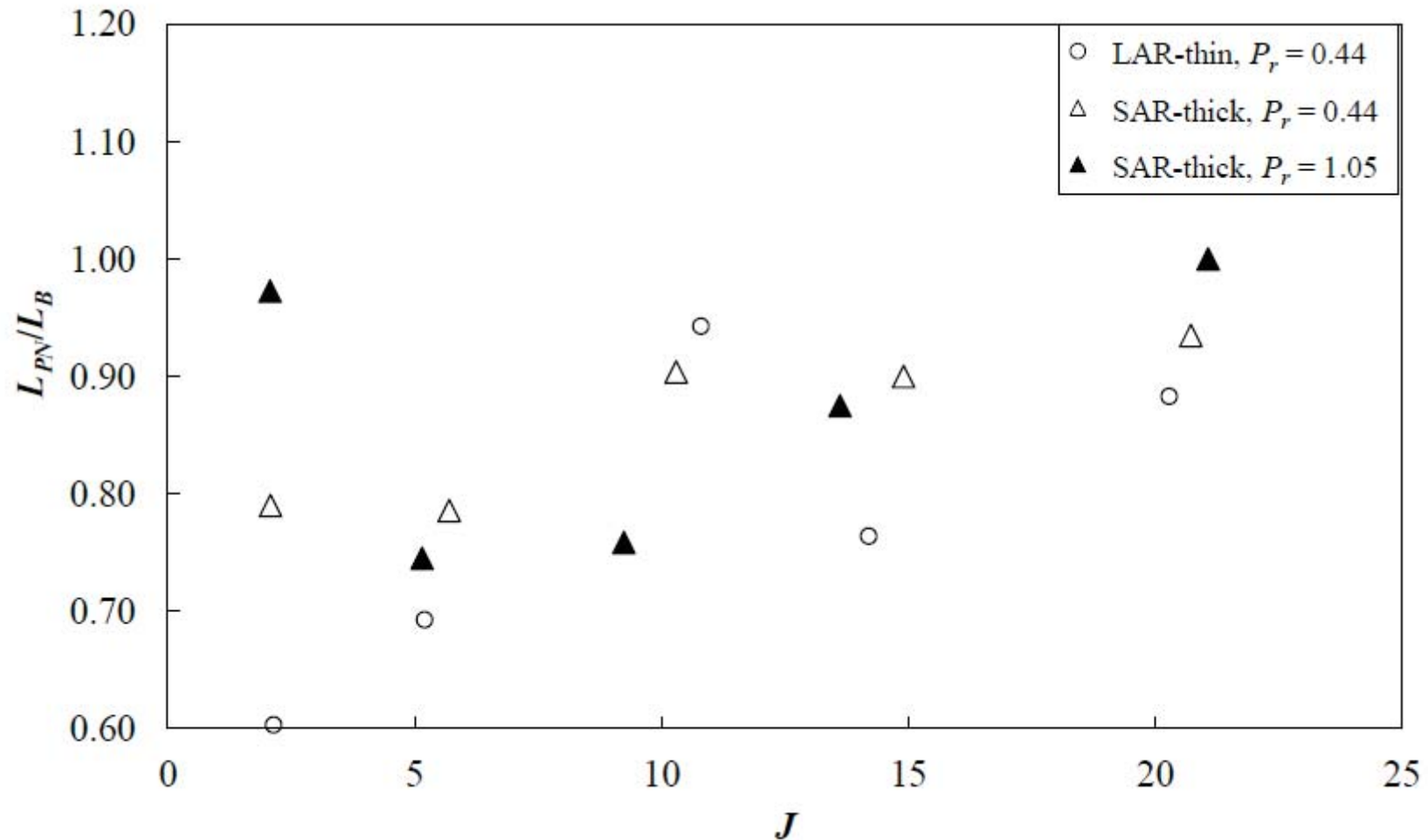

APPLICATION OF POD ON IMAGE PIXEL INTENSITIES



Distribution A: Approved for Public Release; Distribution Unlimited



Proper Orthogonal Decomposition

- Proper Orthogonal Decomposition (POD) or Principal Component Analysis (PCA) was used for extracting dominant dynamical processes embedded in high-speed images.
- A time-resolved set of images $A(x,t)$ can be represented as a linear combination of orthonormal basis functions ϕ_k (aka proper orthogonal modes)^{1,2} :

$$A(x,t) = \sum_{k=1}^M a_k(t)\phi_k(x)$$

where $a_k(t)$ are time dependent orthonormal amplitude coefficients and M is the number of modes

- Main idea: POD modal amplitudes capture the maximum possible “energy” in an average sense³, i.e.,

$$\sum_k \langle a_k(t)a_k(t) \rangle \geq \sum_k \langle b_k(t)b_k(t) \rangle$$

where $b_k(t)$ are the temporal coefficients of a decomposition with respect to an arbitrary orthonormal basis ψ_k .

¹ Chatterjee, A. *Current Science*, Vol. 78, No. 7 (2000)

² Arienti, M, and Soteriou, M.C.. *Phys. Fluids* 21, 112104 (2009)

³ Berkooz, G., Holmes, P., and Lumley, J.L.. *Annu. Rev. Fluid Mech.* 25. 539 (1993)



Construction of Data Set

- First, form a row vector consisting of all pixel intensity values of each snapshot image (with resolution of n rows by m columns) in order of increasing columns, then increasing rows

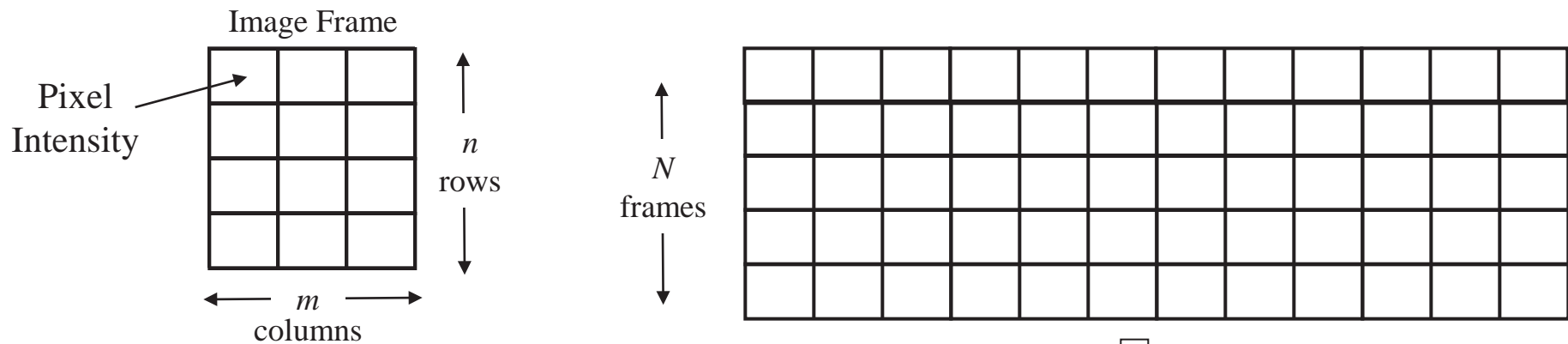

- Then, combine all such row vectors for N sequences of image frames resulting in a matrix \mathbf{A} consisting of N rows by $P = n \times m$ columns of intensity values.

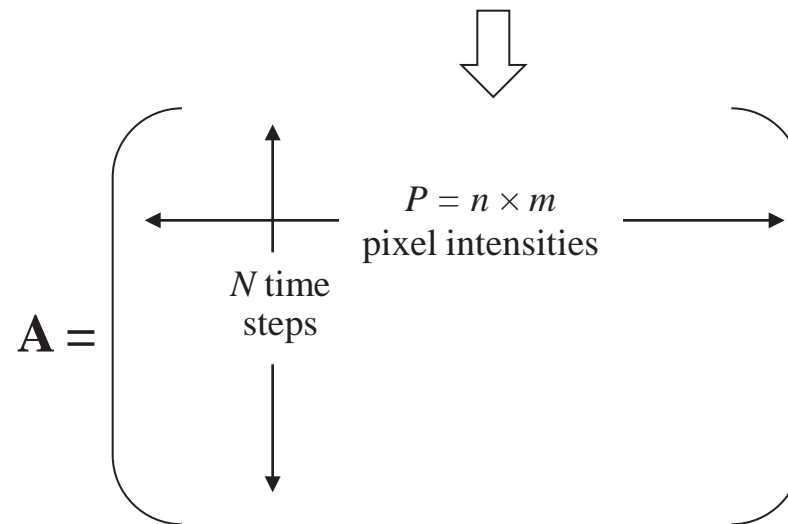

Orthogonal Decomposition Technique

- Eigenvalue decomposition or singular value decomposition (SVD) can be used
- SVD preferred since
 1. Applicable to non-square matrices (most likely the case)
 2. Decomposition matrices are orthogonal
 3. Subroutine readily available in MATLAB[®]
- Subtracted temporal mean of $\mathbf{A} \Rightarrow$ matrix of intensity fluctuations $\tilde{\mathbf{A}}$
- Applied SVD

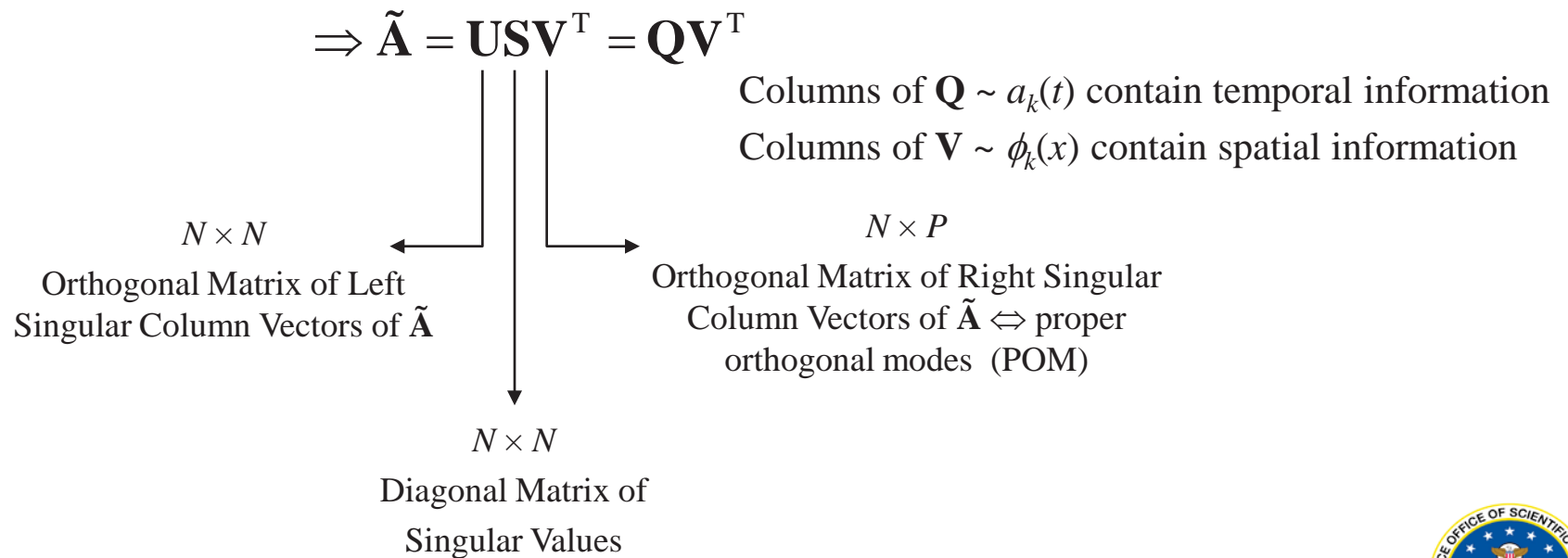

Results – Baseline Low J Flow at $Pr = 0.44$

- LAR-thin, $Pr = 0.44$, $J = 0.5$

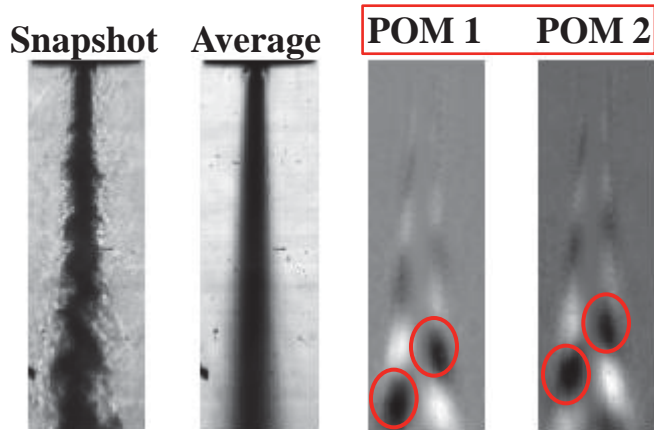

Amplitude information contained in singular values

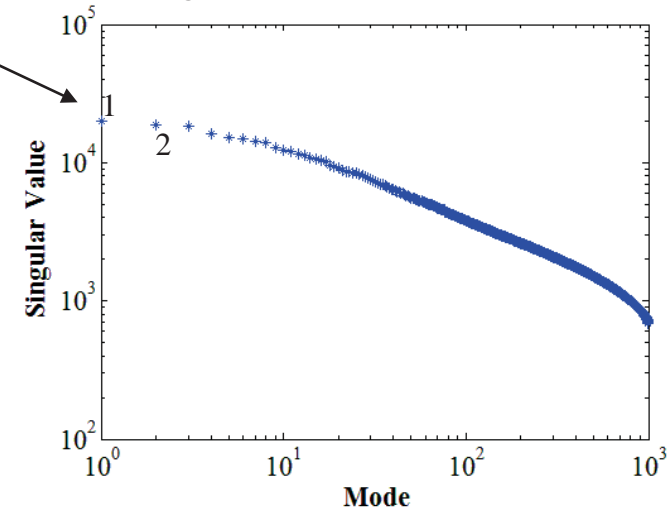

Antisymmetric Structures
Identified with Characteristic Frequencies

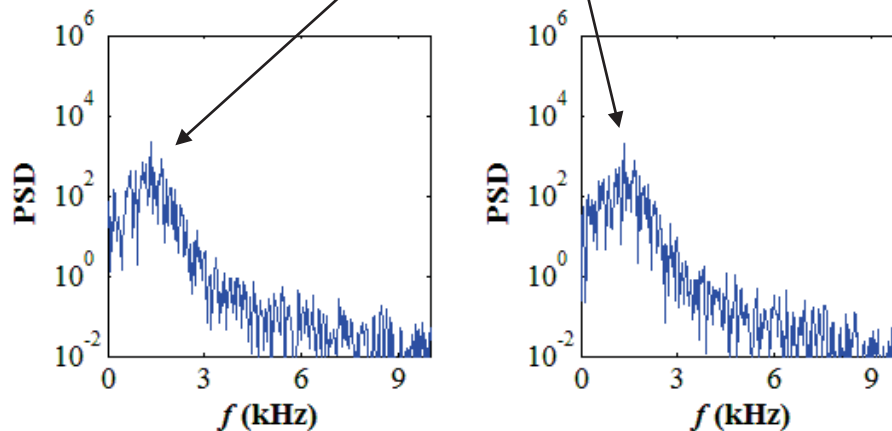

Power Spectral Densities (PSD) of Temporal Coefficients of POMs 1 and 2



Results – PAN Low J Flow at $P_r = 0.44$

- LAR-thin, $Pr = 0.44$, $J = 0.5$, forcing Frequency, $f_F = 3.14$ kHz

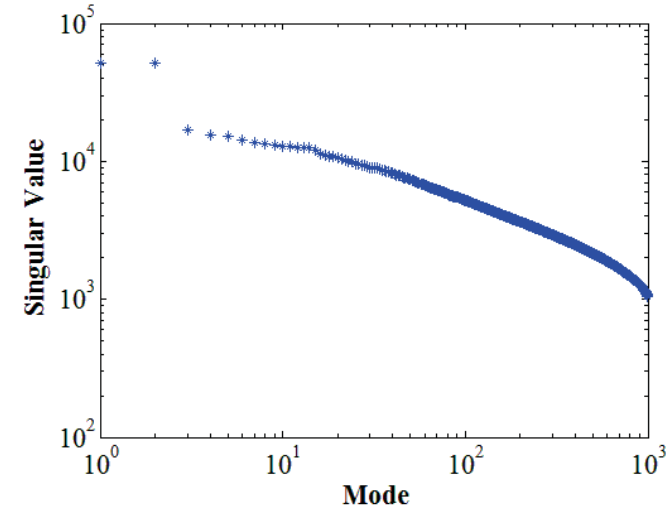
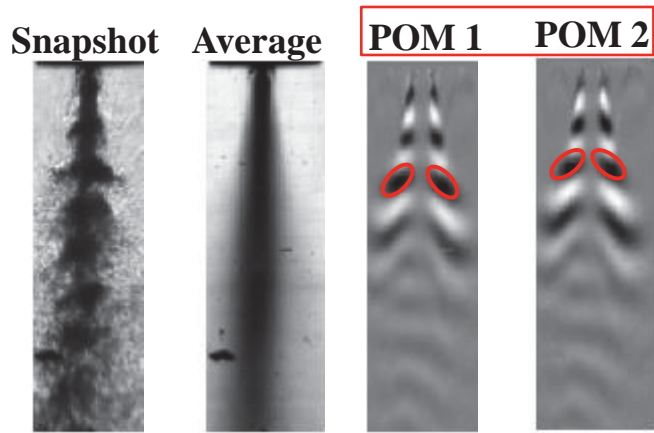

Symmetric Structures
Identified with Characteristic
Frequency at f_F

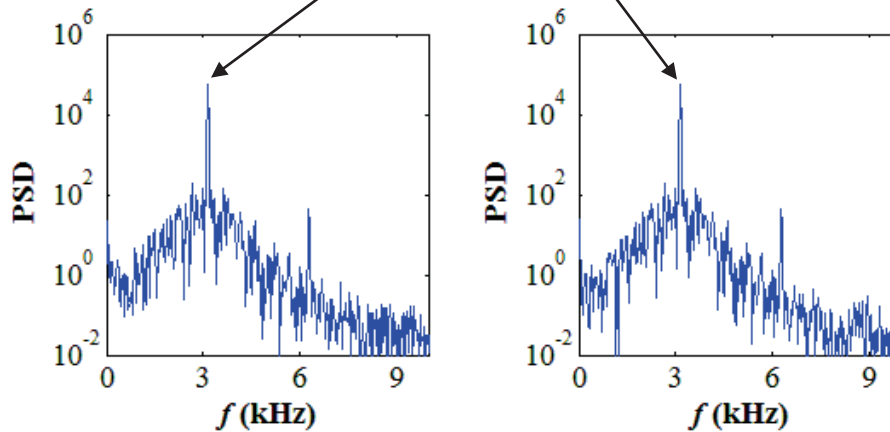

Distribution A: Approved for Public Release; Distribution Unlimited



Results – PN Low J Flow at $Pr = 0.44$

- LAR-thin, $Pr = 0.44$, $J = 0.5$, forcing Frequency, $f_F = 3.14$ kHz

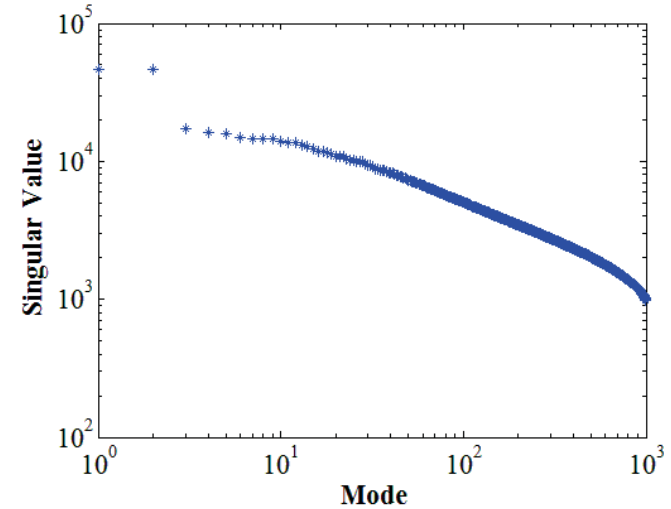
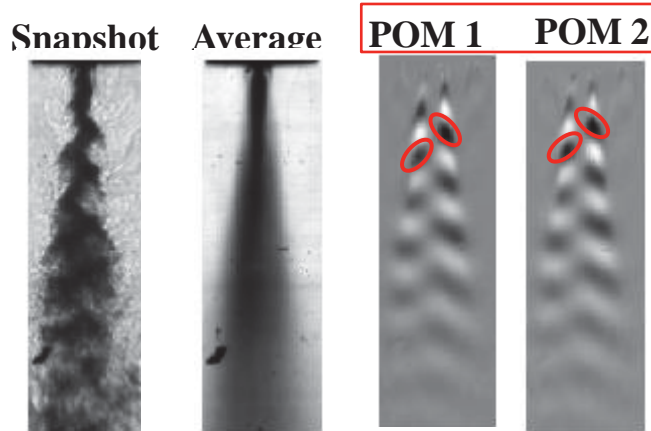

Antisymmetric Structures
Identified with Characteristic Frequency at f_F

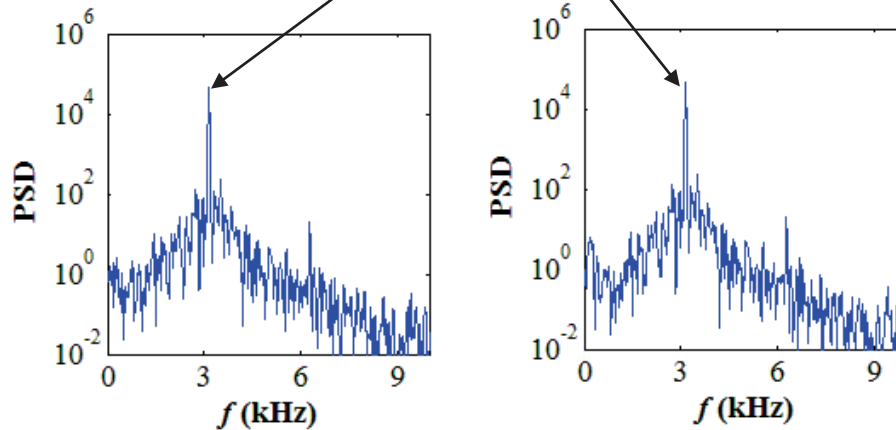

Cross-Power Spectral Density (CPSD)

- CPSD yields the FFT of the cross-correlation of the temporal coefficients

$$\text{CPSD} = \sum_{k=0}^{N-1} \frac{\text{cov}(a_x, a_y)}{\sigma_{a_x} \sigma_{a_y}} e^{-i\omega k}$$

- Magnitude and phase plots used to determine existence of propagating structures

LAR, $Pr = 0.44$, $J = 0.5$

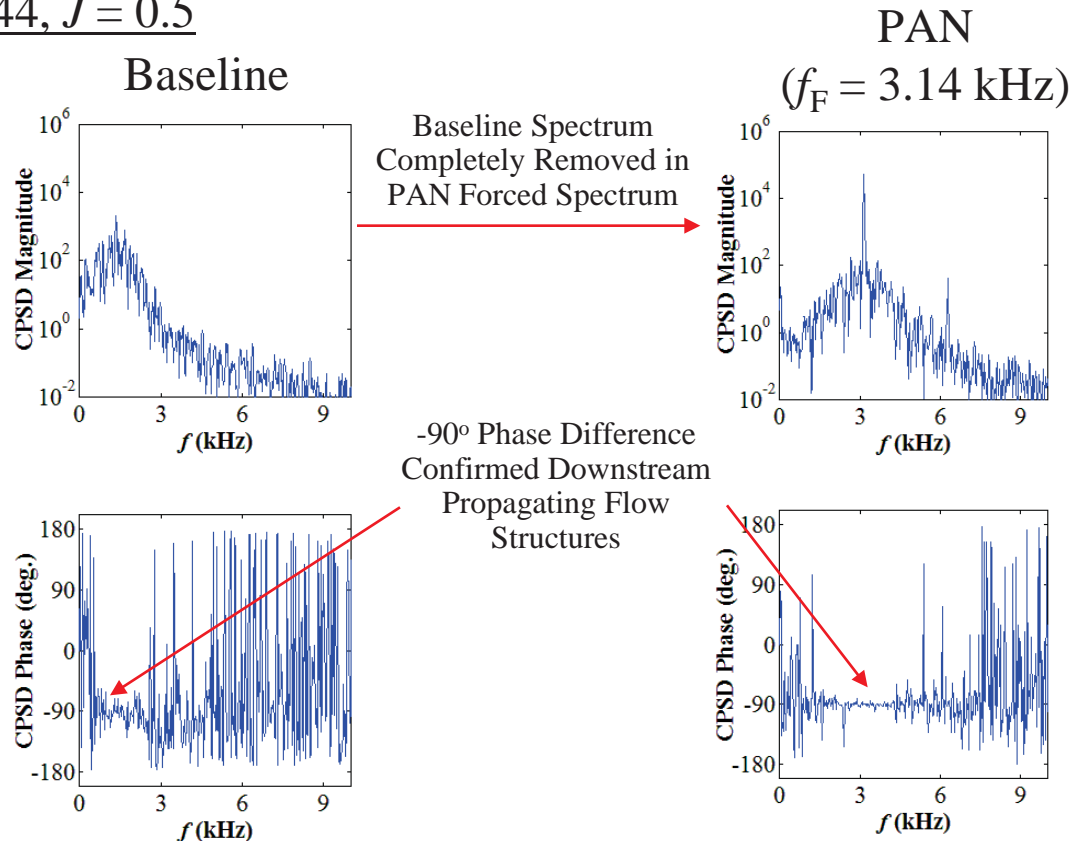

Sample Animation – PAN ($f_F = 3.14$ kHz)

- LAR $Pr = 0.44$, $J = 0.5$

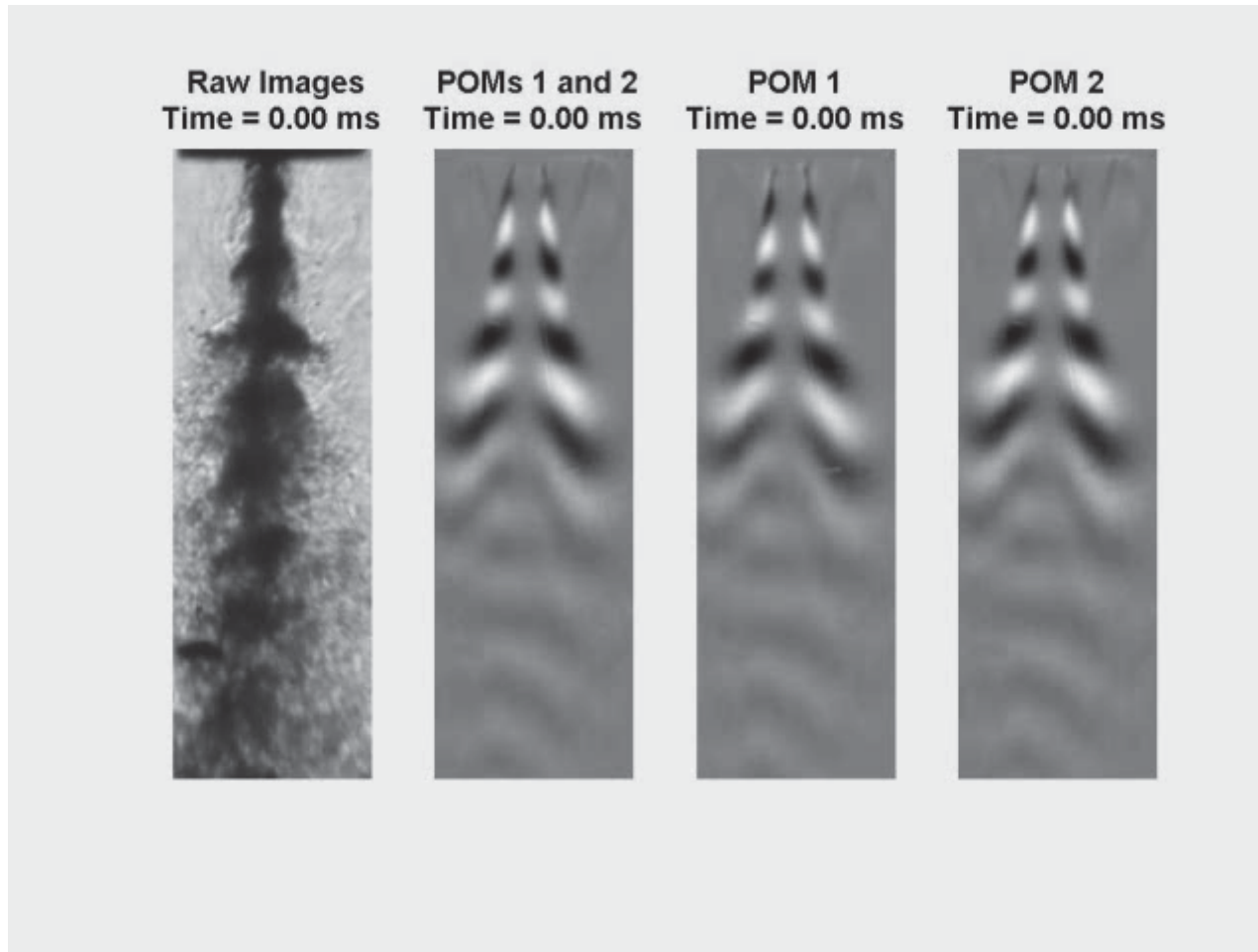

Superposition of POMs 1 and 2 Resulted in Downstream Propagating Structures

Distribution A: Approved for Public Release; Distribution Unlimited



Baseline POM & CPSD: LAR-thin – $P_r = 0.44$

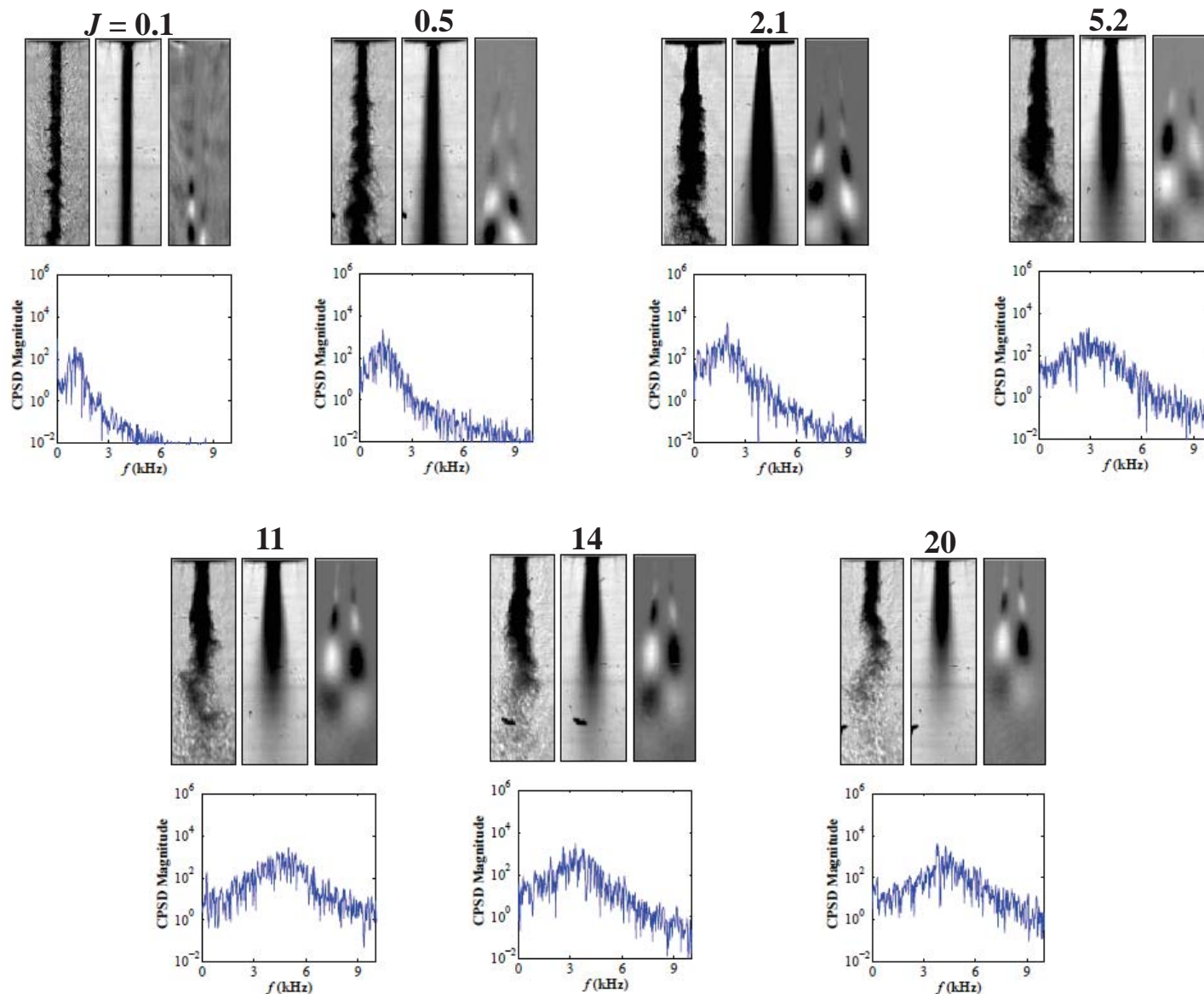

Baseline POM & CPSD: LAR-thin – $P_r = 1.05$

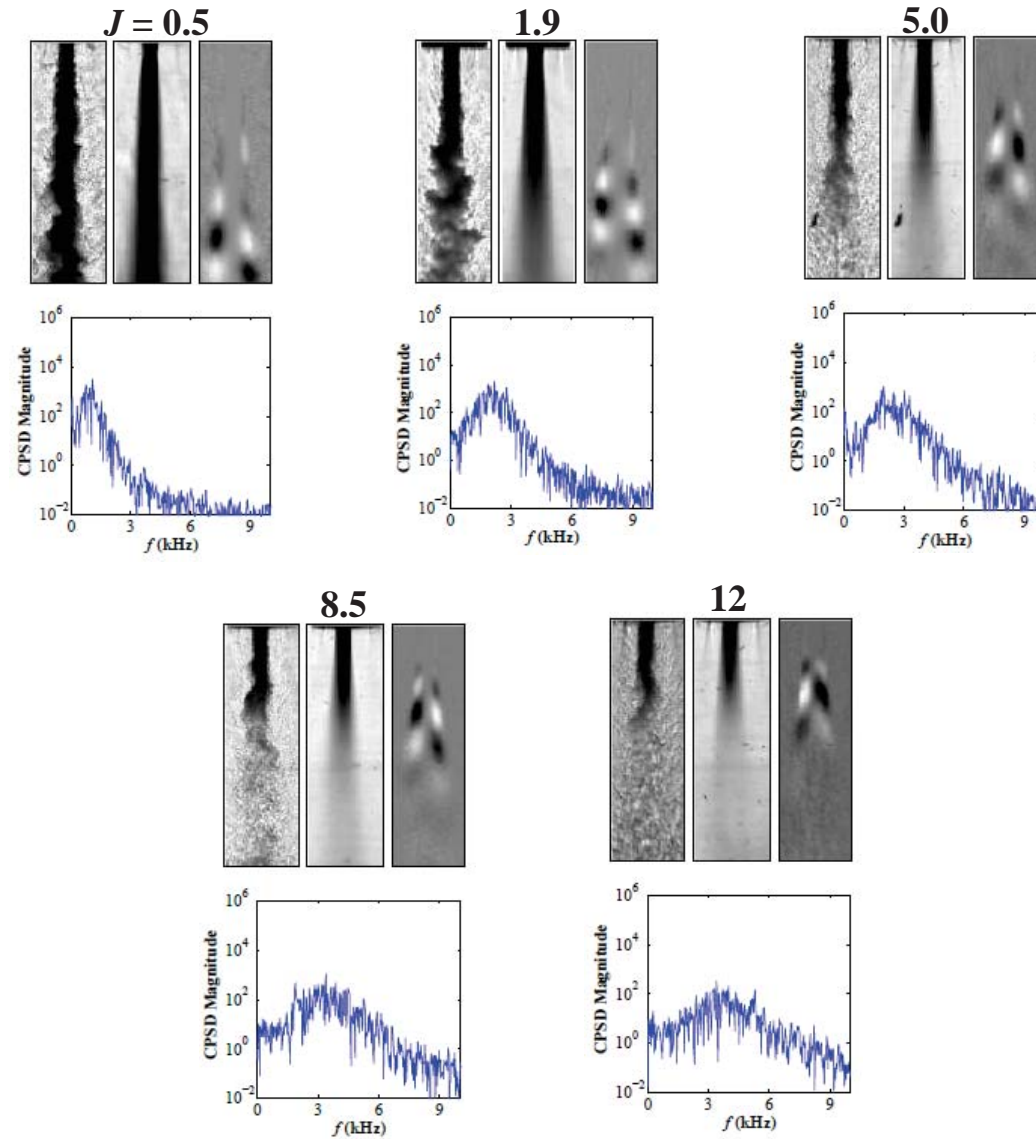

Previous Works on Jet Instability

- Michalke and Hermann (1982) did linear, inviscid instability analysis of a circular jet with coflow
- Showed that with increasing coflow velocity, U_∞
 - Helical disturbances more unstable than axisymmetric ones farther downstream of exit
 - Jet flow becomes less unstable, but spectrum of spatial growth rate becomes broader and the peak shifts to higher frequencies

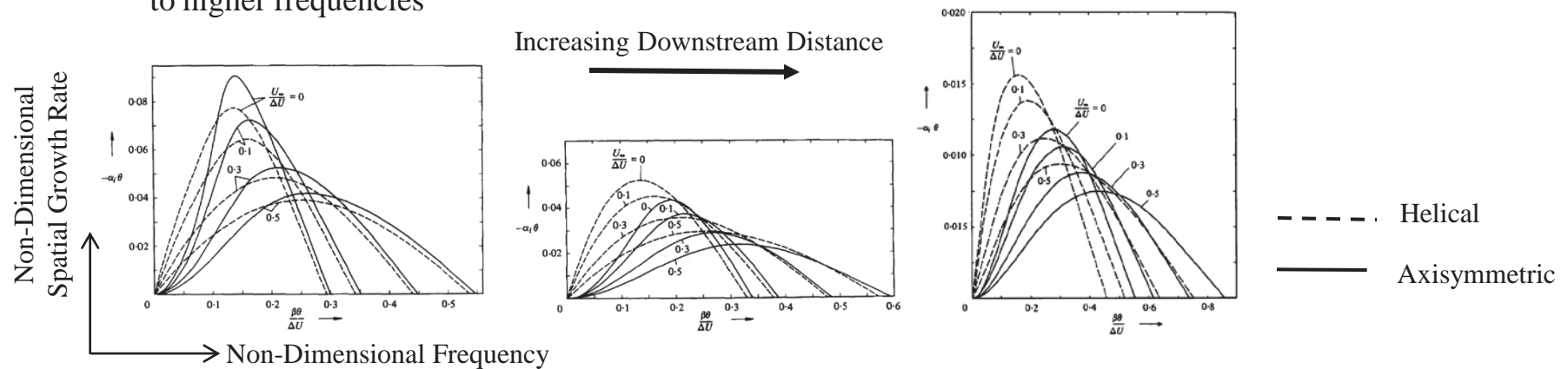

- Dahm *et al.* (1992), Wicker and Eaton (1994) conducted experimental investigation of large-scale vortex structures in the near field of coaxial jets
 - For outer-to-inner jet velocity ratios greater than one, found that coherent structures in the outer shear layer dominate those in the inner shear layer
 - At large axial distances, shear-layer vortices exhibit helical structures

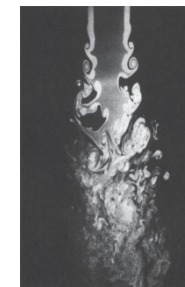

Dahm *et al.*, *JFM* 1992

Baseline POM & CPSD: SAR-thick – $P_r = 0.44$

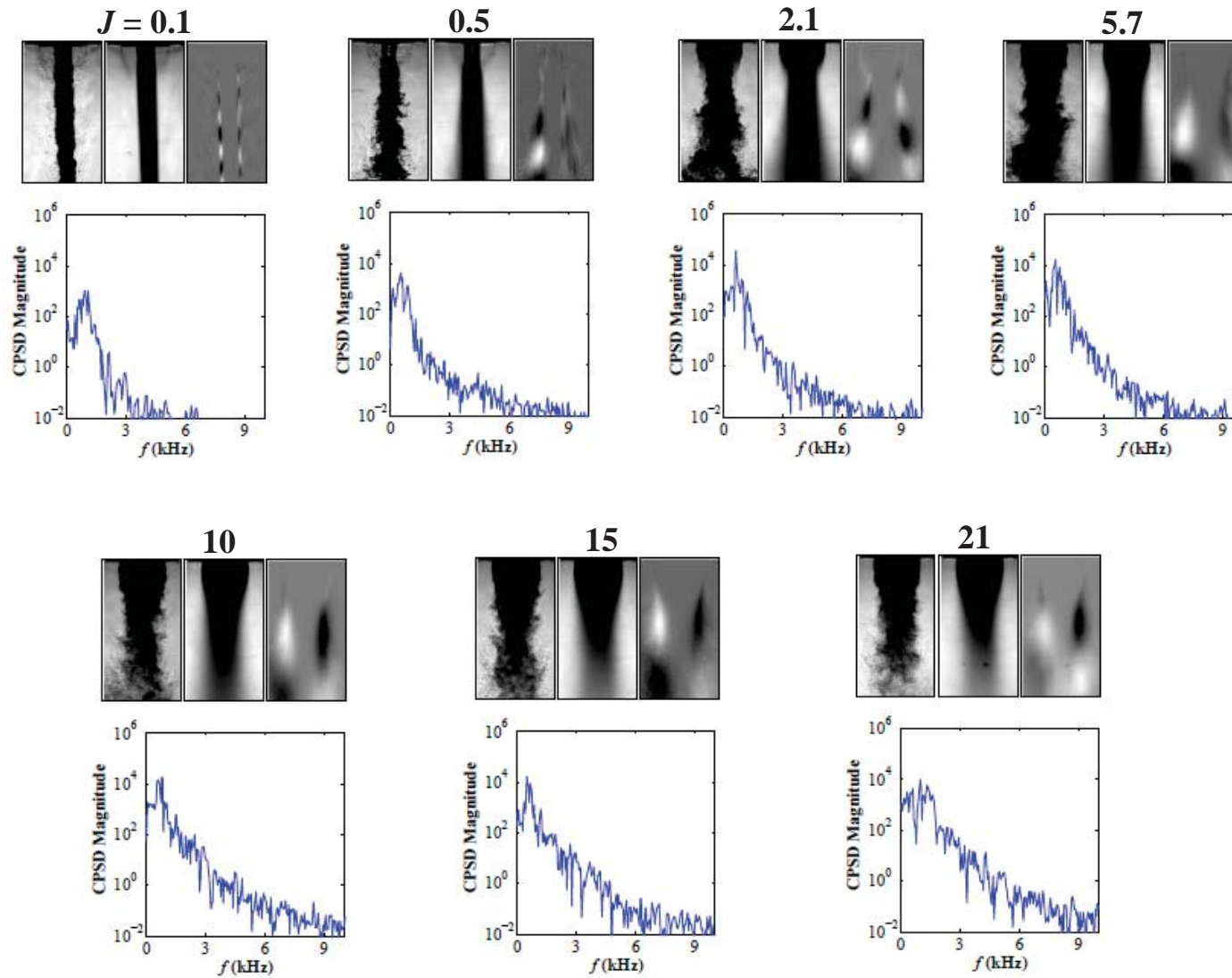

Baseline POM & CPSD: SAR-thick – $P_r = 1.05$

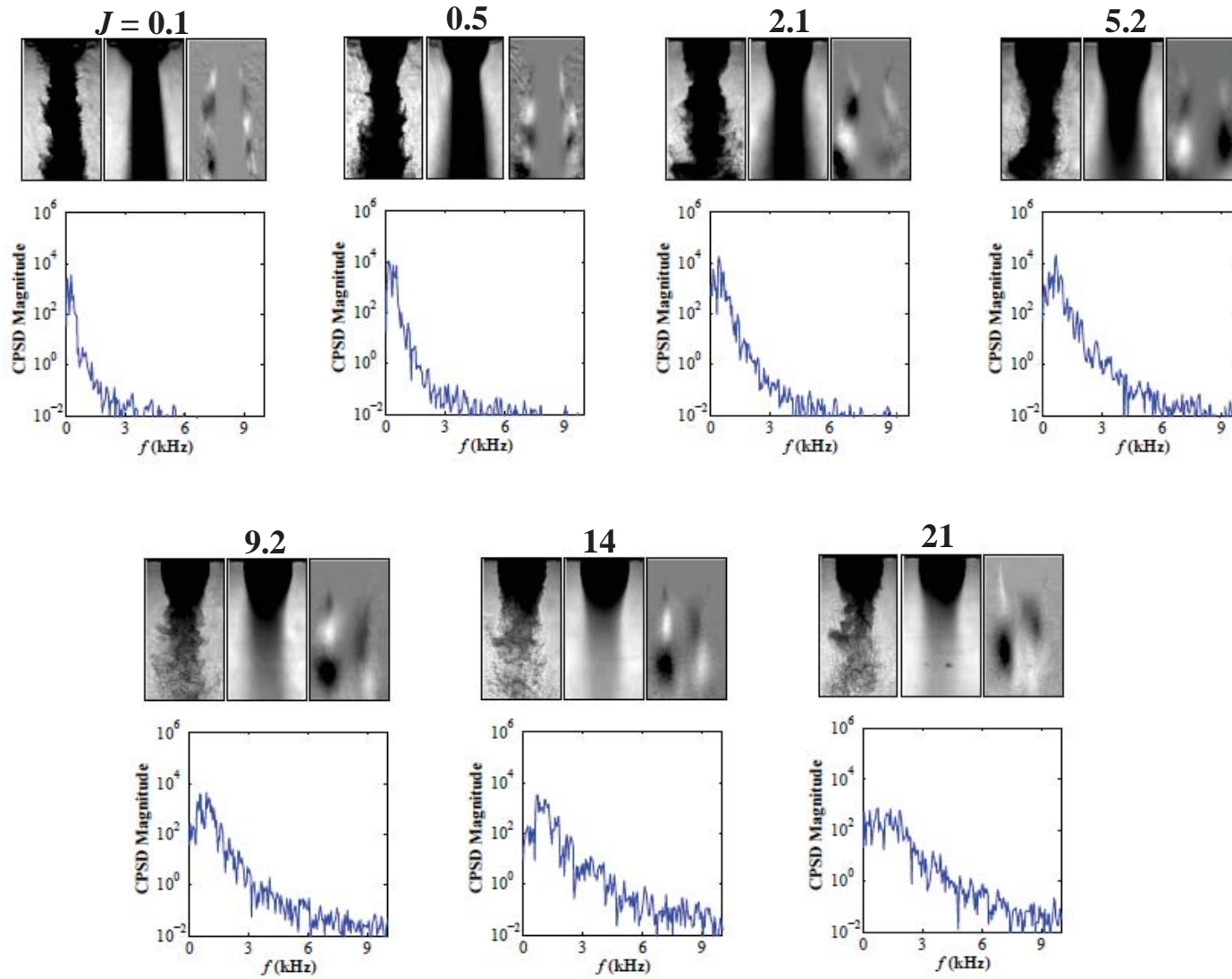

Inner Shear-Layer Structure Velocity – Pr = 0.44

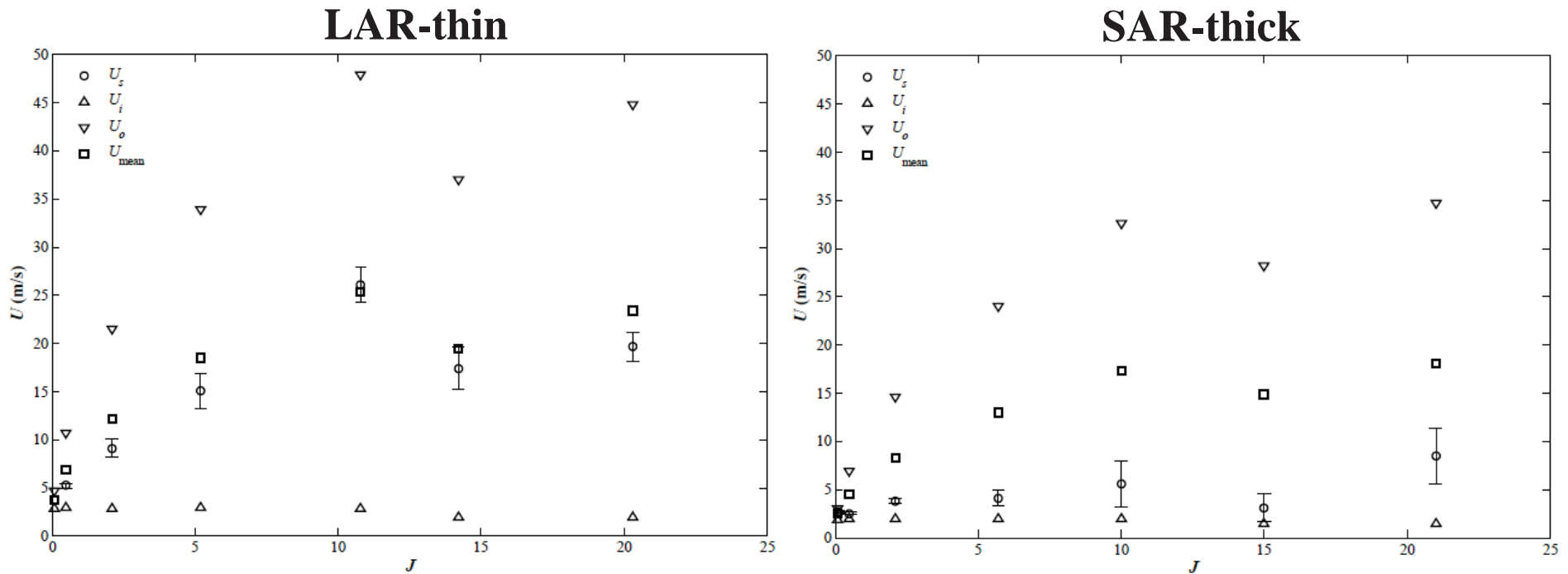

Inner Shear-Layer Structure Velocity – Pr = 1.05

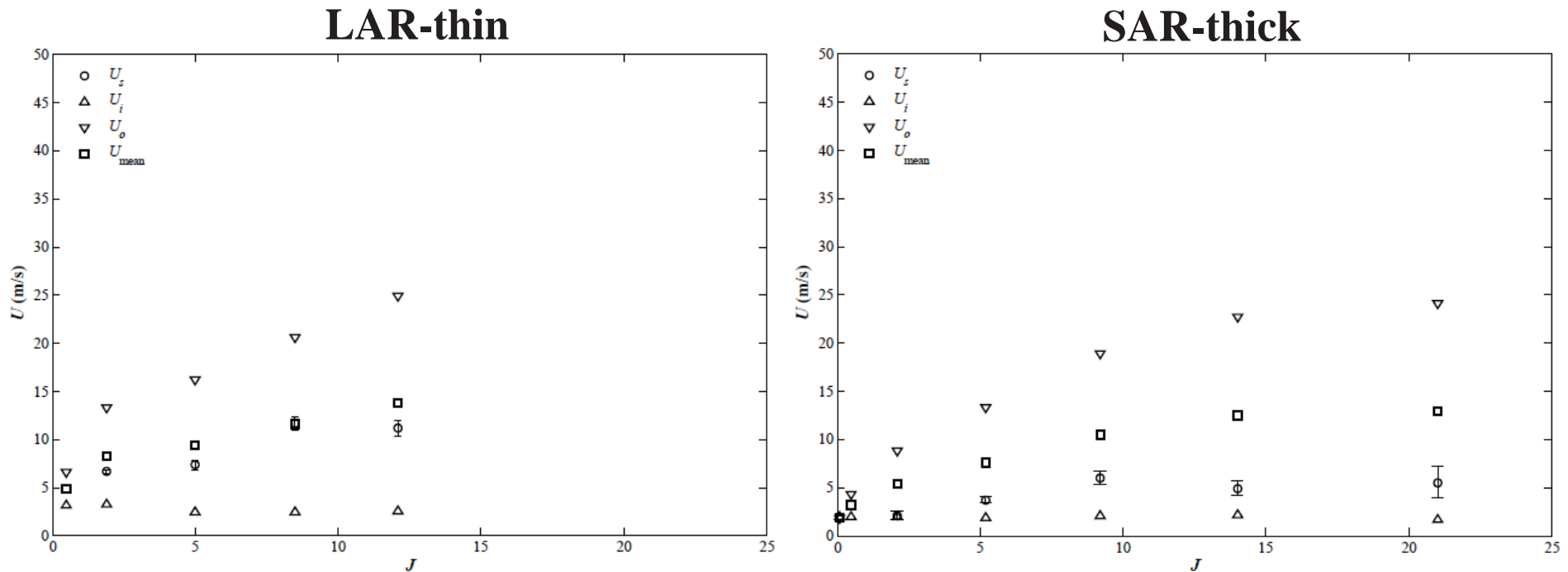

Forced POM & CPSD: LAR-thin – $P_r = 0.44$

$J = 0.1$

$J = 0.5$

PAN

PN

PAN

PN

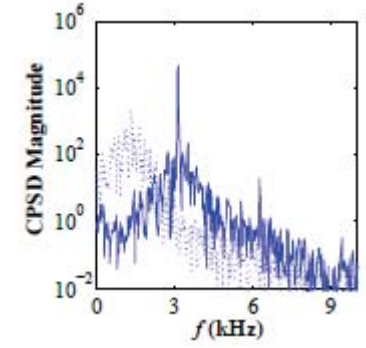
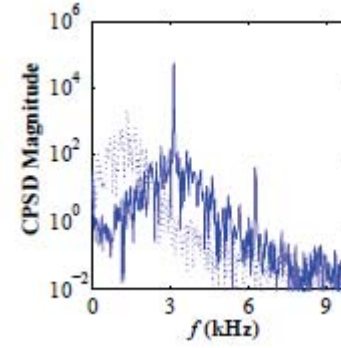
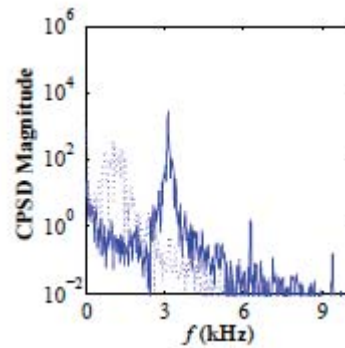
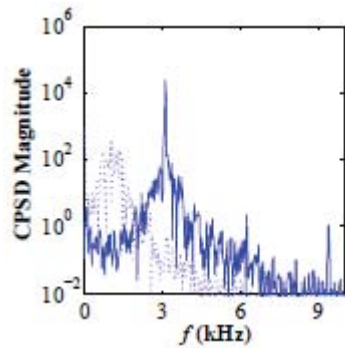
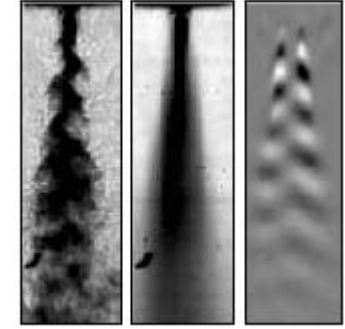
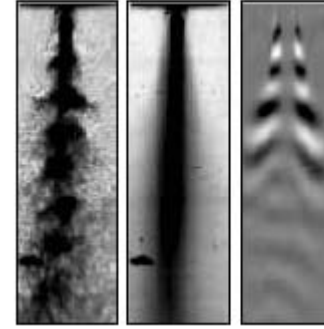
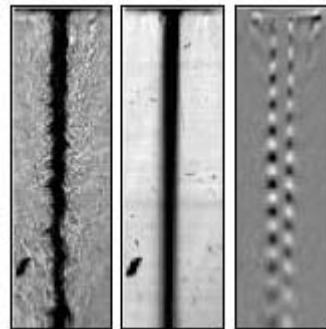
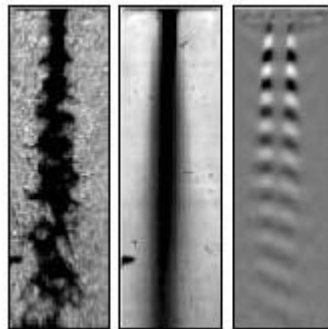

Forced POM & CPSD: LAR-thin – $P_r = 0.44$

$J = 2.1$

$J = 5.2$

PAN

PN

PAN

PN

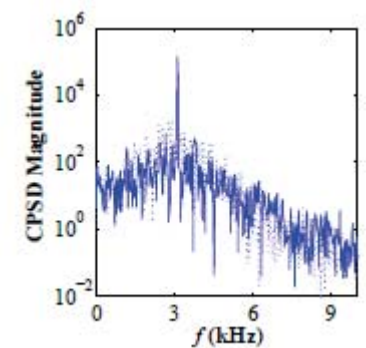
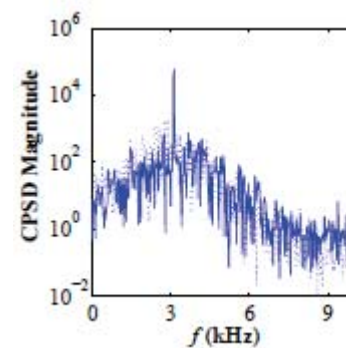
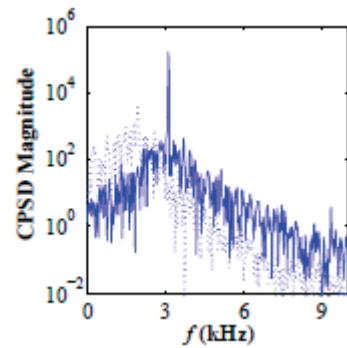
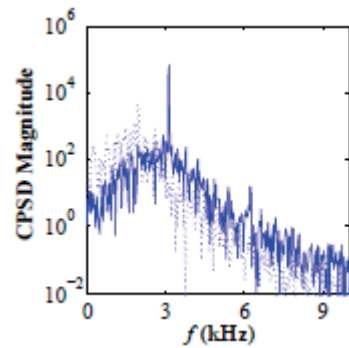
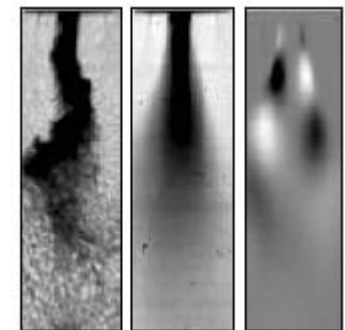
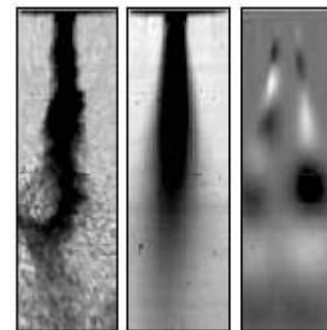
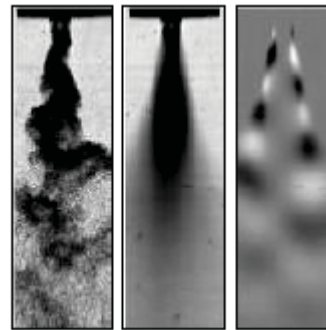
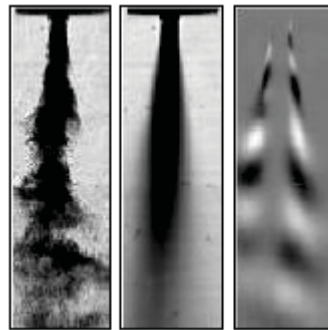

Forced POM & CPSD: LAR-thin – $P_r = 0.44$

$J = 11$

$J = 20$

PAN

PN

PAN

PN

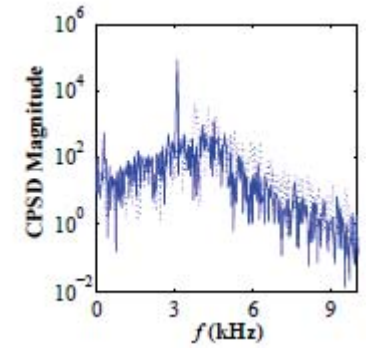
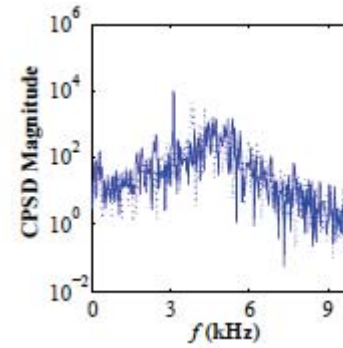
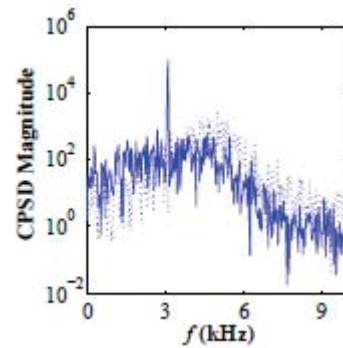
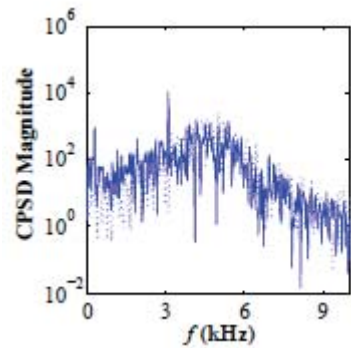
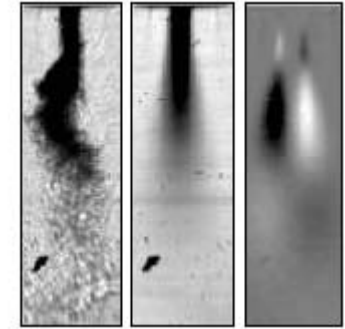
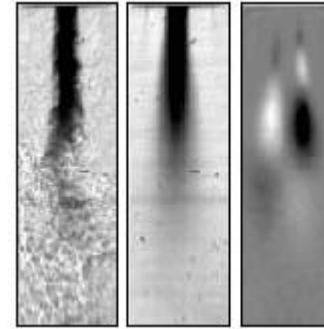
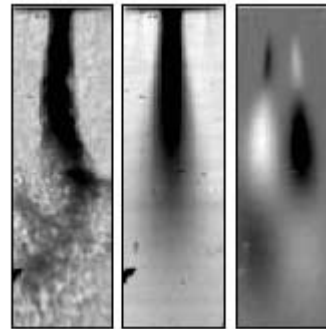
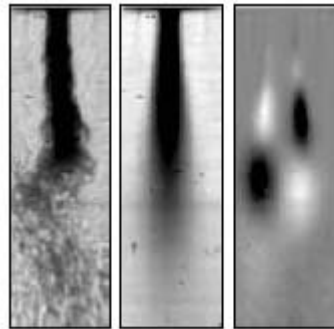

Forced POM & CPSD: LAR-thin – $P_r = 1.05$

$J = 0.5$

$J = 5.0$

PAN

PN

PAN

PN

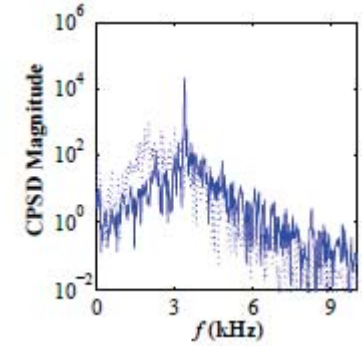
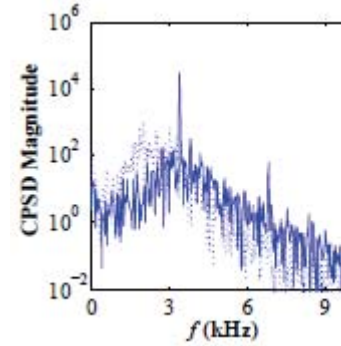
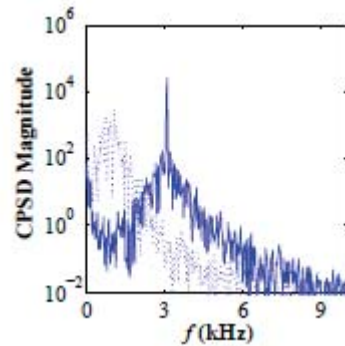
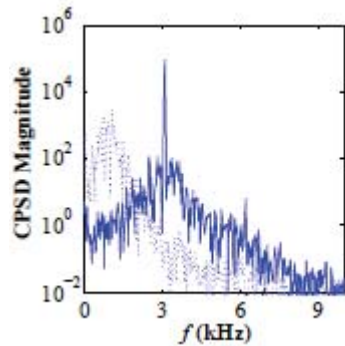
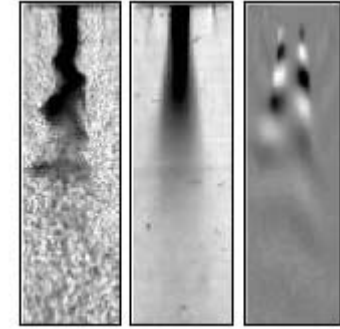
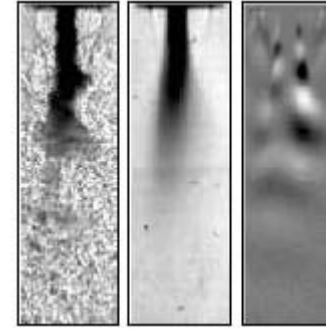
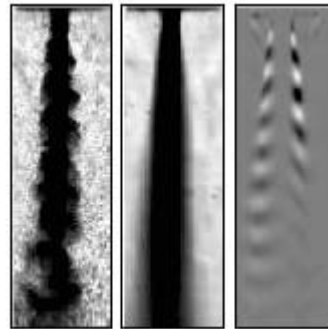
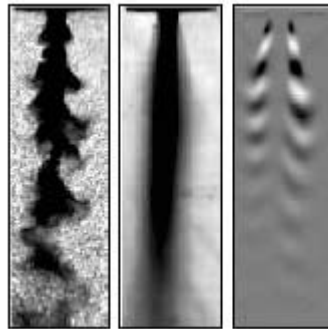

Forced POM & CPSD: LAR-thin – $P_r = 1.05$

$J = 1.9$

PAN

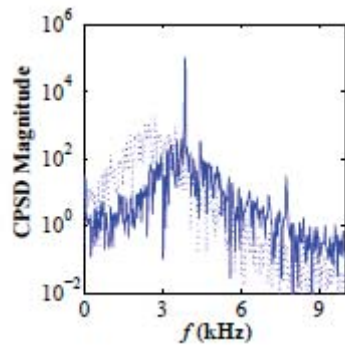
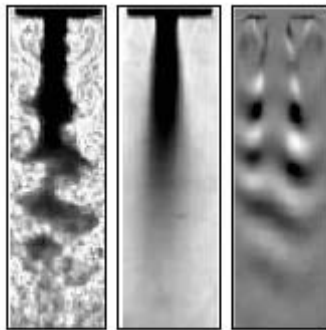

$J = 8.5$

PAN

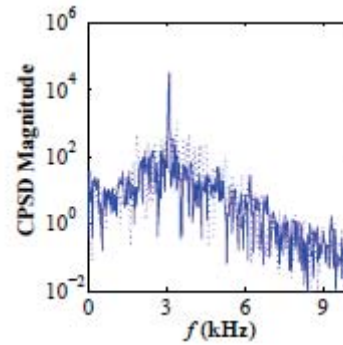
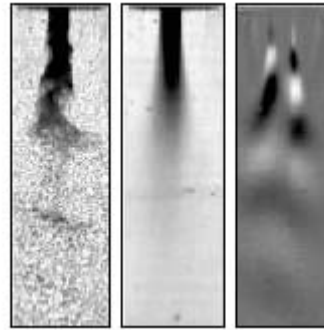

$J = 12$

PAN

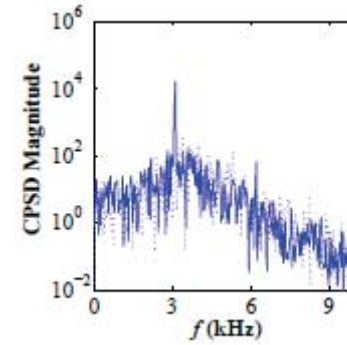
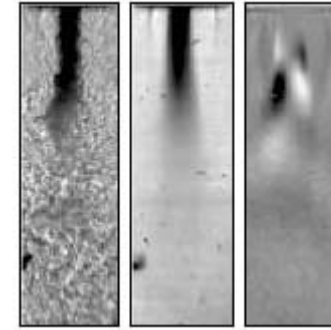

Forced POM & CPSD: SAR-thick – $P_r = 0.44$

$J = 0.1$

PAN

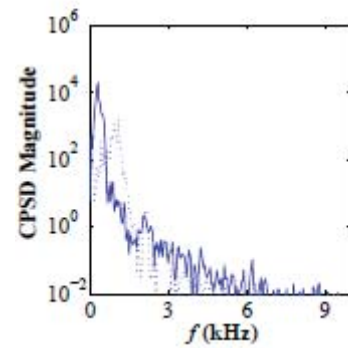
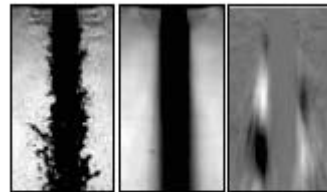

$J = 0.5$

PAN

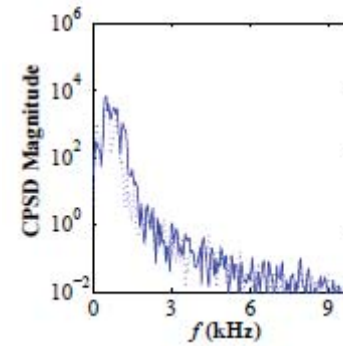
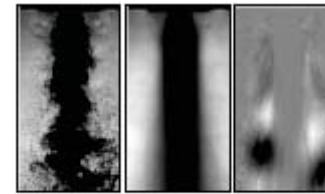

Forced POM & CPSD: SAR-thick – $P_r = 0.44$

$J = 2.1$

$J = 5.7$

PAN

PN

PAN

PN

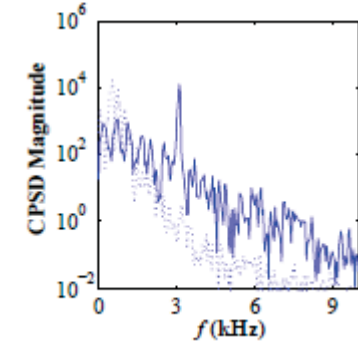
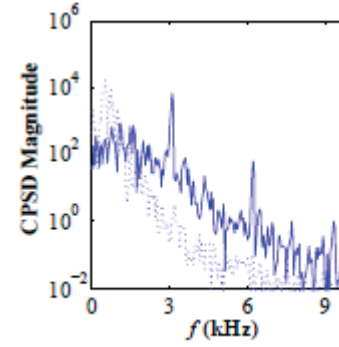
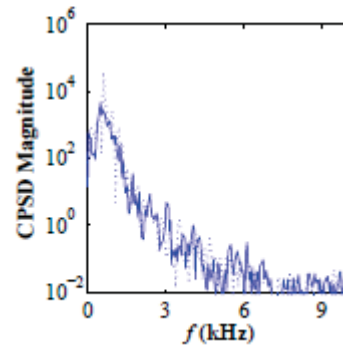
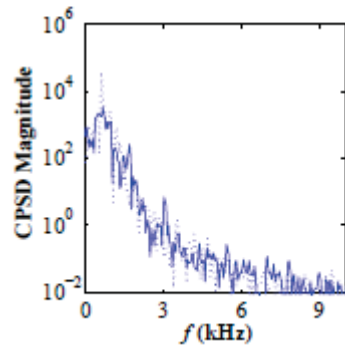
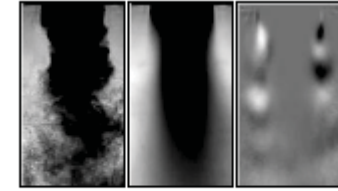
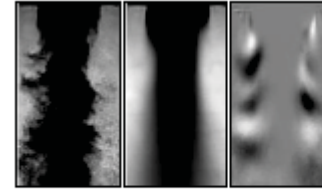
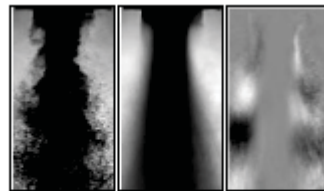
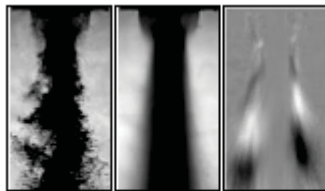

Forced POM & CPSD: SAR-thick – $P_r = 0.44$

$J = 10$

$J = 21$

PAN

PN

PAN

PN

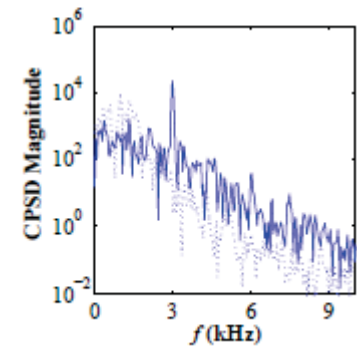
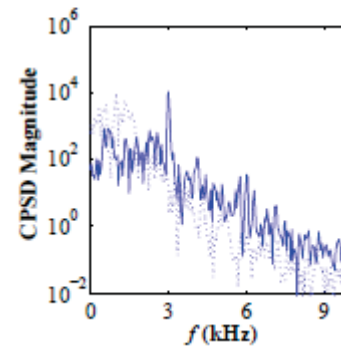
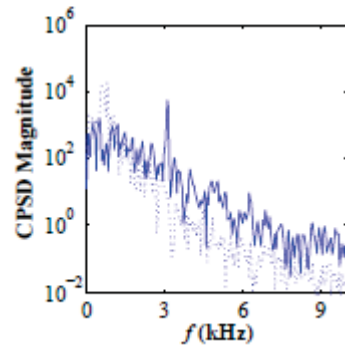
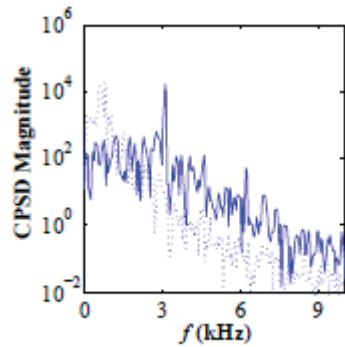
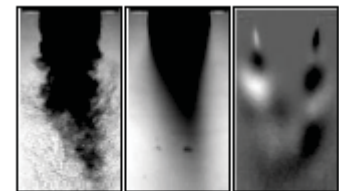
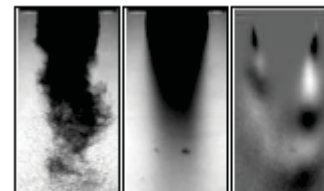
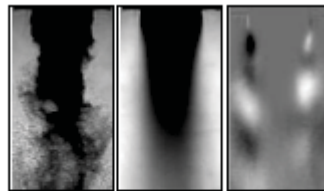
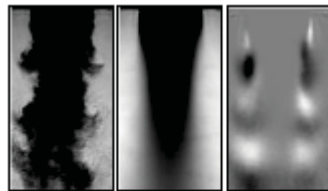

Forced POM & CPSD: SAR-thick – $P_r = 1.05$

$J = 0.5$

PAN

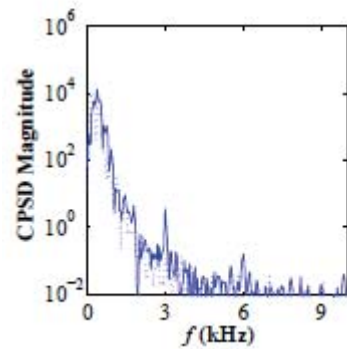
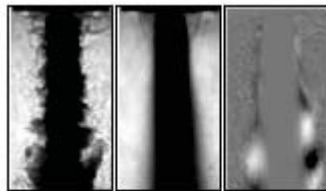

PN

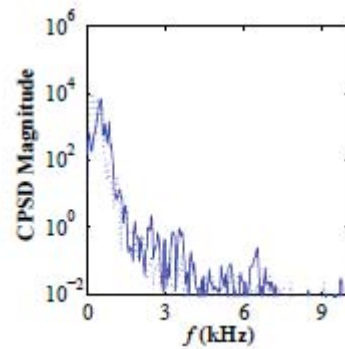
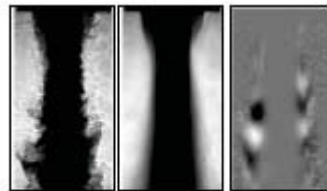

$J = 2.1$

PAN

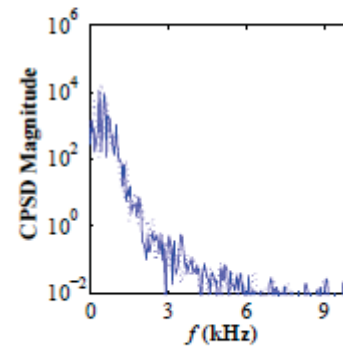
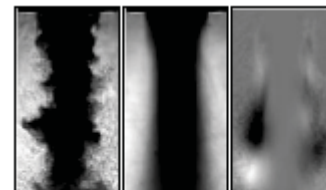

(a) $J = 2.1$, PAN

PN

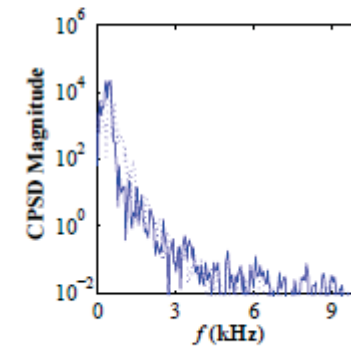
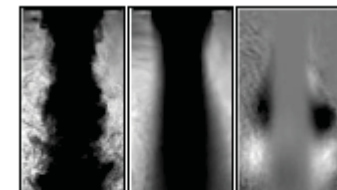

(b) $J = 2.1$, PN

Forced POM & CPSD: SAR-thick – $P_r = 1.05$

$J = 5.2$

$J = 9.2$

PAN

PN

PAN

PN

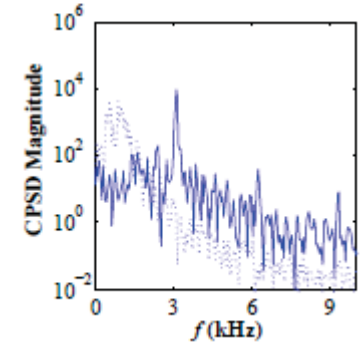
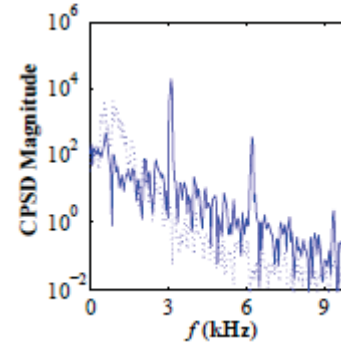
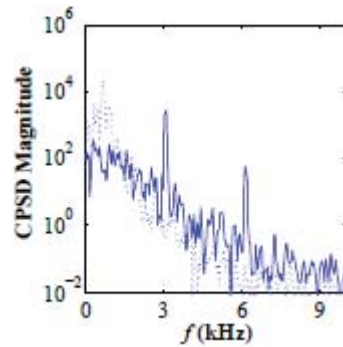
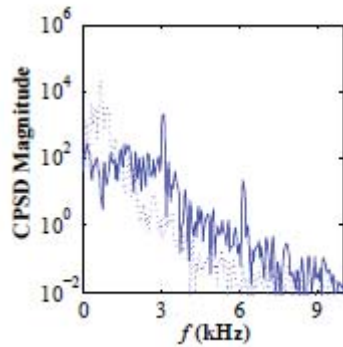
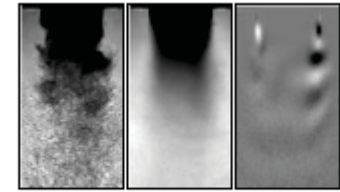
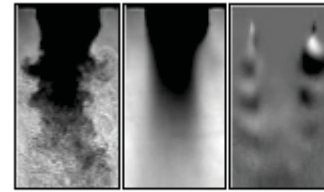
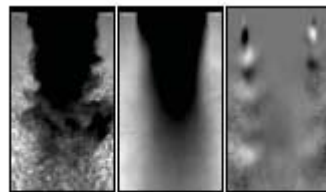
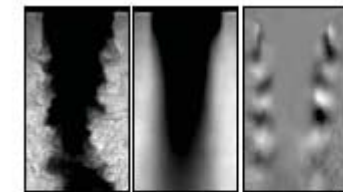

Forced POM & CPSD: SAR-thick – $P_r = 1.05$

$J = 14$

$J = 21$

PAN

PN

PAN

PN

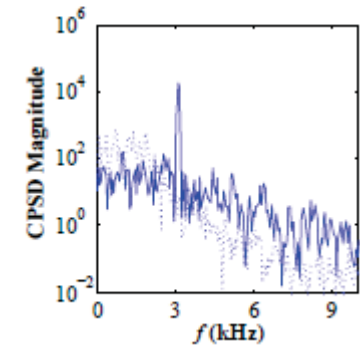
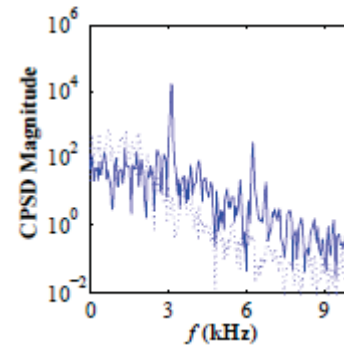
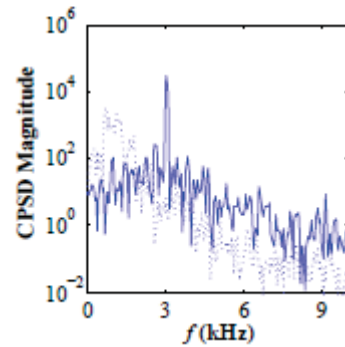
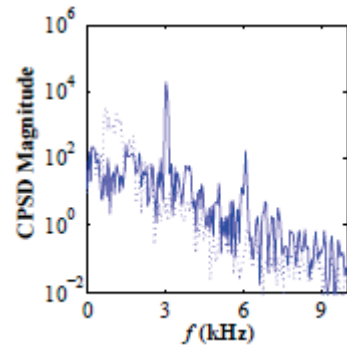
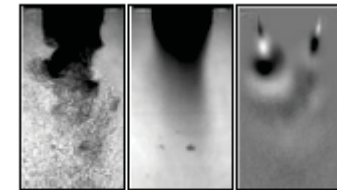
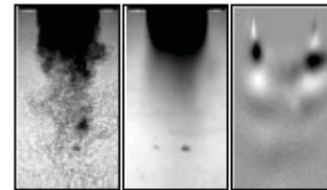
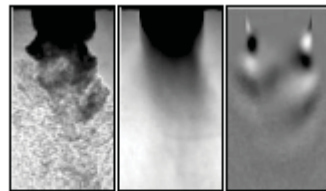
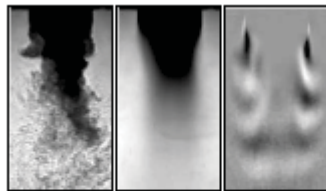

Conclusions

- Baseline flow normalized dark-core lengths, L_B/D_1 :
 - Power-law curve-fit of L_B/D_1 variation with J showed that $P_r = 1.05$ cases had a stronger dependence ($J^{-0.50}$ for the LAR-thin and $J^{0.54}$ for the SAR-thick); $P_r = 0.44$ cases varied as $J^{-0.39}$ for the LAR-thin and $J^{-0.35}$ for the SAR-thick.
 - For a given J and same P_r , SAR-thick flows had smaller L_B/D_1 than LAR-thin flows
 - Considering the LAR-thick and SAR-thin injector flow data at both P_r , it can be deduced that L_B/D_1 increased with A_o/A_i while it decreased with J and t/D_1
 - ⇒ injector geometry also plays an important role in addition to J

- Acoustically forced flow normalized dark-core lengths, L_{PAN}/L_B or L_{PN}/L_B :
 - LAR-thin injector
 - Both L_{PAN}/L_B and L_{PN}/L_B less than one and approached one with increasing J
 - ⇒ The flow became less sensitive to forcing with increasing J .
 - SAR-thick injector
 - For low J (< 10) flows, L_{PAN}/L_B stayed around one
 - L_{PN}/L_B approached one with increasing J
 - ⇒ Flow in recirculation zone only effective in dampening the effect of PAN forcing at lower J



Conclusions (cont'd)

- Dynamic characteristics of baseline flows:
 - LAR-thin injector:
 - inner shear layer formed immediately downstream of the exit
 - baseline flow inner shear layer characterized by antisymmetric flow structures that indicated the presence of helical instabilities
 - peak frequencies of the magnitude spectra became broader and shifted to higher frequencies with increasing J
 - SAR-thick injector:
 - region immediately downstream of the thick inner jet post formed a flow recirculation zone delaying formation of shear layer between the bulk inner and outer jets
 - peak frequencies stayed at low frequencies despite increasing J



Conclusions (cont'd)

- Dynamic characteristics of forced flows:
 - LAR-thin injector:
 - PAN forcing produced symmetric flow structures in the inner shear layer region for low $J (< 5)$ flows at both P_r
 - Magnitude spectra showed dominant peaks identical to the forcing frequency
 - Higher $J (> 5)$ flows under PAN forcing produced antisymmetric structures that resembled that of baseline
 - Magnitude spectra retained baseline flow spectral characteristics
 - peak frequencies of the magnitude spectra became broader and shifted to higher frequencies with increasing J
 - PN forcing produced sinusoid disturbance
 - SAR-thick injector:
 - PAN forcing produced no appreciable response in the inner shear layer of the low $J (< 5)$ flows, at both P_r
 - Spectra showed low frequency peaks, and no peaks at forcing frequencies were detected
 - at higher $J (> 5)$ and both P_r , PAN forcing produced symmetric structures below the recirculation zone with peaks in the spectra at the forcing frequencies
 - PN forcing also produced appreciable response at higher J



Acknowledgement

- Technicians
 - Randy Harvey, David Hill, Earl Thomas (ERC)
 - Todd Newkirk (Jacobs Engineering)
- SAR Data
 - Dr. Juan Rodriguez
- This work is sponsored by the Air Force Office of Scientific Research under Dr. Mitat Birkan, program manager.



Back-Up Slides



Distribution A: Approved for Public Release; Distribution Unlimited



Acoustic Field Set-Up: Pressure Node

- Pressure node (PN) – condition of minimum pressure perturbation in the acoustic field
- Piezo-sirens forced out-of-phase
- Superposition of quasi-1D acoustic waves traveling in opposite directions \Rightarrow PN at the jet location (geometric center of test section)

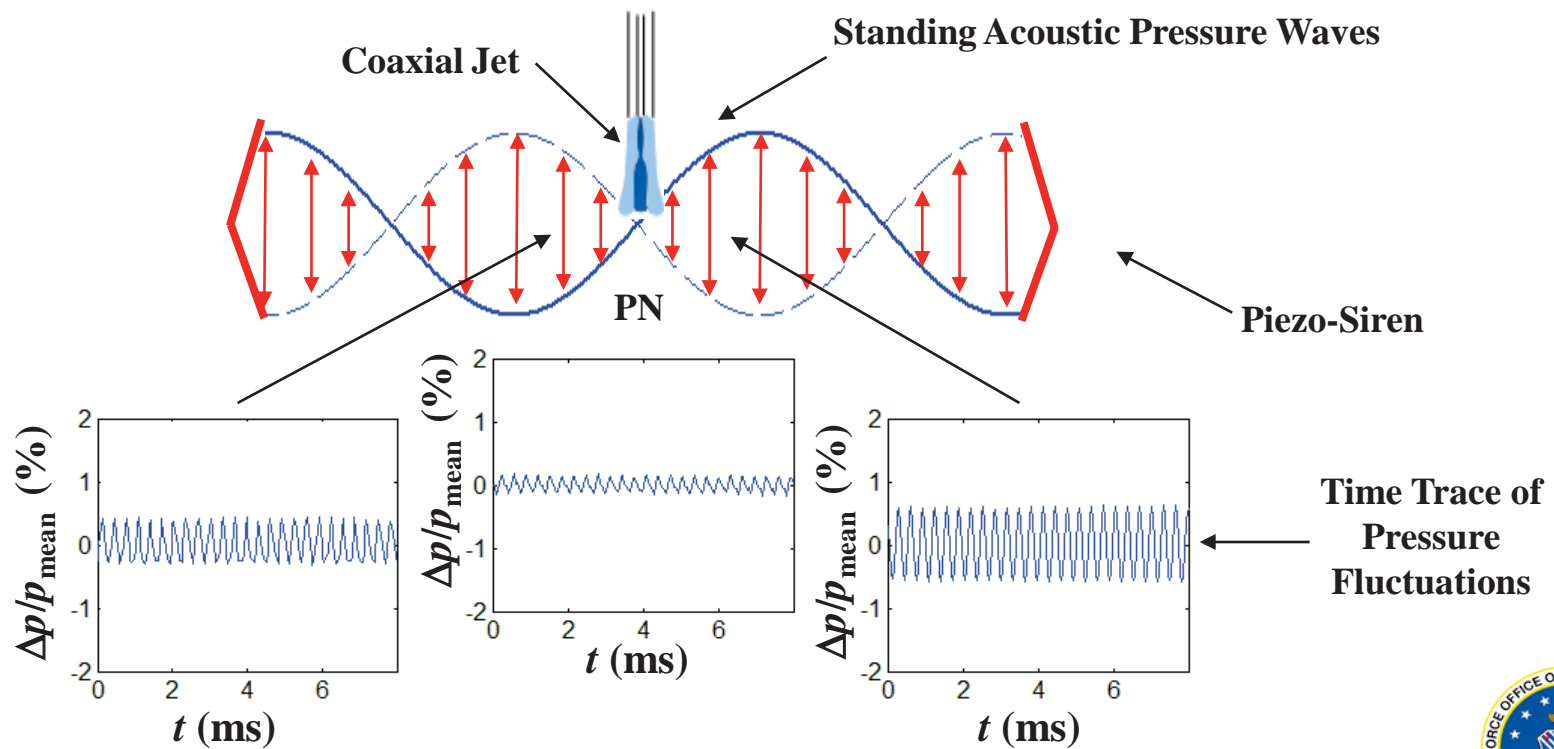

Baseline Normalized DCL, L_B/D_1 – LAR-thin

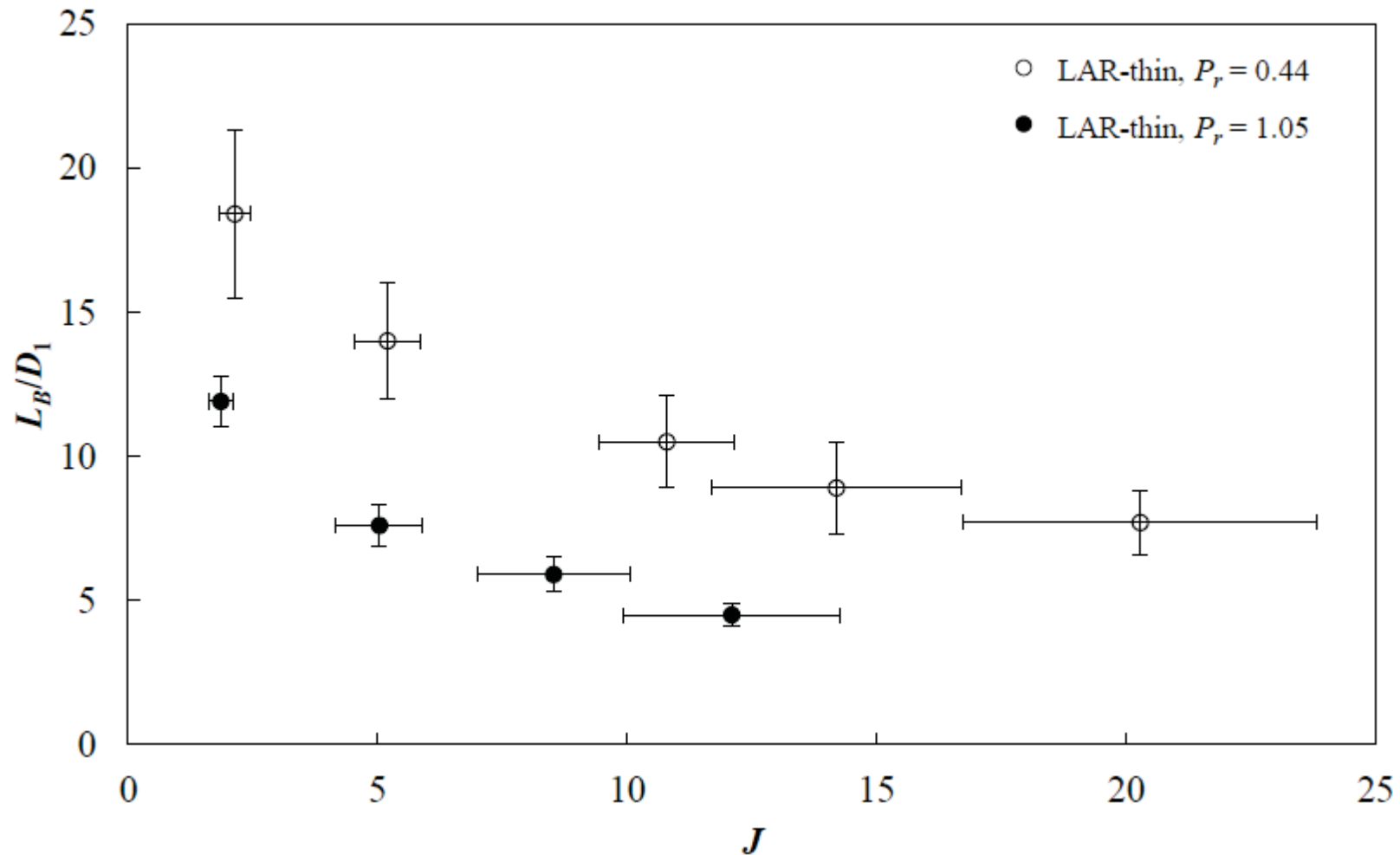

Baseline Normalized DCL, L_B/D_1 – SAR-thick

